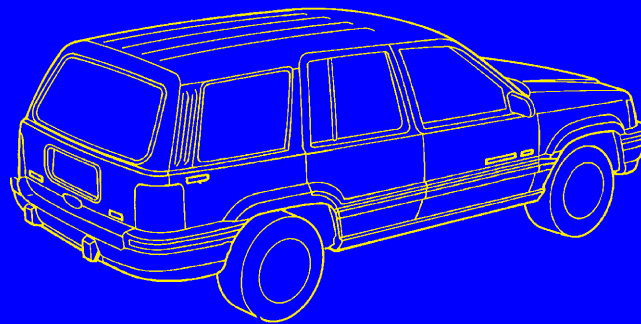


***Welcome to the
1998 Jeep Grand Cherokee
(RHD & LHD)
Interactive Electronic Service
Manual!***

CLICK ON VEHICLE TO BEGIN



CHRYSLER CORPORATION

SERVICE MANUAL SUPPLEMENT

1998 GRAND CHEROKEE

To order the special service tools used and illustrated, please refer to the instructions on inside back cover.



NO PART OF THIS PUBLICATION MAY BE REPRODUCED, STORED IN A RETRIEVAL SYSTEM, OR TRANSMITTED, IN ANY FORM OR BY ANY MEANS, ELECTRONIC, MECHANICAL, PHOTOCOPYING, RECORDING, OR OTHERWISE, WITHOUT THE PRIOR WRITTEN PERMISSION OF CHRYSLER CORPORATION.

Chrysler Corporation reserves the right to make changes in design or to make additions to or improvements in its products without imposing any obligations upon itself to install them on its products previously manufactured.



Paper Content
50% Recycled

FOREWORD

The information contained in this service manual has been prepared for the professional automotive technician involved in daily repair operations. This manual does not cover theory of operation, which is addressed in service training material. Information describing the operation and use of standard and optional equipment is included in the Owner's Manual provided with the vehicle.

Information in this manual is divided into groups. These groups contain general information, diagnosis, testing, adjustments, removal, installation, disassembly, and assembly procedures for the systems and components. To assist in locating a group title page, use the Group Tab Locator on the following page. The solid bar after the group title is aligned to a solid tab on the first page of each group. The first page of the group has a contents section that lists major topics within the group. If you are not sure which Group contains the information you need, look up the Component/System in the alphabetical index located in the rear of this manual.

Tightening torques are provided as a specific value throughout this manual. This value represents the midpoint of the acceptable engineering torque range for a given fastener application. These torque values are intended for use in service assembly and installation procedures using the correct OEM fasteners. When replacing fasteners, always use the same type (part number) fastener as removed.

Chrysler Corporation reserves the right to change testing procedures, specifications, diagnosis, repair methods, or vehicle wiring at any time without prior notice or incurring obligation.

GROUP TAB LOCATOR

	Introduction
0	Lubrication and Maintenance
2	Suspension
7	Cooling System
8B	Starting Systems
8C	Charging System
8E	Instrument Panel Systems
8H	Vehicle Speed Control System
8L	Lamps
8Q	Vehicle Theft/Security Systems
8W	Wiring Diagrams
9	Engine
11	Exhaust System and Intake Manifold
14	Fuel System – 2.5L Diesel Engine
19	Steering
21	Transmission and Transfer Case
25	Emission Control System

GROUP TAB LOCATOR

IN	Introduction
INa	Introduction
0	Lubrication and Maintenance
0a	Lubrication and Maintenance
2	Suspension
2a	Suspension
3	Differential and Driveline
5	Brakes
7	Cooling System
7a	Cooling System
8A	Battery
8B	Starting Systems
8Ba	Starting Systems
8C	Charging System
8Ca	Charging System
8D	Ignition System
8E	Instrument Panel Systems
8Ea	Instrument Panel Systems
8F	Audio Systems
8G	Horn Systems
8H	Vehicle Speed Control System
8Ha	Vehicle Speed Control System
8J	Turn Signal and Hazard Warning Systems
8K	Wipers and Washer Systems
8L	Lamps
8La	Lamps
8M	Passive Restraint Systems

8N	Electrically Heated Systems
8P	Power Lock Systems
8Q	Vehicle Theft/Security Systems
8Qa	Vehicle Theft/Security Systems
8R	Power Seat Systems
8S	Power Window Systems
8T	Power Mirror Systems
8U	Chime/Buzzer Warning Systems
8V	Overhead Console Systems
8W	Wiring Diagrams
9	Engine
9a	Engine
11	Exhaust System and Intake Manifold
11a	Exhaust System and Intake Manifold
13	Frame and Bumpers
14	Fuel System
14a	Fuel System - 2.5L Diesel Engine
19	Steering
19a	Steering
21	Transmission and Transfer Case
21a	Transmission and Transfer Case
22	Tires and Wheels
23	Body
24	Heating and Air Conditioning
24a	Heating and Air Conditioning
25	Emission Control Systems
25a	Emission Control System

INTRODUCTION

CONTENTS

	page		page
GENERAL INFORMATION		METRIC SYSTEM	6
BODY CODE PLATE	2	THREADED HOLE REPAIR	6
FASTENER IDENTIFICATION	3	TORQUE REFERENCES	8
FASTENER USAGE	6	VEHICLE DIMENSIONS	2
INTERNATIONAL VEHICLE CONTROL AND DISPLAY SYMBOLS	2	VEHICLE IDENTIFICATION NUMBER (VIN)	1
		VEHICLE SAFETY CERTIFICATION LABEL	1

GENERAL INFORMATION

VEHICLE IDENTIFICATION NUMBER (VIN)

The Vehicle Identification Number (VIN) plate is attached to the top left side of the instrument panel. The VIN contains 17 characters that provide data concerning the vehicle. Refer to the decoding chart to determine the identification of a vehicle. The Vehicle Identification Number is also imprinted on the:

- Body Code Plate.
- Equipment Identification Plate.
- Vehicle Safety Certification Label.
- Frame rail.

VEHICLE SAFETY CERTIFICATION LABEL

A vehicle safety certification label (Fig. 1) is attached to every Chrysler Corporation vehicle. The label certifies that the vehicle conforms to all applicable Federal Motor Vehicle Safety Standards. The label also lists:

- Month and year of vehicle manufacture.
- Gross Vehicle Weight Rating (GVWR). The gross front and rear axle weight ratings (GAWR's) are based on a minimum rim size and maximum cold tire inflation pressure.
- Vehicle Identification Number (VIN).
- Type of vehicle.
- Type of rear wheels.
- Bar code.
- Month, Day and Hour (MDH) of final assembly.

VEHICLE IDENTIFICATION NUMBER DECODING CHART

POSITION	INTERPRETATION	CODE = DESCRIPTION
1	Country of Origin	1 = United States
2	Make	J = Jeep
3	Vehicle Type	4 = MPV
4	Gross Vehicle Weight Rating	G = 5001-6000 lbs.
5	Vehicle Line	X = Grand Cherokee 4X2 (LHD) Z = Grand Cherokee 4X4 (LHD)
6	Series	5 = Laredo 7 = Limited 8 = Limited (W/5.9L)
7	Body Style	8 = 4dr Sport Utility
8	Engine	S = 4.0 Liter Y = 5.2 Liter Z = 5.9 Liter
9	Check Digit	
10	Model Year	W = 1998
11	Assembly Plant	C = Jefferson Assembly
12 thru 17	Vehicle Build Sequence	

GENERAL INFORMATION (Continued)

- Paint and Trim codes.
- Country of origin.

The label is located on the driver-side door shut-face.

VEHICLE DIMENSIONS

The vehicle exterior and interior dimensions are listed in inches and centimeters.

EXTERIOR DIMENSIONS

Wheel Base	105.9 in. (269.1 cm.)
Track: Front58.0 in. (147.3 cm.)
Track: Rear58.0 in. (147.3 cm.)
Length176.7 in. (448.8 cm.)
Width69.3 in. (176.0 cm.)
Height64.7 in. (164.3 cm.)

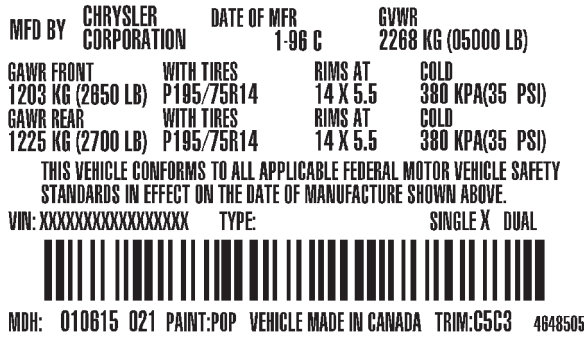
INTERIOR DIMENSIONS

Head Room-Front38.9 in. (98.8 cm.)
Head Room-Rear39.0 in. (99.0 cm.)
Leg-Front40.9 in. (103.8 cm.)
Leg-Rear35.7 in. (90.6 cm.)
Shoulder-Front58.3 in. (148.0 cm.)
Shoulder-Rear57.6 in. (146.3 cm.)
Hip-Front57.8 in. (146.8 cm.)
Hip-Rear49.3 in. (125.2 cm.)

INTERNATIONAL VEHICLE CONTROL AND DISPLAY SYMBOLS

INTERNATIONAL VEHICLE CONTROL AND DISPLAY SYMBOLS

The graphic symbols illustrated in the following chart are used to identify various instrument controls. The symbols correspond to the controls and displays that are located on the instrument panel.

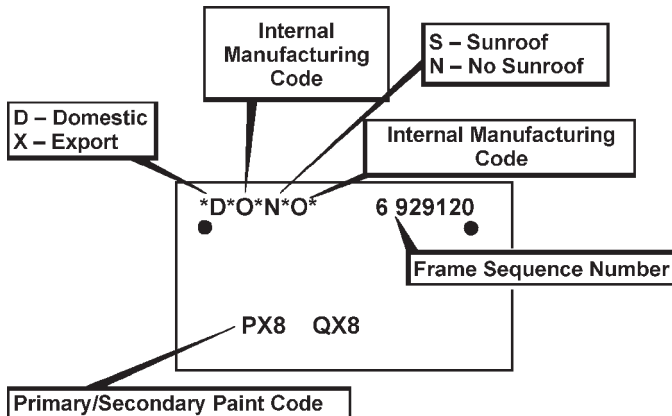


80ab36d9

Fig. 1 Vehicle Safety Certification Label—Typical

BODY CODE PLATE

A metal Body Code plate is attached to the top, left side of the radiator reinforcement. The information listed on the plate (Fig. 2) is used for manufacturing and service purposes.



























80a5f17a

Fig. 2 Body Code Plate

GENERAL INFORMATION (Continued)

INTERNATIONAL CONTROL AND DISPLAY SYMBOLS

 HIGH BEAM	 FOG LIGHTS	 HEADLIGHTS, PARKING LIGHTS, PANEL LIGHTS	 TURN SIGNAL	 HAZARD WARNING	 WINDSHIELD WASHER
 WINDSHIELD WIPER	 WINDSHIELD WIPER AND WASHER	 WINDSCREEN DEMISTING AND DEFROSTING	 VENTILATING FAN	 REAR WINDOW DEFOGGER	 REAR WINDOW WIPER
 REAR WINDOW WASHER	 FUEL	 ENGINE COOLANT TEMPERATURE	 BATTERY CHARGING CONDITION	 ENGINE OIL	 SEAT BELT
 BRAKE FAILURE	 PARKING BRAKE	 FRONT HOOD	 REAR HOOD (TRUNK)	 HORN	 LIGHTER

80a53b2d

FASTENER IDENTIFICATION

FASTENER IDENTIFICATION

THREAD IDENTIFICATION

SAE and metric bolt/nut threads are not the same. The difference is described in the Thread Notation chart (Fig. 3).

INCH		METRIC	
5/16-18		M8 X 1.25	
THREAD MAJOR DIAMETER IN INCHES	NUMBER OF THREADS PER INCH	THREAD MAJOR DIAMETER IN MILLIMETERS	DISTANCE BETWEEN THREADS IN MILLIMETERS

PR606B

Fig. 3 Thread Notation—SAE and Metric

GRADE/CLASS IDENTIFICATION

The SAE bolt strength grades range from grade 2 to grade 8. The higher the grade number, the greater the bolt strength. Identification is determined by the line marks on the top of each bolt head. The actual bolt strength grade corresponds to the number of line marks plus 2. The most commonly used metric bolt strength classes are 9.8 and 12.9. The metric strength class identification number is imprinted on the head of the bolt. The higher the class number, the greater the bolt strength. Some metric nuts are imprinted with a single-digit strength class on the nut face. Refer to the Fastener Identification and Fastener Strength Charts.

GENERAL INFORMATION (Continued)

FASTENER IDENTIFICATION

Bolt Markings and Torque - Metric

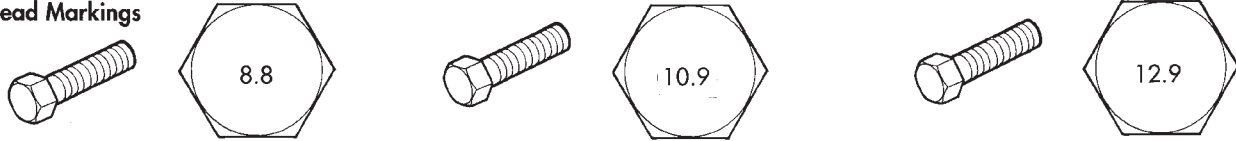
Commercial Steel Class

8.8

10.9

12.9

Bolt Head Markings



Body Size	Torque				Torque				Torque			
	Cast Iron		Aluminum		Cast Iron		Aluminum		Cast Iron		Aluminum	
	Diam.	N•m	ft-lb	N•m	ft-lb	N•m	ft-lb	N•m	ft-lb	N•m	ft-lb	N•m
6	9	5	7	4	14	9	11	7	14	9	11	7
7	14	9	11	7	18	14	14	11	23	18	18	14
8	25	18	18	14	32	23	25	18	36	27	28	21
10	40	30	30	25	60	45	45	35	70	50	55	40
12	70	55	55	40	105	75	80	60	125	95	100	75
14	115	85	90	65	160	120	125	95	195	145	150	110
16	180	130	140	100	240	175	190	135	290	210	220	165
18	230	170	180	135	320	240	250	185	400	290	310	230

Bolt Markings and Torque Values - U.S. Customary

SAE Grade Number

5

8

Bolt Head Markings

These are all SAE Grade 5 (3) line



Bolt Torque - Grade 5 Bolt


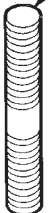


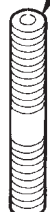


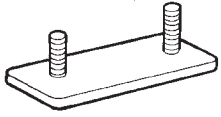


Bolt Torque - Grade 8 Bolt

Body Size	Cast Iron		Aluminum		Cast Iron		Aluminum	
	N•m	ft-lb	N•m	ft-lb	N•m	ft-lb	N•m	ft-lb
1/4 - 20	9	7	8	6	15	11	12	9
- 28	12	9	9	7	18	13	14	10
5/16 - 18	20	15	16	12	30	22	24	18
- 24	23	17	19	14	33	24	25	19
3/8 - 16	40	30	25	20	55	40	40	30
- 24	40	30	35	25	60	45	45	35
7/16 - 14	60	45	45	35	90	65	65	50
- 20	65	50	55	40	95	70	75	55
1/2 - 13	95	70	75	55	130	95	100	75
- 20	100	75	80	60	150	110	120	90
9/16 - 12	135	100	110	80	190	140	150	110
- 18	150	110	115	85	210	155	170	125
5/8 - 11	180	135	150	110	255	190	205	150
- 18	210	155	160	120	290	215	230	170
3/4 - 10	325	240	255	190	460	340	365	270
- 16	365	270	285	210	515	380	410	300
7/8 - 9	490	360	380	280	745	550	600	440
- 14	530	390	420	310	825	610	660	490
1 - 8	720	530	570	420	1100	820	890	660
- 14	800	590	650	480	1200	890	960	710

GENERAL INFORMATION (Continued)

FASTENER STRENGTH

HOW TO DETERMINE BOLT STRENGTH

	Mark	Class		Mark	Class
Hexagon head bolt	 <p>Bolt head No.</p> <p>4 — 4T 5 — 5T 6 — 6T 7 — 7T 8 — 8T 9 — 9T 10 — 10T 11 — 11T</p>		Stud bolt	 <p>No mark</p>	4T
	 <p>No mark</p>	4T			
Hexagon flange bolt w/washer hexagon bolt	 <p>No mark</p>	4T	Welded bolt	 <p>Grooved</p>	6T
Hexagon head bolt	 <p>Two protruding lines</p>	5T			
Hexagon flange bolt w/washer hexagon bolt	 <p>Two protruding lines</p>	6T		4T	
Hexagon head bolt	 <p>Three protruding lines</p>	7T			
Hexagon head bolt	 <p>Four protruding lines</p>	8T			

GENERAL INFORMATION (Continued)

FASTENER USAGE

WARNING: USE OF AN INCORRECT FASTENER MAY RESULT IN COMPONENT DAMAGE OR PERSONAL INJURY.

Figure art, specifications and torque references in this Service Manual are identified in metric and SAE format.

During any maintenance or repair procedures, it is important to salvage all fasteners (nuts, bolts, etc.) for reassembly. If the fastener is not salvageable, a fastener of equivalent specification must be used.

THREADED HOLE REPAIR

Most stripped threaded holes can be repaired using a Helicoil®. Follow the manufactures recommendations for application and repair procedures.

METRIC SYSTEM

WARNING: USE OF AN INCORRECT FASTENER MAY RESULT IN COMPONENT DAMAGE OR PERSONAL INJURY.

Figure art, specifications and torque references in this Service Manual are identified in metric and SAE format.

During any maintenance or repair procedures, it is important to salvage metric fasteners (nuts, bolts, etc.) for reassembly. If the fastener is not salvageable, a fastener of equivalent specification should be used.

The metric system is based on quantities of one, ten, one hundred, one thousand and one million (Fig. 4).

Mega	-	(M) Million	Deci	-	(D) Tenth
Kilo	-	(K) Thousand	Centi	-	(C) Hundreth
		Milli	-	(m) Thousandth	

J901N-2

Fig. 4 Metric Prefixes

The following chart will assist in converting metric units to equivalent English and SAE units, or vise versa.

Refer to the Metric Conversion chart to convert torque values listed in metric Newton- meters (N·m). Also, use the chart to convert between millimeters (mm) and inches (in.)

CONVERSION FORMULAS AND EQUIVALENT VALUES

Multiply	By	To Get	Multiply	By	To Get
in-lbs	x 0.11298	= Newton-Meters (N·m)	N·m	x 8.851	= in-lbs
ft-lbs	x 1.3558	= Newton-Meters (N·m)	N·m	x 0.7376	= ft-lbs
Inches Hg (60°F)	x 3.377	= Kilopascals (kPa)	kPa	x 0.2961	= Inches Hg
psi	x 6.895	= Kilopascals (kPa)	kPa	x 0.145	= psi
Inches	x 25.4	= Millimeters (mm)	mm	x 0.03937	= Inches
Feet	x 0.3048	= Meters (M)	M	x 3.281	= Feet
Yards	x 0.9144	= Meters (M)	M	x 1.0936	= Yards
Miles	x 1.6093	= Kilometers (Km)	Km	x 0.6214	= Miles
mph	x 1.6093	= Kilometers/Hr. (Km/h)	Km/h	x 0.6214	= mph
Feet/Sec.	x 0.3048	= Meters/Sec. (M/S)	M/S	x 3.281	= Feet/Sec.
Kilometers/Hr.	x 0.27778	= Meters/Sec. (M/S)	M/S	x 3.600	= Kilometers/Hr.
mph	x 0.4470	= Meters/Sec. (M/S)	M/S	x 2.237	= mph

COMMON METRIC EQUIVALENTS

1 Inch = 25 Millimeters	1 Cubic Inch = 16 Cubic Centimeters
1 Foot = 0.3 Meter	1 Cubic Foot = 0.03 Cubic Meter
1 Yard = 0.9 Meter	1 Cubic Yard = 0.8 Cubic Meter
1 Mile = 1.6 Kilometers	

GENERAL INFORMATION (Continued)

METRIC CONVERSION

in-lbs to N•m

N•m to in-lbs

Table with 20 columns and 20 rows of conversion data for in-lbs to N•m and N•m to in-lbs.

ft-lbs to N•m

N•m to ft-lbs

Table with 20 columns and 20 rows of conversion data for ft-lbs to N•m and N•m to ft-lbs.

in. to mm

mm to in.

Table with 16 columns and 20 rows of conversion data for in. to mm and mm to in.

GENERAL INFORMATION (Continued)**TORQUE REFERENCES**

Individual Torque Charts appear at the end of many Groups. Refer to the Standard Torque Specifi-

cations Chart for torque references not listed in the individual torque charts.

TORQUE SPECIFICATIONS**SPECIFIED TORQUE FOR STANDARD BOLTS**

Class	Diameter mm	Pitch mm	Specified torque					
			Hexagon head bolt			Hexagon flange bolt		
			N•m	kgf-cm	ft-lbf	N•m	kgf-cm	ft-lbf
4T	6	1	5	55	48 in.-lbf	6	60	52 in.-lbf
	8	1.25	12.5	130	9	14	145	10
	10	1.25	26	260	19	29	290	21
	12	1.25	47	480	35	53	540	39
	14	1.5	74	760	55	84	850	61
	16	1.5	115	1,150	83	—	—	—
5T	6	1	6.5	65	56 in.-lbf	7.5	75	65 in.-lbf
	8	1.25	15.5	160	12	17.5	175	13
	10	1.25	32	330	24	36	360	26
	12	1.25	59	600	43	65	670	48
	14	1.5	91	930	67	100	1,050	76
	16	1.5	140	1,400	101	—	—	—
6T	6	1	8	80	69 in.-lbf	9	90	78 in.-lbf
	8	1.25	19	195	14	21	210	15
	10	1.25	39	400	29	44	440	32
	12	1.25	71	730	53	80	810	59
	14	1.5	110	1,100	80	125	1,250	90
	16	1.5	170	1,750	127	—	—	—
7T	6	1	10.5	110	8	12	120	9
	8	1.25	25	260	19	28	290	21
	10	1.25	52	530	38	58	590	43
	12	1.25	95	970	70	105	1,050	76
	14	1.5	145	1,500	108	165	1,700	123
	16	1.5	230	2,300	166	—	—	—
8T	8	1.25	29	300	22	33	330	24
	10	1.25	61	620	45	68	690	50
	12	1.25	110	1,100	80	120	1,250	90
9T	8	1.25	34	340	25	37	380	27
	10	1.25	70	710	51	78	790	57
	12	1.25	125	1,300	94	140	1,450	105
10T	8	1.25	38	390	28	42	430	31
	10	1.25	78	800	58	88	890	64
	12	1.25	140	1,450	105	155	1,600	116
11T	8	1.25	42	430	31	47	480	35
	10	1.25	87	890	64	97	990	72
	12	1.25	155	1,600	116	175	1,800	130

INTRODUCTION

CONTENTS

	page		page
GENERAL INFORMATION		MANUFACTURER PLATE	2
E-MARK LABEL	2	VEHICLE IDENTIFICATION NUMBER (VIN)	1

GENERAL INFORMATION

VEHICLE IDENTIFICATION NUMBER (VIN)

The Vehicle Identification Number (VIN) plate is attached to the top left side of the instrument panel. The VIN contains 17 characters that provide data concerning the vehicle. Refer to the decoding chart to determine the identification of a vehicle. The Vehicle Identification Number is also imprinted on the:

- Body Code Plate.
- Equipment Identification Plate.
- Vehicle Safety Certification Label.
- Frame rail.

VEHICLE IDENTIFICATION NUMBER DECODING CHART

POSITION	INTERPRETATION	CODE = DESCRIPTION
1	Country of Origin	1 = United States or Austria
2	Make	J = Jeep
3	Vehicle Type	4 = MPV
4	Gross Vehicle Weight Rating	G = 5001-6000 lbs.
5	Vehicle Line	X = Grand Cherokee 4X2 (LHD) Z = Grand Cherokee 4X4 (LHD)/(RHD)
6	Transmission	B = 4 Speed Auto N = 5 Speed Manual
7	Body Style	8 = 4dr Sport Utility
8	Engine	M = 2.5 Liter Diesel S = 4.0 Liter Y = 5.2 Liter
9	Check Digit	
10	Model Year	W= 1998
11	Assembly Plant	Y = Steyr Assembly (Graz, Austria)
12 thru 17	Vehicle Build Sequence	

GENERAL INFORMATION (Continued)

E-MARK LABEL

An E-mark Label (Fig. 1) is located on the rear shut face of the driver's door. The label contains the following information:

- Date of Manufacture
- Month-Day-Hour (MDH)
- Vehicle Identification Number (VIN)
- Country Codes
- Regulation Number
- Regulation Amendment Number
- Approval Number

Date of Manufacture: 05-95 MDH: 052915					
VIN: XXXXXXXXXXXXXXXXXXXX					
E4	21	0195002	E11	13	063098
	26	0195001		14	030169
E5	10	010035	E11	17	040212
	11	020011		39	00155
	18	010010		44	0244038
	28	010016		51	011082
	46	010019		79	00155
	85	000044			
E11	12	030263	E11	48	005003

Country Code | Approval Number
 Regulation Number | Amendment Number

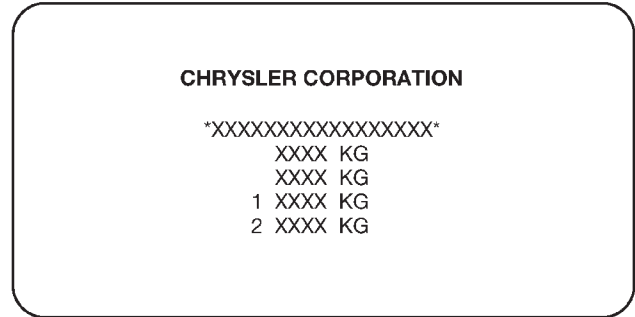
80a47175

Fig. 1 E-Mark Label

MANUFACTURER PLATE

The Manufacturer Plate (Fig. 2) is located in the engine compartment on the radiator closure panel crossmember adjacent to the Body Code Plate. The plate contains five lines of information:

1. Vehicle Identification Number (VIN)
2. Gross Vehicle Mass (GVM)
3. Gross Train Mass (GTM)
4. Gross Front Axle Rating (GFAR)
5. Gross Rear Axle Rating (GRAR)



80a47179

Fig. 2 Manufacturer Plate

LUBRICATION AND MAINTENANCE

CONTENTS

	page		page
GENERAL INFORMATION	1	MAINTENANCE SCHEDULES	3
JUMP STARTING, HOISTING AND TOWING	8		

GENERAL INFORMATION

INDEX

	page		page
GENERAL INFORMATION		INTRODUCTION	1
CLASSIFICATION OF LUBRICANTS	2	PARTS AND LUBRICANT	
FLUID CAPACITIES	2	RECOMMENDATIONS	1
INTERNATIONAL SYMBOLS	1		

GENERAL INFORMATION

INTRODUCTION

Service and maintenance procedures for components and systems listed in Schedule—A or B can be found by using the Group Tab Locator index at the front of this manual. If it is not clear which group contains the information needed, refer to the index at the back of this manual.

There are two maintenance schedules that show proper service based on the conditions that the vehicle is subjected to.

Schedule—A, lists scheduled maintenance to be performed when the vehicle is used for general transportation.

Schedule—B, lists maintenance intervals for vehicles that are operated under the conditions listed at the beginning of the Maintenance Schedule section.

Use the schedule that best describes your driving conditions.

Where time and mileage are listed, follow the interval that occurs first.








PARTS AND LUBRICANT RECOMMENDATIONS

When service is required, Chrysler Corporation recommends that only Mopar® brand parts, lubri-

cants and chemicals be used. Mopar provides the best engineered products for servicing Chrysler Corporation vehicles.

INTERNATIONAL SYMBOLS

Chrysler Corporation uses international symbols to identify engine compartment lubricant and fluid inspection and fill locations (Fig. 1).

 CHRYSLER CORPORATION			
	ENGINE OIL		BRAKE FLUID
	AUTOMATIC TRANSMISSION FLUID		POWER STEERING FLUID
	ENGINE COOLANT		WINDSHIELD WASHER FLUID

9500-1

Fig. 1 International Symbols

GENERAL INFORMATION (Continued)

CLASSIFICATION OF LUBRICANTS

Only lubricants that are endorsed by the following organization should be used to service a Chrysler Corporation vehicle.

- Society of Automotive Engineers (SAE)
- American Petroleum Institute (API) (Fig. 2)
- National Lubricating Grease Institute (NLGI) (Fig. 3)



Fig. 2 API Symbol

9400-9

ENGINE OIL

SAE VISCOSITY RATING INDICATES ENGINE OIL VISCOSITY

An SAE viscosity grade is used to specify the viscosity of engine oil. SAE 30 specifies a single viscosity engine oil. Engine oils also have multiple viscosities. These are specified with a dual SAE viscosity grade which indicates the cold-to-hot temperature viscosity range.

- SAE 30 = single grade engine oil.
- SAE 10W-30 = multiple grade engine oil.

API QUALITY CLASSIFICATION

The API Service Grade specifies the type of performance the engine oil is intended to provide. The API Service Grade specifications also apply to energy conserving engine oils.

Use engine oils that are API Service Certified. 5W-30 and 10W-30 MOPAR engine oils conform to specifications.

Refer to Group 9, Engine for engine oil specification.

GEAR LUBRICANTS

SAE ratings also apply to multiple grade gear lubricants. In addition, API classification defines the lubricants usage.

LUBRICANTS AND GREASES

Lubricating grease is rated for quality and usage by the NLGI. All approved products have the NLGI symbol (Fig. 3) on the label. At the bottom NLGI symbol is the usage and quality identification letters. Wheel bearing lubricant is identified by the letter "G". Chassis lubricant is identified by the latter "L".

The letter following the usage letter indicates the quality of the lubricant. The following symbols indicate the highest quality.

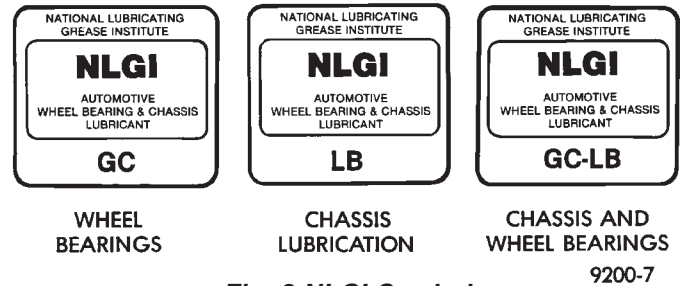


Fig. 3 NLGI Symbol

9200-7

FLUID CAPACITIES

FUEL TANK

All.87.4 L (23 gal.)

ENGINE OIL W/FILTER CHANGE

4.0L5.7 L (6.0 qts.)
 5.2L4.7 L (5.0 qts.)
 5.9L4.7 L (5.0 qts.)

COOLING SYSTEM

4.0L11.4 L (12.0 qts.)*
 5.2L14.1 L (14.9 qts.)*
 5.9L14.1 L (14.9 qts.)*
 *Includes 2.2 L (2.3 qts.) for coolant recovery bottle.

AUTOMATIC TRANSMISSION

Dry fill capacity.*

42RE & 44RE9.3-11.7L (19.5-22 pts.)
 46RE9.2-13.3 L (19.5-28 pts.)

*Depending on type and size of internal cooler, length and inside diameter of cooler lines, or use of an auxiliary cooler, these figures may vary. Refer to Group 21, Transmission for proper fluid fill procedure.

TRANSFER CASE

242 NVG1.4 L (3.0 pts.)
 249 NVG1.1 L (2.5 pts.)

FRONT AXLE

181 FBI1.18 L (2.5 pts.)

REAR AXLE

194 RBI*1.6 L (3.5 pts.)
 216 RBA*2.24 L (4.75 pts.)

*If the vehicle is equipped with TRAC-LOK, include 0.11 L (0.25 pts.) of friction modifier.

NOTE: Vehicles with trailer tow, must use a synthetic lubricant. Refer to Group 3, Differential and Driveline for service procedures.

MAINTENANCE SCHEDULES

INDEX

	page		page
GENERAL INFORMATION		SCHEDULE—B	5
INTRODUCTION	3	UNSCHEDULED INSPECTION	3
SCHEDULE—A	3		

GENERAL INFORMATION

INTRODUCTION

There are two maintenance schedules that show proper service intervals for ZJ vehicles. Use the schedule that best describes the conditions the vehicle is operated under. When mileage and time is listed, follow the interval that occurs first.

Schedule-A lists all the scheduled maintenance to be performed under normal operating conditions.

Schedule-B is a schedule for vehicles that are operated under the following conditions:

- Frequent short trips driving less than 5 miles (8 km)
- Frequent driving in dusty conditions
- Extensive idling
- Trailer towing
- Sustained high speed operation
- Off road driving
- Desert operation
- Frequent starting and stopping
- Cold climate operation
- Commercial service

EMISSION CONTROL SYSTEM MAINTENANCE

The scheduled emission maintenance listed in **bold type** on the Maintenance Schedules, must be done at the mileage specified to assure the continued proper functioning of the emission control system. These, and all other maintenance services included in this manual, should be done to provide the best vehicle performance and reliability. More frequent maintenance may be needed for vehicles in severe operating conditions such as dusty areas and very short trip driving.

UNSCHEDULED INSPECTION

AT EACH STOP FOR FUEL

- Check engine oil level, add as required.
- Check windshield washer solvent and add if required.

ONCE A MONTH

- Check tire pressure and look for unusual wear or damage.
- Inspect battery and clean and tighten terminals as required. Check electrolyte level and add water as needed.
- Check fluid levels of coolant reservoir, power steering and transmission and add as needed.
- Check all lights and all other electrical items for correct operation.

AT EACH OIL CHANGE

- Inspect exhaust system.
- Inspect brake hoses.
- Rotate the tires at each oil change interval shown on Schedule—A (7,500 miles) or every other interval shown on Schedule—B (6,000 miles).
 - Check coolant level, hoses and clamps.
 - Lubricate suspension ball joints.
 - After completion of off-road (4WD) operation, the underside of the vehicle should be thoroughly inspected. Examine threaded fasteners for looseness.

SCHEDULE—A

7,500 miles (12 000 km) or at 6 months

- Change engine oil.
- Replace engine oil filter.
- Lubricate steering linkage (4x4 only).

15,000 Miles (24 000 km) or at 12 months

- Change engine oil.
- Replace engine oil filter.
- Lubricate steering linkage.

22,500 Miles (36 000 km) or at 18 months

- Change engine oil.
- Replace engine oil filter.
- Lubricate steering linkage (4x4 only).
- Inspect brake linings.

30,000 Miles (48 000 km) or at 24 months

- Change engine oil.
- Replace engine oil filter.
- **Replace engine air cleaner element.**

GENERAL INFORMATION (Continued)

- **Replace spark plugs.**
- Inspect drive belt.
- Lubricate steering linkage.
- Drain and refill automatic transmission fluid.
- Drain and refill transfer case fluid.

37,500 Miles (60 000 km) or at 30 months

- Change engine oil.
- Replace engine oil filter.
- Lubricate steering linkage (4x4 only).

45,000 Miles (72 000 km) or at 36 months

- Change engine oil.
- Replace engine oil filter.
- Lubricate steering linkage.
- Inspect brake linings.
- Flush and replace engine coolant at 36 months, regardless of mileage.

52,500 Miles (84 000 km) or at 42 months

- Change engine oil.
- Replace engine oil filter.
- Lubricate steering linkage (4x4 only).
- Flush and replace engine coolant if not done at 36 months.

60,000 Miles (96 000 km) or at 48 months

- Change engine oil.
- Replace engine oil filter.
- **Replace engine air cleaner element.**
- **Replace ignition wires.**
- **Replace spark plugs.**
- **Inspect PCV valve and replace if necessary (5.2L & 5.9L only).***
- Inspect drive belt.
- Lubricate steering linkage.
- Drain and refill automatic transmission fluid.
- Drain and refill transfer case fluid.
- Replace fuel filter.**

67,500 Miles (108 000 km) or at 54 months

- Change engine oil.
- Replace engine oil filter.
- Lubricate steering linkage (4x4 only).
- Inspect brake linings.

75,000 Miles (120 000 km) or at 60 months

- Change engine oil.
- Replace engine oil filter.
- Lubricate steering linkage.
- Flush and replace engine coolant if it has been 30,000 miles (48 000 km) or 24 months since last change.

82,500 Miles (132 000 km) or at 66 months

- Change engine oil.
- Replace engine oil filter.

- Lubricate steering linkage (4x4 only).
- Flush and replace engine coolant if it has been 30,000 miles (48 000 km) or 24 months since last change.

90,000 Miles (144 000 km) or at 72 months

- Change engine oil.
- Replace engine oil filter.
- **Replace engine air cleaner element.**
- **Replace spark plugs.**
- Inspect drive belt.
- Lubricate steering linkage.
- Drain and refill automatic transmission fluid.
- Drain and refill transfer case fluid.
- Inspect brake linings.

97,500 Miles (156 000 km) or at 78 months

- Change engine oil.
- Replace engine oil filter.
- Lubricate steering linkage (4x4 only).

105,000 Miles (168 000 km) or at 84 months

- Change engine oil.
- Replace engine oil filter.
- Lubricate steering linkage.
- Flush and replace engine coolant if it has been 30,000 miles (48 000 km) or 24 months since last change.

112,500 Miles (180 000 km) or at 90 months

- Change engine oil.
- Replace engine oil filter.
- Lubricate steering linkage (4x4 only).
- Inspect brake linings.
- Flush and replace engine coolant if it has been 30,000 miles (48 000 km) or 24 months since last change.

120,000 Miles (192 000 km) or at 96 months

- Change engine oil.
- Replace engine oil filter.
- **Replace engine air cleaner element.**
- **Replace ignition wires.**
- **Replace spark plugs.**
- **Inspect PCV valve and replace if necessary (5.2L & 5.9L only).***
- Inspect drive belt.
- Lubricate steering linkage.
- Drain and refill automatic transmission fluid.
- Drain and refill transfer case fluid.
- Replace fuel filter.**

*This maintenance is recommended, but is not required to maintain warranty on the PCV valve.

**Recommended for proper vehicle performance for vehicles built for sale in California.

GENERAL INFORMATION (Continued)

IMPORTANT: Inspection and service should also be performed anytime a malfunction is observed or suspected.

SCHEDULE—B**3,000 Miles (5 000 km)**

- Change engine oil.
- Replace engine oil filter.
- Lubricate steering linkage (4x4 only).

6,000 Miles (10 000 km)

- Change engine oil.
- Replace engine oil filter.
- Lubricate steering linkage (4x4 only).

9,000 Miles (14 000 km)

- Change engine oil.
- Replace engine oil filter.
- Lubricate steering linkage (4x4 only).

12,000 Miles (19 000 km)

- Change engine oil.
- Replace engine oil filter.
- Drain and refill automatic transmission fluid.
- Drain and refill front and rear axles.
- Lubricate steering linkage (4x4 only).
- Inspect brake linings.

15,000 miles (24 000 km)

- Change engine oil.
- Replace engine oil filter.
- **Inspect engine air cleaner element, replace as necessary.**
- Lubricate steering linkage.

18,000 Miles (29 000 km)

- Change engine oil.
- Replace engine oil filter.
- Lubricate steering linkage (4x4 only).

21,000 Miles (34 000 km)

- Change engine oil.
- Replace engine oil filter.
- Lubricate steering linkage (4x4 only).

24,000 Miles (38 000 km)

- Change engine oil.
- Replace engine oil filter.
- Drain and refill automatic transmission fluid.
- Drain and refill front and rear axles.
- Lubricate steering linkage (4x4 only).
- Inspect brake linings.

27,000 Miles (43 000 km)

- Change engine oil.
- Replace engine oil filter.

- Lubricate steering linkage (4x4 only).

30,000 Miles (48 000 km)

- Change engine oil.
- Replace engine oil filter.
- **Replace engine air cleaner element.**
- **Inspect PCV valve and replace if necessary (5.2L & 5.9L only).***
- **Replace spark plugs.**
- Inspect drive belt.
- Drain and refill transfer case fluid.
- Lubricate steering linkage.

33,000 Miles (53 000 km)

- Change engine oil.
- Replace engine oil filter.
- Lubricate steering linkage (4x4 only).

36,000 Miles (58 000 km)

- Change engine oil.
- Replace engine oil filter.
- Drain and refill automatic transmission fluid.
- Drain and refill front and rear axles.
- Lubricate steering linkage (4x4 only).
- Inspect brake linings.

39,000 Miles (62 000 km)

- Change engine oil.
- Replace engine oil filter.
- Lubricate steering linkage (4x4 only).

42,000 Miles (67 000 km)

- Change engine oil.
- Replace engine oil filter.
- Lubricate steering linkage (4x4 only).

45,000 Miles (72 000 km)

- Change engine oil.
- Replace engine oil filter.
- **Inspect engine air cleaner element, replace as necessary.**
- Lubricate steering linkage.

48,000 Miles (77 000 km)

- Change engine oil.
- Replace engine oil filter.
- Drain and refill automatic transmission fluid.
- Drain and refill front and rear axles.
- Lubricate steering linkage (4x4 only).
- Inspect brake linings.

51,000 Miles (82 000 km)

- Change engine oil.
- Replace engine oil filter.
- Flush and replace engine coolant.
- Lubricate steering linkage (4x4 only).

GENERAL INFORMATION (Continued)**54,000 Miles (86 000 km)**

- Change engine oil.
- Replace engine oil filter.
- Lubricate steering linkage (4x4 only).

57,000 Miles (91 000 km)

- Change engine oil.
- Replace engine oil filter.
- Lubricate steering linkage (4x4 only).

60,000 Miles (96 000 km)

- Change engine oil.
- Replace engine oil filter.
- **Replace engine air cleaner element.**
- **Replace ignition wires.**
- **Inspect PCV valve and replace if necessary (5.2L & 5.9L only).***
- Replace spark plugs.
- Inspect drive belt.
- Drain and refill automatic transmission fluid.
- Drain and refill transfer case fluid.
- Drain and refill front and rear axles.
- Lubricate steering linkage.
- Replace fuel filter.**
- Inspect brake linings.

63,000 Miles (101 000 km)

- Change engine oil.
- Replace engine oil filter.
- Lubricate steering linkage (4x4 only).

66,000 Miles (106 000 km)

- Change engine oil.
- Replace engine oil filter.
- Lubricate steering linkage (4x4 only).

69,000 Miles (110 000 km)

- Change engine oil.
- Replace engine oil filter.
- Lubricate steering linkage (4x4 only).

72,000 Miles (115 000 km)

- Change engine oil.
- Replace engine oil filter.
- Drain and refill automatic transmission fluid.
- Drain and refill front and rear axles.
- Lubricate steering linkage (4x4 only).
- Inspect brake linings.

75,000 Miles (120 000 km)

- Change engine oil.
- Replace engine oil filter.
- **Inspect engine air cleaner element, replace as necessary.**
- Lubricate steering linkage.

78,000 Miles (125 000 km)

- Change engine oil.
- Replace engine oil filter.
- Lubricate steering linkage (4x4 only).

81,000 Miles (130 000 km)

- Change engine oil.
- Replace engine oil filter.
- Flush and replace engine coolant.
- Lubricate steering linkage (4x4 only).

84,000 miles (134 000 km)

- Change engine oil.
- Replace engine oil filter.
- Drain and refill automatic transmission fluid.
- Drain and refill front and rear axles.
- Lubricate steering linkage (4x4 only).
- Inspect brake linings.

87,000 Miles (139 000 km)

- Change engine oil.
- Replace engine oil filter.
- Lubricate steering linkage (4x4 only).

90,000 Miles (144 000 km)

- Change engine oil.
- Replace engine oil filter.
- **Replace engine air cleaner element.**
- **Inspect PCV valve and replace if necessary (5.2L & 5.9L only).***
- **Replace spark plugs.**
- Inspect drive belt.
- Drain and refill transfer case fluid.
- Lubricate steering linkage.

93,000 Miles (149 000 km)

- Change engine oil.
- Replace engine oil filter.
- Lubricate steering linkage (4x4 only).

96,000 Miles (154 000 km)

- Change engine oil.
- Replace engine oil filter.
- Drain and refill automatic transmission fluid.
- Drain and refill front and rear axles.
- Lubricate steering linkage (4x4 only).
- Inspect brake linings.

99,000 Miles (158 000 km)

- Change engine oil.
- Replace engine oil filter.
- Lubricate steering linkage (4x4 only).

102,000 Miles (163 000 km)

- Change engine oil.
- Replace engine oil filter.
- Lubricate steering linkage (4x4 only).

GENERAL INFORMATION (Continued)**105,000 Miles (168 000 km)**

- Change engine oil.
- Replace engine oil filter.
- **Inspect engine air cleaner element, replace as necessary.**
- Lubricate steering linkage.

108,000 Miles (173 000 km)

- Change engine oil.
- Replace engine oil filter.
- Drain and refill automatic transmission fluid.
- Drain and refill front and rear axles.
- Lubricate steering linkage (4x4 only).
- Inspect brake linings.

111,000 Miles (178 000 km)

- Change engine oil.
- Replace engine oil filter.
- Flush and replace engine coolant.
- Lubricate steering linkage (4x4 only).

114,000 Miles (182 000 km)

- Change engine oil.
- Replace engine oil filter.
- Lubricate steering linkage (4x4 only).

117,000 Miles (187 000 km)

- Change engine oil.
- Replace engine oil filter.

- Lubricate steering linkage (4x4 only).

120,000 Miles (192 000 km)

- Change engine oil.
- Replace engine oil filter.
- **Replace engine air cleaner element.**
- **Replace ignition wires.**
- **Replace spark plugs.**
- **Inspect PCV valve and replace if necessary (5.2L & 5.9L only).**
- Inspect drive belt.
- Drain and refill automatic transmission fluid.
- Drain and refill transfer case fluid.
- Drain and refill front and rear axles.
- Lubricate steering linkage.
- Replace fuel filter.**
- Inspect brake linings.

*This maintenance is recommended, but is not required to maintain warranty on the PCV valve.

**Recommended for proper vehicle performance for vehicles built for sale in California.

IMPORTANT: Inspection and service should also be performed anytime a malfunction is observed or suspected.

JUMP STARTING, HOISTING AND TOWING

INDEX

	page		page
SERVICE PROCEDURES		JUMP STARTING PROCEDURE	8
EMERGENCY TOW HOOKS	10	TOWING RECOMMENDATIONS	9
FOUR-WHEEL-DRIVE VEHICLE TOWING	10	TWO-WHEEL-DRIVE VEHICLE TOWING	9
HOISTING RECOMMENDATIONS	10		

SERVICE PROCEDURES

JUMP STARTING PROCEDURE

WARNING: REVIEW ALL SAFETY PRECAUTIONS AND WARNINGS IN GROUP 8A, BATTERY/STARTING/CHARGING SYSTEMS DIAGNOSTICS. DO NOT JUMP START A FROZEN BATTERY, PERSONAL INJURY CAN RESULT. DO NOT JUMP START WHEN MAINTENANCE FREE BATTERY INDICATOR DOT IS YELLOW OR BRIGHT COLOR. DO NOT JUMP START A VEHICLE WHEN THE BATTERY FLUID IS BELOW THE TOP OF LEAD PLATES. DO NOT ALLOW JUMPER CABLE CLAMPS TO TOUCH EACH OTHER WHEN CONNECTED TO A BOOSTER SOURCE. DO NOT USE OPEN FLAME NEAR BATTERY. REMOVE METALLIC JEWELRY WORN ON HANDS OR WRISTS TO AVOID INJURY BY ACCIDENTAL ARCING OF BATTERY CURRENT. WHEN USING A HIGH OUTPUT BOOSTING DEVICE, DO NOT ALLOW BATTERY VOLTAGE TO EXCEED 16 VOLTS. REFER TO INSTRUCTIONS PROVIDED WITH DEVICE BEING USED.

CAUTION: When using another vehicle as a booster, do not allow vehicles to touch. Electrical systems can be damaged on either vehicle.

TO JUMP START A DISABLED VEHICLE:

(1) Raise hood on disabled vehicle and visually inspect engine compartment for:

- Battery cable clamp condition, clean if necessary.
- Frozen battery.
- Yellow or bright color test indicator, if equipped.
- Low battery fluid level.
- Generator drive belt condition and tension.
- Fuel fumes or leakage, correct if necessary.

CAUTION: If the cause of starting problem on disabled vehicle is severe, damage to booster vehicle charging system can result.

(2) When using another vehicle as a booster source, park the booster vehicle within cable reach. Turn off all accessories, set the parking brake, place the automatic

transmission in PARK or the manual transmission in NEUTRAL and turn the ignition OFF.

(3) On disabled vehicle, place gear selector in park or neutral and set park brake. Turn off all accessories.

(4) Connect jumper cables to booster battery. RED clamp to positive terminal (+). BLACK clamp to negative terminal (-). DO NOT allow clamps at opposite end of cables to touch, electrical arc will result. Review all warnings in this procedure.

(5) On disabled vehicle, connect RED jumper cable clamp to positive (+) terminal. Connect BLACK jumper cable clamp to engine ground as close to the ground cable attaching point as possible (Fig. 1).

(6) Start the engine in the vehicle which has the booster battery, let the engine idle a few minutes, then start the engine in the vehicle with the discharged battery.

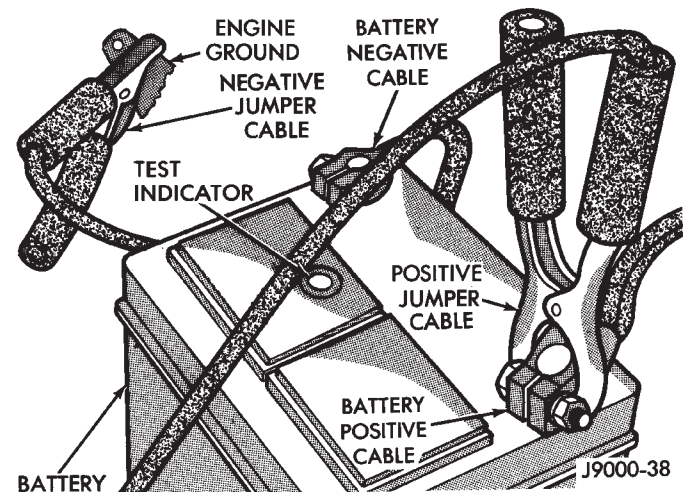


Fig. 1 Jumper Cable Clamp Connections

CAUTION: Do not crank starter motor on disabled vehicle for more than 15 seconds, starter will over-heat and could fail.

(7) Allow battery in disabled vehicle to charge to at least 12.4 volts (75% charge) before attempting to start engine. If engine does not start within 15 seconds, stop cranking engine and allow starter to cool (15 min.), before cranking again.

SERVICE PROCEDURES (Continued)

DISCONNECT CABLE CLAMPS AS FOLLOWS:

- Disconnect BLACK cable clamp from engine ground on disabled vehicle.
- When using a Booster vehicle, disconnect BLACK cable clamp from battery negative terminal. Disconnect RED cable clamp from battery positive terminal.
- Disconnect RED cable clamp from battery positive terminal on disabled vehicle.

TOWING RECOMMENDATIONS

A vehicle equipped with SAE approved sling-type towing equipment or a wheel-lift towing device can be used to tow all ZJ vehicles. When towing a 4WD vehicle, use tow dollies under the opposite end of the vehicle. A vehicle with a flat-bed device can also be used to transport a disabled vehicle (Fig. 2).

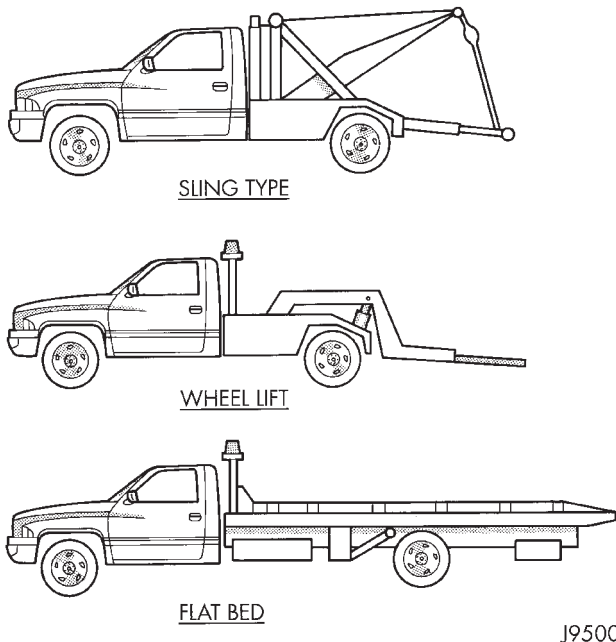


Fig. 2 Tow Vehicles With Approved Equipment.

SAFETY PRECAUTIONS

The following safety precautions must be observed when towing a vehicle:

- Secure loose and protruding parts.
- Always use a safety chain system that is independent of the lifting and towing equipment.
- Do not allow towing equipment to contact the disabled vehicle's fuel tank.
- Do not allow anyone under the disabled vehicle while it is lifted by the towing device.
- Do not allow passengers to ride in a vehicle being towed.
- Always observe state and local laws regarding towing regulations.
- Do not tow a vehicle in a manner that could jeopardize the safety of the operator, pedestrians or other motorists.

- Do not attach tow chains, T-hooks, J-hooks, or a tow sling to a bumper, steering linkage, drive shafts or a non-reinforced frame hole.

GROUND CLEARANCE

CAUTION: If vehicle is towed with wheels removed, install lug nuts to retain brake drums.

A towed vehicle should be raised until lifted wheels are a minimum 100 mm (4 in) from the ground. Be sure there is adequate ground clearance at the opposite end of the vehicle, especially when towing over rough terrain or steep rises in the road. If necessary, remove the wheels from the lifted end of the vehicle and lower the vehicle closer to the ground, to increase the ground clearance at the opposite end of the vehicle. Install lug nuts on wheel attaching studs to retain brake drums.

FLAT-BED TOWING RAMP ANGLE

If a vehicle with flat-bed towing equipment is used, the approach ramp angle should not exceed 15 degrees.

TWO-WHEEL-DRIVE VEHICLE TOWING

Chrysler Corporation recommends that a vehicle be towed with the rear end lifted, whenever possible.

WARNING: WHEN TOWING A DISABLED VEHICLE AND THE DRIVE WHEELS ARE SECURED IN A WHEEL LIFT OR TOW DOLLIES, ENSURE THE TRANSMISSION IS IN THE PARK POSITION (AUTOMATIC TRANSMISSION) OR A FORWARD DRIVE GEAR (MANUAL TRANSMISSION).

TOWING-REAR END LIFTED

CAUTION: Do not use steering column lock to secure steering wheel during towing operation.

Vehicles can be towed with the front wheels on the ground for extended distances at speeds not exceeding 48 km/h (30 mph).

- (1) Attach the J-hooks around the axle shaft tube outboard of the rear springs.
- (2) Position and center the sling under and forward of the rear bumper.
- (3) Attach safety chains (with pads) at each end of the rear bumper.
- (4) Turn the ignition switch to the OFF position to unlock the steering wheel.
- (5) Secure the steering wheel in straight ahead position with a clamp device designed for towing.
- (6) Verify that steering components are in good condition.
- (7) Shift the transmission to NEUTRAL.

SERVICE PROCEDURES (Continued)**TOWING-FRONT END LIFTED**

To prevent damage to front fascia components, use only a Wheel-Lift type towing device or Flat-Bed hauling equipment.

If using the wheel-lift towing method, install tow dollies under rear wheels.

FOUR-WHEEL-DRIVE VEHICLE TOWING

Chrysler Corporation recommends that a vehicle be transported on a flat-bed device. A Wheel-lift or Sling-type device can be used provided all the wheels are lifted off the ground using tow dollies.

WARNING: WHEN TOWING A DISABLED VEHICLE AND THE DRIVE WHEELS ARE SECURED IN A WHEEL LIFT OR TOW DOLLIES, ENSURE THE TRANSMISSION IS IN THE PARK POSITION (AUTOMATIC TRANSMISSION) OR A FORWARD DRIVE GEAR (MANUAL TRANSMISSION).

4WD TOWING-REAR END LIFTED

(1) Raise the front of the vehicle off the ground and install tow dollies under front wheels.

(2) Attach the J-hooks around the axle shaft tube outboard of the rear springs.

(3) Position and center the sling under and forward of the rear bumper.

(4) Attach safety chains (with pads) at each end of the rear bumper.

(5) Turn the ignition switch to the OFF position to unlock the steering wheel.

(6) Secure the steering wheel in straight ahead position with a clamp device designed for towing.

4WD TOWING-FRONT END LIFTED

To prevent damage to front fascia components, use only a Wheel-Lift type towing device or Flat-Bed hauling equipment.

If using the wheel-lift towing method, install tow dollies under rear wheels.

EMERGENCY TOW HOOKS

WARNING: REMAIN AT A SAFE DISTANCE FROM A VEHICLE THAT IS BEING TOWED VIA ITS TOW HOOKS. THE TOW STRAPS/CHAINS COULD BREAK AND CAUSE SERIOUS INJURY.

Some Jeep vehicles are equipped with front emergency tow hooks. The tow hooks should be used for **EMERGENCY** purposes only.

CAUTION: DO NOT use emergency tow hooks for tow truck hook-up or highway towing.

HOISTING RECOMMENDATIONS**FLOOR JACK**

When properly positioned, a floor jack can be used to lift a ZJ vehicle (Fig. 3). Support the vehicle in the raised position with jack stands at the front and rear ends of the frame rails.

CAUTION: Do not attempt to lift a vehicle with a floor jack positioned under:

- An axle tube.
- Aluminum differential.
- A body side sill.
- A steering linkage component.
- A drive shaft.
- The engine or transmission oil pan.
- The fuel tank.
- A front suspension arm.

HOIST

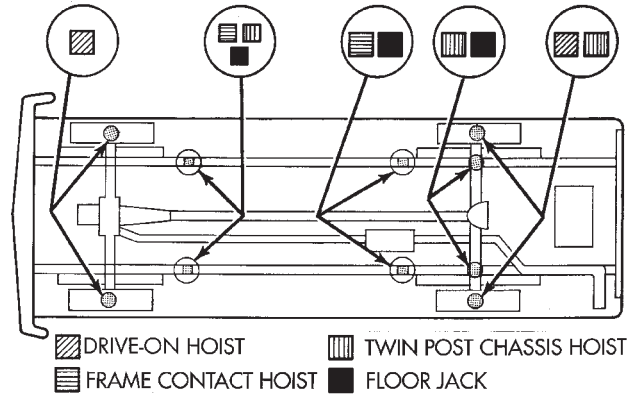
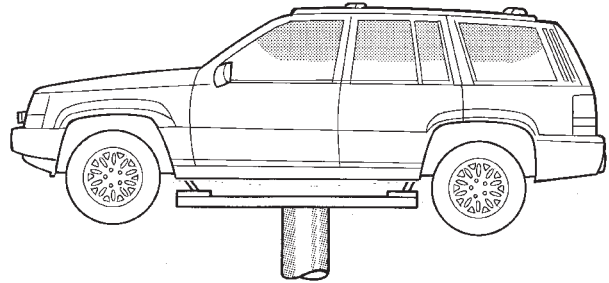
A vehicle can be lifted with:

- A single-post, frame-contact hoist.
- A twin-post, chassis hoist.
- A ramp-type, drive-on hoist.

SERVICE PROCEDURES (Continued)

NOTE: When a frame-contact type hoist is used, verify that the lifting pads are positioned properly (Fig. 3).

WARNING: THE HOISTING AND JACK LIFTING POINTS PROVIDED ARE FOR A COMPLETE VEHICLE. WHEN A CHASSIS OR DRIVETRAIN COMPONENT IS REMOVED FROM A VEHICLE, THE CENTER OF GRAVITY IS ALTERED MAKING SOME HOISTING CONDITIONS UNSTABLE. PROPERLY SUPPORT OR SECURE VEHICLE TO HOISTING DEVICE WHEN THESE CONDITIONS EXIST.



J9500-22

Fig. 3 Correct Vehicle Lifting Locations

LUBRICATION AND MAINTENANCE

CONTENTS

	page		page
GENERAL INFORMATION	1	MAINTENANCE SCHEDULE	2

GENERAL INFORMATION

INDEX

	page		page
SPECIFICATIONS		FLUID CAPACITIES	1
ENGINE OIL—DIESEL ENGINES	1		

SPECIFICATIONS

ENGINE OIL—DIESEL ENGINES

Use only Diesel Engine Oil meeting standard **MIL-2104C** or API Classification **SG/CD** or **CCMC PD2**.

SAE VISCOSITY GRADE

CAUTION: Low viscosity oils must have the proper API quality or the **CCMC G5** designation.

To assure of properly formulated engine oils, it is recommended that SAE Grade 15W-40 engine oils that meet Chrysler material standard MS-6395, be used. European Grade 10W-40 oils are also acceptable.

Oils of the SAE 5W-30 or 10W-30 grade number are preferred when minimum temperatures consistently fall below -12°C.

FLUID CAPACITIES

FUEL TANK

Diesel Engine Equipped Vehicles 87.4 L

ENGINE OIL

2.5L Diesel Engine (includes filter) 6.5 L

COOLING SYSTEM

2.5L Diesel 9.8 L

MANUAL TRANSMISSION

Recommended lubricant for AX15 transmissions is Mopar® 75W-90, API Grade GL-3 gear lubricant, or equivalent.

Correct lubricant level is from the bottom edge, to no more than 6 mm (1/4 in.) below the bottom edge of the fill plug hole.

Approximate dry fill lubricant capacity is:

- 3.10 liters (3.27 qts.) for 4-wheel drive applications.
- 3.15 liters (3.32 qts.) for 2-wheel drive applications.

TRANSFER CASE

NV231 1.8 L

FRONT AXLE

Model 181 1.48 L

MAINTENANCE SCHEDULE

INDEX

	page	page
GENERAL INFORMATION		
MAINTENANCE SCHEDULE—DIESEL ENGINE	2	
SCHEDULE—A		2
SCHEDULE—B		3

GENERAL INFORMATION

MAINTENANCE SCHEDULE—DIESEL ENGINE

The following are engine related Maintenance items which are unique to Diesel engine-equipped vehicles. Refer to the 1997 ZJ Service Manual for gasoline engine and non-engine related Maintenance Schedules.

The service intervals are based on odometer readings in kilometers. There are two maintenance schedules that show proper service intervals. Use the schedule that best describes the conditions the vehicle is operated under. **Schedule-A** lists all the scheduled maintenance to be performed under normal operating conditions. **Schedule-B** is the schedule for vehicles that are operated under one or more of the following conditions:

- Day and night temperatures are below freezing.
- Stop and go driving.
- Long periods of engine idling.
- Driving in dusty conditions.
- Short trips of less than 8 kilometers (5 miles).
- Operation at sustained high speeds during hot weather above 32°C (90°F).
- Taxi, police or delivery service.
- Trailer towing.

AT EACH STOP FOR FUEL OR SCHEDULED SERVICE STOP

- Check engine oil level.
- Check engine coolant level.
- Inspect drive belt.
- Visually inspect intercooler for obstruction. Clean as necessary.
- Visually inspect radiator for obstruction. Clean as necessary.
- Inspect for fuel, oil or coolant leaks.
- Inspect battery cable connection and excessive corrosion.
- Inspect for presence of water in fuel filter/water separator, drain if necessary.

SCHEDULE—A

1 000 KM

- Change engine oil.
- Change engine oil filter.

- Check all fluid levels.
- Check correct torque, intake manifold mounting nuts.
- Check correct torque, exhaust manifold mounting nuts.
- Check correct torque, turbocharger mounting nuts.
- Check correct torque, water manifold bolts.

10 000 KM

- Change engine oil.
- Change engine oil filter.

20 000 KM

- Change engine oil.
- Change engine oil filter.
- Replace air filter element.
- Check drive belt tension.
- Check glow plug operation.
- **Retorque cylinder head bolts.***

* Engines equipped with a steel head gasket do not need this service procedure performed. Refer to Group 9, Engines for head gasket identification.

30 000 KM

- Change engine oil.
- Change engine oil filter.

40 000 KM

- Change engine oil.
- Change engine oil filter.
- Replace air filter element.
- Check drive belt tension.
- Check glow plug operation.
- Replace fuel filter/water separator element.**

50 000 KM

- Change engine oil.
- Change engine oil filter.

GENERAL INFORMATION (Continued)**60 000 KM**

- Change engine oil.
- Change engine oil filter.
- Replace air filter element.
- Check glow plug operation.
- Replace drive belt.
- Check engine smoke.
- Replace engine coolant.

70 000 KM

- Change engine oil.
- Change engine oil filter.

80 000 KM

- Change engine oil.
- Change engine oil filter.
- Replace air filter element.
- Check drive belt tension.
- Check glow plug operation.
- Replace fuel filter/water separator element.**

90 000 KM

- Change engine oil.
- Change engine oil filter.

100 000 KM

- Change engine oil.
- Change engine oil filter.
- Replace air filter element.
- Check drive belt tension.
- Check glow plug operation.

EVERY 40 000 KM AFTER 80 000 KM

- Replace fuel filter/water separator element.**

**The fuel filter/water separator element should be replaced once a year if the vehicle is driven less than 40 000 km annually or if power loss from fuel starvation is detected.

EVERY 10 000 KM AFTER 100 000 KM

- Change engine oil.
- Change engine oil filter.

EVERY 20 000 KM AFTER 100 000 KM

- Change engine oil.
- Change engine oil filter.
- Replace air filter element.
- Check drive belt tension.
- Check glow plug operation.

SCHEDULE—B**500 KM**

- Check correct torque, intake manifold mounting nuts.
- Check correct torque, exhaust manifold mounting nuts.

- Check correct torque, turbocharger mounting nuts.
- Check correct torque, water manifold bolts.

1 000 KM

- Change engine oil.
- Change engine oil filter.
- Check all fluid levels.

5 000 KM

- Change engine oil.
- Change engine oil filter.

10 000 KM

- Change engine oil.
- Change engine oil filter.
- Replace air filter element.
- Check drive belt tension.
- Check glow plug operation.

15 000 KM

- Change engine oil.
- Change engine oil filter.

20 000 KM

- Change engine oil.
- Change engine oil filter.
- Replace air filter element.
- Check drive belt tension.
- Check glow plug operation.
- **Retorque cylinder head bolts.***

* Engines equipped with a steel head gasket do not need this service procedure performed. Refer to Group 9, Engines for head gasket identification.

25 000 KM

- Change engine oil.
- Change engine oil filter.

30 000 KM

- Change engine oil.
- Change engine oil filter.
- Replace air filter element.
- Check glow plug operation.
- Replace drive belt.
- Check engine smoke.
- Replace engine coolant.

35 000 KM

- Change engine oil.
- Change engine oil filter.

40 000 KM

- Change engine oil.
- Change engine oil filter.
- Replace air filter element.
- Check drive belt tension.

GENERAL INFORMATION (Continued)

- Check glow plug operation.
- Replace fuel filter/water separator element.

45 000 KM

- Change engine oil.
- Change engine oil filter.

50 000 KM

- Change engine oil.
- Change engine oil filter.
- Replace air filter element.
- Check drive belt tension.
- Check glow plug operation.

55 000 KM

- Change engine oil.
- Change engine oil filter.

60 000 KM

- Change engine oil.
- Change engine oil filter.
- Replace air filter element.
- Check drive belt tension.
- Check glow plug operation.
- Replace fuel filter/water separator element.

65 000 KM

- Change engine oil.
- Change engine oil filter.

70 000 KM

- Change engine oil.
- Change engine oil filter.
- Replace air filter element.
- Check drive belt tension.
- Check glow plug operation.

75 000 KM

- Change engine oil.
- Change engine oil filter.

80 000 KM

- Change engine oil.
- Change engine oil filter.

- Replace air filter element.
- Check glow plug operation.
- Replace drive belt.
- Check engine smoke.
- Replace engine coolant.

85 000 KM

- Change engine oil.
- Change engine oil filter.

90 000 KM

- Change engine oil.
- Change engine oil filter.
- Replace air filter element.
- Check drive belt tension.
- Check glow plug operation.

95 000 KM

- Change engine oil.
- Change engine oil filter.

100 000 KM

- Change engine oil.
- Change engine oil filter.
- Replace air filter element.
- Check drive belt tension.
- Check glow plug operation.
- Replace fuel filter/water separator element.

EVERY 5 000 KM AFTER 100 000 KM

- Change engine oil.
- Change engine oil filter.

EVERY 10 000 KM AFTER 100 000 KM

- Change engine oil.
- Change engine oil filter.
- Replace air filter element.
- Check drive belt tension.
- Check glow plug operation.

EVERY 20 000 KM AFTER 100 000 KM

- Replace fuel filter/water separator element.

SUSPENSION

CONTENTS

	page		page
ALIGNMENT	1	REAR SUSPENSION	14
FRONT SUSPENSION	6		

ALIGNMENT

INDEX

	page		page
GENERAL INFORMATION		WHEEL ALIGNMENT	3
WHEEL ALIGNMENT	1	SPECIFICATIONS	
DIAGNOSIS AND TESTING		ALIGNMENT	5
SUSPENSION AND STEERING SYSTEM	3		
SERVICE PROCEDURES			
PRE-ALIGNMENT	3		

GENERAL INFORMATION

WHEEL ALIGNMENT

Wheel alignment involves the correct positioning of the wheels in relation to the vehicle. The positioning is accomplished through suspension and steering linkage adjustments. An alignment is considered essential for efficient steering, good directional stability and to minimize tire wear. The most important measurements of an alignment are caster, camber and toe position (Fig. 1).

- **CASTER** is the forward or rearward tilt of the steering knuckle from vertical. Tilting the top of the knuckle rearward provides positive caster. Tilting the top of the knuckle forward provides negative caster. Caster is a directional stability angle. This angle enables the front wheels to return to a straight ahead position after turns.

- **CAMBER** is the inward or outward tilt of the wheel relative to the center of the vehicle. Tilting the top of the wheel inward provides negative camber. Tilting the top of the wheel outward provides positive camber. Incorrect camber will cause wear on the inside or outside edge of the tire. The angle is not adjustable, damaged component(s) must be replaced to correct the camber angle.

- **WHEEL TOE POSITION** is the difference between the leading inside edges and trailing inside edges of the front tires. Incorrect wheel toe position is the most common cause of unstable steering and uneven tire wear. The wheel toe position is the **final** front wheel alignment adjustment.

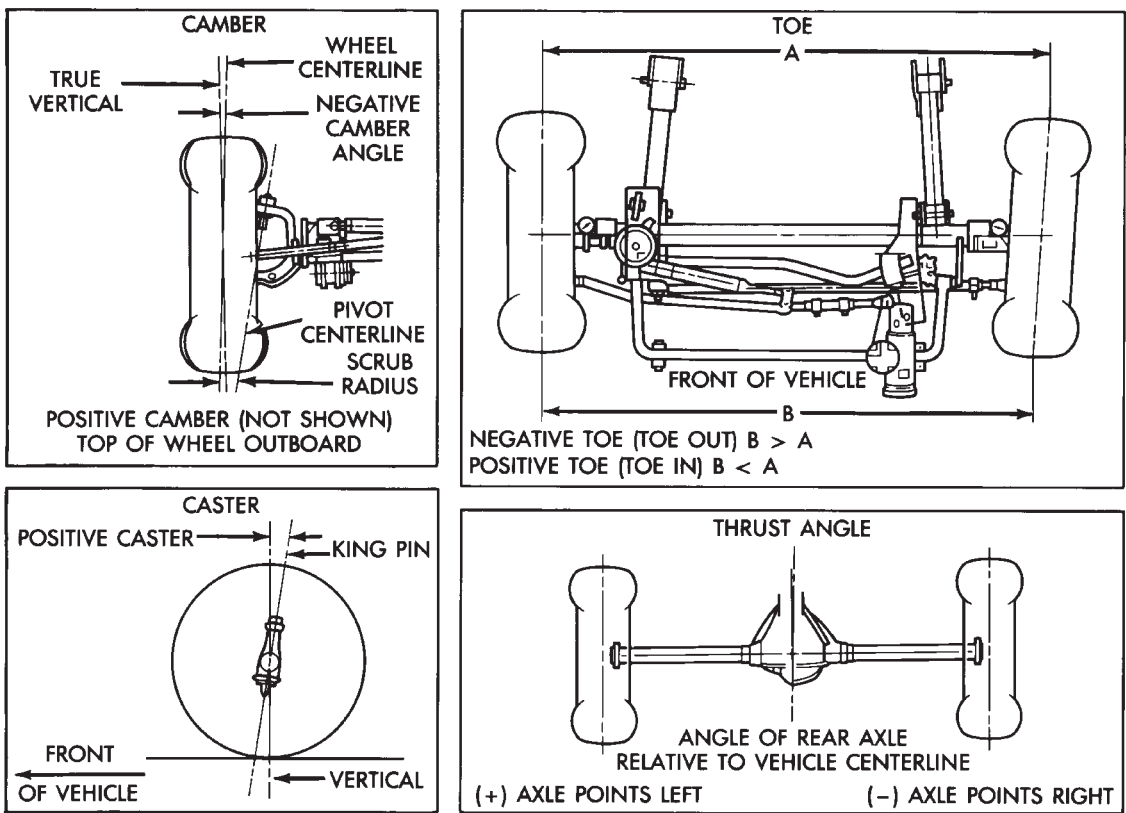
GENERAL INFORMATION (Continued)

- **STEERING AXIS INCLINATION ANGLE** is measured in degrees and is the angle that the steering knuckles are tilted. The inclination angle has a fixed relationship with the camber angle. It will not change except when a spindle or ball stud is damaged or bent. The angle is not adjustable, damaged component(s) must be replaced to correct the steering axis inclination angle.

- **THRUST ANGLE** is the angle of the rear axle relative to the centerline of the vehicle. Incorrect thrust angle can cause off-center steering and excessive tire wear. This angle is not adjustable, damaged component(s) must be replaced to correct the thrust angle.

CAUTION: Never attempt to modify suspension or steering components by heating or bending.

NOTE: Periodic lubrication of the front suspension/steering system components may be required. Rubber bushings must never be lubricated. Refer to Group 0, Lubrication And Maintenance for the recommended maintenance schedule.



J9402-57

Fig. 1 Wheel Alignment Measurements

DIAGNOSIS AND TESTING**SUSPENSION AND STEERING SYSTEM**

CONDITION	POSSIBLE CAUSES	CORRECTION
FRONT END NOISE	1. Loose or worn wheel bearings. 2. Loose or worn steering or suspension components.	1. Adjust or replace wheel bearings. 2. Tighten or replace components as necessary.
EXCESSIVE PLAY IN STEERING	1. Loose or worn wheel bearings. 2. Loose or worn steering or suspension components. 3. Loose or worn steering gear.	1. Adjust or replace wheel bearings. 2. Tighten or replace components as necessary. 3. Adjust or replace steering gear.
FRONT WHEELS SHIMMY	1. Loose or worn wheel bearings. 2. Loose or worn steering or suspension components. 3. Tires worn or out of balance. 4. Alignment. 5. Leaking steering dampener.	1. Adjust or replace wheel bearings. 2. Tighten or replace components as necessary. 3. Replace or balance tires. 4. Align vehicle to specifications. 5. Replace steering dampener.
VEHICLE INSTABILITY	1. Loose or worn wheel bearings. 2. Loose or worn steering or suspension components. 3. Tire pressure. 4. Alignment.	1. Adjust or replace wheel bearings. 2. Tighten or replace components as necessary. 3. Adjust tire pressure. 4. Align vehicle to specifications.
EXCESSIVE STEERING EFFORT	1. Loose or worn steering gear. 2. Power steering fluid low. 3. Column coupler binding. 4. Tire pressure. 5. Alignment.	1. Adjust or replace steering gear. 2. Add fluid and repair leak. 3. Replace coupler. 4. Adjust tire pressure. 5. Align vehicle to specifications.
VEHICLE PULLS TO ONE SIDE	1. Tire pressure. 2. Alignment. 3. Loose or worn steering or suspension components. 4. Radial tire lead. 5. Brake pull. 6. Weak or broken spring.	1. Adjust tire pressure. 2. Align vehicle to specifications. 3. Tighten or replace components as necessary. 4. Rotate or replace tire as necessary. 5. Repair brake as necessary. 6. Replace spring.

SERVICE PROCEDURES**PRE-ALIGNMENT**

Before starting wheel alignment, the following inspection and necessary corrections must be completed. Refer to Suspension and Steering System Diagnosis Chart for additional information.

- (1) Inspect tires for size, air pressure and tread wear.
- (2) Inspect front wheel bearings for wear.
- (3) Inspect front wheels for excessive radial or lateral runout and balance.
- (4) Inspect ball studs, linkage pivot points and steering gear for looseness, roughness or binding.
- (5) Inspect suspension components for wear and noise.

WHEEL ALIGNMENT

Before each alignment reading the vehicle should be jounced (rear first, then front). Grasp each bumper at the center and jounce the vehicle up and down three times. Always release the bumper in the down position.

To obtain an accurate alignment, a 4 wheel alignment machine must be used and the equipment calibration verified.

SERVICE PROCEDURES (Continued)**CAMBER**

The wheel camber angle is preset. This angle is not adjustable and cannot be altered.

CASTER

Before checking the caster angle of the front axle, be sure the axle is not bent or twisted. Road test the vehicle and observe the steering wheels ability to return-to-center after left and right hand turns. A low or negative caster angle will cause the steering wheel poor return-to-center ability.

Caster is adjusted by loosening and rotating the cams on the lower suspension arm (Fig. 2).

NOTE: Changing caster angle will also change the front propeller shaft angle. The propeller shaft angle has priority over caster. Refer to Group 3, Differential and Driveline for additional information.

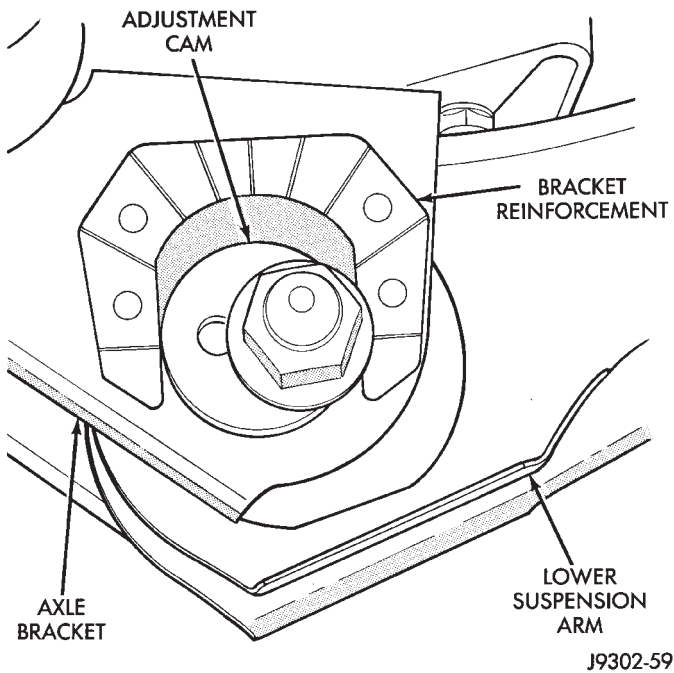


Fig. 2 Cam Adjuster

TOE POSITION

NOTE: The wheel toe position adjustment is the final adjustment. The adjustment must be performed with the engine running.

- (1) Apply parking brakes.
- (2) Start the engine and turn wheels both ways before straightening the steering wheel. Center and secure the steering wheel.

- (3) Loosen the adjustment sleeve clamp bolts (Fig. 3).

- (4) Adjust the right wheel toe position with the drag link (Fig. 4) and (Fig. 5). Turn the sleeve until the right wheel is at the preferred positive TOE-IN specification. Position the clamp bolts as shown (Fig. 3) and tighten to 49 N-m (36 ft. lbs.).

NOTE: Tighten clamp bolt nearest the pitman arm first. Make sure the toe setting does not change during clamp tightening.

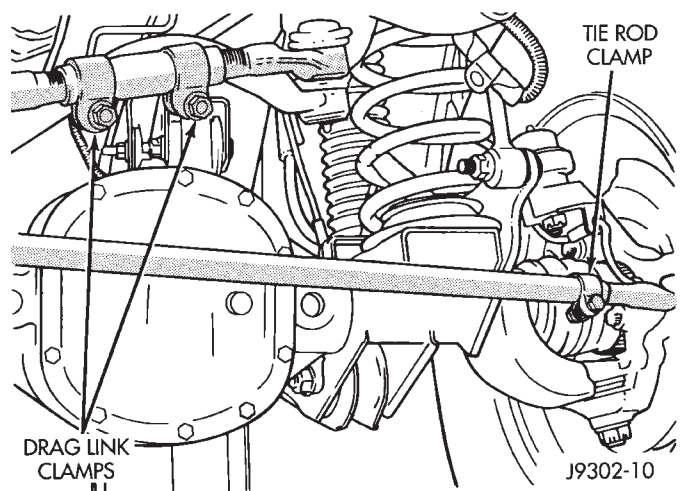


Fig. 3 Drag Link and Tie Rod Clamp

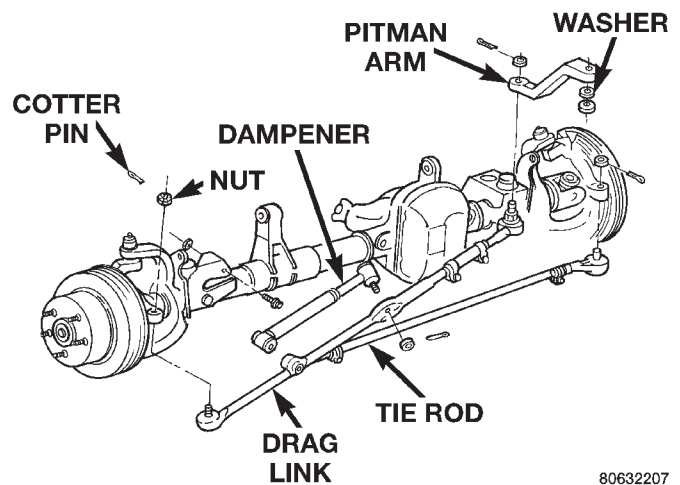
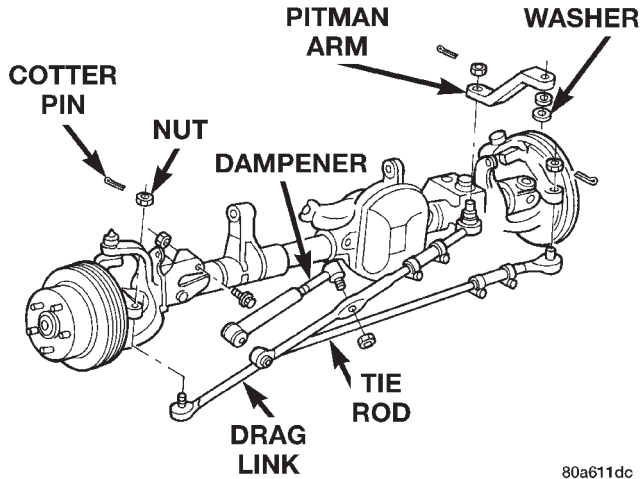


Fig. 4 Steering Linkage - 6 Cylinder Engine

SERVICE PROCEDURES (Continued)



80a611dc

Fig. 5 Steering Linkage – 8 Cylinder Engine

(5) Adjust the left wheel toe position with the tie rod. Turn the sleeve until the left wheel is at the preferred positive TOE-IN specification and the TOE DIFFERENTIAL is within .05°. Position the clamp bolts as shown (Fig. 3) and tighten to:

- Vehicles with 6 cyl engine: 27 N·m (20 ft. lbs.)
- Vehicles with 8 cyl engine: 49 N·m (36 ft. lbs.)

NOTE: Tighten the clamp bolt furthest from the wheel first. Make sure the toe setting does not change during clamp tightening.

(6) Verify alignment specifications, then turn the engine off.

SPECIFICATIONS

ALIGNMENT

FRONT WHEELS

ADJUSTMENT	PREFERRED	RANGE
CASTER	7°	6.5° to 7.5°
CAMBER	NA	- 1.13° to + 0.13°
TOE-IN (each wheel)	0.12°	0° to + 0.22°
Toe Differential Left to Right .05°		

REAR AXLE

ADJUSTMENT	SPECIFICATION
THRUST ANGLE	± .25°
TOTAL TOE-IN	0.00 to + 0.5°

FRONT SUSPENSION

INDEX

	page		page
DESCRIPTION AND OPERATION		STABILIZER BAR	10
FRONT SUSPENSION	6	STEERING KNUCKLE	8
DIAGNOSIS AND TESTING		TRACK BAR	11
SHOCK DIAGNOSIS	7	UPPER SUSPENSION ARM	9
REMOVAL AND INSTALLATION		WHEEL MOUNTING STUDS	12
AXLE BUSHING	9	SPECIFICATIONS	
COIL SPRING	8	TORQUE CHART	12
HUB BEARING	11	SPECIAL TOOLS	
LOWER SUSPENSION ARM	8	FRONT SUSPENSION	13
SHOCK ABSORBER	8		

DESCRIPTION AND OPERATION

FRONT SUSPENSION

The Grand Cherokee front suspension is a link/coil design comprised of (Fig. 1):

- Drive axle (4WD), tube axle (2WD)
- Dual-action shock absorbers
- Coil springs
- Upper and lower suspension arms

- Stabilizer bar
- Track bar
- Jounce bumpers

Link/Coil Suspension: The link/coil suspension allows each wheel to adapt to different road surfaces without greatly affecting the opposite wheel. Wheels are attached to a hub/bearings which bolts to the knuckles. The hub/bearing is not serviceable and is replaced as a unit. Steering knuckles pivot on

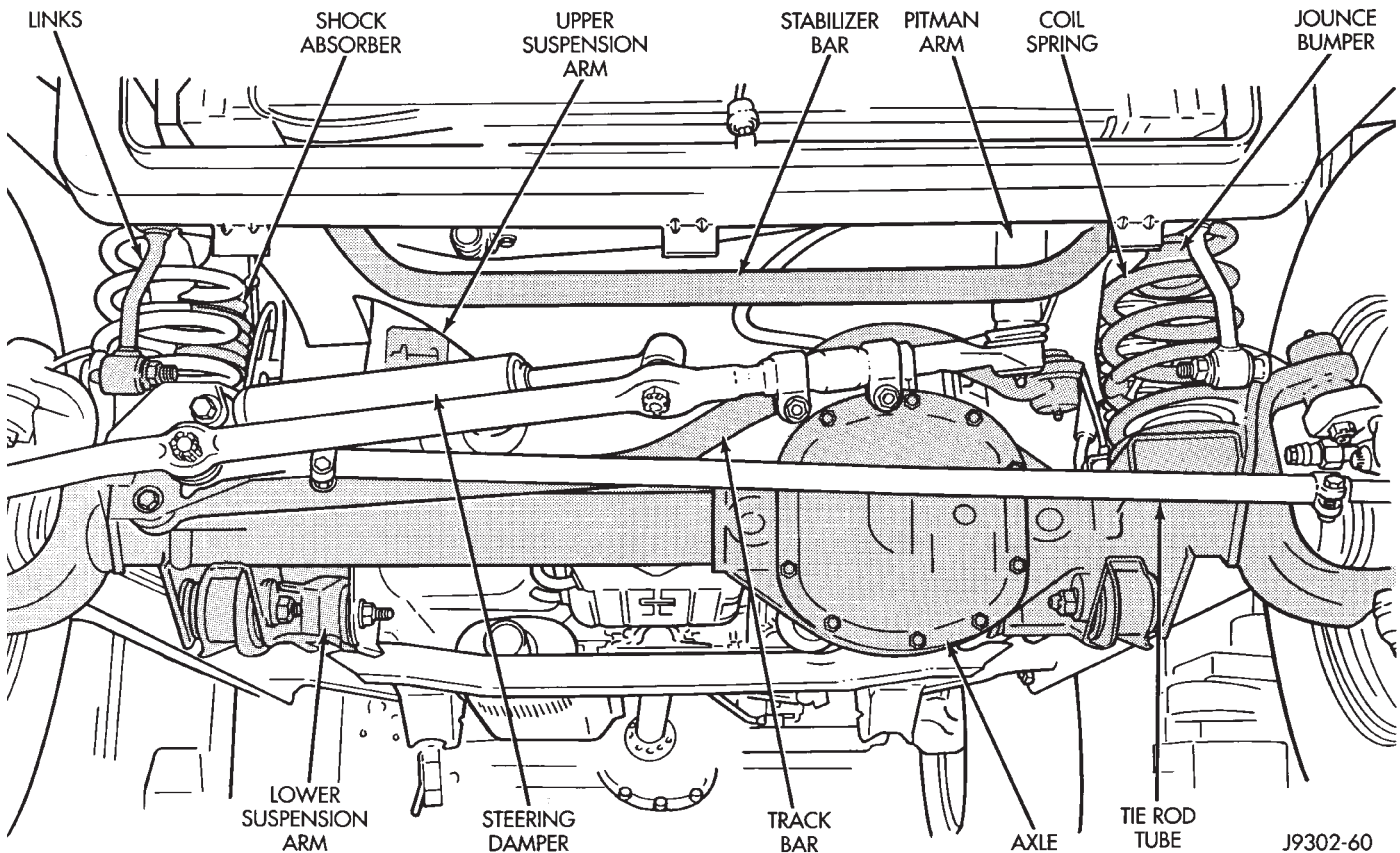


Fig. 1 Front Suspension

DESCRIPTION AND OPERATION (Continued)

replaceable ball studs attached to the axle tube yokes.

Shock Absorbers: The shock absorbers dampen jounce and rebound motion of the vehicle over various road conditions. The top of the shock absorbers are bolted to the body. The bottom of the shocks are bolted to the axle brackets.

Coil Springs: The coil springs control ride quality and maintain proper ride height. The coil springs mount up in the wheelhouse which is part of the unitized body bracket. A rubber doughnut isolator is located between the top of the spring and the body. The bottom of the spring seats on a axle pad and is retained with a clip.

Upper And Lower Suspension Arms: The suspension arms use bushings to isolate road noise. The suspension arms are bolted to the frame and axle through the rubber bushings. The lower suspension arm uses cam bolts at the axle to allow for caster and pinion angle adjustment. The suspension arm travel is limited through the use of jounce bumpers in compression and shocks absorbers in rebound.

Stabilizer Bar: The stabilizer bar is used to control vehicle body roll during turns. The spring steel bar helps to control the vehicle body in relationship to the suspension. The bar extends across the front underside of the chassis and connects to the frame rails. Links are connected from the bar to the axle brackets. Stabilizer bar mounts are isolated by rubber bushings.

Track Bar: The track bar is used to control front axle lateral movement. The bar is attached to a frame rail bracket with a ball stud and isolated with a bushing at the axle bracket.

CAUTION: Components attached with a nut and cotter pin must be torqued to specification. Then if the slot in the nut does not line up with the cotter pin hole, tighten nut until it is aligned. Never loosen the nut to align the cotter pin hole.

CAUTION: Suspension components with rubber/urethane bushings (except stabilizer bar) should be tightened with the vehicle at normal ride height. It is important to have the springs supporting the weight of the vehicle when the fasteners are torqued. If springs are not at their normal ride position, vehicle ride comfort could be affected and premature bushing wear may occur.

NOTE: Periodic lubrication of the front suspension/steering system components may be required. Rubber bushings must never be lubricated. Refer to Group 0, Lubrication And Maintenance for the recommended maintenance schedule.

DIAGNOSIS AND TESTING

SHOCK DIAGNOSIS

A knocking or rattling noise from a shock absorber may be caused by movement between mounting bushings and metal brackets or attaching components. These noises can usually be stopped by tightening the attaching nuts. If the noise persists, inspect for damaged and worn bushings, and attaching components. Repair as necessary if any of these conditions exist.

A squeaking noise from the shock absorber may be caused by the hydraulic valving and may be intermittent. This condition is not repairable and the shock absorber must be replaced.

The shock absorbers are not refillable or adjustable. If a malfunction occurs, the shock absorber must be replaced. To test a shock absorber, hold it in an upright position and force the piston in and out of the cylinder four or five times. The action throughout each stroke should be smooth and even.

The shock absorber bushings do not require any type of lubrication. Do not attempt to stop bushing noise by lubricating them. Grease and mineral oil-base lubricants will deteriorate the bushing.

REMOVAL AND INSTALLATION

SHOCK ABSORBER

REMOVAL

(1) Remove the nut, retainer and grommet from the upper stud in the engine compartment (Fig. 2).

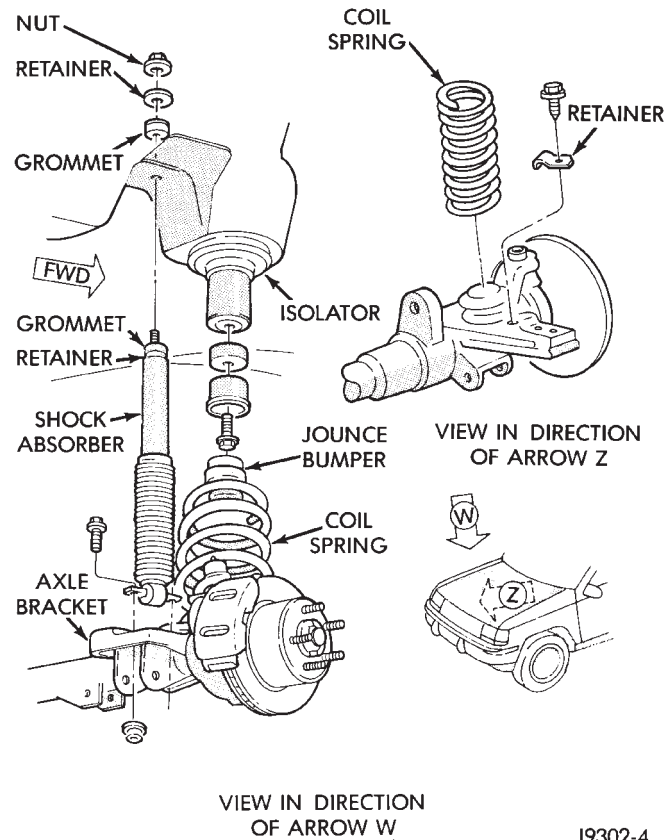


Fig. 2 Coil Spring & Shock Absorber

(2) Remove the lower nuts and bolts from the axle bracket. Remove the shock absorber.

INSTALLATION

(1) Position the lower retainer and grommet on the upper stud. Insert the shock absorber through the shock tower hole.

(2) Install the lower bolts and nuts. Tighten nuts to 28 N·m (250 in. lbs.).

(3) Install the upper grommet and retainer on the stud in the engine compartment. Install the nut and tighten to 23 N·m (17 ft. lbs.).

COIL SPRING

REMOVAL

(1) Raise and support the vehicle. Position a hydraulic jack under the axle to support it.

(2) Remove rear lower suspension arm bolts.

(3) Remove caliper flex hose brackets from the frame rails.

(4) Remove ABS sensor wires from brackets.

(5) Disconnect the stabilizer bar link and shock absorber from the axle.

(6) Disconnect the track bar from the frame rail bracket.

(7) Disconnect the drag link from the pitman arm.

(8) Lower the axle until the spring is free from the upper mount. Remove the coil spring retainer bolt (Fig. 2) and remove the spring.

(9) Remove the jounce bumper if necessary from the upper spring mount (Fig. 2).

INSTALLATION

(1) Install the jounce bumper on the upper spring mount.

(2) Position the coil spring on the axle pad. Install the spring retainer and bolt.

(3) Raise the axle into position until the spring seats in the upper mount.

(4) Install lower suspension arms and rear bolts.

(5) Install caliper flex hose brackets to the frame rails.

(6) Install ABS sensor wires into brackets.

(7) Connect the stabilizer bar links and shock absorbers to the axle bracket. Connect the track bar to the frame rail bracket.

(8) Install drag link to pitman arm.

(9) Remove the supports and lower the vehicle.

(10) Tighten all suspension components to proper torque.

STEERING KNUCKLE

For service procedures on the steering knuckle and ball joints refer to Group 3 Differentials And Driveline.

LOWER SUSPENSION ARM

REMOVAL

(1) Raise and support the vehicle.

(2) Paint or scribe alignment marks on the cam adjusters and suspension arm for installation reference (Fig. 3).

(3) Remove the lower suspension arm nut, cam and cam bolt from the axle (Fig. 4).

(4) Remove the nut and bolt from the frame rail bracket and remove the lower suspension arm (Fig. 4).

INSTALLATION

(1) Position the lower suspension arm at the axle bracket and frame rail bracket.

(2) Install the rear bolts and finger tighten the new nuts.

(3) Install a new cam bolt, cam and new nut in the axle. Re-align the reference marks.

REMOVAL AND INSTALLATION (Continued)

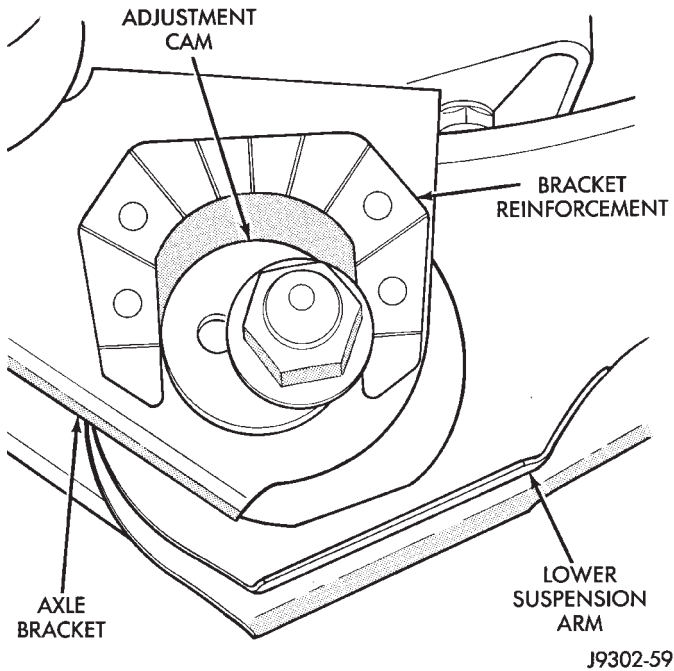


Fig. 3 Cam Adjuster

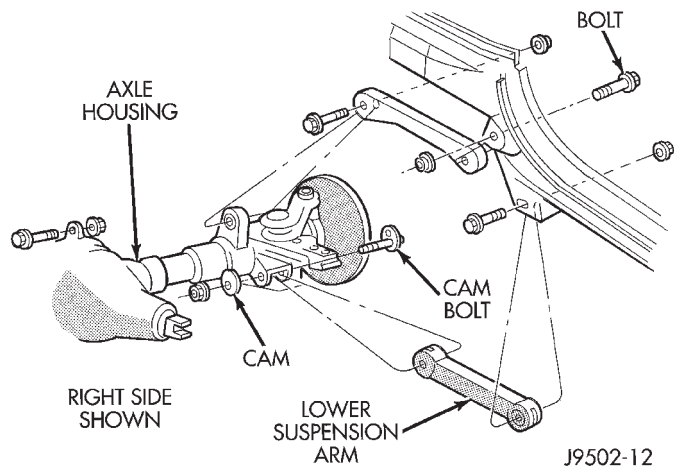


Fig. 4 Upper & Lower Suspension Arms

- (4) Install the bolts and finger tighten the new nuts.
- (5) Lower the vehicle.
- (6) Tighten the axle bracket nut to 115 N·m (85 ft. lbs.).
- (7) Tighten the frame bracket nut to 176 N·m (130 ft. lbs.).
- (8) Check the alignment if new parts were installed.

UPPER SUSPENSION ARM

REMOVAL

- (1) Raise and support the vehicle.
- (2) Remove the upper suspension arm nut and bolt at the axle bracket (Fig. 4).
- (3) Remove the nut and bolt at the frame rail and remove the upper suspension arm.

INSTALLATION

- (1) Position the upper suspension arm at the axle and frame rail.
- (2) Install the bolts and finger tighten the nuts.
- (3) Remove the supports and lower the vehicle.
- (4) Tighten the nut at the axle and frame bracket to 75 N·m (55 ft. lbs.).

AXLE BUSHING

REMOVAL

- (1) Remove the upper suspension arm from axle.
- (2) Position spacer 7932-1 (J-35581-1) over the bushing in the axle for two-wheel drive axles and right side on Model 30 axle.
- (3) Install Bushing Removal/Installer (Fig. 5).
- (4) Remove the bushing by tightening the Long Nut.

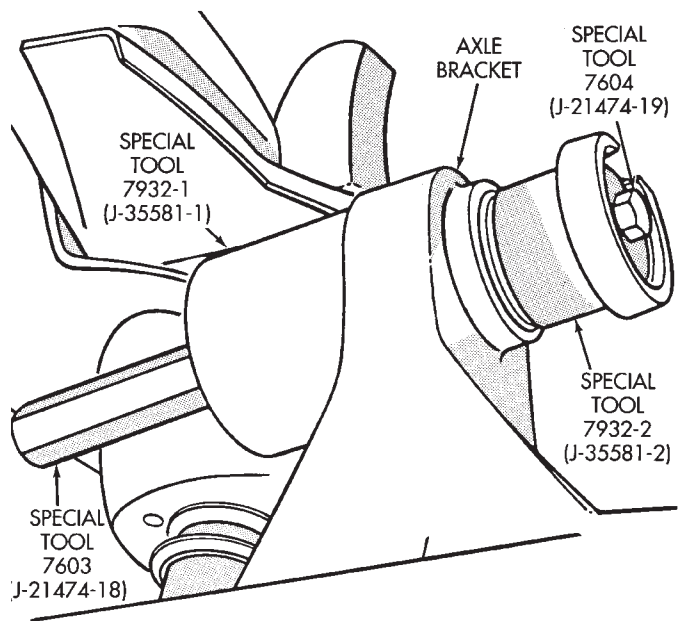
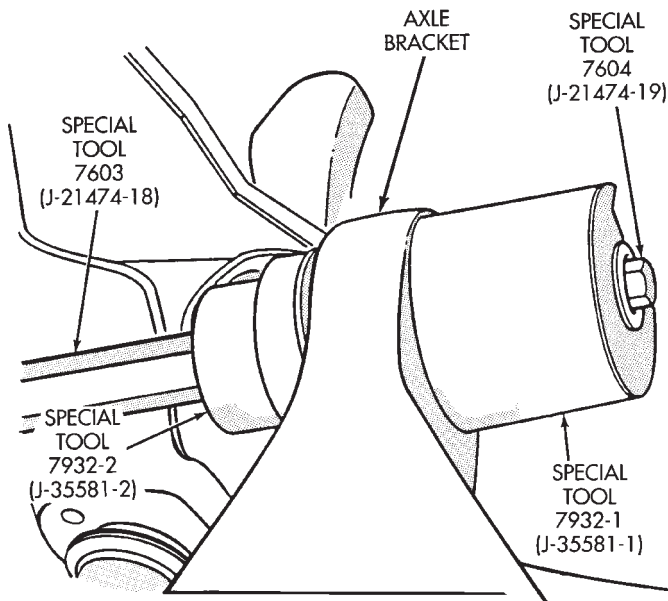


Fig. 5 Bushing Removal

NOTE: For two-wheel drive axles and right side on Model 30 axle, do not remove spacer 7932-1 (J-35581-1). This spacer is need for installation.

REMOVAL AND INSTALLATION (Continued)**INSTALLATION**

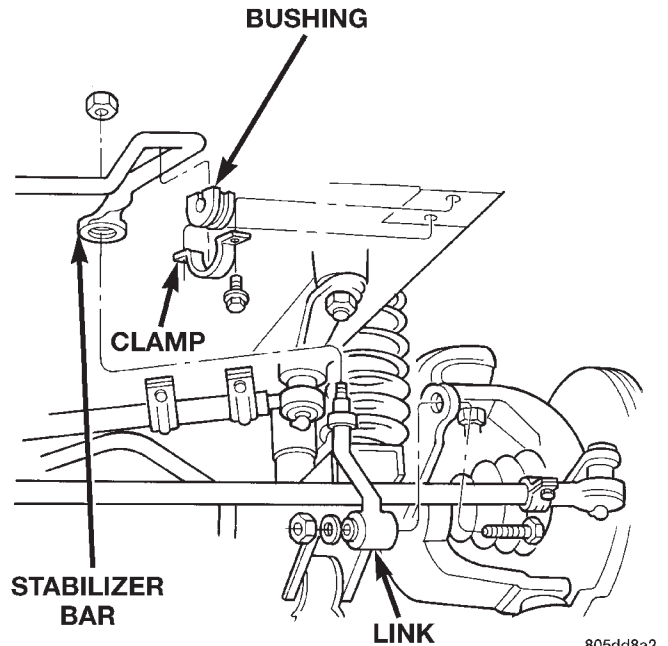
- (1) Position new bushing, Receiver and Installer on axle (Fig. 6).
- (2) Install the bushing by tightening the Long Nut.

**Fig. 6 Bushing Installation**

- (3) Remove tools and install the upper suspension arm.

STABILIZER BAR**REMOVAL**

- (1) Raise and support the vehicle.
- (2) Remove upper link nuts (Fig. 7) and separate links from the stabilizer bar with Remover MB-990635.
- (3) Remove the stabilizer bar clamps bolts from the frame rails and remove the stabilizer bar.
- (4) Remove the stabilizer bar link nuts from the axle brackets (Fig. 7).

**Fig. 7 Stabilizer Bar****INSTALLATION**

- (1) Position the stabilizer bar on the frame rail and install the clamps and bolts. Ensure the bar is centered with equal spacing on both sides. Tighten the bolts to 54 N·m (40 ft. lbs.).
- (2) Install the links into the stabilizer bar and axle brackets.
- (3) Tighten the nuts at the axle bracket end to 95 N·m (70 ft. lbs.).
- (4) Tighten the stabilizer bar to link nuts to 61 N·m (45 ft. lbs.).
- (5) Remove the supports and lower the vehicle.
- (6) Tighten the nuts at the axle bracket end to 95 N·m (70 ft. lbs.).

REMOVAL AND INSTALLATION (Continued)**TRACK BAR****REMOVAL**

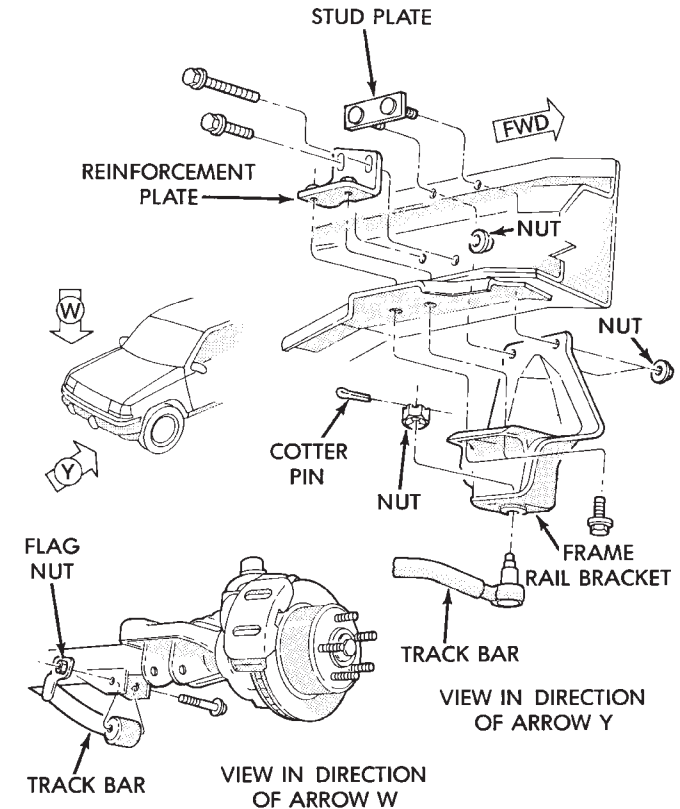
- (1) Raise and support the vehicle.
- (2) Remove the cotter pin and nut from the ball stud end at the frame rail bracket (Fig. 8).
- (3) Use a universal puller to separate the ball stud from the frame rail bracket.
- (4) Remove the bolt and flag nut from the axle shaft tube bracket (Fig. 8). Remove the track bar.

INSTALLATION

- (1) Install the track bar at axle tube bracket. Loosely install the retaining bolt and flag nut.
- (2) It may be necessary to pry the axle assembly over to install the track bar at the frame rail. Install track bar at the frame rail bracket. Install the retaining nut on the stud.
- (3) Tighten the ball stud nut to 81 N·m (60 ft. lbs.). Install a new cotter pin.
- (4) Remove the supports and lower the vehicle.
- (5) Tighten the bolt at the axle shaft tube bracket to 75 N·m (55 ft. lbs.).
- (6) Check alignment if a new track bar was installed.

HUB BEARING**REMOVAL**

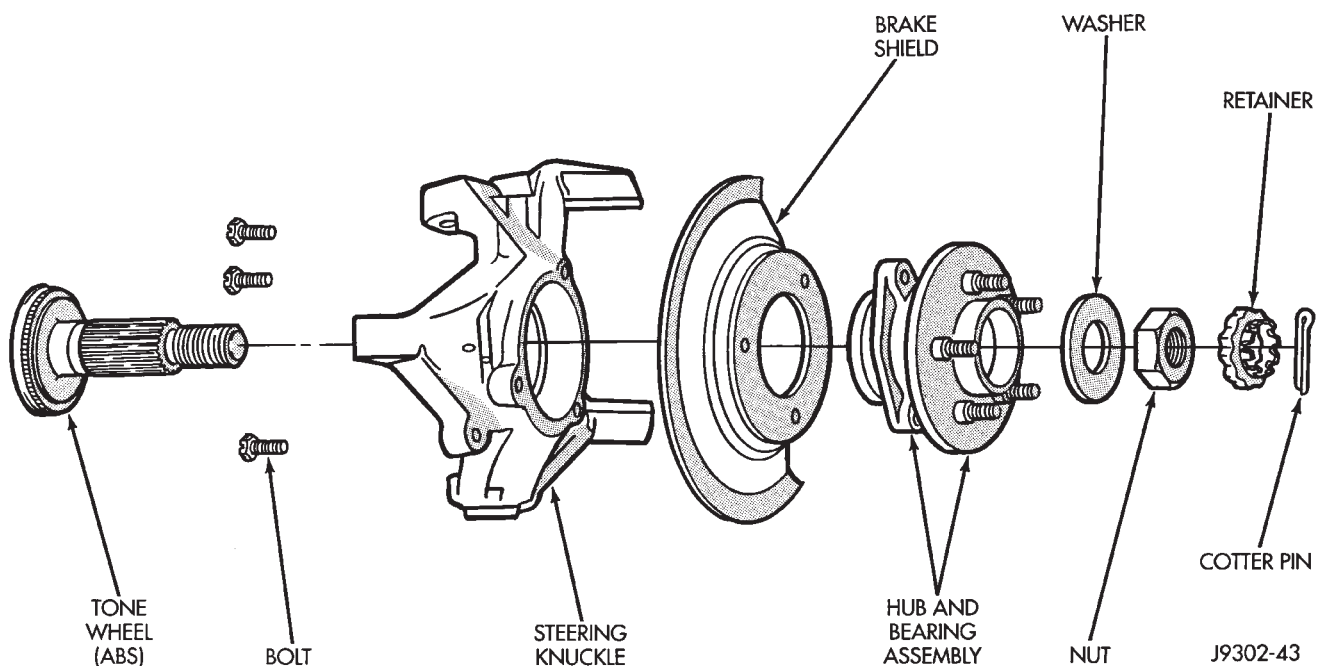
- (1) Raise and support the vehicle.
- (2) Remove the wheel and tire assembly.
- (3) Remove the brake caliper, rotor and ABS wheel speed sensor, refer to Group 5 Brakes.



J9302-1

Fig. 8 Track Bar

- (4) Remove the cotter pin, nut retainer and axle hub nut (Fig. 9).
- (5) Remove the hub mounting bolts and remove hub bearing from the steering knuckle and axle shaft.



J9302-43

Fig. 9 Hub Bearing & Knuckle

REMOVAL AND INSTALLATION (Continued)

INSTALLATION

- (1) Install the hub bearing and brake dust shield to the knuckle.
- (2) Install the hub to knuckle bolts and tighten to 102 N·m (75 ft. lbs.).
- (3) Install the hub washer and nut. Tighten the hub nut to 237 N·m (175 ft. lbs.). Install the nut retainer and a new cotter pin.
- (4) Install the brake rotor, caliper and ABS wheel speed sensor, refer to Group 5 Brakes.
- (5) Install the wheel and tire assembly.
- (6) Remove support and lower the vehicle.

WHEEL MOUNTING STUDS

REMOVAL

- (1) Raise and support vehicle.
- (2) Remove wheel and tire assembly.
- (3) Remove brake caliper and rotor, refer to Group 5 Brakes for procedure.
- (4) Remove stud from hub with Remover C-4150A (Fig. 10).

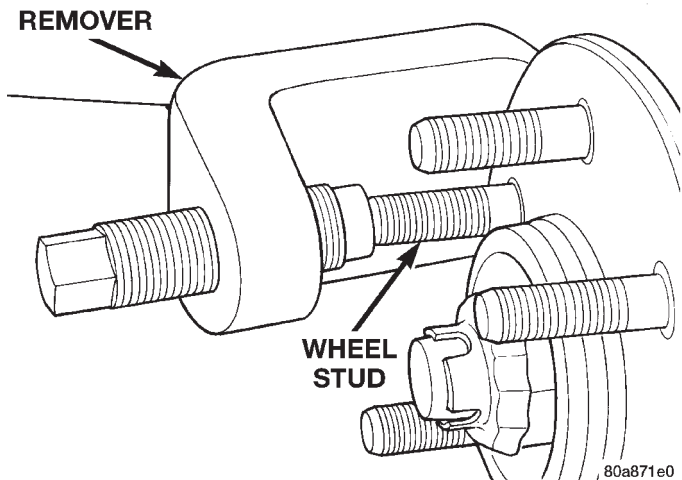


Fig. 10 Wheel Stud Removal

INSTALLATION

- (1) Install new stud into hub flange.
- (2) Install three washers onto stud, then install lug nut with the flat side of the nut against the washers.
- (3) Tighten lug nut until the stud is pulled into the hub flange. Verify that the stud is properly seated into the flange.
- (4) Remove lug nut and washers.
- (5) Install the brake rotor and caliper, refer to Group 5 Brakes for procedure.
- (6) Install wheel and tire assembly, use new lug nut on stud or studs that were replaced.
- (7) Remove support and lower vehicle.

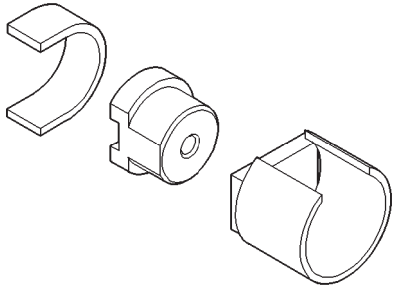
SPECIFICATIONS

TORQUE CHART

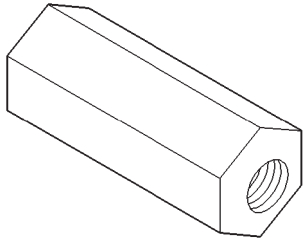
DESCRIPTION	TORQUE
Shock Absorber	
Upper Nut23 N·m (17 ft. lbs.)
Lower Nut28 N·m (250 in. lbs.)
Suspension Arm Upper	
Nuts75 N·m (55 ft. lbs.)
Suspension Arm Lower	
Axle Bracket Nut115 N·m (85 ft. lbs.)
Frame Bracket Nut176 N·m (130 ft. lbs.)
Stabilizer Bar	
Clamp Bolt54 N·m (40 ft. lbs.)
Link Upper Nut61 N·m (45 ft. lbs.)
Link Lower Bolt95 N·m (70 ft. lbs.)
Track Bar	
Ball Stud Nut81 N·m (60 ft. lbs.)
Axle Bracket Bolt75 N·m (55 ft. lbs.)
Track Bar Bracket	
Bolts121 N·m (90 ft. lbs.)
Nut121 N·m (90 ft. lbs.)
Support Bolts95 N·m (70 ft. lbs.)
Hub Bearing	
Bolts102 N·m (75 ft. lbs.)

SPECIAL TOOLS

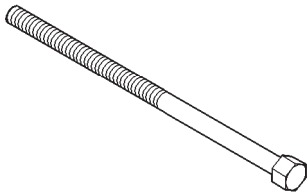
FRONT SUSPENSION



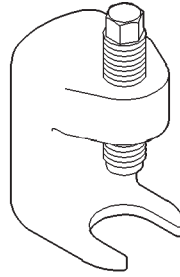
**Remover/Installer Suspension Bushing 7932
(J-35581)**



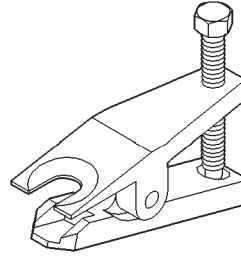
Nut, Long 7603 (J-21474-18)



Bolt, Special 7604 (J-21474-19)



Remover C-4150A



8011d8e6

Remover Tie Rod End MB-990635

REAR SUSPENSION

INDEX

	page		page
DESCRIPTION AND OPERATION		SHOCK ABSORBER	15
REAR SUSPENSION	14	STABILIZER BAR	16
DIAGNOSIS AND TESTING		TRACK BAR	17
SHOCK DIAGNOSIS	15	UPPER SUSPENSION ARM	16
REMOVAL AND INSTALLATION		SPECIFICATIONS	
COIL SPRING	15	TORQUE CHART	17
LOWER SUSPENSION ARM	16		

DESCRIPTION AND OPERATION

REAR SUSPENSION

The rear suspension is link/coil design comprised of (Fig. 1):

- Drive axle
- Dual-action shock absorbers
- Coil springs
- Upper and lower suspension arms
- Track bar
- Stabilizer bar

Upper And Lower Suspension: The suspension arms use bushings to isolate road noise. The suspension arms are bolted to the body and axle through the rubber bushings. The lower suspension arm has provision for the use of cam bolts at the axle to allow for pinion angle or thrust angle adjustment. The cams are available as a service kit and are not installed at the factory. The suspension arm travel is limited through the use of jounce bumpers in compression and shock absorbers in rebound.

Shock Absorbers: The shock absorbers dampen jounce and rebound of the vehicle over various road conditions. The top of the shock absorbers are bolted to the body. The bottom of the shocks are bolted to the axle shock absorber bracket.

Coil Springs: The coil springs mount up in the fender shield that is part of the unitized body bracket. There is a rubber isolator between the top of the spring and bracket to isolate road noise. The bottom of the spring seats on the axle pad and is retained with a clip.

Stabilizer Bar: The stabilizer bar is used to control vehicle body roll during turns. The spring steel bar helps to equalize the vehicle body in relationship to the suspension. The bar extends across the underside of the chassis and connects to the frame rails. Links are connected from the bar to the axle brackets. Stabilizer bar are isolated by rubber bushings.

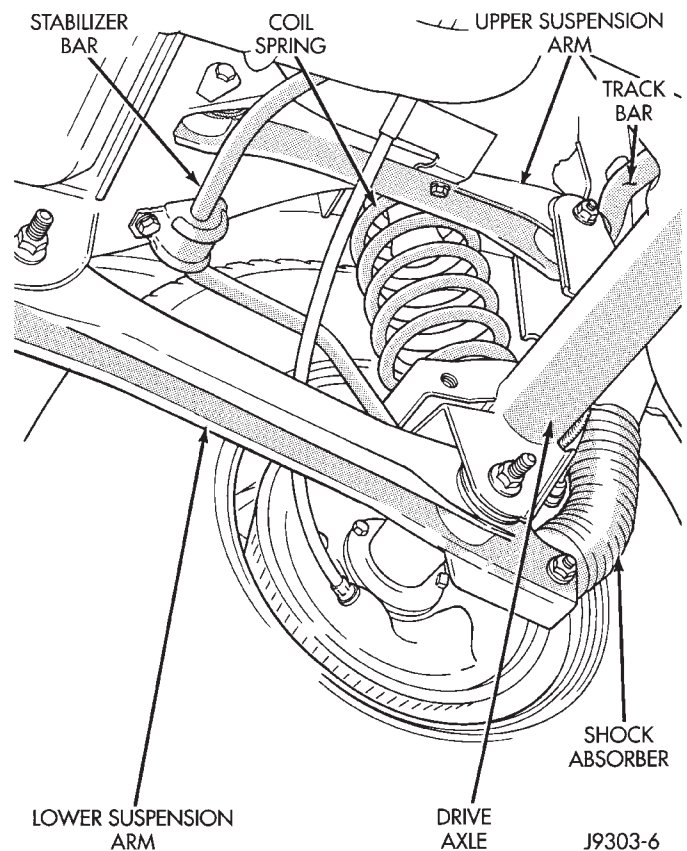


Fig. 1 Rear Suspension

Track Bar: The track bar is used to control rear axle lateral movement. The track bar is attached to a frame rail bracket and an axle bracket. It is isolated with bushings at both ends.

CAUTION: Suspension components with rubber/urethane bushings (except stabilizer bar) should be tightened with the vehicle at normal ride height. It is important to have the springs supporting the weight of the vehicle when the fasteners are torqued. This will maintain vehicle ride comfort and prevent premature bushing wear.

DIAGNOSIS AND TESTING

SHOCK DIAGNOSIS

A knocking or rattling noise from a shock absorber may be caused by movement between mounting bushings and metal brackets or attaching components. These noises can usually be stopped by tightening the attaching nuts. If the noise persists, inspect for damaged and worn bushings, and attaching components. Repair as necessary if any of these conditions exist.

A squeaking noise from the shock absorber may be caused by the hydraulic valving and may be intermittent. This condition is not repairable and the shock absorber must be replaced.

The shock absorbers are not refillable or adjustable. If a malfunction occurs, the shock absorber must be replaced. To test a shock absorber, hold it in an upright position and force the piston in and out of the cylinder four or five times. The action throughout each stroke should be smooth and even.

The shock absorber bushings do not require any type of lubrication. Do not attempt to stop bushing noise by lubricating them. Grease and mineral oil-base lubricants will deteriorate the bushing.

REMOVAL AND INSTALLATION

SHOCK ABSORBER

REMOVAL

- (1) Raise and support the vehicle. Position a hydraulic jack under the axle to support it.
- (2) Remove the upper nut and retainer from the frame rail stud (Fig. 2).
- (3) Remove the lower nut and bolt from the axle bracket. Remove the shock absorber.

INSTALLATION

- (1) Install the shock absorber on the upper frame rail stud. Install the shock absorber on the axle bracket.
- (2) Install the retainer and nut on the stud. Tighten the upper nut to 70 N·m (52 ft. lbs.).
- (3) Install lower bolt and nut finger tight.
- (4) Remove the supports and lower the vehicle.
- (5) Tighten the lower nut to 92 N·m (68 ft. lbs.).

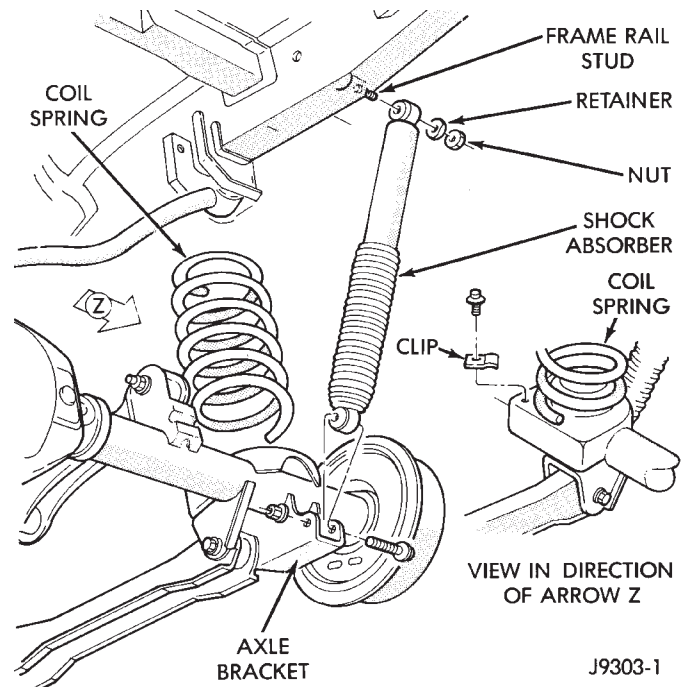


Fig. 2 Rear Coil Spring & Shock Absorber

COIL SPRING

REMOVAL

- (1) Raise and support the vehicle. Position a hydraulic jack under the axle to support it.
- (2) Disconnect the stabilizer bar link and shock absorber from the axle bracket.
- (3) Disconnect the track bar from the frame rail bracket.
- (4) Lower the axle until the spring is free from the upper mount seat. Remove the coil spring retainer bolt (Fig. 2) and remove the spring.

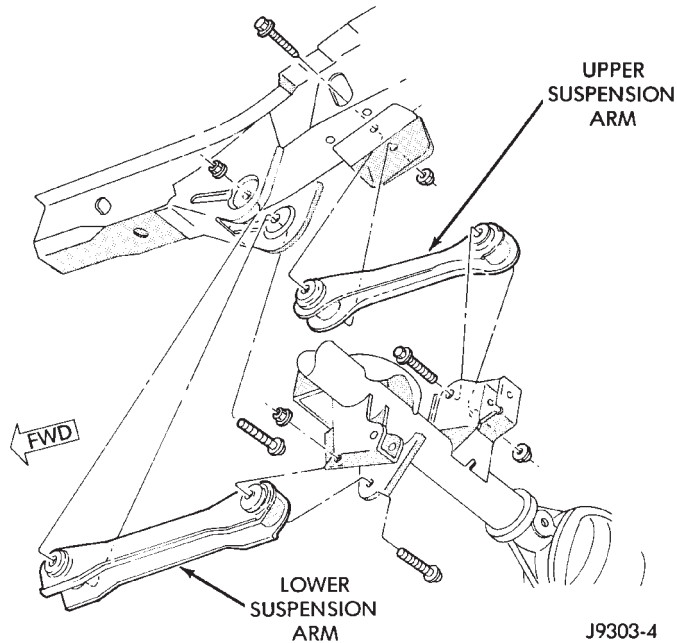
INSTALLATION

Inspect isolator for damage or wear. Replace the isolator if necessary before installing spring.

- (1) Position the coil spring on the axle pad. Install the spring retainer and bolt. Tighten the bolt to 22 N·m (16 ft. lbs.).
- (2) Raise the axle into position until the spring seats in the upper mount.
- (3) Connect the stabilizer bar links and shock absorbers to the axle bracket. Connect the track bar to the frame rail bracket.
- (4) Remove the supports and lower the vehicle.
- (5) Tighten the track bar and shock absorber to specified torque.

REMOVAL AND INSTALLATION (Continued)**LOWER SUSPENSION ARM****REMOVAL**

- (1) Raise and support the vehicle.
- (2) Remove the lower suspension arm nut and bolt at the axle bracket (Fig. 3).
- (3) Remove the nut and bolt (Fig. 3) at the frame rail and remove the lower suspension arm.

**Fig. 3 Upper & Lower Suspension Arms****INSTALLATION**

- (1) Position the lower suspension arm at the axle bracket and frame rail bracket.
- (2) Install the bolts and finger tighten the nuts.
- (3) Remove the supports and lower the vehicle.
- (4) Tighten the lower suspension arm nuts to 177 N-m (130 ft. lbs.).

UPPER SUSPENSION ARM**REMOVAL**

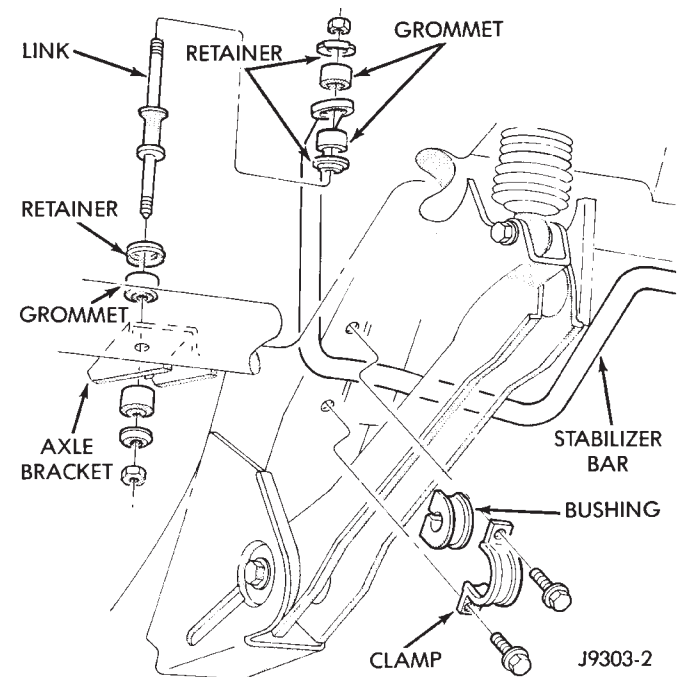
- (1) Raise and support the vehicle.
- (2) Remove the upper suspension arm nut and bolt at the axle bracket (Fig. 3). Remove the ABS wire bracket from the arm.
- (3) Remove the nut and bolt at the frame rail and remove the upper suspension arm.

INSTALLATION

- (1) Position the upper suspension arm at the axle and frame rail.
- (2) Install the bolts and finger tighten the nuts. Install the ABS wire bracket onto the arm.
- (3) Remove the supports and lower the vehicle.
- (4) Tighten the upper suspension arm nuts to 75 N-m (55 ft. lbs.).

STABILIZER BAR**REMOVAL**

- (1) Raise and support the vehicle. Remove one wheel and tire.
- (2) Disconnect the stabilizer bar links from the axle brackets (Fig. 4).
- (3) Lower the exhaust by disconnecting the muffler and tail pipe hangers.
- (4) Disconnect the stabilizer bar from the links.
- (5) Disconnect the stabilizer bar clamps from the frame rails. Remove the stabilizer bar.

**Fig. 4 Rear Stabilizer Bar**

REMOVAL AND INSTALLATION (Continued)

INSTALLATION

- (1) Position the stabilizer bar on the frame rail and install the clamps and bolts. Ensure the bar is centered with equal spacing on both sides. Tighten the bolts to 54 N·m (40 ft. lbs.).
- (2) Install the links and grommets onto the stabilizer bar and axle brackets. Install the nuts and tighten to 36 N·m (27 ft. lbs.).
- (3) Connect the muffler and tail pipe to their hangers.
- (4) Install the wheel and tire assembly.

TRACK BAR

REMOVAL

- (1) Raise and support the vehicle.
- (2) Remove the bolt and nut from the frame rail bracket (Fig. 5).
- (3) Remove the bolt from the axle tube bracket (Fig. 5). Remove the track bar.

INSTALLATION

- (1) Install the track bar to the axle bracket and install a new bolt.
- (2) It may be necessary to pry the axle assembly over to install the track bar. Install the track bar to the frame rail bracket. Loosely install the bolt and flag nut.
- (3) Remove the supports and lower the vehicle.
- (4) Tighten the track bar bolts 100 N·m (74 ft. lbs.).

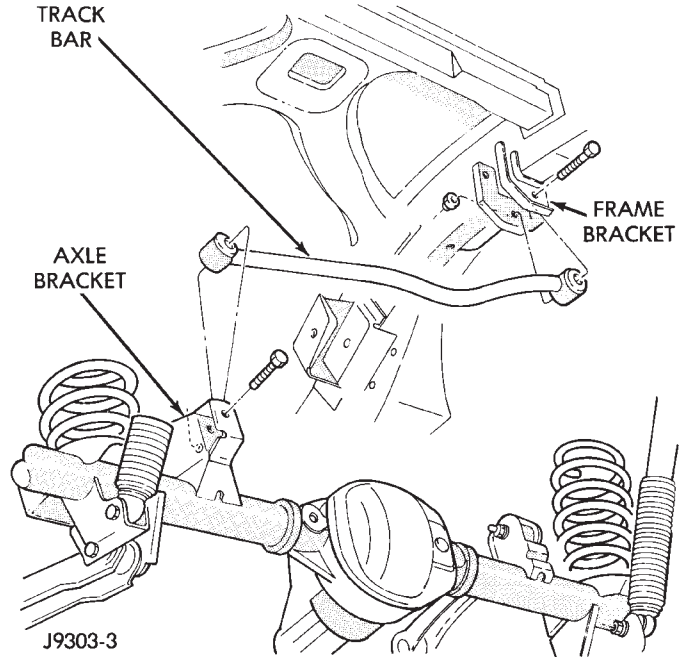


Fig. 5 Rear Track Bar

SPECIFICATIONS

TORQUE CHART

DESCRIPTION	TORQUE
Shock Absorber	
Upper Nut70 N·m (52 ft. lbs.)
Lower Nut92 N·m (68 ft. lbs.)
Suspension Arm Upper	
Nuts75 N·m (55 ft. lbs.)
Suspension Arm Lower	
Nuts177 N·m (130 ft. lbs.)
Stabilizer Bar	
Clamp Bolt54 N·m (40 ft. lbs.)
Link Nut36 N·m (27 ft. lbs.)
Track Bar	
Frame Bracket Nut100 N·m (74 ft. lbs.)
Axle Bracket Bolt100 N·m (74 ft. lbs.)

SUSPENSION

CONTENTS

	page		page
ALIGNMENT	1	REAR SUSPENSION	12
FRONT SUSPENSION	5		

ALIGNMENT

INDEX

	page		page
GENERAL INFORMATION		WHEEL ALIGNMENT	2
WHEEL ALIGNMENT	1	SPECIFICATIONS	
SERVICE PROCEDURES		ALIGNMENT	4
PRE-ALIGNMENT	2		

GENERAL INFORMATION

WHEEL ALIGNMENT

Wheel alignment involves the correct positioning of the wheels in relation to the vehicle. The positioning is accomplished through suspension and steering linkage adjustments. An alignment is considered essential for efficient steering, good directional stability and to minimize tire wear. The most important measurements of an alignment are caster, camber and toe position (Fig. 1).

- **CASTER** is the forward or rearward tilt of the steering knuckle from vertical. Tilting the top of the knuckle rearward provides positive caster. Tilting the top of the knuckle forward provides negative caster. Caster is a directional stability angle. This angle enables the front wheels to return to a straight ahead position after turns.

- **CAMBER** is the inward or outward tilt of the wheel relative to the center of the vehicle. Tilting the top of the wheel inward provides negative camber. Tilting the top of the wheel outward provides positive camber. Incorrect camber will cause wear on the inside or outside edge of the tire. The angle is not adjustable, damaged component(s) must be replaced to correct the camber angle.

- **WHEEL TOE POSITION** is the difference between the leading inside edges and trailing inside edges of the front tires. Incorrect wheel toe position is the most common cause of unstable steering and

uneven tire wear. The wheel toe position is the **final** front wheel alignment adjustment.

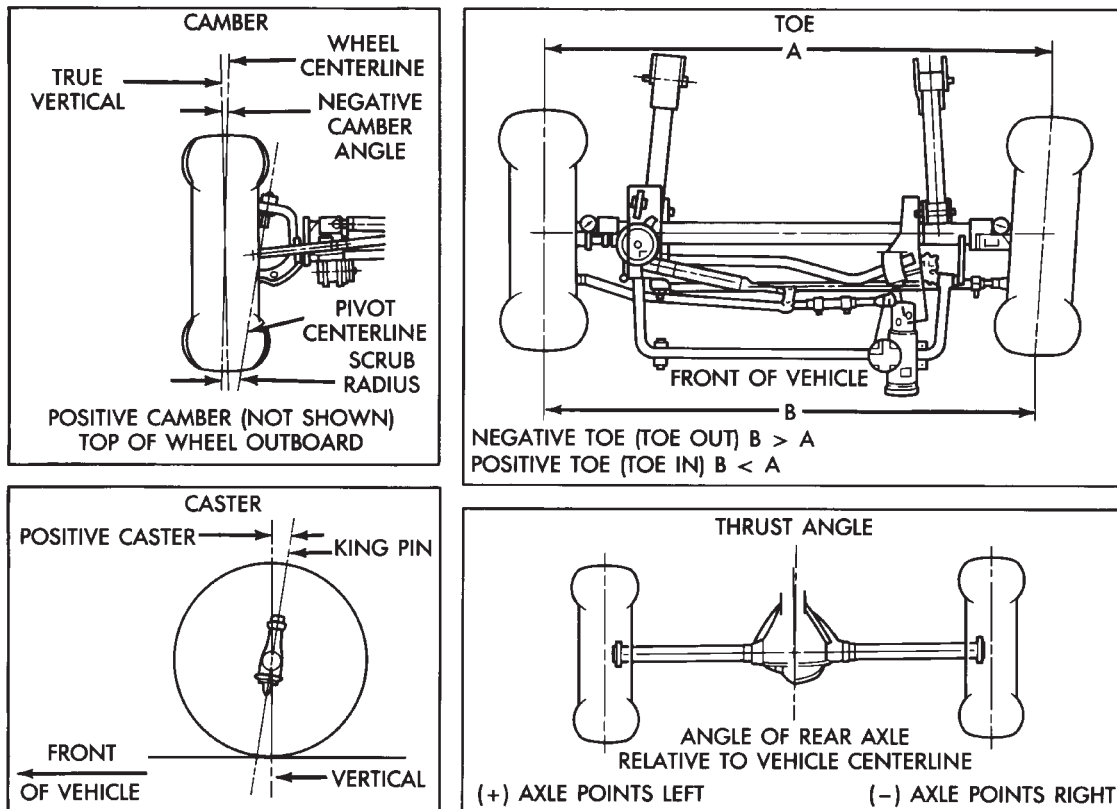
- **STEERING AXIS INCLINATION ANGLE** is measured in degrees and is the angle that the steering knuckles are tilted. The inclination angle has a fixed relationship with the camber angle. It will not change except when a spindle or ball stud is damaged or bent. The angle is not adjustable, damaged component(s) must be replaced to correct the steering axis inclination angle.

- **THRUST ANGLE** is the angle of the rear axle relative to the centerline of the vehicle. Incorrect thrust angle can cause off-center steering and excessive tire wear. This angle is not adjustable, damaged component(s) must be replaced to correct the thrust angle.

CAUTION: Never attempt to modify suspension or steering components by heating or bending.

NOTE: Periodic lubrication of the front suspension/steering system components may be required. Rubber bushings must never be lubricated. Refer to Group 0, Lubrication And Maintenance for the recommended maintenance schedule.

GENERAL INFORMATION (Continued)



J9402-57

Fig. 1 Wheel Alignment Measurements

SERVICE PROCEDURES

PRE-ALIGNMENT

Before starting wheel alignment, the following inspection and necessary corrections must be completed. Refer to Suspension and Steering System Diagnosis Chart for additional information.

- (1) Inspect tires for size, air pressure and tread wear.
- (2) Inspect front wheel bearings for wear.
- (3) Inspect front wheels for excessive radial or lateral runout and balance.
- (4) Inspect ball studs, linkage pivot points and steering gear for looseness, roughness or binding.
- (5) Inspect suspension components for wear and noise.

WHEEL ALIGNMENT

Before each alignment reading the vehicle should be jounced (rear first, then front). Grasp each bumper at the center and jounce the vehicle up and down three times. Always release the bumper in the down position.

CAMBER

The wheel camber angle is preset. This angle is not adjustable and cannot be altered.

CASTER

Check the caster of the front axle for correct angle. Be sure the axle is not bent or twisted. Road test the vehicle and observe the steering wheel return-to-center position. Low caster will cause poor steering wheel returnability.

During the road test, turn the vehicle to both the left and right. If the steering wheel returns to the center position unassisted, the caster angle is correct. However, if steering wheel does not return toward the center position unassisted, a low caster angle is probable.

Caster can be adjusted by loosening and rotating the cams on the lower suspension arm (Fig. 2). **Changing caster angle will also change the front propeller shaft angle. The propeller shaft angle has priority over caster. Refer to Group 3, Differential and Driveline for additional information.**

SERVICE PROCEDURES (Continued)

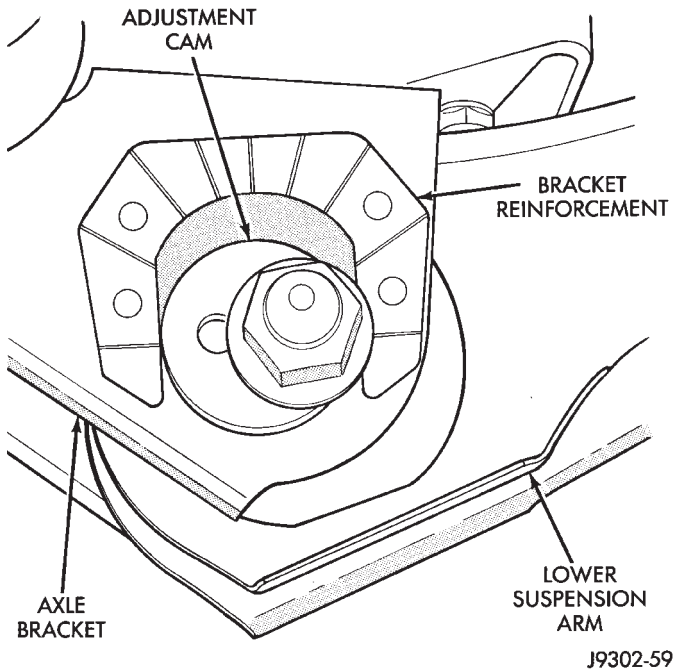


Fig. 2 Cam Adjuster

TOE POSITION (LHD)

NOTE: The wheel toe position adjustment should be the final adjustment.

(1) Start the engine and turn wheels both ways before straightening the steering wheel. Center and secure the steering wheel.

(2) Loosen the adjustment sleeve clamp bolts (Fig. 3).

(3) Adjust the right wheel toe position with the drag link (Fig. 4). Turn the sleeve until the right wheel is at the correct positive TOE-IN position. Position the clamp bolts as shown (Fig. 3) and tighten to:

- Vehicles with 2.5L engine: 27 N·m (20 ft. lbs.)
- Vehicles with 4.0L engine: 27 N·m (20 ft. lbs.)
- Vehicles with 5.2L engine: 49 N·m (36 ft. lbs.)

NOTE: Make sure the toe setting does not change during clamp tightening.

(4) Adjust the left wheel toe position with the tie rod. Turn the sleeve until the left wheel is at the same TOE-IN position as the right wheel. Position the clamp bolts as shown (Fig. 3) and tighten to:

- Vehicles with 2.5L engine: 27 N·m (20 ft. lbs.)
- Vehicles with 4.0L engine: 27 N·m (20 ft. lbs.)
- Vehicles with 5.2L engine: 49 N·m (36 ft. lbs.)

NOTE: Make sure the toe setting does not change during clamp tightening.

(5) Verify the toe setting.

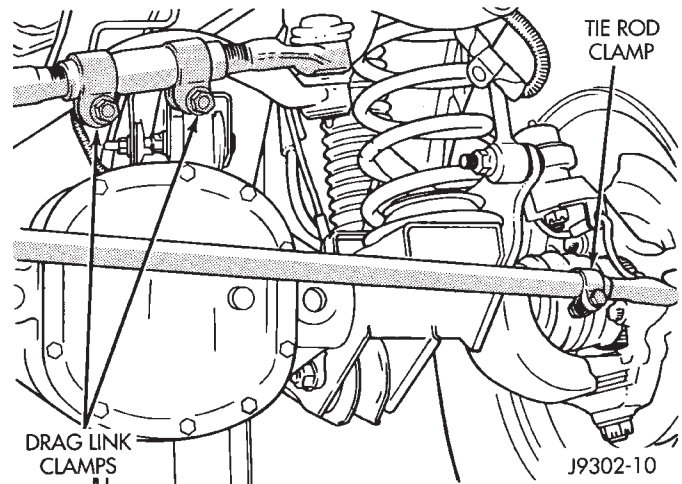


Fig. 3 Drag Link and Tie Rod Clamp (LHD)

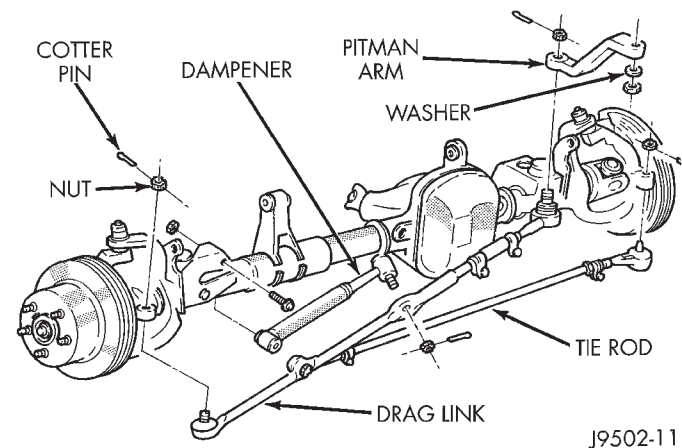


Fig. 4 Steering Linkage (LHD)

TOE POSITION (RHD)

NOTE: The wheel toe position adjustment should be the final adjustment.

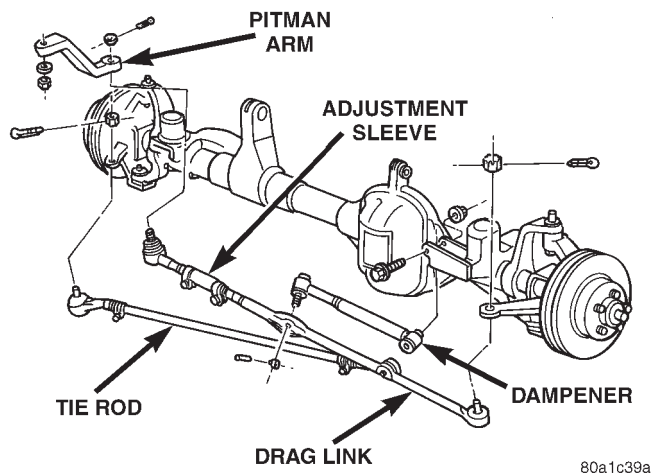
(1) Start the engine and turn wheels both ways before straightening the steering wheel. Center and secure the steering wheel.

(2) Loosen the adjustment sleeve clamp bolts (Fig. 5).

(3) Adjust the left wheel toe position with the drag link (Fig. 5). Turn the sleeve until the left wheel is at the correct positive TOE-IN position. Position the clamp bolts to their original position and tighten to:

- Vehicles with 2.5L engine: 27 N·m (20 ft. lbs.)
- Vehicles with 4.0L engine: 27 N·m (20 ft. lbs.)
- Vehicles with 5.2L engine: 49 N·m (36 ft. lbs.)

NOTE: Make sure the toe setting does not change during clamp tightening.

SERVICE PROCEDURES (Continued)**Fig. 5 Steering Linkage (RHD)**

(4) Adjust the right wheel toe position with the tie rod. Turn the sleeve until the right wheel is at the same TOE-IN position as the left wheel. Position the clamp bolt to its original position and tighten to:

- Vehicles with 2.5L engine: 27 N·m (20 ft. lbs.)
- Vehicles with 4.0L engine: 27 N·m (20 ft. lbs.)
- Vehicles with 5.2L engine: 49 N·m (36 ft. lbs.)

NOTE: Make sure the toe setting does not change during clamp tightening.

(5) Verify the toe setting.

SPECIFICATIONS**ALIGNMENT****FRONT WHEELS**

ADJUSTMENT	PREFERRED	RANGE
CASTER	7°	6.5° to 7.5°
CAMBER	NA	- 1.13° to + 0.13°
TOE-IN (each wheel)	0.12°	0° to + 0.22°
Toe Differential Left to Right .05°		

REAR AXLE

ADJUSTMENT	SPECIFICATION
THRUST ANGLE	± .25°
TOTAL TOE-IN	0.00 to + 0.5°

FRONT SUSPENSION

INDEX

	page		page
DESCRIPTION AND OPERATION		STABILIZER BAR	8
FRONT SUSPENSION	5	STEERING KNUCKLE	7
DIAGNOSIS AND TESTING		TRACK BAR	9
SHOCK DIAGNOSIS	6	UPPER SUSPENSION ARM	8
REMOVAL AND INSTALLATION		WHEEL MOUNTING STUDS	10
AXLE BUSHING	8	SPECIFICATIONS	
COIL SPRING	7	TORQUE CHART	11
HUB BEARING	10	SPECIAL TOOLS	
LOWER SUSPENSION ARM	7	FRONT SUSPENSION	11
SHOCK ABSORBER	6		

DESCRIPTION AND OPERATION

FRONT SUSPENSION

The front suspension is a link/coil design (Fig. 1). This design is used on Left Hand Drive (LHD) and Right Hand Drive (RHD) vehicles. The suspension is comprised of:

- Drive axle (4WD), tube axle (2WD)
- Dual-action shock absorbers
- Coil springs
- Upper and lower suspension arms
- Stabilizer bar
- Track bar
- Jounce Bumper

Link/Coil Suspension: The link/coil suspension allows each wheel to adapt to different road surfaces without greatly affecting the opposite wheel. Wheels are attached to a hub/bearings which bolts to the knuckles. The hub/bearing is not serviceable and is replaced as a unit. Steering knuckles pivot on replaceable ball studs attached to the axle tube yokes.

Shock Absorbers: The shock absorbers dampen jounce and rebound motion of the vehicle over various road conditions. The top of the shock absorbers are bolted to the body. The bottom of the shocks are bolted to the axle brackets.

Coil Springs: The coil springs control ride quality and maintain proper ride height. The coil springs mount up in the wheelhouse which is part of the unitized body bracket. A rubber doughnut isolator is located between the top of the spring and the body. The bottom of the spring seats on a axle pad and is retained with a clip.

Upper And Lower Suspension: The suspension arms use bushings to isolate road noise. The suspension arms are bolted to the frame and axle through the rubber bushings. The lower suspension arm uses

cam bolts at the axle to allow for caster and pinion angle adjustment. The suspension arm travel is limited through the use of jounce bumpers in compression and shocks absorbers in rebound.

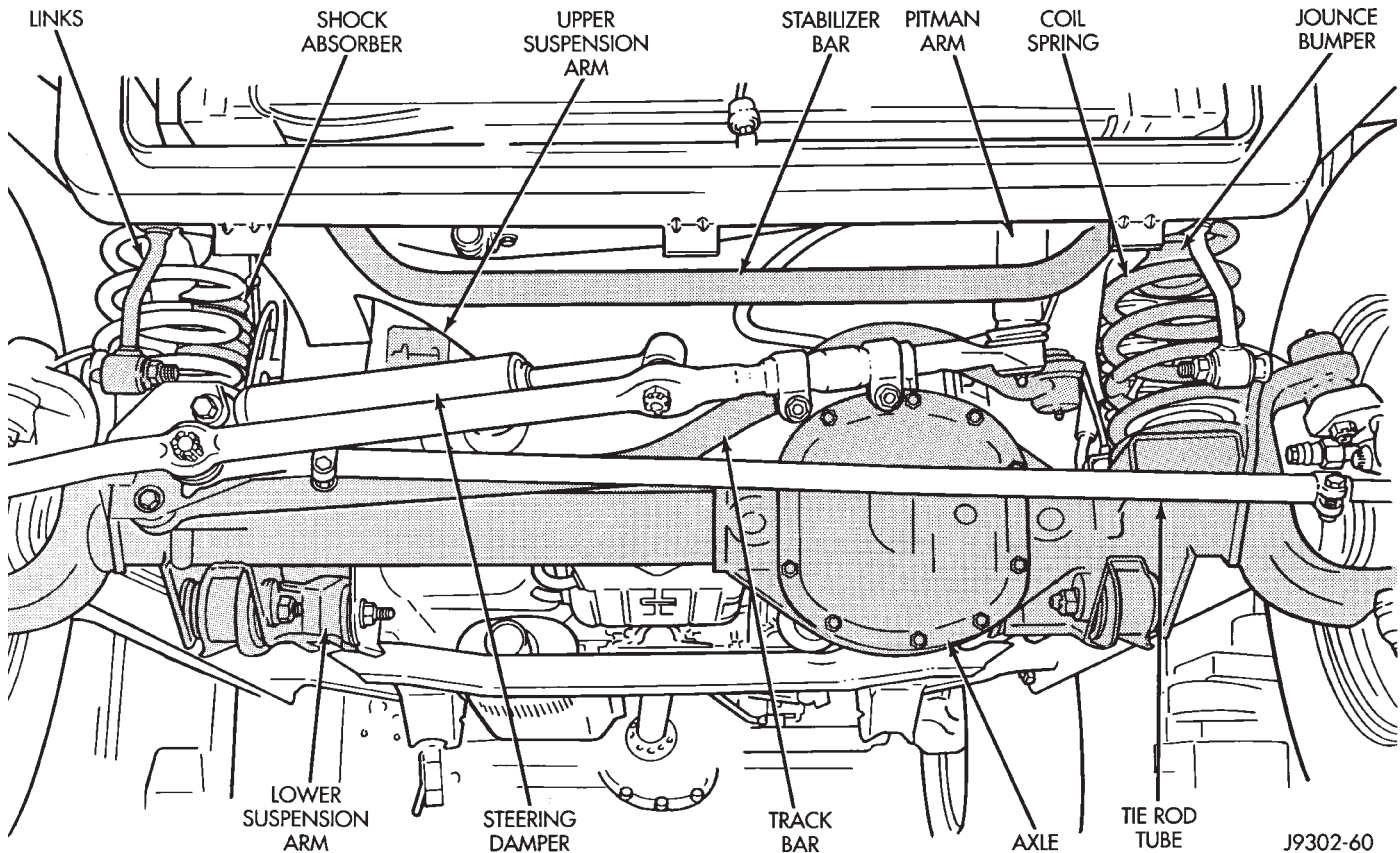
Stabilizer Bar: The stabilizer bar is used to control vehicle body roll during turns. The spring steel bar helps to control the vehicle body in relationship to the suspension. The bar extends across the front underside of the chassis and connects to the frame rails. Links are connected from the bar to the axle brackets. Stabilizer bar mounts are isolated by rubber bushings.

Track Bar: The track bar is used to control front axle lateral movement. The bar is attached to a frame rail bracket with a ball stud and isolated with a bushing at the axle bracket.

CAUTION: Components attached with a nut and cotter pin must be torqued to specification. Then if the slot in the nut does not line up with the cotter pin hole, tighten nut until it is aligned. Never loosen the nut to align the cotter pin hole.

CAUTION: Suspension components with rubber/urethane bushings (except stabilizer bar) should be tightened with the vehicle at normal ride height. It is important to have the springs supporting the weight of the vehicle when the fasteners are torqued. If springs are not at their normal ride position, vehicle ride comfort could be affected and premature bushing wear may occur.

NOTE: Periodic lubrication of the front suspension/steering system components may be required. Rubber bushings must never be lubricated. Refer to Group 0, Lubrication And Maintenance for the recommended maintenance schedule.

DESCRIPTION AND OPERATION (Continued)**Fig. 1 Front Suspension (LHD)**

NOTE: The service procedures and torque specifications are the same for LHD and RHD vehicles. The following service procedures and pictures were developed with a LHD vehicle.

The shock absorber bushings do not require any type of lubrication. Do not attempt to stop bushing noise by lubricating them. Grease and mineral oil-base lubricants will deteriorate the bushing.

DIAGNOSIS AND TESTING**SHOCK DIAGNOSIS**

A knocking or rattling noise from a shock absorber may be caused by movement between mounting bushings and metal brackets or attaching components. These noises can usually be stopped by tightening the attaching nuts. If the noise persists, inspect for damaged and worn bushings, and attaching components. Repair as necessary if any of these conditions exist.

A squeaking noise from the shock absorber may be caused by the hydraulic valving and may be intermittent. This condition is not repairable and the shock absorber must be replaced.

The shock absorbers are not refillable or adjustable. If a malfunction occurs, the shock absorber must be replaced. To test a shock absorber, hold it in an upright position and force the piston in and out of the cylinder four or five times. The action throughout each stroke should be smooth and even.

REMOVAL AND INSTALLATION**SHOCK ABSORBER****REMOVAL**

- (1) Remove the nut, retainer and grommet from the upper stud in the engine compartment (Fig. 2).
- (2) Remove the lower nuts and bolts from the axle bracket. Remove the shock absorber.

INSTALLATION

- (1) Position the lower retainer and grommet on the upper stud. Insert the shock absorber through the shock tower hole.
- (2) Install the lower bolts and nuts. Tighten nuts to 28 N·m (250 in. lbs.).
- (3) Install the upper grommet and retainer on the stud in the engine compartment. Install the nut and tighten to 23 N·m (17 ft. lbs.).

REMOVAL AND INSTALLATION (Continued)

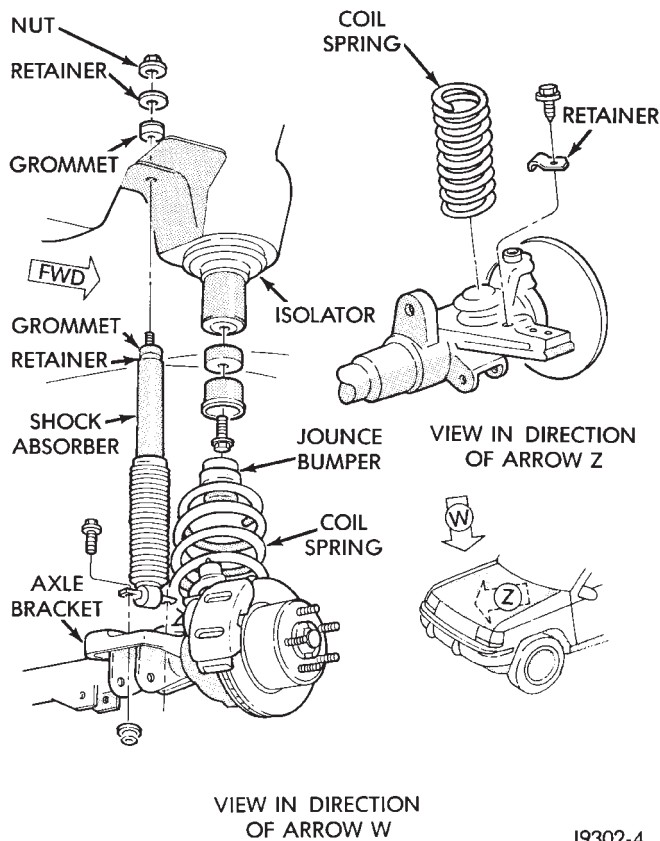


Fig. 2 Coil Spring & Shock Absorber

COIL SPRING

REMOVAL

- (1) Raise and support the vehicle. Position a hydraulic jack under the axle to support it.
- (2) Remove rear lower suspension arm bolts.
- (3) Remove caliper flex hose brackets from the frame rails.
- (4) Remove ABS sensor wires from brackets.
- (5) Disconnect the stabilizer bar link and shock absorber from the axle.
- (6) Disconnect the track bar from the frame rail bracket.
- (7) Disconnect the drag link from the pitman arm.
- (8) Lower the axle until the spring is free from the upper mount. Remove the coil spring retainer bolt (Fig. 2) and remove the spring.
- (9) Remove the jounce bumper if necessary from the upper spring mount (Fig. 2).

INSTALLATION

- (1) Install the jounce bumper on the upper spring mount.
- (2) Position the coil spring on the axle pad. Install the spring retainer and bolt. Tighten bolt to 22 N·m (16 ft lb).

- (3) Raise the axle into position until the spring seats in the upper mount.
- (4) Install lower suspension arms and rear bolts.
- (5) Install caliper flex hose brackets to the frame rails.
- (6) Install ABS sensor wires into brackets.
- (7) Connect the stabilizer bar links and shock absorbers to the axle bracket. Connect the track bar to the frame rail bracket.
- (8) Install drag link to pitman arm.
- (9) Remove the supports and lower the vehicle.
- (10) Tighten all suspension components to proper torque.

STEERING KNUCKLE

For service procedures on the steering knuckle and ball joints refer to Group 3 Differentials And Driveline.

LOWER SUSPENSION ARM

REMOVAL

- (1) Raise and support the vehicle.
- (2) Paint or scribe alignment marks on the cam adjusters and suspension arm for installation reference (Fig. 3).

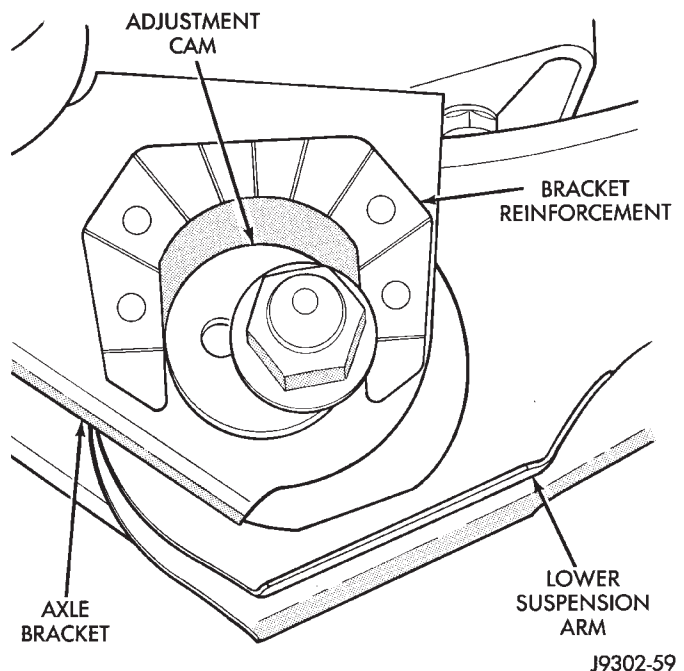
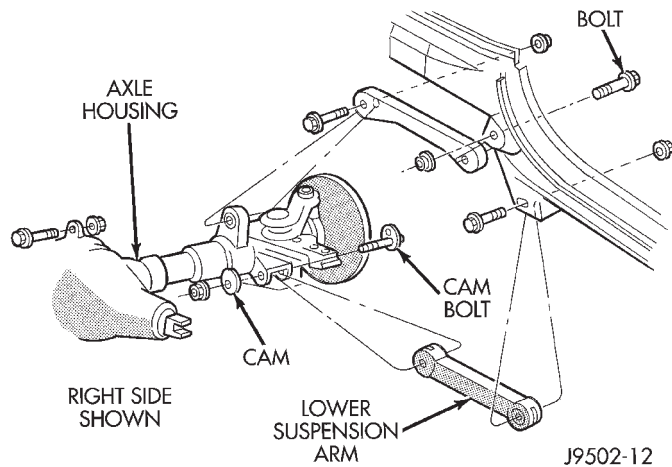


Fig. 3 Cam Adjuster

- (3) Remove the lower suspension arm nut, cam and cam bolt from the axle (Fig. 4).
- (4) Remove the nut and bolt from the frame rail bracket and remove the lower suspension arm (Fig. 4).

REMOVAL AND INSTALLATION (Continued)**Fig. 4 Upper & Lower Suspension Arms****INSTALLATION**

- (1) Position the lower suspension arm at the axle bracket and frame rail bracket.
- (2) Install the rear bolts and finger tighten the new nuts.
- (3) Install a new cam bolt, cam and new nut in the axle. Re-align the reference marks.
- (4) Install the bolts and finger tighten the new nuts.
- (5) Lower the vehicle.
- (6) Tighten the axle bracket nut to 115 N·m (85 ft. lbs.).
- (7) Tighten the frame bracket nut to 176 N·m (130 ft. lbs.).
- (8) Check the alignment if new parts were installed.

UPPER SUSPENSION ARM**REMOVAL**

- (1) Raise and support the vehicle.
- (2) Remove the upper suspension arm nut and bolt at the axle bracket (Fig. 4).
- (3) Remove the nut and bolt at the frame rail and remove the upper suspension arm.

INSTALLATION

- (1) Position the upper suspension arm at the axle and frame rail.
- (2) Install the bolts and finger tighten the nuts.
- (3) Remove the supports and lower the vehicle.
- (4) Tighten the nut at the axle and frame bracket to 75 N·m (55 ft. lbs.).

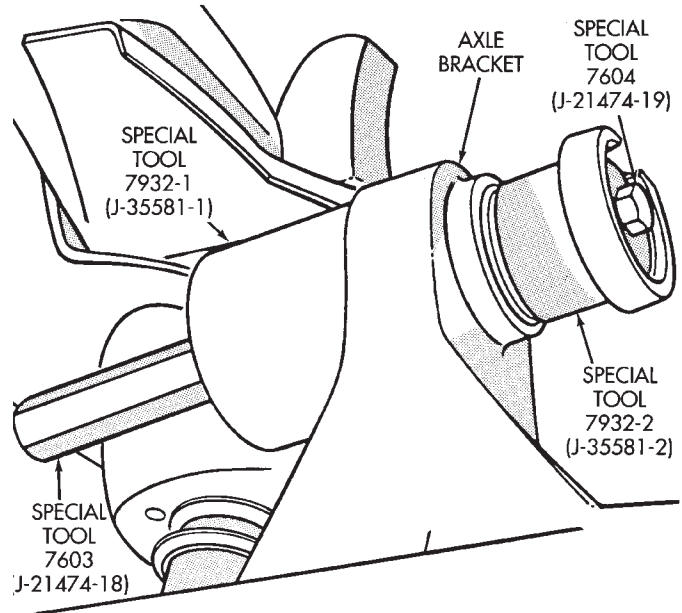
AXLE BUSHING**REMOVAL**

- (1) Remove the upper suspension arm from axle.

(2) Position spacer 7932-1 (J-35581-1) over the bushing in the axle for two-wheel drive axles and right side on Model 30 axle.

(3) Install Bushing Removal/Installer (Fig. 5).

(4) Remove the bushing by tightening the Long Nut.



J9302-9

Fig. 5 Bushing Removal

NOTE: For two-wheel drive axles and right side on Model 30 axle, do not remove spacer 7932-1 (J-35581-1). This spacer is need for installation.

INSTALLATION

- (1) Position new bushing, Receiver and Installer on axle (Fig. 6).
- (2) Install the bushing by tightening the Long Nut.
- (3) Remove tools and install the upper suspension arm.

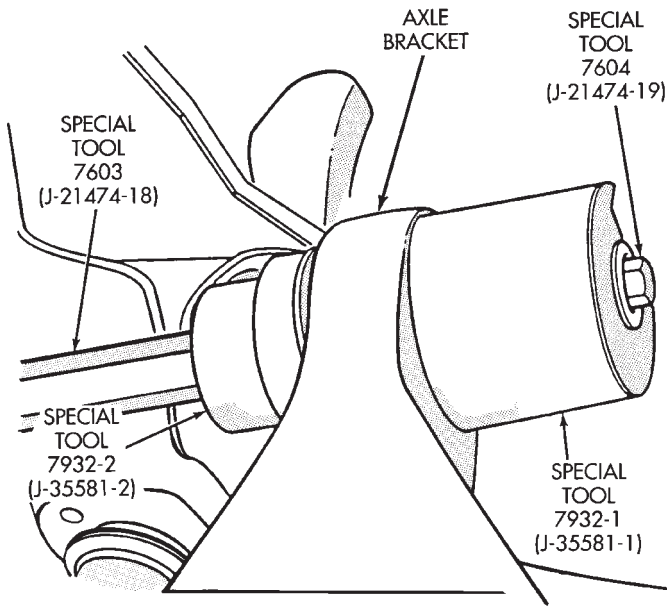
STABILIZER BAR**REMOVAL**

- (1) Raise and support the vehicle.
- (2) Remove upper link bolts (Fig. 7) and separate links from the stabilizer bar with Remover MB-990635.
- (3) Remove the stabilizer bar clamps bolts from the frame rails and remove the stabilizer bar.
- (4) Remove the stabilizer bar link nuts from the axle brackets (Fig. 7).

INSTALLATION

- (1) Position the stabilizer bar on the frame rail and install the clamps and bolts. Ensure the bar is

REMOVAL AND INSTALLATION (Continued)



J9302-8

Fig. 6 Bushing Installation

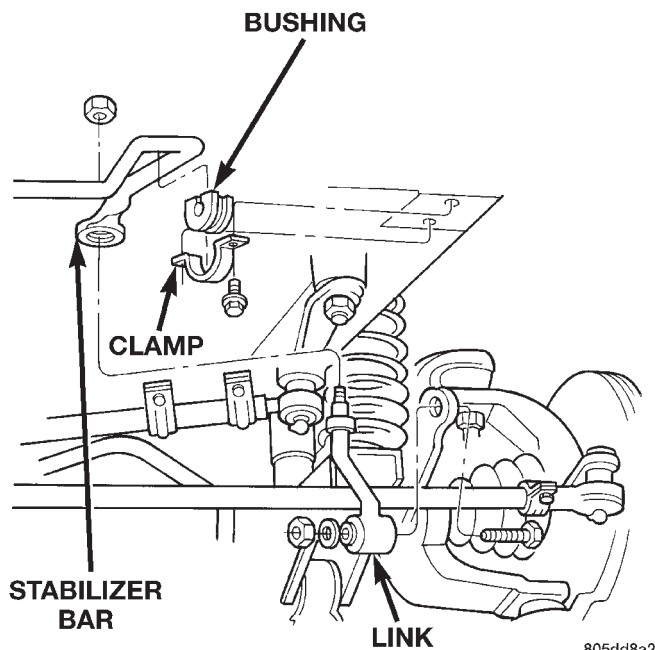


Fig. 7 Stabilizer Bar

centered with equal spacing on both sides. Tighten the bolts to 54 N·m (40 ft. lbs.).

(2) Install the links into the stabilizer bar and axle brackets.

(3) Tighten the nuts at the axle bracket end to 95 N·m (70 ft. lbs.).

(4) Tighten the stabilizer bar to link nuts to 61 N·m (45 ft. lbs.).

(5) Remove the supports and lower the vehicle.

(6) Tighten the nuts at the axle bracket end to 95 N·m (70 ft. lbs.).

TRACK BAR

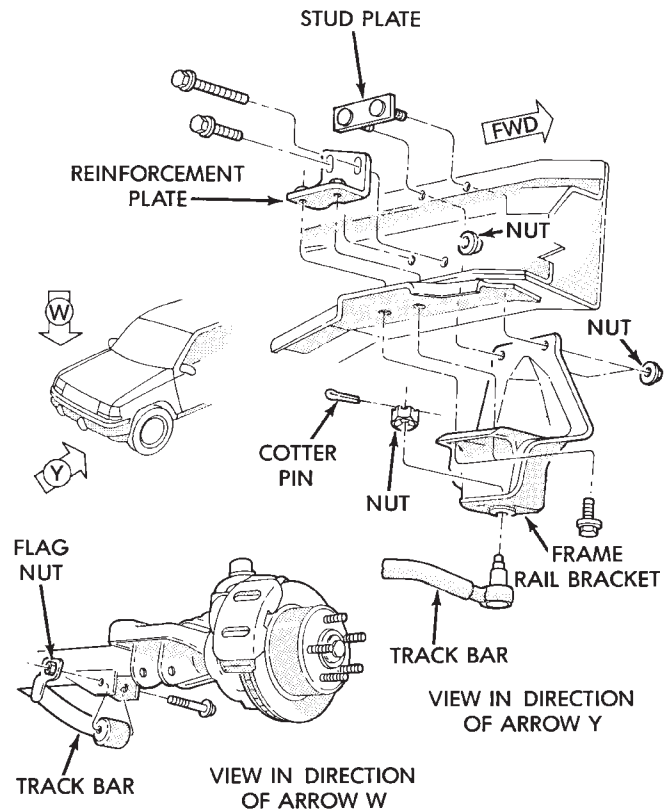
REMOVAL

(1) Raise and support the vehicle.

(2) Remove the cotter pin and nut from the ball stud end at the frame rail bracket (Fig. 8).

(3) Use a universal puller to separate the ball stud from the frame rail bracket.

(4) Remove the bolt and flag nut from the axle shaft tube bracket (Fig. 8). Remove the track bar.



J9302-1

Fig. 8 Track Bar

INSTALLATION

(1) Install the track bar at axle tube bracket. Loosely install the retaining bolt and flag nut.

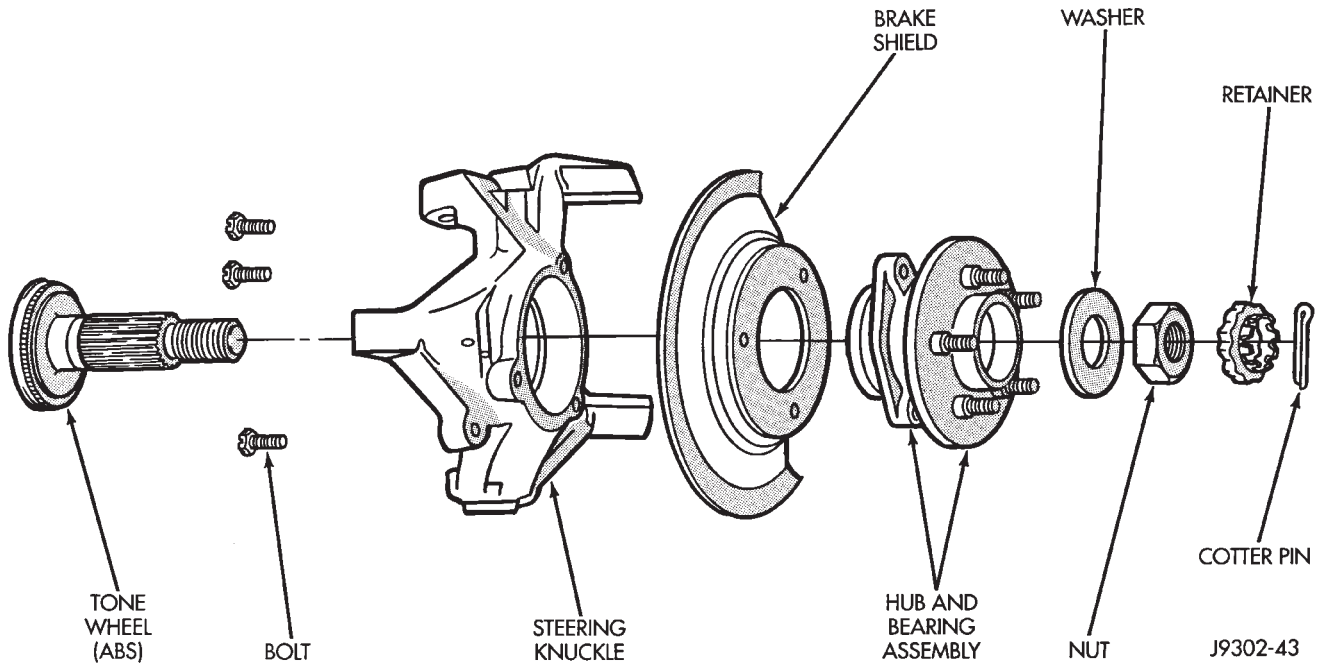
(2) It may be necessary to pry the axle assembly over to install the track bar at the frame rail. Install track bar at the frame rail bracket. Install the retaining nut on the stud.

(3) Tighten the ball stud nut to 81 N·m (60 ft. lbs.). Install a new cotter pin.

(4) Remove the supports and lower the vehicle.

(5) Tighten the bolt at the axle shaft tube bracket to 75 N·m (55 ft. lbs.).

(6) Check alignment if a new track bar was installed.

REMOVAL AND INSTALLATION (Continued)**Fig. 9 Hub Bearing & Knuckle****HUB BEARING****REMOVAL**

- (1) Raise and support the vehicle.
- (2) Remove the wheel and tire assembly.
- (3) Remove the brake caliper, rotor and ABS wheel speed sensor, refer to Group 5 Brakes.
- (4) Remove the cotter pin, nut retainer and axle hub nut (Fig. 9).
- (5) Remove the hub mounting bolts and remove hub bearing from the steering knuckle and axle shaft.

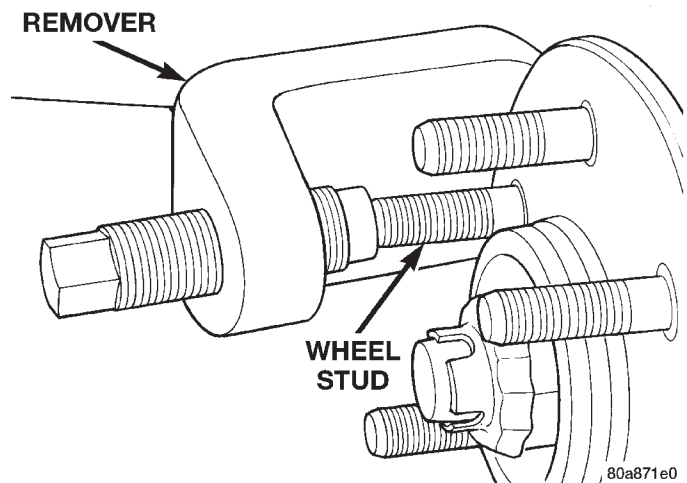
INSTALLATION

- (1) Install the hub bearing and brake dust shield to the knuckle.
- (2) Install the hub to knuckle bolts and tighten to 102 N·m (75 ft. lbs.).
- (3) Install the hub washer and nut. Tighten the hub nut to 237 N·m (175 ft. lbs.). Install the nut retainer and a new cotter pin.
- (4) Install the brake rotor, caliper and ABS wheel speed sensor, refer to Group 5 Brakes.
- (5) Install the wheel and tire assembly.
- (6) Remove support and lower the vehicle.

WHEEL MOUNTING STUDS**REMOVAL**

- (1) Raise and support vehicle.
- (2) Remove wheel and tire assembly.
- (3) Remove brake caliper and rotor, refer to Group 5 Brakes for procedure.

- (4) Remove stud from hub with Remover C-4150A (Fig. 10).

**Fig. 10 Wheel Stud Removal****INSTALLATION**

- (1) Install new stud into hub flange.
- (2) Install three washers onto stud, then install lug nut with the flat side of the nut against the washers.
- (3) Tighten lug nut until the stud is pulled into the hub flange. Verify that the stud is properly seated into the flange.
- (4) Remove lug nut and washers.
- (5) Install the brake rotor and caliper, refer to Group 5 Brakes for procedure.

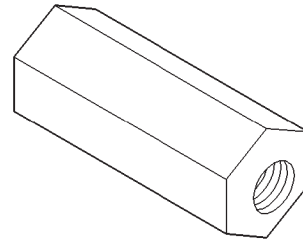
REMOVAL AND INSTALLATION (Continued)

- (6) Install wheel and tire assembly, use new lug nut on stud or studs that were replaced.
- (7) Remove support and lower vehicle.

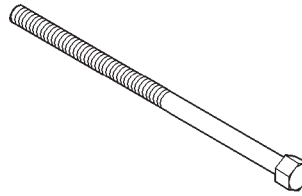
SPECIFICATIONS

TORQUE CHART

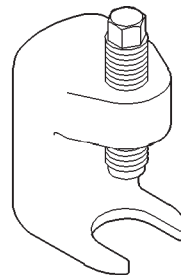
DESCRIPTION	TORQUE
Shock Absorber	
Upper Nut23 N·m (17 ft. lbs.)
Lower Nut28 N·m (21 ft. lbs.)
Suspension Arm Upper	
Nuts75 N·m (55 ft. lbs.)
Suspension Arm Lower	
Axle Bracket Nut115 N·m (85 ft. lbs.)
Frame Bracket Nut176 N·m (130 ft. lbs.)
Stabilizer Bar	
Clamp Bolt54 N·m (40 ft. lbs.)
Link Upper Nut61 N·m (45 ft. lbs.)
Link Lower Bolt95 N·m (70 ft. lbs.)
Track Bar	
Ball Stud Nut81 N·m (60 ft. lbs.)
Axle Bracket Bolt75 N·m (55 ft. lbs.)
Track Bar Bracket	
Bolts121 N·m (90 ft. lbs.)
Nut121 N·m (90 ft. lbs.)
Support Bolts95 N·m (70 ft. lbs.)
Hub Bearing	
Bolts102 N·m (75 ft. lbs.)



Nut, Long 7603 (J-21474-18)



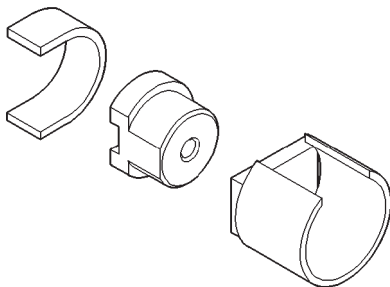
Bolt, Special 7604 (J-21474-19)



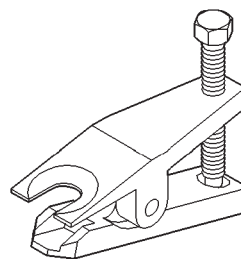
Remover C-4150A

SPECIAL TOOLS

FRONT SUSPENSION



Remover/Installer Suspension Bushing 7932 (J-35581)



8011d8e6

Remover Tie Rod End MB-990635

REAR SUSPENSION

INDEX

	page		page
DESCRIPTION AND OPERATION		SHOCK ABSORBER	13
REAR SUSPENSION	12	STABILIZER BAR	14
DIAGNOSIS AND TESTING		TRACK BAR	14
SHOCK DIAGNOSIS	13	UPPER SUSPENSION ARM	14
REMOVAL AND INSTALLATION		SPECIFICATIONS	
COIL SPRING	13	TORQUE CHART	15
LOWER SUSPENSION ARM	13		

DESCRIPTION AND OPERATION

REAR SUSPENSION

The rear suspension is link/coil design comprised of (Fig. 1):

- Drive axle
- Dual-action shock absorbers
- Coil springs
- Upper and lower suspension arms
- Track bar
- Stabilizer bar

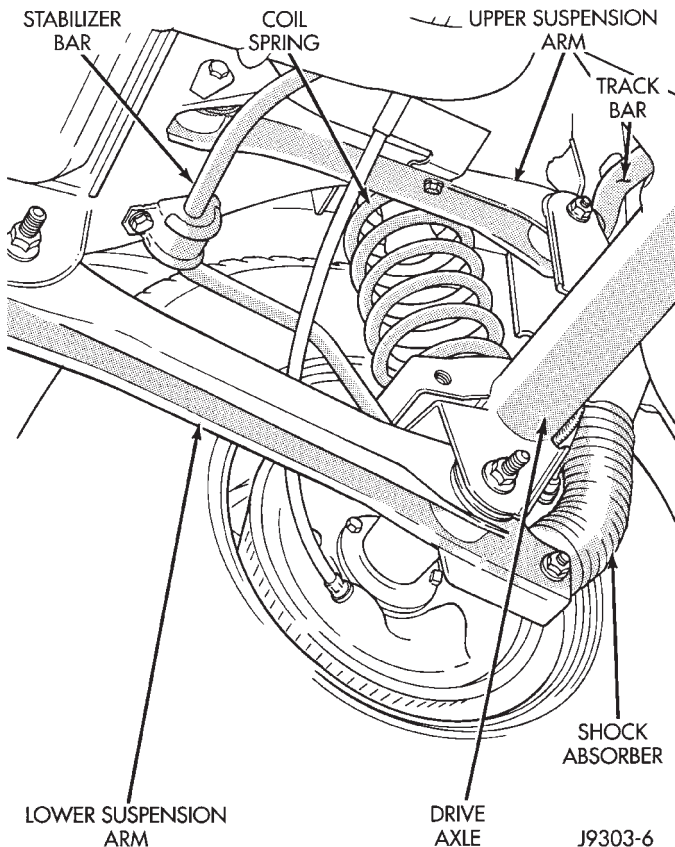


Fig. 1 Rear Suspension

Upper And Lower Suspension: The suspension arms use bushings to isolate road noise. The suspension arms are bolted to the body and axle through the rubber bushings. The lower suspension arm has provision for the use of cam bolts at the axle to allow for pinion angle or thrust angle adjustment. The cams are available as a service kit and are not installed at the factory. The suspension arm travel is limited through the use of jounce bumpers in compression and shock absorbers in rebound.

Shock Absorbers: The shock absorbers dampen jounce and rebound of the vehicle over various road conditions. The top of the shock absorbers are bolted to the body. The bottom of the shocks are bolted to the axle shock absorber bracket.

Coil Springs: The coil springs mount up in the fender shield that is part of the unitized body bracket. There is a rubber isolator between the top of the spring and bracket to isolate road noise. The bottom of the spring seats on the axle pad and is retained with a clip.

Stabilizer Bar: The stabilizer bar is used to control vehicle body roll during turns. The spring steel bar helps to equalize the vehicle body in relationship to the suspension. The bar extends across the underside of the chassis and connects to the frame rails. Links are connected from the bar to the axle brackets. Stabilizer bar are isolated by rubber bushings.

Track Bar: The track bar is used to control rear axle lateral movement. The track bar is attached to a frame rail bracket and an axle bracket. It is isolated with bushings at both ends.

CAUTION: Suspension components with rubber/urethane bushings (except stabilizer bar) should be tightened with the vehicle at normal ride height. It is important to have the springs supporting the weight of the vehicle when the fasteners are torqued. This will maintain vehicle ride comfort and prevent premature bushing wear.

DIAGNOSIS AND TESTING

SHOCK DIAGNOSIS

A knocking or rattling noise from a shock absorber may be caused by movement between mounting bushings and metal brackets or attaching components. These noises can usually be stopped by tightening the attaching nuts. If the noise persists, inspect for damaged and worn bushings, and attaching components. Repair as necessary if any of these conditions exist.

A squeaking noise from the shock absorber may be caused by the hydraulic valving and may be intermittent. This condition is not repairable and the shock absorber must be replaced.

The shock absorbers are not refillable or adjustable. If a malfunction occurs, the shock absorber must be replaced. To test a shock absorber, hold it in an upright position and force the piston in and out of the cylinder four or five times. The action throughout each stroke should be smooth and even.

The shock absorber bushings do not require any type of lubrication. Do not attempt to stop bushing noise by lubricating them. Grease and mineral oil-base lubricants will deteriorate the bushing.

REMOVAL AND INSTALLATION

SHOCK ABSORBER

REMOVAL

- (1) Raise and support the vehicle. Position a hydraulic jack under the axle to support it.
- (2) Remove the upper nut and retainer from the frame rail stud (Fig. 2).
- (3) Remove the lower nut and bolt from the axle bracket. Remove the shock absorber.

INSTALLATION

- (1) Install the shock absorber on the upper frame rail stud. Install the shock absorber on the axle bracket.
- (2) Install the retainer and nut on the stud. Tighten the upper nut to 70 N·m (52 ft. lbs.).
- (3) Install lower bolt and nut finger tight.
- (4) Remove the supports and lower the vehicle.
- (5) Tighten the lower nut to 92 N·m (68 ft. lbs.).

COIL SPRING

REMOVAL

- (1) Raise and support the vehicle. Position a hydraulic jack under the axle to support it.
- (2) Disconnect the stabilizer bar link and shock absorber from the axle bracket.

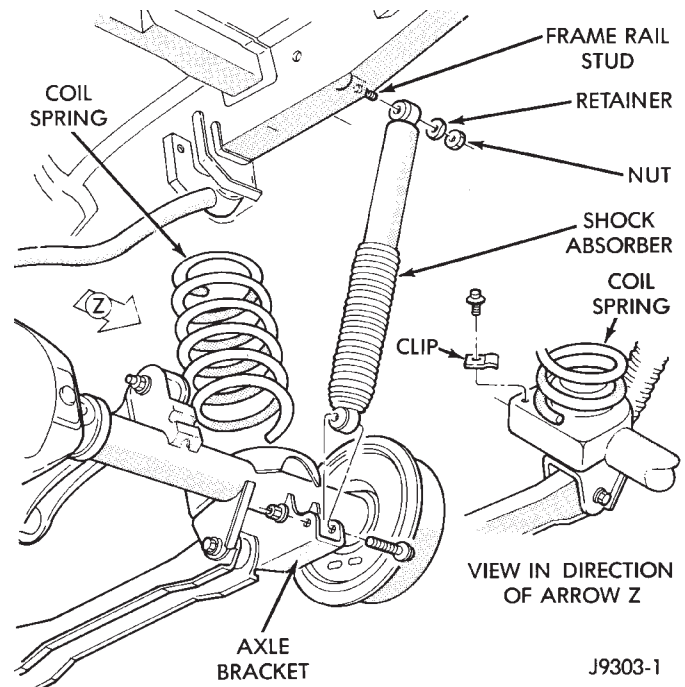


Fig. 2 Rear Coil Spring & Shock Absorber

- (3) Disconnect the track bar from the frame rail bracket.
- (4) Lower the axle until the spring is free from the upper mount seat. Remove the coil spring retainer bolt (Fig. 2) and remove the spring.

INSTALLATION

- Inspect isolator for damage or wear. Replace the isolator if necessary before installing spring.
- (1) Position the coil spring on the axle pad. Install the spring retainer and bolt. Tighten the bolt to 22 N·m (16 ft. lbs.).
 - (2) Raise the axle into position until the spring seats in the upper mount.
 - (3) Connect the stabilizer bar links and shock absorbers to the axle bracket. Connect the track bar to the frame rail bracket.
 - (4) Remove the supports and lower the vehicle.
 - (5) Tighten the track bar and shock absorber to specified torque.

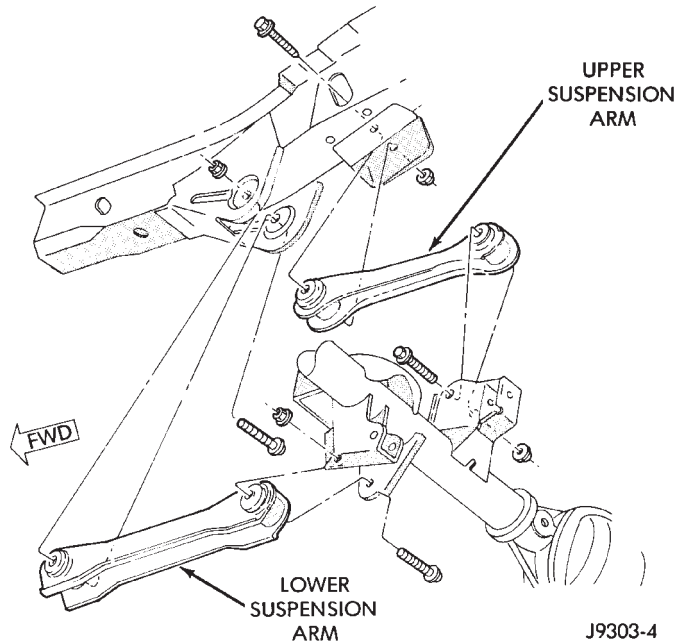
LOWER SUSPENSION ARM

REMOVAL

- (1) Raise and support the vehicle.
- (2) Remove the lower suspension arm nut and bolt at the axle bracket (Fig. 3).
- (3) Remove the nut and bolt (Fig. 3) at the frame rail and remove the lower suspension arm.

INSTALLATION

- (1) Position the lower suspension arm at the axle bracket and frame rail bracket.

REMOVAL AND INSTALLATION (Continued)**Fig. 3 Upper & Lower Suspension Arms**

- (2) Install the bolts and finger tighten the nuts.
- (3) Remove the supports and lower the vehicle.
- (4) Tighten the lower suspension arm nuts to 177 N·m (130 ft. lbs.).

UPPER SUSPENSION ARM**REMOVAL**

- (1) Raise and support the vehicle.
- (2) Remove the upper suspension arm nut and bolt at the axle bracket (Fig. 3). Remove the ABS wire bracket from the arm.
- (3) Remove the nut and bolt at the frame rail and remove the upper suspension arm.

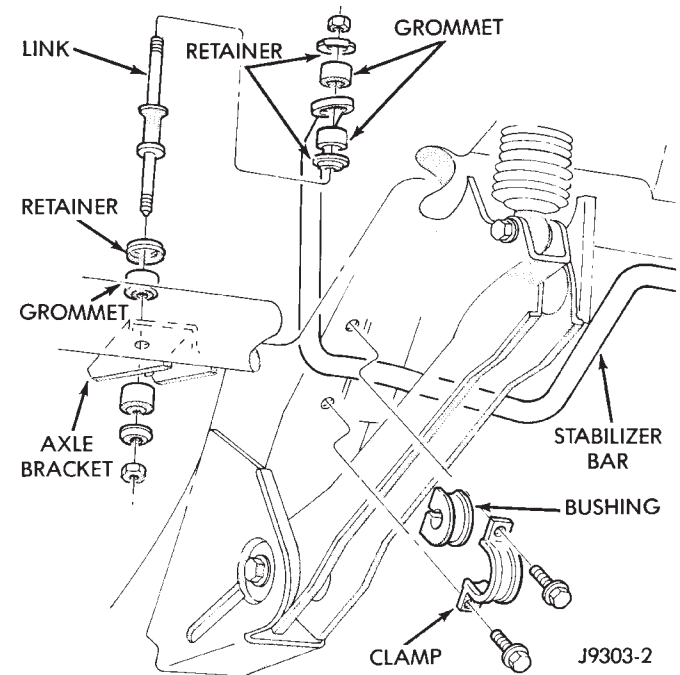
INSTALLATION

- (1) Position the upper suspension arm at the axle and frame rail.
- (2) Install the bolts and finger tighten the nuts. Install the ABS wire bracket onto the arm.
- (3) Remove the supports and lower the vehicle.
- (4) Tighten the upper suspension arm nuts to 75 N·m (55 ft. lbs.).

STABILIZER BAR**REMOVAL**

- (1) Raise and support the vehicle. Remove one wheel and tire.
- (2) Disconnect the stabilizer bar links from the axle brackets (Fig. 4).
- (3) Lower the exhaust by disconnecting the muffler and tail pipe hangers.
- (4) Disconnect the stabilizer bar from the links.

- (5) Disconnect the stabilizer bar clamps from the frame rails. Remove the stabilizer bar.

**Fig. 4 Rear Stabilizer Bar****INSTALLATION**

- (1) Position the stabilizer bar on the frame rail and install the clamps and bolts. Ensure the bar is centered with equal spacing on both sides. Tighten the bolts to 54 N·m (40 ft. lbs.).
- (2) Install the links and grommets onto the stabilizer bar and axle brackets. Install the nuts and tighten to 36 N·m (27 ft. lbs.).
- (3) Connect the muffler and tail pipe to their hangers.
- (4) Install the wheel and tire assembly.

TRACK BAR**REMOVAL**

- (1) Raise and support the vehicle.
- (2) Remove the bolt and nut from the frame rail bracket (Fig. 5).
- (3) Remove the bolt from the axle tube bracket (Fig. 5). Remove the track bar.

INSTALLATION

- (1) Install the track bar to the axle bracket and install a new bolt.
- (2) It may be necessary to pry the axle assembly over to install the track bar. Install the track bar to the frame rail bracket. Loosely install the bolt and flag nut.
- (3) Remove the supports and lower the vehicle.
- (4) Tighten the track bar bolts 100 N·m (74 ft. lbs.).

REMOVAL AND INSTALLATION (Continued)

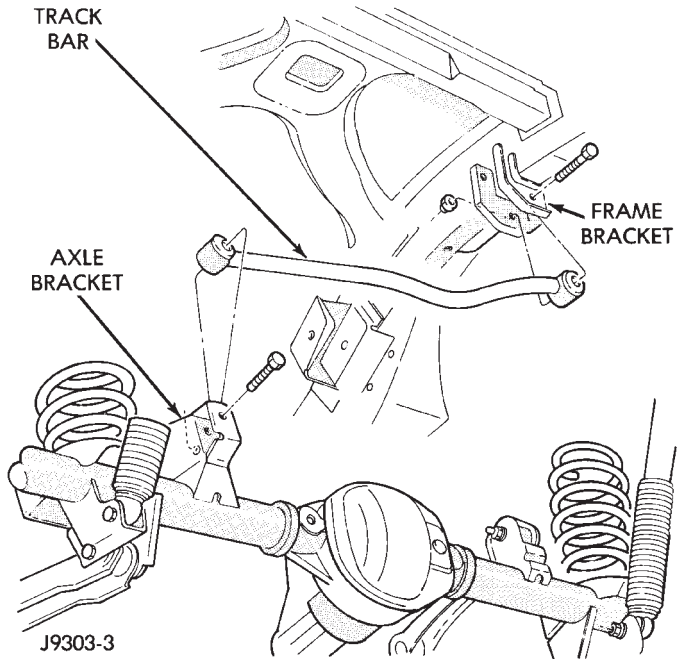


Fig. 5 Rear Track Bar

SPECIFICATIONS

TORQUE CHART

DESCRIPTION	TORQUE
Shock Absorber	
Upper Nut.70 N·m (52 ft. lbs.)
Lower Nut.92 N·m (68 ft. lbs.)
Suspension Arm Upper	
Nuts75 N·m (55 ft. lbs.)
Suspension Arm Lower	
Nuts177 N·m (130 ft. lbs.)
Stabilizer Bar	
Clamp Bolt54 N·m (40 ft. lbs.)
Link Nut.36 N·m (27 ft. lbs.)
Track Bar	
Frame Bracket Nut.100 N·m (74 ft. lbs.)
Axle Bracket Bolt100 N·m (74 ft. lbs.)

DIFFERENTIAL AND DRIVELINE

CONTENTS

	page	page	
181 FBI AXLE	16	216 RBA AXLE	88
194 RBI AXLE	52	PROPELLER SHAFTS	1

PROPELLER SHAFTS

INDEX

	page		page
GENERAL INFORMATION		REMOVAL AND INSTALLATION	
FRONT PROPELLER SHAFT	1	FRONT PROPELLER SHAFT	7
LUBRICATION	3	REAR PROPELLER SHAFT	8
PRECAUTIONS	4	DISASSEMBLY AND ASSEMBLY	
PROPELLER SHAFT JOINT ANGLE	2	DOUBLE CARDAN JOINT	10
PROPELLER SHAFT JOINTS	2	SINGLE CARDAN UNIVERSAL JOINT	8
PROPELLER SHAFTS	1	CLEANING AND INSPECTION	
DIAGNOSIS AND TESTING		SINGLE AND DOUBLE CARDAN JOINT	14
RUNOUT	5	ADJUSTMENTS	
UNBALANCE	4	AXLE PINION ANGLE ADJUSTMENT	14
VIBRATION	4	FRONT PROPELLER SHAFT MEASUREMENT ..	14
SERVICE PROCEDURES		SPECIFICATIONS	
DRIVELINE ANGLE MEASUREMENT		TORQUE	15
PREPARATION	6	SPECIAL TOOLS	
PROPELLER SHAFT ANGLE MEASUREMENT ...	6	PROPELLER SHAFT	15

GENERAL INFORMATION

PROPELLER SHAFTS

The function of a propeller shaft is to transmit power from one point to another in a smooth action. The shaft is designed to send torque through an angle from the transmission (transfer case on 4WD vehicles) to the axle (Fig. 1).

The propeller shaft must operate through constantly changing relative angles between the transmission and axle. It must also be capable of changing length while transmitting torque. The axle rides suspended by springs in a floating motion. This means the propeller shaft must be able to change angles when going over various roads. This is accomplished through universal joints, which permit the propeller shaft to operate at different angles. The slip joints (or yokes) permit contraction or expansion.

Tubular propeller shafts are balanced by the manufacturer with weights spot welded to the tube.

The propeller shaft is designed and built with the yoke lugs in line with each other which is called phasing. This design produces the smoothest running condition. An out of phase shaft can cause a vibration.

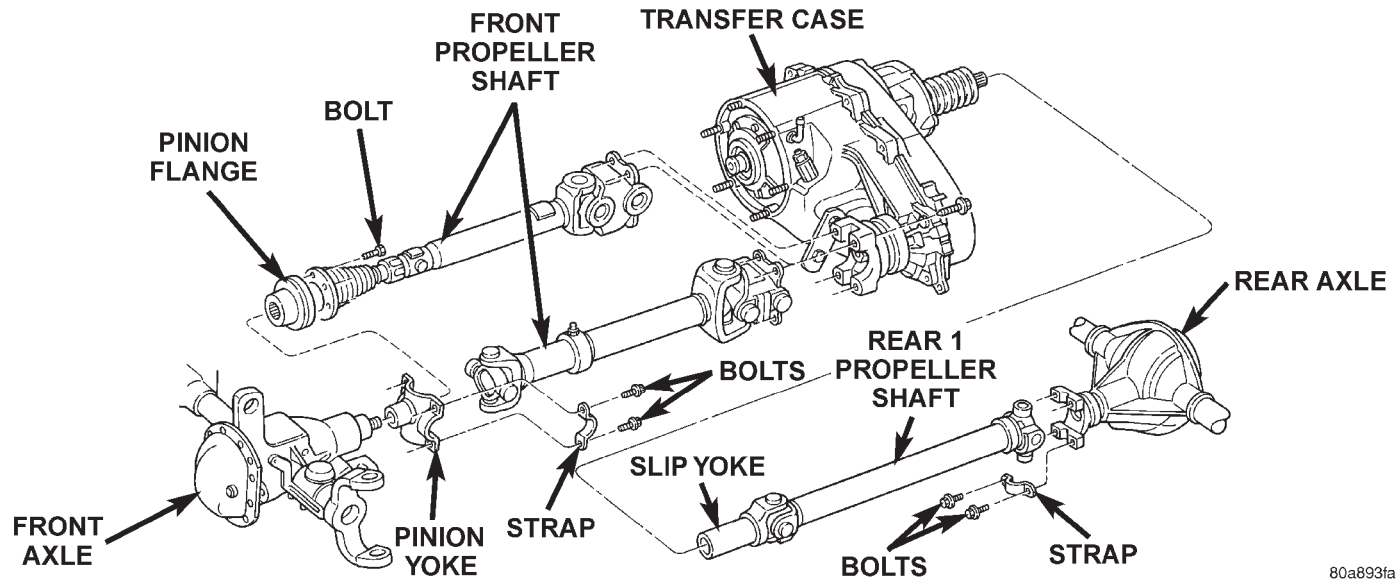
Before undercoating a vehicle, the propeller shaft and the U-joints should be covered. This will prevent the undercoating from causing an out of balance condition and vibration.

CAUTION: Use exact replacement parts for attaching the propeller shafts. This will ensure safe operation. The specified torque must always be applied when tightening the fasteners.

FRONT PROPELLER SHAFT

There are two front propeller shafts used on ZJ vehicles. Both shafts use a double cardan joint at the transfer case end. The difference between the two

GENERAL INFORMATION (Continued)



80a893fa

Fig. 1 Front & Rear Propeller Shafts

shafts is how they connect to the front axle and how they handle the variation in length required by suspension travel. The one shaft has a Constant Velocity (CV) joint at the axle end of the propeller shaft which contracts and extends as necessary. The CV joint has a splined shaft which allows the overall shaft length to be adjusted for optimum joint travel. This spline shaft is then locked in place with a nut. The second shaft uses a single Cardan universal joint at the axle and a slip yoke to handle length changes.

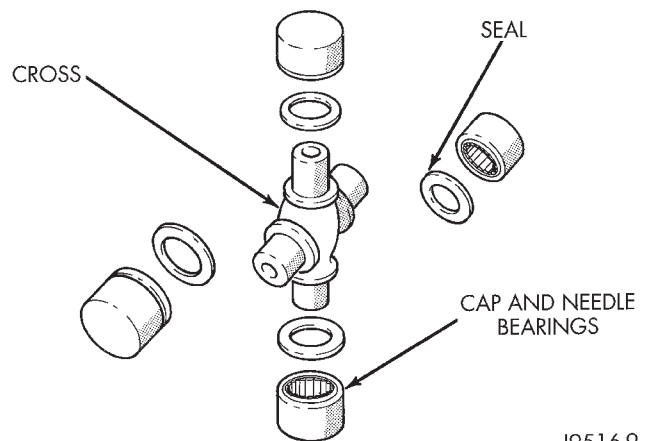
PROPELLER SHAFT JOINTS

Three different types of propeller shaft joints are used in ZJ vehicles (Fig. 2), (Fig. 3), and (Fig. 4). None of the three joints are serviceable. If worn or damaged, they must be replaced. If a vehicle has a damaged or worn Constant Velocity (CV) joint, or boot, the propeller shaft must be replaced.

PROPELLER SHAFT JOINT ANGLE

When two shafts come together at a common joint, the bend that is formed is called the operating angle. The larger the angle, the larger the amount of angular acceleration and deceleration of the joint. This speeding up and slowing down of the joint must be cancelled to produce a smooth power flow. This is done through the phasing of a propeller shaft and ensuring that the proper propeller shaft joint working angles are maintained.

A propeller shaft is properly phased when the yoke ends are in the same plane, or in line. A twisted



J9516-9

Fig. 2 Single Cardan U-Joint

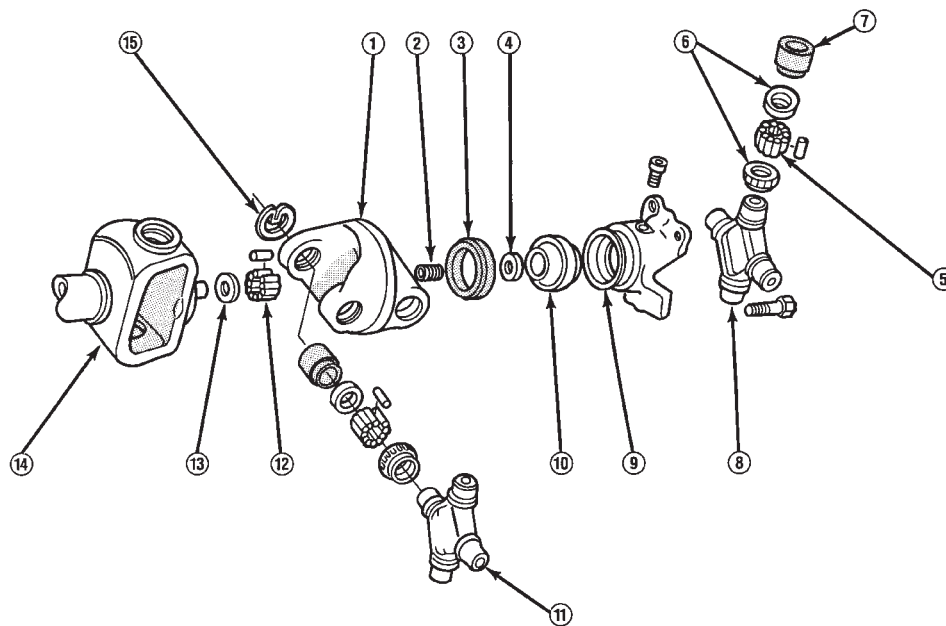
shaft will make the yokes out of phase and cause a noticeable vibration.

When taking propeller shaft joint angle measurements, or checking the phasing, of two piece shafts, consider each shaft separately.

Ideally the driveline system should have;

- Angles that are equal or opposite within 1 degree of each other.
- Have a 3 degree maximum operating angle.
- Have at least a 1/2 degree continuous operating (propeller shaft) angle.

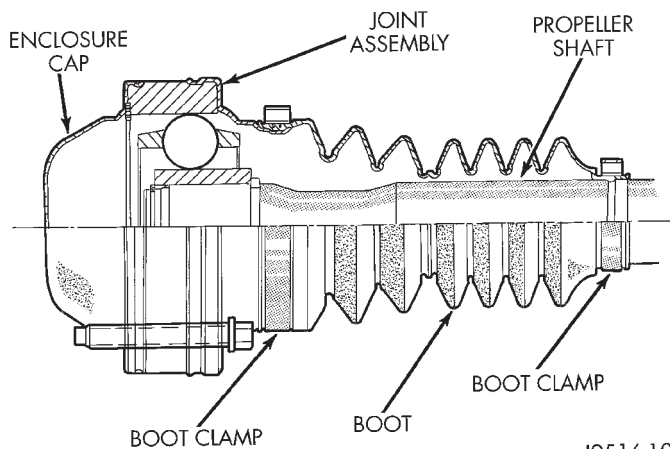
GENERAL INFORMATION (Continued)



- | | | |
|-------------------------|-----------------|----------------------|
| 1. LINK YOKE | 6. SEAL | 11. FRONT SPIDER |
| 2. SOCKET SPRING | 7. BEARING CAP | 12. NEEDLE BEARINGS |
| 3. SOCKET BALL RETAINER | 8. REAR SPIDER | 13. THRUST WASHER |
| 4. THRUST WASHER | 9. SOCKET YOKE | 14. DRIVE SHAFT YOKE |
| 5. NEEDLE BEARINGS | 10. SOCKET BALL | 15. RETAINING CLIP |

J9216-21

Fig. 3 Double Cardan U-Joint



J9516-10

Fig. 4 Constant Velocity Joint

Engine speed (rpm) is the main factor in determining the maximum allowable operating angle. As a guide to the maximum normal operating angles refer to (Fig. 5).

LUBRICATION

The slip yoke on the one style of front propeller shaft is equipped with a lubrication fitting. Use a multi-purpose NLGI Grade 2 EP lubricant. The factory installed universal joints are lubricated for the

PROPELLER SHAFT R.P.M.	MAX. NORMAL OPERATING ANGLES
5000	3°
4500	3°
4000	4°
3500	5°
3000	5°
2500	7°
2000	8°
1500	11°

J9316-4

Fig. 5 Maximum Angles And Engine Speed

life of the vehicle and do not need lubrication. All universal joints should be inspected for leakage and damage each time the vehicle is serviced. If seal leakage or damage exists, the universal joint should be replaced.

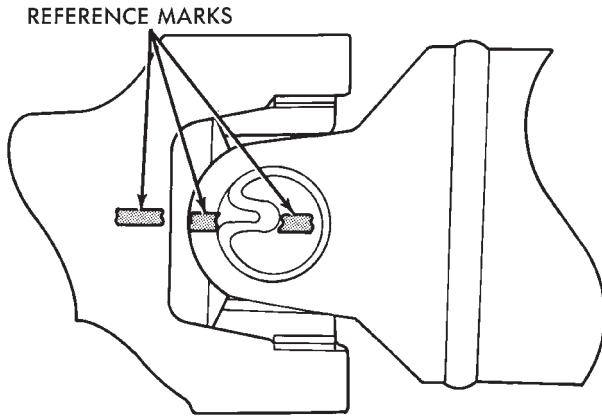
The Constant Velocity joint should also be inspected each time the vehicle is serviced. The CV joint boot is designed to last the life of the vehicle and to keep the joint lubricated. If grease leakage or boot damage is found, the propeller shaft must be replaced.

GENERAL INFORMATION (Continued)

PRECAUTIONS

Use the exact replacement parts when installing the propeller shafts. The use of the correct replacement parts helps to ensure safe operation. All fasteners must be torqued to the specified values for safe operation.

Also make alignment reference marks (Fig. 6) on the propeller shaft yoke and axle, or transmission, yoke prior to servicing. This helps to eliminate possible vibration.



J9316-2

Fig. 6 Reference Marks on Yokes

CAUTION: Do not allow the propeller shaft to drop or hang from any propeller shaft joint during removal. Attach the propeller shaft to the vehicle underside with wire to prevent damage to the joints.

CAUTION: It is very important to protect the external machined surface of the slip yoke from damage during and after propeller shaft removal. If the yoke is damaged, the transmission extension seal may be damaged and therefore cause a leak.

DIAGNOSIS AND TESTING

VIBRATION

Tires that are out-of-round, or wheels that are unbalanced, will cause a low frequency vibration. Refer to Group 22, Tires and Wheels, for additional information.

Brake drums that are unbalanced will cause a harsh, low frequency vibration. Refer to Group 5, Brakes, for additional information.

Driveline vibration can also result from loose or damaged engine mounts. Refer to Group 9, Engines, for additional information.

Propeller shaft vibration increases as the vehicle speed is increased. A vibration that occurs within a specific speed range is not usually caused by a propeller shaft being unbalanced. Defective universal joints, or an incorrect propeller shaft angle, are usually the cause of such a vibration.

UNBALANCE

NOTE: Removing and re-indexing the propeller shaft 180° relative to the yoke may eliminate some vibrations.

DRIVELINE VIBRATION

Drive Condition	Possible Cause	Correction
PROPELLER SHAFT	a. Undercoating or other foreign material on shaft. b. Loose U-joint clamp screws. c. Loose or bent U-joint yoke or excessive runout. d. Incorrect drive line angularity. e. Rear spring center bolt not in seat. f. Worn U-joint bearings. g. Propeller shaft damaged (bent tube) or out of balance. h. Broken rear spring. i. Excessive runout or unbalanced condition. j. Excessive drive pinion gear shaft yoke runout.	a. Clean exterior of shaft and wash with solvent. b. Tighten screws properly. c. Install replacement yoke. d. Correct angularity e. Loosen spring U-bolts and seat center bolts. f. Replace U-joint. g. Install replacement propeller shaft. h. Replace rear spring. i. Reindex propeller shaft 180°, test and correct as necessary. j. Reindex propeller shaft 180° and evaluate.
UNIVERSAL JOINT NOISE	a. U-joint clamp screws loose. b. Lack of lubrication.	a. Tighten screws with specified torque. b. Replace U-joint.

DIAGNOSIS AND TESTING (Continued)

If propeller shaft is suspected of being unbalanced, it can be verified with the following procedure:

- (1) Raise the vehicle.
- (2) Clean all the foreign material from the propeller shaft and the universal joints.
- (3) Inspect the propeller shaft for missing balance weights, broken welds, and bent areas. **If the propeller shaft is bent, it must be replaced.**
- (4) Inspect the universal joints to ensure that they are not worn, are properly installed, and are correctly aligned with the shaft.
- (5) Check the universal joint clamp screws torque.
- (6) Remove the wheels and tires. Install the wheel lug nuts to retain the brake drums or rotors.
- (7) Mark and number the shaft six inches from the yoke end at four positions 90° apart.
- (8) Run and accelerate the vehicle until vibration occurs. Note the intensity and speed the vibration occurred. Stop the engine.
- (9) Install a screw clamp at position 1 (Fig. 7).

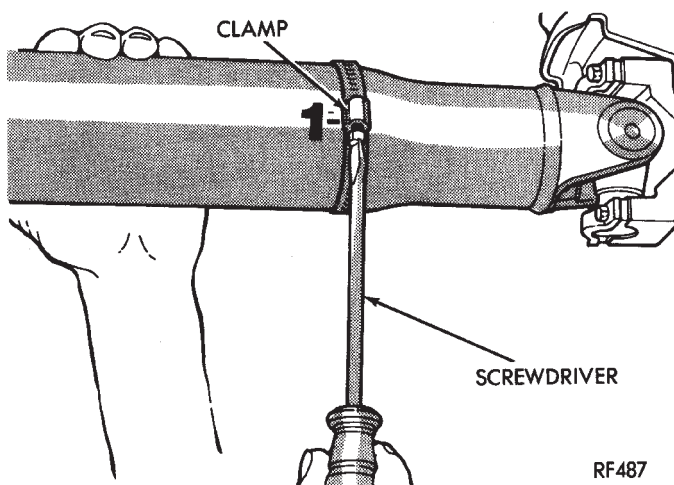


Fig. 7 Clamp Screw At Position 1

(10) Start the engine and re-check for vibration. If there is little or no change in vibration, move the clamp to one of the other three positions. Repeat the vibration test.

(11) If there is no difference in vibration at the other positions, the source of the vibration may not be propeller shaft.

(12) If the vibration decreased, install a second clamp (Fig. 8) and repeat the test.

(13) If the additional clamp causes an additional vibration, separate the clamps (1/4 inch above and below the mark). Repeat the vibration test (Fig. 9).

(14) Increase distance between the clamp screws and repeat the test until the amount of vibration is at the lowest level. Bend the slack end of the clamps so the screws will not loosen.

(15) If the vibration remains unacceptable, apply the same steps to the front end of the propeller shaft.

(16) Install the wheel and tires. Lower the vehicle.

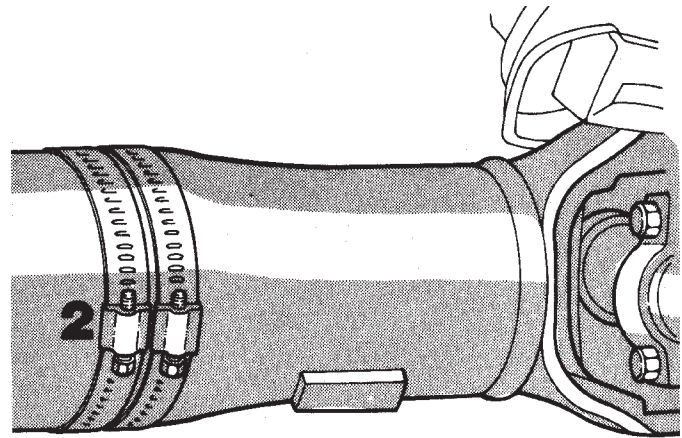


Fig. 8 Two Clamp Screws At The Same Position

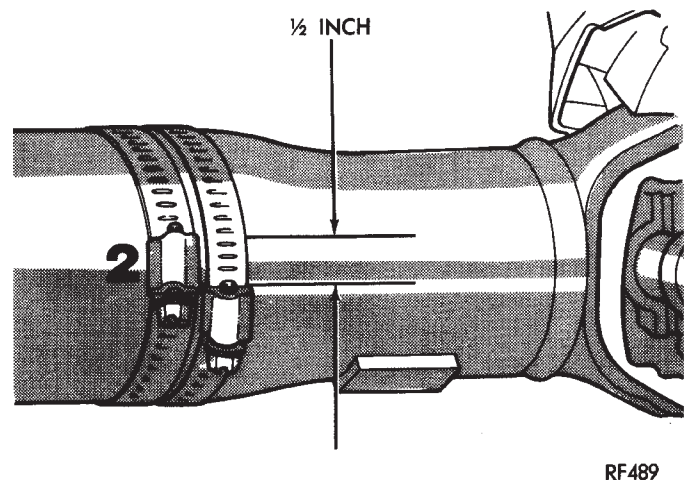


Fig. 9 Clamp Screws Separated

RUNOUT

(1) Remove dirt, rust, paint, and undercoating from the propeller shaft surface where the dial indicator will contact the shaft.

(2) The dial indicator must be installed perpendicular to the shaft surface.

(3) Measure runout at the center and ends of the shaft sufficiently far away from weld areas to ensure that the effects of the weld process will not enter into the measurements.

(4) Refer to Runout Specifications chart.

(5) If the propeller shaft run-out is out of specification, remove the propeller shaft, index the shaft 180°, and re-install the propeller shaft. Measure shaft runout again.

(6) If the propeller shaft runout is now within specifications, mark the shaft and yokes for proper orientation.

(7) If the propeller shaft runout is not within specifications, verify that the runout of the transmission/transfer case and axle are within specifications.

DIAGNOSIS AND TESTING (Continued)

Correct as necessary and re-measure propeller shaft runout.

(8) Replace the propeller shaft if the runout still exceeds the limits.

RUNOUT SPECIFICATIONS

Front of shaft	0.010 in. (0.25 mm)
Center of shaft	0.015 in. (0.38 mm)
Rear of shaft	0.010 in. (0.25 mm)
NOTE: Measure front/rear runout approximately 3 inches (76 mm) from the weld seam at each end of the shaft tube for tube lengths over 30 inches. Under 30 inches the max. runout is 0.20 inch for full length of the tube.	

J9116-15

SERVICE PROCEDURES

DRIVELINE ANGLE MEASUREMENT PREPARATION

Before measuring universal joint angles, the following must be done;

- Inflate all tires to correct pressure.
- Check the angles in the same loaded or unloaded condition as when the vibration occurred. Propeller shaft angles change according to the amount of load in the vehicle.
- Check the condition of all suspension components and verify all fasteners are torqued to specifications.
- Check the condition of the engine and transmission mounts and verify all fasteners are torqued to specifications.

PROPELLER SHAFT ANGLE MEASUREMENT

To accurately check driveline alignment, raise and support the vehicle at the axles as level as possible. Allow the wheels and propeller shaft to turn. Remove any external bearing snap rings, if equipped, from universal joint so that the inclinometer base sits flat.

The same basic procedure applies to both styles of front propeller shafts and the rear propeller shaft. To obtain the front (output) angle on the CV style front propeller shaft, the inclinometer is placed on the machined ring of the pinion flange. To obtain the propeller shaft angle measurement on the CV style front propeller shaft, the inclinometer is placed on the propeller shaft tube.

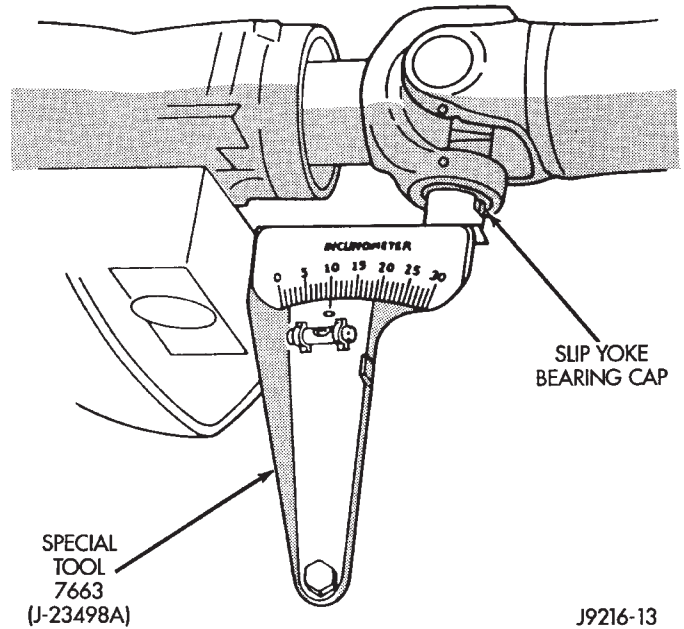
(1) Rotate the shaft until transmission/transfer case output yoke bearing cap is facing downward, if necessary.

Always make measurements from front to rear.

(2) Place Inclinometer on yoke bearing cap, or the pinion flange ring, (A) parallel to the shaft (Fig. 10).

Center bubble in sight glass and record measurement.

This measurement will give you the transmission or Output Yoke Angle (A).

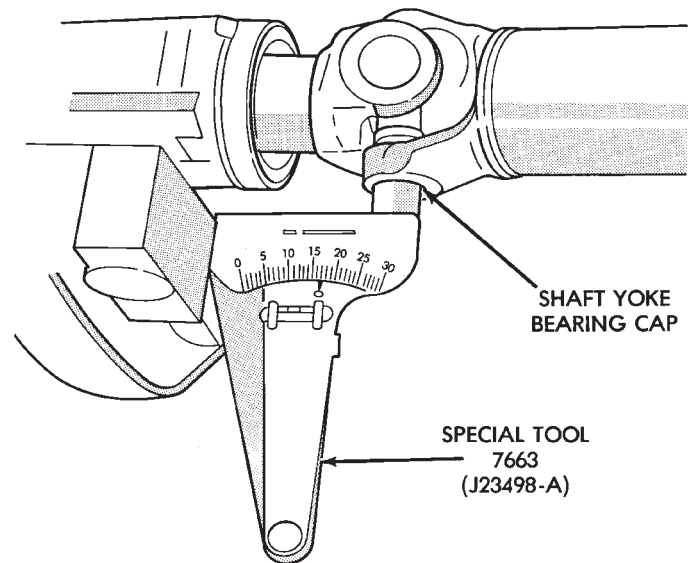


J9216-13

Fig. 10 Front (Output) Angle Measurement (A)

(3) Rotate propeller shaft 90 degrees and place Inclinometer on yoke bearing cap, or propeller shaft tube on CV style propeller shaft, parallel to the shaft (Fig. 11). Center bubble in sight glass and record measurement. This measurement can also be taken at the rear end of the shaft.

This measurement will give you the propeller shaft angle (C).



J9216-9

Fig. 11 Propeller Shaft Angle Measurement (C)

SERVICE PROCEDURES (Continued)

(4) Subtract smaller figure from larger (C minus A) to obtain transmission output operating angle.

(5) Rotate propeller shaft 90 degrees and place Inclinometer on pinion yoke bearing cap parallel to the shaft (Fig. 12). Center bubble in sight glass and record measurement.

This measurement will give you the pinion shaft or input yoke angle (B).

(6) Subtract smaller figure from larger (C minus B) to obtain axle Input Operating Angle.

Refer to rules given below and the example in (Fig. 13) for additional information.

- Good cancellation of U-joint operating angles (within 1°).
- Operating angles less than 3°.
- At least 1/2 of one degree continuous operating (propeller shaft) angle.

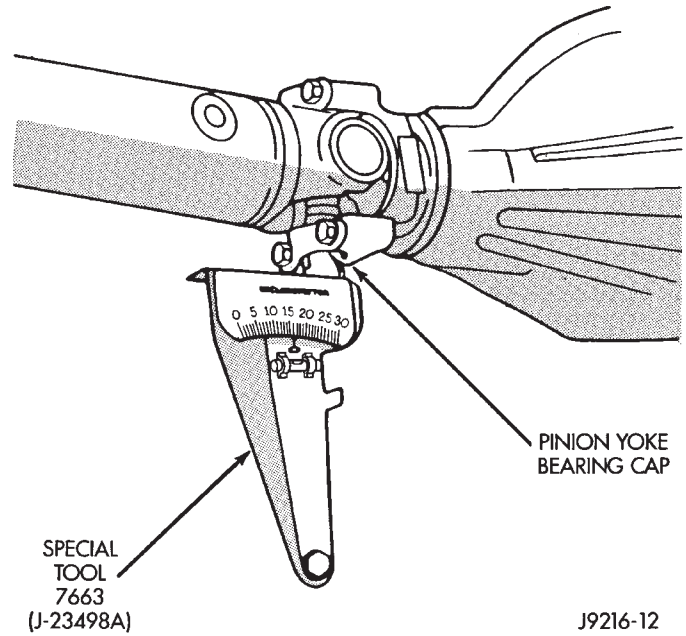


Fig. 12 Rear (Input) Angle Measurement (B)

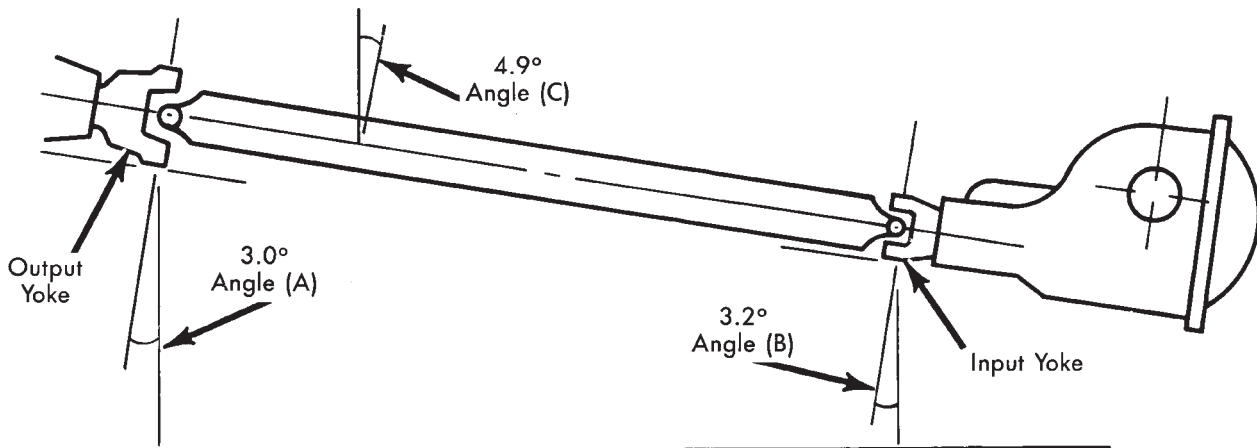
REMOVAL AND INSTALLATION

FRONT PROPELLER SHAFT

NOTE: If front propeller shaft must be replaced, the new shaft length must be measured and adjusted before the vehicle is returned to use.

REMOVAL

- (1) Raise and support vehicle on safety stands.
- (2) Shift the transmission and transfer case, if necessary, into the Neutral position.
- (3) Using a suitable marker, mark a line across the yoke at the transfer case, the link yoke, and pro-



Horizontal Level

(A) Output Yoke = 3.0°	4.9°
(C) Prop. Shaft = 4.9°	or -3.0°
Transmission Output Operating Angle	1.9°

(B) Axle Input Yoke = 3.2°	4.9°
(C) Prop. Shaft = 4.9°	or -3.2°
Axle Input Operating Angle	1.7°

Trans. Output Operating Angle	1.9°
Axle Input Operating Angle	-1.7°
Amount of U-Joint Cancellation	0.2°

J9316-3

Fig. 13 Universal Joint Angle Example

REMOVAL AND INSTALLATION (Continued)

propeller shaft yoke at the rear of the front propeller shaft for installation reference.

(4) Mark a line across the propeller shaft yoke, or CV joint, and the pinion shaft yoke, or pinion flange, for installation reference.

CAUTION: Do not loosen lock nut on the CV joint style propeller shaft or collapse the front propeller shaft. Driveline vibration can result.

(5) Remove bolts holding the front universal joint, or CV joint, to the pinion yoke, or flange.

(6) Remove bolts holding rear universal joint to the transfer case yoke.

(7) Separate the rear universal joint from the transfer case yoke.

(8) Push rear of propeller shaft upward to clear transfer case yoke.

(9) Separate front universal joint, or CV joint, from front axle.

(10) Separate propeller shaft from vehicle.

INSTALLATION

(1) Position front propeller shaft under vehicle with rear universal joint over the transfer case yoke.

(2) Place front universal joint, or CV joint, into the axle pinion yoke, or flange. CV joint should rotate freely in the pinion flange.

(3) Align mark on the rear link yoke and universal joint to the mark on the transfer case yoke.

(4) Loosely install bolts to hold universal joint to transfer case yoke.

(5) Align mark on front universal joint, or CV joint, to the mark on the axle pinion yoke, or flange.

(6) Install bolts to hold front universal joint, or CV joint, to axle pinion yoke, or flange. Tighten bolts to 41 N-m (30 ft. lbs.) for the CV style propeller shaft and 19 N-m (14 ft. lbs) for the universal joint style propeller shaft.

(7) Tighten bolts to hold universal joint to transfer case yoke to 27 N-m (20 ft. lbs.).

(8) Lower vehicle and road test to verify repair.

REAR PROPELLER SHAFT**REMOVAL**

(1) Raise and support vehicle on safety stands.

(2) Shift the transmission and transfer case, if necessary, to their Neutral positions.

(3) Using a suitable marker, mark a line across the axle pinion yoke and the propeller shaft yoke for installation reference.

(4) Remove the bolts holding the universal joint clamps to the pinion yoke.

(5) Slide the slip yoke off of the transmission, or transfer case, output shaft and remove the propeller shaft (Fig. 14).

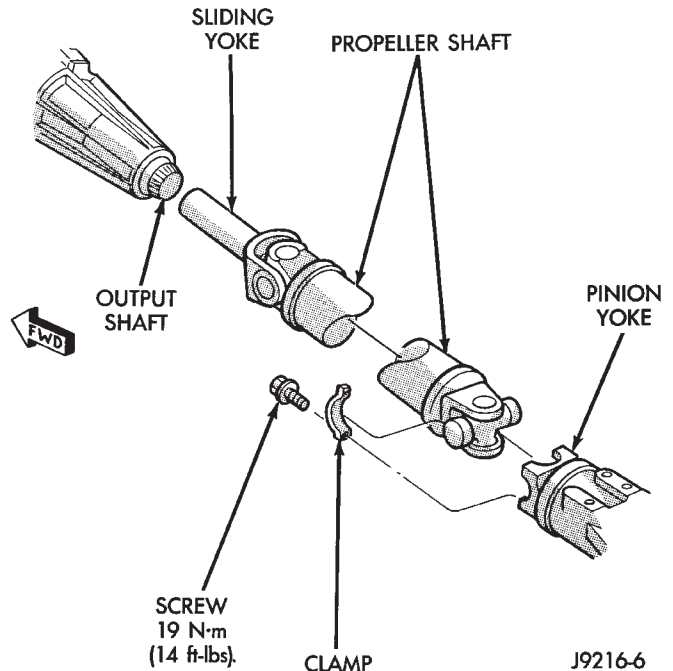


Fig. 14 Rear Propeller Shaft

INSTALLATION

(1) Slide the slip yoke on the transmission, or transfer case, output shaft.

(2) Align the installation reference marks made on the propeller shaft and pinion yoke.

(3) Position universal joint into pinion yoke.

(4) Install the universal joint clamp and clamp bolts to the pinion yoke. Tighten bolts to 19 N-m (14 ft. lbs.).

(5) Lower the vehicle.

DISASSEMBLY AND ASSEMBLY**SINGLE CARDAN UNIVERSAL JOINT****DISASSEMBLY**

Individual components of cardan universal joints are not serviceable. If worn or leaking, they must be replaced as an assembly.

(1) Remove the propeller shaft.

(2) Using a soft drift, tap the outside of the bearing cap assembly to loosen snap ring.

(3) Remove snap rings from both sides of yoke (Fig. 15).

(4) Set the yoke in an arbor press or vise with a socket whose inside diameter is large enough to receive the bearing cap positioned beneath the yoke.

(5) Position the yoke with the grease fitting, if equipped, pointing up.

(6) Place a socket with an outside diameter smaller than the upper bearing cap on the upper bearing cap and press the cap through the yoke to release the lower bearing cap (Fig. 16).

DISASSEMBLY AND ASSEMBLY (Continued)

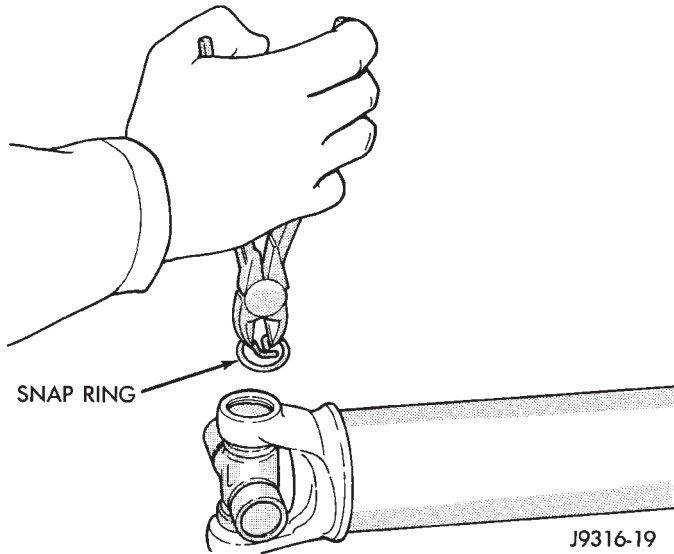


Fig. 15 Remove Snap Ring

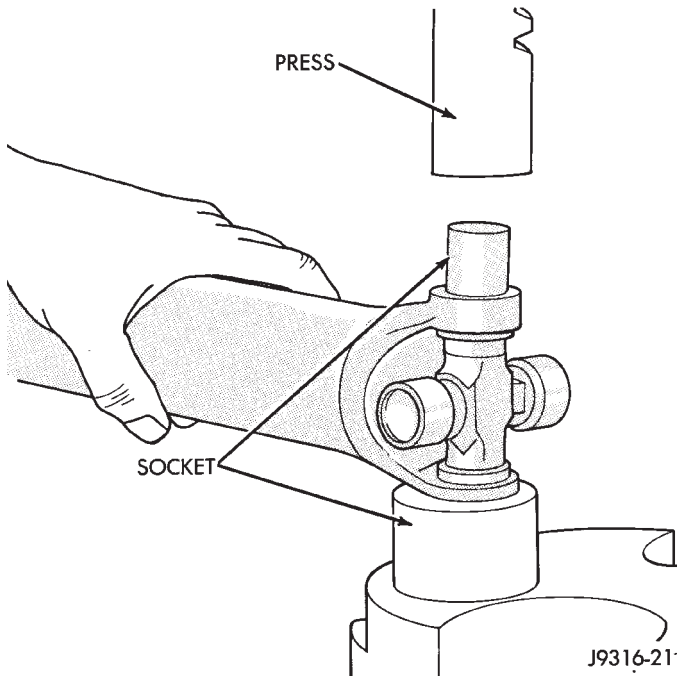


Fig. 16 Press Out Bearing

(7) If the bearing cap will not pull out of the yoke by hand after pressing, tap the yoke ear near the bearing cap to dislodge the cap.

(8) To remove the opposite bearing cap, turn the yoke over and straighten the cross in the open hole. Then, carefully press the end of the cross until the remaining bearing cap can be removed (Fig. 17).

CAUTION: If the cross or bearing cap are not straight during installation, the bearing cap will score the walls of the yoke bore and damage can occur.

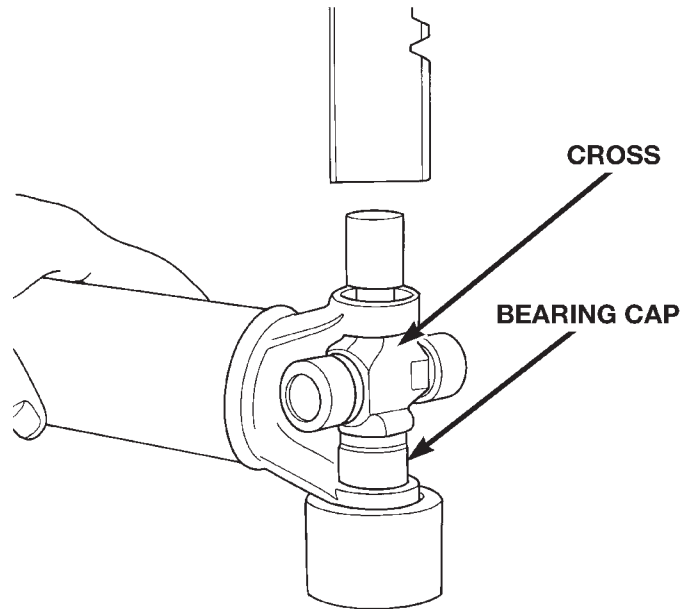


Fig. 17 Press Out Remaining Bearing

ASSEMBLY

(1) Apply extreme pressure (EP) N.L.G.I. Grade 1 or 2 grease to inside of yoke bores to aid in installation.

(2) Position the cross in the yoke with its lube fitting, if equipped, pointing up (Fig. 18).

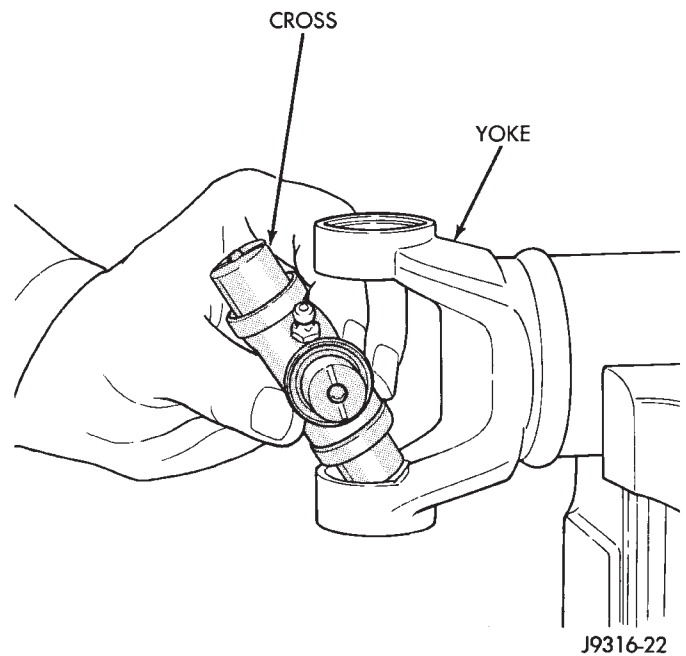
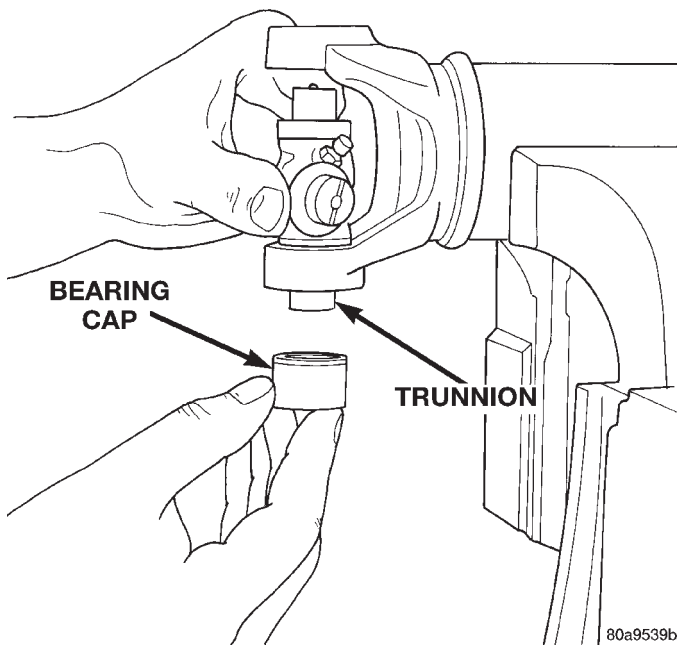


Fig. 18 Install Cross In Yoke

(3) Place a bearing cap over the trunnion and align the cap with the yoke bore (Fig. 19). Keep the needle bearings upright in the bearing assembly. A

DISASSEMBLY AND ASSEMBLY (Continued)**Fig. 19 Install Bearing On Trunnion**

needle bearing lying at the bottom of the cap will prevent proper assembly.

(4) Press the bearing cap into the yoke bore enough to install a snap ring.

(5) Install a snap ring.

(6) Repeat Step 3 and Step 4 to install the opposite bearing cap. If the joint is stiff or binding, strike the yoke with a soft hammer to seat the needle bearings.

(7) Add grease to lube fitting, if equipped.

(8) Install the propeller shaft.

DOUBLE CARDAN JOINT**DISASSEMBLY**

Individual components of cardan universal joints are not serviceable. If worn or leaking, they must be replaced as an assembly.

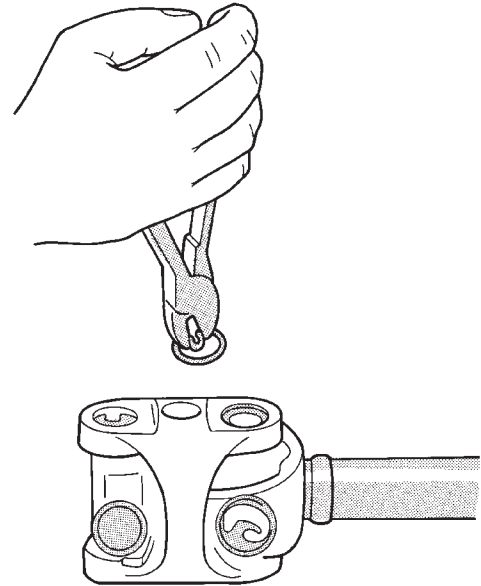
(1) Remove the propeller shaft.

(2) Using a soft drift, tap the outside of the bearing cap assembly to loosen snap ring.

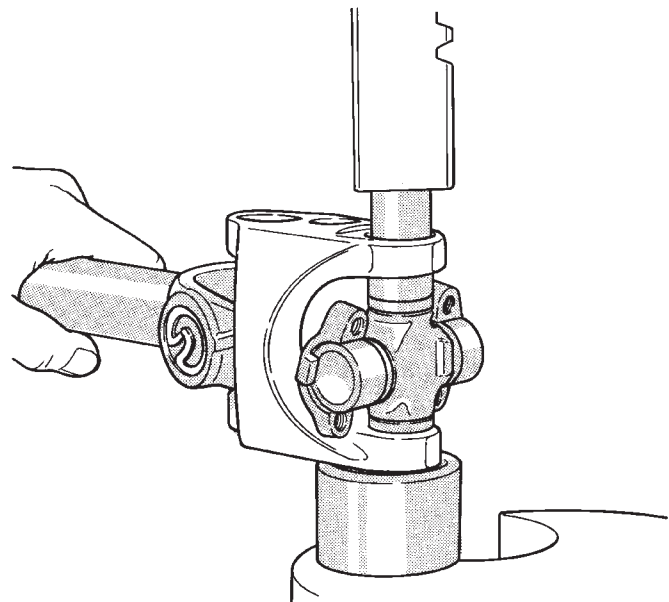
(3) Remove all the bearing cap snap rings (Fig. 20).

(4) Set the joint in an arbor press or vise with a socket whose inside diameter is large enough to receive the bearing cap positioned beneath the link yoke.

(5) Place a socket with an outside diameter smaller than the upper bearing cap on the upper bearing cap and partially press one bearing cap from the outboard side of the link yoke enough to grasp the bearing cap with vise jaws (Fig. 21). Be sure to remove grease fittings that interfere with removal.



J9316-5

Fig. 20 Remove Snap Rings

J9316-6

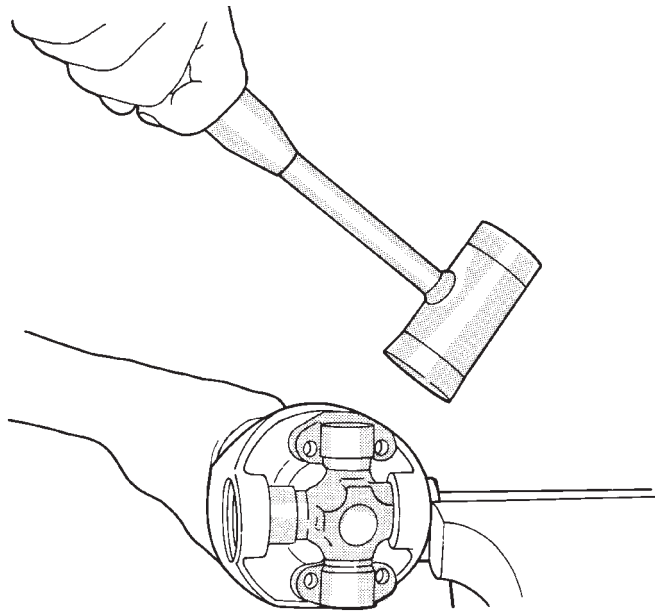
Fig. 21 Press Out Bearing

(6) Grasp the protruding bearing by vise jaws. Tap the link yoke with a mallet and drift to dislodge the bearing cap from the yoke (Fig. 22).

(7) Flip assembly and repeat Step 4, Step 5, and Step 6 to remove the opposite bearing cap. This will then allow removal of the cross centering kit assembly and spring (Fig. 23).

(8) Press the remaining bearing caps out the other end of the link yoke as described above to complete the disassembly.

DISASSEMBLY AND ASSEMBLY (Continued)

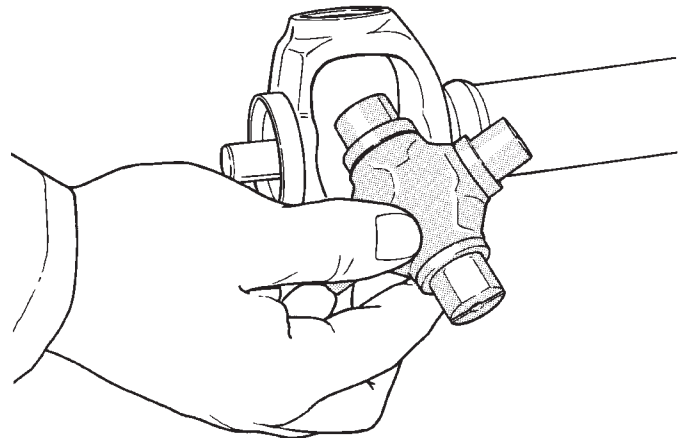


J9316-7

Fig. 22 Remove Bearing From Yoke

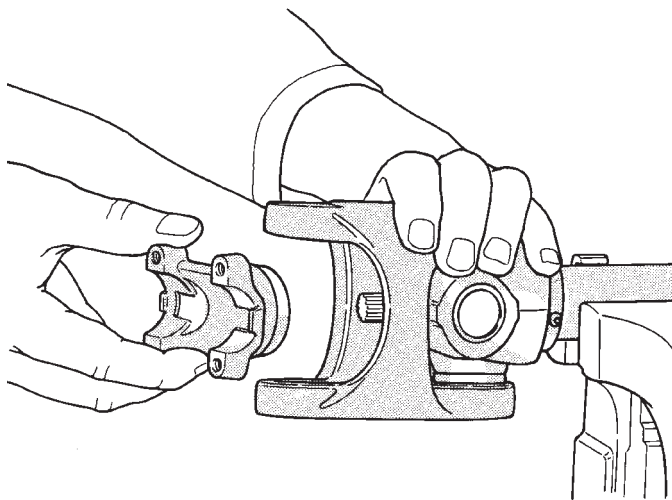
(2) Fit a cross into the propeller shaft yoke (Fig. 24).

(3) Place a bearing cap over the trunnion and align the cap with the yoke bore (Fig. 25). Keep the needle bearings upright in the bearing assembly. A needle bearing lying at the bottom of the cap will prevent proper assembly.



J9316-9

Fig. 24 Install Cross In Yoke



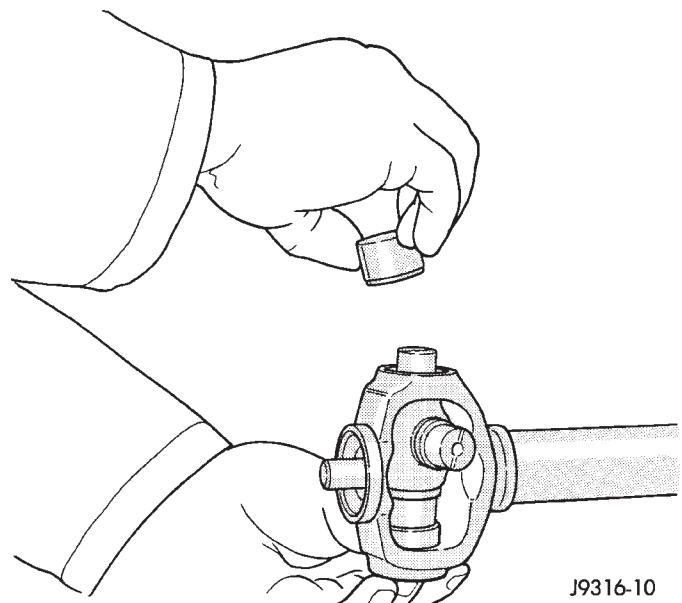
J9316-8

Fig. 23 Remove Centering Kit

ASSEMBLY

During assembly, ensure that the alignment marks on the link yoke and propeller shaft yoke are aligned.

(1) Apply extreme pressure (EP) N.L.G.I. Grade 1 or 2 grease to inside of yoke bores to aid in installation.



J9316-10

Fig. 25 Install Bearing Cap

DISASSEMBLY AND ASSEMBLY (Continued)

(4) Press the bearing cap into the yoke bore enough to install a snap ring (Fig. 26).

(5) Install a snap ring.

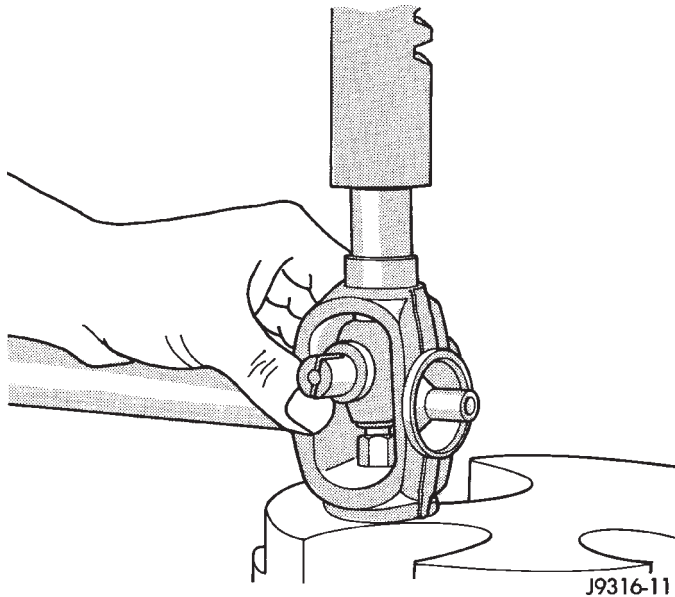


Fig. 26 Press In Bearing Cap

(6) Flip the propeller shaft yoke and install the bearing cap onto the opposite trunnion. Install a snap ring (Fig. 27).

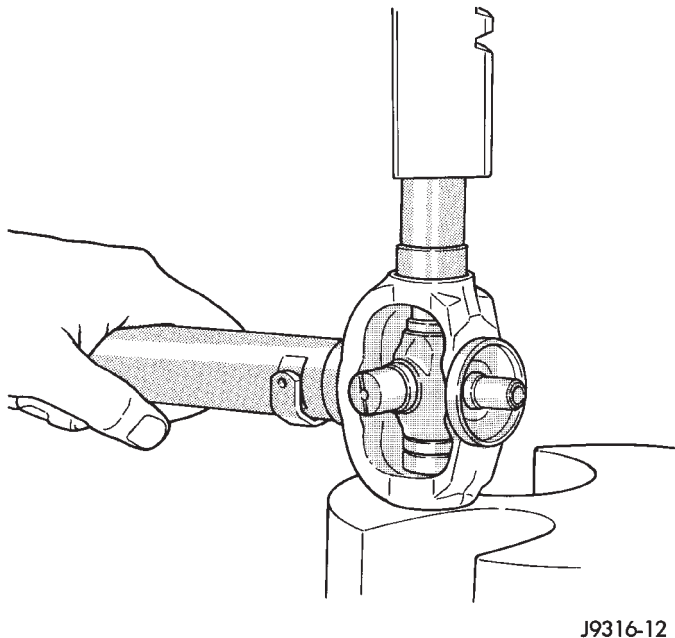


Fig. 27 Press In Bearing Cap

(7) Fit the link yoke on the remaining two trunnions and press both bearing caps into place (Fig. 28).

(8) Install snap rings.

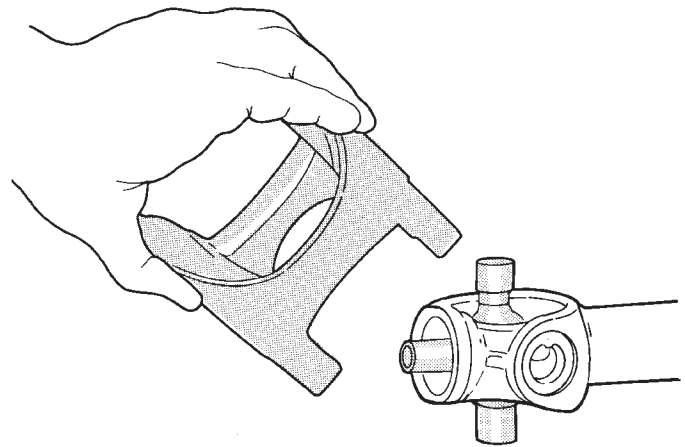


Fig. 28 Install Link Yoke

(9) Install the centering kit assembly inside the link yoke making sure the spring is properly positioned (Fig. 29).

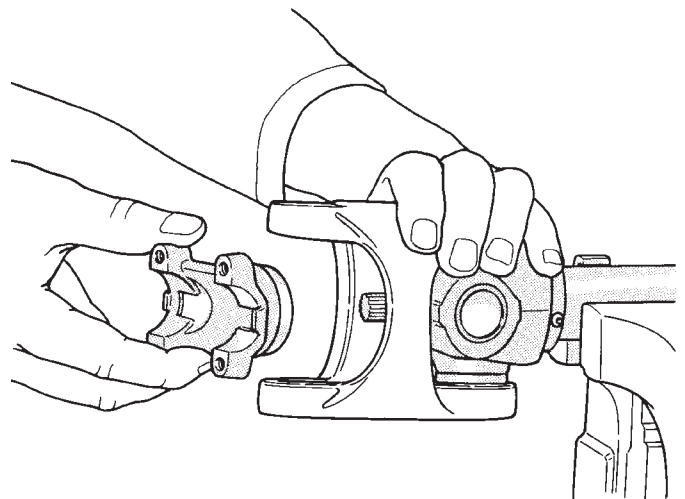
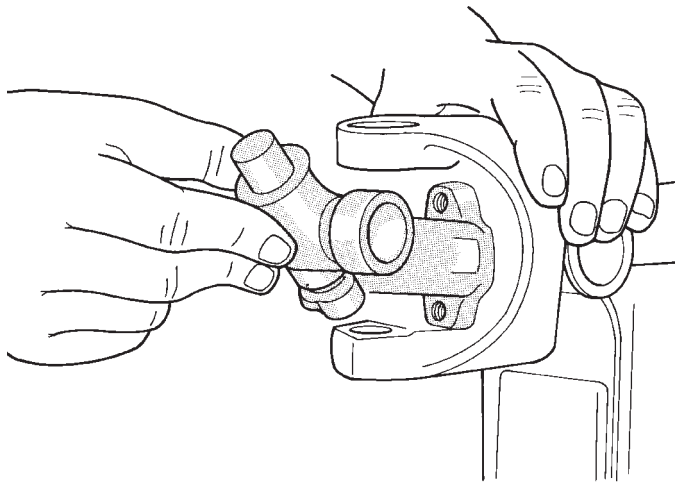


Fig. 29 Install Centering Kit

DISASSEMBLY AND ASSEMBLY (Continued)

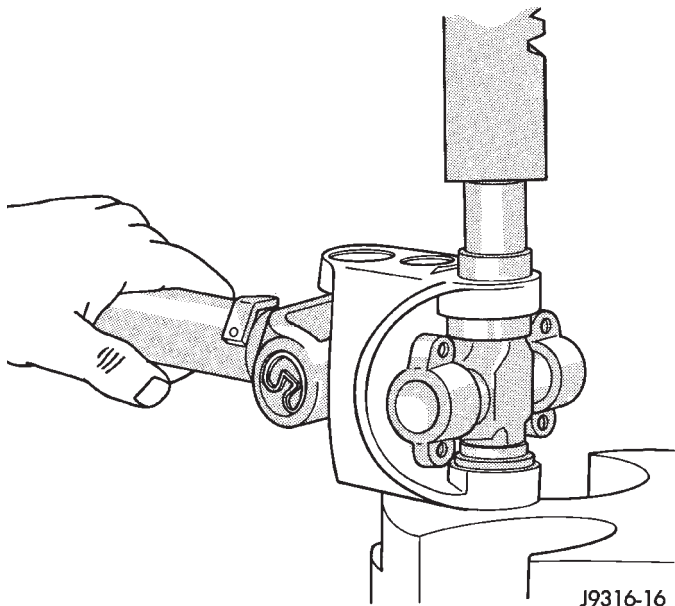
(10) Place two bearing caps on opposite trunnions of the remaining cross. Fit the open trunnions into the link yoke bores and the bearing caps into the centering kit (Fig. 30).



J9316-15

Fig. 30 Install Remaining Cross

(11) Press the remaining two bearing caps into place and install snap rings (Fig. 31).



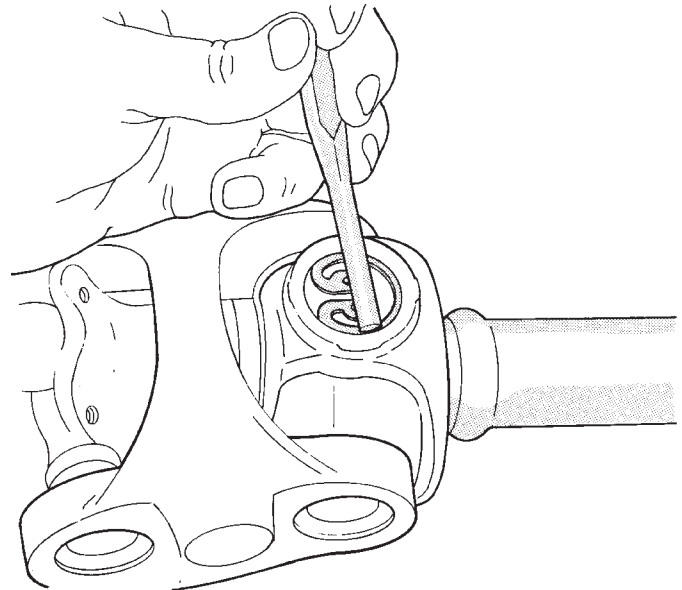
J9316-16

Fig. 31 Press In Bearing Cap

(12) Tap the snap rings to allow them to seat into the grooves (Fig. 32).

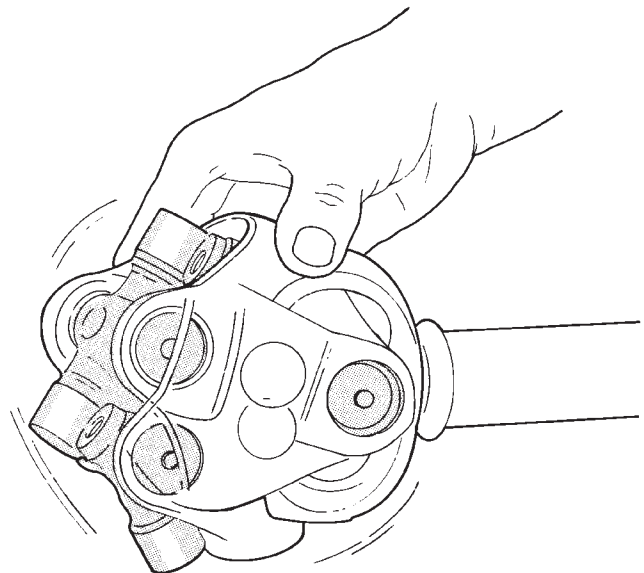
(13) Check for proper assembly. Flex the joint beyond center, it should snap over-center in both directions when correctly assembled (Fig. 33).

(14) Install the propeller shaft.



J9316-17

Fig. 32 Seat Snap Rings In Groove



J9316-18

Fig. 33 Check Assembly

CLEANING AND INSPECTION

SINGLE AND DOUBLE CARDAN JOINT

- (1) Clean all the universal joint yoke bores with cleaning solvent and a wire brush.
- (2) Inspect the yokes for distortion, cracks, and worn bearing cap bores.

ADJUSTMENTS

FRONT PROPELLER SHAFT MEASUREMENT

NOTE: A propeller shaft that has been in use for a long period of time cannot be adjusted. If the length of the propeller is incorrect and causing vibration, replace the propeller shaft.

This measurement is only necessary for the CV style propeller shaft and is to be taken with the shaft installed and the vehicle at proper ride height.

- (1) Place vehicle on floor or drive-on hoist with full weight of vehicle on suspension.
- (2) Measure the distance from the face of the CV joint cup to the end of the CV joint boot (Fig. 34).

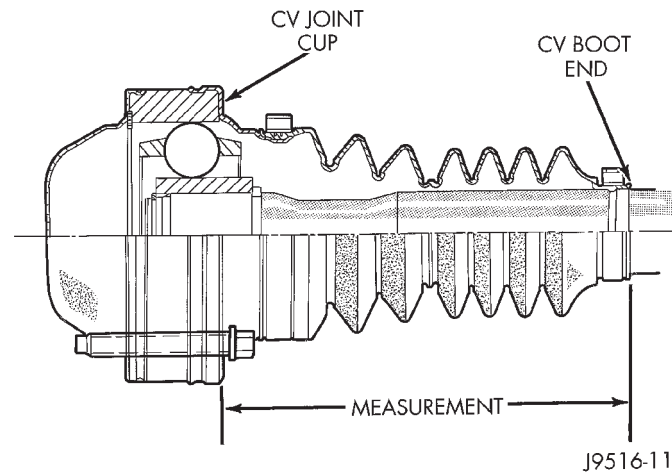


Fig. 34 Measurement

- (3) Loosen the lock nut and adjust the distance by moving the end of the shaft in or out of the other end.
- (4) When the shaft is adjusted to the correct length of 142.7 mm (5.61 in.), tighten the lock-nut (Fig. 35) to 115 N·m (85 ft. lbs.).

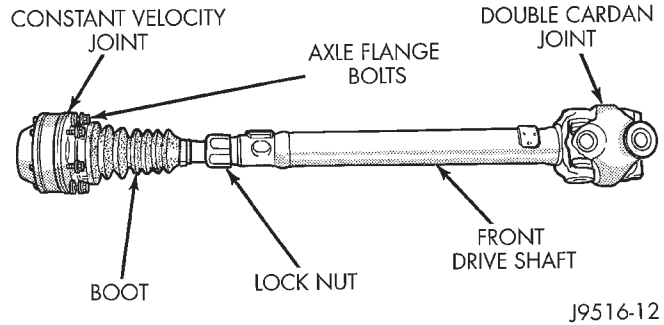


Fig. 35 Lock-nut

AXLE PINION ANGLE ADJUSTMENT

The pinion angle of the front axle can be adjusted by the use of adjustment cams in the lower suspension arms (Fig. 36). The primary function for the cams is to adjust the caster angle for the alignment of the front suspension. When using the cams to adjust the pinion angle, make sure that both cams are moved equally. After the pinion angle is adjusted, the front suspension alignment should be checked to ensure that side-to-side caster angles variance is within the acceptable range. Having the correct pinion angle does not have priority over having the preferred caster angle.

A cam kit is available to be installed in the rear axle lower suspension arms in order to provide adjustability of the pinion angle. Follow the procedures supplied with the kit in order to ensure a safe installation.

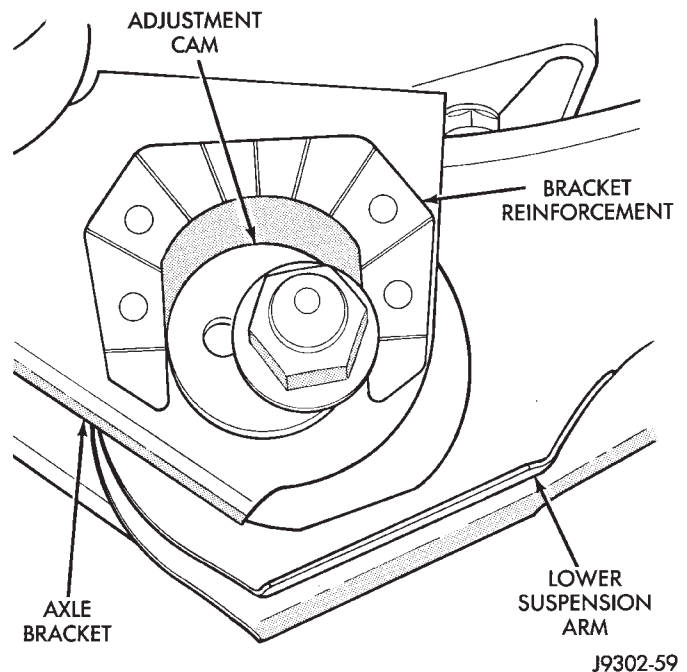


Fig. 36 Adjustment Cam

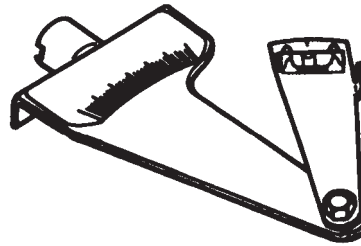
SPECIFICATIONS

TORQUE

DESCRIPTION	TORQUE
Front Propeller Shaft	
Bolts, Rear Yoke27 N·m (20 ft. lbs.)
Bolts, Front Yoke41 N·m (30 ft. lbs.)
Nut, Lock115 N·m (85 ft. lbs.)
Rear Propeller Shaft	
Bolts, Rear Yoke19 N·m (14 ft. lbs.)

SPECIAL TOOLS

PROPELLER SHAFT



Inclinometer—7663

181 FBI AXLE

INDEX

	page		page
GENERAL INFORMATION		DIFFERENTIAL	31
181 FBI AXLE	16	DRIVE AXLE ASSEMBLY	21
LUBRICANT SPECIFICATIONS	16	HUB BEARING AND AXLE SHAFT	28
DESCRIPTION AND OPERATION		PINION GEAR	34
STANDARD DIFFERENTIAL	17	PINION SHAFT SEAL	24
DIAGNOSIS AND TESTING		RING GEAR	38
BEARING NOISE	18	STEERING KNUCKLE AND BALL STUDS	30
DRIVELINE SNAP	18	DISASSEMBLY AND ASSEMBLY	
FRONT AXLES	19	FINAL ASSEMBLY	39
GEAR NOISE	17	STANDARD DIFFERENTIAL	39
GENERAL INFORMATION	17	CLEANING AND INSPECTION	
LOW SPEED KNOCK	18	AXLE COMPONENTS	40
VIBRATION	18	CARDAN U-JOINT	40
SERVICE PROCEDURES		ADJUSTMENTS	
LUBRICANT CHANGE	21	DIFFERENTIAL BEARING PRELOAD AND	
REMOVAL AND INSTALLATION		GEAR BACKLASH	43
AXLE BUSHING REPLACEMENT	31	GEAR CONTACT PATTERN ANALYSIS	46
AXLE CONSTANT-VELOCITY (C/V) JOINT		PINION GEAR DEPTH	40
BOOT	23	SPECIFICATIONS	
AXLE SHAFT OIL SEAL	34	181 FBI AXLE	48
AXLE SHAFT-CARDAN U-JOINT	22	181 FBI AXLE	48
COLLAPSIBLE SPACER	25	SPECIAL TOOLS	
DIFFERENTIAL SIDE BEARINGS	33	181 FBI AXLE	48

GENERAL INFORMATION

181 FBI AXLE

The 181 Front Beam-design Iron (FBI) axle consists of a cast iron differential housing with axle shaft tubes extending from either side. The tubes are pressed into the differential housing and welded.

The integral type housing, hypoid gear design has the centerline of the pinion set below the centerline of the ring gear.

The axle has a fitting for a vent hose used to relieve internal pressure caused by lubricant vaporization and internal expansion.

The axles are equipped with semi-floating axle shafts, meaning that loads are supported by the hub bearings. The axle shafts are retained by nuts at the hub bearings. The hub bearings are bolted to the steering knuckle at the outboard end of the axle tube yoke. The hub bearings are serviced as an assembly.

For vehicles with ABS brakes, the ABS wheel speed sensors are attached to the knuckle assemblies. The tone rings for the ABS system are pressed onto the axle shaft. **Do not damage ABS tone wheel or the sensor when removing axle shafts.**

The stamped steel cover provides a means for inspection and servicing the differential.

The 181 FBI axle has the assembly part number and gear ratio listed on a tag. The tag is attached to the housing cover by a cover bolt. Build date identification codes are stamped on the cover side of the axle shaft tube.

The differential case is a one-piece design. The differential pinion mate shaft is retained with a roll pin. Differential bearing preload and ring gear backlash is adjusted by the use of shims (select thickness). The shims are located between the differential bearing cones and case. Pinion bearing preload is set and maintained by the use of a collapsible spacer.

LUBRICANT SPECIFICATIONS

A multi-purpose, hypoid gear lubricant which conforms to the following specifications should be used. Mopar® Hypoid Gear Lubricant conforms to all of these specifications.

- The lubricant should have MIL-L-2105C and API GL 5 quality specifications.
- Lubricant is a thermally stable SAE 80W-90 gear lubricant.

GENERAL INFORMATION (Continued)

• Lubricant for axles intended for heavy-duty or trailer tow use is SAE 75W-140 SYNTHETIC gear lubricant.

The 181 FBI axle lubricant capacity is 1.2 L (2.5 pts.).

CAUTION: If axle is submerged in water, lubricant must be replaced immediately to avoid possible premature axle failure.

DESCRIPTION AND OPERATION

STANDARD DIFFERENTIAL

The differential gear system divides the torque between the axle shafts. It allows the axle shafts to rotate at different speeds when turning corners.

Each differential side gear is splined to an axle shaft. The pinion gears are mounted on a pinion mate shaft and are free to rotate on the shaft. The pinion gear is fitted in a bore in the differential case and is positioned at a right angle to the axle shafts.

In operation, power flow occurs as follows:

- The pinion gear rotates the ring gear
- The ring gear (bolted to the differential case) rotates the case
- The differential pinion gears (mounted on the pinion mate shaft in the case) rotate the side gears
- The side gears (splined to the axle shafts) rotate the shafts

During straight-ahead driving, the differential pinion gears do not rotate on the pinion mate shaft. This occurs because input torque applied to the gears is divided and distributed equally between the two side gears. As a result, the pinion gears revolve with the pinion mate shaft but do not rotate around it (Fig. 1).

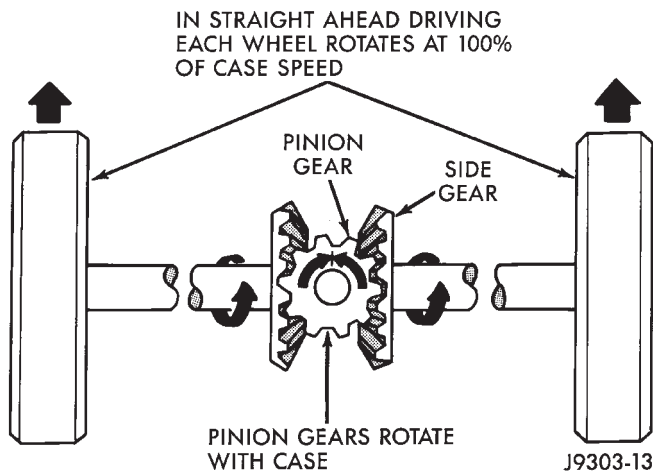


Fig. 1 Differential Operation—Straight Ahead Driving

When turning corners, the outside wheel must travel a greater distance than the inside wheel to complete a turn. The difference must be compensated

for to prevent the tires from scuffing and skidding through turns. To accomplish this, the differential allows the axle shafts to turn at unequal speeds (Fig. 2). In this instance, the input torque applied to the pinion gears is not divided equally. The pinion gears now rotate around the pinion mate shaft in opposite directions. This allows the side gear and axle shaft attached to the outside wheel to rotate at a faster speed.

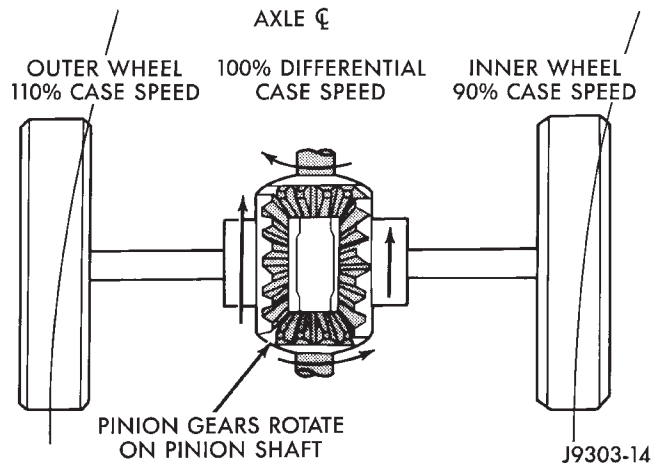


Fig. 2 Differential Operation—On Turns

DIAGNOSIS AND TESTING

GENERAL INFORMATION

Axle bearing problem conditions are usually caused by:

- Insufficient or incorrect lubricant.
- Foreign matter/water contamination.
- Incorrect bearing preload torque adjustment.
- Incorrect backlash.

Axle gear problem conditions are usually the result of:

- Insufficient lubrication.
- Incorrect or contaminated lubricant.
- Overloading (excessive engine torque) or exceeding vehicle weight capacity.
- Incorrect clearance or backlash adjustment.

Axle component breakage is most often the result of:

- Severe overloading.
- Insufficient lubricant.
- Incorrect lubricant.
- Improperly tightened components.

GEAR NOISE

Axle gear noise can be caused by insufficient lubricant, incorrect backlash, tooth contact, or worn/damaged gears.

Gear noise usually happens at a specific speed range. The range is 30 to 40 mph, or above 50 mph. The noise can also occur during a specific type of

DIAGNOSIS AND TESTING (Continued)

driving condition. These conditions are acceleration, deceleration, coast, or constant load.

When road testing, accelerate the vehicle to the speed range where the noise is the greatest. Shift out-of-gear and coast through the peak-noise range. If the noise stops or changes greatly:

- Check for insufficient lubricant.
- Incorrect ring gear backlash.
- Gear damage.

Differential side and pinion gears can be checked by turning the vehicle. They usually do not cause noise during straight-ahead driving when the gears are unloaded. The side gears are loaded during vehicle turns. A worn pinion gear mate shaft can also cause a snapping or a knocking noise.

BEARING NOISE

The axle shaft, differential and pinion gear bearings can all produce noise when worn or damaged. Bearing noise can be either a whining, or a growling sound.

Pinion gear bearings have a constant-pitch noise. This noise changes only with vehicle speed. Pinion bearing noise will be higher because it rotates at a faster rate. Drive the vehicle and load the differential. If bearing noise occurs, the rear pinion bearing is the source of the noise. If the bearing noise is heard during a coast, the front pinion bearing is the source.

Worn or damaged differential bearings usually produce a low pitch noise. Differential bearing noise is similar to pinion bearing noise. The pitch of differential bearing noise is also constant and varies only with vehicle speed.

Axle shaft bearings produce noise and vibration when worn or damaged. The noise generally changes when the bearings are loaded. Road test the vehicle. Turn the vehicle sharply to the left and to the right. This will load the bearings and change the noise level. Where axle bearing damage is slight, the noise is usually not noticeable at speeds above 30 mph.

LOW SPEED KNOCK

Low speed knock is generally caused by a worn U-joint or by worn side-gear thrust washers. A worn pinion gear shaft bore will also cause low speed knock.

VIBRATION

Vibration at the rear of the vehicle is usually caused by a:

- Damaged drive shaft.
- Missing drive shaft balance weight(s).
- Worn or out-of-balance wheels.
- Loose wheel lug nuts.
- Worn U-joint(s).
- Loose/broken springs.
- Damaged axle shaft bearing(s).
- Loose pinion gear nut.
- Excessive pinion yoke run out.
- Bent axle shaft(s).

Check for loose or damaged front-end components or engine/transmission mounts. These components can contribute to what appears to be a rear-end vibration. Do not overlook engine accessories, brackets and drive belts.

All driveline components should be examined before starting any repair.

Refer to Group 22, Wheels and Tires, for additional vibration information.

DRIVELINE SNAP

A snap or clunk noise when the vehicle is shifted into gear (or the clutch engaged), can be caused by:

- High engine idle speed
- Loose engine/transmission/transfer case mounts
- Worn U-joints
- Loose spring mounts
- Loose pinion gear nut and yoke
- Excessive ring gear backlash
- Excessive side gear/case clearance

The source of a snap or a clunk noise can be determined with the assistance of a helper. Raise the vehicle on a hoist with the wheels free to rotate. Instruct the helper to shift the transmission into gear. Listen for the noise, a mechanics stethoscope is helpful in isolating the source of a noise.

DIAGNOSIS AND TESTING (Continued)

FRONT AXLES

DIAGNOSIS

CONDITION	POSSIBLE CAUSES	CORRECTION
WHEEL NOISE	<ol style="list-style-type: none"> 1. Wheel loose. 2. Faulty, brinelled wheel bearing. 	<ol style="list-style-type: none"> 1. Tighten loose nuts. 2. Faulty or brinelled bearings must be replaced.
AXLE SHAFT NOISE	<ol style="list-style-type: none"> 1. Misaligned axle shaft tube. 2. Bent or sprung axle shaft. 3. End play in drive pinion bearings. 4. Excessive gear backlash between ring gear and pinion gear. 5. Improper adjustment of drive pinion gear shaft bearings. 6. Loose drive pinion gearshaft yoke nut. 7. Improper wheel bearing adjustment. 8. Scuffed gear tooth contact surfaces. 	<ol style="list-style-type: none"> 1. Inspect axle shaft tube alignment. Correct as necessary. 2. Replace bent or sprung axle shaft. 3. Refer to Drive Pinion Bearing Pre-Load Adjustment. 4. Check adjustment of ring gear backlash and pinion gear. Correct as necessary. 5. Adjust drive pinion shaft bearings. 6. Tighten drive pinion gearshaft yoke nut with specified torque. 7. Readjust as necessary. 8. If necessary, replace scuffed gears.
AXLE SHAFT BROKE	<ol style="list-style-type: none"> 1. Misaligned axle shaft tube. 2. Vehicle overloaded. 3. Erratic clutch operation. 4. Grabbing clutch. 	<ol style="list-style-type: none"> 1. Replace broken axle shaft after correcting axle shaft tube alignment. 2. Replace broken axle shaft. Avoid excessive weight on vehicle. 3. Replace broken axle shaft after inspecting for other possible causes. Avoid erratic use of clutch. 4. Replace broken axle shaft. Inspect clutch and make necessary repairs or adjustments.
DIFFERENTIAL CASE CRACKED	<ol style="list-style-type: none"> 1. Improper adjustment of differential bearings. 2. Excessive ring gear backlash. 3. Vehicle overloaded. 4. Erratic clutch operation. 	<ol style="list-style-type: none"> 1. Replace cracked case; examine gears and bearings for possible damage. At reassembly, adjust differential bearings properly. 2. Replace cracked case; examine gears and bearings for possible damage. At reassembly, adjust ring gear backlash properly. 3. Replace cracked case; examine gears and bearings for possible damage. Avoid excessive weight on vehicle. 4. Replace cracked case. After inspecting for other possible causes, examine gears and bearings for possible damage. Avoid erratic use of clutch.
DIFFERENTIAL GEARS SCORED	<ol style="list-style-type: none"> 1. Insufficient lubrication. 2. Improper grade of lubricant. 3. Excessive spinning of one wheel/tire. 	<ol style="list-style-type: none"> 1. Replace scored gears. Scoring marks on the drive face of gear teeth or in the bore are caused by instantaneous fusing of the mating surfaces. Scored gears should be replaced. Fill rear differential housing to required capacity with proper lubricant. Refer to Specifications. 2. Replace scored gears. Inspect all gears and bearings for possible damage. Clean and refill differential housing to required capacity with proper lubricant. 3. Replace scored gears. Inspect all gears, pinion bores and shaft for damage. Service as necessary.
LOSS OF LUBRICANT	<ol style="list-style-type: none"> 1. Lubricant level too high. 	<ol style="list-style-type: none"> 1. Drain excess lubricant by removing fill plug and allow lubricant to level at lower edge of fill plug hole.

DIAGNOSIS AND TESTING (Continued)

CONTINUED

CONDITION	POSSIBLE CAUSES	CORRECTION
LOSS OF LUBRICANT	<ol style="list-style-type: none"> 2. Worn axle shaft seals. 3. Cracked differential housing. 4. Worn drive pinion gear shaft seal. 5. Scored and worn yoke. 6. Axle cover not properly sealed. 	<ol style="list-style-type: none"> 2. Replace worn seals. 3. Repair or replace housing as necessary. 4. Replace worn drive pinion gear shaft seal. 5. Replace worn or scored yoke and seal. 6. Remove cover and clean flange and reseal.
AXLE OVERHEATING	<ol style="list-style-type: none"> 1. Lubricant level too low. 2. Incorrect grade of lubricant. 3. Bearings adjusted too tight. 4. Excessive gear wear. 5. Insufficient ring gear backlash. 	<ol style="list-style-type: none"> 1. Refill differential housing. 2. Drain, flush and refill with correct amount of the correct lubricant. 3. Readjust bearings. 4. Inspect gears for excessive wear or scoring. Replace as necessary. 5. Readjust ring gear backlash and inspect gears for possible scoring.
GEAR TEETH BROKE (RING GEAR AND PINION)	<ol style="list-style-type: none"> 1. Overloading. 2. Erratic clutch operation. 3. Ice-spotted pavements. 4. Improper adjustments. 	<ol style="list-style-type: none"> 1. Replace gears. Examine other gears and bearings for possible damage. 2. Replace gears and examine the remaining parts for possible damage. Avoid erratic clutch operation. 3. Replace gears. Examine the remaining parts for possible damage. Replace parts as required. 4. Replace gears. Examine other parts for possible damage. Ensure ring gear backlash is correct.
AXLE NOISE	<ol style="list-style-type: none"> 1. Insufficient lubricant. 2. Improper ring gear and drive pinion gear adjustment. 3. Unmatched ring gear and drive pinion gear. 4. Worn teeth on ring gear or drive pinion gear. 5. Loose drive pinion gear shaft bearings. 6. Loose differential bearings. 7. Misaligned or sprung ring gear. 8. Loose differential bearing cap bolts 	<ol style="list-style-type: none"> 1. Refill axle with correct amount of the proper lubricant. Also inspect for leaks and correct as necessary. 2. Check ring gear and pinion gear teeth contact pattern. 3. Remove unmatched ring gear and drive pinion gear. Replace with matched gear and drive pinion gear set. 4. Check teeth on ring gear and drive pinion gear for correct contact. If necessary, replace with new matched set. 5. Adjust drive pinion gearshaft bearing preload torque. 6. Adjust differential bearing preload torque. 7. Measure ring gear runout. 8. Tighten with specified torque

SERVICE PROCEDURES

LUBRICANT CHANGE

- (1) Raise and support the vehicle.
- (2) Remove the lubricant fill hole plug from the differential housing cover.
- (3) Remove the differential housing cover and drain the lubricant from the housing.
- (4) Clean the housing cavity with a flushing oil, light engine oil or lint free cloth. **Do not use water, steam, kerosene or gasoline for cleaning.**
- (5) Remove the sealant from the housing and cover surfaces. Use solvent to clean the mating surfaces.
- (6) Apply a bead of Mopar® Silicone Rubber Sealant, or equivalent, to the housing cover (Fig. 3).

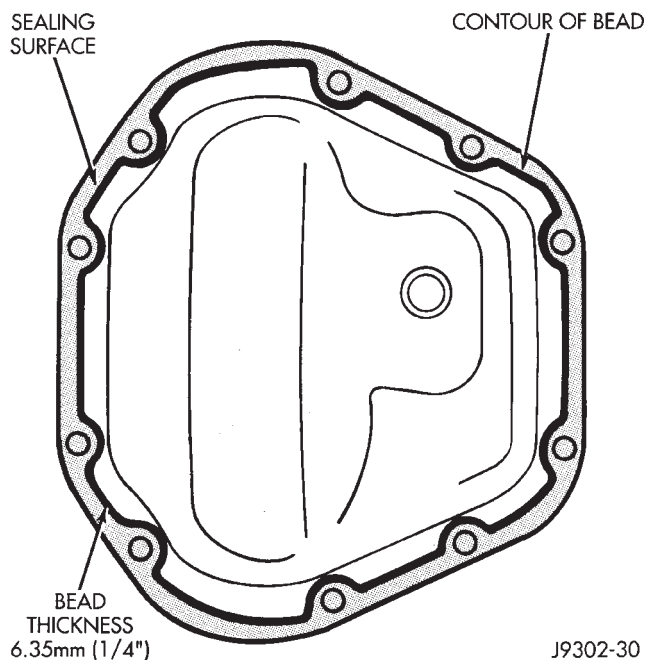


Fig. 3 Typical Housing Cover With Sealant

Install the housing cover within 5 minutes after applying the sealant.

- (7) Install the cover and any identification tag. Tighten the cover bolts in a criss-cross pattern to 41 N·m (30 ft. lbs.) torque.
- (8) Refill the differential with Mopar® Hypoid Gear Lubricant, or equivalent, to bottom of the fill plug hole. Refer to the Lubricant Specifications in this group for the quantity necessary.
- (9) Install the fill hole plug and lower the vehicle. Tighten fill plug to 34 N·m (25 ft. lbs.).

REMOVAL AND INSTALLATION

DRIVE AXLE ASSEMBLY

REMOVAL

- (1) Raise and support the vehicle.
- (2) Position a suitable lifting device under the axle.
- (3) Secure axle to device.
- (4) Remove the wheels and tires.
- (5) Remove the brake rotors and calipers from the axle. Refer to Group 5, Brakes, for proper procedures.
- (6) Disconnect the wheel sensor wiring harness from the vehicle wiring harness, if necessary.
- (7) Disconnect the vent hose from the axle shaft tube.
- (8) Mark the propeller shaft and yoke, or pinion flange, for installation alignment reference.
- (9) Remove propeller shaft.
- (10) Disconnect stabilizer bar links at the axle.
- (11) Disconnect shock absorbers from axle brackets.
- (12) Disconnect track bar.
- (13) Disconnect the tie rod and drag link from the steering knuckle. Refer to Group 2, Suspension, for proper procedures.
- (14) Disconnect the steering damper from the axle bracket.
- (15) Disconnect the upper and lower suspension arms from the axle brackets.
- (16) Lower the lifting device enough to remove the axle. The coil springs will drop with the axle.
- (17) Remove the coil springs from the axle.

INSTALLATION

CAUTION: The weight of the vehicle must be supported by the springs before suspension arms and track bar fasteners can be tightened. If the springs are not at their normal ride position, ride height and handling could be affected.

- (1) Install the springs and retainer clips. Tighten the retainer bolts to 21 N·m (16 ft. lbs.) torque.
- (2) Support the axle on a suitable lifting device and position axle under the vehicle.
- (3) Raise the axle and align it with the spring pads.
- (4) Position the upper and lower suspension arms in the axle brackets. Loosely install bolts and nuts to hold suspension arms to the axle brackets.
- (5) Connect the vent hose to the axle shaft tube.
- (6) Connect the track bar to the axle bracket. Loosely install the bolt to hold the track bar to the axle bracket.
- (7) Install the shock absorbers and tighten the bolts to 23 N·m (17 ft. lbs.) torque.

REMOVAL AND INSTALLATION (Continued)

(8) Install the stabilizer bar links to the axle brackets. Tighten the nut to 95 N·m (70 ft. lbs.) torque.

(9) Install the drag link and tie rod to the steering knuckles. Refer to Group 2, Suspension, for proper procedures.

(10) Install the steering damper to the axle bracket and tighten the nut to 75 N·m (55 ft. lbs.) torque.

(11) Install the brake rotors and calipers. Refer to Group 5, Brakes, for the proper procedures.

(12) Connect the wheel speed sensor wiring harness to the vehicle wiring harness, if necessary.

(13) Align the previously made marks on the propeller shaft and the yoke, or pinion flange.

(14) Install the bolts to hold the propeller shaft to the pinion flange, if equipped.

(15) Install the straps and bolts to hold the propeller shaft to the yoke, if equipped.

(16) Check and fill axle lubricant. Refer to the Lubricant Specifications in this group for the quantity necessary.

(17) Install the wheel and tire assemblies.

(18) Remove the lifting device from the axle and lower the vehicle.

(19) Tighten the upper suspension arm nuts to 75 N·m (55 ft. lbs.) torque. Tighten the lower suspension arm nuts to 115 N·m (85 ft. lbs.) torque.

(20) Tighten the track bar bolt at the axle bracket to 100 N·m (74 ft. lbs.) torque.

(21) Check the front wheel alignment.

AXLE SHAFT—CARDAN U-JOINT

Single cardan U-joint components are not serviceable. If defective, they must be replaced as a unit. If the bearings, seals, spider, or bearing caps are damaged or worn, replace the complete U-joint.

REMOVAL

CAUTION: Clamp only the narrow forged portion of the yoke in the vise. Also, to avoid distorting the yoke, do not over tighten the vise jaws.

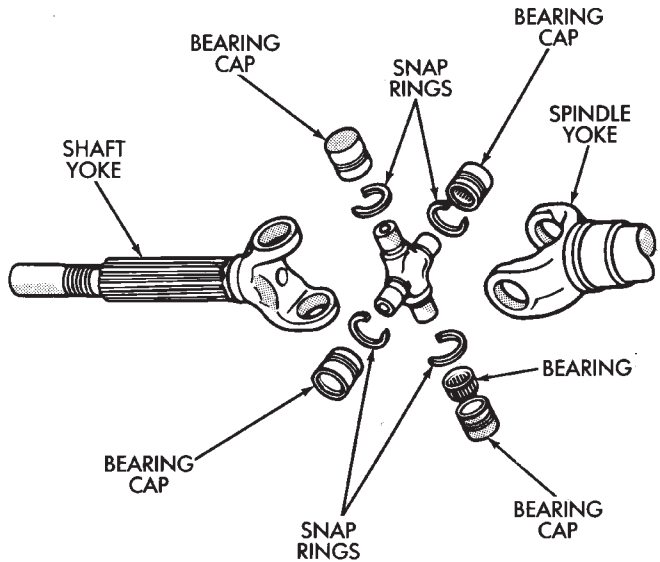
(1) Remove axle shaft.

(2) Remove the bearing cap retaining snap rings (Fig. 4).

It can be helpful to saturate the bearing caps with penetrating oil prior to removal.

(3) Locate a socket where the inside diameter is larger in diameter than the bearing cap. Place the socket (receiver) against the yoke and around the perimeter of the bearing cap to be removed.

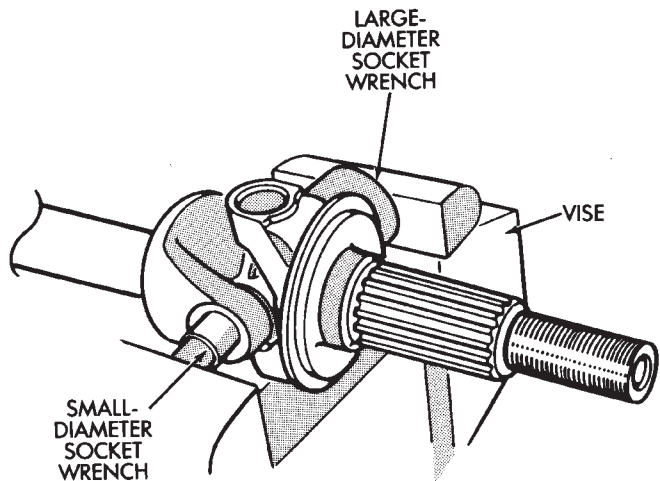
(4) Locate a socket where the outside diameter is smaller in diameter than the bearing cap. Place the socket (driver) against the opposite bearing cap.



J8902-15

Fig. 4 Axle Shaft Outer U-Joint

(5) Position the yoke with the sockets in a vise (Fig. 5).



J8902-16

Fig. 5 Yoke Bearing Cap Removal

(6) Compress the vise jaws to force the bearing cap into the larger socket (receiver).

(7) Release the vise jaws. Remove the sockets and bearing cap that was partially forced out of the yoke.

(8) Repeat the above procedure for the remaining bearing cap.

(9) Remove the remaining bearing cap, bearings, seals and spider from the propeller shaft yoke.

REMOVAL AND INSTALLATION (Continued)

INSTALLATION

- (1) Pack the bearing caps 1/3 full of wheel bearing lubricant. Apply extreme pressure (EP), lithium-base lubricant to aid in installation.
- (2) Position the spider in the yoke. Insert the seals and bearings. Tap the bearing caps into the yoke bores far enough to hold the spider in position.
- (3) Place the socket (driver) against one bearing cap. Position the yoke with the socket wrench in a vise.
- (4) Compress the vise to force the bearing caps into the yoke. Force the caps enough to install the retaining clips.
- (5) Install the bearing cap retaining clips.
- (6) Install axle shaft.

AXLE CONSTANT-VELOCITY (C/V) JOINT BOOT

The only service procedure to be performed on the axle C/V joint, is the replacement of the joint seal boot. If any failure of internal axle shaft components is diagnosed during a vehicle road test, the axle shaft must be replaced as an assembly.

REMOVAL

- (1) Remove axle shaft.
- (2) Remove large boot clamp retaining C/V joint sealing boot, to C/V joint housing and discard.
- (3) Remove small clamp that retains outer C/V joint sealing boot to axle shaft and discard (Fig. 6).
- (4) Remove sealing boot from outer C/V joint housing and slide it down and off the axle shaft.

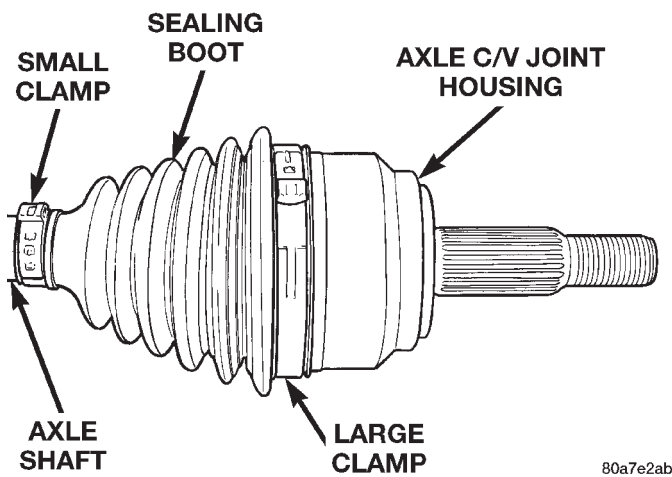


Fig. 6 Outer C/V Joint Seal Boot Clamps

(5) Thoroughly clean and inspect axle C/V joint assembly and axle shaft for any signs of excessive wear. **If any parts show signs of excessive wear, the axle shaft assembly will require replacement. Component parts of these axle shaft assemblies are not serviceable.**

INSTALLATION

- (1) Slide new sealing boot large clamp over axle shaft and onto C/V joint.
- (2) Slide the axle C/V joint sealing boot onto the axle shaft.
- (3) Distribute 1/2 the amount of grease provided in seal boot service package (DO NOT USE ANY OTHER TYPE OF GREASE) into axle C/V joint assembly housing. Put the remaining amount into the sealing boot.
- (4) Install axle C/V joint boot small clamp evenly on sealing boot.
- (5) Position axle C/V joint boot into retaining groove in axle C/V joint housing. Then, install large retaining clamp evenly on sealing boot.
- (6) Clamp small sealing boot clamp onto axle shaft using Crimper C-4975-A. Place crimping tool C-4975-A over bridge of clamp (Fig. 7).
- (7) Tighten nut on crimping tool C-4975-A until jaws on tool are closed completely together, face to face (Fig. 8).

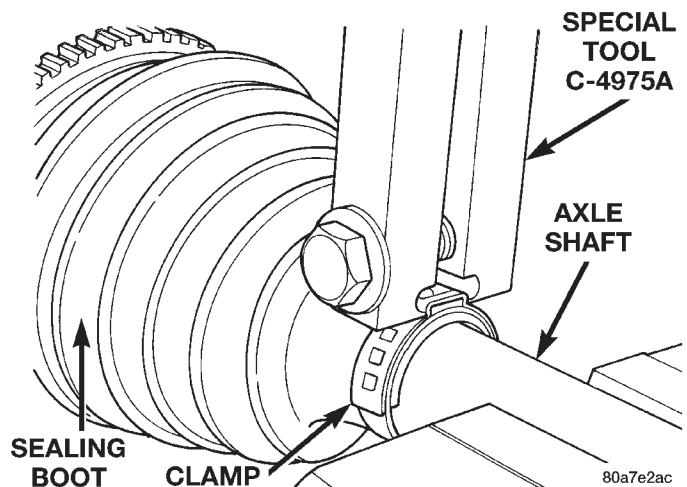


Fig. 7 Crimping Tool Installed On Boot Clamp

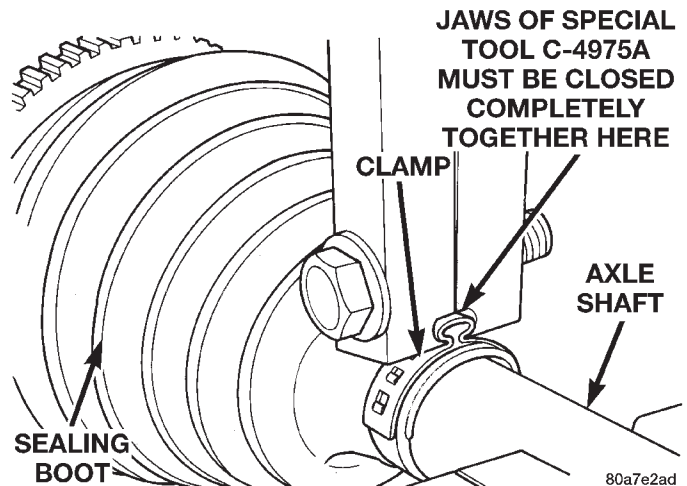


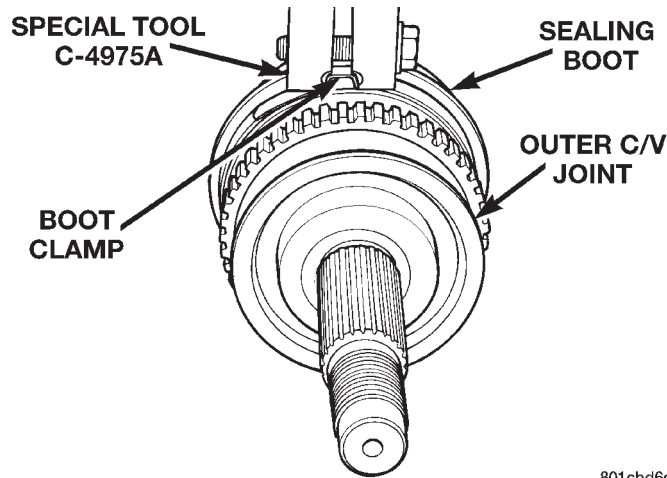
Fig. 8 Sealing Boot Retaining Clamp Installed

REMOVAL AND INSTALLATION (Continued)

CAUTION: Seal must not be dimpled, stretched or out of shape in any way. If seal is NOT shaped correctly, equalize pressure in seal and shape it by hand.

(8) Clamp large sealing boot clamp onto axle shaft using Crimper C-4975-A. Place crimping tool C-4975-A over bridge of clamp (Fig. 9).

(9) Tighten nut on crimping tool C-4975-A until jaws on tool are closed completely together, face to face.



801cbd6d

Fig. 9 Crimping Tool Installed On Large Boot Clamp
PINION SHAFT SEAL

REMOVAL

- (1) Raise and support the vehicle.
- (2) Remove wheel and tire assemblies.
- (3) Remove brake rotors and calipers. Refer to Group 5, Brakes, for proper procedures.
- (4) Mark the propeller shaft and pinion yoke, or pinion flange, for installation reference.
- (5) Remove the propeller shaft from the yoke, or pinion flange.
- (6) Rotate the pinion gear three or four times.
- (7) Measure the amount of torque necessary to rotate the pinion gear with a (in. lbs.) dial-type torque wrench. Record the torque reading for installation reference.
- (8) Using a short piece of pipe and Holder 6958 to hold the pinion yoke, or pinion flange, remove the pinion nut and washer.
- (9) Use Remover C-452 and Wrench C-3281 to remove the pinion yoke, or pinion flange, (Fig. 10).
- (10) Use Remover 7794-A and slide hammer to remove the pinion shaft seal (Fig. 11).

INSTALLATION

- (1) Apply a light coating of gear lubricant on the lip of pinion seal. Install seal with Installer C-3972-A and Handle C-4171 (Fig. 12).

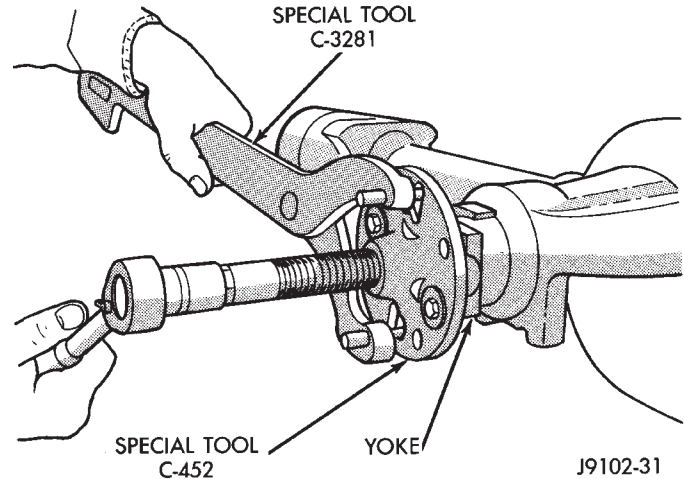


Fig. 10 Pinion Yoke Removal

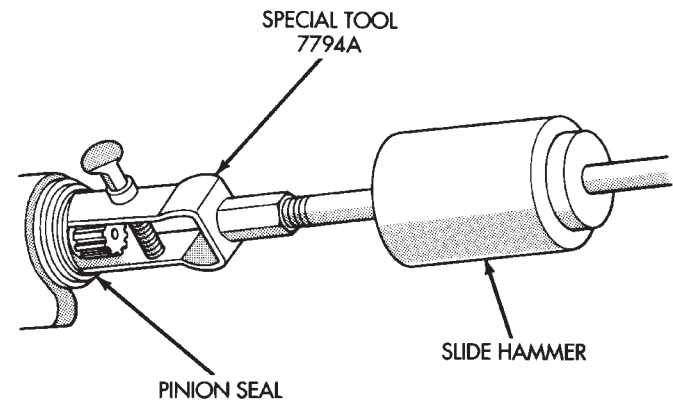


Fig. 11 Seal Removal

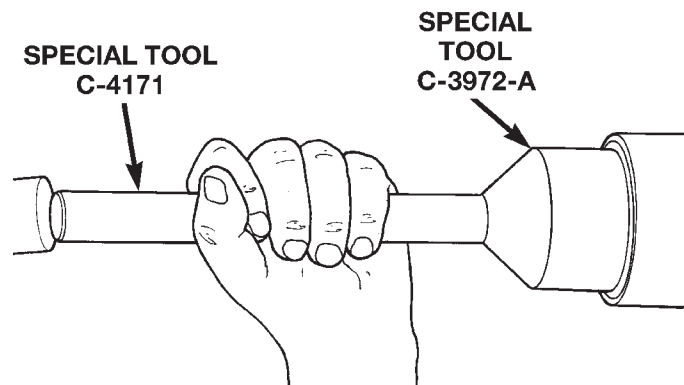


Fig. 12 Pinion Seal Installation

REMOVAL AND INSTALLATION (Continued)

(2) Install yoke, or pinion flange, on the pinion gear with Installer W-162-D, Cup 8109, and Holder 6958 (Fig. 13).

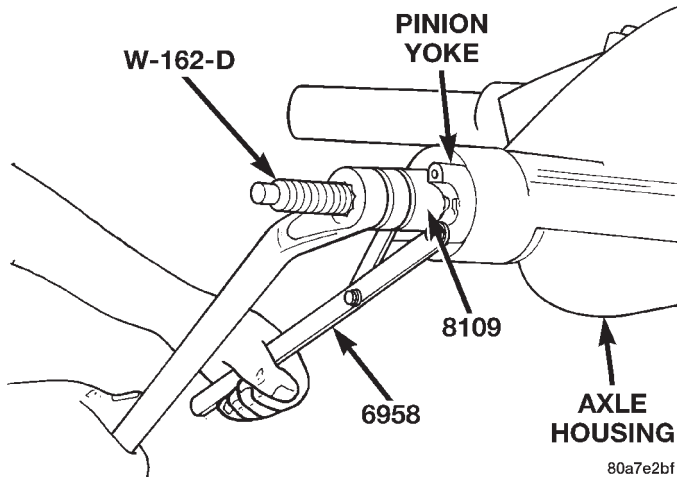


Fig. 13 Pinion Yoke Installation

CAUTION: Do not exceed the minimum tightening torque when installing the pinion yoke retaining nut at this point. Damage to collapsible spacer or bearings may result.

(3) Install the pinion washer and a new nut on the pinion gear. **Tighten the nut only enough to remove the shaft end play.**

(4) Rotate the pinion shaft using a (in. lbs.) torque wrench. Rotating torque should be equal to the reading recorded during removal, plus an additional 0.56 N·m (5 in. lbs.) (Fig. 14).

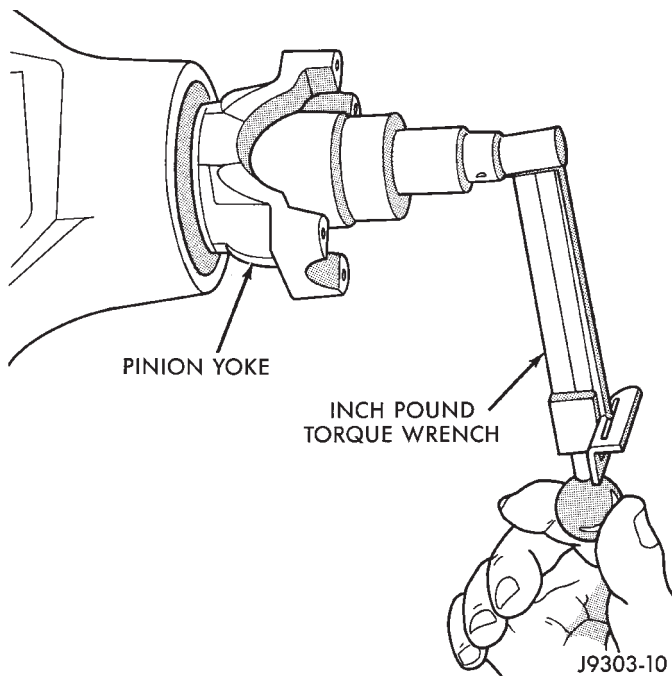


Fig. 14 Check Pinion Rotation Torque

(5) If the rotating torque is low, use Holder 6958 to hold the pinion yoke (Fig. 15), and tighten the pinion shaft nut in 6.8 N·m (5 ft. lbs.) increments until proper rotating torque is achieved.

CAUTION: If the maximum tightening torque is reached prior to reaching the required rotating torque, the collapsible spacer may have been damaged. Replace the collapsible spacer.

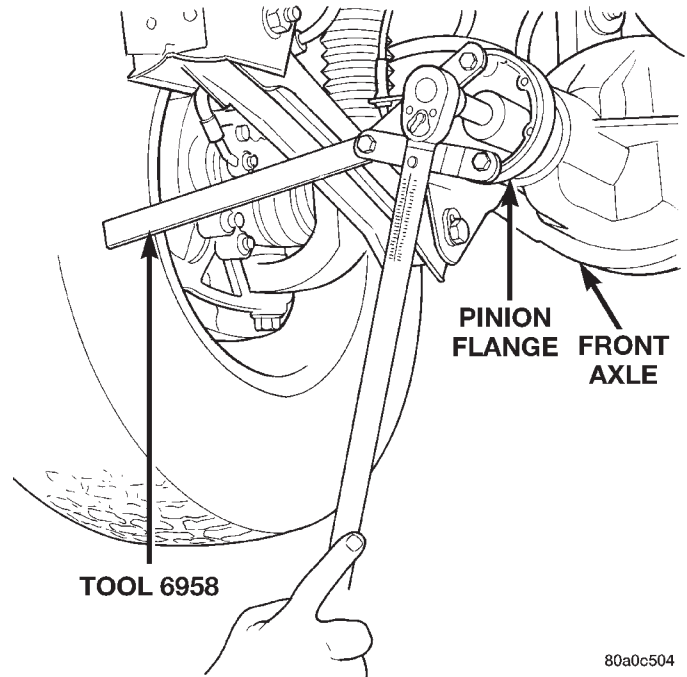


Fig. 15 Tightening Pinion Shaft Nut

(6) Align the installation reference marks on the propeller shaft and yoke, or pinion flange, and install the propeller shaft.

(7) Check and fill the gear lubricant. Refer to the Lubricant Specifications for gear lubricant requirements.

(8) Install the brake rotors and calipers. Refer to Group 5, Brakes, for proper procedures.

(9) Install wheel and tire assemblies.

(10) Lower the vehicle.

COLLAPSIBLE SPACER

REMOVAL W/PINION INSTALLED

- (1) Raise and support the vehicle.
- (2) Remove wheel and tire assemblies.
- (3) Remove brake rotors and calipers. Refer to Group 5, Brakes, for proper procedures.
- (4) Mark the propeller shaft and pinion yoke, or pinion flange, for installation reference.
- (5) Remove the propeller shaft from the yoke, or pinion flange.
- (6) Rotate the pinion gear three or four times.

REMOVAL AND INSTALLATION (Continued)

(7) Measure the amount of torque necessary to rotate the pinion gear with a (in. lbs.) dial-type torque wrench. Record the torque reading for installation reference.

(8) Using a short piece of pipe and Holder 6958 to hold the pinion yoke, or pinion flange, remove the pinion nut and washer.

(9) Use Remover C-452 and Wrench C-3281 to remove the pinion yoke, or flange, (Fig. 16).

(10) Use Remover 7794-A and slide hammer to remove the pinion shaft seal (Fig. 17).

(11) Remove the front pinion bearing using a pair of suitable pick tools to pull the bearing straight off the pinion gear shaft. It may be necessary to lightly tap the end of the pinion gear with a rawhide or rubber mallet if the bearing becomes bound on the pinion shaft.

(12) Remove the collapsible spacer.

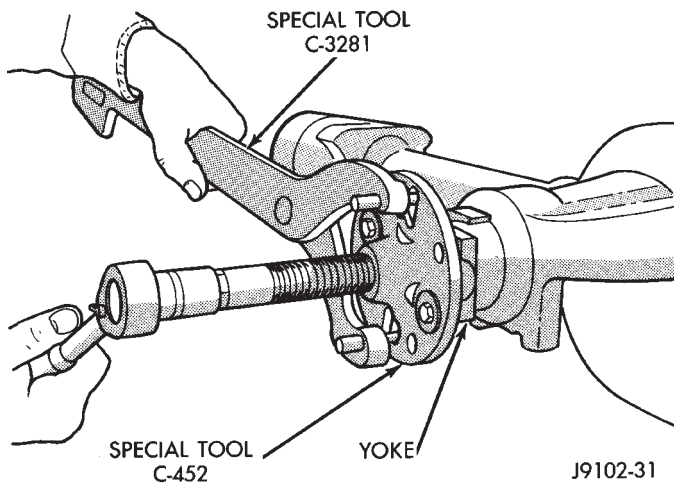


Fig. 16 Pinion Yoke Removal

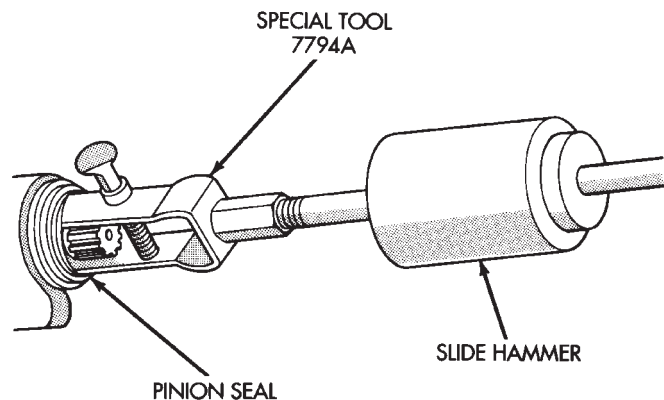


Fig. 17 Seal Removal

REMOVAL W/PINION REMOVED

(1) Raise and support the vehicle.

(2) Remove wheel and tire assemblies.

(3) Remove brake rotors and calipers. Refer to Group 5, Brakes, for proper procedures.

(4) Mark the propeller shaft and pinion yoke, or pinion flange, for installation reference.

(5) Remove the propeller shaft from the yoke, or pinion flange.

(6) Rotate the pinion gear three or four times.

(7) Measure the amount of torque necessary to rotate the pinion gear with a (in. lbs.) dial-type torque wrench. Record the torque reading for installation reference.

(8) Remove differential assembly from axle housing.

(9) Using Holder 6958 to hold yoke, or flange, and a short length of 1 in. pipe, remove the pinion nut and washer.

(10) Using Remover C-452 and Wrench C-3281, remove the pinion yoke, or flange, from pinion shaft (Fig. 16).

(11) Remove the pinion gear from housing (Fig. 18). Catch the pinion with your hand to prevent it from falling and being damaged.

(12) Remove collapsible spacer from pinion shaft.

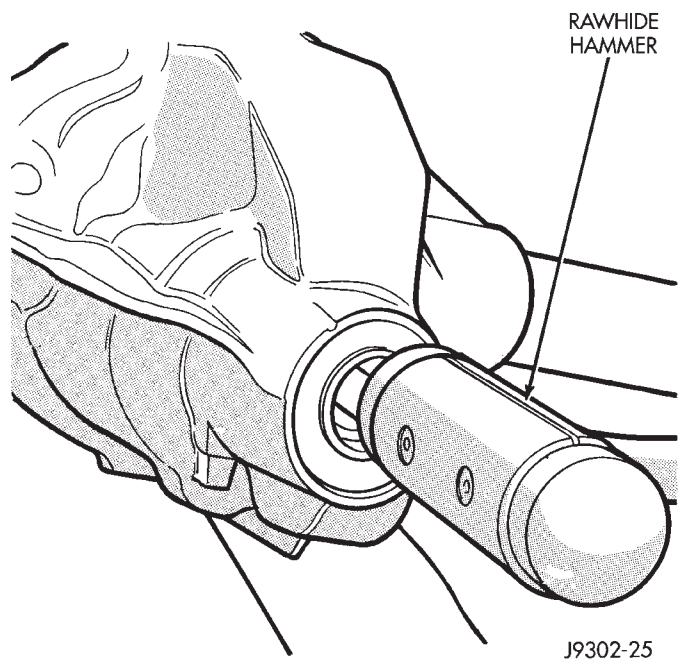


Fig. 18 Remove Pinion Gear

REMOVAL AND INSTALLATION (Continued)

INSTALLATION

- (1) Install a new collapsible preload spacer on pinion shaft (Fig. 19).
- (2) If pinion gear was removed, install pinion gear in housing.

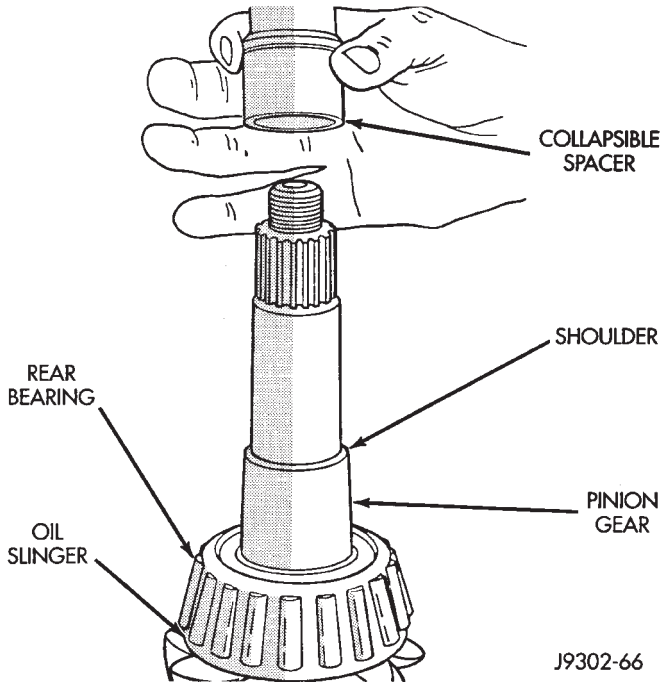


Fig. 19 Collapsible Preload Spacer

- (3) Install pinion front bearing, if necessary.
- (4) Apply a light coating of gear lubricant on the lip of pinion seal. Install seal with Installer C-3972-A and Handle C-4171 (Fig. 20), if necessary.
- (5) Install yoke, or pinion flange, with Installer W-162-D, Cup 8109, and holder 6958 (Fig. 21).
- (6) If the original pinion bearings are being used, install differential assembly and axle shafts, if necessary.

NOTE: If new pinion bearings were installed, do not install the differential assembly and axle shafts until after the pinion bearing preload and rotating torque are set.

- (7) Install the pinion washer and a new nut on the pinion gear. Tighten the nut to 217 N·m (160 ft. lbs.)

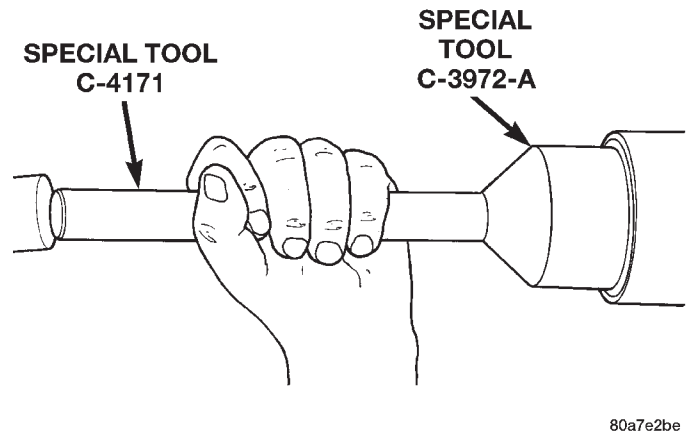


Fig. 20 Pinion Seal Installation

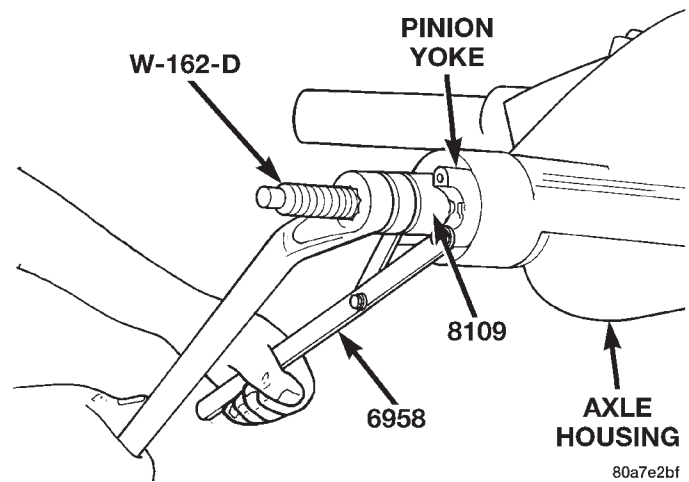


Fig. 21 Pinion Yoke Installation

minimum. **Do not over-tighten.** Maximum torque is 353 N·m (260 ft. lbs.).

CAUTION: Never loosen pinion gear nut to decrease pinion gear bearing rotating torque and never exceed specified preload torque. If preload torque is exceeded a new collapsible spacer must be installed. The torque sequence will then have to be repeated.

NOTE: If the spacer requires more than 353 N·m (260 ft. lbs.) of torque to crush, the collapsible spacer is defective and must be replaced.

REMOVAL AND INSTALLATION (Continued)

(8) Using yoke holder 6958, a short length of 1 in. pipe, and a torque wrench set at 353 N·m (260 ft. lbs.), crush collapsible spacer until bearing end play is taken up (Fig. 22).

(9) Slowly tighten the nut in 6.8 N·m (5 ft. lbs.) increments until the rotating torque is achieved. Measure the rotating torque frequently to avoid over crushing the collapsible spacer (Fig. 23).

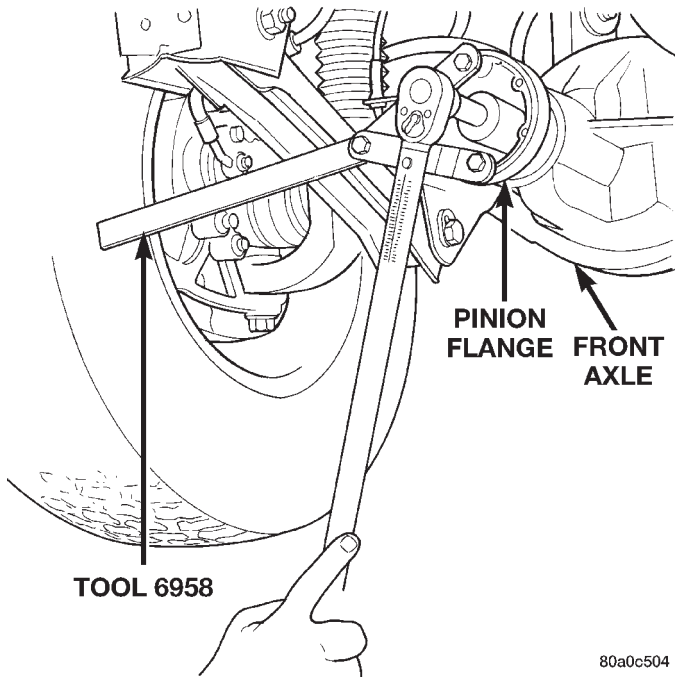


Fig. 22 Tightening Pinion Nut

(10) Check rotating torque with an inch pound torque wrench (Fig. 23). The torque necessary to rotate the pinion gear should be:

- Original Bearings — The reading recorded during removal, plus an additional 0.56 N·m (5 in. lbs.).
- New Bearings — 2 to 5 N·m (15 to 35 in. lbs.).

(11) Install differential assembly and axle shafts, if necessary.

(12) Align marks made previously on yoke, or pinion flange, and propeller shaft and install propeller shaft.

(13) Install brake rotors and calipers. Refer to Group 5, Brakes, for proper procedures.

(14) Add gear lubricant, if necessary. Refer to Lubricant Specifications of this section for lubricant requirements.

(15) Install wheel and tire assemblies.

(16) Lower vehicle.

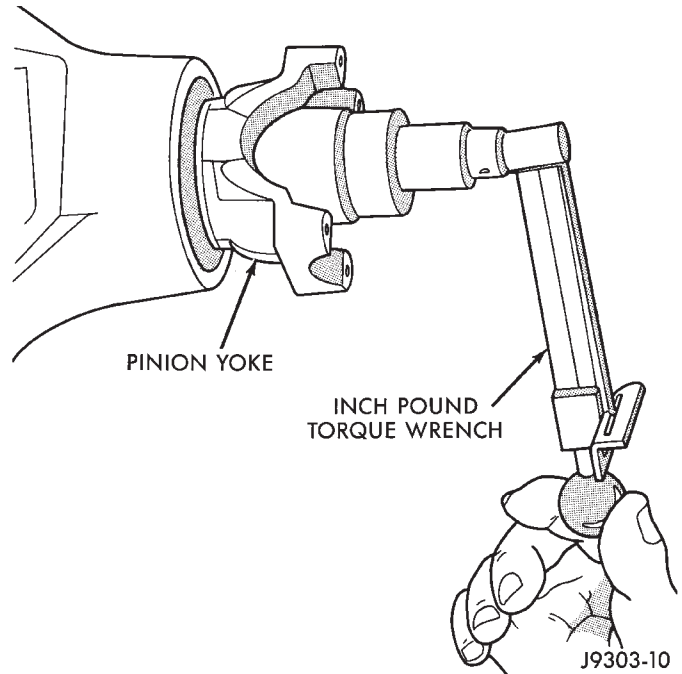


Fig. 23 Check Pinion Gear Rotation Torque—Typical HUB BEARING AND AXLE SHAFT

If the axle shaft and hub bearing are being removed in order to service another component, the axle shaft and hub bearing can be removed as an assembly.

REMOVAL

- (1) Raise and support the vehicle.
- (2) Remove the wheel and tire assembly.
- (3) Remove the brake caliper and rotor. Refer to Group 5, Brakes, for proper procedures.
- (4) Remove ABS wheel speed sensor, if necessary. Refer to Group 5, Brakes, for proper procedures.
- (5) Remove the cotter pin, nut retainer, and axle hub nut (Fig. 24), if necessary.

REMOVAL AND INSTALLATION (Continued)

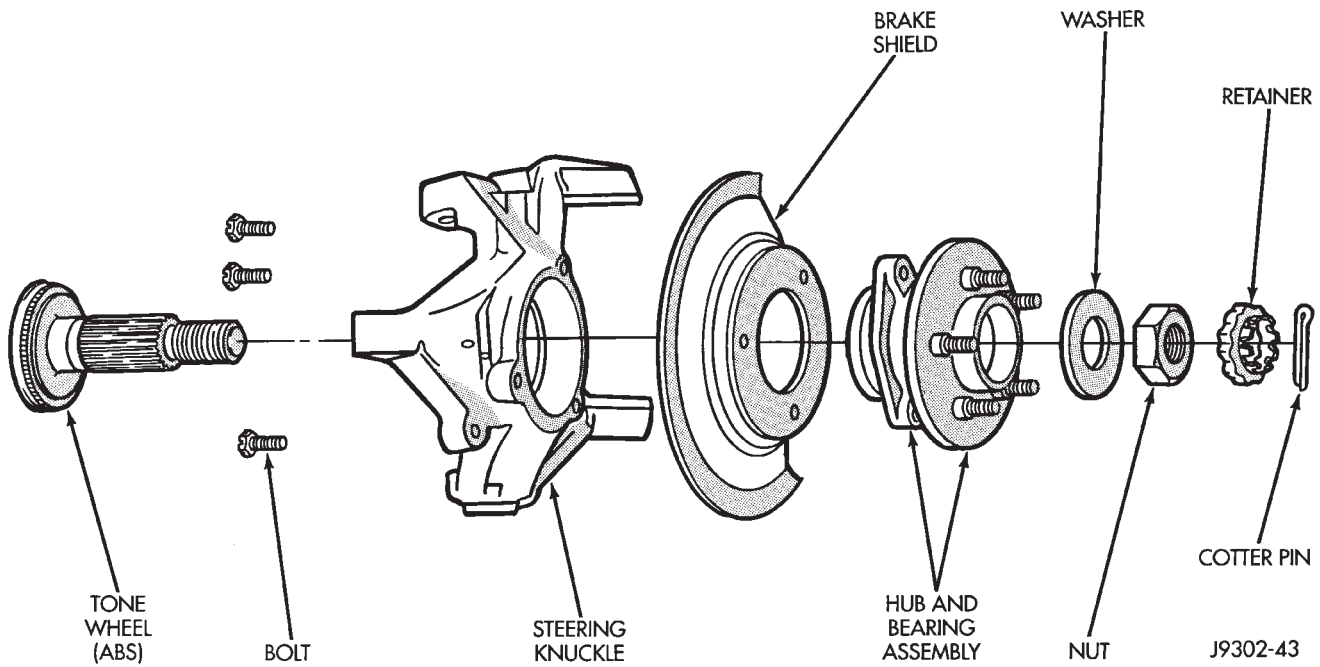


Fig. 24 Hub, Knuckle and Axle Shaft

- (6) Remove the hub to knuckle bolts (Fig. 25).
- (7) Remove the hub from the steering knuckle and axle shaft, if necessary.
- (8) Remove hub bearing and axle shaft assembly (Fig. 26), or axle shaft from axle. **Avoid damaging the axle shaft oil seals in the axle housing.**

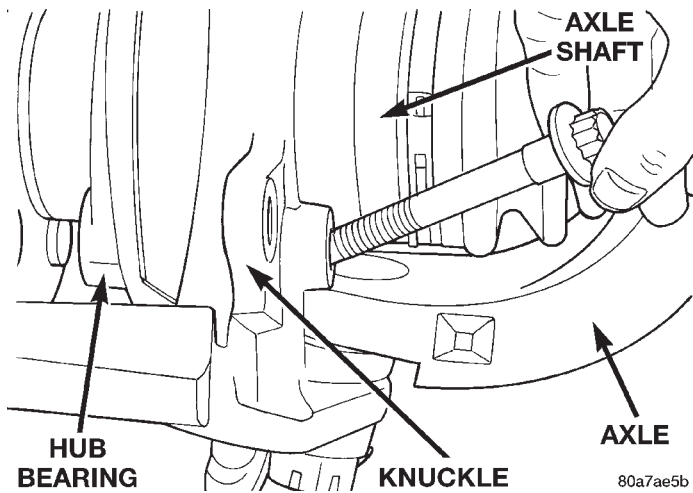


Fig. 25 Hub Bearing Bolts

- (9) Remove the brake rotor shield from the hub bearing or knuckle (Fig. 24).

INSTALLATION

- (1) Thoroughly clean the axle shaft (Fig. 24) and apply a thin film of Mopar® Wheel Bearing Grease, or equivalent, to the shaft splines, seal contact surface, and hub bore.

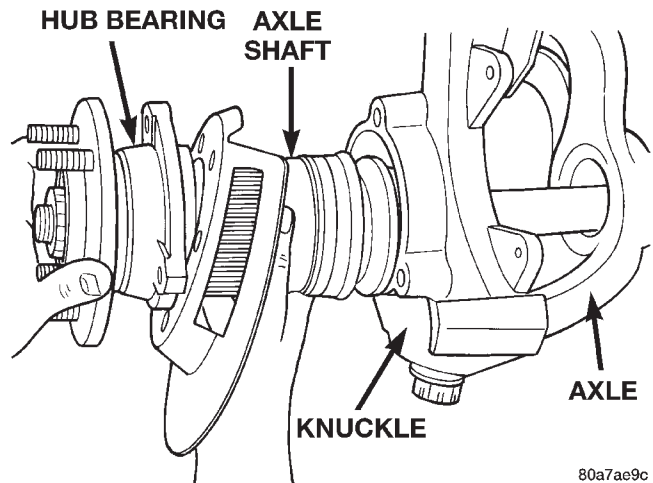


Fig. 26 Hub Bearing and Axle Assembly

- (2) Install the brake rotor shield to the knuckle.
- (3) Install the hub bearing and axle shaft assembly, or axle shaft, into the housing and differential side gears. Avoid damaging the axle shaft oil seals in the axle housing.
- (4) Install the hub bearing, if necessary.
- (5) Install the hub to knuckle bolts and tighten to 102 N·m (75 ft. lbs.) torque.
- (6) Install the hub washer and nut, if necessary. Tighten the hub nut to 237 N·m (175 ft. lbs.) torque. Install the nut retainer and a new cotter pin (Fig. 24).
- (7) Install ABS wheel speed sensor, if necessary. Refer to Group 5, Brakes, for proper procedures.

REMOVAL AND INSTALLATION (Continued)

- (8) Install the brake rotor and caliper. Refer to Group 5, Brakes, for proper procedures.
- (9) Install the wheel and tire assembly.
- (10) Remove support and lower the vehicle.

STEERING KNUCKLE AND BALL STUDS

Ball stud service procedures below require removal of the hub bearing and axle shaft. Removal and installation of upper and lower ball studs require the use of Tool Kit 6289.

KNUCKLE REMOVAL

- (1) Remove hub bearing and axle shaft.
- (2) Disconnect the tie-rod or drag link from the steering knuckle arm. Refer to Group 2, Suspension, for proper procedures.
- (3) Remove the cotter pins from the upper and lower ball studs.
- (4) Remove the upper and lower ball stud nuts.
- (5) Strike the steering knuckle with a brass hammer to loosen knuckle from the ball studs. Remove knuckle from ball studs (Fig. 27).

UPPER BALL STUD REPLACEMENT

- (1) Position tools as shown to remove and install ball stud (Fig. 28).

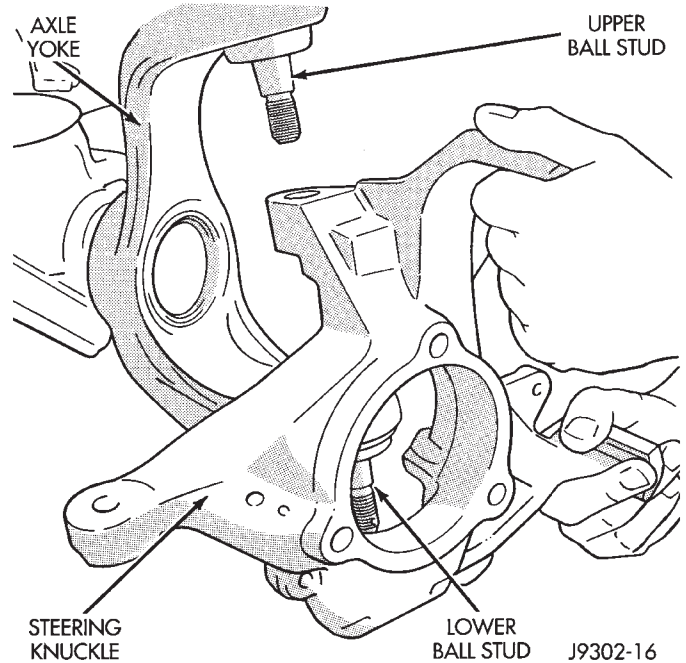


Fig. 27 Steering Knuckle Removal/Installation
LOWER BALL STUD REPLACEMENT

- (1) Position tools as shown to remove and install ball stud (Fig. 29).

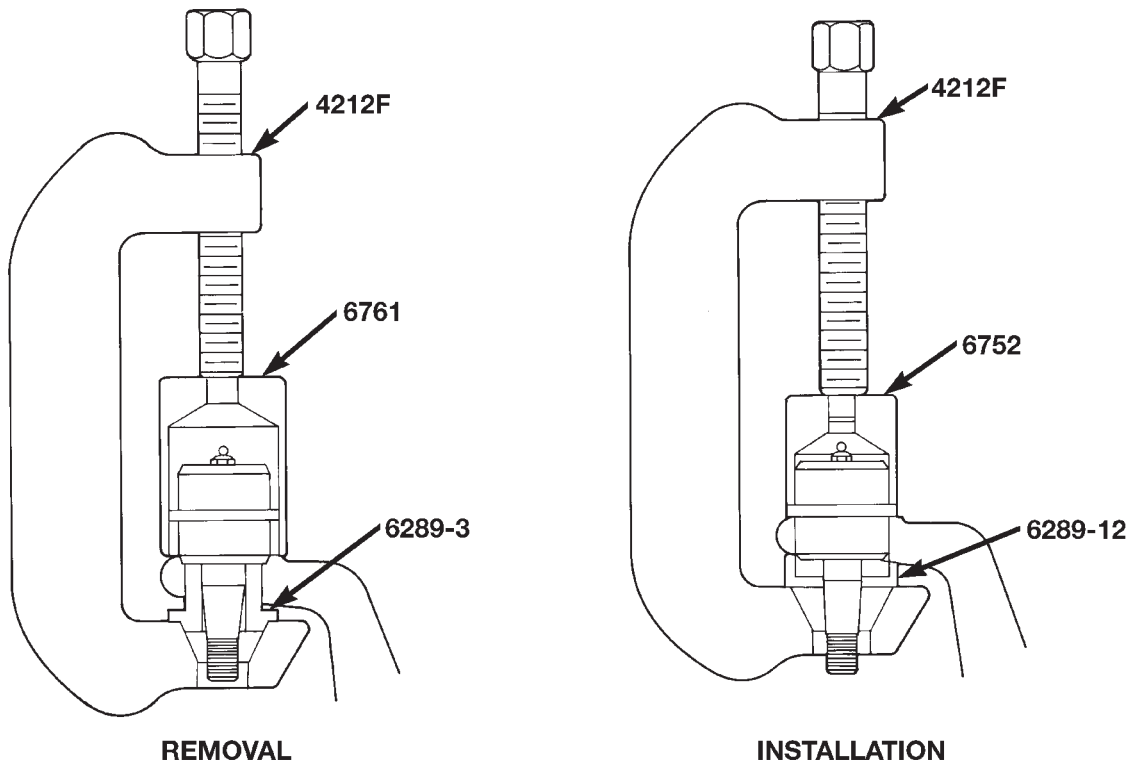
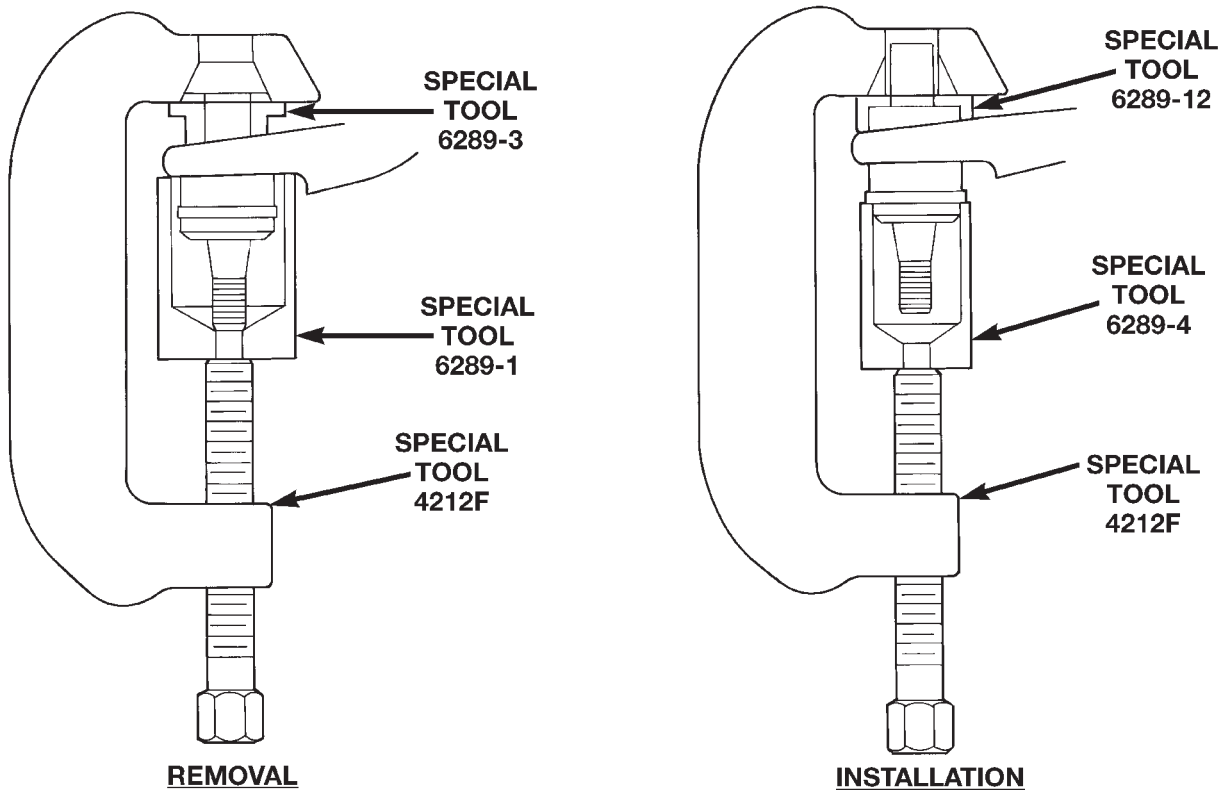


Fig. 28 Upper Ball Stud Remove/Install

REMOVAL AND INSTALLATION (Continued)



80a7e2a8

Fig. 29 Lower Ball Stud Remove/Install

KNUCKLE INSTALLATION

- (1) Position the steering knuckle on the ball studs.
- (2) Install and tighten the bottom retaining nut to 109 N·m (80 ft. lbs.) torque. Install new cotter pin.
- (3) Install and tighten the top retaining nut to 101 N·m (75 ft. lbs.) torque. Install new cotter pin.
- (4) Install the hub bearing and axle shaft.
- (5) Connect the tie-rod or drag link end to the steering knuckle arm. Refer to Group 2, Suspension, for proper procedures.

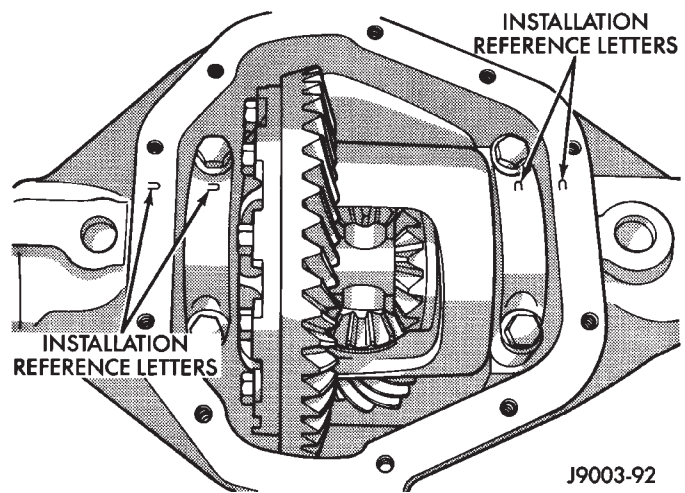
AXLE BUSHING REPLACEMENT

Refer to Group 2, Suspension, for the proper axle bushing procedures.

DIFFERENTIAL

REMOVAL

- (1) Raise and support vehicle.
- (2) Remove the lubricant fill hole plug from the differential housing cover.
- (3) Remove the differential housing cover and allow fluid to drain.
- (4) Remove hub bearings and axle shafts.
- (5) Note the installation reference letters stamped on the bearing caps and housing machined sealing surface (Fig. 30).



J9003-92

Fig. 30 Bearing Cap Identification

- (6) Loosen the differential bearing cap bolts.
- (7) Position Spreader W-129-B, utilizing some items from Adapter Kit 6987, with the tool dowel pins seated in the locating holes (Fig. 31). Install the holddown clamps and tighten the tool turnbuckle finger-tight.
- (8) Install a Guide Pin C-3288-B at the left side of the differential housing. Attach Dial Indicator C-3339 to guide pin. Load the lever adapter against the

REMOVAL AND INSTALLATION (Continued)

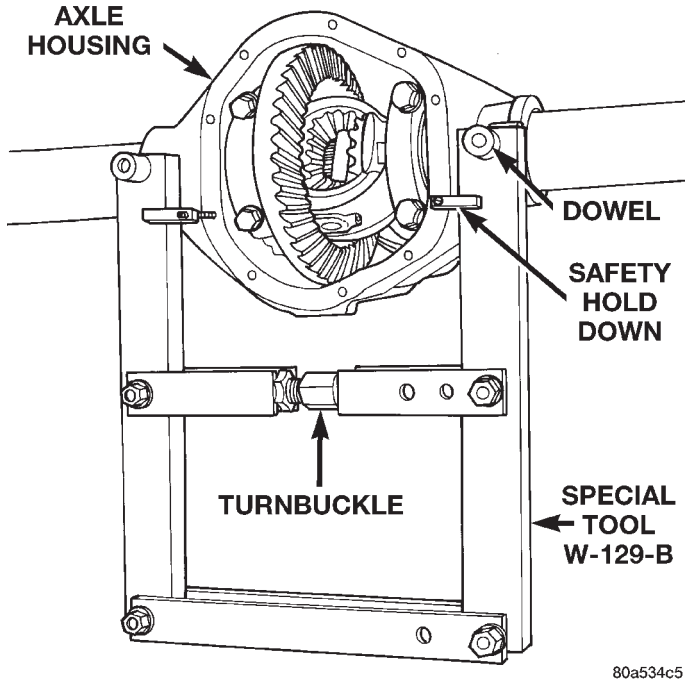


Fig. 31 Install Axle Housing Spreader

opposite side of the housing (Fig. 32) and zero the indicator.

CAUTION: Do not spread over 0.50 mm (0.020 in). If the housing is over-spread, it could be distorted or damaged.

(9) Spread the housing enough to remove the differential case from the housing. Measure the distance with the dial indicator (Fig. 33).

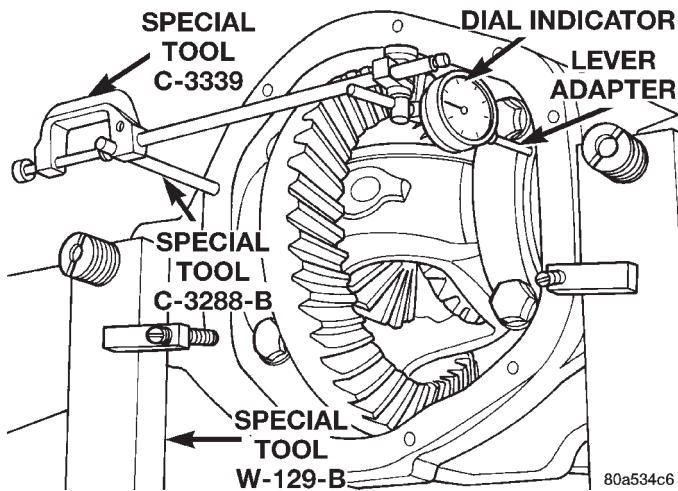


Fig. 32 Install Dial Indicator

(10) Remove the dial indicator.

(11) While holding the differential case in position, remove the differential bearing cap bolts and caps.

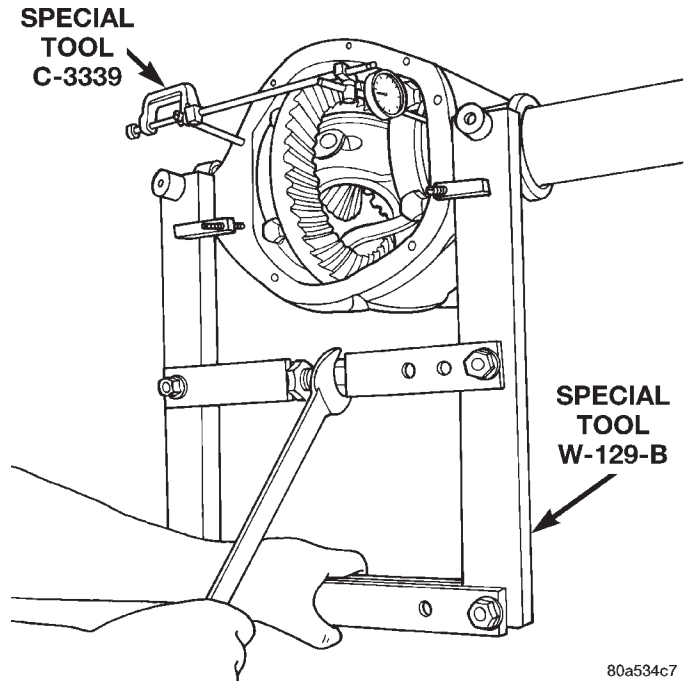


Fig. 33 Spread Axle Housing

(12) Remove the differential from the housing. Ensure that the differential bearing cups remain in position on the differential bearings (Fig. 34).

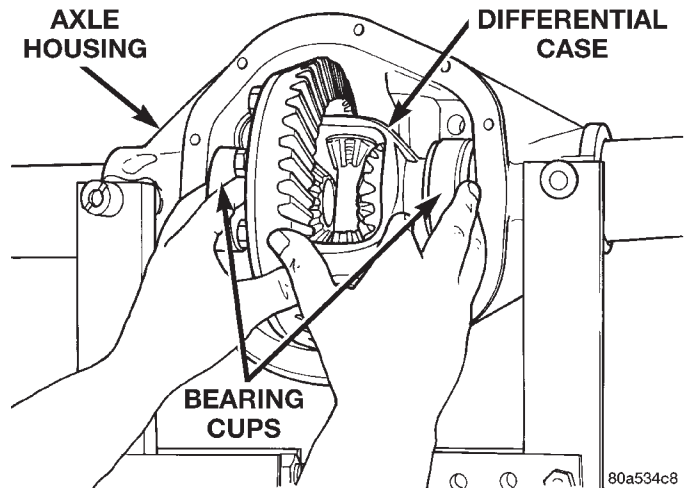


Fig. 34 Differential Case Removal

(13) Mark or tag the differential bearing cups to indicate which side of the differential they were removed from.

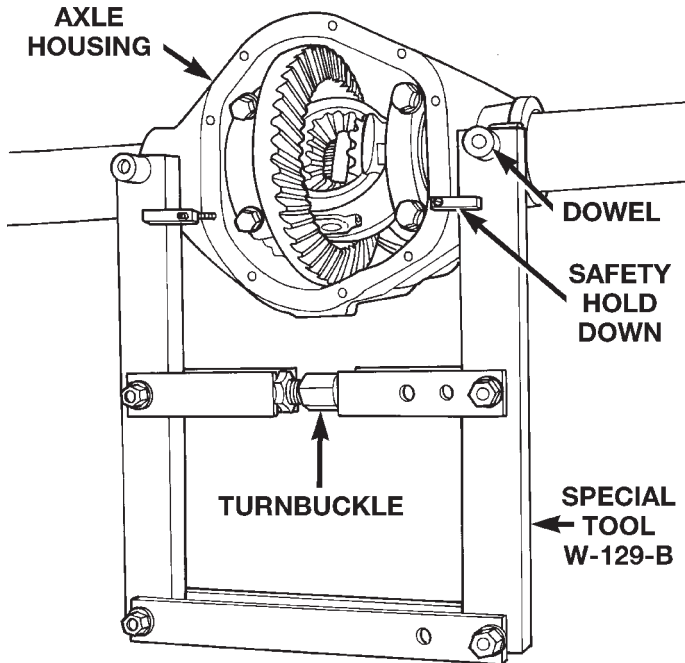
(14) Remove spreader from housing.

INSTALLATION

If replacement differential bearings or differential case are being installed, differential side bearing shim requirements may change. Refer to the Differential Bearing Preload and Gear Backlash procedures in this section to determine the proper shim selection.

REMOVAL AND INSTALLATION (Continued)

(1) Position Spreader W-129-B, utilizing some items from Adapter Kit 6987, with the tool dowel pins seated in the locating holes (Fig. 35). Install the holddown clamps and tighten the tool turnbuckle finger-tight.



80a534c5

Fig. 35 Install Axle Housing Spreader

(2) Install a Guide Pin C-3288-B at the left side of the differential housing. Attach Dial Indicator C-3339 to guide pin. Load the lever adapter against the opposite side of the housing (Fig. 32) and zero the indicator.

CAUTION: Do not spread over 0.50 mm (0.020 in). If the housing is over-spread, it could be distorted or damaged.

(3) Spread the housing enough to install the case in the housing. Measure the distance with the dial indicator (Fig. 33).

(4) Remove the dial indicator.

(5) Install differential case in the housing. Ensure that the differential bearing cups remain in position on the differential bearings. Tap the differential case to ensure the bearings cups are fully seated in the housing.

(6) Install the bearing caps at their original locations (Fig. 36).

(7) Loosely install differential bearing cap bolts.

(8) Remove axle housing spreader.

(9) Tighten the bearing cap bolts to 61 N·m (45 ft. lbs.) torque.

(10) Install the hub bearings and axle shafts.

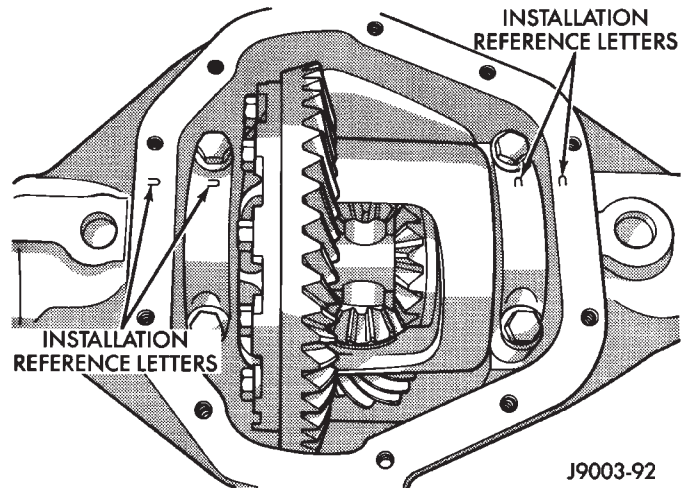


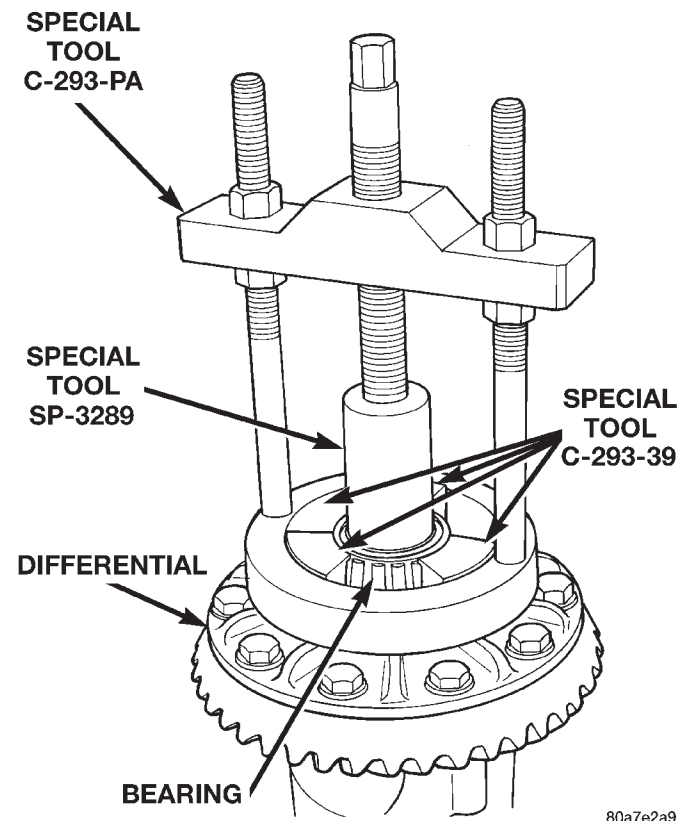
Fig. 36 Differential Bearing Cap Reference Letters

DIFFERENTIAL SIDE BEARINGS

REMOVAL

(1) Remove differential case from axle housing.

(2) Remove the bearings from the differential case with Puller/Press C-293-PA, C-293-39 Adapter Blocks, and Plug SP-3289 (Fig. 37).



80a7e2a9

Fig. 37 Differential Bearing Removal

REMOVAL AND INSTALLATION (Continued)**INSTALLATION**

If replacement differential side bearings or differential case are being installed, differential side bearing shim requirements may change. Refer to the Differential Bearing Preload and Gear Backlash procedures in this section to determine the proper shim selection.

- (1) Install differential side bearing shims onto differential case hubs.
- (2) Using Installer C-3716-A and Handle C-4171, install differential side bearings (Fig. 38).

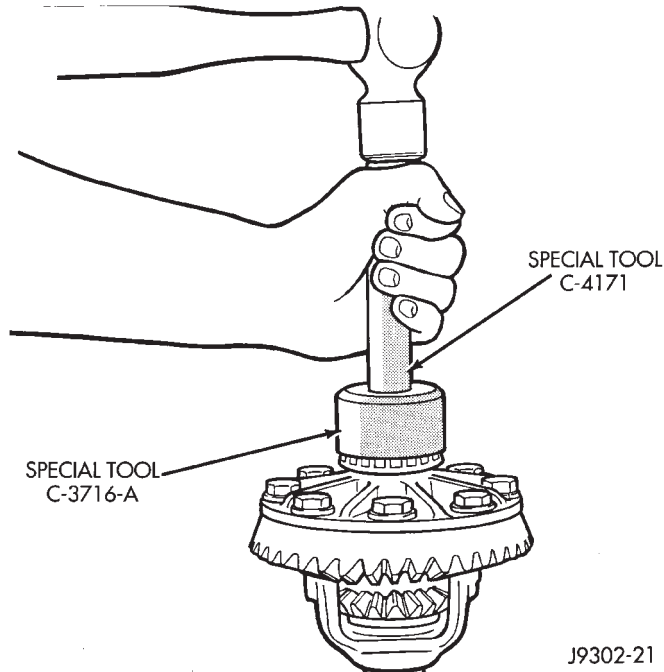


Fig. 38 Differential Side Bearing Installation

- (3) Install differential in axle housing.

AXLE SHAFT OIL SEAL**REMOVAL**

- (1) Raise and support vehicle.
- (2) Remove differential assembly.
- (3) Remove the inner axle shaft seals with a pry bar.

INSTALLATION

- (1) Remove any sealer remaining from original seals.
- (2) Remove sealer from axle tube to housing junction, if necessary.
- (3) Install oil seals with Discs 8110 and Turnbuckle 6797 (Fig. 39). Tighten tool until disc bottoms in housing.
- (4) Install differential assembly.

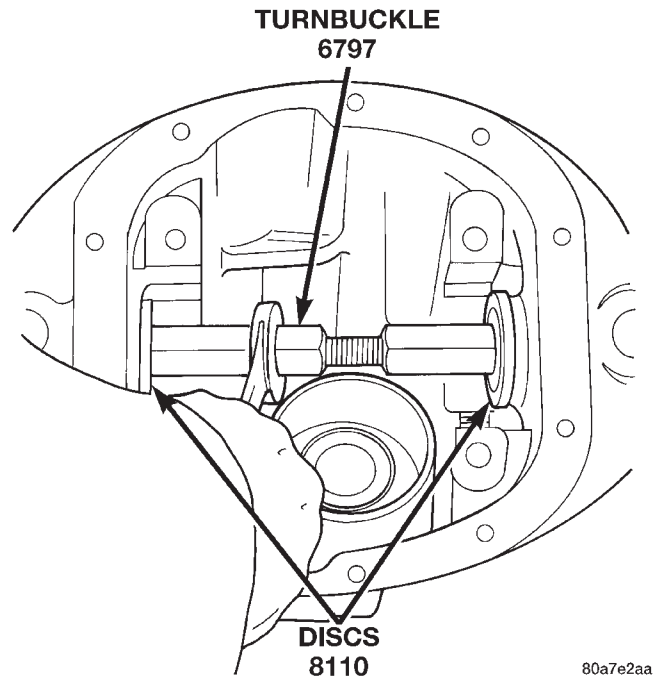


Fig. 39 Axle Seal Installation

PINION GEAR

NOTE: The ring and pinion gears are serviced as a matched set. Do not replace the pinion gear without replacing the ring gear.

REMOVAL

- (1) Remove differential assembly from axle housing.
- (2) Mark pinion yoke, or flange, and propeller shaft for installation alignment.
- (3) Disconnect propeller shaft from pinion yoke, or flange. Using suitable wire, tie propeller shaft to underbody.
- (4) Using Holder 6958 to hold yoke, or flange, and a short length of 1 in. pipe, remove the pinion nut and washer (Fig. 40).
- (5) Using Remover C-452 and Holder C-3281, remove the pinion yoke, or flange, from pinion shaft (Fig. 41).

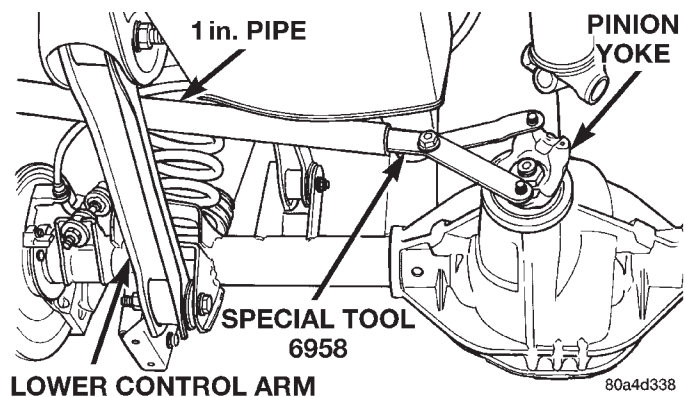


Fig. 40 Pinion Yoke Holder—Typical

REMOVAL AND INSTALLATION (Continued)

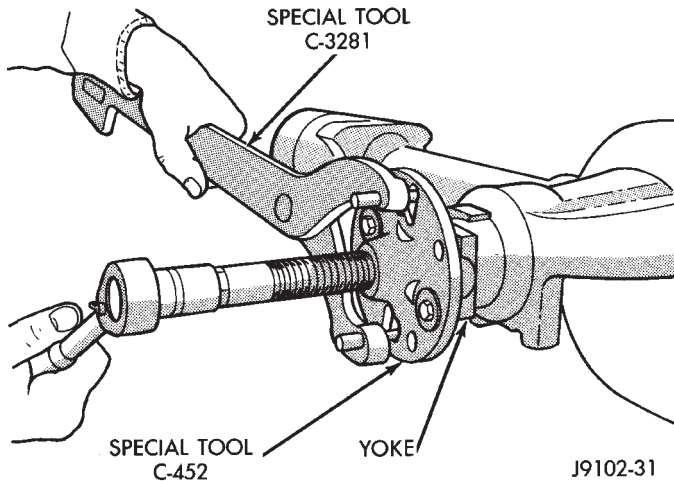


Fig. 41 Pinion Yoke Removal

(6) Remove the pinion gear and collapsible spacer from housing (Fig. 42). Catch the pinion with your hand to prevent it from falling and being damaged.

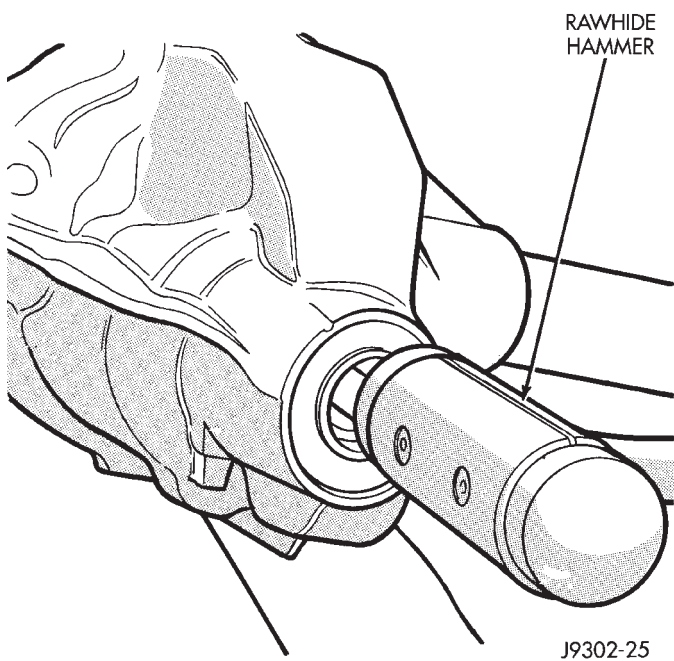


Fig. 42 Remove Pinion Gear

(7) Remove the front pinion bearing cup, bearing, oil slinger, if equipped, and pinion seal with Remover C-4345 and Handle C-4171 (Fig. 43).

(8) Remove the rear pinion bearing cup from axle housing (Fig. 44). Use Remover D-149 and Handle C-4171.

(9) Remove the depth shims from rear pinion bearing cup bore in axle housing. Record the thickness of the depth shims.

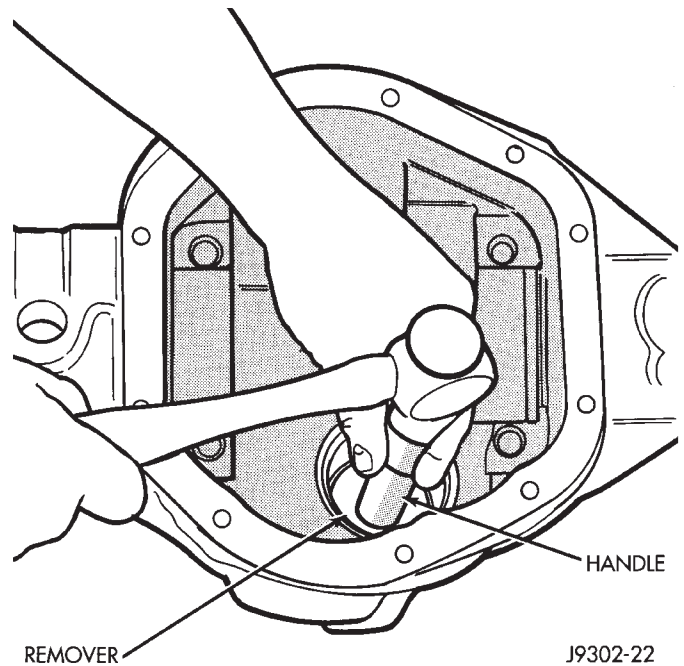


Fig. 43 Front Bearing Cup Removal

NOTE: The pinion depth shims can be very thin. Verify that all shims have been removed before proceeding.

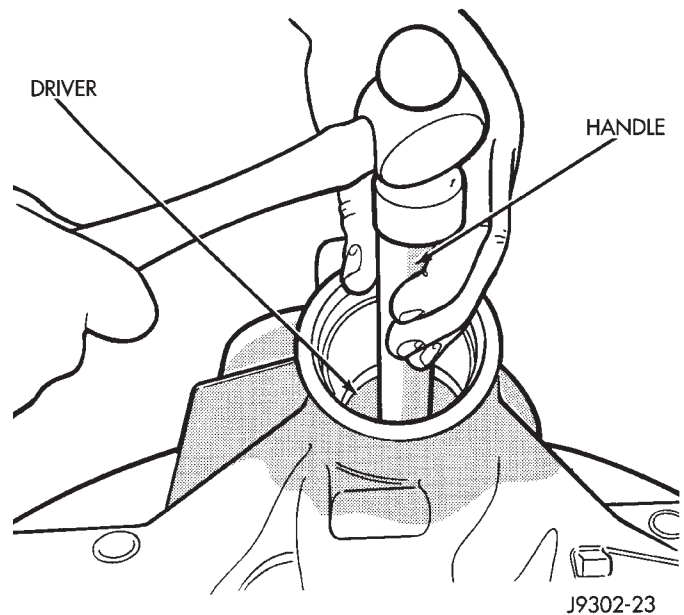


Fig. 44 Rear Bearing Cup Removal

(10) Remove the collapsible preload spacer from pinion gear (Fig. 45).

(11) Remove the rear pinion bearing from the pinion with Puller/Press C-293-PA and Adapters C-293-39 (Fig. 46).

Place 4 adapter blocks so they do not damage the bearing cage.

REMOVAL AND INSTALLATION (Continued)

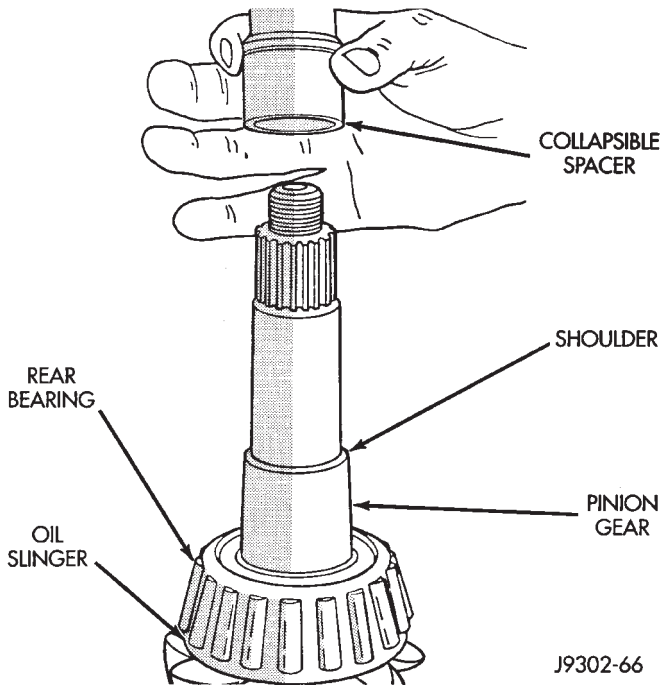


Fig. 45 Collapsible Spacer

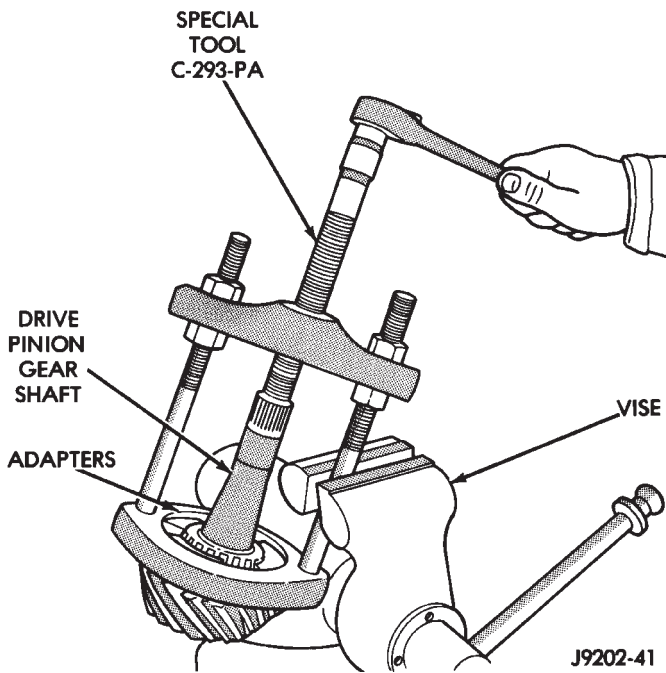


Fig. 46 Inner Bearing Removal

INSTALLATION

NOTE: Pinion depth shims are placed between the rear pinion bearing cup and axle housing to achieve proper ring and pinion gear mesh. If the factory installed ring and pinion gears are reused, the pinion depth shim should not require replacement. Refer to Pinion Gear Depth to select the proper thickness shim before installing pinion gear.

- (1) Place proper thickness depth shim in rear pinion bearing cup bore in the axle housing.
- (2) Apply Mopar® Door Ease, or equivalent, stick lubricant to outside surface of rear pinion bearing cup. Install the bearing cup with Installer D-146 and Driver Handle C-4171 (Fig. 47). Verify cup is correctly seated.

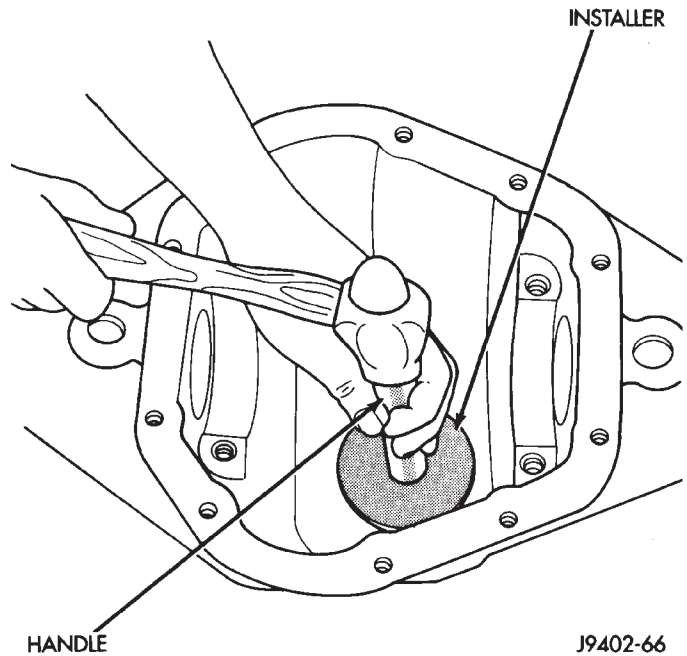


Fig. 47 Rear Pinion Bearing Cup Installation

- (3) Apply Mopar® Door Ease, or equivalent, stick lubricant to outside surface of front pinion bearing cup. Install the bearing cup with Installer D-130 and Handle C-4171 (Fig. 48).

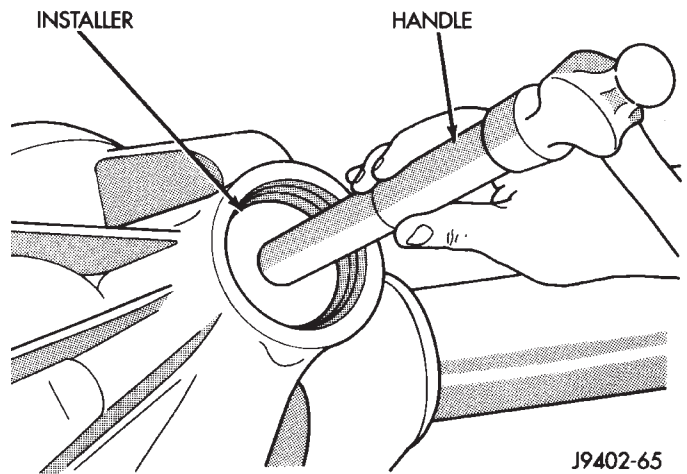


Fig. 48 Pinion Outer Bearing Cup Installation

- (4) Install front pinion bearing, and oil slinger, if equipped.

REMOVAL AND INSTALLATION (Continued)

(5) Apply a light coating of gear lubricant on the lip of pinion seal. Install seal with Installer C-3972-A and Handle C-4171 (Fig. 49).

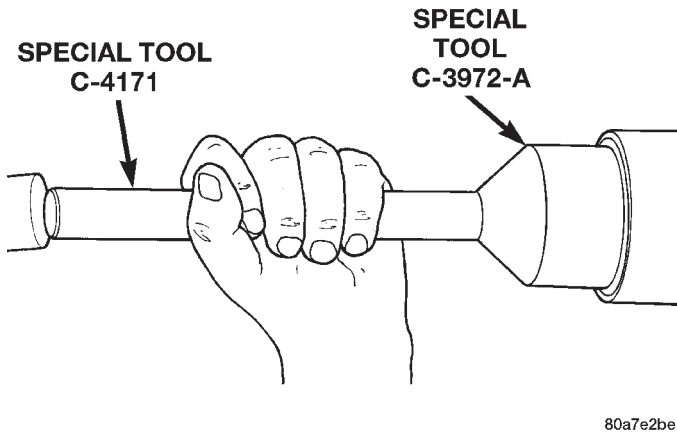


Fig. 49 Pinion Seal Installation

(6) Install the rear pinion bearing and oil slinger, if equipped, on the pinion gear with Installer W-262 and a shop press (Fig. 50).

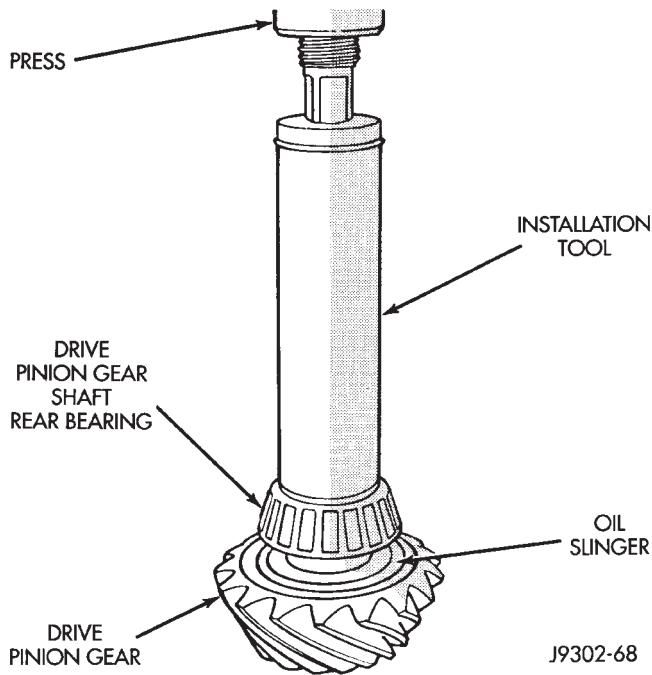


Fig. 50 Rear Pinion Bearing Installation

(7) Install a new collapsible preload spacer on pinion shaft and install pinion gear in housing (Fig. 51).

(8) Install yoke, or flange, with Installer W-162-B, Cup 8109, and Holder 6958 (Fig. 52).

(9) Install the pinion washer and a new nut on the pinion gear. Tighten the nut to 216 N·m (160 ft. lbs.) minimum. **Do not over-tighten.** Maximum torque is 352 N·m (260 ft. lbs.).

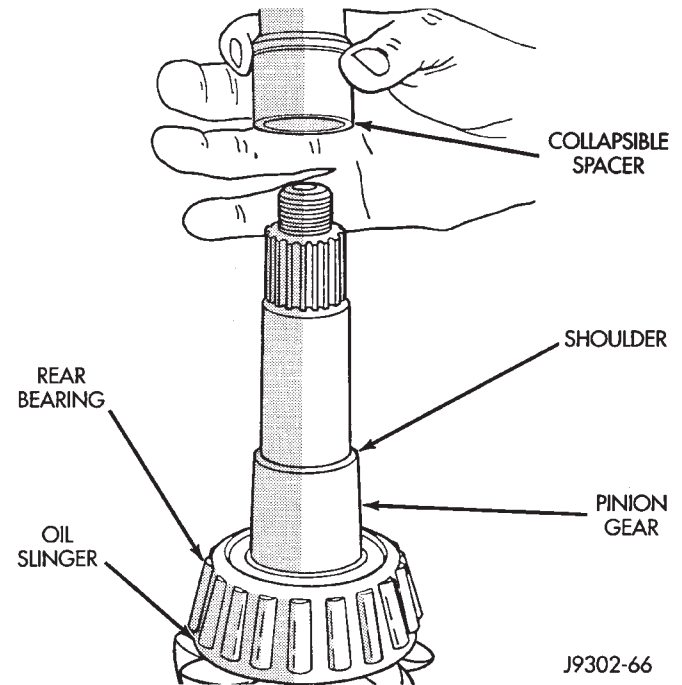


Fig. 51 Collapsible Preload Spacer

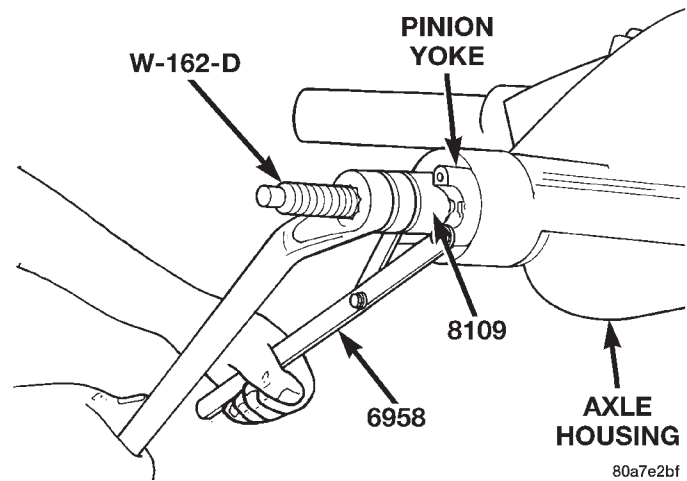


Fig. 52 Pinion Yoke Installation

CAUTION: Never loosen pinion gear nut to decrease pinion gear bearing rotating torque and never exceed specified preload torque. If preload torque is exceeded a new collapsible spacer must be installed. The torque sequence will then have to be repeated.

NOTE: If the spacer requires more than 352 N·m (260 ft. lbs.) of torque to crush, the collapsible spacer is defective.

(10) Using Holder 6958, a short length of 1 in. pipe, and torque wrench (set at 352 N·m (260 ft. lbs.)), crush collapsible spacer until bearing end play is taken up (Fig. 53).

REMOVAL AND INSTALLATION (Continued)

(11) Slowly tighten the nut in 6.8 N·m (5 ft. lb.) increments until the rotating torque is achieved. Measure the rotating torque frequently to avoid over crushing the collapsible spacer (Fig. 54).

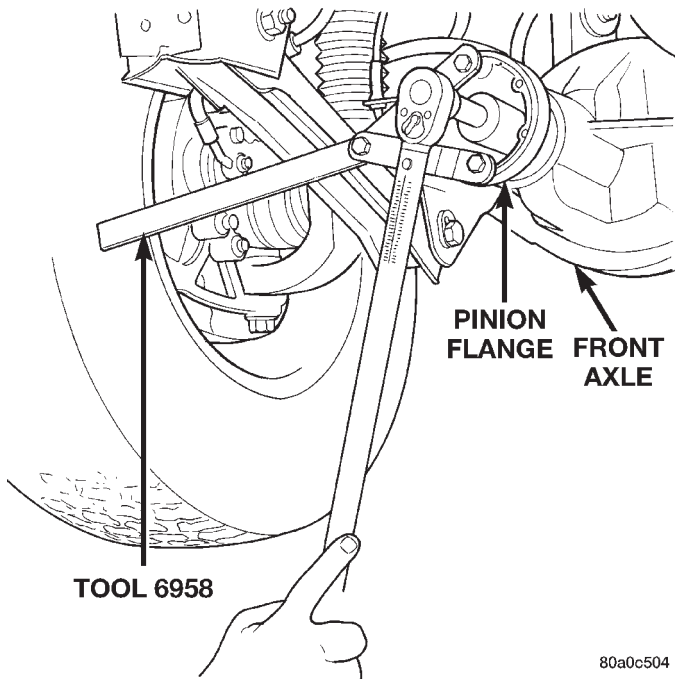


Fig. 53 Tightening Pinion Nut

(12) Check bearing rotating torque with an inch pound torque wrench (Fig. 54). The torque necessary to rotate the pinion gear should be:

- Original Bearings — 1 to 3 N·m (10 to 20 in. lbs.).
- New Bearings — 2 to 5 N·m (15 to 35 in. lbs.).

(13) Install differential assembly.

RING GEAR

The ring and pinion gears are service in a matched set. Do not replace the ring gear without replacing the pinion gear.

REMOVAL

- (1) Remove differential from axle housing.
- (2) Place differential case in a suitable vise with soft metal jaw protectors. (Fig. 55)
- (3) Remove bolts holding ring gear to differential case.
- (4) Using a soft hammer, drive ring gear from differential case (Fig. 55).

INSTALLATION

CAUTION: Do not reuse the bolts that held the ring gear to the differential case. The bolts can fracture causing extensive damage.

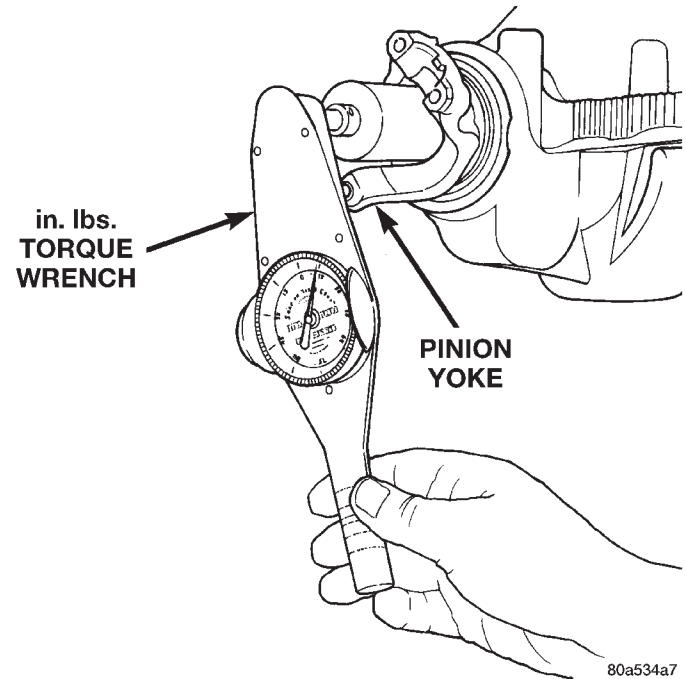


Fig. 54 Check Pinion Gear Rotation Torque

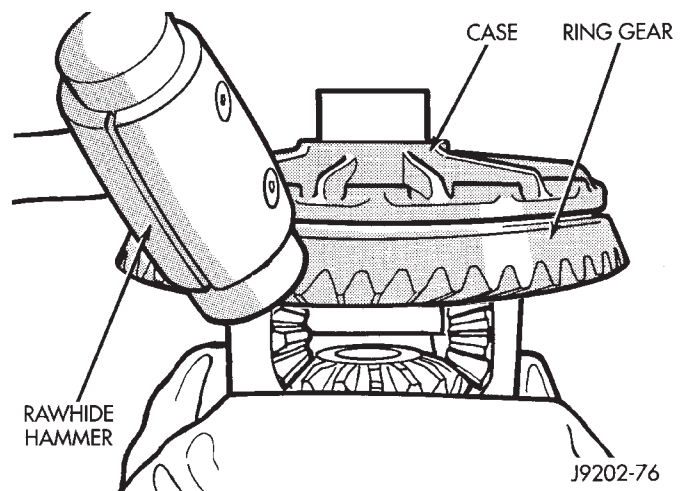


Fig. 55 Ring Gear Removal

- (1) Invert the differential case and start two ring gear bolts. This will provide case-to-ring gear bolt hole alignment.
- (2) Invert the differential case in the vise.
- (3) Install new ring gear bolts and alternately tighten to 95–122 N·m (70–90 ft. lbs.) torque (Fig. 56).
- (4) Install differential in axle housing and verify gear mesh and contact pattern.

REMOVAL AND INSTALLATION (Continued)

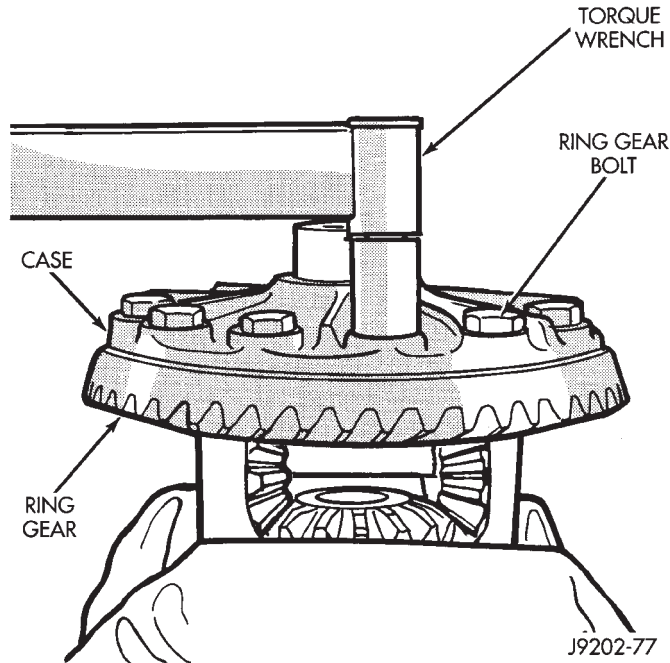


Fig. 56 Ring Gear Bolt Installation

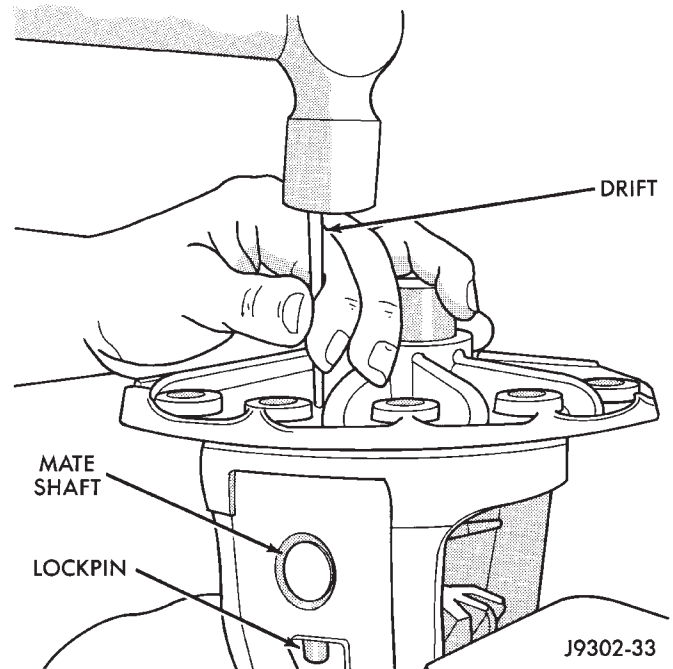


Fig. 57 Mate Shaft Roll Pin Removal

DISASSEMBLY AND ASSEMBLY

STANDARD DIFFERENTIAL

DISASSEMBLY

- (1) Remove the ring gear.
- (2) Using a suitable roll pin punch, drive out the roll pin holding pinion gear mate shaft in the differential case (Fig. 57).
- (3) Remove the pinion gear mate shaft from the differential case and the pinion mate gears.
- (4) Rotate differential side gears and remove the pinion mate gears and thrust washers (Fig. 58).
- (5) Remove the differential side gears and thrust washers.

ASSEMBLY

- (1) Install the differential side gears and thrust washers.
- (2) Install the pinion mate gears and thrust washers.
- (3) Install the pinion gear mate shaft. Align the roll pin holes in shaft and the differential case.
- (4) Install the roll pin to hold the pinion mate shaft in the differential case (Fig. 59).
- (5) Install the ring gear.
- (6) Lubricate all differential components with hypoid gear lubricant.

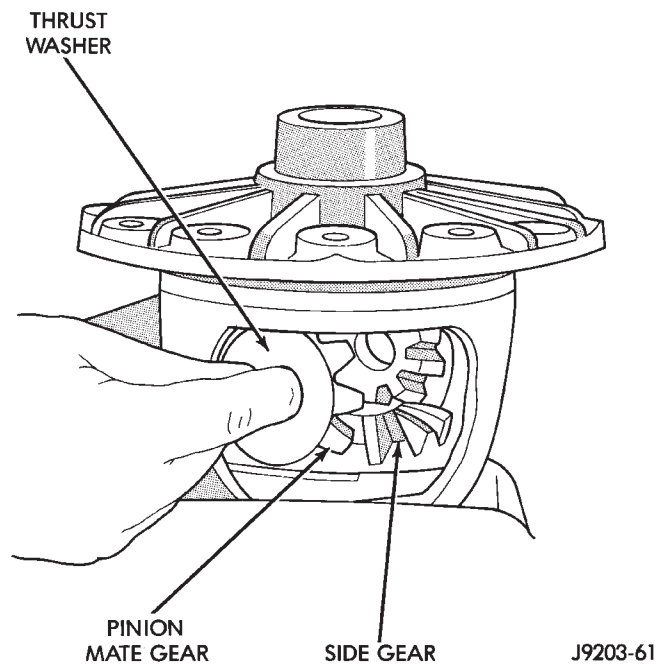


Fig. 58 Pinion Mate Gear Removal

FINAL ASSEMBLY

(1) Scrape the residual sealant from the housing and cover mating surfaces. Clean the mating surfaces with mineral spirits. Apply a bead of Mopar® Silicone Rubber Sealant, or equivalent, on the housing cover (Fig. 60).

Install the housing cover within 5 minutes after applying the sealant.

DISASSEMBLY AND ASSEMBLY (Continued)

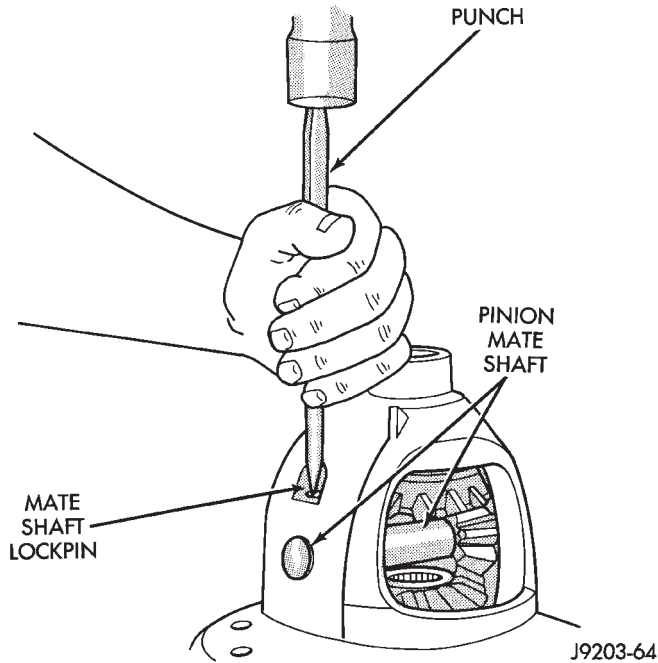


Fig. 59 Mate Shaft Roll Pin Installation

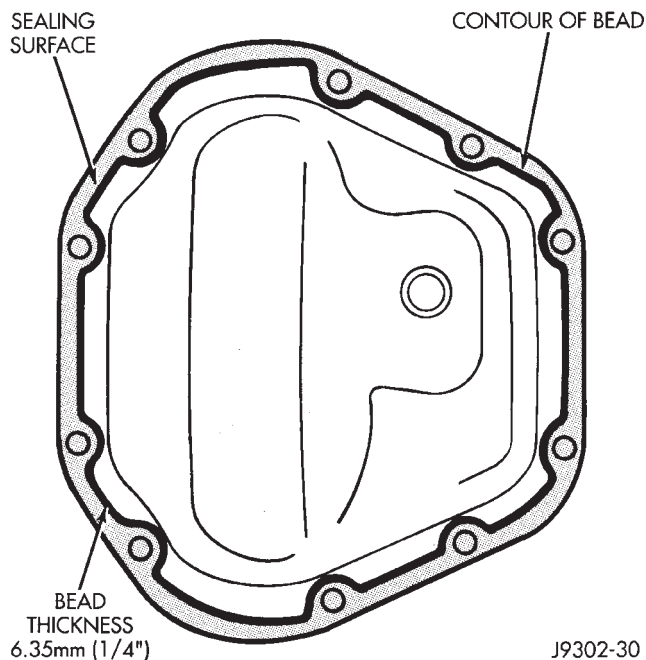


Fig. 60 Typical Housing Cover With Sealant

(2) Install the cover on the differential with the attaching bolts. Install the identification tag. Tighten the cover bolts to 41 N·m (30 ft. lbs.) torque.

CAUTION: Overfilling the differential can result in lubricant foaming and overheating.

(3) Refill the differential housing with gear lubricant. Refer to the Lubricant Specifications section of this group for the gear lubricant requirements.

(4) Install the fill hole plug.

CLEANING AND INSPECTION

CARDAN U-JOINT

Clean all the U-joint yoke bores with cleaning solvent and a wire brush. Ensure that all the rust and foreign matter are removed from the bores.

Inspect the yokes for distortion, cracks and worn bearing cap bores.

Replace the complete U-joint if any of the components are defective.

AXLE COMPONENTS

Wash differential components with cleaning solvent and dry with compressed air. **Do not steam clean the differential components.**

Wash bearings with solvent and towel dry, or dry with compressed air. **DO NOT** spin bearings with compressed air. **Cup and bearing must be replaced as matched sets only.**

Clean axle shaft tubes and oil channels in housing. Inspect for;

- Smooth appearance with no broken/dented surfaces on the bearing rollers or the roller contact surfaces.
- Bearing cups must not be distorted or cracked.
- Machined surfaces should be smooth and without any raised edges.
- Raised metal on shoulders of cup bores should be removed with a hand stone.
- Wear and damage to pinion gear mate shaft, pinion gears, side gears and thrust washers. Replace as a matched set only.
- Ring and pinion gear for worn and chipped teeth.
- Ring gear for damaged bolt threads. Replaced as a matched set only.
- Pinion yoke for cracks, worn splines, pitted areas, and a rough/corroded seal contact surface. Repair or replace as necessary.
- Preload shims for damage and distortion. Install new shims, if necessary.

ADJUSTMENTS

PINION GEAR DEPTH

GENERAL INFORMATION

Ring and pinion gears are supplied as matched sets only. The identifying numbers for the ring and pinion gear are etched into the face of each gear (Fig. 61). A plus (+) number, minus (−) number or zero (0) is etched into the face of the pinion gear. This number is the amount (in thousandths of an inch) the

ADJUSTMENTS (Continued)

depth varies from the standard depth setting of a pinion etched with a (0). The standard setting from the center line of the ring gear to the back face of the pinion is 92.08 mm (3.625 in.). The standard depth provides the best gear tooth contact pattern. Refer to Backlash and Contact Pattern Analysis paragraph in this section for additional information.

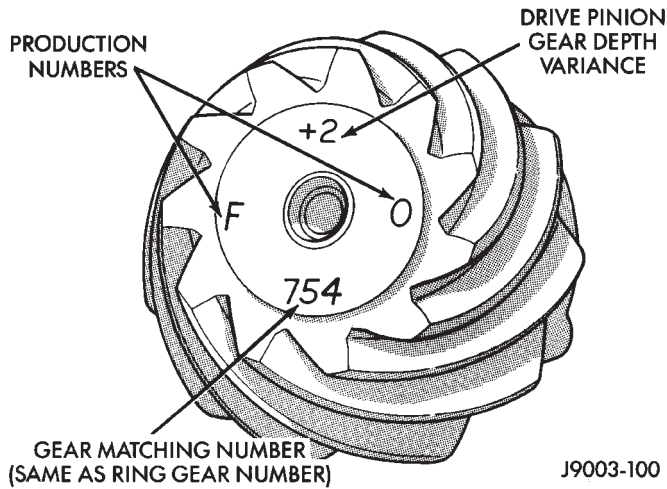


Fig. 61 Pinion Gear ID Numbers

Compensation for pinion depth variance is achieved with select shims. The shims are placed behind the rear pinion bearing cup (Fig. 62).

If a new gear set is being installed, note the depth variance etched into both the original and replacement pinion gear. Add or subtract the thickness of the original depth shims to compensate for the difference in the depth variances. Refer to the Depth Variance chart.

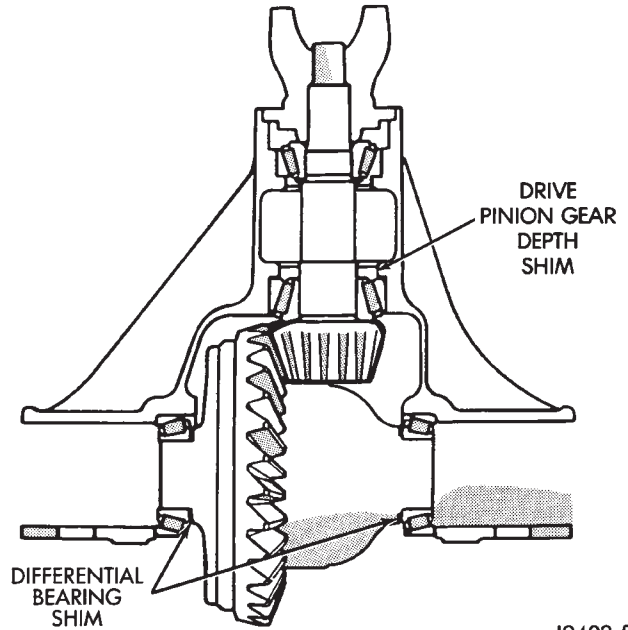


Fig. 62 Shim Locations

J9402-5

Note where Old and New Pinion Marking columns intersect. Intersecting figure represents plus or minus the amount needed.

Note the etched number on the face of the drive pinion gear (-1, -2, 0, +1, +2, etc.). The numbers represent thousands of an inch deviation from the standard. If the number is negative, add that value to the required thickness of the depth shims. If the number is positive, subtract that value from the thickness of the depth shim. If the number is 0 no change is necessary.

PINION GEAR DEPTH VARIANCE

Original Pinion Gear Depth Variance	Replacement Pinion Gear Depth Variance								
	-4	-3	-2	-1	0	+1	+2	+3	+4
+4	+0.008	+0.007	+0.006	+0.005	+0.004	+0.003	+0.002	+0.001	0
+3	+0.007	+0.006	+0.005	+0.004	+0.003	+0.002	+0.001	0	-0.001
+2	+0.006	+0.005	+0.004	+0.003	+0.002	+0.001	0	-0.001	-0.002
+1	+0.005	+0.004	+0.003	+0.002	+0.001	0	-0.001	-0.002	-0.003
0	+0.004	+0.003	+0.002	+0.001	0	-0.001	-0.002	-0.003	-0.004
-1	+0.003	+0.002	+0.001	0	-0.001	-0.002	-0.003	-0.004	-0.005
-2	+0.002	+0.001	0	-0.001	-0.002	-0.003	-0.004	-0.005	-0.006
-3	+0.001	0	-0.001	-0.002	-0.003	-0.004	-0.005	-0.006	-0.007
-4	0	-0.001	-0.002	-0.003	-0.004	-0.005	-0.006	-0.007	-0.008

J8902-46

ADJUSTMENTS (Continued)**PINION DEPTH MEASUREMENT AND ADJUSTMENT**

Measurements are taken with pinion bearing cups and pinion bearings installed in the axle housing without any shims placed behind the rear pinion bearing cup. Take measurements with Pinion Gauge Set 6774 and Dial Indicator C-3339 (Fig. 63).

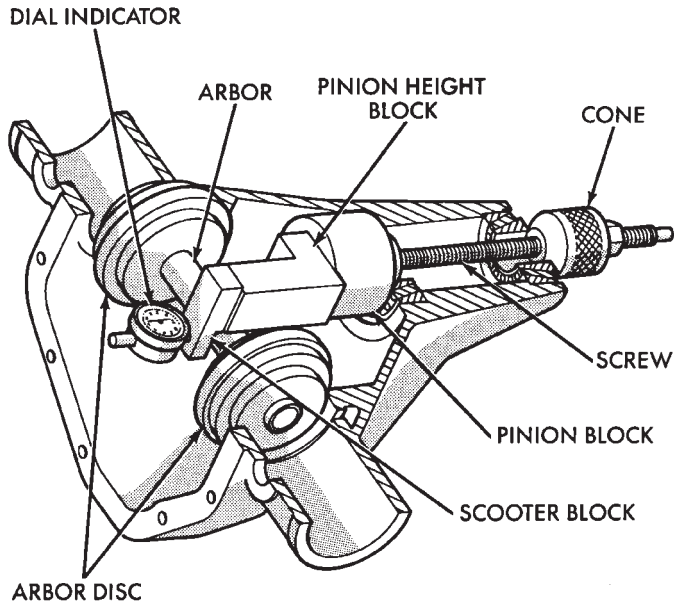


Fig. 63 Pinion Gear Depth Gauge Tools—Typical

(1) Assemble Pinion Height Block 6739, Pinion Block 6733, and rear pinion bearing onto Screw 6741 (Fig. 63).

(2) Insert assembled height gauge components, rear bearing and screw into axle housing through pinion bearing cups (Fig. 64).

(3) Install front pinion bearing cone and Cone-nut 6740 hand tight (Fig. 63).

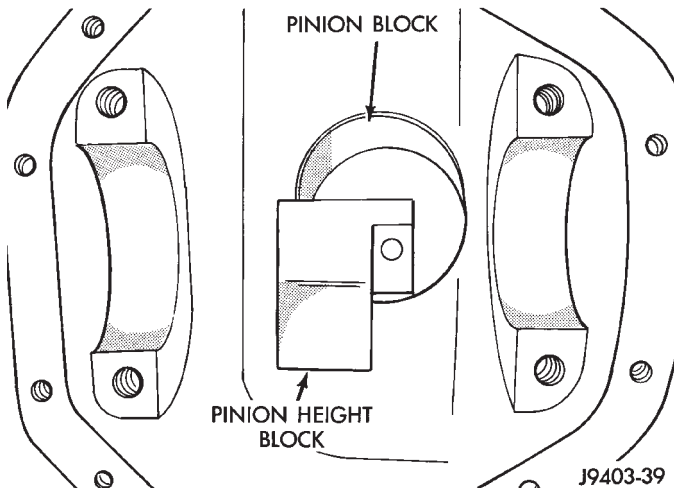


Fig. 64 Pinion Height Block—Typical

(4) Place Arbor Disc 6732 on Arbor D-115-3 in position in axle housing side bearing cradles (Fig. 65). Install differential bearing caps on Arbor Discs and tighten cap bolts to 41 N·m (30 ft. lbs.).

NOTE: Arbor Discs 6732 has different step diameters to fit other axles. Choose proper step for axle being serviced.

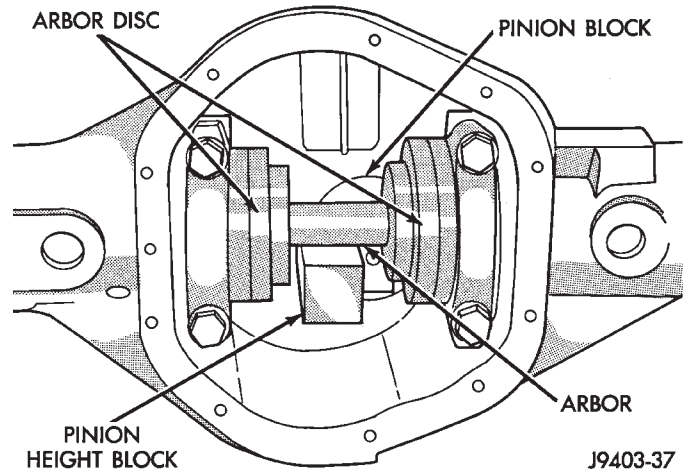


Fig. 65 Gauge Tools In Housing—Typical

(5) Assemble Dial Indicator C-3339 into Scooter Block D-115-2 and secure set screw.

(6) Place Scooter Block/Dial Indicator in position in axle housing so dial probe and scooter block are flush against the rearward surface of the pinion height block (Fig. 63). Hold scooter block in place and zero the dial indicator face to the pointer. Tighten dial indicator face lock screw.

(7) With scooter block still in position against the pinion height block, slowly slide the dial indicator probe over the edge of the pinion height block.

(8) Slide the dial indicator probe across the gap between the pinion height block and the arbor bar with the scooter block against the pinion height block (Fig. 66). When the dial probe contacts the arbor bar, the dial pointer will turn clockwise. Bring dial pointer back to zero against the arbor bar, do not turn dial face. Continue moving the dial probe to the crest of the arbor bar and record the highest reading. If the dial indicator can not achieve the zero reading, the rear bearing cup or the pinion depth gauge set is not installed correctly.

(9) Select a shim equal to the dial indicator reading plus the drive pinion gear depth variance number etched in the face of the pinion gear (Fig. 61). For example, if the depth variance is -2 , add $+0.002$ in. to the dial indicator reading.

ADJUSTMENTS (Continued)

NOTE: If an oil slinger is used behind the inner pinion bearing cone, deduct the thickness of the slinger from the dial indicator reading and use that total for shim selection.

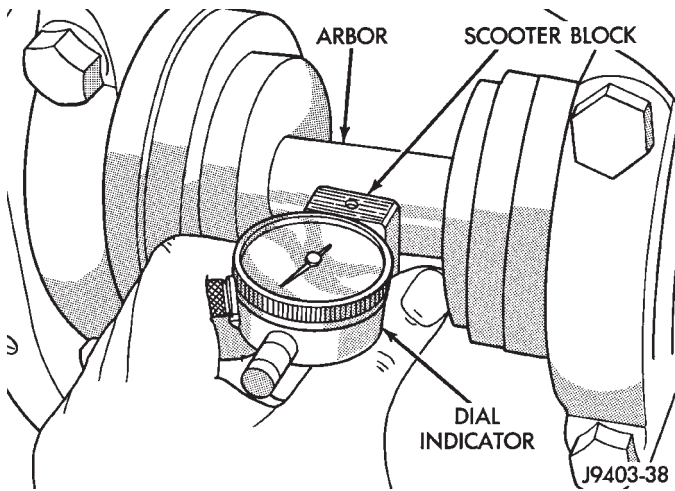


Fig. 66 Pinion Gear Depth Measurement—Typical

DIFFERENTIAL BEARING PRELOAD AND GEAR BACKLASH

INTRODUCTION

Differential side bearing preload and gear backlash is achieved by selective shims positioned behind the differential side bearing cones. The proper shim thickness can be determined using slip-fit dummy bearings D-348 in place of the differential side bearings and a dial indicator C-3339. Before proceeding with the differential bearing preload and gear backlash measurements, measure the pinion gear depth and prepare the pinion gear for installation. Establishing proper pinion gear depth is essential to establishing gear backlash and tooth contact patterns. After the overall shim thickness to take up differential side play is measured, the pinion gear is installed, and the gear backlash shim thickness is measured. The overall shim thickness is the total of the dial indicator reading and the preload specification added together. The gear backlash measurement determines the thickness of the shim used on the ring gear side of the differential case. Subtract the gear backlash shim thickness from the total overall shim thickness and select that amount for the pinion gear side of the differential (Fig. 67). Differential shim measurements are performed with axle spreader W-129-B removed.

SHIM SELECTION

NOTE: It is difficult to salvage the differential side bearings during the removal procedure. Install replacement bearings if necessary.

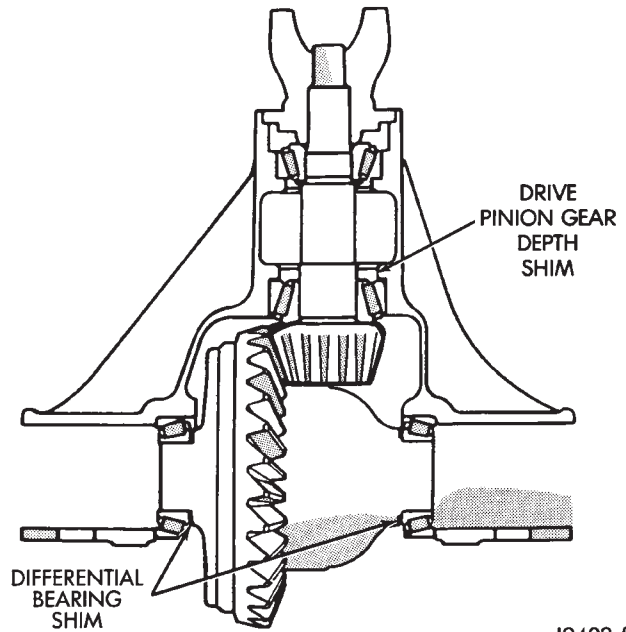


Fig. 67 Axle Adjustment Shim Locations

- (1) Remove differential side bearings from differential case.
- (2) Remove factory installed shims from differential case.
- (3) Install ring gear on differential case and tighten bolts to specification.
- (4) Install dummy side bearings D-348 on differential case.
- (5) Install differential case in axle housing.
- (6) Install the marked bearing caps in their correct positions. Install and snug the bolts (Fig. 68).

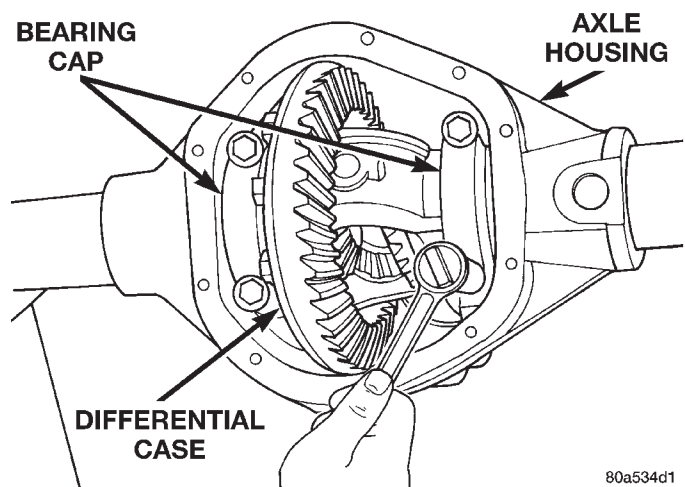


Fig. 68 Tighten Bolts Holding Bearing Caps

- (7) Using a dead-blow type mallet, seat the differential dummy bearings to each side of the axle housing (Fig. 69) and (Fig. 70).

ADJUSTMENTS (Continued)

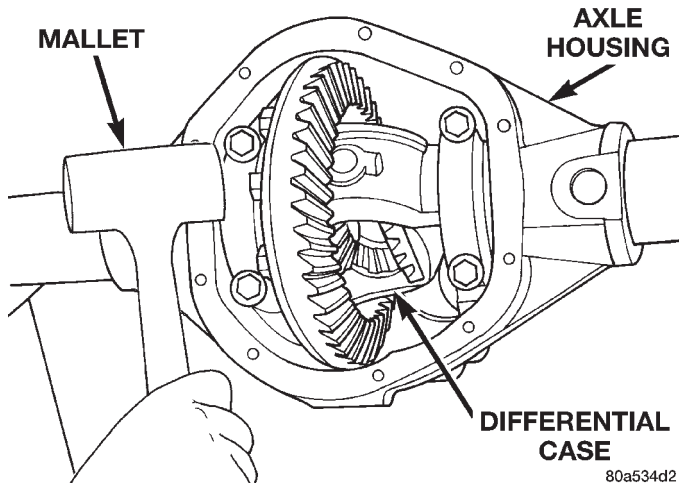


Fig. 69 Seat Pinion Gear Side Differential Dummy Side Bearing

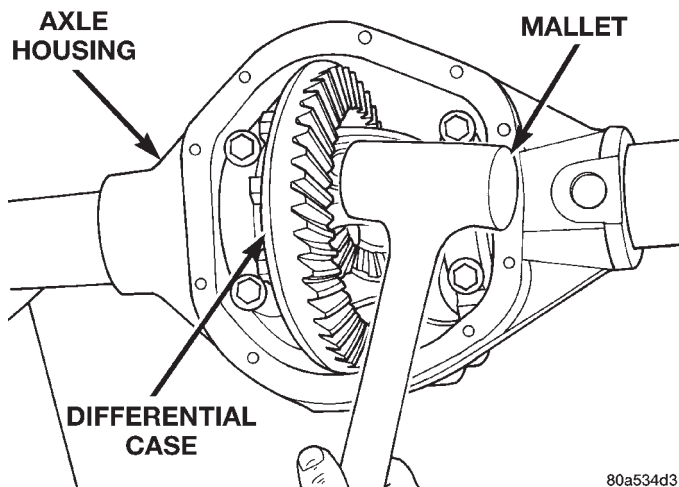


Fig. 70 Seat Ring Gear Side Differential Dummy Side Bearing

(8) Thread guide stud C-3288-B into rear cover bolt hole below ring gear (Fig. 71).

(9) Attach a dial indicator C-3339 to guide stud. Position the dial indicator plunger on a flat surface between the ring gear bolt heads (Fig. 71).

(10) Push and hold differential case to pinion gear side of axle housing (Fig. 72).

(11) Zero dial indicator face to pointer (Fig. 72).

(12) Push and hold differential case to ring gear side of the axle housing (Fig. 73).

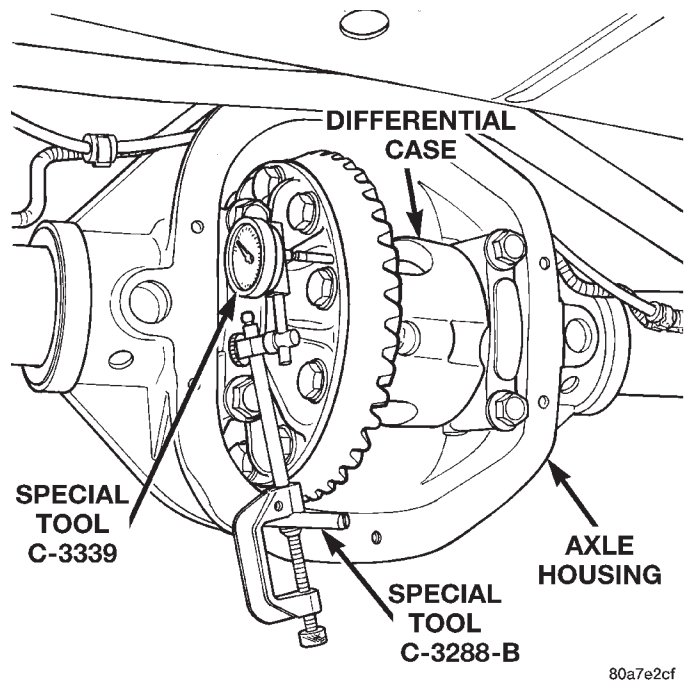


Fig. 71 Differential Side play Measurement

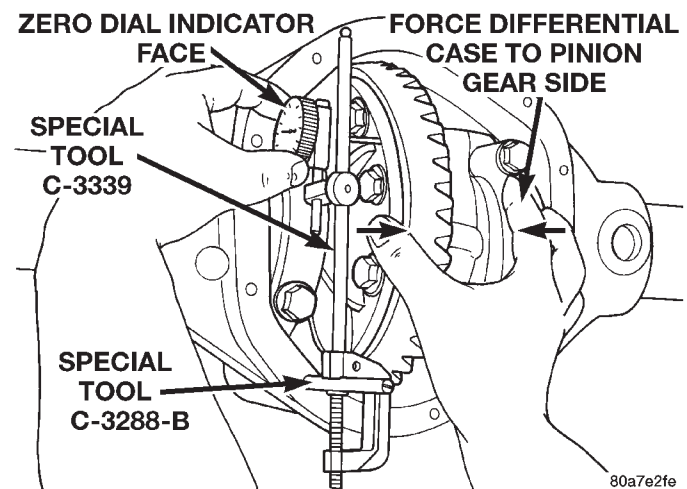


Fig. 72 Hold Differential Case and Zero Dial Indicator

ADJUSTMENTS (Continued)

(13) Record dial indicator reading (Fig. 73).

(14) Add 0.008 in. (0.2 mm) to the zero end play total. This new total represents the thickness of shims to compress, or preload the new bearings when the differential is installed.

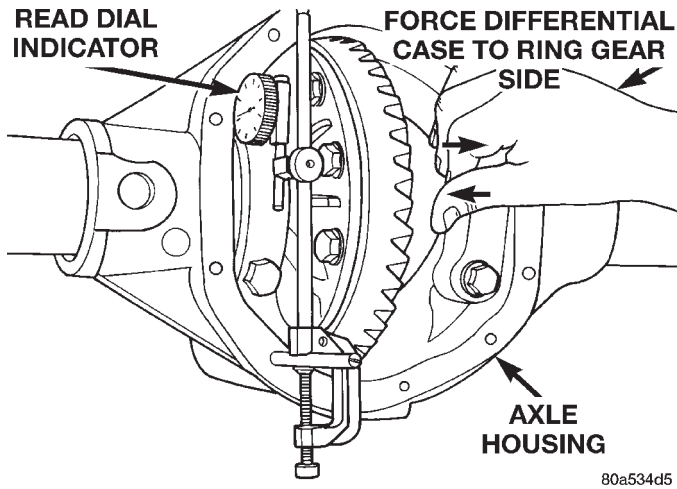


Fig. 73 Hold Differential Case and Read Dial Indicator

(15) Rotate dial indicator out of the way on the guide stud.

(16) Remove differential case and dummy bearings from axle housing.

(17) Install the pinion gear in axle housing. Install the pinion yoke, or flange, and establish the correct pinion rotating torque.

(18) Install differential case and dummy bearings D-348 in axle housing (without shims), install bearing caps and tighten bolts snug.

(19) Seat ring gear side dummy bearing (Fig. 70).

(20) Position the dial indicator plunger on a flat surface between the ring gear bolt heads. (Fig. 71).

(21) Push and hold differential case toward pinion gear (Fig. 74).

(22) Zero dial indicator face to pointer (Fig. 74).

(23) Push and hold differential case to ring gear side of the axle housing (Fig. 75).

(24) Record dial indicator reading (Fig. 75).

(25) Subtract 0.002 in. (0.05 mm) from the dial indicator reading to compensate for backlash between ring and pinion gears. This total is the thickness shim required to achieve proper backlash.

(26) Subtract the backlash shim thickness from the total preload shim thickness. The remainder is the shim thickness required on the pinion side of the axle housing.

(27) Rotate dial indicator out of the way on guide stud.

(28) Remove differential case and dummy bearings from axle housing.

(29) Install side bearing shims on differential case hubs.

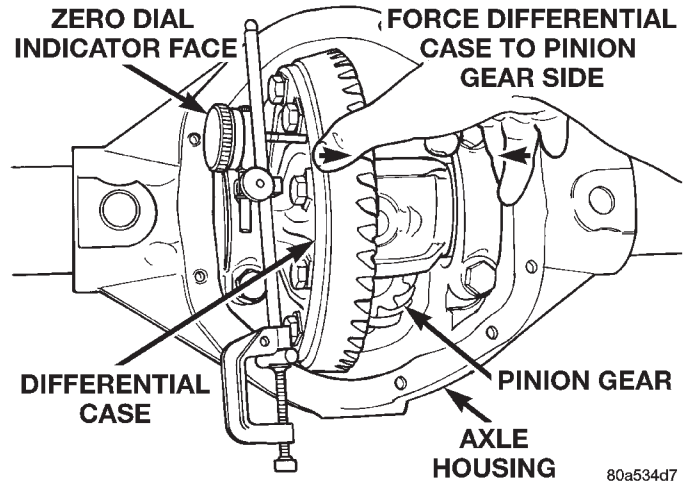


Fig. 74 Hold Differential Case and Zero Dial Indicator

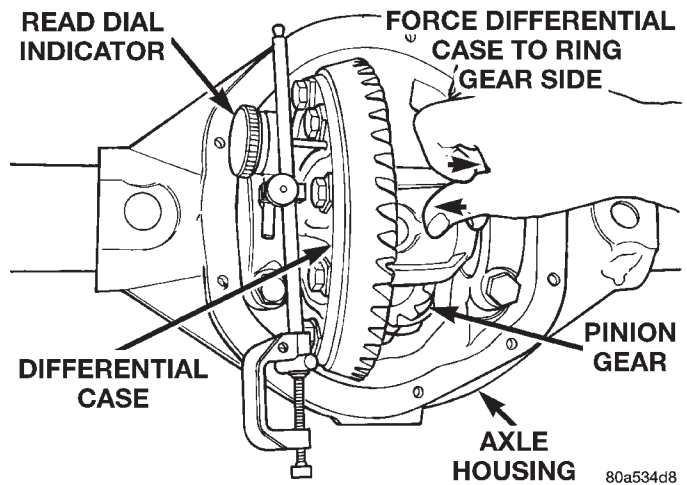


Fig. 75 Hold Differential Case and Read Dial Indicator

(30) Install side bearings and cups on differential case.

(31) Install spreader W-129-B, utilizing some items from Adapter Set 6987, on axle housing and spread axle opening enough to receive differential case.

(32) Install differential case in axle housing.

(33) Remove spreader from axle housing.

(34) Rotate the differential case several times to seat the side bearings.

(35) Position the indicator plunger against a ring gear tooth (Fig. 76).

(36) Push and hold ring gear upward while not allowing the pinion gear to rotate.

(37) Zero dial indicator face to pointer.

(38) Push and hold ring gear downward while not allowing the pinion gear to rotate. Dial indicator reading should be between 0.12 mm (0.005 in.) and 0.20 mm (0.008 in.). If backlash is not within specifications transfer the necessary amount of shim thick-

ADJUSTMENTS (Continued)

ness from one side of the axle housing to the other (Fig. 77).

(39) Verify differential case and ring gear runout by measuring ring to pinion gear backlash at several locations around the ring gear. Readings should not vary more than 0.05 mm (0.002 in.). If readings vary more than specified, the ring gear or the differential case is defective.

After the proper backlash is achieved, perform Gear Contact Pattern Analysis procedure.

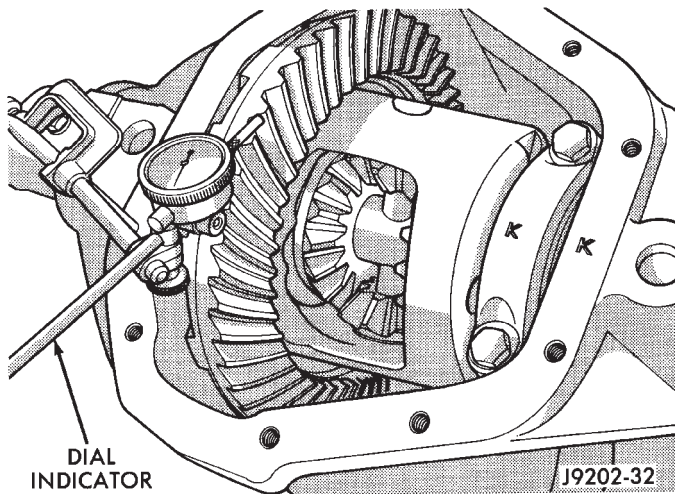


Fig. 76 Ring Gear Backlash Measurement

GEAR CONTACT PATTERN ANALYSIS

The ring and pinion gear teeth contact patterns will show if the pinion gear depth is correct in the axle housing. It will also show if the ring gear backlash has been adjusted correctly. The backlash can be adjusted within specifications to achieve desired tooth contact patterns.

(1) Apply a thin coat of hydrated ferric oxide, or equivalent, to the drive and coast side of the ring gear teeth.

(2) Wrap, twist, and hold a shop towel around the pinion yoke to increase the turning resistance of the pinion gear. This will provide a more distinct contact pattern.

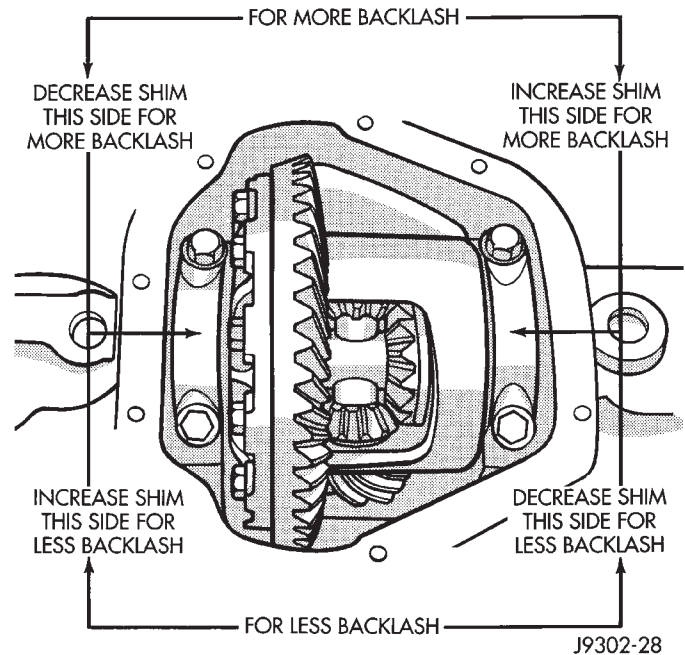
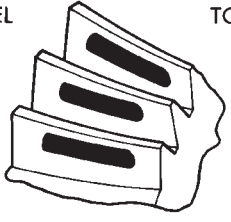
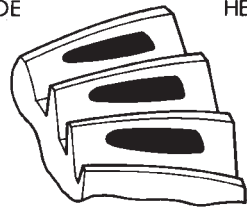
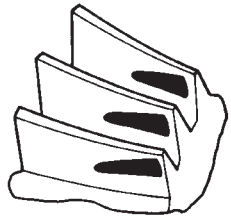
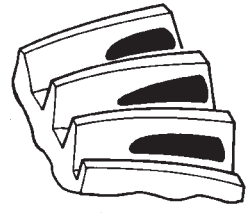
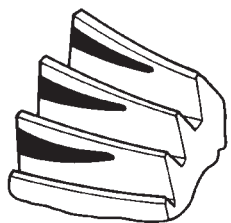
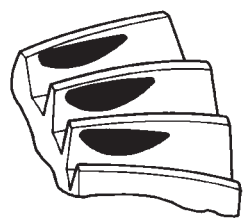
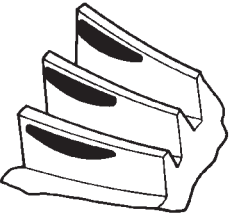
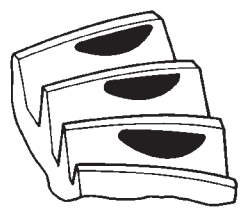
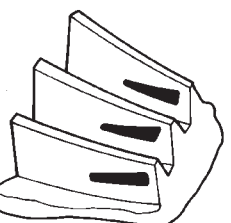
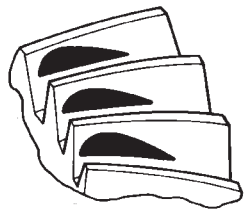


Fig. 77 Backlash Shim Adjustment

(3) Using a boxed end wrench on a ring gear bolt, rotate the differential case one complete revolution in both directions while a load is being applied from shop towel.

The areas on the ring gear teeth with the greatest degree of contact against the pinion gear teeth will squeegee the compound to the areas with the least amount of contact. Note and compare patterns on the ring gear teeth to Gear Tooth Contact Patterns chart (Fig. 78) and adjust pinion depth and gear backlash as necessary.

ADJUSTMENTS (Continued)

<p>DRIVE SIDE OF RING GEAR TEETH</p> <p>HEEL TOE</p> 	<p>COAST SIDE OF RING GEAR TEETH</p> <p>TOE HEEL</p> 	<p>DESIRABLE CONTACT PATTERN. PATTERN SHOULD BE CENTERED ON THE DRIVE SIDE OF TOOTH. PATTERN SHOULD BE CENTERED ON THE COAST SIDE OF TOOTH, BUT MAY BE SLIGHTLY TOWARD THE TOE. THERE SHOULD ALWAYS BE SOME CLEARANCE BETWEEN CONTACT PATTERN AND TOP OF THE TOOTH.</p>
		<p>RING GEAR BACKLASH CORRECT. THINNER PINION GEAR DEPTH SHIM REQUIRED.</p>
		<p>RING GEAR BACKLASH CORRECT. THICKER PINION GEAR DEPTH SHIM REQUIRED.</p>
		<p>PINION GEAR DEPTH SHIM CORRECT. DECREASE RING GEAR BACKLASH.</p>
		<p>PINION GEAR DEPTH SHIM CORRECT. INCREASE RING GEAR BACKLASH.</p>

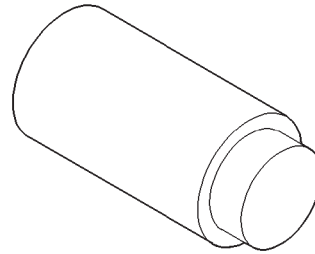
J9003-24

Fig. 78 Gear Tooth Contact Patterns

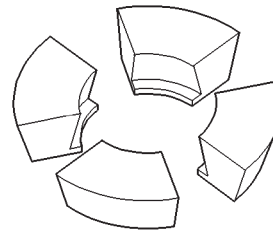
SPECIFICATIONS

181 FBI AXLE

Axle TypeHypoid
 Lubricant.SAE Thermally Stable 80W-90
 Lube Capacity1.2 L (2.5 pts.)
 Axle Ratio3.07, 3.55, 3.73, 4.10
 Differential Side Gear Clearance0.12-0.20 mm
 (0.005-0.008 in.)
 Ring Gear Diameter18.09 cm (7.125 in.)
 Backlash0-0.15 mm (0.005-0.008 in.)
 Pinion Std. Depth92.1 mm (3.625 in.)
 Pinion Bearing Rotating Torque
 Original Bearings1-2 N·m (10-20 in. lbs.)
 New Bearings1.5-4 N·m (15-35 in. lbs.)



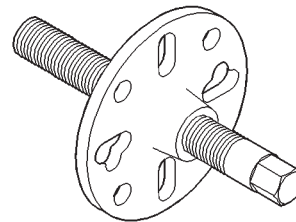
Plug—SP-3289



Adapter—C-293-39

181 FBI AXLE

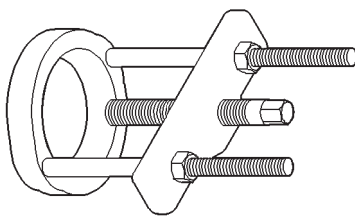
DESCRIPTION	TORQUE
Fill Hole Plug34 N·m (25 ft. lbs.)
Diff. Cover Bolt41 N·m (30 ft. lbs.)
Bearing Cap Bolt61 N·m (45 ft. lbs.)
Ring Gear Bolt95-122 N·m (70-90 ft. lbs.)
Axle Nut237 N·m (175 ft. lbs.)
Hub Brg. Bolt102 N·m (75 ft. lbs.)
Lower Ball Stud108 N·m (80 ft. lbs.)
Upper Ball Stud101 N·m (75 ft. lbs.)



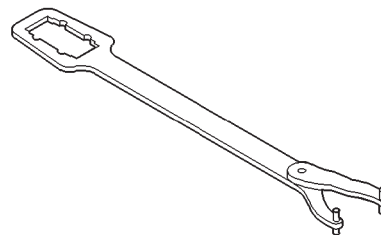
Puller—C-452

SPECIAL TOOLS

181 FBI AXLE

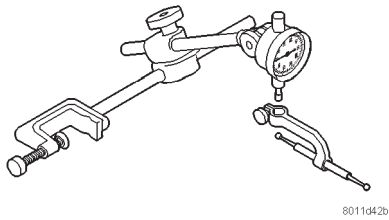


Puller—C-293-PA

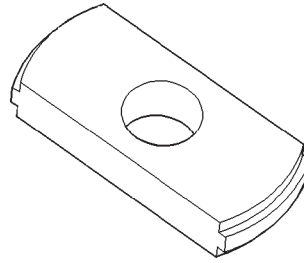


Wrench—C-3281

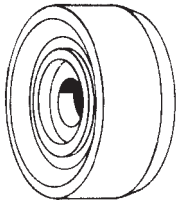
SPECIAL TOOLS (Continued)



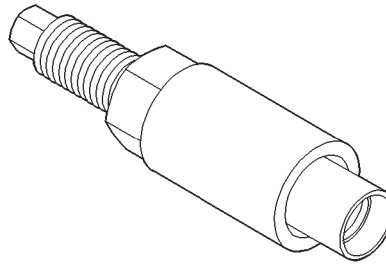
Dial Indicator—C-3339



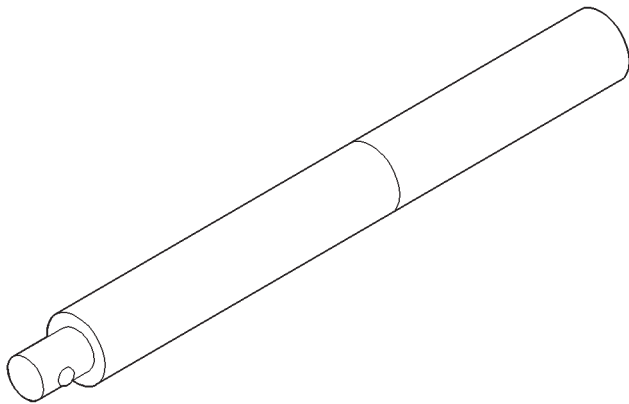
Remover—D-149



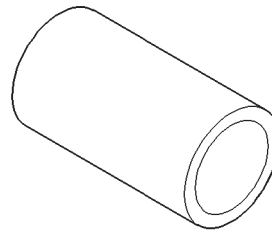
Driver—C-3716-A



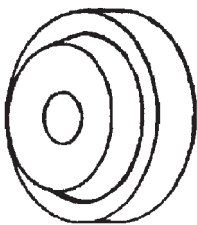
Installer—W-162-D



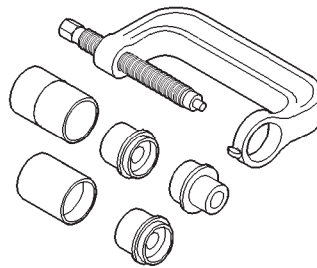
Handle—C-4171



Cup—8109

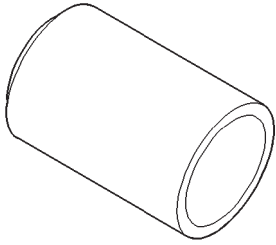


Installer—D-146

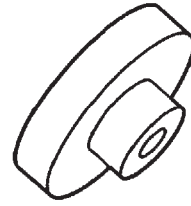


Remover/Installer—6289

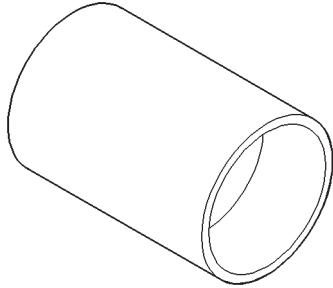
SPECIAL TOOLS (Continued)



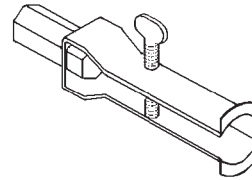
Installer—6761



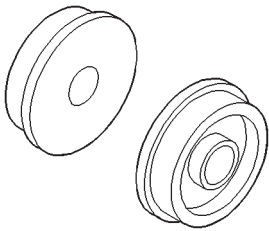
Gauge Block—6733



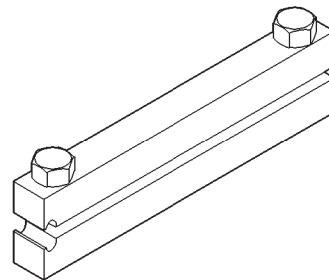
Installer—6752



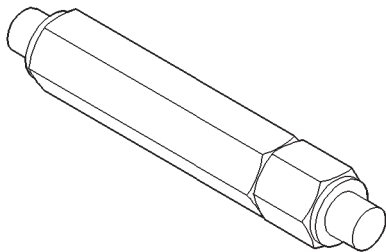
Puller—7794-A



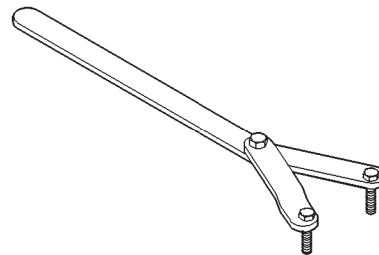
Installer Discs—8110



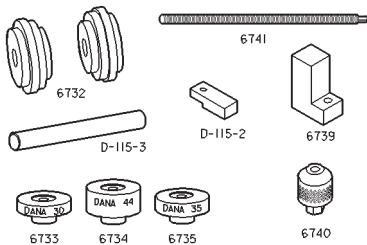
Installer—C-4975-A



Turnbuckle—6797

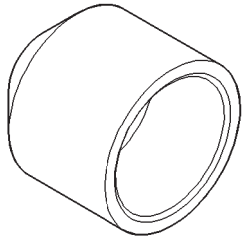


Spanner—6958

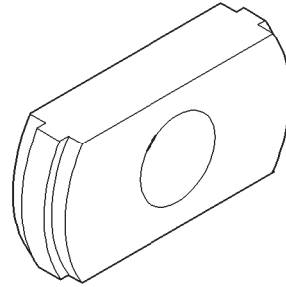


Tool Set, Pinion Depth—6774

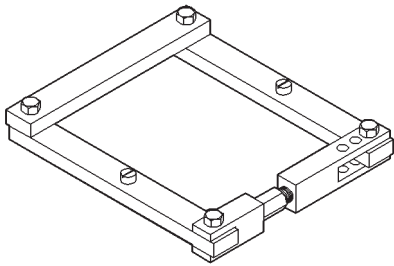
SPECIAL TOOLS (Continued)



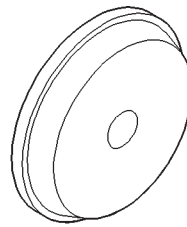
Installer—C-3972-A



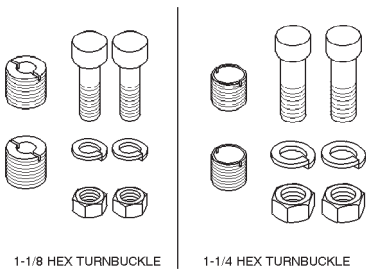
Remover—C-4345



Spreader—W-129-B



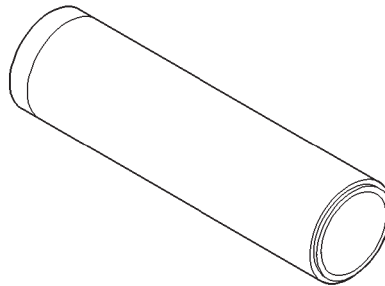
Installer—D-130



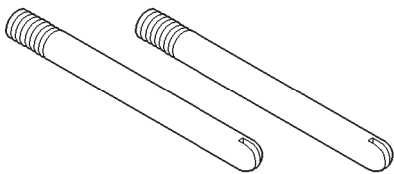
1-1/8 HEX TURNBUCKLE

1-1/4 HEX TURNBUCKLE

Adapter Kit—6987



Installer—W-262



Pilot Stud—C-3288-B

194 RBI AXLE

INDEX

	page		page
GENERAL INFORMATION		DIFFERENTIAL	65
194 RBI AXLE	52	FINAL ASSEMBLY	72
LUBRICANT SPECIFICATIONS	52	PINION GEAR	68
DESCRIPTION AND OPERATION		PINION SHAFT SEAL	59
STANDARD DIFFERENTIAL	53	REAR AXLE	58
TRAC-LOK OPERATION	53	RING GEAR	67
DIAGNOSIS AND TESTING		DISASSEMBLY AND ASSEMBLY	
BEARING NOISE	54	STANDARD DIFFERENTIAL	73
DRIVELINE SNAP	55	TRAC-LOK DIFFERENTIAL	73
GEAR NOISE	54	CLEANING AND INSPECTION	
GENERAL INFORMATION	54	AXLE COMPONENTS	77
LOW SPEED KNOCK	55	TRAC-LOK	78
TRAC-LOK DIFFERENTIAL NOISE	55	ADJUSTMENTS	
TRAC-LOK TEST	58	DIFFERENTIAL BEARING PRELOAD AND	
VIBRATION	55	GEAR BACKLASH	80
SERVICE PROCEDURES		GEAR CONTACT PATTERN ANALYSIS	82
LUBRICANT CHANGE	58	PINION GEAR DEPTH	78
REMOVAL AND INSTALLATION		SPECIFICATIONS	
AXLE SHAFT SEAL AND BEARING	64	194 RBI AXLE	84
AXLE SHAFT	64	194 RBI AXLE	84
COLLAPSIBLE SPACER	61	SPECIAL TOOLS	
DIFFERENTIAL SIDE BEARINGS	67	194 RBI AXLE	84

GENERAL INFORMATION

194 RBI AXLE

The 194 Rear Beam-design Iron (RBI) axle housing has an iron center casting (differential housing) with axle shaft tubes extending from either side. The tubes are pressed into and welded to the differential housing to form a one-piece axle housing.

The integral type, hypoid gear design, housing has the centerline of the pinion set below the centerline of the ring gear.

The axle has a vent hose to relieve internal pressure caused by lubricant vaporization and internal expansion.

The axles are equipped with semi-floating axle shafts, meaning that loads are supported by the axle shaft and bearings. The axle shafts are retained by C-clips in the differential side gears.

The cover provides a means for servicing the differential without removing the axle.

For vehicles equipped with ABS brakes, the axles have a tone ring pressed onto the axle shaft. Use care when removing axle shafts to ensure that the tone wheel or the wheel speed sensor are not damaged.

The 194 RBI axle has the assembly part number and gear ratio listed on a tag. The tag is attached to the differential housing by a cover bolt. Build date identification codes are stamped on the cover side of an axle shaft tube.

The differential case is a one-piece design. The differential pinion mate shaft is retained with a threaded pin. Differential bearing preload and ring gear backlash is adjusted by the use of selective spacer shims. Pinion bearing preload is set and maintained by the use of a collapsible spacer (Fig. 1).

LUBRICANT SPECIFICATIONS

A multi-purpose, hypoid gear lubricant which conforms to the following specifications should be used. Mopar® Hypoid Gear Lubricant conforms to all of these specifications.

- The lubricant should have MIL-L-2105C and API GL 5 quality specifications.
- Lubricant is a thermally stable SAE 80W-90 gear lubricant.
- Lubricant for axles intended for heavy-duty or trailer tow use is SAE 75W-140 SYNTHETIC gear lubricant.

Trac-lok differentials require the addition of 4 oz. of friction modifier to the axle lubricant. The 194 RBI

GENERAL INFORMATION (Continued)

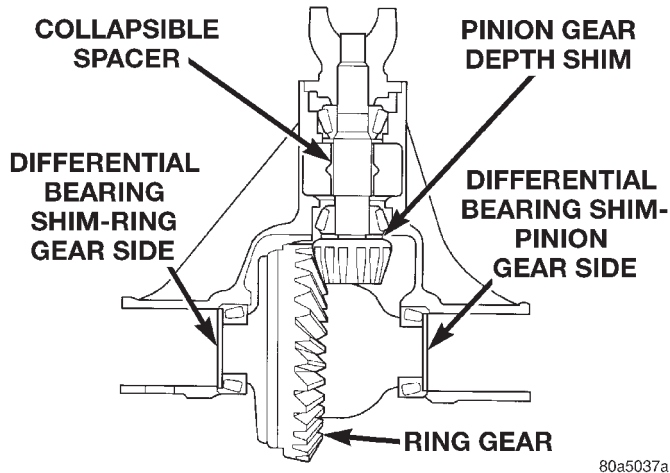


Fig. 1 Shim Locations

axle lubricant capacity is 1.66L (3.50 pts.) total, including the friction modifier if necessary.

CAUTION: If axle is submerged in water, lubricant must be replaced immediately to avoid possible premature axle failure.

DESCRIPTION AND OPERATION

STANDARD DIFFERENTIAL

The differential gear system divides the torque between the axle shafts. It allows the axle shafts to rotate at different speeds when turning corners.

Each differential side gear is splined to an axle shaft. The pinion gears are mounted on a pinion mate shaft and are free to rotate on the shaft. The pinion gear is fitted in a bore in the differential case and is positioned at a right angle to the axle shafts.

In operation, power flow occurs as follows:

- The pinion gear rotates the ring gear
- The ring gear (bolted to the differential case) rotates the case
- The differential pinion gears (mounted on the pinion mate shaft in the case) rotate the side gears
- The side gears (splined to the axle shafts) rotate the shafts

During straight-ahead driving, the differential pinion gears do not rotate on the pinion mate shaft. This occurs because input torque applied to the gears is divided and distributed equally between the two side gears. As a result, the pinion gears revolve with the pinion mate shaft but do not rotate around it (Fig. 2).

When turning corners, the outside wheel must travel a greater distance than the inside wheel to complete a turn. The difference must be compensated for to prevent the tires from scuffing and skidding through turns. To accomplish this, the differential allows the axle shafts to turn at unequal speeds (Fig.

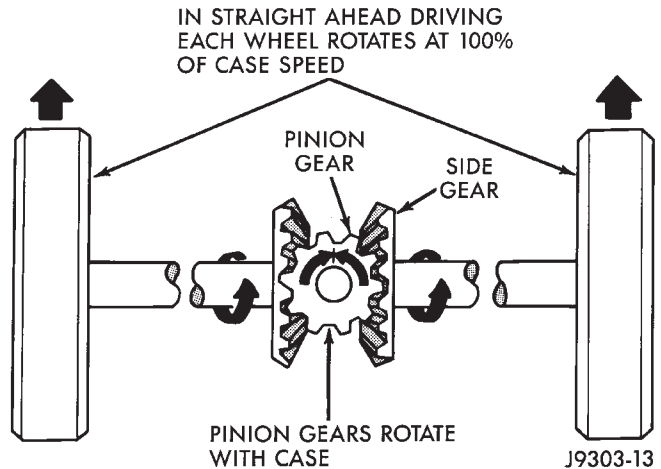


Fig. 2 Differential Operation—Straight Ahead Driving

3). In this instance, the input torque applied to the pinion gears is not divided equally. The pinion gears now rotate around the pinion mate shaft in opposite directions. This allows the side gear and axle shaft attached to the outside wheel to rotate at a faster speed.

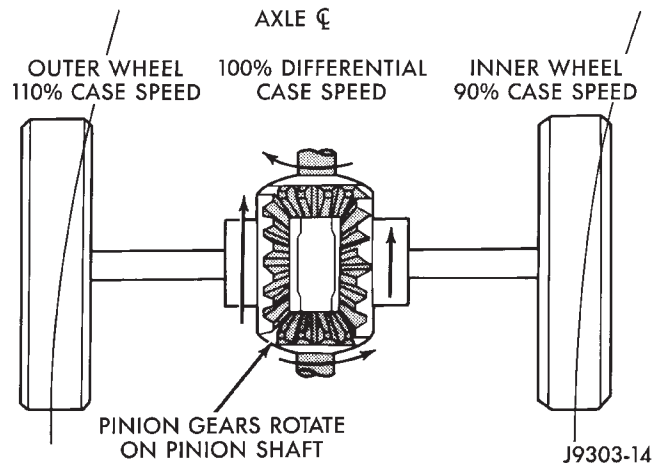


Fig. 3 Differential Operation—On Turns

TRAC-LOK OPERATION

In a conventional differential, if one wheel spins, the opposite wheel will generate only as much torque as the spinning wheel.

In the Trac-lok differential, part of the ring gear torque is transmitted through clutch packs which contain multiple discs. The clutches will have radial grooves on the plates, and concentric grooves on the discs or bonded fiber material that is smooth in appearance.

In operation, the Trac-lok clutches are engaged by two concurrent forces. The first being the preload force exerted through Belleville spring washers within the clutch packs. The second is the separating forces generated by the side gears as torque is applied through the ring gear (Fig. 4).

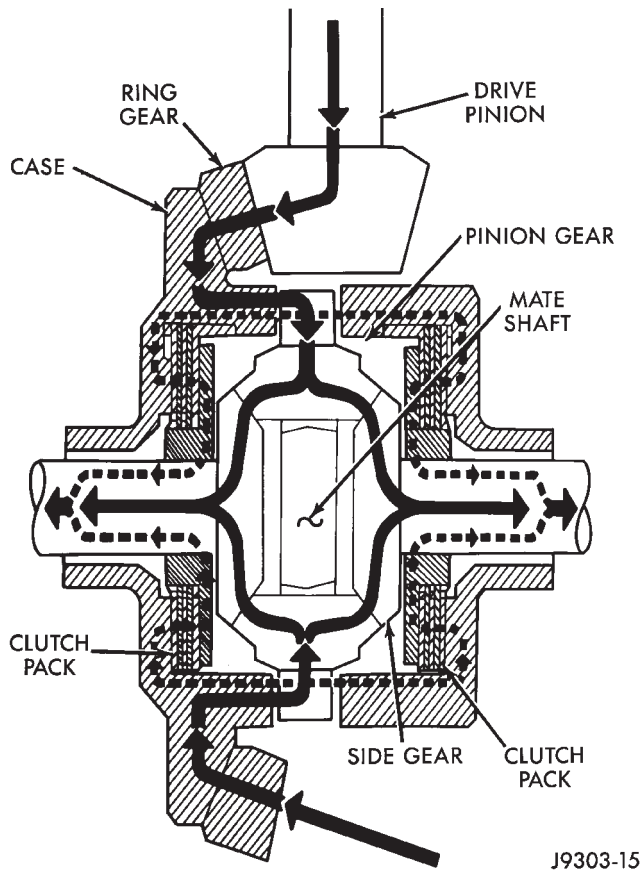
DESCRIPTION AND OPERATION (Continued)

Fig. 4 Trac-lok Limited Slip Differential Operation

The Trac-lok design provides the differential action needed for turning corners and for driving straight ahead during periods of unequal traction. When one wheel loses traction, the clutch packs transfer additional torque to the wheel having the most traction. Trac-lok differentials resist wheel spin on bumpy roads and provide more pulling power when one wheel loses traction. Pulling power is provided continuously until both wheels lose traction. If both wheels slip due to unequal traction, Trac-lok operation is normal. In extreme cases of differences of traction, the wheel with the least traction may spin.

DIAGNOSIS AND TESTING**GENERAL INFORMATION**

Axle bearing problem conditions are usually caused by:

- Insufficient or incorrect lubricant.
- Foreign matter/water contamination.
- Incorrect bearing preload torque adjustment.
- Incorrect backlash.

Axle gear problem conditions are usually the result of:

- Insufficient lubrication.
- Incorrect or contaminated lubricant.

- Overloading (excessive engine torque) or exceeding vehicle weight capacity.

- Incorrect clearance or backlash adjustment.

Axle component breakage is most often the result of:

- Severe overloading.
- Insufficient lubricant.
- Incorrect lubricant.
- Improperly tightened components.

GEAR NOISE

Axle gear noise can be caused by insufficient lubricant, incorrect backlash, tooth contact, or worn/damaged gears.

Gear noise usually happens at a specific speed range. The range is 30 to 40 mph, or above 50 mph. The noise can also occur during a specific type of driving condition. These conditions are acceleration, deceleration, coast, or constant load.

When road testing, accelerate the vehicle to the speed range where the noise is the greatest. Shift out-of-gear and coast through the peak-noise range. If the noise stops or changes greatly:

- Check for insufficient lubricant.
- Incorrect ring gear backlash.
- Gear damage.

Differential side and pinion gears can be checked by turning the vehicle. They usually do not cause noise during straight-ahead driving when the gears are unloaded. The side gears are loaded during vehicle turns. A worn pinion gear mate shaft can also cause a snapping or a knocking noise.

BEARING NOISE

The axle shaft, differential and pinion gear bearings can all produce noise when worn or damaged. Bearing noise can be either a whining, or a growling sound.

Pinion gear bearings have a constant-pitch noise. This noise changes only with vehicle speed. Pinion bearing noise will be higher because it rotates at a faster rate. Drive the vehicle and load the differential. If bearing noise occurs, the rear pinion bearing is the source of the noise. If the bearing noise is heard during a coast, the front pinion bearing is the source.

Worn or damaged differential bearings usually produce a low pitch noise. Differential bearing noise is similar to pinion bearing noise. The pitch of differential bearing noise is also constant and varies only with vehicle speed.

Axle shaft bearings produce noise and vibration when worn or damaged. The noise generally changes when the bearings are loaded. Road test the vehicle. Turn the vehicle sharply to the left and to the right. This will load the bearings and change the noise

DIAGNOSIS AND TESTING (Continued)

level. Where axle bearing damage is slight, the noise is usually not noticeable at speeds above 30 mph.

LOW SPEED KNOCK

Low speed knock is generally caused by a worn U-joint or by worn side-gear thrust washers. A worn pinion gear shaft bore will also cause low speed knock.

VIBRATION

Vibration at the rear of the vehicle is usually caused by a:

- Damaged drive shaft.
- Missing drive shaft balance weight(s).
- Worn or out-of-balance wheels.
- Loose wheel lug nuts.
- Worn U-joint(s).
- Loose/broken springs.
- Damaged axle shaft bearing(s).
- Loose pinion gear nut.
- Excessive pinion yoke run out.
- Bent axle shaft(s).

Check for loose or damaged front-end components or engine/transmission mounts. These components can contribute to what appears to be a rear-end vibration. Do not overlook engine accessories, brackets and drive belts.

All driveline components should be examined before starting any repair.

Refer to Group 22, Wheels and Tires, for additional vibration information.

DRIVELINE SNAP

A snap or clunk noise when the vehicle is shifted into gear (or the clutch engaged), can be caused by:

- High engine idle speed
- Loose engine/transmission/transfer case mounts
- Worn U-joints
- Loose spring mounts
- Loose pinion gear nut and yoke
- Excessive ring gear backlash
- Excessive side gear/case clearance

The source of a snap or a clunk noise can be determined with the assistance of a helper. Raise the vehicle on a hoist with the wheels free to rotate. Instruct the helper to shift the transmission into gear. Listen for the noise, a mechanics stethoscope is helpful in isolating the source of a noise.

TRAC-LOK DIFFERENTIAL NOISE

The most common problem is a chatter noise when turning corners. Before removing a Trac-lok unit for repair, drain, flush and refill the axle with the specified lubricant. Refer to Lubricant change in this Group.

A container of Mopar® Trac-lok Lubricant (friction modifier) should be added after repair service or during a lubricant change.

After changing the lubricant, drive the vehicle and make 10 to 12 slow, figure-eight turns. This maneuver will pump lubricant through the clutches. This will correct the condition in most instances. If the chatter persists, clutch damage could have occurred.

DIAGNOSIS AND TESTING (Continued)

DIAGNOSIS CHART

CONDITION	POSSIBLE CAUSES	CORRECTION
WHEEL NOISE	<ol style="list-style-type: none"> 1. Wheel loose. 2. Faulty, brinelled wheel bearing. 	<ol style="list-style-type: none"> 1. Tighten loose nuts. 2. Faulty or brinelled bearings must be replaced.
AXLE SHAFT NOISE	<ol style="list-style-type: none"> 1. Misaligned axle shaft tube. 2. Bent or sprung axle shaft. 3. End play in drive pinion bearings. 4. Excessive gear backlash between ring gear and pinion gear. 5. Improper adjustment of drive pinion gear shaft bearings. 6. Loose drive pinion gearshaft yoke nut. 7. Improper wheel bearing adjustment. 8. Scuffed gear tooth contact surfaces. 	<ol style="list-style-type: none"> 1. Inspect axle shaft tube alignment. Correct as necessary. 2. Replace bent or sprung axle shaft. 3. Refer to Drive Pinion Bearing Pre-Load Adjustment. 4. Check adjustment of ring gear backlash and pinion gear. Correct as necessary. 5. Adjust drive pinion shaft bearings. 6. Tighten drive pinion gearshaft yoke nut with specified torque. 7. Readjust as necessary. 8. If necessary, replace scuffed gears.
AXLE SHAFT BROKE	<ol style="list-style-type: none"> 1. Misaligned axle shaft tube. 2. Vehicle overloaded. 3. Erratic clutch operation. 4. Grabbing clutch. 	<ol style="list-style-type: none"> 1. Replace broken axle shaft after correcting axle shaft tube alignment. 2. Replace broken axle shaft. Avoid excessive weight on vehicle. 3. Replace broken axle shaft after inspecting for other possible causes. Avoid erratic use of clutch. 4. Replace broken axle shaft. Inspect clutch and make necessary repairs or adjustments.
DIFFERENTIAL CASE CRACKED	<ol style="list-style-type: none"> 1. Improper adjustment of differential bearings. 2. Excessive ring gear backlash. 3. Vehicle overloaded. 4. Erratic clutch operation. 	<ol style="list-style-type: none"> 1. Replace cracked case; examine gears and bearings for possible damage. At reassembly, adjust differential bearings properly. 2. Replace cracked case; examine gears and bearings for possible damage. At reassembly, adjust ring gear backlash properly. 3. Replace cracked case; examine gears and bearings for possible damage. Avoid excessive weight on vehicle. 4. Replace cracked case. After inspecting for other possible causes, examine gears and bearings for possible damage. Avoid erratic use of clutch.
DIFFERENTIAL GEARS SCORED	<ol style="list-style-type: none"> 1. Insufficient lubrication. 2. Improper grade of lubricant. 3. Excessive spinning of one wheel/tire. 	<ol style="list-style-type: none"> 1. Replace scored gears. Scoring marks on the drive face of gear teeth or in the bore are caused by instantaneous fusing of the mating surfaces. Scored gears should be replaced. Fill rear differential housing to required capacity with proper lubricant. Refer to Specifications. 2. Replace scored gears. Inspect all gears and bearings for possible damage. Clean and refill differential housing to required capacity with proper lubricant. 3. Replace scored gears. Inspect all gears, pinion bores and shaft for damage. Service as necessary.
LOSS OF LUBRICANT	<ol style="list-style-type: none"> 1. Lubricant level too high. 	<ol style="list-style-type: none"> 1. Drain excess lubricant by removing fill plug and allow lubricant to level at lower edge of fill plug hole.

DIAGNOSIS AND TESTING (Continued)

CONT., DIAGNOSIS CHART

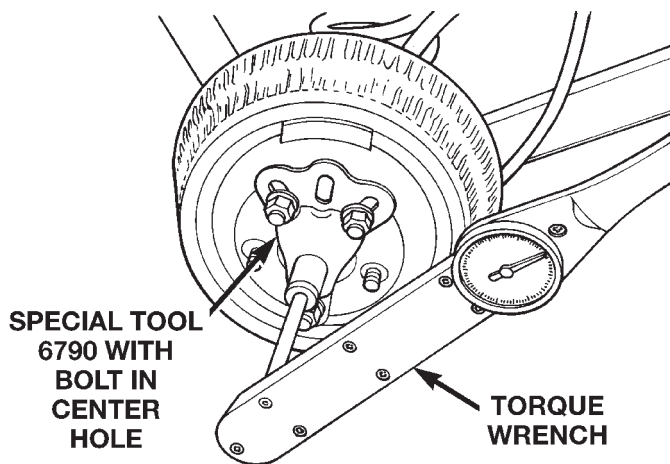
CONDITION	POSSIBLE CAUSES	CORRECTION
LOSS OF LUBRICANT	2. Worn axle shaft seals. 3. Cracked differential housing. 4. Worn drive pinion gear shaft seal. 5. Scored and worn yoke. 6. Axle cover not properly sealed.	2. Replace worn seals. 3. Repair or replace housing as necessary. 4. Replace worn drive pinion gear shaft seal. 5. Replace worn or scored yoke and seal. 6. Remove cover and clean flange and reseal.
AXLE OVERHEATING	1. Lubricant level too low. 2. Incorrect grade of lubricant. 3. Bearings adjusted too tight. 4. Excessive gear wear. 5. Insufficient ring gear backlash.	1. Refill differential housing. 2. Drain, flush and refill with correct amount of the correct lubricant. 3. Readjust bearings. 4. Inspect gears for excessive wear or scoring. Replace as necessary. 5. Readjust ring gear backlash and inspect gears for possible scoring.
GEAR TEETH BROKE (RING GEAR AND PINION)	1. Overloading. 2. Erratic clutch operation. 3. Ice-spotted pavements. 4. Improper adjustments.	1. Replace gears. Examine other gears and bearings for possible damage. 2. Replace gears and examine the remaining parts for possible damage. Avoid erratic clutch operation. 3. Replace gears. Examine the remaining parts for possible damage. Replace parts as required. 4. Replace gears. Examine other parts for possible damage. Ensure ring gear backlash is correct.
AXLE NOISE	1. Insufficient lubricant. 2. Improper ring gear and drive pinion gear adjustment. 3. Unmatched ring gear and drive pinion gear. 4. Worn teeth on ring gear or drive pinion gear. 5. Loose drive pinion gear shaft bearings. 6. Loose differential bearings. 7. Misaligned or sprung ring gear. 8. Loose differential bearing cap bolts	1. Refill axle with correct amount of the proper lubricant. Also inspect for leaks and correct as necessary. 2. Check ring gear and pinion gear teeth contact pattern. 3. Remove unmatched ring gear and drive pinion gear. Replace with matched gear and drive pinion gear set. 4. Check teeth on ring gear and drive pinion gear for correct contact. If necessary, replace with new matched set. 5. Adjust drive pinion gearshaft bearing preload torque. 6. Adjust differential bearing preload torque. 7. Measure ring gear runout. 8. Tighten with specified torque

DIAGNOSIS AND TESTING (Continued)**TRAC-LOK TEST**

WARNING: WHEN SERVICING VEHICLES WITH A TRAC-LOK DIFFERENTIAL DO NOT USE THE ENGINE TO TURN THE AXLE AND WHEELS. BOTH REAR WHEELS MUST BE RAISED AND THE VEHICLE SUPPORTED. A TRAC-LOK AXLE CAN EXERT ENOUGH FORCE IF ONE WHEEL IS IN CONTACT WITH A SURFACE TO CAUSE THE VEHICLE TO MOVE.

The differential can be tested without removing the differential case by measuring rotating torque. Make sure brakes are not dragging during this measurement.

- (1) Place blocks in front and rear of both front wheels.
- (2) Raise one rear wheel until it is completely off the ground.
- (3) Engine off, transmission in neutral, and parking brake off.
- (4) Remove wheel and bolt Special Tool 6790 to studs.
- (5) Use torque wrench on special tool to rotate wheel and read rotating torque (Fig. 5).



80a4d327

Fig. 5 Trac-lok Test – Typical

- (6) If rotating torque is less than 22 N·m (30 ft. lbs.) or more than 271 N·m (200 ft. lbs.) on either wheel the unit should be serviced.

SERVICE PROCEDURES**LUBRICANT CHANGE**

- (1) Raise and support the vehicle.
- (2) Remove the lubricant fill hole plug from the differential housing cover.
- (3) Remove the differential housing cover and drain the lubricant from the housing.

- (4) Clean the housing cavity with a flushing oil, light engine oil, or lint free cloth. **Do not use water, steam, kerosene, or gasoline for cleaning.**

- (5) Remove the original sealant from the housing and cover surfaces.

- (6) Apply a bead of Mopar® Silicone Rubber Sealant, or equivalent, to the housing cover (Fig. 6).

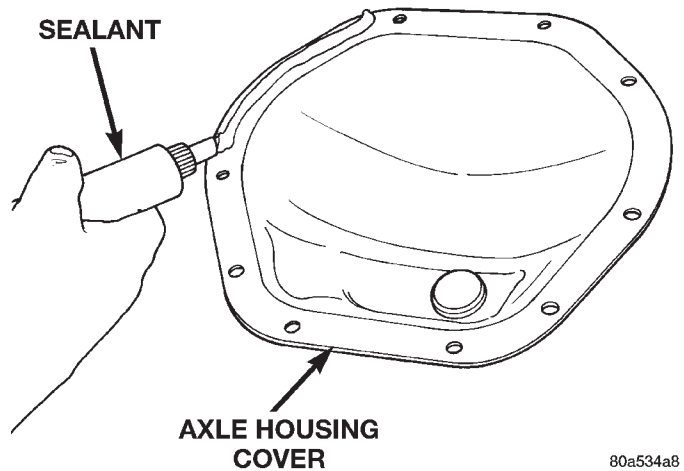


Fig. 6 Apply Sealant

Install the housing cover within 5 minutes after applying the sealant.

- (7) Install the cover and any identification tag. Tighten the cover bolts to 41 N·m (30 ft. lbs.) torque.

- (8) For Trac-lok differentials, a quantity of Mopar® Trac-lok lubricant (friction modifier), or equivalent, must be added after repair service or a lubricant change. Refer to the Lubricant Specifications section of this group for the quantity necessary.

- (9) Fill differential with Mopar® Hypoid Gear Lubricant, or equivalent, to bottom of the fill plug hole. Refer to the Lubricant Specifications section of this group for the quantity necessary.

CAUTION: Overfilling the differential can result in lubricant foaming and overheating.

- (10) Install the fill hole plug and lower the vehicle.

- (11) Trac-lok differential equipped vehicles should be road tested by making 10 to 12 slow figure-eight turns. This maneuver will pump the lubricant through the clutch discs to eliminate a possible chatter noise complaint.

REMOVAL AND INSTALLATION**REAR AXLE****REMOVAL**

- (1) Raise and support the vehicle.

REMOVAL AND INSTALLATION (Continued)

- (2) Position a suitable lifting device under the axle.
- (3) Secure axle to device.
- (4) Remove the wheels and tires.
- (5) Remove the brake rotors and calipers from the axle. Refer to Group 5, Brakes, for proper procedures.
- (6) Disconnect parking brake cables from brackets and lever.
- (7) Remove wheel speed sensors, if necessary. Refer to Group 5, Brakes, for proper procedures.
- (8) Disconnect the brake hose at the axle junction block. Do not disconnect the brake hydraulic lines at the calipers. Refer to Group 5, Brakes, for proper procedures.
- (9) Disconnect the vent hose from the axle shaft tube.
- (10) Mark the propeller shaft and yokes for installation alignment reference.
- (11) Remove propeller shaft.
- (12) Disconnect stabilizer bar links.
- (13) Disconnect shock absorbers from axle.
- (14) Disconnect track bar.
- (15) Disconnect upper and lower suspension arms from the axle brackets.
- (16) Separate the axle from the vehicle.

INSTALLATION

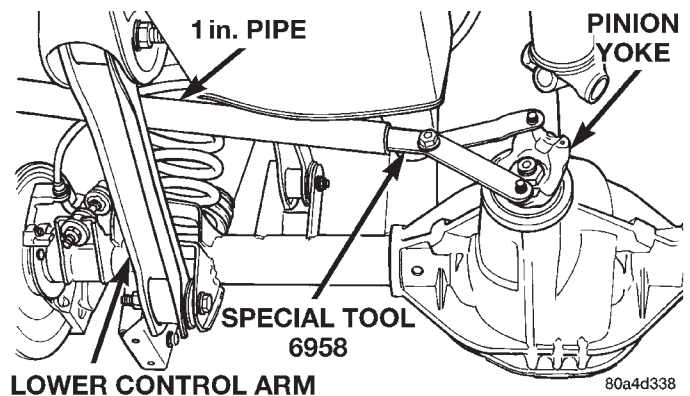
NOTE: The weight of the vehicle must be supported by the springs before suspension arms and track bar fasteners can be tightened. If the springs are not at their normal ride position, vehicle ride height and handling could be affected.

- (1) Raise the axle with lifting device and align coil springs.
- (2) Position the upper and lower suspension arms on the axle brackets. Install nuts and bolts, do not tighten bolts at this time.
- (3) Install track bar and attachment bolts, do not tighten bolts at this time.
- (4) Install shock absorbers and tighten nuts to 60 N·m (44 ft. lbs.) torque.
- (5) Install stabilizer bar links and tighten nuts to 36 N·m (27 ft. lbs.) torque.
- (6) Install the wheel speed sensors, if necessary. Refer to Group 5, Brakes, for proper procedures.
- (7) Connect parking brake cable to brackets and lever.
- (8) Install the brake rotors and calipers. Refer to Group 5, Brakes, for proper procedures.
- (9) Connect the brake hose to the axle junction block. Refer to Group 5, Brakes, for proper procedures.
- (10) Install axle vent hose.

- (11) Align propeller shaft and pinion yoke reference marks. Install U-joint straps and bolts. Tighten to 19 N·m (14 ft. lbs.) torque.
- (12) Install the wheels and tires.
- (13) Add gear lubricant, if necessary. Refer to Lubricant Specifications in this section for lubricant requirements.
- (14) Remove lifting device from axle and lower the vehicle.
- (15) Tighten lower suspension arm bolts to 177 N·m (130 ft. lbs.) torque.
- (16) Tighten upper suspension arm bolts to 75 N·m (55 ft. lbs.) torque.
- (17) Tighten track bar bolts to 100 N·m (74 ft. lbs.) torque.

PINION SHAFT SEAL**REMOVAL**

- (1) Raise and support the vehicle.
- (2) Remove wheel and tire assemblies.
- (3) Remove the brake rotors and calipers. Refer to Group 5, Brakes, for proper procedures.
- (4) Mark the propeller shaft and pinion yoke for installation alignment reference.
- (5) Remove the propeller shaft from the yoke.
- (6) Rotate the pinion gear three or four times.
- (7) Measure the amount of torque necessary to rotate the pinion gear with a (in. lbs.) dial-type torque wrench. Record the torque reading for installation reference.
- (8) Using a short piece of pipe and Holder 6958 to hold the pinion yoke, remove the pinion nut and washer (Fig. 7).
- (9) Use Remover C-452 and Wrench C-3281 to remove the pinion yoke (Fig. 8).

**Fig. 7 Pinion Yoke Holder**

- (10) Use Remover 7794-A and slide hammer to remove the pinion gear seal (Fig. 9).

REMOVAL AND INSTALLATION (Continued)

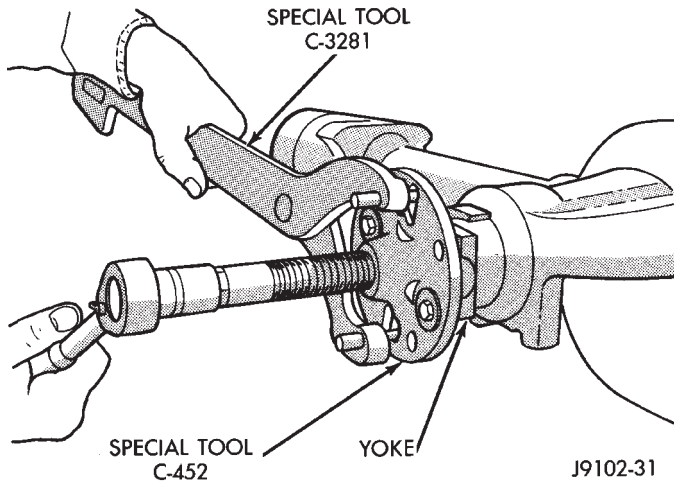


Fig. 8 Pinion Yoke Removal

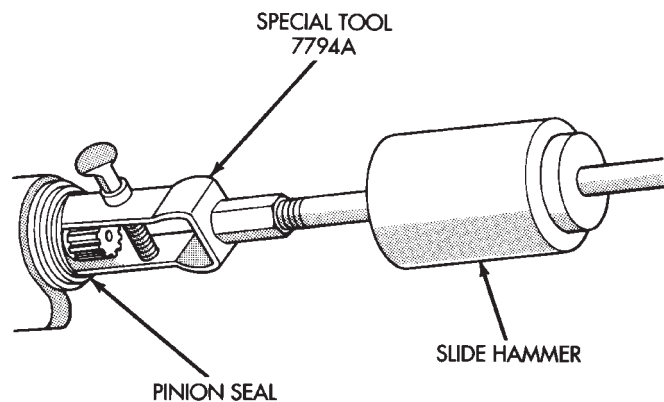


Fig. 9 Seal Removal

INSTALLATION

(1) Apply a light coating of gear lubricant on the lip of pinion seal. Install seal with Installer C-3972-A and Handle C-4171 (Fig. 10).

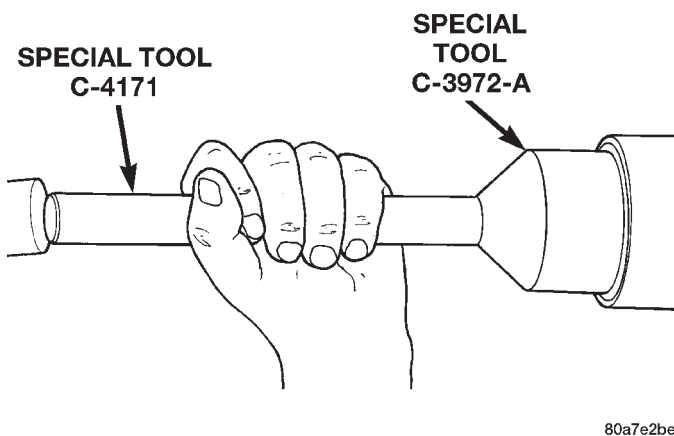


Fig. 10 Pinion Seal Installation

(2) Install yoke on the pinion gear with Screw 8112, Cup 8109, and Holder 6958 (Fig. 11).

CAUTION: Do not exceed the minimum tightening torque when installing the pinion yoke at this point. Damage to the collapsible spacer or bearings may result.

(3) Install the yoke washer and a new nut on the pinion gear and tighten the pinion nut until there is zero bearing end-play.

(4) Tighten the nut to 271 N·m (200 ft. lbs.).

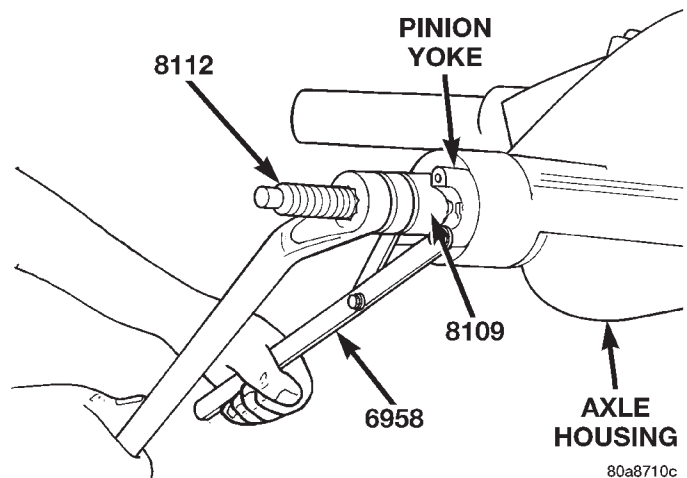


Fig. 11 Pinion Yoke Installation

CAUTION: Never loosen pinion gear nut to decrease pinion gear bearing rotating torque and never exceed specified preload torque. If preload torque or rotating torque is exceeded a new collapsible spacer must be installed. The torque sequence will then have to be repeated.

(5) Rotate the pinion shaft using a (in. lbs.) torque wrench. Rotating torque should be equal to the reading recorded during removal plus an additional 0.56 N·m (5 in. lbs.) (Fig. 12).

(6) If the rotating torque is low, use Holder 6958 to hold the pinion yoke (Fig. 13), and tighten the pinion shaft nut in 6.8 N·m (5 ft. lbs.) increments until the proper rotating torque is achieved.

CAUTION: If the maximum tightening torque is reached prior to reaching the required rotating torque, the collapsible spacer may have been damaged. Replace the collapsible spacer.

(7) Align the installation reference marks on the propeller shaft and yoke and install the propeller shaft.

(8) Add gear lubricant to the differential housing, if necessary. Refer to the Lubricant Specifications for gear lubricant requirements.

REMOVAL AND INSTALLATION (Continued)

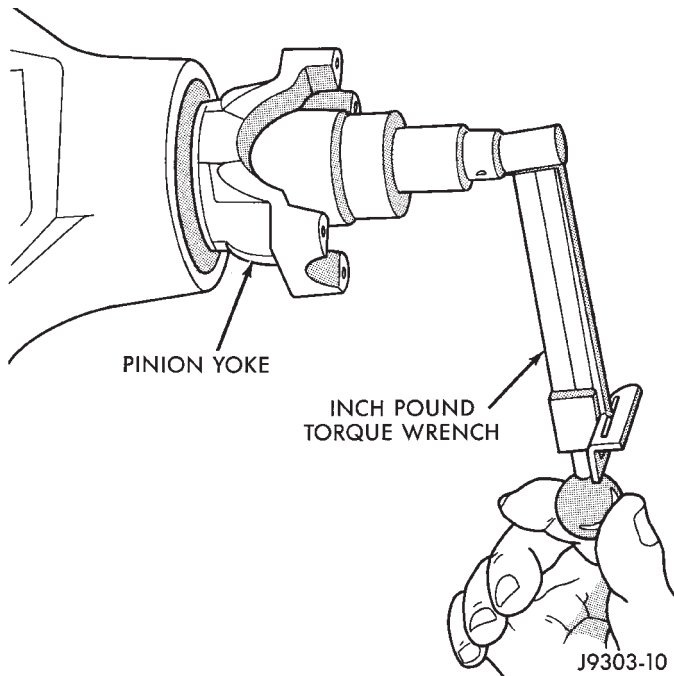


Fig. 12 Check Pinion Rotation Torque

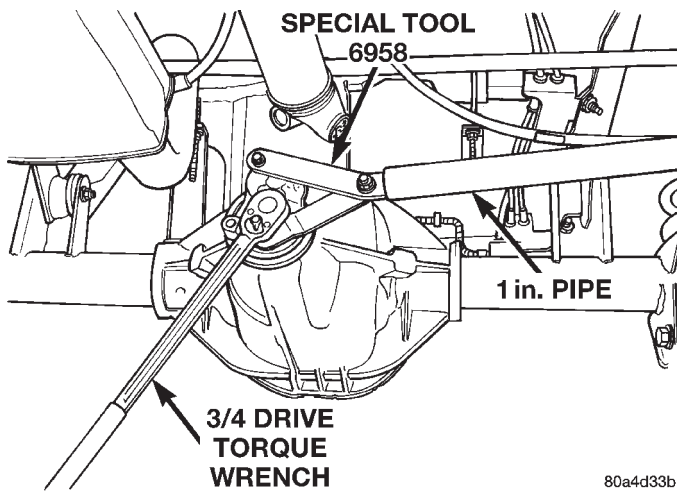


Fig. 13 Tightening Pinion Shaft Nut

- (9) Install the brake rotors and calipers. Refer to Group 5, Brakes, for proper procedures.
- (10) Install wheel and tire assemblies.
- (11) Lower the vehicle.

COLLAPSIBLE SPACER

REMOVAL W/PINION INSTALLED

- (1) Raise and support the vehicle.
- (2) Remove wheel and tire assemblies.
- (3) Remove rear brake rotors and calipers. Refer to Group 5, Brakes, for proper procedures.
- (4) Mark the propeller shaft and pinion yoke for installation reference.
- (5) Remove the propeller shaft from the yoke.
- (6) Rotate the pinion gear three or four times.

(7) Measure the amount of torque necessary to rotate the pinion gear with a (in. lbs.) dial-type torque wrench. Record the torque reading for installation reference.

(8) Using a short piece of pipe and Holder 6958 to hold the pinion yoke, remove the pinion nut and washer (Fig. 14).

(9) Use Remover C-452 and Wrench C-3281 to remove the pinion yoke (Fig. 15).

(10) Use Remover 7794-A and slide hammer to remove the pinion shaft seal (Fig. 16).

(11) Remove the front pinion bearing using a pair of suitable pick tools to pull the bearing straight off the pinion gear shaft. It may be necessary to lightly tap the end of the pinion gear with a rawhide or rubber mallet if the bearing becomes bound on the pinion shaft.

(12) Remove the collapsible spacer.

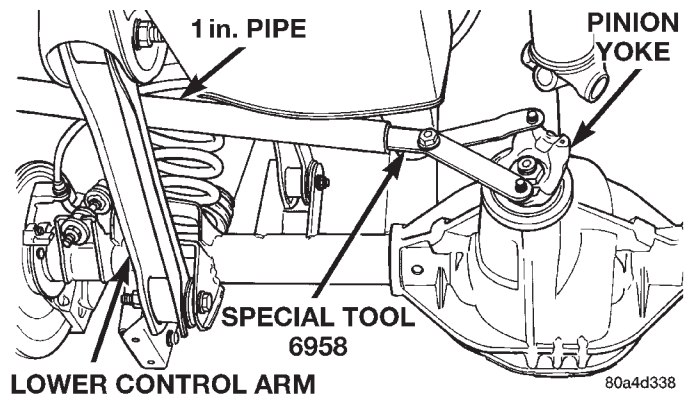


Fig. 14 Pinion Yoke Holder

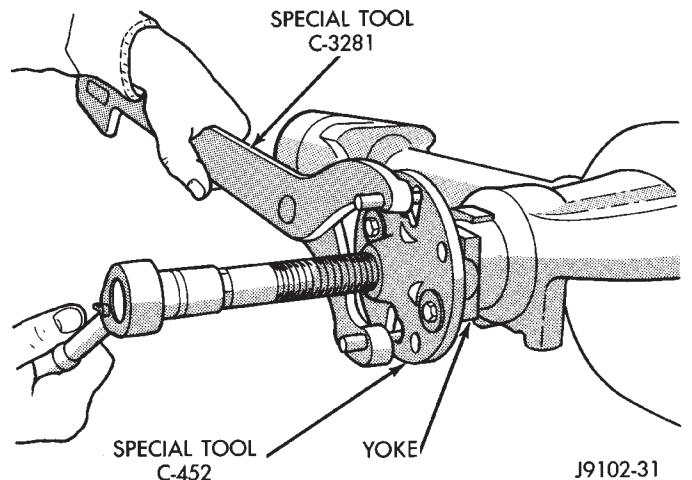
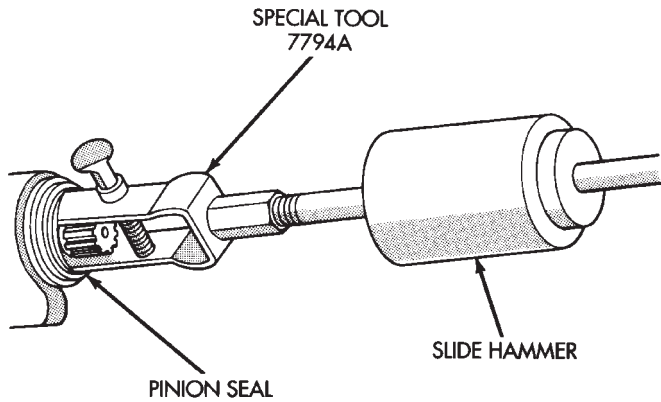


Fig. 15 Pinion Yoke Removal

REMOVAL W/PINION REMOVED

- (1) Raise and support the vehicle.
- (2) Remove wheel and tire assemblies.
- (3) Remove rear brake rotors and calipers. Refer to Group 5, Brakes, for proper procedures.

REMOVAL AND INSTALLATION (Continued)



J9402-59X

Fig. 16 Seal Removal

(4) Mark the propeller shaft and pinion yoke for installation reference.

(5) Remove the propeller shaft from the yoke.

(6) Rotate the pinion gear three or four times.

(7) Measure the amount of torque necessary to rotate the pinion gear with a (in. lbs.) dial-type torque wrench. Record the torque reading for installation reference.

(8) Remove differential assembly from axle housing.

(9) Using Holder 6958 to hold yoke and a short length of 1 in. pipe, remove the pinion yoke nut and washer (Fig. 14).

(10) Using Remover C-452 and Wrench C-3281, remove the pinion yoke from pinion shaft (Fig. 15).

(11) Remove the pinion gear from housing (Fig. 17). Catch the pinion with your hand to prevent it from falling and being damaged.

(12) Remove collapsible spacer from pinion shaft.

INSTALLATION

(1) Install a new collapsible preload spacer on pinion shaft (Fig. 18).

(2) If pinion gear was removed, install pinion gear in housing.

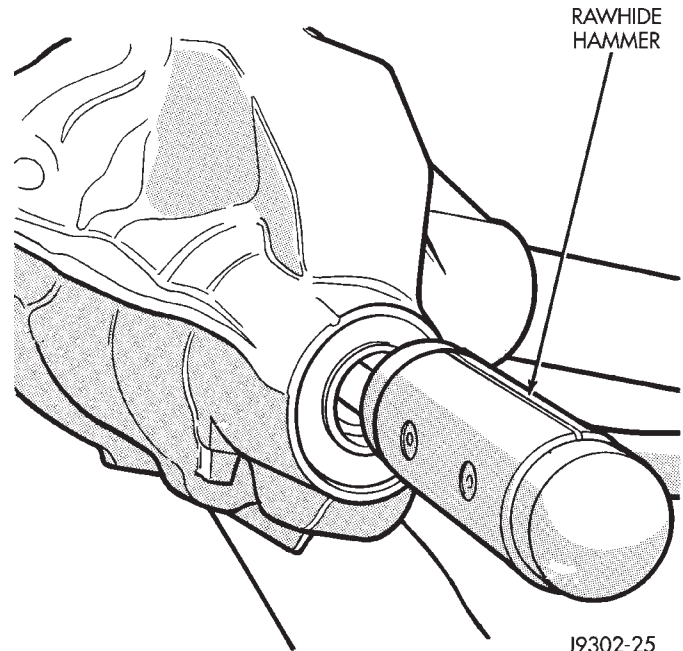
(3) Install pinion front bearing, if necessary.

(4) Apply a light coating of gear lubricant on the lip of pinion seal. Install seal with Installer C-3972-A and Handle C-4171 (Fig. 19).

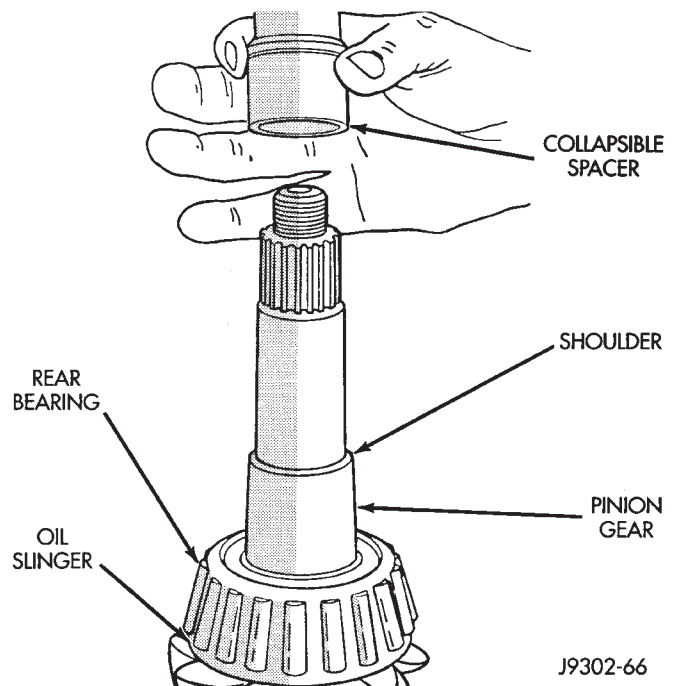
(5) Install yoke with Screw 8112, Cup 8109, and Holder 6958 (Fig. 20).

(6) If the original pinion bearings are being used, install differential assembly and axle shafts, if necessary.

NOTE: If new pinion bearings were installed, do not install the differential assembly and axle shafts until after the pinion bearing preload and rotating torque are set.



J9302-25

Fig. 17 Remove Pinion Gear

J9302-66

Fig. 18 Collapsible Preload Spacer

(7) Install the yoke washer and a new nut on the pinion gear. Tighten the pinion nut until there is zero bearing end-play.

(8) Tighten the nut to 271 N·m (200 ft. lbs.).

REMOVAL AND INSTALLATION (Continued)

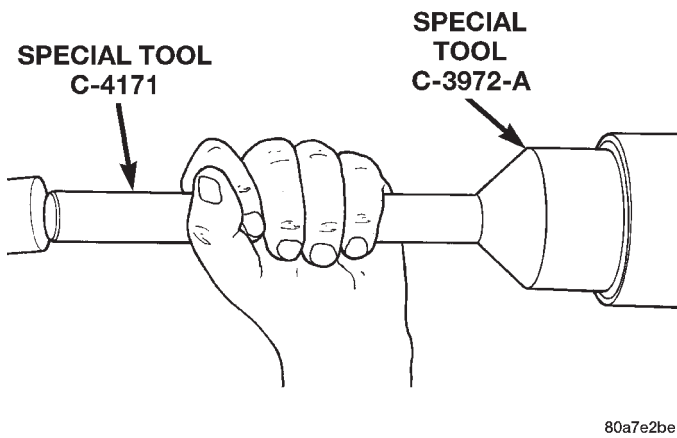


Fig. 19 Pinion Seal Installation

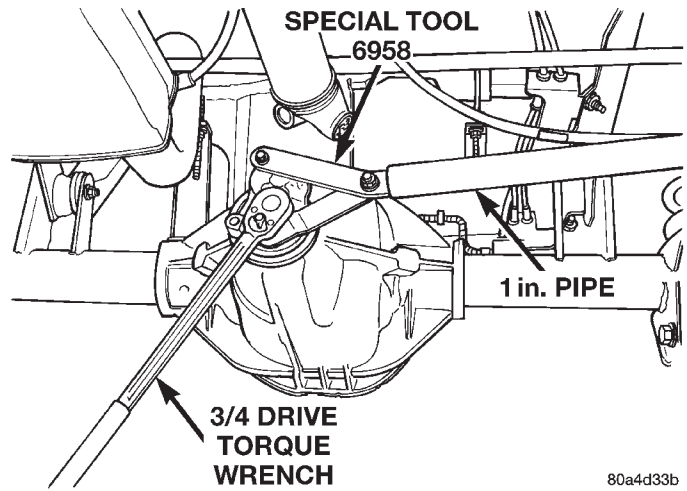


Fig. 21 Tightening Pinion Nut

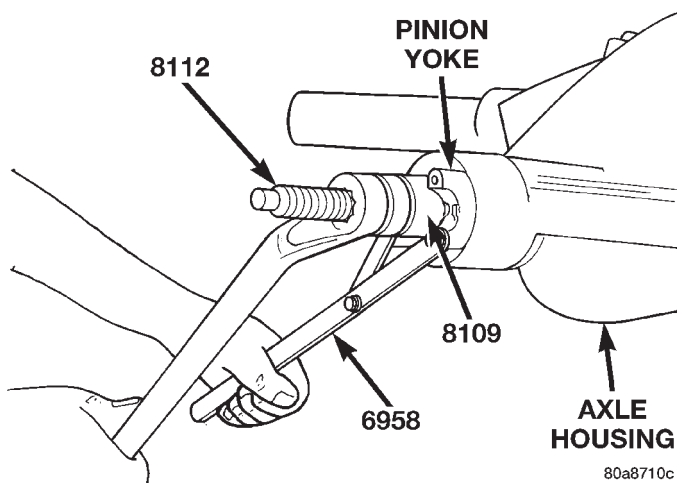


Fig. 20 Pinion Yoke Installation

CAUTION: Never loosen pinion gear nut to decrease pinion gear bearing rotating torque and never exceed specified preload torque. If preload torque or rotating torque is exceeded a new collapsible spacer must be installed. The torque sequence will then have to be repeated.

(9) Using yoke holder 6958, a short length of 1 in. pipe, and a torque wrench set at 474 N·m (350 ft. lbs.), crush collapsible spacer until bearing end play is taken up (Fig. 21).

NOTE: If more than 474 N·m (350 ft. lbs.) of torque is necessary to remove the bearing end play, the collapsible spacer is defective and must be replaced.

(10) Slowly tighten the nut in 6.8 N·m (5 ft. lbs.) increments until the rotating torque is achieved. Measure the rotating torque frequently to avoid over crushing the collapsible spacer (Fig. 22).

(11) Check rotating torque with an inch pound torque wrench (Fig. 22). The torque necessary to rotate the pinion gear should be:

- Original Bearings — The reading recorded during removal, plus an additional 0.56 N·m (5 in. lbs.).
- New Bearings — 2 to 5 N·m (15 to 35 in. lbs.).

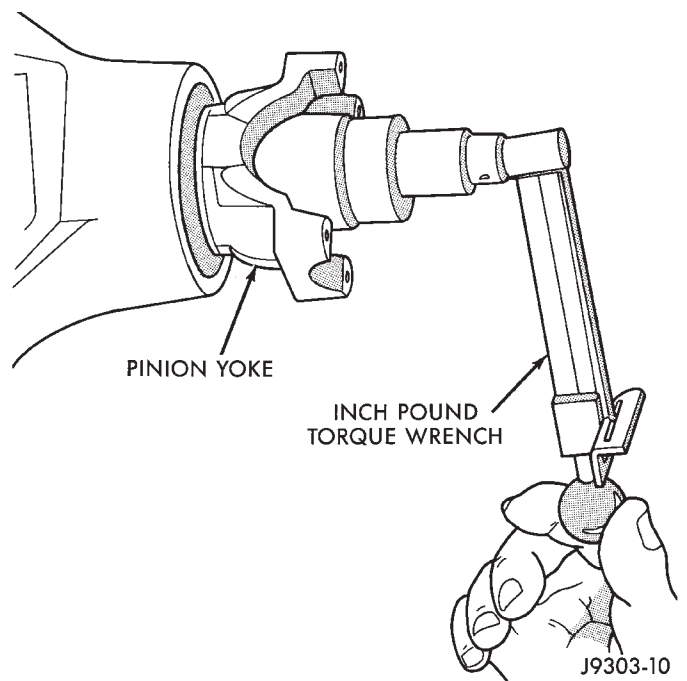


Fig. 22 Check Pinion Gear Rotation Torque

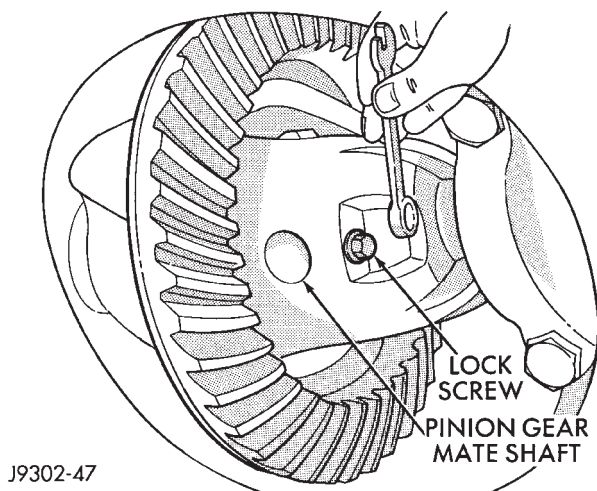
- (12) Install differential assembly and axle shafts, if necessary.
- (13) Align marks made previously on yoke and propeller shaft and install propeller shaft.
- (14) Install rear brake rotors and calipers. Refer to Group 5, Brakes, for proper procedures.
- (15) Add gear lubricant, if necessary. Refer to Lubricant Specifications of this section for lubricant requirements.

REMOVAL AND INSTALLATION (Continued)

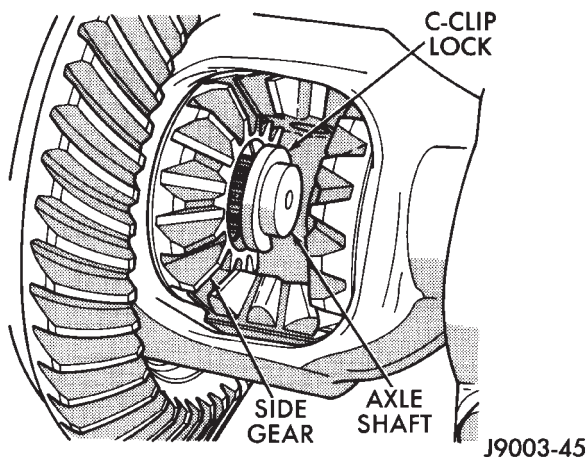
- (16) Install wheel and tire assemblies.
- (17) Lower vehicle.

AXLE SHAFT**REMOVAL**

- (1) Raise and support vehicle. Ensure that the transmission is in neutral.
- (2) Remove wheel and tire assembly.
- (3) Remove brake caliper and rotor. Refer to Group 5, Brakes, for proper procedure.
- (4) Clean all foreign material from housing cover area.
- (5) Loosen housing cover bolts. Drain lubricant from the housing and axle shaft tubes. Remove housing cover.
- (6) Rotate differential case so that pinion mate gear shaft lock screw is accessible. Remove lock screw and pinion mate gear shaft from differential case (Fig. 23).

**Fig. 23 Mate Shaft Lock Screw**

- (7) Push axle shaft inward and remove axle shaft C-clip lock from the axle shaft (Fig. 24).

**Fig. 24 Axle Shaft C-Clip Lock**

(8) Remove axle shaft. Use care to prevent damage to axle shaft bearing and seal, which will remain in axle shaft tube. Also, exercise care not to damage the wheel speed sensor on vehicles equipped with ABS brakes.

- (9) Inspect axle shaft seal for leakage or damage.

(10) Inspect roller bearing contact surface on axle shaft for signs of brinelling, galling and pitting. If any of these conditions exist, the axle shaft and/or bearing and seal must be replaced.

INSTALLATION

(1) Lubricate bearing bore and seal lip with gear lubricant. Insert axle shaft through seal, bearing, and engage it into side gear splines.

NOTE: Use care to prevent shaft splines from damaging axle shaft seal lip. Also, exercise care not to damage the wheel speed sensor on vehicles equipped with ABS brakes

(2) Insert C-clip lock in end of axle shaft. Push axle shaft outward to seat C-clip lock in side gear.

(3) Insert pinion mate shaft into differential case and through thrust washers and pinion gears.

(4) Align hole in shaft with hole in the differential case and install lock screw with Loctite® on the threads. Tighten lock screw to 19 N·m (14 ft. lbs.) torque.

(5) Install cover and add fluid. Refer to Lubricant Change procedure in this section for procedure and lubricant requirements.

(6) Install brake caliper and rotor. Refer to Group 5, Brakes, for proper procedures.

- (7) Install wheel and tire.
- (8) Lower vehicle.

AXLE SHAFT SEAL AND BEARING**REMOVAL**

- (1) Remove the axle shaft.
- (2) Remove the axle shaft seal from the end of the axle shaft tube with a small pry bar.

NOTE: The seal and bearing can be removed at the same time with the bearing removal tool.

(3) Remove the axle shaft bearing from the axle tube with Bearing Removal Tool Set 6310 using Adapter Foot 6310-5 (Fig. 25).

(4) Inspect the axle shaft tube bore for roughness and burrs. Remove as necessary.

INSTALLATION

Do not install the original axle shaft seal. Always install a new seal.

- (1) Wipe the axle shaft tube bore clean.

REMOVAL AND INSTALLATION (Continued)

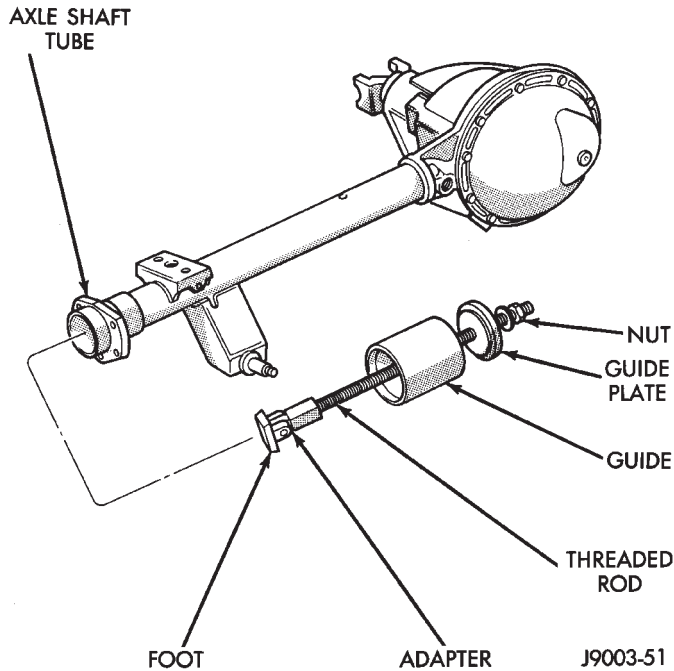


Fig. 25 Axle Shaft Bearing Removal

- (2) Install axle shaft bearing with Installer 6436 and Handle C-4171. Ensure that the part number on the bearing is against the installer.
- (3) Install the new axle shaft seal with Installer 6437 and Handle C-4171 (Fig. 26).

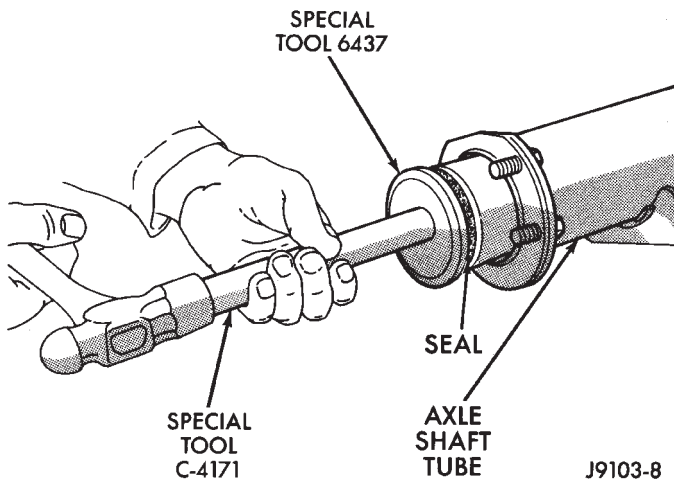


Fig. 26 Axle Shaft Seal Installation

- (4) Install the axle shaft.

DIFFERENTIAL

REMOVAL

- (1) Raise and support vehicle.
- (2) Remove the lubricant fill hole plug from the differential housing cover.
- (3) Remove the differential housing cover and allow fluid to drain.

- (4) Remove axle shafts.
- (5) Note the installation reference letters stamped on the bearing caps and housing machined sealing surface (Fig. 27).

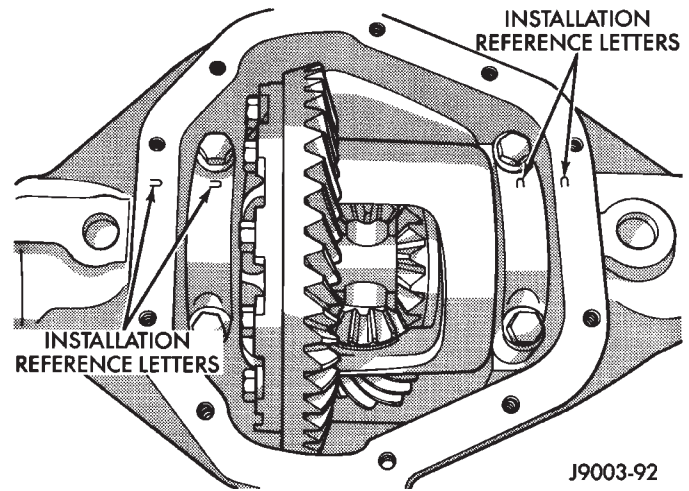


Fig. 27 Bearing Cap Identification

- (6) Loosen the differential bearing cap bolts.
- (7) Position Spreader W-129-B, utilizing some items from Adapter set 6987, with the tool dowel pins seated in the locating holes (Fig. 28). Install the hold-down clamps and tighten the tool turnbuckle finger-tight.

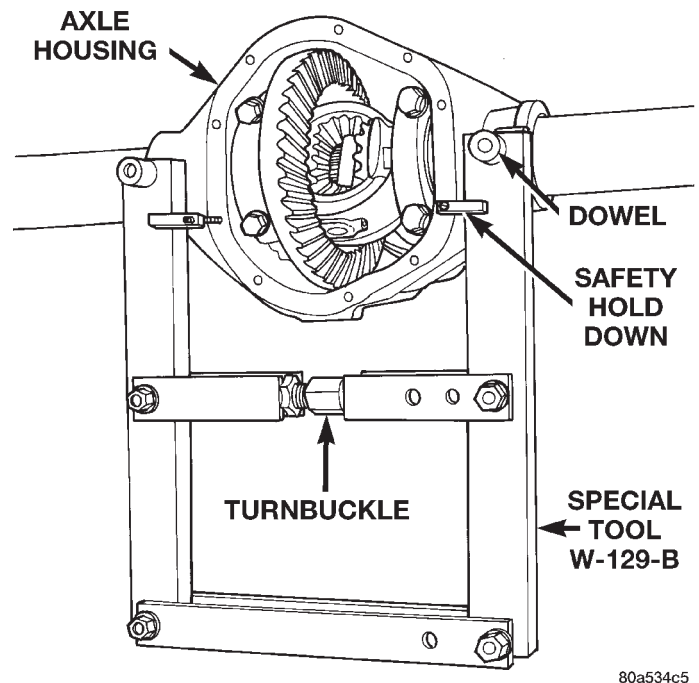


Fig. 28 Install Axle Housing Spreader

- (8) Install a Pilot Stud C-3288-B at the left side of the differential housing. Attach Dial Indicator C-3339 to pilot stud. Load the indicator plunger against the opposite side of the housing (Fig. 29) and zero the indicator.

REMOVAL AND INSTALLATION (Continued)

CAUTION: Do not spread over 0.38 mm (0.015 in). If the housing is over-spread, it could be distorted or damaged.

(9) Spread the housing enough to remove the differential case from the housing. Measure the distance with the dial indicator (Fig. 30).

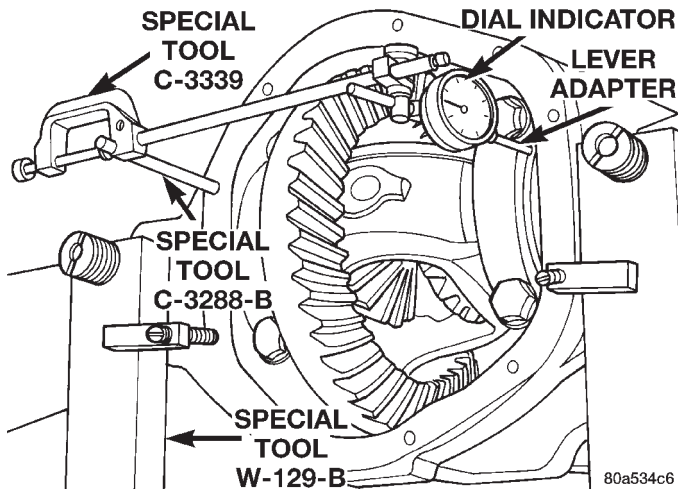


Fig. 29 Install Dial Indicator

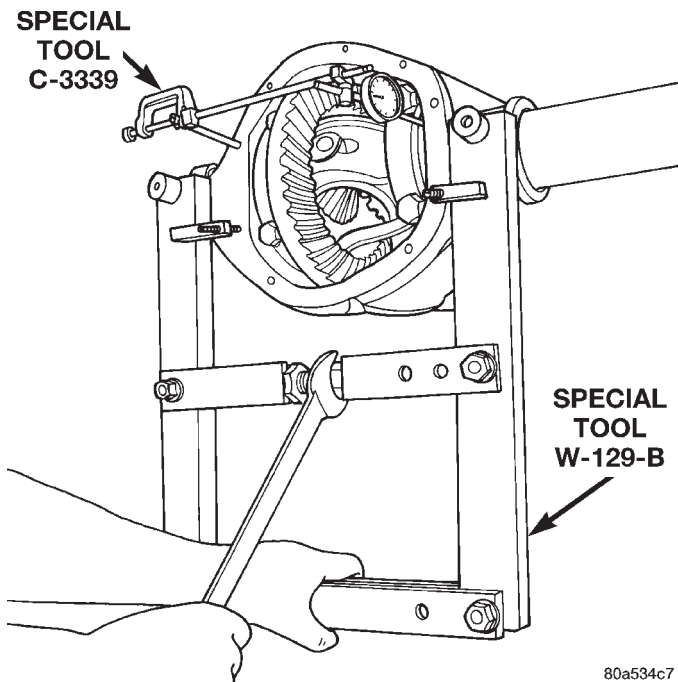


Fig. 30 Spread Axle Housing

- (10) Remove the dial indicator.
- (11) While holding the differential case in position, remove the differential bearing cap bolts and caps.
- (12) Remove the differential from the housing. Ensure that the differential bearing cups remain in position on the differential bearings (Fig. 31).

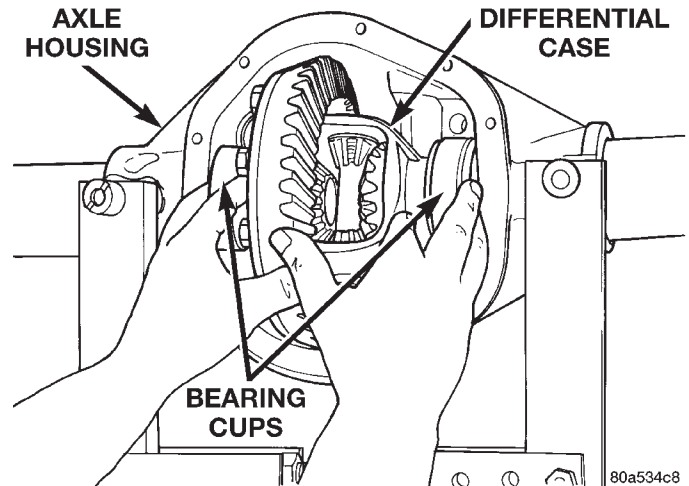


Fig. 31 Differential Case Removal

(13) Mark or tag the differential bearing cups to indicate which side of the differential they were removed from.

(14) Retrieve differential case preload shims from axle housing. Mark or tag the differential case preload shims to indicate which side of the differential they were removed from.

(15) Remove spreader from housing.

INSTALLATION

If replacement differential bearings or differential case are being installed, differential side bearing shim requirements may change. Refer to the Differential Bearing Preload and Gear Backlash procedures in this section to determine the proper shim selection.

(1) Position Spreader W-129-B, utilizing some items from Adapter set 6987, with the tool dowel pins seated in the locating holes (Fig. 32). Install the hold-down clamps and tighten the tool turnbuckle finger-tight.

(2) Install a Pilot Stud C-3288-B at the left side of the differential housing. Attach Dial Indicator C-3339 to pilot stud. Load the indicator plunger against the opposite side of the housing (Fig. 29) and zero the indicator.

CAUTION: Do not spread over 0.38 mm (0.015 in). If the housing is over-spread, it could be distorted or damaged.

(3) Spread the housing enough to install the case in the housing. Measure the distance with the dial indicator (Fig. 30).

(4) Remove the dial indicator.

(5) Install differential case in the housing. Ensure that the differential bearing cups remain in position on the differential bearings and that the preload shims remain between the face of the bearing cup

REMOVAL AND INSTALLATION (Continued)

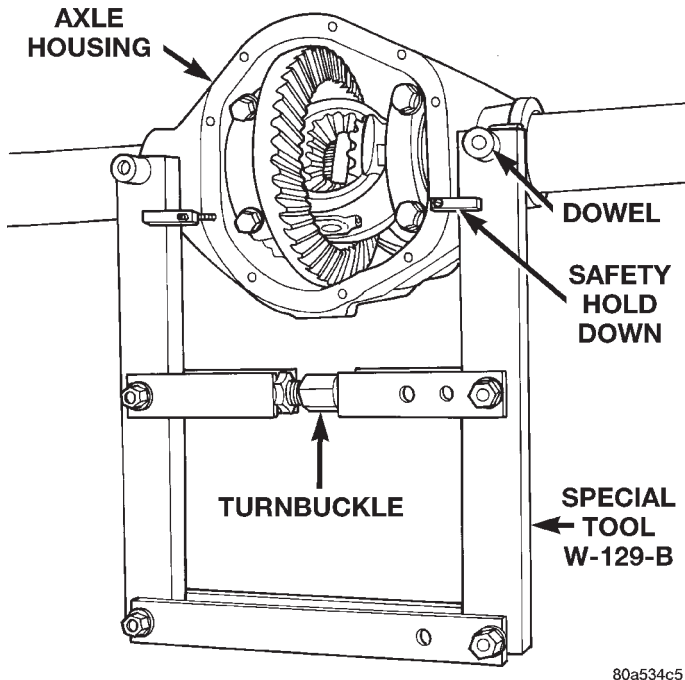


Fig. 32 Install Axle Housing Spreader

and the housing. Tap the differential case to ensure the bearings cups and shims are fully seated in the housing.

(6) Install the bearing caps at their original locations (Fig. 33).

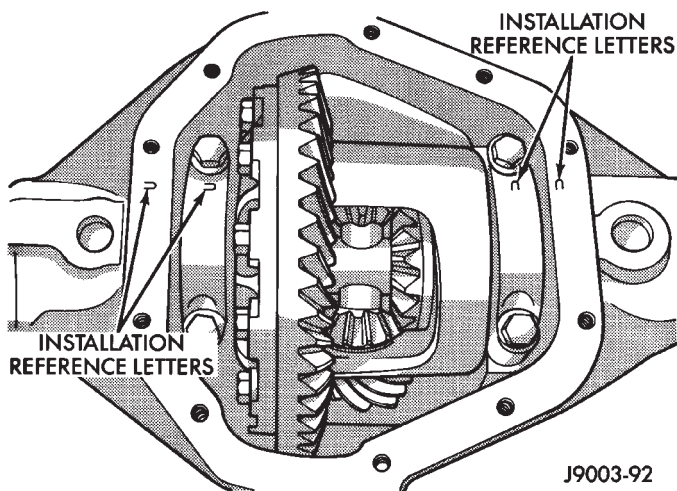


Fig. 33 Differential Bearing Cap Reference Letters

- (7) Loosely install differential bearing cap bolts.
- (8) Remove axle housing spreader.
- (9) Tighten the bearing cap bolts to 77 N·m (57 ft. lbs.) torque.
- (10) Install the axle shafts.

DIFFERENTIAL SIDE BEARINGS

REMOVAL

- (1) Remove differential from axle housing.

- (2) Remove the bearings from the differential case with Puller/Press C-293-PA, C-293-39 Blocks, and Plug SP-3289 (Fig. 34).

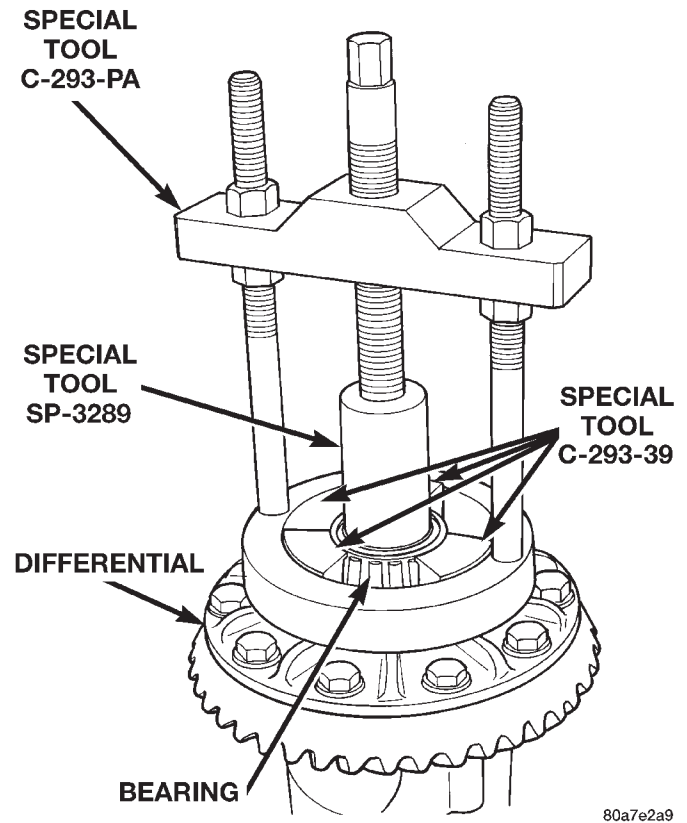


Fig. 34 Differential Bearing Removal

INSTALLATION

- (1) Using tool C-3716-A with handle C-4171, install differential side bearings (Fig. 35).
- (2) Install differential in axle housing.

RING GEAR

The ring and pinion gears are service in a matched set. Do not replace the ring gear without replacing the pinion gear.

REMOVAL

- (1) Remove differential from axle housing.
- (2) Place differential case in a suitable vise with soft metal jaw protectors. (Fig. 36)
- (3) Remove bolts holding ring gear to differential case.
- (4) Using a soft hammer, drive ring gear from differential case (Fig. 36).

INSTALLATION

CAUTION: Do not reuse the bolts that held the ring gear to the differential case. The bolts can fracture causing extensive damage.

REMOVAL AND INSTALLATION (Continued)

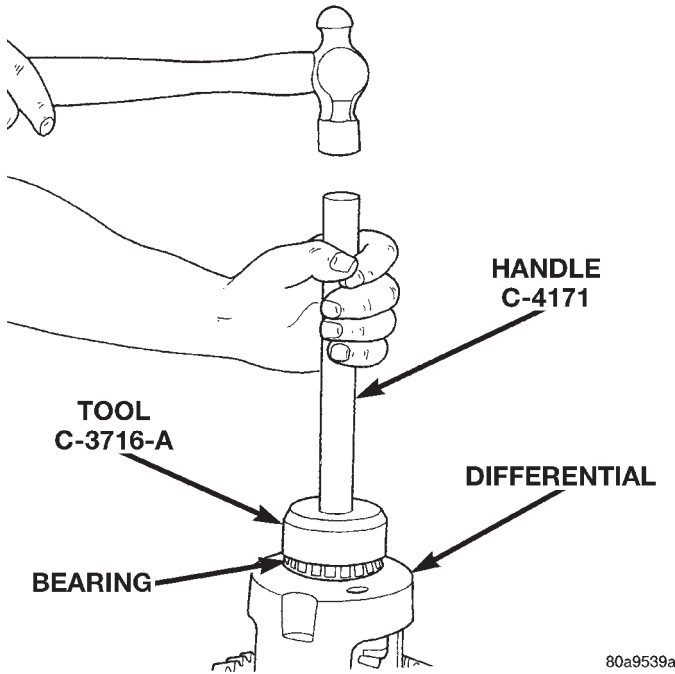


Fig. 35 Install Differential Side Bearings

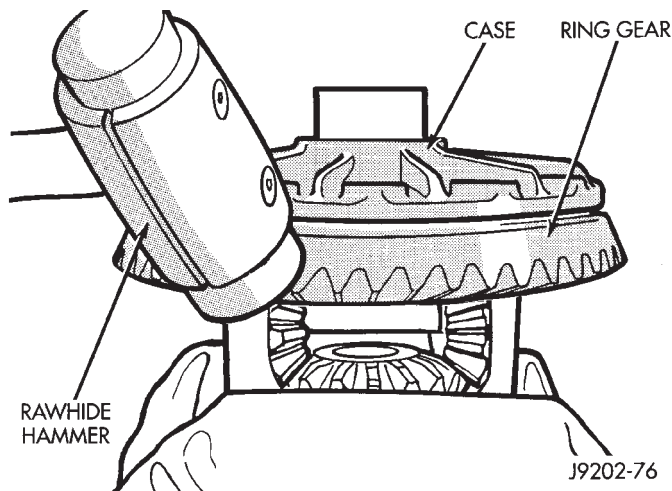


Fig. 36 Ring Gear Removal

- (1) Invert the differential case and start two ring gear bolts. This will provide case-to-ring gear bolt hole alignment.
- (2) Invert the differential case in the vise.
- (3) Install new ring gear bolts and alternately tighten to 95–122 N·m (70–90 ft. lbs.) torque (Fig. 37).
- (4) Install differential in axle housing and verify gear mesh and contact pattern.

PINION GEAR

The ring and pinion gears are serviced in a matched set. Do not replace the pinion gear without replacing the ring gear.

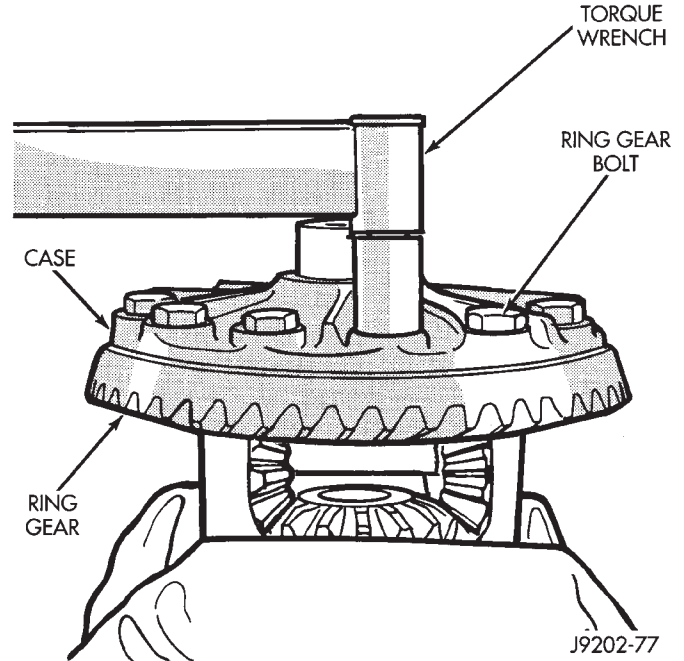


Fig. 37 Ring Gear Bolt Installation

REMOVAL

- (1) Remove differential from the axle housing.
- (2) Mark pinion yoke and propeller shaft for installation alignment.
- (3) Disconnect propeller shaft from pinion yoke. Using suitable wire, tie propeller shaft to underbody.
- (4) Using Holder 6958 to hold yoke and a short length of 1 in. pipe, remove the pinion yoke nut and washer (Fig. 38).
- (5) Using Remover C-452 and Wrench C-3281, remove the pinion yoke from pinion shaft (Fig. 39).

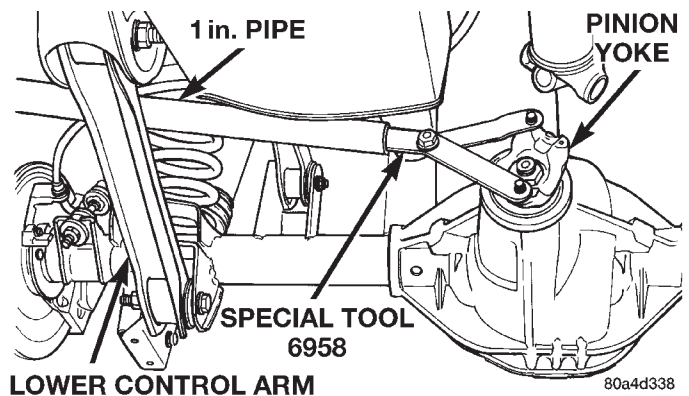


Fig. 38 Pinion Yoke Holder

REMOVAL AND INSTALLATION (Continued)

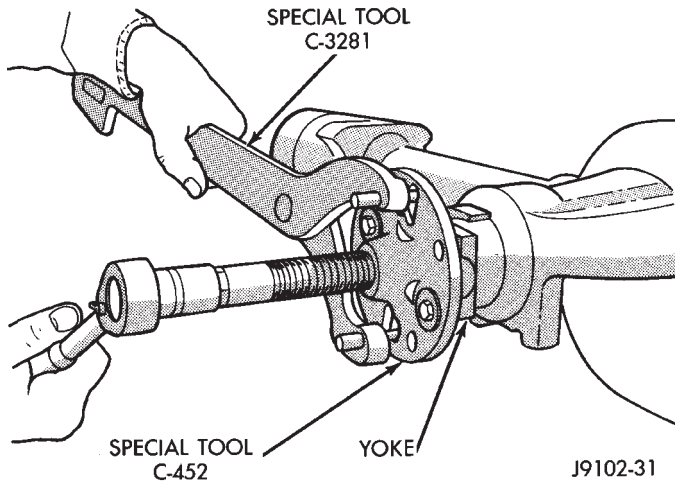


Fig. 39 Pinion Yoke Removal

(6) Remove the pinion gear from housing (Fig. 40). Catch the pinion with your hand to prevent it from falling and being damaged.

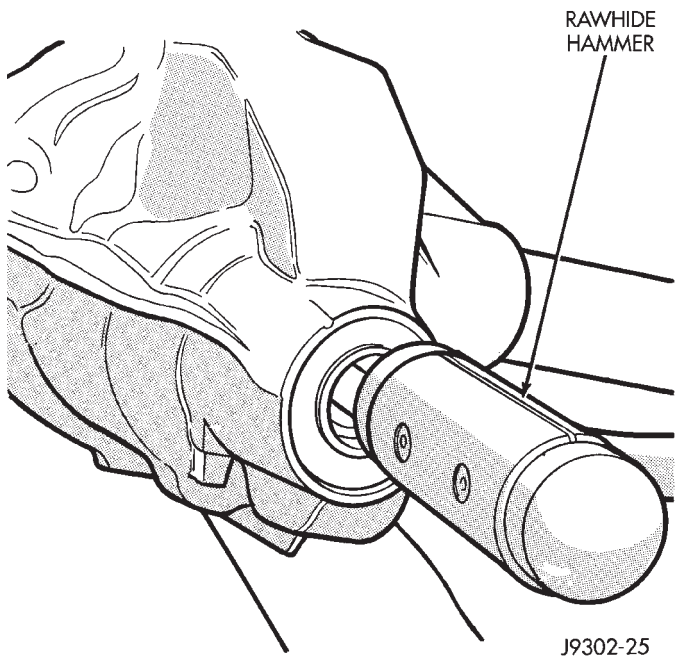


Fig. 40 Remove Pinion Gear

(7) Use Remover 7794-A and slide hammer to remove the pinion shaft seal (Fig. 41).

(8) Remove oil slinger, if equipped, and front pinion bearing.

(9) Remove the front pinion bearing cup with Remover C-4345 and Handle C-4171 (Fig. 42).

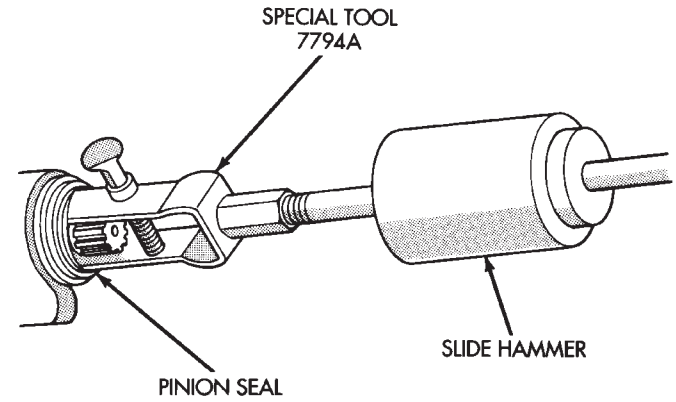


Fig. 41 Seal Removal

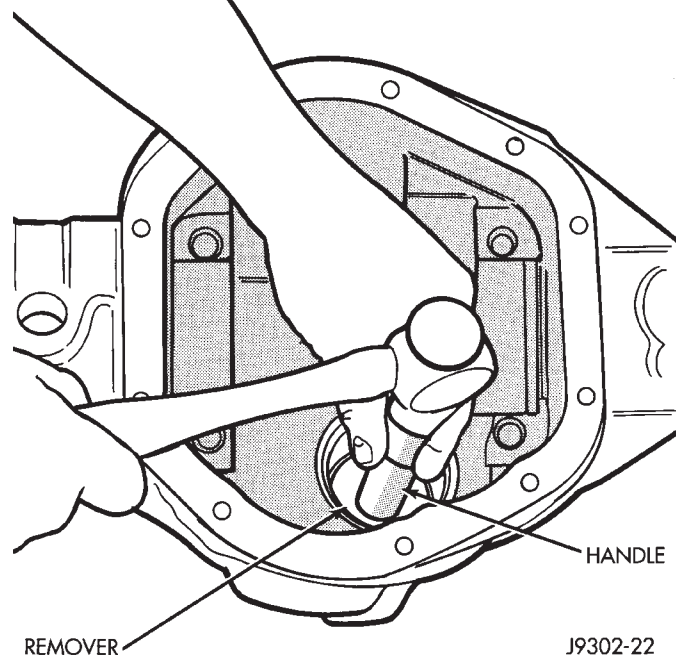


Fig. 42 Front Bearing Cup Removal

REMOVAL AND INSTALLATION (Continued)

(10) Remove the rear bearing cup from housing (Fig. 43). Use Remover D-149 and Handle C-4171.

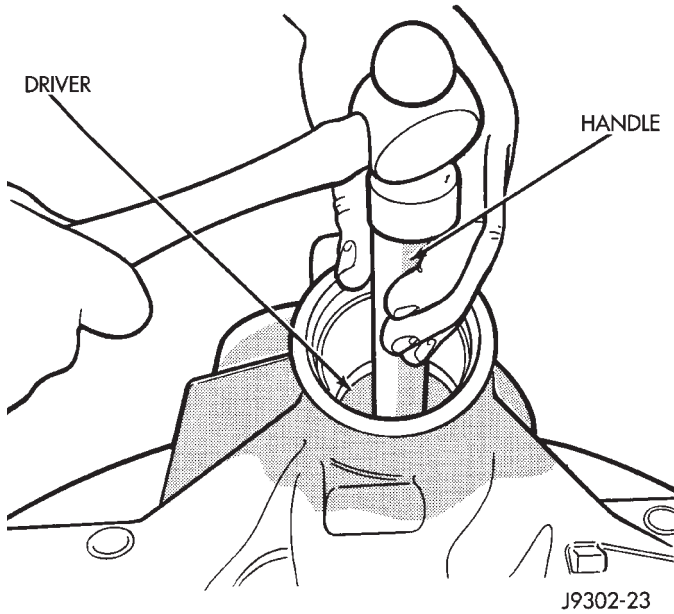


Fig. 43 Rear Bearing Cup Removal

(11) Remove the collapsible preload spacer (Fig. 44).

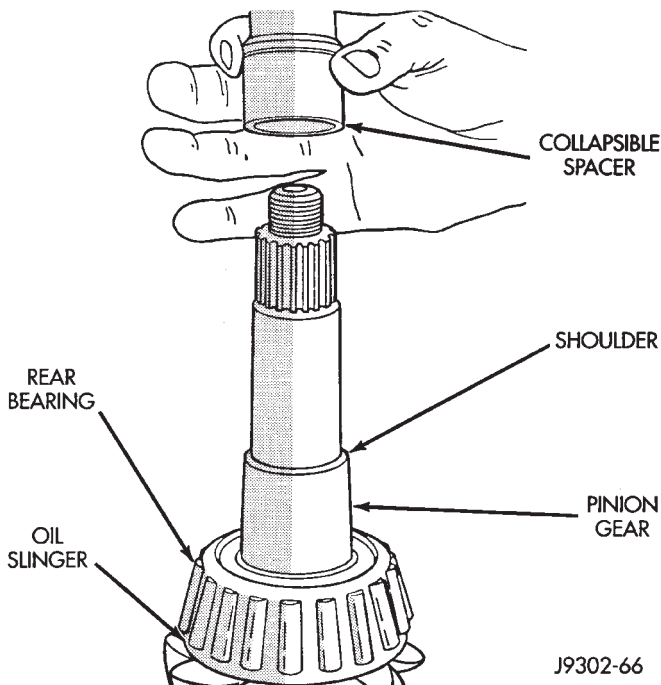


Fig. 44 Collapsible Spacer

(12) Remove the rear bearing from the pinion with Puller/Press C-293-PA and Adapters C-293-40 (Fig. 45).

Place 4 adapter blocks so they do not damage the bearing cage.

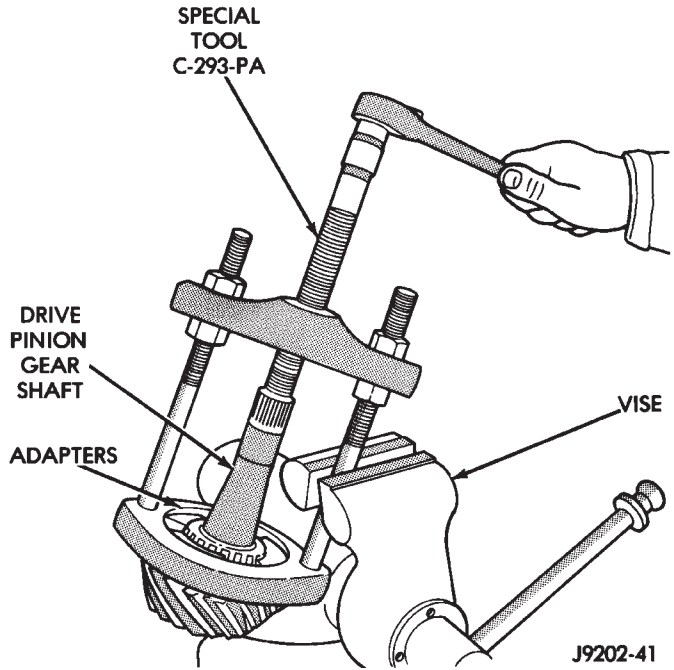


Fig. 45 Rear Bearing Removal

(13) Remove the depth shims from the pinion gear shaft. Record the thickness of the depth shims.

INSTALLATION

(1) Apply Mopar® Door Ease, or equivalent, stick lubricant to outside surface of bearing cup.

(2) Install the pinion rear bearing cup with Installer D-146 and Driver Handle C-4171 (Fig. 46). Ensure cup is correctly seated.

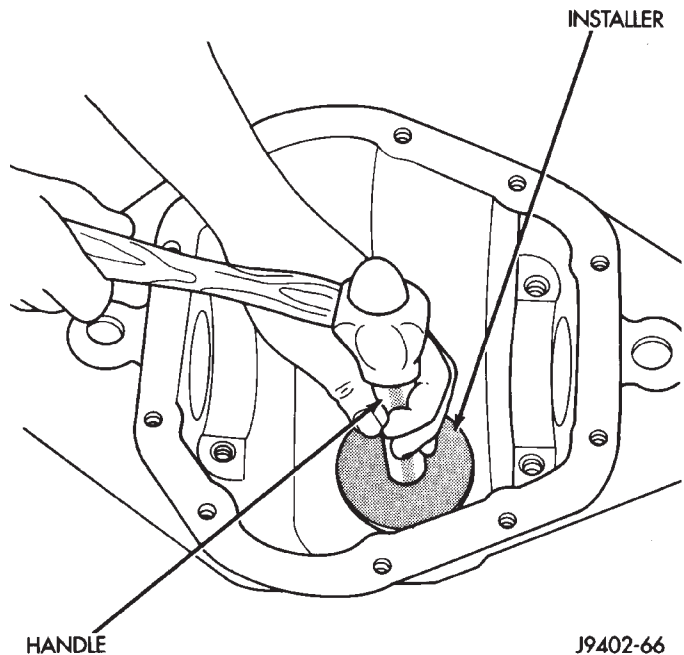


Fig. 46 Pinion Rear Bearing Cup Installation

REMOVAL AND INSTALLATION (Continued)

(3) Apply Mopar® Door Ease, or equivalent, stick lubricant to outside surface of bearing cup.

(4) Install the pinion front bearing cup with Installer D-130 and Handle C-4171 (Fig. 47).

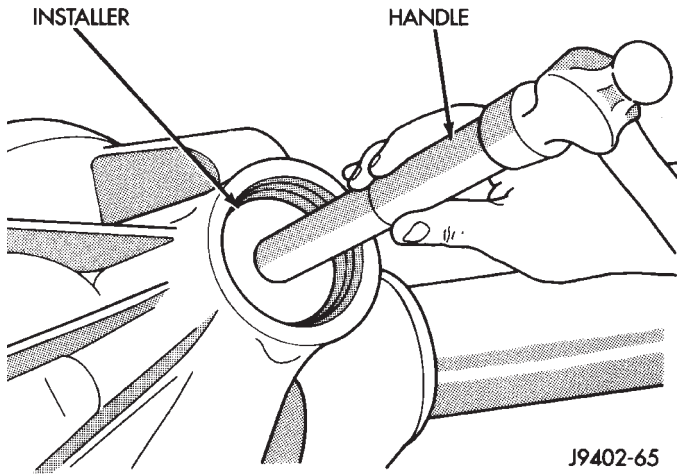


Fig. 47 Pinion Front Bearing Cup Installation

(5) Install pinion front bearing, and oil slinger, if equipped.

(6) Apply a light coating of gear lubricant on the lip of pinion seal. Install seal with Installer C-3972-A and Handle C-4171 (Fig. 48).

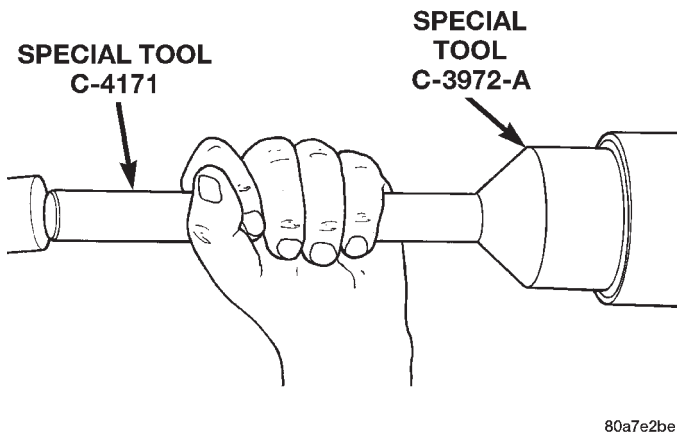


Fig. 48 Pinion Seal Installation

NOTE: Pinion depth shims are placed between the rear pinion bearing cone and pinion gear to achieve proper ring and pinion gear mesh. If the factory installed ring and pinion gears are reused, the pinion depth shim should not require replacement. If required, refer to Pinion Gear Depth to select the proper thickness shim before installing rear pinion bearing.

(7) Place the proper thickness depth shim on the pinion gear.

(8) Install the rear bearing and slinger, if equipped, on the pinion gear with Installer W-262 (Fig. 49).

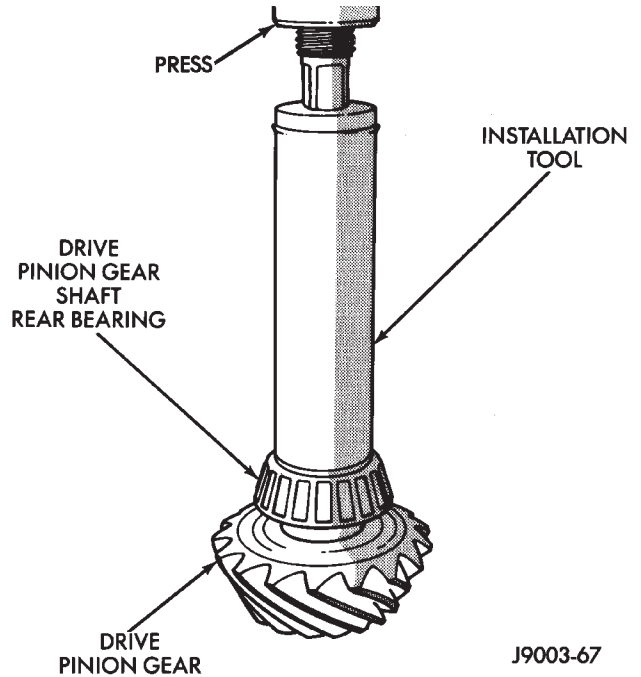


Fig. 49 Shaft Rear Bearing Installation

(9) Install a new collapsible preload spacer on pinion shaft and install pinion gear in housing (Fig. 50).

(10) Install pinion gear in housing.

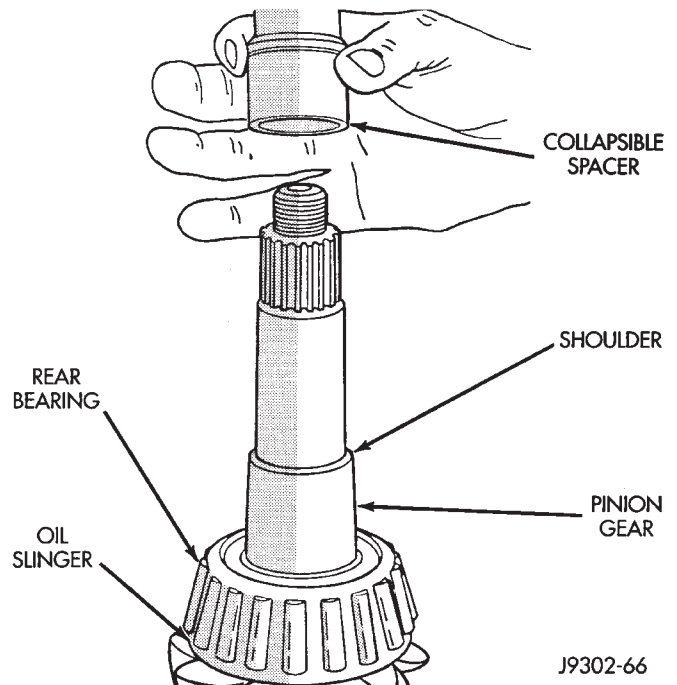


Fig. 50 Collapsible Preload Spacer

REMOVAL AND INSTALLATION (Continued)

(11) Install yoke with Installer Screw 8112, Cup 8109, and holder 6958 (Fig. 51).

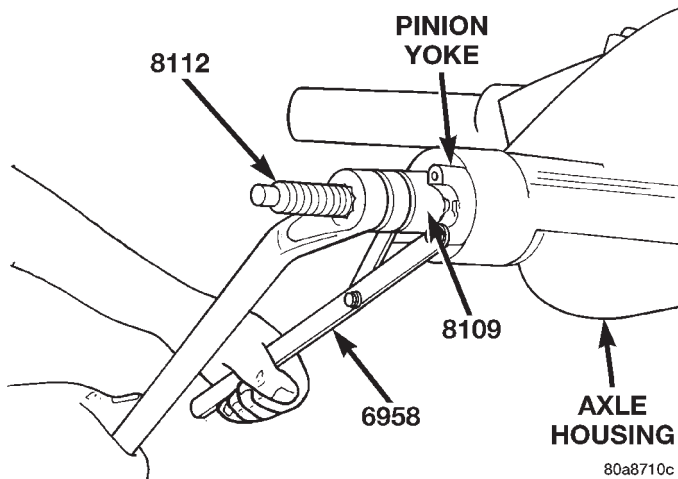


Fig. 51 Pinion Yoke Installation

(12) Install the yoke washer and a new nut on the pinion gear and tighten the pinion nut until there is zero bearing end-play.

(13) Tighten the nut to 271 N·m (200 ft. lbs.).

CAUTION: Never loosen pinion gear nut to decrease pinion gear bearing rotating torque and never exceed specified preload torque. If preload torque or rotating torque is exceeded a new collapsible spacer must be installed. The torque sequence will then have to be repeated.

(14) Using yoke holder 6958, a short length of 1 in. pipe, and a torque wrench set at 474 N·m (350 ft. lbs.), crush collapsible spacer until bearing end play is taken up (Fig. 52).

NOTE: If the spacer requires more than 474 N·m (350 ft. lbs.) torque to crush, the collapsible spacer is defective and must be replaced.

(15) Slowly tighten the nut in 6.8 N·m (5 ft. lbs.) increments until the rotating torque is achieved. Measure the rotating torque frequently to avoid over crushing the collapsible spacer (Fig. 53).

(16) Check bearing rotating torque with an inch pound torque wrench (Fig. 53). The torque necessary to rotate the pinion gear should be:

- Original Bearings — 1 to 3 N·m (10 to 20 in. lbs.).
- New Bearings — 2 to 5 N·m (15 to 35 in. lbs.).

(17) Install differential in housing.

FINAL ASSEMBLY

(1) Scrape the residual sealant from the housing and cover mating surfaces. Clean the mating surfaces with mineral spirits. Apply a bead of Mopar® Silicone

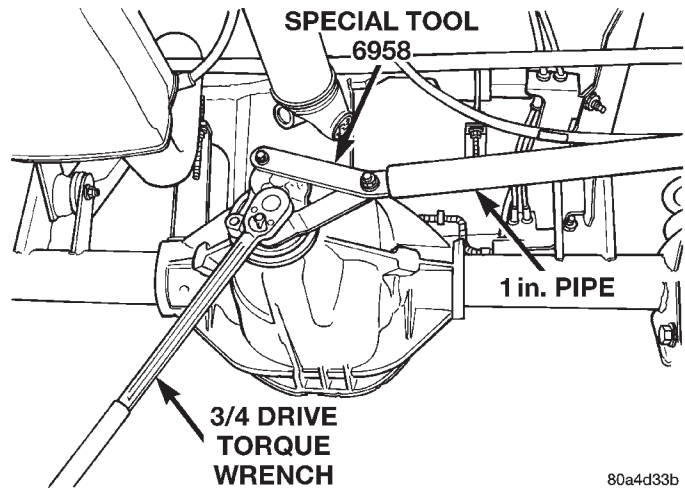


Fig. 52 Tightening Pinion Nut

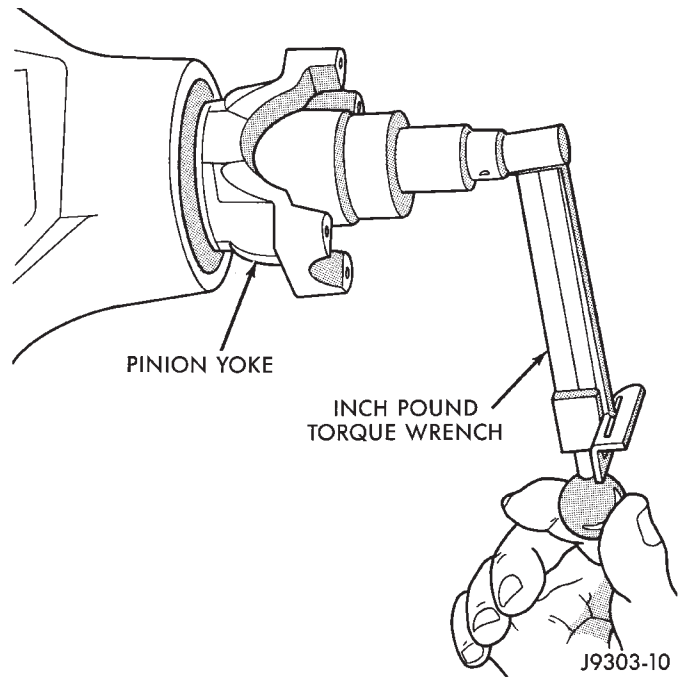


Fig. 53 Check Pinion Gear Rotating Torque

Rubber Sealant, or equivalent, on the housing cover (Fig. 54).

Install the housing cover within 5 minutes after applying the sealant.

(2) Install the cover on the differential with the attaching bolts. Install the identification tag. Tighten the cover bolts to 41 N·m (30 ft. lbs.) torque.

CAUTION: Overfilling the differential can result in lubricant foaming and overheating.

(3) Refill the differential housing with gear lubricant. Refer to the Lubricant Specifications section of this group for the gear lubricant requirements.

(4) Install the fill hole plug.

REMOVAL AND INSTALLATION (Continued)

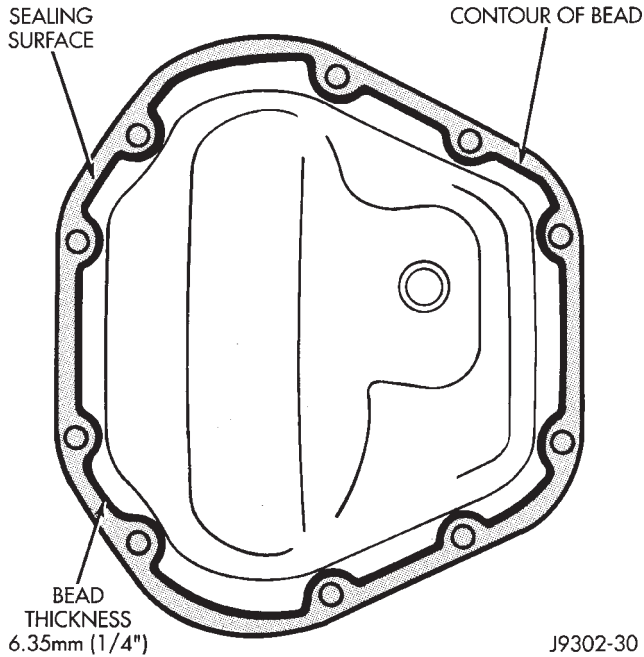


Fig. 54 Typical Housing Cover With Sealant

(4) Remove the differential side gears and thrust washers.

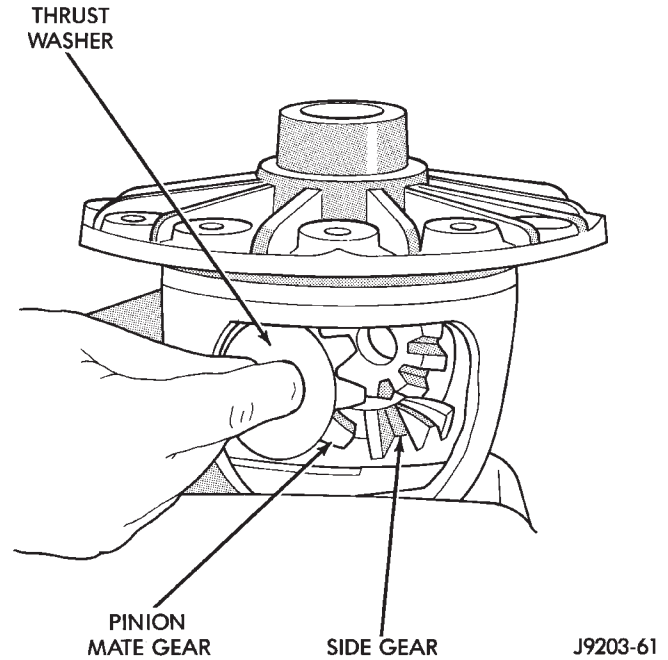


Fig. 56 Pinion Mate Gear Removal

DISASSEMBLY AND ASSEMBLY

STANDARD DIFFERENTIAL

DISASSEMBLY

- (1) Remove pinion gear mate shaft lock screw (Fig. 55).
- (2) Remove pinion gear mate shaft.
- (3) Rotate the differential side gears and remove the pinion mate gears and thrust washers (Fig. 56).

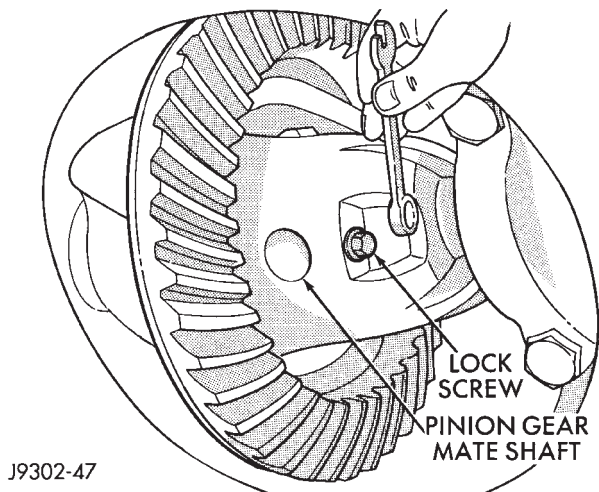


Fig. 55 Pinion Gear Mate Shaft Lock Screw

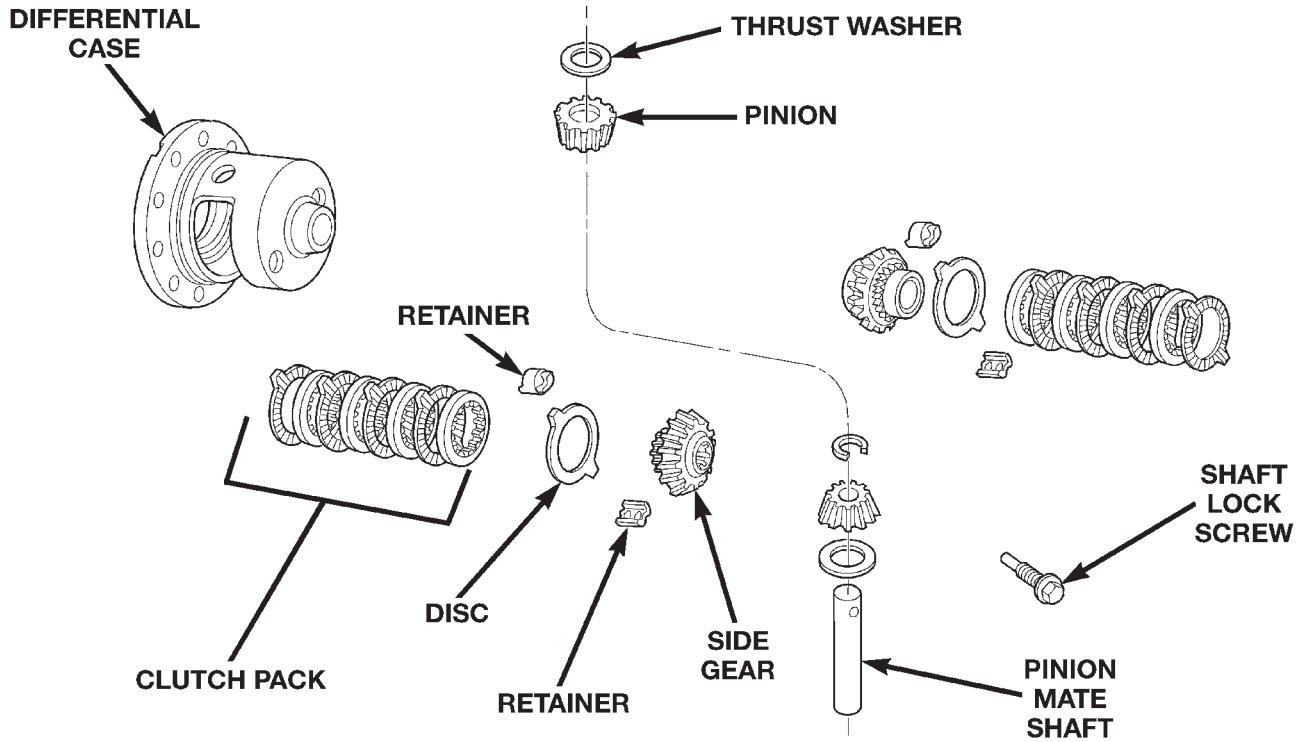
ASSEMBLY

- (1) Install the differential side gears and thrust washers.
- (2) Install the pinion mate gears and thrust washers.
- (3) Install the pinion gear mate shaft.
- (4) Align the hole in the pinion gear mate shaft with the hole in the differential case and install the pinion gear mate shaft lock screw.
- (5) Lubricate all differential components with hypoid gear lubricant.

TRAC-LOK DIFFERENTIAL

The Trac-loc differential components are illustrated in (Fig. 57). Refer to this illustration during repair service.

DISASSEMBLY AND ASSEMBLY (Continued)



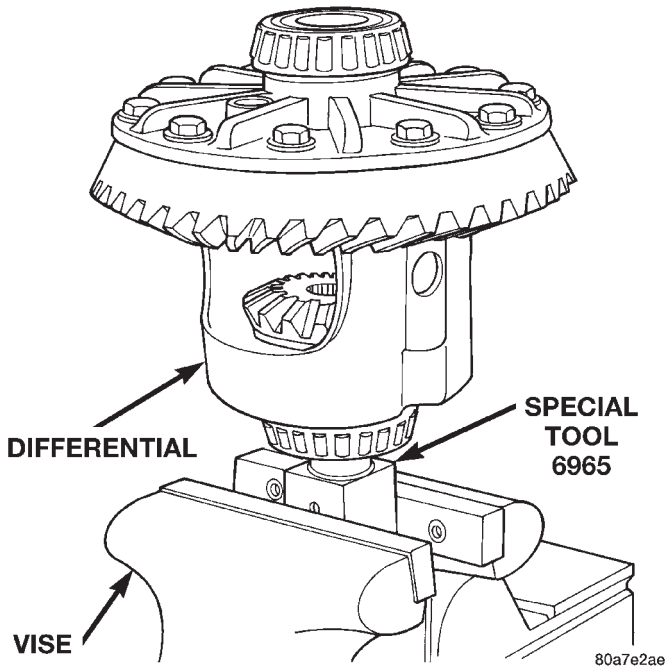
80a77404

Fig. 57 Trac-lok Differential Components

DISASSEMBLY

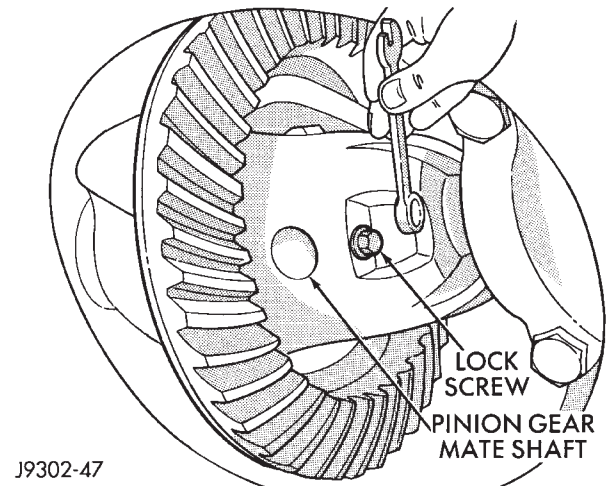
- (1) Clamp Side Gear Holding Tool 6965 in a vise.
- (2) Position the differential case on Side Gear Holding Tool 6965 (Fig. 58).

- (3) Remove ring gear, if necessary. Ring gear removal is necessary only if the ring gear is to be replaced. The Trac-lok differential can be serviced with the ring gear installed.
- (4) Remove the pinion gear mate shaft lock screw (Fig. 59).



80a7e2ae

Fig. 58 Differential Case Holding Tool

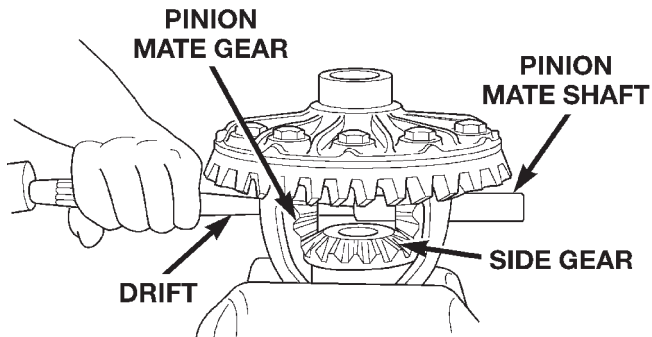


J9302-47

Fig. 59 Mate Shaft Lock Screw

DISASSEMBLY AND ASSEMBLY (Continued)

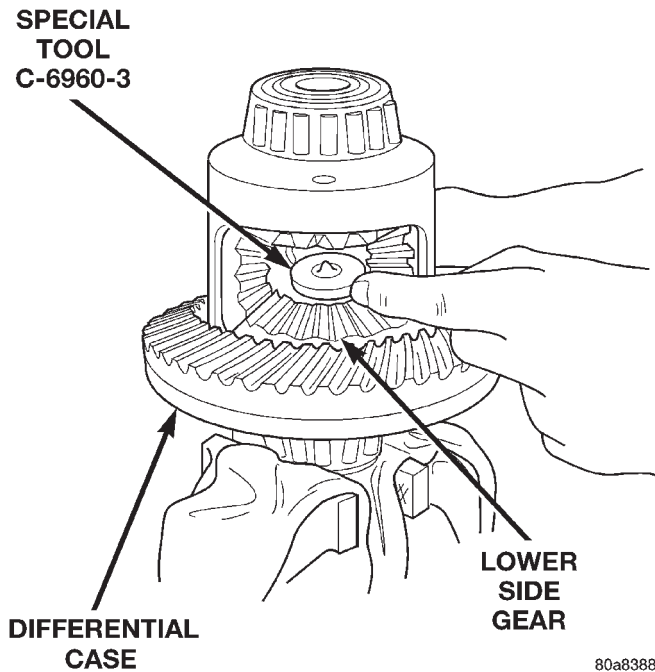
(5) Remove the pinion gear mate shaft. If necessary, use a drift and hammer (Fig. 60).



80a773e1

Fig. 60 Mate Shaft Removal

(6) Install and lubricate Step Plate C-6960-3 (Fig. 61).

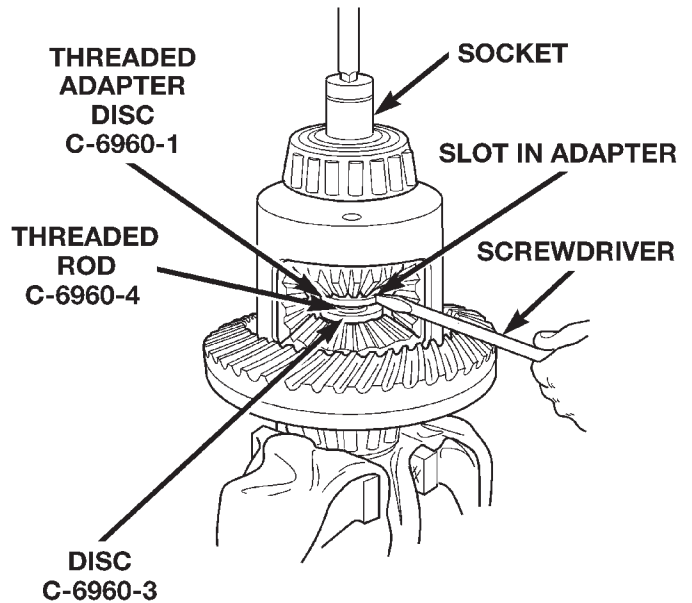


80a83886

Fig. 61 Step Plate Tool Installation

(7) Assemble Threaded Adapter C-6960-1 into top side gear. Thread Forcing Screw C-6960-4 into adapter until it becomes centered in adapter plate.

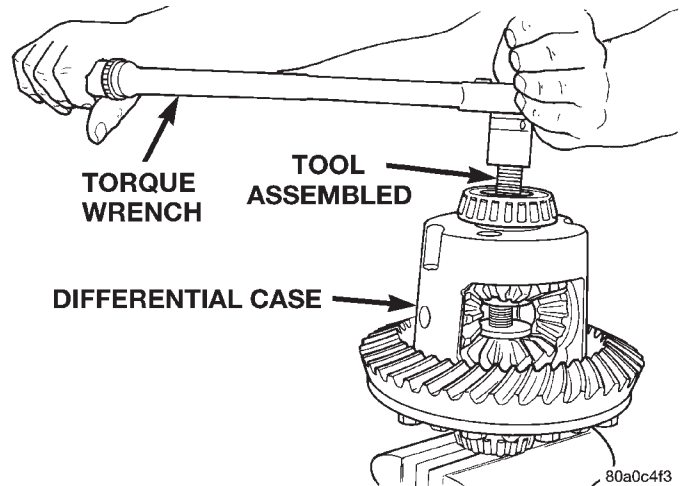
(8) Position a small screw driver in slot of Threaded Adapter C-6960-1 (Fig. 62) to prevent adapter from turning.



80a8387f

Fig. 62 Threaded Adapter Installation

(9) Tighten forcing screw tool 122 N·m (90 ft. lbs.) maximum to compress Belleville springs in clutch packs (Fig. 63).



80a0c4f3

Fig. 63 Tighten Belleville Spring Compressor Tool

DISASSEMBLY AND ASSEMBLY (Continued)

(10) Using an appropriate size feeler gauge, remove thrust washers from behind the pinion gears (Fig. 64).

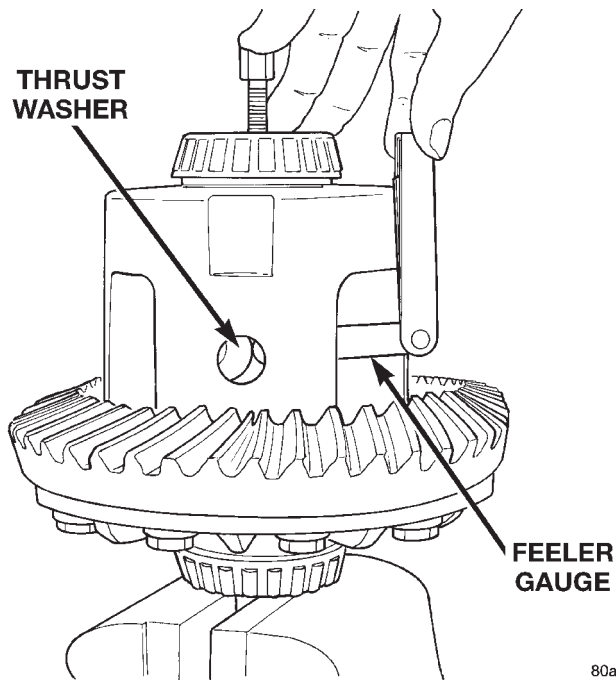


Fig. 64 Remove Pinion Gear Thrust Washer

(11) Insert Turning Bar C-6960-2 in case (Fig. 65).

(12) Loosen the Forcing Screw C-6960-4 in small increments until the clutch pack tension is relieved and the differential case can be turned using Turning Bar C-6960-2.

(13) Rotate differential case until the pinion gears can be removed.

(14) Remove pinion gears from differential case.

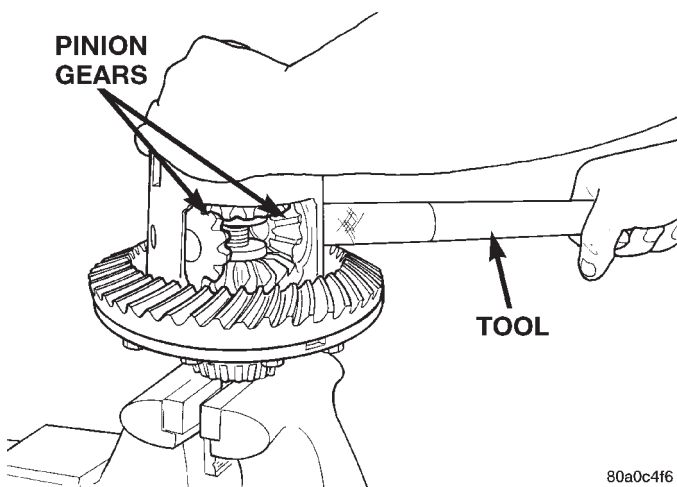


Fig. 65 Pinion Gear Removal

(15) Remove Forcing Screw C-6960-4, Step Plate C-6960-3, and Threaded Adapter C-6960-1.

(16) Remove top side gear, clutch pack retainer, and clutch pack. Keep plates in correct order during removal (Fig. 66).

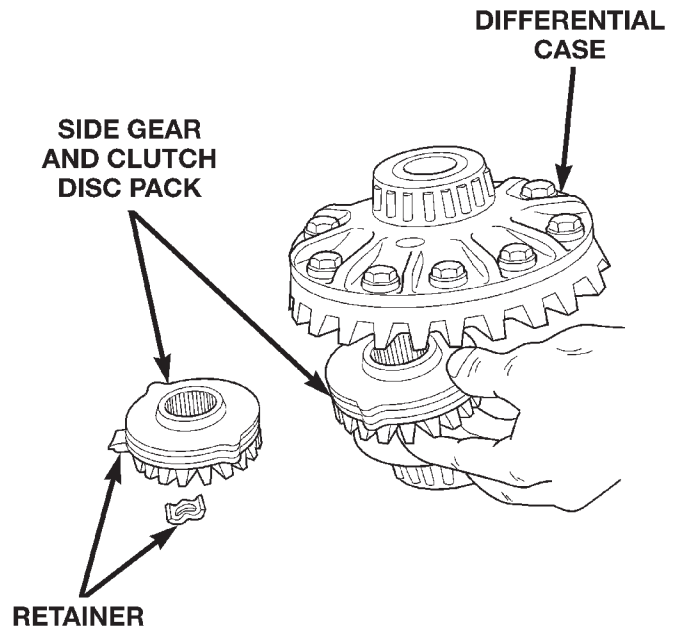


Fig. 66 Side Gear & Clutch Disc Removal

(17) Remove differential case from Side Gear Holding Tool 6965. Remove side gear, clutch pack retainer, and clutch pack. Keep plates in correct order during removal.

ASSEMBLY

NOTE: The clutch discs are replaceable as complete sets only. If one clutch disc pack is damaged, both packs must be replaced.

Lubricate each component with gear lubricant before assembly.

(1) Assemble the clutch discs into packs and secure disc packs with retaining clips (Fig. 67).

(2) Position assembled clutch disc packs on the side gear hubs.

(3) Install clutch pack and side gear in the ring gear side of the differential case (Fig. 68). **Be sure clutch pack retaining clips remain in position and are seated in the case pockets.**

(4) Position the differential case on Side Gear Holding Tool 6965.

(5) Install lubricated Step Plate C-6960-3 in lower side gear (Fig. 69).

(6) Install the upper side gear and clutch disc pack (Fig. 69).

(7) Hold assembly in position. Insert Threaded Adapter C-6960-1 into top side gear.

(8) Insert Forcing Screw C-6960-4.

DISASSEMBLY AND ASSEMBLY (Continued)

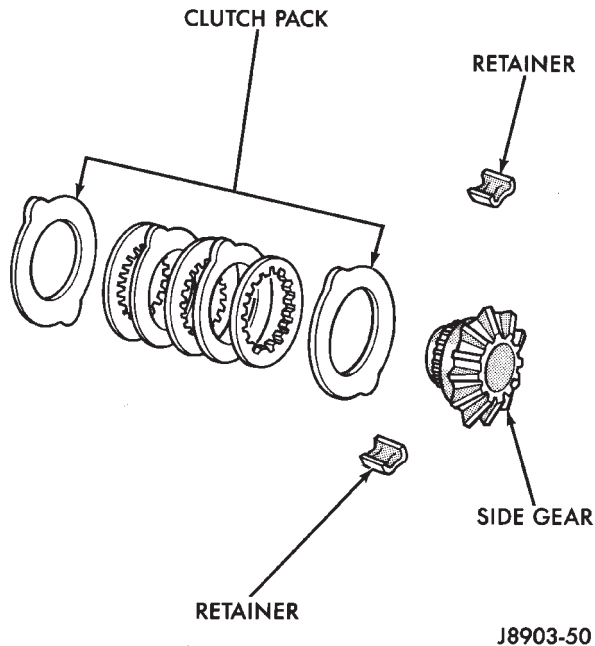


Fig. 67 Clutch Disc Pack

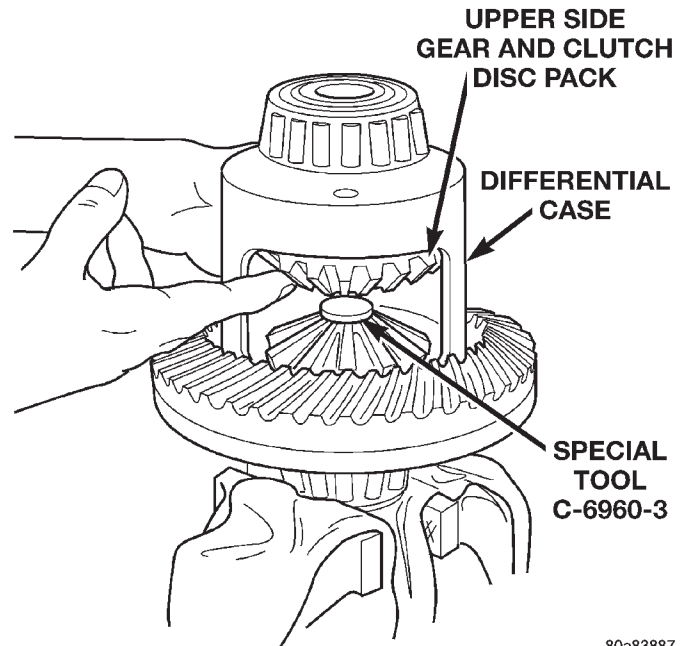


Fig. 69 Upper Side Gear & Clutch Disc Pack Installation

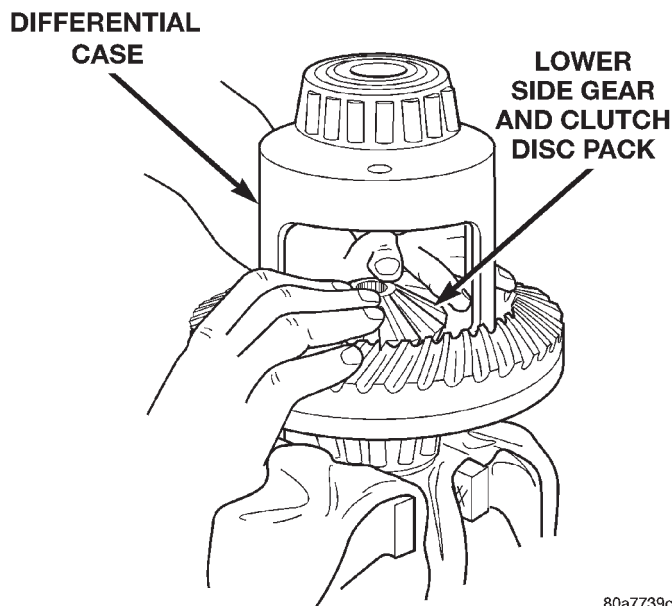


Fig. 68 Clutch Discs & Lower Side Gear Installation

(9) Tighten forcing screw tool to slightly compress clutch discs.

(10) Place pinion gears in position in side gears and verify that the pinion mate shaft hole is aligned.

(11) Rotate case with Turning Bar C-6960-2 until the pinion mate shaft holes in pinion gears align with holes in case. It may be necessary to slightly tighten the forcing screw in order to install the pinion gears.

(12) Tighten forcing screw to 122 N·m (90 ft. lbs.) maximum to compress the Belleville springs.

(13) Lubricate and install thrust washers behind pinion gears and align washers with a small screw driver. Insert mate shaft into each pinion gear to verify alignment.

(14) Remove Forcing Screw C-6960-4, Step Plate C-6960-3, and Threaded Adapter C-6960-1.

(15) Install pinion gear mate shaft and align holes in shaft and case.

(16) Install the pinion mate shaft lock screw finger tight to hold shaft during differential installation.

If replacement gears and thrust washers were installed, it is not necessary to measure the gear backlash. Correct fit is due to close machining tolerances during manufacture.

(17) Lubricate all differential components with hypoid gear lubricant.

CLEANING AND INSPECTION

AXLE COMPONENTS

Wash differential components with cleaning solvent and dry with compressed air. **Do not steam clean the differential components.**

Wash bearings with solvent and towel dry, or dry with compressed air. **DO NOT spin bearings with compressed air. Cup and bearing must be replaced as matched sets only.**

Clean axle shaft tubes and oil channels in housing. Inspect for;

CLEANING AND INSPECTION (Continued)

- Smooth appearance with no broken/dented surfaces on the bearing rollers or the roller contact surfaces.
- Bearing cups must not be distorted or cracked.
- Machined surfaces should be smooth and without any raised edges.
- Raised metal on shoulders of cup bores should be removed with a hand stone.
- Wear and damage to pinion gear mate shaft, pinion gears, side gears and thrust washers. Replace as a matched set only.
- Ring and pinion gear for worn and chipped teeth.
- Ring gear for damaged bolt threads. Replaced as a matched set only.
- Pinion yoke for cracks, worn splines, pitted areas, and a rough/corroded seal contact surface. Repair or replace as necessary.
- Preload shims for damage and distortion. Install new shims, if necessary.

TRAC-LOK

Clean all components in cleaning solvent. Dry components with compressed air. Inspect clutch pack plates for wear, scoring or damage. Replace both clutch packs if any one component in either pack is damaged. Inspect side and pinion gears. Replace any gear that is worn, cracked, chipped or damaged. Inspect differential case and pinion shaft. Replace if worn or damaged.

PRESOAK PLATES AND DISC

Plates and discs with fiber coating (no grooves or lines) must be presoaked in Friction Modifier before assembly. Soak plates and discs for a minimum of 20 minutes.

ADJUSTMENTS

PINION GEAR DEPTH

GENERAL INFORMATION

Ring and pinion gears are supplied as matched sets only. The identifying numbers for the ring and pinion gear are etched into the face of each gear (Fig. 70). A plus (+) number, minus (-) number or zero (0) is etched into the face of the pinion gear. This number is the amount (in thousandths of an inch) the depth varies from the standard depth setting of a pinion etched with a (0). The standard setting from the center line of the ring gear to the back face of the pinion is 96.850 mm (3.813 in.). The standard depth provides the best teeth contact pattern. Refer to Backlash and Contact Pattern Analysis Paragraph in this section for additional information.

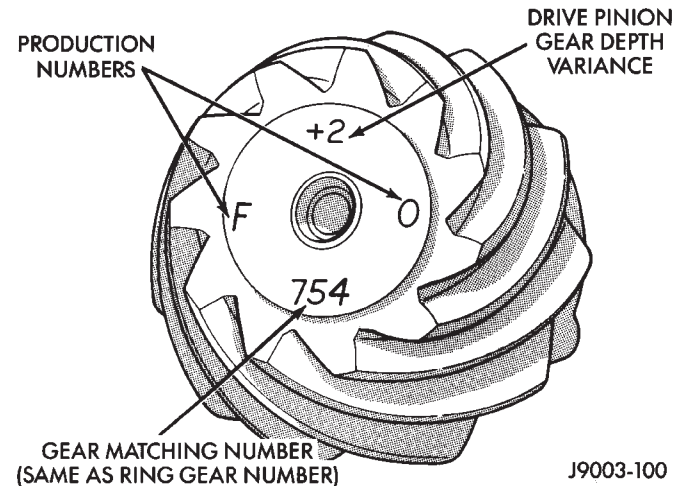


Fig. 70 Pinion Gear ID Numbers

Compensation for pinion depth variance is achieved with select shims. The shims are placed under the inner pinion bearing cone (Fig. 71).

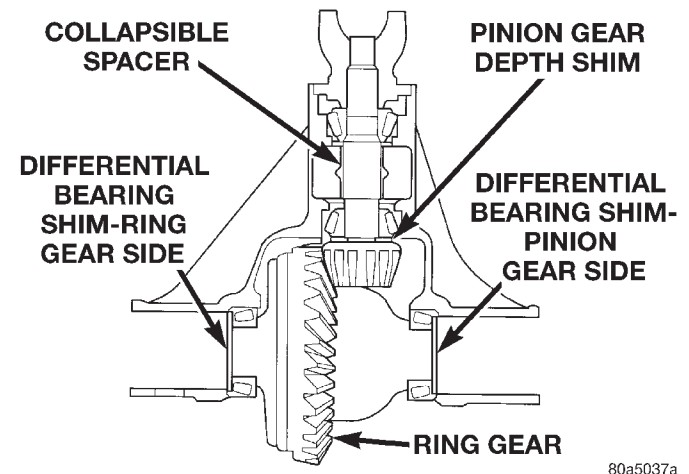


Fig. 71 Shim Locations

If a new gear set is being installed, note the depth variance etched into both the original and replacement pinion gear. Add or subtract the thickness of the original depth shims to compensate for the difference in the depth variances. Refer to the Depth Variance charts.

Note where Old and New Pinion Marking columns intersect. Intersecting figure represents plus or minus amount needed.

Note the etched number on the face of the drive pinion gear (-1, -2, 0, +1, +2, etc.). The numbers represent thousands of an inch deviation from the standard. If the number is negative, add that value to the required thickness of the depth shim(s). If the number is positive, subtract that value from the thickness of the depth shim(s). If the number is 0 no change is necessary. Refer to the Pinion Gear Depth Variance Chart.

ADJUSTMENTS (Continued)

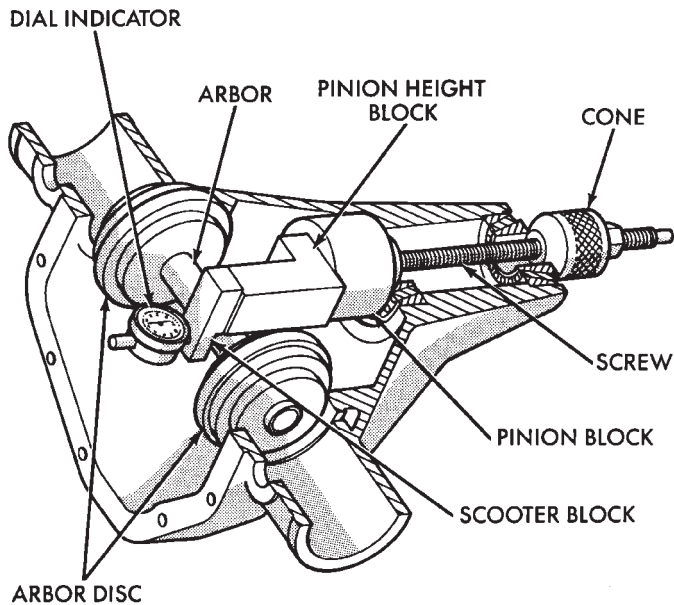
PINION GEAR DEPTH VARIANCE

Original Pinion Gear Depth Variance	Replacement Pinion Gear Depth Variance								
	-4	-3	-2	-1	0	+1	+2	+3	+4
+4	+0.008	+0.007	+0.006	+0.005	+0.004	+0.003	+0.002	+0.001	0
+3	+0.007	+0.006	+0.005	+0.004	+0.003	+0.002	+0.001	0	-0.001
+2	+0.006	+0.005	+0.004	+0.003	+0.002	+0.001	0	-0.001	-0.002
+1	+0.005	+0.004	+0.003	+0.002	+0.001	0	-0.001	-0.002	-0.003
0	+0.004	+0.003	+0.002	+0.001	0	-0.001	-0.002	-0.003	-0.004
-1	+0.003	+0.002	+0.001	0	-0.001	-0.002	-0.003	-0.004	-0.005
-2	+0.002	+0.001	0	-0.001	-0.002	-0.003	-0.004	-0.005	-0.006
-3	+0.001	0	-0.001	-0.002	-0.003	-0.004	-0.005	-0.006	-0.007
-4	0	-0.001	-0.002	-0.003	-0.004	-0.005	-0.006	-0.007	-0.008

J8902-46

PINION DEPTH MEASUREMENT AND ADJUSTMENT

Measurements are taken with pinion cups and pinion bearings installed in housing. Take measurements with a Pinion Gauge Set, Pinion Block 6735, Arbor Discs 6732, and Dial Indicator C-3339 (Fig. 72).



J9403-45

Fig. 72 Pinion Gear Depth Gauge Tools—Typical

(1) Assemble Pinion Height Block 6739, Pinion Block 6735, and rear pinion bearing onto Screw 6741 (Fig. 72).

(2) Insert assembled height gauge components, rear bearing and screw into axle housing through pinion bearing cups (Fig. 73).

(3) Install front pinion bearing and Cone 6740 hand tight (Fig. 72).

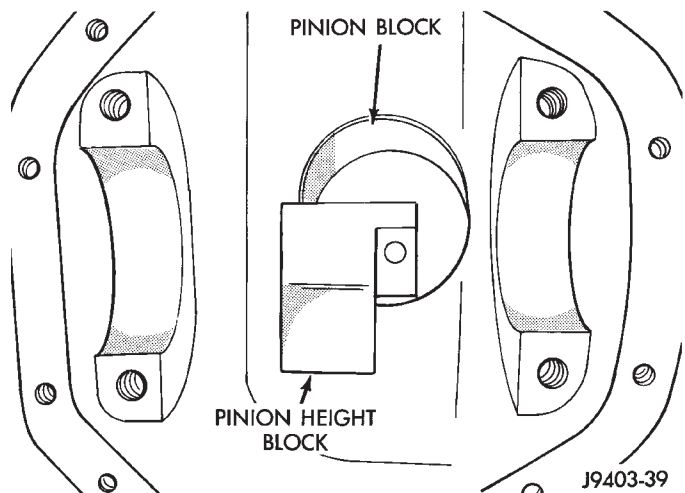


Fig. 73 Pinion Height Block—Typical

(4) Place Arbor Disc 6732 on Arbor D-115-3 in position in axle housing side bearing cradles (Fig. 74). Install differential bearing caps on Arbor Discs and tighten cap bolts. Refer to the Torque Specifications in this section.

ADJUSTMENTS (Continued)

NOTE: Arbor Discs 6732 have different step diameters to fit other axle sizes. Pick correct size step for axle being serviced.

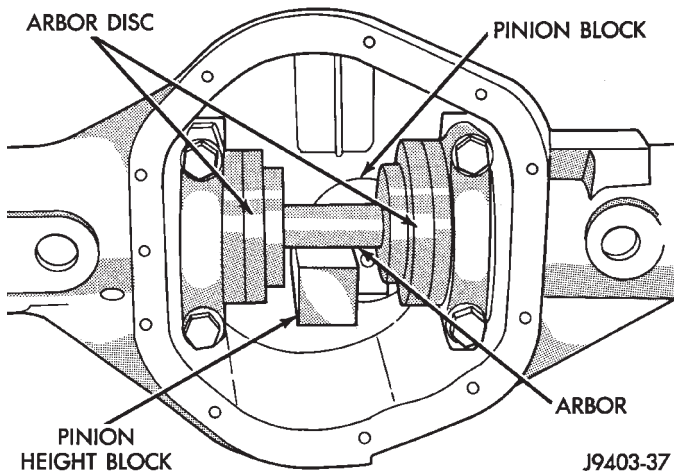


Fig. 74 Gauge Tools In Housing—Typical

(5) Assemble Dial Indicator C-3339 into Scooter Block D-115-2 and secure set screw.

(6) Place Scooter Block/Dial Indicator in position in axle housing so dial probe and scooter block are flush against the surface of the pinion height block. Hold scooter block in place and zero the dial indicator face to the pointer. Tighten dial indicator face lock screw.

(7) With scooter block still in position against the pinion height block, slowly slide the dial indicator probe over the edge of the pinion height block. Observe how many revolutions counterclockwise the dial pointer travels (approximately 0.125 in.) to the out-stop of the dial indicator.

(8) Slide the dial indicator probe across the gap between the pinion height block and the arbor bar with the scooter block against the pinion height block (Fig. 75). When the dial probe contacts the arbor bar, the dial pointer will turn clockwise. Bring dial pointer back to zero against the arbor bar, do not turn dial face. Continue moving the dial probe to the crest of the arbor bar and record the highest reading. If the dial indicator can not achieve the zero reading, the rear bearing cup or the pinion depth gauge set is not installed correctly.

(9) Select a shim equal to the dial indicator reading plus the drive pinion gear depth variance number etched in the face of the pinion gear (Fig. 70) using the opposite sign on the variance number. For example, if the depth variance is -2 , add $+0.002$ in. to the dial indicator reading.

(10) Remove the pinion depth gauge components from the axle housing

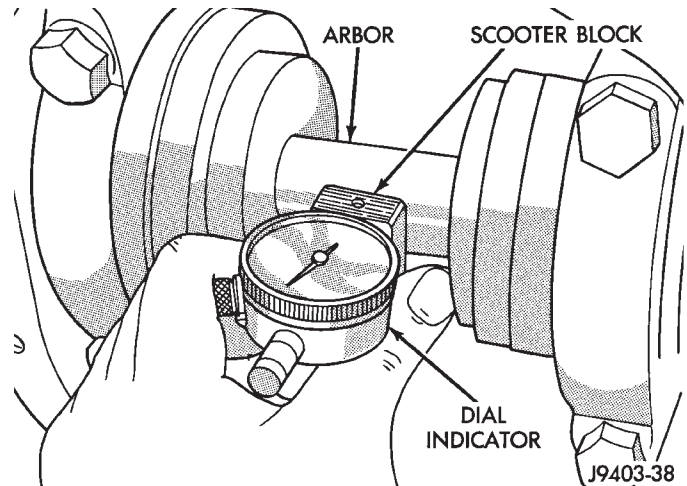


Fig. 75 Pinion Gear Depth Measurement—Typical

DIFFERENTIAL BEARING PRELOAD AND GEAR BACKLASH

Differential side bearing preload and gear backlash is achieved by selective shims inserted between the bearing cup and the axle housing. The proper shim thickness can be determined using slip-fit dummy bearings D-348 in place of the differential side bearings and a dial indicator C-3339. Before proceeding with the differential bearing preload and gear backlash measurements, measure the pinion gear depth and prepare the pinion gear for installation. Establishing proper pinion gear depth is essential to establishing gear backlash and tooth contact patterns. After the overall shim thickness to take up differential side play is measured, the pinion gear is installed, and the gear backlash shim thickness is measured. The overall shim thickness is the total of the dial indicator reading, starting point shim thickness, and the preload specification added together. The gear backlash measurement determines the thickness of the shim used on the ring gear side of the differential case. Subtract the gear backlash shim thickness from the total overall shim thickness and select that amount for the pinion gear side of the differential (Fig. 76).

SHIM SELECTION

NOTE: It is difficult to salvage the differential side bearings during the removal procedure. Install replacement bearings if necessary.

- (1) Remove side bearings from differential case.
- (2) Install ring gear, if necessary, on differential case and tighten bolts to specification.
- (3) Install dummy side bearings D-348 on differential case.
- (4) Install differential case in axle housing.

ADJUSTMENTS (Continued)

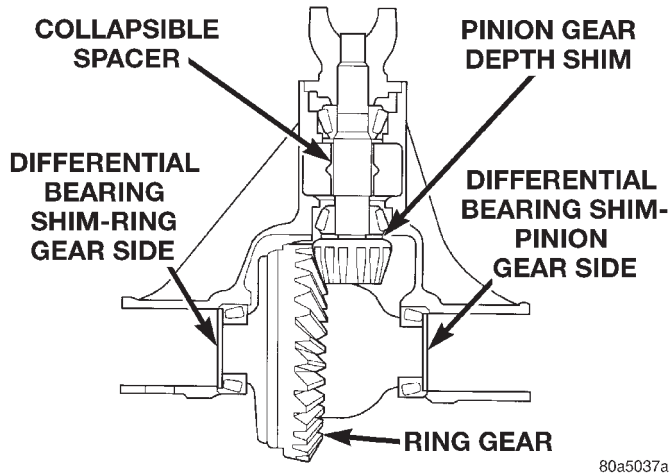


Fig. 76 Axle Adjustment Shim Locations

(5) Insert Dummy Shims 8107 (0.118 in. (3.0 mm)) starting point shims between the dummy bearing and the axle housing (Fig. 77).

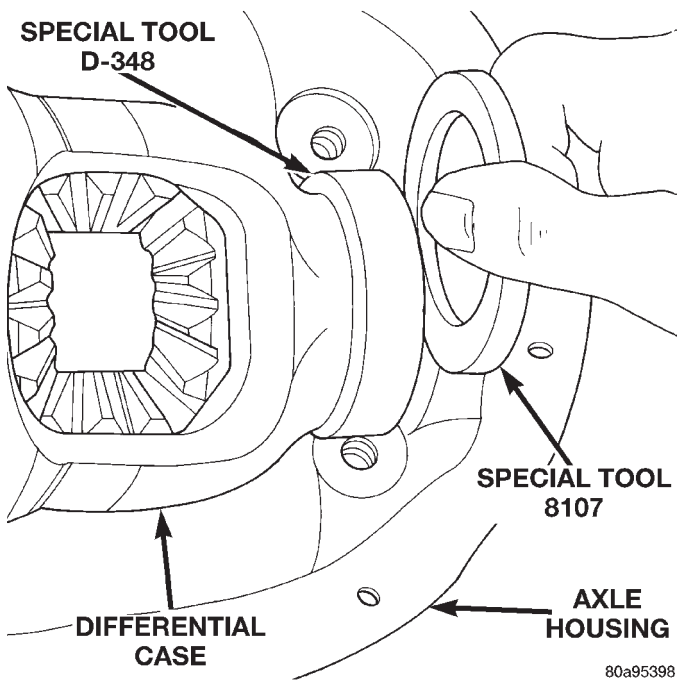


Fig. 77 Insert Starting Point Shims

- (6) Install the marked bearing caps in their correct positions. Install and tighten the bolts.
- (7) Thread guide stud C-3288-B into rear cover bolt hole below ring gear (Fig. 78).
- (8) Attach dial indicator C-3339 to guide stud. Position the dial indicator plunger on a flat surface on a ring gear bolt head (Fig. 78).
- (9) Push firmly and hold differential case to pinion gear side of axle housing.
- (10) Zero dial indicator face to pointer.
- (11) Push firmly and hold differential case to ring gear side of the axle housing.

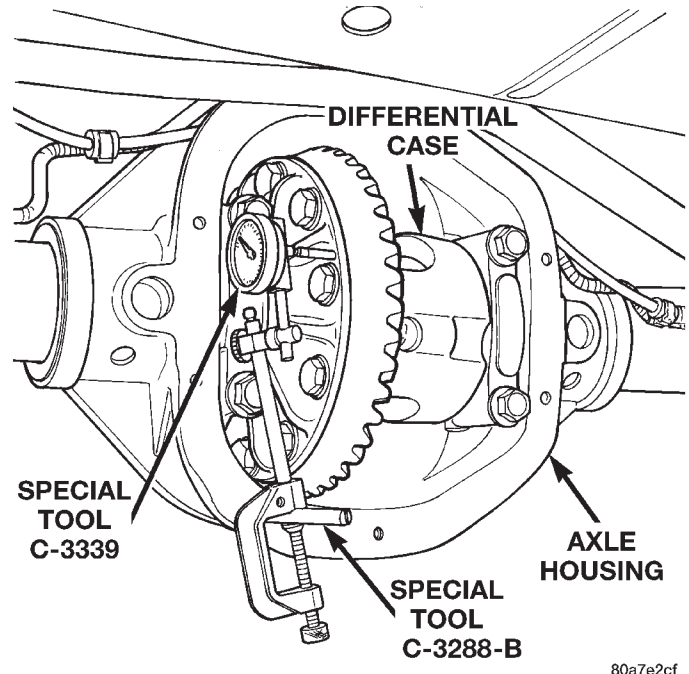


Fig. 78 Differential Side play Measurement

- (12) Record dial indicator reading.
- (13) Add the dial indicator reading to the starting point shim thickness to determine total shim thickness to achieve zero differential end play.
- (14) Add 0.008 in. (0.2 mm) to the zero end play total. This new total represents the thickness of shims to compress, or preload the new bearings when the differential is installed.
- (15) Rotate dial indicator out of the way on guide stud.
- (16) Remove differential case, dummy bearings, and starting point shims from axle housing.
- (17) Install pinion gear in axle housing. Install the yoke and establish the correct pinion rotating torque.
- (18) Install differential case and dummy bearings in axle housing (without shims) and tighten retaining cap bolts.
- (19) Position the dial indicator plunger on a flat surface between the ring gear bolt heads (Fig. 78).
- (20) Push and hold differential case toward pinion gear.
- (21) Zero dial indicator face to pointer.
- (22) Push and hold differential case to ring gear side of the axle housing.
- (23) Record dial indicator reading.
- (24) Subtract 0.002 in. (0.05 mm) from the dial indicator reading to compensate for backlash between ring and pinion gears. This total is the thickness of shim required to achieve proper backlash.
- (25) Subtract the backlash shim thickness from the total preload shim thickness. The remainder is the shim thickness required on the pinion side of the axle housing.

ADJUSTMENTS (Continued)

(26) Rotate dial indicator out of the way on guide stud.

(27) Remove differential case and dummy bearings from axle housing.

(28) Install new side bearing cones and cups on differential case.

(29) Install spreader W-129-B, utilizing some components of Adapter Set 6987, on axle housing and spread axle opening enough to receive differential case.

(30) Place side bearing shims in axle housing against axle tubes.

(31) Install differential case in axle housing.

(32) Rotate the differential case several times to seat the side bearings.

(33) Position the indicator plunger against a ring gear tooth (Fig. 79).

(34) Push and hold ring gear upward while not allowing the pinion gear to rotate.

(35) Zero dial indicator face to pointer.

(36) Push and hold ring gear downward while not allowing the pinion gear to rotate. Dial indicator reading should be between 0.12 mm (0.005 in.) and 0.20 mm (0.008 in.). If backlash is not within specifications transfer the necessary amount of shim thickness from one side of the differential housing to the other (Fig. 80).

(37) Verify differential case and ring gear runout by measuring ring to pinion gear backlash at several locations around the ring gear. Readings should not vary more than 0.05 mm (0.002 in.). If readings vary more than specified, the ring gear or the differential case is defective.

After the proper backlash is achieved, perform the Gear Contact Pattern Analysis procedure.

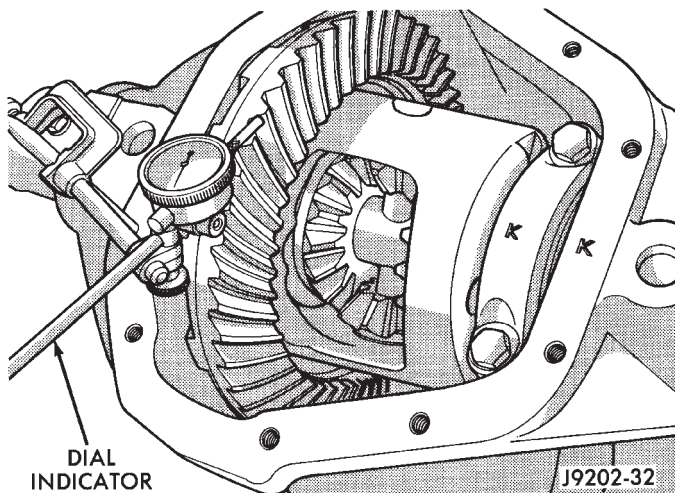


Fig. 79 Ring Gear Backlash Measurement

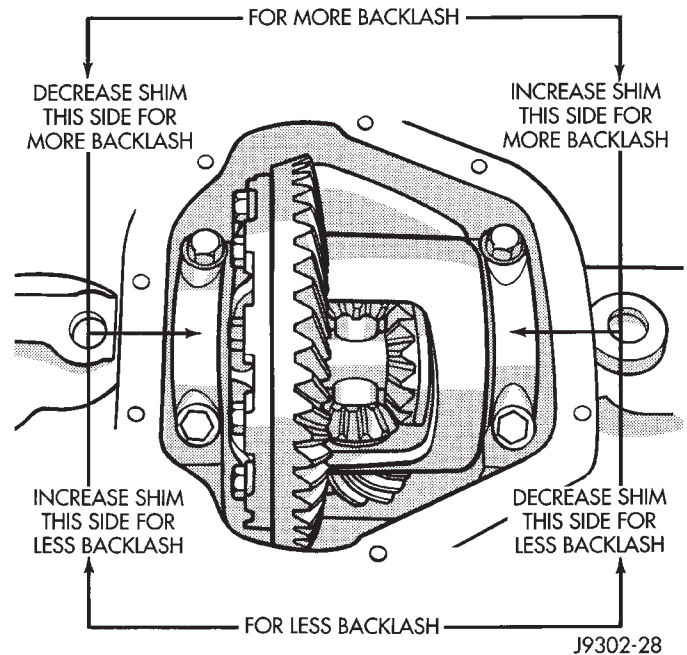


Fig. 80 Backlash Shim Adjustment

GEAR CONTACT PATTERN ANALYSIS

The ring and pinion gear teeth contact patterns will show if the pinion gear depth is correct in the axle housing. It will also show if the ring gear backlash has been adjusted correctly. The backlash can be adjusted within specifications to achieve desired tooth contact patterns.

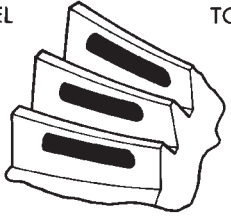
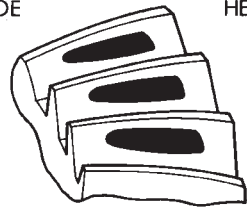
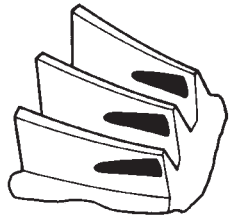
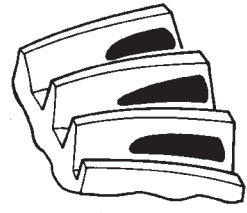
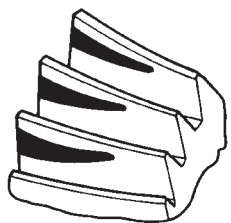
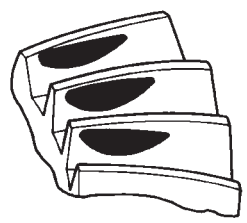
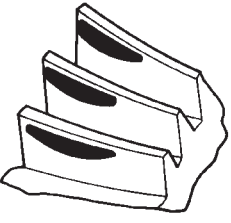
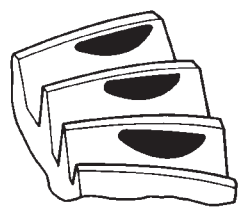
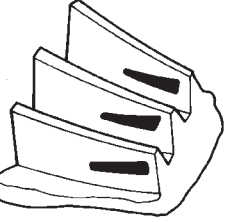
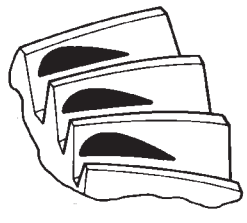
(1) Apply a thin coat of hydrated ferric oxide, or equivalent, to the drive and coast side of the ring gear teeth.

(2) Wrap, twist, and hold a shop towel around the pinion yoke to increase the turning resistance of the pinion gear. This will provide a more distinct contact pattern.

(3) Using a boxed end wrench on a ring gear bolt, rotate the differential case one complete revolution in both directions while a load is being applied from shop towel.

The areas on the ring gear teeth with the greatest degree of contact against the pinion gear teeth will squeegee the compound to the areas with the least amount of contact. Note and compare patterns on the ring gear teeth to Gear Tooth Contact Patterns chart (Fig. 81) and adjust pinion depth and gear backlash as necessary.

ADJUSTMENTS (Continued)

<p>DRIVE SIDE OF RING GEAR TEETH</p> <p>HEEL TOE</p> 	<p>COAST SIDE OF RING GEAR TEETH</p> <p>TOE HEEL</p> 	<p>DESIRABLE CONTACT PATTERN. PATTERN SHOULD BE CENTERED ON THE DRIVE SIDE OF TOOTH. PATTERN SHOULD BE CENTERED ON THE COAST SIDE OF TOOTH, BUT MAY BE SLIGHTLY TOWARD THE TOE. THERE SHOULD ALWAYS BE SOME CLEARANCE BETWEEN CONTACT PATTERN AND TOP OF THE TOOTH.</p>
		<p>RING GEAR BACKLASH CORRECT. THINNER PINION GEAR DEPTH SHIM REQUIRED.</p>
		<p>RING GEAR BACKLASH CORRECT. THICKER PINION GEAR DEPTH SHIM REQUIRED.</p>
		<p>PINION GEAR DEPTH SHIM CORRECT. DECREASE RING GEAR BACKLASH.</p>
		<p>PINION GEAR DEPTH SHIM CORRECT. INCREASE RING GEAR BACKLASH.</p>

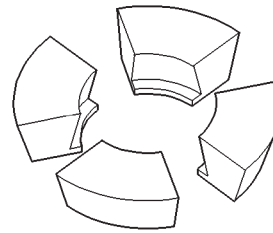
J9003-24

Fig. 81 Gear Tooth Contact Patterns

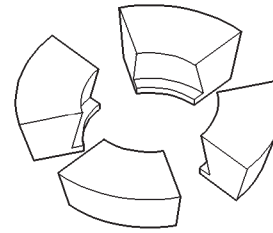
SPECIFICATIONS

194 RBI AXLE

DESCRIPTION	SPECIFICATION
Axle Type	Semi-Floating Hypoid
Lubricant.	SAE Thermally Stable 80W-90
Lubricant Trailer Tow	Synthetic 75W-140
Lube Capacity	1.66 L (3.50 pts.)
Axle Ratios.	3.07, 3.55, 3.73, 4.10
Differential Bearing Preload	0.1 mm (0.004 in.)
Differential Side Gear Clearance	0-0.15 mm (0-0.006 in.)
Ring Gear Diameter	19.2 cm (7.562 in.)
Ring Gear Backlash.	0-0.15 mm (0.005-0.008 in.)
Pinion Std. Depth	92.08 mm (3.625 in.)
Pinion Bearing Preload-Original Bearings	1-2 N·m (10-20 in. lbs.)
Pinion Bearing Preload-New Bearings	1.5-4 N·m (15-35 in. lbs.)
Maximum Carrier Spread	0.51 mm (0.020 in.)



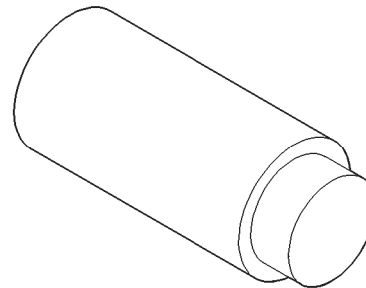
Adapter—C-293-39



Adapter—C-293-40

194 RBI AXLE

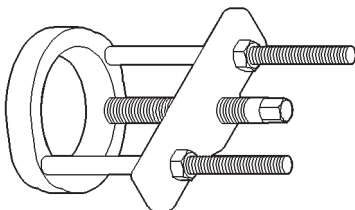
DESCRIPTION	TORQUE
Bolt, Diff. Cover	41 N·m (30 ft. lbs.)
Bolt, Bearing Cap	77 N·m (57 ft. lbs.)
Nut, Pinion	271-474 N·m (200-350 ft. lbs.)
Screw, Pinion Mate	
Shaft Lock	16.25 N·m (12 ft. lbs.)
Bolt, Ring Gear	95-122 N·m (70-90 ft. lbs.)
Bolt, ABS Sensor8 N·m (70 in. lbs.)



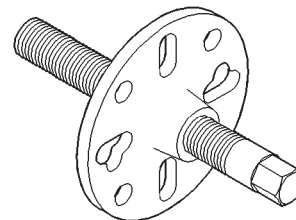
Plug—SP-3289

SPECIAL TOOLS

194 RBI AXLE

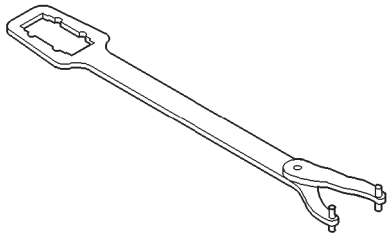


Puller—C-293-PA

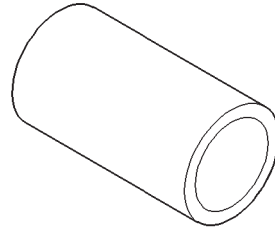


Puller—C-452

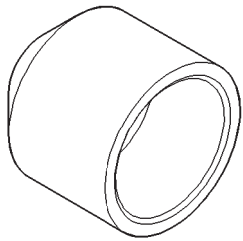
SPECIAL TOOLS (Continued)



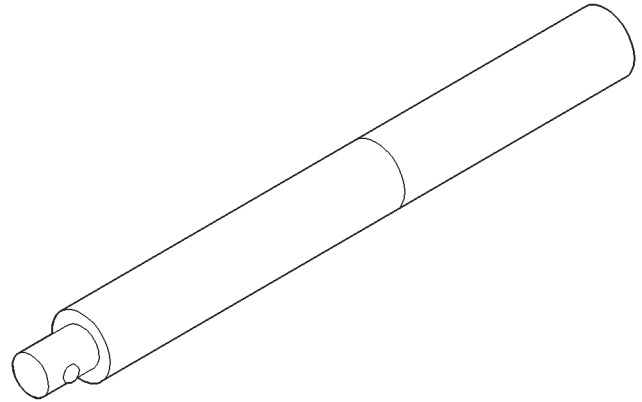
Wrench—C-3281



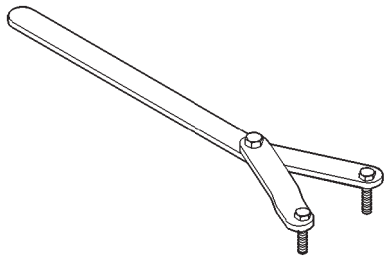
Cup—8109



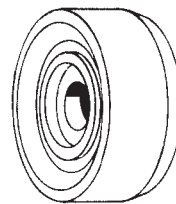
Installer—C-3972-A



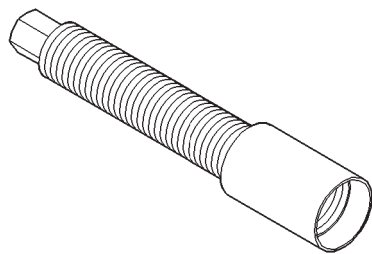
Handle—C-4171



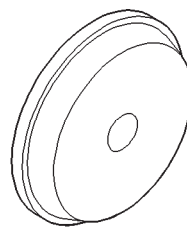
Spanner—6958



Driver—C-3716-A

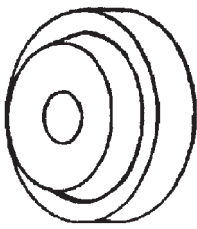


Installer Screw—8112

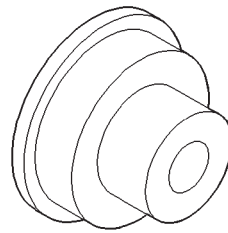


Installer—D-130

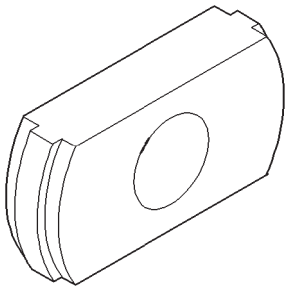
SPECIAL TOOLS (Continued)



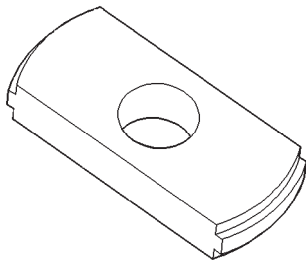
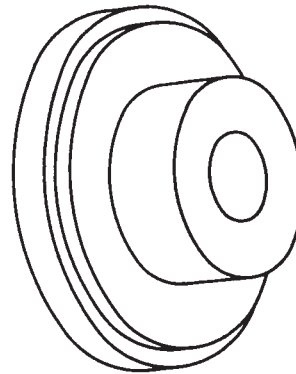
Installer—D-146



Installer—6436

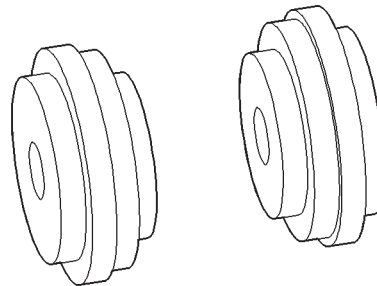


Remover—C-4345

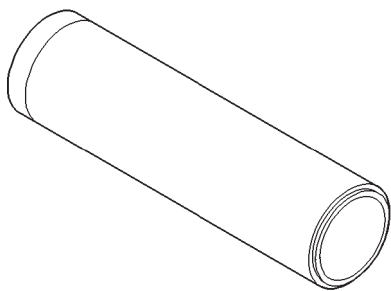


Remover—D-149

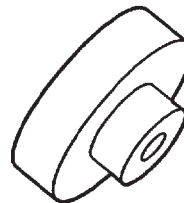
Installer—6437



Disc, Axle Arbor—6732

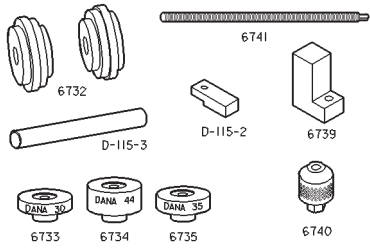


Installer—W-262

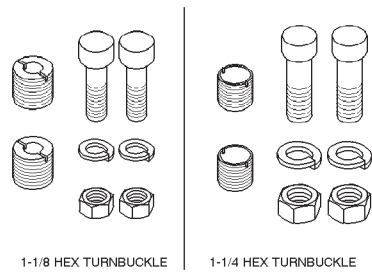


Gauge Block—6735

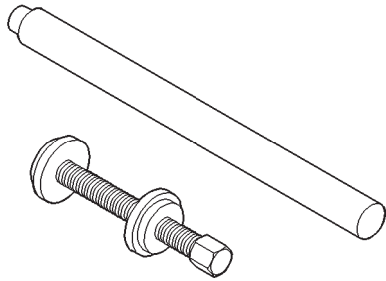
SPECIAL TOOLS (Continued)



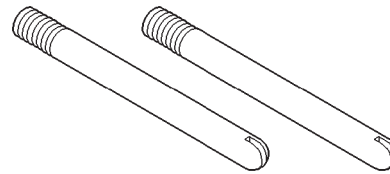
Tool Set, Pinion Depth—6774



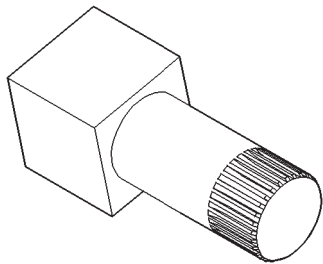
Adapter Kit—6987



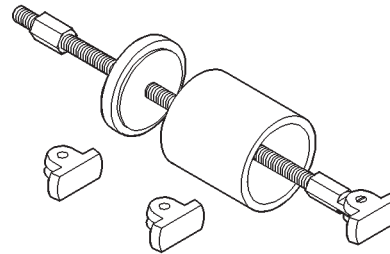
Trac-lok Tool Set—6960



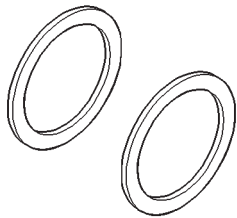
Guide Pin—C-3288-B



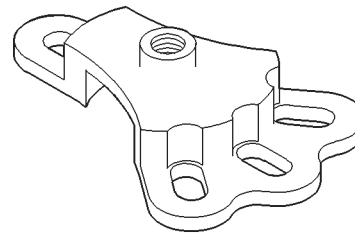
Holder—6965



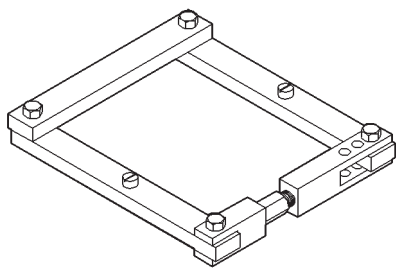
Bearing Remover Tool Set—6310



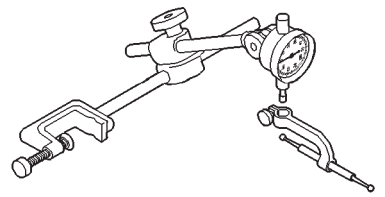
Starting Point Shim—8107



Hub Puller—6790



Spreader—W-129-B



Dial Indicator—C-3339

8011d42b

216 RBA AXLE

INDEX

	page		page
GENERAL INFORMATION			
216 RBA AXLE	88	DIFFERENTIAL	101
LUBRICANT SPECIFICATIONS	88	FINAL ASSEMBLY	108
DESCRIPTION AND OPERATION			
STANDARD DIFFERENTIAL	89	PINION GEAR	104
TRAC-LOK OPERATION	89	PINION SHAFT SEAL	95
DIAGNOSIS AND TESTING			
BEARING NOISE	90	REAR AXLE	94
DRIVELINE SNAP	91	RING GEAR	103
GEAR NOISE	90	DISASSEMBLY AND ASSEMBLY	
GENERAL INFORMATION	90	STANDARD DIFFERENTIAL	108
LOW SPEED KNOCK	91	TRAC-LOK DIFFERENTIAL	108
TRAC-LOK DIFFERENTIAL NOISE	91	CLEANING AND INSPECTION	
TRAC-LOK TEST	94	AXLE COMPONENTS	112
VIBRATION	91	TRAC-LOK	113
SERVICE PROCEDURES			
LUBRICANT CHANGE	94	ADJUSTMENTS	
REMOVAL AND INSTALLATION			
AXLE SHAFT SEAL AND BEARING	100	DIFFERENTIAL BEARING PRELOAD AND	
AXLE SHAFT	99	GEAR BACKLASH	115
COLLAPSIBLE SPACER	97	GEAR CONTACT PATTERN ANALYSIS	117
DIFFERENTIAL SIDE BEARINGS	103	PINION GEAR DEPTH	113
		SPECIFICATIONS	
		216 RBA AXLE	119
		TORQUE	119
		SPECIAL TOOLS	
		216 RBA AXLE	119

GENERAL INFORMATION

216 RBA AXLE

The 216 Rear Beam-design Aluminum (RBA) axle housing has an aluminum center casting (differential housing) with axle shaft tubes extending from either side. The tubes are pressed into the differential housing to form a one-piece axle housing.

The integral type housing, hypoid gear design has the center-line of the pinion set below the center-line of the ring gear.

The axle has a vent hose to relieve internal pressure caused by lubricant vaporization and internal expansion.

The axles are equipped with semi-floating axle shafts, meaning that vehicle load is supported by the axle shaft and bearings. The axle shafts are retained by C-clips in the differential side gears.

The cover provides a means for servicing the differential without removing the axle.

For vehicles equipped with ABS brakes, the axles have a tone ring pressed onto the axle shaft. Use care when removing axle shafts to ensure that the tone wheel or the wheel speed sensor are not damaged.

The 216 RBA axle has the assembly part number and gear ratio listed on a tag. The tag is attached to the differential housing by a cover bolt. Build date identification codes are stamped on the cover side of an axle shaft tube.

The differential case is a one-piece design. The differential pinion mate shaft is retained with a threaded pin. Differential bearing preload and ring gear backlash is adjusted by the use of selective spacer shims. Pinion bearing preload is set and maintained by the use of a collapsible spacer (Fig. 1).

LUBRICANT SPECIFICATIONS

A multi-purpose, hypoid gear lubricant which conforms to the following specifications should be used. Mopar® Hypoid Gear Lubricant conforms to all of these specifications.

- The lubricant should have MIL-L-2105C and API GL 5 quality specifications.
- Lubricant is a thermally stable SAE 80W-90 gear lubricant.
- Lubricant for axles intended for heavy-duty or trailer tow use is SAE 75W-140 SYNTHETIC gear lubricant.

Trac-lok differentials require the addition of 4 oz. of friction modifier to the axle lubricant. The 216

GENERAL INFORMATION (Continued)

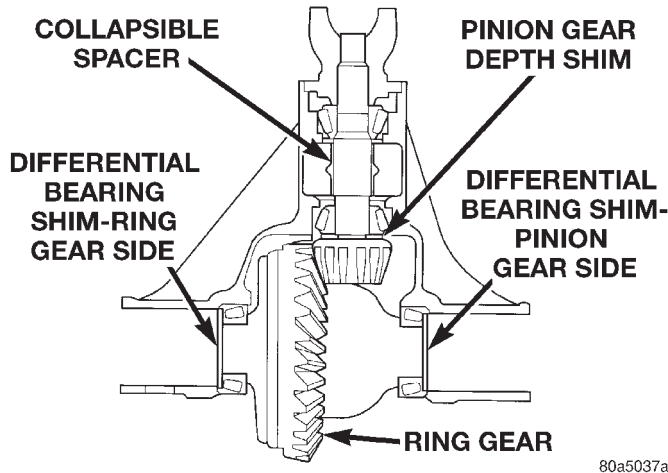


Fig. 1 Shim Locations

RBA axle lubricant capacity is 2.25 L (4.75 pts.) total, including the friction modifier if necessary.

CAUTION: If axle is submerged in water, lubricant must be replaced immediately to avoid possible premature axle failure.

DESCRIPTION AND OPERATION

STANDARD DIFFERENTIAL

The differential gear system divides the torque between the axle shafts. It allows the axle shafts to rotate at different speeds when turning corners.

Each differential side gear is splined to an axle shaft. The pinion gears are mounted on a pinion mate shaft and are free to rotate on the shaft. The pinion gear is fitted in a bore in the differential case and is positioned at a right angle to the axle shafts.

In operation, power flow occurs as follows:

- The pinion gear rotates the ring gear
- The ring gear (bolted to the differential case) rotates the case
- The differential pinion gears (mounted on the pinion mate shaft in the case) rotate the side gears
- The side gears (splined to the axle shafts) rotate the shafts

During straight-ahead driving, the differential pinion gears do not rotate on the pinion mate shaft. This occurs because input torque applied to the gears is divided and distributed equally between the two side gears. As a result, the pinion gears revolve with the pinion mate shaft but do not rotate around it (Fig. 2).

When turning corners, the outside wheel must travel a greater distance than the inside wheel to complete a turn. The difference must be compensated for to prevent the tires from scuffing and skidding through turns. To accomplish this, the differential allows the axle shafts to turn at unequal speeds (Fig.

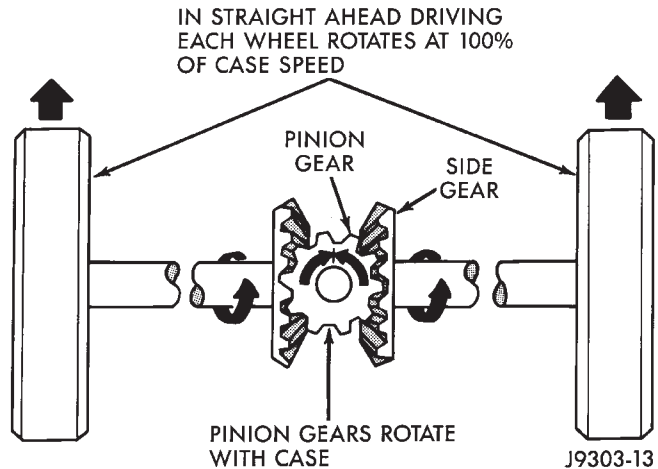


Fig. 2 Differential Operation—Straight Ahead Driving

3). In this instance, the input torque applied to the pinion gears is not divided equally. The pinion gears now rotate around the pinion mate shaft in opposite directions. This allows the side gear and axle shaft attached to the outside wheel to rotate at a faster speed.

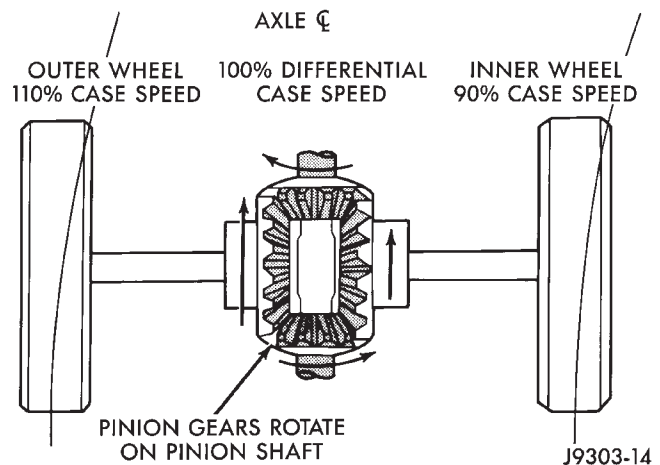


Fig. 3 Differential Operation—On Turns

TRAC-LOK OPERATION

In a conventional differential, if one wheel spins, the opposite wheel will generate only as much torque as the spinning wheel.

In the Trac-lok differential, part of the ring gear torque is transmitted through clutch packs which contain multiple discs. The clutches will have radial grooves on the plates, and concentric grooves on the discs or bonded fiber material that is smooth in appearance.

In operation, the Trac-lok clutches are engaged by two concurrent forces. The first being the preload force exerted through Belleville spring washers within the clutch packs. The second is the separating forces generated by the side gears as torque is applied through the ring gear (Fig. 4).

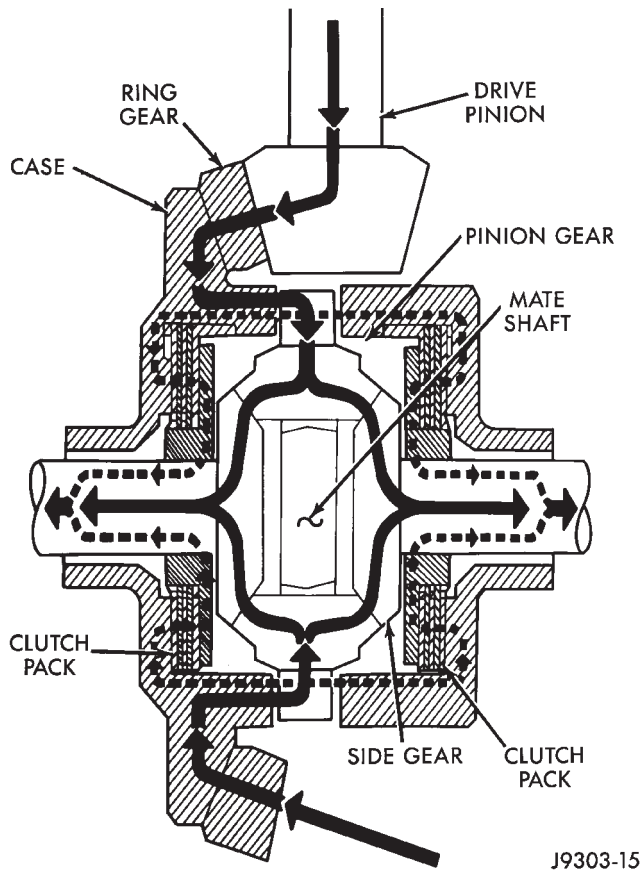
DESCRIPTION AND OPERATION (Continued)

Fig. 4 Trac-lok Limited Slip Differential Operation

The Trac-lok design provides the differential action needed for turning corners and for driving straight ahead during periods of unequal traction. When one wheel loses traction, the clutch packs transfer additional torque to the wheel having the most traction. Trac-lok differentials resist wheel spin on bumpy roads and provide more pulling power when one wheel loses traction. Pulling power is provided continuously until both wheels lose traction. If both wheels slip due to unequal traction, Trac-lok operation is normal. In extreme cases of differences of traction, the wheel with the least traction may spin.

DIAGNOSIS AND TESTING**GENERAL INFORMATION**

Axle bearing problem conditions are usually caused by:

- Insufficient or incorrect lubricant.
- Foreign matter/water contamination.
- Incorrect bearing preload torque adjustment.
- Incorrect backlash.

Axle gear problem conditions are usually the result of:

- Insufficient lubrication.
- Incorrect or contaminated lubricant.

- Overloading (excessive engine torque) or exceeding vehicle weight capacity.

- Incorrect clearance or backlash adjustment.

Axle component breakage is most often the result of:

- Severe overloading.
- Insufficient lubricant.
- Incorrect lubricant.
- Improperly tightened components.

GEAR NOISE

Axle gear noise can be caused by insufficient lubricant, incorrect backlash, tooth contact, or worn/damaged gears.

Gear noise usually happens at a specific speed range. The range is 30 to 40 mph, or above 50 mph. The noise can also occur during a specific type of driving condition. These conditions are acceleration, deceleration, coast, or constant load.

When road testing, accelerate the vehicle to the speed range where the noise is the greatest. Shift out-of-gear and coast through the peak-noise range. If the noise stops or changes greatly:

- Check for insufficient lubricant.
- Incorrect ring gear backlash.
- Gear damage.

Differential side and pinion gears can be checked by turning the vehicle. They usually do not cause noise during straight-ahead driving when the gears are unloaded. The side gears are loaded during vehicle turns. A worn pinion gear mate shaft can also cause a snapping or a knocking noise.

BEARING NOISE

The axle shaft, differential and pinion gear bearings can all produce noise when worn or damaged. Bearing noise can be either a whining, or a growling sound.

Pinion gear bearings have a constant-pitch noise. This noise changes only with vehicle speed. Pinion bearing noise will be higher because it rotates at a faster rate. Drive the vehicle and load the differential. If bearing noise occurs, the rear pinion bearing is the source of the noise. If the bearing noise is heard during a coast, the front pinion bearing is the source.

Worn or damaged differential bearings usually produce a low pitch noise. Differential bearing noise is similar to pinion bearing noise. The pitch of differential bearing noise is also constant and varies only with vehicle speed.

Axle shaft bearings produce noise and vibration when worn or damaged. The noise generally changes when the bearings are loaded. Road test the vehicle. Turn the vehicle sharply to the left and to the right. This will load the bearings and change the noise

DIAGNOSIS AND TESTING (Continued)

level. Where axle bearing damage is slight, the noise is usually not noticeable at speeds above 30 mph.

LOW SPEED KNOCK

Low speed knock is generally caused by a worn U-joint or by worn side-gear thrust washers. A worn pinion gear shaft bore will also cause low speed knock.

VIBRATION

Vibration at the rear of the vehicle is usually caused by a:

- Damaged drive shaft.
- Missing drive shaft balance weight(s).
- Worn or out-of-balance wheels.
- Loose wheel lug nuts.
- Worn U-joint(s).
- Loose/broken springs.
- Damaged axle shaft bearing(s).
- Loose pinion gear nut.
- Excessive pinion yoke run out.
- Bent axle shaft(s).

Check for loose or damaged front-end components or engine/transmission mounts. These components can contribute to what appears to be a rear-end vibration. Do not overlook engine accessories, brackets and drive belts.

All driveline components should be examined before starting any repair.

Refer to Group 22, Wheels and Tires, for additional vibration information.

DRIVELINE SNAP

A snap or clunk noise when the vehicle is shifted into gear (or the clutch engaged), can be caused by:

- High engine idle speed
- Loose engine/transmission/transfer case mounts
- Worn U-joints
- Loose spring mounts
- Loose pinion gear nut and yoke
- Excessive ring gear backlash
- Excessive side gear/case clearance

The source of a snap or a clunk noise can be determined with the assistance of a helper. Raise the vehicle on a hoist with the wheels free to rotate. Instruct the helper to shift the transmission into gear. Listen for the noise, a mechanics stethoscope is helpful in isolating the source of a noise.

TRAC-LOK DIFFERENTIAL NOISE

The most common problem is a chatter noise when turning corners. Before removing a Trac-lok unit for repair, drain, flush and refill the axle with the specified lubricant. Refer to Lubricant change in this Group.

A container of Mopar® Trac-lok Lubricant (friction modifier) should be added after repair service or during a lubricant change.

After changing the lubricant, drive the vehicle and make 10 to 12 slow, figure-eight turns. This maneuver will pump lubricant through the clutches. This will correct the condition in most instances. If the chatter persists, clutch damage could have occurred.

DIAGNOSIS AND TESTING (Continued)

DIAGNOSIS CHART

CONDITION	POSSIBLE CAUSES	CORRECTION
WHEEL NOISE	<ol style="list-style-type: none"> 1. Wheel loose. 2. Faulty, brinelled wheel bearing. 	<ol style="list-style-type: none"> 1. Tighten loose nuts. 2. Faulty or brinelled bearings must be replaced.
AXLE SHAFT NOISE	<ol style="list-style-type: none"> 1. Misaligned axle shaft tube. 2. Bent or sprung axle shaft. 3. End play in drive pinion bearings. 4. Excessive gear backlash between ring gear and pinion gear. 5. Improper adjustment of drive pinion gear shaft bearings. 6. Loose drive pinion gearshaft yoke nut. 7. Improper wheel bearing adjustment. 8. Scuffed gear tooth contact surfaces. 	<ol style="list-style-type: none"> 1. Inspect axle shaft tube alignment. Correct as necessary. 2. Replace bent or sprung axle shaft. 3. Refer to Drive Pinion Bearing Pre-Load Adjustment. 4. Check adjustment of ring gear backlash and pinion gear. Correct as necessary. 5. Adjust drive pinion shaft bearings. 6. Tighten drive pinion gearshaft yoke nut with specified torque. 7. Readjust as necessary. 8. If necessary, replace scuffed gears.
AXLE SHAFT BROKE	<ol style="list-style-type: none"> 1. Misaligned axle shaft tube. 2. Vehicle overloaded. 3. Erratic clutch operation. 4. Grabbing clutch. 	<ol style="list-style-type: none"> 1. Replace broken axle shaft after correcting axle shaft tube alignment. 2. Replace broken axle shaft. Avoid excessive weight on vehicle. 3. Replace broken axle shaft after inspecting for other possible causes. Avoid erratic use of clutch. 4. Replace broken axle shaft. Inspect clutch and make necessary repairs or adjustments.
DIFFERENTIAL CASE CRACKED	<ol style="list-style-type: none"> 1. Improper adjustment of differential bearings. 2. Excessive ring gear backlash. 3. Vehicle overloaded. 4. Erratic clutch operation. 	<ol style="list-style-type: none"> 1. Replace cracked case; examine gears and bearings for possible damage. At reassembly, adjust differential bearings properly. 2. Replace cracked case; examine gears and bearings for possible damage. At reassembly, adjust ring gear backlash properly. 3. Replace cracked case; examine gears and bearings for possible damage. Avoid excessive weight on vehicle. 4. Replace cracked case. After inspecting for other possible causes, examine gears and bearings for possible damage. Avoid erratic use of clutch.
DIFFERENTIAL GEARS SCORED	<ol style="list-style-type: none"> 1. Insufficient lubrication. 2. Improper grade of lubricant. 3. Excessive spinning of one wheel/tire. 	<ol style="list-style-type: none"> 1. Replace scored gears. Scoring marks on the drive face of gear teeth or in the bore are caused by instantaneous fusing of the mating surfaces. Scored gears should be replaced. Fill rear differential housing to required capacity with proper lubricant. Refer to Specifications. 2. Replace scored gears. Inspect all gears and bearings for possible damage. Clean and refill differential housing to required capacity with proper lubricant. 3. Replace scored gears. Inspect all gears, pinion bores and shaft for damage. Service as necessary.
LOSS OF LUBRICANT	<ol style="list-style-type: none"> 1. Lubricant level too high. 	<ol style="list-style-type: none"> 1. Drain excess lubricant by removing fill plug and allow lubricant to level at lower edge of fill plug hole.

DIAGNOSIS AND TESTING (Continued)

CONT., DIAGNOSIS CHART

CONDITION	POSSIBLE CAUSES	CORRECTION
LOSS OF LUBRICANT	<ol style="list-style-type: none"> 2. Worn axle shaft seals. 3. Cracked differential housing. 4. Worn drive pinion gear shaft seal. 5. Scored and worn yoke. 6. Axle cover not properly sealed. 	<ol style="list-style-type: none"> 2. Replace worn seals. 3. Repair or replace housing as necessary. 4. Replace worn drive pinion gear shaft seal. 5. Replace worn or scored yoke and seal. 6. Remove cover and clean flange and reseal.
AXLE OVERHEATING	<ol style="list-style-type: none"> 1. Lubricant level too low. 2. Incorrect grade of lubricant. 3. Bearings adjusted too tight. 4. Excessive gear wear. 5. Insufficient ring gear backlash. 	<ol style="list-style-type: none"> 1. Refill differential housing. 2. Drain, flush and refill with correct amount of the correct lubricant. 3. Readjust bearings. 4. Inspect gears for excessive wear or scoring. Replace as necessary. 5. Readjust ring gear backlash and inspect gears for possible scoring.
GEAR TEETH BROKE (RING GEAR AND PINION)	<ol style="list-style-type: none"> 1. Overloading. 2. Erratic clutch operation. 3. Ice-spotted pavements. 4. Improper adjustments. 	<ol style="list-style-type: none"> 1. Replace gears. Examine other gears and bearings for possible damage. 2. Replace gears and examine the remaining parts for possible damage. Avoid erratic clutch operation. 3. Replace gears. Examine the remaining parts for possible damage. Replace parts as required. 4. Replace gears. Examine other parts for possible damage. Ensure ring gear backlash is correct.
AXLE NOISE	<ol style="list-style-type: none"> 1. Insufficient lubricant. 2. Improper ring gear and drive pinion gear adjustment. 3. Unmatched ring gear and drive pinion gear. 4. Worn teeth on ring gear or drive pinion gear. 5. Loose drive pinion gear shaft bearings. 6. Loose differential bearings. 7. Misaligned or sprung ring gear. 8. Loose differential bearing cap bolts 	<ol style="list-style-type: none"> 1. Refill axle with correct amount of the proper lubricant. Also inspect for leaks and correct as necessary. 2. Check ring gear and pinion gear teeth contact pattern. 3. Remove unmatched ring gear and drive pinion gear. Replace with matched gear and drive pinion gear set. 4. Check teeth on ring gear and drive pinion gear for correct contact. If necessary, replace with new matched set. 5. Adjust drive pinion gearshaft bearing preload torque. 6. Adjust differential bearing preload torque. 7. Measure ring gear runout. 8. Tighten with specified torque

DIAGNOSIS AND TESTING (Continued)**TRAC-LOK TEST**

WARNING: WHEN SERVICING VEHICLES WITH A TRAC-LOK DIFFERENTIAL DO NOT USE THE ENGINE TO TURN THE AXLE AND WHEELS. BOTH REAR WHEELS MUST BE RAISED AND THE VEHICLE SUPPORTED. A TRAC-LOK AXLE CAN EXERT ENOUGH FORCE IF ONE WHEEL IS IN CONTACT WITH A SURFACE TO CAUSE THE VEHICLE TO MOVE.

The differential can be tested without removing the differential case by measuring rotating torque. Make sure brakes are not dragging during this measurement.

- (1) Place blocks in front and rear of both front wheels.
- (2) Raise one rear wheel until it is completely off the ground.
- (3) Engine off, transmission in neutral, and parking brake off.
- (4) Remove wheel and bolt Special Tool 6790 to studs.
- (5) Use torque wrench on special tool to rotate wheel and read rotating torque (Fig. 5).

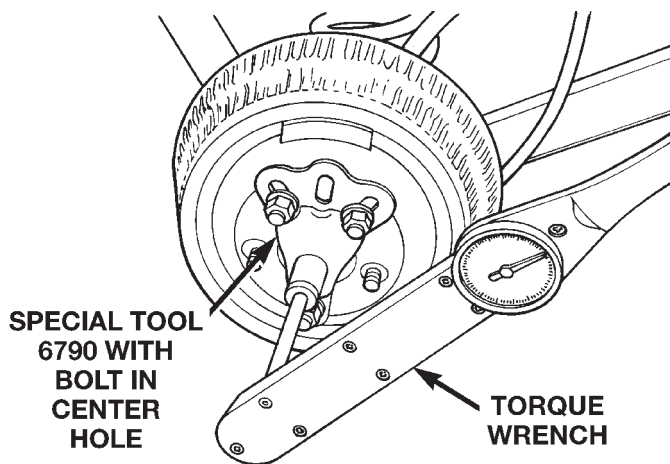


Fig. 5 Trac-lok Test – Typical

- (6) If rotating torque is less than 22 N·m (30 ft. lbs.) or more than 271 N·m (200 ft. lbs.) on either wheel the unit should be serviced.

SERVICE PROCEDURES**LUBRICANT CHANGE**

- (1) Raise and support the vehicle.
- (2) Remove the lubricant fill hole plug from the differential housing cover.
- (3) Remove the differential housing cover and drain the lubricant from the housing.

- (4) Clean the housing cavity with a flushing oil, light engine oil, or lint free cloth. **Do not use water, steam, kerosene, or gasoline for cleaning.**

- (5) Remove the original sealant from the housing and cover surfaces.

- (6) Apply a bead of Mopar® Silicone Rubber Sealant, or equivalent, to the housing cover (Fig. 6).

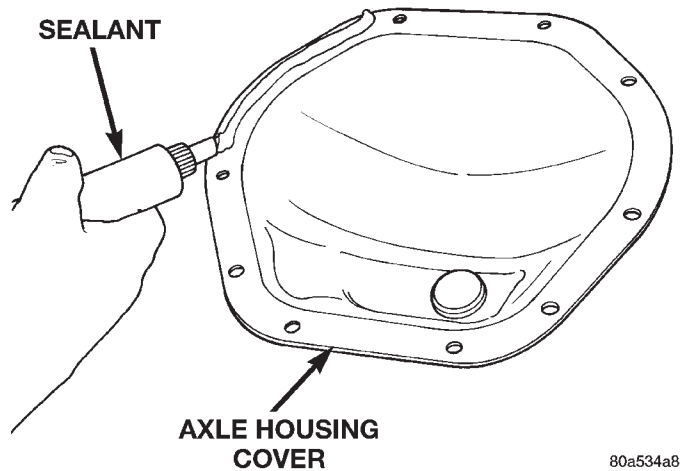


Fig. 6 Apply Sealant

Install the housing cover within 5 minutes after applying the sealant.

- (7) Install the cover and any identification tag. Tighten the cover bolts to 41 N·m (30 ft. lbs.) torque.

- (8) For Trac-lok differentials, a quantity of Mopar® Trac-lok lubricant (friction modifier), or equivalent, must be added after repair service or a lubricant change. Refer to the Lubricant Specifications section of this group for the quantity necessary.

- (9) Fill differential with Mopar® Hypoid Gear Lubricant, or equivalent, to bottom of the fill plug hole. Refer to the Lubricant Specifications section of this group for the quantity necessary.

CAUTION: Overfilling the differential can result in lubricant foaming and overheating.

- (10) Install the fill hole plug and lower the vehicle.

- (11) Trac-lok differential equipped vehicles should be road tested by making 10 to 12 slow figure-eight turns. This maneuver will pump the lubricant through the clutch discs to eliminate a possible chatter noise complaint.

REMOVAL AND INSTALLATION**REAR AXLE****REMOVAL**

- (1) Raise and support the vehicle.

REMOVAL AND INSTALLATION (Continued)

- (2) Position a suitable lifting device under the axle.
- (3) Secure axle to device.
- (4) Remove the wheels and tires.
- (5) Remove the brake rotors and calipers from the axle. Refer to Group 5, Brakes, for proper procedures.
- (6) Disconnect parking brake cables from brackets and lever.
- (7) Remove wheel speed sensors, if necessary. Refer to Group 5, Brakes, for proper procedures.
- (8) Disconnect the brake hose at the axle junction block. Do not disconnect the brake hydraulic lines at the calipers. Refer to Group 5, Brakes, for proper procedures.
- (9) Disconnect the vent hose from the axle shaft tube.
- (10) Mark the propeller shaft and yokes for installation alignment reference.
- (11) Remove propeller shaft.
- (12) Disconnect stabilizer bar links.
- (13) Disconnect shock absorbers from axle.
- (14) Disconnect track bar.
- (15) Disconnect upper and lower suspension arms from the axle brackets.
- (16) Separate the axle from the vehicle.

INSTALLATION

NOTE: The weight of the vehicle must be supported by the springs before suspension arms and track bar fasteners can be tightened. If the springs are not at their normal ride position, vehicle ride height and handling could be affected.

- (1) Raise the axle with lifting device and align coil springs.
- (2) Position the upper and lower suspension arms on the axle brackets. Install nuts and bolts, do not tighten bolts at this time.
- (3) Install track bar and attachment bolts, do not tighten bolts at this time.
- (4) Install shock absorbers and tighten nuts to 60 N·m (44 ft. lbs.) torque.
- (5) Install stabilizer bar links and tighten nuts to 36 N·m (27 ft. lbs.) torque.
- (6) Install the wheel speed sensors, if necessary. Refer to Group 5, Brakes, for proper procedures.
- (7) Connect parking brake cable to brackets and lever.
- (8) Install the brake rotors and calipers. Refer to Group 5, Brakes, for proper procedures.
- (9) Connect the brake hose to the axle junction block. Refer to Group 5, Brakes, for proper procedures.
- (10) Install axle vent hose.

- (11) Align propeller shaft and pinion yoke reference marks. Install U-joint straps and bolts. Tighten to 19 N·m (14 ft. lbs.) torque.
- (12) Install the wheels and tires.
- (13) Add gear lubricant, if necessary. Refer to Lubricant Specifications in this section for lubricant requirements.
- (14) Remove lifting device from axle and lower the vehicle.
- (15) Tighten lower suspension arm bolts to 177 N·m (130 ft. lbs.) torque.
- (16) Tighten upper suspension arm bolts to 75 N·m (55 ft. lbs.) torque.
- (17) Tighten track bar bolts to 100 N·m (74 ft. lbs.) torque.

PINION SHAFT SEAL**REMOVAL**

- (1) Raise and support the vehicle.
- (2) Remove wheel and tire assemblies.
- (3) Remove rear brake rotors and calipers. Refer to Group 5, Brakes, for proper procedures.
- (4) Mark the propeller shaft and pinion yoke for installation reference.
- (5) Remove the propeller shaft from the yoke.
- (6) Rotate the pinion gear three or four times.
- (7) Measure the amount of torque necessary to rotate the pinion gear with a (in. lbs.) dial-type torque wrench. Record the torque reading for installation reference.
- (8) Using a short piece of pipe and Holder 6958 to hold the pinion yoke, remove the pinion nut and washer (Fig. 7).
- (9) Use Remover C-452 and Wrench C-3281 to remove the pinion yoke (Fig. 8)
- (10) Use Remover 7794-A and slide hammer to remove the pinion shaft seal (Fig. 9)..

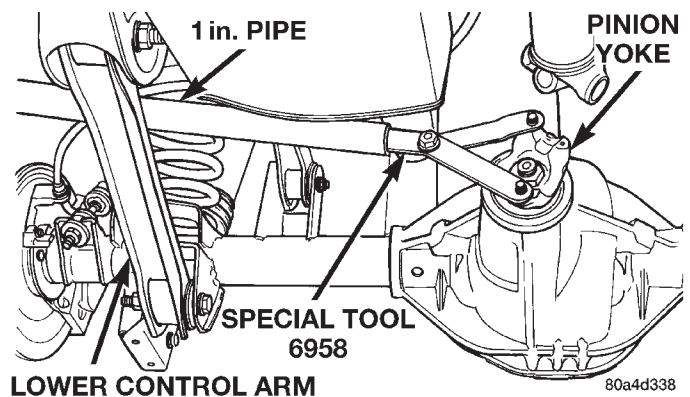


Fig. 7 Pinion Yoke Holder

REMOVAL AND INSTALLATION (Continued)

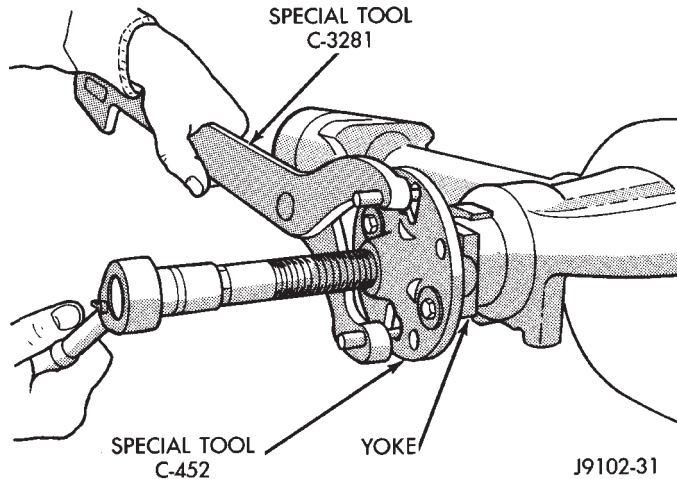


Fig. 8 Pinion Yoke Removal

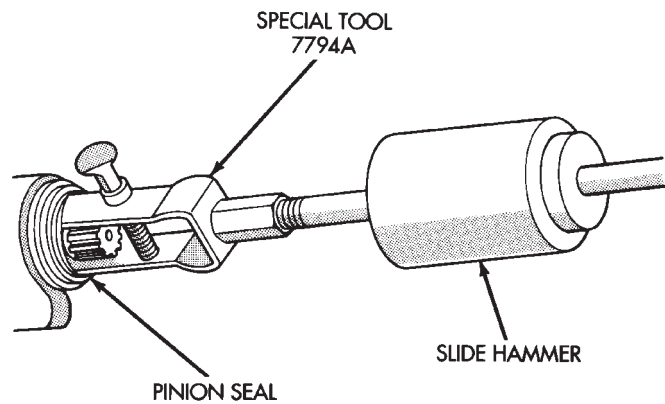


Fig. 9 Seal Removal

INSTALLATION

(1) Apply a light coating of gear lubricant on the lip of pinion seal. Install seal with Installer C-3972-A and Handle C-4171 (Fig. 10).

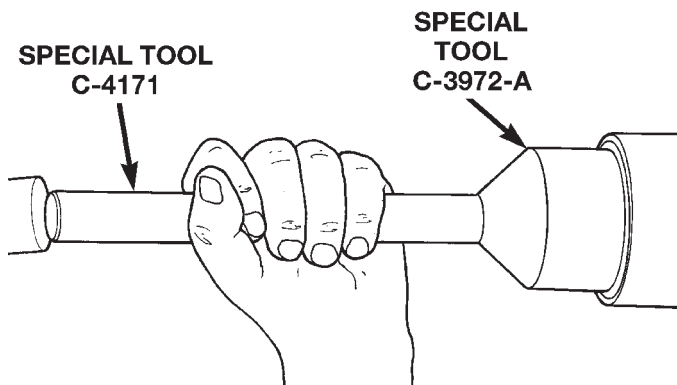


Fig. 10 Pinion Seal Installation

(2) Install yoke on the pinion gear with Installer C-3718 and Holder 6958 (Fig. 11).

CAUTION: Do not exceed the minimum tightening torque when installing the pinion yoke retaining nut at this point. Damage to collapsible spacer or bearings may result.

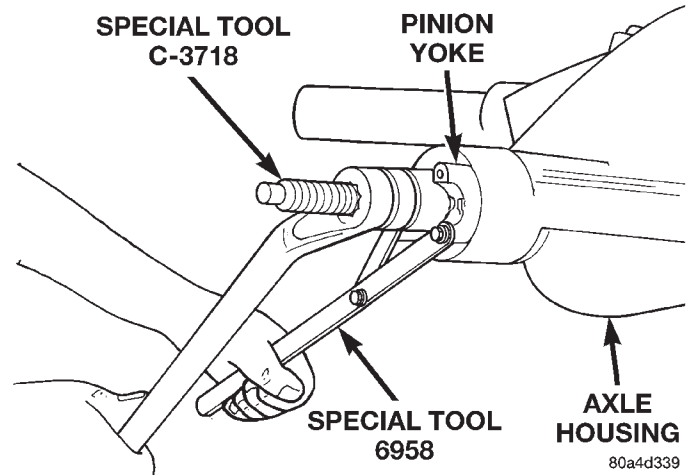


Fig. 11 Pinion Yoke Installation

(3) Install a new nut on the pinion gear. **Tighten the nut only enough to remove the shaft end play.**

(4) Rotate the pinion shaft using a (in. lbs.) torque wrench. Rotating resistance torque should be equal to the reading recorded during removal, plus an additional 0.56 N-m (5 in. lbs.) (Fig. 12).

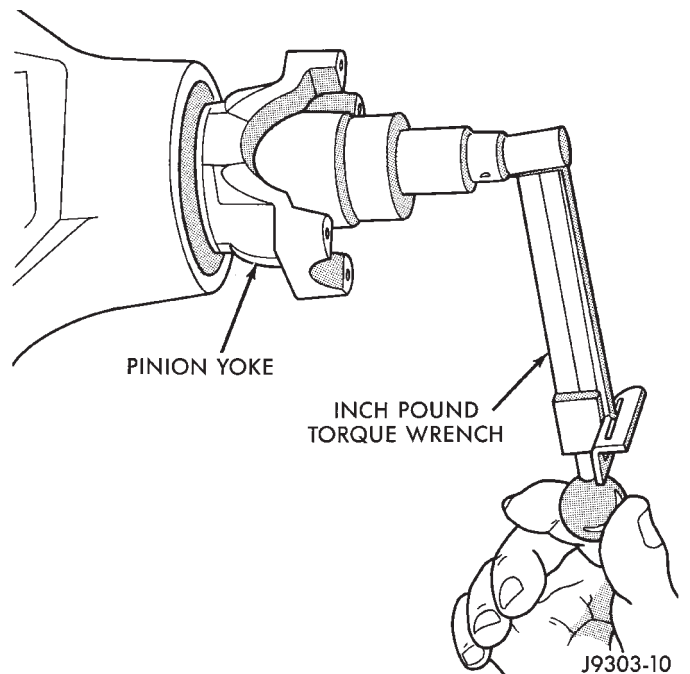


Fig. 12 Check Pinion Rotation Torque

REMOVAL AND INSTALLATION (Continued)

(5) If the rotating torque is low, use Holder 6958 to hold the pinion yoke (Fig. 13), and tighten the pinion shaft nut in 6.8 N-m (5 ft. lbs.) increments until proper rotating torque is achieved.

CAUTION: If the maximum tightening torque is reached prior to reaching the required rotating torque, the collapsible spacer may have been damaged. Replace the collapsible spacer.

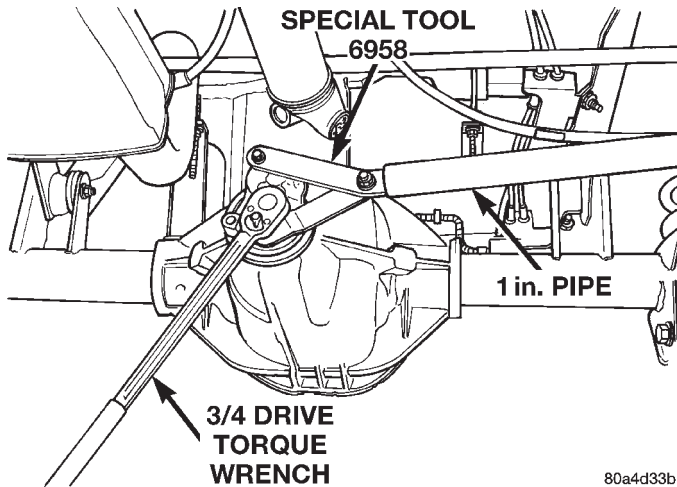


Fig. 13 Tightening Pinion Shaft Nut

- (6) Align the installation reference marks on propeller shaft and yoke and install the propeller shaft.
- (7) Add gear lubricant to the differential housing, if necessary. Refer to the Lubricant Specifications for gear lubricant requirements.
- (8) Install brake rotors and calipers. Refer to Group 5, Brakes, for proper procedures.
- (9) Install wheel and tire assemblies.
- (10) Lower the vehicle.

COLLAPSIBLE SPACER

REMOVAL W/PINION INSTALLED

- (1) Raise and support the vehicle.
- (2) Remove wheel and tire assemblies.
- (3) Remove rear brake rotors and calipers. Refer to Group 5, Brakes, for proper procedures.
- (4) Mark the propeller shaft and pinion yoke for installation reference.
- (5) Remove the propeller shaft from the yoke.
- (6) Rotate the pinion gear three or four times.
- (7) Measure the amount of torque necessary to rotate the pinion gear with a (in. lbs.) dial-type torque wrench. Record the torque reading for installation reference.
- (8) Using a short piece of pipe and Holder 6958 to hold the pinion yoke, remove the pinion nut and washer (Fig. 14).
- (9) Use Remover C-452 and Wrench C-3281 to remove the pinion yoke (Fig. 15).

(10) Use Remover 7794-A and slide hammer to remove the pinion shaft seal (Fig. 16).

(11) Remove the front pinion bearing using a pair of suitable pick tools to pull the bearing straight off the pinion gear shaft. It may be necessary to lightly tap the end of the pinion gear with a rawhide or rubber mallet if the bearing becomes bound on the pinion shaft.

(12) Remove the collapsible spacer.

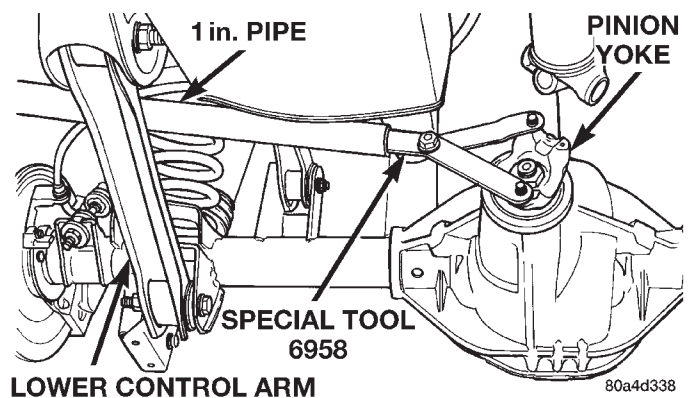


Fig. 14 Pinion Yoke Holder

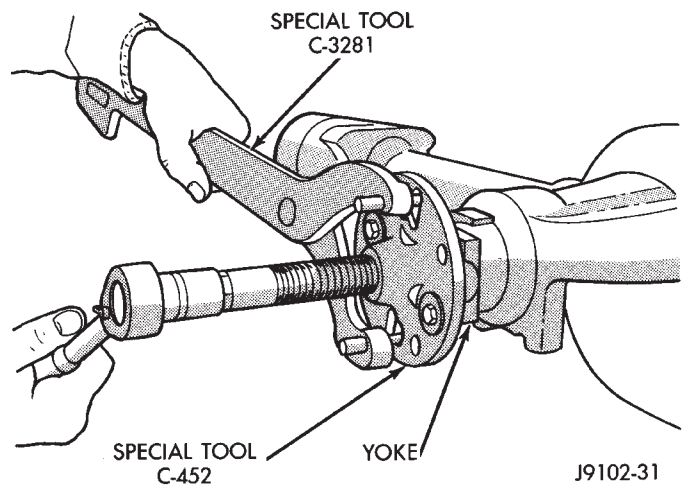
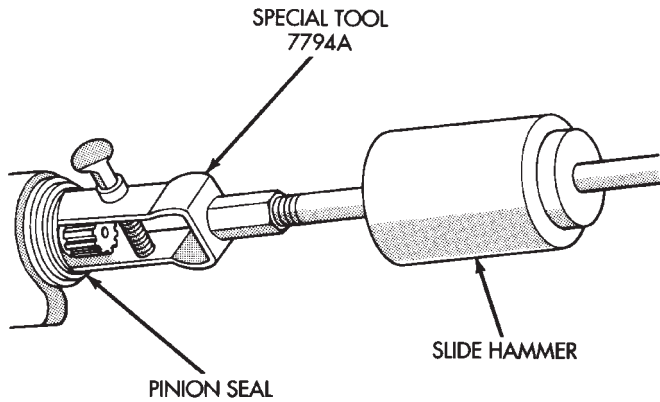


Fig. 15 Pinion Yoke Removal

REMOVAL W/PINION REMOVED

- (1) Raise and support the vehicle.
- (2) Remove wheel and tire assemblies.
- (3) Remove rear brake rotors and calipers. Refer to Group 5, Brakes, for proper procedures.
- (4) Mark the propeller shaft and pinion yoke for installation reference.
- (5) Remove the propeller shaft from the yoke.
- (6) Rotate the pinion gear three or four times.
- (7) Measure the amount of torque necessary to rotate the pinion gear with a (in. lbs.) dial-type torque wrench. Record the torque reading for installation reference.
- (8) Remove differential assembly from axle housing.

REMOVAL AND INSTALLATION (Continued)



J9402-59X

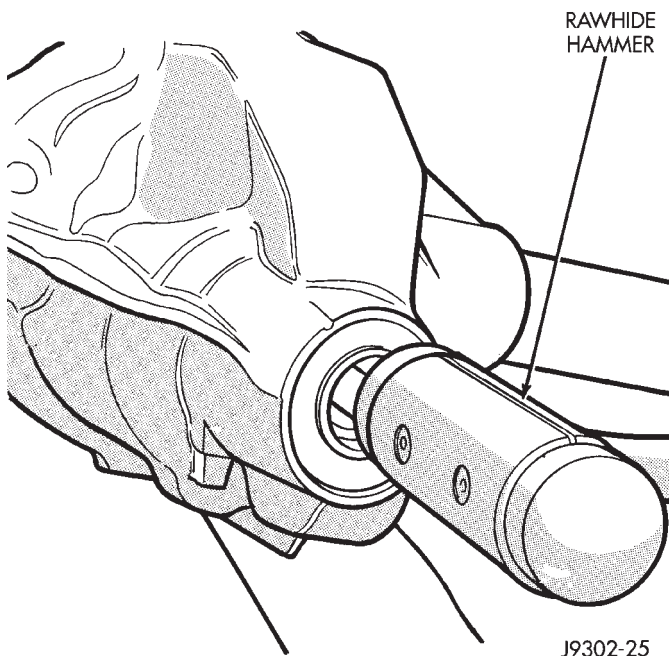
Fig. 16 Seal Removal

(9) Using Holder 6958 to hold yoke and a short length of 1 in. pipe, remove the pinion yoke nut and washer (Fig. 14).

(10) Using Remover C-452 and Wrench C-3281, remove the pinion yoke from pinion shaft (Fig. 15).

(11) Remove the pinion gear from housing (Fig. 17). Catch the pinion with your hand to prevent it from falling and being damaged.

(12) Remove collapsible spacer from pinion shaft.



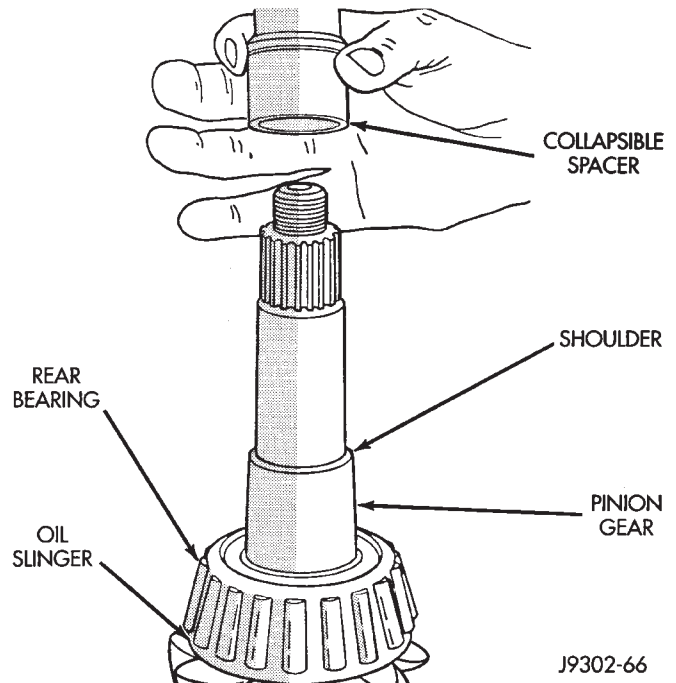
J9302-25

Fig. 17 Remove Pinion Gear**INSTALLATION**

(1) Install a new collapsible preload spacer on pinion shaft (Fig. 18).

(2) If pinion gear was removed, install pinion gear in housing.

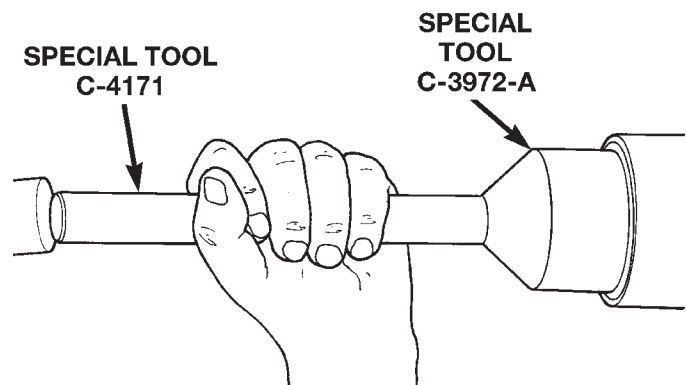
(3) Install pinion front bearing, if necessary.



J9302-66

Fig. 18 Collapsible Preload Spacer

(4) Apply a light coating of gear lubricant on the lip of pinion seal. Install seal with Installer C-3972-A and Handle C-4171 (Fig. 19).



80a7e2be

Fig. 19 Pinion Seal Installation

(5) Install yoke with Installer C-3718 and Holder 6958 (Fig. 20).

(6) If the original pinion bearings are being used, install differential assembly and axle shafts, if necessary.

NOTE: If new pinion bearings were installed, do not install the differential assembly and axle shafts until after the pinion bearing preload and rotating torque are set.

REMOVAL AND INSTALLATION (Continued)

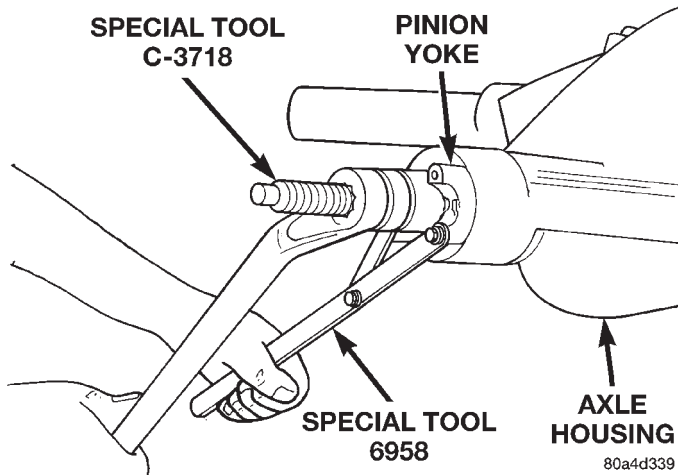


Fig. 20 Pinion Yoke Installation

(7) Install the yoke washer and a new nut on the pinion gear. Tighten the nut to 298 N·m (220 ft. lbs.) minimum. **Do not over-tighten.** Maximum torque is 380 N·m (280 ft. lbs.).

CAUTION: Never loosen pinion gear nut to decrease pinion gear bearing rotating torque and never exceed specified preload torque. If preload torque is exceeded a new collapsible spacer must be installed. The torque sequence will then have to be repeated.

NOTE: If the spacer requires more than 280 ft. lbs. torque to crush, the collapsible spacer is defective.

(8) Using yoke holder 6958, a short length of 1 in. pipe, and a torque wrench set at 380 N·m (280 ft. lbs.), crush collapsible spacer until bearing end play is taken up (Fig. 21).

(9) Slowly tighten the nut in 6.8 N·m (5 ft. lbs.) increments until the rotating torque is achieved. Measure the rotating torque frequently to avoid over crushing the collapsible spacer (Fig. 22).

(10) Check rotating torque with an inch pound torque wrench (Fig. 22). The torque necessary to rotate the pinion gear should be:

- Original Bearings — The reading recorded during removal, plus an additional 0.56 N·m (5 in. lbs.).
- New Bearings — 2 to 5 N·m (15 to 35 in. lbs.).

(11) Install differential assembly and axle shafts, if necessary.

(12) Align marks made previously on yoke and propeller shaft and install propeller shaft.

(13) Install rear brake rotors and calipers. Refer to Group 5 Brakes, for proper procedures.

(14) Add gear lubricant, if necessary. Refer to Lubricant Specifications of this section for lubricant requirements.

(15) Install wheel and tire assemblies.

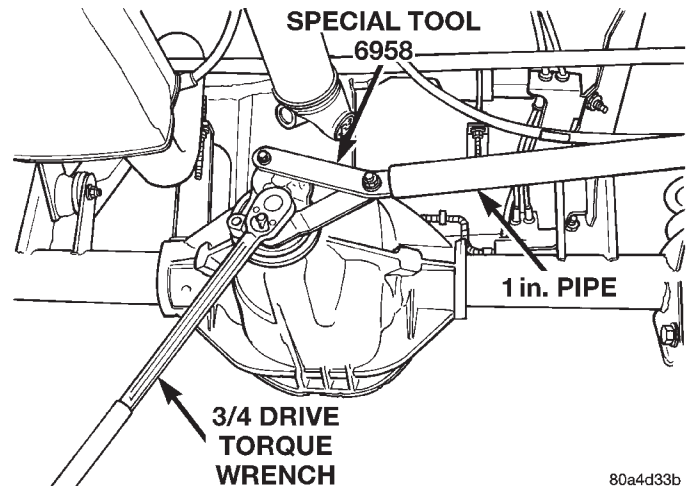


Fig. 21 Tightening Pinion Nut

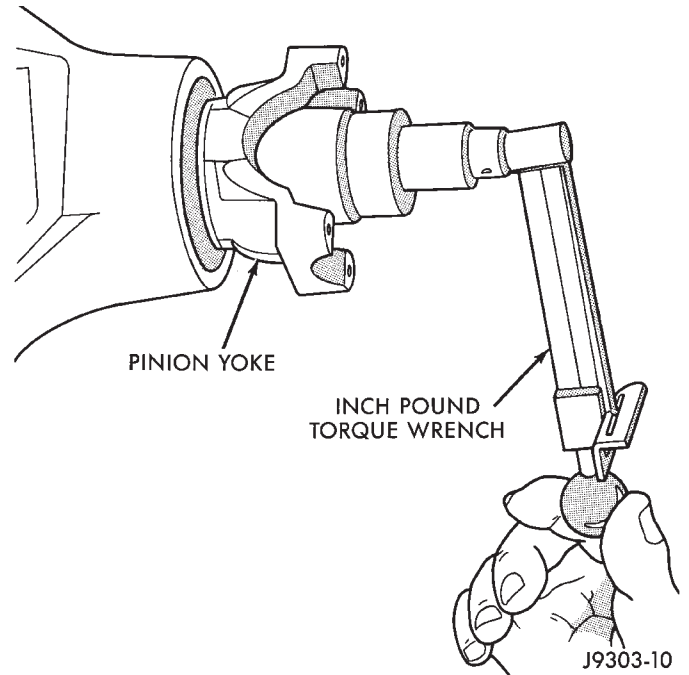


Fig. 22 Check Pinion Gear Rotation Torque

(16) Lower vehicle.

AXLE SHAFT

REMOVAL

(1) Raise and support vehicle. Ensure that the transmission is in neutral.

(2) Remove wheel and tire assembly.

(3) Remove brake caliper and rotor. Refer to Group 5, Brakes, for proper procedure.

(4) Clean all foreign material from housing cover area.

(5) Loosen housing cover bolts. Drain lubricant from the housing and axle shaft tubes. Remove housing cover.

REMOVAL AND INSTALLATION (Continued)

(6) Rotate differential case so that pinion mate gear shaft lock screw is accessible. Remove lock screw and pinion mate gear shaft from differential case (Fig. 23).

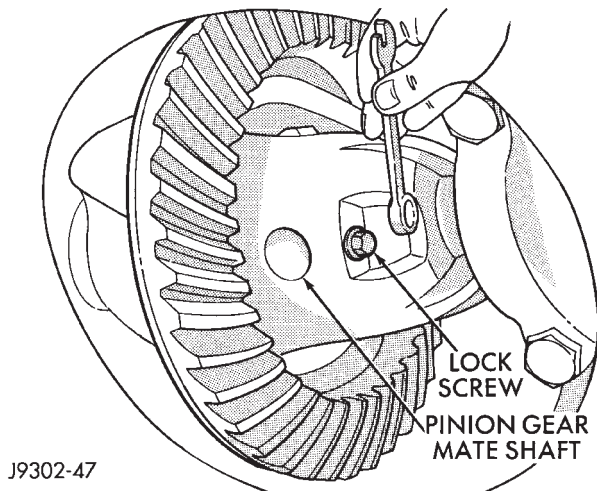


Fig. 23 Mate Shaft Lock Screw

(7) Push axle shaft inward and remove axle shaft C-clip lock from the axle shaft (Fig. 24).

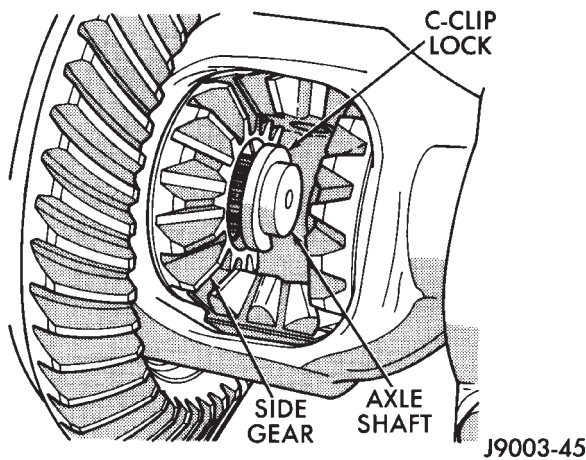


Fig. 24 Axle Shaft C-Clip Lock

(8) Remove axle shaft. Use care to prevent damage to axle shaft bearing and seal, which will remain in axle shaft tube. Also, exercise care not to damage the wheel speed sensor on vehicles equipped with ABS brakes.

(9) Inspect axle shaft seal for leakage or damage.

(10) Inspect roller bearing contact surface on axle shaft for signs of brinelling, galling and pitting. If any of these conditions exist, the axle shaft and/or bearing and seal must be replaced.

INSTALLATION

(1) Lubricate bearing bore and seal lip with gear lubricant. Insert axle shaft through seal, bearing, and engage it into side gear splines.

NOTE: Use care to prevent shaft splines from damaging axle shaft seal lip. Also, exercise care not to damage the wheel speed sensor on vehicles equipped with ABS brakes

(2) Insert C-clip lock in end of axle shaft. Push axle shaft outward to seat C-clip lock in side gear.

(3) Insert pinion mate shaft into differential case and through thrust washers and pinion gears.

(4) Align hole in shaft with hole in the differential case and install lock screw with Loctite® on the threads. Tighten lock screw to 19 N·m (14 ft. lbs.) torque.

(5) Install cover and add fluid. Refer to Lubricant Change procedure in this section for procedure and lubricant requirements.

(6) Install brake caliper and rotor. Refer to Group 5, Brakes, for proper procedures.

(7) Install wheel and tire.

(8) Lower vehicle.

AXLE SHAFT SEAL AND BEARING**REMOVAL**

(1) Remove the axle shaft.

(2) Remove the axle shaft seal from the end of the axle shaft tube with a small pry bar.

NOTE: The seal and bearing can be removed at the same time with the bearing removal tool.

(3) Remove the axle shaft bearing from the tube (Fig. 25) with Bearing Removal Tool Set 6310 using Adapter Foot 6310-5.

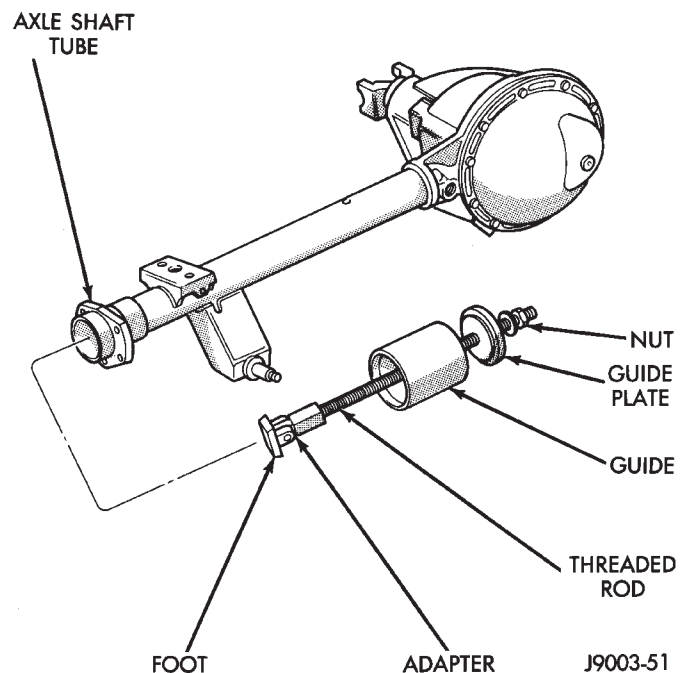


Fig. 25 Axle Shaft Bearing Removal Tool

REMOVAL AND INSTALLATION (Continued)

(4) Inspect the axle shaft tube bore for roughness and burrs. Remove as necessary.

INSTALLATION

Do not install the original axle shaft seal. Always install a new seal.

- (1) Wipe the bore in the axle shaft tube clean.
- (2) Install axle shaft bearing with Installer 6436 and Handle C-4171. Ensure part number on the bearing is against the installer.
- (3) Install the new axle shaft seal (Fig. 26) with Installer 6437 and Handle C-4171.
- (4) Install the axle shaft.

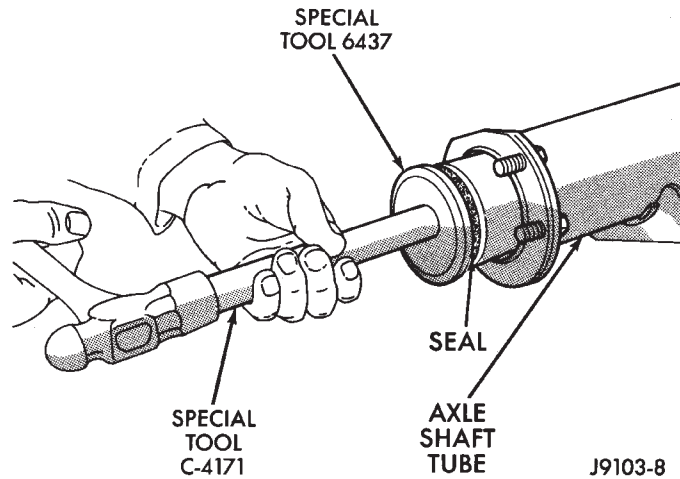


Fig. 26 Axle Shaft Seal Installation

DIFFERENTIAL

REMOVAL

- (1) Remove axle shafts.
- (2) Note the orientation of the installation reference letters stamped on the bearing caps and housing machined sealing surface (Fig. 27).

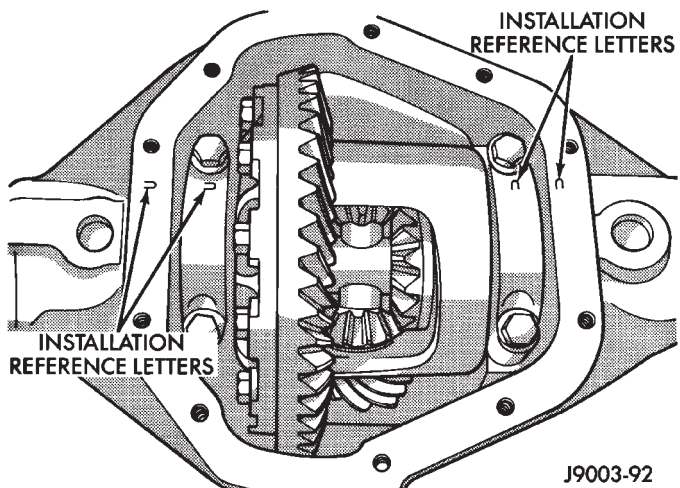


Fig. 27 Bearing Cap Identification

- (3) Remove the differential bearing caps.
- (4) Position Spreader W-129-B with the tool dowel pins seated in the locating holes (Fig. 28).
- (5) Install the hold down clamps and tighten the tool turnbuckle finger-tight.

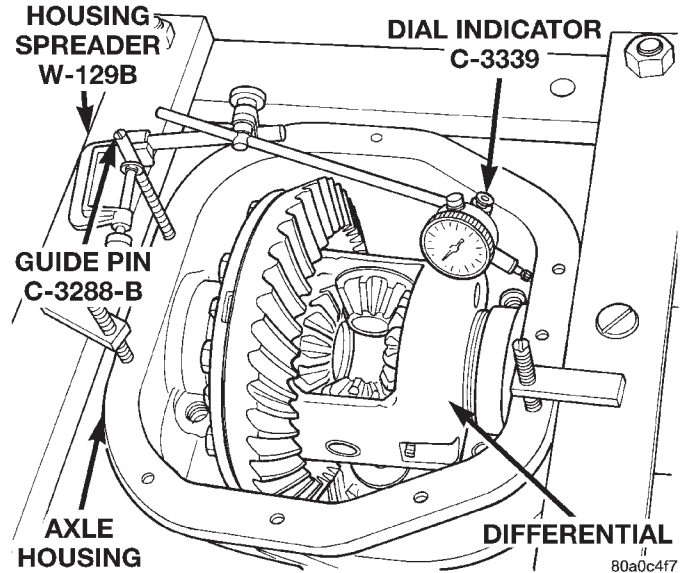


Fig. 28 Spread Differential Housing

(6) Install a Guide Pin C-3288-B at the left side of the differential housing. Attach dial indicator to housing pilot stud. Load the indicator plunger against the opposite side of the housing (Fig. 28) and zero the indicator.

(7) Spread the housing enough to remove the case from the housing. Measure the distance with the dial indicator (Fig. 28).

CAUTION: Do not spread over 0.50 mm (0.020 in). If the housing is over-spread, it could be distorted or damaged.

REMOVAL AND INSTALLATION (Continued)

(8) Remove the dial indicator.

(9) Pry the differential case loose from the housing. To prevent damage, pivot on housing with the end of the pry bar against spreader (Fig. 29).

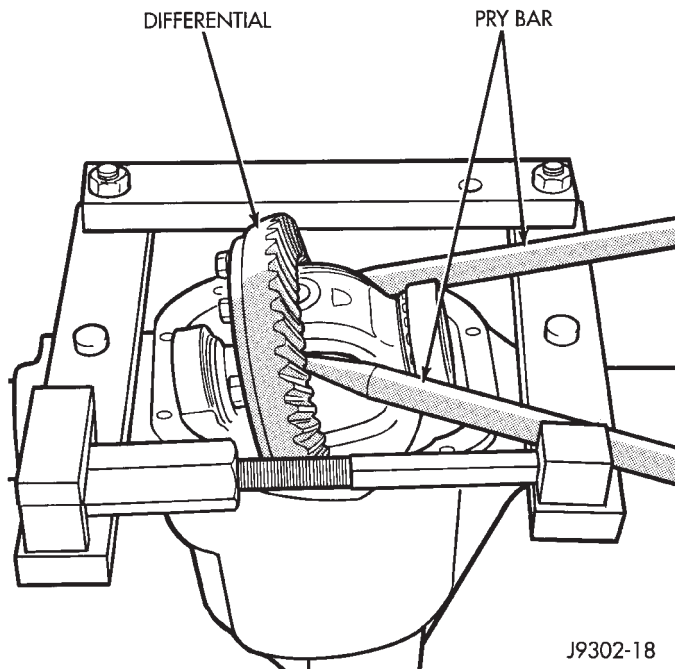


Fig. 29 Differential Removal

(10) Remove the case from housing. Mark or tag bearing cups and outboard shim(s)/spacer(s) (selected thickness) to indicate which side they were removed from.

INSTALLATION

(1) Position Spreader W-129-B with the tool dowel pins seated in the locating holes (Fig. 28). Install the hold down clamps and tighten the tool turnbuckle finger-tight.

(2) Install a Guide Pin C-3288-B at the left side of the differential housing. Attach dial indicator to housing pilot stud. Load the indicator plunger against the opposite side of the housing (Fig. 28) and zero the indicator.

(3) Spread the housing enough to install the case in the housing. Measure the distance with the dial indicator (Fig. 28).

CAUTION: Do not spread over 0.50 mm (0.020 in). If the housing is over-spread, it could be distorted or damaged.

(4) Remove the dial indicator.

(5) Install differential and outboard shim(s)/spacer(s) (selected thickness) in housing.

(6) Install case in the housing. Tap the differential case with a rawhide or rubber mallet to ensure the bearings are fully seated in the differential housing (Fig. 30).

(7) Remove the spreader.

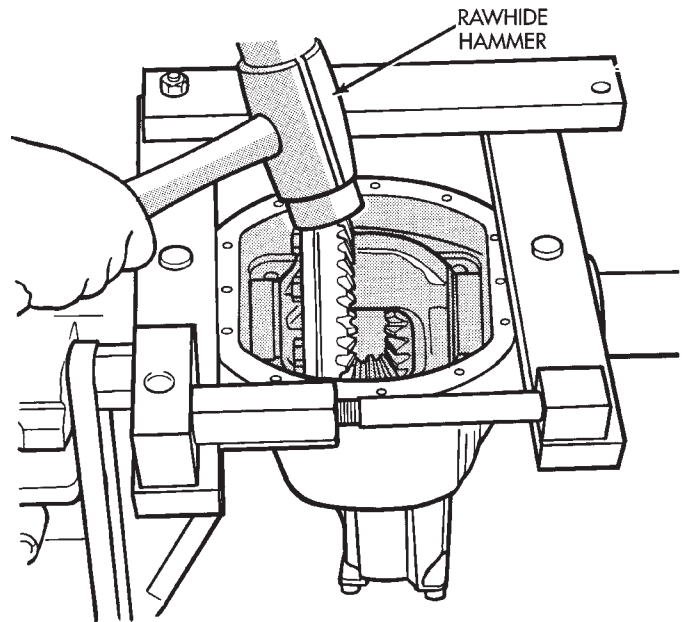


Fig. 30 Differential Installation

(8) Install the bearing caps at their original locations (Fig. 31). Tighten the bearing cap bolts to 77 N·m (57 ft. lbs.) torque.

(9) Install axle shafts.

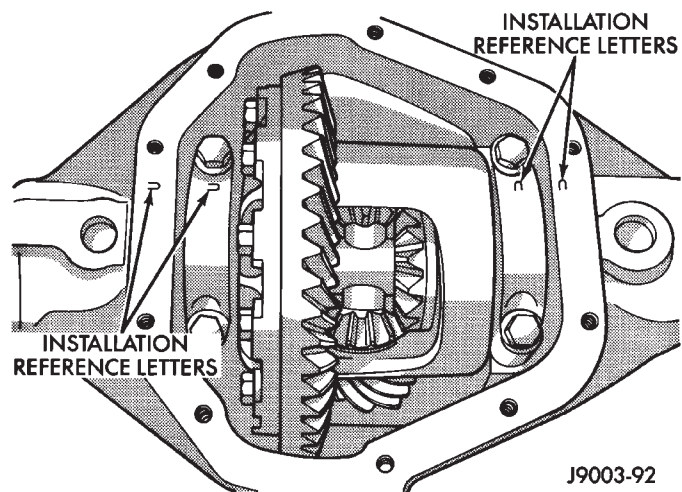


Fig. 31 Differential Bearing Cap Reference Letters

REMOVAL AND INSTALLATION (Continued)

DIFFERENTIAL SIDE BEARINGS

REMOVAL

- (1) Remove differential case from axle housing.
- (2) Remove the bearings from the differential case with Puller/Press C-293-PA, Adapters C-293-42, and Plug C-293-3 (Fig. 32).

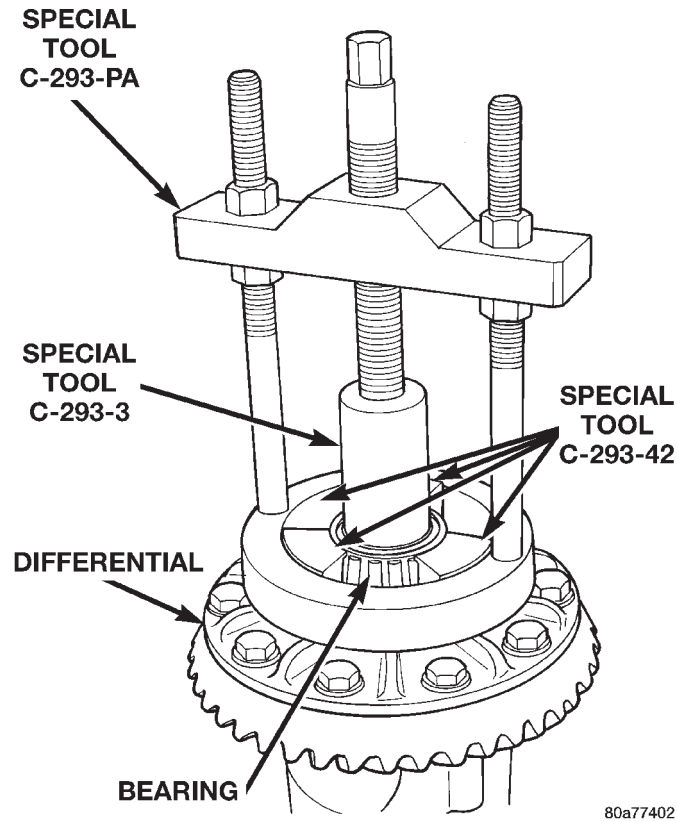


Fig. 32 Differential Bearing Removal

INSTALLATION

- (1) Using tool C-4340 with handle C-4171, install differential side bearings (Fig. 33).
- (2) Install differential case in axle housing.

RING GEAR

The ring and pinion gears are service in a matched set. Do not replace the ring gear without replacing the pinion gear.

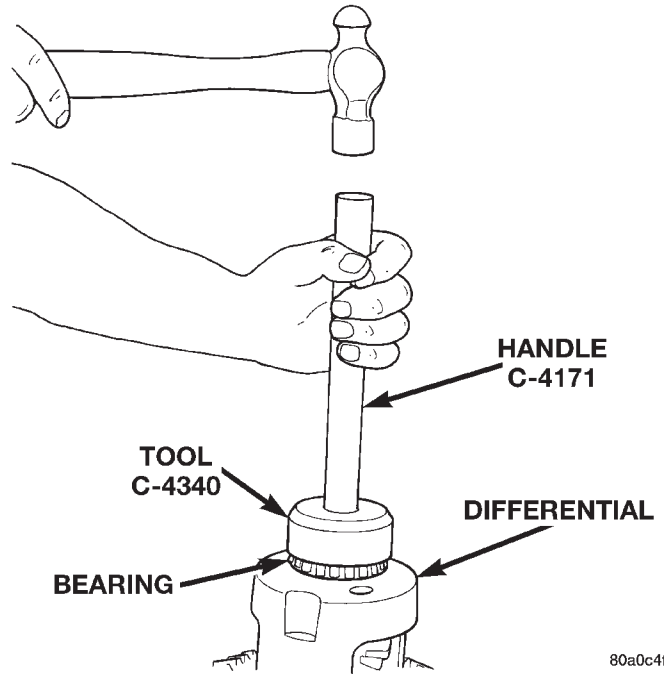


Fig. 33 Install Differential Side Bearings

REMOVAL

- (1) Remove differential from axle housing.
- (2) Place differential case in a suitable vise with soft metal jaw protectors. (Fig. 34)
- (3) Remove bolts holding ring gear to differential case.
- (4) Using a soft hammer, drive ring gear from differential case (Fig. 34).

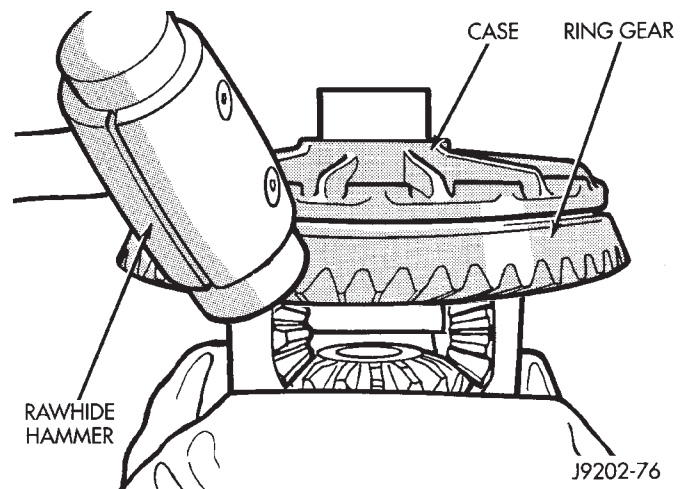


Fig. 34 Ring Gear Removal

REMOVAL AND INSTALLATION (Continued)

INSTALLATION

CAUTION: Do not reuse the bolts that held the ring gear to the differential case. The bolts can fracture causing extensive damage.

- (1) Invert the differential case and start two ring gear bolts. This will provide case-to-ring gear bolt hole alignment.
- (2) Invert the differential case in the vise.
- (3) Install new ring gear bolts and alternately tighten to 95–122 N·m (70–90 ft. lbs.) torque (Fig. 35).
- (4) Install differential in axle housing and verify gear mesh and contact pattern.

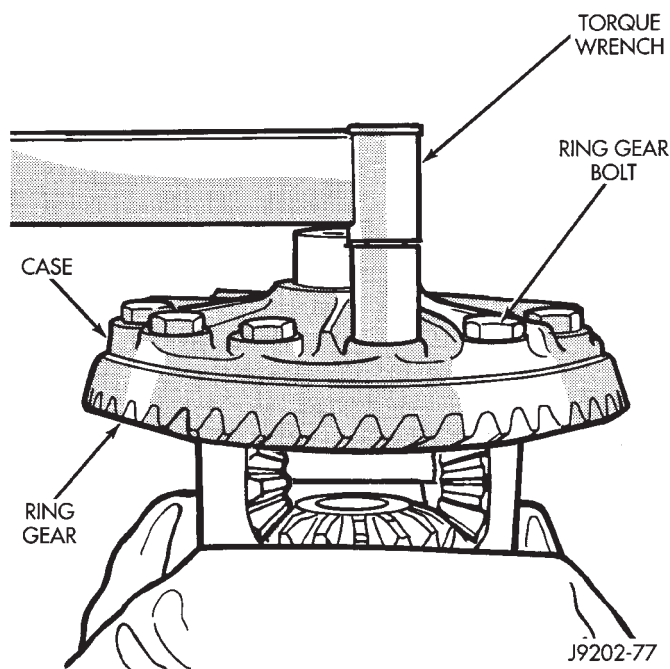


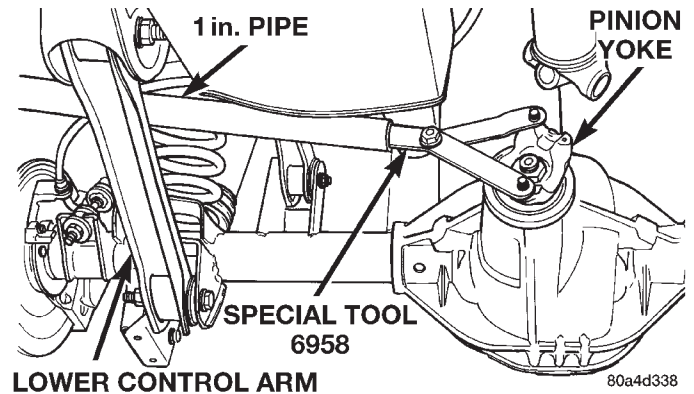
Fig. 35 Ring Gear Bolt Installation

PINION GEAR

NOTE: The ring and pinion gears are service in a matched set. Do not replace the pinion gear without replacing the ring gear.

REMOVAL

- (1) Remove differential assembly from axle housing.
- (2) Mark pinion yoke and propeller shaft for installation alignment.
- (3) Disconnect propeller shaft from pinion yoke. Using suitable wire, tie propeller shaft to underbody.
- (4) Using Holder 6958 to hold yoke and a short length of 1 in. pipe, remove the pinion yoke nut and washer (Fig. 36).
- (5) Using Remover C-452 and Wrench C-3281, remove the pinion yoke from pinion shaft (Fig. 37).



LOWER CONTROL ARM

Fig. 36 Pinion Yoke Holder

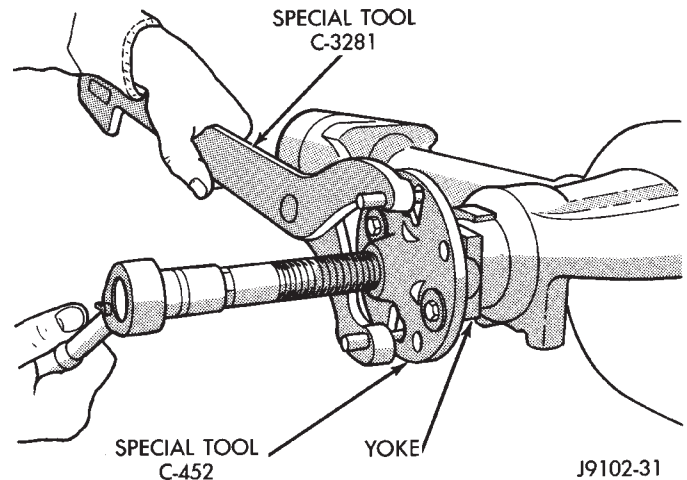


Fig. 37 Pinion Yoke Removal

- (6) Remove the pinion gear from housing (Fig. 38). Catch the pinion with your hand to prevent it from falling and being damaged.

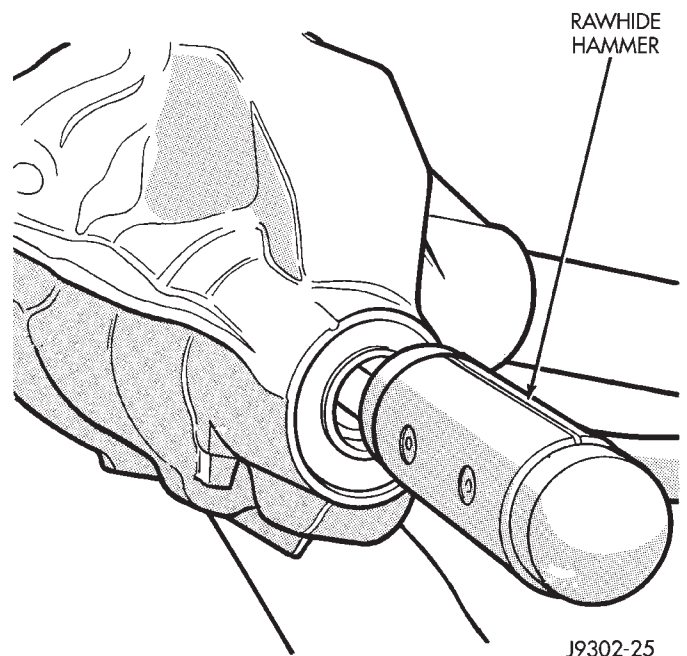


Fig. 38 Remove Pinion Gear

REMOVAL AND INSTALLATION (Continued)

(7) Remove the pinion seal with a slide hammer or pry out with bar.

(8) Remove oil slinger, if equipped, and the front pinion bearing.

(9) Remove the front pinion bearing cup with Remover D-103 and Handle C-4171 (Fig. 39).

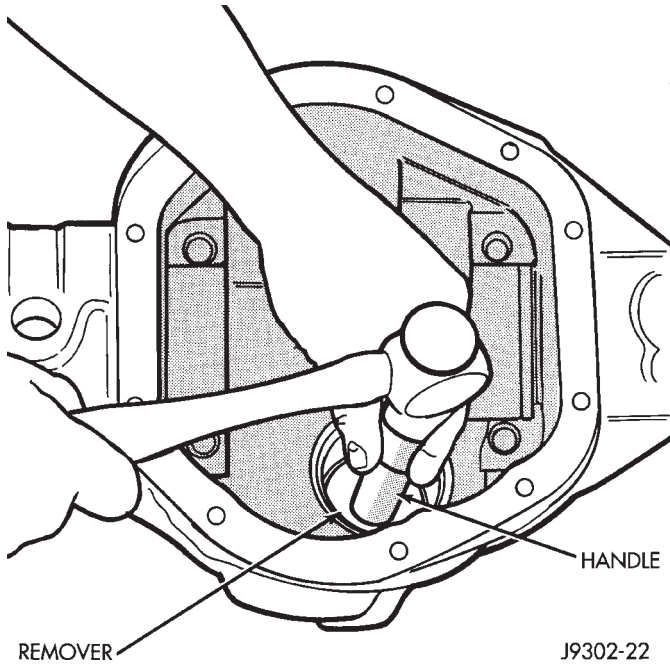


Fig. 39 Front Bearing Cup Removal

(10) Remove the rear bearing cup from housing (Fig. 40). Use Remover C-4307 and Handle C-4171.

(11) Remove the collapsible preload spacer (Fig. 41).

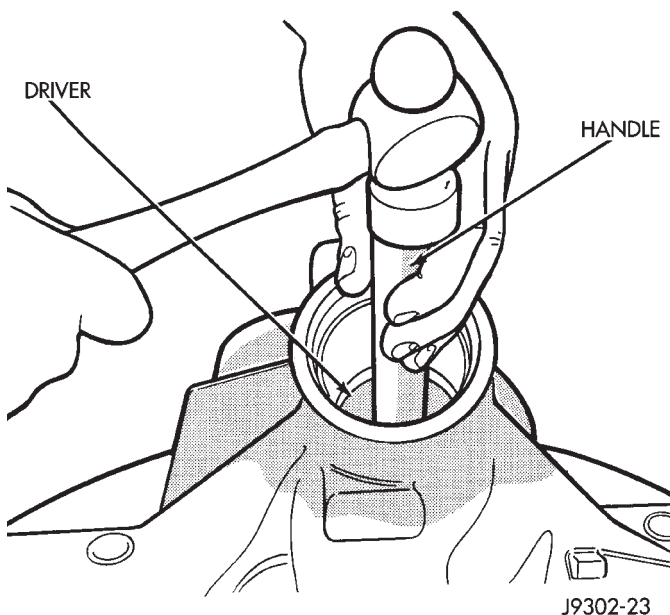


Fig. 40 Rear Bearing Cup Removal

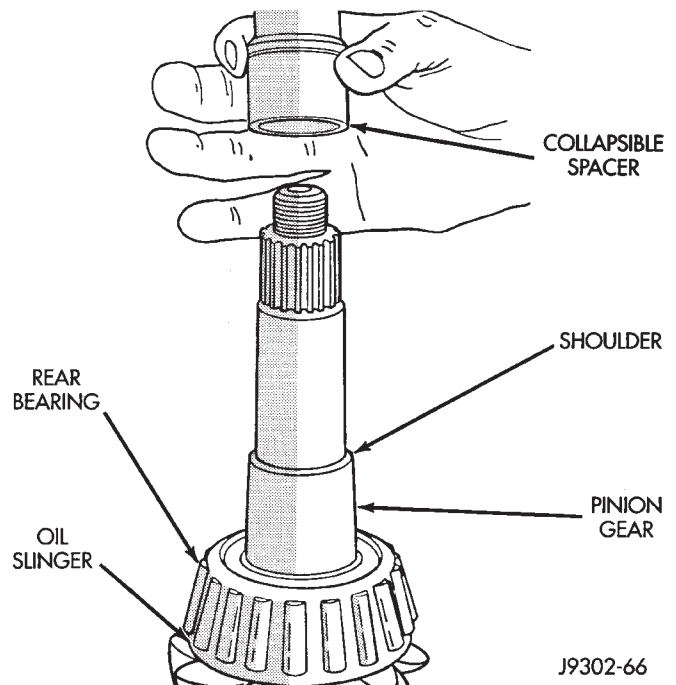


Fig. 41 Collapsible Spacer

(12) Remove the rear bearing from the pinion with Puller/Press C-293-PA and Adapters C-293-42 (Fig. 42).

Place 4 adapter blocks so they do not damage the bearing cage.

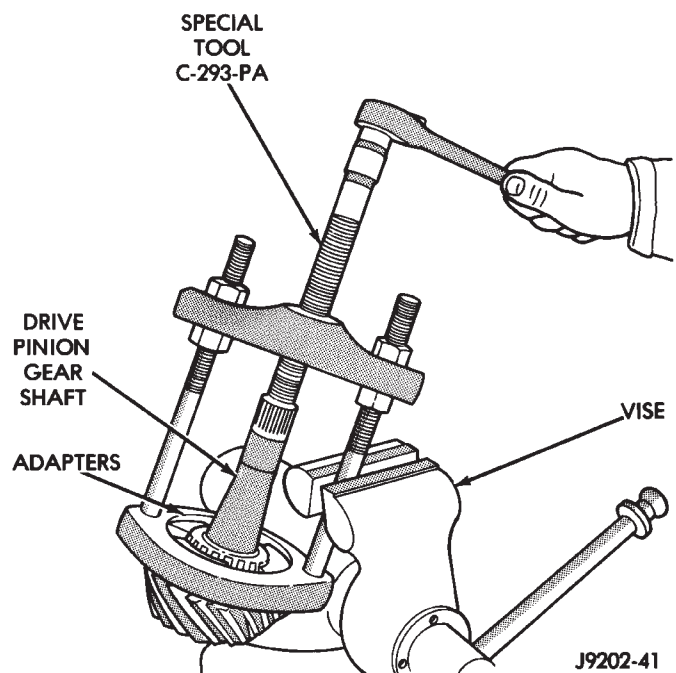


Fig. 42 Inner Bearing Removal

(13) Remove the pinion depth shims from the pinion gear shaft. Record the total thickness of the depth shims.

REMOVAL AND INSTALLATION (Continued)

INSTALLATION

(1) Apply Mopar® Door Ease stick lubricant to outside surface of bearing cup. Install the pinion rear bearing cup with Installer C-4308 and Driver Handle C-4171 (Fig. 43). Ensure cup is correctly seated.

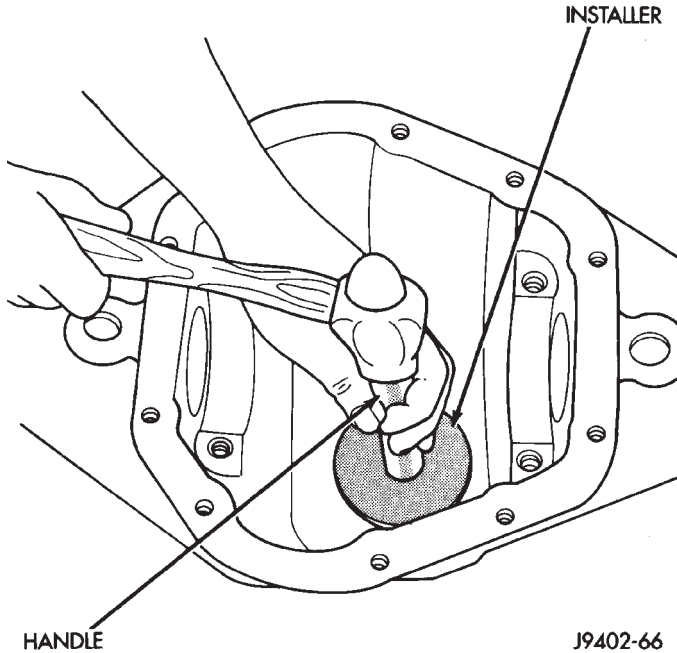


Fig. 43 Pinion Rear Bearing Cup Installation

(2) Apply Mopar® Door Ease stick lubricant to outside surface of bearing cup. Install the pinion front bearing cup with Installer D-129 and Handle C-4171 (Fig. 44).

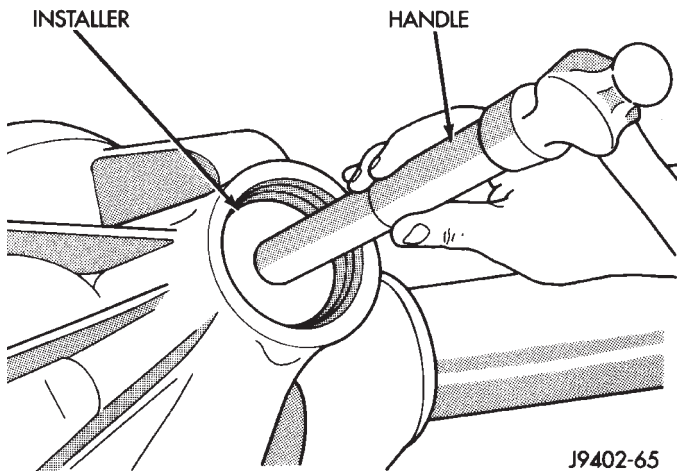


Fig. 44 Pinion Front Bearing Cup Installation

(3) Install pinion front bearing and oil slinger, if equipped. Apply a light coating of gear lubricant on the lip of pinion seal. Install seal with Installer C-3972-A and Handle C-4171 (Fig. 45).

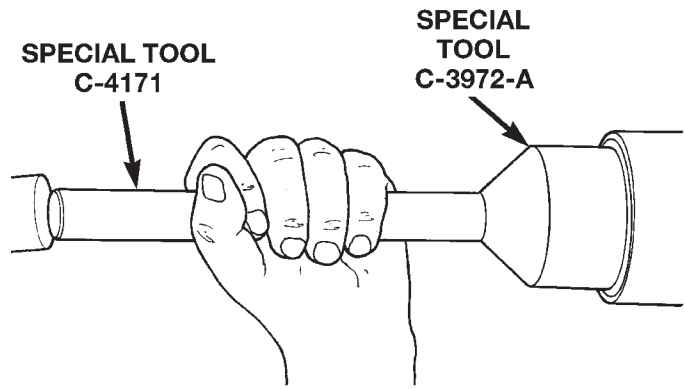


Fig. 45 Pinion Seal Installation

NOTE: Pinion depth shims are placed between the rear pinion bearing cone and pinion gear to achieve proper ring and pinion gear mesh. If the factory installed ring and pinion gears are reused, the pinion depth shim should not require replacement or adjustment. Refer to Pinion Gear Depth paragraph in this section to select the proper thickness shim before installing rear pinion bearing cone.

(4) Place the proper thickness pinion depth shim on the pinion gear.

(5) Install the rear bearing (and slinger if used) on the pinion gear with Installer 6448 (Fig. 46).

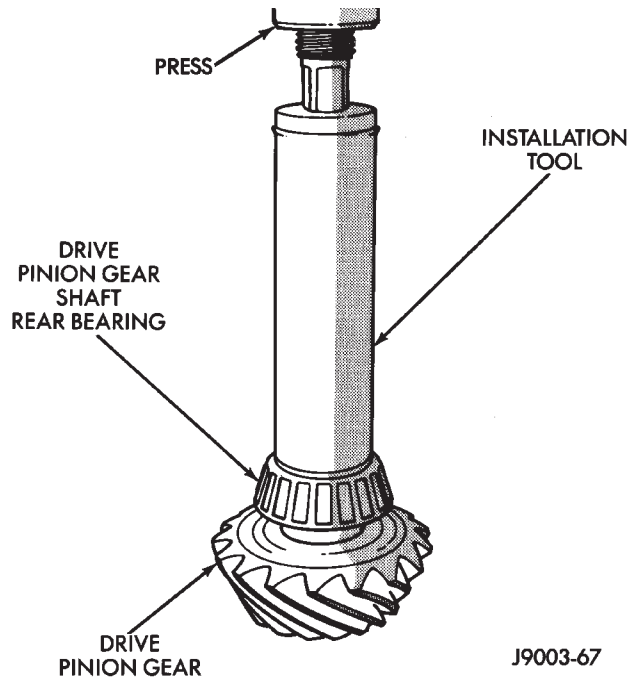


Fig. 46 Shaft Rear Bearing Installation

(6) Install a new collapsible preload spacer on pinion shaft (Fig. 47).

(7) Install pinion gear in housing.

REMOVAL AND INSTALLATION (Continued)

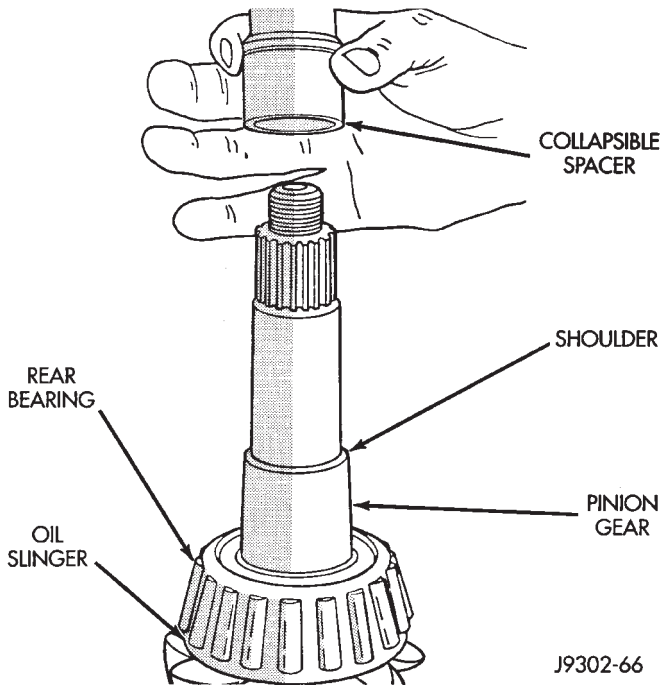


Fig. 47 Collapsible Preload Spacer

(8) Install yoke with Installer C-3718 and holder 6958 (Fig. 48).

(9) Install the yoke washer and a new nut on the pinion gear. Tighten the nut to 298 N·m (220 ft. lbs.) minimum. **Do not over-tighten.** Maximum torque is 380 N·m (280 ft. lbs.). pinion gear nut to decrease

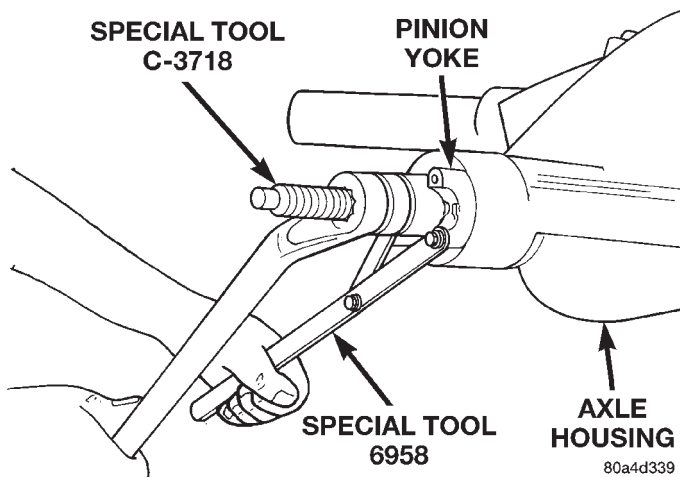


Fig. 48 Pinion Yoke Installation

CAUTION: Never loosen pinion gear nut to decrease pinion gear bearing preload torque and never exceed specified preload torque. If preload torque is exceeded a new collapsible spacer must be installed. The torque sequence will have to be repeated.

NOTE: If the spacer requires more than 280 ft. lbs. torque to crush, the collapsible spacer is defective.

(10) Using yoke holder 6958, a short length of 1 in. pipe, and a torque wrench set at 380 N·m (280 ft. lbs.), crush collapsible spacer until bearing end play is taken up (Fig. 49).

(11) Slowly tighten the nut in 6.8 N·m (5 ft. lbs.) increments until the rotating torque is achieved. Measure the rotating torque frequently to avoid over crushing the collapsible spacer (Fig. 50).

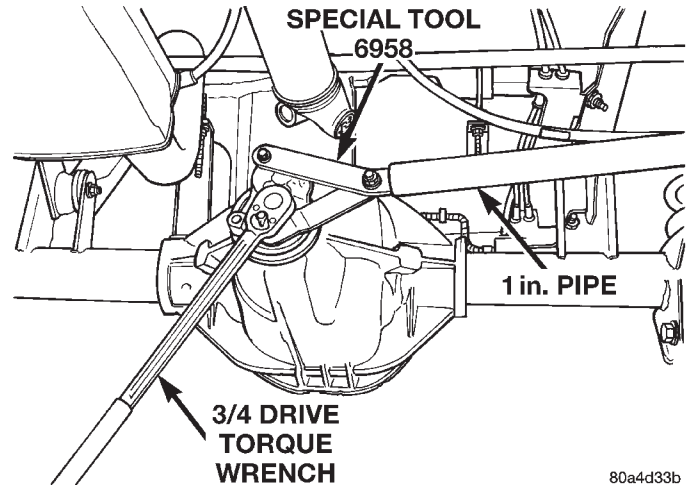


Fig. 49 Tightening Pinion Nut

(12) Check bearing rotating torque with an inch pound torque wrench (Fig. 50). The torque necessary to rotate the pinion gear should be:

- Original Bearings — 1 to 3 N·m (10 to 20 in. lbs.).
- New Bearings — 2 to 5 N·m (15 to 35 in. lbs.).

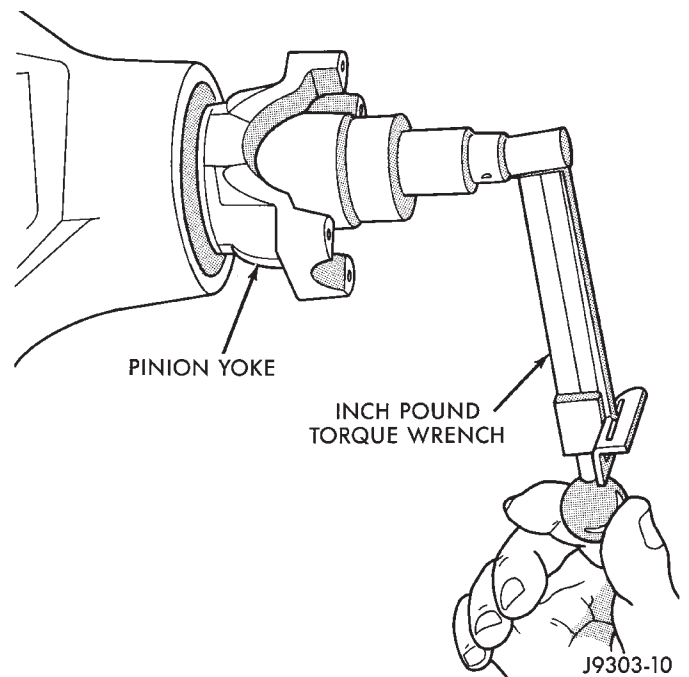


Fig. 50 Check Pinion Gear Rotation Torque

(13) Align previously made marks on yoke and propeller shaft and install propeller shaft.

(14) Install differential housing into the axle housing.

REMOVAL AND INSTALLATION (Continued)**FINAL ASSEMBLY**

(1) Scrape the residual sealant from the housing and cover mating surfaces. Clean the mating surfaces with mineral spirits. Apply a bead of Mopar® Silicone Rubber Sealant, or equivalent, on the housing cover (Fig. 51).

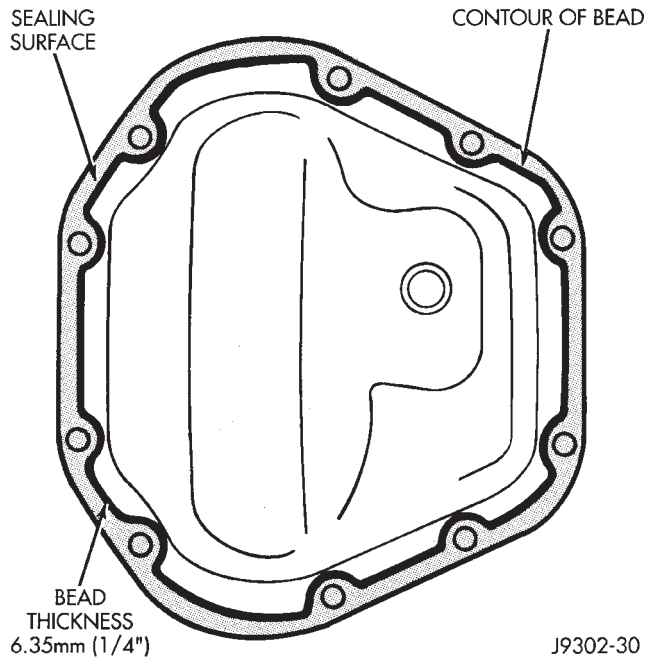


Fig. 51 Typical Housing Cover With Sealant

Install the housing cover within 5 minutes after applying the sealant.

(2) Install the cover on the differential with the attaching bolts. Install the identification tag. Tighten the cover bolts to 41 N·m (30 ft. lbs.) torque.

CAUTION: Overfilling the differential can result in lubricant foaming and overheating.

(3) Refill the differential housing with gear lubricant. Refer to the Lubricant Specifications section of this group for the gear lubricant requirements.

(4) Install the fill hole plug.

DISASSEMBLY AND ASSEMBLY**STANDARD DIFFERENTIAL****DISASSEMBLY**

(1) Remove pinion gear mate shaft lock screw (Fig. 52).

(2) Remove pinion gear mate shaft.

(3) Rotate the differential side gears and remove the pinion mate gears and thrust washers (Fig. 53).

(4) Remove the differential side gears and thrust washers.

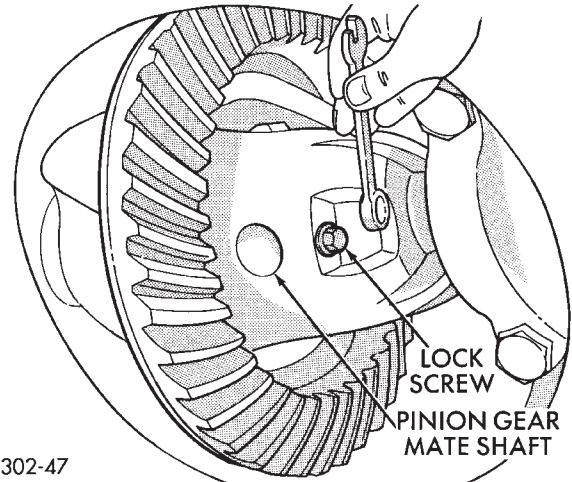


Fig. 52 Pinion Gear Mate Shaft Lock Screw

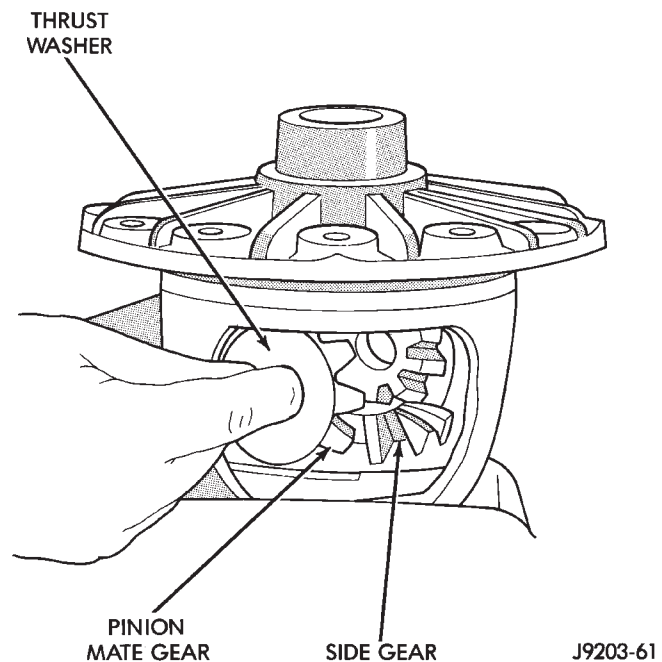


Fig. 53 Pinion Mate Gear Removal

ASSEMBLY

(1) Install the differential side gears and thrust washers.

(2) Install the pinion mate gears and thrust washers.

(3) Install the pinion gear mate shaft.

(4) Align the hole in the pinion gear mate shaft with the hole in the differential case and install the pinion gear mate shaft lock screw.

(5) Lubricate all differential components with hypoid gear lubricant.

TRAC-LOK DIFFERENTIAL

The Trac-Lok differential components are illustrated in (Fig. 54). Refer to this illustration during repair service.

DISASSEMBLY AND ASSEMBLY (Continued)

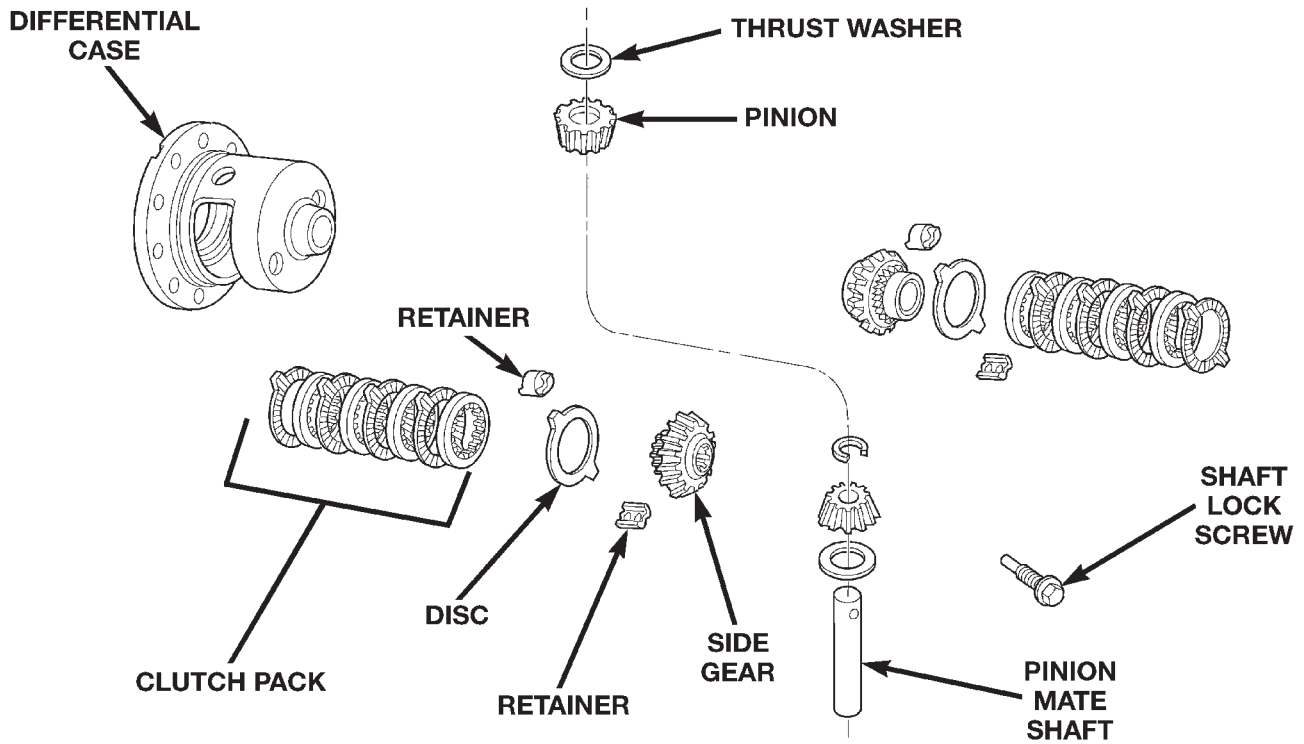


Fig. 54 Trac-Lok Differential Components

80a77404

DISASSEMBLY

- (1) Clamp Side Gear Holding Tool 6963-A in a vise.
- (2) Position the differential case on Side Gear Holding Tool 6963-A (Fig. 55).

- (3) Remove ring gear, if necessary. Ring gear removal is necessary only if the ring gear is to be replaced. The Trac-Lok differential can be serviced with the ring gear installed.
- (4) Remove the pinion gear mate shaft lock screw (Fig. 56).

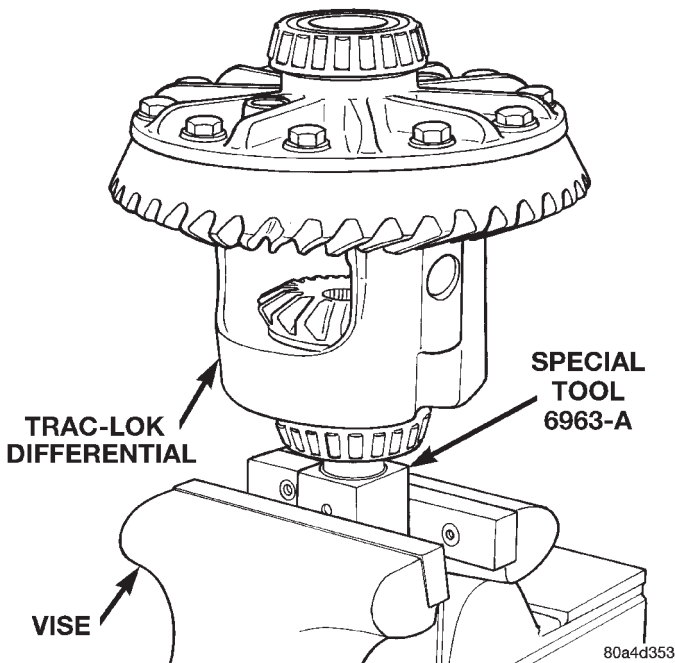
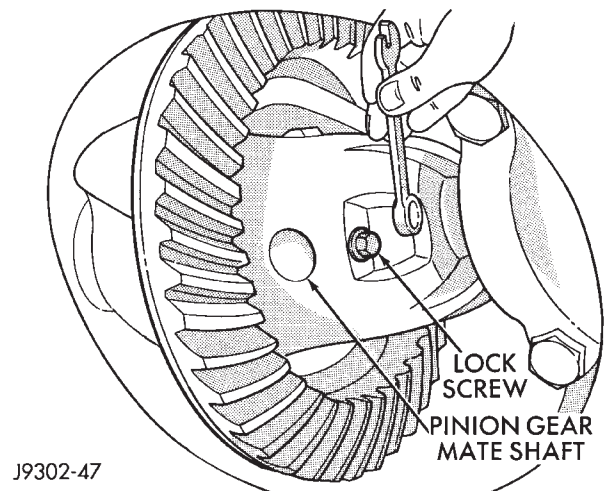


Fig. 55 Differential Case Holding Tool

80a4d353



J9302-47

Fig. 56 Mate Shaft Lock Screw

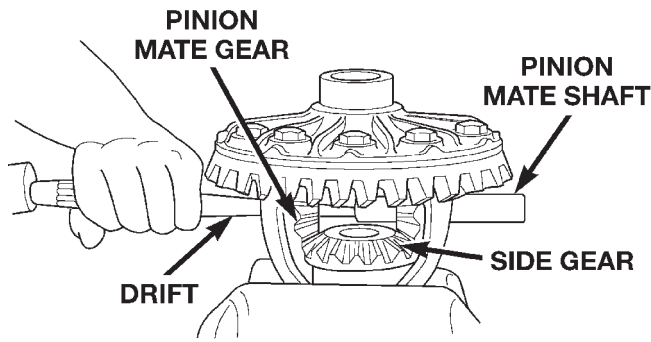
DISASSEMBLY AND ASSEMBLY (Continued)

(5) Remove the pinion gear mate shaft. If necessary, use a drift and hammer (Fig. 57).

(6) Install and lubricate Step Plate C-4487-1 (Fig. 58).

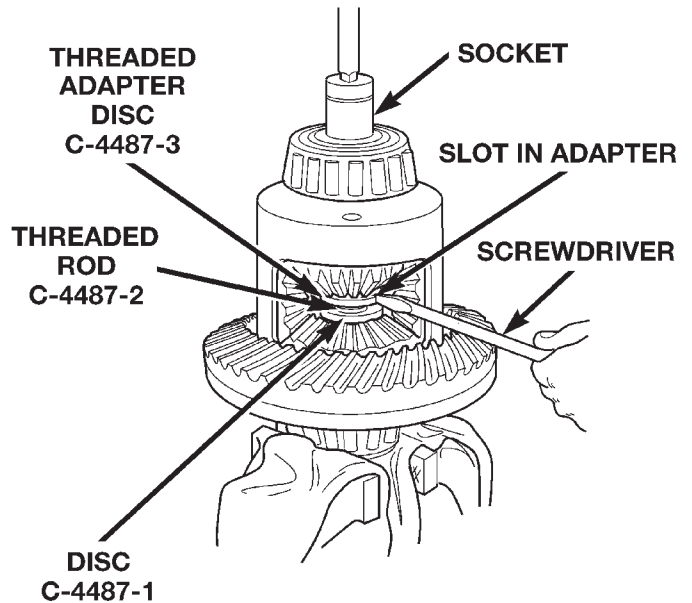
(7) Assemble Threaded Adapter C-4487-3 into top side gear. Thread Forcing Screw C-4487-2 into adapter until it becomes centered in adapter plate.

(8) Position a small screw driver in slot of Threaded Adapter C-4487-3 (Fig. 59) to prevent adapter from turning.



80a773e1

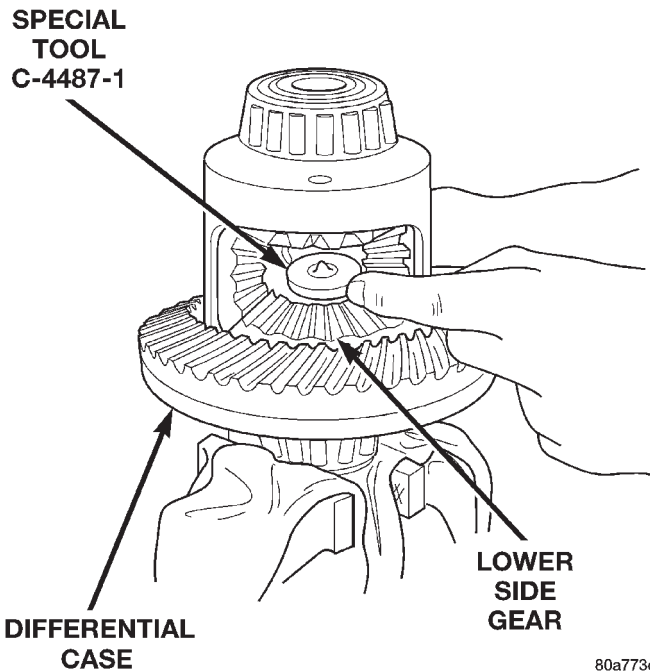
Fig. 57 Mate Shaft Removal



80a773de

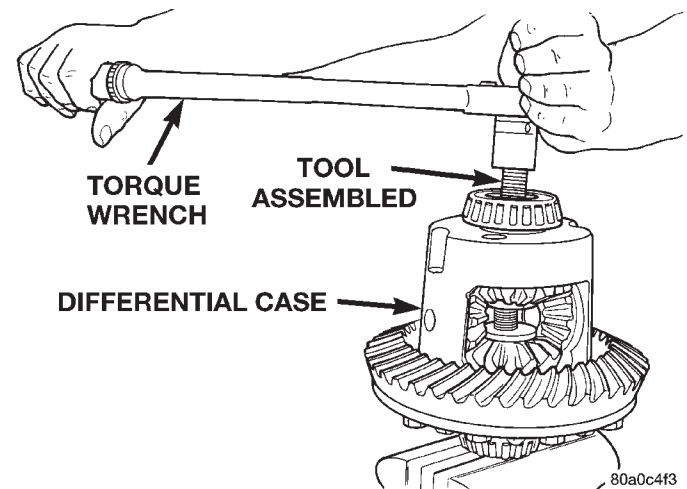
Fig. 59 Threaded Adapter Installation

(9) Tighten forcing screw tool 122 N·m (90 ft. lbs.) (maximum) to compress Belleville springs in clutch packs (Fig. 60).



80a773df

Fig. 58 Step Plate Tool Installation



80a0c4f3

Fig. 60 Tighten Belleville Spring Compressor Tool

DISASSEMBLY AND ASSEMBLY (Continued)

(10) Using an appropriate size feeler gauge, remove thrust washers from behind the pinion gears (Fig. 61).

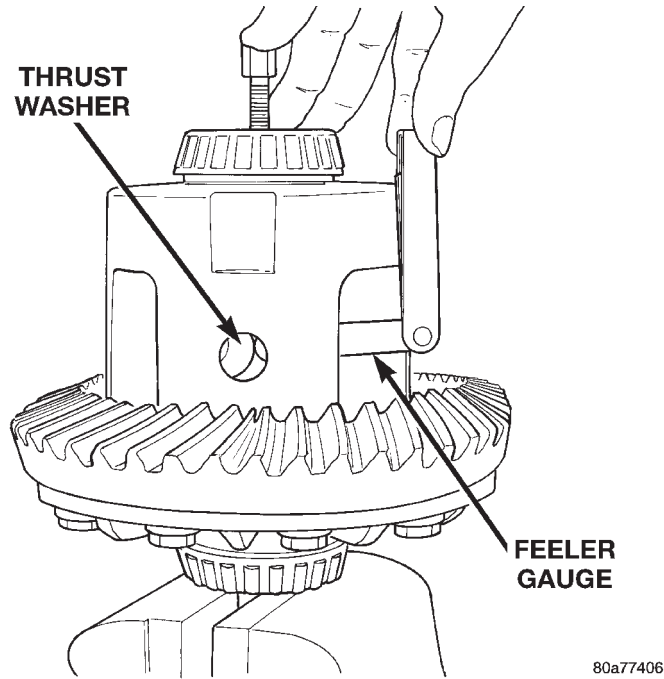


Fig. 61 Remove Pinion Gear Thrust Washer

(11) Insert Turning Bar C-4487-4 in case (Fig. 62).

(12) Loosen the Forcing Screw C-4487-2 in small increments until the clutch pack tension is relieved and the differential case can be turned using Turning Bar C-4487-4.

(13) Rotate differential case until the pinion gears can be removed.

(14) Remove pinion gears from differential case.

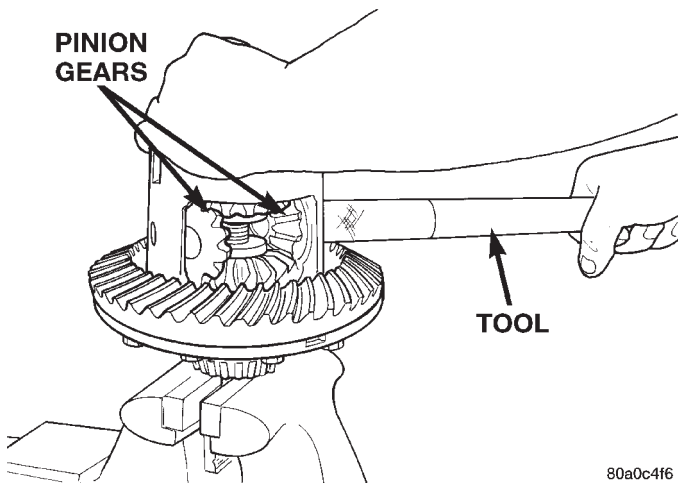


Fig. 62 Pinion Gear Removal

(15) Remove Forcing Screw C-4487-2, Step Plate C-4487-1, and Threaded Adapter C-4487-3.

(16) Remove top side gear, clutch pack retainer, and clutch pack. Keep plates in correct order during removal (Fig. 63).

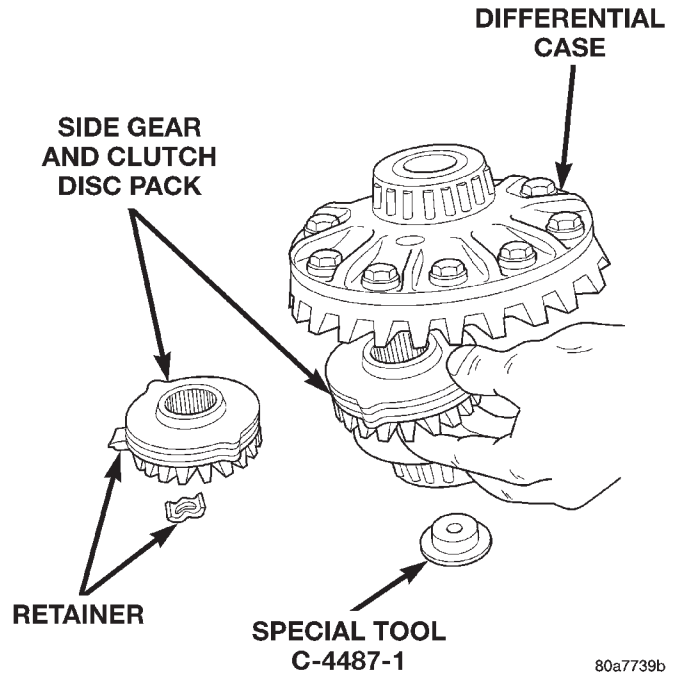


Fig. 63 Side Gear & Clutch Disc Removal

(17) Remove differential case from Side Gear Holding Tool 6963-A. Remove side gear, clutch pack retainer, and clutch pack. Keep plates in correct order during removal.

ASSEMBLY

NOTE: The clutch discs are replaceable as complete sets only. If one clutch disc pack is damaged, both packs must be replaced.

Lubricate each component with gear lubricant before assembly.

(1) Assemble the clutch discs into packs and secure disc packs with retaining clips (Fig. 64).

(2) Position assembled clutch disc packs on the side gear hubs.

(3) Install clutch pack and side gear in the ring gear side of the differential case (Fig. 65). **Be sure clutch pack retaining clips remain in position and are seated in the case pockets.**

(4) Position the differential case on Side Gear Holding Tool 6963-A.

(5) Install lubricated Step Plate C-4487-1 on side gear (Fig. 66).

(6) Install the upper side gear and clutch disc pack (Fig. 66).

(7) Hold assembly in position. Insert Threaded Adapter C-4487-3 into top side gear.

(8) Insert Forcing Screw C-4487-2.

DISASSEMBLY AND ASSEMBLY (Continued)

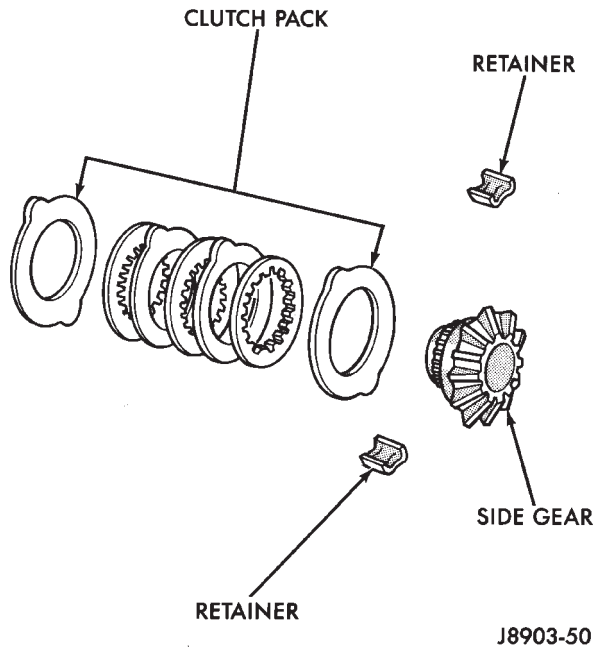


Fig. 64 Clutch Disc Pack

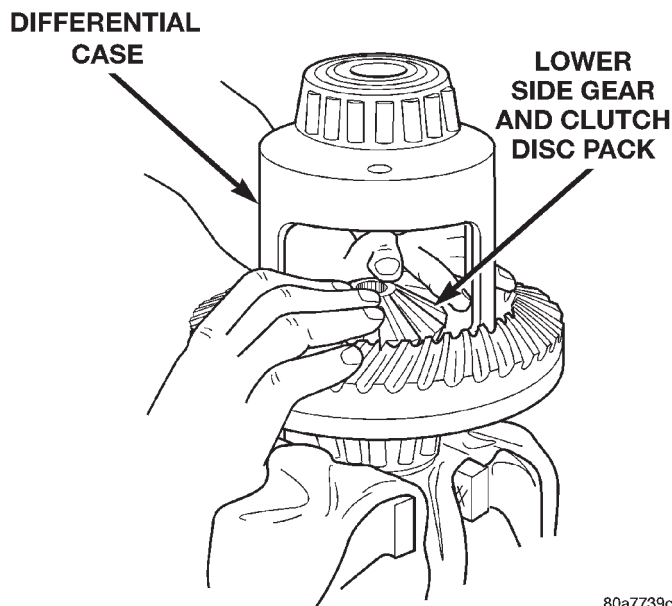


Fig. 65 Clutch Discs & Lower Side Gear Installation

(9) Tighten forcing screw tool to slightly compress clutch discs.

(10) Place pinion gears in position in side gears and verify that the pinion mate shaft hole is aligned.

(11) Rotate case with Turning Bar C-4487-4 until the pinion mate shaft holes in pinion gears align with holes in case. It may be necessary to slightly tighten the forcing screw in order to install the pinion gears.

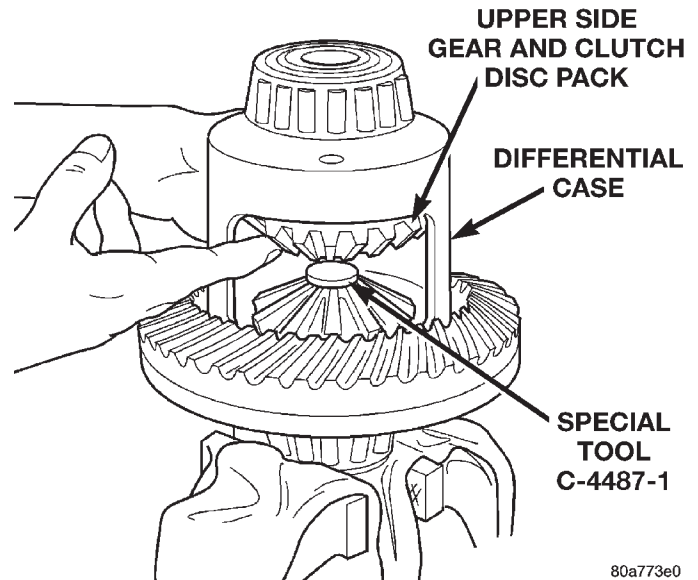


Fig. 66 Upper Side Gear & Clutch Disc Pack Installation

(12) Tighten forcing screw to 122 N·m (90 ft. lbs.) to compress the Belleville springs.

(13) Lubricate and install thrust washers behind pinion gears and align washers with a small screw driver. Insert mate shaft into each pinion gear to verify alignment.

(14) Remove forcing screw, threaded adapter, and step plate.

(15) Install pinion gear mate shaft and align holes in shaft and case.

(16) Install the pinion mate shaft lock screw finger tight to hold shaft during differential installation.

If replacement side and/or pinion gears and thrust washers were installed, it is not necessary to measure the side gear backlash. Correct fit is due to close machining tolerances during manufacture.

(17) Lubricate all differential components with hypoid gear lubricant.

CLEANING AND INSPECTION

AXLE COMPONENTS

Wash differential components with cleaning solvent and dry with compressed air. **Do not steam clean the differential components.**

Wash bearings with solvent and towel dry, or dry with compressed air. **DO NOT** spin bearings with compressed air. **Cup and bearing must be replaced as matched sets only.**

Clean axle shaft tubes and oil channels in housing. Inspect for;

CLEANING AND INSPECTION (Continued)

- Smooth appearance with no broken/dented surfaces on the bearing rollers or the roller contact surfaces.
- Bearing cups must not be distorted or cracked.
- Machined surfaces should be smooth and without any raised edges.
- Raised metal on shoulders of cup bores should be removed with a hand stone.
- Wear and damage to pinion gear mate shaft, pinion gears, side gears and thrust washers. Replace as a matched set only.
- Ring and pinion gear for worn and chipped teeth.
- Ring gear for damaged bolt threads. Replaced as a matched set only.
- Pinion yoke for cracks, worn splines, pitted areas, and a rough/corroded seal contact surface. Repair or replace as necessary.
- Preload shims for damage and distortion. Install new shims, if necessary.

TRAC-LOK

Clean all components in cleaning solvent. Dry components with compressed air. Inspect clutch pack plates for wear, scoring or damage. Replace both clutch packs if any one component in either pack is damaged. Inspect side and pinion gears. Replace any gear that is worn, cracked, chipped or damaged. Inspect differential case and pinion shaft. Replace if worn or damaged.

PRESOAK PLATES AND DISC

Plates and discs with fiber coating (no grooves or lines) must be presoaked in Friction Modifier before assembly. Soak plates and discs for a minimum of 20 minutes.

ADJUSTMENTS

PINION GEAR DEPTH

GENERAL INFORMATION

Ring and pinion gears are supplied as matched sets only. The identifying numbers for the ring and pinion gear are etched into the face of each gear (Fig. 67). A plus (+) number, minus (-) number or zero (0) is etched into the face of the pinion gear. This number is the amount (in thousandths of an inch) the depth varies from the standard depth setting of a pinion etched with a (0). The standard setting from the center line of the ring gear to the back face of the pinion is 109.52 mm (4.312 in.). The standard depth provides the best teeth contact pattern. Refer to Backlash and Contact Pattern Analysis Paragraph in this section for additional information.

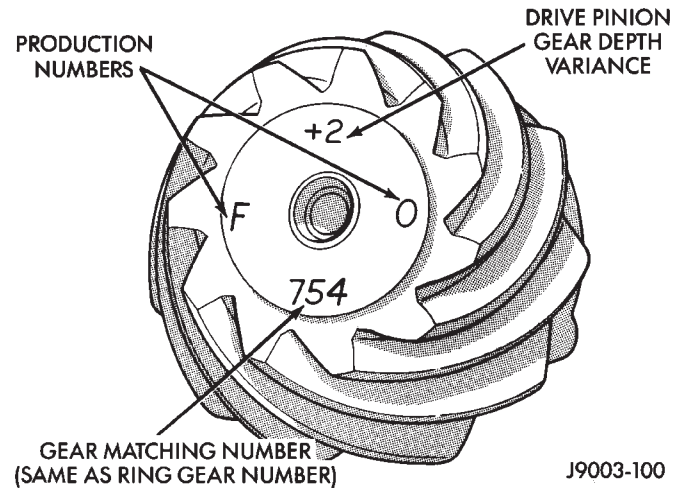


Fig. 67 Pinion Gear ID Numbers

Compensation for pinion depth variance is achieved with select shims. The shims are placed under the inner pinion bearing cone (Fig. 68).

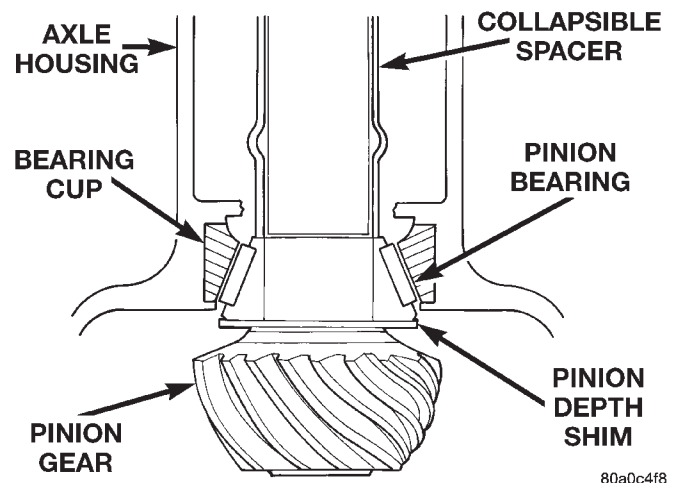


Fig. 68 Shim Locations

If a new gear set is being installed, note the depth variance etched into both the original and replacement pinion gear. Add or subtract the thickness of the original depth shims to compensate for the difference in the depth variances. Refer to the Depth Variance charts.

Note where Old and New Pinion Marking columns intersect. Intersecting figure represents plus or minus amount needed.

Note the etched number on the face of the drive pinion gear (-1, -2, 0, +1, +2, etc.). The numbers represent thousands of an inch deviation from the standard. If the number is negative, add that value to the required thickness of the depth shim(s). If the number is positive, subtract that value from the thickness of the depth shim(s). If the number is 0, no change is necessary. Refer to the Pinion Gear Depth Variance Chart.

ADJUSTMENTS (Continued)

PINION GEAR DEPTH VARIANCE

Original Pinion Gear Depth Variance	Replacement Pinion Gear Depth Variance								
	-4	-3	-2	-1	0	+1	+2	+3	+4
+4	+0.008	+0.007	+0.006	+0.005	+0.004	+0.003	+0.002	+0.001	0
+3	+0.007	+0.006	+0.005	+0.004	+0.003	+0.002	+0.001	0	-0.001
+2	+0.006	+0.005	+0.004	+0.003	+0.002	+0.001	0	-0.001	-0.002
+1	+0.005	+0.004	+0.003	+0.002	+0.001	0	-0.001	-0.002	-0.003
0	+0.004	+0.003	+0.002	+0.001	0	-0.001	-0.002	-0.003	-0.004
-1	+0.003	+0.002	+0.001	0	-0.001	-0.002	-0.003	-0.004	-0.005
-2	+0.002	+0.001	0	-0.001	-0.002	-0.003	-0.004	-0.005	-0.006
-3	+0.001	0	-0.001	-0.002	-0.003	-0.004	-0.005	-0.006	-0.007
-4	0	-0.001	-0.002	-0.003	-0.004	-0.005	-0.006	-0.007	-0.008

J8902-46

PINION DEPTH MEASUREMENT AND ADJUSTMENT

Measurements are taken with pinion cups and pinion bearings installed in housing. Take measurements with Pinion Gauge Set 6955, Dummy Bearing/Arbor Disc Set 6956, and Dial Indicator C-3339 (Fig. 69).

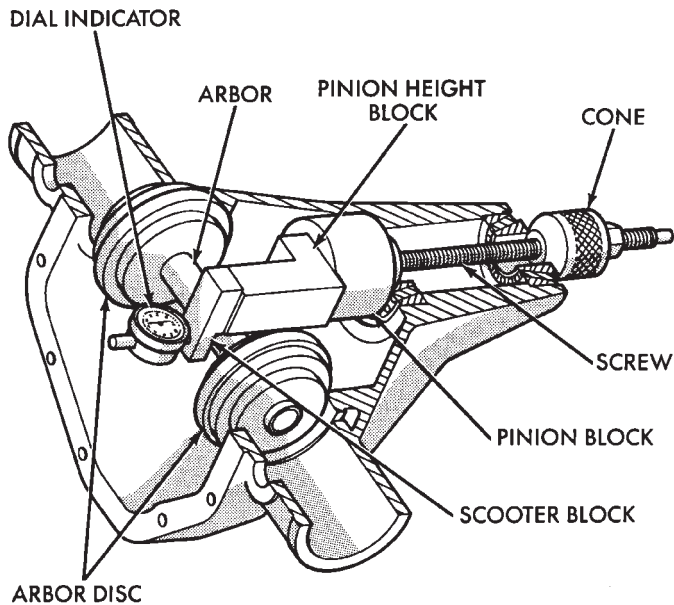


Fig. 69 Pinion Gear Depth Gauge Tools—Typical

(1) Assemble Pinion Height Block 6739, Pinion Block 8144, and rear pinion bearing onto Screw 6741 (Fig. 69).

(2) Insert assembled height gauge components, rear bearing and screw into axle housing through pinion bearing cups (Fig. 70).

(3) Install front pinion bearing and Cone 6740 hand tight (Fig. 69).

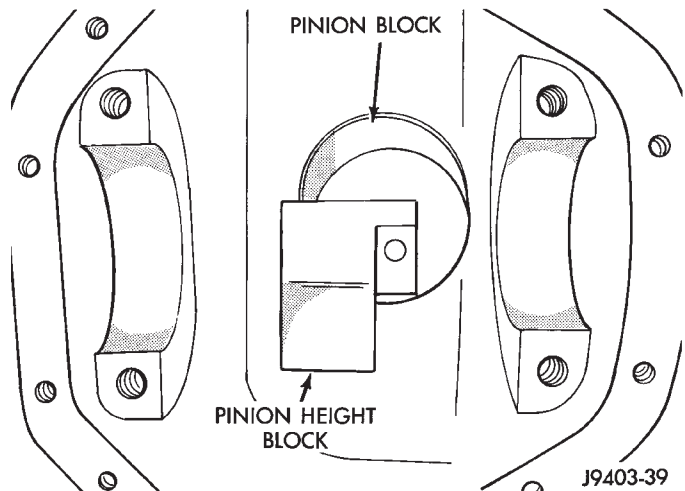


Fig. 70 Pinion Height Block—Typical

(4) Place Arbor Disc 6927 on Arbor D-115-3 in position in axle housing side bearing cradles (Fig. 71). Install differential bearing caps on Arbor Discs and tighten cap bolts. Refer to the Torque Specifications in this section.

ADJUSTMENTS (Continued)

NOTE: Arbor Discs 6927 have different step diameters to fit other axle sizes. Pick correct size step for axle being serviced.

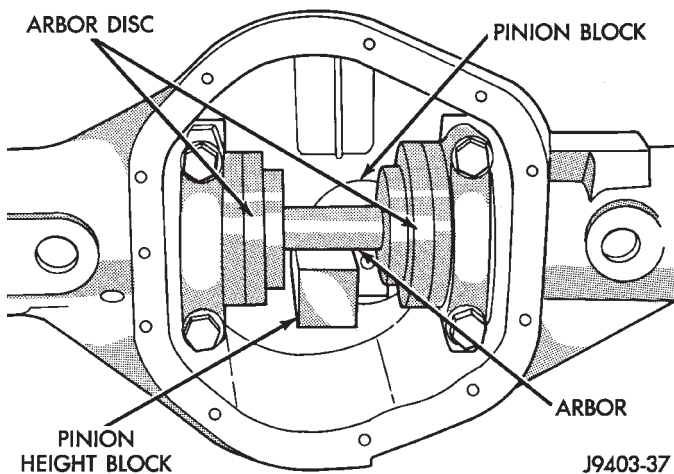


Fig. 71 Gauge Tools In Housing—Typical

(5) Assemble Dial Indicator C-3339 into Scooter Block D-115-2 and secure set screw.

(6) Place Scooter Block/Dial Indicator in position in axle housing so dial probe and scooter block are flush against the surface of the pinion height block. Hold scooter block in place and zero the dial indicator face to the pointer. Tighten dial indicator face lock screw.

(7) With scooter block still in position against the pinion height block, slowly slide the dial indicator over the edge of the pinion height block. Observe how many revolutions counterclockwise the dial pointer travels (approximately 0.125 in.) to the out-stop of the dial indicator.

(8) Slide the dial indicator probe across the gap between the pinion height block and the arbor bar with the scooter block against the pinion height block (Fig. 72). When the dial probe contacts the arbor bar, the dial pointer will turn clockwise. Bring dial pointer back to zero against the arbor bar, do not turn dial face. Continue moving the dial probe to the crest of the arbor bar and record the highest reading. If the dial indicator can not achieve the zero reading, the rear bearing cup or the pinion depth gauge set is not installed correctly.

(9) Select a shim equal to the dial indicator reading plus the drive pinion gear depth variance number etched in the face of the pinion gear (Fig. 67) using the opposite sign on the variance number. For example, if the depth variance is -2 , add $+0.002$ in. to the dial indicator reading.

(10) Remove the pinion depth gauge components from the axle housing

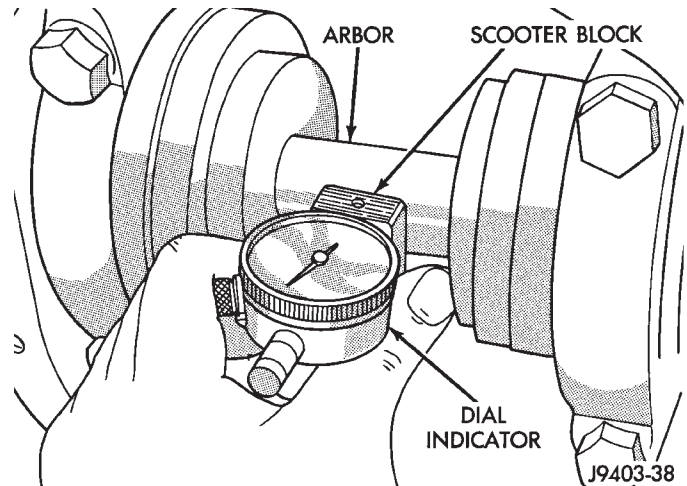


Fig. 72 Pinion Gear Depth Measurement—Typical

DIFFERENTIAL BEARING PRELOAD AND GEAR BACKLASH

Differential side bearing preload and gear backlash is achieved by selective shims inserted between the bearing cup and the axle housing. The proper shim thickness can be determined using slip-fit dummy bearings 6929-A in place of the differential side bearings and a dial indicator C-3339. Before proceeding with the differential bearing preload and gear backlash measurements, measure the pinion gear depth and prepare the pinion gear for installation. Establishing proper pinion gear depth is essential to establishing gear backlash and tooth contact patterns. After the overall shim thickness to take up differential side play is measured, the pinion gear is installed, and the gear backlash shim thickness is measured. The overall shim thickness is the total of the dial indicator reading, starting point shim thickness, and the preload specification added together. The gear backlash measurement determines the thickness of the shim used on the ring gear side of the differential case. Subtract the gear backlash shim thickness from the total overall shim thickness and select that amount for the pinion gear side of the differential (Fig. 73).

DIFFERENTIAL PRELOAD AND GEAR BACKLASH SHIM SELECTION

NOTE: It is difficult to salvage the differential side bearings during the removal procedure. Install replacement bearings if necessary.

- (1) Remove side bearings from differential case.
- (2) Install ring gear on differential case and tighten bolts to specification.
- (3) Install dummy side bearings 6929-A on differential case.
- (4) Install differential case in axle housing.

ADJUSTMENTS (Continued)

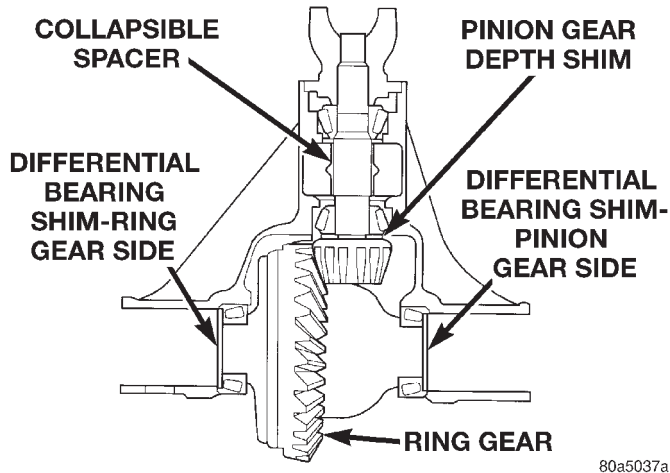


Fig. 73 Axle Adjustment Shim Locations

(5) Insert Dummy Shim 8107 (0.118 in. (3.0 mm)) starting point shims between the dummy bearing and the axle housing on side of differential (Fig. 74).

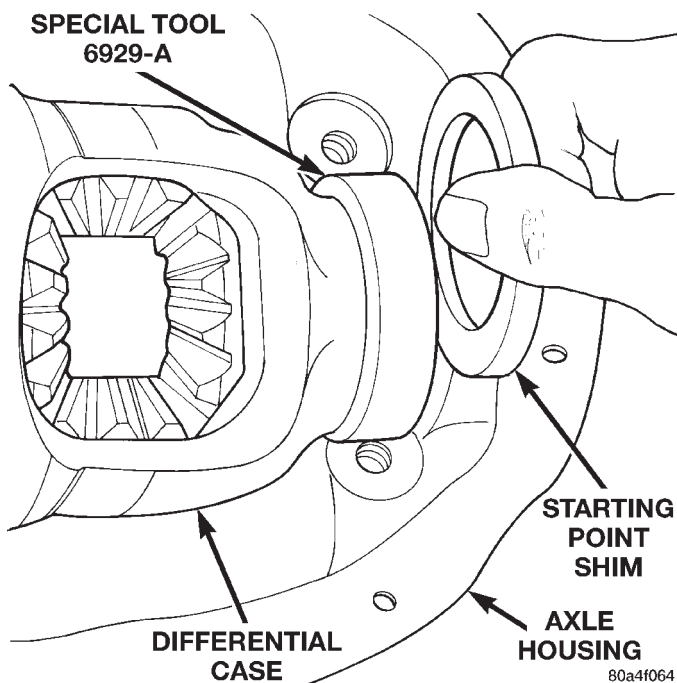


Fig. 74 Preload Measurement Starting Point Shim

(6) Install the marked bearing caps in their correct positions. Install and snug the bolts.

(7) Thread guide stud C-3288-B into rear cover bolt hole below ring gear (Fig. 75).

(8) Attach dial indicator C-3339 to Guide Stud C-3288-B. Position the dial indicator plunger on a flat surface between the ring gear bolt heads (Fig. 75).

(9) Push and hold differential case to pinion gear side of axle housing.

(10) Zero dial indicator face to pointer.

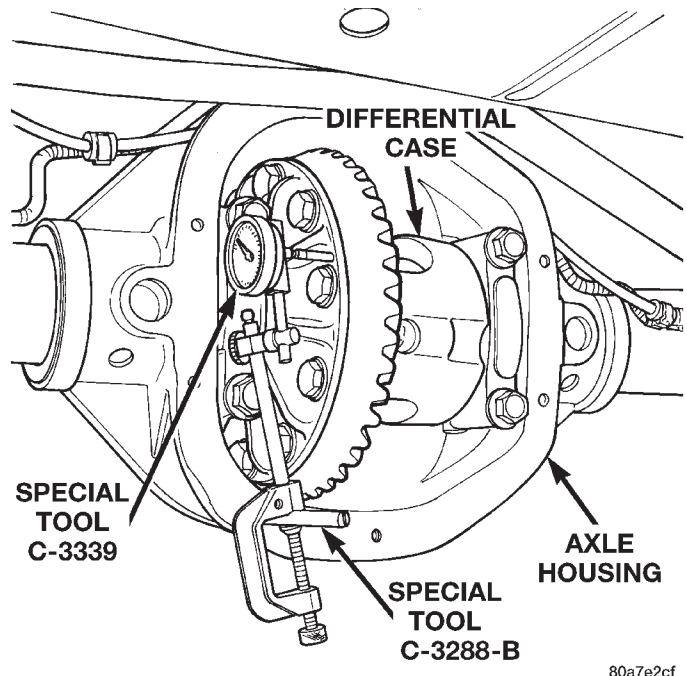


Fig. 75 Differential Side play Measurement

(11) Push and hold differential case to ring gear side of the axle housing.

(12) Record dial indicator reading.

(13) Add the dial indicator reading to the starting point shim thickness to determine total shim thickness to achieve zero differential end play.

(14) Add 0.012 in. (0.3 mm) to the zero end play total. This new total represents the thickness of shims to compress, or preload the new bearings when the differential is installed.

(15) Rotate dial indicator out of the way on guide stud.

(16) Remove differential case, dummy bearings, and starting point shims from axle housing.

(17) Install pinion gear in axle housing. Install the yoke and establish the correct pinion rotating torque.

(18) Install differential case and dummy bearings in axle housing (without shims) and tighten retaining cap bolts snug.

(19) Position the dial indicator plunger on a flat surface between the ring gear bolt heads (Fig. 75).

(20) Push and hold differential case toward pinion gear.

(21) Zero dial indicator face to pointer.

(22) Push and hold differential case to ring gear side of the axle housing.

(23) Record dial indicator reading.

(24) Subtract 0.002 in. (0.05 mm) from the dial indicator reading to compensate for backlash between ring and pinion gears. This total is the thickness of shim required to achieve proper backlash.

(25) Subtract the backlash shim thickness from the total preload shim thickness. The remainder is

ADJUSTMENTS (Continued)

the shim thickness required on the pinion side of the axle housing.

(26) Rotate dial indicator out of the way on guide stud.

(27) Remove differential case and dummy bearings from axle housing.

(28) Install new side bearing cones and cups on differential case.

(29) Install spreader W-129-B on axle housing and spread axle opening enough to receive differential case and side bearing shims.

(30) Place side bearing shims in axle housing against axle tube ends.

(31) Install differential case in axle housing.

(32) Remove spreader from axle housing.

(33) Rotate the differential case several times to seat the side bearings.

(34) Position the indicator plunger against a ring gear tooth (Fig. 76).

(35) Push and hold ring gear upward while not allowing the pinion gear to rotate.

(36) Zero dial indicator face to pointer.

(37) Push and hold ring gear downward while not allowing the pinion gear to rotate. Dial indicator reading should be between 0.12 mm (0.005 in.) and 0.20 mm (0.008 in.). If backlash is not within specifications transfer the necessary amount of shim thickness from one side of the axle housing to the other (Fig. 77).

(38) Verify differential case and ring gear runout by measuring ring to pinion gear backlash at several locations around the ring gear. Readings should not vary more than 0.05 mm (0.002 in.). If readings vary more than specified, the ring gear or the differential case is defective.

After the proper backlash is achieved, perform the Gear Contact Pattern Analysis procedure.

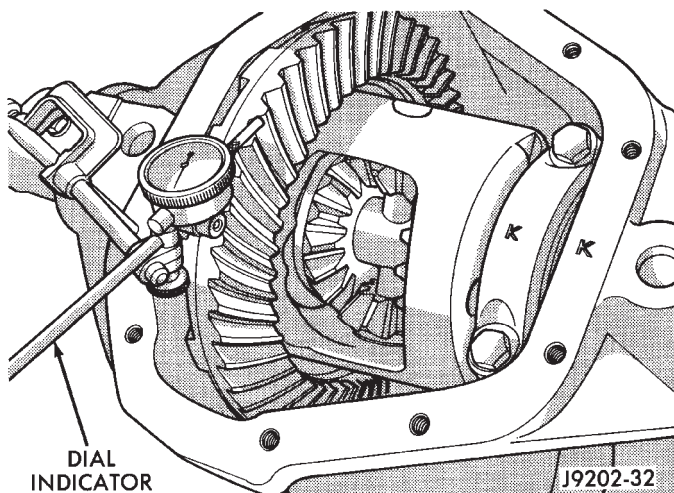


Fig. 76 Ring Gear Backlash Measurement

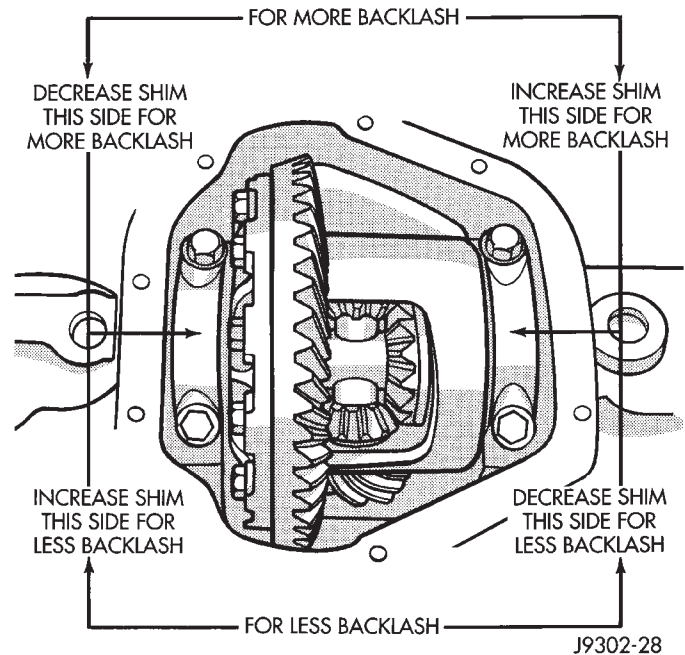


Fig. 77 Backlash Shim Adjustment

GEAR CONTACT PATTERN ANALYSIS

The ring and pinion gear teeth contact patterns will show if the pinion gear depth is correct in the axle housing. It will also show if the ring gear backlash has been adjusted correctly. The backlash can be adjusted within specifications to achieve desired tooth contact patterns.

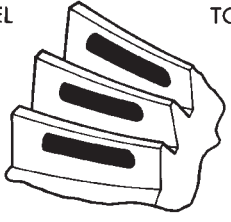
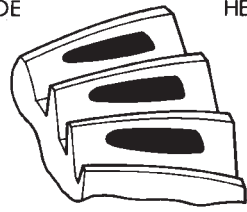
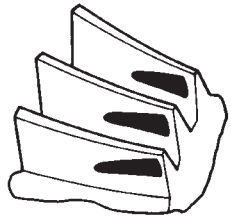
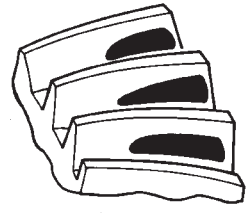
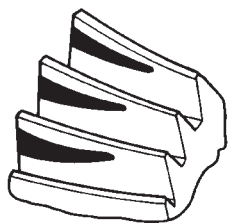
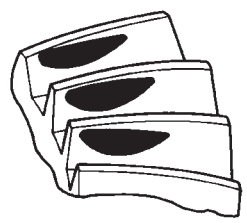
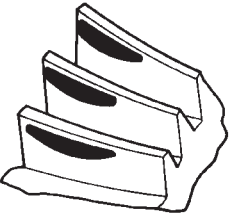
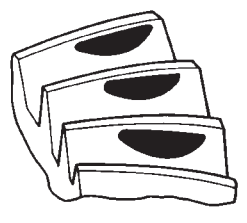
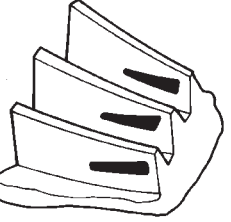
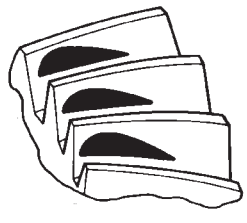
(1) Apply a thin coat of hydrated ferric oxide, or equivalent, to the drive and coast side of the ring gear teeth.

(2) Wrap, twist, and hold a shop towel around the pinion yoke to increase the turning resistance of the pinion gear. This will provide a more distinct contact pattern.

(3) Using a boxed end wrench on a ring gear bolt, rotate the differential case one complete revolution in both directions while a load is being applied from shop towel.

The areas on the ring gear teeth with the greatest degree of contact against the pinion gear teeth will squeegee the compound to the areas with the least amount of contact. Note and compare patterns on the ring gear teeth to Gear Tooth Contact Patterns chart (Fig. 78) and adjust pinion depth and gear backlash as necessary.

ADJUSTMENTS (Continued)

<p>DRIVE SIDE OF RING GEAR TEETH</p> <p>HEEL TOE</p> 	<p>COAST SIDE OF RING GEAR TEETH</p> <p>TOE HEEL</p> 	<p>DESIRABLE CONTACT PATTERN. PATTERN SHOULD BE CENTERED ON THE DRIVE SIDE OF TOOTH. PATTERN SHOULD BE CENTERED ON THE COAST SIDE OF TOOTH, BUT MAY BE SLIGHTLY TOWARD THE TOE. THERE SHOULD ALWAYS BE SOME CLEARANCE BETWEEN CONTACT PATTERN AND TOP OF THE TOOTH.</p>
		<p>RING GEAR BACKLASH CORRECT. THINNER PINION GEAR DEPTH SHIM REQUIRED.</p>
		<p>RING GEAR BACKLASH CORRECT. THICKER PINION GEAR DEPTH SHIM REQUIRED.</p>
		<p>PINION GEAR DEPTH SHIM CORRECT. DECREASE RING GEAR BACKLASH.</p>
		<p>PINION GEAR DEPTH SHIM CORRECT. INCREASE RING GEAR BACKLASH.</p>

J9003-24

Fig. 78 Gear Tooth Contact Patterns

SPECIFICATIONS

216 RBA AXLE

DESCRIPTION	SPECIFICATION
Axle Type	Semi-Floating Hypoid
Lubricant.	SAE Thermally Stable 80W-90
Lubricant Trailer Tow	Synthetic 75W-140
Lube Capacity2.25 L (4.75 pts.)
Axle Ratios.3.55/3.73
Differential Bearing Preload0.1 mm (0.004 in.)
Differential Side Gear Clearance0-0.15 mm (0-0.006 in.)
Ring Gear Diameter216 mm (8.5 in.)
Ring Gear Backlash0.13-0.20 mm (0.005-0.008 in.)
Pinion Std. Depth.109.52 mm (4.312 in.)
Pinion Bearing Preload- New Bearings2.26-4.52 N·m (20-40 in. lbs.)
Pinion Bearing Preload- Original Bearings1-3 N·m (10-20 in. lbs.)
Maximum Carrier Spread0.51 mm (0.020 in.)

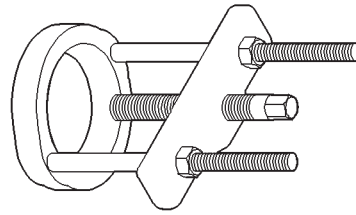
TORQUE

DESCRIPTION	TORQUE
Bolts, Diff. Cover41 N·m (30 ft. lbs.)
Bolts, Diff. Bearing Cap85 N·m (63 ft. lbs.)
Bolts, Ring Gear108 N·m (80 ft. lbs.)
Screw, ABS Sensor8 N·m (70 in. lbs.)
Screw, Pinion Gear Mate Shaft Lock17.6 N·m (13 ft. lbs.)
Nuts, Brake Backing Plate61 N·m (45 ft. lbs.)
Nut, Pinion Gear—Minimum *298 N·m (220 ft. lbs.)
Nut, Pinion Gear—Maximum *380 N·m (280 ft. lbs.)

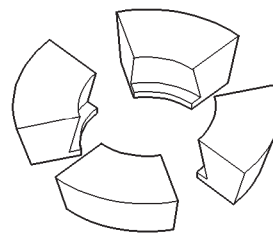
NOTE: *Refer to Pinion Gear Removal and Installation procedures for proper pinion nut tightening instructions. Do not exceed 380 N·m (280 ft. lbs.) during collapsible spacer crushing procedure.

SPECIAL TOOLS

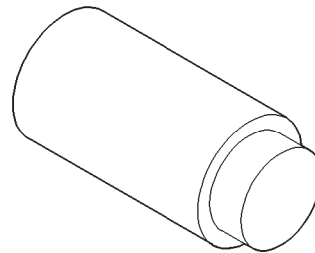
216 RBA AXLE



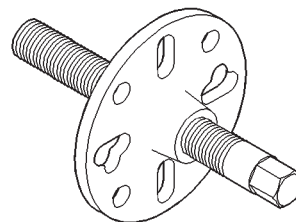
Puller Set—C-293-PA



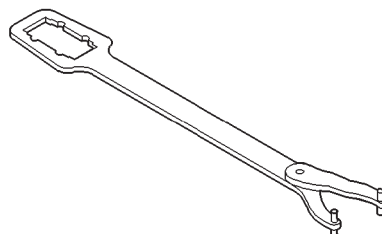
Adapter—C-293-42



Extension—C-293-3

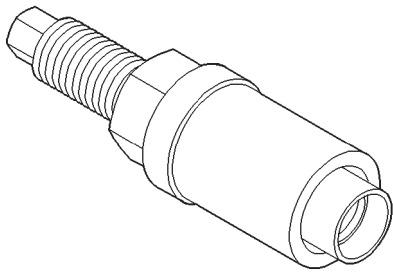


Remover—C-452

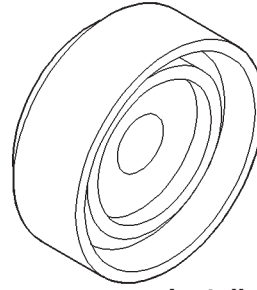


Holder—C-3281

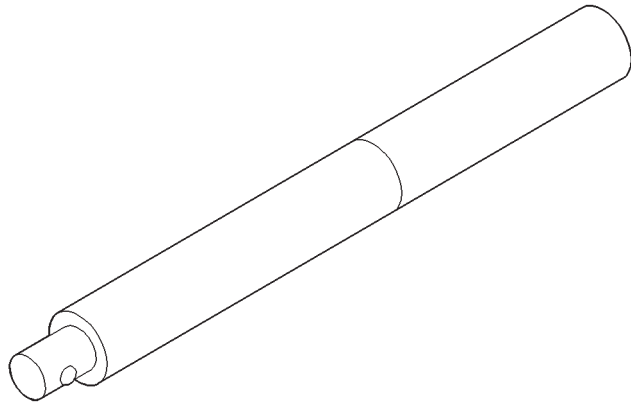
SPECIAL TOOLS (Continued)



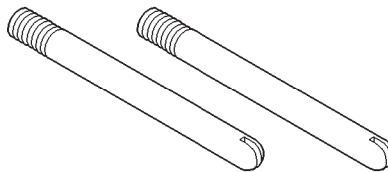
Installer—C-3718



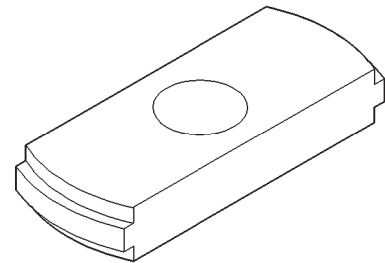
Installer—C-4340



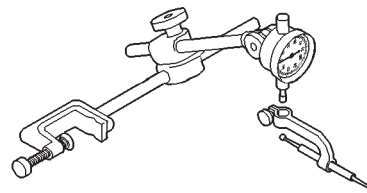
Handle—C-4171



Guide Pin—C-3288-B

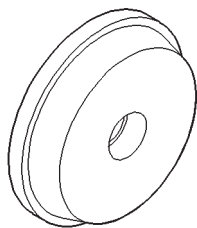


Remover—C-4307

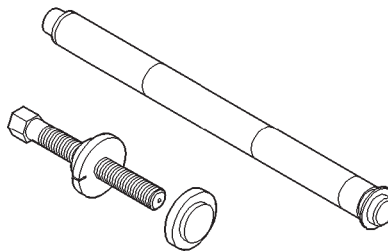


Dial Indicator—C-3339

8011d42b

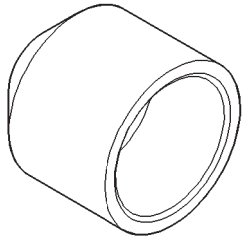


Installer—C-4308

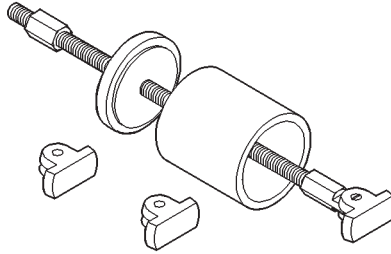


Trac-lok Tool Set—C-4487

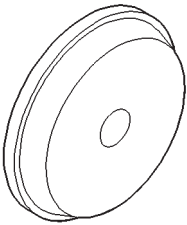
SPECIAL TOOLS (Continued)



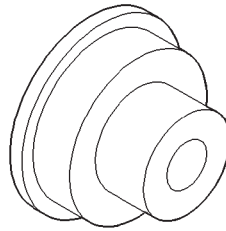
Installer—C-3972-A



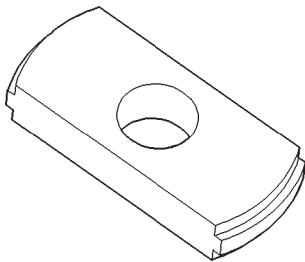
Remover—6310



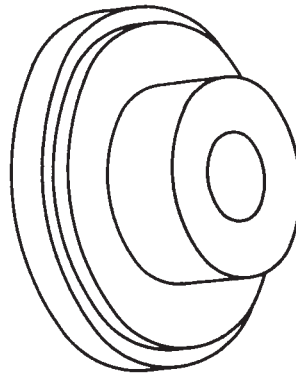
Installer—D-129



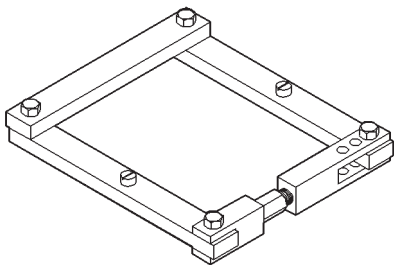
Installer—6436



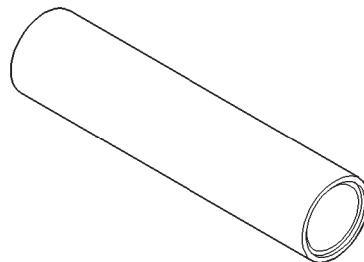
Remover—D-103



Installer—6437

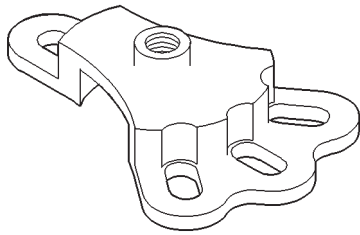


Spreader—W-129-B

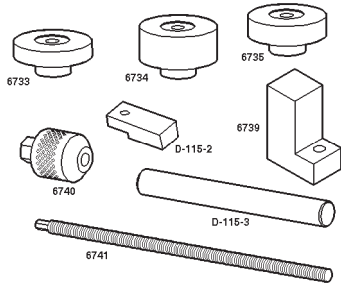


Installer—6448

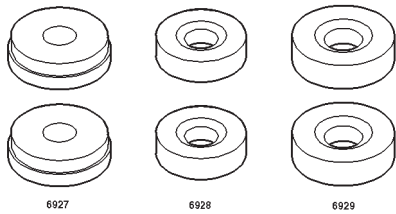
SPECIAL TOOLS (Continued)



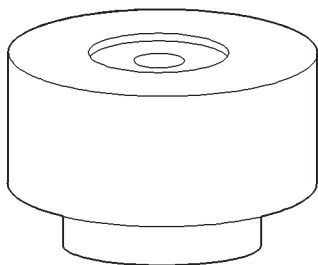
Adapter—6790



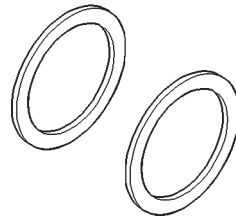
Pinion Depth Set—6955



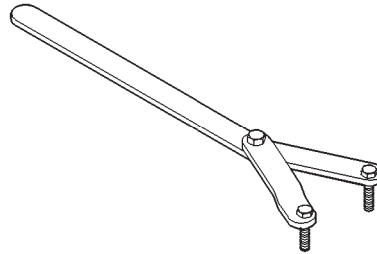
Adapter Set—6956



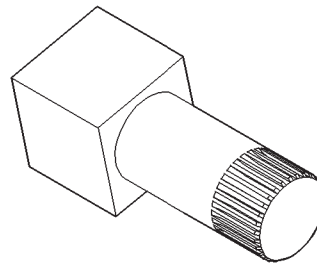
Gauge Block—8144



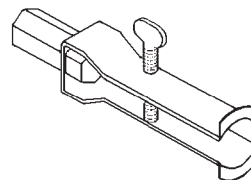
Starting Point Shim—8107



Holder—6958



Holder—6963-A



Remover—7794-A

BRAKES

CONTENTS

	page		page
ANTILOCK BRAKES	35	BASE BRAKE SYSTEM	1

BASE BRAKE SYSTEM

INDEX

	page		page
GENERAL INFORMATION		COMBINATION VALVE	15
BRAKE SYSTEM	2	DISC BRAKE CALIPER	16
SERVICE WARNINGS & CAUTIONS	2	DISC BRAKE ROTOR	19
DESCRIPTION AND OPERATION		DISC BRAKE SHOES	18
BRAKE HOSES AND LINES	5	FRONT PARKING BRAKE CABLE	22
BRAKE PEDAL	2	MASTER CYLINDER	15
COMBINATION VALVE	4	PARKING BRAKE CAM AND LEVER	24
FRONT DISC BRAKES	4	PARKING BRAKE HAND LEVER	21
MASTER CYLINDER	3	PARKING BRAKE SHOES	23
PARKING BRAKES	5	POWER BRAKE BOOSTER	16
POWER BRAKE BOOSTER	2	REAR DISC BRAKE CALIPER	19
REAR DISC BRAKES	4	REAR DISC BRAKE ROTOR	21
RED BRAKE WARNING LAMP	2	REAR DISC BRAKE SHOES	20
STOP LAMP SWITCH	2	REAR PARKING BRAKE CABLE	23
DIAGNOSIS AND TESTING		SPLASH SHIELD/CALIPER BRACKET/LEVER BOOT	25
BASE BRAKE SYSTEM	5	STOP LAMP SWITCH	14
BRAKE FLUID CONTAMINATION	11	DISASSEMBLY AND ASSEMBLY	
BRAKE LINE AND HOSES	11	DISC BRAKE CALIPER	28
COMBINATION VALVE	9	MASTER CYLINDER RESERVOIR	27
FRONT DISC BRAKE ROTOR	9	REAR DISC BRAKE CALIPER	30
MASTER CYLINDER/POWER BOOSTER	8	CLEANING AND INSPECTION	
PARKING BRAKE	11	CALIPER	32
REAR DISC BRAKE ROTOR	10	ADJUSTMENTS	
RED BRAKE WARNING LAMP	8	PARKING BRAKE CABLE TENSIONER	32
STOP LAMP SWITCH	8	PARKING BRAKE SHOE	33
SERVICE PROCEDURES		STOP LAMP SWITCH	32
BRAKE BLEEDING	12	SPECIFICATIONS	
BRAKE FLUID LEVEL	12	BRAKE COMPONENTS	33
BRAKE LINE	13	BRAKE FLUID	33
DISC ROTOR MACHINING	13	TORQUE CHART	33
MASTER CYLINDER BLEEDING	12	SPECIAL TOOLS	
REMOVAL AND INSTALLATION		BASE BRAKES	34
BRAKE PEDAL	14		

GENERAL INFORMATION

BRAKE SYSTEM

All vehicles are equipped with power assist four-wheel disc brakes. Antilock (ABS) brakes are also standard equipment on all models.

Single piston, disc brake calipers are used front and rear. Ventilated disc brake rotors are used at the front and solid rotors are used at the rear.

Power brake assist is supplied by a vacuum operated, dual diaphragm power brake booster. The master cylinder used for all applications has an aluminum body and nylon reservoir with single filler cap.

A combination valve is used for all applications. The valve contains a pressure differential switch and a fixed rate rear brake proportioning valve.

Factory installed brake linings on all models consists of organic base material combined with metallic particles.

SERVICE WARNINGS & CAUTIONS

WARNING: DUST AND DIRT ACCUMULATING ON BRAKE PARTS DURING NORMAL USE MAY CONTAIN ASBESTOS FIBERS FROM LININGS. BREATHING EXCESSIVE CONCENTRATIONS OF ASBESTOS FIBERS CAN CAUSE SERIOUS BODILY HARM. EXERCISE CARE WHEN SERVICING BRAKE PARTS. DO NOT CLEAN BRAKE PARTS WITH COMPRESSED AIR OR BY DRY BRUSHING. USE A VACUUM CLEANER SPECIFICALLY DESIGNED FOR THE REMOVAL OF ASBESTOS FIBERS FROM BRAKE COMPONENTS. IF A SUITABLE VACUUM CLEANER IS NOT AVAILABLE, CLEANING SHOULD BE DONE WITH A WATER DAMPENED CLOTH. DO NOT SAND, OR GRIND BRAKE LINING UNLESS EQUIPMENT USED IS DESIGNED TO CONTAIN THE DUST RESIDUE. DISPOSE OF ALL RESIDUE CONTAINING ASBESTOS FIBERS IN SEALED BAGS OR CONTAINERS TO MINIMIZE EXPOSURE TO YOURSELF AND OTHERS. FOLLOW PRACTICES PRESCRIBED BY THE OCCUPATIONAL SAFETY AND HEALTH ADMINISTRATION AND THE ENVIRONMENTAL PROTECTION AGENCY FOR THE HANDLING, PROCESSING, AND DISPOSITION OF DUST OR DEBRIS THAT MAY CONTAIN ASBESTOS FIBERS.

CAUTION: Never use gasoline, kerosene, alcohol, motor oil, transmission fluid, or any fluid containing mineral oil to clean the system components. These fluids damage rubber cups and seals. Use only fresh brake fluid or Mopar brake cleaner to clean or flush brake system components. These are the only cleaning materials recommended. If system contamination is suspected, check the fluid for dirt, discoloration,

or separation into distinct layers. Also check the reservoir cap seal for distortion. Drain and flush the system with new brake fluid if contamination is suspected.

CAUTION: Use Mopar brake fluid, or an equivalent quality fluid meeting SAE/DOT standards J1703 and DOT 3. Brake fluid must be clean and free of contaminants. Use fresh fluid from sealed containers only to ensure proper antilock component operation.

CAUTION: Use Mopar multi-mileage or high temperature grease to lubricate caliper slide surfaces, drum brake pivot pins, and shoe contact points on the backing plates. Use multi-mileage grease or GE 661 or Dow 111 silicone grease on caliper bushings and slide pins to ensure proper operation.

DESCRIPTION AND OPERATION

BRAKE PEDAL

A suspended-type brake pedal is used, the pedal pivots on a shaft mounted in the pedal support bracket. The bracket is attached to the dash panel.

The brake pedal is a serviceable component. The pedal, pedal bushings, shaft and pedal bracket are all replaceable parts.

STOP LAMP SWITCH

The plunger type stop lamp switch is mounted on a bracket attached to the brake pedal support. The switch can be adjusted when necessary.

RED BRAKE WARNING LAMP

A red warning lamp is used for the service brake portion of the hydraulic system. The lamp is located in the instrument cluster. The red warning light alerts the driver if a pressure differential exists between the front and rear hydraulic systems or the parking brakes are applied.

The lamp is turned on momentarily when the ignition switch is turned to the on position. This is a self test to verify the lamp is operational.

POWER BRAKE BOOSTER

The booster assembly consists of a housing divided into separate chambers by two internal diaphragms. The outer edge of each diaphragm is attached to the booster housing. The diaphragms are connected to the booster primary push rod.

Two push rods are used in the booster. The primary push rod connects the booster to the brake

DESCRIPTION AND OPERATION (Continued)

pedal. The secondary push rod connects the booster to the master cylinder to stroke the cylinder pistons.

The atmospheric inlet valve is opened and closed by the primary push rod. Booster vacuum supply is through a hose attached to an intake manifold fitting at one end and to the booster check valve at the other. The vacuum check valve in the booster housing is a one-way device that prevents vacuum leak back.

Power assist is generated by utilizing the pressure differential between normal atmospheric pressure and a vacuum. The vacuum needed for booster operation is taken directly from the engine intake manifold. The entry point for atmospheric pressure is through a filter and inlet valve at the rear of the housing (Fig. 1).

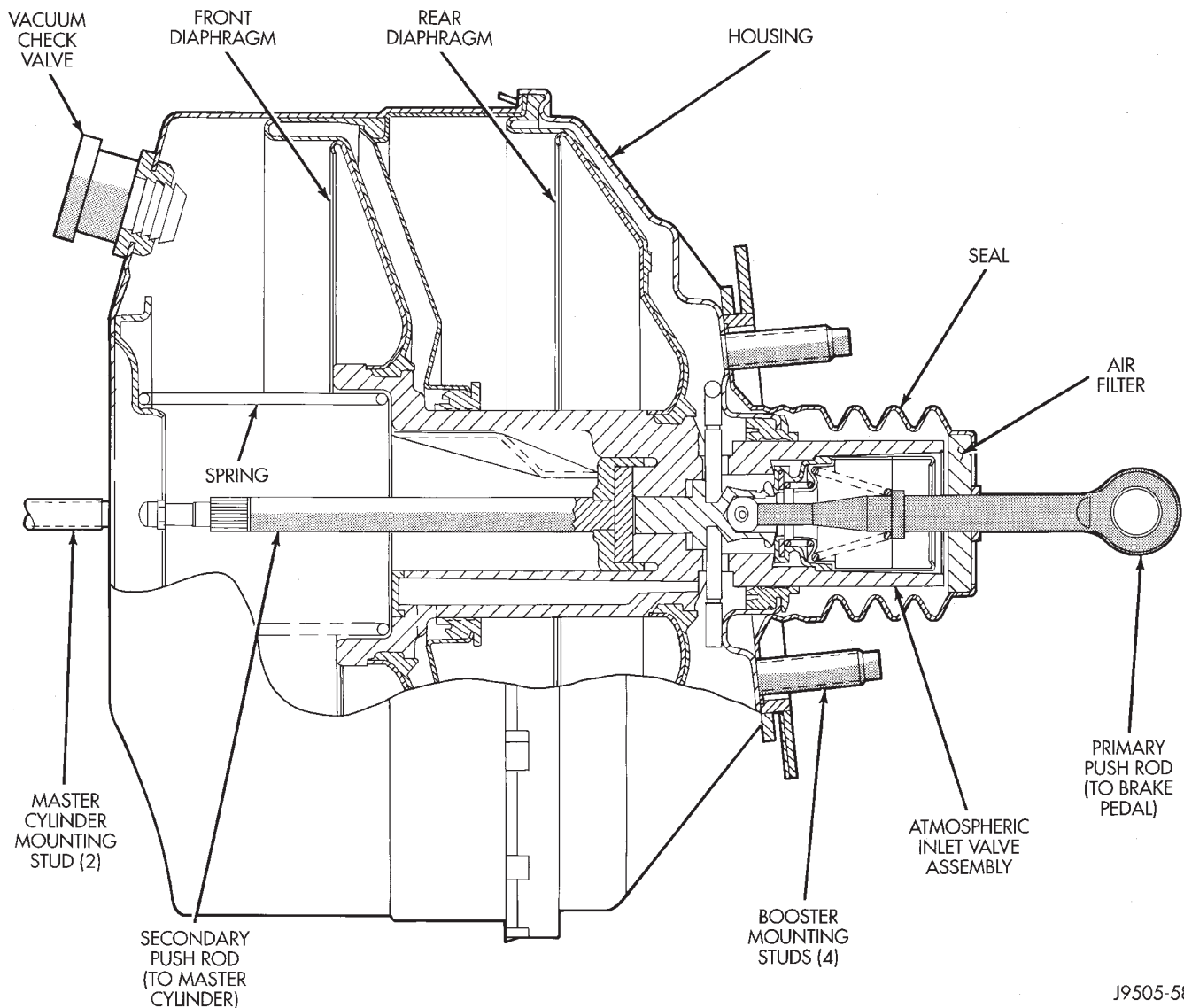
The chamber areas forward of the booster diaphragms are exposed to vacuum from the intake manifold. The chamber areas to the rear of the dia-

phragms, are exposed to normal atmospheric pressure of 101.3 kilopascals (14.7 pounds/square in.).

Brake pedal application causes the primary push rod to open the atmospheric inlet valve. This exposes the area behind the diaphragms to atmospheric pressure. The resulting pressure differential provides the extra apply force for power assist.

MASTER CYLINDER

The master cylinder has a removable nylon reservoir. The cylinder body is made of aluminum and contains a primary and secondary piston assembly. The cylinder body including the piston assemblies are not serviceable. If diagnosis indicates an internal problem with the cylinder body, it must be replaced as an assembly. The reservoir and grommets are the only replaceable parts on the master cylinder.



J9505-58

Fig. 1 Power Brake Booster—Typical

DESCRIPTION AND OPERATION (Continued)

COMBINATION VALVE

The combination valve contains a pressure differential valve and switch and a rear brake proportioning valve. The valve is not repairable and must be replaced as an assembly if diagnosis indicates this is necessary.

The pressure differential switch is connected to the brake warning light. The switch is actuated by movement of the switch valve. The switch monitors fluid pressure in the separate front/rear brake hydraulic circuits.

A decrease or loss of fluid pressure in either hydraulic circuit will cause the switch valve to shuttle to the low pressure side. Movement of the valve pushes the switch plunger upward. This action closes the switch internal contacts completing the electrical circuit to the red warning light. The switch valve will remain in an actuated position until repairs to the brake system are made.

The proportioning valve is used to balance front-rear brake action. The valve allows normal fluid flow during moderate effort brake stops. The valve only controls (meters) fluid flow during high effort brake stops.

FRONT DISC BRAKES

The calipers are a single piston type. The calipers are free to slide laterally, this allows continuous compensation for lining wear.

When the brakes are applied fluid pressure is exerted against the caliper piston. The fluid pressure is exerted equally and in all directions. This means pressure exerted against the caliper piston and within the caliper bore will be equal (Fig. 2).

Fluid pressure applied to the piston is transmitted directly to the inboard brake shoe. This forces the shoe lining against the inner surface of the disc brake rotor. At the same time, fluid pressure within the piston bore forces the caliper to slide inward on the mounting bolts. This action brings the outboard brake shoe lining into contact with the outer surface of the disc brake rotor.

In summary, fluid pressure acting simultaneously on both piston and caliper, produces a strong clamping action. When sufficient force is applied, friction will stop the rotors from turning and bring the vehicle to a stop.

Application and release of the brake pedal generates only a very slight movement of the caliper and piston. Upon release of the pedal, the caliper and piston return to a rest position. The brake shoes do not retract an appreciable distance from the rotor. In fact, clearance is usually at, or close to zero. The reasons for this are to keep road debris from getting between the rotor and lining and in wiping the rotor surface clear each revolution.

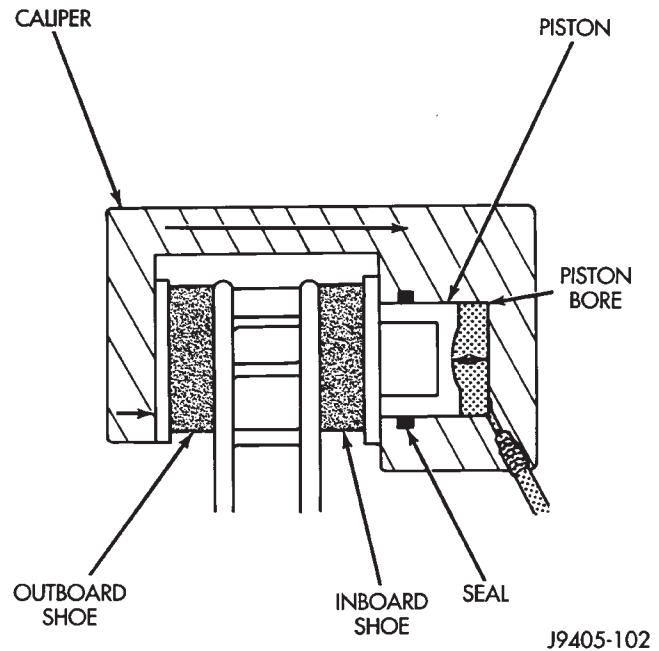


Fig. 2 Brake Caliper Operation

The caliper piston seal controls the amount of piston extension needed to compensate for normal lining wear.

During brake application, the seal is deflected outward by fluid pressure and piston movement (Fig. 3). When the brakes (and fluid pressure) are released, the seal relaxes and retracts the piston.

The amount of piston retraction is determined by brake lining wear. Generally the amount is just enough to maintain contact between the piston and inboard brake shoe.

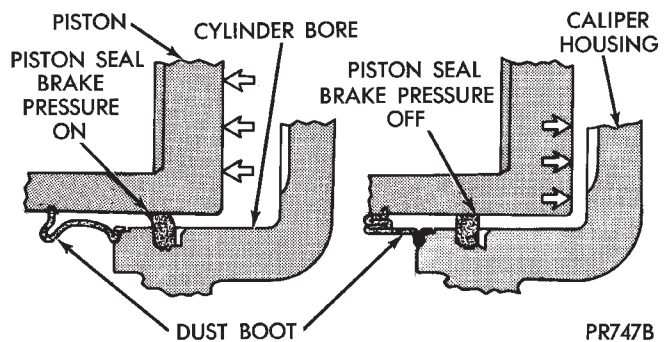


Fig. 3 Lining Wear Compensation By Piston Seal

REAR DISC BRAKES

The rear disc brakes consist of single piston floating-type calipers and solid rotors. The rear calipers are mounted in a bracket attached to the rear axle tube flange (Fig. 4). The calipers are secured to the bracket with mounting bolts. The caliper bracket also secures the rear disc brake rotor splash shield to the tube flange. The disc brake rotor has a built in brake

DESCRIPTION AND OPERATION (Continued)

drum used for the parking brakes (Fig. 5). The parking brake shoes are mounted to splash shield.

The rear disc brake shoes have an anti-rattle spring attached to the rear of the outboard shoe and a wear indicator on the inboard shoe.

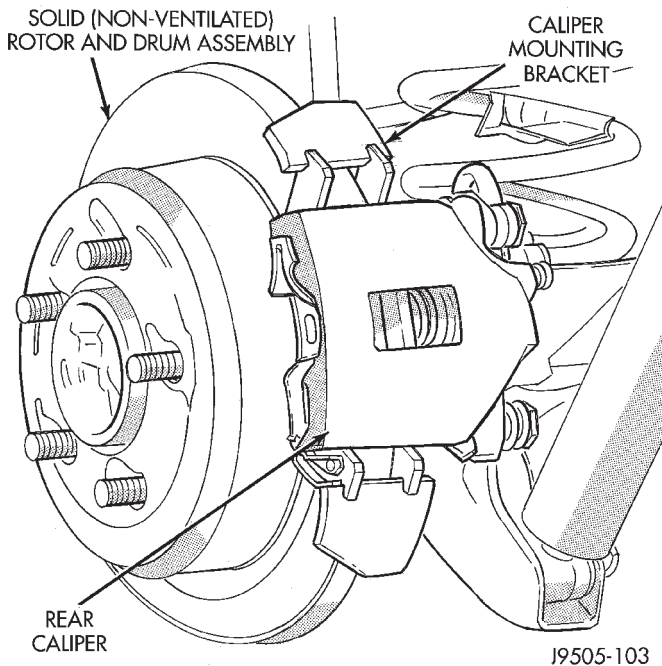


Fig. 4 Rear Disc Brake Caliper Mounting

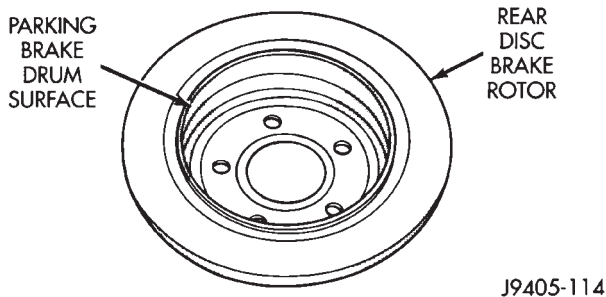


Fig. 5 Rear Disc Brake Rotor

PARKING BRAKES

The parking brakes operated by a hand lever and cable system. The front cable is connected to the hand lever and the tensioner (Fig. 6). The tensioner is attached to the equalizer mechanism used for the rear cables. The rear cables attached to the equalizer mechanism and a cam and lever mechanism, which actuates parking brake shoes.

A set of drum type brake shoes are used for parking brakes. The shoes are mounted to the rear disc brake splash shield. The parking brake drum is integrated into the rear disc brake rotor.

NOTE: Parking brake cable adjustment is controlled by a tensioner mechanism. The cable tensioner, once adjusted at the factory, will not need

further adjustment under normal circumstances. The only time a adjustment is required is when the tensioner, or cables have been replaced or disconnected.

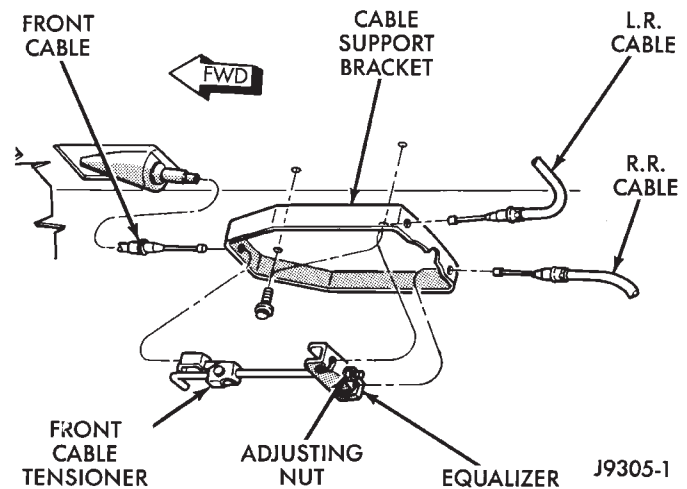


Fig. 6 Park Brake Cable Attachment

BRAKE HOSES AND LINES

Flexible rubber hose is used at both front brakes and at the rear axle junction block. Double walled steel tubing is used to connect the master cylinder to the major hydraulic braking components and then to the flexible rubber hoses.

DIAGNOSIS AND TESTING

BASE BRAKE SYSTEM

Base brake components consist of the brake shoes, calipers, wheel cylinders, brake drums, rotors, brake lines, master cylinder, booster, and parking brake components.

Brake diagnosis involves determining if the problem is related to a mechanical, hydraulic, or vacuum operated component.

The first diagnosis step is the preliminary check.

PRELIMINARY BRAKE CHECK

(1) Check condition of tires and wheels. Damaged wheels and worn, damaged, or underinflated tires can cause pull, shudder, vibration, and a condition similar to grab.

(2) If complaint was based on noise when braking, check suspension components. Jounce front and rear of vehicle and listen for noise that might be caused by loose, worn or damaged suspension or steering components.

(3) Inspect brake fluid level and condition. Note that the front disc brake reservoir fluid level will decrease in proportion to normal lining wear. **Also note that brake fluid tends to darken over time.**

DIAGNOSIS AND TESTING (Continued)

This is normal and should not be mistaken for contamination.

(a) If fluid level is abnormally low, look for evidence of leaks at calipers, wheel cylinders, brake lines, and master cylinder.

(b) If fluid appears contaminated, drain out a sample to examine. System will have to be flushed if fluid is separated into layers, or contains a substance other than brake fluid. The system seals and cups will also have to be replaced after flushing. Use clean brake fluid to flush the system.

(4) Check parking brake operation. Verify free movement and full release of cables and pedal. Also note if vehicle was being operated with parking brake partially applied.

(5) Check brake pedal operation. Verify that pedal does not bind and has adequate free play. If pedal lacks free play, check pedal and power booster for being loose or for bind condition. Do not road test until condition is corrected.

(6) Check booster vacuum check valve and hose.

(7) If components checked appear OK, road test the vehicle.

ROAD TESTING

(1) If complaint involved low brake pedal, pump pedal and note if it comes back up to normal height.

(2) Check brake pedal response with transmission in Neutral and engine running. Pedal should remain firm under constant foot pressure.

(3) During road test, make normal and firm brake stops in 25-40 mph range. Note faulty brake operation such as low pedal, hard pedal, fade, pedal pulsation, pull, grab, drag, noise, etc.

(4) Attempt to stop the vehicle with the parking brake only and note grab, drag, noise, etc.

PEDAL FALLS AWAY

A brake pedal that falls away under steady foot pressure is generally the result of a system leak. The leak point could be at a brake line, fitting, hose, or caliper/wheel cylinder. If leakage is severe, fluid will be evident at or around the leaking component.

Internal leakage (seal by-pass) in the master cylinder caused by worn or damaged piston cups, may also be the problem cause. However, internal leakage in the master cylinder may not be physically evident.

LOW PEDAL

If a low pedal is experienced, pump the pedal several times. If the pedal comes back up worn linings, rotors, drums, or rear brakes out of adjustment are the most likely causes. The proper course of action is to inspect and replace all worn component and make the proper adjustments.

SPONGY PEDAL

A spongy pedal is most often caused by air in the system. However, thin brake drums or substandard brake lines and hoses can also cause a spongy pedal. The proper course of action is to bleed the system, and replace thin drums and substandard quality brake hoses if suspected.

HARD PEDAL OR HIGH PEDAL EFFORT

A hard pedal or high pedal effort may be due to lining that is water soaked, contaminated, glazed, or badly worn. The power booster or check valve could also be faulty.

PEDAL PULSATION

Pedal pulsation is caused by components that are loose, or beyond tolerance limits.

The primary cause of pulsation are disc brake rotors with excessive lateral runout or thickness variation, or out of round brake drums. Other causes are loose wheel bearings or calipers and worn, damaged tires.

NOTE: Some pedal pulsation may be felt during ABS activation.

BRAKE DRAG

Brake drag occurs when the lining is in constant contact with the rotor or drum. Drag can occur at one wheel, all wheels, fronts only, or rears only.

Drag is a product of incomplete brake shoe release. Drag can be minor or severe enough to overheat the linings, rotors and drums.

Minor drag will usually cause slight surface charring of the lining. It can also generate hard spots in rotors and drums from the overheat-cool down process. In most cases, the rotors, drums, wheels and tires are quite warm to the touch after the vehicle is stopped.

Severe drag can char the brake lining all the way through. It can also distort and score rotors and drums to the point of replacement. The wheels, tires and brake components will be extremely hot. In severe cases, the lining may generate smoke as it chars from overheating.

Common causes of brake drag are:

- Seized or improperly adjusted parking brake cables.
- Loose/worn wheel bearing.
- Seized caliper or wheel cylinder piston.
- Caliper binding on corroded bushings or rusted slide surfaces.
- Loose caliper mounting.
- Drum brake shoes binding on worn/damaged support plates.
- Mis-assembled components.

DIAGNOSIS AND TESTING (Continued)

If brake drag occurs at all wheels, the problem may be related to a blocked master cylinder return port, or faulty power booster (binds-does not release).

BRAKE FADE

Brake fade is usually a product of overheating caused by brake drag. However, brake overheating and resulting fade can also be caused by riding the brake pedal, making repeated high deceleration stops in a short time span, or constant braking on steep mountain roads. Refer to the Brake Drag information in this section for causes.

BRAKE PULL

Front brake pull condition could result from:

- Contaminated lining in one caliper
- Seized caliper piston
- Binding caliper
- Loose caliper
- Rusty adapter/caliper slide surfaces
- Improper brake shoes
- Damaged rotor

A worn, damaged wheel bearing or suspension component are further causes of pull. A damaged front tire (bruised, ply separation) can also cause pull.

A common and frequently misdiagnosed pull condition is where direction of pull changes after a few stops. The cause is a combination of brake drag followed by fade at one of the brake units.

As the dragging brake overheats, efficiency is so reduced that fade occurs. Since the opposite brake unit is still functioning normally, its braking effect is magnified. This causes pull to switch direction in favor of the normally functioning brake unit.

An additional point when diagnosing a change in pull condition concerns brake cool down. Remember that pull will return to the original direction, if the dragging brake unit is allowed to cool down (and is not seriously damaged).

REAR BRAKE GRAB OR PULL

Rear grab or pull is usually caused by improperly adjusted or seized parking brake cables, contaminated lining, bent or binding shoes and support plates, or improperly assembled components. This is particularly true when only one rear wheel is involved. However, when both rear wheels are affected, the master cylinder or proportioning valve could be at fault.

BRAKES DO NOT HOLD AFTER DRIVING THROUGH DEEP WATER PUDDLES

This condition is generally caused by water soaked lining. If the lining is only wet, it can be dried by driving with the brakes very lightly applied for a mile or two. However, if the lining is both soaked and

dirt contaminated, cleaning and/or replacement will be necessary.

BRAKE LINING CONTAMINATION

Brake lining contamination is mostly a product of leaking calipers or wheel cylinders, worn seals, driving through deep water puddles, or lining that has become covered with grease and grit during repair. Contaminated lining should be replaced to avoid further brake problems.

WHEEL AND TIRE PROBLEMS

Some conditions attributed to brake components may actually be caused by a wheel or tire problem.

A damaged wheel can cause shudder, vibration and pull. A worn or damaged tire can also cause pull.

Severely worn tires with very little tread left can produce a grab-like condition as the tire loses and recovers traction. Flat-spotted tires can cause vibration and generate shudder during brake operation. A tire with internal damage such as a severe bruise, cut, or ply separation can cause pull and vibration.

BRAKE NOISES

Some brake noise is common with rear drum brakes and on some disc brakes during the first few stops after a vehicle has been parked overnight or stored. This is primarily due to the formation of trace corrosion (light rust) on metal surfaces. This light corrosion is typically cleared from the metal surfaces after a few brake applications causing the noise to subside.

BRAKE SQUEAK/SQUEAL

Brake squeak or squeal may be due to linings that are wet or contaminated with brake fluid, grease, or oil. Glazed linings and rotors with hard spots can also contribute to squeak. Dirt and foreign material embedded in the brake lining will also cause squeak/squeal.

A very loud squeak or squeal is frequently a sign of severely worn brake lining. If the lining has worn through to the brake shoes in spots, metal-to-metal contact occurs. If the condition is allowed to continue, rotors and drums can become so scored that replacement is necessary.

BRAKE CHATTER

Brake chatter is usually caused by loose or worn components, or glazed/burnt lining. Rotors with hard spots can also contribute to chatter. Additional causes of chatter are out-of-tolerance rotors, brake lining not securely attached to the shoes, loose wheel bearings and contaminated brake lining.

DIAGNOSIS AND TESTING (Continued)

THUMP/CLUNK NOISE

Thumping or clunk noises during braking are frequently **not** caused by brake components. In many cases, such noises are caused by loose or damaged steering, suspension, or engine components. However, calipers that bind on the slide surfaces can generate a thump or clunk noise. In addition, worn out, improperly adjusted, or improperly assembled rear brake shoes can also produce a thump noise.

STOP LAMP SWITCH

Stop lamp switch operation can be tested with an ohmmeter. The ohmmeter is used to check continuity between the pin terminals at different plunger positions (Fig. 7).

NOTE: The switch wire harness must be disconnected before testing switch continuity.

SWITCH CIRCUIT IDENTIFICATION

- Terminals 1 and 2 are for brake sensor circuit.
- Terminals 5 and 6 are for the stop lamp circuit.
- Terminals 3 and 4 are for the speed control circuit.

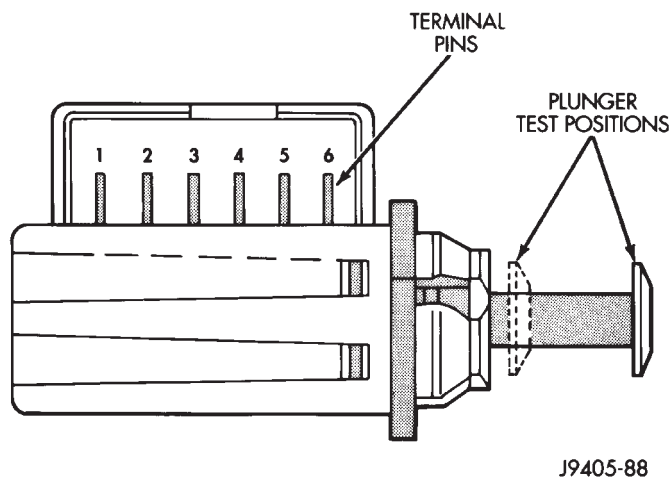


Fig. 7 Stop Lamp Switch Terminal Identification

SWITCH CONTINUITY TEST

(1) Check continuity between terminal pins 5 and 6 as follows:

(a) Pull plunger all the way out to fully extended position.

(b) Attach test leads to pins 5 and 6 and note ohmmeter reading.

(c) If continuity exists, proceed to next test. Replace switch if meter indicates lack of continuity (shorted or open).

(2) Check continuity between terminal pins 1 and 2 and pins 3 and 4 as follows:

(a) Push switch plunger inward to fully retracted position.

(b) Attach test leads to pins 1 and 2 and note ohmmeter reading.

(c) If continuity exists, switch is OK. Replace switch if meter indicates lack of continuity (switch is open).

RED BRAKE WARNING LAMP

The red warning lamp illuminates when the parking brakes are applied and when there is a leak in the front or rear wheel brake hydraulic circuit. It will also illuminate at start up as part of a bulb check.

If the light comes on, first verify that the parking brakes are fully released. Then check pedal action and fluid level. If a problem is confirmed, inspect the brake hydraulic system for leaks.

MASTER CYLINDER/POWER BOOSTER

(1) Start engine and check booster vacuum hose connections. A hissing noise indicates vacuum leak. Correct any vacuum leak before proceeding.

(2) Stop engine and shift transmission into Neutral.

(3) Pump brake pedal until all vacuum reserve in booster is depleted.

(4) Press and hold brake pedal under light foot pressure. The pedal should hold firm, if the pedal falls away master cylinder is faulty (internal leakage).

(5) Start engine and note pedal action it should fall away slightly under light foot pressure then hold firm. If no pedal action is discernible, power booster, vacuum supply, or vacuum check valve is faulty. Proceed to the POWER BOOSTER VACUUM TEST.

(6) If the POWER BOOSTER VACUUM TEST passes, rebuild booster vacuum reserve as follows: Release brake pedal. Increase engine speed to 1500 rpm, close the throttle and immediately stop turn off ignition to stop engine.

(7) Wait a minimum of 90 seconds and try brake action again. Booster should provide two or more vacuum assisted pedal applications. If vacuum assist is not provided, booster is faulty.

POWER BOOSTER VACUUM TEST

(1) Connect vacuum gauge to booster check valve with short length of hose and T-fitting (Fig. 8).

(2) Start and run engine at curb idle speed for one minute.

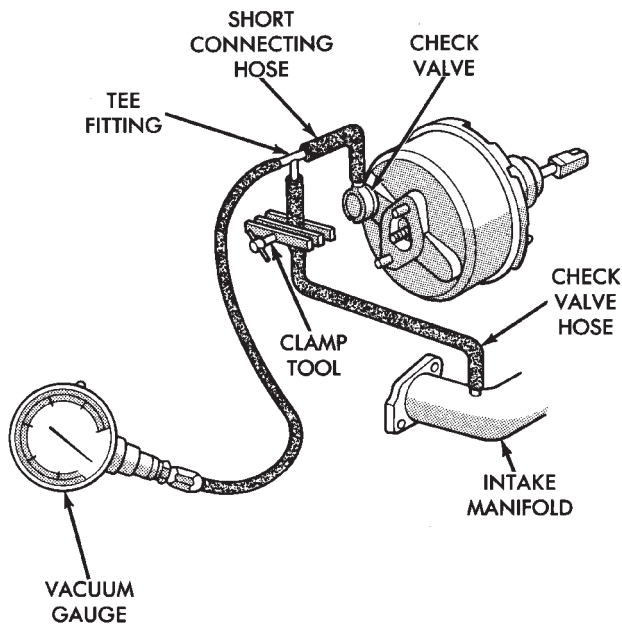
(3) Observe the vacuum supply. If vacuum supply is not adequate, repair vacuum supply.

(4) Clamp hose shut between vacuum source and check valve.

(5) Stop engine and observe vacuum gauge.

(6) If vacuum drops more than one inch HG (33 millibars) within 15 seconds, booster diaphragm or check valve is faulty.

DIAGNOSIS AND TESTING (Continued)

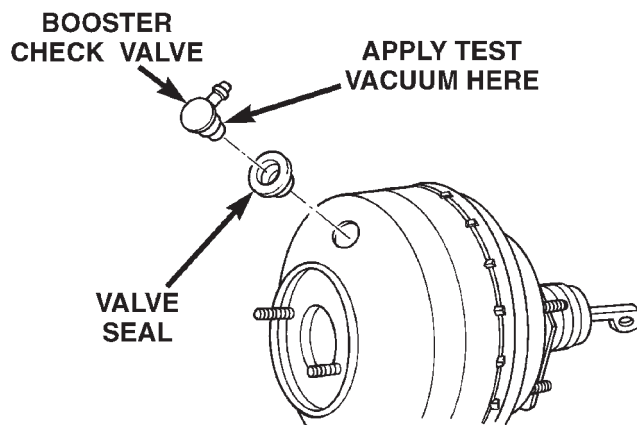


J9005-81

Fig. 8 Typical Booster Vacuum Test Connections

POWER BOOSTER CHECK VALVE TEST

- (1) Disconnect vacuum hose from check valve.
- (2) Remove check valve and valve seal from booster.
- (3) Use a hand operated vacuum pump for test.
- (4) Apply 15-20 inches vacuum at large end of check valve (Fig. 9).
- (5) Vacuum should hold steady. If gauge on pump indicates vacuum loss, check valve is faulty and should be replaced.



8031e866

Fig. 9 Vacuum Check Valve And Seal

COMBINATION VALVE

Metering Valve

Metering valve operation can be checked visually with the aid of a helper. Observe the metering valve stem while a helper applies and releases the brakes. If the valve is operating correctly, the stem will extend slightly when the brakes are applied and retract when the brakes are released. If the valve is faulty, replace the entire combination valve as an assembly.

Pressure Differential Switch

- (1) Have helper sit in drivers seat to apply brake pedal and observe red brake warning light.
- (2) Raise vehicle on hoist.
- (3) Connect bleed hose to a rear wheel cylinder and immerse hose end in container partially filled with brake fluid.
- (4) Have helper press and hold brake pedal to floor and observe warning light.
 - (a) If warning light illuminates, switch is operating correctly.
 - (b) If light fails to illuminate, check circuit fuse, bulb, and wiring. The parking brake switch can be used to aid in identifying whether or not the brake light bulb and fuse is functional. Repair or replace parts as necessary and test differential pressure switch operation again.
- (5) If warning light still does not illuminate, switch is faulty. Replace combination valve assembly, bleed brake system and verify proper switch and valve operation.

FRONT DISC BRAKE ROTOR

ROTOR MINIMUM THICKNESS

Rotor minimum usable thickness is 22.7 mm (0.89 in.). Do not resurface a rotor if machining would cause thickness to fall below this limit.

Measure rotor thickness at the center of the brake shoe contact surface. Replace the rotor if worn below minimum thickness, or if refinishing would reduce thickness below the allowable minimum.

DIAGNOSIS AND TESTING (Continued)

FRONT ROTOR THICKNESS VARIATION

Variations in rotor thickness will cause pedal pulsation, noise and shudder.

Measure rotor thickness at four to six points around the rotor face. Position the micrometer approximately 3/4 inch from the rotor outer circumference for each measurement (Fig. 10).

Thickness should not **vary** by more than 0.013 mm (0.0005 in.) from point to point on the rotor. Refinish or replace the rotor if necessary.

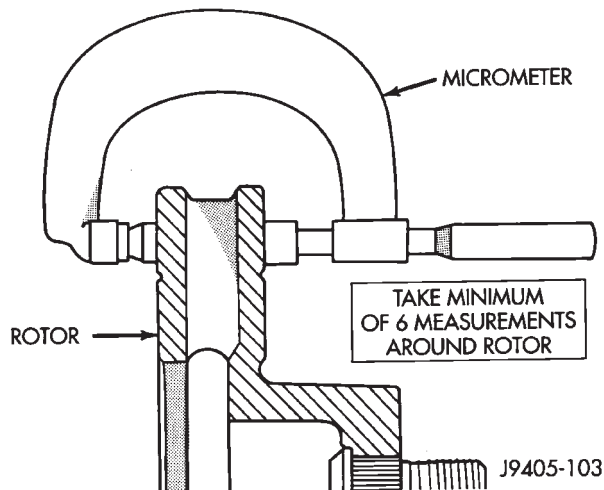


Fig. 10 Measuring Rotor Thickness Variation

FRONT ROTOR LATERAL RUNOUT

Check rotor lateral runout whenever pedal pulsation, or rapid, uneven brake lining wear has occurred.

The rotor must be securely clamped to the hub to ensure an accurate runout measurement. Secure the rotor with the wheel nuts and 4 or 5 large diameter flat washers on each stud.

Use a dial indicator to check lateral runout (Fig. 11).

Maximum allowable rotor lateral runout is 0.13 mm (0.005 in.).

REAR DISC BRAKE ROTOR

ROTOR MINIMUM THICKNESS

Minimum usable thickness of the rear disc brake rotor is 10.65 mm (0.4193 in.). The thickness specification is located on the edge of the parking brake drum section of the rotor (Fig. 12).

Never resurface a rotor if machining would cause thickness to fall below this limit.

Measure rotor thickness at the center of the brake shoe contact surface. Replace the rotor if worn below minimum thickness, or if refinishing would reduce thickness below the allowable minimum.

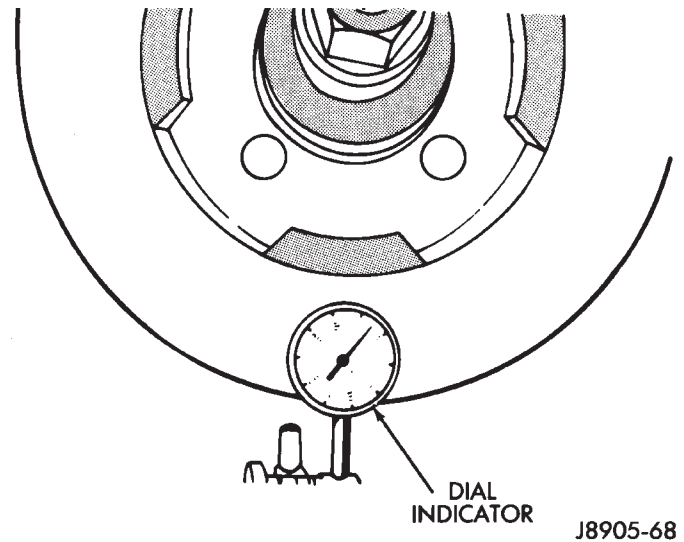


Fig. 11 Checking Rotor Lateral Runout

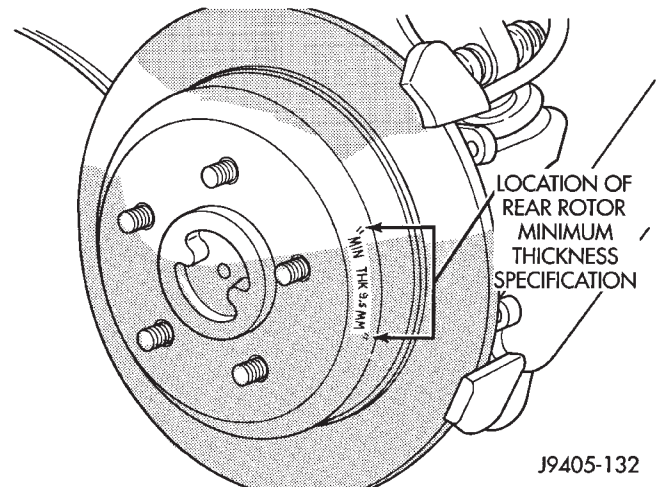


Fig. 12 Thickness Specification On Rear Rotor

REAR ROTOR THICKNESS VARIATION

Variations in rotor thickness will cause pedal pulsation, noise and shudder.

Measure rotor thickness at four to six points around the rotor face. Position the micrometer approximately 3/4 inch from the rotor outer circumference for each measurement (Fig. 10).

Thickness should not **vary** by more than 0.0254 mm (0.001 in.) from point to point on the rotor. Refinish or replace the rotor if necessary.

REAR ROTOR LATERAL RUNOUT

Check rotor lateral runout whenever diagnosis indicates pedal pulsation and rapid, uneven brake lining wear.

The rotor must be securely clamped to the hub to ensure an accurate runout measurement. Secure the rotor with the wheel nuts and 4 or 5 large diameter flat washers on each stud.

DIAGNOSIS AND TESTING (Continued)

Use a dial indicator to check lateral runout (Fig. 11). Maximum allowable lateral runout is 0.13 mm (0.005 in.).

PARKING BRAKE

NOTE: Parking brake adjustment is controlled by a cable tensioner. Once the tensioner is adjusted at the factory, it should not require further attention. However, there are two instances when adjustment will be required. The first is when a new tensioner, or cables have been installed. And the second, is when the tensioner and cables are disconnected for access to other brake components.

The parking brake switch is in circuit with the red warning lamp in the dash. The switch will cause the lamp to illuminate only when the parking brakes are applied. If the lamp remains on after parking brake release, the switch or wires are faulty, or cable tensioner adjustment is incorrect.

If the red lamp comes on while the vehicle is in motion and brake pedal height decreases, a fault has occurred in the front or rear brake hydraulic system.

In most cases, the actual cause of an improperly functioning parking brake (too loose/too tight/wont hold), can be traced to a parking brake component.

NOTE: The leading cause of improper parking brake operation, is excessive clearance between the parking brake shoes and the shoe braking surface. Excessive clearance is a result of lining and/or drum wear, drum surface machined oversize, or inoperative adjuster components.

Excessive parking brake lever travel (sometimes described as a loose lever or too loose condition), is the result of worn brake shoes, improper brake shoe adjustment, or improperly assembled brake parts.

A "too loose" condition can also be caused by inoperative or improperly assembled parking brake shoe parts.

A condition where the parking brakes do not hold, will most probably be due to a wheel brake component.

Items to look for when diagnosing a parking brake problem, are:

- Rear brake shoe wear
- Drum surface (in rear rotor) machined oversize
- Front cable not secured to lever
- Rear cable not attached to lever
- Rear cable seized
- Parking shoes reversed
- Parking brake strut not seated in shoes
- Parking brake lever not seated
- Parking brake lever bind
- Cam and lever worn or misassembled

- Adjuster screws seized
- Adjuster screws reversed

Parking brake adjustment and parts replacement procedures are described in the Parking Brake section.

BRAKE LINE AND HOSES

Flexible rubber hose is used at both front brakes and at the rear axle junction block. Inspect the hoses whenever the brake system is serviced, at every engine oil change, or whenever the vehicle is in for service.

Inspect the hoses for surface cracking, scuffing, or worn spots. Replace any brake hose immediately if the fabric casing of the hose is exposed due to cracks or abrasions.

Also check brake hose installation. Faulty installation can result in kinked, twisted hoses, or contact with the wheels and tires or other chassis components. All of these conditions can lead to scuffing, cracking and eventual failure.

The steel brake lines should be inspected periodically for evidence of corrosion, twists, kinks, leaks, or other damage. Heavily corroded lines will eventually rust through causing leaks. In any case, corroded or damaged brake lines should be replaced.

Factory replacement brake lines and hoses are recommended to ensure quality, correct length and superior fatigue life. Care should be taken to make sure that brake line and hose mating surfaces are clean and free from nicks and burrs. Also remember that right and left brake hoses are not interchangeable.

Use new copper seal washers at all caliper connections. Be sure brake line connections are properly made (not cross threaded) and tightened to recommended torque.

BRAKE FLUID CONTAMINATION

Indications of fluid contamination are swollen or deteriorated rubber parts.

Swollen rubber parts indicate the presence of petroleum in the brake fluid.

To test for contamination, put a small amount of drained brake fluid in clear glass jar. If fluid separates into layers, there is mineral oil or other fluid contamination of the brake fluid.

If brake fluid is contaminated, drain and thoroughly flush system. Replace master cylinder, proportioning valve, caliper seals, wheel cylinder seals, Antilock Brakes hydraulic unit and all hydraulic fluid hoses.

SERVICE PROCEDURES

BRAKE FLUID LEVEL

Always clean the master cylinder reservoir and cap before adding fluid. This will prevent dirt from falling in the reservoir and contaminating the brake fluid.

The reservoir has a ADD and a FULL mark on the side (Fig. 13) fill to the FULL mark.

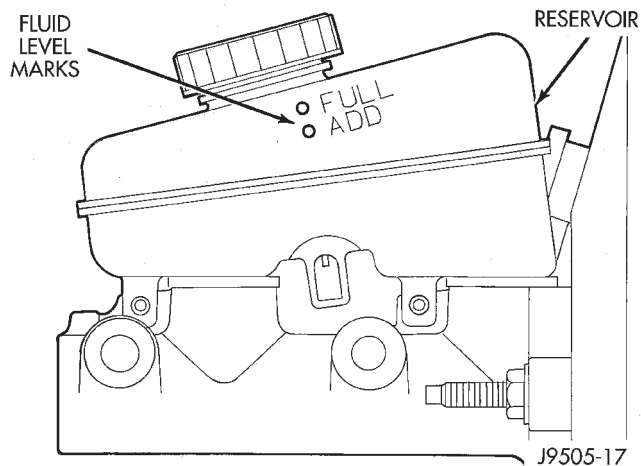


Fig. 13 Master Cylinder Fluid Level

MASTER CYLINDER BLEEDING

A new master cylinder should be bled before installation on the vehicle. Required bleeding tools include bleed tubes and a wood dowel to stroke the pistons. Bleed tubes can be fabricated from brake line.

BLEEDING PROCEDURE

- (1) Mount master cylinder in vise.
- (2) Attach bleed tubes to cylinder outlet ports. Then position each tube end into reservoir (Fig. 14).
- (3) Fill reservoir with fresh brake fluid.
- (4) Press cylinder pistons inward with wood dowel. Then release pistons and allow them to return under spring pressure. Continue bleeding operations until air bubbles are no longer visible in fluid.

BRAKE BLEEDING

Use Mopar brake fluid, or an equivalent quality fluid meeting SAE J1703-F and DOT 3 standards only. Use fresh, clean fluid from a sealed container at all times.

Do not pump the brake pedal at any time while bleeding. Air in the system will be compressed into small bubbles that are distributed throughout the hydraulic system. This will make additional bleeding operations necessary.

Do not allow the master cylinder to run out of fluid during bleed operations. An empty cylinder will allow additional air to be drawn into the system. Check the

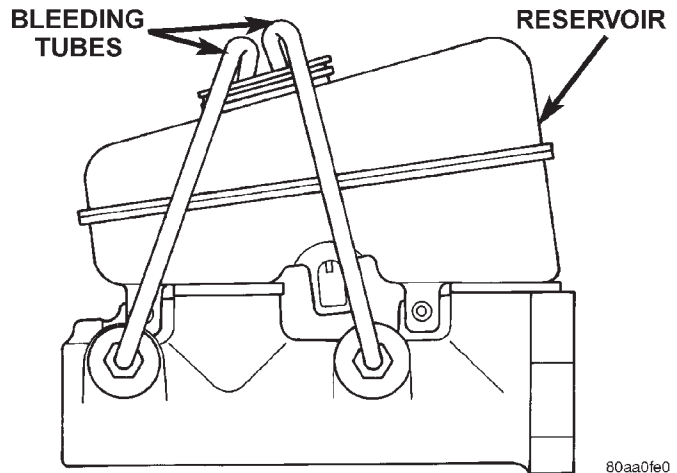


Fig. 14 Master Cylinder Bleeding—Typical

cylinder fluid level frequently and add fluid as needed.

Bleed only one brake component at a time in the following sequence:

- master cylinder
- combination valve
- right rear wheel
- left rear wheel
- right front wheel
- left front wheel

MANUAL BLEEDING

(1) Remove reservoir filler caps and fill reservoir with Mopar, or equivalent quality DOT 3 brake fluid.

(2) If calipers, or wheel cylinders were overhauled, open all caliper and wheel cylinder bleed screws. Then close each bleed screw as fluid starts to drip from it. Top off master cylinder reservoir once more before proceeding.

(3) Attach one end of bleed hose to bleed screw and insert opposite end in glass container partially filled with brake fluid (Fig. 15). Be sure end of bleed hose is immersed in fluid.

(4) Open up bleeder, then have a helper press down the brake pedal. Once the pedal is down close the bleeder. Repeat bleeding until fluid stream is clear and free of bubbles. Then move to the next wheel.

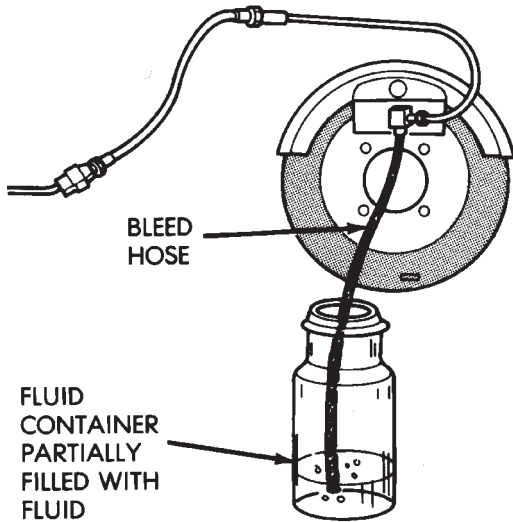
PRESSURE BLEEDING

Follow the manufacturers instructions carefully when using pressure equipment. Do not exceed the tank manufacturers pressure recommendations. Generally, a tank pressure of 15-20 psi is sufficient for bleeding.

Fill the bleeder tank with recommended fluid and purge air from the tank lines before bleeding.

Do not pressure bleed without a proper master cylinder adapter. The wrong adapter can lead to leak-

SERVICE PROCEDURES (Continued)



J8905-18

Fig. 15 Bleed Hose Setup

age, or drawing air back into the system. Use adapter provided with the equipment or Adapter 6921.

DISC ROTOR MACHINING

Rotor braking surfaces can be sanded or machined in a disc brake lathe.

The lathe must machine both sides of the rotor simultaneously with dual (two) cutter heads (Fig. 16). Equipment capable of machining only one side at a time will produce a tapered rotor.

The lathe should also be equipped with a grinder attachment or dual sanding discs for final cleanup or light refinishing (Fig. 17).

If the rotor surfaces only need minor cleanup of rust, scale, or minor scoring, use abrasive discs to clean up the rotor surfaces. However, when a rotor is scored or worn, machining with cutting tools will be required.

CAUTION: Do not machine the rotor if it will cause the rotor to fall below minimum allowable thickness.

BRAKE LINE

Mopar preformed metal brake line is recommended and preferred for all repairs. However, double-wall steel line can be used for emergency repair when factory replacement parts are not readily available.

Special, heavy duty tube bending and flaring equipment is required to prepare double wall brake line. Special bending tools are needed to avoid kinking or twisting metal brake line. In addition, special

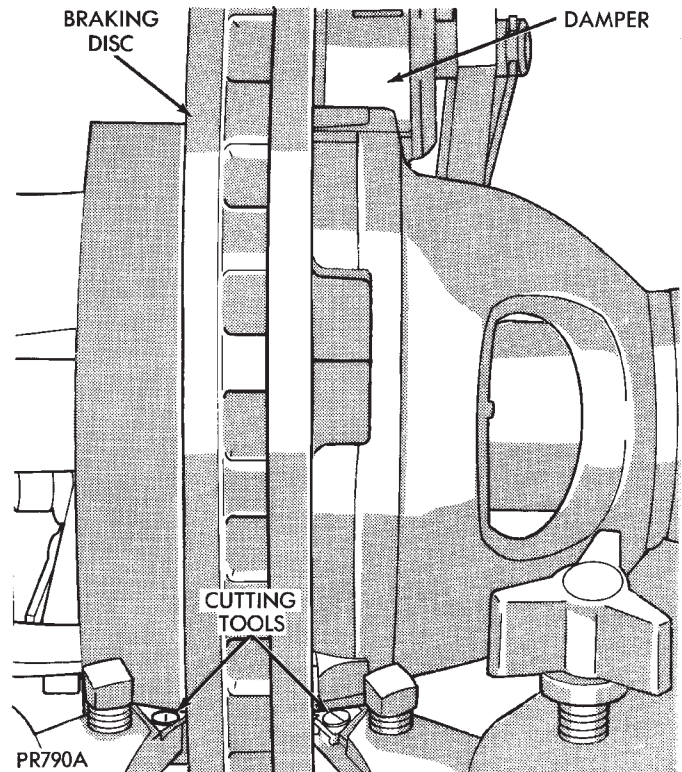


Fig. 16 Rotor Refinishing

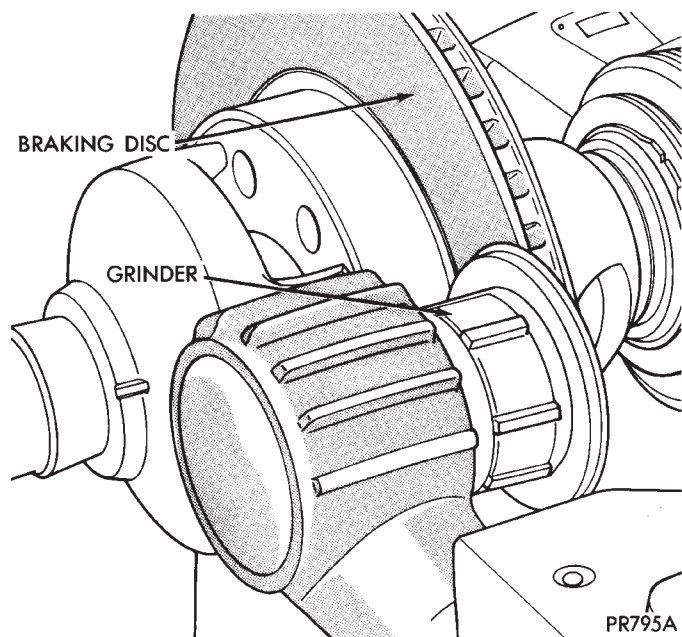


Fig. 17 Rotor Grinder

flaring tools are needed to provide the inverted-type, double flare required on metal brake lines.

FLARING PROCEDURE

- (1) Cut off damaged tube with Tubing Cutter.
- (2) Ream cut edges of tubing to ensure proper flare.

SERVICE PROCEDURES (Continued)

(3) Install replacement tube nut on section of tube to be repaired.

(4) Insert tube in flaring tool. Center tube in area between vertical posts.

(5) Place gauge form over the end of the tube.

(6) Push tubing through flaring tool jaws until tube contacts recessed notch in gauge that matches tube diameter.

(7) Squeeze flaring tool jaws to lock tubing in place.

(8) Insert plug on gauge in the tube. Then swing compression disc over gauge and center tapered flaring screw in recess of compression disc (Fig. 18).

(9) Tighten tool handle until plug gauge is seated on jaws of flaring tool. This will start the inverted flare.

(10) Remove the plug gauge and complete the inverted flare.

(11) Remove the flaring tools and verify that the inverted flare is correct.

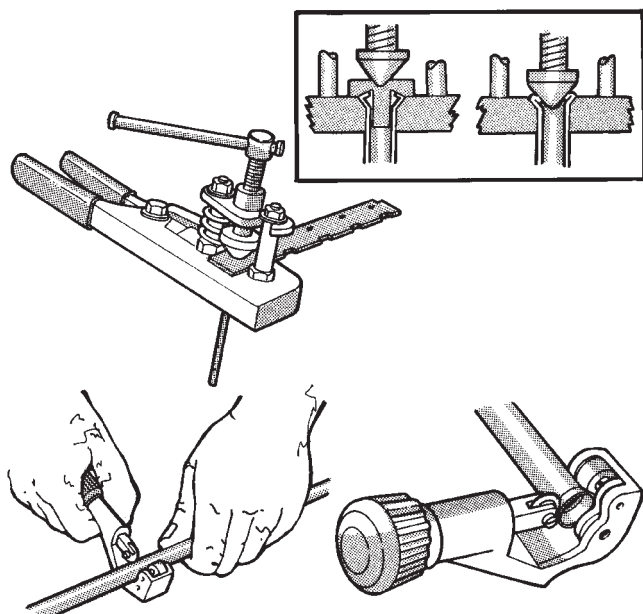


Fig. 18 Inverted Flare Tools

RH222

REMOVAL AND INSTALLATION

STOP LAMP SWITCH

REMOVAL

(1) Remove steering column cover and lower trim panel for switch access (if necessary).

(2) Press brake pedal downward to fully applied position.

(3) Rotate switch approximately 30° in counter-clockwise direction to unlock switch retainer. Then pull switch rearward and out of bracket.

(4) Disconnect switch wire harness and remove switch from vehicle (Fig. 19).

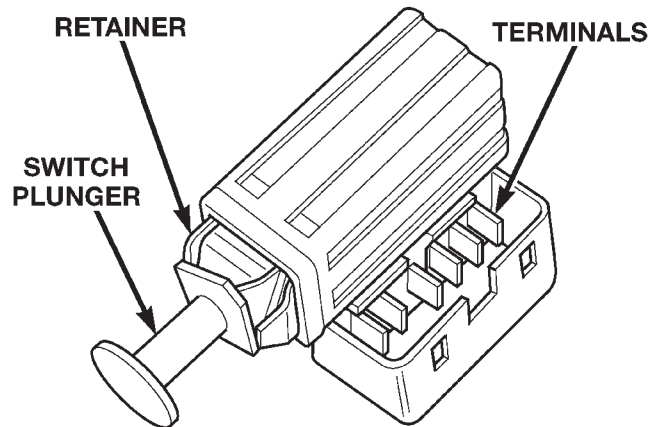


Fig. 19 Stop Lamp Switch

80aafb2f

INSTALLATION

(1) Pull switch plunger all the way out to fully extended position.

(2) Connect harness wires to switch.

(3) Press and hold brake pedal in applied position.

(4) Install switch as follows: Align tab on switch with notch in switch bracket. Then insert switch in bracket and turn it clockwise about 30° to lock it in place.

(5) Release brake pedal. Then pull pedal fully rearward. Pedal will set plunger to correct position as pedal pushes plunger into switch body. Switch will make ratcheting sound as it self adjusts.

BRAKE PEDAL

REMOVAL

(1) Remove knee blocker cover and knee blocker, refer to Group 8E Instrument Panel Systems.

(2) Remove retainer clip and washers attaching booster push rod to pedal pin (Fig. 20).

(3) Remove nut securing pedal shaft in support bracket.

(4) Slide pedal shaft outward for clearance and remove brake pedal.

(5) Remove pedal bushings if they are to be replaced.

INSTALLATION

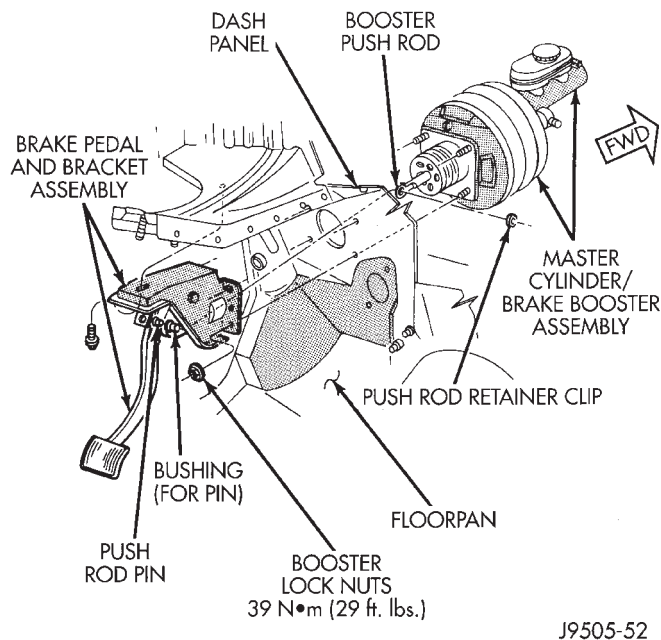
(1) Install new bushings in pedal. Lubricate bushings and pivot pin with Mopar multi-mileage grease.

(2) Position pedal, sleeve and spacer(s) in bracket and install pedal shaft in support and through pedal.

(3) Install new nut on pedal shaft. **Shaft nut is specially formed and should not be reused. Be sure to install new nut to secure shaft.**

(4) Tighten pedal shaft nut to 27 N·m (20 ft. lbs.) on models with manual transmission. Tighten nut to 35 N·m (26 ft. lbs.) on models with automatic transmission.

REMOVAL AND INSTALLATION (Continued)



J9505-52

Fig. 20 Brake Pedal Mounting

(5) Lubricate bushings and pedal pin with Mopar multi-mileage grease.

(6) Install bushing on pedal pin if removed (Fig. 20).

(7) Install booster push rod on pedal pin. Secure push rod to pedal with retainer ring and washers.

(8) Install knee blocker cover and knee blocker, refer to Group 8E Instrument Panel Systems.

(9) Check and adjust stop lamp switch if necessary.

COMBINATION VALVE

REMOVAL

(1) Remove brake lines that connect master cylinder to combination valve (Fig. 21).

(2) Disconnect brake lines that connect combination valve to HCU.

(3) Disconnect wire from combination valve switch terminal. Be careful when separating wire connector as lock tabs are easily damaged if not fully disengaged.

(4) Remove nuts attaching combination valve bracket to booster studs and valve bracket off booster studs (Fig. 22).

INSTALLATION

(1) Position valve bracket on booster studs and tighten bracket attaching nuts to 18 N•m (155 in. lbs.).

(2) Align and start all four brake line fittings in combination valve by hand to avoid cross threading. Then tighten fittings just enough to prevent leakage.

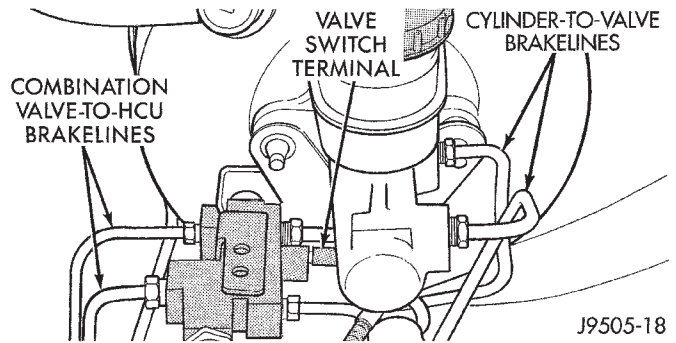


Fig. 21 Combination Valve Brake Lines

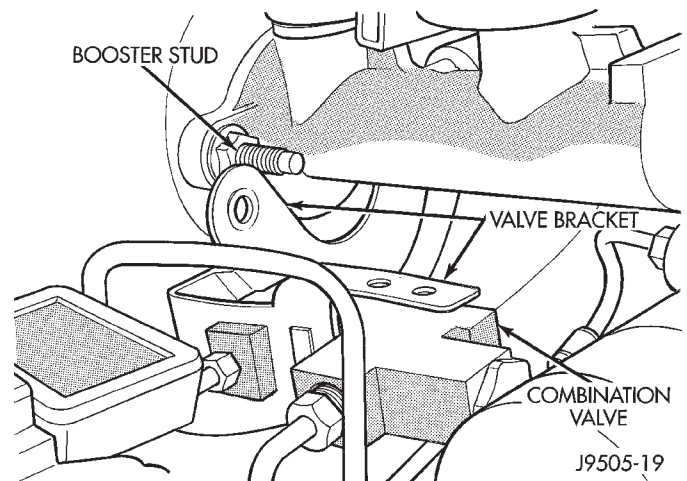


Fig. 22 Combination Valve Bracket

(3) Connect wire to differential pressure switch in combination valve.

(4) Tighten brake line fittings at master cylinder just enough to prevent leakage.

(5) Bleed brakes.

MASTER CYLINDER

REMOVAL

(1) Remove brake lines from master cylinder.

(2) Remove combination valve.

(3) Remove nuts that attach master cylinder to booster studs (Fig. 23). **Retain nuts as they are special locking types.**

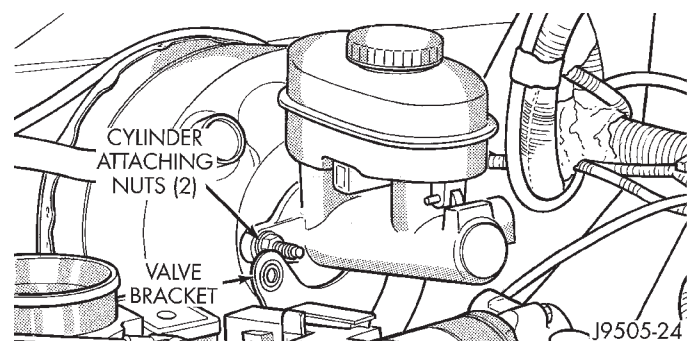


Fig. 23 Master Cylinder Mounting

REMOVAL AND INSTALLATION (Continued)

- (4) Remove master cylinder from booster.

INSTALLATION

NOTE: Bleed new master cylinder on bench before installation, refer to Service Procedures.

- (1) Remove protective cover from end of primary piston.
- (2) Bleed master cylinder.
- (3) Slide master cylinder onto booster studs. Align booster push rod in cylinder primary piston and seat cylinder against booster.
- (4) Install master cylinder mounting nuts and tighten nuts to 18 N·m (155 in. lbs.). **Use original or factory replacement nuts only.**
- (5) Install combination valve and tighten mounting nuts to 18 N·m (155 in. lbs.).
- (6) Install brake lines that connect master cylinder to combination valve.
- (7) Fill and bleed brake system.

POWER BRAKE BOOSTER

REMOVAL

- (1) Remove air filter housing.
- (2) Remove master cylinder, combination valve, and HCU.
- (3) Disconnect vacuum hose at booster check valve (Fig. 24).

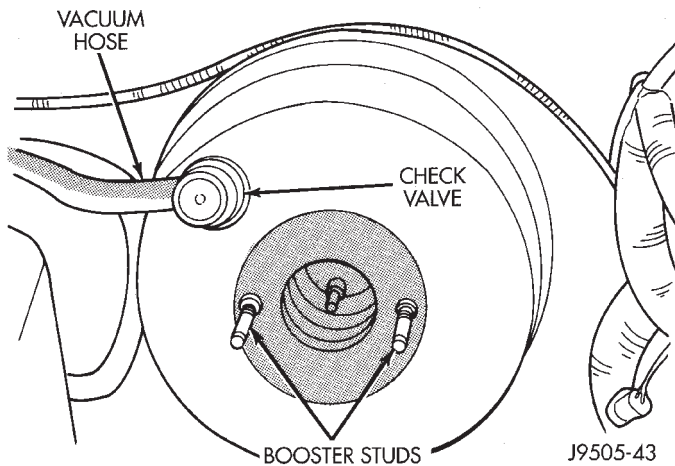


Fig. 24 Booster Check Valve And Hose

- (4) Remove retainer clip that holds booster push rod on pedal pin (Fig. 25). Then slide push rod off pin.
- (5) Remove four nuts that attach booster to dash panel.
- (6) In engine compartment, slide booster forward, tilt it upward slightly, and remove it from engine compartment.

- (7) If booster will be stored on bench for any length of time, cover booster with shop towels to prevent dust entry and place short lengths of rubber hose over booster studs to protect threads.

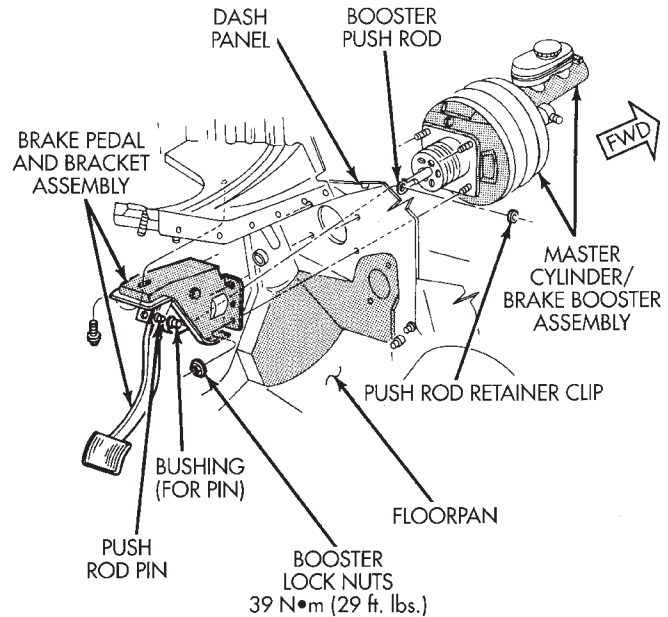


Fig. 25 Power Brake Booster Mounting

INSTALLATION

- (1) Check condition of grommet that secures check valve in booster. Replace grommet if cut, torn, or loose (no longer secures valve tightly).
- (2) Wipe booster mounting surface of dash panel clean with shop towel.
- (3) Align and position booster on engine compartment side of dash panel.
- (4) Inside passenger compartment:
 - (a) Lubricate pedal pin and bushing with Mopar multi-mileage grease.
 - (b) Install booster attaching nuts on studs. Tighten attaching nuts to 39 N·m (29 ft. lbs.).
 - (c) Slide booster push rod on pedal pin. Then secure rod to pin with retainer clip.
- (5) In engine compartment, attach vacuum hose to booster check valve.
- (6) Install master cylinder, combination valve, and HCU. Refer to procedures in this section.
- (7) Bleed brakes. Refer to section covering brake bleeding.
- (8) Install engine air cleaner and hoses.

DISC BRAKE CALIPER

REMOVAL

- (1) Raise and support vehicle.
- (2) Remove front wheel and tire assembly.

REMOVAL AND INSTALLATION (Continued)

(3) Drain small amount of fluid from master cylinder brake reservoir with suction gun.

(4) Bottom caliper piston in bore with C-clamp. Position clamp screw on outboard brake shoe and clamp frame on rear of caliper (Fig. 26). **Do not allow clamp screw to bear directly on outboard shoe retainer spring. Use wood or metal spacer between shoe and clamp screw.**

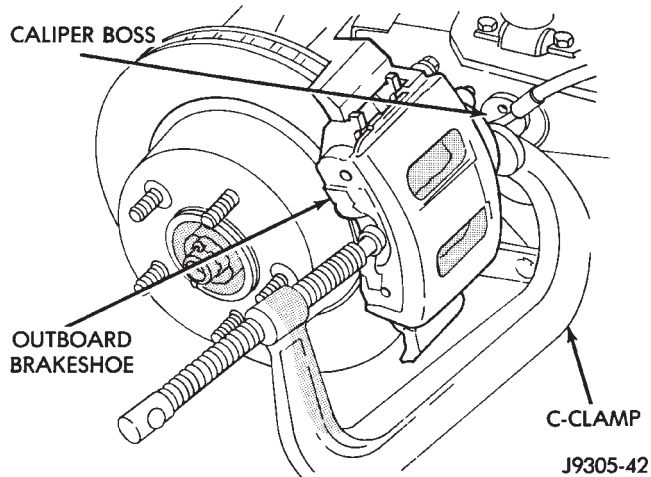


Fig. 26 Bottoming Caliper Piston With C-Clamp

(5) Remove brake hose mounting bolt and discard washers (Fig. 27).

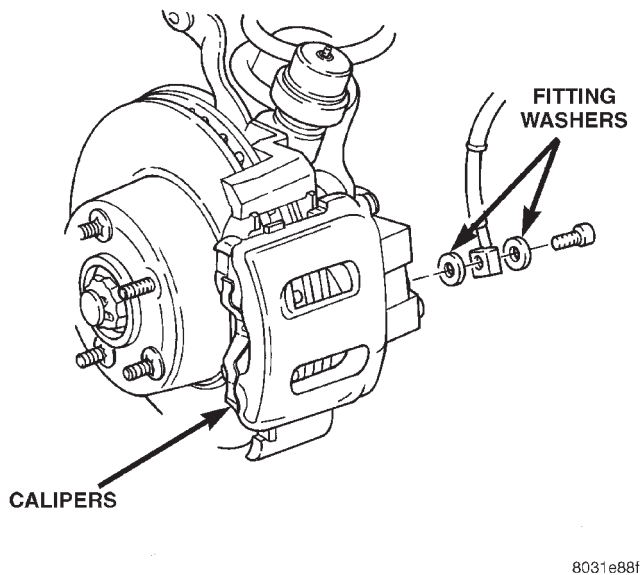


Fig. 27 Brake Hose And Bolt

- (6) Remove caliper mounting bolts (Fig. 28).
- (7) Tilt top of caliper outward with pry tool if necessary (Fig. 29) and remove caliper.
- (8) Remove caliper from vehicle.

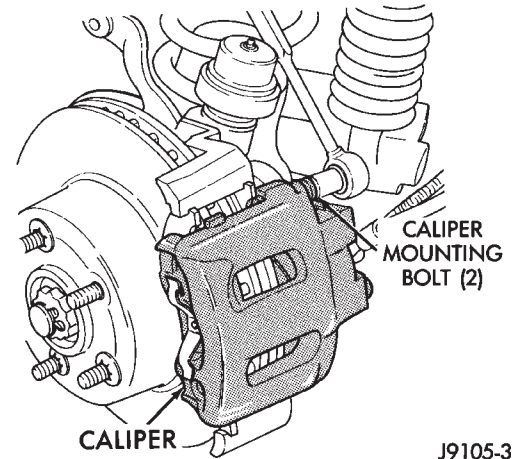


Fig. 28 Caliper Mounting Bolts

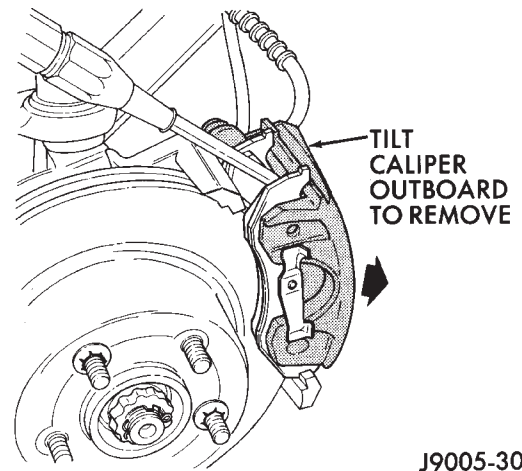


Fig. 29 Caliper Removal

INSTALLATION

(1) Clean brake shoe mounting ledges with wire brush and apply light coat of Mopar multi-mileage grease to surfaces (Fig. 30).

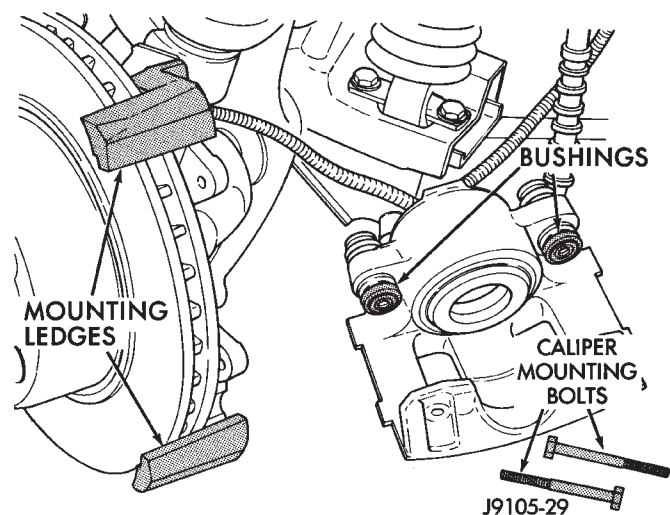
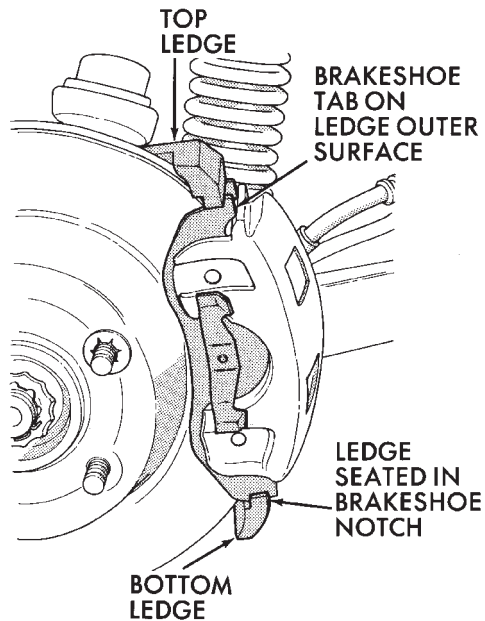


Fig. 30 Caliper Lubrication Points

REMOVAL AND INSTALLATION (Continued)

(2) Connect brake hose to caliper with **new** washer on both sides of hose fitting. Do not tighten fitting bolt completely at this time.

(3) Install caliper by position notches at lower end of brake shoes on bottom mounting ledge. Then rotate caliper over rotor and seat notches at upper end of shoes on top mounting ledge (Fig. 31).

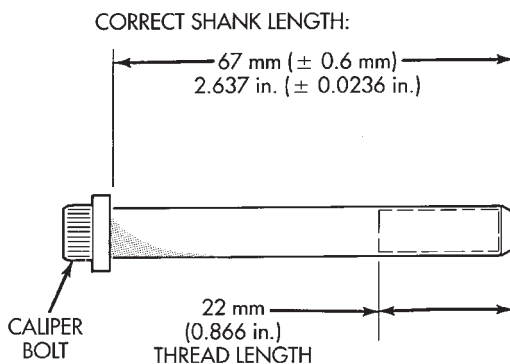


J9005-35

Fig. 31 Caliper Installation

(4) Coat caliper mounting bolts with silicone grease. Then install and tighten bolts to 15 N·m (11 ft. lbs.).

CAUTION: If new caliper bolts are being installed, or if the original reason for repair was a drag/pull condition, check caliper bolt length before proceeding. Bolts must not have a shank length greater than 67.6 mm (2.66 in.) (Fig. 32).



J9405-154

Fig. 32 Mounting Bolt Dimensions

(5) Tighten brake hose fitting bolt to 31 N·m (23 ft. lbs.).

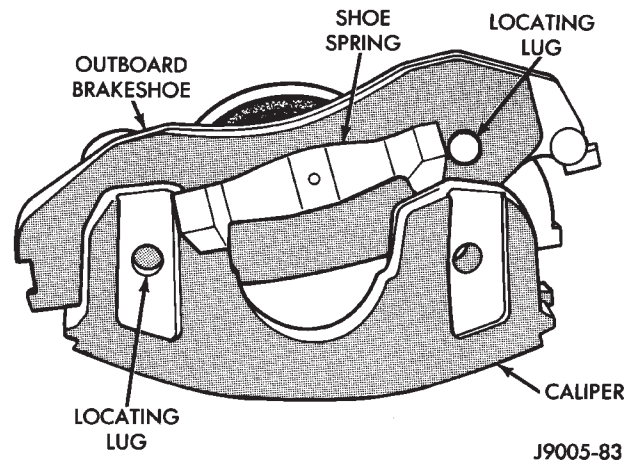
CAUTION: Insure the brake hose is not twisted or kinked and clear of all steering and suspension components.

- (6) Install wheel and tire assembly.
- (7) Remove support and lower vehicle.
- (8) Pump brake pedal until caliper pistons and brake shoes are seated.
- (9) Fill master cylinder and bleed brake system.

DISC BRAKE SHOES

REMOVAL

- (1) Raise and support vehicle.
- (2) Remove wheel and tire assembly.
- (3) Remove caliper.
- (4) Pressing one end of outboard shoe inward to disengage shoe lug. Then rotate shoe upward until retainer spring clears caliper. Press opposite end of shoe inward to disengage shoe lug and rotate shoe up and out of caliper (Fig. 33).



J9005-83

Fig. 33 Outboard Brake Shoe Removal

(5) Grasp ends of inboard shoe and tilt shoe outward to release springs from caliper piston (Fig. 34) and remove shoe from caliper.

NOTE: If original brake shoes will be used, keep them in sets left and right. They are not interchangeable.

(6) Secure caliper to nearby suspension part with wire. **Do not allow brake hose to support caliper weight.**

(7) Wipe caliper off with shop rags or towels.

CAUTION: Do not use compressed air, this can unseat dust boot and force dirt into piston bore.

REMOVAL AND INSTALLATION (Continued)

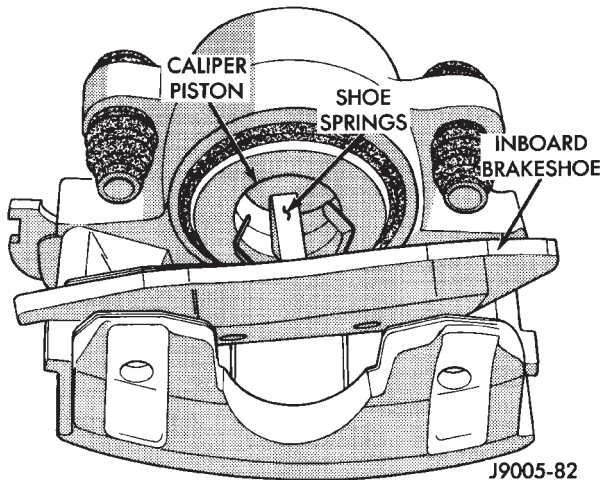


Fig. 34 Inboard Brake Shoe Removal

INSTALLATION

- (1) Install inboard shoe in caliper and verify shoe retaining is fully seated into the piston.
- (2) Starting one end of outboard shoe in caliper and rotating shoe downward into place. Verify shoe locating lugs and shoe spring are seated.
- (3) Install caliper.
- (4) Install wheel and tire assembly.
- (5) Remove support and lower vehicle.
- (6) Pump brake pedal until caliper pistons and brake shoes are seated.
- (7) Top off brake fluid level if necessary.

DISC BRAKE ROTOR

REMOVAL

- (1) Remove wheel and tire assembly.
- (2) Remove caliper.
- (3) Remove retainers securing rotor to hub studs (Fig. 35).
- (4) Remove rotor from hub.
- (5) If rotor shield requires service, remove front hub and bearing assembly.

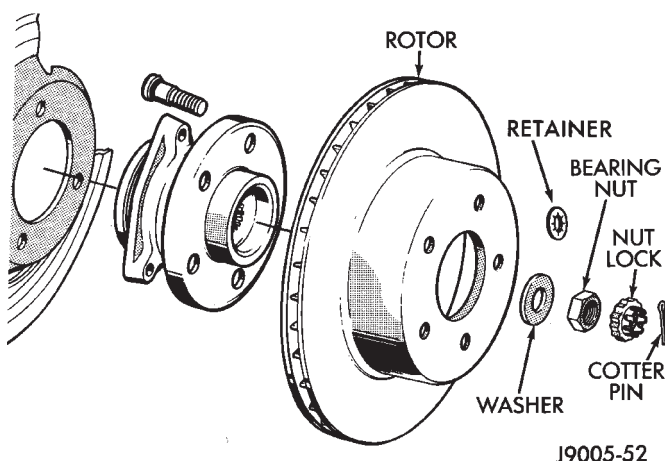


Fig. 35 Rotor & Hub

INSTALLATION

- (1) If new rotor is being installed, remove protective coating from rotor surfaces with carburetor cleaner.
- (2) Install rotor on hub.
- (3) Install caliper.
- (4) Install wheel and tire assembly.

REAR DISC BRAKE CALIPER

REMOVAL

- (1) Raise vehicle and remove tire and wheel assemblies.
- (2) Press caliper piston into caliper bore with C-clamp (Fig. 36).
- (3) Remove caliper mounting bolts (Fig. 37).
- (4) Rotate caliper rearward by hand or with pry tool. Then rotate caliper and brake shoes off ledges of mounting bracket.
- (5) Remove caliper fitting bolt and disconnect rear brake hose at caliper. Discard metal washers on fitting bolt. Washers should be replaced and not reused.
- (6) Remove caliper from vehicle.

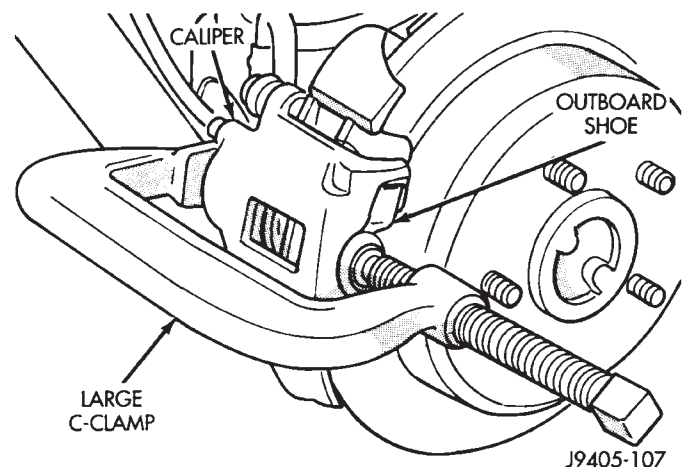


Fig. 36 Bottoming Caliper Piston

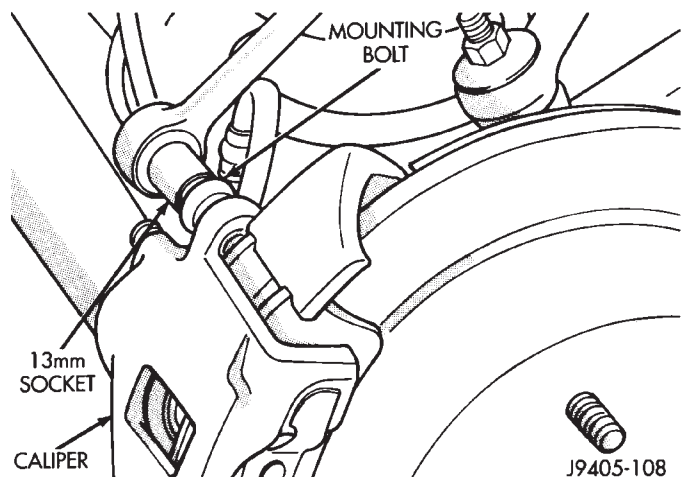
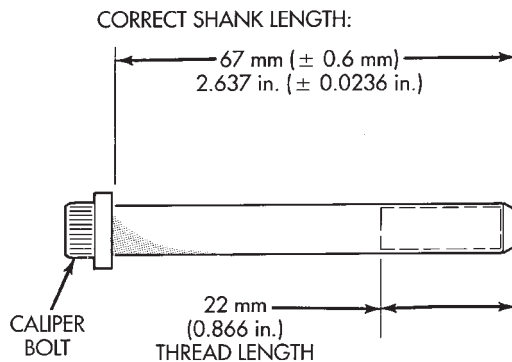


Fig. 37 Caliper Mounting Bolt

REMOVAL AND INSTALLATION (Continued)**INSTALLATION**

- (1) Verify that brake shoes are correctly positioned in caliper.
- (2) Position caliper over rotor and into bracket. Be sure brake shoe tabs are properly seated on mounting bracket ledges.
- (3) Connect rear brake hose to caliper. Use new washers on hose fitting and tighten hose fitting bolt to 24-38 N·m (216-336 in. lbs.).
- (4) Check brake hose position before proceeding. Verify that hose is not twisted, kinked, or touching any suspension components.

CAUTION: Check caliper bolt length before proceeding (Fig. 38). If the bolts have a shank length greater than 67.6 mm (2.66 in.), they will contact the inboard brake shoe causing a partial apply condition.



J9405-154

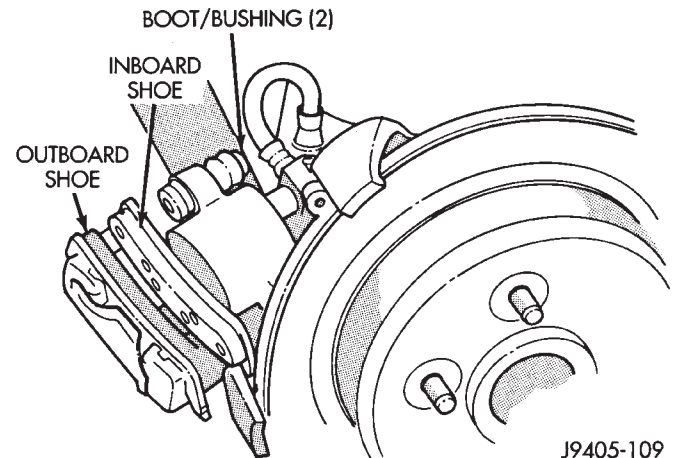
Fig. 38 Caliper Mounting Bolt Dimensions

- (5) Lubricate and install caliper mounting bolts. Start bolts by hand then tighten bolts to 10-20 N·m (7-15 ft. lbs.).
- (6) Fill and bleed brake system.
- (7) Install wheel and tire assemblies.
- (8) Lower vehicle.

REAR DISC BRAKE SHOES**REMOVAL**

- (1) Raise and support vehicle.
- (2) Remove rear wheel and tire assemblies.
- (3) Press caliper piston back into caliper bore with large Cackling.

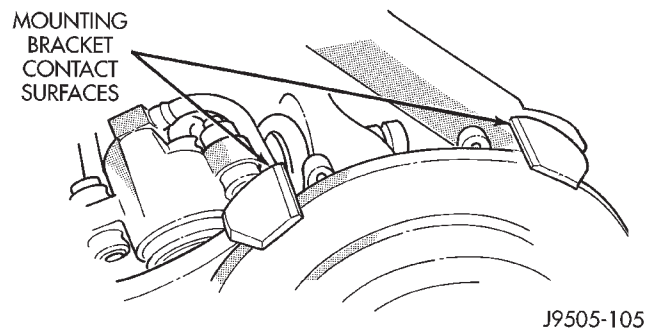
- (4) Remove caliper mounting bolts.
- (5) Rotate caliper rearward and off rotor (Fig. 39). Support caliper with wire attached to nearby suspension component. **Do not allow brake hose to support caliper weight.**
- (6) Press one corner of outboard shoe inward then pry shoe upward with suitable tool and rotate shoe out of caliper.
- (7) Pry inboard shoe outward until shoe retainers come out of caliper piston. Then remove shoe from caliper.

**Fig. 39 Rear Caliper**

- (8) Inspect caliper mounting bolt bushings and boots. Replace boots if torn or cut. Replace bushings, or bolts if either exhibits wear, or heavy corrosion.

INSTALLATION

- (1) Clean brake shoe contact surfaces of caliper mounting bracket (Fig. 40). Use wire brush or emery cloth.

**Fig. 40 Brake Shoe Contact Surfaces**

REMOVAL AND INSTALLATION (Continued)

- (2) Install brake shoes in caliper.
- (3) Install caliper over rotor and into mounting bracket.
- (4) Verify that brake shoe lugs are properly seated on caliper mounting bracket (Fig. 41). Be sure springs on outboard shoes are also seated against bracket.

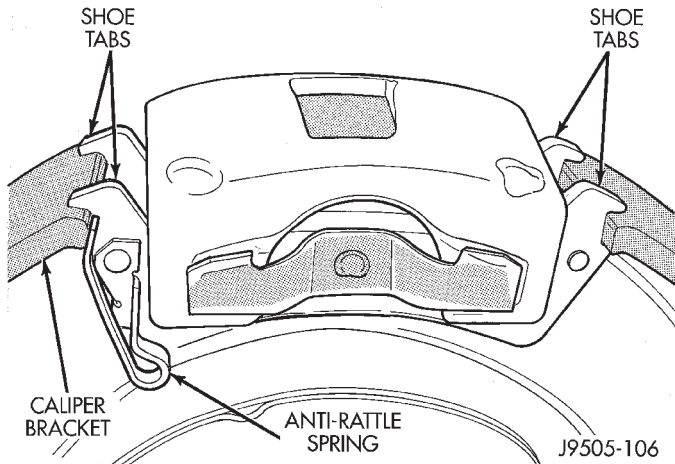


Fig. 41 Correct Brake Shoe Position

- (5) Verify hose must not be twisted or kinked.
- (6) Lubricate and install caliper mounting bolts and tighten to 10-20 N·m (7-15 ft. lbs.).
- (7) Install wheel and tire assemblies.
- (8) Turn ignition On and run HCU pump until it shuts off. Then pump brake pedal until shoes are seated and indicator lights go out.
- (9) Top off brake fluid level if necessary. Use Mopar brake fluid or equivalent meeting SAD Djawa and DOT 3 standards only.

REAR DISC BRAKE ROTOR

REMOVAL

- (1) Raise vehicle.
- (2) Remove wheel and tire assembly.
- (3) Remove caliper.
- (4) Remove access plug from splash shield and back off parking brake shoes by rotating adjuster screw star wheel with brake tool (Fig. 42). At driver side rear wheel, rotate adjuster screw star wheel clockwise to back off shoes. At passenger side wheel, rotate star wheel in counterclockwise direction. Direction of rotation is while looking from rear to front of vehicle.

(5) If rotor and/or axle hub contact surfaces are heavily rusted, apply rust penetrant oil to rotor and axle hub and through spaces around wheel studs.

(6) Remove push nuts securing rotor to axle shaft studs.

(7) Work rotor off axle hub and studs. Use plastic or rawhide mallet to loosen rotor if necessary.

(8) Clean and inspect rotor braking surfaces. Refinish, or replace rotor if necessary.

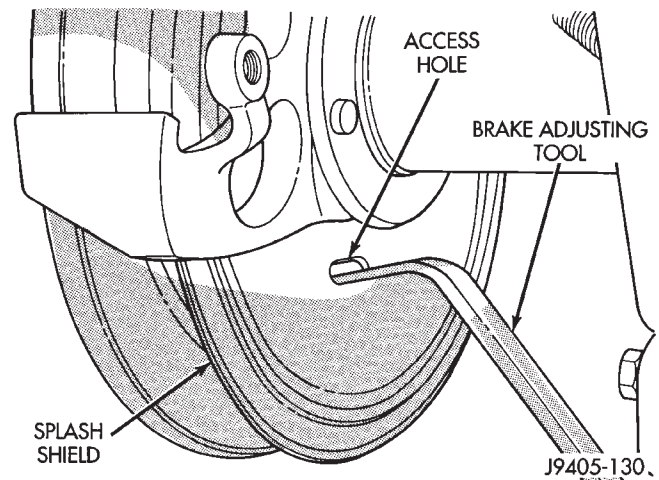


Fig. 42 Backing Off Parking Brake Shoes

INSTALLATION

- (1) Clean axle hub and hub bore in rotor with wire brush, or emery cloth.
- (2) Install rotor on axle hub.
- (3) Install disc brake caliper.
- (4) Install wheel and tire assembly and lower vehicle.
- (5) Adjust parking brake shoes. Use brake tool to rotate adjuster screw star wheel. Tighten shoes until light drag is created. Then back off shoes about 1/2 to one turn of star wheel.
- (6) Install plug in splash shield access hole.
- (7) Pump brake pedal to seat caliper piston and brake shoes. Do not move vehicle until firm brake pedal is obtained.

PARKING BRAKE HAND LEVER

REMOVAL

- (1) Release parking brakes.
- (2) Disconnect battery negative cable.
- (3) Raise vehicle on hoist.

REMOVAL AND INSTALLATION (Continued)

(4) Remove front cable adjusting nut and disengage cable tensioner from equalizer. Then remove front cable from tensioner (Fig. 43).

(5) Disengage front cable from insert and insert from floorpan.

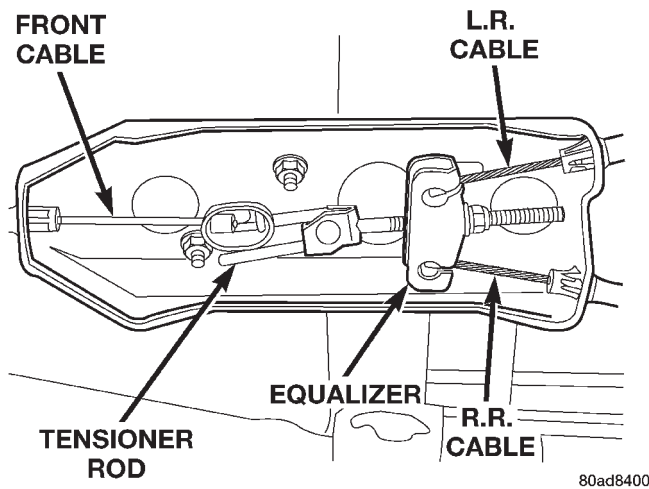
(6) Lower vehicle.

(7) Remove center console, refer to Group 23 Body.

(8) Disconnect parking brake switch wiring connector.

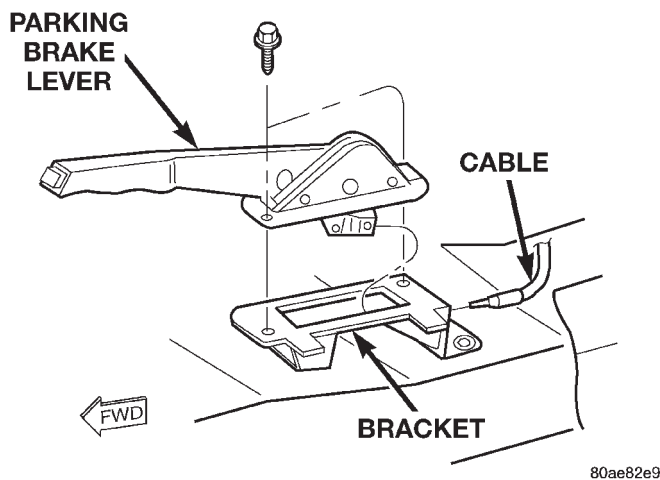
(9) Remove screws attaching parking brake lever to bracket and lift lever upward for access to front cable (Fig. 44).

(10) Disengage front cable from parking brake lever and remove lever assembly from vehicle.



80ad8400

Fig. 43 Park Brake Cable Attachment



80ae82e9

Fig. 44 Parking Brake Lever Mounting

INSTALLATION

- (1) Connect front cable to lever assembly.
- (2) Seat front cable in floor pan.
- (3) Install lever assembly on mounting bracket.
- (4) Connect parking brake switch wire connector.
- (5) Install parking lever cover.
- (6) Install center console, refer to Group 23 Body.

(7) Raise vehicle.

(8) Assemble front cable, cable tensioner and cable bracket.

(9) Adjust parking brake front cable.

(10) Lower vehicle.

(11) Connect battery negative cable.

FRONT PARKING BRAKE CABLE**REMOVAL**

(1) Release parking brakes.

(2) Disconnect battery negative cable and raise vehicle on hoist.

(3) Remove front cable adjusting nut and disengage cable tensioner from equalizer. Then remove front cable from tensioner (Fig. 45).

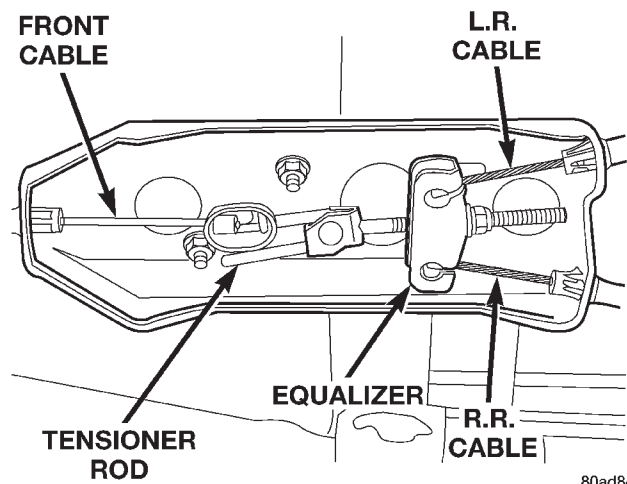
(4) Disengage front cable from insert and insert from floorpan.

(5) Lower vehicle.

(6) Remove console, refer to Group 23 Body.

(7) Remove park brake lever.

(8) Disconnect front cable from parking brake lever and remove cable.



80ad8400

Fig. 45 Park Brake Cable Attachment

INSTALLATION

(1) Connect front cable to lever assembly.

(2) Seat front cable in floor pan.

(3) Install lever assembly.

(4) Install console.

(5) Raise vehicle.

(6) Assemble front cable, cable tensioner and equalizer.

(7) Adjust parking brake system if new cable, or tensioner has been installed, or if tensioner mechanism has been loosened, or removed for access to other components. Refer to Parking Brake Adjustment procedure in this section.

(8) Lower vehicle.

(9) Connect battery negative cable.

REMOVAL AND INSTALLATION (Continued)

REAR PARKING BRAKE CABLE

REMOVAL

- (1) Raise vehicle and loosen adjusting nut at equalizer to provide slack in rear cables.
- (2) Disengage cable at equalizer. Then disengage cable from body and chassis clips and retainers.
- (3) Slide cable eyelet off actuating lever (Fig. 46).
- (4) Compress retainer securing cable in bracket attached to caliper bracket. Then remove cable from bracket.

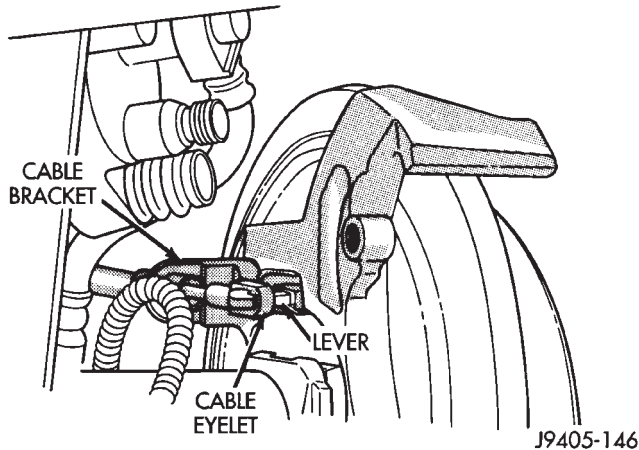


Fig. 46 Rear Cable Attachment

INSTALLATION

- (1) Install cable eyelet on lever. Be sure eyelet is seated in lever notch.
- (2) Seat cable retainer in caliper bracket.
- (3) Route cable up to cable tensioner and equalizer. Then connect cable to equalizer.
- (4) Check cable routing. Be sure cable is secured in body and chassis clips and retainers. Also be sure cable is not twisted, kinked or touching any rotating components.
- (5) Adjust parking brake.

PARKING BRAKE SHOES

REMOVAL

- (1) Raise vehicle.
- (2) Remove rear wheel and tire assembly.
- (3) Remove caliper. **Do not allow brake hose to support caliper weight. Support caliper with wire attached to suspension component.**
- (4) Remove rubber access plug from back of rear disc brake splash shield.
- (5) Retract parking brake shoes with brake adjuster tool (Fig. 47). Position tool at top of star wheel and rotate wheel downward in clockwise direction (while facing front of vehicle).

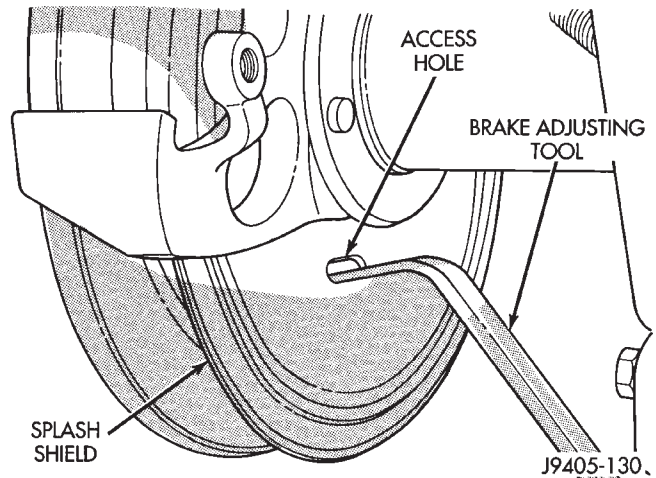


Fig. 47 Retracting Parking Brake Shoes

- (6) Remove rotor from axle hub flange.
- (7) Remove shoe hold-down clips and pins (Fig. 48). Clip is held in place by pin which fits in clip notch. To remove clip, first push clip ends together with thumb or forefinger. Next, slide clip upward until head of pin clears narrow part of notch. Then remove pin and clip.

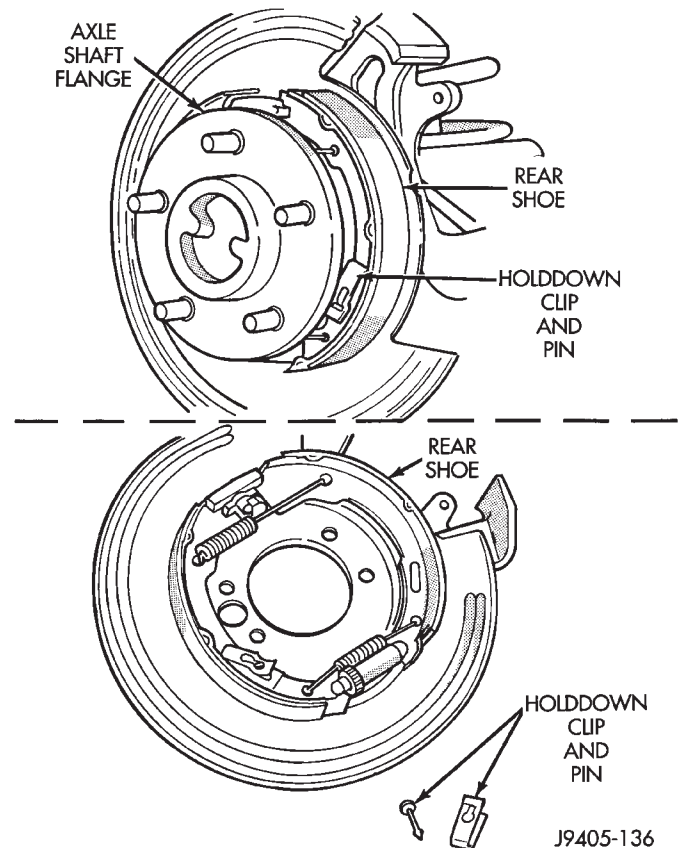


Fig. 48 Hold-Down Clip And Pin

REMOVAL AND INSTALLATION (Continued)

(8) Remove upper and lower springs from shoes with needle nose pliers (Fig. 49).

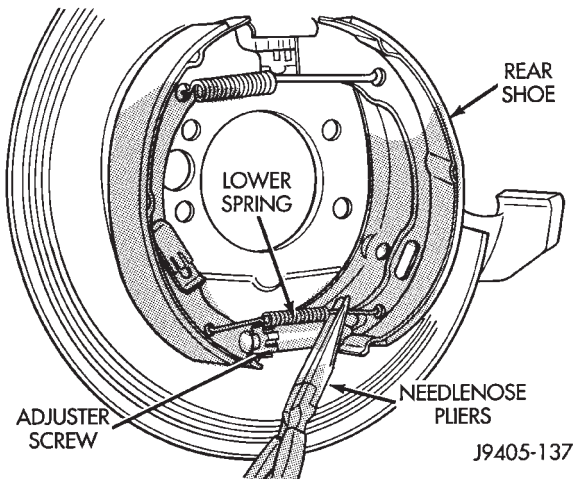


Fig. 49 Lower Spring

(9) Tilt shoes outward and remove adjuster screw. **Note adjuster screw position for installation reference.**

(10) Inspect condition of all brake components. Replace parts if bent, damaged or worn.

(11) Clean and inspect condition of adjuster screw assembly. Replace assembly if worn, or damaged.

INSTALLATION

(1) Lubricate shoe contact pads and cam and lever with Mopar multi-mileage grease (Fig. 50).

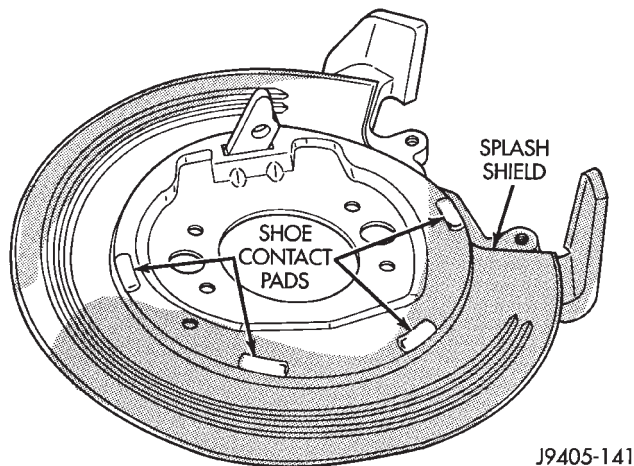


Fig. 50 Shoe Contact Pads

(2) Install shoes on splash shield with hold down clips and pins. Be sure shoes are properly engaged in caliper bracket and cam.

(3) Install adjuster screw assembly. Be sure notched ends of screw assembly are properly seated on shoes and that star wheel is aligned with access hole in shield.

(4) Install shoe upper and lower return spring. Needle nose pliers can be used to connect spring to

each shoe. Operate lever to verify that shoes expand and retract properly.

(5) Install rotor and caliper.

(6) Adjust parking brake shoes.

(7) Install wheel and tire assembly.

(8) Adjust parking brake cable tensioner.

(9) Lower vehicle and verify correct parking brake operation.

PARKING BRAKE CAM AND LEVER**REMOVAL**

(1) Raise vehicle.

(2) Remove wheel and tire assembly.

(3) Remove brake caliper and rotor.

(4) Remove parking brake shoes.

(5) Move lever forward and disconnect parking brake rear cable from lever.

(6) Pull lever forward through boot. Disengage cam from lever and remove cam (Fig. 51).

(7) Remove lever.

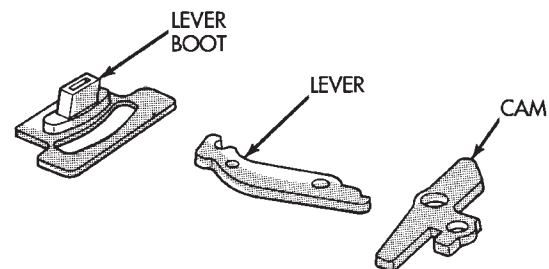


Fig. 51 Cam, Lever And Boot

INSTALLATION

NOTE: The cams are reversible and can be used on either wheel. The levers are NOT reversible. They are marked R and L and the lever notch (for the cable eyelet), must face rearward on both sides.

(1) Lubricate replacement lever with silicone grease. Then insert lever part way through boot. Be sure lever notch is facing rearward.

(2) Engage cam in lever. Then simultaneously slide cam into place on splash shield and work lever through boot (Fig. 52).

(3) Install parking brake shoes.

(4) Verify correct installation of cam and lever by pulling lever toward front of vehicle. Cam should expand both brake shoes as lever is pulled forward.

(5) Install rotor and adjust parking brake shoes.

(6) Connect rear cable to lever. Be sure cable eyelet is securely attached in lever notch.

(7) Install brake caliper and wheel and tire assembly.

(8) Lower vehicle and verify correct parking brake operation.

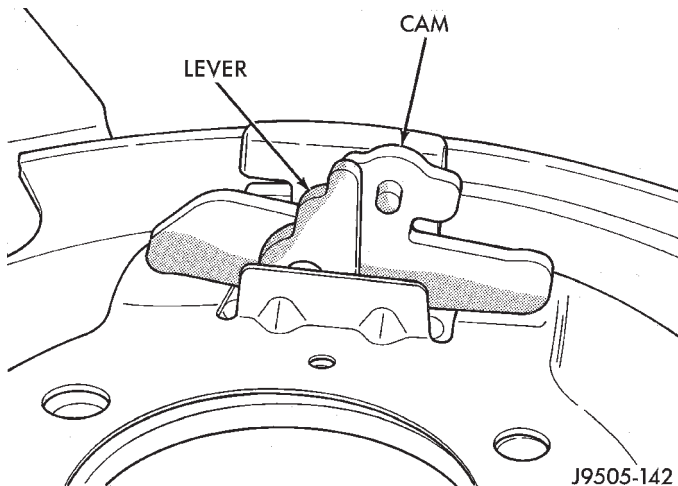
REMOVAL AND INSTALLATION (Continued)

Fig. 52 Cam And Lever

J9505-142

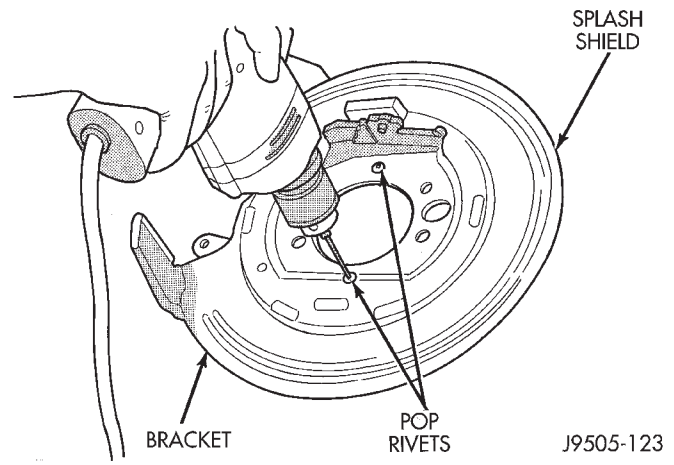


Fig. 53 Drilling Out Splash Shield Rivets

J9505-123

SPLASH SHIELD/CALIPER BRACKET/LEVER BOOT**REMOVAL**

- (1) Raise vehicle and remove wheel and tire assembly.
- (2) Remove caliper bolts and lift caliper off rotor and bracket. Suspend caliper from chassis or suspension component with wire.
- (3) Retract parking brake shoes and remove rotor.
- (4) Remove axle shaft, refer to Group 3 Differential and Driveline.
- (5) Remove parking brake shoes from splash shield.
- (6) Remove nuts attaching splash shield and caliper bracket to axle tube flange.
- (7) Remove splash shield and caliper bracket from axle studs and work lever out of rear cable eyelet.
- (8) Mark position of splash shield and bracket for assembly reference. Use paint or scribe to mark parts.
- (9) Drill out rivets that retain splash shield to caliper bracket (Fig. 53). If rivet heads did not come completely off after drilling, remove remaining pieces with small chisel.

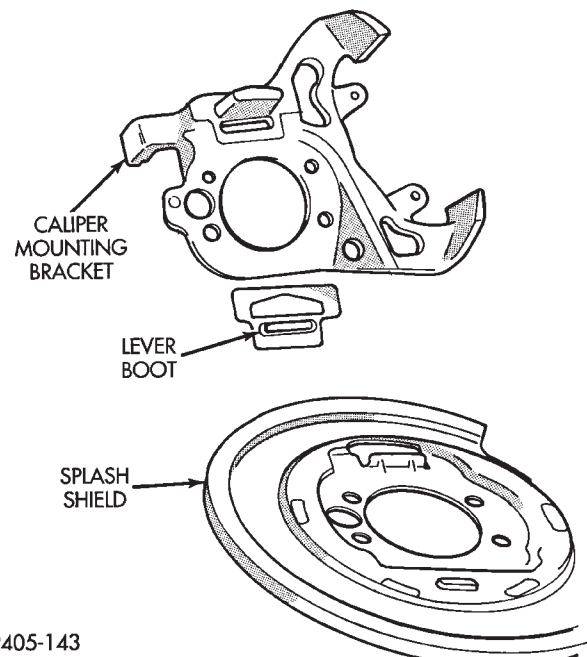
NOTE: Rivets do not have to be replaced. They are used to keep the boot in place during manufacturing.

- (10) Then remove cam and lever from splash shield and bracket. Note position of cam and lever for installation reference.

- (11) Separate splash shield and caliper bracket. Then remove lever boot from bracket (Fig. 54).

INSTALLATION

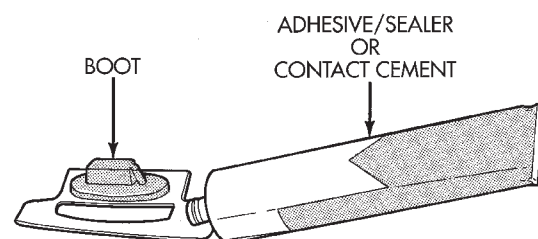
- (1) If original bracket and shield will be reused, clean them with Mopar carb and brake cleaner. Also clean shoe contact pad surfaces of shield with 400 grit paper. Lubricate pad surfaces with light coat of Mopar multi-mileage grease.



J9405-143

Fig. 54 Caliper Bracket, Splash Shield And Lever Boot

- (2) Apply thin coat of contact cement or silicone adhesive to new lever boot and to boot mounting area of caliper bracket (Fig. 55). Apply adhesive to areas where boot and bracket contact one another. Adhesive is needed to hold boot in position when splash shield is attached to bracket.



J9505-124

Fig. 55 Applying Adhesive To Parking Brake Lever Boot

REMOVAL AND INSTALLATION (Continued)

(3) Install new boot on caliper bracket. Metal retainer part of boot fits over ledge on caliper as shown (Fig. 56). Rubber part of boot extends through rear opening in bracket. Allow adhesive on boot and bracket to set up for a minute or two before proceeding.

CAUTION: If the boot is not installed properly, it will prevent the shield from seating squarely on the bracket. This will cock the shield causing it to rub against the rotor after installation.

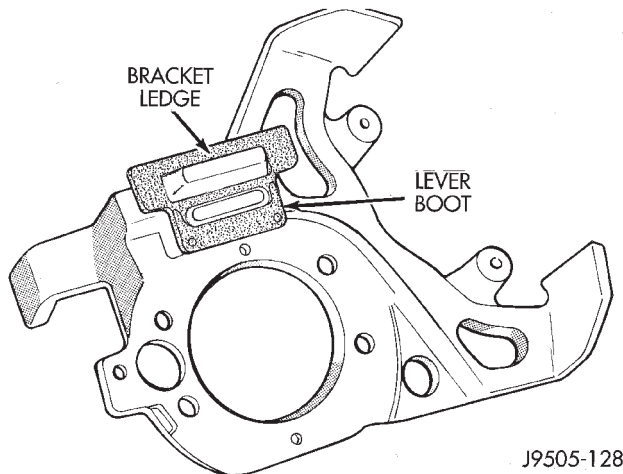


Fig. 56 Lever Boot Installation

(4) Position splash shield on caliper bracket. Then carefully install shield and bracket assembly on axle tube flange studs.

(5) Apply Mopar Lock N' Seal or Loctite® 242 to the axle tube stud nuts. Then install and tighten nuts to 43-61 N·m (32-45 ft. lbs.).

(6) Assemble and install cam and lever. Push lever through boot and seat cam between lip on shield and ledge on bracket (Fig. 57). Then engage lever in cable eyelet. Be sure cable notch in lever is facing rearward. Remove and reposition cam and lever if necessary.

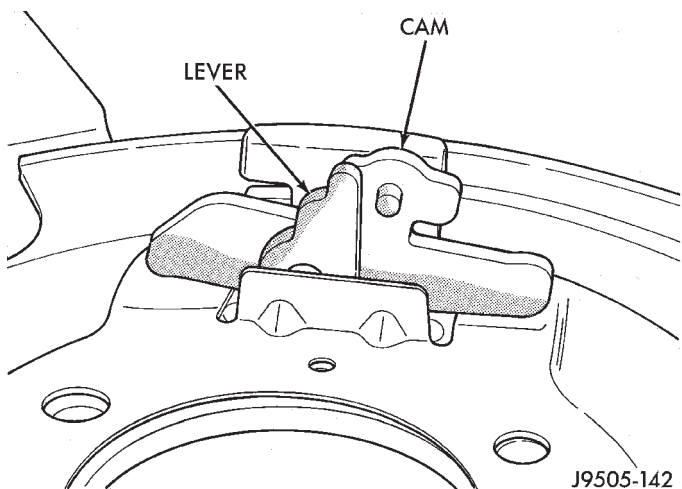


Fig. 57 Cam And Lever Installation

(7) Install parking brake shoes on splash shield. Verify positioning of cam and lever, shoes, springs and hold-down clips and pins (Fig. 58).

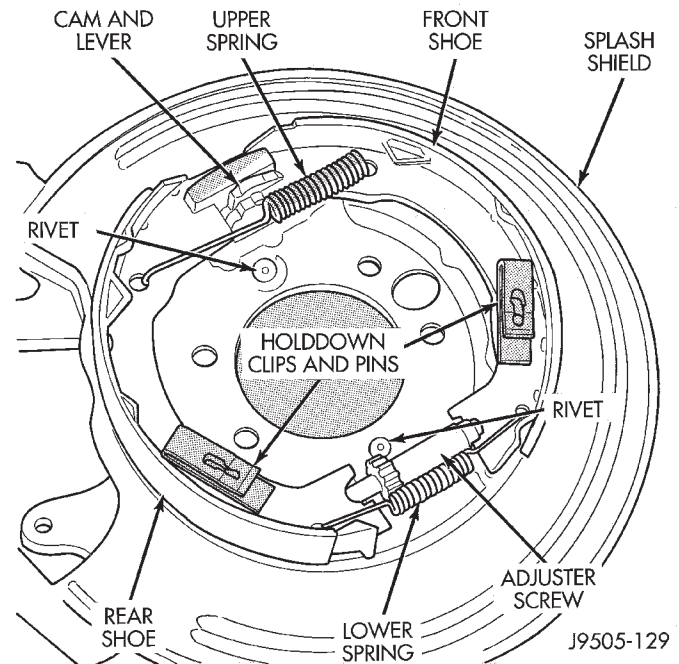


Fig. 58 Parking Brake Shoes Mounted On Shield

(8) Verify correct positioning of caliper bracket and shield (Fig. 59). Caliper opening and ledges should be to rear as shown.

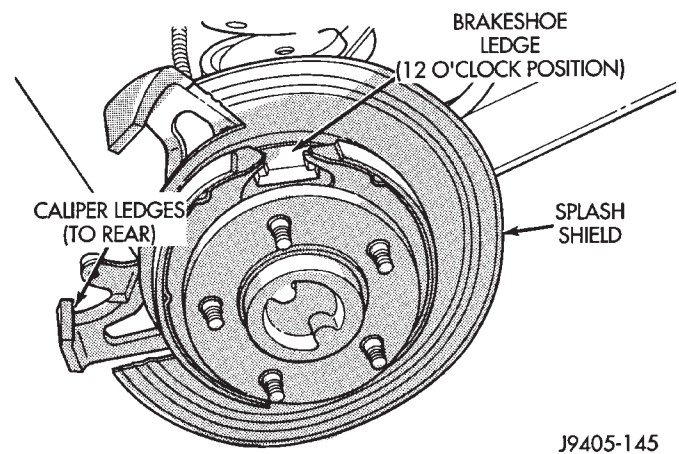


Fig. 59 Checking Caliper Bracket And Shield Position

(9) Install axle shaft, refer to Group 3 Differential and Driveline.

(10) Install rotor, caliper, and wheel and tire assembly, then adjust parking brake shoes.

(11) Lower vehicle and verify correct service and parking brake operation.

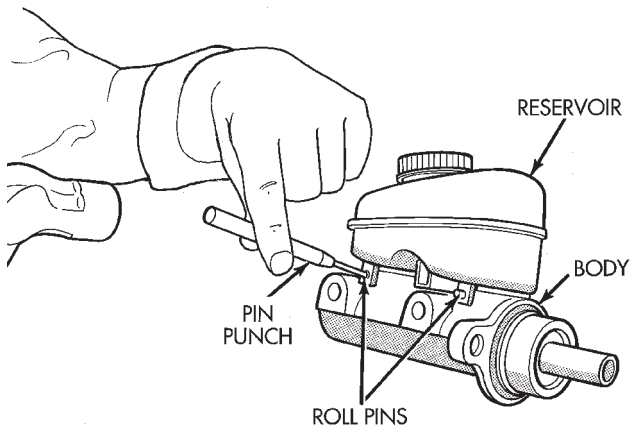
DISASSEMBLY AND ASSEMBLY

MASTER CYLINDER RESERVOIR

REMOVAL

(1) Remove reservoir cap and empty fluid into drain container.

(2) Remove pins that retain reservoir to master cylinder. Use hammer and pin punch to remove pins (Fig. 60).

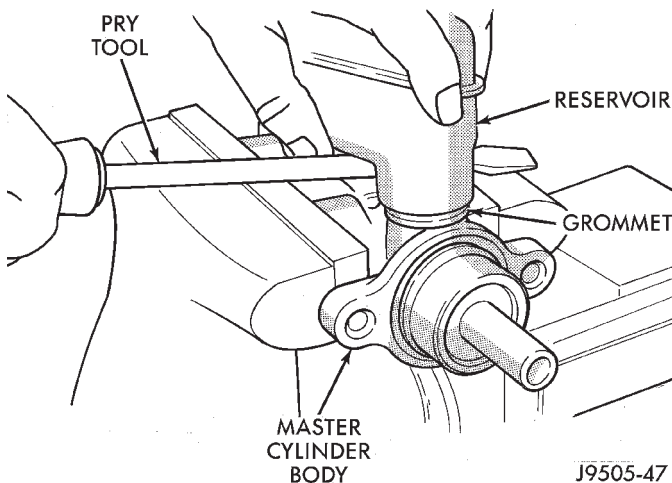


J9505-77

Fig. 60 Reservoir Retaining Pins

(3) Clamp cylinder body in vise with brass protective jaws.

(4) Loosen reservoir from grommets with pry tool (Fig. 61).

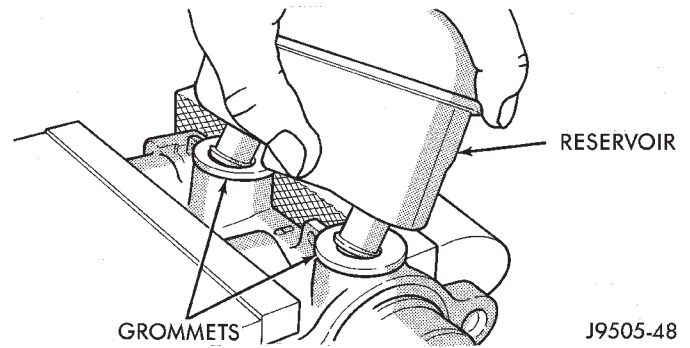


J9505-47

Fig. 61 Loosening Reservoir

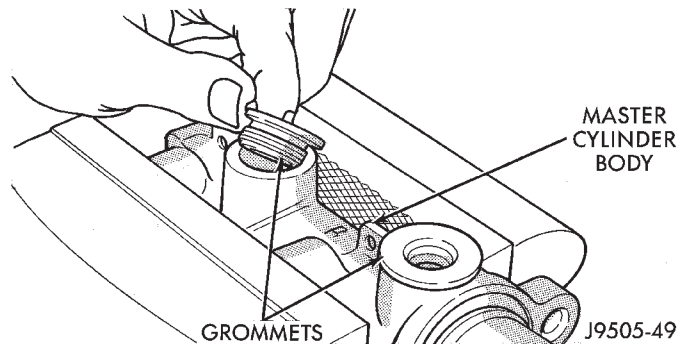
(5) Remove reservoir by rocking it to one side and pulling free of grommets (Fig. 62).

(6) Remove old grommets from cylinder body (Fig. 63).



J9505-48

Fig. 62 Reservoir Removal



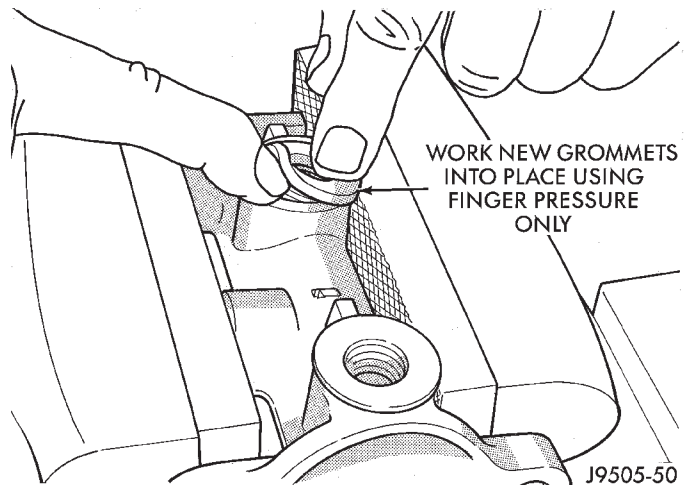
J9505-49

Fig. 63 Grommet Removal

INSTALLATION

CAUTION: Do not use any type of tool to install the grommets. Tools may cut, or tear the grommets creating a leak problem after installation. Install the grommets using finger pressure only.

(1) Lubricate new grommets with clean brake fluid and install new grommets in cylinder body (Fig. 64). Use finger pressure to install and seat grommets.



J9505-50

Fig. 64 Grommet Installation

DISASSEMBLY AND ASSEMBLY (Continued)

(2) Start reservoir in grommets. Then rock reservoir back and forth while pressing downward to seat it in grommets.

(3) Install pins that retain reservoir to cylinder body.

(4) Fill and bleed master cylinder on bench before installation in vehicle.

DISC BRAKE CALIPER**DISASSEMBLY**

(1) Remove brake shoes from caliper.

(2) Drain brake fluid out of caliper.

(3) Take a piece of wood and pad it with one-inch thickness of shop towels. Place this piece in the out-board shoe side of the caliper in front of the piston. This will cushion and protect caliper piston during removal (Fig. 65).

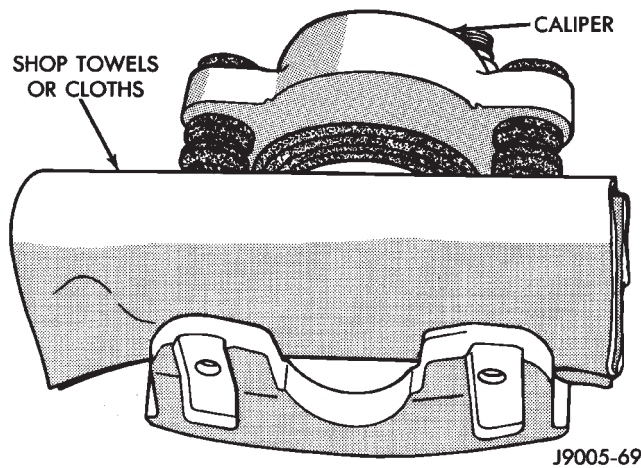


Fig. 65 Padding Caliper Interior

(4) Remove caliper piston with **short bursts** of low pressure compressed air. Direct air through fluid inlet port and ease piston out of bore (Fig. 66).

CAUTION: Do not blow the piston out of the bore with sustained air pressure. This could result in a cracked piston. Use only enough air pressure to ease the piston out.

WARNING: NEVER ATTEMPT TO CATCH THE PISTON AS IT LEAVES THE BORE. THIS MAY RESULT IN PERSONAL INJURY.

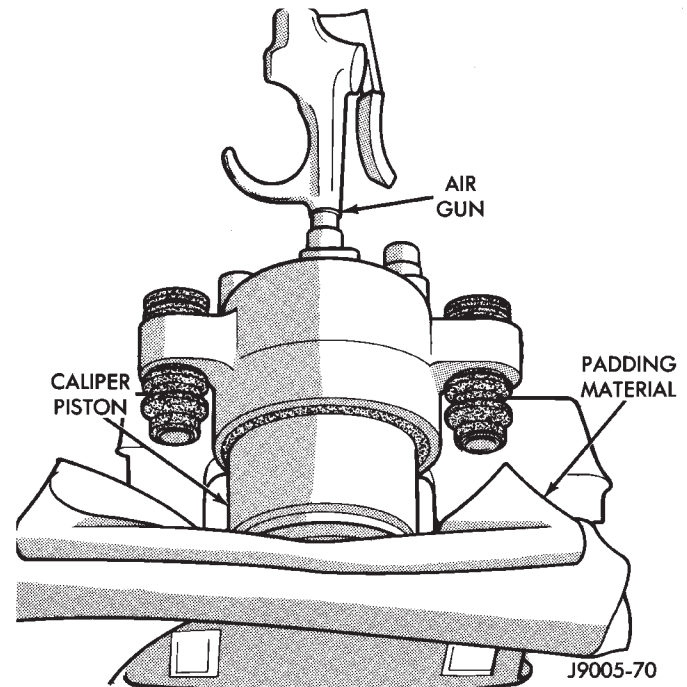


Fig. 66 Caliper Piston Removal

(5) Remove caliper piston dust boot with suitable pry tool (Fig. 67).

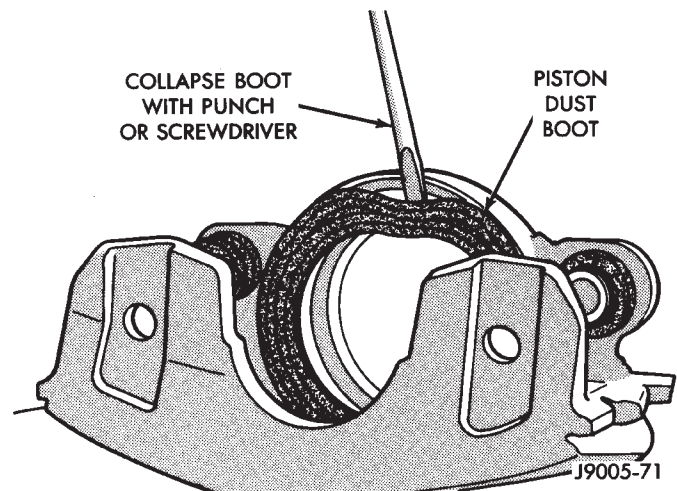


Fig. 67 Caliper Piston Dust Boot Removal

DISASSEMBLY AND ASSEMBLY (Continued)

(6) Remove caliper piston seal with wood or plastic tool (Fig. 68). Do not use metal tools as they will scratch piston bore.

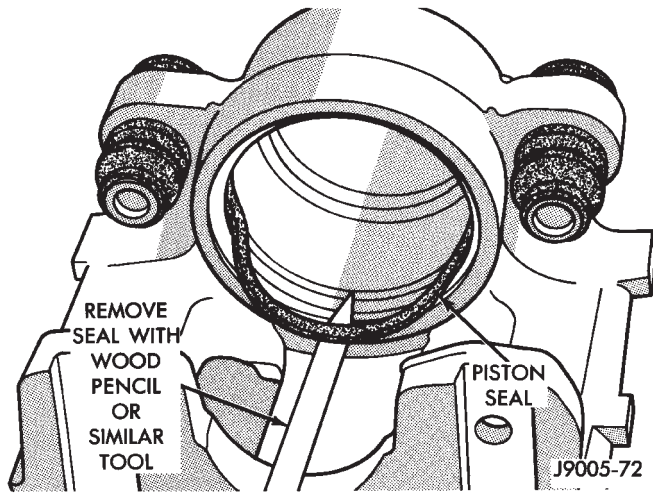


Fig. 68 Piston Seal Removal

(7) Remove caliper mounting bolt bushings and boots (Fig. 69).

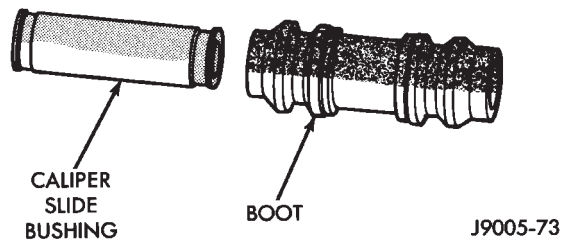


Fig. 69 Mounting Bolt Bushing And Boot

ASSEMBLY

CAUTION: Dirt, oil, and solvents can damage caliper seals. Insure assembly area is clean and dry.

- (1) Lubricate caliper piston bore, new piston seal and piston with clean brake fluid.
- (2) Lubricate caliper bushings and interior of bushing boots with silicone grease.
- (3) Install bushing boots in caliper, then insert bushing into boot and push bushing into place (Fig. 70).
- (4) Install new piston seal into seal groove with finger (Fig. 71).
- (5) Install new dust boot on caliper piston and seat boot in piston groove (Fig. 72).

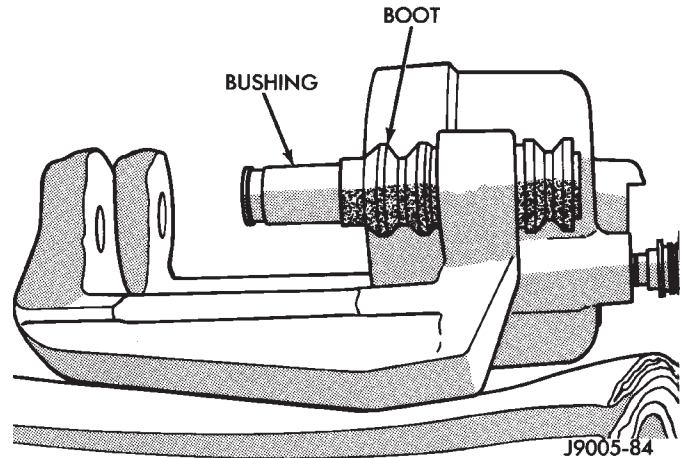


Fig. 70 Bushings And Boots Installation

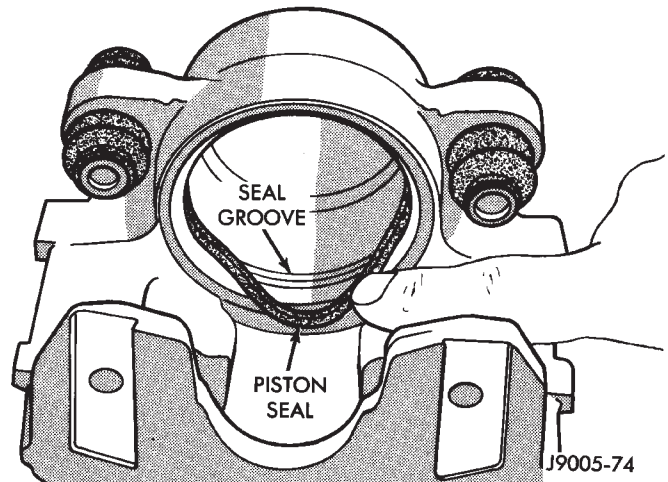


Fig. 71 Piston Seal Installation

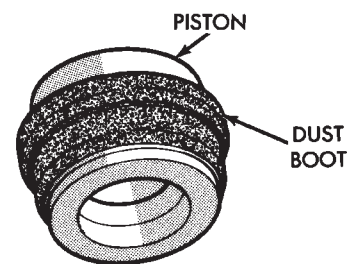


Fig. 72 Dust Boot On Piston

DISASSEMBLY AND ASSEMBLY (Continued)

(6) Press piston into caliper bore by hand, use a turn and push motion to work piston into seal (Fig. 73).

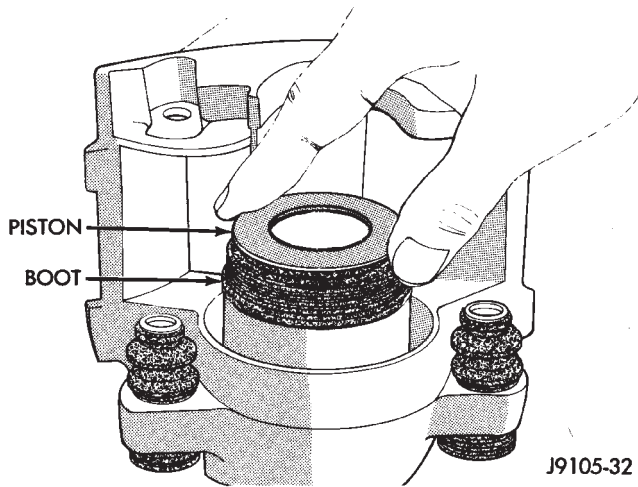


Fig. 73 Caliper Piston Installation

- (7) Press caliper piston to bottom of bore.
 (8) Seat dust boot in caliper with Installer Tool C-4842 and Tool Handle C-4171 (Fig. 74).
 (9) Replace caliper bleed screw if removed.

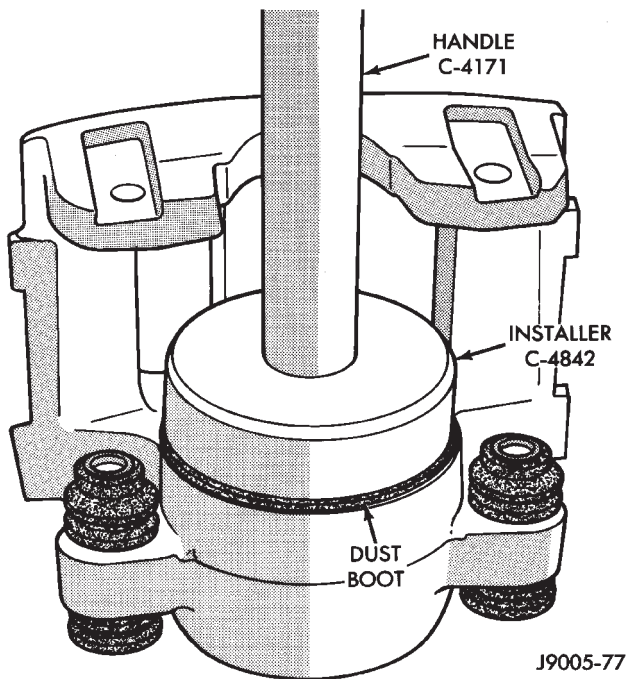


Fig. 74 Piston Dust Boot Installation

REAR DISC BRAKE CALIPER**DISASSEMBLY**

- (1) Remove caliper and brake shoes.
 (2) Remove mounting bolt boots and bushings from caliper (Fig. 75).

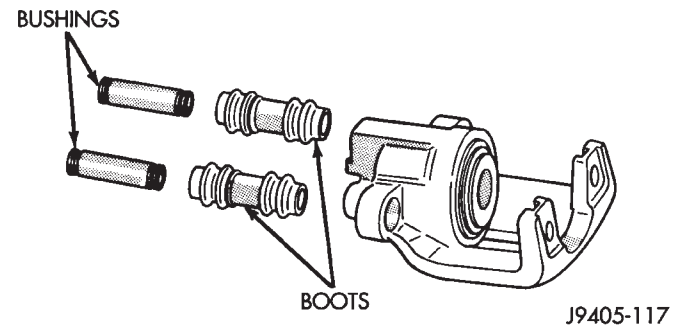


Fig. 75 Mounting Bolt Bushings And Boots

- (3) Take a piece of wood and pad it with one-inch thickness of shop towels. Place this piece in the out-board shoe side of the caliper in front of the piston. This will cushion and protect caliper piston during removal (Fig. 76).

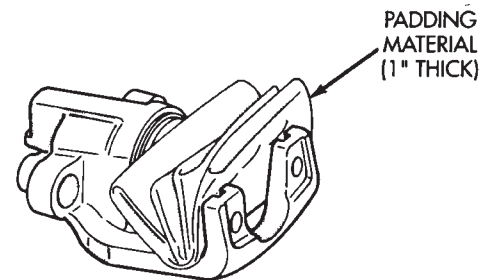


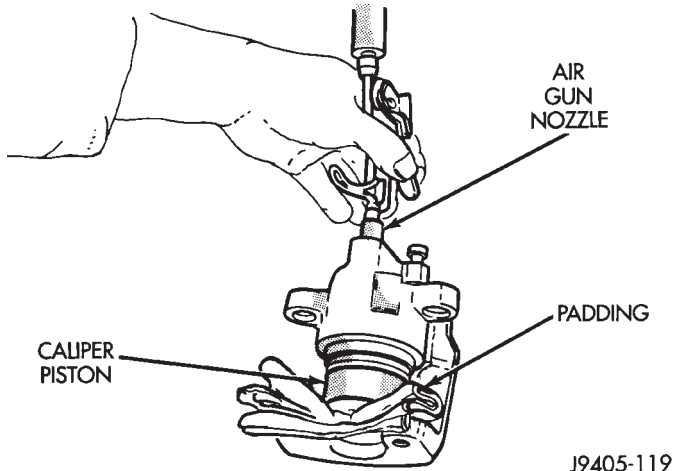
Fig. 76 Padding Caliper

- (4) Remove caliper piston with **short bursts** of low pressure compressed air. Direct air through fluid inlet port and ease piston out of bore (Fig. 77).

CAUTION: Do not blow the piston out of the bore with sustained air pressure. This could result in a cracked piston. Use only enough air pressure to ease the piston out.

WARNING: NEVER ATTEMPT TO CATCH THE PISTON AS IT LEAVES THE BORE. THIS MAY RESULT IN PERSONAL INJURY.

DISASSEMBLY AND ASSEMBLY (Continued)



J9405-119

Fig. 77 Caliper Piston Removal

- (5) Remove caliper piston dust boot (Fig. 78).
- (6) Remove and discard caliper piston seal with pencil, or plastic tool (Fig. 79). Do not use metal tools as they will scratch piston bore.

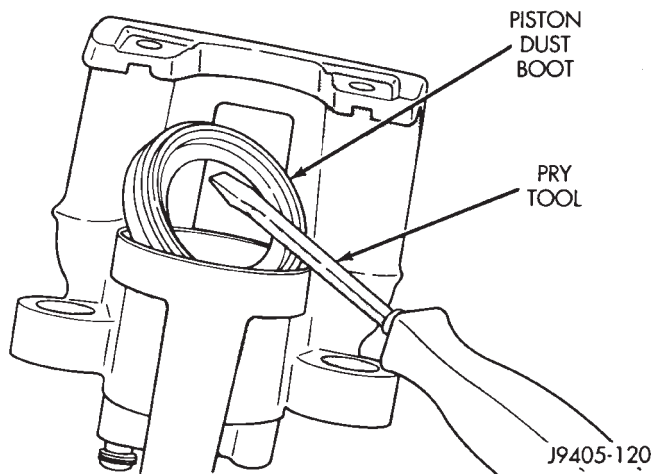


Fig. 78 Caliper Piston Dust Boot

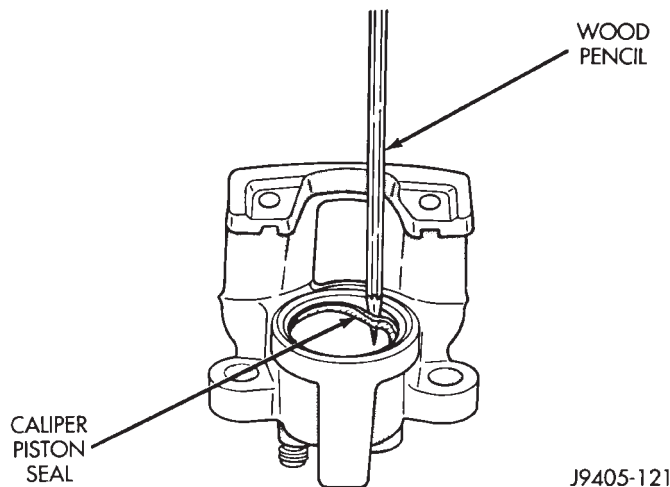
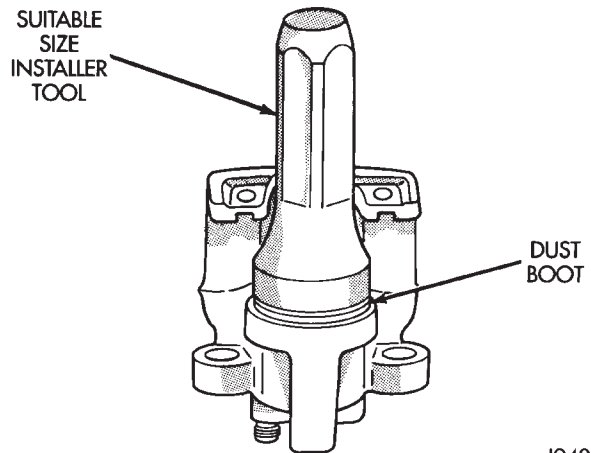


Fig. 79 Caliper Piston Seal

ASSEMBLY

CAUTION: Dirt, oil, and solvents can damage caliper seals. Insure assembly area is clean and dry.

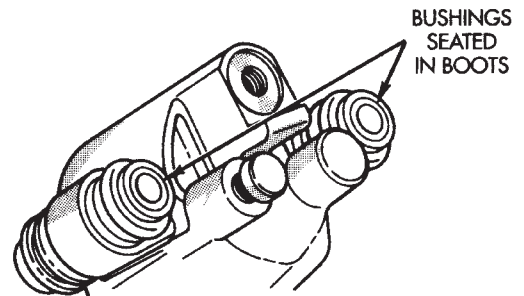
- (1) Lubricate caliper piston bore, new piston seal and piston with clean brake fluid.
- (2) Lubricate caliper bushings and interior of bushing boots with silicone grease.
- (3) Install new piston seal into seal groove. Press seal into place with fingertips.
- (4) Install new dust boot on caliper piston and seat boot in piston groove.
- (5) Press piston into caliper bore by hand, use a turn and push motion to work piston into the caliper bore.
- (6) Press caliper piston to bottom of bore.
- (7) Seat dust boot in caliper either by hand, or with a suitable size installer tool (Fig. 80).



J9405-125

Fig. 80 Seating Caliper Piston Dust Boot

- (8) Install caliper bleed screw, if removed.
- (9) Install bushing boot seals and center boot seals in the caliper.
- (10) Install bushings into the caliper. Be sure boot seal lips are seated in grooves at the ends of bushings (Fig. 81).
- (11) Install brake shoes in caliper and install caliper.



J9405-127

Fig. 81 Bushings Installed In Boots

CLEANING AND INSPECTION

CALIPER

CLEANING

Clean the caliper components with clean brake fluid or brake clean only. Wipe the caliper and piston dry with lint free towels or use low pressure compressed air.

CAUTION: Do not use gasoline, kerosene, thinner, or similar solvents. These products may leave a residue that could damage the piston and seal.

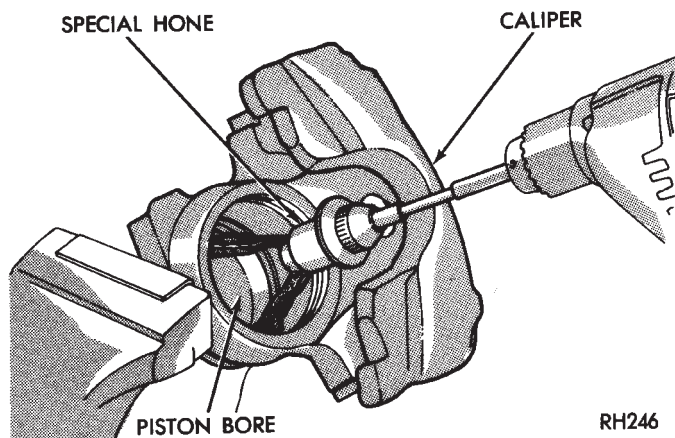
INSPECTION

The piston is made from a phenolic resin (plastic material) and should be smooth and clean.

The piston must be replaced if cracked or scored. Do not attempt to restore a scored piston surface by sanding or polishing.

CAUTION: If the caliper piston is replaced, install the same type of piston in the caliper. Never interchange phenolic resin and steel caliper pistons. The pistons, seals, seal grooves, caliper bore and piston tolerances are different.

The bore can be **lightly** polished with a brake hone to remove very minor surface imperfections (Fig. 82). The caliper should be replaced if the bore is severely corroded, rusted, scored, or if polishing would increase bore diameter more than 0.025 mm (0.001 inch).



RH246

Fig. 82 Polishing Piston Bore

ADJUSTMENTS

STOP LAMP SWITCH

- (1) Press and hold brake pedal in applied position.
- (2) Pull switch plunger all the way out to fully extended position.
- (3) Release brake pedal. Then pull pedal fully rearward. Pedal will set plunger to correct position as pedal pushes plunger into switch body. Switch will make ratcheting sound as it self adjusts.

PARKING BRAKE CABLE TENSIONER

NOTE: Parking brake adjustment is only necessary when the tensioner, or a cable has been replaced or disconnected.

ADJUSTMENT

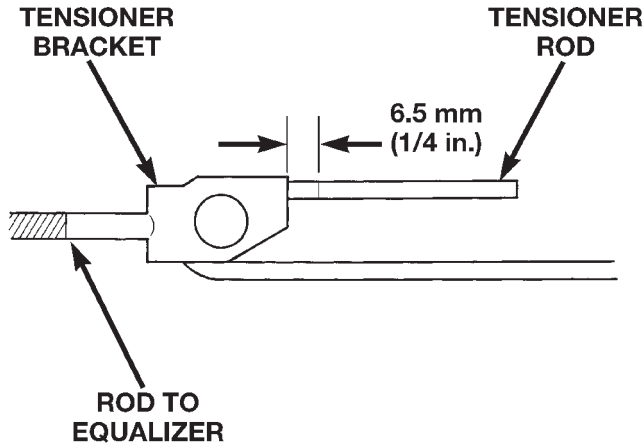
- (1) Raise vehicle.
- (2) Back off tensioner adjusting nut to create slack in cables.
- (3) Remove rear wheel/tire assemblies and remove brake drums.
- (4) Check rear brake shoe adjustment with standard brake gauge.

CAUTION: Excessive shoe-to-drum clearance, or worn brake components will result in faulty parking brake adjustment and operation.

- (5) Verify that parking brake cables operate freely and are not binding, or seized. Replace faulty cables, before proceeding.
- (6) Reinstall brake drums and wheel/tire assemblies after brake shoe adjustment is complete.
- (7) Lower vehicle enough for access to parking brake lever. Then **fully** apply parking brakes. Leave brakes applied until adjustment is complete.
- (8) Raise vehicle and mark tensioner rod 6.5 mm (1/4 in.) from tensioner bracket (Fig. 83).
- (9) Tighten adjusting nut at equalizer until mark on tensioner rod moves into alignment with tensioner bracket.
- (10) Lower vehicle until rear wheels are 15-20 cm (6-8 in.) off shop floor.
- (11) Release parking brake lever and verify that rear wheels rotate freely without drag.
- (12) Lower vehicle.

NOTE: Do not loosen/tighten equalizer adjusting nut for any reason after completing adjustment.

ADJUSTMENTS (Continued)



80add400

Fig. 83 Tensioner Rod Measurement

PARKING BRAKE SHOE

- (1) Remove wheel and tire assemblies.
- (2) Secure rotor with two wheel nuts.
- (3) Remove rubber access plug from back of splash shield.
- (4) Insert brake tool through access hole in splash shield (Fig. 84). Position tool at bottom of star wheel.
- (5) Rotate star wheel upward in counterclockwise direction to expand shoes (while facing front of vehicle).
- (6) Expand shoes until light drag is experienced. Then back off adjuster screw only enough to eliminate drag.
- (7) Install plug in splash shield access hole.
- (8) Install wheel and tire assemblies.

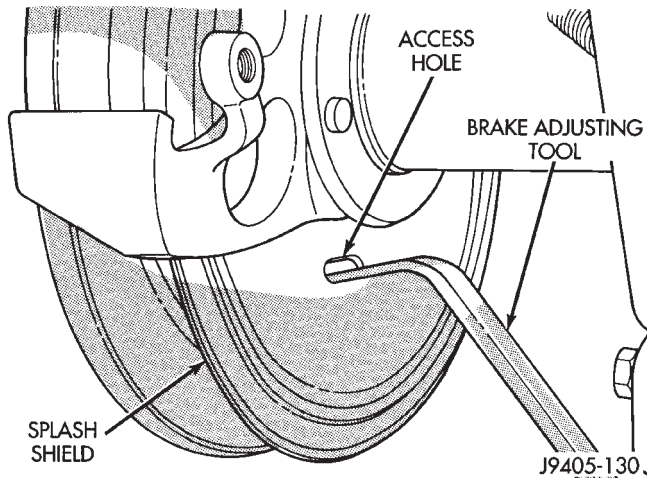


Fig. 84 Park Brake Shoe Adjustment

SPECIFICATIONS

BRAKE FLUID

The brake fluid used in this vehicle must conform to DOT 3 specifications and SAE J1703 standards. No other type of brake fluid is recommended or approved for usage in the vehicle brake system. Use only Mopar brake fluid or an equivalent from a tightly sealed container.

CAUTION: Never use reclaimed brake fluid or fluid from an container which has been left open. An open container will absorb moisture from the air and contaminate the fluid.

CAUTION: Never use any type of a petroleum-based fluid in the brake hydraulic system. Use of such type fluids will result in seal damage of the vehicle brake hydraulic system causing a failure of the vehicle brake system. Petroleum based fluids would be items such as engine oil, transmission fluid, power steering fluid ect.

BRAKE COMPONENTS

Front Disc Brake Caliper

Type Floating

Front Disc Brake Rotor

Type Ventilated

Max. Runout 0.13 mm (0.005 in.)

Max. Thickness Variation . . . 0.013 mm (0.0005 in.)

Min. Thickness 22.7 mm (0.8937 in.)

Rear Disc Brake Caliper

Type Floating

Rear Disc Brake Rotor

Type Solid

Max. Runout 0.13 mm (0.005 in.)

Max. Thickness Variation . . . 0.0254 mm (0.001 in.)

Min. Thickness 10.65 mm (0.4193 in.)

Brake Booster

Type Dual Diaphragm

TORQUE CHART

DESCRIPTION

TORQUE

Brake Pedal

Support Bolt 23-34 N·m (17-25 ft. lbs.)

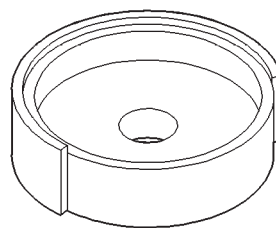
Pivot Bolt/Nut 27-35 N·m (20-26 ft. lbs.)

SPECIFICATIONS (Continued)

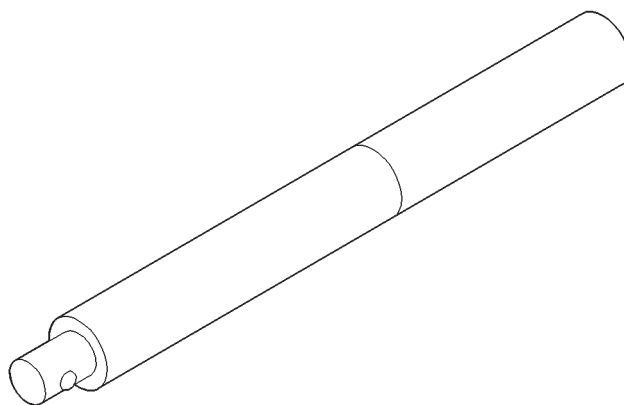
DESCRIPTION	TORQUE
Brake Booster	
Mounting Nuts	39 N·m (29 ft. lbs.)
Master Cylinder	
Mounting Nuts	18 N·m (155 in. lbs.)
Primary Brake Line	16 N·m (144 in. lbs.)
Secondary Brake Line.	16 N·m (144 in. lbs.)
Combination Valve	
Mounting Nuts	18 N·m (155 in. lbs.)
Primary/Secondary Brake Lines21 N·m (185 in. lbs.)
Front Caliper	
Mounting Bolts	10-20 N·m (7-15 ft. lbs.)
Brake Hose Bolt	31 N·m (23 ft. lbs.)
Rear Caliper	
Mounting Bolts	10-20 N·m (7-15 ft. lbs.)
Brake Hose Bolt	31 N·m (23 ft. lbs.)
Parking Brake	
Lever Screws	10-14 N·m (7-10 ft. lbs.)
Lever Bracket Screws	10-14 N·m (7-10 ft. lbs.)
Cable Retainer Nut.	1-2 N·m (12-16 in. lbs.)

SPECIAL TOOLS

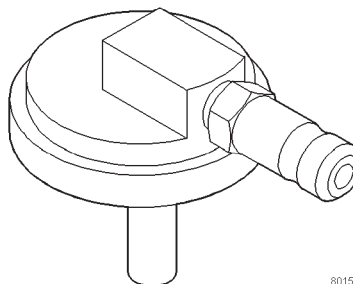
BASE BRAKES



Installer Caliper Dust Boot C-4842



Handle C-4171



8015c88d

Adapter Pressure Bleeder 6921

ANTILOCK BRAKES

INDEX

	page		page
GENERAL INFORMATION		REMOVAL AND INSTALLATION	
ANTILOCK BRAKE SYSTEM	35	ACCELERATION SWITCH	41
DESCRIPTION AND OPERATION		FRONT WHEEL SPEED SENSOR	40
ABS WARNING LAMP	38	HYDRAULIC CONTROL UNIT/CONTROLLER	
ACCELERATION SWITCH	38	ANTILOCK BRAKES	39
ANTILOCK BRAKE SYSTEM	36	REAR WHEEL SPEED SENSOR	40
COMBINATION VALVE	38	DISASSEMBLY AND ASSEMBLY	
CONTROLLER ANTILOCK BRAKES	36	HYDRAULIC CONTROL UNIT/CONTROLLER	
HYDRAULIC CONTROL UNIT	36	ANTILOCK BRAKE	42
WHEEL SPEED SENSORS AND TONE WHEEL .	37	SPECIFICATIONS	
DIAGNOSIS AND TESTING		TORQUE CHART	42
ANTILOCK BRAKES	38		
SERVICE PROCEDURES			
BLEEDING ABS BRAKE SYSTEM	39		

GENERAL INFORMATION

ANTILOCK BRAKE SYSTEM

The antilock brake system (ABS) is an electronically operated, all wheel brake control system.

The system is designed to prevent wheel lockup and maintain steering control during periods of high wheel slip when braking. Preventing lockup is accomplished by modulating fluid pressure to the wheel brake units.

The hydraulic system is a three channel design. The front wheel brakes are controlled individually and the rear wheel brakes in tandem (Fig. 1). The ABS electrical system is separate from other electrical circuits in the vehicle. A specially programmed controller antilock brake unit operates the system components.

ABS system major components include:

- Controller Antilock Brakes (CAB)
- Hydraulic Control Unit (HCU)
- Wheel Speed Sensors (WSS)
- Acceleration Switch
- ABS Warning Light

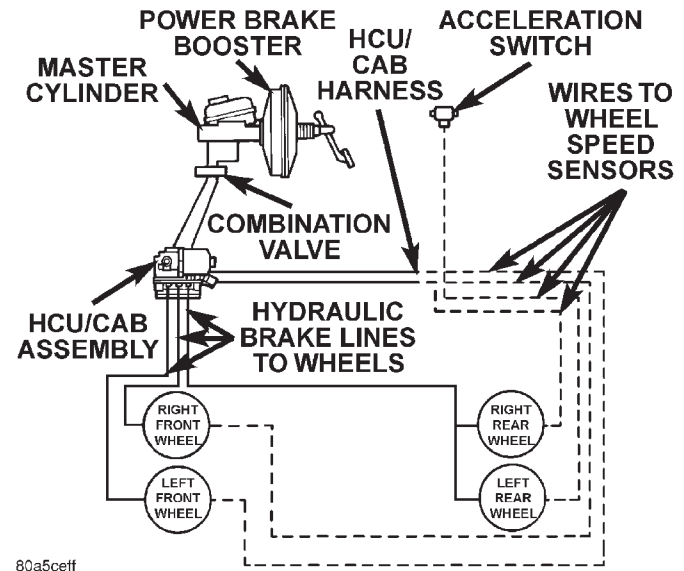


Fig. 1 Antilock Brake System

DESCRIPTION AND OPERATION

ANTILOCK BRAKE SYSTEM

The purpose of the antilock system is to prevent wheel lockup during periods of high wheel slip. Preventing lockup helps maintain vehicle braking action and steering control.

The antilock CAB activates the system whenever sensor signals indicate periods of high wheel slip. High wheel slip can be described as the point where wheel rotation begins approaching 20 to 30 percent of actual vehicle speed during braking. Periods of high wheel slip occur when brake stops involve high pedal pressure and rate of vehicle deceleration.

Battery voltage is supplied to the CAB ignition terminal when the ignition switch is turned to Run position. The CAB performs a system initialization procedure at this point. Initialization consists of a static and dynamic self check of system electrical components.

The static check occurs after the ignition switch is turned to Run position. The dynamic check occurs when vehicle road speed reaches approximately 30 kph (18 mph). During the dynamic check, the CAB briefly cycles the pump and solenoids to verify operation.

If an ABS component exhibits a fault during initialization, the CAB illuminates the amber warning light and registers a fault code in the microprocessor memory.

NORMAL BRAKING

During normal braking, the master cylinder, power booster and wheel brake units all function as they would in a vehicle without ABS. The HCU components are not activated.

ANTILOCK BRAKING

The antilock system prevents lockup during high slip conditions by modulating fluid apply pressure to the wheel brake units.

Brake fluid apply pressure is modulated according to wheel speed, degree of slip and rate of deceleration. A sensor at each wheel converts wheel speed into electrical signals. These signals are transmitted to the CAB for processing and determination of wheel slip and deceleration rate.

The ABS system has three fluid pressure control channels. The front brakes are controlled separately and the rear brakes in tandem. A speed sensor input signal indicating a high slip condition activates the CAB antilock program.

Two solenoid valves are used in each antilock control channel. The valves are all located within the HCU valve body and work in pairs to either increase, hold, or decrease apply pressure as needed in the individual control channels.

The solenoid valves are not static during antilock braking. They are cycled continuously to modulate pressure. Solenoid cycle time in antilock mode can be measured in milliseconds.

CONTROLLER ANTILOCK BRAKES

The CAB monitors wheel speed sensor inputs continuously while the vehicle is in motion. However, the CAB will not activate any ABS components as long as sensor inputs and the acceleration switch indicate normal braking.

The CAB is mounted to the HCU and operates the ABS system (Fig. 2) separate from other vehicle electrical circuits. CAB voltage source is through the ignition switch in the RUN position.

The CAB contains dual microprocessors. A logic block in each microprocessor receives identical sensor signals. These signals are processed and compared simultaneously.

The CAB contains a self check program that illuminates the ABS warning light when a system fault is detected. Faults are stored in a diagnostic program memory and are accessible with the DRB scan tool.

ABS faults remain in memory until cleared, or until after the vehicle is started approximately 50 times. Stored faults are **not** erased if the battery is disconnected.

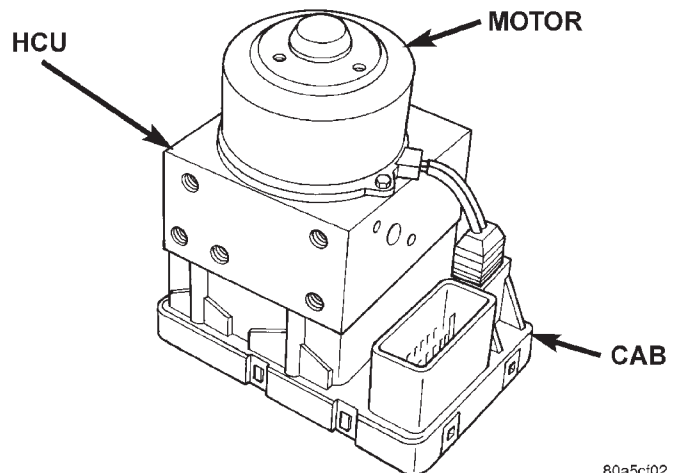


Fig. 2 Controller Antilock Brakes

HYDRAULIC CONTROL UNIT

The HCU consists of a valve body, pump body, accumulators, pump motor, and wire harnesses (Fig. 2).

The pump, motor, and accumulators are combined into an assembly attached to the valve body. The accumulators store the extra fluid released to the system for ABS mode operation. The pump provides the fluid volume needed and is operated by a DC type motor. The motor is controlled by the CAB.

DESCRIPTION AND OPERATION (Continued)

The valve body contains the solenoid valves. The valves modulate brake pressure during antilock braking and are controlled by the CAB.

The HCU provides three channel pressure control to the front and rear brakes. One channel controls the rear wheel brakes in tandem. The two remaining channels control the front wheel brakes individually.

During antilock braking, the solenoid valves are opened and closed as needed. The valves are not static. They are cycled rapidly and continuously to modulate pressure and control wheel slip and deceleration.

During normal braking, the HCU solenoid valves and pump are not activated. The master cylinder and power booster operate the same as a vehicle without an ABS brake system.

During antilock braking, solenoid valve pressure modulation occurs in three stages, pressure increase, pressure hold, and pressure decrease. The valves are all contained in the valve body portion of the HCU.

Pressure Decrease

The outlet valve is opened and the inlet valve is closed during the pressure decrease cycle.

A pressure decrease cycle is initiated when speed sensor signals indicate high wheel slip at one or more wheels. At this point, the CAB closes the inlet then opens the outlet valve, which also opens the return circuit to the accumulators. Fluid pressure is allowed to bleed off (decrease) as needed to prevent wheel lock.

Once the period of high wheel slip has ended, the CAB closes the outlet valve and begins a pressure increase or hold cycle as needed.

Pressure Hold

Both solenoid valves are closed in the pressure hold cycle. Fluid apply pressure in the control channel is maintained at a constant rate. The CAB maintains the hold cycle until sensor inputs indicate a pressure change is necessary.

Pressure Increase

The inlet valve is open and the outlet valve is closed during the pressure increase cycle. The pressure increase cycle is used to counteract unequal wheel speeds. This cycle controls re-application of fluid apply pressure due to changing road surfaces or wheel speed.

WHEEL SPEED SENSORS AND TONE WHEEL

A speed sensor is used at each wheel. The front sensors are mounted to the steering knuckles. The rear sensors are at the outboard end of the axle.

The sensors convert wheel speed into a small AC electrical signal. This signal is transmitted to the CAB. The CAB converts the AC signal into a digital signal for each wheel. This voltage is generated by magnetic induction when a tone wheel passes by the stationary magnetic of the wheel speed sensor.

A gear type tone ring serves as the trigger mechanism for each sensor. The tone rings are mounted at the outboard ends of the front and rear axle shafts.

Different sensors are used at the front and rear wheels (Fig. 3). The front/rear sensors have the same electrical values but are not interchangeable. The sensors have a resistance between 900 and 1300 ohms.

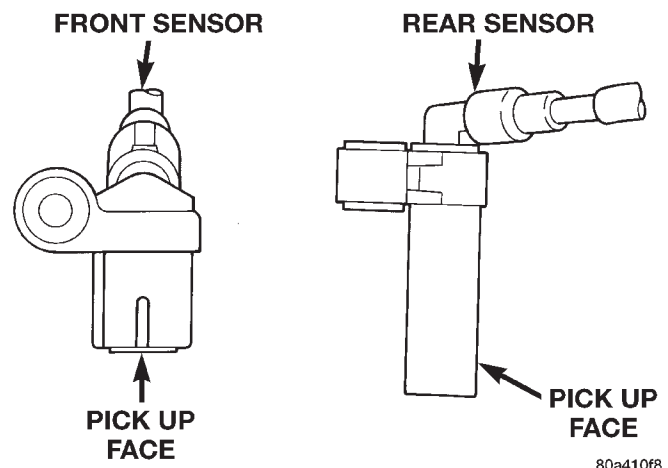


Fig. 3 Wheel Speed Sensors

SPEED SENSOR AIR GAP

FRONT SENSOR

Front sensor air gap is fixed and not adjustable. Only rear sensor air gap is adjustable.

Although front air gap is not adjustable, it can be checked if diagnosis indicates this is necessary. Front air gap should be 0.36 to 1.5 mm (0.014 to 0.059 in.). If gap is incorrect, the sensor is either loose, or damaged.

DESCRIPTION AND OPERATION (Continued)**REAR SENSOR**

A rear sensor air gap adjustment is only needed when reinstalling an original sensor. Replacement sensors have an air gap spacer attached to the sensor pickup face. The spacer establishes correct air gap when pressed against the tone ring during installation. As the tone ring rotates, it peels the spacer off the sensor to create the required air gap. Rear sensor air gap is 0.92 to 1.275 mm (0.036 to 0.05 in.).

COMBINATION VALVE

The combination valve contains a pressure differential valve and switch and a rear brake proportioning valve. The valve is not repairable and must be replaced as an assembly if diagnosis indicates this is necessary.

The pressure differential switch is connected to the brake warning light. The switch is actuated by movement of the switch valve. The switch monitors fluid pressure in the separate front/rear brake hydraulic circuits.

A decrease or loss of fluid pressure in either hydraulic circuit will cause the switch valve to shuttle to the low pressure side. Movement of the valve pushes the switch plunger upward. This action closes the switch internal contacts completing the electrical circuit to the red warning light. The switch valve will remain in an actuated position until repairs to the brake system are made.

The proportioning valve is used to balance front-rear brake action. The valve allows normal fluid flow during moderate effort brake stops. The valve only controls (meters) fluid flow during high effort brake stops.

ACCELERATION SWITCH

The acceleration switch is located under the rear seat. The switch (Fig. 4), provides an additional vehicle deceleration reference during 4WD operation. The switch is monitored by the CAB at all times. The switch reference signal is utilized by the CAB when all wheels are decelerating at the same speed.

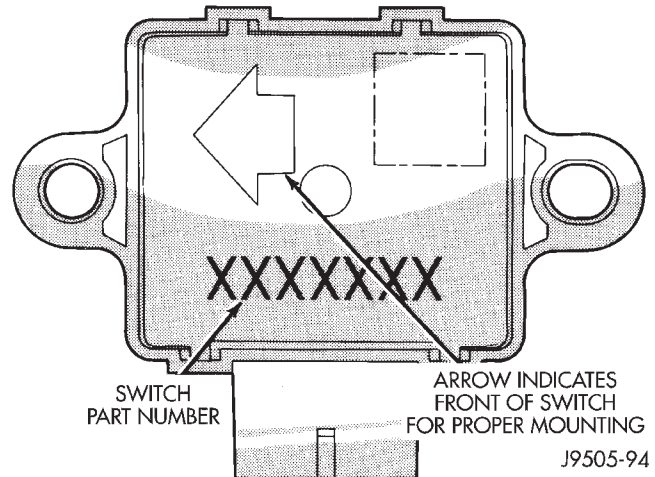


Fig. 4 Acceleration Switch

ABS WARNING LAMP

The amber ABS warning lamp is located in the instrument cluster. The lamp illuminates at start-up to perform a self check. The lamp goes out when the self check program determines the system is operating normal. If an ABS component exhibits a fault the CAB will illuminate the lamp and register a trouble code in the microprocessor. The lamp is controlled by the CAB. The CAB controls the lamp by directly grounding the circuit.

DIAGNOSIS AND TESTING**ANTILOCK BRAKES**

The ABS brake system performs several self-tests every time the ignition switch is turned on and the vehicle is driven. The CAB monitors the systems input and output circuits to verify the system is operating correctly. If the on board diagnostic system senses that a circuit is malfunctioning the system will set a trouble code in its memory.

NOTE: The MDS or DRB III scan tool is used to diagnose the ABS system. For additional information refer to the Antilock Brake section in Group 8W. For test procedures refer to the Chassis Diagnostic Manual.

SERVICE PROCEDURES

BLEEDING ABS BRAKE SYSTEM

ABS system bleeding requires conventional bleeding methods plus use of the DRB scan tool. The procedure involves performing a base brake bleeding, followed by use of the scan tool to cycle and bleed the HCU pump and solenoids. A second base brake bleeding procedure is then required to remove any air remaining in the system.

- (1) Perform base brake bleeding. Refer to base brake section for procedure.
- (2) Connect scan tool to the Data Link Connector.
- (3) Select ANTILOCK BRAKES, followed by MISCELLANEOUS, then ABS BRAKES. Follow the instructions displayed. When scan tool displays TEST COMPLETE, disconnect scan tool and proceed.
- (4) Perform base brake bleeding a second time. Refer to base brake section for procedure.
- (5) Top off master cylinder fluid level and verify proper brake operation before moving vehicle.

REMOVAL AND INSTALLATION

HYDRAULIC CONTROL UNIT/CONTROLLER ANTILOCK BRAKES

REMOVAL

- (1) Remove negative battery cable from the battery.
- (2) Remove air cleaner housing.
- (3) Remove windshield reservoir mounting bolts and move the reservoir to the side.
- (4) Remove steering gear shield.
- (5) Pull CAB harness connector release out and remove connector (Fig. 5).
- (6) Remove the brake lines from the HCU.
- (7) Remove HCU/CAB bracket mounting nuts (Fig. 6).
- (8) Remove HCU/CAB assembly from the vehicle.
- (9) Remove bracket bolts from the HCU/CAB assembly.

INSTALLATION

- (1) Install bracket onto the HCU/CAB assembly.

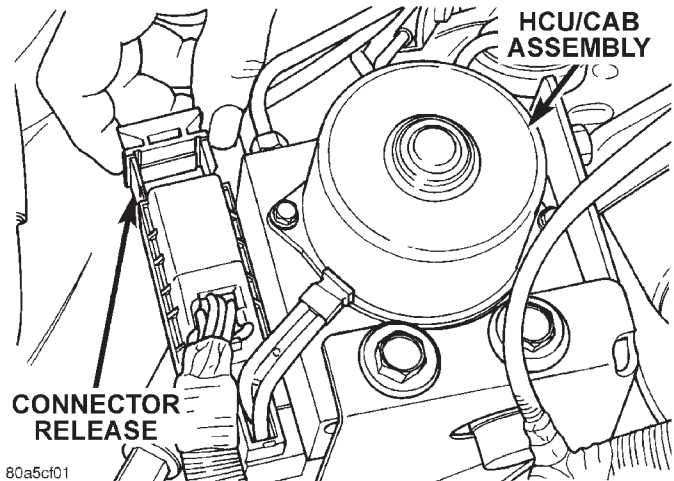


Fig. 5 CAB Connector Release

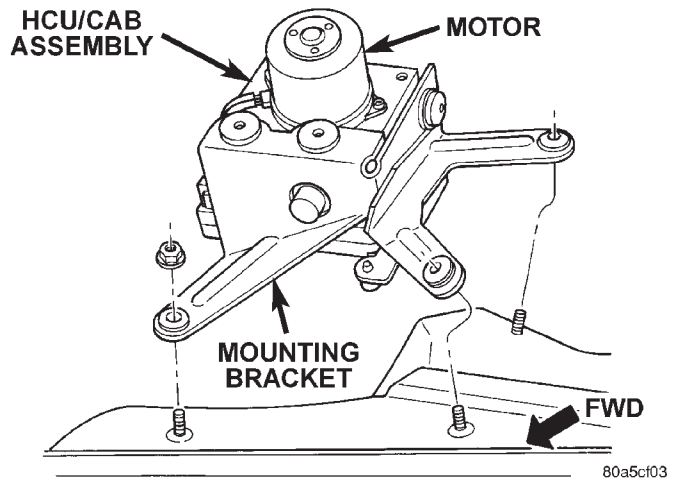
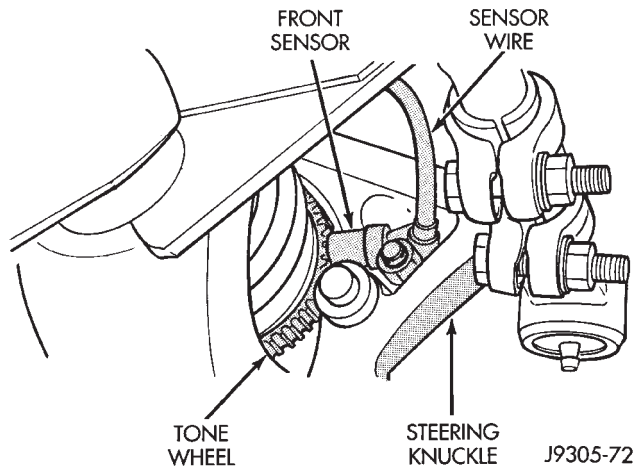


Fig. 6 HCU/CAB Assembly

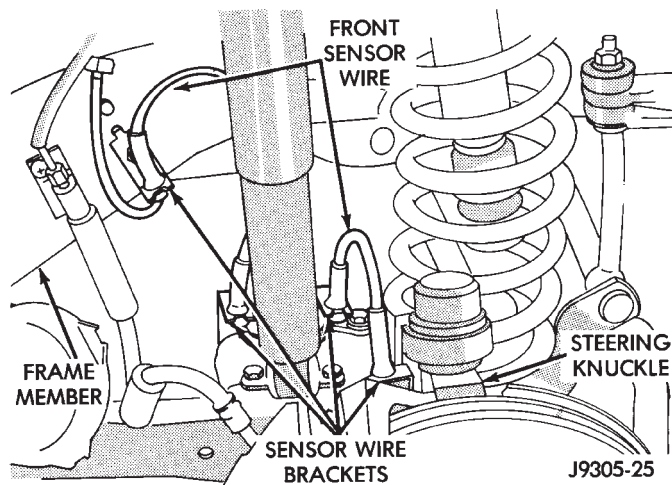
- (2) Install HCU/CAB assembly in the vehicle and tighten mounting nuts to 12 N·m (9 ft. lbs.).
- (3) Install the brake lines to the HCU and tighten to 16 N·m (12 ft. lbs.).
- (4) Install CAB harness connector and push-in connector release.
- (5) Install steering gear shield.
- (6) Install windshield reservoir and mounting bolts.
- (7) Install air cleaner housing.
- (8) Install negative battery cable to the battery.
- (9) Bleed complete brake system.

REMOVAL AND INSTALLATION (Continued)**FRONT WHEEL SPEED SENSOR****REMOVAL**

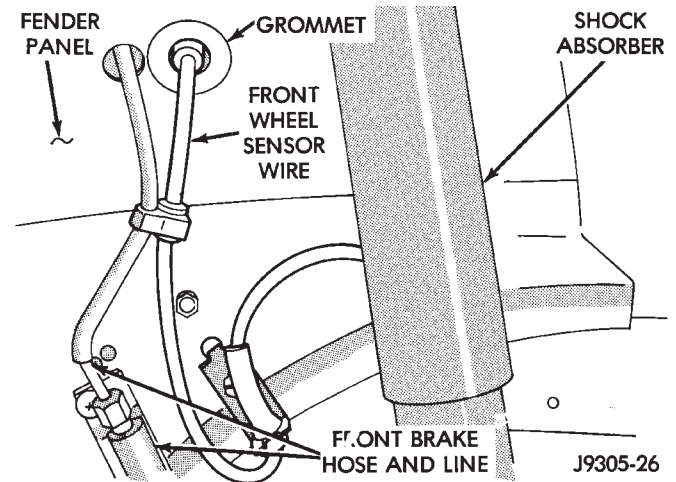
- (1) Turn ignition switch to OFF position.
- (2) Raise vehicle.
- (3) Remove wheel and tire assembly.
- (4) Remove bolt attaching front sensor to steering knuckle (Fig. 7).

**Fig. 7 Sensor Location**

- (5) Disengage sensor wire from brackets on steering knuckle and frame member (Fig. 8) and (Fig. 9).
- (6) Unseat grommet that secures sensor wire in fender panel.

**Fig. 8 Sensor Wire Routing**

- (7) In engine compartment, disconnect sensor wire connector at harness plug.
- (8) Remove sensor and wire assembly.

**Fig. 9 Sensor Wire Grommet****INSTALLATION**

- (1) Apply Mopar Lock N' Seal or Loctite[®] 242 to sensor attaching bolt. Use new sensor bolt if original bolt is worn or damaged.
- (2) Position sensor on steering knuckle. Seat sensor locating tab in hole in knuckle and install sensor attaching bolt finger tight.
- (3) Tighten sensor bolt to 14 N·m (11 ft. lbs.).
- (4) Route sensor wire from steering knuckle to fender panel.
- (5) Engage grommets on sensor wire in brackets on body, chassis, frame, and steering knuckle.
- (6) Check sensor wire routing. Be sure wire is clear of all chassis components and is not twisted or kinked at any spot.
- (7) Seat sensor wire in body grommet and seat grommet in fender panel.
- (8) Connect sensor wire to harness in engine compartment.

REAR WHEEL SPEED SENSOR**REMOVAL**

- (1) Raise and fold rear seat forward. Then move carpeting aside for access to rear sensor connectors.
- (2) Disconnect rear sensor wires at harness connectors.
- (3) Push sensor wires and grommets through floorpan holes.
- (4) Raise vehicle and remove wheel and tire assembly.
- (5) Remove disc brake caliper and rotor.

REMOVAL AND INSTALLATION (Continued)

- (6) Disengage sensor wire from axle and chassis brackets and from brake line retainers.
- (7) Remove bolt attaching sensor to splash shield bracket (Fig. 10).
- (8) Remove sensor from splash shield bracket.

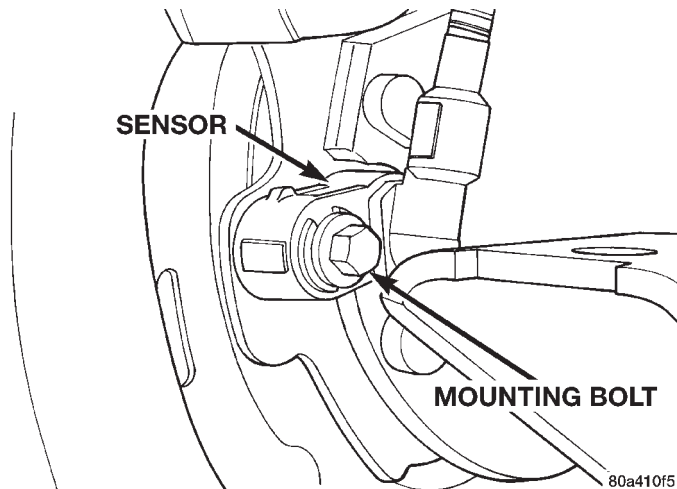


Fig. 10 Sensor Mounting Bolt

INSTALLATION

- (1) Insert sensor through splash shield hole.
- (2) Apply Mopar Lock N' Seal or Loctite 242 to original sensor bolt. Use new bolt if original is worn or damaged.
- (3) Install sensor bolt finger tight only at this time.
- (4) If **original sensor** is being installed or adjusted, remove any remaining pieces of cardboard spacer from sensor pickup face. Set air gap to 0.92 to 1.275 mm (0.036 to 0.05 in.) with feeler gauge (Fig. 11). Tighten sensor bolt to 14 N·m (11 ft. lbs.).
- (5) If **new sensor** is being installed, push cardboard spacer on sensor face against tone ring. Then tighten sensor bolt to 14 N·m (11 ft. lbs.). Correct air gap will be established as tone ring rotates and peels spacer off sensor face.
- (6) Route sensor wires to rear seat area.
- (7) Feed sensor wires through floorpan access hole and seat sensor grommets in floorpan.
- (8) Secure sensor wire in brackets and in retainers on rear brake lines. Verify that sensor wire is secure and clear of rotating components.
- (9) Install rotor, caliper and wheel, lower vehicle.
- (10) Fold rear seat and carpet forward for access to sensor wires and connectors.
- (11) Connect sensor wires to harness connectors.
- (12) Reposition carpet and fold rear seat down.

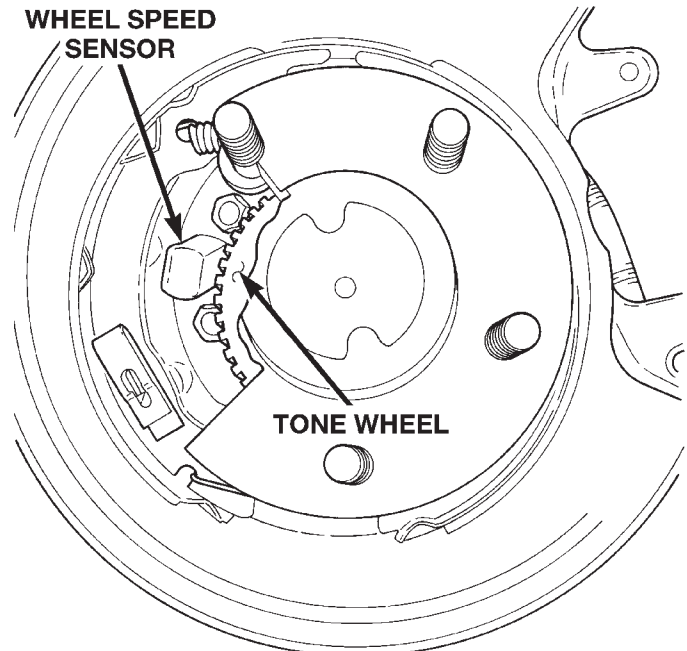


Fig. 11 Air Gap On Rear Sensor

ACCELERATION SWITCH

REMOVAL

- (1) Turn ignition switch to the OFF position.
- (2) Disconnect battery negative cable.
- (3) Fold the rear seat bottom assembly up for access to the switch.
- (4) Lift up the carpeting and disconnect switch harness (Fig. 12).
- (5) Remove bolts attaching switch to bracket and remove the switch.

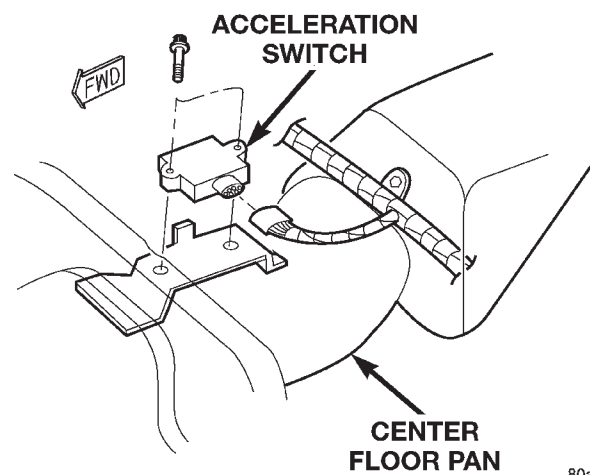


Fig. 12 Acceleration Switch Mounting

REMOVAL AND INSTALLATION (Continued)

INSTALLATION

CAUTION: The mercury switch (inside the acceleration switch), will not function properly if the switch is installed incorrectly. Verify that the switch locating arrow is pointing to the front of the vehicle (Fig. 13).

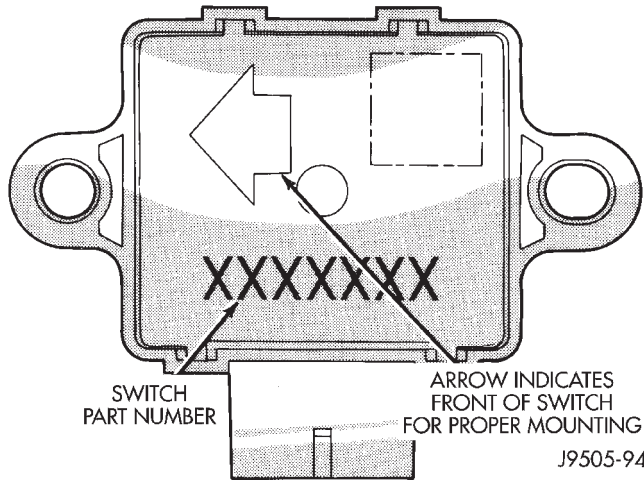


Fig. 13 Acceleration Switch

- (1) Note position of locating arrow on switch. Position switch so arrow faces forward.
- (2) Position switch in mounting bracket.
- (3) Install and tighten switch attaching bolts to 2-4 N·m (17-32 in. lbs.).
- (4) Connect harness to switch. Be sure harness connector is firmly seated.
- (5) Place the carpet in position and fold the rear seat back down.
- (6) Connect battery negative cable.

DISASSEMBLY AND ASSEMBLY

HYDRAULIC CONTROL UNIT/CONTROLLER ANTILOCK BRAKE

DISASSEMBLY

- (1) Remove pump motor connector from the CAB.

- (2) Remove CAB mounting screws from the HCU (Fig. 14).
- (3) Remove CAB from the HCU.

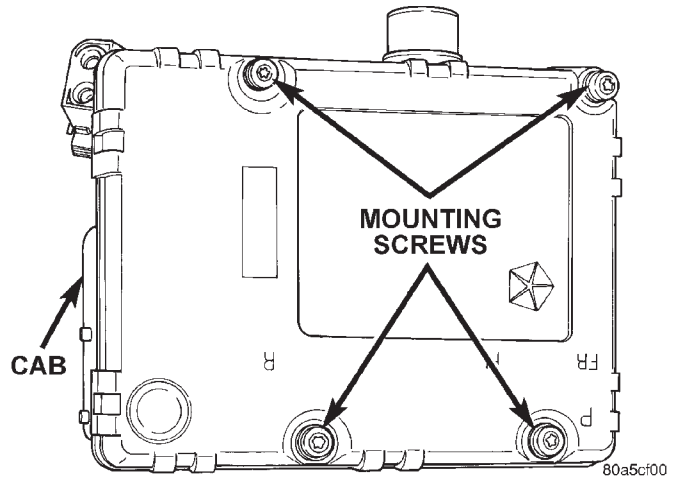


Fig. 14 CAB Mounting Screws

ASSEMBLY

- (1) Install the CAB onto the HCU.
- (2) Install the CAB mounting screws and tighten to 1.8 N·m (16 in. lbs.).
- (3) Install pump motor connector to the CAB.

SPECIFICATIONS

TORQUE CHART

DESCRIPTION	TORQUE
Acceleration Sensor	
Sensor Bolt8-9 N·m (71-83 in. lbs.)
Bracket Bolt	1-2 N·m (13-18 in. lbs.)
Hydraulic Control Unit/Controller	
Antilock Brakes	
Mounting Nuts	12 N·m (9 ft. lbs.)
Brake Lines	16 N·m (12 ft. lbs.)
CAB Screws	1.8 N·m (16 in. lbs.)
Wheel Speed Sensors	
Front Sensor Bolt	4-6 (34-50 in. lbs.)
Rear Sensor Bolt	12-14 N·m (106-124 in. lbs.)

COOLING SYSTEM

CONTENTS

	page		page
GENERAL INFORMATION			
ACCESSORY DRIVE BELTS	2	VISCOUS FAN DRIVE	21
BLOCK HEATER	2	SERVICE PROCEDURES	
COOLANT	2	COOLANT LEVEL—ROUTINE CHECK	23
COOLING SYSTEM CIRCULATION	2	COOLANT—ADDING ADDITIONAL	23
COOLING SYSTEM	1	COOLING SYSTEM—DRAINING AND FILLING ..	23
RADIATOR	2	COOLING SYSTEM—REVERSE FLUSHING ...	24
WATER PUMP BYPASS HOSE—5.2L/5.9L V-8		SERVICE COOLANT LEVEL	23
ENGINES	2	REMOVAL AND INSTALLATION	
DESCRIPTION AND OPERATION		ACCESSORY DRIVE BELT	41
ACCESSORY DRIVE BELT TENSION	4	AUTOMATIC BELT TENSIONER	43
COOLANT PERFORMANCE	5	AUTOMATIC TRANSMISSION OIL COOLER ...	25
COOLANT RESERVE/OVERFLOW SYSTEM ...	4	BLOCK HEATER	40
COOLANT SELECTION AND ADDITIVES	6	COOLING SYSTEM FAN—4.0L ENGINE	44
COOLING SYSTEM HOSES	7	COOLING SYSTEM FAN—5.2L ENGINE	45
ELECTRIC COOLING FAN—5.9L ENGINE	8	ELECTRIC COOLING FAN—5.9L ENGINE	45
BLOCK HEATER	4	RADIATOR	34
RADIATOR PRESSURE CAP	6	THERMOSTAT—4.0L ENGINE	30
THERMOSTAT	5	THERMOSTAT—5.2L/5.9L ENGINES	32
TRANSMISSION OIL COOLER	3	VISCOUS FAN DRIVE	46
VISCOUS FAN DRIVE	9	WATER PUMP BYPASS HOSE—5.2L/5.9L ...	38
WATER PUMP	7	WATER PUMP—4.0L ENGINE	25
DIAGNOSIS AND TESTING		WATER PUMP—5.2L/5.9L ENGINES	28
ACCESSORY DRIVE BELT DIAGNOSIS	11	CLEANING AND INSPECTION	
COOLING SYSTEM DIAGNOSIS	14	COOLING SYSTEM HOSES—INSPECTION ...	47
COOLING SYSTEM—TESTING FOR LEAKS ...	20	COOLING SYSTEM	46
DEAERATION	23	RADIATOR CAP—INSPECTION	46
DRB SCAN TOOL	11	RADIATOR—CLEANING	46
LOW COOLANT LEVEL-AERATION	23	VISCOUS FAN—INSPECTION	47
ON-BOARD DIAGNOSTICS (OBD)	10	WATER PUMP—INSPECTION	47
PRELIMINARY CHECKS	13	SPECIFICATIONS	
RADIATOR CAP TO FILLER NECK SEAL—		ACCESSORY DRIVE BELT TENSION	47
PRESSURE RELIEF CHECK	22	COOLING SYSTEM CAPACITIES	47
RADIATOR CAP—PRESSURE TESTING	22	TORQUE SPECIFICATIONS	48
RADIATOR COOLANT FLOW CHECK	20	SPECIAL TOOLS	
THERMOSTAT	11	COOLING	48

GENERAL INFORMATION

COOLING SYSTEM

The cooling system regulates engine operating temperature. It allows the engine to reach normal operating temperature as quickly as possible. It also

maintains normal operating temperature and prevents overheating.

The cooling system also provides a means of heating the passenger compartment and cooling the automatic transmission fluid (if equipped). The cooling

GENERAL INFORMATION (Continued)

system is pressurized and uses a centrifugal water pump to circulate coolant throughout the system.

Vehicles equipped with the 5.9L engine receive a "max" cooling package which consists of a heavy duty radiator and an electric cooling fan. This package will provide additional cooling capacity for vehicles used under extreme conditions such as trailer towing in high ambient temperatures.

Components

The cooling system consists of:

- A radiator
- Viscous Cooling Fan (4.0L/5.2L Engines)
- Electric Cooling Fan (5.9L Engines)
- Thermal viscous fan drive
- Fan shroud
- Radiator pressure cap
- Thermostat
- Coolant reserve/overflow system
- Transmission oil cooler (integral to radiator)
- Coolant
- Water pump
- Hoses and hose clamps
- Accessory drive belt

COOLING SYSTEM CIRCULATION

For cooling system flow routings refer to (Fig. 1) (Fig. 2).

RADIATOR

All vehicles are equipped with a cross flow type radiator with plastic side tanks.

Plastic tanks, while stronger than brass, are subject to damage by impact, such as from tools or wrenches. Handle radiator with care.

COOLANT

The cooling system is designed around the coolant. Coolant flows through the engine water jackets absorbing heat produced during engine operation. The coolant carries heat to the radiator and heater core. Here it is transferred to ambient air passing through the radiator and heater core fins. The coolant also removes heat from the automatic transmission fluid in vehicles equipped with an automatic transmission.

WATER PUMP BYPASS HOSE—5.2L/5.9L V-8 ENGINES

A water pump bypass hose (Fig. 3) is used between the intake manifold and water pump on all 5.2L/5.9L V-8 engines.

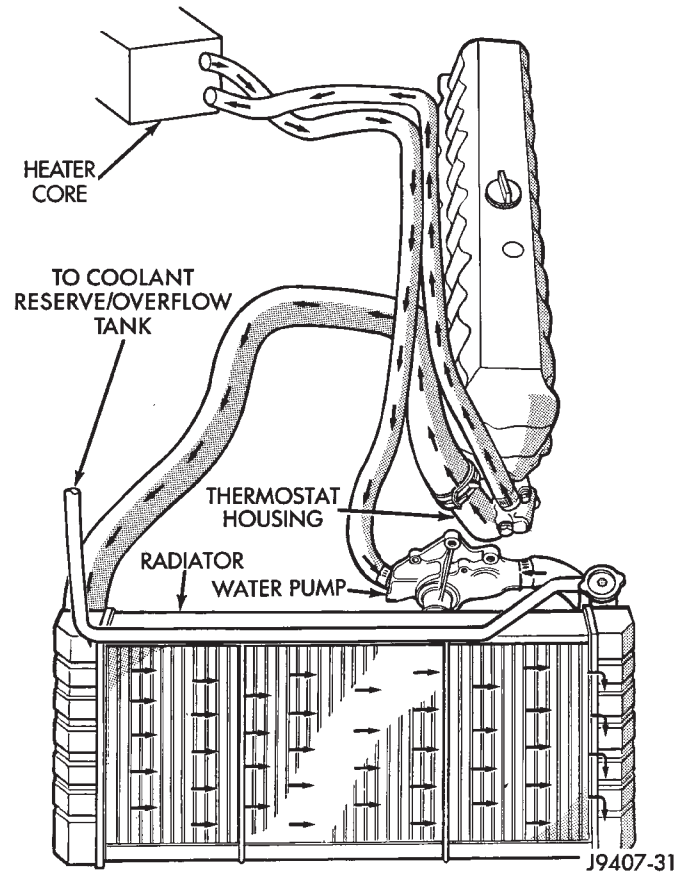


Fig. 1 Coolant Circulation—4.0L Engine

ACCESSORY DRIVE BELTS

When installing an accessory drive belt, the belt **MUST** be routed correctly. If not, the engine may overheat due to water pump rotating in wrong direction. Refer to the appropriate engine Belt Schematic in this group for the correct belt routing, or refer to the Belt Routing Label located in the engine compartment.

BLOCK HEATER

An optional engine block heater is available for all models. The heater is equipped with a power cord. The cord is attached to an engine compartment component with tie-straps. The heater warms the engine providing easier engine starting and faster warm-up in low temperatures. The heater is mounted in a core hole of the engine cylinder block (in place of a freeze plug) with the heating element immersed in engine coolant. Connect the power cord to a grounded 110-120 volt AC electrical outlet with a grounded, three-wire extension cord.

WARNING: DO NOT OPERATE ENGINE UNLESS BLOCK HEATER CORD HAS BEEN DISCONNECTED FROM POWER SOURCE AND SECURED IN PLACE.

GENERAL INFORMATION (Continued)

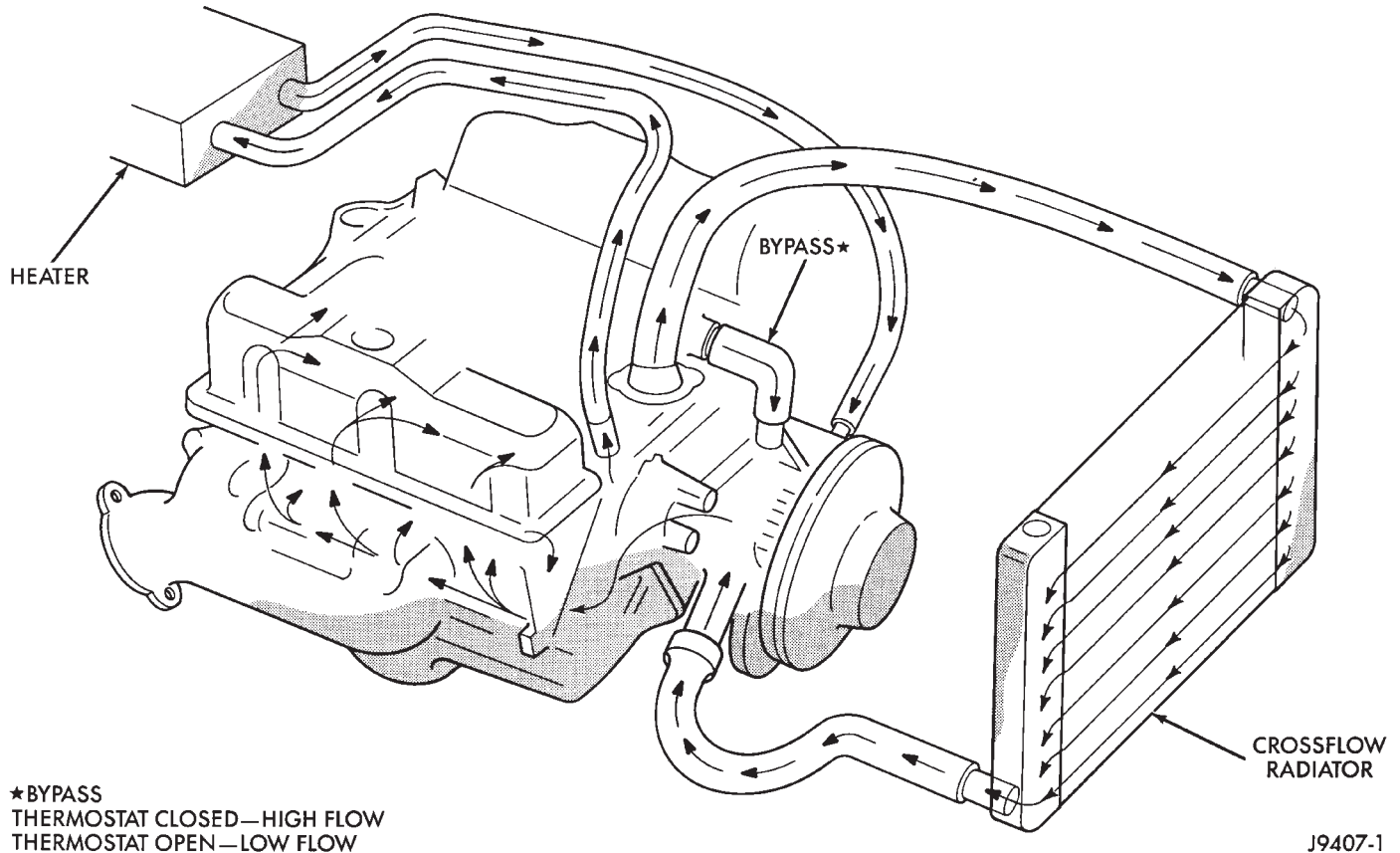


Fig. 2 Coolant Circulation—5.2/5.9L Engine

DESCRIPTION AND OPERATION

TRANSMISSION OIL COOLER

All models equipped with an automatic transmission are equipped with a transmission oil cooler (water-to-oil) mounted internally within the radiator tank. This internal cooler is supplied as standard equipment on all models equipped with an automatic transmission.

Transmission oil is cooled when it passes through this separate cooler. In case of a leak in the internal radiator mounted transmission oil cooler, engine coolant may become mixed with transmission fluid or transmission fluid may enter the cooling system. Both cooling system and transmission should be drained and inspected if the internal radiator mounted transmission cooler is leaking.

These models do not come equipped with "auxiliary" transmission air-to-oil coolers.

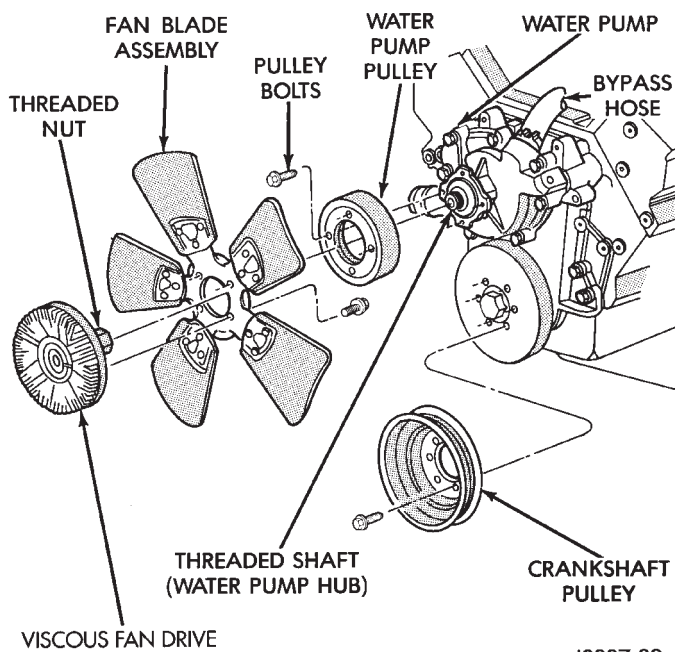


Fig. 3 Water Pump Bypass Hose—5.2L/5.9L Engines

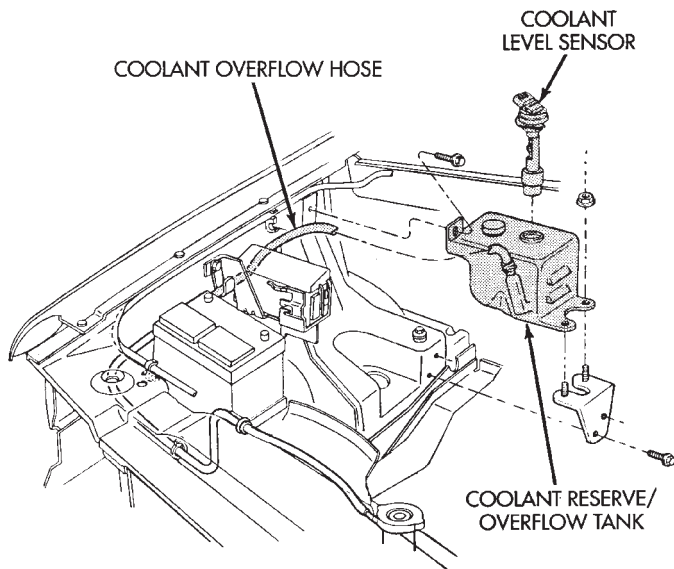
DESCRIPTION AND OPERATION (Continued)**COOLANT RESERVE/OVERFLOW SYSTEM**

This system works along with the radiator pressure cap. This is done by using thermal expansion and contraction of the coolant to keep the coolant free of trapped air. It provides:

- A volume for coolant expansion and contraction.
- A convenient and safe method for checking/adjusting coolant level at atmospheric pressure. This is done without removing the radiator pressure cap.
- Some reserve coolant to the radiator to cover minor leaks and evaporation or boiling losses.

As the engine cools, a vacuum is formed in the cooling system of both the radiator and engine. Coolant will then be drawn from the coolant tank and returned to a proper level in the radiator.

The coolant reserve/overflow system has a radiator mounted pressurized cap, an overflow tube and a plastic coolant reserve/overflow tank (Fig. 4) mounted to the right inner fender.



J9307-37

Fig. 4 Coolant Reserve/Overflow Tank—Typical

ACCESSORY DRIVE BELT TENSION

Correct drive belt tension is required to ensure optimum performance of the belt driven engine accessories. If specified tension is not maintained, belt slippage may cause; engine overheating, lack of power steering assist, loss of air conditioning capacity, reduced generator output rate, and greatly reduced belt life.

4.0L ENGINE

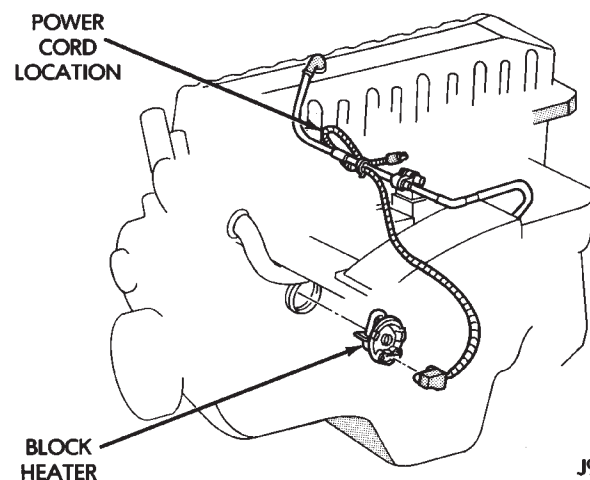
Belt tension is adjusted at the power steering pump bracket and idler pulley assembly. There are different types of adjustment gauges for checking either a serpentine or a V-type belt. Refer to the instructions supplied with the gauge. Use the correct gauge when checking belt tension. Place gauge in the middle of the section of belt being tested (between two pulleys) to check tension. Do not allow the gauge (or gauge adapter) to contact anything but the belt.

5.2L/5.9L ENGINES

It is not necessary to adjust belt tension on the 5.2L/5.9L engines. These engines are equipped with an automatic belt tensioner. The tensioner maintains correct belt tension at all times. Due to use of this belt tensioner, do not attempt to use a belt tension gauge on 5.2L/5.9L engines.

BLOCK HEATER

An optional engine block heater (Fig. 5) (Fig. 6) is available with for all models. The heater is equipped with a power cord. The cord is attached to an engine compartment component with tie-straps. The heater warms the engine providing easier engine starting and faster warm-up in low temperatures. The heater is mounted in a core hole of the engine cylinder block in place of a freeze plug with the heating element immersed in engine coolant. Connect power cord to a grounded 110-120 volt AC electrical outlet with a grounded, three wire extension cord.



J9107-47

Fig. 5 Block Heater—4.0L 6-Cyl. Engine

DESCRIPTION AND OPERATION (Continued)

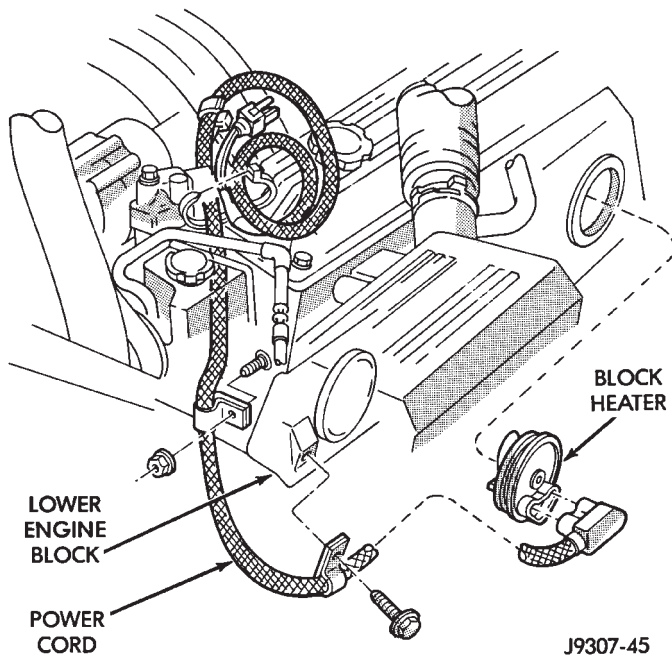


Fig. 6 Block Heater—5.2/5.9L V-8 Engines

WARNING: DO NOT OPERATE ENGINE UNLESS BLOCK HEATER CORD HAS BEEN DISCONNECTED FROM POWER SOURCE AND SECURED IN PLACE. THE POWER CORD MUST BE SECURED IN ITS RETAINING CLIPS AND ROUTED AWAY FROM EXHAUST MANIFOLDS AND MOVING PARTS.

THERMOSTAT

A pellet-type thermostat controls the operating temperature of the engine by controlling the amount of coolant flow to the radiator. On all engines the thermostat is closed below 195°F (90°C). Above this temperature, coolant is allowed to flow to the radiator. This provides quick engine warm up and overall temperature control.

An arrow, plus the word **UP** is stamped on the front flange next to the air bleed. The words **TO RAD** are stamped on one arm of the thermostat. They indicate the proper installed position.

The same thermostat is used for winter and summer seasons. An engine should not be operated without a thermostat, except for servicing or testing. Operating without a thermostat causes other problems. These are: longer engine warmup time, unreliable warmup performance, increased exhaust emissions and crankcase condensation. This condensation can result in sludge formation.

CAUTION: Do not operate an engine without a thermostat, except for servicing or testing.

The more common type of thermostat failure, usually found on high mileage vehicles, is a thermostat

failed in the shut position. The temperature gauge (if equipped) will give an indication of this condition. Depending upon length of time that vehicle is operated, pressure cap may vent. This will expel steam and coolant to coolant reserve/overflow tank and to surface below vehicle. Refer to the Diagnosis section of this group.

COOLANT PERFORMANCE

ETHYLENE-GLYCOL MIXTURES

The required ethylene-glycol (antifreeze) and water mixture depends upon the climate and vehicle operating conditions. The recommended mixture of 50/50 ethylene-glycol and water will provide protection against freezing to -37 deg. C (-35 deg. F). The antifreeze concentration **must always** be a minimum of 44 percent, year-round in all climates. **If percentage is lower than 44 percent, engine parts may be eroded by cavitation, and cooling system components may be severely damaged by corrosion.** Maximum protection against freezing is provided with a 68 percent antifreeze concentration, which prevents freezing down to -67.7 deg. C (-90 deg. F). A higher percentage will freeze at a warmer temperature. Also, a higher percentage of antifreeze can cause the engine to overheat because the specific heat of antifreeze is lower than that of water.

100 Percent Ethylene-Glycol—Should Not Be Used in Chrysler Vehicles

Use of 100 percent ethylene-glycol will cause formation of additive deposits in the system, as the corrosion inhibitive additives in ethylene-glycol require the presence of water to dissolve. The deposits act as insulation, causing temperatures to rise to as high as 149 deg. C (300 deg. F). This temperature is hot enough to melt plastic and soften solder. The increased temperature can result in engine detonation. In addition, 100 percent ethylene-glycol freezes at 22 deg. C (-8 deg. F).

Propylene-glycol Formulations—Should Not Be Used in Chrysler Vehicles

Propylene-glycol formulations do not meet Chrysler coolant specifications. Its overall effective temperature range is smaller than that of ethylene-glycol. The freeze point of 50/50 propylene-glycol and water is -32 deg. C (-26 deg. F), 5 deg. C higher than ethylene-glycol's freeze point. The boiling point (protection against summer boil-over) of propylene-glycol is 125 deg. C (257 deg. F) at 96.5 kPa (14 psi), compared to 128 deg. C (263 deg. F) for ethylene-glycol. Use of propylene-glycol can result in boil-over or freeze-up in Chrysler vehicles, which are designed for ethylene-glycol. Propylene glycol also has poorer heat transfer characteristics than ethylene glycol. This

DESCRIPTION AND OPERATION (Continued)

can increase cylinder head temperatures under certain conditions.

Propylene-glycol/Ethylene-glycol Mixtures—Should Not Be Used in Chrysler Vehicles

Propylene-glycol/ethylene-glycol Mixtures can cause the destabilization of various corrosion inhibitors, causing damage to the various cooling system components. Also, once ethylene-glycol and propylene-glycol based coolants are mixed in the vehicle, conventional methods of determining freeze point will not be accurate. Both the refractive index and specific gravity differ between ethylene glycol and propylene glycol.

CAUTION: Richer antifreeze mixtures cannot be measured with normal field equipment and can cause problems associated with 100 percent ethylene-glycol.

COOLANT SELECTION AND ADDITIVES

The presence of aluminum components in the cooling system requires strict corrosion protection. Maintain coolant at specified level with a mixture of ethylene-glycol based antifreeze and water. Chrysler Corporation recommends Mopar Antifreeze or equivalent. If coolant becomes contaminated or loses color, drain and flush cooling system and fill with correctly mixed solution.

A 0.25 percent emulsifiable oil is added to the radiator at the factory to prevent solder corrosion.

CAUTION: Do not use coolant additives that are claimed to improve engine cooling.

RADIATOR PRESSURE CAP

All radiators are equipped with a pressure cap. This cap releases pressure at some point within a range of 97-to-124 kPa (14-to-18 psi). The pressure relief point (in pounds) is engraved on top of the cap (Fig. 7).

The cooling system will operate at pressures slightly above atmospheric pressure. This results in a higher coolant boiling point allowing increased radiator cooling capacity. The cap (Fig. 7) contains a spring-loaded pressure relief valve. This valve opens when system pressure reaches the release range of 97-to-124 kPa (14-to-18 psi).

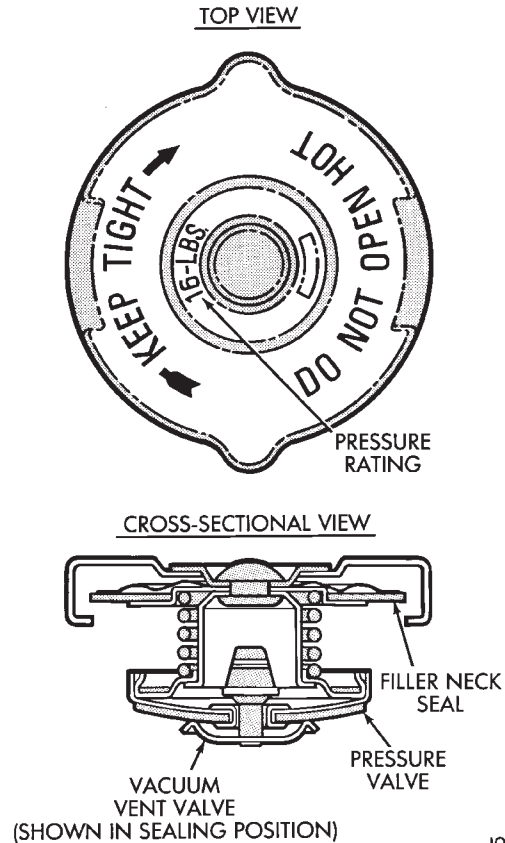


Fig. 7 Radiator Pressure Cap—Typical

A vent valve in the center of the cap allows a small coolant flow through the cap when coolant is below boiling temperature. The valve is completely closed when boiling point is reached. As the coolant cools, it contracts and creates a vacuum in cooling system. This causes the vacuum valve to open and coolant in reserve/overflow tank to be drawn through connecting hose into radiator. If the vacuum valve is stuck shut, radiator hoses will collapse on cool-down.

A rubber gasket seals the radiator filler neck. This is done to maintain vacuum during coolant cool-down and to prevent leakage when system is under pressure.

DESCRIPTION AND OPERATION (Continued)

WATER PUMP

A centrifugal water pump circulates coolant through the water jackets, passages, intake manifold, radiator core, cooling system hoses and heater core. The pump is driven from the engine crankshaft by a single serpentine drive belt on all engines.

The water pump impeller is pressed onto the rear of a shaft that rotates in bearings pressed into the housing. The housing has two small holes to allow seepage to escape. The water pump seals are lubricated by the antifreeze in the coolant mixture. No additional lubrication is necessary.

CAUTION: All 4.0L 6-cylinder engines are equipped with a reverse (counterclockwise) rotating water pump and thermal viscous fan drive assembly. **REVERSE** is stamped or imprinted on the cover of the viscous fan drive and inner side of the fan. The letter **R** is stamped into the back of the water pump impeller (Fig. 8). Engines from previous model years, depending upon application, may have been equipped with a forward (clockwise) rotating water pump. Installation of the wrong water pump or viscous fan drive will cause engine over heating.

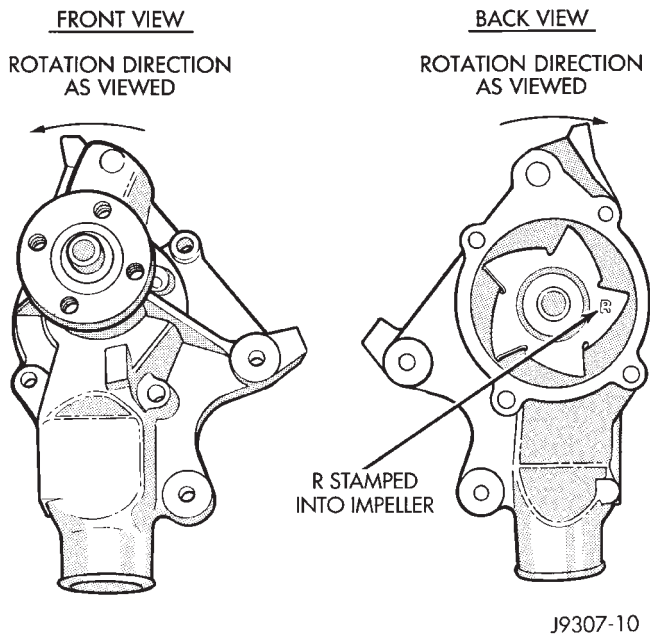


Fig. 8 Reverse Rotating Water Pump—4.0L 6-Cylinder

A quick test to determine if the pump is working is to check if the heater warms properly. A defective water pump will not be able to circulate heated coolant through the long heater hose to the heater core.

5.2/5.9L ENGINES: One of the heater hoses is connected to the water pump with a metal coolant return tube (Fig. 9). A rubber o-ring forms a seal at the water pump end of the tube.

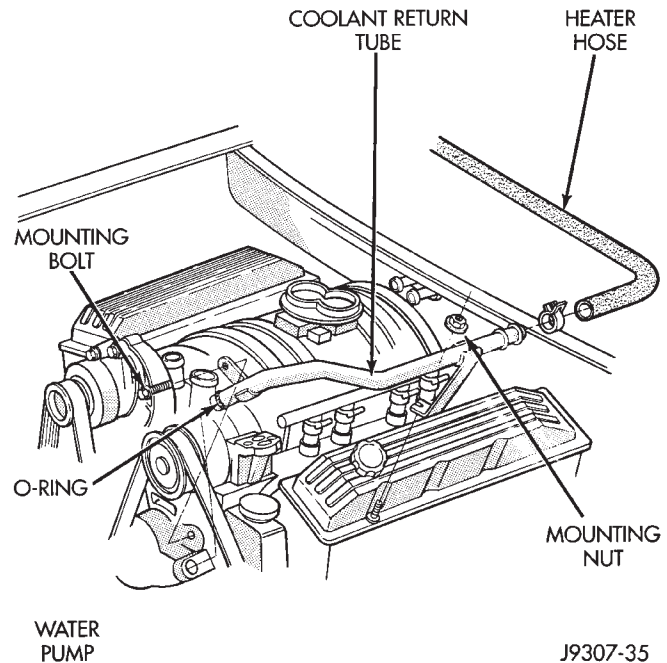


Fig. 9 Coolant Return Tube—5.2/5.9L V-8 Engines

COOLING SYSTEM HOSES

Rubber hoses route coolant to and from the radiator, intake manifold and heater core. The lower radiator hose is spring-reinforced to prevent collapse from water pump suction at moderate and high engine speeds.

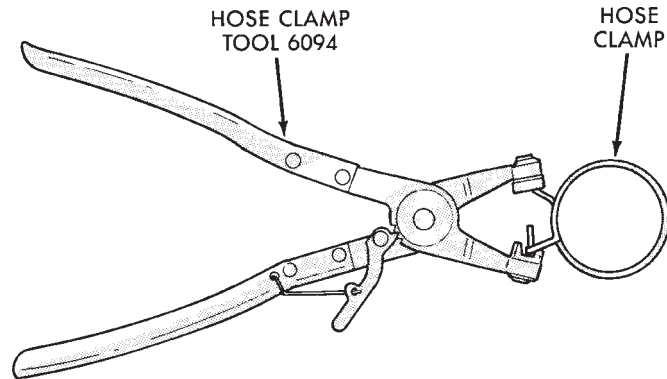
Vehicles equipped with the 5.9L engine and an the "max" cooling package (electric fan) have radiator upper and lower hoses consisting of stainless steel "tees" located between two hoses. The tees house the electric cooling fan low and high speed switches and can only be serviced by replacing the hose assembly.

WARNING: CONSTANT TENSION HOSE CLAMPS ARE USED ON MOST COOLING SYSTEM HOSES. WHEN REMOVING OR INSTALLING, USE ONLY TOOLS DESIGNED FOR SERVICING THIS TYPE OF CLAMP, SUCH AS SPECIAL CLAMP TOOL (NUMBER 6094) (Fig. 10). SNAP-ON CLAMP TOOL (NUMBER HPC-20) MAY BE USED FOR LARGER CLAMPS. ALWAYS WEAR SAFETY GLASSES WHEN SERVICING CONSTANT TENSION CLAMPS.

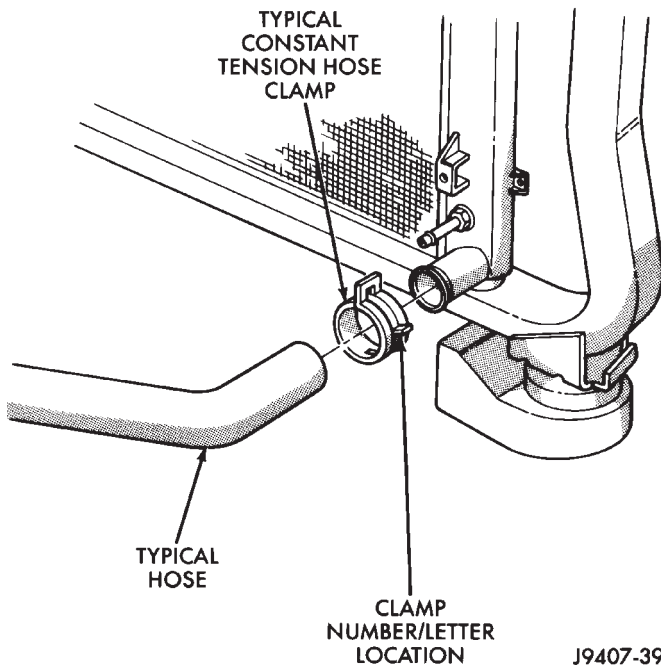
DESCRIPTION AND OPERATION (Continued)

CAUTION: A number or letter is stamped into the tongue of constant tension clamps (Fig. 11). If replacement is necessary, use only an original equipment clamp with matching number or letter.

Inspect the hoses at regular intervals. Replace hoses that are cracked, feel brittle when squeezed, or swell excessively when the system is pressurized.



J9207-36

Fig. 10 Hose Clamp Tool—Typical

J9407-39

Fig. 11 Clamp Number/Letter Location

For all vehicles: In areas where specific routing clamps are not provided, be sure that hoses are positioned with sufficient clearance. Check clearance from exhaust manifolds and pipe, fan blades, drive belts and sway bars. Improperly positioned hoses can be damaged, resulting in coolant loss and engine overheating.

Ordinary worm gear type hose clamps (when equipped) can be removed with a straight screwdriver or a hex socket. **To prevent damage to hoses or clamps, the hose clamps should be tightened to 4 N·m (34 in. lbs.) torque. Do not over tighten hose clamps.**

When performing a hose inspection, inspect the radiator lower hose for proper position and condition of the internal spring.

ELECTRIC COOLING FAN—5.9L ENGINE

Vehicles equipped with the 5.9L engine receive a "max" cooling package which consists of a heavy duty radiator and an electric cooling fan. This fan can only be serviced as an assembly.

This is a two speed fan (low and high) which is controlled by an ignition relay, low and high speed fan relays (Fig. 12), upper and lower hose coolant temperature switches (Fig. 13) and the A/C high-pressure switch. Refer to Group 8W, Wiring Diagrams for the system schematic.

The relays and their control circuits are protected by a 15 amp fuse in the PDC. The electric fan motor and its circuits are protected by a 60 amp "maxi-fuse" also located in the PDC (Fig. 14). Refer to the inside of the PDC cover for exact fuse position.

The cooling fan low and high speed relays are mounted to the passenger inner fender next to the battery (Fig. 12). The relays can be identified by tags on the harness marked "HI" and "LOW".

CIRCUIT OPERATION

The ignition relay provides battery voltage to the low speed fan relay winding when the ignition key is in the start or run position. It also provides battery voltage to the high speed fan relay winding when the key is in the start or run position **and** the lower hose coolant temperature switch is closed. This relay is located under the Power Distribution Center (PDC), mounted to the PDC bracket.

The low speed cooling fan relay is energized when the ignition key is "on" **and** the upper hose coolant temperature switch is closed **or** the A/C is "on" and the high pressure switch closes. This provides battery voltage to the low speed terminal of the cooling fan motor and the cooling fan comes on low speed.

DESCRIPTION AND OPERATION (Continued)

The high speed cooling fan relay is energized when the ignition key is on **and** the lower hose coolant temperature sensor is closed. This provides battery voltage to the high terminal of the cooling fan motor and the cooling fan comes on high speed.

COOLING FAN OPERATION CHART

COOLANT TEMP	A/C	UPPER HOSE SWITCH	LOWER HOSE SWITCH	FAN
-36° - 213°F	OFF	OPEN	OPEN	OFF
214° - 219°F	OFF	CLOSED	OPEN	ON/LOW
220°F AND UP	OFF	CLOSED	CLOSED	ON/HIGH
-36° - 213°F	ON	OPEN	OPEN	ON/LOW
214° - 219°F	ON	CLOSED	OPEN	ON/LOW
220°F AND UP	ON	CLOSED	CLOSED	ON/HIGH

WARNING: THE FAN CAN COME ON AT ANY TIME WHEN THE IGNITION KEY IS IN THE "RUN" POSITION.

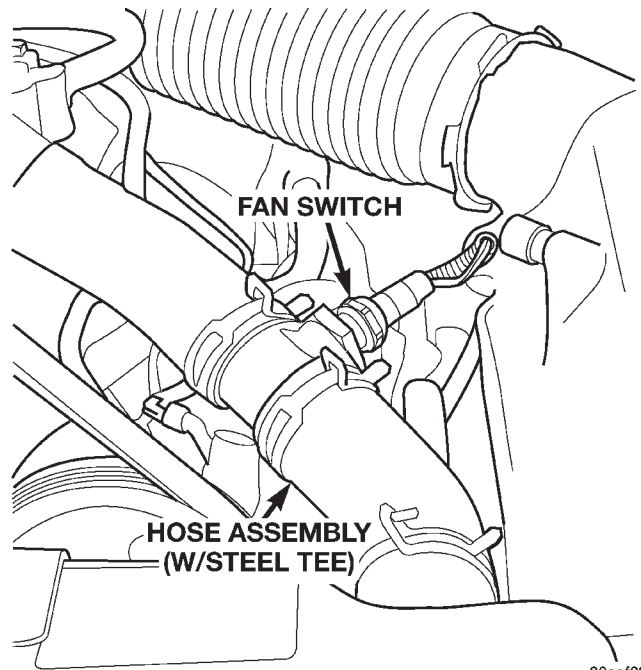


Fig. 13 Radiator Hose Coolant Temperature Switch—Typical

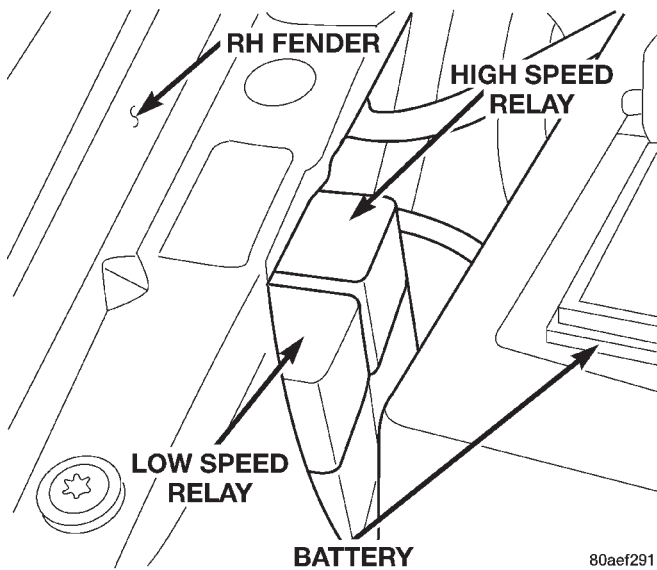


Fig. 12 Cooling Fan Low and High Speed Relay

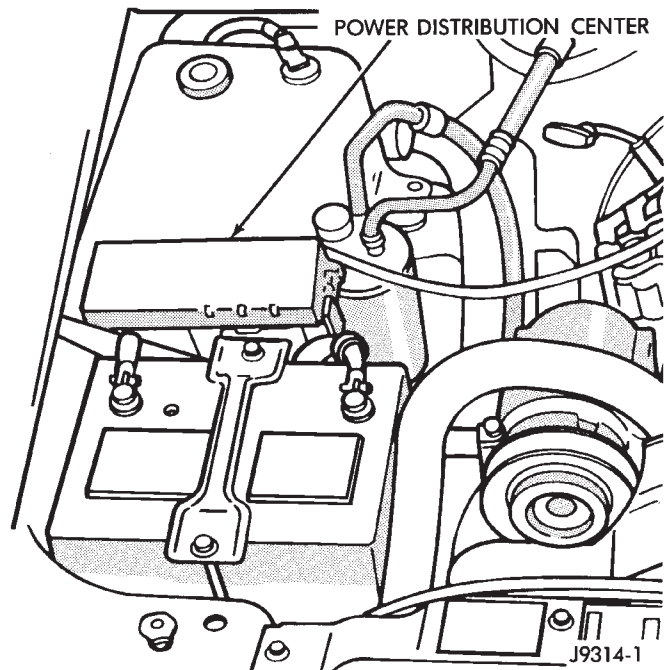


Fig. 14 Power Distribution Center—PDC

VISCOUS FAN DRIVE

The thermal viscous fan drive (Fig. 15) (Fig. 16) is a silicone-fluid-filled coupling used to connect the fan blades to the water pump shaft. The coupling allows the fan to be driven in a normal manner. This is done at low engine speeds while limiting the top speed of the fan to a predetermined maximum level at higher engine speeds.

DESCRIPTION AND OPERATION (Continued)

A thermostatic bimetallic spring coil is located on the front face of the viscous fan drive unit (Fig. 15) (Fig. 16). This spring coil reacts to the temperature of the radiator discharge air. It engages the viscous fan drive for higher fan speed if the air temperature from the radiator rises above a certain point. Until additional engine cooling is necessary, the fan will remain at a reduced rpm regardless of engine speed.

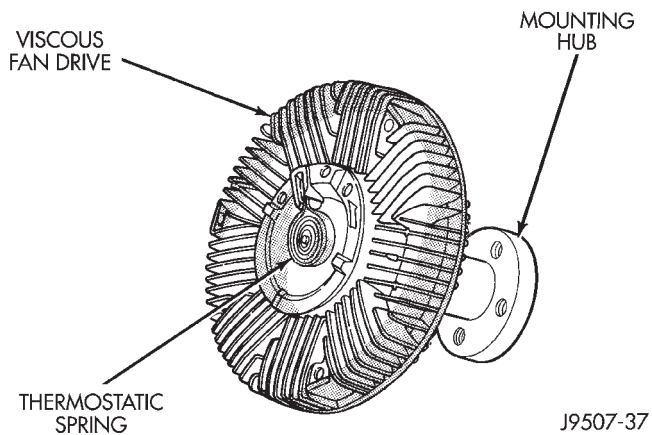


Fig. 15 Viscous Fan Drive—4.0L Engine—Typical

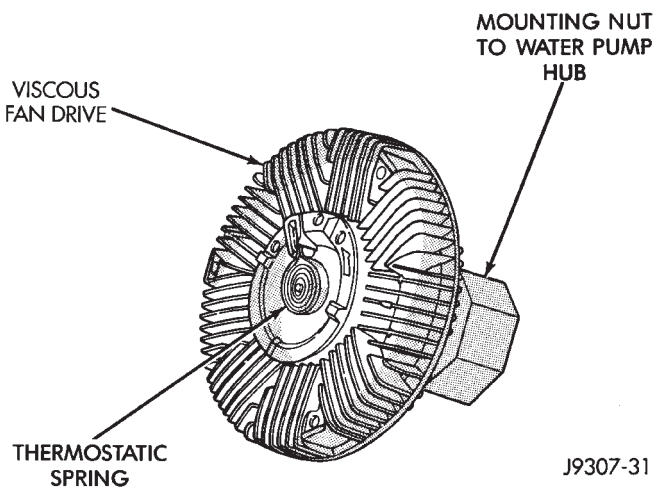


Fig. 16 Viscous Fan Drive—5.2/5.9L Engines—Typical

Only when sufficient heat is present, will the viscous fan drive engage. This is when the air flowing through the radiator core causes a reaction to the bimetallic coil. It then increases fan speed to provide the necessary additional engine cooling.

Once the engine has cooled, the radiator discharge temperature will drop. The bimetallic coil again reacts and the fan speed is reduced to the previous disengaged speed.

CAUTION: Engines equipped with serpentine drive belts have reverse rotating fans and viscous fan

drives. They are marked with the word **REVERSE** to designate their usage. Installation of the wrong fan or viscous fan drive can result in engine overheating.

CAUTION: If the viscous fan drive is replaced because of mechanical damage, the cooling fan blades should also be inspected. Inspect for fatigue cracks, loose blades, or loose rivets that could have resulted from excessive vibration. Replace fan blade assembly if any of these conditions are found. Also inspect water pump bearing and shaft assembly for any related damage due to a viscous fan drive malfunction.

NOISE

NOTE: It is normal for fan noise to be louder (roaring) when:

- The underhood temperature is above the engagement point for the viscous drive coupling. This may occur when ambient (outside air temperature) is very high.
- Engine loads and temperatures are high such as when towing a trailer.
- Cool silicone fluid within the fan drive unit is being redistributed back to its normal disengaged (warm) position. This can occur during the first 15 seconds to one minute after engine start-up on a cold engine.

LEAKS

Viscous fan drive operation is not affected by small oil stains near the drive bearing. If leakage appears excessive, replace the fan drive unit.

DIAGNOSIS AND TESTING**ON-BOARD DIAGNOSTICS (OBD)****COOLING SYSTEM RELATED DIAGNOSTICS**

The Powertrain Control Module (PCM) has been programmed to monitor the certain following cooling system components:

- If the engine has remained cool for too long a period, such as with a stuck open thermostat, a Diagnostic Trouble Code (DTC) can be set.
- If an open or shorted condition has developed in the relay circuit controlling the electric radiator fan, a Diagnostic Trouble Code (DTC) can be set.

If the problem is sensed in a monitored circuit often enough to indicate an actual problem, a DTC is stored. The DTC will be stored in the PCM memory for eventual display to the service technician. (Refer

DIAGNOSIS AND TESTING (Continued)

to Group 25, Emission Control Systems for proper procedures)

ACCESSING DIAGNOSTIC TROUBLE CODES

To read DTC's and to obtain cooling system data, refer to Group 25, Emission Control Systems for proper procedures.

DRB SCAN TOOL

For operation of the DRB scan tool, refer to the appropriate Powertrain Diagnostic Procedures service manual.

THERMOSTAT

ON-BOARD DIAGNOSTICS

All models are equipped with On-Board Diagnostics for certain cooling system components. Refer to On-Board Diagnostics (OBD) in the Diagnosis section of this group for additional information. If the powertrain control module (PCM) detects low engine coolant temperature, it will record a Diagnostic Trouble Code (DTC) in the PCM memory. Refer to the Diagnosis section of this group for other probable causes. For other DTC numbers, refer to On-Board Diagnostics in Group 25, Emission Control Systems.

The DTC can also be accessed through the DRB scan tool. Refer to the appropriate Powertrain Diagnostic Procedures manual for diagnostic information and operation of the DRB scan tool.

ACCESSORY DRIVE BELT DIAGNOSIS

VISUAL DIAGNOSIS

When diagnosing serpentine accessory drive belts, small cracks that run across the ribbed surface of the belt from rib to rib (Fig. 17), are considered normal. These are not a reason to replace the belt. However, cracks running along a rib (not across) are **not** normal. Any belt with cracks running along a rib must be replaced (Fig. 17). Also replace the belt if it has excessive wear, frayed cords or severe glazing.

Refer to the Accessory Drive Belt Diagnosis charts for further belt diagnosis.

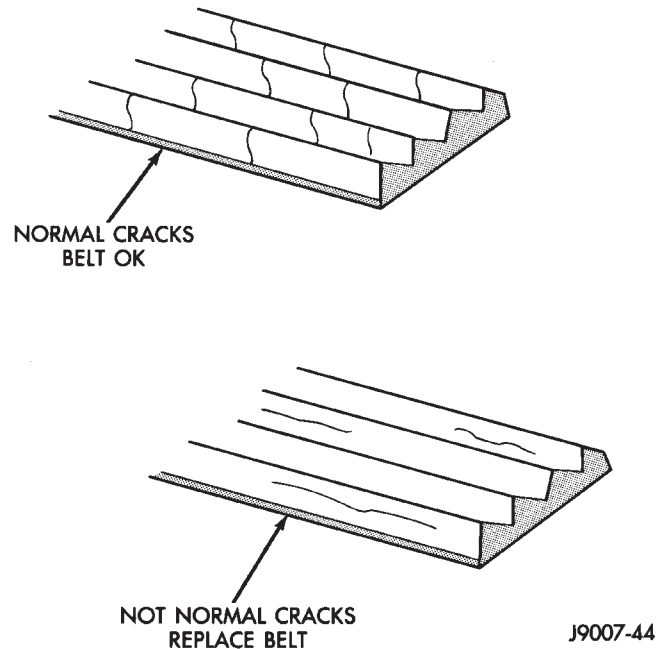


Fig. 17 Belt Wear Patterns

NOISE DIAGNOSIS

Noises generated by the accessory drive belt are most noticeable at idle. Before replacing a belt to resolve a noise condition, inspect all of the accessory drive pulleys for alignment, glazing, or excessive end play.

DIAGNOSIS AND TESTING (Continued)**ACCESSORY DRIVE BELT DIAGNOSIS CHART**

CONDITION	POSSIBLE CAUSES	CORRECTION
RIB CHUNKING (One or more ribs has separated from belt body)	<ol style="list-style-type: none"> 1. Foreign objects imbedded in pulley grooves. 2. Installation damage 	<ol style="list-style-type: none"> 1. Remove foreign objects from pulley grooves. Replace belt. 2. Replace belt
RIB OR BELT WEAR	<ol style="list-style-type: none"> 1. Pulley misaligned 2. Abrasive environment 3. Rusted pulley(s) 4. Sharp or jagged pulley groove tips 5. Belt rubber deteriorated 	<ol style="list-style-type: none"> 1. Align pulley(s) 2. Clean pulley(s). Replace belt if necessary 3. Clean rust from pulley(s) 4. Replace pulley. Inspect belt. 5. Replace belt
BELT SLIPS	<ol style="list-style-type: none"> 1. Belt slipping because of insufficient tension 2. Belt or pulley exposed to substance that has reduced friction (belt dressing, oil, ethylene glycol) 3. Driven component bearing failure (seizure) 4. Belt glazed or hardened from heat and excessive slippage 	<ol style="list-style-type: none"> 1. Adjust tension (4.0L). Replace tensioner (5.2L/5.9L Engines) 2. Replace belt and clean pulleys 3. Replace faulty component or bearing 4. Replace belt.
LONGITUDAL BELT CRACKING	<ol style="list-style-type: none"> 1. Belt has mistracked from pulley groove 2. Pulley groove tip has worn away rubber to tensile member 	<ol style="list-style-type: none"> 1. Replace belt 2. Replace belt
"GROOVE JUMPING" (Belt does not maintain correct position on pulley)	<ol style="list-style-type: none"> 1. Belt tension either too low or too high 2. Pulley(s) not within design tolerance 3. Foreign object(s) in grooves 4. Pulley misalignment 5. Belt cordline is broken 	<ol style="list-style-type: none"> 1. Adjust belt tension (4.0L). Replace tensioner (5.2L/5.9L Engines) 2. Replace pulley(s) 3. Remove foreign objects from grooves 4. Align component 5. Replace belt
BELT BROKEN (Note: Identify and correct problem before new belt is installed)	<ol style="list-style-type: none"> 1. Excessive tension (4.0L) 2. Tensile member damaged during belt installation 3. Severe misalignment 4. Bracket, pulley, or bearing failure 	<ol style="list-style-type: none"> 1. Replace belt and adjust tension to specification 2. Replace belt 3. Align pulley(s) 4. Replace defective component and belt

DIAGNOSIS AND TESTING (Continued)

CONDITION	POSSIBLE CAUSES	CORRECTION
NOISE (Objectionable squeal, squeak, or rumble is heard or felt while drive belt is in operation)	1. Belt slippage 2. Bearing noise 3. Belt misalignment 4. Belt to pulley mismatch 5. Driven component induced vibration 6. System resonant frequency induced vibration	1. Adjust belt (4.0L). Replace tensioner (5.2L/5.9L Engines) 2. Locate and repair 3. Align belt/pulley(s) 4. Install correct belt 5. Locate defective driven component and repair 6. Vary belt tension within specifications.
TENSION SHEETING FABRIC FAILURE (Woven fabric on outside, circumference of belt has cracked or separated from body of belt)	1. Tension sheeting contacting stationary object 2. Excessive heat causing woven fabric to age 3. Tension sheeting splice has fractured	1. Correct rubbing condition 2. Replace belt 3. Replace belt
CORD EDGE FAILURE (Tensile member exposed at edges of belt or separated from belt body)	1. Excessive tension 2. Belt contacting stationary object 3. Pulley(s) out of tolerance 4. Insufficient adhesion between tensile member and rubber matrix	1. Adjust belt tension (4.0L). Replace tensioner (5.2L/5.9L Engines) 2. Replace belt 3. Replace pulley 4. Replace belt and adjust tension to specifications

PRELIMINARY CHECKS**ENGINE COOLING SYSTEM OVERHEATING**

Establish what driving conditions caused the complaint. Abnormal loads on the cooling system such as the following may be the cause.

PROLONGED IDLE, VERY HIGH AMBIENT TEMPERATURE, SLIGHT TAIL WIND AT IDLE, SLOW TRAFFIC, TRAFFIC JAMS, HIGH SPEED, OR STEEP GRADES:

Driving techniques that avoid overheating are:

- Idle with A/C off when temperature gauge is at end of normal range.
- Increasing engine speed for more air flow is recommended.

TRAILER TOWING

Consult Trailer Towing section of owners manual. Do not exceed limits.

AIR CONDITIONING; ADD-ON OR AFTER MARKET

These models are equipped with a "heavy duty" cooling system and therefore will accommodate add-on or aftermarket air conditioning. No modifications are necessary to the cooling system.

RECENT SERVICE OR ACCIDENT REPAIR:

Determine if any recent service has been performed on vehicle that may effect cooling system. This may be:

- Engine adjustments (incorrect timing)
- Slipping engine accessory drive belt(s)
- Brakes (possibly dragging)
- Changed parts (incorrect water pump rotating in wrong direction)
- Reconditioned radiator or cooling system refilling (possibly under-filled or air trapped in system).

NOTE: If investigation reveals none of the previous items as a cause for an engine overheating complaint, refer to following Cooling System Diagnosis charts.

DIAGNOSIS AND TESTING (Continued)**COOLING SYSTEM DIAGNOSIS****COOLING SYSTEM DIAGNOSIS CHART**

CONDITION	POSSIBLE CAUSES	CORRECTION
TEMPERATURE GAUGE READS LOW	<ol style="list-style-type: none"> 1. Has a Diagnostic Trouble Code (DTC) been set indicating a stuck open engine thermostat. 2. Is the temperature gauge (if equipped) connected to the temperature gauge coolant sensor on the engine? 3. Is the temperature gauge (if equipped) operating OK? 4. Coolant level low in cold ambient temperatures accompanied with poor heater performance. 5. Improper operation of internal heater doors or heater controls. 	<ol style="list-style-type: none"> 1. Refer to group 25, Emission Control Systems. Replace thermostat if necessary. If a Diagnostic Trouble Code (DTC) has not been set, the problem may be with the temperature gauge. 2. Check the engine temperature sensor connector in the engine compartment. Refer to Group 8E. Repair as necessary. 3. Check gauge operation. Refer to Group 8E. Repair as necessary. 4. Check coolant level in the coolant reserve/overflow tank and the radiator. Inspect system for leaks. Repair leaks as necessary. Refer to the Coolant section of the manual text for Warnings and precautions before removing the radiator cap. 5. Inspect heater and repair as necessary. Refer to Group 24, Heating and Air Conditioning for procedures.
TEMPERATURE GAUGE READS HIGH OR ENGINE COOLANT WARNING LAMP ILLUMINATES. COOLANT MAY OR MAY NOT BE LOST OR LEAKING FROM COOLING SYSTEM	<ol style="list-style-type: none"> 1. Trailer is being towed, a steep hill is being climbed, vehicle is operated in slow moving traffic, or engine is being idled with very high ambient (outside) temperatures and the air conditioning is on. Higher altitudes could aggravate these conditions. 2. Is temperature gauge (if equipped) reading correctly? 3. Is temperature warning lamp (if equipped) illuminating unnecessarily? 4. Coolant low in coolant reserve/overflow tank and radiator? 	<ol style="list-style-type: none"> 1. This may be a temporary condition and repair is not necessary. Turn off the air conditioning and attempt to drive the vehicle without any of the previous conditions. Observe the temperature gauge. The gauge should return to the normal range. If the gauge does not return to normal range, determine the cause for overheating and repair. Refer to POSSIBLE CAUSES (numbers 2 through 18). 2. Check gauge. Refer to Group 8E. Repair as necessary. 3. Check warning lamp operation. Refer to Group 8E. Repair as necessary. 4. Check for coolant leaks and repair as necessary. Refer to Testing Cooling System for Leaks in this group.

DIAGNOSIS AND TESTING (Continued)

CONDITION	POSSIBLE CAUSES	CORRECTION
<p>TEMPERATURE GAUGE READS HIGH OR ENGINE COOLANT WARNING LAMP ILLUMINATES. COOLANT MAY OR MAY NOT BE LOST OR LEAKING FROM COOLING SYSTEM</p>	<p>5. Pressure cap not installed tightly. If cap is loose, boiling point of coolant will be lowered. Also refer to the following step 6.</p> <p>6. Poor seals at radiator cap.</p> <p>7. Coolant level low in radiator but not in coolant reserve/overflow tank. This means the radiator is not drawing coolant from the coolant reserve/overflow tank as the engine cools. As the engine cools, a vacuum is formed in the cooling system of the engine and radiator. If radiator cap seals are defective, or cooling system has leaks, a vacuum can not be formed.</p> <p>8. Freeze point of antifreeze not correct. Mixture may be too rich.</p> <p>9. Coolant not flowing through system.</p> <p>10. Radiator or A/C condenser fins are dirty or clogged.</p> <p>11. Radiator core is corroded or plugged.</p> <p>12. Fuel or ignition system problems.</p> <p>13. Dragging brakes.</p> <p>14. Bug screen is being used reducing airflow.</p>	<p>5. Tighten cap.</p> <p>6. (a) Check condition of cap and cap seals. Refer to Radiator Cap. Replace cap if necessary. (b) Check condition of radiator filler neck. If neck is bent or damaged, replace radiator.</p> <p>7. (a) Check condition of radiator cap and cap seals. Refer to Radiator Cap in this group. Replace cap if necessary. (b) Check condition of radiator filler neck. If neck is bent or damaged, replace radiator. (c) Check the condition of the hose from the radiator to the coolant tank. It should fit tight at both ends without any kinks or tears. Replace hose if necessary. (d) Check coolant reserve/overflow tank and tank hoses for blockage. Repair as necessary</p> <p>8. Check antifreeze. Refer to Coolant section of this group. Adjust antifreeze-to-water ratio as required.</p> <p>9. Check for coolant flow at radiator filler neck with some coolant removed, engine warm and thermostat open. Coolant should be observed flowing through radiator. If flow is not observed, determine reason for lack of flow and repair as necessary.</p> <p>10. Clean insects or debris. Refer to Radiator Cleaning in this group.</p> <p>11. Have radiator re-cored or replaced.</p> <p>12. Refer to Fuel and Ignition System groups for diagnosis. Also refer to the appropriate Powertrain Diagnostic Procedures service manual for operation of the DRB scan tool.</p> <p>13. Check and correct as necessary. Refer to Group 5, Brakes in the manual text.</p> <p>14. Remove bug screen.</p>

DIAGNOSIS AND TESTING (Continued)

CONDITION	POSSIBLE CAUSES	CORRECTION
TEMPERATURE GAUGE READS HIGH OR ENGINE COOLANT WARNING LAMP ILLUMINATES. COOLANT MAY OR MAY NOT BE LOST OR LEAKING FROM COOLING SYSTEM	<p>15. Thermostat partially or completely shut. This is more prevalent of high mileage vehicles.</p> <p>16. Thermal viscous fan drive not operating properly.</p> <p>17. Cylinder head gasket leaking.</p> <p>18. Heater core leaking.</p>	<p>15. Check thermostat operation and replace as necessary. Refer to Thermostats in this group.</p> <p>16. Check fan drive operation and replace if necessary. Refer to Viscous Fan Drive in this group.</p> <p>17. Check for cylinder head gasket leaks. Refer to Testing Cooling System for Leaks in this group. For repair, refer to Group 9, Engines.</p> <p>18. Check heater core for leaks. Refer to Group 24, Heating and Air Conditioning. Repair as necessary.</p>
TEMPERATURE GAUGE READING IS INCONSISTENT (FLUCTUATES, CYCLES OR IS ERRATIC)	<p>1. During cold weather operation, with the heater blower in the high position, the gauge reading may drop slightly.</p> <p>2. Temperature gauge or engine mounted gauge sensor defective or shorted. Also, corroded or loose wiring in the circuit.</p> <p>3. Gauge reading rises when vehicle is brought to a stop after heavy use (engine still running).</p> <p>4. Gauge reading high after restarting a warmed-up (hot) engine.</p> <p>5. Coolant level low in radiator (air will build up in the cooling system causing the thermostat to open late).</p> <p>6. Cylinder head gasket leaking allowing exhaust gas to enter cooling system causing thermostat to open late.</p> <p>7. Water pump impeller loose on shaft.</p> <p>8. Loose accessory drive belt (water pump slipping).</p> <p>9. Air leak on the suction side of water pump allows air to build up in cooling system causing thermostat to open late.</p>	<p>1. A normal condition. No correction is necessary.</p> <p>2. Check operation of gauge and repair if necessary. Refer to Group 8E, Instrument Panel and Gauges.</p> <p>3. A normal condition. No correction is necessary. Gauge reading should return to normal range after vehicle is driven.</p> <p>4. A normal condition. No correction is necessary. The gauge should return to normal range after a few minutes of engine operation.</p> <p>5. Check and correct coolant leaks. Refer to Testing Cooling System for Leaks in this group.</p> <p>6. (a) Check for cylinder head gasket leaks with a commercially available Block Leak Tester. Repair as necessary. (b) Check for coolant in the engine oil. Inspect for white steam emitting from exhaust system. Repair as necessary.</p> <p>7. Check water pump and replace as necessary. Refer to Water Pumps in this group.</p> <p>8. Refer to Engine Accessory Drive Belts in this group. Check and correct as necessary.</p> <p>9. Locate leak and repair as necessary.</p>

DIAGNOSIS AND TESTING (Continued)

CONDITION	POSSIBLE CAUSES	CORRECTION
PRESSURE CAP IS BLOWING OFF STEAM AND/OR COOLANT TO COOLANT TANK. TEMPERATURE GAUGE READING MAY BE ABOVE NORMAL BUT NOT HIGH. COOLANT LEVEL MAY BE HIGH IN COOLANT RESERVE/OVERFLOW TANK	1. Pressure relief valve in radiator cap is defective.	1. Check condition of radiator cap and cap seals. Refer to Radiator Caps in this group. Replace cap as necessary.
COOLANT LOSS TO THE GROUND WITHOUT PRESSURE CAP BLOWOFF. GAUGE IS READING HIGH OR HOT	1. Coolant leaks in radiator, cooling system hoses, water pump or engine.	1. Pressure test and repair as necessary. Refer to Testing Cooling System for Leaks in this group.
DETONATION OR PRE-IGNITION (NOT CAUSED BY IGNITION SYSTEM). GAUGE MAY OR MAY NOT BE READING HIGH	1. Engine overheating. 2. Freeze point of antifreeze not correct. Mixture is too rich or too lean.	1. Check reason for overheating and repair as necessary. 2. Check antifreeze. Refer to the Coolant section of this group. Adjust antifreeze-to-water ratio as required.
HOSE OR HOSES COLLAPSED WHEN ENGINE IS COOLING	1. Vacuum created in cooling system on engine cool-down is not being relieved through coolant reserve/overflow system.	1. (a) Radiator cap relief valve stuck. Refer to Radiator Cap in this group. Replace if necessary. (b) Hose between coolant reserve/overflow tank and radiator is kinked. Repair as necessary. (c) Vent at coolant reserve/overflow tank is plugged. Clean vent and repair as necessary. (d) Reserve/overflow tank is internally blocked or plugged. Check for blockage and repair as necessary.
NOISY FAN	1. Fan blades loose. 2. Fan blades striking a surrounding object. 3. Air obstructions at radiator or air conditioning condenser. 4. Thermal viscous fan drive has defective bearing. 5. A certain amount of fan noise (roaring) may be evident from the thermal viscous fan drive. Some of this noise is normal.	1. Replace fan blade assembly. Refer to Cooling System Fans in this group. 2. Locate point of fan blade contact and repair as necessary. 3. Remove obstructions and/or clean debris or insects from radiator or A/C condenser. 4. Replace fan drive. Bearing is not serviceable. Refer to Viscous Fan Drive in this group. 5. Refer to Viscous Fan Drive in this group for an explanation of normal fan noise.

DIAGNOSIS AND TESTING (Continued)

CONDITION	POSSIBLE CAUSES	CORRECTION
INADEQUATE AIR CONDITIONER PERFORMANCE (COOLING SYSTEM SUSPECTED)	<ol style="list-style-type: none"> 1. Radiator and/or A/C condenser is restricted, obstructed or dirty (insects, leaves etc.) 2. Thermal viscous fan drive is free-wheeling. 3. Engine is overheating (heat may be transferred from radiator to A/C condenser. High underhood temperatures due to engine overheating may also transfer heat to A/C components). 4. Some models with certain engines are equipped with air seals at the radiator and/or A/C condenser. If these seals are missing or damaged, not enough air flow will be pulled through the radiator and A/C condenser. 	<ol style="list-style-type: none"> 1. Remove restriction and/or clean as necessary. Refer to Radiator Cleaning in this group. 2. Refer to Viscous Fan Drive for diagnosis. Repair as necessary. 3. Correct overheating condition. Refer to text in Group 7, Cooling. 4. Check for missing or damaged air seals and repair as necessary.
INADEQUATE HEATER PERFORMANCE. THERMOSTAT FAILED IN OPEN POSITION	<ol style="list-style-type: none"> 1. Has a diagnostic trouble code (DTC) been set? 2. Coolant level low. 3. Obstructions in heater hose fittings at engine. 4. Heater hose kinked. 5. Water pump is not pumping water to heater core. When the engine is fully warmed up, both heater hoses should be hot to the touch. If only one of the hoses is hot, the water pump may not be operating correctly. The accessory drive belt may also be slipping causing poor water pump operation. 	<ol style="list-style-type: none"> 1. Refer to group 25, Emission Control System and replace thermostat if necessary. 2. Refer to Testing Cooling System for Leaks in the manual text. Repair as necessary. 3. Remove heater hoses at both ends and check for obstructions. Repair as necessary. 4. Locate kinked area and repair as necessary. 5. Refer to Water Pumps in this group. Repair as necessary. If a slipping belt is detected, refer to Engine Accessory Drive Belts in this group. Repair as necessary.
HEAT ODOR	<ol style="list-style-type: none"> 1. Various heat shields are used at certain drive line components. One or more of these shields may be missing. 2. Is temperature gauge reading above the normal range? 	<ol style="list-style-type: none"> 1. Locate missing shields and replace or repair as necessary. 2. Refer to the previous Temperature Gauge Reads High in these Diagnosis Charts. Repair as necessary.

DIAGNOSIS AND TESTING (Continued)

CONDITION	POSSIBLE CAUSES	CORRECTION
HEAT ODOR	3. Is cooling fan operating correctly. 4. Has undercoating been applied to any unnecessary component. 5. Engine may be running rich causing the catalytic converter to overheat.	3. Refer to Cooling System Fan in this group for diagnosis. Repair as necessary 4. Clean undercoating as necessary. 5. Refer to the DRB scan tool and the appropriate Powertrain Diagnostic Procedures service manual. Repair as necessary.
POOR DRIVEABILITY (THERMOSTAT POSSIBLY STUCK OPEN). GAUGE MAY BE READING LOW	1. For proper driveability, good vehicle emissions and for preventing build-up of engine oil sludge, the thermostat must be operating properly. Has a diagnostic trouble code (DTC) been set?	1. Refer to group 25, Emission Control System. DTC's may also be checked using the DRB scan tool. Refer to the proper Powertrain Diagnostics Procedures service manual for checking the thermostat using the DRB scan tool. Replace thermostat if necessary.
STEAM IS COMING FROM FRONT OF VEHICLE NEAR GRILL AREA WHEN WEATHER IS WET, ENGINE IS WARMED UP AND RUNNING, AND VEHICLE IS STATIONARY. TEMPERATURE GAUGE IS IN NORMAL RANGE	1. During wet weather, moisture (snow, ice or rain condensation) on the radiator will evaporate when the thermostat opens. This opening allows heated water into the radiator. When the moisture contacts the hot radiator, steam may be emitted. This usually occurs in cold weather with no fan or airflow to blow it away.	1. Occasional steam emitting from this area is normal. No repair is necessary.
COOLANT COLOR	1. Coolant color is not necessarily an indication of adequate corrosion or temperature protection. Do not rely on coolant color for determining condition of coolant.	1. Refer to Coolant in this group for antifreeze tests. Adjust antifreeze-to-water ratio as necessary.
COOLANT LEVEL CHANGES IN COOLANT RESERVE/OVERFLOW TANK. TEMPERATURE GAUGE IS IN NORMAL RANGE	1. Level changes are to be expected as coolant volume fluctuates with engine temperature. If the level in the tank was between the FULL and ADD marks at normal engine operating temperature, the level should return to within that range after operation at elevated temperatures.	1. A normal condition. No repair is necessary.

DIAGNOSIS AND TESTING (Continued)

RADIATOR COOLANT FLOW CHECK

The following procedure will determine if coolant is flowing through the cooling system.

If engine is cold, idle engine until normal operating temperature is reached. Then feel the upper radiator hose. If hose is hot, the thermostat is open and water is circulating through cooling system.

COOLING SYSTEM—TESTING FOR LEAKS

ULTRAVIOLET LIGHT METHOD

All Jeep models have a leak detection additive added to the cooling system before they leave the factory. The additive is highly visible under ultraviolet light (black light). If the factory original coolant has been drained, pour one ounce of additive into the cooling system. The additive is available through the parts department. Place the heater control unit in HEAT position. Start and operate the engine until the radiator upper hose is warm to the touch. Aim the commercially available black light tool at the components to be checked. If leaks are present, the black light will cause the additive to glow a bright green color.

The black light can be used along with a pressure tester to determine if any external leaks exist (Fig. 18).

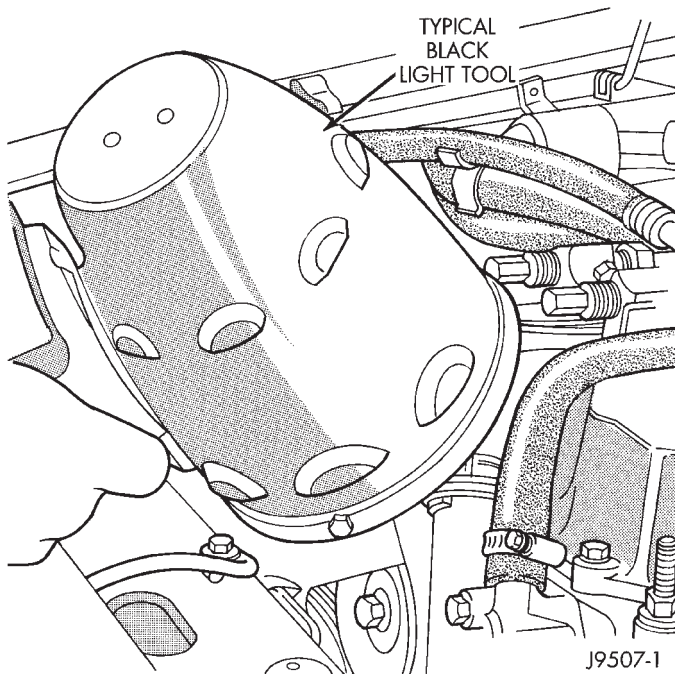


Fig. 18 Leak Detection Using Black Light—Typical PRESSURE TESTER METHOD

The engine should be at the normal operating temperature. Recheck the system cold if the cause of coolant loss is not located during warm engine examination.

WARNING: HOT, PRESSURIZED COOLANT CAN CAUSE INJURY BY SCALDING.

Carefully remove the radiator pressure cap from the filler neck and check the coolant level. Push down on the cap to disengage it from the stop tabs. Wipe the inner part of the filler neck and examine the lower inside sealing seat for nicks, cracks, paint, dirt and solder residue. Inspect the reserve/overflow tank tube for internal obstructions. Insert a wire through the tube to be sure it is not obstructed.

Inspect the cams on the outside part of the filler neck. If the cams are bent, seating of pressure cap valve and tester seal will be affected. Replace cap if cams are bent.

Attach pressure tester 7700 (or an equivalent) to the radiator filler neck (Fig. 19).

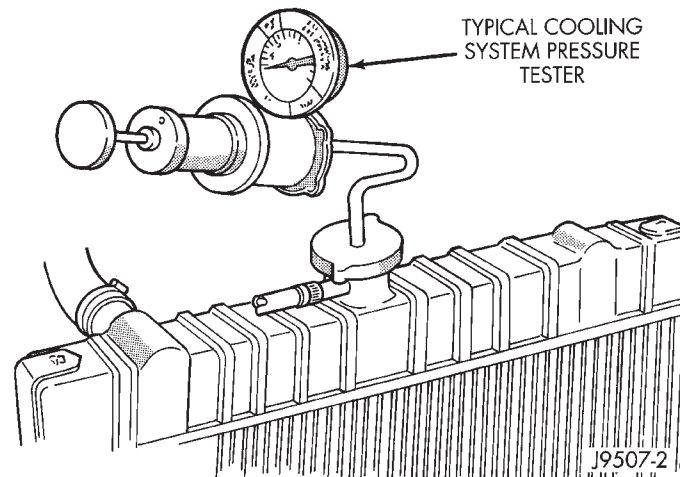


Fig. 19 Pressurizing System—Typical

Operate the tester pump to apply 124 kPa (18 psi) pressure to the system. If the hoses enlarge excessively or bulge while testing, replace as necessary. Observe the gauge pointer and determine the condition of the cooling system according to the following criteria:

- **Holds Steady:** If the pointer remains steady for two minutes, there are no serious coolant leaks in the system. However, there could be an internal leak that does not appear with normal system test pressure. Inspect for interior leakage or do the Internal Leakage Test. Do this if it is certain that coolant is being lost and no leaks can be detected.
- **Drops Slowly:** Shows a small leak or seepage is occurring. Examine all connections for seepage or slight leakage with a flashlight. Inspect the radiator, hoses, gasket edges and heater. Seal any small leak holes with a Sealer Lubricant or equivalent. Repair leak holes and reinspect the system with pressure applied.

DIAGNOSIS AND TESTING (Continued)

- **Drops Quickly:** Shows that a serious leakage is occurring. Examine the system for serious external leakage. If no leaks are visible, inspect for internal leakage. Large radiator leak holes should be repaired by a reputable radiator repair shop.

INTERNAL LEAKAGE INSPECTION

Remove the oil pan drain plug and drain a small amount of engine oil. Coolant, being heavier, will drain first, or operate engine to churn oil, then examine dipstick for water globules. Inspect the transmission dipstick for water globules. Inspect the transmission fluid cooler for leakage. Operate the engine without the pressure cap on the radiator until thermostat opens.

Attach a Pressure Tester to the filler neck. If pressure builds up quickly, a leak exists as result of a faulty cylinder head gasket or crack in the engine. Repair as necessary.

WARNING: DO NOT ALLOW PRESSURE TO EXCEED 124 KPA (18 PSI). TURN THE ENGINE OFF. TO RELEASE THE PRESSURE, ROCK THE TESTER FROM SIDE TO SIDE. WHEN REMOVING THE TESTER, DO NOT TURN THE TESTER MORE THAN 1/2 TURN IF THE SYSTEM IS UNDER PRESSURE.

If there is no immediate pressure increase, pump the Pressure Tester until the indicated pressure is within the system range. Vibration of the gauge pointer indicates compression or combustion leakage into the cooling system.

WARNING: DO NOT DISCONNECT THE SPARK PLUG WIRES WHILE THE ENGINE IS OPERATING.

CAUTION: Do not operate the engine with a spark plug shorted for more than a minute. The catalytic converter may be damaged.

Isolate the compression leak by shorting each spark plug to the cylinder block. The gauge pointer should stop or decrease vibration when spark plug for leaking cylinder is shorted. This happens because of the absence of combustion pressure.

COMBUSTION LEAKAGE TEST (WITHOUT PRESSURE TESTER)

DO NOT WASTE reusable coolant. If the solution is clean, drain the coolant into a clean container for reuse.

WARNING: DO NOT REMOVE THE CYLINDER BLOCK DRAIN PLUGS OR LOOSEN THE RADIATOR DRAINCOCK WITH THE SYSTEM HOT AND UNDER PRESSURE. SERIOUS BURNS FROM COOLANT CAN OCCUR.

Drain sufficient coolant to allow for thermostat removal. Refer to Thermostat Replacement. Disconnect the water pump drive belt.

Disconnect the upper radiator hose from the thermostat housing. Remove the housing and thermostat. Install the thermostat housing.

Add coolant to the radiator to bring the level to within 6.3 mm (1/4 in) of the top of the thermostat housing.

CAUTION: Avoid overheating. Do not operate the engine for an excessive period of time. Open the draincock immediately after the test to eliminate boil over of coolant.

Start the engine and accelerate rapidly three times (to approximately 3000 rpm) while observing the coolant. If internal engine combustion gases are leaking into the cooling system, bubbles will appear in the coolant. If bubbles do not appear, there is no internal combustion gas leakage.

VISCOUS FAN DRIVE**TESTING**

If the fan assembly free-wheels without drag (the fan blades will revolve more than five turns when spun by hand), replace the fan drive. This spin test must be performed when the engine is cool.

For the following test, the cooling system must be in good condition. It also will ensure against excessively high coolant temperature.

WARNING: BE SURE THAT THERE IS ADEQUATE FAN BLADE CLEARANCE BEFORE DRILLING.

(1) Drill a 3.18-mm (1/8-in) diameter hole in the top center of the fan shroud.

(2) Obtain a dial thermometer with an 8 inch stem (or equivalent). It should have a range of -18° to 105°C (0° to 220° F). Insert thermometer through the hole in the shroud. Be sure that there is adequate clearance from the fan blades.

(3) Connect a tachometer and an engine ignition timing light (timing light is to be used as a strobe light).

(4) Block the air flow through the radiator. Secure a sheet of plastic in front of the radiator (or air conditioner condenser). Use tape at the top to secure the plastic and be sure that the air flow is blocked.

(5) Be sure that the air conditioner (if equipped) is turned off.

DIAGNOSIS AND TESTING (Continued)

WARNING: USE EXTREME CAUTION WHEN THE ENGINE IS OPERATING. DO NOT STAND IN A DIRECT LINE WITH THE FAN. DO NOT PUT YOUR HANDS NEAR THE PULLEYS, BELTS OR FAN. DO NOT WEAR LOOSE CLOTHING.

(6) Start the engine and operate at 2400 rpm. Within ten minutes the air temperature (indicated on the dial thermometer) should be up to 88° C (190° F). Fan drive **engagement** should have started to occur at between 74° to 82° C (165° to 180° F). Engagement is distinguishable by a definite **increase** in fan flow noise (roaring). The timing light also will indicate an increase in the speed of the fan.

(7) When the air temperature reaches 88° C (190° F), remove the plastic sheet. Fan drive **disengagement** should have started to occur at between 57° to 79° C (135° to 175° F). A definite **decrease** of fan flow noise (roaring) should be noticed. If not, replace the defective viscous fan drive unit.

RADIATOR CAP TO FILLER NECK SEAL— PRESSURE RELIEF CHECK

With radiator cap installed on filler neck, remove coolant reserve/overflow tank hose from nipple on filler neck. Connect a hand operated vacuum pump to nipple. Operate pump until a reading of 47 to 61 kPa (14 to 18 in. Hg) appears on gauge. If the reading stays steady, or drops slightly and then remains steady, the pressure valve seal is good. Replace radiator cap if reading does not hold.

WARNING: THE WARNING WORDS —DO NOT OPEN HOT— ON THE RADIATOR PRESSURE CAP ARE A SAFETY PRECAUTION. WHEN HOT, PRESSURE BUILDS UP IN COOLING SYSTEM. TO PREVENT SCALDING OR INJURY, THE RADIATOR CAP SHOULD NOT BE REMOVED WHILE THE SYSTEM IS HOT AND/OR UNDER PRESSURE.

There is no need to remove the radiator cap **except** for the following purposes:

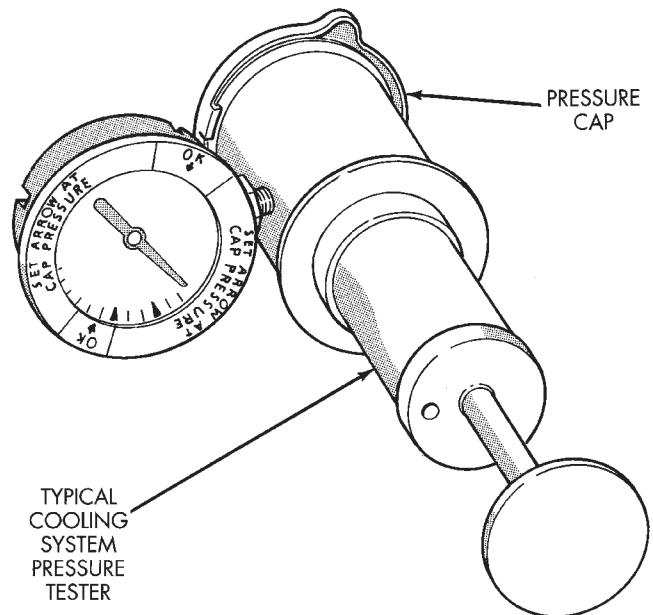
- To check and adjust antifreeze freeze point.
- To refill system with new antifreeze.
- For conducting service procedures.
- When checking for vacuum leaks.

WARNING: IF VEHICLE HAS BEEN RUN RECENTLY, WAIT AT LEAST 15 MINUTES BEFORE REMOVING RADIATOR CAP. WITH A RAG, SQUEEZE RADIATOR UPPER HOSE TO CHECK IF SYSTEM IS UNDER PRESSURE. PLACE A RAG OVER THE CAP AND WITHOUT PUSHING DOWN, ROTATE CAP COUNTER-CLOCKWISE TO THE FIRST STOP. ALLOW FLUID TO ESCAPE THROUGH OVERFLOW HOSE INTO COOLANT RESERVE/OVERFLOW TANK. SQUEEZE RADIATOR UPPER

HOSE TO DETERMINE WHEN PRESSURE HAS BEEN RELEASED. WHEN COOLANT AND STEAM STOP BEING PUSHED INTO TANK AND SYSTEM PRESSURE DROPS, REMOVE RADIATOR CAP COMPLETELY.

RADIATOR CAP—PRESSURE TESTING

Remove cap from radiator. Be sure that sealing surfaces are clean. Moisten rubber gasket with water and install the cap on pressure tester (tool 7700 or an equivalent) (Fig. 20).



J9507-3

Fig. 20 Pressure Testing Radiator Pressure Cap—Typical

Operate the tester pump and observe the gauge pointer at its highest point. The cap release pressure should be 97 to 124 kPa (14 to 18 psi). The cap is satisfactory when the pressure holds steady. It is also good if it holds pressure within the 97 to 124 kPa (14 to 18 psi) range for 30 seconds or more. If the pointer drops quickly, replace the cap.

CAUTION: Radiator pressure testing tools are very sensitive to small air leaks, which will not cause cooling system problems. A pressure cap that does not have a history of coolant loss should not be replaced just because it leaks slowly when tested with this tool. Add water to tool. Turn tool upside down and recheck pressure cap to confirm that cap needs replacement.

DIAGNOSIS AND TESTING (Continued)

LOW COOLANT LEVEL-AERATION

If the coolant level in radiator drops below top of radiator core tubes, air will enter cooling system.

Low coolant level can cause thermostat pellet to be suspended in air instead of coolant. This will cause thermostat to open later, which in turn causes higher coolant temperature. Air trapped in cooling system also reduces amount of coolant circulating in heater core resulting in low heat output.

DEAERATION

As the engine operates, any air trapped in cooling system gathers under the radiator cap. The next time the engine is operated, thermal expansion of coolant will push any trapped air past radiator cap into the coolant reserve/overflow tank. Here it escapes to the atmosphere into the tank. When the engine cools down the coolant, it will be drawn from the reserve/overflow tank into the radiator to replace any removed air.

SERVICE PROCEDURES

COOLANT LEVEL—ROUTINE CHECK

NOTE: Do not remove radiator cap for routine coolant level inspections. The coolant level can be checked at coolant reserve/overflow tank.

The coolant reserve/overflow system provides a quick visual method for determining coolant level without removing radiator pressure cap. With engine idling and at normal operating temperature, observe coolant level in reserve/overflow tank. The coolant level should be between ADD and FULL marks.

COOLANT—ADDING ADDITIONAL

Do not remove radiator cap to add coolant to system. When adding coolant to maintain correct level, do so at coolant reserve/overflow tank. Use a 50/50 mixture of ethylene-glycol antifreeze and low mineral content water. Remove radiator cap only for testing or when refilling system after service. Removing cap unnecessarily can cause loss of coolant and allow air to enter system, which produces corrosion.

SERVICE COOLANT LEVEL

The cooling system is closed and designed to maintain coolant level to top of radiator.

WARNING: DO NOT OPEN RADIATOR DRAINCOCK WITH ENGINE RUNNING OR WHILE ENGINE IS HOT AND COOLING SYSTEM IS UNDER PRESSURE.

When vehicle servicing requires a coolant level check in radiator, drain several ounces of coolant from radiator drain cock. Do this while observing coolant reserve/overflow system tank. The coolant level in reserve/overflow tank should drop slightly. If not, inspect for a leak between radiator and coolant reserve/overflow system connection. Remove radiator cap. The coolant level should be to top of radiator. If not and if coolant level in reserve/overflow tank is at ADD mark, check for:

- An air leak in coolant reserve/overflow tank or its hose
- An air leak in radiator filler neck
- Leak in pressure cap seal to radiator filler neck

COOLING SYSTEM—DRAINING AND FILLING

DRAINING COOLING SYSTEM

WARNING: DO NOT REMOVE THE CYLINDER BLOCK DRAIN PLUGS OR LOOSEN THE RADIATOR DRAINCOCK WITH SYSTEM HOT AND UNDER PRESSURE. SERIOUS BURNS FROM COOLANT CAN OCCUR.

DO NOT WASTE reusable coolant. If the solution is clean, drain the coolant into a clean container for reuse.

DRAINING ENTIRE SYSTEM

Use this procedure if the entire cooling system is to be drained, such as for engine removal.

(1) DO NOT remove radiator cap first. With engine cold, raise vehicle on a hoist and locate radiator draincock.

- 4.0L 6-cyl. Engine: Radiator draincock is located on the right/lower side of radiator facing to rear of vehicle.
- 5.2/5.9L V-8 Engines: Radiator draincock is located on the left/lower side of radiator facing to rear of vehicle.

(2) Attach one end of a hose to the draincock. Put the other end into a clean container. Open draincock and drain coolant from radiator. This will empty the coolant reserve/overflow tank. The coolant does not have to be removed from the tank unless the system is being refilled with a fresh mixture. When tank is empty, remove radiator cap and continue draining cooling system.

SERVICE PROCEDURES (Continued)

To drain the 4.0L 6-cylinder engine of coolant, remove the cylinder block drain plug located on the side of cylinder block (Fig. 21).

To drain the 5.2/5.9L V-8 engines of coolant, remove the cylinder block drain plugs located on the sides of cylinder block above the oil pan rail (Fig. 22).

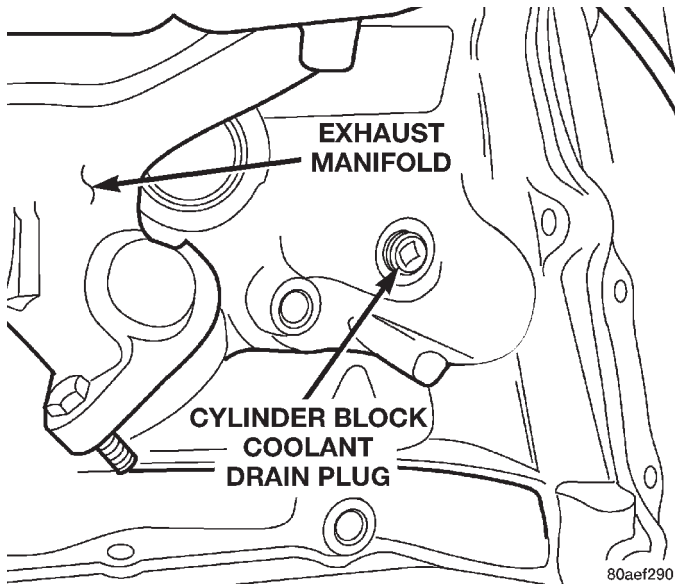


Fig. 21 Cylinder Block Drain Plug—4.0L Engine

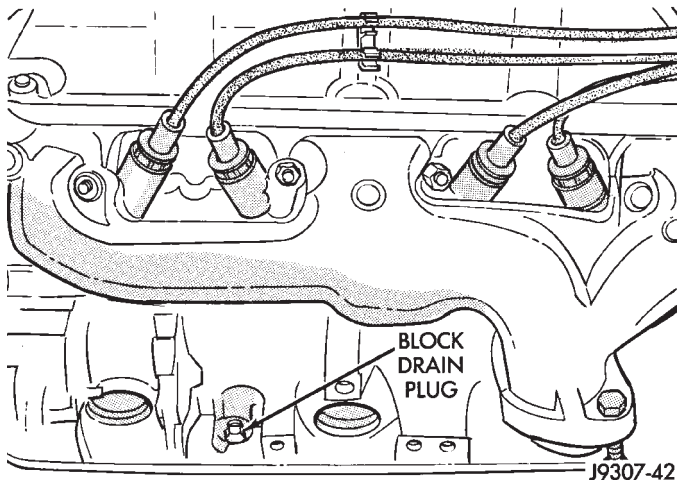
PARTIAL DRAINING

Fig. 22 Cylinder Block Drain Plugs—5.2/5.9L V-8 Engines

Use this procedure if the coolant is to be partially drained, such as for engine thermostat removal.

(1) With engine cold, slowly remove the radiator cap. Raise vehicle on a hoist and locate radiator draincock.

- 4.0L Engine: Radiator draincock is located on the right/lower side of radiator facing to rear of vehicle.

- 5.2/5.9L Engines: Radiator draincock is located on the left/lower side of radiator facing to rear of vehicle.

(2) Attach one end of a hose to the draincock. Put the other end into a clean container.

(3) Open draincock and drain desired amount of coolant from radiator.

REFILLING COOLING SYSTEM

(1) Tighten the radiator draincock and the cylinder block drain plug(s) (if removed).

(2) Fill system using a 50/50 mixture of ethylene-glycol antifreeze and low mineral content water. Fill radiator to top and install radiator cap. Add sufficient coolant to the reserve/overflow tank to raise level to FULL mark.

(3) With heater control unit in the HEAT position, operate engine with radiator cap in place.

(4) After engine has reached normal operating temperature, shut engine off and allow it to cool. When engine is cooling down, coolant will be drawn into the radiator from the reserve/overflow tank.

(5) Add coolant to reserve/overflow tank as necessary. **Only add coolant to the reserve/overflow tank when the engine is cold. Coolant level in a warm engine will be higher due to thermal expansion.** To purge the cooling system of all air, this heat up/cool down cycle (adding coolant to cold engine) must be performed three times. Add necessary coolant to raise tank level to the FULL mark after each cool down period.

COOLING SYSTEM—REVERSE FLUSHING

CAUTION: The cooling system normally operates at 97 to 124 kPa (14 to 18 psi) pressure. Exceeding this pressure may damage the radiator or hoses.

CHEMICAL CLEANING

In some instances, use a radiator cleaner (Mopar Radiator Kleen or equivalent) before flushing. This will soften scale and other deposits and aid the flushing operation.

CAUTION: Be sure instructions on the container are followed.

REVERSE FLUSHING

Reverse flushing of the cooling system is the forcing of water through the cooling system. This is done using air pressure in the opposite direction of normal coolant flow. It is usually only necessary with very dirty systems with evidence of partial plugging.

SERVICE PROCEDURES (Continued)

REVERSE FLUSHING RADIATOR

Disconnect the radiator hoses from the radiator fittings. Attach a section of radiator hose to the radiator bottom outlet fitting and insert the flushing gun. Connect a water supply hose and air supply hose to the flushing gun.

CAUTION: The cooling system normally operates at 97 to 124 kPa (14 to 18 psi) pressure. Exceeding this pressure may damage the radiator or hoses.

Allow the radiator to fill with water. When radiator is filled, apply air in short blasts allowing radiator to refill between blasts. Continue this reverse flushing until clean water flows out through rear of radiator cooling tube passages. For more information, refer to operating instructions supplied with flushing equipment. Have radiator cleaned more extensively by a radiator repair shop.

REVERSE FLUSHING ENGINE

Drain the cooling system. Remove the thermostat housing and thermostat. Install the thermostat housing. Disconnect the radiator upper hose from the radiator and attach the flushing gun to the hose. Disconnect the radiator lower hose from the water pump. Attach a lead away hose to the water pump inlet fitting.

Connect the water supply hose and air supply hose to the flushing gun. Allow the engine to fill with water. When the engine is filled, apply air in short blasts, allowing the system to fill between air blasts. Continue until clean water flows through the lead away hose. For more information, refer to operating instructions supplied with flushing equipment.

Remove the lead away hose, flushing gun, water supply hose and air supply hose. Remove the thermostat housing and install thermostat. Install the thermostat housing with a replacement gasket. Refer to Thermostat Replacement. Connect the radiator hoses. Refill the cooling system with the correct anti-freeze/water mixture.

REMOVAL AND INSTALLATION

AUTOMATIC TRANSMISSION OIL COOLER

The internal transmission oil cooler located within the radiator is not serviceable. If it requires service, the radiator must be replaced.

Once the repaired or replacement radiator has been installed, fill the cooling system and inspect for leaks. Refer to the Filling Cooling System and Testing Cooling System For Leaks sections in this group. If the transmission operates properly after repairing the leak, drain the transmission and remove the transmission oil pan. Inspect for sludge. Inspect for a

dirty or plugged inlet filter. If none of these conditions are found, the transmission and torque converter may require reconditioning. Refer to Group 21 for automatic transmission servicing.

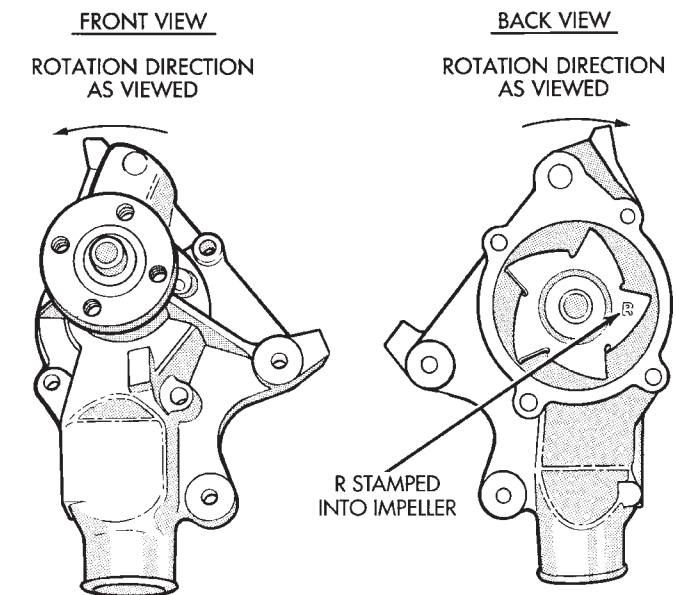
WATER PUMP—4.0L ENGINE

CAUTION: If the water pump is replaced because of mechanical damage, the fan blades and viscous fan drive should also be inspected. These components could have been damaged due to excessive vibration.

REMOVAL

The water pump can be removed without discharging the air conditioning system (if equipped).

CAUTION: The 4.0L engine has a reverse (counterclockwise) rotating water pump. The letter R is stamped into the back of the water pump impeller (Fig. 23) to identify. Engines from previous model years, depending upon application, may be equipped with a forward (clockwise) rotating water pump. Installation of the wrong water pump will cause engine over heating.



J9307-10

Fig. 23 Reverse Rotating Water Pump—Typical

The water pump impeller is pressed on the rear of the pump shaft and bearing assembly. The water pump is serviced only as a complete assembly.

WARNING: DO NOT REMOVE THE BLOCK DRAIN PLUG(S) OR LOOSEN RADIATOR DRAINCOCK WITH THE SYSTEM HOT AND UNDER PRESSURE. SERIOUS BURNS FROM COOLANT CAN OCCUR.

REMOVAL AND INSTALLATION (Continued)

DO NOT WASTE reusable coolant. If the solution is clean, drain coolant into a clean container for reuse.

- (1) Disconnect negative battery cable at battery.
- (2) Drain the cooling system.
- (3) **Vehicles with 4.0L 6-cylinder engine equipped with A/C or heavy duty cooling system:**
- (4) Loosen (but do not remove at this time) the four water pump pulley-to-water pump hub mounting bolts (Fig. 24).

(5) **Vehicles with 4.0L 6-cylinder engine without A/C or heavy duty cooling system:**

- (6) Loosen (but do not remove at this time) the four fan hub-to-water pump pulley mounting nuts (Fig. 25).

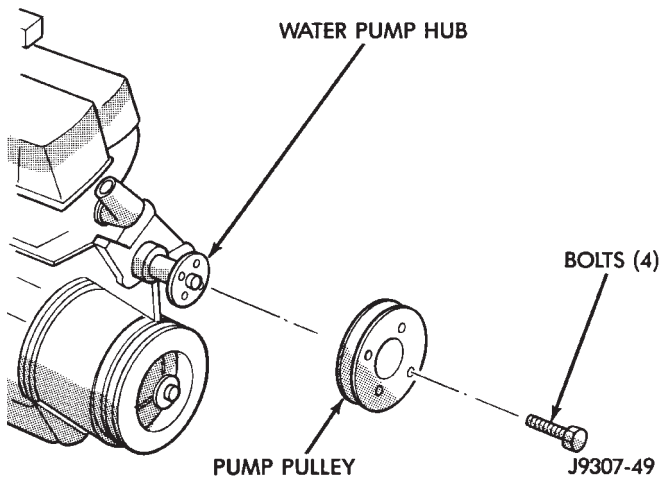


Fig. 24 Water Pump Pulley Bolts

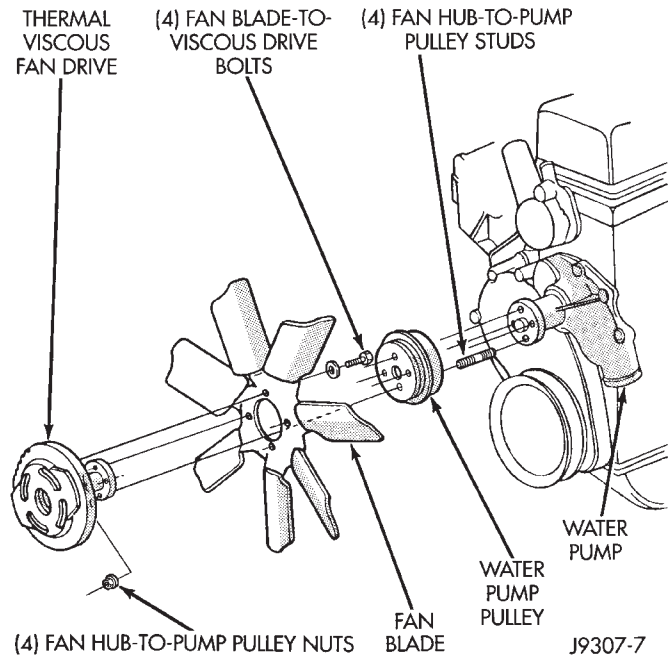


Fig. 25 Fan Mounting Nuts

NOTE: The engine accessory drive belt must be removed prior to removing the fan (if installed at pump) or fan pulley.

- (7) Remove engine drive belt.
- (8) Remove power steering pump (Fig. 26), refer to Group 19 Steering.

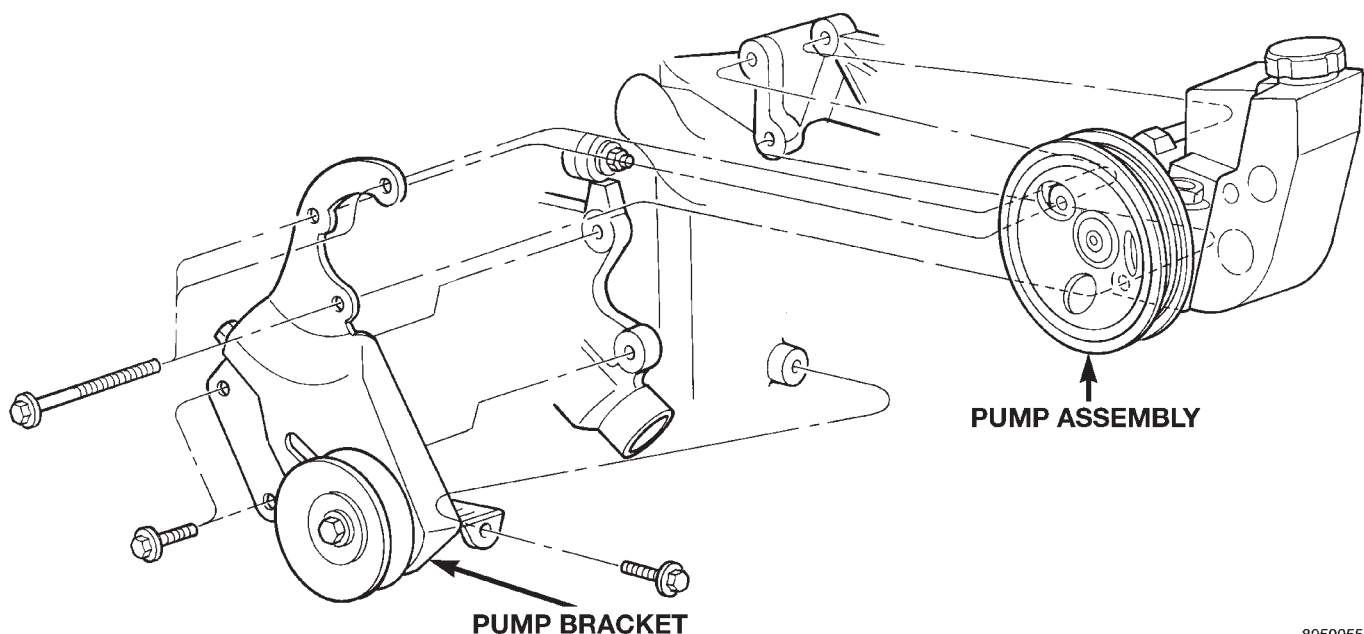
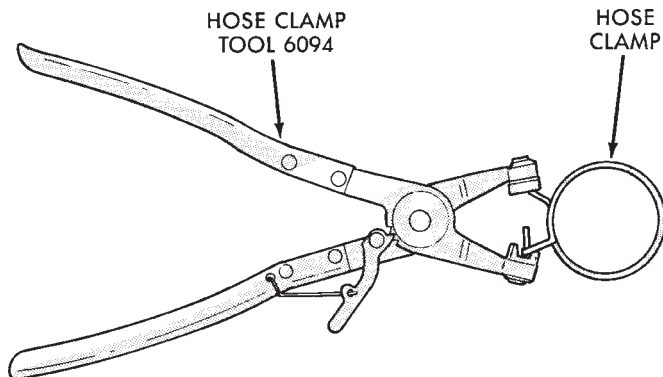


Fig. 26 Power Steering Pump Attachment

REMOVAL AND INSTALLATION (Continued)

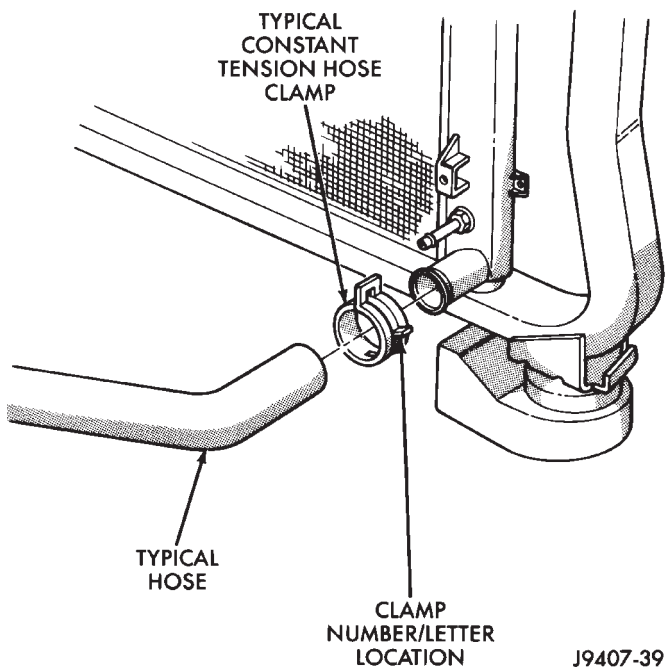
WARNING: CONSTANT TENSION HOSE CLAMPS ARE USED ON MOST COOLING SYSTEM HOSES. WHEN REMOVING OR INSTALLING, USE ONLY TOOLS DESIGNED FOR SERVICING THIS TYPE OF CLAMP, SUCH AS SPECIAL CLAMP TOOL (NUMBER 6094) (Fig. 27) SNAP-ON CLAMP TOOL (NUMBER HPC-20) MAY BE USED FOR LARGER CLAMPS. ALWAYS WEAR SAFETY GLASSES WHEN SERVICING CONSTANT TENSION CLAMPS.



J9207-36

Fig. 27 Hose Clamp Tool—Typical

CAUTION: A number or letter is stamped into the tongue of constant tension clamps (Fig. 28). If replacement is necessary, use only an original equipment clamp with matching number or letter.



J9407-39

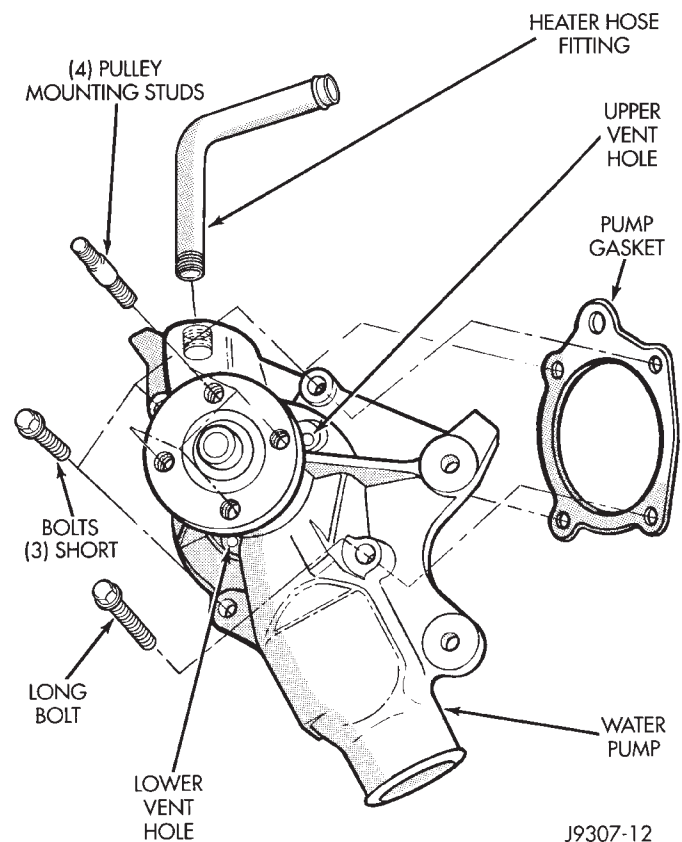
Fig. 28 Clamp Number/Letter Location

(9) Remove lower radiator hose from water pump. Remove heater hose from water pump fitting.

(10) Remove four nuts or bolts previously loosened and remove the fan blade assembly and pulley (if fan is installed at pump), or remove the pulley from the vehicle.

(11) After removing fan blade/viscous fan drive assembly, **do not** place thermal viscous fan drive in horizontal position. If stored horizontally, silicone fluid in viscous fan drive could drain into its bearing assembly and contaminate lubricant.

(12) Remove the four pump mounting bolts (Fig. 29) and remove pump from vehicle. Discard old gasket. Note that one of the four bolts is longer than the other bolts.



J9307-12

Fig. 29 Water Pump Remove/Install—Typical

(13) If pump is to be replaced, the heater hose fitting must be removed. Note position of fitting before removal.

INSTALLATION

(1) If pump is being replaced, install the heater hose fitting to the pump. Use a sealant on the fitting such as Mopar™ Thread Sealant With Teflon. Refer to the directions on the package.

(2) Clean the gasket mating surfaces. If the original pump is used, remove any deposits or other foreign material. Inspect the cylinder block and water

REMOVAL AND INSTALLATION (Continued)

pump mating surfaces for erosion or damage from cavitation.

(3) Install the gasket and water pump. The silicone bead on the gasket should be facing the water pump. Also, the gasket is installed dry. Tighten mounting bolts to 30 N·m (22 ft. lbs.) torque. Rotate the shaft by hand to be sure it turns freely.

(4) Connect the radiator and heater hoses to the water pump.

(5) Position water pump pulley to water pump hub.

(6) If equipped with a water pump mounted fan, install fan and four nuts to water pump hub. If not equipped with a water pump mounted fan, install four pump hub bolts. Tighten bolts (or nuts) to 27 N·m (20 ft. lbs.) torque.

(7) Install power steering pump.

CAUTION: When installing the serpentine engine accessory drive belt, the belt **MUST** be routed correctly. If not, the engine may overheat due to the water pump rotating in the wrong direction. Refer to the Belt Removal and Installation in this group for appropriate belt routing. You may also refer to the Belt Routing Label in the vehicle engine compartment.

(8) Adjust accessory drive belt, refer to Accessory Drive Belt removal and installation in this group.

(9) Fill cooling system with coolant and check for leaks. Refer to Refilling Cooling System in this group.

(10) Connect battery cable to battery.

(11) Start and warm the engine. Check for leaks.

WATER PUMP—5.2L/5.9L ENGINES

The water pump on 5.2L/5.9L engines is bolted directly to the engine timing chain case/cover.

A gasket is used as a seal between the water pump and timing chain case/cover.

If water pump is replaced because of bearing/shaft damage, or leaking shaft seal, the mechanical cooling fan assembly should also be inspected. Inspect for fatigue cracks, loose blades, or loose rivets that could have resulted from excessive vibration. Replace fan if any of these conditions are found. Also check condition of the thermal viscous fan drive. Refer to Viscous Fan Drive in this group.

The water pump can be removed without discharging the air conditioning system (if equipped).

REMOVAL

(1) Disconnect negative battery cable from battery.

(2) Drain cooling system. Refer to Draining Cooling System in this group.

Do not waste reusable coolant. If solution is clean, drain coolant into a clean container for reuse.

(3) The thermal viscous fan drive is attached (threaded) to the water pump hub shaft (Fig. 30). Remove fan/viscous fan drive assembly from water pump by turning mounting nut counterclockwise as viewed from front. Threads on viscous fan drive are **RIGHT HAND**. A Snap-On 36 MM Fan Wrench (number SP346 from Snap-On Cummins Diesel Tool Set number 2017DSP) can be used. Place a bar or screwdriver between water pump pulley bolts (Fig. 30) to prevent pulley from rotating. Do not attempt to remove fan/viscous fan drive assembly from vehicle at this time.

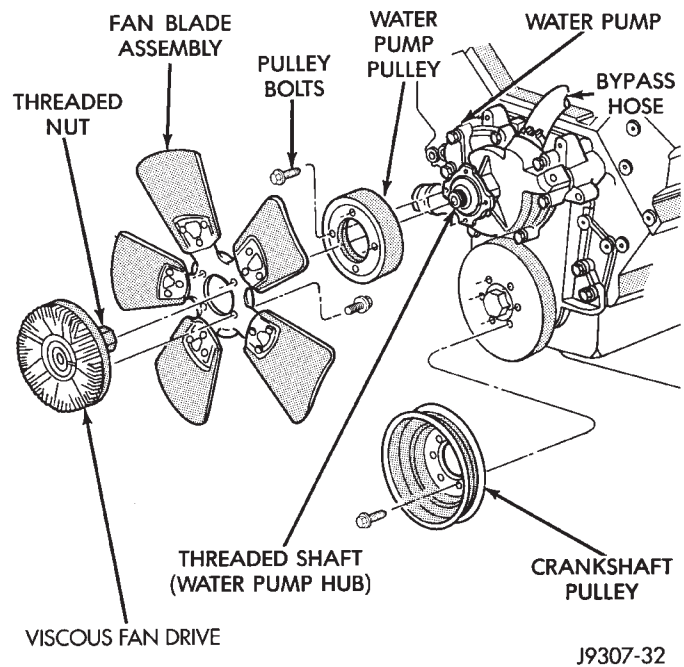


Fig. 30 Fan Blade and Viscous Fan Drive—5.2/5.9L Engines

WARNING: CONSTANT TENSION HOSE CLAMPS ARE USED ON MOST COOLING SYSTEM HOSES. WHEN REMOVING OR INSTALLING, USE ONLY TOOLS DESIGNED FOR SERVICING THIS TYPE OF CLAMP, SUCH AS SPECIAL CLAMP TOOL (NUMBER 6094) (Fig. 27). SNAP-ON CLAMP TOOL (NUMBER HPC-20) MAY BE USED FOR LARGER CLAMPS. ALWAYS WEAR SAFETY GLASSES WHEN SERVICING CONSTANT TENSION CLAMPS.

CAUTION: A number or letter is stamped into the tongue of constant tension clamps (Fig. 28). If replacement is necessary, use only an original equipment clamp with matching number or letter.

(4) If water pump is being replaced, do not unbolt fan blade assembly (Fig. 30) from thermal viscous fan drive.

J9307-32

REMOVAL AND INSTALLATION (Continued)

(5) Remove two fan shroud-to-radiator nuts (Fig. 31). Do not attempt to remove fan shroud at this time.

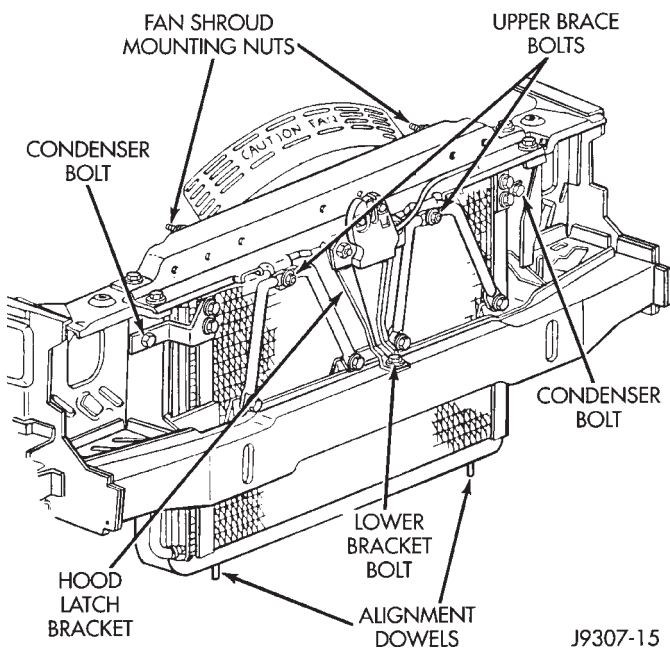


Fig. 31 Fan Shroud Nuts

(6) Remove fan shroud and fan blade/viscous fan drive assembly from vehicle as a complete unit.

(7) After removing fan blade/viscous fan drive assembly, **do not** place thermal viscous fan drive in horizontal position. If stored horizontally, silicone fluid in viscous fan drive could drain into its bearing assembly and contaminate lubricant.

(8) **Do not** remove water pump pulley bolts at this time.

(9) Remove accessory drive belt as follows: The drive belt is equipped with a spring loaded automatic belt tensioner (Fig. 32). Relax tension from belt by rotating tensioner clockwise (as viewed from front) (Fig. 32). When all belt tension has been relaxed, remove accessory drive belt.

(10) Remove four water pump pulley-to-water pump hub bolts (Fig. 30) and remove pulley from vehicle.

(11) Remove lower radiator hose clamp and remove lower hose at water pump.

(12) Remove heater hose clamp (Fig. 33) and heater hose from heater hose coolant return tube.

(13) Loosen heater hose coolant return tube mounting bolt and nut (Fig. 33) and remove tube from water pump. Discard the old tube o-ring.

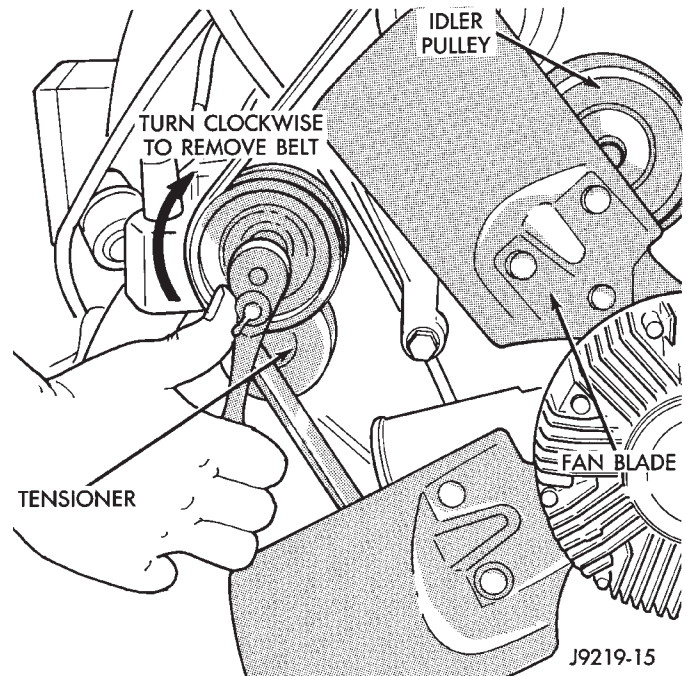


Fig. 32 Belt Tensioner Assembly—5.2L/5.9L Engines

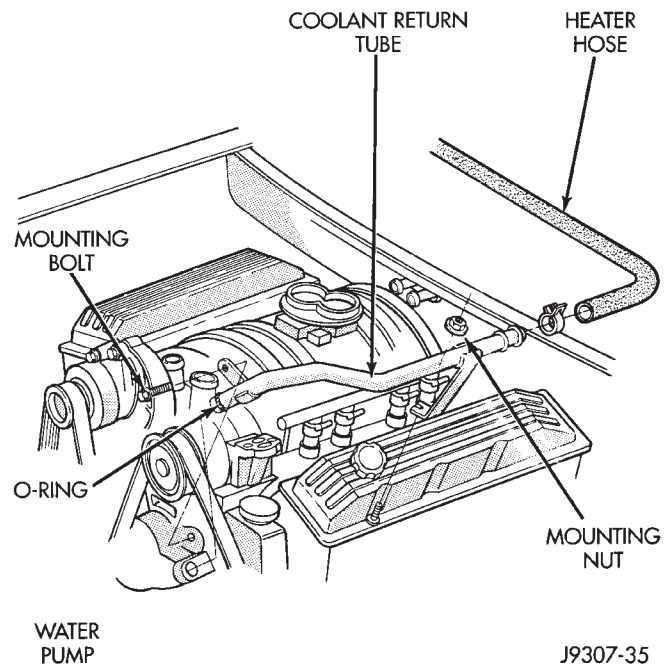


Fig. 33 Coolant Return Tube—5.2L/5.9L Engines

REMOVAL AND INSTALLATION (Continued)

(14) Remove seven water pump mounting bolts (Fig. 34).

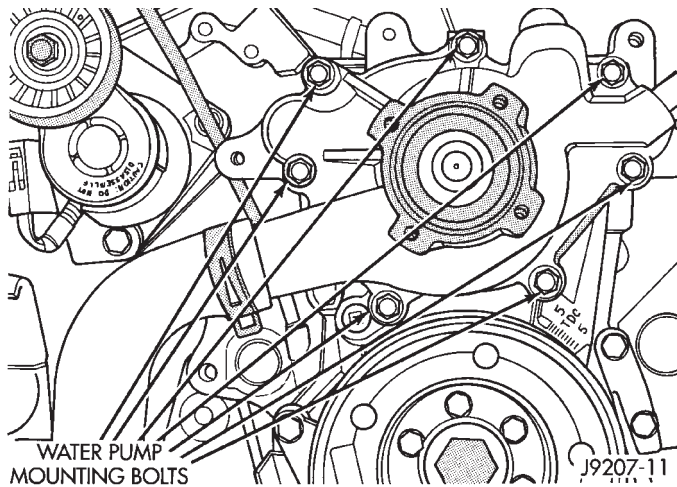


Fig. 34 Water Pump Bolts—5.2L/5.9L Engines—Typical

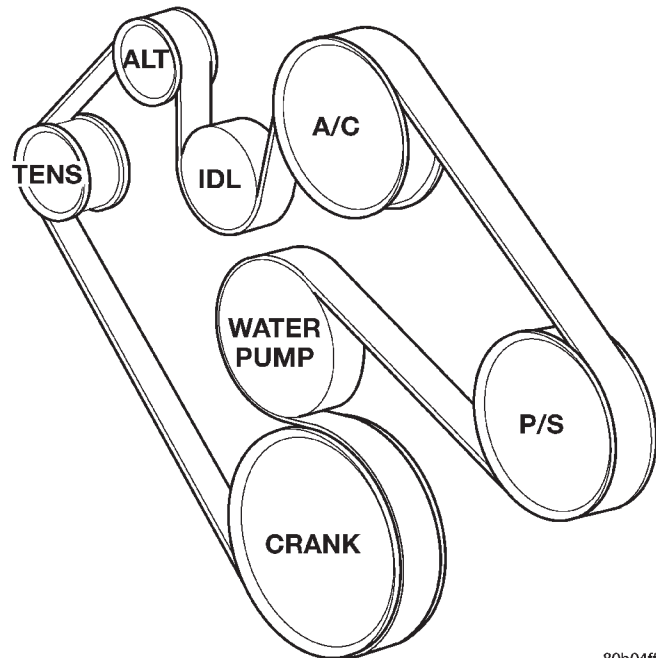
(15) Loosen clamp at water pump end of bypass hose (Fig. 30). Slip bypass hose from water pump while removing pump from vehicle. Discard old gasket.

CAUTION: Do not pry water pump at timing chain case/cover. The machined surfaces may be damaged resulting in leaks.

INSTALLATION

- (1) Clean gasket mating surfaces.
- (2) Using a new gasket, install water pump to engine as follows: Guide water pump nipple into bypass hose as pump is being installed. Install water pump bolts (Fig. 34). Tighten water pump mounting bolts to 40 N·m (30 ft. lbs.) torque.
- (3) Position bypass hose clamp to bypass hose.
- (4) Spin water pump to be sure that pump impeller does not rub against timing chain case/cover.
- (5) Install a new o-ring to the heater hose coolant return tube (Fig. 33). Coat the new o-ring with anti-freeze before installation.
- (6) Install coolant return tube to engine (Fig. 33). Be sure the slot in tube bracket is bottomed to the mounting bolt. This will properly position return tube.
- (7) Connect radiator lower hose to water pump.
- (8) Connect heater hose and hose clamp to coolant return tube.
- (9) Install water pump pulley. Tighten bolts to 27 N·m (20 ft. lbs.) torque. Place a bar or screwdriver between water pump pulley bolts (Fig. 30) to prevent pulley from rotating.
- (10) Relax tension from belt tensioner (Fig. 32). Install drive belt.

CAUTION: When installing the serpentine accessory drive belt, belt must be routed correctly. If not, engine may overheat due to water pump rotating in wrong direction. Refer to (Fig. 35) for correct belt routing. Or, refer to the Belt Routing Label located in the engine compartment. The correct belt with correct length must be used.



80b04ff8

Fig. 35 Belt Routing—5.2L/5.9L Engines

(11) Position fan shroud and fan blade/viscous fan drive assembly to vehicle as a complete unit.

(12) Be sure the upper and lower portions of the fan shroud are firmly connected. All air must flow through the radiator.

(13) Install two fan shroud-to-radiator nuts (Fig. 31).

(14) Be sure of at least 25 mm (1.0 inches) between tips of fan blades and fan shroud.

(15) Install fan blade/viscous fan drive assembly to water pump shaft.

(16) Fill cooling system. Refer to Refilling the Cooling System in this group.

(17) Connect negative battery cable.

(18) Start and warm the engine. Check for leaks.

THERMOSTAT—4.0L ENGINE**REMOVAL**

WARNING: DO NOT LOOSEN THE RADIATOR DRAINCOCK WITH THE SYSTEM HOT AND PRESSURIZED. SERIOUS BURNS FROM THE COOLANT CAN OCCUR.

REMOVAL AND INSTALLATION (Continued)

Do not waste reusable coolant. If the solution is clean, drain the coolant into a clean container for reuse.

(1) Drain the coolant from the radiator until the level is below the thermostat housing.

WARNING: CONSTANT TENSION HOSE CLAMPS ARE USED ON MOST COOLING SYSTEM HOSES. WHEN REMOVING OR INSTALLING, USE ONLY TOOLS DESIGNED FOR SERVICING THIS TYPE OF CLAMP, SUCH AS SPECIAL CLAMP TOOL (NUMBER 6094) (Fig. 51). SNAP-ON CLAMP TOOL (NUMBER HPC-20) MAY BE USED FOR LARGER CLAMPS. ALWAYS WEAR SAFETY GLASSES WHEN SERVICING CONSTANT TENSION CLAMPS.

CAUTION: A number or letter is stamped into the tongue of constant tension clamps (Fig. 52). If replacement is necessary, use only an original equipment clamp with matching number or letter.

(2) Remove radiator upper hose and heater hose at thermostat housing.

(3) Disconnect wiring connector at engine coolant temperature sensor.

(4) Remove thermostat housing mounting bolts, thermostat housing, gasket and thermostat (Fig. 36). Discard old gasket.

(5) Clean the gasket mating surfaces.

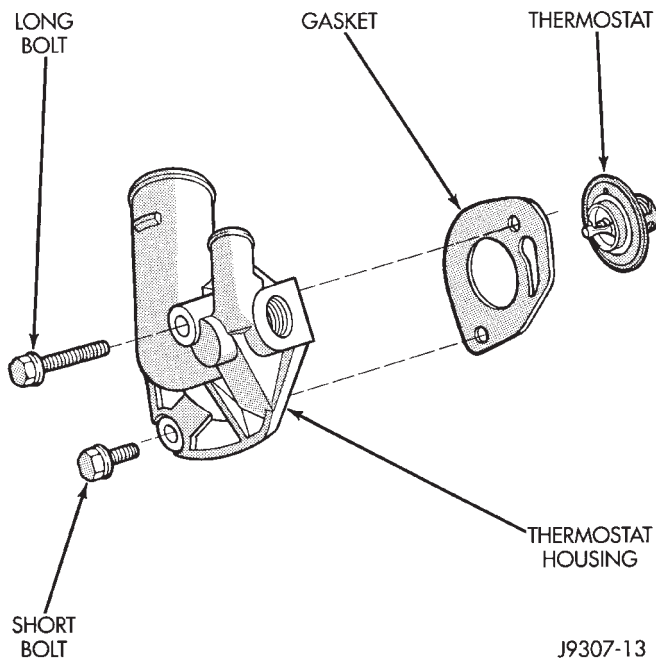


Fig. 36 Thermostat Removal/Installation—4.0L Engine

INSTALLATION

(1) Install the replacement thermostat so that the pellet, which is encircled by a coil spring, faces the engine. All thermostats are marked on the outer flange to indicate the proper installed position.

(a) Observe the recess groove in the engine cylinder head (Fig. 37).

(b) Position thermostat in groove with arrow and air bleed hole on outer flange pointing up.

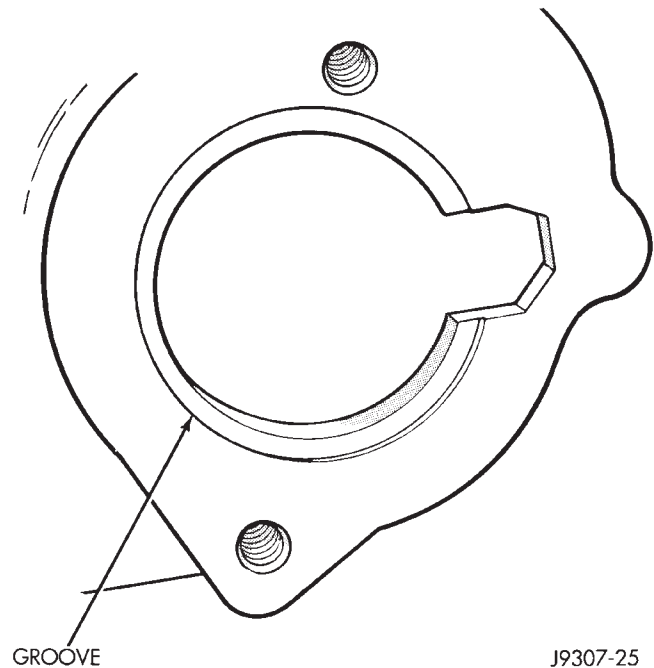


Fig. 37 Thermostat Recess—4.0L Engine

(2) Install replacement gasket and thermostat housing.

CAUTION: Tightening the thermostat housing unevenly or with the thermostat out of its recess, may result in a cracked housing.

(3) Tighten the housing bolts to 22 N·m (16 ft. lbs.) torque.

(4) Install hoses to thermostat housing.

(5) Install electrical connector to coolant temperature sensor.

(6) Be sure that the radiator draincock is tightly closed. Fill the cooling system to the correct level with the required coolant mixture. Refer to Refilling Cooling System in this group.

(7) Start and warm the engine. Check for leaks.

REMOVAL AND INSTALLATION (Continued)**THERMOSTAT—5.2L/5.9L ENGINES****REMOVAL**

**WARNING: DO NOT LOOSEN RADIATOR DRAIN-
COCK WITH SYSTEM HOT AND PRESSURIZED.
SERIOUS BURNS FROM COOLANT CAN OCCUR.**

Do not waste reusable coolant. If solution is clean, drain coolant into a clean container for reuse.

If thermostat is being replaced, be sure that replacement is specified thermostat for vehicle model and engine type.

Factory installed thermostat housings on 5.2/5.9L engines are installed on a gasket with an anti-stick coating. This will aid in gasket removal and clean-up.

- (1) Disconnect negative battery cable at battery.
- (2) Drain cooling system until coolant level is below thermostat. Refer to Draining Cooling System in this group.
- (3) Air Conditioned vehicles: Remove support bracket (generator mounting bracket-to-intake manifold) located near rear of generator (Fig. 38).

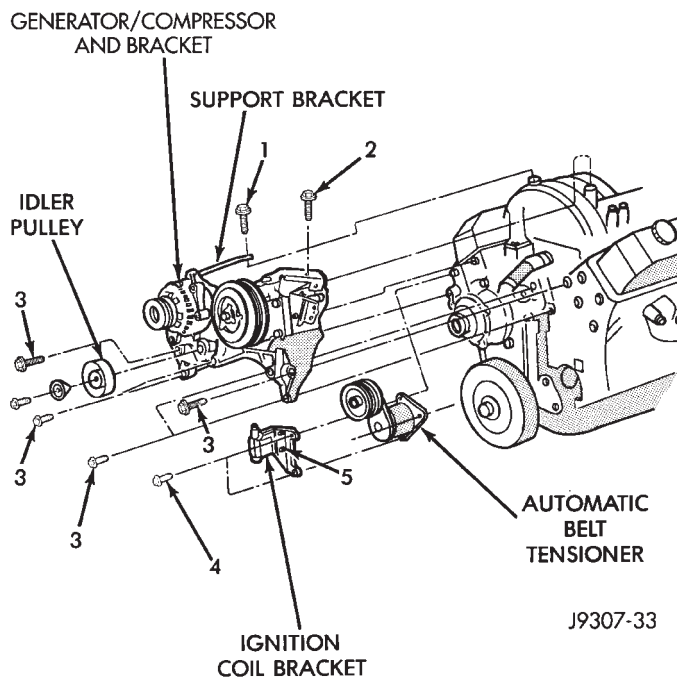


Fig. 38 Generator Support Bracket—5.2L/5.9L Engines

(4) On air conditioning equipped vehicles, the generator must be partially removed.

(a) Remove generator drive belt as follows: Drive belts on the 5.2L/5.9L engines are equipped with a spring loaded automatic belt tensioner (Fig. 39).

(b) Attach a socket/wrench to pulley mounting bolt of automatic belt tensioner (Fig. 39).

(c) Rotate tensioner assembly clockwise (as viewed from front) until tension has been relieved from belt.

(d) Remove belt from vehicle.

(e) Remove two generator mounting bolts. Do not remove any wiring at generator. If equipped with 4WD, unplug 4WD indicator lamp wiring harness (located near rear of generator).

(f) Remove generator. Position generator to gain access for thermostat gasket removal.

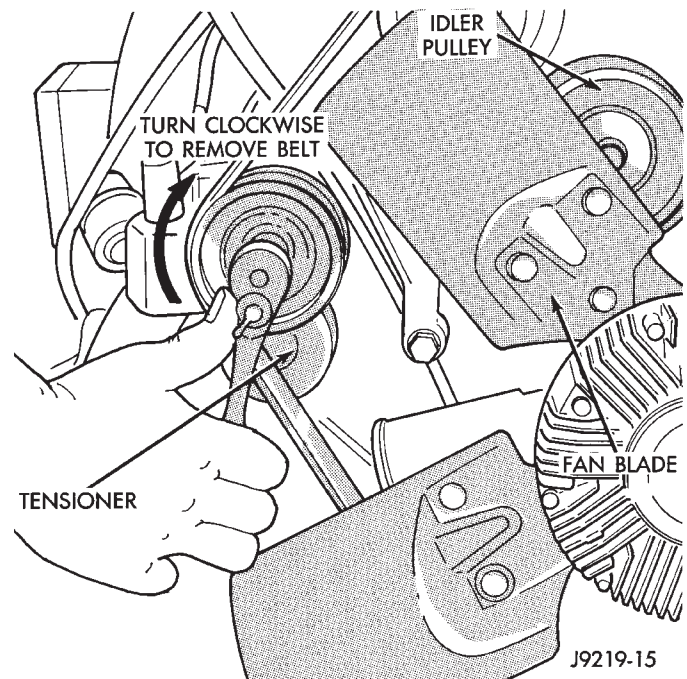


Fig. 39 Automatic Belt Tensioner—5.2L/5.9L Engines

(5) Remove upper radiator hose clamp (Fig. 51) and upper radiator hose at thermostat housing.

(6) Position wiring harness (behind thermostat housing) to gain access to thermostat housing.

(7) Remove thermostat housing mounting bolts, thermostat housing, gasket and thermostat (Fig. 40). Discard old gasket.

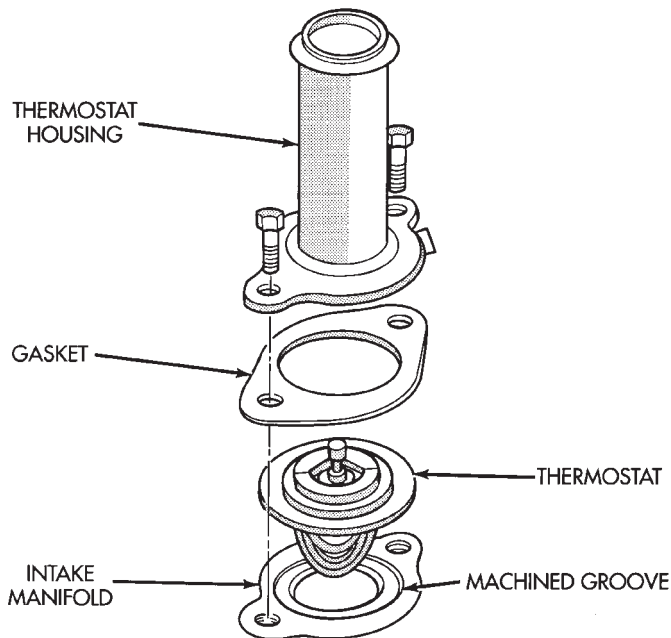
INSTALLATION

(1) Clean mating areas of intake manifold and thermostat housing.

(2) Install thermostat (spring side down) into recessed machined groove on intake manifold (Fig. 40).

(3) Install gasket on intake manifold and over thermostat (Fig. 40).

REMOVAL AND INSTALLATION (Continued)

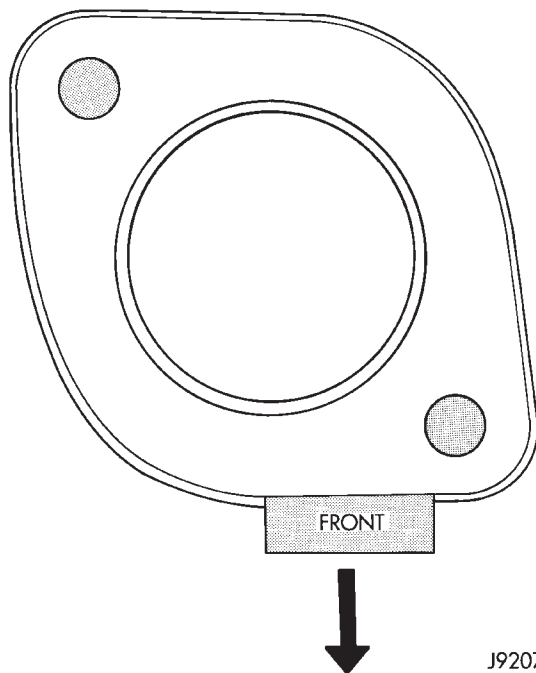


J9207-14

Fig. 40 Thermostat—5.2L/5.9L Engines

(4) Position thermostat housing to intake manifold. Note the word FRONT stamped on housing (Fig. 41). For adequate clearance, this **must** be placed towards front of vehicle. The housing is slightly angled forward after installation to intake manifold.

(5) Install two housing-to-intake manifold bolts. Tighten bolts to 23 N·m (200 in. lbs.) torque.



J9207-13

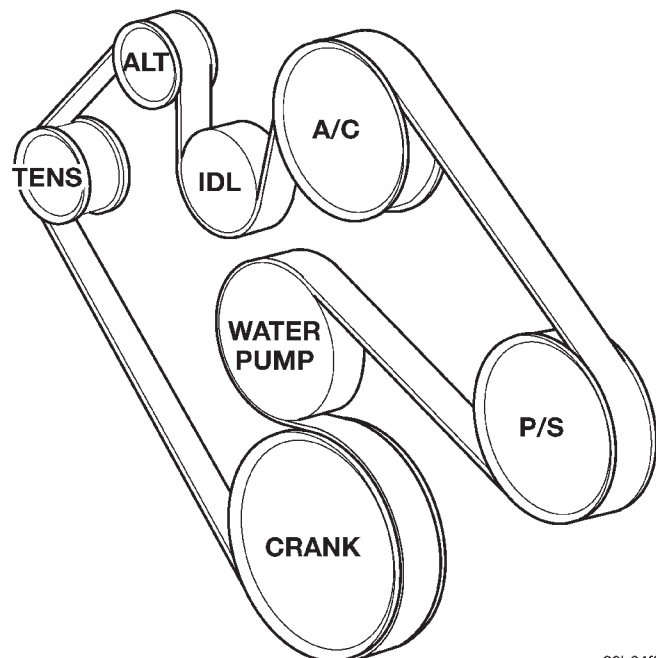
Fig. 41 Thermostat Position—5.2L/5.9L Engines

CAUTION: Housing must be tightened evenly and thermostat must be centered into recessed groove in intake manifold. If not, it may result in a cracked housing, damaged intake manifold threads or coolant leak.

- (6) Install upper radiator hose to thermostat housing.
- (7) Air Conditioned vehicles:

CAUTION: When installing the serpentine accessory drive belt, belt must be routed correctly. If not, engine may overheat due to water pump rotating in wrong direction. Refer to (Fig. 42) for correct 5.2/5.9L engine belt routing. Or, refer to the Belt Routing Label located in the engine compartment. The correct belt with correct length must be used.

- (a) Install generator. Tighten bolts to 41 N·m (30 ft. lbs.) torque.
- (b) Install support bracket (generator mounting bracket-to-intake manifold) (Fig. 38). Tighten bolts to 54 N·m (40 ft. lbs.) torque.
- (c) Position drive belt over all pulleys **except** idler pulley (located between generator and A/C compressor).
- (d) Attach a socket/wrench to pulley mounting bolt of automatic belt tensioner (Fig. 39).
- (e) Rotate socket/wrench clockwise. Place belt over idler pulley. Let tensioner rotate back into place. Remove wrench. Be sure belt is properly seated on all pulleys.
- (8) Fill cooling system. Refer to Refilling Cooling System in this group.



80b04ff8

Fig. 42 Belt Routing—5.2L/5.9L Engines

REMOVAL AND INSTALLATION (Continued)

- (9) Connect negative battery cable to battery.
- (10) Start and warm the engine. Check for leaks.

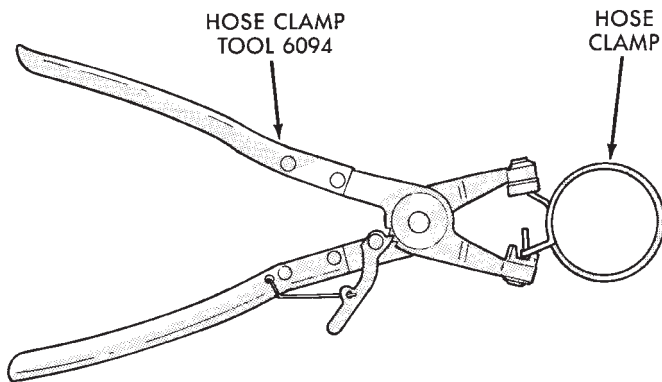
RADIATOR**REMOVAL**

WARNING: DO NOT REMOVE THE CYLINDER BLOCK DRAIN PLUGS OR LOOSEN THE RADIATOR DRAINCOCK WITH THE SYSTEM HOT AND UNDER PRESSURE. SERIOUS BURNS FROM COOLANT CAN OCCUR. REFER TO COOLING SYSTEM DRAINING IN THIS GROUP.

Do not waste reusable coolant. If the solution is clean, drain the coolant into a clean container for reuse.

WARNING: CONSTANT TENSION HOSE CLAMPS ARE USED ON MOST COOLING SYSTEM HOSES. WHEN REMOVING OR INSTALLING, USE ONLY TOOLS DESIGNED FOR SERVICING THIS TYPE OF CLAMP, SUCH AS SPECIAL CLAMP TOOL (NUMBER 6094) (Fig. 43). SNAP-ON CLAMP TOOL (NUMBER HPC-20) MAY BE USED FOR LARGER CLAMPS. ALWAYS WEAR SAFETY GLASSES WHEN SERVICING CONSTANT TENSION CLAMPS.

CAUTION: A number or letter is stamped into the tongue of constant tension clamps (Fig. 44). If replacement is necessary, use only an original equipment clamp with matching number or letter.



J9207-36

Fig. 43 Hose Clamp Tool—Typical

CAUTION: When removing the radiator or A/C condenser for any reason, note the location of all radiator-to-body and radiator-to-A/C condenser rubber air seals (Fig. 45). These are used at the top, bottom and sides of the radiator and A/C condenser. To prevent overheating, these seals must be installed to their original positions.

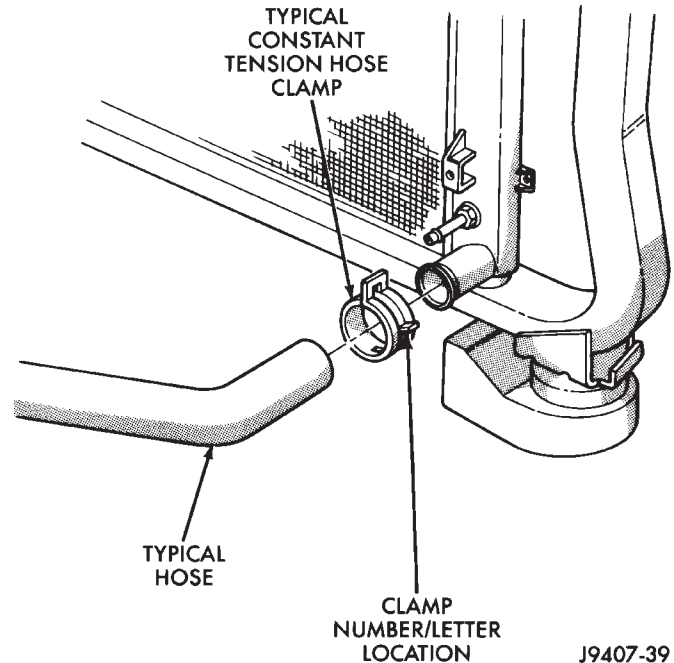


Fig. 44 Clamp Number/Letter Location

- (1) Disconnect the negative battery cable at battery.
- (2) Observe the previous WARNINGS and CAUTIONS.
- (3) Drain coolant from radiator. Refer to Draining Cooling System in this group.
- (4) **4.0L Engine:** Remove the four fan hub-to-water pump pulley mounting nuts (Fig. 46). Carefully remove the fan assembly from the water pump pulley and position to center of fan shroud. Fan belt removal is not necessary as the water pump studs will hold the pump pulley in position.
- (5) Do not remove fan/viscous fan drive assembly from vehicle at this time.
- (6) **5.2/5.9L Engines:** The thermal viscous fan drive is attached (threaded) to the water pump hub shaft (Fig. 47). Remove fan/viscous fan drive assembly from water pump by turning mounting nut counterclockwise as viewed from front. Threads on viscous fan drive are **RIGHT HAND**. A Snap-On 36 MM Fan Wrench (number SP346 from Snap-On Cummins Diesel Tool Set number 2017DSP) can be used. Place a bar or screwdriver between water pump pulley bolts (Fig. 47) to prevent pulley from rotating. Drive belt removal is not necessary for removal of fan drive.
- (7) Do not attempt to remove fan/viscous fan drive assembly from vehicle at this time.

REMOVAL AND INSTALLATION (Continued)

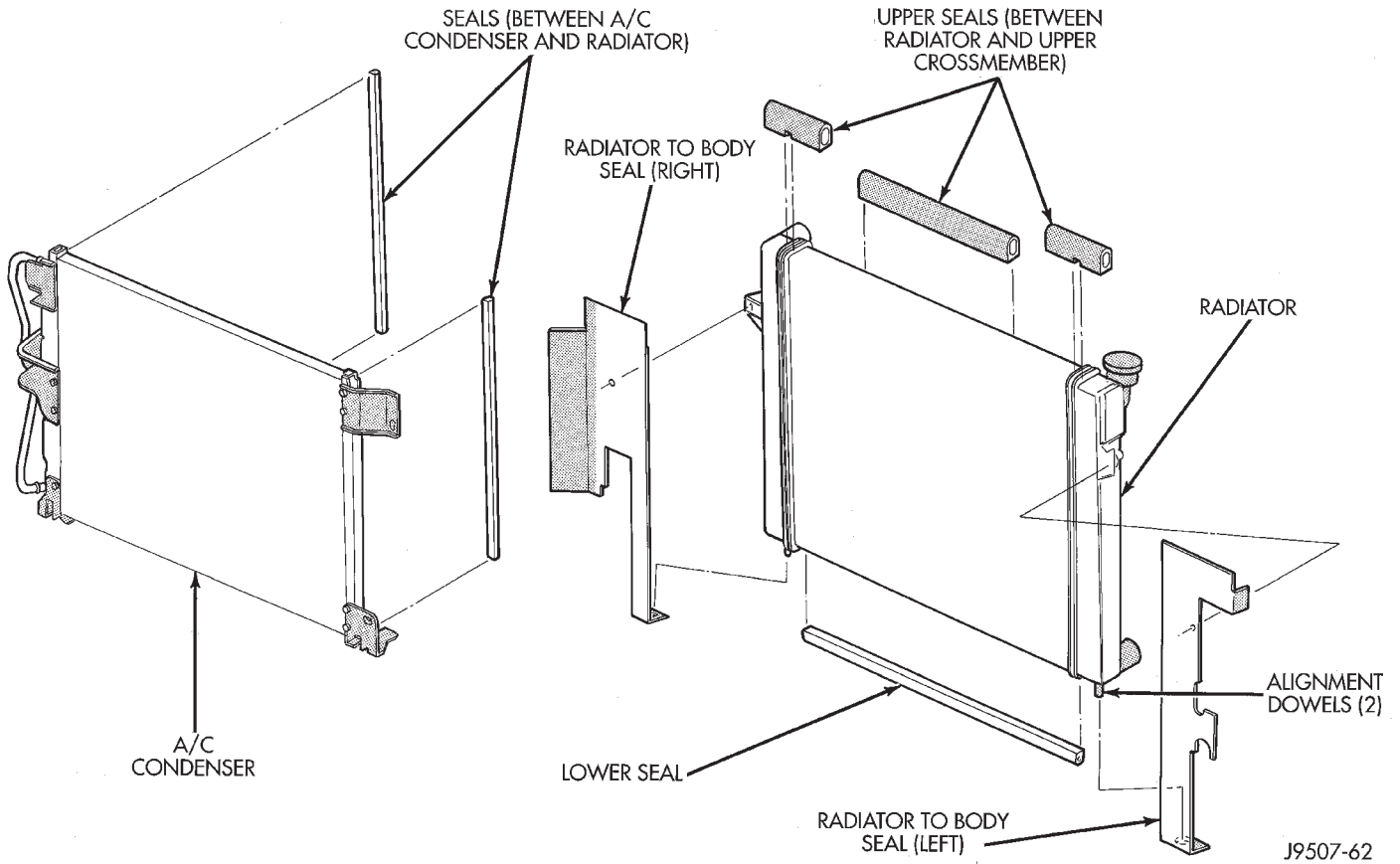


Fig. 45 Air Seals—Typical

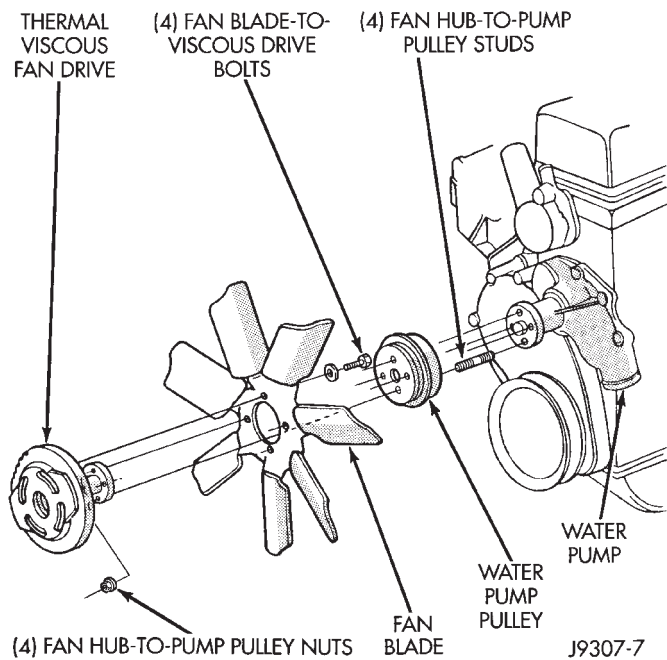


Fig. 46 Fan Mounting Nuts—4.0L 6-Cyl. Engine

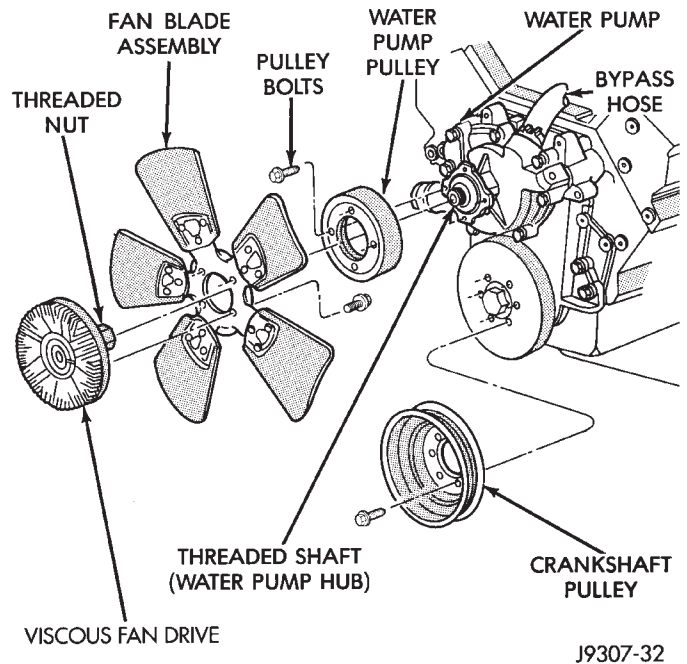


Fig. 47 Fan Blade and Viscous Fan Drive—5.2/5.9L V-8 Engines

REMOVAL AND INSTALLATION (Continued)

(8) Remove the two fan shroud-to-upper radiator crossmember mounting nuts (Fig. 48).

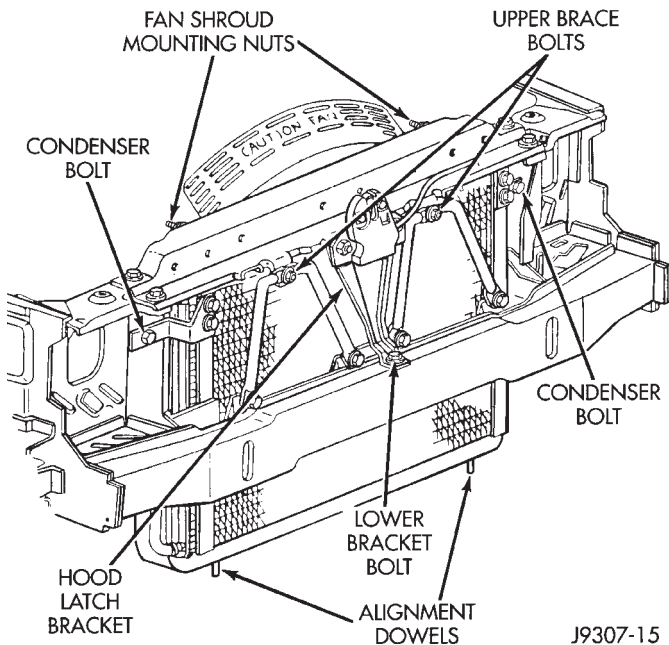


Fig. 48 Radiator and A/C Condenser Mounting

(9) Remove the fan assembly and fan shroud (as one unit) from vehicle.

(10) Special quick-connect fittings are used to join the transmission cooling lines to the radiator. Removal procedures are different between the 4.0L and 5.2/5.9L engines. Disconnect the cooling lines from the radiator. Refer to Group 21 for transmission cooling line removal and installation.

(11) The radiator upper crossmember (Fig. 49) can be adjusted left or right through the use of slotted holes. Before removal, mark the original position of the crossmember.

(12) Eight clips are used to retain a rubber seal (Fig. 49) to the body and upper radiator crossmember. Gently pry up the outboard clips (two per side) until rubber seal can be removed. Do not remove the clips entirely. Fold back the seal on both sides for access to (the hidden) grille opening reinforcement mounting bolts (Fig. 49). Remove these two bolts.

(13) Remove the grill. Refer to group 23, Body.

(14) Remove the upper brace bolt from each of the two radiator braces (Fig. 48).

(15) Remove the two crossmember-to-radiator mounting nuts (Fig. 49).

(16) Working through grill opening, remove the lower bracket bolt securing lower part of hood latch support bracket to lower frame crossmember (Fig. 48).

(17) Remove the remaining four bolts securing the radiator upper crossmember to the body. Do not remove the hood latch or hood latch cable from the

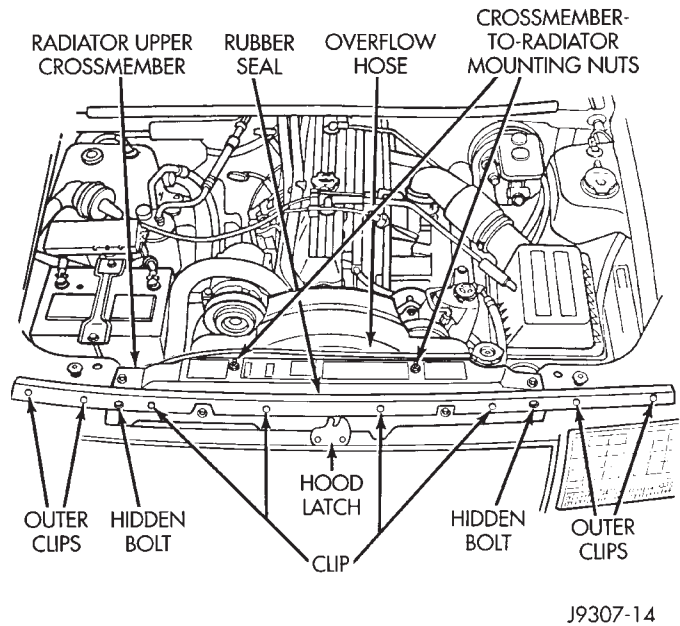


Fig. 49 Radiator Upper Crossmember—Typical

crossmember. Lift the crossmember straight up and lay to the side.

(18) Equipped with air conditioning: Remove the two A/C condenser-to-radiator mounting bolts (Fig. 48). These two bolts are also used to retain the side mounted rubber air seals (Fig. 45). These seals are compressed between the A/C condenser and the radiator. The lower part of the air seals are compressed between the radiator and the A/C condenser mounting brackets (Fig. 50).

(19) Not equipped with air conditioning: Remove the two bolts retaining the side mounted rubber air seals (Fig. 45) to the radiator. The lower part of the air seals are compressed between the radiator and the radiator lower crossmember.

CAUTION: Note the location of all rubber air seals (Fig. 45). To prevent overheating, they must be installed back to their original positions.

(20) Disconnect the coolant reserve/overflow tank hose (Fig. 49) at radiator.

(21) Remove upper radiator hose at radiator. A special clamp tool (Fig. 43) must be used to remove the constant tension hose clamps.

(22) 4.0L Engine Only: Remove the lower radiator hose at the water pump end.

(23) To gain access to lower radiator hose clamp at radiator, gently lift the radiator a slight amount. Remove hose clamp and hose.

(24) The lower part of radiator is equipped with two alignment dowel pins (Fig. 48) (Fig. 50). They are located on the bottom of radiator tank and fit

REMOVAL AND INSTALLATION (Continued)

into rubber grommets. These rubber grommets are pressed into the radiator lower crossmember.

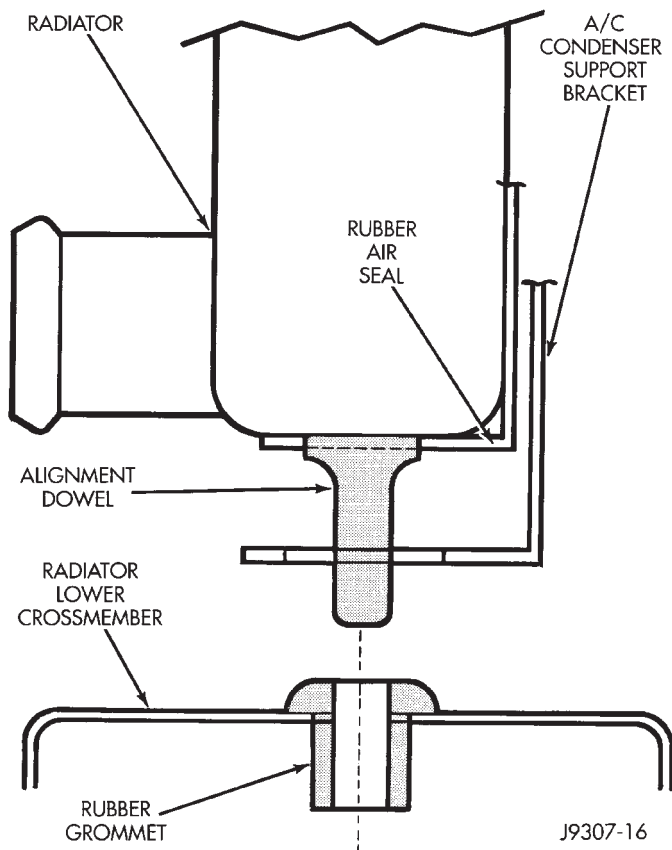


Fig. 50 Radiator Alignment Dowels

WARNING: THE AIR CONDITIONING SYSTEM (IF EQUIPPED) IS UNDER A CONSTANT PRESSURE EVEN WITH THE ENGINE OFF. REFER TO REFRIGERANT WARNINGS IN GROUP 24, HEATING AND AIR CONDITIONING BEFORE HANDLING ANY AIR CONDITIONING COMPONENT.

(25) If equipped with an auxiliary automatic transmission oil cooler, use caution when removing radiator. The oil cooler lines are routed through a rubber air seal on the left side of radiator. Do not cut or tear this seal.

(26) Gently lift up and remove radiator from vehicle. Be careful not to scrape the radiator fins against any other component. Also be careful not to disturb the air conditioning condenser (if equipped).

INSTALLATION

CAUTION: Before installing the radiator or A/C condenser, be sure the radiator-to-body and radiator-to-A/C condenser rubber air seals (Fig. 45) are properly fastened to their original positions. These are used at the top, bottom and sides of the radiator and A/C condenser. To prevent overheating, these seals must be installed to their original positions.

(1) Equipped with air conditioning: Gently lower the radiator into the vehicle. Guide the two radiator alignment dowels through the holes in the rubber air seals first and then through the A/C support brackets (Fig. 50). Continue to guide the alignment dowels into the rubber grommets located in lower radiator crossmember (Fig. 50). The holes in the L-shaped brackets (located on bottom of A/C condenser) must be positioned between bottom of rubber air seals and top of rubber grommets.

(2) Not equipped with air conditioning: Gently lower the radiator into the vehicle. Guide the two radiator alignment dowels through the holes in the rubber air seals. Continue to guide the alignment dowels into the rubber grommets located in lower radiator crossmember.

(3) Connect the lower radiator hose and hose clamp to radiator.

CAUTION: The tangs on the hose clamp must be positioned straight down.

(4) 4.0L Engine: Connect the lower radiator hose at the water pump.

(5) Connect the upper radiator hose at the radiator.

(6) Equipped with air conditioning: Install the two A/C condenser-to-radiator mounting bolts (Fig. 48). These two bolts are also used to retain the rubber air seal (Fig. 45) to the sides of radiator.

(7) Not equipped with A/C: Install the two bolts retaining the rubber air seal (Fig. 45) to sides of radiator.

(8) Install coolant reserve/overflow tank hose at radiator.

(9) If radiator-to-upper crossmember rubber isolators were removed from radiator, install them. Tighten mounting nuts to 3 N·m (24-36 in. lbs.) torque. Position upper radiator crossmember to radiator.

REMOVAL AND INSTALLATION (Continued)

(10) Working through grill opening, install and tighten the hood latch support bracket-to-lower frame crossmember bolt (Fig. 48).

(11) Install the four bolts securing the radiator upper crossmember to the body (Fig. 49).

(12) Install two nuts securing the radiator to the upper radiator crossmember (Fig. 49). Tighten nuts to 2 N·m (18-21 in. lbs.) torque.

(13) Install the upper bolt to each radiator brace (Fig. 48).

(14) Install the grill. Refer to group 23, Body.

(15) Install the rubber seal (Fig. 49) to the four (outer) seal mounting clips on vehicle body. Press down on clips until seated.

(16) Install the transmission cooler lines to radiator. Refer to Group 21 for installation.

(17) Position the fan assembly and fan shroud (as one unit) to the vehicle.

(18) Position fan shroud to radiator. Be sure the alignment tabs at the lower part of shroud are placed into the slots near lower part of radiator.

Be sure the upper and lower portions of the fan shroud are firmly connected. All air must flow through the radiator.

(19) Install the two nuts securing the fan shroud to the upper radiator crossmember (Fig. 48).

(20) 4.0L Engine: Install the four nuts securing the fan assembly to the water pump (Fig. 46). Tighten nuts to 27 N·m (20 ft. lbs.) torque.

(21) 5.2/5.9L Engines: Install the fan/viscous fan drive assembly to the water pump.

(22) Rotate the fan blades (by hand) and check for interference at fan shroud.

(23) Be sure of at least 25 mm (1.0 inches) between tips of fan blades and fan shroud.

(24) Fill cooling system. Refer to Refilling Cooling System in this group.

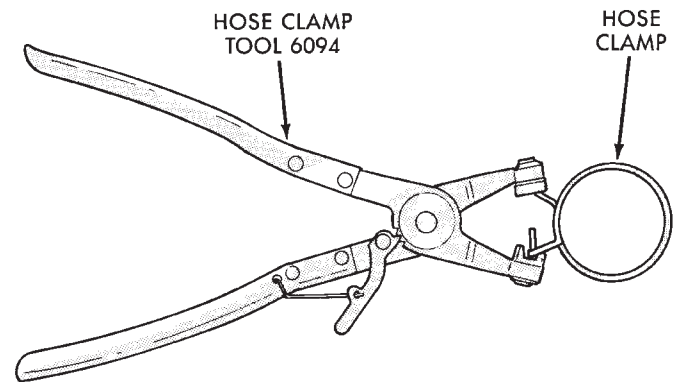
(25) Connect battery cable at battery.

(26) Start and warm engine. Check for leaks.

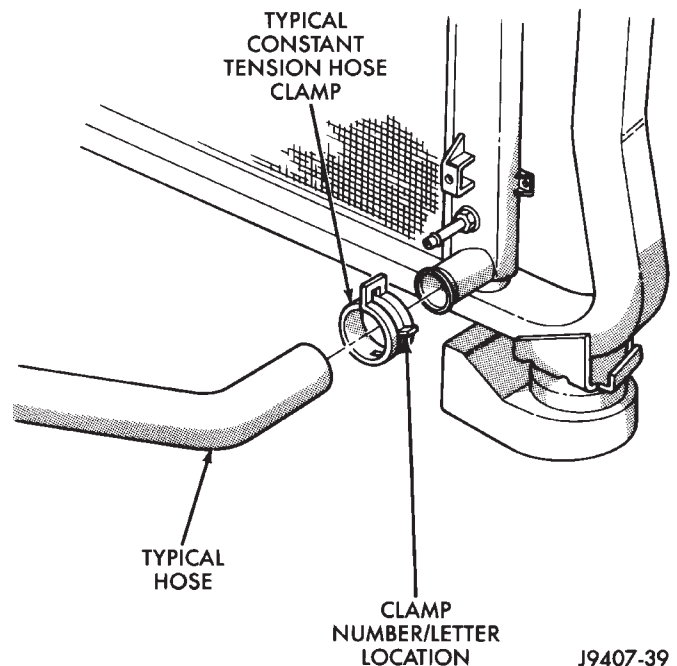
WATER PUMP BYPASS HOSE—5.2L/5.9L**REMOVAL**

WARNING: CONSTANT TENSION HOSE CLAMPS ARE USED ON MOST COOLING SYSTEM HOSES. WHEN REMOVING OR INSTALLING, USE ONLY TOOLS DESIGNED FOR SERVICING THIS TYPE OF CLAMP, SUCH AS SPECIAL CLAMP TOOL (NUMBER 6094) (Fig. 51). SNAP-ON CLAMP TOOL (NUMBER HPC-20) MAY BE USED FOR LARGER CLAMPS. ALWAYS WEAR SAFETY GLASSES WHEN SERVICING CONSTANT TENSION CLAMPS.

CAUTION: A number or letter is stamped into the tongue of constant tension clamps (Fig. 52). If replacement is necessary, use only an original equipment clamp with matching number or letter.



J9207-36

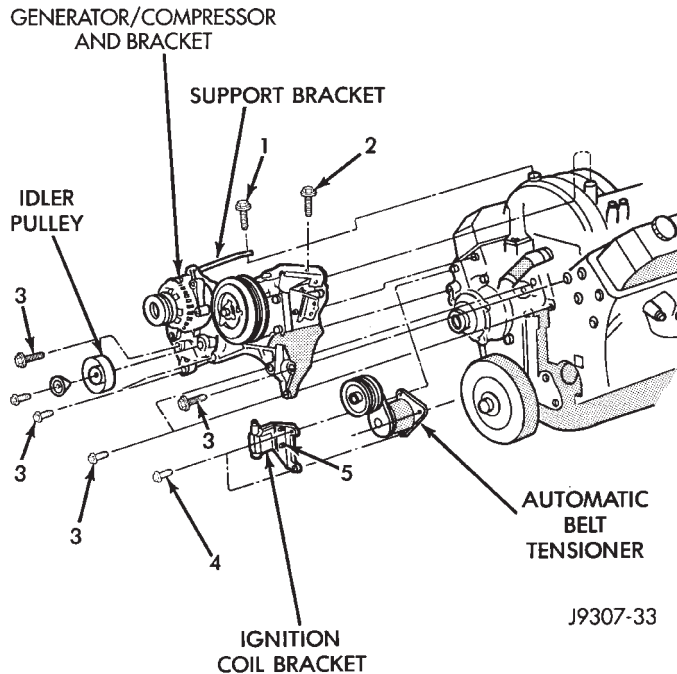
Fig. 51 Hose Clamp Tool—Typical

J9407-39

Fig. 52 Clamp Number/Letter Location

If equipped with A/C, the generator and A/C compressor along with their common mounting bracket (Fig. 53) must be partially removed. Removing generator or A/C compressor from their mounting bracket is not necessary. Also, discharging A/C system is not necessary. **Do not** remove any refrigerant lines from A/C compressor.

REMOVAL AND INSTALLATION (Continued)



J9307-33

Fig. 53 Generator and A/C Compressor Mounting Bracket—5.2/5.9L Engines

WARNING: THE A/C SYSTEM IS UNDER PRESSURE EVEN WITH ENGINE OFF. REFER TO REFRIGERANT WARNINGS IN GROUP 24, HEATING AND AIR CONDITIONING.

(1) Disconnect negative battery cable from battery.
 (2) Partially drain cooling system. Refer to Draining Cooling System in this group.

Do not waste reusable coolant. If solution is clean, drain coolant into a clean container for reuse.

(3) Remove upper radiator hose clamp (Fig. 51) and hose at radiator.

(4) Unplug wiring harness from A/C compressor.

(5) Remove air duct at throttle body.

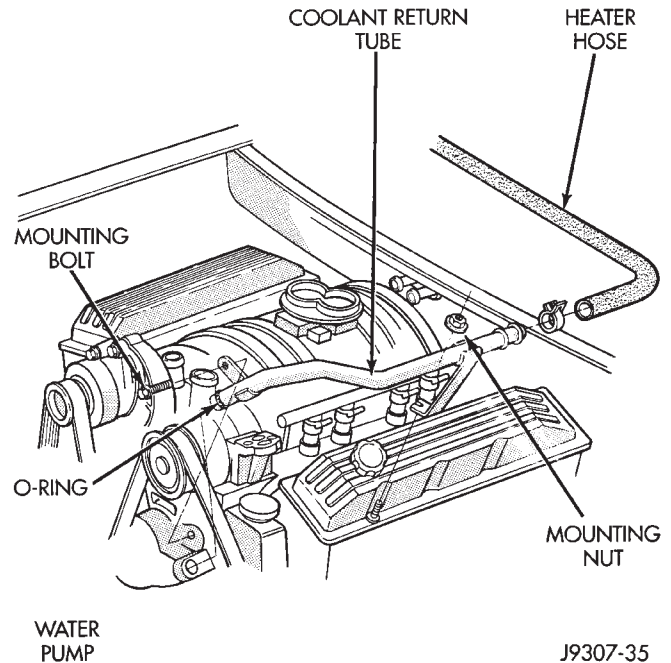
(6) Disconnect A/C lines from clip at intake manifold.

(7) Remove heater hose coolant return tube mounting bolt and nut (Fig. 54). Remove tube from engine and discard the old tube o-ring.

(8) Remove accessory drive belt as follows: The drive belt is equipped with a spring loaded automatic belt tensioner (Fig. 55). Relax tension from belt by rotating tensioner clockwise (as viewed from front) (Fig. 55). When all belt tension has been relaxed, remove accessory drive belt.

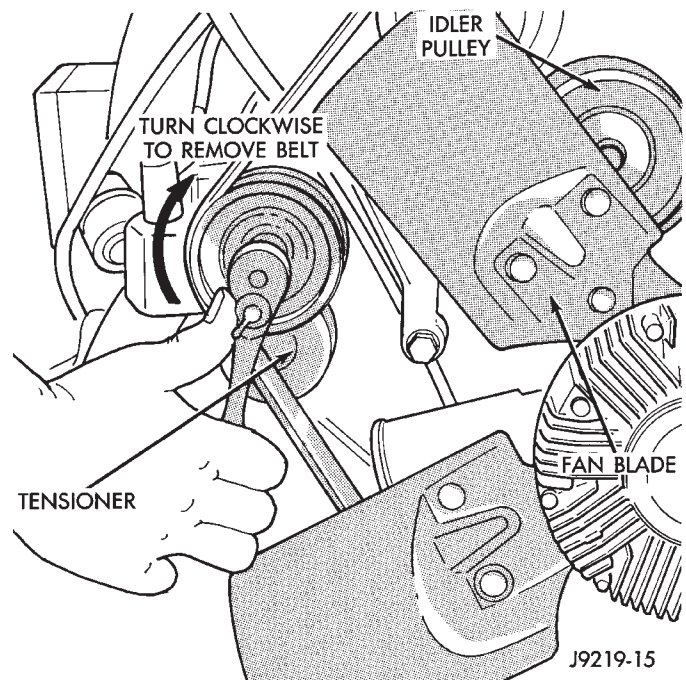
(9) The drive belt idler pulley must be removed to gain access to one of A/C compressor/generator bracket mounting bolts. Remove idler pulley bolt and remove idler pulley (Fig. 53).

(10) Remove oil dipstick tube mounting bolt at side of A/C- generator mounting bracket.



J9307-35

Fig. 54 Coolant Return Tube—5.2/5.9L Engines



J9219-15

Fig. 55 Belt Tensioner Assembly—5.2/5.9L Engines

(11) Disconnect speed control cable and throttle cable at throttle body. Refer to Accelerator Pedal and Throttle Cable in Group 14, Fuel System for throttle cable removal and installation. Refer to Group 8H for removal and installation of speed control cable.

(12) Remove bracket-to-intake manifold bolts (number 1 and 2) (Fig. 53).

(13) Remove bracket bolts (Fig. 53).

(14) Lift and position generator and A/C compressor (along with their common mounting bracket) to

REMOVAL AND INSTALLATION (Continued)

gain access to bypass hose. A block of wood may be used to hold assembly in position.

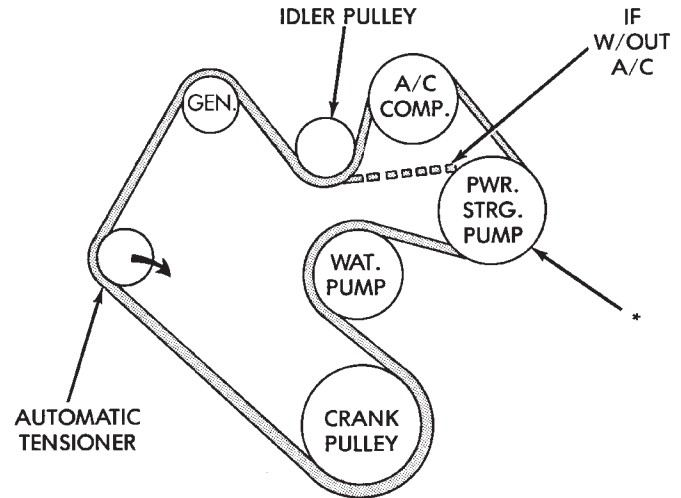
(15) Loosen and position both hose clamps to center of bypass hose. Remove hose from vehicle.

INSTALLATION

- (1) Position bypass hose clamps to center of hose.
- (2) Install bypass hose to engine.
- (3) Secure both hose clamps (Fig. 51).
- (4) Install generator-A/C mounting bracket assembly to engine. Tighten bolts (number 1 and 2) (Fig. 53) to 54 N·m (40 ft. lbs.) torque. Tighten bolts (number 3) (Fig. 53) to 40 N·m (30 ft. lbs.) torque.
- (5) Install a new o-ring to the heater hose coolant return tube (Fig. 54). Coat the new o-ring with anti-freeze before installation.
- (6) Install coolant return tube to engine (Fig. 54). Be sure the slot in tube bracket is bottomed to the mounting bolt. This will properly position return tube.
- (7) Connect throttle body control cables.
- (8) Install oil dipstick mounting bolt.
- (9) Install idler pulley. Tighten pulley bolt to 54 N·m (40 ft. lbs.) torque.
- (10) Relax tension from belt tensioner (Fig. 55). Install drive belt.

CAUTION: When installing serpentine accessory drive belt, belt must be routed correctly. If not, engine may overheat due to water pump rotating in wrong direction. Refer to (Fig. 56) for correct belt routing. Or, refer to the Belt Routing Label located in the engine compartment. The correct belt with correct length must be used.

- (11) Install air duct to throttle body.
- (12) Install upper radiator hose to radiator.
- (13) Connect wiring harness to A/C compressor.
- (14) Connect A/C lines to clip at intake manifold.
- (15) Fill cooling system. Refer to Refilling the Cooling System in this group.
- (16) Start and warm the engine. Check for leaks.



*IF VEHICLE IS NOT EQUIPPED WITH POWER STEERING, THIS WILL BE AN IDLER PULLEY.

J9307-26

Fig. 56 Belt Routing—5.2/5.9L Engines

BLOCK HEATER**REMOVAL**

- (1) Disconnect battery negative cable.
- (2) Drain coolant from radiator. Refer to Draining Cooling System in this group.
- (3) Raise vehicle.
- (4) Remove engine cylinder block drain plug(s) located on the sides of cylinder block above the oil pan rail (Fig. 57) (Fig. 58).

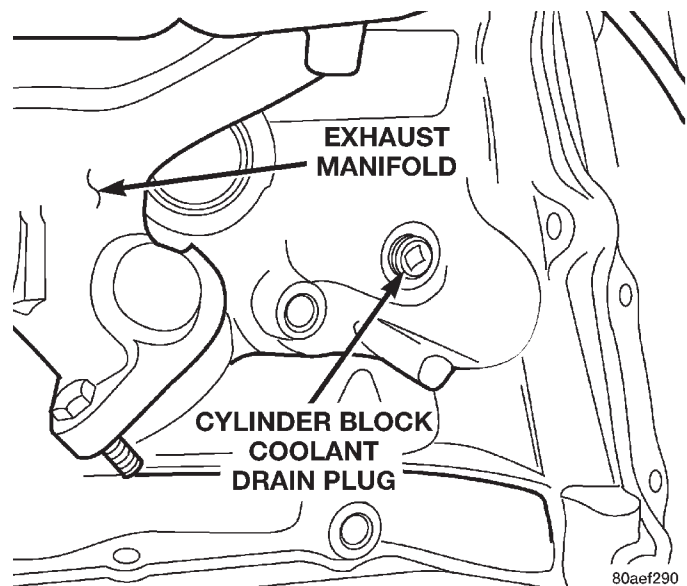


Fig. 57 Cylinder Block Drain Plug—4.0L Engine

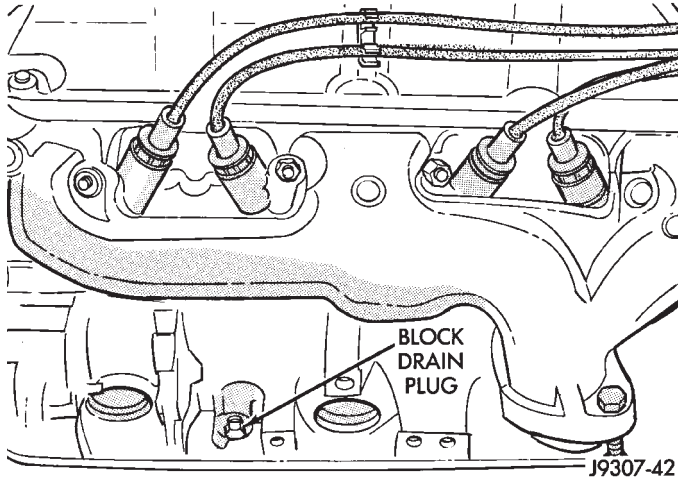
REMOVAL AND INSTALLATION (Continued)

Fig. 58 Cylinder Block Drain Plug—5.2/5.9L Engines—Typical

(5) Remove power cord from block heater (Fig. 59) (Fig. 60).

(6) Loosen screw at center of block heater. Remove heater assembly.

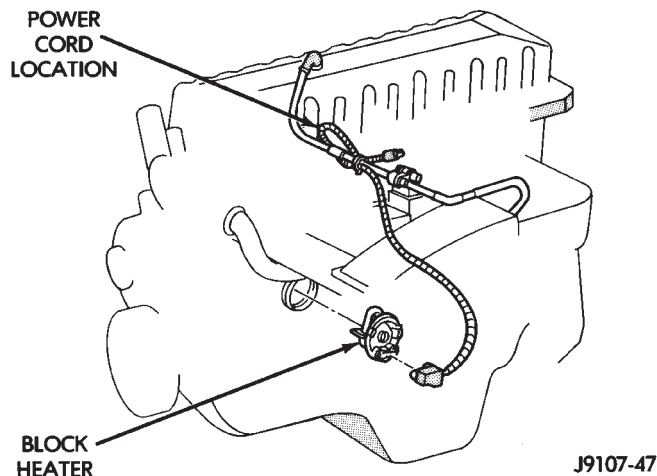


Fig. 59 Block Heater—4.0L Engine

INSTALLATION

(1) Thoroughly clean cylinder block core hole and block heater seat.

(2) Insert block heater assembly with element loop pointing down.

(3) With block heater fully seated, tighten center screw to 4 N·m (32 in. lbs.) torque on 4.0L engines and 2 N·m (17 in. lbs.) torque on 5.2L/5.9L engines.

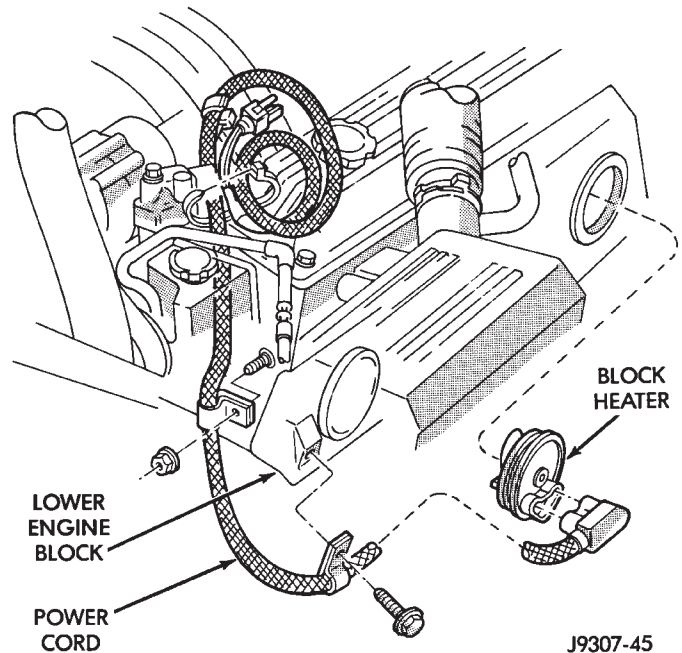


Fig. 60 Block Heater—5.2/5.9L Engines

(4) Fill cooling system with recommended coolant. Refer to Refilling Cooling System section in this group.

(5) Start and warm the engine. Check for leaks.

ACCESSORY DRIVE BELT

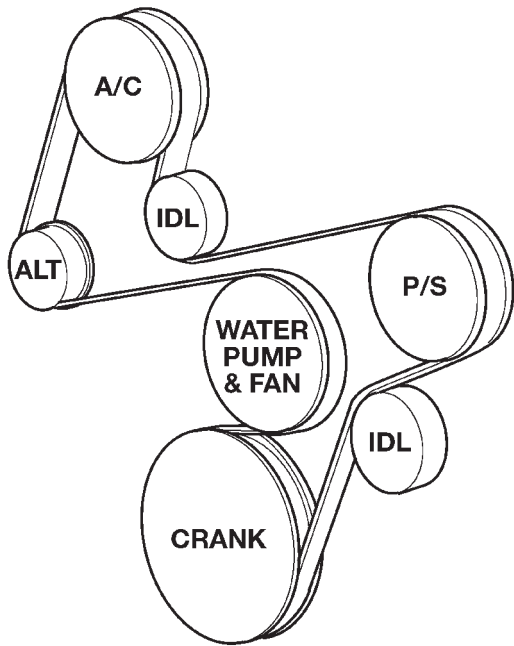
Correct drive belt tension is required to ensure optimum performance of the belt driven engine accessories. There are different types of adjustment gauges for checking either a serpentine or a V-type belt. Refer to the instructions supplied with the gauge. Use the correct gauge when checking belt tension. Place gauge in the middle of the section of belt being tested (between two pulleys) to check tension. Do not allow the gauge (or gauge adapter) to contact anything but the belt.

BELT SCHEMATICS

The belt routing schematics are published from the latest information available at the time of publication. Vehicles not equipped with Power Steering have an idler pulley in place of the power steering pump pulley. **If anything differs between these schematics and the Belt Routing Label, use the schematics on Belt Routing Label.** This label is located in the engine compartment.

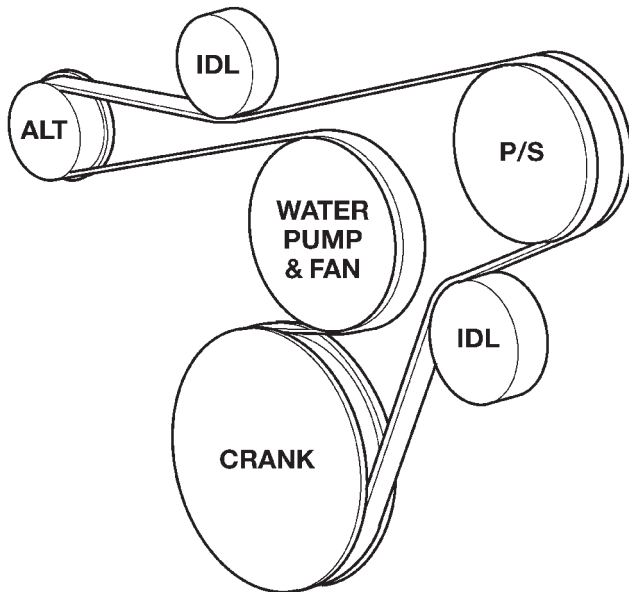
REMOVAL AND INSTALLATION (Continued)

Refer to (Fig. 61) (Fig. 62) for correct belt routing, or refer to Belt Routing Label located in the vehicle engine compartment.



80abd2ad

Fig. 61 4.0L Engines



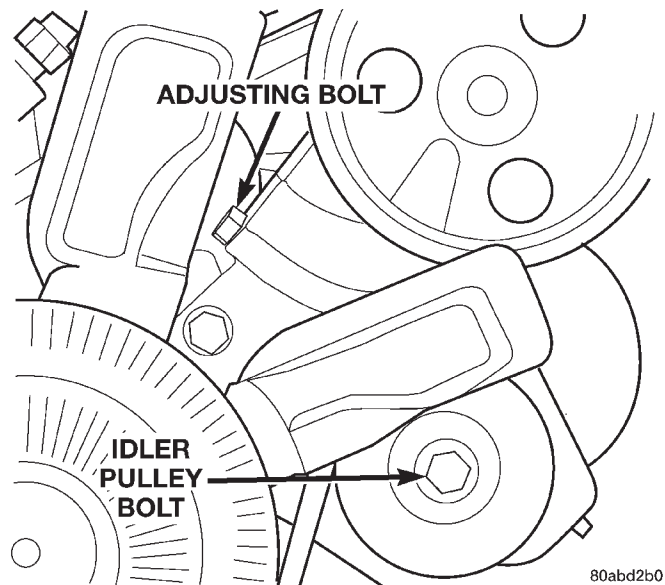
80abd2ae

Fig. 62 5.2/5.9L Engines

BELT REPLACEMENT—4.0L ENGINES**REMOVAL**

Belt tension is adjusted at the power steering pump bracket and idler pulley assembly.

- (1) Disconnect negative battery cable from battery.
- (2) Loosen idler pulley bolt (Fig. 63).
- (3) Loosen tension adjusting bolt (Fig. 63) and remove accessory drive belt.



80abd2b0

Fig. 63 Power Steering Pump Bracket and Idler Pulley

INSTALLATION

- (1) Check condition of all pulleys.

CAUTION: When installing the serpentine accessory drive belt, the belt **MUST** be routed correctly. If not, the engine may overheat due to the water pump rotating in the wrong direction. Refer to (Fig. 61) for correct belt routing.

- (2) Install new belt. Install belt tension gauge C-4162 and tighten adjustment bolt (Fig. 63) until belt tension is within specification range. Refer to the end of this group for Drive Belt Tension specifications.

- (3) Tighten idler pulley bolt and re-check belt tension. Adjust if necessary.

BELT REPLACEMENT—5.2L/5.9L ENGINES

Drive belts on the 5.2L/5.9L engines are equipped with a spring loaded automatic belt tensioner (Fig. 64).

CAUTION: Do not attempt to check belt tension with a belt tension gauge on vehicles equipped with an automatic belt tensioner. Refer to Automatic Belt Tensioner in this group.

REMOVAL AND INSTALLATION (Continued)

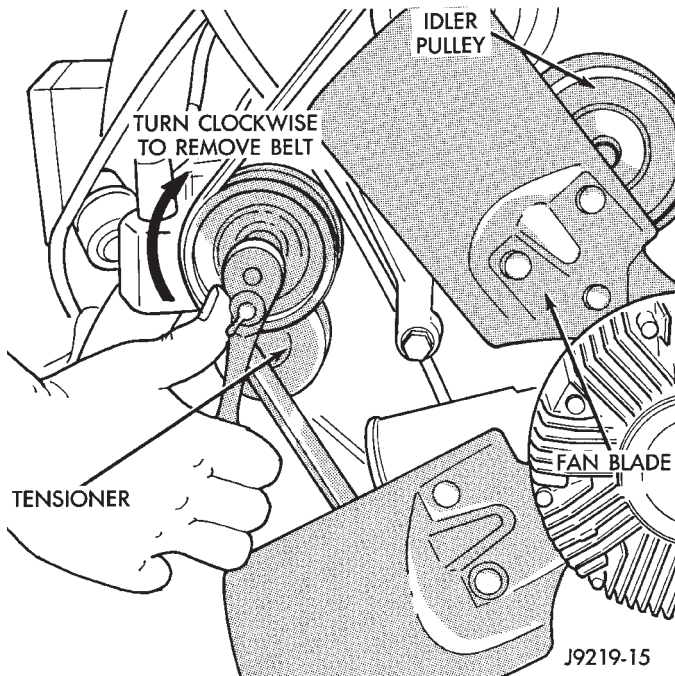


Fig. 64 Belt Tensioner—5.2/5.9L Engines

REMOVAL

- (1) Attach a socket/wrench to pulley mounting bolt of automatic belt tensioner (Fig. 64).
- (2) Rotate tensioner assembly clockwise (as viewed from front) until tension has been relieved from belt.
- (3) Remove belt from idler pulley first.
- (4) Remove belt from vehicle.

INSTALLATION

CAUTION: When installing serpentine accessory drive belt, the belt must be routed correctly. If not, engine may overheat due to water pump rotating in wrong direction. Refer to (Fig. 62) for correct engine belt routing. The correct belt with correct length must be used.

- (1) Position drive belt over all pulleys **except** idler pulley. This pulley is located between generator and A/C compressor.
- (2) Attach a socket/wrench to pulley mounting bolt of automatic tensioner (Fig. 64).
- (3) Rotate socket/wrench clockwise. Place belt over idler pulley. Let tensioner rotate back into place. Remove wrench. Be sure belt is properly seated on all pulleys.
- (4) Check belt indexing marks. Refer to Automatic Belt Tensioner.

AUTOMATIC BELT TENSIONER

NOTE: On 5.2/5.9L engines, the tensioner is equipped with an indexing arrow (Fig. 65) on back of tensioner and an indexing mark on tensioner housing. If a new belt is being installed, arrow must be within approximately 3 mm (1/8 in.) of indexing mark (point B-) (Fig. 65). Belt is considered new if it has been used 15 minutes or less.

- If the above specification cannot be met, check for:
- The wrong belt being installed (incorrect length/width)
 - Worn bearings on an engine accessory (A/C compressor, power steering pump, water pump, idler pulley or generator)
 - A pulley on an engine accessory being loose
 - Misalignment of an engine accessory
 - Belt incorrectly routed.

NOTE: A used belt should be replaced if tensioner indexing arrow has moved to point-A (Fig. 65). Tensioner travel stops at point-A.

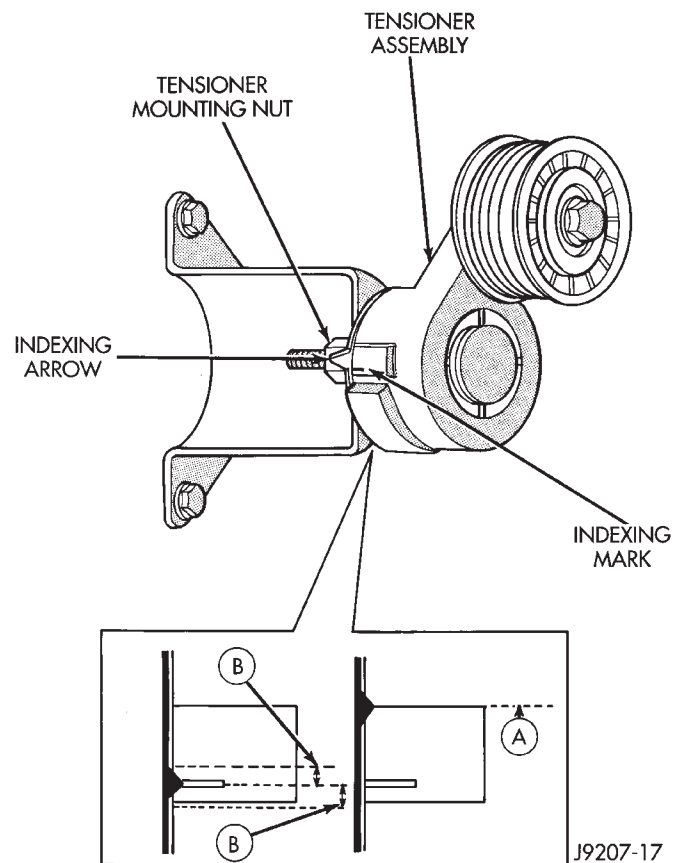


Fig. 65 Belt Tensioner/Pulley Assembly—5.2/5.9L Engines

REMOVAL AND INSTALLATION (Continued)**REMOVAL**

(1) Remove accessory drive belt. Refer to Belt Replacement/Adjustment in this group.

(2) Disconnect wiring and secondary cable from ignition coil.

(3) Remove ignition coil from coil mounting bracket (two bolts). Do not remove coil mounting bracket from cylinder head.

(4) Remove tensioner assembly from mounting bracket (one nut) (Fig. 65).

WARNING: BECAUSE OF HIGH SPRING PRESSURE, DO NOT ATTEMPT TO DISASSEMBLE AUTOMATIC TENSIONER. UNIT IS SERVICED AS AN ASSEMBLY (EXCEPT FOR PULLEY).

(5) Remove pulley bolt. Remove pulley from tensioner.

INSTALLATION

(1) Install pulley and pulley bolt to tensioner. Tighten bolt to 61 N·m (45 ft. lbs.) torque.

(2) Install tensioner assembly to mounting bracket. An indexing tab is located on back of tensioner. Align this tab to slot in mounting bracket. Tighten nut to 67 N·m (50 ft. lbs.) torque.

(3) Connect all wiring to ignition coil.

(4) Install coil to coil bracket. If nuts and bolts are used to secure coil to coil bracket, tighten to 11 N·m (100 in. lbs.) torque. If coil mounting bracket has been tapped for coil mounting bolts, tighten bolts to 5 N·m (50 in. lbs.) torque.

CAUTION: To prevent damage to coil case, coil mounting bolts must be torqued.

(5) Install drive belt. Refer to Belt Removal/Installation in this group.

(6) Check belt indexing marks (Fig. 65).

COOLING SYSTEM FAN—4.0L ENGINE**REMOVAL**

(1) Remove the four fan hub-to-water pump pulley mounting nuts (Fig. 66). Carefully remove the fan assembly from the water pump pulley and position to center of fan shroud. Fan belt removal is not necessary as the water pump studs will hold the pump pulley in position. Do not remove fan assembly from vehicle at this time.

(2) Remove the two fan shroud-to-upper radiator crossmember mounting nuts (Fig. 67).

(3) Remove fan, viscous fan drive and fan shroud as an assembly from the vehicle.

(4) Remove the four fan blade-to-viscous fan drive mounting bolts. Remove viscous fan drive from fan blades.

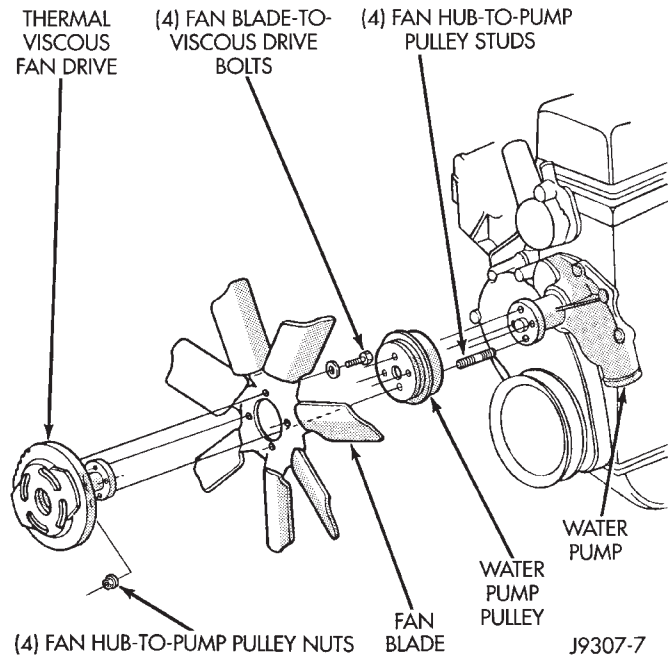


Fig. 66 Fan Mounting Nuts—4.0L 6-Cyl. Engine

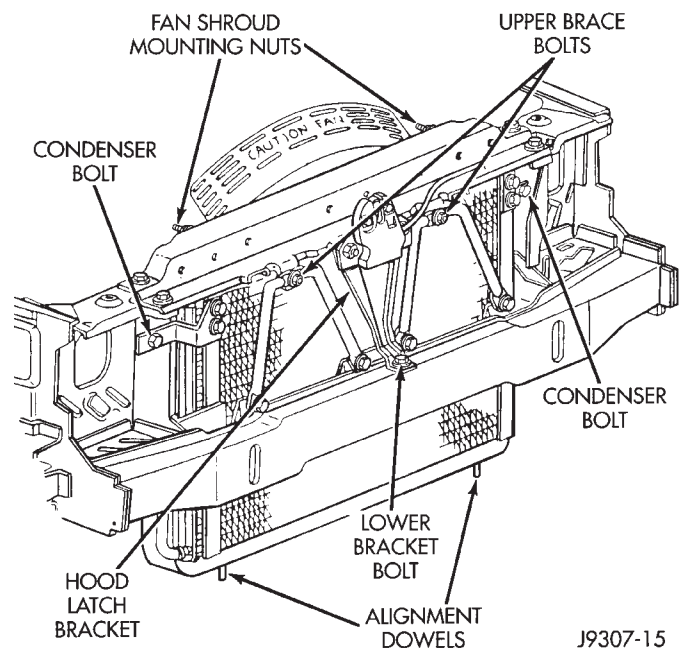


Fig. 67 Fan Shroud Mounting Nuts

(5) After removing fan blade/fan drive assembly **do not** place the thermal viscous fan drive in the horizontal position. If stored horizontally, the silicone fluid in the viscous fan drive could drain into the bearing assembly and contaminate the lubricant.

INSTALLATION

(1) Assemble fan blades to viscous fan drive. Tighten mounting bolts to 24 N·m (18 ft. lbs.) torque.

REMOVAL AND INSTALLATION (Continued)

(2) Position fan, viscous fan drive and fan shroud to the engine as one assembly.

(3) Position fan shroud to radiator. Be sure the alignment tabs at the lower part of shroud are placed into the slots near lower part of radiator.

Be sure the upper and lower portions of the fan shroud are firmly connected. All air must flow through the radiator.

(4) Position mounting flange of fan/viscous fan drive assembly onto water pump pulley. Install four nuts and tighten to 24 N-m (18 ft. lbs.) torque.

(5) Install two fan shroud mounting nuts.

Be sure of at least 25 mm (1.0 inches) between tips of fan blades and fan shroud.

(4) Do not unbolt fan blade assembly from viscous fan drive at this time.

(5) Remove two fan shroud-to-upper crossmember nuts (Fig. 67).

(6) Remove fan shroud and fan blade/viscous fan drive assembly as a complete unit from vehicle.

(7) After removing fan blade/viscous fan drive assembly, **do not** place viscous fan drive in horizontal position. If stored horizontally, silicone fluid in the viscous fan drive could drain into its bearing assembly and contaminate lubricant.

CAUTION: Do not remove water pump pulley-to-water pump bolts. This pulley is under spring tension.

(8) Remove four bolts securing fan blade assembly to viscous fan drive.

COOLING SYSTEM FAN—5.2L ENGINE

REMOVAL

(1) Disconnect negative battery cable from battery.

(2) The thermal viscous fan drive/fan blade assembly is attached (threaded) to water pump hub shaft (Fig. 68). Remove fan blade/viscous fan drive assembly from water pump by turning mounting nut counterclockwise as viewed from front. Threads on viscous fan drive are **RIGHT HAND**. A Snap-On 36 MM Fan Wrench (number SP346 from Snap-On Cummins Diesel Tool Set number 2017DSP) can be used. Place a bar or screwdriver between water pump pulley bolts to prevent pulley from rotating.

(3) Do not attempt to remove fan/viscous fan drive assembly from vehicle at this time.

INSTALLATION

(1) Install fan blade assembly to viscous fan drive. Tighten bolts to 23 N-m (17 ft. lbs.) torque.

(2) Position fan shroud and fan blade/viscous fan drive assembly to vehicle as a complete unit.

(3) Position fan shroud to radiator. Be sure the alignment tabs at the lower part of shroud are placed into the slots near lower part of radiator. Install and tighten the two fan shroud-to-upper crossmember mounting nuts.

Be sure of at least 25 mm (1.0 inches) between tips of fan blades and fan shroud.

(4) Install fan blade/viscous fan drive assembly to water pump shaft.

(5) Connect negative battery cable.

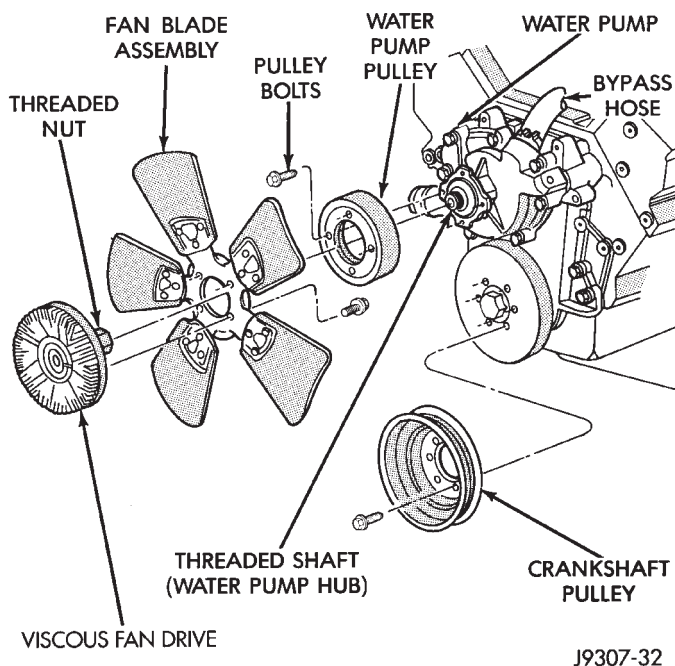


Fig. 68 Fan Blade/Viscous Fan Drive—5.2L V-8 Engines

ELECTRIC COOLING FAN—5.9L ENGINE

WARNING: THE FAN CAN COME ON AT ANY TIME WHEN THE IGNITION KEY IS IN THE "RUN" POSITION. MAKE SURE TO TURN THE KEY TO "OFF" WHEN SERVICING THIS COMPONENT.

REMOVAL

(1) Disconnect battery negative cable.

(2) Partially drain cooling system to allow upper radiator hose removal from radiator.

(3) Disconnect upper hose coolant switch connector (Fig. 69).

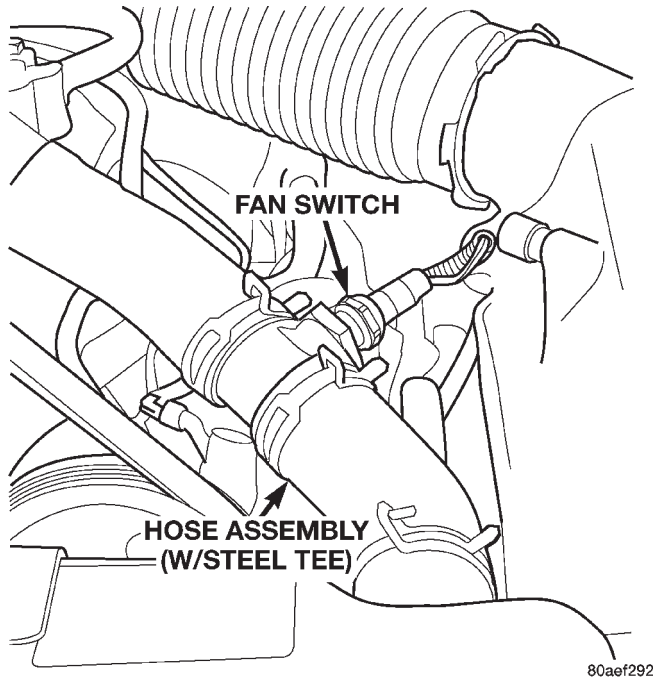
(4) Remove clamp from upper hose/radiator connection and remove hose from radiator inlet only. Secure hose out of way.

(5) Disconnect the cooling fan electrical connector (Fig. 70).

(6) Remove cooling fan module mounting bolts (Fig. 70).

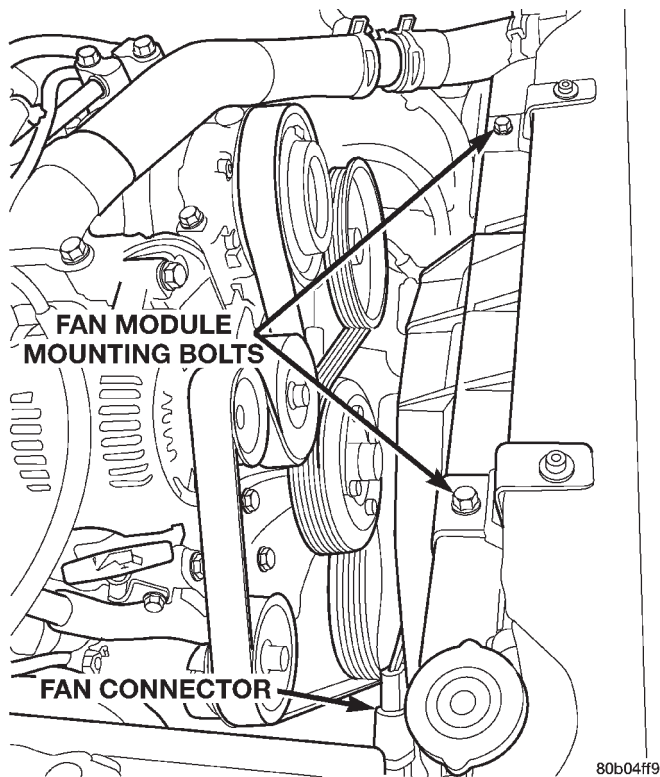
REMOVAL AND INSTALLATION (Continued)

(7) Lift fan module up off of mounts and out of engine compartment.



80aef292

Fig. 69 Upper Hose Coolant Switch



80b04ff9

Fig. 70 Fan Module Removal/Installation

INSTALLATION

If replacing fan module assembly, transfer any brackets, etc. not included with new module assembly.

(1) Lower fan module into engine compartment and into its respective radiator mounts.

(2) Install fan module mounting bolts (Fig. 70) and torque to 16 N·m (140 in. lbs.)

(3) Connect fan module connector (Fig. 70).

(4) Install upper hose to radiator inlet and install clamp.

(5) Connect upper hose coolant switch connector (Fig. 69).

(6) Fill cooling system. (Refer to Filling Cooling System in this Group for the correct procedure.)

(7) Connect battery negative cable.

(8) Start engine and check for leaks. Check cooling fan for proper operation.

VISCOUS FAN DRIVE**REMOVAL/INSTALLATION**

Refer to Cooling System Fan removal and installation procedures of the viscous fan drive unit procedures.

Viscous Fan Drive Fluid Pump Out Requirement:

After installing a **NEW** viscous fan drive, bring the engine speed up to approximately 2000 rpm and hold for approximately two minutes. This will ensure proper fluid distribution within the drive.

CLEANING AND INSPECTION**RADIATOR CAP—INSPECTION**

Visually inspect the pressure valve gasket on the cap. Replace cap if the gasket is swollen, torn or worn. Inspect the area around radiator filler neck for white deposits that indicate a leaking cap.

COOLING SYSTEM

CAUTION: The cooling system normally operates at 97 to 124 kPa (14 to 18 psi) pressure. Exceeding this pressure may damage the radiator or hoses.

CLEANING

Drain cooling system and refill with water. Run engine with radiator cap installed until upper radiator hose is hot. Stop engine and drain water from system. If water is dirty, fill system with water, run engine and drain system. Repeat until water drains clean.

RADIATOR—CLEANING

The radiator and air conditioning fins should be cleaned when an accumulation of bugs, leaves etc. has occurred. Clean radiator fins are necessary for good heat transfer. With the engine cold, apply cold water and compressed air to the back (engine side) of

CLEANING AND INSPECTION (Continued)

the radiator to flush the radiator and/or A/C condenser of debris.

VISCOUS FAN—INSPECTION

The fan blades cannot be repaired. If the fan is damaged, it must be replaced. Inspect the fan blades as follows:

Lay fan blade assembly on a flat surface with leading edge facing down. With tip of blade touching flat surface, replace fan if clearance between opposite blade and surface is greater than 2.0 mm (.090 inch). Rocking motion of opposite blades should not exceed 2.0 mm (.090 inch). Test all blades in this manner.

WARNING: IF FAN IS NOT WITHIN SPECIFICATIONS, DO NOT ATTEMPT TO BEND OR STRAIGHTEN FAN.

Inspect fan assembly for cracks, bends, loose rivets or broken welds. Replace fan if any damage is found.

CAUTION: If the fan blade assembly is replaced because of mechanical damage, the water pump and viscous fan drive should also be inspected. These components could have been damaged due to excessive vibration.

WATER PUMP—INSPECTION

Replace water pump assembly if it has any of the following conditions:

- The body is cracked or damaged
- Water leaks from shaft seal. This is evident by traces of coolant below vent hole
- Loose or rough turning bearing. Also inspect viscous fan drive
- Impeller rubs either the pump body or timing chain case/cover

COOLING SYSTEM HOSES—INSPECTION

Inspect the hoses at regular intervals. Replace hoses that are cracked, feel brittle when squeezed, or swell excessively when the system is pressurized.

For all vehicles: In areas where specific routing clamps are not provided, be sure that hoses are positioned with sufficient clearance. Check clearance

from exhaust manifolds and pipe, fan blades, drive belts and sway bars. Improperly positioned hoses can be damaged, resulting in coolant loss and engine overheating.

Ordinary worm gear type hose clamps (when equipped) can be removed with a straight screwdriver or a hex socket. **To prevent damage to hoses or clamps, the hose clamps should be tightened to 4 N·m (34 in. lbs.) torque. Do not over tighten hose clamps.**

When performing a hose inspection, inspect the radiator lower hose for proper position and condition of the internal spring.

SPECIFICATIONS

COOLING SYSTEM CAPACITIES

ENGINE	CAPACITY*
4.0L	11.4L (12.0 QUARTS)
5.2L/5.9L	14.1L (14.9 QUARTS)

* Includes coolant recovery bottle capacity

ACCESSORY DRIVE BELT TENSION

4.0L Engine

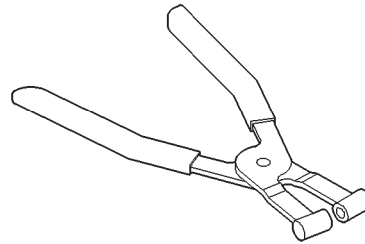
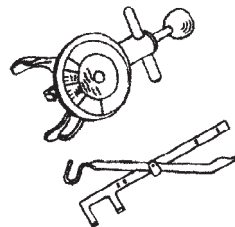
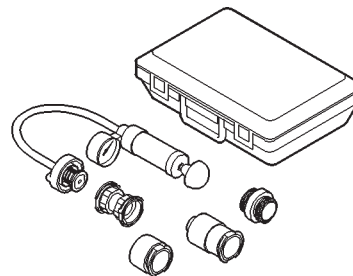
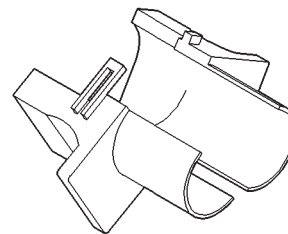
BELT	TENSION
NEW ACCESSORY DRIVE BELT*	800-900 N (180-200 lbs.)
USED ACCESSORY DRIVE BELT	623-712 N (140-160 lbs.)
*Belt is considered new if it has been used for 15 minutes or less	
Specifications for use with a belt tension gauge. Refer to operating instructions supplied with gauge.	

5.2L/5.9L Engine

Do not attempt to check belt tension with a tension gauge. System is equipped with an automatic tensioner. Refer to Automatic Belt Tensioner if Group 7, Cooling System

SPECIFICATIONS (Continued)**TORQUE SPECIFICATIONS**

DESCRIPTION	TORQUE
Automatic Belt Tensioner to Mounting Bracket (5.2/5.9L)	
Bolts67 N·m (50 ft. lbs.)
Automatic Belt Tensioner to Block (5.2/5.9L)	
Bolts41 N·m (30 ft. lbs.)
Automatic Belt Tensioner Pulley (5.2/5.9L)	
Bolt61 N·m (45 ft. lbs.)
Belt Tensioner Bracket to Block (4.0L)	
Bolts47 N·m (35 ft. lbs.)
Belt Idler Pulley (4.0L)	
Fixed Pulley Bolt57 N·m (42 ft. lbs.)
Belt Tensioner Pulley (4.0L)	
Bolt57 N·m (42 ft. lbs.)
Block Heater (4.0L)	
Bolt4 N·m (32 in. lbs.)
Block Heater (5.2/5.9L)	
Bolt2 N·m (17 in. lbs.)
Fan Blade Assy. to Viscous Drive (4.0L)	
Bolts23 N·m (200 in. lbs.)
Fan/Drive Assy. to Water Pump (4.0L)	
Nuts23 N·m (200 in. lbs.)
Fan Module to Radiator Support (5.9L)	
Bolts16 N·m (140 in. lbs.)
Generator Mounting (4.0L)	
Bolts57 N·m (42 ft. lbs.)
Radiator Upper Isolator to Crossmember	
Nuts3 N·m (20 in. lbs.)
Radiator Upper Isolator to Radiator	
Nuts4 N·m (36 in. lbs.)
Radiator Brace	
Bolts10 N·m (90 in. lbs.)
Thermostat Housing	
Bolts22 N·m (16 ft. lbs.)
Upper Radiator Crossmember to Body	
Bolts10 N·m (90 in. lbs.)
Water Pump (4.0L)	
Bolts30 N·m (22 ft. lbs.)
Water Pump (5.2/5.9L)	
Bolts40 N·m (30 ft. lbs.)
Water Pump Pulley (5.2/5.9L)	
Bolts27 N·m (20 ft. lbs.)

SPECIAL TOOLS**COOLING***Hose Clamp Pliers—6094**Belt Tension Gauge—C-4162**Cooling System Pressure Tester—7700-A**Quick Disconnect Tool—6935*

COOLING SYSTEM

CONTENTS

	page		page
GENERAL INFORMATION			
COOLANT TANK	3	COOLANT REPLACEMENT	18
COOLANT	4	DRAINING COOLING SYSTEM	15
COOLING SYSTEM	1	REFILLING COOLING SYSTEM	17
ENGINE ACCESSORY DRIVE BELTS	2	REMOVAL AND INSTALLATION	
LOW COOLANT LEVEL SENSOR	4	AUTOMATIC BELT TENSIONER	21
RADIATOR	2	DRIVE BELT	21
WATER PUMP	3	FAN BLADE REMOVAL	19
DESCRIPTION AND OPERATION			
AUTOMATIC BELT TENSIONER	7	RADIATOR	18
BELT TENSION	7	THERMOSTAT	20
COOLANT PERFORMANCE	5	VISCOUS FAN DRIVE	20
COOLING SYSTEM HOSES	5	WATER PUMP	21
PRESSURE/VENT CAP	4	CLEANING AND INSPECTION	
THERMOSTAT	4	COOLING SYSTEM CLEANING/REVERSE	
VISCOUS FAN DRIVE	6	FLUSHING	24
DIAGNOSIS AND TESTING			
BELT DIAGNOSIS	15	FAN BLADE	24
LOW COOLANT LEVEL- AERATION	15	RADIATOR CLEANING	24
PRELIMINARY CHECKS	7	WATER PUMP	24
RADIATOR COOLANT FLOW CHECK	8	ADJUSTMENTS	
TESTING COOLING SYSTEM FOR LEAKS ...	14	DRIVE BELT TENSION	25
THERMOSTAT	8	SPECIFICATIONS	
VISCOUS FAN DRIVE	8	COOLING SYSTEM CAPACITY	25
SERVICE PROCEDURES			
COOLANT LEVEL CHECK	15	THERMOSTAT	25
		TORQUE SPECIFICATIONS	25

GENERAL INFORMATION

COOLING SYSTEM

The cooling system regulates engine operating temperature. It allows the engine to reach normal operating temperature as quickly as possible, maintains normal operating temperature and prevents overheating.

The cooling system also provides a means of heating the passenger compartment. The cooling system is pressurized and uses a centrifugal water pump to circulate coolant throughout the system. A water manifold collects coolant from the cylinder heads. A separate and remotely mounted, pressurized coolant tank using a pressure/vent cap is used.

COOLING SYSTEM COMPONENTS

The cooling system consists of:

- A brass-core radiator with plastic side tanks
- A radiator mounted fill vent valve
- A separate pressurized coolant tank
- A cam type pressure/vent cap mounted to the coolant tank
- Cooling fan (mechanical)
- Thermal viscous fan drive
- Fan shroud
- Thermostat
- Coolant
- Low coolant level sensor
- Low coolant warning lamp
- Coolant temperature gauge
- Water pump
- Hoses and hose clamps

GENERAL INFORMATION (Continued)**COOLANT ROUTING**

For cooling system flow routing, refer to (Fig. 1)

RADIATOR

The radiator used with the 2.5L diesel is constructed of a horizontal cross-flow brass core with plastic side tanks.

CAUTION: Plastic tanks, while stronger than brass, are subject to damage by impact, such as wrenches.

If the plastic tank has been damaged, the tank and/or gaskets are available for service repair. Tank replacement should be done by qualified personal with proper equipment.

ENGINE ACCESSORY DRIVE BELTS

The accessory drive components are operated by a single, crankshaft driven, serpentine drive belt. Initial belt adjustment is done with an adjustable tensioner pulley. After the initial adjustment is performed, an automatic belt tensioner is used to maintain correct belt tension at all times.

CAUTION: When installing a serpentine accessory drive belt, the belt **MUST** be routed correctly. If not, the engine may overheat due to water pump rotating in wrong direction. Refer to the engine Belt Schematic in Specification section at the end of this group for the correct belt routing.

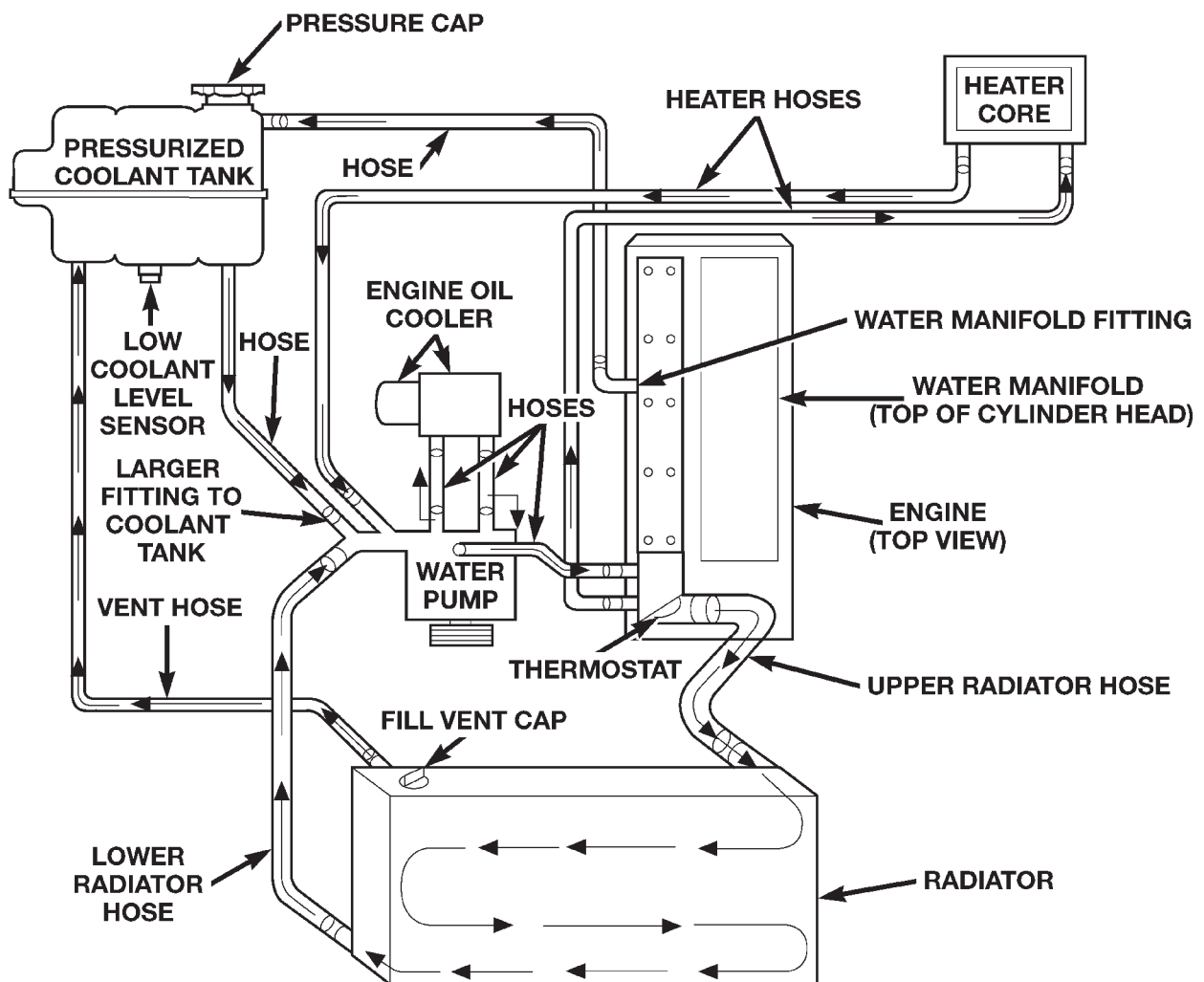


Fig. 1 Coolant Flow—2.5L Diesel Engine—Typical

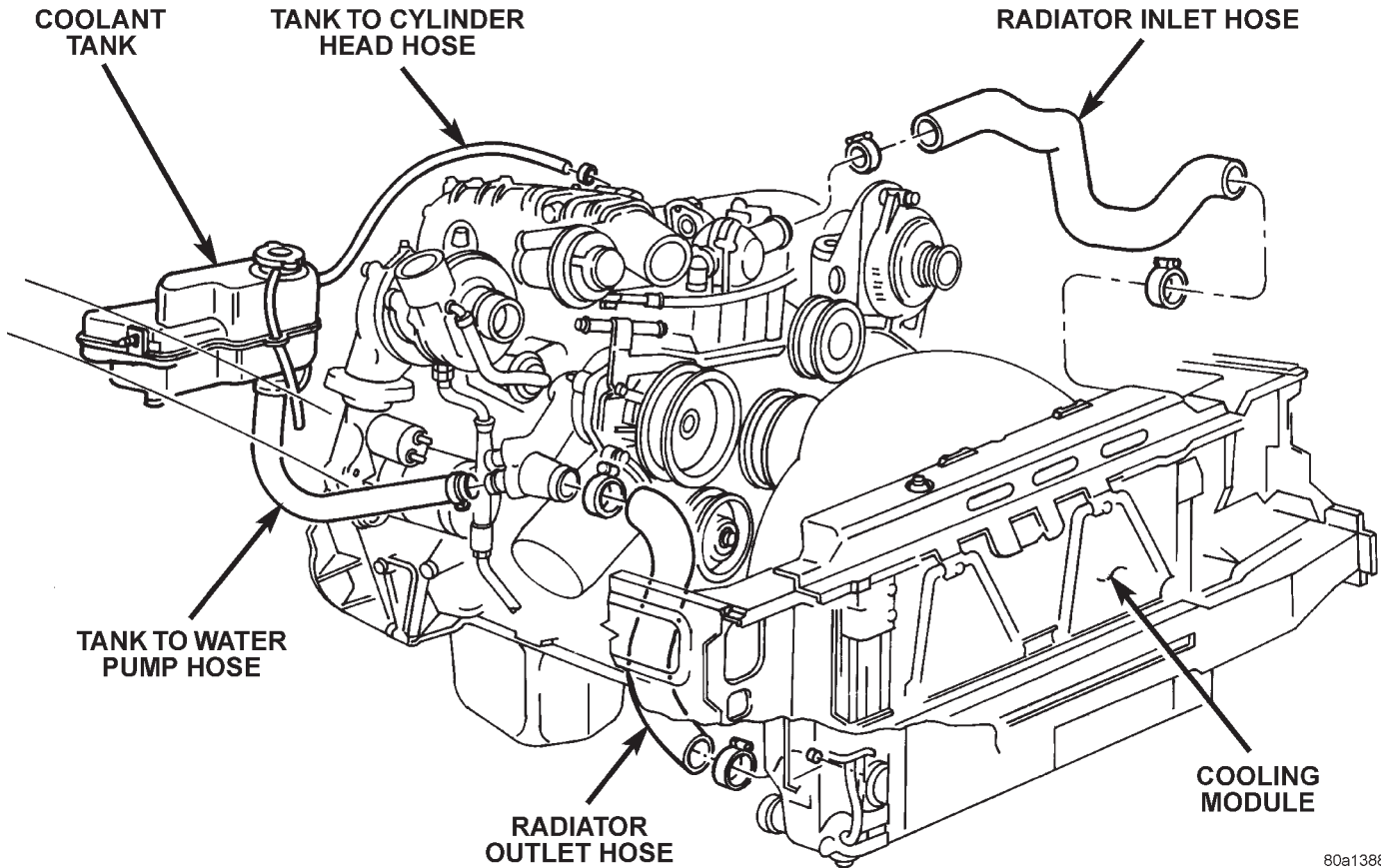
GENERAL INFORMATION (Continued)

Fig. 2 Coolant Tank and Radiator Hoses

COOLANT TANK

A pressurized, plastic coolant tank is used with the cooling system. This separate tank should be considered part of the radiator. The tank is located at the right-rear side of the engine compartment and is mounted as the highest point of the cooling system. This will allow any air or vapor exceeding the pressure/vent cap rating to escape through the cap. Coolant will flow through the tank at all times during engine operation whether the engine is cold or at normal operating temperature. The coolant tank is equipped with a cam type pressure/vent cap. Refer to Pressure/Vent Cap for additional information.

A separate coolant reserve/overflow tank is not used with this system.

The low coolant level sensor is located on the bottom of the tank (Fig. 2).

WATER PUMP

A centrifugal water pump circulates coolant through the water jackets, passages, water manifold, radiator core, pressurized coolant tank, cooling system hoses and heater core. The pump is driven from the engine crankshaft by a drive belt. The water pump is bolted to the water pump adapter (Fig. 3). The water pump adapter is bolted to the engine.

The water pump impeller is pressed onto the rear of a shaft that rotates in bearings pressed into the housing. The bottom of the housing is equipped with a small vent tube (Fig. 3) to allow seepage to escape. A drain hose is attached to this tube. The water pump seals are lubricated by the antifreeze in the coolant mixture. No additional lubrication is necessary.

GENERAL INFORMATION (Continued)

6A rubber o-ring (instead of a gasket) is used as a seal between the water pump and the water pump adapter (Fig. 3).

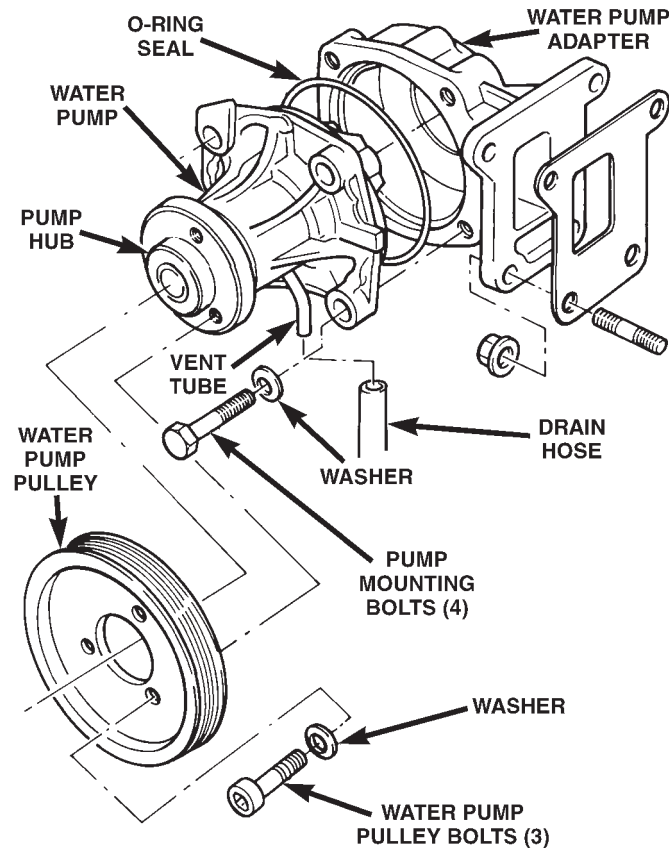


Fig. 3 Water Pump— Typical

80a0c4e0

A quick test to determine if the pump is working is to check if the heater warms properly. A defective water pump will not be able to circulate heated coolant through the long heater hose to the heater core.

COOLANT

The cooling system is designed around the coolant. Coolant flows through the engine water jackets and water manifold absorbing heat produced during engine operation. The coolant carries heat to the radiator and heater core. Here it is transferred to the ambient air passing through the radiator and heater core fins.

LOW COOLANT LEVEL SENSOR

The low coolant level sensor checks for low coolant level in the coolant tank. A signal will be sent from this sensor to the powertrain control module (PCM). When the PCM determines low coolant level, the instrument panel mounted low coolant level warning lamp will be illuminated. The sensor is located on the bottom of the coolant tank. For information, refer to Group 8E, Instrument Panel and Gauges.

If this lamp is illuminated, it indicates the need for service.

DESCRIPTION AND OPERATION

THERMOSTAT

A pellet-type thermostat controls the operating temperature of the engine by controlling the amount of coolant flow to the radiator. The thermostat starts to open at 80°C (176°F). Above this temperature, coolant is allowed to flow to the radiator. This provides quick engine warmup and overall temperature control.

The same thermostat is used for winter and summer seasons. An engine should not be operated without a thermostat, except for servicing or testing. Operating without a thermostat causes other problems. These are: longer engine warmup time, unreliable warmup performance, increased exhaust emissions and crankcase condensation. This condensation can result in sludge formation.

CAUTION: Do not operate an engine without a thermostat, except for servicing or testing.

PRESSURE/VENT CAP

The pressure/vent cap is cam type cap. This cap releases excess pressure at some point within a range of 90 - 117 kPa (13 - 17 psi). The actual pressure relief point (in pounds) is labeled on top of the cap.

The cooling system will operate at pressures slightly above atmospheric pressure. This results in a higher coolant boiling point allowing increased radiator cooling capacity. The cap contains a spring-loaded pressure relief valve. This valve opens when system pressure reaches approximately 103 kPa (15 psi).

When the engine is cooling down, vacuum is formed within the cooling system. To prevent collapse of the radiator and coolant hoses from this vacuum, a vacuum valve is used within the cap. This valve prevents excessive pressure differences from occurring between the closed cooling system and the atmosphere. If the vacuum valve is stuck shut, the radiator and/or cooling system hoses will collapse on cool-down.

NOTE: Do not use any type of tool when tightening the cap. Hand tighten only (approximately 5 N·m or 44 in. lbs.) torque.

DESCRIPTION AND OPERATION (Continued)

COOLANT PERFORMANCE

ETHYLENE-GLYCOL MIXTURES

The required ethylene-glycol (antifreeze) and water mixture depends upon the climate and vehicle operating conditions. The recommended mixture of 50/50 ethylene-glycol and water will provide protection against freezing to -37 deg. C (-35 deg. F). The anti-freeze concentration **must always** be a minimum of 44 percent, year-round in all climates. **If percentage is lower than 44 percent, engine parts may be eroded by cavitation, and cooling system components may be severely damaged by corrosion.** Maximum protection against freezing is provided with a 68 percent antifreeze concentration, which prevents freezing down to -67.7 deg. C (-90 deg. F). A higher percentage will freeze at a warmer temperature. Also, a higher percentage of antifreeze can cause the engine to overheat because the specific heat of antifreeze is lower than that of water.

100 Percent Ethylene-Glycol—Should Not Be Used in Chrysler Vehicles

Use of 100 percent ethylene-glycol will cause formation of additive deposits in the system, as the corrosion inhibitive additives in ethylene-glycol require the presence of water to dissolve. The deposits act as insulation, causing temperatures to rise to as high as 149 deg. C (300 deg. F). This temperature is hot enough to melt plastic and soften solder. The increased temperature can result in engine detonation. In addition, 100 percent ethylene-glycol freezes at 22 deg. C (-8 deg. F).

Propylene-glycol Formulations—Should Not Be Used in Chrysler Vehicles

Propylene-glycol formulations do not meet Chrysler coolant specifications. It's overall effective temperature range is smaller than that of ethylene-glycol. The freeze point of 50/50 propylene-glycol and water is -32 deg. C (-26 deg. F), 5 deg. C higher than ethylene-glycol's freeze point. The boiling point (protection against summer boil-over) of propylene-glycol is 125 deg. C (257 deg. F) at 96.5 kPa (14 psi), compared to 128 deg. C (263 deg. F) for ethylene-glycol. Use of propylene-glycol can result in boil-over or freeze-up in Chrysler vehicles, which are designed for ethylene-glycol. Propylene glycol also has poorer heat transfer characteristics than ethylene glycol. This can increase cylinder head temperatures under certain conditions.

Propylene-glycol/Ethylene-glycol Mixtures—Should Not Be Used in Chrysler Vehicles

Propylene-glycol/ethylene-glycol Mixtures can cause the destabilization of various corrosion inhibitors, causing damage to the various cooling system components. Also, once ethylene-glycol and propylene-glycol based coolants are mixed in the vehicle, conventional methods of determining freeze point will not be accurate. Both the refractive index and specific gravity differ between ethylene glycol and propylene glycol.

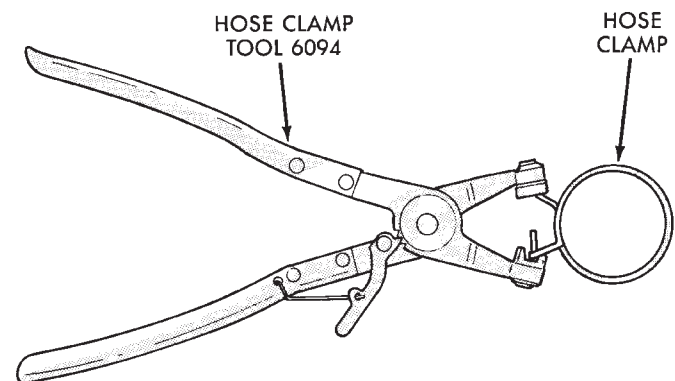
CAUTION: Richer antifreeze mixtures cannot be measured with normal field equipment and can cause problems associated with 100 percent ethylene-glycol.

COOLING SYSTEM HOSES

Rubber hoses route coolant to and from the radiator, water manifold and heater core. Models equipped with air conditioning have a heater water control (shut-off) valve. This is located in-line with the heater core inlet and outlet hoses. It controls coolant flow to the heater core when the air conditioning system is in operation.

Radiator lower hoses are spring-reinforced to prevent collapse from water pump suction at moderate and high engine speeds.

WARNING: CONSTANT TENSION HOSE CLAMPS ARE USED ON MOST COOLING SYSTEM HOSES. WHEN REMOVING OR INSTALLING, USE ONLY TOOLS DESIGNED FOR SERVICING THIS TYPE OF CLAMP (Fig. 4). ALWAYS WEAR SAFETY GLASSES WHEN SERVICING CONSTANT TENSION CLAMPS.



J9207-36

Fig. 4 Hose Clamp Tool

DESCRIPTION AND OPERATION (Continued)

CAUTION: A number or letter is stamped into the tongue of constant tension clamps (Fig. 5). If replacement is necessary, use only an original equipment clamp with matching number or letter.

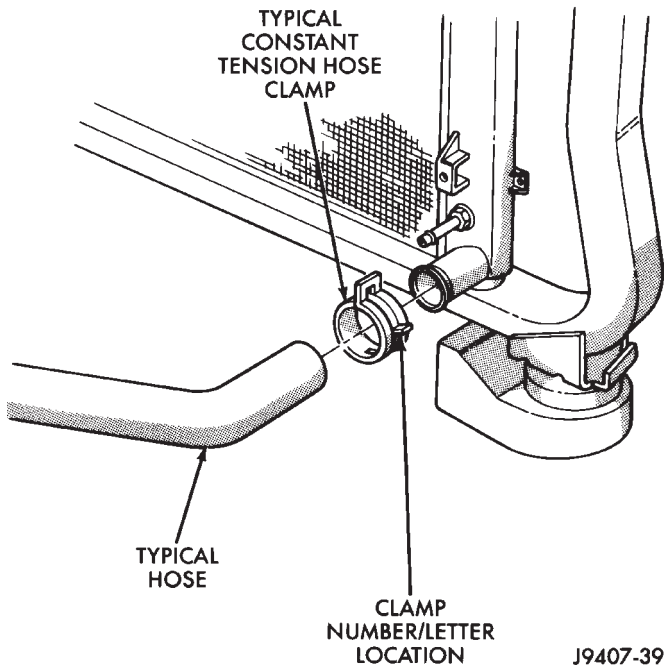


Fig. 5 Clamp Number/Letter Location

Inspect the hoses at regular intervals. Replace hoses that are cracked, feel brittle when squeezed, or swell excessively when the system is pressurized.

For all vehicles: In areas where specific routing clamps are not provided, be sure that hoses are positioned with sufficient clearance. Check clearance from exhaust manifolds and pipe, fan blades, drive belts and sway bars. Improperly positioned hoses can be damaged, resulting in coolant loss and engine overheating.

Ordinary worm gear type hose clamps (when equipped) can be removed with a straight screwdriver or a hex socket. **To prevent damage to hoses or clamps, the hose clamps should be tightened to 4 N·m (34 in. lbs.) torque. Do not over tighten hose clamps.**

When performing a hose inspection, inspect the radiator lower hose for proper position and condition of the internal spring.

VISCOUS FAN DRIVE

The thermal viscous fan drive (Fig. 6) is a silicone-fluid-filled coupling. It connects the fan blade assembly to the fan pulley. The coupling allows the fan to be driven in a normal manner. This is done at low engine speeds while limiting the top speed of the fan to a predetermined maximum level at higher engine speeds. A bimetallic spring coil is located on the front face. This spring coil reacts to the temperature of the

radiator discharge air. It engages the viscous fan drive for higher fan speed if the air temperature from the radiator rises above a certain point. Until additional engine cooling is necessary, the fan will remain at a reduced rpm regardless of engine speed.

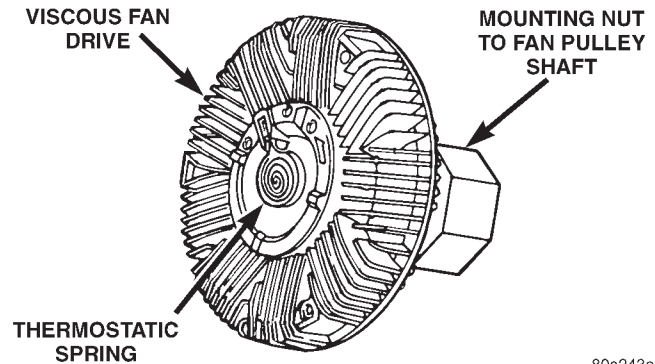


Fig. 6 Viscous Fan Drive

The viscous fan drive will only engage when sufficient heat is present. This is when the air flowing through the radiator core causes a reaction from the bimetallic coil. It then increases fan speed to provide the necessary additional engine cooling.

Once the engine has cooled, the radiator discharge temperature will drop. The bimetallic coil again reacts and the fan speed is reduced to the previous disengaged speed.

CAUTION: Some engines equipped with serpentine drive belts have reverse rotating fans and viscous fan drives. They are marked with the word **REVERSE** to designate their usage. Installation of the wrong fan or viscous fan drive can result in engine overheating.

NOISE

NOTE: It is normal for fan noise to be louder (roaring) when:

- The underhood temperature is above the engagement point for the viscous drive coupling. This may occur when ambient (outside air temperature) is very high.
- Engine loads and temperatures are high such as when towing a trailer.
- Cool silicone fluid within the fan drive unit is being redistributed back to its normal disengaged (warm) position. This can occur during the first 15 seconds to one minute after engine start-up on a cold engine.

DESCRIPTION AND OPERATION (Continued)

LEAKS

Viscous fan drive operation is not affected by small oil stains near the drive bearing. If leakage appears excessive, replace the fan drive unit.

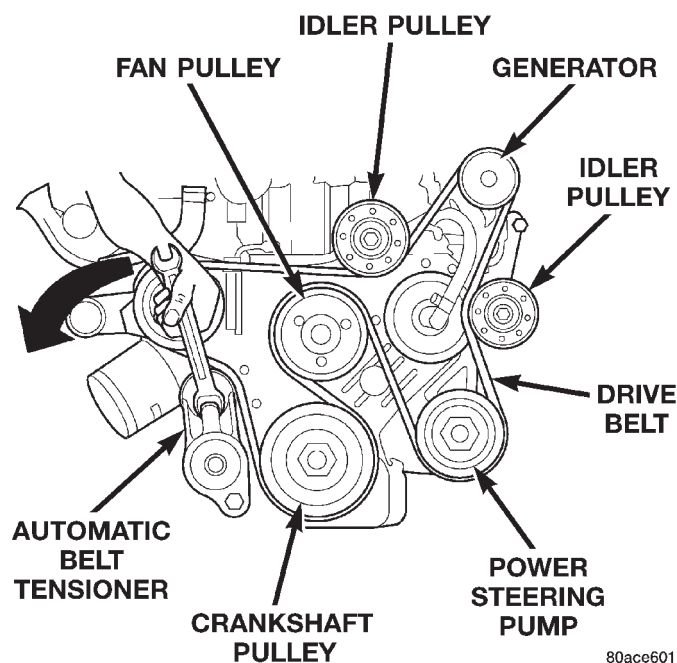
BELT TENSION

Correct accessory drive belt tension is required to be sure of optimum performance of belt driven engine accessories. If specified tension is not maintained, belt slippage may cause; engine overheating, lack of power steering assist, loss of air conditioning capacity, reduced generator output rate and greatly reduced belt life.

Initial belt adjustment is done with a adjustable tensioner pulley. After the initial adjustment is performed, an automatic belt tensioner is used to maintain correct belt tension at all times. Do not attempt to check belt tension with a belt tension gauge on vehicles equipped with an automatic belt tensioner. Refer to Automatic Belt Tensioner in this group.

AUTOMATIC BELT TENSIONER

Drive belt tension is controlled by a spring loaded automatic belt tensioner located below and to the front of the engine oil filter (Fig. 7). This tensioner is connected to a pivot bracket and a pulley (Fig. 7). The pivot bracket rotates on a pivot pin attached to the engine. Special machined washers with rubber o-rings (Fig. 7) are used at each side of the pivot bracket to help keep dirt and water away from the pivot pin.



80aco601

Fig. 7 Automatic Belt Tensioner Assembly

If a defective belt tensioner is suspected, a check of this pivot bracket and pivot pin should be made. Corrosion may have formed at the pin and may cause the pivot bracket to stick. Belt slippage will result.

WARNING: BECAUSE OF HIGH SPRING PRESSURE, DO NOT ATTEMPT TO DISASSEMBLE THE AUTOMATIC BELT TENSIONER. UNIT IS SERVICED AS AN ASSEMBLY.

DIAGNOSIS AND TESTING

PRELIMINARY CHECKS

ENGINE COOLING SYSTEM OVERHEATING

Establish what driving conditions caused the complaint. Abnormal loads on the cooling system such as the following may be the cause:

(1) PROLONGED IDLE, VERY HIGH AMBIENT TEMPERATURE, SLIGHT TAIL WIND AT IDLE, SLOW TRAFFIC, TRAFFIC JAMS, HIGH SPEED OR STEEP GRADES.

Driving techniques that avoid overheating are:

- Idle with A/C off when temperature gauge is at end of normal range.
- Increasing engine speed for more air flow is recommended.

(2) TRAILER TOWING:

Consult Trailer Towing section of owners manual. Do not exceed limits.

(3) RECENT SERVICE OR ACCIDENT REPAIR:

Determine if any recent service has been performed on vehicle that may effect cooling system. This may be:

- Engine adjustments (incorrect timing)
- Slipping engine accessory drive belt
- Brakes (possibly dragging)
- Changed parts (incorrect water pump)
- Reconditioned radiator or cooling system refilling (possibly under filled or air trapped in system).

NOTE: If investigation reveals none of the previous items as a cause for an engine overheating complaint, refer to following Cooling System Diagnosis charts.

These charts are to be used as a quick-reference only. Refer to the group text for information.

DIAGNOSIS AND TESTING (Continued)**COOLING SYSTEM DIAGNOSIS—DIESEL ENGINE****THERMOSTAT****DIAGNOSIS**

Diesel engines, due to their inherent efficiency are slower to warm up than gasoline powered engines, and will operate at lower temperatures when the vehicle is unloaded. Because of this, lower temperature gauge readings for diesel versus gasoline engines may, at times be normal.

Typically, complaints of low engine coolant temperature are observed as low heater output when combined with cool or cold outside temperatures.

To help promote faster engine warm-up, an electric engine block heater must be used with cool or cold outside temperatures. This will help keep the engine coolant warm when the vehicle is parked. Use the block heater if the outside temperature is below 4°C (40°F). **Do not use the block heater if the outside temperature is above 4°C (40°F).**

TESTING

NOTE: The DRB scan tool cannot be used to monitor engine coolant temperature on the diesel engine.

(1) To determine if the thermostat is defective, it must be removed from the vehicle. Refer to Thermostats for removal and installation procedures.

(2) After the thermostat has been removed, examine the thermostat and inside of thermostat housing for contaminants. If contaminants are found, the thermostat may already be in a “stuck open” position. Flush the cooling system before replacing thermostat. Refer to Cooling System Cleaning/Reverse Flushing in this group for additional information.

(3) Place the thermostat into a container filled with water.

(4) Place the container on a hot plate or other suitable heating device.

(5) Place a commercially available radiator thermometer into the water.

(6) Apply heat to the water while observing the thermostat and thermometer.

(7) When the water temperature reaches 80°C (176°F) the thermostat should start to open (valve will start to move). If the valve starts to move before this temperature is reached, it is opening too early. Replace thermostat. The thermostat should be fully open (valve will stop moving) at approximately 89°C (192°F). If the valve is still moving after the water temperature reaches this temperature, it is opening too late. Replace thermostat.

(8) If the valve refuses to move at any time, replace thermostat.

VISCOUS FAN DRIVE**TESTING**

If the fan assembly free-wheels without drag (the fan blades will revolve more than five turns when spun by hand), replace the fan drive. This spin test must be performed when the engine is cool.

The cooling system must be in good condition. This is checked prior to performing the following test. It also will ensure against excessively high coolant temperature.

WARNING: BE SURE OF ADEQUATE FAN BLADE CLEARANCE BEFORE DRILLING.

(1) Drill a 3.12-mm (1/8-in) diameter hole in the top center of the fan shroud.

(2) Obtain a dial thermometer with an 8 inch stem (or equivalent). It should have a range of -18° to 105°C (0° to 220° F). Insert thermometer through the hole in the shroud. Be sure that there is adequate clearance from the fan blades.

(3) Block the air flow through the radiator. Secure a sheet of plastic in front of the radiator (or air conditioner condenser). Use tape at the top to secure the plastic and be sure that the air flow is blocked.

(4) Be sure that the air conditioner (if equipped) is turned off.

WARNING: USE EXTREME CAUTION WHEN THE ENGINE IS OPERATING. DO NOT STAND IN A DIRECT LINE WITH THE FAN. DO NOT PUT YOUR HANDS NEAR THE PULLEYS, BELTS OR FAN. DO NOT WEAR LOOSE CLOTHING.

(5) Start the engine and operate at 2400 rpm. Within ten minutes the air temperature (indicated on the dial thermometer) should be up to 93° C (200° F). Fan drive **engagement** should have started to occur at between 82° to 91° C (180° to 195° F). Engagement is distinguishable by a definite **increase** in fan flow noise (roaring).

(6) When the air temperature reaches 93° C (200° F), remove the plastic sheet. Fan drive **disengagement** should have started to occur at between 57° to 79° C (135° to 175° F). A definite **decrease** of fan flow noise (roaring) should be noticed. If not, replace the defective viscous fan drive unit.

RADIATOR COOLANT FLOW CHECK

There is coolant flow all of the time through the coolant tank (bottle) before and after the thermostat opens. If you remove the vent valve and insert a temperature gauge through the opening, coolant will spill out of the system and the engine will not be filled with coolant up to the heads.

CAUTION: Major damage could happen if you run the engine in this condition.

DIAGNOSIS AND TESTING (Continued)

CONDITION	POSSIBLE CAUSES	CORRECTION
TEMPERATURE GAUGE READS LOW	<ol style="list-style-type: none"> 1. Diesel engines, due to their inherent efficiency are slower to warm up than gasoline powered engines, and will operate at lower temperatures when the vehicle is unloaded. 2. Is the temperature gauge connected to the temperature gauge coolant sensor on the engine? 3. Is the temperature gauge operating OK? 4. Coolant level low in cold ambient temperatures accompanied with poor heater performance. 5. Improper operation of internal heater doors or heater controls. 	<ol style="list-style-type: none"> 1. The low gauge reading may be normal. Refer to thermostats in the manual text for information. See Thermostat Diagnosis - Diesel Engine. 2. Check, the engine temperature sensor connector in the engine compartment. Refer to Group 8E. Repair as necessary. 3. Check gauge operation. Refer to Group 8E. Repair as necessary. 4. Check coolant level in the coolant tank. Inspect system for leaks. Repair leaks as necessary. Refer to the Coolant section of the manual text for WARNINGS and precautions before removing the pressure cap. 5. Inspect heater and repair as necessary. Refer to Group 24, Heating and Air Conditioning for procedures.
TEMPERATURE GAUGE READS HIGH. COOLANT MAY OR MAY NOT BE LOST OR LEAKING FROM COOLING SYSTEM	<ol style="list-style-type: none"> 1. Trailer is being towed, a steep hill is being climbed, vehicle is operated in slow moving traffic, or engine is being idled with very high ambient (outside) temperatures and the air conditioning is on. Higher altitudes could aggravate these conditions. 2. Is temperature gauge reading correctly? 3. Coolant low in coolant tank and radiator? 4. Pressure cap not installed tightly. If cap is loose, boiling point of coolant will be lowered. Also refer to the following step 5. 5. Poor seals at pressure/vent cap. 6. Freeze point of antifreeze not correct. Mixture may be too rich. 	<ol style="list-style-type: none"> 1. This may be a temporary condition and repair is not necessary. Turn off the air conditioning and attempt to drive the vehicle without any of the previous conditions. Observe the temperature gauge. The gauge should return to the normal range. If the gauge does not return to normal range, determine the cause for overheating and repair. Refer to POSSIBLE CAUSES (numbers 2 through 16). 2. Check gauge. Refer to Group 8E. Repair as necessary. 3. Check for coolant leaks and repair as necessary. Refer to Testing Cooling System For Leaks in this group. 4. Tighten cap. 5. (a) Check condition of cap and cap seals. Refer to Pressure/Vent Cap. Replace cap if necessary. (b) Check condition of coolant tank filler neck. Make sure it does not leak pressure. 6. Check antifreeze. Refer to Coolant section of this group. Adjust antifreeze-to-water ratio as required.

DIAGNOSIS AND TESTING (Continued)

CONDITION	POSSIBLE CAUSES	CORRECTION
TEMPERATURE GAUGE READS HIGH. COOLANT MAY OR MAY NOT BE LOST OR LEAKING FROM COOLING SYSTEM - CONT.	<ol style="list-style-type: none"> 7. Coolant not flowing through system. 8. Radiator or A/C condenser fins are dirty or clogged. 9. Radiator core is corroded or plugged. 10. Aftermarket A/C installed without proper A/C condenser. 11. Dragging brakes. 12. Non-factory bug screen is being used reducing airflow. 13. Thermostat partially or completely shut. This is more prevalent on high mileage vehicles. 14. Thermal viscous fan drive not operating properly. 15. Cylinder head gasket leaking. 16. Heater core leaking. 	<ol style="list-style-type: none"> 7. Check for coolant flow in coolant tank with engine warm and thermostat open. Coolant should be observed flowing through tank. If flow is not observed, determine reason for lack of flow and repair as necessary. 8. Clean insects or debris. Refer to Radiator Cleaning in this group. 9. Have radiator re-cored or replaced. 10. Install proper A/C condenser. 11. Check and correct as necessary. Refer to Group 5, Brakes in the manual text. 12. Only a factory approved screen may be used. 13. Check thermostat operation and replace as necessary. Refer to Thermostats in this group. 14. Check fan drive operation and replace if necessary. Refer to Viscous Fan Drive in this group. 15. Check for cylinder head gasket leaks. Refer to Testing Cooling System For Leaks in this group. For repair, refer to Group 9, Engines. 16. Check heater core for leaks. Refer to Group 24, Heating and Air Conditioning. Repair as necessary.
TEMPERATURE GAUGE READING IS INCONSISTENT (FLUCTUATES, CYCLES OR IS ERRATIC)	<ol style="list-style-type: none"> 1. During cold weather operation, with the heater blower in the high position, the gauge reading may drop slightly. Fluctuation is also influenced by loads, outside temperature and extended idle time with diesel engines. 2. Temperature gauge or engine mounted gauge sensor defective or shorted. Also, corroded or loose wiring in this circuit. 3. Gauge reading rises when vehicle is brought to a stop after heavy use (engine still running). 4. Gauge reading high after re-starting a warmed-up (hot) engine. 5. Coolant level low in coolant tank (air will build up in the cooling system causing the thermostat to open late). 	<ol style="list-style-type: none"> 1. A normal condition. No correction is necessary. 2. Check operation of gauge and repair if necessary. Refer to Group 8E, Instrument Panel And Gauges. 3. A normal condition. No correction is necessary. Gauge reading should return to normal range after vehicle is driven. 4. A normal condition. No correction is necessary. The gauge should return to normal range after a few minutes of engine operation. 5. Check and correct coolant leaks. Refer to Testing Cooling System For Leaks in this group.

DIAGNOSIS AND TESTING (Continued)

CONDITION	POSSIBLE CAUSES	CORRECTION
TEMPERATURE GAUGE READING IS INCONSISTENT (FLUCTUATES, CYCLES OR IS ERRATIC), CONT'D.	<ol style="list-style-type: none"> 6. Cylinder head gasket leaking allowing exhaust gas to enter cooling system causing thermostat to open late. 7. Water pump impeller loose on shaft. 8. Loose accessory drive belt (water pump slipping). 9. Air leak on the suction side of water pump allows air to build up in cooling system causing thermostat to open late. 	<ol style="list-style-type: none"> 6. (a) Check for cylinder head gasket leaks with a commercially available Block Leak Tester. Repair as necessary. (b) Check for coolant in the engine oil. Inspect for white steam emitting from exhaust system. Repair as necessary. 7. Check water pump and replace as necessary. Refer to Water Pumps in this group. 8. Refer to Engine Accessory Drive Belts in this group. Check and correct as necessary. 9. Locate leak and repair as necessary.
PRESSURE CAP IS BLOWING OFF STEAM AND/OR COOLANT. TEMPERATURE GAUGE READING MAY BE ABOVE NORMAL BUT NOT HIGH. COOLANT LEVEL MAY BE HIGH IN COOLANT TANK	<ol style="list-style-type: none"> 1. Pressure relief valve in pressure/vent cap is defective. 2. Major head gasket leak or cracked cylinder head. 	<ol style="list-style-type: none"> 1. Check condition of pressure/vent cap and cap seals. Refer to Pressure/Vent Caps in this group. Replace cap as necessary. 2. Refer to Engine group and repair as necessary.
COOLANT LOSS TO THE GROUND WITHOUT PRES-SURE CAP BLOWOFF. GAUGE IS READING HIGH OR HOT	<ol style="list-style-type: none"> 1. Coolant leaks in radiator, cooling system hoses, water pump or engine. 	<ol style="list-style-type: none"> 1. Pressure test and repair as necessary. Refer to Testing Cooling System For Leaks in this group.
HOSE OR HOSES COLLAPSE WHEN ENGINE IS COOLING	<ol style="list-style-type: none"> 1. Vacuum created in cooling system on engine cool-down is not being relieved through pressure/vent cap. 	<ol style="list-style-type: none"> 1. Cap relief valve stuck. Refer to Pressure/Vent Cap in this group. Replace if necessary.
NOISY FAN	<ol style="list-style-type: none"> 1. Fan blades loose. 2. Fan blades striking a surrounding object. 3. Air obstructions at radiator or air conditioning condenser. 4. Thermal viscous fan drive has defective bearing. 5. A certain amount of fan noise (roaring) may be evident on models equipped with a thermal viscous fan drive. Some of this noise is normal. 	<ol style="list-style-type: none"> 1. Replace fan blade assembly. Refer to Cooling System Fans in this group. 2. Locate point of fan blade contact and repair as necessary. 3. Remove obstructions and/or clean debris or insects from radiator or A/C condenser. 4. Replace fan drive. Bearing is not serviceable. Refer to Viscous Fan Drive in this group. 5. Refer to Viscous Fan Drive in this group for an explanation of normal fan noise.

DIAGNOSIS AND TESTING (Continued)

CONDITION	POSSIBLE CAUSES	CORRECTION
INADEQUATE AIR CONDITIONER PERFORMANCE (COOLING SYSTEM SUSPECTED)	<ol style="list-style-type: none"> 1. Radiator and/or A/C condenser is restricted, obstructed or dirty (insects, leaves etc.). 2. Thermal viscous fan drive is free-wheeling. 3. Engine is overheating (heat may be transferred from radiator to A/C condenser. High underhood temperatures due to engine overheating may also transfer heat to A/C components). 4. The cooling system is equipped with air seals at the radiator and/or A/C condenser. If these seals are missing or damaged, not enough air flow will be pulled through the radiator and A/C condenser. 	<ol style="list-style-type: none"> 1. Remove restriction and/or clean as necessary. Refer to Radiator Cleaning in this group. 2. Refer to Viscous Fan Drive for diagnosis. Repair as necessary. 3. Correct overheating condition. Refer to text in Group 7, Cooling. 4. Check for missing or damaged air seals and repair as necessary.
INADEQUATE HEATER PERFORMANCE. MAY BE ACCOMPANIED BY LOW GAUGE READING	<ol style="list-style-type: none"> 1. Diesel engines, due to their inherent efficiency are slower to warm up than gasoline powered engines, and will operate at lower temperatures when the vehicle is unloaded. 2. Coolant level low. 3. Obstructions in heater hose fittings at engine. 4. Heater hose kinked. 5. Water pump is not pumping water to heater core. When the engine is fully warmed up, both heater hoses should be hot to the touch. If only one of the hoses is hot, the water pump may not be operating correctly. The accessory drive belt may also be slipping causing poor water pump operation. 	<ol style="list-style-type: none"> 1. The low gauge reading may be normal. Refer to Thermostats in the manual text for information. See Thermostat Diagnosis - Diesel Engine. 2. Refer to Testing Cooling System For Leaks in the manual text. Repair as necessary. 3. Remove heater hoses at both ends and check for obstructions. Repair as necessary. 4. Located kinked area and repair as necessary. 5. Refer to Water Pumps in this group. Repair as necessary. If a slipping belt is detected, refer to Engine Accessory Drive Belts in this group. Repair as necessary.

DIAGNOSIS AND TESTING (Continued)

CONDITION	POSSIBLE CAUSES	CORRECTION
HEAT ODOR	<ol style="list-style-type: none"> 1. Various heat shields are used at certain drive line components. One or more of these shields may be missing. 2. Is temperature gauge reading above the normal range? 3. Is cooling fan operating correctly? 4. Has undercoating been applied to any unnecessary component? 	<ol style="list-style-type: none"> 1. Locate missing shields and replace or repair as necessary. 2. Refer to the previous Temperature Gauge Reads High in these Diagnosis Charts. Repair as necessary. 3. Refer to Cooling System Fan in this group for diagnosis. Repair as necessary. 4. Clean undercoating as necessary.
STEAM IS COMING FROM FRONT OF VEHICLE NEAR GRILL AREA WHEN WEATHER IS WET, ENGINE IS WARMED UP AND RUNNING, AND VEHICLE IS STATIONARY. TEMPERATURE GAUGE IS IN NORMAL RANGE	<ol style="list-style-type: none"> 1. During wet weather, moisture (snow, ice or rain condensation) on the radiator will evaporate when the thermostat opens. This opening allows heated water into the radiator. When the moisture contacts the hot radiator, steam may be emitted. This usually occurs in cold weather with no fan or airflow to blow it away. 	<ol style="list-style-type: none"> 1. Occasional steam emitting from this area is normal. No repair is necessary.
COOLANT COLOR	<ol style="list-style-type: none"> 1. Coolant color is not necessarily an indication of adequate corrosion or temperature protection. Do not rely on coolant color for determining condition of coolant. 	<ol style="list-style-type: none"> 1. Refer to Coolant in this group for antifreeze tests. Adjust antifreeze-to-water ratio as necessary.
COOLANT LEVEL CHANGES IN COOLANT TANK. TEMPERATURE GAUGE IS IN NORMAL RANGE	<ol style="list-style-type: none"> 1. Level changes are to be expected as coolant volume fluctuates with engine temperature. If the level in the tank was between the HOT and COLD marks at normal engine operating temperature, the level should return to within that range after operation at elevated temperatures. 	<ol style="list-style-type: none"> 1. A normal condition. No repair is necessary.

DIAGNOSIS AND TESTING (Continued)**TESTING COOLING SYSTEM FOR LEAKS****ULTRAVIOLET LIGHT METHOD**

All Jeep™ models have a leak detection additive added to the cooling system before they leave the factory. The additive is highly visible under ultraviolet light (black light). If the factory original coolant has been drained, pour one ounce of additive into the cooling system. The additive is available through the parts department. Place the heater control unit in HEAT position. Start and operate the engine until the radiator upper hose is warm to the touch. Aim the commercially available black light tool at the components to be checked. If leaks are present, the black light will cause the additive to glow a bright green color.

The black light can be used along with a radiator pressure tester to determine if any external leaks exist (Fig. 8).

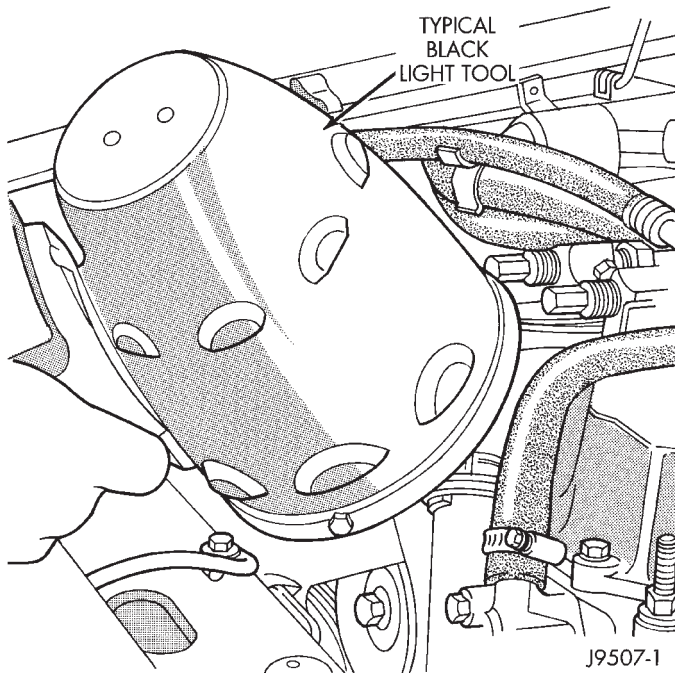


Fig. 8 Leak Detection Using Black Light—Typical PRESSURE TESTER METHOD

WARNING: HOT, PRESSURIZED COOLANT CAN CAUSE SERIOUS INJURY BY SCALDING. NEVER REMOVE THE PRESSURE/VENT CAP OR PRESSURE TESTER WHEN THE COOLING SYSTEM IS HOT OR UNDER PRESSURE!

Allow the engine to cool sufficiently so that the system is not under pressure and carefully remove the pressure/vent cap from the filler neck. Warm the engine with the pressure/vent cap off to normal operating temperature. With the engine turned off attach

the cooling system pressure tester and test the system as described below.

Recheck the system cold if the cause of coolant loss is not located during warm engine examination.

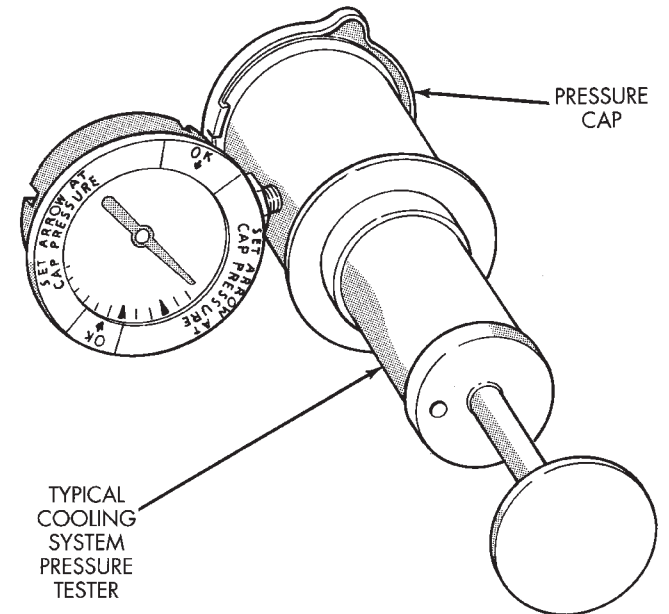


Fig. 9 Typical Cooling System Pressure Tester

Operate the tester pump to apply 103 kPa (15 psi) pressure to the system. If the hoses enlarge excessively or bulge while testing, replace as necessary. Observe the gauge pointer and determine the condition of the cooling system according to the following criteria:

- **Holds Steady:** If the pointer remains steady for two minutes, there are no serious coolant leaks in the system. However, there could be an internal leak that does not appear with normal system test pressure. Inspect for interior leakage or do the Internal Leakage Test. Do this if it is certain that coolant is being lost and no leaks can be detected.
- **Drops Slowly:** Shows a small leak or seepage is occurring. Examine all connections for seepage or slight leakage with a flashlight. Inspect the radiator, hoses, gasket edges and heater. Seal any small leak holes with a Sealer Lubricant or equivalent. Repair leak holes and reinspect the system with pressure applied.
- **Drops Quickly:** Shows that a serious leakage is occurring. Examine the system for serious external leakage. If no leaks are visible, inspect for internal leakage. Large radiator leak holes should be repaired by a reputable radiator repair shop.

DIAGNOSIS AND TESTING (Continued)

INTERNAL LEAKAGE INSPECTION

Remove the oil pan drain plug and drain a small amount of engine oil. Coolant, being heavier will drain first, or operate engine to churn oil, then examine dipstick for water globules. Operate the engine without the pressure/vent cap on the coolant tank until thermostat opens.

Attach a radiator pressure tester to the tank filler neck. If pressure builds up quickly, a leak exists as result of a faulty cylinder head gasket or crack in the engine. Repair as necessary.

WARNING: DO NOT ALLOW PRESSURE TO EXCEED 117 KPA (17 PSI). TURN THE ENGINE OFF. TO RELEASE THE PRESSURE, ROCK THE TESTER FROM SIDE TO SIDE. WHEN REMOVING THE TESTER, DO NOT TURN THE TESTER MORE THAN 1/2 TURN IF THE SYSTEM IS UNDER PRESSURE.

If there is no immediate pressure increase, pump the pressure tester until the indicated pressure is within the system range. Vibration of the gauge pointer indicates compression or combustion leakage into the cooling system.

LOW COOLANT LEVEL- AERATION

CAUTION: Engine damage could occur if the coolant level is allowed to get this low. Always ensure that the coolant level is not below the add coolant mark. The baffles in the pressurized coolant tank (degasser bottle) will not allow you to see the fluid level. Check the coolant level through the pressurized coolant tank. For better visibility of the coolant level use a shop lamp to light the pressurized coolant tank and look through the pressurized coolant tank.

If the coolant level in the radiator drops below the top of radiator core tubes, air will enter the cooling system.

Low coolant level can cause the thermostat pellet to be suspended in air instead of coolant. This will cause the thermostat to open later, which in turn causes higher coolant temperature. Air trapped in the cooling system also reduces the amount of coolant circulating in the heater core resulting in low heat output.

BELT DIAGNOSIS

When diagnosing serpentine accessory drive belts, small cracks that run across the ribbed surface of the belt from rib to rib (Fig. 10), are considered normal. These are not a reason to replace the belt. However, cracks running along a rib (not across) are **not** nor

mal. Any belt with cracks running along a rib must be replaced (Fig. 10). Also replace the belt if it has excessive wear, frayed cords or severe glazing.

Refer to the Serpentine Drive Belt Diagnosis chart for further belt diagnosis.

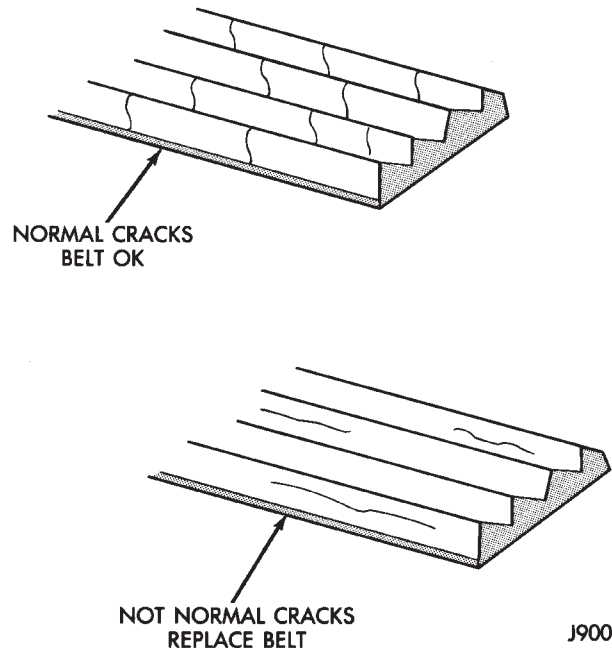


Fig. 10 Serpentine Belt Wear Patterns

SERVICE PROCEDURES

COOLANT LEVEL CHECK

The coolant level is checked and adjusted at the pressurized coolant tank. The tank is located at the right-rear side of the engine compartment and is mounted as the highest point of the cooling system. This will allow any air or vapor exceeding the pressure/vent cap rating to escape through the cap. The coolant tank is equipped with a cam type pressure/vent cap. Refer to Pressure/Vent Cap for additional information.

A coolant reserve/overflow system with a separate tank is not used with the 2.5L diesel engine.

(1) Add coolant into the coolant tank up to the COLD mark. **If possible, only add coolant when the engine is cold. Coolant level in a warm engine will be higher in the tank due to thermal expansion.**

(2) After the engine has been operated through a few heat-up and cool-down cycles, recheck the coolant level in the tank.

DRAINING COOLING SYSTEM

The cooling system is equipped with a pressurized coolant tank using a pressure/vent cap.

SERVICE PROCEDURES (Continued)

CONDITION	POSSIBLE CAUSES	CORRECTION
RIB CHUNKING (ONE OR MORE RIBS HAS SEPARATED FROM BELT BODY)	<ol style="list-style-type: none"> 1. Foreign objects imbedded in pulley grooves. 2. Installation damage. 	<ol style="list-style-type: none"> 1. Remove foreign objects from pulley grooves. Replace belt. 2. Replace belt.
RIB OR BELT WEAR	<ol style="list-style-type: none"> 1. Pulley(s) misaligned. 2. Abrasive environment. 3. Rusted pulley(s). 4. Sharp or jagged pulley groove tips. 5. Rubber deteriorated. 	<ol style="list-style-type: none"> 1. Align pulley(s). 2. Clean pulley(s). Replace belt if necessary. 3. Clean rust from pulley(s). 4. Replace pulley. 5. Replace belt.
LONGITUDINAL BELT CRACKING (CRACKS BETWEEN TWO RIBS)	<ol style="list-style-type: none"> 1. Belt has mistracked from pulley groove. 2. Pulley groove tip has worn away rubber to tensile member. 	<ol style="list-style-type: none"> 1. Replace belt. 2. Replace belt.
BELT SLIPS	<ol style="list-style-type: none"> 1. Belt slipping because of insufficient tension. 2. Incorrect belt. 3. Belt or pulley subjected to substance (belt dressing, oil, ethylene glycol) that has reduced friction. 4. Driven component bearing failure. 5. Belt glazed and hardened from heat and excessive slippage. 	<ol style="list-style-type: none"> 1. Replace automatic belt tensioner. 2. Replace belt. 3. Replace belt and clean pulleys. 4. Replace faulty component bearing. 5. Replace belt.
"GROOVE JUMPING" (BELT DOES NOT MAINTAIN CORRECT POSITION ON PULLEY)	<ol style="list-style-type: none"> 1. Belt tension either too high or too low. 2. Incorrect belt. 3. Pulley(s) not within design tolerance. 4. Foreign object(s) in grooves. 4. Pulley misalignment. 5. Belt cordline is broken. 	<ol style="list-style-type: none"> 1. Replace automatic belt tensioner. 2. Replace belt. 3. Replace pulley(s). 4. Remove foreign objects from grooves. 4. Check and replace. 5. Replace belt.
BELT BROKEN (NOTE: IDENTIFY AND CORRECT PROBLEM BEFORE NEW BELT IS INSTALLED)	<ol style="list-style-type: none"> 1. Excessive tension. 2. Incorrect belt. 3. Tensile member damaged during belt installation. 4. Severe misalignment. 5. Bracket, pulley, or bearing failure. 	<ol style="list-style-type: none"> 1. Replace belt and automatic belt tensioner. 2. Replace belt. 3. Replace belt. 4. Check and replace. 5. Replace defective component and belt.
NOISE (OBJECTIONAL SQUEAL, SQUEAK, OR RUMBLE IS HEARD OR FELT WHILE DRIVE BELT IS IN OPERATION)	<ol style="list-style-type: none"> 1. Belt slippage. 2. Bearing noise. 3. Belt misalignment. 4. Belt-to-pulley mismatch. 	<ol style="list-style-type: none"> 1. Replace belt or automatic belt tensioner. 2. Locate and repair. 3. Replace belt. 4. Install correct belt.

SERVICE PROCEDURES (Continued)

WARNING: DO NOT REMOVE THE CYLINDER BLOCK DRAIN-PLUG, THE COOLANT TANK CAP, THE RADIATOR FILL VENT VALVE, OR LOOSEN THE RADIATOR DRAINCOCK WITH THE SYSTEM HOT AND PRESSURIZED. SERIOUS BURNS FROM THE COOLANT CAN OCCUR.

WARNING: IF VEHICLE HAS BEEN RUN RECENTLY, WAIT AT LEAST 15 MINUTES BEFORE REMOVING COOLANT TANK CAP. WITH A RAG, SQUEEZE THE UPPER RADIATOR HOSE TO CHECK IF SYSTEM IS UNDER PRESSURE. PLACE A RAG OVER THE CAP. VERY SLOWLY ROTATE THE CAP COUNTERCLOCKWISE ALLOWING PRESSURE TO SLOWLY RELEASE. AFTER ALL PRESSURE HAS BEEN RELEASED, REMOVE THE COOLANT TANK CAP COMPLETELY.

DO NOT WASTE reusable coolant. If the solution is clean, drain the coolant into a clean container for reuse.

(1) Observe the previous **WARNINGS** and remove the coolant tank pressure/vent cap.

(2) The plastic radiator draincock is located on the bottom of the left radiator tank. It can be accessed from the bottom of vehicle.

(a) Attach one end of a 24 inch long X 1/4 inch ID drain-hose to the nipple below the radiator draincock.

(b) Put the other end of drain-hose into a clean container.

(c) Open the draincock (counterclockwise as viewed from left side of vehicle) and drain coolant from radiator.

(3) If the complete cooling system must be drained, raise the vehicle and remove the cylinder block drain-plug (Fig. 11). This hex-headed plug is located on the right/rear side of the engine above the starter motor.

REFILLING COOLING SYSTEM

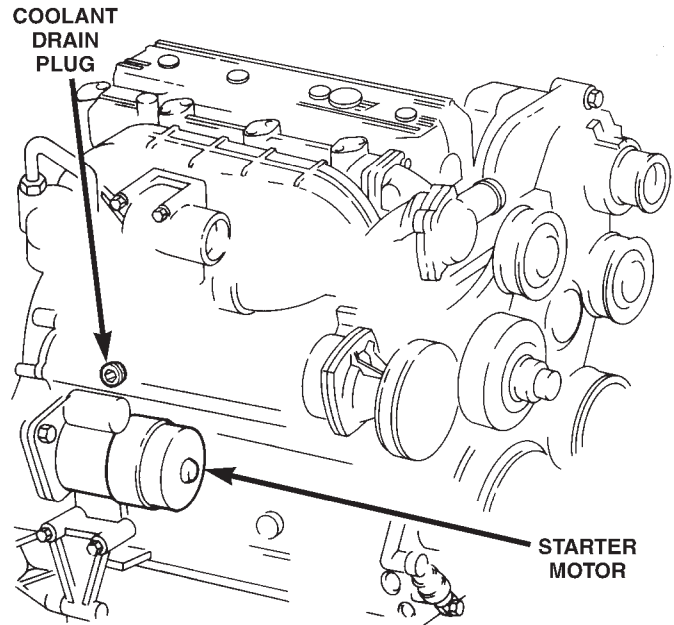
The cooling system is equipped with a pressurized coolant tank using a pressure/vent cap. Refilling of the system is done through this tank.

NOTE: The radiator draincock is equipped with a rubber o-ring. Do not over tighten draincock.

(1) Tighten the radiator draincock and (if removed), the cylinder block drain-plug.

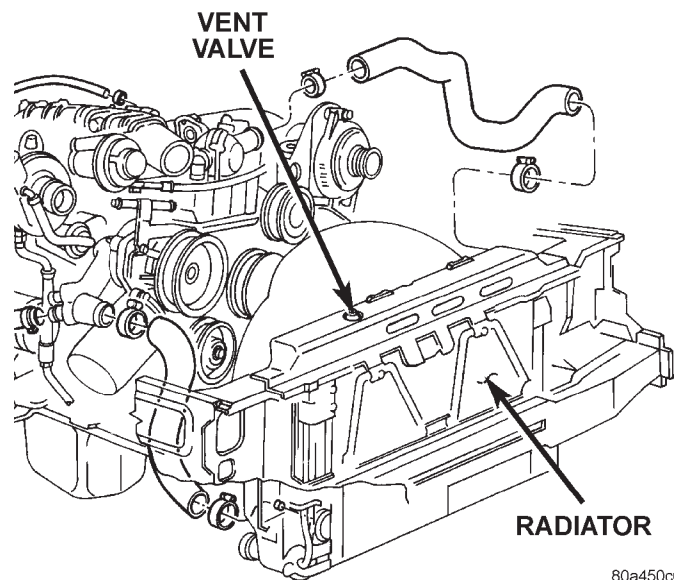
(2) Remove the plastic radiator fill vent valve (unscrews counter-clockwise) from the radiator. The fill vent valve is located on the top of the right radiator tank (Fig. 12).

(3) With the fill vent valve removed, proceed to fill the system using a 50/50 mixture of water and antifreeze as described in the Coolant section of this group.



80a243e3

Fig. 11 Cylinder Block Drain-Plug



80a450c6

Fig. 12 Radiator Fill Vent Valve

(4) Continue to fill the cooling system until coolant is observed escaping from the fill vent opening. When this occurs, install the fill vent valve. **The plastic fill vent valve is equipped with a rubber o-ring. Do not over tighten the fill vent valve.**

(5) Continue to fill the system until the coolant tank is full.

(6) Install and tighten the coolant tank pressure/vent cap. **Do not use any type of tool when tightening the cap. Hand tighten only.**

(7) With the heater control unit in the HEAT position, operate engine with coolant tank cap tightened.

SERVICE PROCEDURES (Continued)

(8) After engine has reached normal operating temperature, shut engine off and allow it to cool.

(9) Remove coolant tank cap.

(10) Add coolant into the coolant tank up to the COLD mark. **If possible, only add coolant when the engine is cold. Coolant level in a warm engine will be higher in the tank due to thermal expansion.**

(11) After the engine has been operated through a few heat-up and cool-down cycles, recheck the coolant level in the tank.

COOLANT REPLACEMENT

It is recommended that the cooling system be drained and flushed at 84,000 kilometers (52,500 miles), or 3 years, whichever occurs first. Then every two years, or 48,000 kilometers (30,000 miles), whichever occurs first.

REMOVAL AND INSTALLATION

RADIATOR

WARNING: DO NOT REMOVE THE CYLINDER BLOCK DRAIN-PLUG, THE COOLANT TANK CAP, THE RADIATOR FILL VENT VALVE, OR LOOSEN THE RADIATOR DRAINCOCK WITH THE SYSTEM HOT AND PRESSURIZED. SERIOUS BURNS FROM THE COOLANT CAN OCCUR.

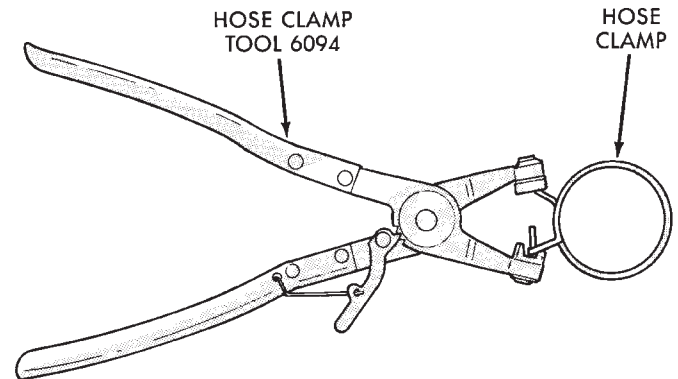
DO NOT WASTE reusable coolant. If solution is clean, drain coolant into a clean container for reuse.

WARNING: CONSTANT TENSION HOSE CLAMPS ARE USED ON MOST COOLING SYSTEM HOSES. WHEN REMOVING OR INSTALLING, USE ONLY TOOLS DESIGNED FOR SERVICING THIS TYPE OF CLAMP (Fig. 13). ALWAYS WEAR SAFETY GLASSES WHEN SERVICING CONSTANT TENSION CLAMPS.

CAUTION: A number or letter is stamped into the tongue of constant tension clamps (Fig. 14). If replacement is necessary, use only an original equipment clamp with matching number or letter.

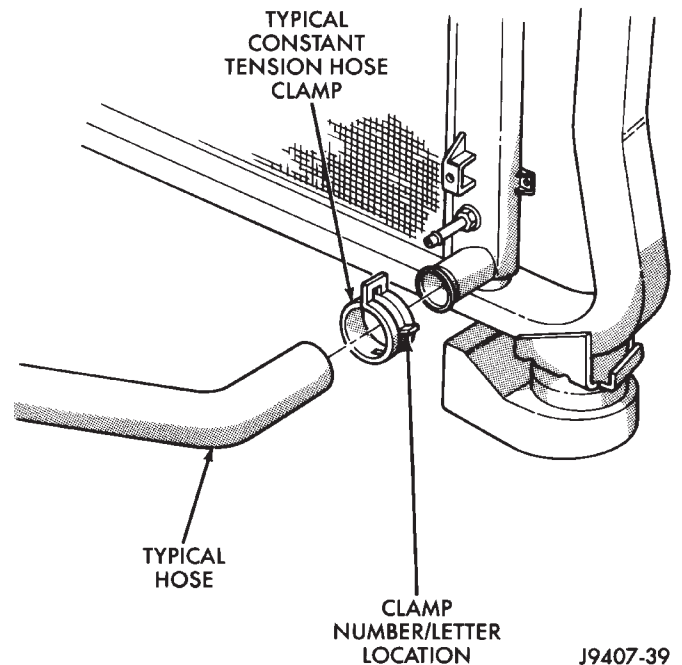
REMOVAL

- (1) Disconnect negative battery cable at battery.
- (2) Observe the previous **WARNINGS**.
- (3) Drain cooling system. Refer to Draining Cooling System in this group.
- (4) Remove the upper fan shroud-to-upper crossmember mounting bolts. One of the bolts is mounted vertically at the bottom of the fan shroud.



J9207-36

Fig. 13 Hose Clamp Tool



J9407-39

Fig. 14 Clamp Number/Letter Location

(5) Lift the fan shroud up until alignment tabs at the bottom are clear of slots in bracket at bottom of radiator. Slip the fan shroud rearward and position it over the fan blades.

(6) Remove radiator hose clamps and remove radiator hoses.

(7) Mark the position of the hood latch striker on the radiator crossmember and remove hood latch striker.

(8) Remove radiator upper crossmember.

(9) If equipped with air conditioning, separate the radiator from the A/C condenser by removing the condenser-to-radiator mounting brackets.

(10) Lift radiator straight up and out of engine compartment taking care not to damage radiator or A/C condenser fins.

REMOVAL AND INSTALLATION (Continued)

INSTALLATION

The radiator is equipped with two alignment dowels (Fig. 15). They are located on the bottom of the plastic side tanks and fit into rubber grommets located in the front lower crossmember.

(1) Carefully lower the radiator into engine compartment. Position the alignment dowels on the bottom of radiator into the rubber grommets in front lower crossmember (Fig. 15).

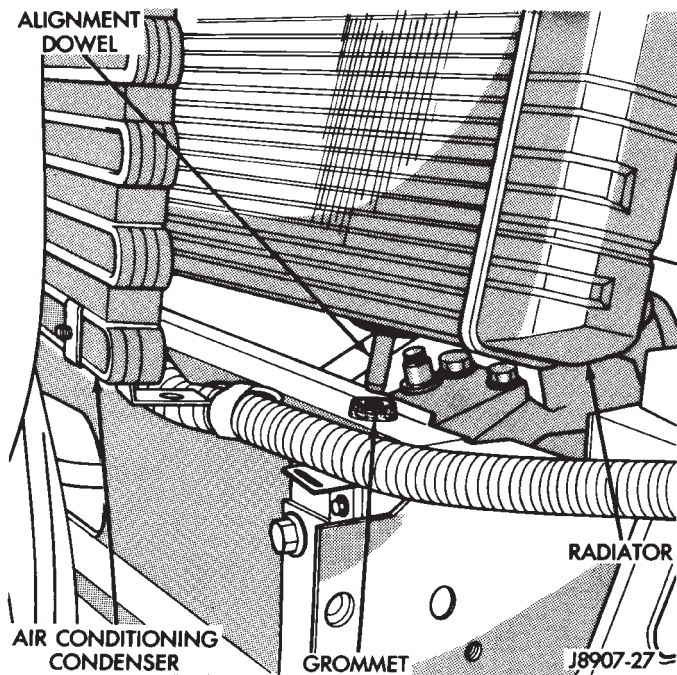


Fig. 15 Radiator Alignment Dowels—Typical

- (2) If equipped with air conditioning, attach condenser to radiator with mounting brackets.
- (3) Install radiator upper crossmember.
- (4) Install hood latch striker.
- (5) Connect radiator upper and lower hoses.
- (6) Insert alignment tabs at bottom of fan shroud into slots in bracket at bottom of radiator. Install and tighten fan shroud bolts to 3 N·m (31 in. lbs.) torque.
- (7) Connect negative battery cable.
- (8) Fill cooling system with correct coolant. Refer to Refilling Cooling System in this group.
- (9) Start and warm the engine. Check for coolant leaks.

FAN BLADE REMOVAL

FAN BLADE REMOVAL

Accessory drive belt removal is not necessary for fan blade or viscous fan drive removal.

- (1) Disconnect negative battery cable from battery.
- (2) The thermal viscous fan drive/fan blade assembly is attached (threaded) to the fan pulley shaft (Fig. 16). Remove fan blade/viscous fan drive assembly from fan pulley by turning mounting nut counter-clockwise as

viewed from front. Threads on viscous fan drive are **RIGHT HAND**. Snap-On® 36 MM Fan Wrenches (number SP346) can be used to turn the mounting nut and to hold the fan pulley from rotating.

(3) Do not attempt to remove fan/viscous fan drive assembly from vehicle at this time.

(4) Do not unbolt fan blade assembly from viscous fan drive at this time.

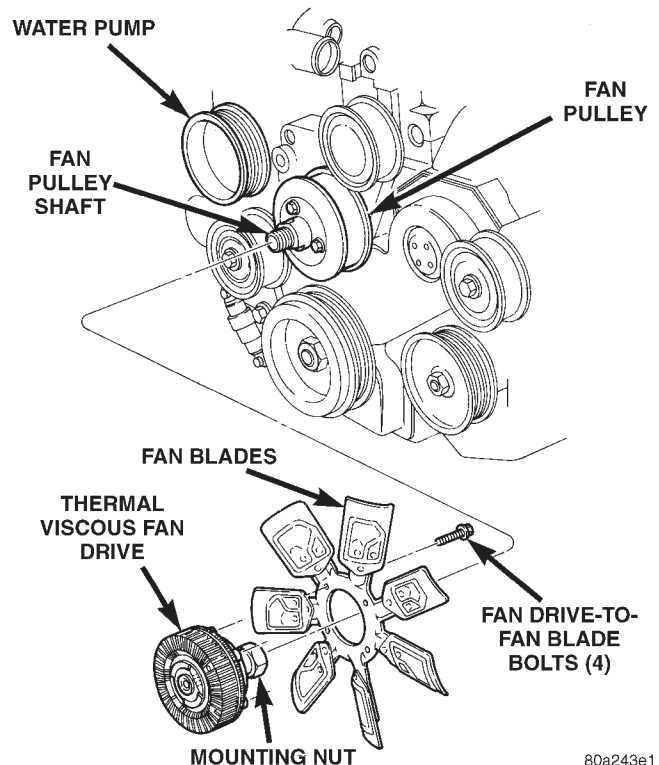


Fig. 16 Thermal Viscous Fan Drive and Blade Assembly

(5) Remove the fan shroud mounting bolts. One of the bolts is mounted vertically at the bottom of shroud.

(6) Remove fan shroud and fan blade/viscous fan drive assembly as a complete unit from vehicle.

(7) After removing fan blade/viscous fan drive assembly, **do not** place viscous fan drive in horizontal position. If stored horizontally, silicone fluid in the viscous fan drive could drain into its bearing assembly and contaminate lubricant.

CAUTION: Do not attempt to remove the fan pulley bolts. The fan pulley is under tension from the drive belt.

(8) Remove four bolts securing fan blade assembly to viscous fan drive (Fig. 16).

FAN BLADE INSTALLATION

(1) Install fan blade assembly to viscous fan drive. Tighten bolts (Fig. 16) to 23 N·m (200 in. lbs.) torque.

REMOVAL AND INSTALLATION (Continued)

(2) Position fan shroud and fan blade/viscous fan drive assembly to vehicle as a complete unit.

(3) Install and tighten fan shroud bolts to 3 N·m (31 in. lbs.) torque.

(4) Install fan blade/viscous fan drive assembly to fan pulley shaft (Fig. 16).

(5) Connect negative battery cable.

VISCOUS FAN DRIVE

The thermal viscous fan drive (Fig. 17) is a silicone-fluid-filled coupling. It connects the fan blade assembly to the fan pulley. The coupling allows the fan to be driven in a normal manner. This is done at low engine speeds while limiting the top speed of the fan to a predetermined maximum level at higher engine speeds. A bimetallic spring coil is located on the front face. This spring coil reacts to the temperature of the radiator discharge air. It engages the viscous fan drive for higher fan speed if the air temperature from the radiator rises above a certain point. Until additional engine cooling is necessary, the fan will remain at a reduced rpm regardless of engine speed.

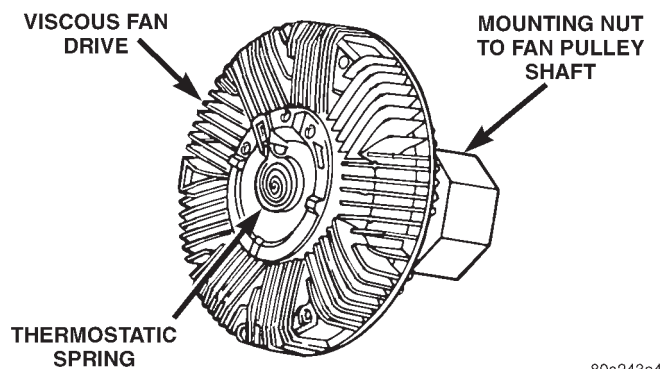


Fig. 17 Viscous Fan Drive

The viscous fan drive will only engage when sufficient heat is present. This is when the air flowing through the radiator core causes a reaction from the bimetallic coil. It then increases fan speed to provide the necessary additional engine cooling.

Once the engine has cooled, the radiator discharge temperature will drop. The bimetallic coil again reacts and the fan speed is reduced to the previous disengaged speed.

CAUTION: Some engines equipped with serpentine drive belts have reverse rotating fans and viscous fan drives. They are marked with the word **REVERSE** to designate their usage. Installation of the wrong fan or viscous fan drive can result in engine overheating.

NOISE

NOTE: It is normal for fan noise to be louder (roaring) when:

- The underhood temperature is above the engagement point for the viscous drive coupling. This may occur when ambient (outside air temperature) is very high.
- Engine loads and temperatures are high such as when towing a trailer.
- Cool silicone fluid within the fan drive unit is being redistributed back to its normal disengaged (warm) position. This can occur during the first 15 seconds to one minute after engine start-up on a cold engine.

LEAKS

Viscous fan drive operation is not affected by small oil stains near the drive bearing. If leakage appears excessive, replace the fan drive unit.

THERMOSTAT

REMOVAL

WARNING: DO NOT REMOVE THE CYLINDER BLOCK DRAIN-PLUG, THE COOLANT TANK CAP, THE RADIATOR FILL VENT VALVE, OR LOOSEN THE RADIATOR DRAINCOCK WITH THE SYSTEM HOT AND PRESSURIZED. SERIOUS BURNS FROM THE COOLANT CAN OCCUR.

DO NOT WASTE reusable coolant. If the solution is clean, drain the coolant into a clean container for reuse.

(1) Drain the coolant from the radiator until the level is below the thermostat housing. Refer to Draining Cooling System for procedures.

WARNING: CONSTANT TENSION HOSE CLAMPS ARE USED ON MOST COOLING SYSTEM HOSES. WHEN REMOVING OR INSTALLING, USE ONLY TOOLS DESIGNED FOR SERVICING THIS TYPE OF CLAMP (Fig. 13). ALWAYS WEAR SAFETY GLASSES WHEN SERVICING CONSTANT TENSION CLAMPS.

CAUTION: A number or letter is stamped into the tongue of constant tension clamps (Fig. 14). If replacement is necessary, use only an original equipment clamp with matching number or letter.

REMOVAL AND INSTALLATION (Continued)

- (2) Remove the upper radiator hose at the thermostat housing.
- (3) Remove the four thermostat housing bolts (Fig. 18)

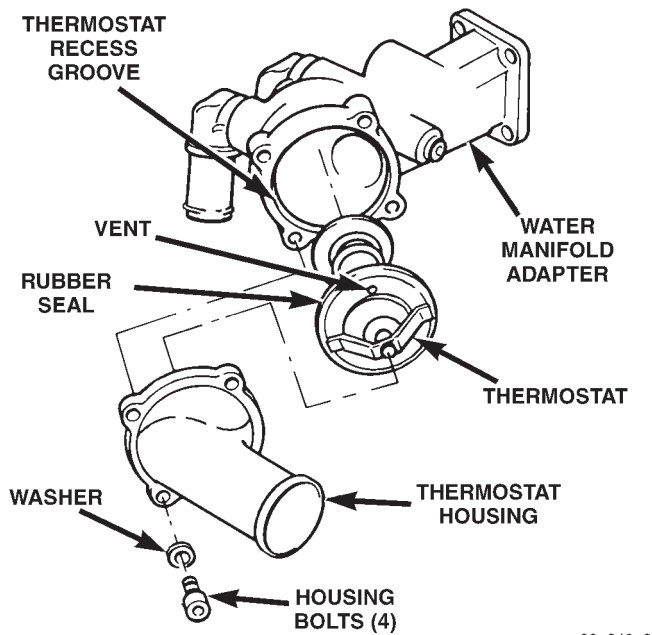


Fig. 18 Thermostat Removal/Installation

- (4) Remove the thermostat housing from the water manifold.
- (5) Remove the thermostat and rubber seal from the water manifold.
- (6) Thoroughly clean the rubber seal mating surfaces.

INSTALLATION

- (1) Install a new rubber seal around the outer lip of the thermostat (a notch is provided in the rubber seal). Do not apply any adhesive to this seal.
- (2) Install the replacement thermostat and rubber seal as one assembly into the water manifold adapter (the pointed end of the thermostat should be facing towards the front of engine (Fig. 18). Observe the recess groove in the water manifold adapter. Be sure the thermostat vent is in the 12 o'clock position (Fig. 18).
- (3) Position the thermostat housing and four bolts to the water manifold.

CAUTION: Tightening the thermostat housing unevenly or with the thermostat out of its recess groove, may result in a cracked housing.

- (4) Tighten the four housing bolts to 11 N·m (98 in. lbs.) torque.
- (5) Install radiator hose to thermostat housing.

- (6) Be sure that the radiator drain is tightly closed. Fill the cooling system to the correct level with the required coolant mixture. Refer to Refilling Cooling System in this group for procedures.

(7) Start and warm the engine. Check thermostat and hose for leaks.

DRIVE BELT

CAUTION: The drive belt on the 2.5L diesel engine is equipped with a spring loaded automatic belt tensioner. After belt installation, do not attempt to check belt tension with a belt tension gauge.

AUTOMATIC BELT TENSIONER

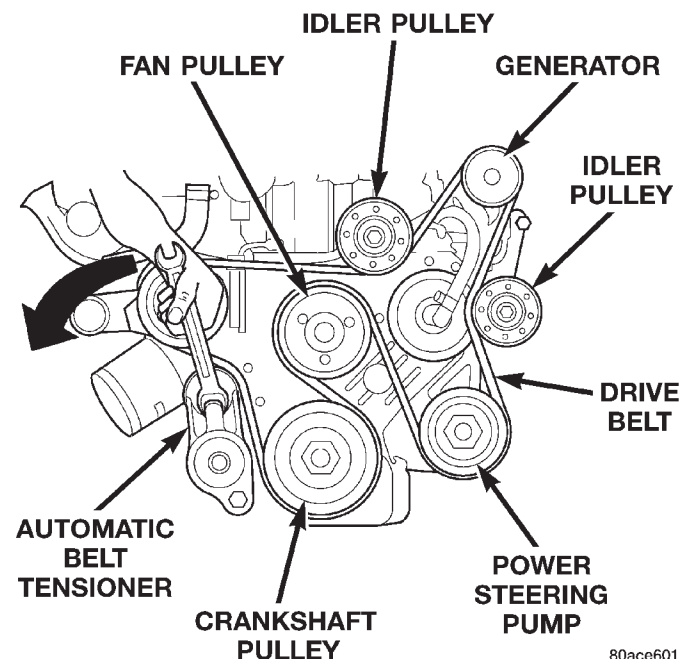


Fig. 19 Automatic Belt Tensioner Assembly

WATER PUMP

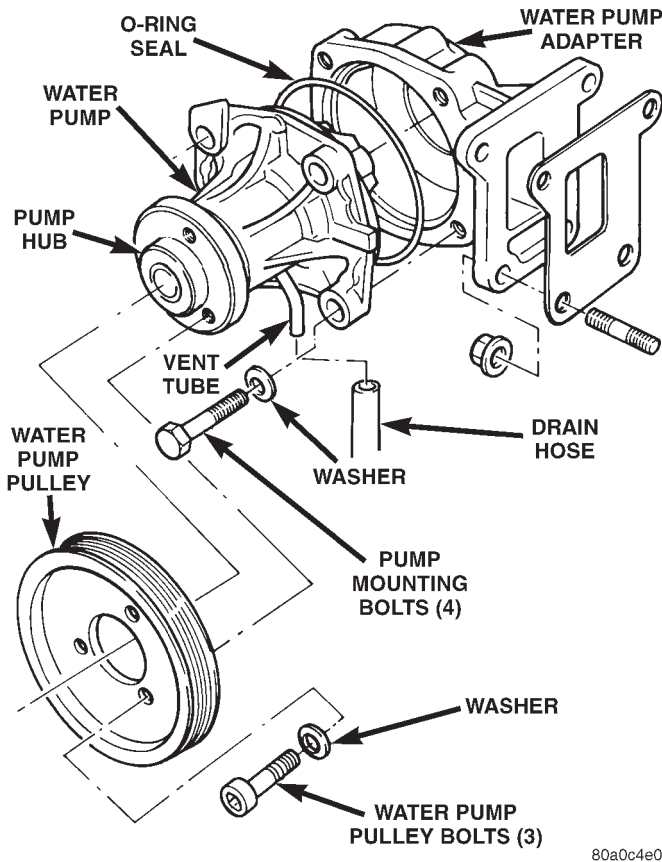
REMOVAL

The water pump can be removed without discharging the air conditioning system (if equipped).

The water pump is serviced by replacing the pump and its impeller only. The water pump adapter (Fig. 20) does not have to be removed. The pump impeller is pressed on the rear of the pump shaft and bearing assembly. The pump is serviced only as a complete assembly with the impeller, housing, hub and bearing.

REMOVAL AND INSTALLATION (Continued)

A rubber o-ring seal (instead of a gasket) is used as a seal between the water pump and the water pump adapter.



80a0c4e0

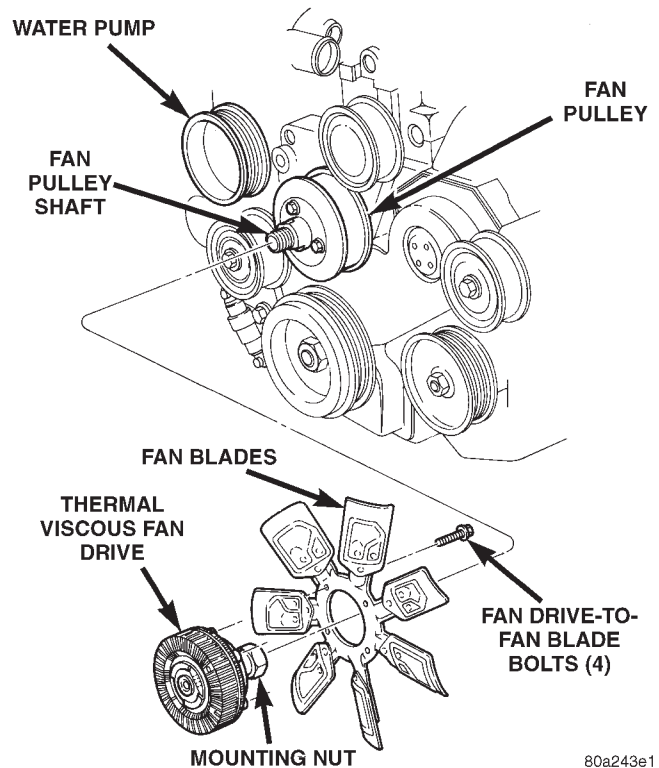
Fig. 20 WATER PUMP REMOVAL/INSTALL— TYPICAL

WARNING: DO NOT REMOVE THE CYLINDER BLOCK DRAIN-PLUG, THE COOLANT TANK CAP, THE RADIATOR FILL VENT VALVE, OR LOOSEN THE RADIATOR DRAINCOCK WITH THE SYSTEM HOT AND PRESSURIZED. SERIOUS BURNS FROM THE COOLANT CAN OCCUR.

DO NOT WASTE reusable coolant. If the solution is clean, drain coolant into a clean container for reuse.

- (1) Disconnect negative battery cable at battery.
- (2) Drain the cooling system. Refer to Draining Cooling System in this group.
- (3) The thermal viscous fan drive and the fan blade assembly are attached (threaded) to the fan pulley shaft (Fig. 21). Remove the fan/fan drive assembly from the fan pulley by turning the mounting nut counterclockwise (as viewed from front). Threads on the fan drive are **RIGHT HAND**. Snap-On® 36 MM Fan Wrenches (number SP346) can be used to turn the mounting nut and to hold the fan pulley from rotating.

(4) If the water pump is being replaced, do not unbolt the fan blade assembly (Fig. 21) from the thermal viscous fan drive.



80a243e1

Fig. 21 Thermal Viscous Fan Drive and Blade Assembly

(5) Remove the upper fan shroud-to-upper cross-member mounting bolts. One of the bolts is mounted vertically at the bottom of the fan shroud.

(6) Slip the fan shroud rearward. Remove the fan shroud and viscous drive/fan blade together as one assembly from the engine compartment.

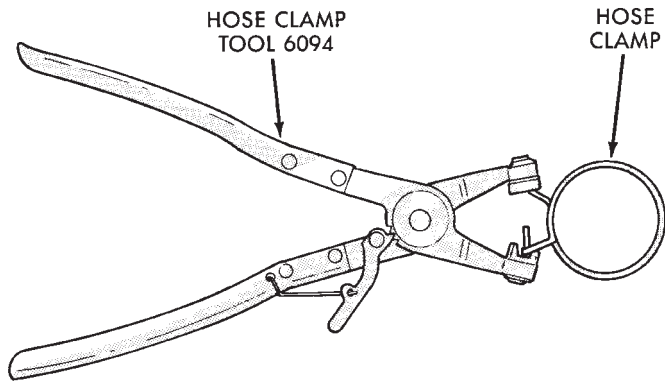
(7) Loosen **but do not remove** the 3 water pump pulley bolts (Fig. 20).

(8) Remove the drive belt by removing the automatic belt tensioner. For procedures, refer to Belt Removal/Installation in the Engine Accessory Drive Belts section of this group.

WARNING: CONSTANT TENSION HOSE CLAMPS ARE USED ON MOST COOLING SYSTEM HOSES. WHEN REMOVING OR INSTALLING, USE ONLY TOOLS DESIGNED FOR SERVICING THIS TYPE OF CLAMP (Fig. 22). ALWAYS WEAR SAFETY GLASSES WHEN SERVICING CONSTANT TENSION CLAMPS.

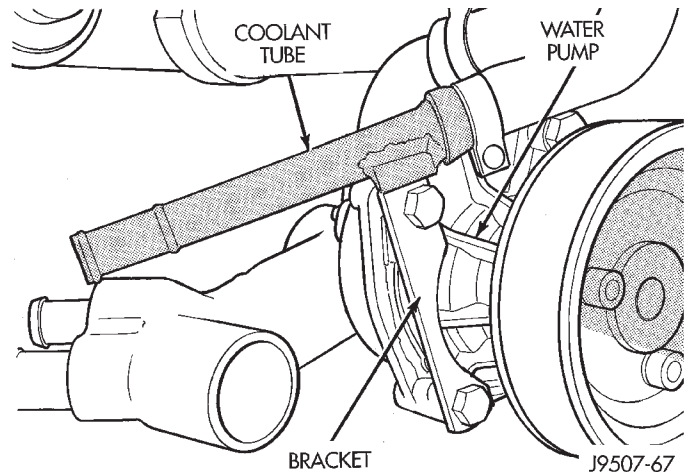
CAUTION: A number or letter is stamped into the tongue of constant tension clamps (Fig. 23). If replacement is necessary, use only an original equipment clamp with matching number or letter.

REMOVAL AND INSTALLATION (Continued)



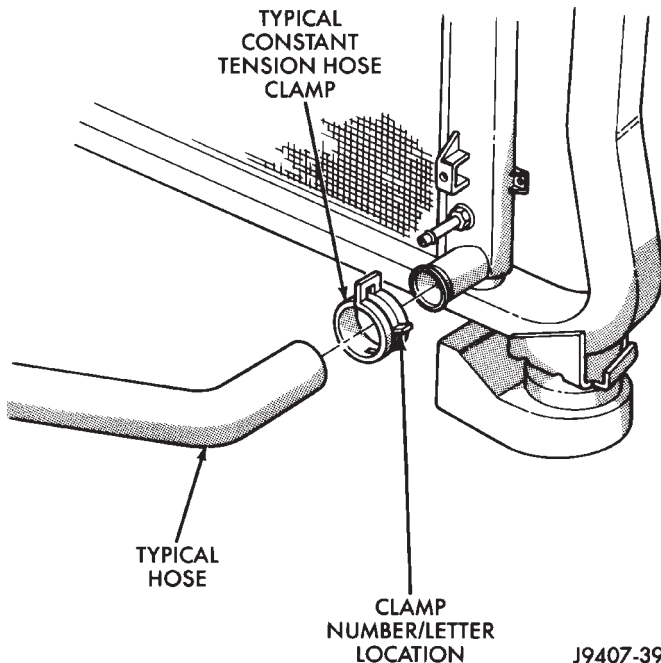
J9207-36

Fig. 22 Hose Clamp Tool



J9507-67

Fig. 24 Coolant Tube at Water Pump



J9407-39

Fig. 23 Clamp Number/Letter Location

(9) A metal coolant tube (used to connect rubber coolant hoses), and its mounting bracket are attached to the front of the water pump (Fig. 24). A rubber hose connects this tube to the engine. Disconnect the hose clamp and rubber hose at the back of the thermostat. Position the hose to the side.

(10) Remove the 3 water pump pulley bolts (Fig. 20).

(11) Remove the water pump pulley from the water pump.

(12) Disconnect the drain hose from the vent tube at the bottom of water pump (Fig. 20).

(13) Remove the 4 water pump mounting bolts (Fig. 20).

(14) Remove water pump from engine.

INSTALLATION

(1) Clean the o-ring mating surfaces. If the original pump is to be reinstalled, remove any deposits or other foreign material. Inspect the water pump, water pump adapter and water pump mating surfaces for erosion or damage from cavitation.

(2) Position a new rubber o-ring seal (Fig. 20) between the pump and pump adapter. Hold the seal with petroleum jelly.

(3) Position the pump to the engine.

(4) Position the metal coolant tube and its mounting bracket to the pump.

(5) Install the four water pump mounting bolts. Tighten bolts to 24 N·m (18 ft. lbs.) torque.

(6) Install drain hose to vent tube at bottom of pump.

(7) Position the water pump pulley to the water pump.

(8) Install the water pump pulley bolts finger tight.

(9) Install the rubber coolant hose near the thermostat.

(10) Install the drive belt and belt tensioner. For procedures, refer to Belt Removal/Installation in the Engine Accessory Drive Belts section of this group.

(11) Tighten the water pump pulley bolts to 24 N·m (18 ft. lbs.) torque.

(12) Position the viscous drive/fan blade and fan shroud to the engine compartment as one assembly.

(13) Install the thermal viscous fan drive and fan blade to fan pulley. Tighten to 56 N·m (41 ft. lbs.) torque.

(14) Install and tighten fan shroud mounting bolts to 3 N·m (31 in. lbs.) torque.

(15) Fill cooling system with coolant and check for leaks. Refer to Refilling Cooling System in this group.

(16) Connect battery cable to battery.

(17) Start and warm the engine. Check for leaks.

CLEANING AND INSPECTION

WATER PUMP

INSPECTION

Replace the water pump assembly if it has any of the following conditions:

- The body is cracked or damaged
- Water leaks from the shaft seal. This is evident by traces of coolant below the vent tube drain hose
- Loose or rough turning bearing.
- Impeller rubs either the water pump body or water pump adapter.

RADIATOR CLEANING

The radiator and air conditioning fins should be cleaned when an accumulation of bugs, leaves etc. has occurred. Clean radiator fins are necessary for good heat transfer. With the engine cold, apply cold water and compressed air to the back (engine side) of the radiator to flush the radiator and/or A/C condenser of debris.

FAN BLADE

INSPECTION

The fan cannot be repaired. If fan is damaged, it must be replaced. Inspect fan as follows:

- (1) Remove fan blade and viscous fan drive as an assembly from the engine.

- (2) Remove fan blade assembly from viscous fan drive unit (four bolts) (Fig. 25).

- (3) Lay fan on a flat surface with leading edge facing down. With tip of blade touching flat surface, replace fan if clearance between opposite blade and surface is greater than 2.0 mm (.090 inch). Rocking motion of opposite blades should not exceed 2.0 mm (.090 inch). Test all blades in this manner.

WARNING: DO NOT ATTEMPT TO BEND OR STRAIGHTEN FAN BLADES IF NOT WITHIN SPECIFICATIONS.

- (4) Inspect fan assembly for cracks, bends, loose rivets or broken welds. Replace fan if any damage is found.

CAUTION: If fan blade assembly is replaced because of mechanical damage, the fan pulley bearing and viscous fan drive should also be inspected. These components could have been damaged due to excessive vibration.

CAUTION: Some engines equipped with serpentine drive belts have reverse rotating fans and viscous fan drives. They are marked with the word REVERSE to designate their usage. Installation of the wrong fan or viscous fan drive can result in engine overheating.

COOLING SYSTEM CLEANING/REVERSE FLUSHING

CAUTION: The cooling system normally operates at 90-to-117 kPa (13- to-17 psi) pressure. Exceeding this pressure may damage the radiator or hoses.

CLEANING

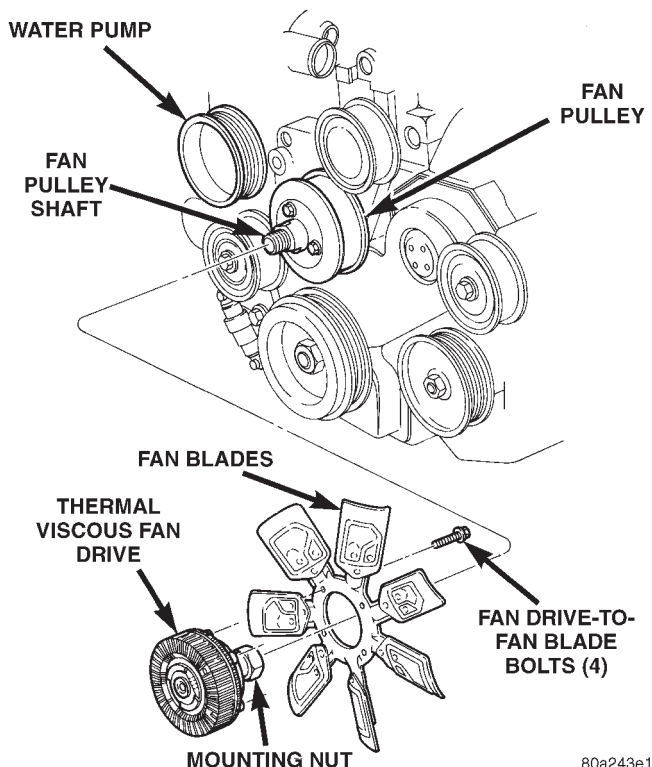
Drain cooling system and refill with water. Run engine with coolant tank pressure/vent cap installed until upper radiator hose is hot. Stop engine and drain water from system. If water is dirty, fill system with water, run engine and drain system. Repeat until water drains clean.

REVERSE FLUSHING

Reverse flushing of the cooling system is the forcing of water through the cooling system. This is done using air pressure in the opposite direction of normal coolant flow. It is usually only necessary with very dirty systems with evidence of partial plugging.

REVERSE FLUSHING RADIATOR

Disconnect the radiator hoses from the radiator fittings. Attach a section of radiator hose to the radiator bottom outlet fitting and insert the flushing gun.



80a243e1

Fig. 25 Thermal Viscous Fan Drive and Blade Assembly

CLEANING AND INSPECTION (Continued)

Connect a water supply hose and air supply hose to the flushing gun.

CAUTION: The cooling system normally operates at 90-to-117 kPa (13- to-17 psi) pressure. Exceeding this pressure may damage the radiator or hoses.

Allow the coolant tank and radiator to fill with water. When radiator is filled, apply air in short blasts allowing radiator to refill between blasts. Continue this reverse flushing until clean water flows out through rear of radiator cooling tube passages. For more information, refer to operating instructions supplied with flushing equipment. Have radiator cleaned more extensively by a radiator repair shop.

REVERSE FLUSHING ENGINE

Drain the cooling system. Remove the thermostat housing and thermostat. Install the thermostat housing. Disconnect the radiator upper hose from the radiator and attach the flushing gun to the hose. Disconnect the radiator lower hose from the water pump. Attach a lead away hose to the water pump inlet fitting.

CAUTION: Be sure that the heater water control valve is closed (heat off). This is done to prevent coolant flow with scale and other deposits from entering the heater core.

Connect the water supply hose and air supply hose to the flushing gun. Allow the engine to fill with water. When the engine is filled, apply air in short blasts, allowing the system to fill between air blasts. Continue until clean water flows through the lead away hose. For more information, refer to operating instructions supplied with flushing equipment.

Remove the lead away hose, flushing gun, water supply hose and air supply hose. Remove the thermostat housing and install thermostat. Install the thermostat housing with a new replacement rubber seal. Refer to Thermostat Installation. Connect the radiator hoses. Refill the cooling system with the correct antifreeze/water mixture.

CHEMICAL CLEANING

In some instances, use a radiator cleaner (Mopar Radiator Kleen or equivalent) before flushing. This will soften scale and other deposits and aid the flushing operation.

CAUTION: Be sure instructions on the container are followed.

ADJUSTMENTS

DRIVE BELT TENSION

Initial belt adjustment is done with a adjustable tensioner pulley. After the initial adjustment is performed, an automatic belt tensioner is used to maintain correct belt tension at all times. For other tensioner information and removal/installation procedures, refer to Automatic Belt Tensioner in this group. Due to use of this belt tensioner, DO NOT attempt to use a belt tension gauge on the 2.5L diesel engine.

SPECIFICATIONS

COOLING SYSTEM CAPACITY

2.5L Diesel Engine: 9.8 Liters (10.4 qts.)

THERMOSTAT

Starts to open at 80°C (176°F).

TORQUE SPECIFICATIONS

DESCRIPTION	TORQUE
Automatic Belt Tensioner-to-Mounting Bracket Bolt (1)	75 N·m
Automatic Belt Tensioner to Block Bolts (2)	121 N·m
Coolant Tank Cap	5 N·m
Fan Shroud-to-Radiator Mounting Bolts	3 N·m
Fan Blade-to-Thermal Viscous Fan Drive Bolts	23 N·m
Hose Clamps	4 N·m
Radiator-to-A/C Condenser Isolator Nuts	6 N·m
Thermal Viscous Fan Drive-to-Fan Hub Bolts	56 N·m
Thermostat Housing Bolts	11 N·m
Water Pump Mounting Bolts	24 N·m
Water Pump Pulley Bolts	24 N·m

BATTERY

CONTENTS

	page	page
GENERAL INFORMATION		
INTRODUCTION	1	
OVERVIEW	1	
DESCRIPTION AND OPERATION		
BATTERY MOUNTING	3	
BATTERY SIZE AND RATINGS	2	
BATTERY	2	
DIAGNOSIS AND TESTING		
BATTERY	3	
BUILT-IN TEST INDICATOR	6	
HYDROMETER TEST	7	
IGNITION-OFF DRAW TEST	10	
LOAD TEST	9	
OPEN-CIRCUIT VOLTAGE TEST	8	
VOLTAGE DROP TEST	11	
SERVICE PROCEDURES		
BATTERY CHARGING	12	
REMOVAL AND INSTALLATION		
BATTERY	14	
SPECIFICATIONS		
BATTERY	16	

GENERAL INFORMATION

OVERVIEW

The battery, starting, and charging systems operate with one another, and must be tested as a complete system. In order for the vehicle to start and charge properly, all of the components involved in these systems must perform within specifications.

Group 8A covers the battery, Group 8B covers the starting system, and Group 8C covers the charging system. Refer to Group 8W - Wiring Diagrams for complete circuit descriptions and diagrams. We have separated these systems to make it easier to locate the information you are seeking within this Service Manual. However, when attempting to diagnose any of these systems, it is important that you keep their interdependency in mind.

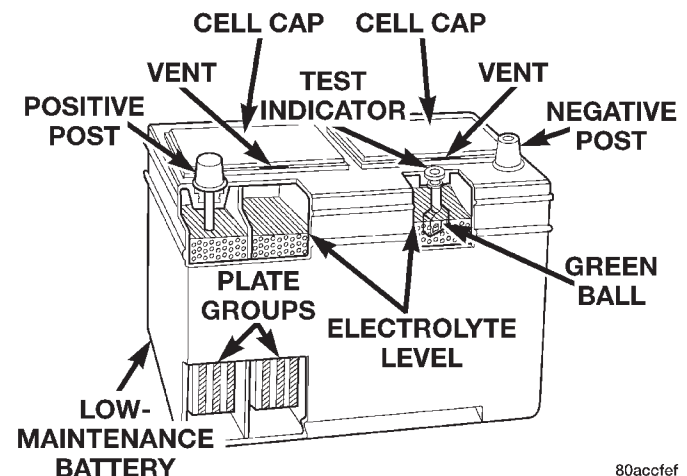
The diagnostic procedures used in these groups include the most basic conventional diagnostic methods, to the more sophisticated On-Board Diagnostics (OBD) built into the Powertrain Control Module (PCM). Use of a induction milliampere ammeter, volt/ohmmeter, battery charger, carbon pile rheostat (load tester), and 12-volt test lamp may be required.

All OBD-sensed systems are monitored by the PCM. Each monitored circuit is assigned a Diagnostic Trouble Code (DTC). The PCM will store a DTC in electronic memory for any failure it detects. See the On-Board Diagnostics Test in Group 8C - Charging System for more information.

INTRODUCTION

This section covers only battery diagnostic and service procedures. For battery maintenance procedures, refer to Group 0 - Lubrication and Maintenance. While battery charging can be considered a maintenance procedure, battery charging information is located in this group. This was done because the battery must be fully-charged before any diagnosis can be performed.

The factory-installed low-maintenance battery has removable battery cell caps. Water can be added to this battery. The battery is not sealed and has vent holes in the cell caps (Fig. 1). The chemical composition within the low-maintenance battery reduces battery gassing and water loss, at normal charge and discharge rates.



80accfef

Fig. 1 Low-Maintenance Battery - Typical

GENERAL INFORMATION (Continued)

Rapid loss of electrolyte can be caused by an overcharging condition. Be certain to diagnose the charging system before returning the vehicle to service. Refer to Group 8C - Charging System for more information.

The factory-installed battery also has a built-in test indicator (hydrometer). The color visible in the sight glass of the indicator will reveal the battery condition. See Built-In Test Indicator in this group for more information.

It is important that the battery, starting, and charging systems be thoroughly tested and inspected any time a battery needs to be charged or replaced. The cause of abnormal discharge, overcharging, or early battery failure must be diagnosed and corrected before a battery is replaced or returned to service.

DESCRIPTION AND OPERATION

BATTERY

The storage battery is a device used to store electrical energy potential in a chemical form. When an electrical load is applied to the battery terminals, an electrochemical reaction occurs within the battery. This reaction causes the battery to discharge electrical current.

The battery is made up of six individual cells that are connected in series. Each cell contains positively charged plate groups made of lead oxide, and negatively charged plate groups made of sponge lead. These dissimilar metal plates are submerged in a sulfuric acid and water solution called an electrolyte.

As the battery discharges, a gradual chemical change takes place within each cell. The sulfuric acid in the electrolyte combines with the plate materials, causing both plates to slowly change to lead sulfate. At the same time, oxygen from the positive plate material combines with hydrogen from the sulfuric acid, causing the electrolyte to become mainly water.

The chemical changes within the battery are caused by the movement of excess or free electrons between the positive and negative plate groups. This movement of electrons produces a flow of electrical current through the load device attached to the battery terminals.

As the plate materials become more similar chemically, and the electrolyte becomes less acid, the voltage potential of each cell is reduced. However, by charging the battery with a voltage higher than that of the battery, the battery discharging process is reversed.

Charging the battery gradually changes the sulfated lead plates back into sponge lead and lead oxide, and the water back into sulfuric acid. This action restores the difference in the electron charges

deposited on the plates, and the voltage potential of the battery cells.

For a battery to remain useful, it must be able to produce high-amperage current over an extended period. A battery must also be able to accept a charge, so that its voltage potential may be restored.

In addition to producing and storing electrical energy, the battery serves as a capacitor, or voltage stabilizer, for a vehicle's electrical system. It absorbs most abnormal or transient voltages caused by the switching of any of the vehicle's electrical components.

The battery is vented to release excess hydrogen gas that is created when the battery is being charged or discharged. However, even with these vents, the hydrogen gas can collect in or around the battery. If hydrogen gas is exposed to flame or sparks, it may ignite.

If the electrolyte level is low, the battery may arc internally and explode. If the battery is equipped with removable cell caps, add distilled water whenever the electrolyte level is below the top of the plates. If the battery cell caps cannot be removed, the battery must be replaced if the electrolyte level becomes low.

BATTERY SIZE AND RATINGS

The battery Group Size number, the Cold Cranking Amperage (CCA) rating, and the Reserve Capacity (RC) rating or Ampere-Hours (AH) rating can be found on the original equipment battery label. Be certain that a replacement battery has the correct Group Size number, as well as CCA, and RC or AH ratings that equal or exceed the original equipment specification for the vehicle being serviced.

See the Battery Classifications and Ratings chart in Specifications at the back of this group for more information. Battery sizes and ratings are discussed in more detail below.

GROUP SIZE

The outside dimensions and terminal placement of the battery conform to standards established by the Battery Council International (BCI). Each battery is assigned a BCI Group Size number to help identify a correctly-sized replacement.

COLD CRANKING AMPERAGE

The Cold Cranking Amperage (CCA) rating specifies how much current (in amperes) the battery can deliver for thirty seconds at -18°C (0°F). Terminal voltage must not fall below 7.2 volts during or after the thirty second discharge period. The CCA required is generally higher as engine displacement increases, depending also upon the starter current draw requirements.

DESCRIPTION AND OPERATION (Continued)**RESERVE CAPACITY**

The Reserve Capacity (RC) rating specifies the time (in minutes) it takes for battery terminal voltage to fall below 10.5 volts, at a discharge rate of 25 amperes. RC is determined with the battery fully-charged at 26.7° C (80° F). This rating estimates how long the battery might last after a charging system failure, under minimum electrical load.

AMPERE-HOURS

The Ampere-Hours (AH) rating specifies the current (in amperes) that a battery can deliver steadily for twenty hours, with the voltage in the battery not falling below 10.5 volts. This rating is also sometimes referred to as the twenty-hour discharge rating.

BATTERY MOUNTING

The battery is mounted to a molded plastic tray located in the right front corner of the engine compartment. A U-nut is held in a formation on each side of the battery tray. A holddown strap fits across the top of the battery case and thermoguard. To secure the battery in the tray, a bolt passes through the holddown strap on each side of the battery, and is threaded into the U-nut on each side of the battery tray.

The battery tray is secured with three screws to the front wheelhouse extension panel, forward of the right front wheel. The tray is also secured to the right fender inner shield with two screws.

A vacuum reservoir for the vehicle speed control and heater-A/C systems is mounted to the underside of the battery tray. Refer to Group 8H - Vehicle Speed Control System or Group 24 - Heating and Air Conditioning for more information on the vacuum reservoir.

On some models, a hole in the bottom of the battery tray is fitted with a battery temperature sensor. Models without the battery temperature sensor have a plug fitted to this hole. Refer to Group 8C - Charging System for more information on the battery temperature sensor.

When installing a battery, be certain that the hold-down fasteners are tightened to the proper specifications. Improper holddown fastener tightness, whether too loose or too tight, can result in damage to the battery. See the Battery Removal and Installation procedures in this group for the correct holddown fastener tightness specifications.

DIAGNOSIS AND TESTING**BATTERY**

The battery must be completely charged and the top, posts, and terminal clamps should be properly cleaned before diagnostic procedures are performed. See the Battery Charging procedure in this group for more information.

WARNING:

- **IF THE BATTERY SHOWS SIGNS OF FREEZING, LEAKING, LOOSE POSTS, OR LOW ELECTROLYTE LEVEL, DO NOT TEST, ASSIST-BOOST, OR CHARGE. THE BATTERY MAY ARC INTERNALLY AND EXPLODE. PERSONAL INJURY AND/OR VEHICLE DAMAGE MAY RESULT.**

- **EXPLOSIVE HYDROGEN GAS FORMS IN AND AROUND THE BATTERY. DO NOT SMOKE, USE FLAME, OR CREATE SPARKS NEAR THE BATTERY. PERSONAL INJURY AND/OR VEHICLE DAMAGE MAY RESULT.**

- **THE BATTERY CONTAINS SULFURIC ACID, WHICH IS POISONOUS AND CAUSTIC. AVOID CONTACT WITH THE SKIN, EYES, OR CLOTHING. IN THE EVENT OF CONTACT, FLUSH WITH WATER AND CALL A PHYSICIAN IMMEDIATELY. KEEP OUT OF THE REACH OF CHILDREN.**

- **IF THE BATTERY IS EQUIPPED WITH REMOVABLE CELL CAPS, BE CERTAIN THAT EACH OF THE CELL CAPS IS IN PLACE AND TIGHT BEFORE THE BATTERY IS RETURNED TO SERVICE. PERSONAL INJURY AND/OR VEHICLE DAMAGE MAY RESULT FROM LOOSE OR MISSING CELL CAPS.**

The condition of a battery is determined by two criteria:

1. **State-Of-Charge** - This can be determined by viewing the built-in test indicator, by checking the specific gravity of the electrolyte (hydrometer test), or by checking the battery voltage (open-circuit voltage test).

2. **Cranking Capacity** - This can be determined by performing a battery load test, which measures the ability of the battery to supply high-amperage current.

First, determine the battery state-of-charge. This can be done in one of three ways. If the battery has a built-in test indicator, view the test indicator to determine the state-of-charge. If the battery has no test indicator, but has removable cell caps, perform the hydrometer test to determine the state-of-charge. If the cell caps are not removable, or a hydrometer is not available, perform the open-circuit voltage test to determine the state-of-charge.

DIAGNOSIS AND TESTING (Continued)

The battery must be charged before proceeding with a load test if:

- The built-in test indicator has a black or dark color visible.
- The temperature corrected specific gravity is less than 1.235.
- The open-circuit voltage is less than 12.4 volts.

A battery that will not accept a charge is faulty, and must be replaced. Further testing is not required. A fully-charged battery must be load tested to determine its cranking capacity. A battery that is fully-charged, but does not pass the load test, is faulty and must be replaced.

NOTE: Completely discharged batteries may take several hours to accept a charge. See Charging A Completely Discharged Battery in this group for more information.

A battery is fully-charged when:

- All cells are gassing freely during charging.
- A green color is visible in the sight glass of the built-in test indicator.
- Three corrected specific gravity tests, taken at one-hour intervals, indicate no increase in the specific gravity.
- Open-circuit voltage is 12.4 volts or greater.

DIAGNOSIS AND TESTING (Continued)

Battery Diagnosis		
Condition	Possible Causes	Correction
<p>The battery seems weak or dead when attempting to start the engine.</p>	<ol style="list-style-type: none"> 1. The battery has an incorrect size or rating for this vehicle. 2. The battery is physically damaged. 3. The battery terminal connections are loose or corroded. 4. The battery is discharged. 5. The electrical system is faulty. 6. The battery is faulty. 7. The starting system is faulty. 8. The charging system is faulty. 	<ol style="list-style-type: none"> 1. See Specifications in this group. Replace the incorrect battery with the correct battery, if required. 2. Inspect the battery for loose terminal posts or a cracked and leaking case. Replace the battery, if damaged. 3. See the Voltage Drop Test in this group. Clean and tighten the battery terminal connections, if required. 4. See the Test Indicator, the Hydrometer Test, or the Open-Circuit Voltage Test in this group to determine the battery state-of-charge. Charge the battery, if required. 5. See the Ignition-Off Draw Test in this group. Repair the electrical system, if required. 6. See the Load Test in this group to determine the battery condition. Replace the battery, if required. 7. Refer to Group 8B - Starting Systems for more information. Repair the starting system, if required. 8. Refer to Group 8C - Charging Systems for more information. Repair the charging system, if required.
<p>The battery state-of-charge cannot be maintained.</p>	<ol style="list-style-type: none"> 1. The battery has an incorrect size or rating for this vehicle. 2. The battery terminal connections are loose or corroded. 3. The generator drive belt is loose or worn. 4. The electrical system is faulty. 5. The battery is faulty. 6. The starting system is faulty. 7. The charging system is faulty. 8. Electrical loads exceed the output of the charging system. 9. Slow driving or prolonged idling with high-amperage draw systems in use. 	<ol style="list-style-type: none"> 1. See Specifications in this group. Replace the incorrect battery with the correct battery, if required. 2. See the Voltage Drop Test in this group. Clean and tighten the battery terminal connections, if required. 3. Refer to Group 7 - Cooling Systems for more information. Replace or adjust the generator drive belt, if required. 4. See the Ignition-Off Draw Test in this group. Repair the electrical system, if required. 5. See the Load Test in this group to determine the battery condition. Replace the battery, if required. 6. Check whether the starting system is performing to specifications. Refer to Group 8B - Starting Systems for more information. Repair the starting system, if required. 7. Refer to Group 8C - Charging Systems for more information. Repair the charging system, if required. 8. Inspect the vehicle for aftermarket electrical equipment which might cause excessive electrical loads. 9. Advise the vehicle operator, as required.
<p>The battery will not accept a charge.</p>	<ol style="list-style-type: none"> 1. The battery is faulty. 	<ol style="list-style-type: none"> 1. See Battery Charging in this group. Replace the faulty battery, if required.

DIAGNOSIS AND TESTING (Continued)

ABNORMAL BATTERY DISCHARGING

Any of the following conditions can result in abnormal battery discharging:

1. Corroded or loose battery posts and terminal clamps.
2. A loose or worn generator drive belt.
3. Electrical loads that exceed the output of the charging system. This can be due to equipment installed after manufacture, or repeated short trip use.
4. Slow driving speeds (heavy traffic conditions) or prolonged idling, with high-amperage draw systems in use.
5. A faulty circuit or component causing excessive ignition-off draw. See the Ignition-Off Draw Test procedure in this group for more information.
6. A faulty or incorrect charging system component. Refer to Group 8C - Charging System for more information.
7. A faulty or incorrect battery.

BUILT-IN TEST INDICATOR

A test indicator (hydrometer) built into the top of the battery case provides visual information for battery testing (Fig. 2). Like a hydrometer, the built-in test indicator measures the specific gravity of the electrolyte. The test indicator reveals the battery state-of-charge; however, it will not reveal the cranking capacity of the battery. A load test must be performed to determine the battery cranking capacity. See the Load Test procedure in this group for more information.

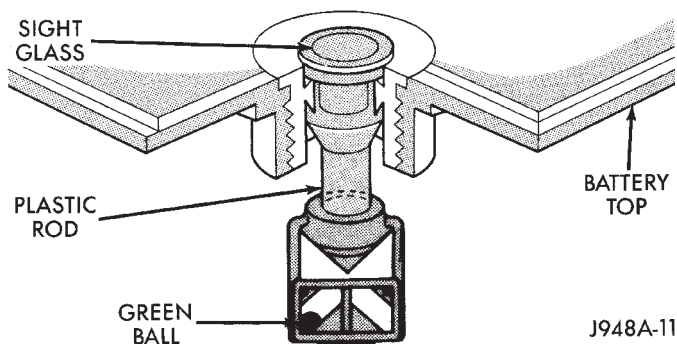


Fig. 2 Built-In Test Indicator

WARNING:

• IF THE BATTERY SHOWS SIGNS OF FREEZING, LEAKING, LOOSE POSTS, OR LOW ELECTROLYTE LEVEL, DO NOT TEST, ASSIST-BOOST, OR CHARGE. THE BATTERY MAY ARC INTERNALLY AND EXPLODE. PERSONAL INJURY AND/OR VEHICLE DAMAGE MAY RESULT.

• EXPLOSIVE HYDROGEN GAS FORMS IN AND AROUND THE BATTERY. DO NOT SMOKE, USE FLAME, OR CREATE SPARKS NEAR THE BATTERY.

PERSONAL INJURY AND/OR VEHICLE DAMAGE MAY RESULT.

• THE BATTERY CONTAINS SULFURIC ACID, WHICH IS POISONOUS AND CAUSTIC. AVOID CONTACT WITH THE SKIN, EYES, OR CLOTHING. IN THE EVENT OF CONTACT, FLUSH WITH WATER AND CALL A PHYSICIAN IMMEDIATELY. KEEP OUT OF THE REACH OF CHILDREN.

• IF THE BATTERY IS EQUIPPED WITH REMOVABLE CELL CAPS, BE CERTAIN THAT EACH OF THE CELL CAPS IS IN PLACE AND TIGHT BEFORE THE BATTERY IS RETURNED TO SERVICE. PERSONAL INJURY AND/OR VEHICLE DAMAGE MAY RESULT FROM LOOSE OR MISSING CELL CAPS.

Before testing, visually inspect the battery for any damage (a cracked case or cover, loose posts, etc.) that would cause the battery to be faulty. In order to obtain correct indications from the built-in test indicator, it is important that the battery be level and have a clean sight glass. Additional light may be required to view the indicator. **Do not use open flame as a source of additional light.**

To read the built-in test indicator, look into the sight glass and note the color of the indicator (Fig. 3). Refer to the following description, as the color indicates:

• **Green** - indicates 75% to 100% state-of-charge. The battery is adequately charged for further testing or return to use. If the vehicle will not crank for a minimum of fifteen seconds with a fully-charged battery, perform the Load Test procedure as described in this group.

• **Black or Dark** - indicates 0% to 75% state-of-charge. The battery is inadequately charged and must be charged until a green indication is visible in the sight glass (12.4 volts or more), before the battery is tested further or returned to service. See the Battery Charging procedure in this group for more information. Also see Abnormal Battery Discharging in this group for possible causes of the discharged condition.

• **Clear or Bright** - indicates a low electrolyte level. The electrolyte level in the battery is below the test indicator. A maintenance-free battery with non-removable cell caps must be replaced if the electrolyte level is low. Water must be added to a low-maintenance battery with removable cell caps before it is charged. See the Battery Charging procedure in this group for more information. A low electrolyte level may be caused by an overcharging condition. Refer to Group 8C - Charging System to diagnose an overcharging condition.

DIAGNOSIS AND TESTING (Continued)

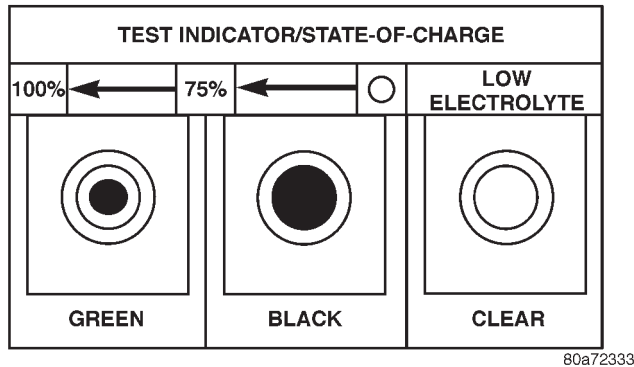


Fig. 3 Built-In Test Indicator Sight Glass

HYDROMETER TEST

The hydrometer test reveals the battery state-of-charge by measuring the specific gravity of the electrolyte. This test cannot be performed on maintenance-free batteries with non-removable cell caps. If the battery has non-removable cell caps, see the Built-In Test Indicator or the Open-Circuit Voltage Test procedures in this group.

Specific gravity is a comparison of the density of the electrolyte to the density of pure water. Pure water has a specific gravity of 1.000, and sulfuric acid has a specific gravity of 1.835. Sulfuric acid makes up approximately 35% of the electrolyte by weight, or 24% by volume.

In a fully-charged battery the electrolyte will have a temperature-corrected specific gravity of 1.260 to 1.290. However, a specific gravity of 1.235 or above is satisfactory for battery load testing and/or return to service.

WARNING:

- IF THE BATTERY SHOWS SIGNS OF FREEZING, LEAKING, LOOSE POSTS, OR LOW ELECTROLYTE LEVEL, DO NOT TEST, ASSIST-BOOST, OR CHARGE. THE BATTERY MAY ARC INTERNALLY AND EXPLODE. PERSONAL INJURY AND/OR VEHICLE DAMAGE MAY RESULT.

- EXPLOSIVE HYDROGEN GAS FORMS IN AND AROUND THE BATTERY. DO NOT SMOKE, USE FLAME, OR CREATE SPARKS NEAR THE BATTERY. PERSONAL INJURY AND/OR VEHICLE DAMAGE MAY RESULT.

- THE BATTERY CONTAINS SULFURIC ACID, WHICH IS POISONOUS AND CAUSTIC. AVOID CONTACT WITH THE SKIN, EYES, OR CLOTHING. IN THE EVENT OF CONTACT, FLUSH WITH WATER AND CALL A PHYSICIAN IMMEDIATELY. KEEP OUT OF THE REACH OF CHILDREN.

- IF THE BATTERY IS EQUIPPED WITH REMOVABLE CELL CAPS, BE CERTAIN THAT EACH OF THE CELL CAPS IS IN PLACE AND TIGHT BEFORE THE BATTERY IS RETURNED TO SERVICE. PER-

SONAL INJURY AND/OR VEHICLE DAMAGE MAY RESULT FROM LOOSE OR MISSING CELL CAPS.

Before testing, visually inspect the battery for any damage (a cracked case or cover, loose posts, etc.) that would cause the battery to be faulty. Then remove the cell caps and check the electrolyte level. Add distilled water if the electrolyte level is below the top of the battery plates.

Refer to the instructions supplied with the hydrometer for recommendations on the correct use of the hydrometer. Remove only enough electrolyte from the battery cell so that the float is off the bottom of the hydrometer barrel with pressure on the bulb released.

CAUTION: Exercise care when inserting the tip of the hydrometer into a cell to avoid damaging the plate separators. Damaged plate separators can cause early battery failure.

To read the hydrometer correctly, hold it with the top surface of the electrolyte at eye level (Fig. 4). Hydrometer floats are generally calibrated to indicate the specific gravity correctly only at 26.7° C (80° F). When testing the specific gravity at any other temperature, a correction factor is required.

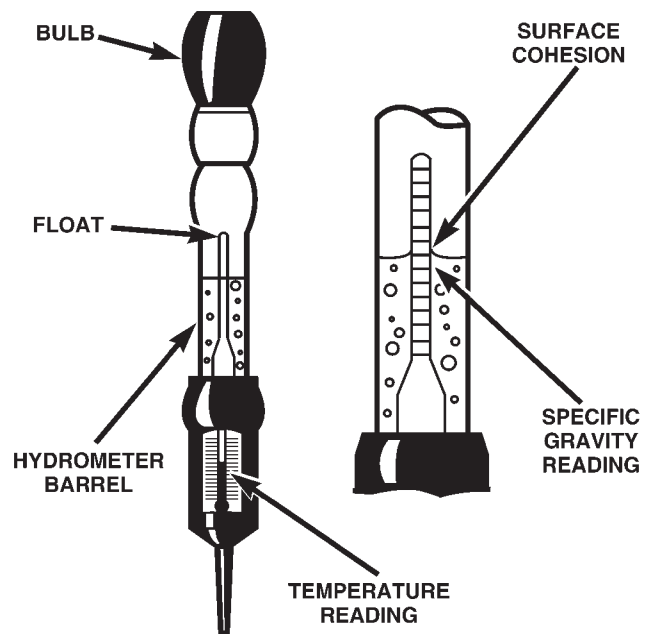


Fig. 4 Hydrometer - Typical

The correction factor is approximately a specific gravity value of 0.004, referred to as four points of specific gravity. For each 5.5° C above 26.7° C (10° F above 80° F), add four points. For each 5.5° C below 26.7° C (10° F below 80° F), subtract four points. Always correct the specific gravity for temperature

DIAGNOSIS AND TESTING (Continued)

variation. Test the specific gravity of the electrolyte in each battery cell.

EXAMPLE: A battery is tested at -12.2°C (10°F) and has a specific gravity of 1.240. Determine the actual specific gravity as follows:

(1) Determine the number of degrees above or below 26.7°C (80°F):

$$26.6^{\circ}\text{C} - -12.2^{\circ}\text{C} = 38.8^{\circ}\text{C} \quad (80^{\circ}\text{F} - 10^{\circ}\text{F} = 70^{\circ}\text{F})$$

(2) Divide the result from Step 1 by 5.5 (10):

$$38.8^{\circ}\text{C} \div 5.5 = 7 \quad (70^{\circ}\text{F} \div 10 = 7)$$

(3) Multiply the result from Step 2 by the temperature correction factor (0.004):

$$7 \times 0.004 = 0.028$$

(4) The temperature at testing was below 26.7°C (80°F); therefore, the temperature correction factor is subtracted:

$$1.240 - 0.028 = 1.212$$

The corrected specific gravity of the battery in this example is 1.212.

If the specific gravity of all cells is above 1.235, but the variation between cells is more than fifty points (0.050), the battery should be replaced. If the specific gravity of one or more cells is less than 1.235, charge the battery at a rate of approximately five amperes.

Continue charging the battery until three consecutive specific gravity tests, taken at one-hour intervals, are constant. If the cell specific gravity variation is more than fifty points (0.050) at the end of the charge period, replace the battery.

When the specific gravity of all cells is above 1.235, and the cell variation is less than fifty points (0.050), the battery may be load tested to determine its cranking capacity. See the Load Test procedure in this group for more information.

OPEN-CIRCUIT VOLTAGE TEST

A battery open-circuit voltage (no load) test will show the state-of-charge of a battery. This test can be used in place of the hydrometer test when a hydrometer is not available, or for maintenance-free batteries with non-removable cell caps.

WARNING:

- IF THE BATTERY SHOWS SIGNS OF FREEZING, LEAKING, LOOSE POSTS, OR LOW ELECTROLYTE LEVEL, DO NOT TEST, ASSIST-BOOST, OR CHARGE. THE BATTERY MAY ARC INTERNALLY AND EXPLODE. PERSONAL INJURY AND/OR VEHICLE DAMAGE MAY RESULT.

- EXPLOSIVE HYDROGEN GAS FORMS IN AND AROUND THE BATTERY. DO NOT SMOKE, USE FLAME, OR CREATE SPARKS NEAR THE BATTERY. PERSONAL INJURY AND/OR VEHICLE DAMAGE MAY RESULT.

- THE BATTERY CONTAINS SULFURIC ACID, WHICH IS POISONOUS AND CAUSTIC. AVOID CONTACT WITH THE SKIN, EYES, OR CLOTHING. IN THE EVENT OF CONTACT, FLUSH WITH WATER AND CALL A PHYSICIAN IMMEDIATELY. KEEP OUT OF THE REACH OF CHILDREN.

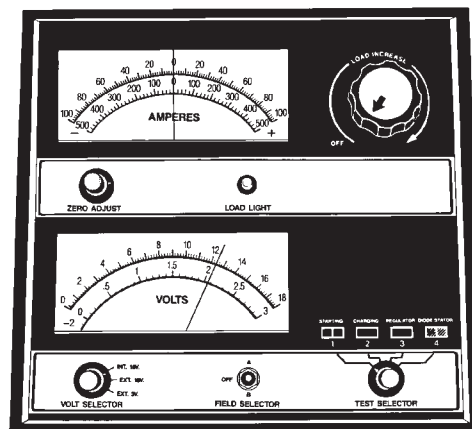
- IF THE BATTERY IS EQUIPPED WITH REMOVABLE CELL CAPS, BE CERTAIN THAT EACH OF THE CELL CAPS IS IN PLACE AND TIGHT BEFORE THE BATTERY IS RETURNED TO SERVICE. PERSONAL INJURY AND/OR VEHICLE DAMAGE MAY RESULT FROM LOOSE OR MISSING CELL CAPS.

Before proceeding with this test, completely charge the battery as described in the Battery Charging procedure in this group.

(1) Before measuring the open-circuit voltage, the surface charge must be removed from the battery. Turn on the head lamps for fifteen seconds, then allow up to five minutes for the battery voltage to stabilize.

(2) Disconnect and isolate both battery cables, negative cable first.

(3) Using a voltmeter connected to the battery posts (refer to the instructions provided with the voltmeter), measure the open-circuit voltage (Fig. 5).



898A-7

Fig. 5 Testing Open-Circuit Voltage - Typical

See the Open-Circuit Voltage chart. This voltage reading will indicate the battery state-of-charge, but will not reveal its cranking capacity. If a battery has an open-circuit voltage reading of 12.4 volts or greater, it may be load tested to reveal its cranking capacity. See the Load Test procedure in this group for more information.

DIAGNOSIS AND TESTING (Continued)

Open Circuit Voltage	
Open Circuit Volts	Charge Percentage
11.7 volts or less	0%
12.0 volts	25%
12.2 volts	50%
12.4 volts	75%
12.6 volts or more	100%

LOAD TEST

A battery load test will verify the battery cranking capacity. The test is based on the Cold Cranking Amperage (CCA) rating of the battery. Refer to the battery label, or see the Battery Classifications and Ratings chart in Specifications at the back of this group for the CCA rating of the factory-installed battery.

WARNING:

- IF THE BATTERY SHOWS SIGNS OF FREEZING, LEAKING, LOOSE POSTS, OR LOW ELECTROLYTE LEVEL, DO NOT TEST, ASSIST-BOOST, OR CHARGE. THE BATTERY MAY ARC INTERNALLY AND EXPLODE. PERSONAL INJURY AND/OR VEHICLE DAMAGE MAY RESULT.

- EXPLOSIVE HYDROGEN GAS FORMS IN AND AROUND THE BATTERY. DO NOT SMOKE, USE FLAME, OR CREATE SPARKS NEAR THE BATTERY. PERSONAL INJURY AND/OR VEHICLE DAMAGE MAY RESULT.

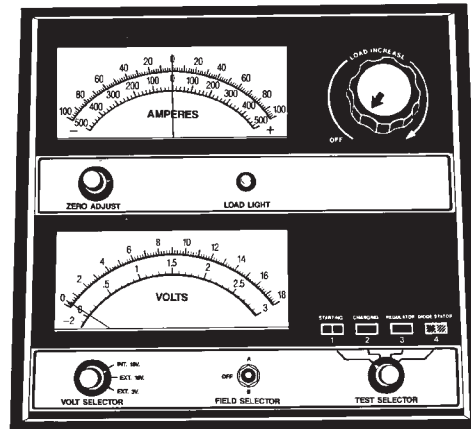
- THE BATTERY CONTAINS SULFURIC ACID, WHICH IS POISONOUS AND CAUSTIC. AVOID CONTACT WITH THE SKIN, EYES, OR CLOTHING. IN THE EVENT OF CONTACT, FLUSH WITH WATER AND CALL A PHYSICIAN IMMEDIATELY. KEEP OUT OF THE REACH OF CHILDREN.

- IF THE BATTERY IS EQUIPPED WITH REMOVABLE CELL CAPS, BE CERTAIN THAT EACH OF THE CELL CAPS IS IN PLACE AND TIGHT BEFORE THE BATTERY IS RETURNED TO SERVICE. PERSONAL INJURY AND/OR VEHICLE DAMAGE MAY RESULT FROM LOOSE OR MISSING CELL CAPS.

Before proceeding with this test, completely charge the battery as described in the Battery Charging procedure in this group.

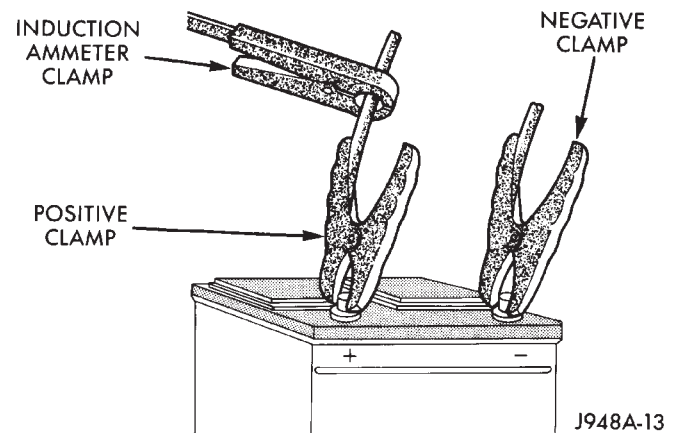
(1) Disconnect and isolate both battery cables, negative cable first. The battery top and posts should be clean.

(2) Connect a suitable volt-ammeter-load tester (Fig. 6) to the battery posts (Fig. 7). Refer to the operating instructions provided with the tester being used. Check the open-circuit voltage (no load) of the battery. Open-circuit voltage must be 12.4 volts or greater.



898A-8

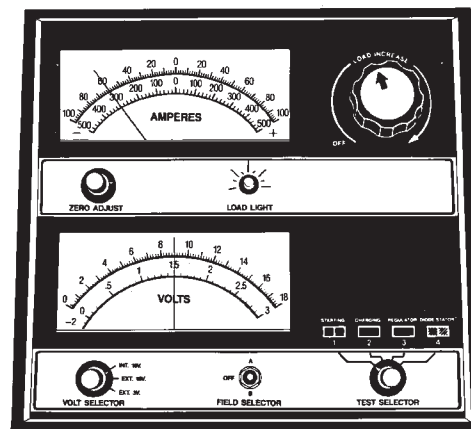
Fig. 6 Volt-Ammeter-Load Tester - Typical



J948A-13

Fig. 7 Volt-Ammeter-Load Tester Connections - Typical

(3) Rotate the load control knob (carbon pile rheostat) to apply a 300 ampere load to the battery for fifteen seconds, then return the control knob to the Off position (Fig. 8). This will remove the surface charge from the battery.



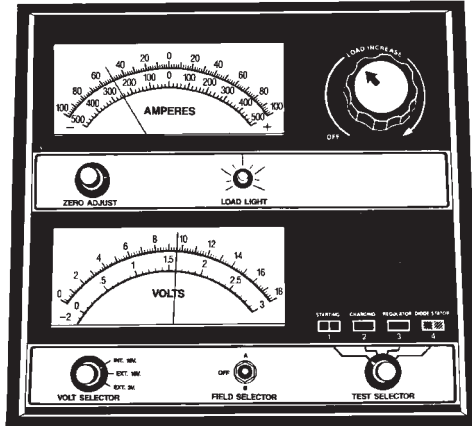
898A-10

Fig. 8 Remove Surface Charge from Battery - Typical

DIAGNOSIS AND TESTING (Continued)

(4) Allow the battery to stabilize to open-circuit voltage. It may take up to five minutes for the battery voltage to stabilize.

(5) Rotate the load control knob to maintain a load equal to 50% of the CCA rating of the battery (Fig. 9). After fifteen seconds, record the loaded voltage reading, then return the load control knob to the Off position.



898A-11

Fig. 9 Load 50% CCA Rating - Note Voltage - Typical

(6) The voltage drop will vary with the battery temperature at the time of the load test. The battery temperature can be estimated by using the ambient temperature during the past several hours. If the battery has been charged, boosted, or loaded a few minutes prior to the test, the battery will be somewhat warmer. See the Load Test Temperature chart for the proper loaded voltage reading.

Load Test Temperature		
Minimum Voltage	Temperature	
	°F	°C
9.6 volts	70° and above	21° and above
9.5 volts	60°	16°
9.4 volts	50°	10°
9.3 volts	40°	4°
9.1 volts	30°	-1°
8.9 volts	20°	-7°
8.7 volts	10°	-12°
8.5 volts	0°	-18°

(7) If the voltmeter reading falls below 9.6 volts, at a minimum battery temperature of 21° C (70° F), the battery is faulty and must be replaced.

IGNITION-OFF DRAW TEST

Ignition-Off Draw (IOD) refers to power being drained from the battery with the ignition switch in the Off position. A normal vehicle electrical system will draw from five to thirty milliamperes (0.005 to 0.030 ampere) with the ignition switch in the Off position, and all non-ignition controlled circuits in proper working order. The thirty milliamperes are needed to enable the memory functions for the Powertrain Control Module (PCM), digital clock, electronically tuned radio, and other modules which may vary with the vehicle equipment.

A vehicle that has not been operated for approximately twenty days, may discharge the battery to an inadequate level. When a vehicle will not be used for twenty days or more (stored), remove the IOD fuse from the Power Distribution Center (PDC). This will reduce battery discharging.

Excessive IOD can be caused by:

- Electrical items left on
- Faulty or improperly adjusted switches
- Faulty or shorted electronic modules and components
- An internally shorted generator
- Intermittent shorts in the wiring.

If the IOD is over thirty milliamperes, the problem must be found and corrected before replacing a battery. In most cases, the battery can be charged and returned to service after the excessive IOD condition has been corrected.

DIAGNOSIS

(1) Verify that all electrical accessories are off. Turn off all lamps, remove the ignition key, and close all doors. If the vehicle is equipped with a illuminated entry system or electronically tuned radio, allow the electronic timer function of these systems to automatically shut off (time out). This may take up to three minutes.

(2) Determine that the underhood lamp is operating properly, then unplug the lamp wire harness connector or remove the lamp bulb.

(3) Disconnect the battery negative cable.

(4) Set an electronic digital multi-meter to its highest amperage scale. Connect the multi-meter between the disconnected battery negative cable clamp and the battery negative terminal post. Make sure that the doors remain closed so that the illuminated entry system is not activated. The multi-meter amperage reading may remain high for up to three minutes, or may not give any reading at all while set in the highest amperage scale, depending upon the electrical equipment on the vehicle. The multi-meter leads must be securely clamped to the battery negative cable clamp and the battery negative terminal post. If continuity between the battery negative ter-

DIAGNOSIS AND TESTING (Continued)

minal post and the negative cable clamp is lost during any part of the IOD test, the electronic timer function will be activated and all of the tests will have to be repeated.

(5) After about three minutes, the high-amperage IOD reading on the multi-meter should become very low or nonexistent, depending upon the electrical equipment on the vehicle. If the amperage reading remains high, remove each fuse or circuit breaker (refer to Group 8W - Wiring Diagrams for more information) until the amperage reading becomes very low, or nonexistent. This will isolate each circuit and identify the source of the high-amperage IOD. If the amperage reading remains high after disconnecting each fuse and circuit breaker, unplug the wire harness connector from the generator. If the amperage reading now becomes very low or nonexistent, refer to Group 8C - Charging System to diagnose the faulty charging system. After the high-amperage IOD has been corrected, switch the multi-meter to progressively lower amperage scales and, if necessary, repeat the fuse and circuit breaker removal process to identify and correct the sources of excessive IOD. It is now safe to select the lowest milliampere scale of the multi-meter to check the low-amperage IOD.

CAUTION: Do not open any doors, or turn on any electrical accessories with the lowest milliampere scale selected, or the multi-meter may be damaged.

(6) Observe the multi-meter reading. The low-amperage IOD should not exceed thirty milliamperes (0.030 ampere). If the draw exceeds thirty milliamperes, isolate each circuit by removing the circuit breakers and fuses. The multi-meter reading will drop to within the acceptable limit when the source of the excessive draw is disconnected. Repair this circuit as required; whether a wiring short, incorrect switch adjustment, or a component failure is at fault.

VOLTAGE DROP TEST

The voltage drop test will determine if there is excessive resistance in the battery terminal connections or the battery cables. When performing these tests, it is important to remember that the voltage drop is giving an indication of the resistance between the two points at which the voltmeter probes are attached.

Example: When testing the resistance of the battery positive cable, touch the voltmeter leads to the battery positive cable clamp and the cable connector

at the starter solenoid. If you probe the battery positive terminal post and the cable connector at the starter solenoid, you are reading the combined voltage drop in the battery positive cable clamp-to-terminal post connection and the battery positive cable.

WARNING:

- IF THE BATTERY SHOWS SIGNS OF FREEZING, LEAKING, LOOSE POSTS, OR LOW ELECTROLYTE LEVEL, DO NOT TEST, ASSIST-BOOST, OR CHARGE. THE BATTERY MAY ARC INTERNALLY AND EXPLODE. PERSONAL INJURY AND/OR VEHICLE DAMAGE MAY RESULT.

- EXPLOSIVE HYDROGEN GAS FORMS IN AND AROUND THE BATTERY. DO NOT SMOKE, USE FLAME, OR CREATE SPARKS NEAR THE BATTERY. PERSONAL INJURY AND/OR VEHICLE DAMAGE MAY RESULT.

- THE BATTERY CONTAINS SULFURIC ACID, WHICH IS POISONOUS AND CAUSTIC. AVOID CONTACT WITH THE SKIN, EYES, OR CLOTHING. IN THE EVENT OF CONTACT, FLUSH WITH WATER AND CALL A PHYSICIAN IMMEDIATELY. KEEP OUT OF THE REACH OF CHILDREN.

- IF THE BATTERY IS EQUIPPED WITH REMOVABLE CELL CAPS, BE CERTAIN THAT EACH OF THE CELL CAPS IS IN PLACE AND TIGHT BEFORE THE BATTERY IS RETURNED TO SERVICE. PERSONAL INJURY AND/OR VEHICLE DAMAGE MAY RESULT FROM LOOSE OR MISSING CELL CAPS.

The following operation will require a voltmeter accurate to 1/10 (0.10) volt. Before performing the tests, be certain the following procedures are accomplished:

- Battery is fully-charged as described in this group.

- Fully engage the parking brake.

- If the vehicle is equipped with an automatic transmission, place the gearshift selector lever in the Park position. If the vehicle is equipped with a manual transmission, place the gearshift selector lever in the Neutral position and fully depress the clutch pedal.

- Unplug the Automatic ShutDown (ASD) relay to prevent the engine from starting. The ASD relay is located in the Power Distribution Center (PDC). Refer to the PDC label for ASD relay identification and location.

DIAGNOSIS AND TESTING (Continued)

(1) Connect the positive lead of the voltmeter to the battery negative terminal post. Connect the negative lead of the voltmeter to the battery negative cable clamp (Fig. 10). Rotate and hold the ignition switch in the Start position. Observe the voltmeter. If voltage is detected, correct the poor contact between the cable clamp and the terminal post.

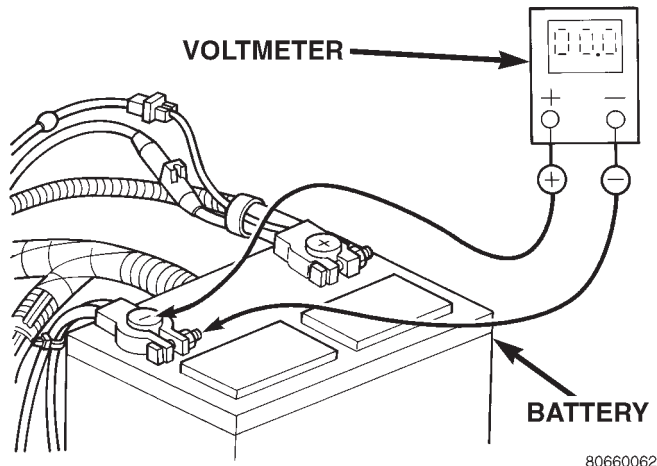


Fig. 10 Test Battery Negative Connection Resistance - Typical

(2) Connect the positive lead of the voltmeter to the battery positive terminal post. Connect the negative lead of the voltmeter to the battery positive cable clamp (Fig. 11). Rotate and hold the ignition switch in the Start position. Observe the voltmeter. If voltage is detected, correct the poor contact between the cable clamp and the terminal post.

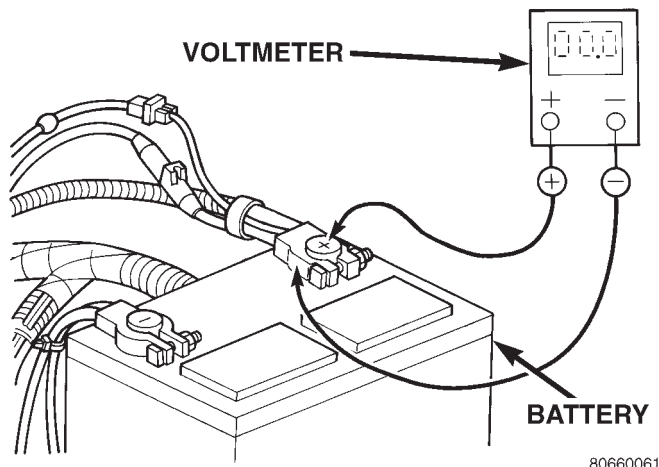


Fig. 11 Test Battery Positive Connection Resistance - Typical

(3) Connect the voltmeter to measure between the battery positive terminal post and the starter solenoid battery terminal stud (Fig. 12). Rotate and hold the ignition switch in the Start position. Observe the voltmeter. If the reading is above 0.2 volt, clean and

tighten the battery cable connection at the solenoid. Repeat the test. If the reading is still above 0.2 volt, replace the faulty battery positive cable.

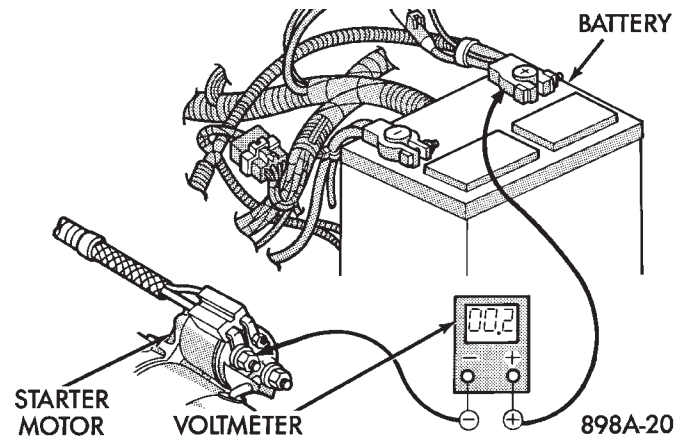


Fig. 12 Test Battery Positive Cable Resistance - Typical

(4) Connect the voltmeter to measure between the battery negative terminal post and a good clean ground on the engine block (Fig. 13). Rotate and hold the ignition switch in the Start position. Observe the voltmeter. If the reading is above 0.2 volt, clean and tighten the battery negative cable attachment on the engine block. Repeat the test. If the reading is still above 0.2 volt, replace the faulty battery negative cable.

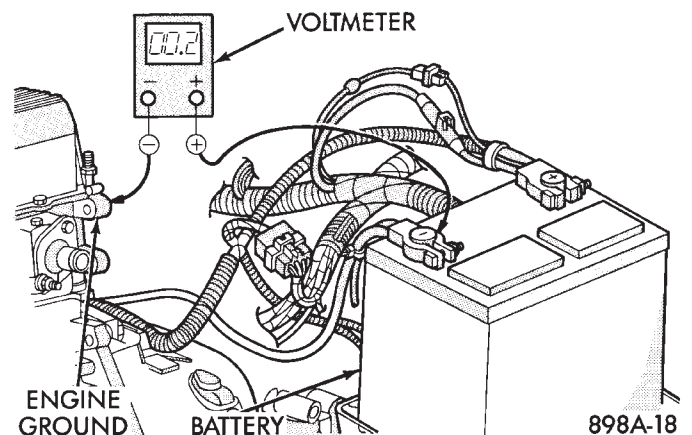


Fig. 13 Test Ground Circuit Resistance - Typical

SERVICE PROCEDURES**BATTERY CHARGING**

A battery is fully-charged when:

- All cells are gassing freely during battery charging.
- A green color is visible in the sight glass of the built-in test indicator.
- Three corrected specific gravity tests, taken at one-hour intervals, indicate no increase in the specific gravity.
- Open-circuit voltage is 12.4 volts or above.

SERVICE PROCEDURES (Continued)

WARNING:

- IF THE BATTERY SHOWS SIGNS OF FREEZING, LEAKING, LOOSE POSTS, OR LOW ELECTROLYTE LEVEL, DO NOT TEST, ASSIST-BOOST, OR CHARGE. THE BATTERY MAY ARC INTERNALLY AND EXPLODE. PERSONAL INJURY AND/OR VEHICLE DAMAGE MAY RESULT.

- EXPLOSIVE HYDROGEN GAS FORMS IN AND AROUND THE BATTERY. DO NOT SMOKE, USE FLAME, OR CREATE SPARKS NEAR THE BATTERY. PERSONAL INJURY AND/OR VEHICLE DAMAGE MAY RESULT.

- THE BATTERY CONTAINS SULFURIC ACID, WHICH IS POISONOUS AND CAUSTIC. AVOID CONTACT WITH THE SKIN, EYES, OR CLOTHING. IN THE EVENT OF CONTACT, FLUSH WITH WATER AND CALL A PHYSICIAN IMMEDIATELY. KEEP OUT OF THE REACH OF CHILDREN.

- IF THE BATTERY IS EQUIPPED WITH REMOVABLE CELL CAPS, BE CERTAIN THAT EACH OF THE CELL CAPS IS IN PLACE AND TIGHT BEFORE THE BATTERY IS RETURNED TO SERVICE. PERSONAL INJURY AND/OR VEHICLE DAMAGE MAY RESULT FROM LOOSE OR MISSING CELL CAPS.

CAUTION:

- Always disconnect and isolate the battery negative cable before charging a battery. Do not exceed sixteen volts while charging a battery. Damage to the vehicle electrical system components may result.

- Battery electrolyte will bubble inside the battery case during normal battery charging. Electrolyte boiling or being discharged from the battery vents indicates a battery overcharging condition. Immediately reduce the charging rate or turn off the charger to evaluate the battery condition. Damage to the battery may result from overcharging.

- The battery should not be hot to the touch. If the battery feels hot to the touch, turn off the charger and let the battery cool before continuing the charging operation. Damage to the battery may result.

Some battery chargers are equipped with polarity-sensing circuitry. This circuitry protects the charger and/or the battery from being damaged if they are improperly connected. If the battery state-of-charge is too low for the polarity-sensing circuitry to detect, the charger will not operate. This makes it appear that the battery will not accept charging current. Refer to the instructions provided with the battery charger to bypass the polarity-sensing circuitry.

After the battery has been charged to 12.4 volts or greater, perform a load test to determine the battery cranking capacity. If the battery will endure a load

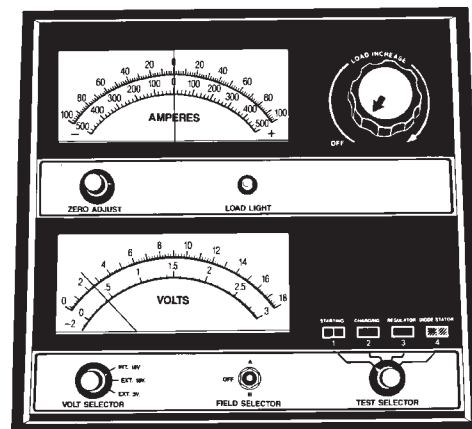
test, return the battery to use. If the battery will not endure a load test, it is faulty and must be replaced.

Clean and inspect the battery holddowns, tray, terminals, posts, and top before completing service. See the Battery Removal and Installation procedures in this group for more information.

CHARGING A COMPLETELY DISCHARGED BATTERY

The following procedure should be used to recharge a completely discharged battery. Unless this procedure is properly followed, a good battery may be needlessly replaced.

(1) Measure the voltage at the battery posts with a voltmeter, accurate to 1/10 (0.10) volt (Fig. 14). If the reading is below ten volts, the charge current will be low. It could take some time before the battery accepts a current greater than a few milliamperes. Such low current may not be detectable on the ammeters built into many chargers.



898A-12

Fig. 14 Voltmeter Accurate to 1/10 Volt Connected - Typical

(2) Disconnect and isolate the battery negative cable. Connect the battery charger leads. Some battery chargers are equipped with polarity-sensing circuitry. This circuitry protects the charger and/or the battery from being damaged if they are improperly connected. If the battery state-of-charge is too low for the polarity-sensing circuitry to detect, the charger will not operate. This makes it appear that the battery will not accept charging current. Refer to the instructions provided with the battery charger to bypass the polarity-sensing circuitry.

(3) Battery chargers vary in the amount of voltage and current they provide. The amount of time required for a battery to accept measurable charger current at various voltages is shown in the Charge Rate chart. If the charge current is still not measurable at the end of the charging time, the battery is faulty and must be replaced. If the charge current is measurable during the charging time, the battery

SERVICE PROCEDURES (Continued)

may be good and the charging should be completed in the normal manner.

Charge Rate	
Voltage	Hours
16.0 volts maximum	up to 4 hours
14.0 to 15.9 volts	up to 8 hours
13.9 volts or less	up to 16 hours

CHARGING TIME REQUIRED

The time required to charge a battery will vary, depending upon the following factors:

- **Battery Capacity** - A completely discharged heavy-duty battery requires twice the charging time of a small capacity battery.

- **Temperature** - A longer time will be needed to charge a battery at -18° C (0° F) than at 27° C (80° F). When a fast charger is connected to a cold battery, the current accepted by the battery will be very low at first. As the battery warms, it will accept a higher charging current rate (amperage).

- **Charger Capacity** - A charger that supplies only five amperes will require a longer charging time. A charger that supplies twenty amperes or more will require a shorter charging time.

- **State-Of-Charge** - A completely discharged battery requires more charging time than a partially discharged battery. Electrolyte is nearly pure water in a completely discharged battery. At first, the charging current (amperage) will be low. As the battery charges, the specific gravity of the electrolyte will gradually rise.

WARNING: NEVER EXCEED TWENTY AMPERES WHEN CHARGING A COLD (-1° C/30° F) BATTERY. THE BATTERY MAY ARC INTERNALLY AND EXPLODE. PERSONAL INJURY AND/OR VEHICLE DAMAGE MAY RESULT.

Battery Charging Timetable			
Charging Amperage	5 Amperes	10 Amperes	20 Amperes
Open Circuit Voltage	Hours Charging at 21°C (70°F)		
12.25 to 12.39	6 hours	3 hours	1.5 hours
12.00 to 12.24	8 hours	4 hours	2 hours
11.95 to 11.99	12 hours	6 hours	3 hours
10.00 to 11.94	14 hours	7 hours	3.5 hours
less than 10.00	See Charging Completely Discharged Battery		

REMOVAL AND INSTALLATION

BATTERY

(1) Turn the ignition switch to the Off position. Make sure all electrical accessories are turned off.

(2) Loosen the cable terminal clamps and disconnect both battery cables, negative cable first. If necessary, use a puller to remove the terminal clamps from the battery posts (Fig. 15).

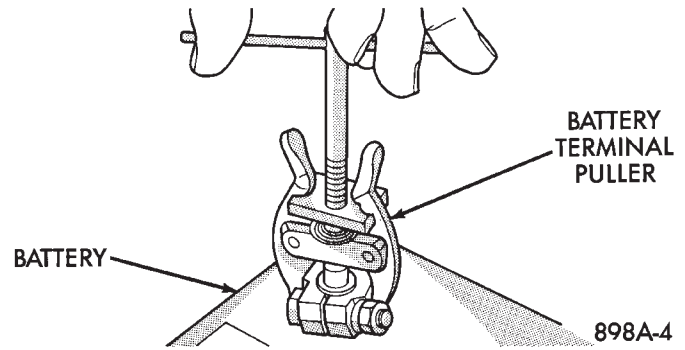


Fig. 15 Remove Battery Terminal Clamp - Typical

(3) Inspect the cable terminal clamps for corrosion and damage. Remove any corrosion using a wire brush or a post and terminal cleaning tool, and a sodium bicarbonate (baking soda) and warm water cleaning solution (Fig. 16). Replace any cable that has damaged or deformed terminal clamps.

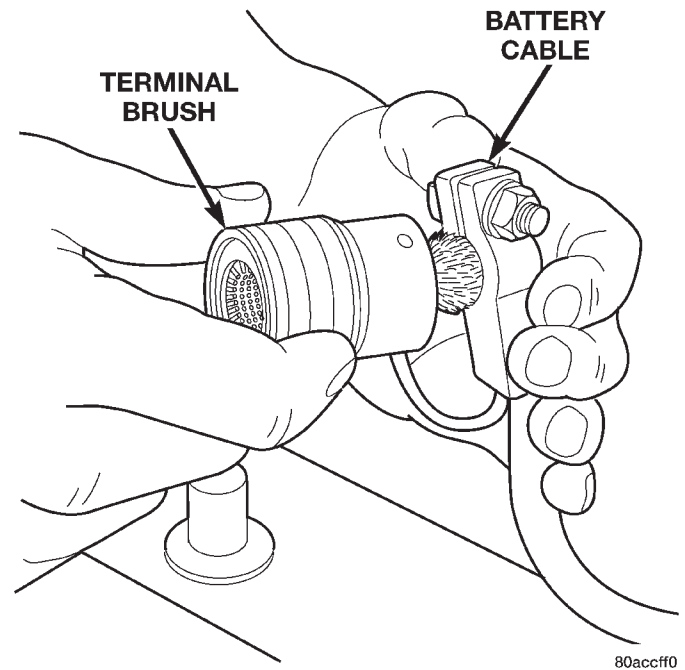


Fig. 16 Clean Battery Cable Terminal Clamp - Typical

REMOVAL AND INSTALLATION (Continued)

WARNING: WEAR A SUITABLE PAIR OF RUBBER GLOVES (NOT THE HOUSEHOLD TYPE) WHEN REMOVING A BATTERY BY HAND. SAFETY GLASSES SHOULD ALSO BE WORN. IF THE BATTERY IS CRACKED OR LEAKING, THE ELECTROLYTE CAN BURN THE SKIN AND EYES.

(4) Remove the battery holddowns and remove the battery from the vehicle (Fig. 17).

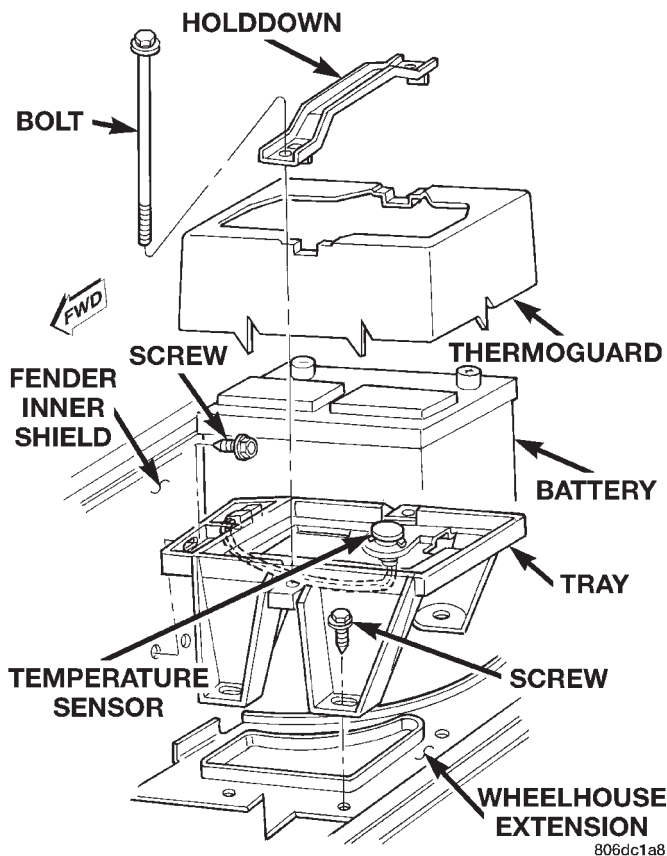


Fig. 17 Battery Holddowns

(5) Inspect the battery tray and holddowns for corrosion or damage. Remove any corrosion using a wire brush and a sodium bicarbonate (baking soda) and warm water cleaning solution. Paint any exposed bare metal and replace any damaged parts.

(6) Slide the thermoguard off of the battery case. Inspect the battery case for cracks or other damage that could result in electrolyte leaks. Also, check the battery terminal posts for looseness. Batteries with damaged cases or loose posts must be replaced.

(7) Check the electrolyte level in the battery. Use a putty knife or another suitable wide flat-bladed tool to pry the cell caps off (Fig. 18). Do not use a screwdriver. Add distilled water to each cell until the liquid reaches the bottom of the vent well. **DO NOT OVERFILL.**

(8) Inspect the battery built-in test indicator sight glass for an indication of the battery condition. If the

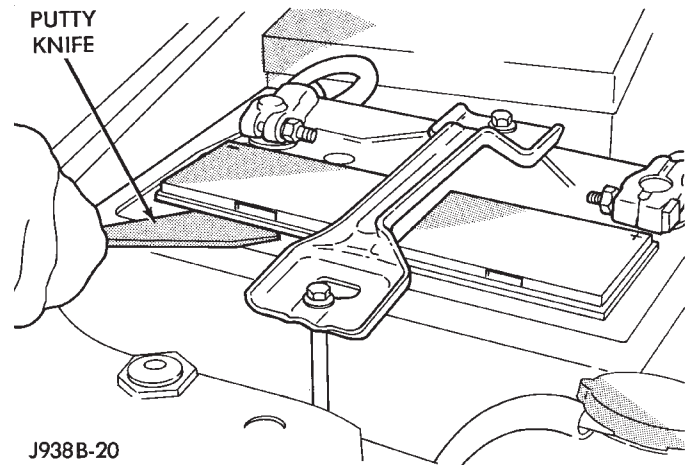
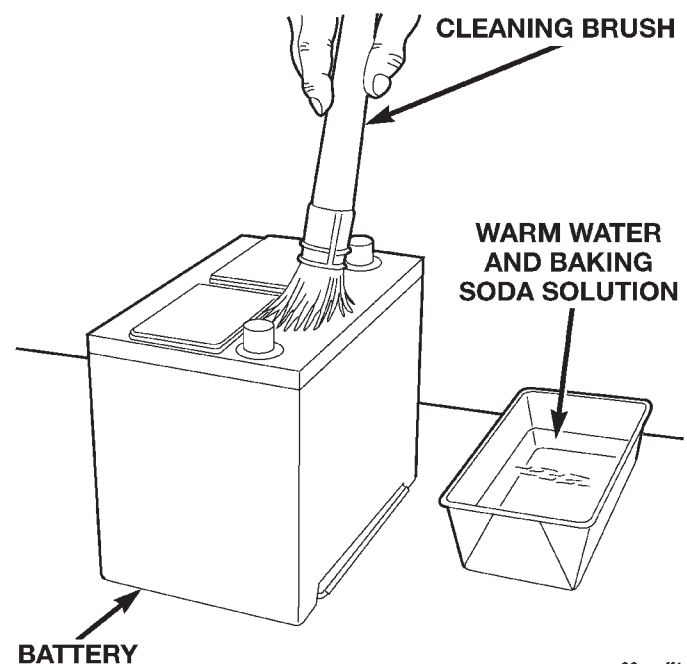


Fig. 18 Removing Cell Caps - Typical

battery is discharged, charge as required. See the Built-In Test Indicator and the Battery Charging procedures in this group for more information.

(9) If the battery is to be reinstalled, clean the outside of the battery case and the top cover with a sodium bicarbonate (baking soda) and warm water cleaning solution to remove any acid film (Fig. 19). Rinse the battery with clean water. Ensure that the cleaning solution does not enter the battery cells through the vent holes. If the battery is being replaced, see the Battery Ratings and Classifications chart in Specifications at the back of this group. Confirm that the replacement battery is the correct size and has the correct ratings for the vehicle.

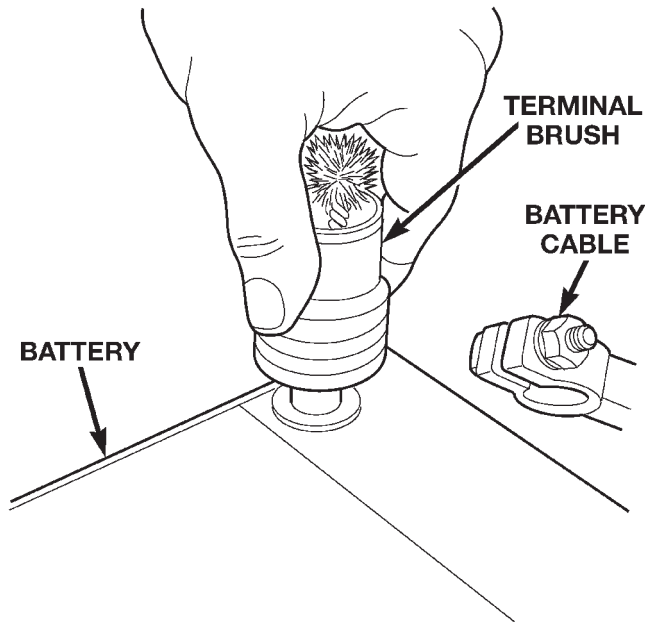


80accff1

Fig. 19 Clean Battery - Typical

REMOVAL AND INSTALLATION (Continued)

(10) Clean any corrosion from the battery terminal posts with a wire brush or a post and terminal cleaner, and a sodium bicarbonate (baking soda) and warm water cleaning solution (Fig. 20).

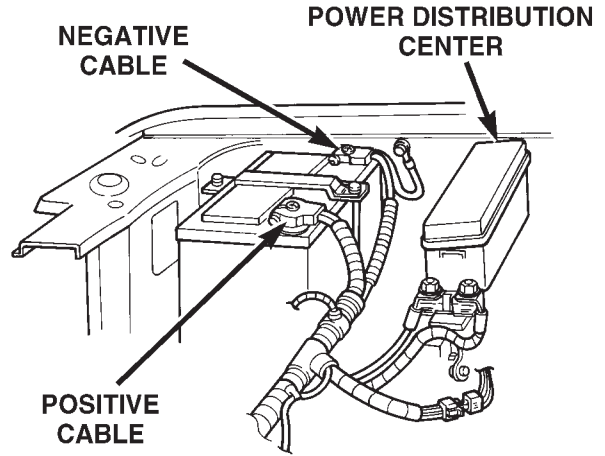


80accff2

Fig. 20 Clean Battery Terminal Post - Typical

(11) Position the battery in the tray. Ensure that the positive and negative terminal posts are correctly positioned. The cable terminal clamps must reach the correct battery post without stretching the cables (Fig. 21).

(12) Reinstall the battery thermoguard by sliding it over the battery case.



80a7233a

Fig. 21 Battery Cables

(13) Loosely install the battery holddown hardware. Ensure that the battery base is correctly positioned in the tray, then tighten the holddowns to 2.2 N·m (20 in. lbs.).

CAUTION: Be certain that the battery cables are connected to the correct battery terminals. Reverse polarity may damage electrical components.

(14) Install and tighten the battery positive cable terminal clamp. Then install and tighten the battery negative cable terminal clamp. Tighten both cable terminal clamp bolts to 8.5 N·m (75 in. lbs.).

(15) Apply a thin coating of petroleum jelly or chassis grease to the exposed surfaces of the cable terminal clamps and the battery terminal posts.

SPECIFICATIONS

BATTERY

Battery Classifications and Ratings					
Part Number	BCI Group Size Classification	Cold Cranking Amperage	Reserve Capacity	Ampere-Hours	Load Test Amperage
56044081	34	600	120 Minutes	66	300

STARTING SYSTEMS

CONTENTS

	page		page
GENERAL INFORMATION		CONTROL CIRCUIT TEST	5
INTRODUCTION	1	FEED CIRCUIT TEST	4
OVERVIEW	1	STARTING SYSTEM	2
DESCRIPTION AND OPERATION		REMOVAL AND INSTALLATION	
STARTER RELAY	2	STARTER RELAY	8
STARTER	2	STARTER	7
STARTING SYSTEM	1	SPECIFICATIONS	
DIAGNOSIS AND TESTING		STARTING SYSTEM	9
COLD CRANKING TEST	4		

GENERAL INFORMATION

OVERVIEW

The battery, starting, and charging systems operate with one another, and must be tested as a complete system. In order for the vehicle to start and charge properly, all of the components involved in these systems must perform within specifications.

Group 8A covers the battery, Group 8B covers the starting system, and Group 8C covers the charging system. Refer to Group 8W - Wiring Diagrams for complete circuit descriptions and diagrams. We have separated these systems to make it easier to locate the information you are seeking within this Service Manual. However, when attempting to diagnose any of these systems, it is important that you keep their interdependency in mind.

The diagnostic procedures used in these groups include the most basic conventional diagnostic methods, to the more sophisticated On-Board Diagnostics (OBD) built into the Powertrain Control Module (PCM). Use of a induction milliampere ammeter, volt/ohmmeter, battery charger, carbon pile rheostat (load tester), and 12-volt test lamp may be required.

All OBD-sensed systems are monitored by the PCM. Each monitored circuit is assigned a Diagnostic Trouble Code (DTC). The PCM will store a DTC in electronic memory for any failure it detects. See the On-Board Diagnostics Test in Group 8C - Charging System for more information.

INTRODUCTION

The starting system consists of:

- Battery
- Starter relay
- Starter with an integral solenoid
- Ignition switch

- Clutch pedal position switch (manual transmission)
- Park/neutral position switch (automatic transmission)

- Wire harness and connections.

This group covers diagnosis of the complete starting system, except the battery. However, this group only covers service procedures for the starter and starter relay. Service procedures for other starting system components can be located as follows:

- Battery - refer to Group 8A - Battery for the diagnostic and service procedures
- Ignition switch - refer to Group 8D - Ignition Systems for the service procedures
- Clutch pedal position switch - refer to Group 6 - Clutch for the service procedures
- Park/neutral position switch - refer to Group 21 - Transmission for the service procedures
- Wire harness and connections - refer to Group 8W - Wiring Diagrams for the service procedures.

DESCRIPTION AND OPERATION

STARTING SYSTEM

The starting system components form two separate circuits. A high-amperage feed circuit that feeds the starter between 150 and 350 amperes, and a low-amperage control circuit that operates on less than 20 amperes.

Battery voltage is supplied through the low-amperage control circuit to the coil battery terminal of the starter relay when the ignition switch is turned to the Start position. The park/neutral position switch is installed in series between the starter relay coil ground terminal and ground. This normally open switch prevents the starter relay from being energized unless the automatic transmission gear selector is in the Neutral or Park positions.

DESCRIPTION AND OPERATION (Continued)

When the starter relay coil is energized, the normally open relay contacts close. The relay contacts connect the relay common feed terminal to the relay normally open terminal. The closed relay contacts energize the starter solenoid coil windings.

The energized solenoid pull-in coil pulls in the solenoid plunger. The solenoid plunger pulls the shift lever in the starter. This engages the starter overrunning clutch and pinion gear with the starter ring gear on the automatic transmission torque converter (5.2L/5.9L engine), or the automatic transmission torque converter drive plate (4.0L engine).

As the solenoid plunger reaches the end of its travel, the solenoid contact disc completes the high-amperage starter feed circuit and energizes the solenoid plunger hold-in coil. Current now flows between the solenoid battery terminal and the starter motor, energizing the starter.

Once the engine starts, the overrunning clutch protects the starter from damage by allowing the starter pinion gear to spin faster than the pinion shaft. When the driver releases the ignition switch to the On position, the starter relay coil is de-energized. This causes the relay contacts to open. When the relay contacts open, the starter solenoid plunger hold-in coil is de-energized.

When the solenoid plunger hold-in coil is de-energized, the solenoid plunger return spring returns the plunger to its relaxed position. This causes the contact disc to open the starter feed circuit, and the shift lever to disengage the overrunning clutch and pinion gear from the starter ring gear.

STARTER

The starter motor incorporates several features to create a reliable, efficient, compact, and lightweight unit. A planetary gear system (intermediate transmission) is used between the electric motor and the pinion gear. This feature makes it possible to reduce the dimensions of the starter. At the same time, it allows higher armature rotational speed and delivers increased torque through the pinion gear to the starter ring gear on the automatic transmission torque converter or torque converter drive plate, or on the manual transmission flywheel.

The use of a permanent magnet field also reduces the size and weight of the starter. The permanent magnet field consists of four high-strength permanent magnets. The magnets are aligned according to their polarity, and are permanently mounted in the starter field frame.

The starter motors for all engines are activated by a solenoid mounted to the overrunning clutch housing. However, the starter motor and solenoid are serviced only as a complete assembly. If either

component is faulty or damaged, the entire starter assembly must be replaced.

CAUTION:

- Permanent magnet starters are highly sensitive to hammering, shocks, and external pressure. The permanent magnets may be damaged and the starter rendered unserviceable, if subjected to any of these conditions.

- The starter motor must not be clamped in a vise by the starter field frame. Doing so may damage the permanent magnets. The starter should only be clamped by the mounting flange.

- Do not connect the starter motor incorrectly when testing. Reverse polarity may damage the permanent magnets and render the starter unserviceable.

STARTER RELAY

The starter relay is a International Standards Organization (ISO) micro-relay. The terminal designations and functions are the same as a conventional ISO relay. However, the micro-relay terminal orientation (or footprint) is different, the current capacity is lower, and the relay case dimensions are smaller than those of the conventional ISO relay.

The starter relay is a electromechanical device that switches battery current to the pull-in coil of the starter solenoid when the ignition switch is turned to the Start position. See the Diagnosis and Testing section of this group for more information on the operation of the starter relay.

The starter relay is located in the Power Distribution Center (PDC), in the engine compartment. Refer to the PDC label for relay identification and location.

The starter relay cannot be repaired and, if faulty or damaged, it must be replaced.

DIAGNOSIS AND TESTING

STARTING SYSTEM

For circuit descriptions and diagrams, refer to 8W-21 - Starting System in Group 8W - Wiring Diagrams.

WARNING: ON VEHICLES EQUIPPED WITH AIR-BAGS, REFER TO GROUP 8M - PASSIVE RESTRAINT SYSTEMS BEFORE ATTEMPTING ANY STEERING WHEEL, STEERING COLUMN, OR INSTRUMENT PANEL COMPONENT DIAGNOSIS OR SERVICE. FAILURE TO TAKE THE PROPER PRECAUTIONS COULD RESULT IN ACCIDENTAL AIR-BAG DEPLOYMENT AND POSSIBLE PERSONAL INJURY.

DIAGNOSIS AND TESTING (Continued)

INSPECTION

Before removing any unit from the starting system for repair or diagnosis, perform the following inspections:

- **Battery** - Visually inspect the battery for indications of physical damage and loose or corroded cable connections. Determine the state-of-charge and cranking capacity of the battery. Charge or replace the battery, if required. Refer to Group 8A - Battery for more information.
- **Ignition Switch** - Visually inspect the ignition switch for indications of physical damage and loose or corroded wire harness connections.
- **Park/Neutral Position Switch** - Visually inspect the park/neutral position switch for indica-

tions of physical damage and loose or corroded wire harness connections.

- **Starter Relay** - Visually inspect the starter relay for indications of physical damage and loose or corroded wire harness connections.
- **Starter** - Visually inspect the starter for indications of physical damage and loose or corroded wire harness connections.
- **Starter Solenoid** - Visually inspect the starter solenoid for indications of physical damage and loose or corroded wire harness connections.
- **Wiring** - Visually inspect the wire harness for damage. Repair or replace any faulty wiring, as required.

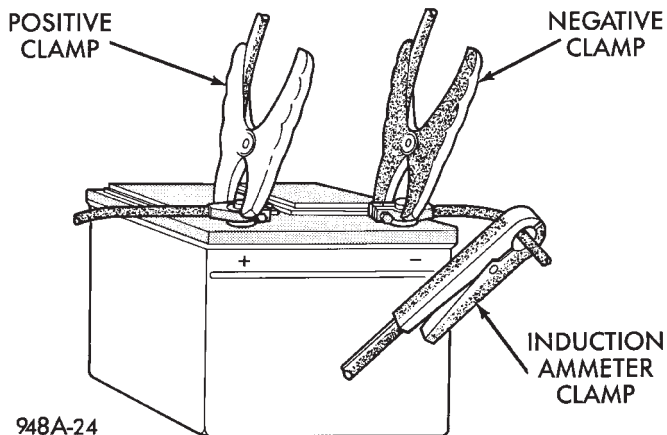
Starting System Diagnosis		
CONDITION	POSSIBLE CAUSE	CORRECTION
STARTER FAILS TO ENGAGE.	1. Battery discharged or faulty. 2. Starting circuit wiring faulty. 3. Starter relay faulty. 4. Ignition switch faulty. 5. Park/Neutral position switch (auto trans) faulty or misadjusted. 6. Starter solenoid faulty. 7. Starter assembly faulty.	1. Refer to Group 8A - Battery. Charge or replace battery, if required. 2. See Cold Cranking Test, in this group. Test and repair feed and/or control circuits, if required. 3. See Relay Test, in this group. Replace relay, if required. 4. See Ignition Switch Test, in this group. Replace switch, if required. 5. See Park/Neutral Position Switch Test, in this group. Replace switch, if required. 6. See Solenoid Test, in this Group. Replace starter assembly, if required. 7. If all other starting system components and circuits check OK, replace starter assembly.
STARTER ENGAGES, FAILS TO TURN ENGINE.	1. Battery discharged or faulty. 2. Starting circuit wiring faulty. 3. Starter assembly faulty. 4. Engine seized.	1. Refer to Group 8A - Battery. Charge or replace battery, if required. 2. See Cold Cranking Test, in this group. Test and repair feed and/or control circuits, if required. 3. If all other starting system components and circuits check OK, replace starter assembly. 4. Refer to Group 9 - Engine, for diagnostic and service procedures.
STARTER ENGAGES, SPINS OUT BEFORE ENGINE STARTS.	1. Broken teeth on starter ring gear. 2. Starter assembly faulty.	1. Remove starter as described in this group. Inspect ring gear and replace, if required. 2. If all other starting system components and circuits check OK, replace starter assembly.
STARTER DOES NOT DISENGAGE.	1. Starter improperly installed. 2. Starter relay faulty. 3. Ignition switch faulty. 4. Starter assembly faulty.	1. Install starter as described in this group. Tighten starter mounting hardware to correct torque specifications. 2. See Relay Test, in this group. Replace relay, if required. 3. See Ignition Switch Test, in this group. Replace switch, if required. 4. If all other starting system components and circuits check OK, replace starter assembly.

DIAGNOSIS AND TESTING (Continued)

COLD CRANKING TEST

For circuit descriptions and diagrams, refer to 8W-21 - Starting System in Group 8W - Wiring Diagrams. The battery must be fully-charged and load-tested before proceeding. Refer to Group 8A - Battery for more information.

(1) Connect a suitable volt-ampere tester to the battery terminals (Fig. 1). Refer to the operating instructions provided with the tester being used.



948A-24

Fig. 1 Volts-Amps Tester Connections - Typical

- (2) Fully engage the parking brake.
- (3) Place the automatic transmission gearshift selector lever in the Park position.
- (4) Verify that all lamps and accessories are turned off.
- (5) To prevent the engine from starting, unplug the Automatic ShutDown (ASD) relay. The ASD relay is located in the Power Distribution Center (PDC). Refer to the PDC label for relay identification and location.
- (6) Rotate and hold the ignition switch in the Start position. Note the cranking voltage and current (amperage) draw.

(a) If the voltage reads below 9.6 volts, remove the starter for bench testing. If the starter bench test is OK, refer to Group 9 - Engine for further diagnosis of the engine. If the starter bench test is not OK, replace the faulty starter.

(b) If the voltage reads above 9.6 volts and the current (amperage) draw reads below specifications, see the Feed Circuit Test procedures in this group.

(c) If the voltage reads 12.5 volts or greater and the starter does not turn, see the Control Circuit Test procedures in this group.

(d) If the voltage reads 12.5 volts or greater and the starter turns very slowly, see the Feed Circuit Test procedures in this group.

NOTE: A cold engine will increase the starter current (amperage) draw reading, and reduce the battery voltage reading.

FEED CIRCUIT TEST

The starter feed circuit test (voltage drop method) will determine if there is excessive resistance in the high-amperage circuit. For circuit descriptions and diagrams, refer to 8W-21 - Starting System in Group 8W - Wiring Diagrams.

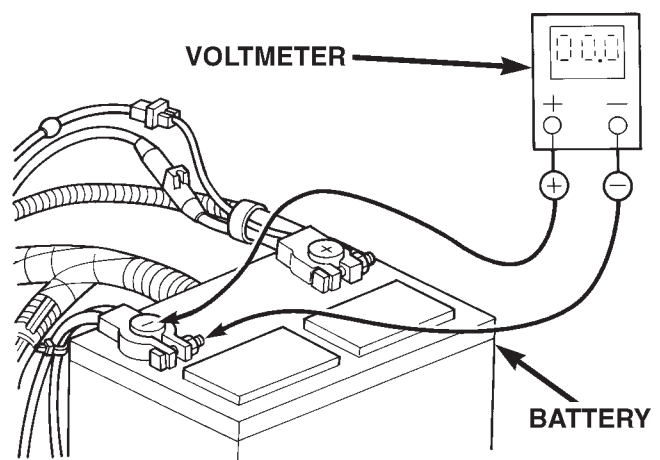
When performing these tests, it is important to remember that the voltage drop is giving an indication of the resistance between the two points at which the voltmeter probes are attached.

Example: When testing the resistance of the battery positive cable, touch the voltmeter leads to the battery positive cable clamp and the cable connector at the starter solenoid. If you probe the battery positive terminal post and the cable connector at the starter solenoid, you are reading the combined voltage drop in the battery positive cable clamp-to-terminal post connection and the battery positive cable.

The following operation will require a voltmeter accurate to 1/10 (0.10) volt. Before performing the tests, be certain that the following procedures are accomplished:

- Battery is fully-charged. Refer to Group 8A - Battery for more information.
- Fully engage the parking brake.
- Place the automatic transmission gearshift selector lever in the Park position.
- Unplug the Automatic ShutDown (ASD) relay to prevent the engine from starting. The ASD relay is located in the Power Distribution Center (PDC). Refer to the PDC label for ASD relay identification and location.

(1) Connect the positive lead of the voltmeter to the battery negative terminal post. Connect the negative lead of the voltmeter to the battery negative cable clamp (Fig. 2). Rotate and hold the ignition switch in the Start position. Observe the voltmeter. If voltage is detected, correct the poor contact between the cable clamp and the terminal post.



80660062

Fig. 2 Test Battery Negative Connection Resistance - Typical

DIAGNOSIS AND TESTING (Continued)

(2) Connect the positive lead of the voltmeter to the battery positive terminal post. Connect the negative lead of the voltmeter to the battery positive cable clamp (Fig. 3). Rotate and hold the ignition switch in the Start position. Observe the voltmeter. If voltage is detected, correct the poor contact between the cable clamp and the terminal post.

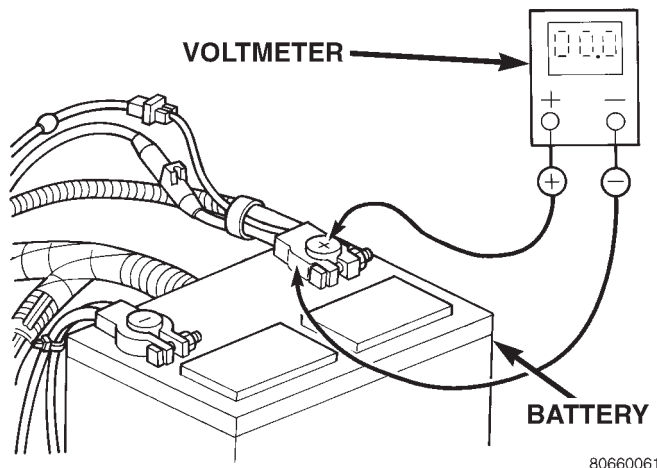


Fig. 3 Test Battery Positive Connection Resistance - Typical

(3) Connect the voltmeter to measure between the battery positive terminal post and the starter solenoid battery terminal stud (Fig. 4). Rotate and hold the ignition switch in the Start position. Observe the voltmeter. If the reading is above 0.2 volt, clean and tighten the battery cable connection at the solenoid. Repeat the test. If the reading is still above 0.2 volt, replace the faulty battery positive cable.

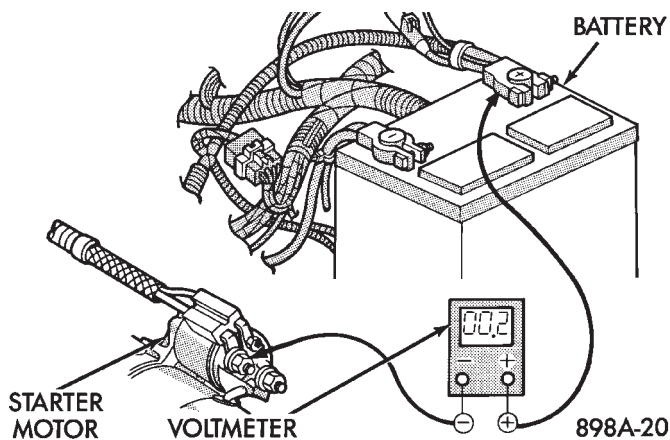


Fig. 4 Test Battery Positive Cable Resistance - Typical

(4) Connect the voltmeter to measure between the battery negative terminal post and a good clean ground on the engine block (Fig. 5). Rotate and hold the ignition switch in the Start position. Observe the voltmeter. If the reading is above 0.2 volt, clean and

tighten the battery negative cable attachment on the engine block. Repeat the test. If the reading is still above 0.2 volt, replace the faulty battery negative cable.

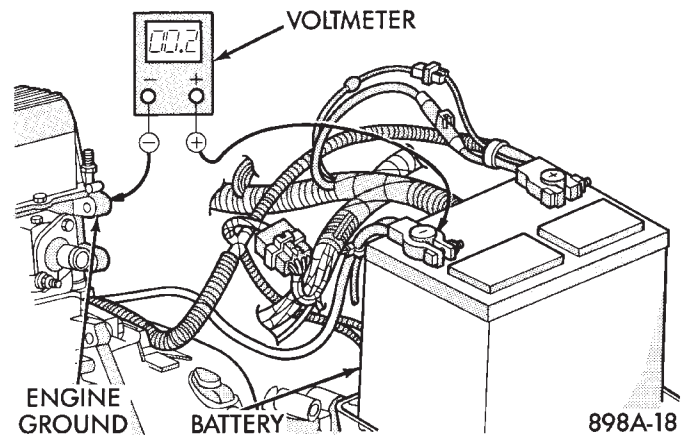


Fig. 5 Test Ground Circuit Resistance - Typical

(5) Connect the positive lead of the voltmeter to the starter housing. Connect the negative lead of the voltmeter to the battery negative terminal post (Fig. 6). Rotate and hold the ignition switch in the Start position. Observe the voltmeter. If the reading is above 0.2 volt, correct the poor starter to engine block ground contact.

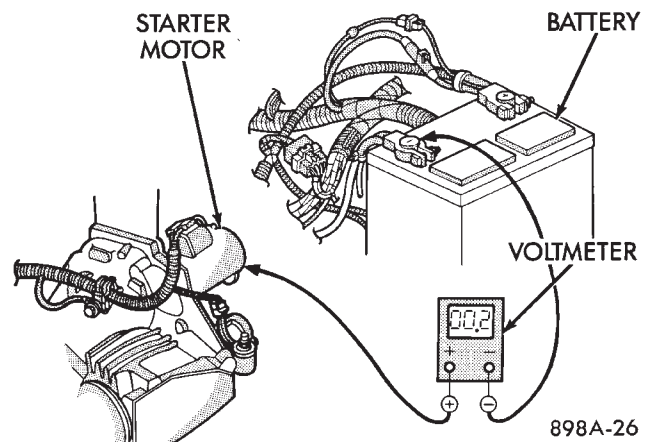


Fig. 6 Test Starter Ground - Typical

If the resistance tests detect no feed circuit problems, remove the starter and see the Solenoid Test procedure in this group.

CONTROL CIRCUIT TEST

For circuit descriptions and diagrams, refer to 8W-21 - Starting System in Group 8W - Wiring Diagrams. The starter control circuit consists of:

- Battery
- Starter relay
- Starter solenoid
- Ignition switch

DIAGNOSIS AND TESTING (Continued)

- Park/neutral position switch
- Wire harness and connections.

Test procedures for these components should be performed in the order in which they are listed, as follows:

SOLENOID TEST

Remove the starter as described in this group. Then proceed as follows:

- (1) Remove the wire from the solenoid field coil terminal.
- (2) Check for continuity between the solenoid terminal and field coil terminal with a continuity tester (Fig. 7). There should be continuity. If OK, go to Step 3. If not OK, replace the faulty starter assembly.

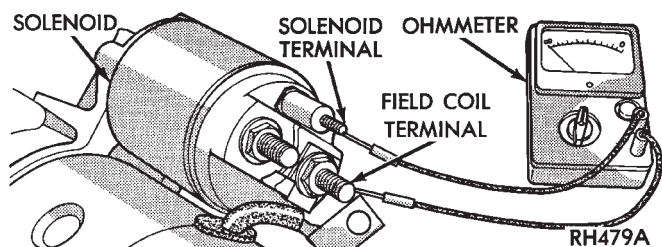


Fig. 7 Continuity Test Between Solenoid Terminal and Field Coil Terminal

- (3) Check for continuity between the solenoid terminal and the solenoid case (Fig. 8). There should be continuity. If OK, go to Step 4. If not OK, replace the faulty starter assembly.

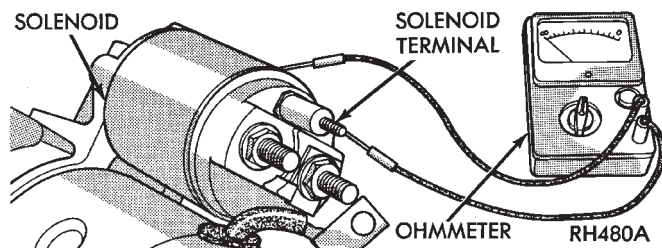


Fig. 8 Continuity Test Between Solenoid Terminal and Solenoid Case

- (4) Connect the solenoid field coil wire to the field coil terminal.
- (5) Install the starter as described in this group.

RELAY TEST

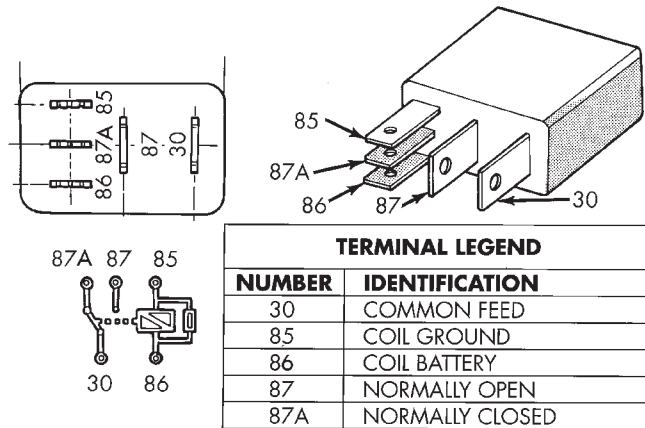
The starter relay (Fig. 9) is located in the Power Distribution Center (PDC) in the engine compartment. Refer to the PDC label for relay identification and location.

Remove the starter relay from the PDC as described in this group to perform the following tests:

- (1) A relay in the de-energized position should have continuity between terminals 87A and 30, and no continuity between terminals 87 and 30. If OK, go to Step 2. If not OK, replace the faulty relay.

- (2) Resistance between terminals 85 and 86 (electromagnet) should be 75 ± 5 ohms. If OK, go to Step 3. If not OK, replace the faulty relay.

- (3) Connect a battery to terminals 85 and 86. There should now be continuity between terminals 30 and 87, and no continuity between terminals 87A and 30. If OK, see the Relay Circuit Test procedure in this group. If not OK, replace the faulty relay.



9514-16

Fig. 9 Starter Relay

RELAY CIRCUIT TEST

- (1) The relay common feed terminal cavity (30) is connected to battery voltage and should be hot at all times. If OK, go to Step 2. If not OK, repair the open circuit to the PDC fuse as required.

- (2) The relay normally closed terminal (87A) is connected to terminal 30 in the de-energized position, but is not used for this application. Go to Step 3.

- (3) The relay normally open terminal (87) is connected to the common feed terminal (30) in the energized position. This terminal supplies battery voltage to the starter solenoid field coils. There should be continuity between the cavity for relay terminal 87 and the starter solenoid terminal at all times. If OK, go to Step 4. If not OK, repair the open circuit to the starter solenoid as required.

- (4) The coil battery terminal (86) is connected to the electromagnet in the relay. It is energized when the ignition switch is held in the Start position. Check for battery voltage at the cavity for relay terminal 86 with the ignition switch in the Start position, and no voltage when the ignition switch is released to the On position. If OK, go to Step 5. If not OK, check for an open or short circuit to the ignition switch and repair, if required. If the circuit to the ignition switch is OK, see the Ignition Switch Test procedure in this group.

- (5) The coil ground terminal (85) is connected to the electromagnet in the relay. It is grounded through the park/neutral position switch only when the gearshift selector lever is in the Park or Neutral

DIAGNOSIS AND TESTING (Continued)

positions. Check for continuity to ground at the cavity for relay terminal 85. If not OK, check for an open or short circuit to the park/neutral position switch and repair, if required. If the circuit is OK, see the Park/Neutral Position Switch Test procedure in this group.

PARK/NEUTRAL POSITION SWITCH TEST

(1) Place the transmission gear selector lever in the Park position.

(2) Disconnect and isolate the battery negative cable.

(3) Raise and support the vehicle.

(4) Unplug the park/neutral position switch wire harness connector.

(5) Check for continuity between the center switch terminal and a good chassis ground. There should be continuity. If OK, go to Step 6. If not OK, replace the faulty switch.

(6) Move the transmission gear selector to the Reverse position and check for continuity between the center switch terminal and a good chassis ground. There should be no continuity. If not OK, replace the faulty switch.

IGNITION SWITCH TEST

WARNING: ON VEHICLES EQUIPPED WITH AIR-BAGS, REFER TO GROUP 8M - PASSIVE RESTRAINT SYSTEMS BEFORE ATTEMPTING ANY STEERING WHEEL, STEERING COLUMN, OR INSTRUMENT PANEL COMPONENT DIAGNOSIS OR SERVICE. FAILURE TO TAKE THE PROPER PRECAUTIONS COULD RESULT IN ACCIDENTAL AIR-BAG DEPLOYMENT AND POSSIBLE PERSONAL INJURY.

(1) Disconnect and isolate the battery negative cable.

(2) Remove the steering column shrouds and unplug the ignition switch wire harness connector. Refer to Group 8D - Ignition Systems for the procedures.

(3) With the ignition switch in the On position, check for continuity between the ignition switch terminals 1 and 7. These are the terminals at each end of the switch connector. There should be no continuity. If OK, go to Step 4. If not OK, replace the faulty switch.

(4) With the ignition switch held in the Start position, check for continuity between the ignition switch terminals 1 and 7 again. There should now be continuity. If not OK, replace the faulty switch.

REMOVAL AND INSTALLATION

STARTER

4.0L ENGINE

(1) Disconnect and isolate the battery negative cable.

(2) Raise and support the vehicle.

(3) Disconnect the battery cable and solenoid feed wire from the starter solenoid (Fig. 10).

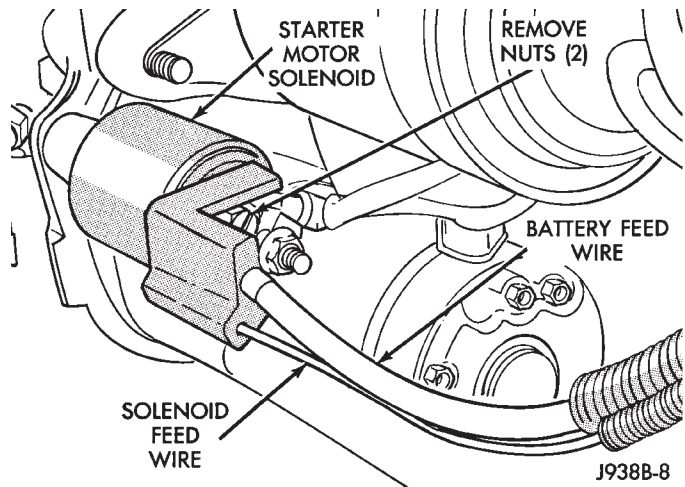


Fig. 10 Starter Wire Harness Remove/Install - Typical

(4) Remove the front starter mounting bolt and the automatic transmission oil cooler line bracket (Fig. 11).

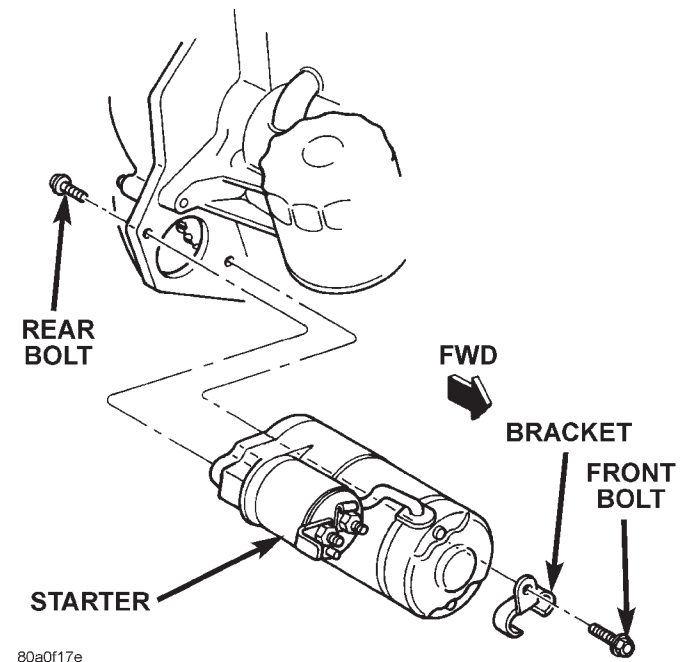


Fig. 11 Starter Remove/Install - 4.0L Engine

REMOVAL AND INSTALLATION (Continued)

(5) Remove the rear starter mounting bolt and lower the starter.

(6) Reverse the removal procedures to install. Tighten the starter hardware as follows:

- Upper mounting bolt - 55 N·m (40 ft. lbs.)
- Lower mounting bolt - 41 N·m (30 ft. lbs.)
- Solenoid battery cable nut - 10 N·m (90 in. lbs.)
- Solenoid terminal nut - 6 N·m (55 in. lbs.)

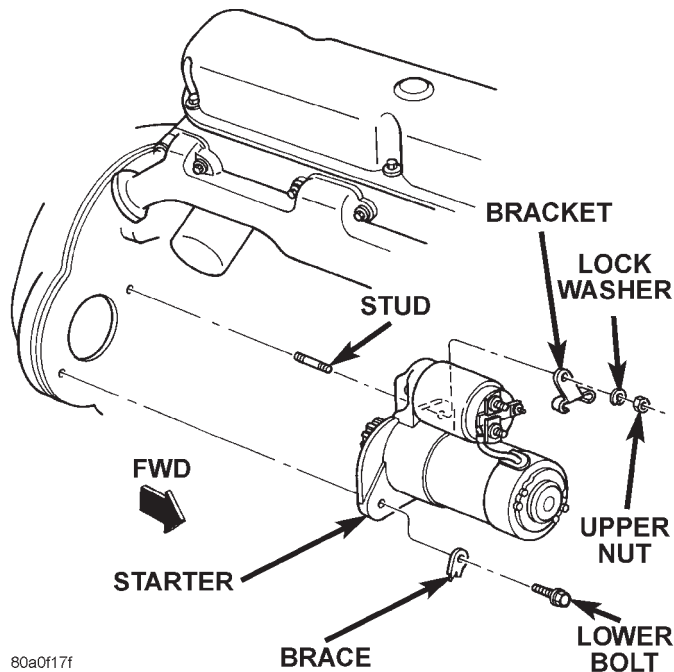
5.2L AND 5.9L ENGINE

(1) Disconnect and isolate the battery negative cable.

(2) Raise and support the vehicle.

(3) Disconnect the battery cable and solenoid feed wire from the starter solenoid (Fig. 10).

(4) Remove the lower starter mounting bolt and the exhaust brace (Fig. 12).



80a0f17f

Fig. 12 Starter Remove/Install - 5.2L and 5.9L Engine

(5) Remove the upper starter mounting nut, lock washer, and automatic transmission oil cooler line bracket.

(6) Move the starter towards the front of the vehicle until the starter gear housing nose clears the bell-housing. Then tilt the starter nose downwards past the exhaust pipe.

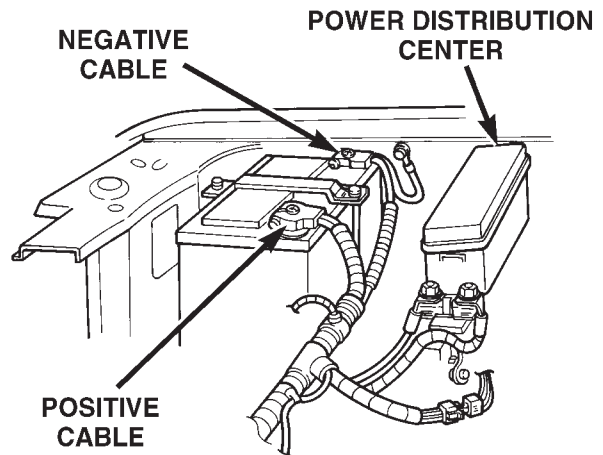
(7) Reverse the removal procedures to install. Tighten the starter hardware as follows:

- Lower mounting bolt - 68 N·m (50 ft. lbs.)
- Upper mounting nut - 68 N·m (50 ft. lbs.)
- Solenoid battery cable nut - 10 N·m (90 in. lbs.)
- Solenoid terminal nut - 6 N·m (55 in. lbs.)

STARTER RELAY

(1) Disconnect and isolate the battery negative cable.

(2) Remove the cover from the Power Distribution Center (PDC) (Fig. 13).



80a7233a

Fig. 13 Power Distribution Center

(3) Refer to the label on the PDC for starter relay identification and location.

(4) Unplug the starter relay from the PDC.

(5) Install the starter relay by aligning the relay terminals with the cavities in the PDC and pushing the relay firmly into place.

(6) Install the PDC cover.

(7) Connect the battery negative cable.

(8) Test the relay operation.

SPECIFICATIONS

STARTING SYSTEM

Starter and Solenoid		
Manufacturer	Mitsubishi	Mitsubishi
Engine Application	4.0L	5.2L/5.9L
Power Rating	1.4 Kilowatt	1.4 Kilowatt
Voltage	12 Volts	12 Volts
Number of Fields	4	4
Number of Poles	4	4
Number of Brushes	4	4
Drive Type	Planetary Gear Reduction	Planetary Gear Reduction
Free Running Test Voltage	11.2 Volts	11.2 Volts
Free Running Test Maximum Amperage Draw	80 Amperes	80 Amperes
Free Running Test Minimum Speed	2500 rpm	2500 rpm
Solenoid Closing Maximum Voltage	7.8 Volts	7.8 Volts
*Cranking Amperage Draw Test	160 Amperes	160 Amperes
*Test at operating temperature. Cold engine, tight (new) engine, or heavy oil will increase starter amperage draw.		

STARTING SYSTEMS

CONTENTS

	page		page
REMOVAL AND INSTALLATION		SPECIFICATIONS	
STARTER	1	STARTING SYSTEM	2
STARTER RELAY	1		

REMOVAL AND INSTALLATION

STARTER

2.5L DIESEL ENGINE

- (1) Disconnect and isolate the battery negative cable.
- (2) Raise and support the vehicle.
- (3) Remove the right front engine mount insulator and brackets. Refer to Group 9 - Engines for the procedures.
- (4) Remove the starter front support bracket (Fig. 1).

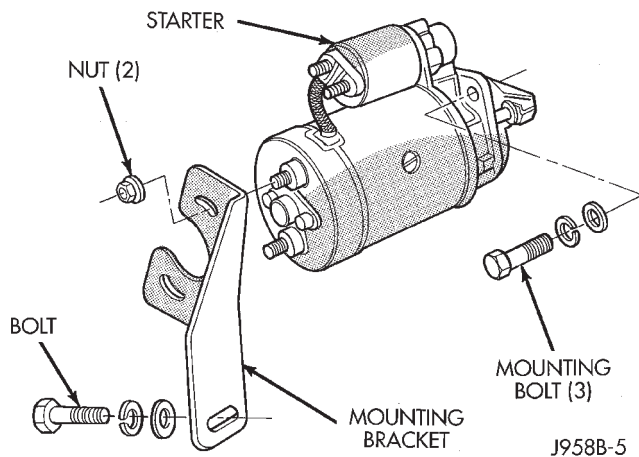


Fig. 1 Starter Mounting - 2.5L Diesel Engine

- (5) Remove the strap that secures the starter heat shield and remove the heat shield from the starter (Fig. 2).
- (6) Remove the three bolts that secure the starter mounting flange to the transmission adapter plate.
- (7) Lower the starter far enough to access and remove the wire harness connections from the solenoid.
- (8) Remove the starter from the vehicle.
- (9) Reverse the removal procedures to install. Tighten the starter hardware as follows:
 - Battery cable terminal nut - 27 N·m (20 ft. lbs.)
 - Starter mounting bolts - 27 N·m (20 ft. lbs.)

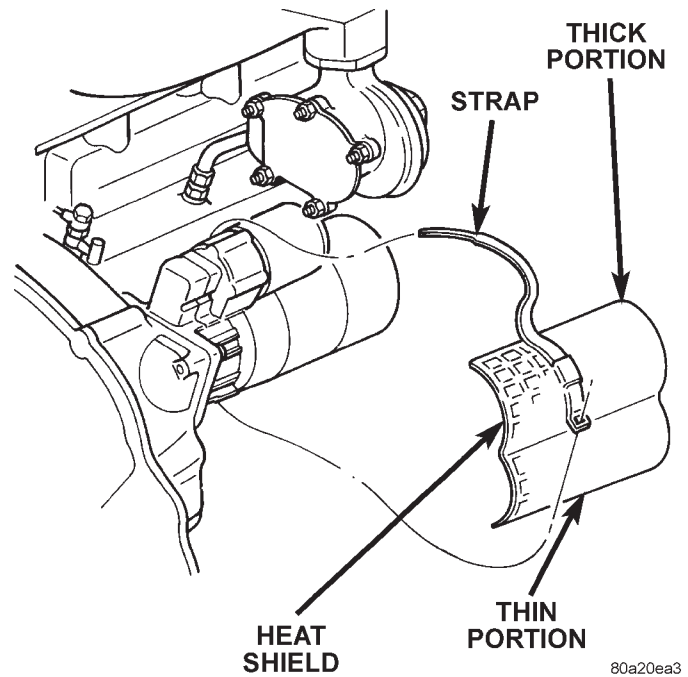


Fig. 2 Starter Heat Shield Remove/Install

- Front starter support bracket nuts - 10 N·m (90 in. lbs.)
- Front starter support bracket bolt - 47 N·m (35 ft. lbs.)

STARTER RELAY

- (1) Disconnect and isolate the battery negative cable.
- (2) Remove the cover from the Power Distribution Center (PDC).
- (3) Refer to the label on the PDC for starter relay identification and location.
- (4) Unplug the starter relay from the PDC.
- (5) Install the starter relay by aligning the relay terminals with the cavities in the PDC and pushing the relay firmly into place.
- (6) Install the PDC cover.
- (7) Connect the battery negative cable.
- (8) Test the relay operation.

SPECIFICATIONS**STARTING SYSTEM**

Starter and Solenoid	
Engine Application	2.5L Diesel
Power Rating	2.2 Kilowatt
Voltage	12 Volts
Number of Fields	4
Number of Poles	4
Number of Brushes	4
Drive Type	Planetary Gear Reduction
Free Running Test Voltage	11.5 Volts
Free Running Test Maximum Amperage Draw	160 Amperes
Free Running Test Minimum Speed	5500 rpm
Solenoid Closing Maximum Voltage	7.8 Volts
*Cranking Amperage Draw test	350 Amperes
*Test at operating temperature. Cold engine, tight (new) engine, or heavy oil will increase starter amperage draw.	

CHARGING SYSTEM

CONTENTS

	page		page
GENERAL INFORMATION		CHARGING SYSTEM	2
OVERVIEW	1	CURRENT OUTPUT TEST	4
DESCRIPTION AND OPERATION		ON-BOARD DIAGNOSTIC TEST FOR	
BATTERY TEMPERATURE SENSOR	2	CHARGING SYSTEM	6
CHARGING SYSTEM OPERATION	1	REMOVAL AND INSTALLATION	
ELECTRONIC VOLTAGE REGULATOR	2	BATTERY TEMPERATURE SENSOR	7
GENERATOR	2	GENERATOR	6
DIAGNOSIS AND TESTING		SPECIFICATIONS	
BATTERY TEMPERATURE SENSOR	5	GENERATOR RATINGS	8
CHARGING SYSTEM RESISTANCE TESTS ...	3	TORQUE CHART	8

GENERAL INFORMATION

OVERVIEW

The battery, starting, and charging systems operate with one another, and must be tested as a complete system. To allow the vehicle to start and charge properly, all of the components involved in these three systems must perform within specifications.

Group 8A in this service manual covers the battery, Group 8B covers the starting system, and Group 8C covers the charging system. Refer to Group 8W, Wiring Diagrams for complete circuit descriptions and diagrams. When attempting to diagnose any of these systems, it is important to keep their interdependency in mind.

Certain charging system circuits are monitored by On-Board Diagnostics (OBD) built into the Powertrain Control Module (PCM). Each monitored circuit is assigned a Diagnostic Trouble Code (DTC). The PCM will store a DTC in electronic memory for certain failures it detects. Refer to On-Board Diagnostics in Group 25, Emission Control System for a complete list of DTC's and for information necessary to access a DTC. For charging system diagnostic information, refer to the appropriate Powertrain Diagnostic Procedures service manual.

DESCRIPTION AND OPERATION

CHARGING SYSTEM OPERATION

The charging system consists of:

- Generator
- Electronic Voltage Regulator (EVR) circuitry

within the Powertrain Control Module (PCM)

- Ignition switch (refer to Group 8D, Ignition System for information)
- Battery (refer to Group 8A, Battery for information)
- Battery temperature sensor
- Generator Lamp (if equipped)
- Check Gauges Lamp (if equipped)
- Voltmeter (refer to Group 8E, Instrument Panel and Gauges for information)
- Wiring harness and connections (refer to Group 8W, Wiring for information)

The charging system is turned on and off with the ignition switch. When the ignition switch is turned to the ON position, battery voltage from the powertrain control module (PCM) is supplied to the generator rotor to produce a magnetic field. This is done through one of the two field terminals at the rear of generator.

The amount of DC current produced by the generator is controlled by the EVR (field control) circuitry contained within the PCM. This circuitry is connected in series with the second rotor field terminal and ground.

A battery temperature sensor, located in the battery tray housing, is used to sense battery temperature. This temperature data, along with data from monitored line voltage, is used by the PCM to vary the battery charging rate. This is done by cycling the ground path to control the strength of the rotor magnetic field. The PCM then compensates and regulates generator current output accordingly.

All vehicles are equipped with On-Board Diagnostics (OBD). All OBD-sensed systems, including EVR (field control) circuitry, are monitored by the PCM. Each monitored circuit is assigned a Diagnostic Trouble Code (DTC). The PCM will store a DTC in elec-

DESCRIPTION AND OPERATION (Continued)

tronic memory for certain failures it detects. Refer to On-Board Diagnostics in Group 25, Emission Control System for more DTC information.

The Check Gauges Lamp (if equipped) monitors: **charging system voltage**, engine coolant temperature and engine oil pressure. If an extreme condition is indicated, the lamp will be illuminated. This is done as reminder to check the three gauges. The signal to activate the lamp is sent via the CCD bus circuits. The lamp is located on the instrument panel. Refer to Group 8E, Instrument Panel and Gauges for additional information.

GENERATOR

The generator is belt-driven by the engine using a serpentine type drive belt. It is serviced only as a complete assembly. If the generator fails for any reason, the entire assembly must be replaced.

As the energized rotor begins to rotate within the generator, the spinning magnetic field induces a current into the windings of the stator coil. Once the generator begins producing sufficient current, it also provides the current needed to energize the rotor.

The Y type stator winding connections deliver the induced AC current to 3 positive and 3 negative diodes for rectification. From the diodes, rectified DC current is delivered to the vehicle electrical system through the generator battery and ground terminals.

Although the generators appear the same externally, different generators with different output ratings are used on this vehicle. Be certain that the replacement generator has the same output rating and part number as the original unit. Refer to Generator Ratings in the Specifications section at the back of this group for amperage ratings and part numbers.

Noise emitting from the generator may be caused by: worn, loose or defective bearings; a loose or defective drive pulley; incorrect, worn, damaged or misadjusted fan drive belt; loose mounting bolts; a misaligned drive pulley or a defective stator or diode.

BATTERY TEMPERATURE SENSOR

The battery temperature sensor is used to determine the battery temperature and control battery charging rate. This temperature data, along with data from monitored line voltage, is used by the PCM to vary the battery charging rate. System voltage will be higher at colder temperatures and is gradually reduced at warmer temperatures.

ELECTRONIC VOLTAGE REGULATOR

The Electronic Voltage Regulator (EVR) is not a separate component. It is actually a voltage regulating circuit located within the Powertrain Control

Module (PCM). The EVR is not serviced separately. If replacement is necessary, the PCM must be replaced.

Operation: The amount of DC current produced by the generator is controlled by EVR circuitry contained within the PCM. This circuitry is connected in series with the generator's second rotor field terminal and its ground.

Voltage is regulated by cycling the ground path to control the strength of the rotor magnetic field. The EVR circuitry monitors system line voltage and battery temperature (refer to Battery Temperature Sensor for more information). It then compensates and regulates generator current output accordingly. Also refer to Charging System Operation for additional information.

DIAGNOSIS AND TESTING

CHARGING SYSTEM

The following procedures may be used to diagnose the charging system if:

- the generator lamp (if equipped) is illuminated with the engine running
- the voltmeter (if equipped) does not register properly
- an undercharged or overcharged battery condition occurs.

Remember that an undercharged battery is often caused by:

- accessories being left on with the engine not running
- a faulty or improperly adjusted switch that allows a lamp to stay on. See Ignition-Off Draw Test in Group 8A, Battery for more information.

INSPECTION

To perform a complete test of the charging system, refer to the appropriate Powertrain Diagnostic Procedures service manual and the DRB scan tool. Perform the following inspections before attaching the scan tool.

- (1) Inspect the battery condition. Refer to Group 8A, Battery for procedures.
- (2) Inspect condition of battery cable terminals, battery posts, connections at engine block, starter solenoid and relay. They should be clean and tight. Repair as required.
- (3) Inspect all fuses in both the fuseblock and Power Distribution Center (PDC) for tightness in receptacles. They should be properly installed and tight. Repair or replace as required.
- (4) Inspect generator mounting bolts for tightness. Replace or tighten bolts if required. Refer to the Generator Removal/Installation section of this group for torque specifications.

DIAGNOSIS AND TESTING (Continued)

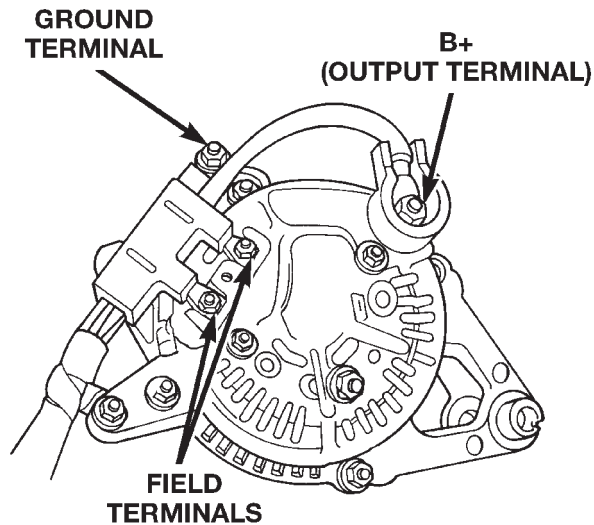
(5) Inspect generator drive belt condition and tension. Tighten or replace belt as required. Refer to Belt Tension Specifications in Group 7, Cooling System.

(6) Inspect automatic belt tensioner (if equipped). Refer to Group 7, Cooling System for information.

(7) Inspect connections at generator field, battery output, and ground terminals. Also check ground connection at engine. They should all be clean and tight. Repair as required.

CHARGING SYSTEM RESISTANCE TESTS

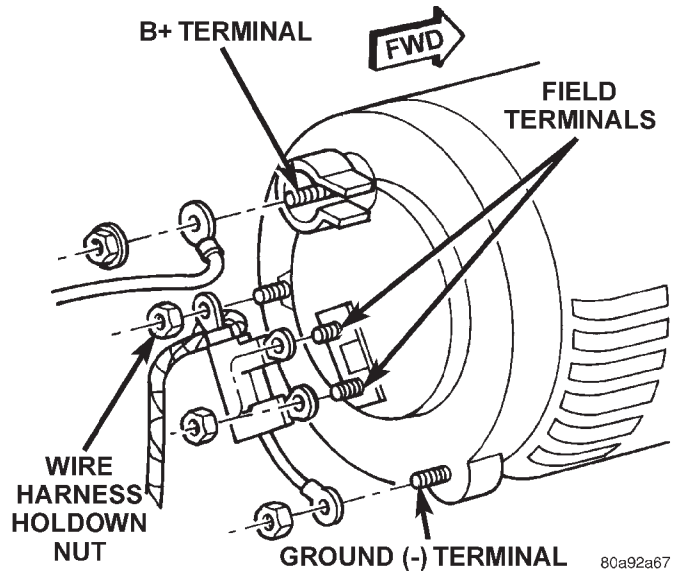
These tests will show the amount of voltage drop across the generator output wire, from the generator output (B+) terminal to the battery positive post. They will also show the amount of voltage drop from the ground (-) terminal on the generator to the battery negative post. Typical generator wiring harnesses are shown in (Fig. 1) or (Fig. 2). Wiring harness routing as shown may be slightly different depending on vehicle model and/or engine. Refer to Group 8W, Wiring Diagrams for additional information.



80a3cc69

Fig. 1 Generator Terminals (Typical Wiring Harness Shown)

A voltmeter with a 0–18 volt DC scale should be used for these tests. By repositioning the voltmeter test leads, the point of high resistance (voltage drop) can easily be found.



80a92a67

Fig. 2 Generator Terminals (Typical Wiring Harness Shown)

PREPARATION

- (1) Before starting test, make sure battery is in good condition and is fully-charged. See Group 8A, Battery for more information.
- (2) Check condition of battery cables at battery. Clean if necessary.
- (3) Start the engine and allow it to reach normal operating temperature.
- (4) Shut engine off.
- (5) Connect an engine tachometer.
- (6) Fully engage the parking brake.

TEST

- (1) Start engine.
- (2) Place heater blower in high position.
- (3) Turn on headlamps and place in high-beam position.
- (4) Turn vehicle interior lamps on.
- (5) Bring engine speed up to 2400 rpm and hold.
- (6) Testing (+) circuitry:
 - (a) Touch the negative lead of voltmeter directly to battery positive post.
 - (b) Touch the positive lead of voltmeter to the B+ output terminal stud on the generator (not the terminal mounting nut). Voltage should be no higher than 0.6 volts. If voltage is higher than 0.6 volts, touch test lead to terminal mounting stud nut and then to the wiring connector. If voltage is now below 0.6 volts, look for dirty, loose or poor connection at this point. Also check condition of the generator output wire-to-battery bullet connector (if equipped).

DIAGNOSIS AND TESTING (Continued)

Refer to Group 8, Wiring for connector location. A voltage drop test may be performed at each (+) connection in this circuit to locate the excessive resistance.

(7) Testing (-) circuitry:

(a) Touch the negative lead of voltmeter directly to battery negative post.

(b) Touch the positive lead of voltmeter to the ground terminal stud on the generator case (not the terminal mounting nut). Voltage should be no higher than 0.3 volts. If voltage is higher than 0.3 volts, touch test lead to terminal mounting stud nut and then to the wiring connector. If voltage is now below 0.3 volts, look for dirty, loose or poor connection at this point. A voltage drop test may be performed at each (-) connection in this circuit to locate the excessive resistance. This test can also be performed between the generator case and the engine. If test voltage is higher than 0.3 volts, check for corrosion at generator mounting points or loose generator mounting.

CURRENT OUTPUT TEST

The current output test will determine if the charging system can deliver its minimum test current (amperage) output. Refer to the Specifications section at the end of this group for minimum test current (amperage) requirements.

The first part of this test (Test 1) will determine the combined amperage output of both the generator and the Electronic Voltage Regulator (EVR) circuitry. The second part of this test (Test 2) will determine only generator amperage and **will not** include analysis of EVR circuitry. EVR circuitry is located within the Powertrain Control Module (PCM). To test voltage regulator circuitry, refer to the appropriate Powertrain Diagnostic Procedures service manual.

PREPARATION

(1) Determine if any Diagnostic Trouble Codes (DTC's) exist. To determine a DTC, refer to On-Board Diagnostics in this group. For repair, refer to the appropriate Powertrain Diagnostic Procedures manual.

(2) Before starting test, make sure battery is in good condition and is fully-charged. See Group 8A, Battery for more information.

(3) Check condition of battery cables at battery. Clean if necessary.

(4) Perform the previous Charging System Resistance Tests (voltage drop tests). This will ensure clean and tight generator/battery electrical connections.

(5) Be sure the generator drive belt is properly tensioned. Refer to Group 7, Cooling System for information.

(6) A volt/amp tester equipped with both a battery load control (carbon pile rheostat) and an inductive-type pickup clamp (ammeter probe) will be used for this test. Refer to operating instructions supplied with tester. When using a tester equipped with an inductive-type clamp, removal of wiring at the generator will not be necessary.

(7) Start the engine and allow it to reach operating temperature.

(8) Shut engine off.

(9) Turn off all electrical accessories and all vehicle lighting.

(10) Connect the volt/amp tester leads to the battery. Be sure the carbon pile rheostat control is in the OPEN or OFF position before connecting leads. See Load Test in Group 8A, Battery for more information. Also refer to the operating instructions supplied with test equipment.

(11) Connect the inductive clamp (ammeter probe). Refer to the operating instructions supplied with test equipment.

(12) If volt/amp tester is not equipped with an engine tachometer, connect a separate tachometer to the engine.

TEST 1

(1) Perform the previous test Preparation.

(2) Fully engage the parking brake.

(3) Start engine.

(4) Bring engine speed to 2500 rpm.

(5) With engine speed held at 2500 rpm, slowly adjust the rheostat control (load) on the tester to obtain the highest amperage reading. Do not allow voltage to drop below 12 volts. Record the reading. **This load test must be performed within 15 seconds to prevent damage to test equipment.** On certain brands of test equipment, this load will be applied automatically. Refer to the operating manual supplied with test equipment.

(6) The ammeter reading must meet the Minimum Test Amps specifications as displayed in the Generator Ratings chart. This can be found in the Specifications section at the end of this group. A label stating a part reference number is attached to the generator case. On some engines this label may be located on the bottom of the case. Compare this reference number to the Generator Ratings chart.

(7) Rotate the load control to the OFF position.

(8) Continue holding engine speed at 2500. If EVR circuitry is OK, amperage should drop below 15–20 amps. With all electrical accessories and vehicle lighting off, this could take several minutes of engine operation. If amperage did not drop, refer to the appropriate Powertrain Diagnostic Procedures manual for testing.

(9) Remove volt/amp tester.

DIAGNOSIS AND TESTING (Continued)

If minimum amperage could not be met, proceed to Test 2. This test will determine if the generator is faulty, or if EVR circuitry is defective.

TEST 2

- (1) Perform the previous test preparation.
- (2) Fully engage the parking brake.
- (3) Connect one end of a jumper wire to a good ground. Connect the other end of jumper wire to the generator field driver (-) terminal. The 2 field terminals (+ and -) are located on the back of the generator (Fig. 1) or (Fig. 2). To locate and identify the (-) terminal and circuit, refer to Group 8W, Wiring Diagrams. Another way to identify the (-) terminal is to start the engine and measure voltage at both field terminals. The (+) terminal will show battery voltage (12.5–14.5 volts). The (-) terminal will show 3–5 volts less than battery voltage.

CAUTION: Do not connect the jumper ground wire to the generator field source (+) field terminal. Damage to electrical system components may result.

Connecting the jumper wire will remove the voltage regulator circuitry from the test. It will also generate a Diagnostic Trouble Code (DTC).

- (4) Start engine. **Immediately** after starting, reduce engine speed to idle. This will prevent any electrical accessory damage from high voltage.

- (5) Adjust carbon pile rheostat (load) and engine speed in slow increments until a speed of 1250 rpm, and a voltmeter reading of 15 volts is obtained. Immediately record ammeter reading. Do not apply load to system longer than 15 seconds as damage to test equipment may result.

CAUTION: When adjusting rheostat load, do not allow voltage to rise above 16 volts. Damage to the battery and electrical system components may result.

- (6) The ammeter reading must meet the Minimum Test Amps specifications as displayed in the Generator Ratings chart. This can be found in the Specifications section at the end of this group. A label stating a part reference number is attached to the generator case. On some engines this label may be located on the bottom of the case. Compare this reference number to the Generator Rating chart.

- (7) Remove volt/amp tester.
- (8) Remove jumper wire.
- (9) Use the DRB scan tool to erase the DTC. Refer to the DRB screen for procedures.

RESULTS

- If amp reading meets specifications in Test 2, generator is OK.
- If amp reading is less than specified in Test 2, and wire resistance (voltage drop) tests were OK, the generator should be replaced. Refer to Removal and Installation in this group for procedures.
- If Test 2 results were OK, but Test 1 results were not, the problem is in EVR circuitry. Refer to appropriate Powertrain Diagnostic Procedures manual for diagnosis.

BATTERY TEMPERATURE SENSOR

To perform a complete test of this sensor and its circuitry, refer to the appropriate Powertrain Diagnostic Procedures manual. To test the sensor only, refer to the following:

- (1) The sensor is located under the battery and is attached to the battery tray (Fig. 3). A two-wire pigtail harness is attached directly to the sensor. The opposite end of this harness connects the sensor to the engine wiring harness.

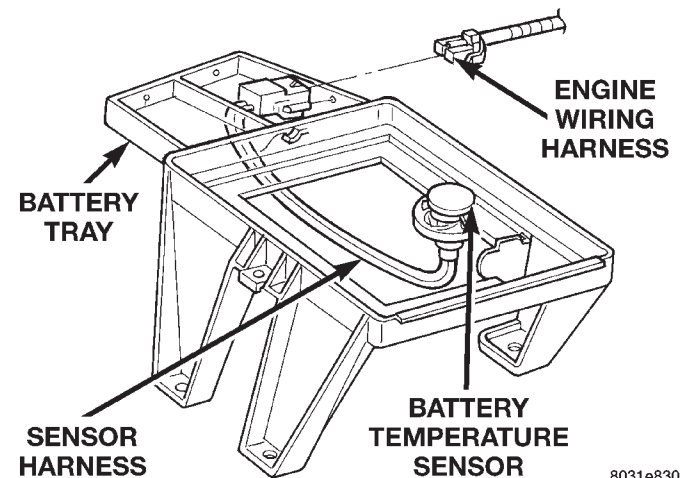


Fig. 3 Battery Temperature Sensor

- (2) Disconnect the two-wire pigtail harness from the engine harness.
- (3) Attach ohmmeter leads to the wire terminals of the pigtail harness.
- (4) At room temperature of 25° C (75–80° F), an ohmmeter reading of 9,000 (9K) to 11,000 (11K) ohms should be observed.
- (5) If reading is above or below the specification, replace the sensor.
- (6) Refer to the Removal and Installation section for procedures.

DIAGNOSIS AND TESTING (Continued)

ON-BOARD DIAGNOSTIC TEST FOR CHARGING SYSTEM

The Powertrain Control Module (PCM) monitors critical input and output circuits of the charging system, making sure they are operational. A Diagnostic Trouble Code (DTC) is assigned to each input and output circuit monitored by the On-Board Diagnostic (OBD) system. Some circuits are checked continuously and some are checked only under certain conditions.

For DTC information, refer to Diagnostic Trouble Codes in Group 25, Emission Control System. This will include a complete list of DTC's including DTC's for the charging system.

REMOVAL AND INSTALLATION

GENERATOR

REMOVAL

WARNING: DISCONNECT NEGATIVE CABLE FROM BATTERY BEFORE REMOVING BATTERY OUTPUT WIRE (B+ WIRE) FROM GENERATOR. FAILURE TO DO SO CAN RESULT IN INJURY OR DAMAGE TO ELECTRICAL SYSTEM.

- (1) Disconnect negative battery cable at battery.
- (2) Remove generator drive belt. Refer to Group 7, Cooling System for procedure.
- (3) Remove generator pivot and mounting bolts/nut (Fig. 4) or (Fig. 5). Position generator for access to wire connectors.

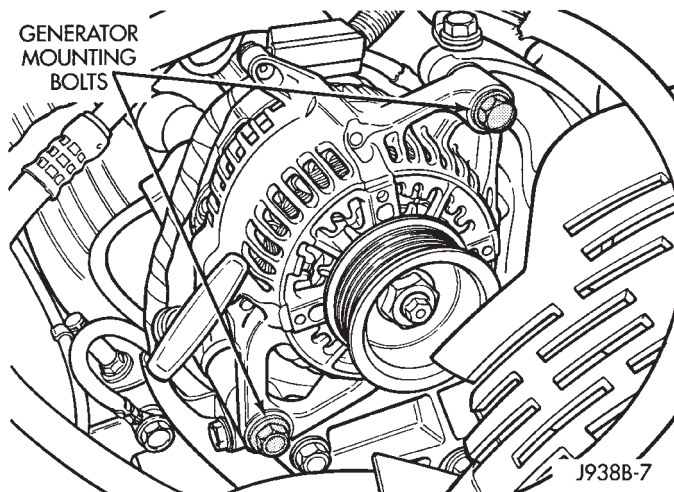


Fig. 4 Remove/Install Generator—5.2L/5.9L Engine

- (4) Remove nuts from harness holddown, battery terminal, ground terminal and 2 field terminals. Remove wire connectors. A typical generator wiring harness for 5.2L/5.9L engines is shown in (Fig. 6).

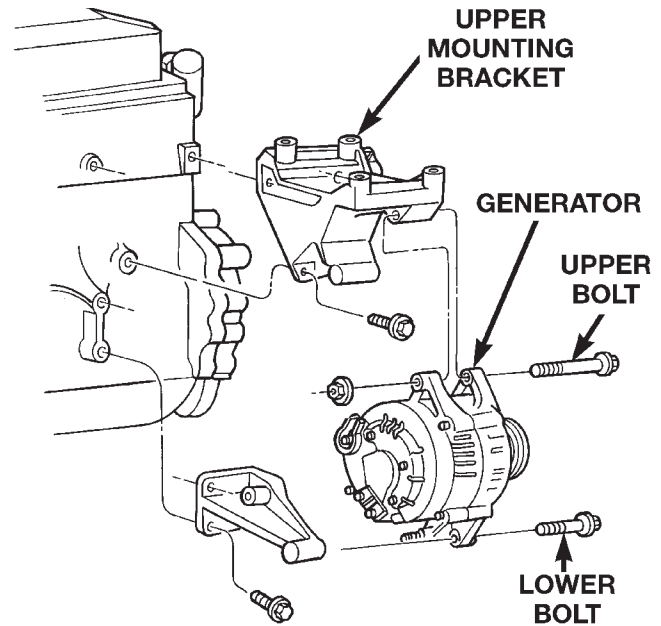


Fig. 5 Remove/Install Generator—4.0L Engine

A typical generator wiring harness for 4.0L engines is shown in (Fig. 7). Wiring harness routing as shown may be slightly different depending on vehicle model and/or engine. Refer to Group 8W, Wiring Diagrams for additional information.

- (5) Remove generator from vehicle.

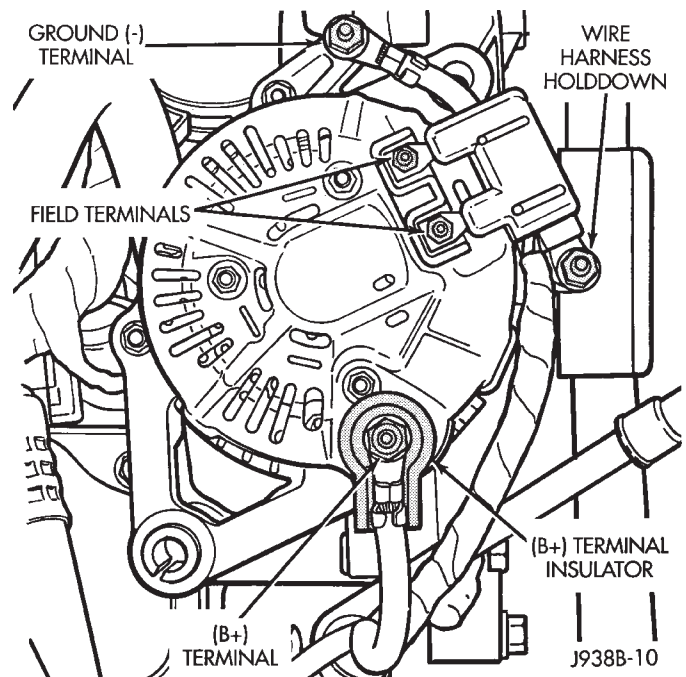


Fig. 6 Remove/Install Generator Connectors—5.2L/5.9L Engines—Typical

REMOVAL AND INSTALLATION (Continued)

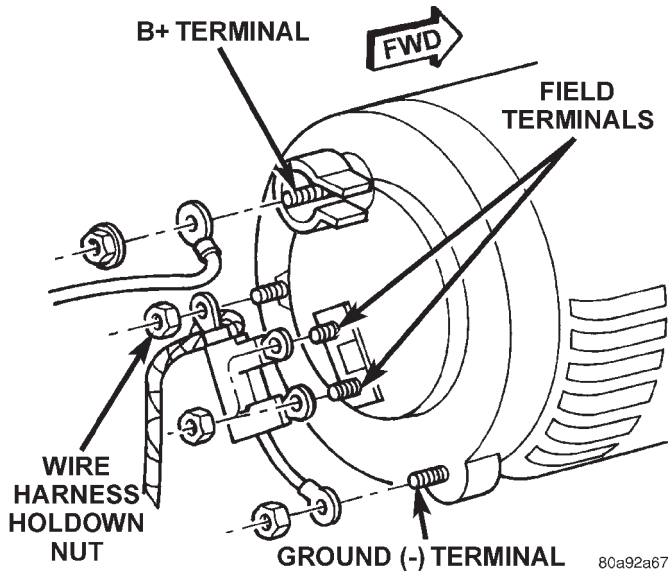


Fig. 7 Remove/Install Generator Connectors—4.0L Engine—Typical

INSTALLATION

(1) Position generator to engine and install wiring to rear of generator. Tighten all wiring fasteners to:

- Battery terminal nut—8.5 N·m (75 in. lbs.)
- Ground terminal nut—8.5 N·m (75 in. lbs.)
- Harness holddown nut—8.5 N·m (75 in. lbs.)
- Field terminal nuts—2.8 N·m (25 in. lbs.)

(2) Install generator mounting fasteners and tighten as follows:

- Generator mounting bolt 5.2L/5.9L engines—41 N·m (30 ft. lbs.)
- Generator pivot bolt/nut 5.2L/5.9L engines—41 N·m (30 ft. lbs.)
- Generator mounting bolt 4.0L engine—55 N·m (41 ft. lbs.)
- Generator pivot bolt/nut 4.0L engine—55 N·m (41 ft. lbs.)

CAUTION: Never force a belt over a pulley rim using a screwdriver. The synthetic fiber of the belt can be damaged.

CAUTION: When installing a serpentine accessory drive belt, the belt **MUST** be routed correctly. The

water pump will be rotating in the wrong direction if the belt is installed incorrectly, causing the engine to overheat. Refer to belt routing label in engine compartment, or refer to Belt Schematics in Group 7, Cooling System.

- (3) Install generator drive belt. Refer to Group 7, Cooling System for procedure.
- (4) Install negative battery cable to battery.

BATTERY TEMPERATURE SENSOR

The battery temperature sensor is located under vehicle battery (Fig. 8) and is attached to a mounting hole on battery tray.

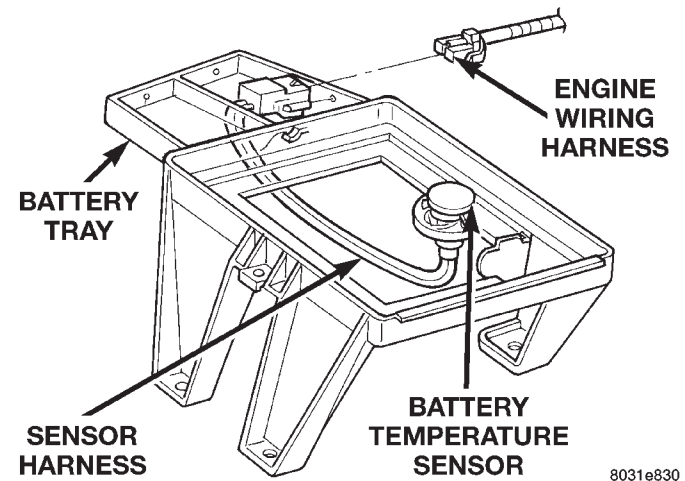


Fig. 8 Battery Temperature Sensor Location

REMOVAL

- (1) Remove battery. Refer to Group 8A, Battery for procedures.
- (2) Disconnect sensor pigtail harness from engine wire harness.
- (3) Pry sensor straight up from battery tray mounting hole.

INSTALLATION

- (1) Feed pigtail harness through hole in top of battery tray and press sensor into top of battery tray.
- (2) Connect pigtail harness.
- (3) Install battery. Refer to Group 8A, Battery for procedures.

SPECIFICATIONS**GENERATOR RATINGS**

TYPE	PART NUMBER	RATED SAE AMPS	ENGINES	MINIMUM TEST AMPS
DENSO	56005685	117	4.0L	88
DENSO	56005686	136	4.0L	95
DENSO	56027912	117	5.2L	90
DENSO	56027913	136	5.2L	100
DENSO	56041394AA	150	5.9L	125

TORQUE CHART

Description	Torque
Generator Mounting Bolt— 5.2L/5.9L Engines	41 N·m (30 ft. lbs.)
Generator Pivot Bolt/Nut— 5.2L/5.9L Engines	41 N·m (30 ft. lbs.)
Generator Mounting Bolt— 4.0L Engine	55 N·m (41 ft. lbs.)
Generator Pivot Bolt/Nut— 4.0L Engine	55 N·m (41 ft. lbs.)
Battery Terminal Nut	8.5 N·m (75 in. lbs.)
Ground Terminal Nut	8.5 N·m (75 in. lbs.)
Harness Hold-down Nut	8.5 N·m (75 in. lbs.)
Field Terminal Nuts	2.8 N·m (25 in. lbs.)

CHARGING SYSTEM

CONTENTS

	page		page
GENERAL INFORMATION		CHARGING SYSTEM RESISTANCE TESTS ...	3
OVERVIEW	1	CURRENT OUTPUT TEST	4
DESCRIPTION AND OPERATION		ON-BOARD DIAGNOSTIC TEST FOR	
BATTERY TEMPERATURE SENSOR	2	CHARGING SYSTEM	5
CHARGING SYSTEM OPERATION	1	REMOVAL AND INSTALLATION	
ELECTRONIC VOLTAGE REGULATOR	2	BATTERY TEMPERATURE SENSOR	7
GENERATOR	2	GENERATOR	6
DIAGNOSIS AND TESTING		SPECIFICATIONS	
BATTERY TEMPERATURE SENSOR	5	GENERATOR RATINGS	8
CHARGING SYSTEM	2	TORQUE CHART	8

GENERAL INFORMATION

OVERVIEW

The battery, starting, and charging systems operate with one another, and must be tested as a complete system. In order for the vehicle to start and charge properly, all of the components involved in these systems must perform within specifications.

Group 8A covers the battery, Group 8B covers the starting system, and Group 8C covers the charging system. Refer to Group 8W - Wiring Diagrams for complete circuit descriptions and diagrams. We have separated these systems to make it easier to locate the information you are seeking within this Service Manual. However, when attempting to diagnose any of these systems, it is important that you keep their interdependency in mind.

The diagnostic procedures used in these groups include the most basic conventional diagnostic methods to the more sophisticated On-Board Diagnostics (OBD) built into the Powertrain Control Module (PCM). Use of a induction milliampere ammeter, volt/ohmmeter, battery charger, carbon pile rheostat (load tester), and 12-volt test lamp may be required.

All OBD-sensed systems are monitored by the PCM. Each monitored circuit is assigned a Diagnostic Trouble Code (DTC). The PCM will store a DTC in electronic memory for any failure it detects. See the On-Board Diagnostics Test in Group 8C - Charging System for more information.

DESCRIPTION AND OPERATION

CHARGING SYSTEM OPERATION

The charging system consists of:

- Generator
- Electronic Voltage Regulator (EVR) circuitry within the Powertrain Control Module (PCM)
- Ignition switch (refer to Group 8D, Ignition System for information)
- Battery (refer to Group 8A, Battery for information)
- Battery temperature sensor
- Generator Lamp (if equipped)
- Check Gauges Lamp (if equipped)
- Voltmeter (refer to Group 8E, Instrument Panel and Gauges for information)
- Wiring harness and connections (refer to Group 8W, Wiring for information)

The charging system is turned on and off with the ignition switch. When the ignition switch is turned to the ON position, battery voltage from the powertrain control module (PCM) is supplied to the generator rotor to produce a magnetic field. This is done through one of the two field terminals at the rear of generator.

The amount of DC current produced by the generator is controlled by the EVR (field control) circuitry contained within the PCM. This circuitry is connected in series with the second rotor field terminal and ground.

A battery temperature sensor, located in the battery tray housing, is used to sense battery temperature. This temperature data, along with data from monitored line voltage, is used by the PCM to vary the battery charging rate. This is done by cycling the ground path to control the strength of the rotor mag-

DESCRIPTION AND OPERATION (Continued)

netic field. The PCM then compensates and regulates generator current output accordingly.

All vehicles are equipped with On-Board Diagnostics (OBD). All OBD-sensed systems, including EVR (field control) circuitry, are monitored by the PCM. Each monitored circuit is assigned a Diagnostic Trouble Code (DTC). The PCM will store a DTC in electronic memory for certain failures it detects. Refer to On-Board Diagnostics in Group 25, Emission Control System for more DTC information.

The Check Gauges Lamp (if equipped) monitors: **charging system voltage**, engine coolant temperature and engine oil pressure. If an extreme condition is indicated, the lamp will be illuminated. This is done as reminder to check the three gauges. The signal to activate the lamp is sent via the CCD bus circuits. The lamp is located on the instrument panel. Refer to Group 8E, Instrument Panel and Gauges for additional information.

GENERATOR

The generator is belt-driven by the engine using a serpentine type drive belt. It is serviced only as a complete assembly. If the generator fails for any reason, the entire assembly must be replaced.

As the energized rotor begins to rotate within the generator, the spinning magnetic field induces a current into the windings of the stator coil. Once the generator begins producing sufficient current, it also provides the current needed to energize the rotor.

The Y type stator winding connections deliver the induced AC current to 3 positive and 3 negative diodes for rectification. From the diodes, rectified DC current is delivered to the vehicle electrical system through the generator battery and ground terminals.

Although the generators appear the same externally, different generators with different output ratings are used on this vehicle. Be certain that the replacement generator has the same output rating and part number as the original unit. Refer to Generator Ratings in the Specifications section at the back of this group for amperage ratings and part numbers.

Noise emitting from the generator may be caused by: worn, loose or defective bearings; a loose or defective drive pulley; incorrect, worn, damaged or misadjusted fan drive belt; loose mounting bolts; a misaligned drive pulley or a defective stator or diode.

BATTERY TEMPERATURE SENSOR

The battery temperature sensor is used to determine the battery temperature and control battery charging rate. This temperature data, along with data from monitored line voltage, is used by the PCM to vary the battery charging rate. System voltage will

be higher at colder temperatures and is gradually reduced at warmer temperatures.

ELECTRONIC VOLTAGE REGULATOR

The Electronic Voltage Regulator (EVR) is not a separate component. It is actually a voltage regulating circuit located within the Powertrain Control Module (PCM). The EVR is not serviced separately. If replacement is necessary, the PCM must be replaced.

Operation: The amount of DC current produced by the generator is controlled by EVR circuitry contained within the PCM. This circuitry is connected in series with the generator's second rotor field terminal and its ground.

Voltage is regulated by cycling the ground path to control the strength of the rotor magnetic field. The EVR circuitry monitors system line voltage and battery temperature (refer to Battery Temperature Sensor for more information). It then compensates and regulates generator current output accordingly. Also refer to Charging System Operation for additional information.

DIAGNOSIS AND TESTING

CHARGING SYSTEM

The following procedures may be used to diagnose the charging system if:

- the generator lamp (if equipped) is illuminated with the engine running
- the voltmeter (if equipped) does not register properly
- an undercharged or overcharged battery condition occurs.

Remember that an undercharged battery is often caused by:

- accessories being left on with the engine not running
- a faulty or improperly adjusted switch that allows a lamp to stay on. See Ignition-Off Draw Test in Group 8A, Battery for more information.

INSPECTION

To perform a complete test of the charging system, refer to the appropriate Powertrain Diagnostic Procedures service manual and the DRB scan tool. Perform the following inspections before attaching the scan tool.

- (1) Inspect the battery condition. Refer to Group 8A, Battery for procedures.
- (2) Inspect condition of battery cable terminals, battery posts, connections at engine block, starter solenoid and relay. They should be clean and tight. Repair as required.
- (3) Inspect all fuses in both the fuseblock and Power Distribution Center (PDC) for tightness in

DIAGNOSIS AND TESTING (Continued)

receptacles. They should be properly installed and tight. Repair or replace as required.

(4) Inspect generator mounting bolts for tightness. Replace or tighten bolts if required. Refer to the Generator Removal/Installation section of this group for torque specifications.

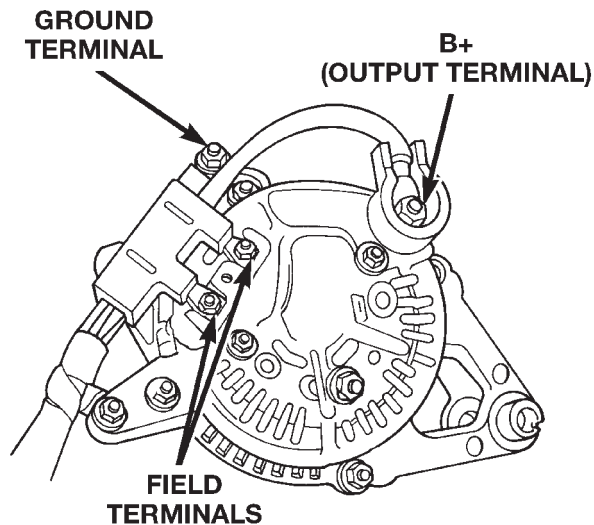
(5) Inspect generator drive belt condition and tension. Tighten or replace belt as required. Refer to Belt Tension Specifications in Group 7, Cooling System.

(6) Inspect automatic belt tensioner (if equipped). Refer to Group 7, Cooling System for information.

(7) Inspect connections at generator field, battery output, and ground terminals. Also check ground connection at engine. They should all be clean and tight. Repair as required.

CHARGING SYSTEM RESISTANCE TESTS

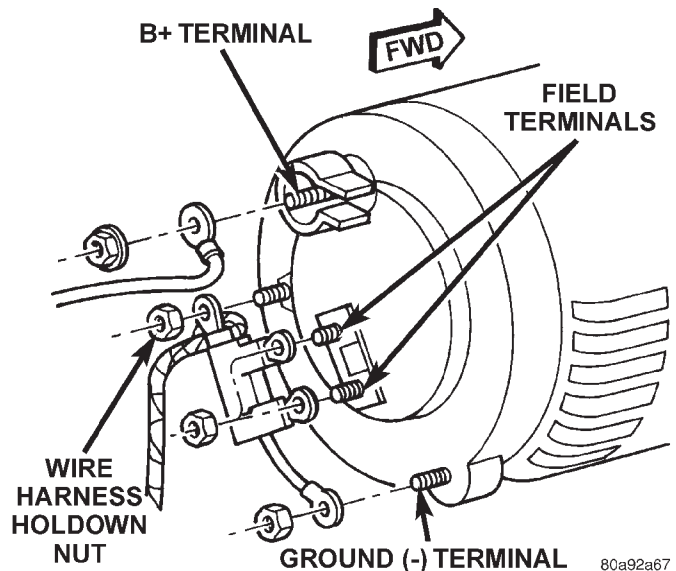
These tests will show the amount of voltage drop across the generator output wire, from the generator output (B+) terminal to the battery positive post. They will also show the amount of voltage drop from the ground (-) terminal on the generator to the battery negative post. Typical generator wiring harnesses are shown in (Fig. 1) or (Fig. 2). Wiring harness routing as shown may be slightly different depending on vehicle model and/or engine. Refer to Group 8W, Wiring Diagrams for additional information.



80a3cc69

Fig. 1 Generator Terminals (Typical Wiring Harness Shown)

A voltmeter with a 0–18 volt DC scale should be used for these tests. By repositioning the voltmeter



80a92a67

Fig. 2 Generator Terminals (Typical Wiring Harness Shown)

test leads, the point of high resistance (voltage drop) can easily be found.

PREPARATION

- (1) Before starting test, make sure battery is in good condition and is fully-charged. See Group 8A, Battery for more information.
- (2) Check condition of battery cables at battery. Clean if necessary.
- (3) Start the engine and allow it to reach normal operating temperature.
- (4) Shut engine off.
- (5) Connect an engine tachometer.
- (6) Fully engage the parking brake.

TEST

- (1) Start engine.
- (2) Place heater blower in high position.
- (3) Turn on headlamps and place in high-beam position.
- (4) Turn vehicle interior lamps on.
- (5) Bring engine speed up to 2400 rpm and hold.
- (6) Testing (+) circuitry:
 - (a) Touch the negative lead of voltmeter directly to battery positive post.
 - (b) Touch the positive lead of voltmeter to the B+ output terminal stud on the generator (not the terminal mounting nut). Voltage should be no higher than 0.6 volts. If voltage is higher than 0.6 volts, touch test lead to terminal mounting stud and then to the wiring connector. If voltage is now below 0.6 volts, look for dirty, loose or poor connection at this point. Also check condition of the generator output wire-to-battery bullet connector (if equipped). Refer to Group 8, Wiring for connec-

DIAGNOSIS AND TESTING (Continued)

tor location. A voltage drop test may be performed at each (+) connection in this circuit to locate the excessive resistance.

(7) Testing (-) circuitry:

(a) Touch the negative lead of voltmeter directly to battery negative post.

(b) Touch the positive lead of voltmeter to the ground terminal stud on the generator case (not the terminal mounting nut). Voltage should be no higher than 0.3 volts. If voltage is higher than 0.3 volts, touch test lead to terminal mounting stud nut and then to the wiring connector. If voltage is now below 0.3 volts, look for dirty, loose or poor connection at this point. A voltage drop test may be performed at each (-) connection in this circuit to locate the excessive resistance. This test can also be performed between the generator case and the engine. If test voltage is higher than 0.3 volts, check for corrosion at generator mounting points or loose generator mounting.

CURRENT OUTPUT TEST

The current output test will determine if the charging system can deliver its minimum test current (amperage) output. Refer to the Specifications section at the end of this group for minimum test current (amperage) requirements.

The first part of this test (Test 1) will determine the combined amperage output of both the generator and the Electronic Voltage Regulator (EVR) circuitry. The second part of this test (Test 2) will determine only generator amperage and **will not** include analysis of EVR circuitry. EVR circuitry is located within the Powertrain Control Module (PCM). To test voltage regulator circuitry, refer to the appropriate Powertrain Diagnostic Procedures service manual.

PREPARATION

(1) Determine if any Diagnostic Trouble Codes (DTC's) exist. To determine a DTC, refer to On-Board Diagnostics in this group. For repair, refer to the appropriate Powertrain Diagnostic Procedures manual.

(2) Before starting test, make sure battery is in good condition and is fully-charged. See Group 8A, Battery for more information.

(3) Check condition of battery cables at battery. Clean if necessary.

(4) Perform the previous Charging System Resistance Tests (voltage drop tests). This will ensure clean and tight generator/battery electrical connections.

(5) Be sure the generator drive belt is properly tensioned. Refer to Group 7, Cooling System for information.

(6) A volt/amp tester equipped with both a battery load control (carbon pile rheostat) and an inductive-

type pickup clamp (ammeter probe) will be used for this test. Refer to operating instructions supplied with tester. When using a tester equipped with an inductive-type clamp, removal of wiring at the generator will not be necessary.

(7) Start the engine and allow it to reach operating temperature.

(8) Shut engine off.

(9) Turn off all electrical accessories and all vehicle lighting.

(10) Connect the volt/amp tester leads to the battery. Be sure the carbon pile rheostat control is in the OPEN or OFF position before connecting leads. See Load Test in Group 8A, Battery for more information. Also refer to the operating instructions supplied with test equipment.

(11) Connect the inductive clamp (ammeter probe). Refer to the operating instructions supplied with test equipment.

(12) If volt/amp tester is not equipped with an engine tachometer, connect a separate tachometer to the engine.

TEST 1

(1) Perform the previous test Preparation.

(2) Fully engage the parking brake.

(3) Start engine.

(4) Bring engine speed to 2500 rpm.

(5) With engine speed held at 2500 rpm, slowly adjust the rheostat control (load) on the tester to obtain the highest amperage reading. Do not allow voltage to drop below 12 volts. Record the reading.

This load test must be performed within 15 seconds to prevent damage to test equipment. On certain brands of test equipment, this load will be applied automatically. Refer to the operating manual supplied with test equipment.

(6) The ammeter reading must meet the Minimum Test Amps specifications as displayed in the Generator Ratings chart. This can be found in the Specifications section at the end of this group. A label stating a part reference number is attached to the generator case. On some engines this label may be located on the bottom of the case. Compare this reference number to the Generator Ratings chart.

(7) Rotate the load control to the OFF position.

(8) Continue holding engine speed at 2500. If EVR circuitry is OK, amperage should drop below 15–20 amps. With all electrical accessories and vehicle lighting off, this could take several minutes of engine operation. If amperage did not drop, refer to the appropriate Powertrain Diagnostic Procedures manual for testing.

(9) Remove volt/amp tester.

If minimum amperage could not be met, proceed to Test 2. This test will determine if the generator is faulty, or if EVR circuitry is defective.

DIAGNOSIS AND TESTING (Continued)

TEST 2

- (1) Perform the previous test preparation.
- (2) Fully engage the parking brake.
- (3) Connect one end of a jumper wire to a good ground. Connect the other end of jumper wire to the generator field driver (-) terminal. The 2 field terminals (+ and -) are located on the back of the generator (Fig. 1) or (Fig. 2). To locate and identify the (-) terminal and circuit, refer to Group 8W, Wiring Diagrams. Another way to identify the (-) terminal is to start the engine and measure voltage at both field terminals. The (+) terminal will show battery voltage (12.5–14.5 volts). The (-) terminal will show 3–5 volts less than battery voltage.

CAUTION: Do not connect the jumper ground wire to the generator field source (+) field terminal. Damage to electrical system components may result.

Connecting the jumper wire will remove the voltage regulator circuitry from the test. It will also generate a Diagnostic Trouble Code (DTC).

(4) Start engine. **Immediately** after starting, reduce engine speed to idle. This will prevent any electrical accessory damage from high voltage.

(5) Adjust carbon pile rheostat (load) and engine speed in slow increments until a speed of 1250 rpm, and a voltmeter reading of 15 volts is obtained. Immediately record ammeter reading. Do not apply load to system longer than 15 seconds as damage to test equipment may result.

CAUTION: When adjusting rheostat load, do not allow voltage to rise above 16 volts. Damage to the battery and electrical system components may result.

(6) The ammeter reading must meet the Minimum Test Amps specifications as displayed in the Generator Ratings chart. This can be found in the Specifications section at the end of this group. A label stating a part reference number is attached to the generator case. On some engines this label may be located on the bottom of the case. Compare this reference number to the Generator Rating chart.

- (7) Remove volt/amp tester.
- (8) Remove jumper wire.
- (9) Use the DRB scan tool to erase the DTC. Refer to the DRB screen for procedures.

RESULTS

- If amp reading meets specifications in Test 2, generator is OK.
- If amp reading is less than specified in Test 2, and wire resistance (voltage drop) tests were OK, the generator should be replaced. Refer to Removal and Installation in this group for procedures.

- If Test 2 results were OK, but Test 1 results were not, the problem is in EVR circuitry. Refer to appropriate Powertrain Diagnostic Procedures manual for diagnosis.

BATTERY TEMPERATURE SENSOR

To perform a complete test of this sensor and its circuitry, refer to the appropriate Powertrain Diagnostic Procedures manual. To test the sensor only, refer to the following:

- (1) The sensor is located under the battery and is attached to the battery tray (Fig. 3). A two-wire pigtail harness is attached directly to the sensor. The opposite end of this harness connects the sensor to the engine wiring harness.

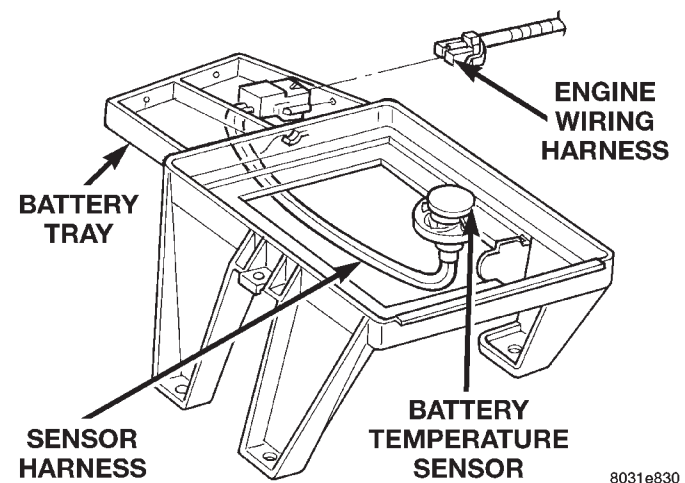


Fig. 3 Battery Temperature Sensor

- (2) Disconnect the two-wire pigtail harness from the engine harness.
- (3) Attach ohmmeter leads to the wire terminals of the pigtail harness.
- (4) At room temperature of 25° C (75–80° F), an ohmmeter reading of 9,000 (9K) to 11,000 (11K) ohms should be observed.
- (5) If reading is above or below the specification, replace the sensor.
- (6) Refer to the Removal and Installation section for procedures.

ON-BOARD DIAGNOSTIC TEST FOR CHARGING SYSTEM

The Powertrain Control Module (PCM) monitors critical input and output circuits of the charging system, making sure they are operational. A Diagnostic Trouble Code (DTC) is assigned to each input and output circuit monitored by the On-Board Diagnostic (OBD) system. Some circuits are checked continuously and some are checked only under certain conditions.

DIAGNOSIS AND TESTING (Continued)

For DTC information, refer to Diagnostic Trouble Codes in Group 25, Emission Control System. This will include a complete list of DTC's including DTC's for the charging system.

REMOVAL AND INSTALLATION

GENERATOR

REMOVAL

WARNING: DISCONNECT NEGATIVE CABLE FROM BATTERY BEFORE REMOVING BATTERY OUTPUT WIRE (B+ WIRE) FROM GENERATOR. FAILURE TO DO SO CAN RESULT IN INJURY OR DAMAGE TO ELECTRICAL SYSTEM.

- (1) Disconnect negative battery cable at battery.
- (2) Remove generator drive belt. Refer to Group 7, Cooling System for procedure.
- (3) Remove generator pivot and mounting bolts/nut (Fig. 4) or (Fig. 5). Position generator for access to wire connectors.

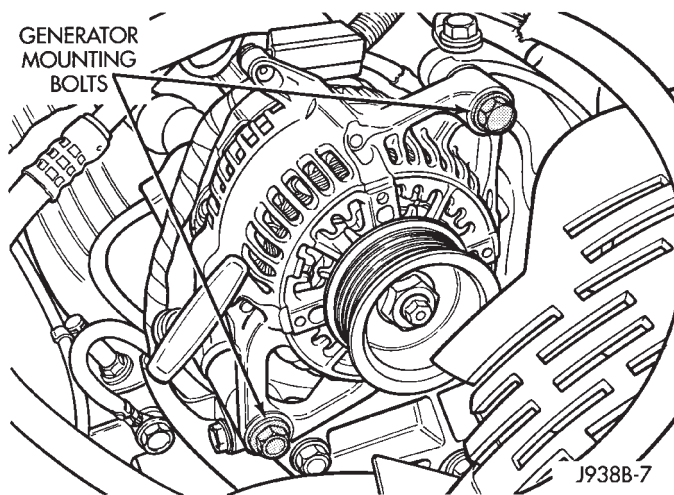


Fig. 4 Remove/Install Generator—5.2L/5.9L Engine

(4) Remove nuts from harness holddown, battery terminal, ground terminal and 2 field terminals. Remove wire connectors. A typical generator wiring harness for 5.2L/5.9L engines is shown in (Fig. 6). A typical generator wiring harness for 4.0L engines is shown in (Fig. 7). Wiring harness routing as shown may be slightly different depending on vehicle model and/or engine. Refer to Group 8W, Wiring Diagrams for additional information.

- (5) Remove generator from vehicle.

INSTALLATION

- (1) Position generator to engine and install wiring to rear of generator. Tighten all wiring fasteners to:
 - Battery terminal nut—8.5 N·m (75 in. lbs.)

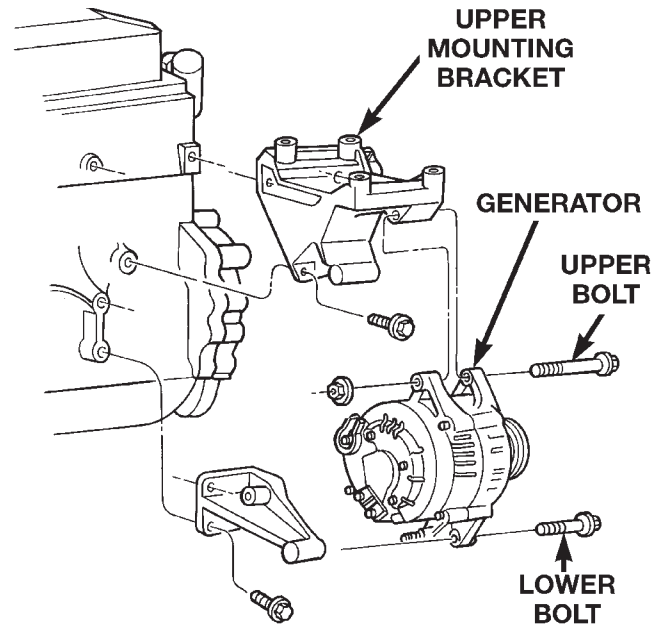


Fig. 5 Remove/Install Generator—4.0L Engine

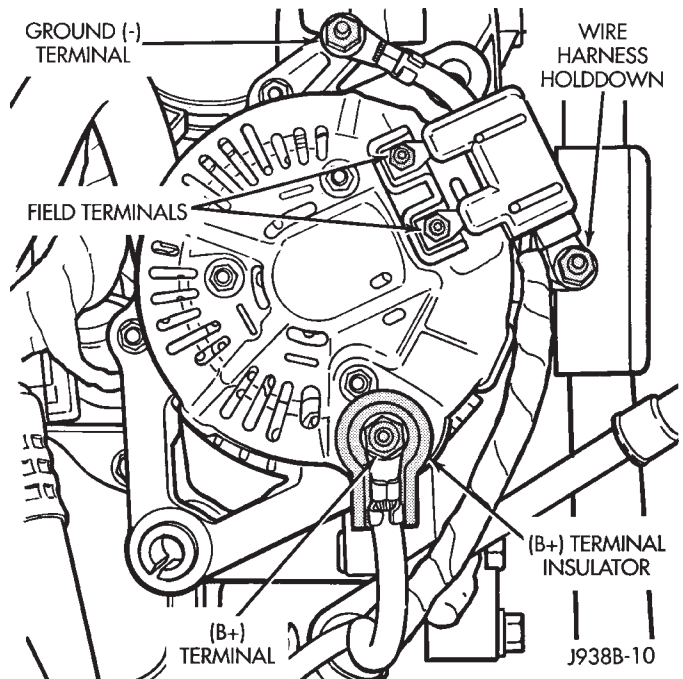


Fig. 6 Remove/Install Generator Connectors—5.2L/5.9L Engines—Typical

- Ground terminal nut—8.5 N·m (75 in. lbs.)
 - Harness holddown nut—8.5 N·m (75 in. lbs.)
 - Field terminal nuts—2.8 N·m (25 in. lbs.)
- (2) Install generator mounting fasteners and tighten as follows:
 - Generator mounting bolt 5.2L/5.9L engines—41 N·m (30 ft. lbs.)
 - Generator pivot bolt/nut 5.2L/5.9L engines—41 N·m (30 ft. lbs.)

REMOVAL AND INSTALLATION (Continued)

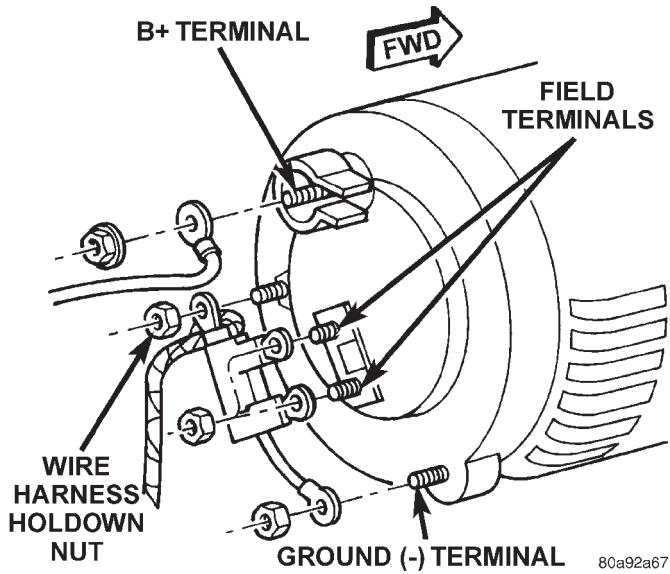


Fig. 7 Remove/Install Generator Connectors—4.0L Engine—Typical

- Generator mounting bolt 4.0L engine—55 N·m (41 ft. lbs.)
- Generator pivot bolt/nut 4.0L engine—55 N·m (41 ft. lbs.)

CAUTION: Never force a belt over a pulley rim using a screwdriver. The synthetic fiber of the belt can be damaged.

CAUTION: When installing a serpentine accessory drive belt, the belt **MUST** be routed correctly. The water pump will be rotating in the wrong direction if the belt is installed incorrectly, causing the engine to overheat. Refer to belt routing label in engine compartment, or refer to Belt Schematics in Group 7, Cooling System.

- (3) Install generator drive belt. Refer to Group 7, Cooling System for procedure.
- (4) Install negative battery cable to battery.

BATTERY TEMPERATURE SENSOR

The battery temperature sensor is located under vehicle battery (Fig. 8) and is attached to a mounting hole on battery tray.

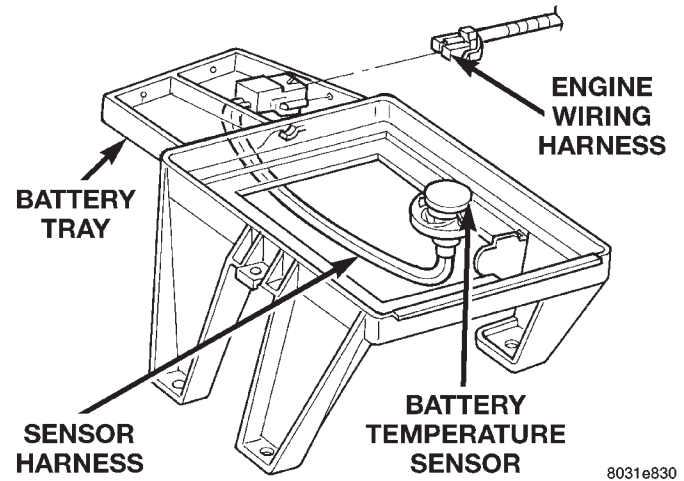


Fig. 8 Battery Temperature Sensor Location

REMOVAL

- (1) Remove battery. Refer to Group 8A, Battery for procedures.
- (2) Disconnect sensor pigtail harness from engine wire harness.
- (3) Pry sensor straight up from battery tray mounting hole.

INSTALLATION

- (1) Feed pigtail harness through hole in top of battery tray and press sensor into top of battery tray.
- (2) Connect pigtail harness.
- (3) Install battery. Refer to Group 8A, Battery for procedures.

SPECIFICATIONS**GENERATOR RATINGS**

TYPE	PART NUMBER	RATED SAE AMPS	ENGINES	MINIMUM TEST AMPS
DENSO	56005685	117	4.0L	88
DENSO	56005686	136	4.0L	95
DENSO	56027912	117	5.2L	90
DENSO	56027913	136	5.2L	100
DENSO	56041394AA	150	5.9L	125

TORQUE CHART

Description	Torque
Generator Mounting Bolt— 5.2L/5.9L Engines	41 N·m (30 ft. lbs.)
Generator Pivot Bolt/Nut— 5.2L/5.9L Engines	41 N·m (30 ft. lbs.)
Generator Mounting Bolt—4.0L Engine	55 N·m (41 ft. lbs.)
Generator Pivot Bolt/Nut—4.0L Engine	55 N·m (41 ft. lbs.)
Battery Terminal Nut	8.5 N·m (75 in. lbs.)
Ground Terminal Nut	8.5 N·m (75 in. lbs.)
Harness Hold-down Nut	8.5 N·m (75 in. lbs.)
Field Terminal Nuts	2.8 N·m (25 in. lbs.)

IGNITION SYSTEM

CONTENTS

	page		page
GENERAL INFORMATION		SPARK PLUG CABLES	9
INTRODUCTION	2	SPARK PLUG CONDITIONS	9
DESCRIPTION AND OPERATION		TESTING FOR SPARK AT COIL	5
AUTOMATIC SHUTDOWN (ASD) RELAY	3	REMOVAL AND INSTALLATION	
CAMSHAFT POSITION SENSOR	4	AUTOMATIC SHUTDOWN (ASD) RELAY	14
CRANKSHAFT POSITION SENSOR—		CAMSHAFT POSITION SENSOR	16
4.0L ENGINE	3	CRANKSHAFT POSITION SENSOR—	
CRANKSHAFT POSITION SENSOR—		4.0L ENGINE	15
5.2L/5.9L V-8 ENGINES	3	CRANKSHAFT POSITION SENSOR—	
DISTRIBUTOR	2	5.2L/5.9L ENGINES	15
ENGINE COOLANT TEMPERATURE SENSOR ...	4	DISTRIBUTOR—4.0L ENGINE	18
IGNITION COIL	3	DISTRIBUTOR—5.2L/5.9L ENGINES	16
IGNITION SWITCH AND KEY		ENGINE COOLANT TEMPERATURE	
LOCK CYLINDER	4	SENSOR	16
IGNITION SYSTEM	2	IGNITION COIL—4.0L ENGINE	14
INTAKE MANIFOLD AIR TEMPERATURE		IGNITION COIL—5.2L/5.9L ENGINES	13
SENSOR	4	IGNITION SWITCH AND KEY CYLINDER	21
MANIFOLD ABSOLUTE PRESSURE (MAP)		INTAKE MANIFOLD AIR TEMPERATURE	
SENSOR	4	SENSOR	16
POWERTRAIN CONTROL MODULE (PCM)	2	MANIFOLD ABSOLUTE PRESSURE	
SPARK PLUG CABLES	3	(MAP) SENSOR	16
SPARK PLUGS	3	POWERTRAIN CONTROL MODULE (PCM) ...	21
THROTTLE POSITION SENSOR	4	SHIFTER/IGNITION INTERLOCK	23
DIAGNOSIS AND TESTING		SPARK PLUG CABLES	12
AUTOMATIC SHUTDOWN (ASD)		SPARK PLUGS	12
RELAY TEST	4	THROTTLE POSITION SENSOR	16
CAMSHAFT POSITION SENSOR	8	SPECIFICATIONS	
CRANKSHAFT POSITION SENSOR	8	ENGINE FIRING ORDER—4.0L 6-CYLINDER	
DISTRIBUTOR CAP	7	ENGINE	24
DISTRIBUTOR ROTOR	7	ENGINE FIRING ORDER—5.2L/5.9L V-8	
ENGINE COOLANT TEMPERATURE		ENGINES	24
SENSOR	8	IGNITION COIL RESISTANCE	25
FAILURE TO START TEST	6	IGNITION TIMING	24
IGNITION COIL TEST	5	SPARK PLUG CABLE RESISTANCE	25
IGNITION TIMING	7	SPARK PLUGS	25
INTAKE MANIFOLD AIR TEMPERATURE		TORQUE CHART	25
SENSOR	8	VECI LABEL	24
MAP SENSOR	8		

GENERAL INFORMATION

INTRODUCTION

This group describes the ignition systems for 5.2L/5.9L V-8 and 4.0L 6-cylinder engines.

On Board Diagnostics is described in Group 25, Emission Control Systems.

Group 0, Lubrication and Maintenance, contains general maintenance information (in time or mileage intervals) for ignition related items. The Owner's Manual also contains maintenance information.

DESCRIPTION AND OPERATION

IGNITION SYSTEM

The ignition systems used on 5.2L/5.9L V-8 and 4.0L 6-cylinder engines are basically identical. Similarities and differences between the systems will be discussed.

The ignition system is controlled by the powertrain control module (PCM) on all engines.

The ignition system consists of:

- Spark Plugs
- Ignition Coil
- Secondary Ignition Cables
- Distributor (contains rotor and camshaft position sensor)
- Powertrain Control Module (PCM)
- Crankshaft Position, Camshaft Position, Throttle Position and MAP Sensors

POWERTRAIN CONTROL MODULE (PCM)

The Powertrain Control Module (PCM) is located in the engine compartment (Fig. 1).

The ignition system is controlled by the PCM.

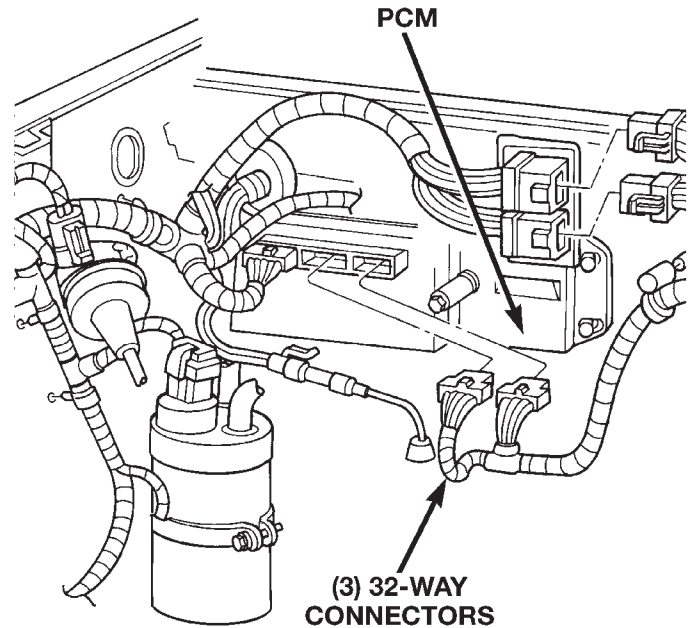
NOTE: Base ignition timing by rotation of distributor is not adjustable.

The PCM opens and closes the ignition coil ground circuit to operate the ignition coil. This is done to adjust ignition timing, both initial (base) and advance, and for changing engine operating conditions.

The amount of electronic spark advance provided by the PCM is determined by five input factors: engine coolant temperature, engine rpm, intake manifold temperature, manifold absolute pressure and throttle position.

DISTRIBUTOR

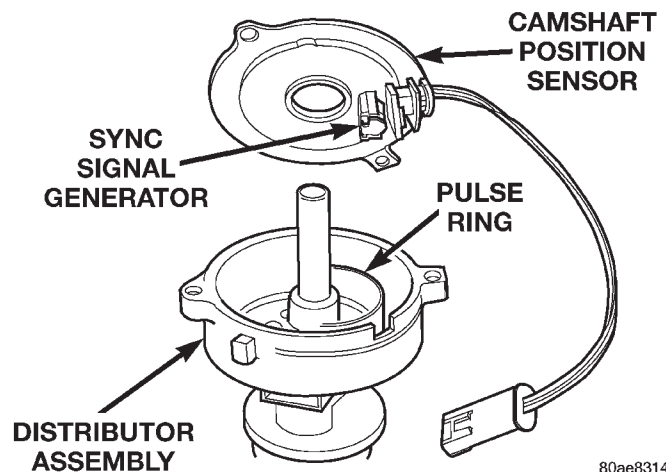
All 4.0L/5.2L/5.9L engines are equipped with a camshaft driven mechanical distributor containing a shaft driven distributor rotor. All distributors are equipped with an internal camshaft position (fuel



80a01300

Fig. 1 Powertrain Control Module (PCM) Location

sync) sensor (Fig. 2). This sensor provides fuel injection synchronization and cylinder identification.



80ae8314

Fig. 2 Distributor and Camshaft Position Sensor—Typical (5.2L/5.9L Shown)

The distributor does not have built in centrifugal or vacuum assisted advance. Base ignition timing and all timing advance is controlled by the powertrain control module (PCM). Because ignition timing is controlled by the PCM, **base ignition timing is not adjustable on any of these engines.**

On the 4.0L 6-cylinder engine, the distributor is locked in place by a fork with a slot located on the distributor housing base. The distributor holddown clamp bolt passes through this slot when installed. Because the distributor position is locked when installed, its rotational position can not be changed.

DESCRIPTION AND OPERATION (Continued)

Do not attempt to modify the distributor housing to get distributor rotation. Distributor position will have no effect on ignition timing. The position of the distributor will determine fuel synchronization only.

All 4.0L/5.2L/5.9L distributors contain an internal oil seal that prevents oil from entering the distributor housing. The seal is not serviceable.

SPARK PLUGS

All engines use resistor type spark plugs. Remove the spark plugs and examine them for burned electrodes and fouled, cracked or broken porcelain insulators. Keep plugs arranged in the order in which they were removed from the engine. A single plug displaying an abnormal condition indicates that a problem exists in the corresponding cylinder. Replace spark plugs at the intervals recommended in Group O, Lubrication and Maintenance

Spark plugs that have low milage may be cleaned and reused if not otherwise defective, carbon or oil fouled. Refer to the Spark Plug Condition section of this group.

SPARK PLUG CABLES

Spark plug cables are sometimes referred to as secondary ignition wires. These cables transfer electrical current from the ignition coil(s) and/or distributor, to individual spark plugs at each cylinder. The resistive spark plug cables are of nonmetallic construction. The cables provide suppression of radio frequency emissions from the ignition system.

IGNITION COIL

Battery voltage is supplied to the ignition coil positive terminal from the ASD relay.

The Powertrain Control Module (PCM) opens and closes the ignition coil ground circuit for ignition coil operation.

Base ignition timing is not adjustable on any engine. By controlling the coil ground circuit, the PCM is able to set the base timing and adjust the ignition timing advance. This is done to meet changing engine operating conditions.

The ignition coil is not oil filled. The windings are embedded in an epoxy compound. This provides heat and vibration resistance that allows the ignition coil to be mounted on the engine.

AUTOMATIC SHUTDOWN (ASD) RELAY

As one of its functions, the ASD relay will supply battery voltage to the ignition coil. The ground circuit for the ASD relay is controlled by the Powertrain Control Module (PCM). The PCM regulates ASD relay operation by switching the ground circuit on-and-off.

CRANKSHAFT POSITION SENSOR—5.2L/5.9L V-8 ENGINES

Engine speed and crankshaft position are provided through the crankshaft position sensor. The sensor generates pulses that are the input sent to the Powertrain Control Module (PCM). The PCM interprets the sensor input to determine the crankshaft position. The PCM then uses this position, along with other inputs, to determine injector sequence and ignition timing.

The sensor is a hall effect device combined with an internal magnet. It is also sensitive to steel within a certain distance from it.

On 5.2L/5.9L V-8 engines, the flywheel/drive plate has 8 single notches, spaced every 45 degrees, at its outer edge (Fig. 3).

The notches cause a pulse to be generated when they pass under the sensor. The pulses are the input to the PCM. For each engine revolution, there are 8 pulses generated on V-8 engines.

The engine will not operate if the PCM does not receive a crankshaft position sensor input.

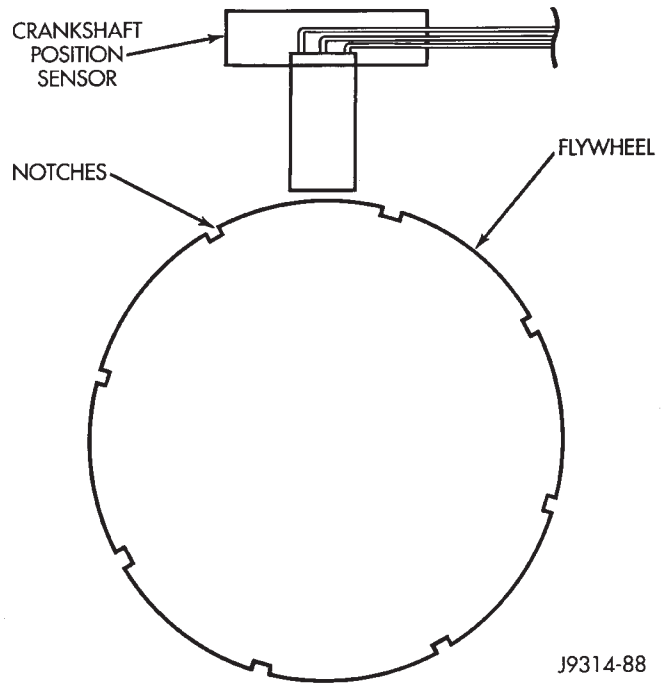


Fig. 3 Sensor Operation—5.2L/5.9L Engines

CRANKSHAFT POSITION SENSOR—4.0L ENGINE

Engine speed and crankshaft position are provided through the crankshaft position sensor. The sensor generates pulses that are the input sent to the powertrain control module (PCM). The PCM interprets the sensor input to determine the crankshaft position. The PCM then uses this position, along with other inputs, to determine injector sequence and ignition timing.

DESCRIPTION AND OPERATION (Continued)

The sensor is a hall effect device combined with an internal magnet. It is also sensitive to steel within a certain distance from it.

On 4.0L 6-cylinder engines, the flywheel/drive plate has 3 sets of four notches at its outer edge (Fig. 4).

The notches cause a pulse to be generated when they pass under the sensor. The pulses are the input to the PCM. For each engine revolution there are 3 sets of four pulses generated.

The trailing edge of the fourth notch, which causes the pulse, is four degrees before top dead center (TDC) of the corresponding piston.

The engine will not operate if the PCM does not receive a crankshaft position sensor input.

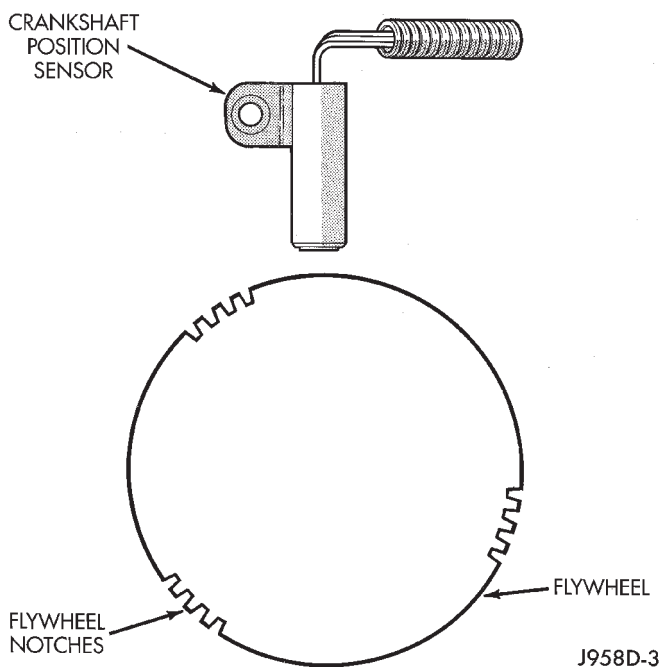


Fig. 4 Sensor Operation—4.0L 6-Cyl. Engine

CAMSHAFT POSITION SENSOR

The camshaft position sensor is located in the distributor on all engines.

The sensor contains a hall effect device called a sync signal generator to generate a fuel sync signal. This sync signal generator detects a rotating pulse ring (shutter) on the distributor shaft. The pulse ring rotates 180 degrees through the sync signal generator. Its signal is used in conjunction with the crankshaft position sensor to differentiate between fuel injection and spark events. It is also used to synchronize the fuel injectors with their respective cylinders.

When the leading edge of the pulse ring (shutter) enters the sync signal generator, the following occurs: The interruption of magnetic field causes the voltage to switch high resulting in a sync signal of approximately 5 volts.

When the trailing edge of the pulse ring (shutter) leaves the sync signal generator, the following occurs: The change of the magnetic field causes the sync signal voltage to switch low to 0 volts.

MANIFOLD ABSOLUTE PRESSURE (MAP) SENSOR

For an operational description, diagnosis and removal/installation procedures, refer to Group 14, Fuel System.

ENGINE COOLANT TEMPERATURE SENSOR

For an operational description, diagnosis and removal/installation procedures, refer to Group 14, Fuel System.

THROTTLE POSITION SENSOR

For an operational description, diagnosis and removal/installation procedures, refer to Group 14, Fuel System.

INTAKE MANIFOLD AIR TEMPERATURE SENSOR

For an operational description, diagnosis and removal/installation procedures, refer to Group 14, Fuel System.

IGNITION SWITCH AND KEY LOCK CYLINDER

The ignition switch is located on the steering column. The Key-In-Switch is located in the ignition switch module. For electrical diagnosis of the Key-In-Switch, refer to Group 8U, Chime/Buzzer Warning Systems. For removal/installation of either the key lock cylinder or ignition switch, refer to Ignition Switch and Key Cylinder Removal/Installation in this group.

On vehicles equipped with an automatic transmission, a cable connects an interlock device within the steering column assembly to the transmission floor shift lever. This interlock device is used to lock the transmission shifter in the PARK position when the key is in the LOCKED or ACCESSORY position. The interlock device is not serviceable. If repair is necessary, the steering column assembly must be replaced. Refer to Group 19, Steering for procedures. The shifter interlock cable can be adjusted or replaced. Refer to Group 21, Transmissions for procedures.

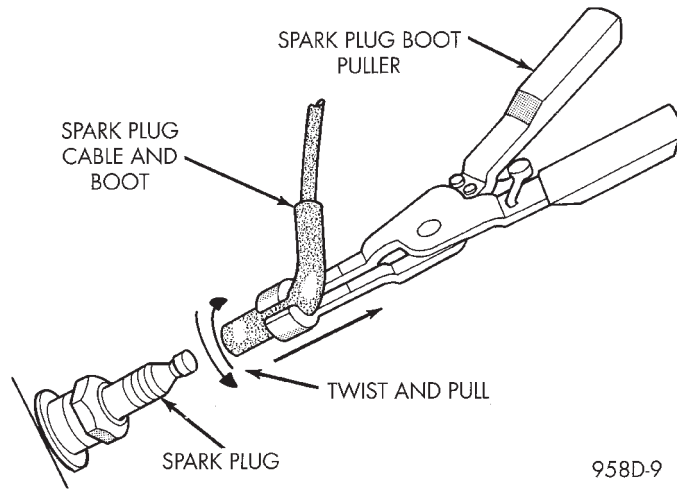
DIAGNOSIS AND TESTING**AUTOMATIC SHUTDOWN (ASD) RELAY TEST**

To perform a complete test of this relay and its circuitry, refer to the DRB scan tool. Also refer to the appropriate Powertrain Diagnostics Procedures manual. To test the relay only, refer to Relays—Operation/Testing in the Group 14, Fuel Systems section.

DIAGNOSIS AND TESTING (Continued)

TESTING FOR SPARK AT COIL

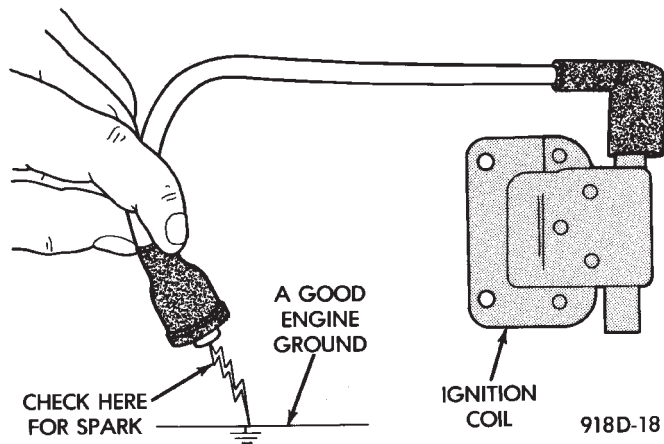
CAUTION: When disconnecting a high voltage cable from a spark plug or from the distributor cap, twist the rubber boot slightly (1/2 turn) to break it loose (Fig. 5). Grasp the boot (not the cable) and pull it off with a steady, even force.



958D-9

Fig. 5 Cable Removal

(1) Disconnect the ignition coil secondary cable from center tower of the distributor cap. Hold the cable terminal approximately 12 mm (1/2 in.) from a good engine ground (Fig. 6).



918D-18

Fig. 6 Checking for Spark—Typical

WARNING: BE VERY CAREFUL WHEN THE ENGINE IS CRANKING. DO NOT PUT YOUR HANDS NEAR THE PULLEYS, BELTS OR THE FAN. DO NOT WEAR LOOSE FITTING CLOTHING.

(2) Rotate (crank) the engine with the starter motor and observe the cable terminal for a steady arc. If steady arcing does not occur, inspect the secondary coil cable. Refer to Spark Plug Cables in this group. Also inspect the distributor cap and rotor for cracks or burn marks. Repair as necessary. If steady arcing occurs, connect ignition coil cable to the distributor cap.

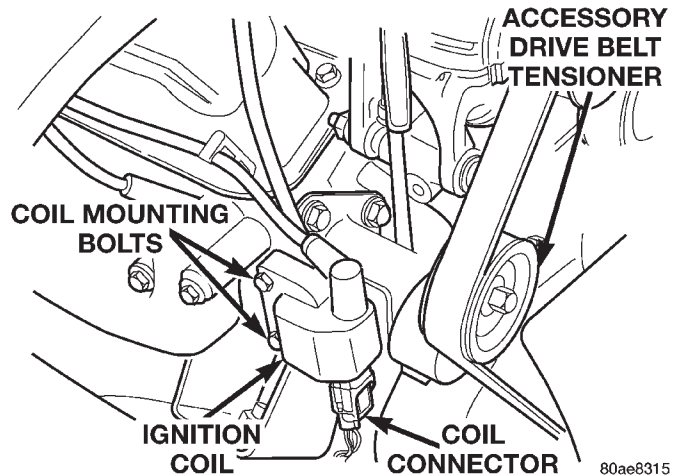
(3) Remove a cable from one spark plug.

(4) Using insulated pliers, hold the cable terminal approximately 12 mm (1/2 in.) from the engine cylinder head or block while rotating the engine with the starter motor. Observe the spark plug cable terminal for an arc. If steady arcing occurs, it can be expected that the ignition secondary system is operating correctly. **(If the ignition coil cable is removed for this test, instead of a spark plug cable, the spark intensity will be much higher).** If steady arcing occurs at the spark plug cables, but the engine will not start, connect the DRB scan tool. Refer to the appropriate Powertrain Diagnostic Procedures service manual.

IGNITION COIL TEST

To perform a complete test of the ignition coil and its circuitry, refer to the DRB scan tool. Also refer to the appropriate Powertrain Diagnostics Procedures manual. To test the coil only, refer to the following:

The ignition coil (Fig. 7) is designed to operate without an external ballast resistor.



80ae8315

Fig. 7 Ignition Coil—Typical (5.2L/5.9L Shown)

DIAGNOSIS AND TESTING (Continued)

IGNITION COIL RESISTANCE

COIL MANUFACTURER	PRIMARY RESISTANCE 21-27°C (70-80°F)	SECONDARY RESISTANCE 21-27°C (70-80°F)
Diamond	0.97 - 1.18 Ohms	11,300 - 15,300 Ohms
Toyodenso	0.95 - 1.20 Ohms	11,300 - 13,300 Ohms

Inspect the ignition coil for arcing. Test the coil according to coil tester manufacturer's instructions. Test the coil primary and secondary resistance. Replace any coil that does not meet specifications. Refer to the IGNITION COIL RESISTANCE chart.

If the ignition coil is being replaced, the secondary spark plug cable must also be checked. Replace cable if it has been burned or damaged.

Arcing at the tower will carbonize the cable boot, which if it is connected to a new ignition coil, will cause the coil to fail.

If the secondary coil cable shows any signs of damage, it should be replaced with a new cable and new terminal. Carbon tracking on the old cable can cause arcing and the failure of a new ignition coil.

FAILURE TO START TEST

To prevent unnecessary diagnostic time and wrong test results, the Testing For Spark At Coil test should be performed prior to this test.

WARNING: SET PARKING BRAKE OR BLOCK THE DRIVE WHEELS BEFORE PROCEEDING WITH THIS TEST.

(1) Unplug the ignition coil harness connector at the coil.

(2) Connect a set of small jumper wires (18 gauge or smaller) between the disconnected harness terminals and the ignition coil terminals. To determine polarity at connector and coil, refer to the Wiring Diagrams section.

(3) Attach one lead of a voltmeter to the positive (12 volt) jumper wire. Attach the negative side of voltmeter to a good ground. Determine that sufficient battery voltage (12.4 volts) is present for the starting and ignition systems.

(4) Determine that sufficient battery voltage (12.4 volts) is present for the starting and ignition systems.

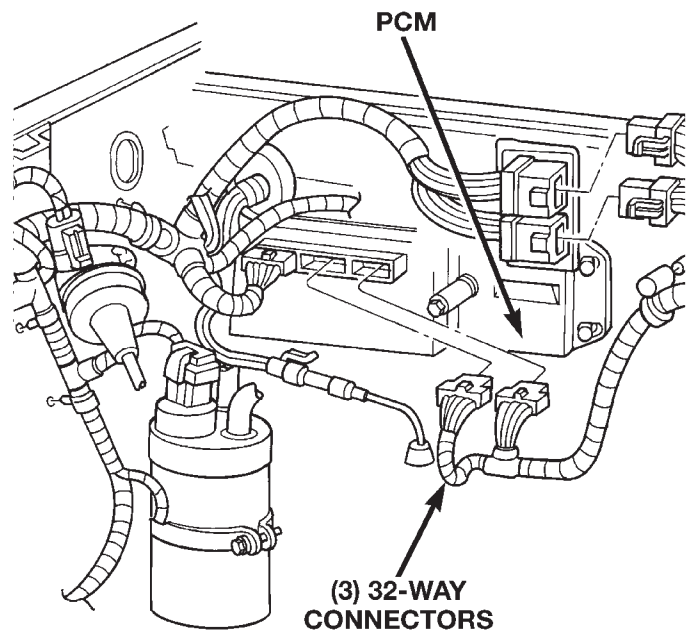
(5) Crank the engine for 5 seconds while monitoring the voltage at the coil positive terminal:

- If the voltage remains near zero during the entire period of cranking, refer to On-Board Diagnostics in Group 14, Fuel Systems. Check the Powertrain Control Module (PCM) and auto shutdown relay.

- If voltage is at or near battery voltage and drops to zero after 1-2 seconds of cranking, check the pow-

ertrain control module circuit. Refer to On-Board Diagnostics in Group 14, Fuel Systems.

- If voltage remains at or near battery voltage during the entire 5 seconds, turn the key off. Remove the three 32-way connectors (Fig. 8) from the PCM. Check 32-way connectors for any spread terminals or corrosion.



80a01300

Fig. 8 PCM and Three 32-Way Connectors

(6) Remove test lead from the coil positive terminal. Connect an 18 gauge jumper wire between the battery positive terminal and the coil positive terminal.

(7) Make the special jumper shown in (Fig. 9). Using the jumper, **momentarily** ground the ignition coil driver circuit at the PCM connector (cavity A-7). For cavity/terminal location of this circuit, refer to Group 8W, Wiring. A spark should be generated at the coil cable when the ground is removed.

(8) If spark is generated, replace the PCM.

(9) If spark is not seen, use the special jumper to ground the coil negative terminal directly.

(10) If spark is produced, repair wiring harness for an open condition.

(11) If spark is not produced, replace the ignition coil.

DIAGNOSIS AND TESTING (Continued)

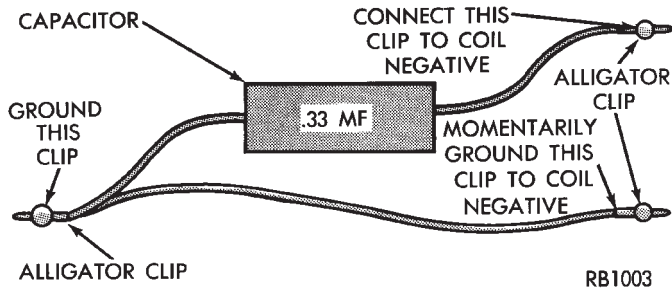


Fig. 9 Special Jumper Ground-to-Coil Negative Terminal

DISTRIBUTOR CAP

Remove the distributor cap and wipe it clean with a dry lint free cloth. Visually inspect the cap for cracks, carbon paths, broken towers or damaged rotor button (Fig. 10) or (Fig. 11). Also check for white deposits on the inside (caused by condensation entering the cap through cracks). Replace any cap that displays charred or eroded terminals. The machined surface of a terminal end (faces toward rotor) will indicate some evidence of erosion from normal operation. Examine the terminal ends for evidence of mechanical interference with the rotor tip.

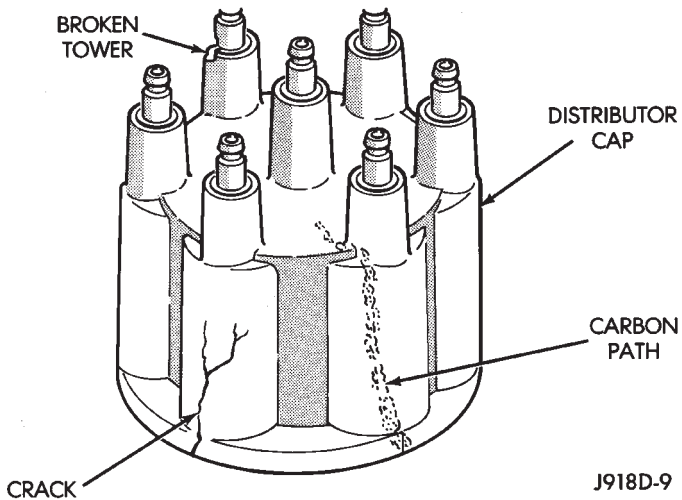


Fig. 10 Cap Inspection—External—Typical

DISTRIBUTOR ROTOR

Visually inspect the rotor (Fig. 12) for cracks, evidence of corrosion or the effects of arcing on the metal tip. Also check for evidence of mechanical interference with the cap. Some charring is normal on the end of the metal tip. The silicone-dielectric-varnish-compound applied to the rotor tip for radio interference noise suppression, will appear charred. This is normal. **Do not remove the charred compound.** Test the spring for insufficient tension. Replace a rotor that displays any of these adverse conditions.

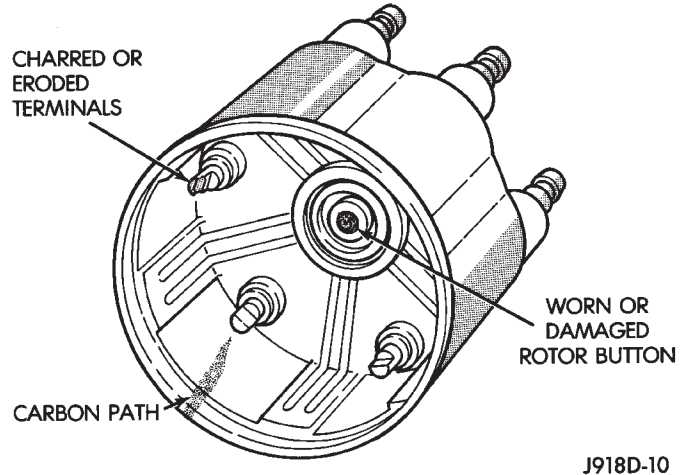


Fig. 11 Cap Inspection—Internal—Typical

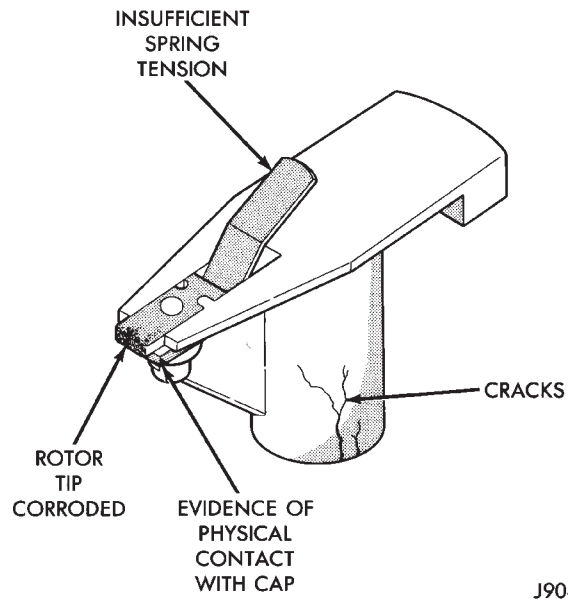


Fig. 12 Rotor Inspection—Typical

IGNITION TIMING

NOTE: Base (initial) ignition timing is NOT adjustable on any 4.0L/5.2L/5.9L engine. Do not attempt to adjust ignition timing by rotating the distributor.

NOTE: On 4.0L 6-cylinder engines, do not attempt to modify the slotted fork on the distributor housing to get distributor rotation. Distributor position will have no effect on ignition timing.

All ignition timing functions are controlled by the powertrain control module (PCM). For additional information, refer to the appropriate Powertrain Diagnostics Procedures service manual for operation of the DRB Scan Tool.

DIAGNOSIS AND TESTING (Continued)

MAP SENSOR

For an operational description, diagnosis or removal/ installation procedures, refer to Group 14, Fuel Systems.

CRANKSHAFT POSITION SENSOR

To perform a complete test of this sensor and its circuitry, refer to the DRB scan tool. Also refer to the appropriate Powertrain Diagnostics Procedures manual.

CAMSHAFT POSITION SENSOR

The camshaft position sensor is located in the distributor (Fig. 13) on all engines.

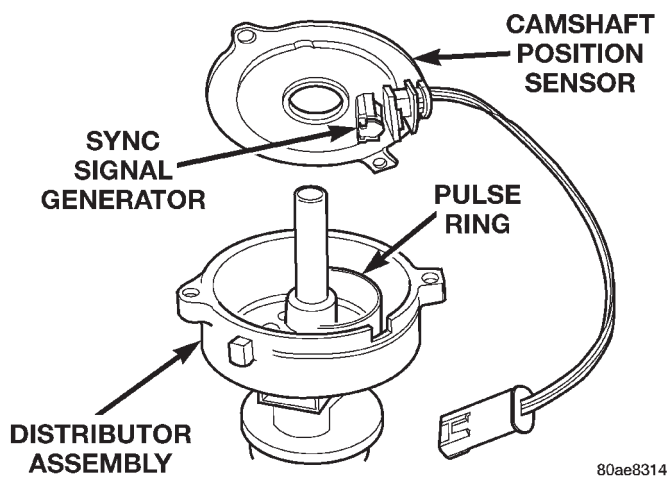


Fig. 13 Camshaft Position Sensor—Typical (5.2L/5.9L Distributor Shown)

To perform a complete test of this sensor and its circuitry, refer to the appropriate Powertrain Diagnostics Procedures service manual. To test the sensor only, refer to the following:

For this test, an analog (non-digital) voltmeter is needed. Do not remove the distributor connector from the distributor. Using small paper clips, insert them into the backside of the distributor wire harness connector to make contact with the terminals. Be sure that the connector is not damaged when inserting the paper clips. Attach voltmeter leads to these paper clips.

(1) Connect the positive (+) voltmeter lead into the sensor output wire. This is at done the distributor wire harness connector. For wire identification, refer to Group 8W, Wiring Diagrams.

(2) Connect the negative (-) voltmeter lead into the ground wire. For wire identification, refer to Group 8W, Wiring Diagrams.

(3) Set the voltmeter to the 15 Volt DC scale.

(4) **5.2L/5.9L Engines:** Remove distributor cap from distributor (two screws). Rotate (crank) the engine until the distributor rotor is pointed towards

the rear of vehicle. The movable pulse ring should now be within the sensor pickup.

(5) **4.0L Engine:** Remove distributor cap from distributor (two screws). Rotate (crank) the engine until the distributor rotor is pointed to approximately the 11 o'clock position. The movable pulse ring should now be within the sensor pickup.

(6) Turn ignition key to ON position. Voltmeter should read approximately 5.0 volts.

(7) If voltage is not present, check the voltmeter leads for a good connection.

(8) If voltage is still not present, check for voltage at the supply wire. For wire identification, refer to Group 8W, Wiring Diagrams.

(9) If 5 volts is not present at supply wire, check for voltage at PCM 32-way connector (cavity A-17). Refer to Group 8W, Wiring for location of connector/terminal. Leave the PCM connector connected for this test.

(10) If voltage is still not present, perform vehicle test using the DRB scan tool.

(11) If voltage is present at cavity A-17, but not at the supply wire:

(a) Check continuity between the supply wire. This is checked between the distributor connector and cavity A-17 at the PCM. If continuity is not present, repair the harness as necessary.

(b) Check for continuity between the camshaft position sensor output wire and cavity A-18 at the PCM. If continuity is not present, repair the harness as necessary.

(c) Check for continuity between the ground circuit wire at the distributor connector and ground. If continuity is not present, repair the harness as necessary.

(12) While observing the voltmeter, crank the engine with ignition switch. The voltmeter needle should fluctuate between 0 and 5 volts while the engine is cranking. This verifies that the camshaft position sensor in the distributor is operating properly and a sync pulse signal is being generated.

If sync pulse signal is not present, replacement of the camshaft position sensor is necessary

ENGINE COOLANT TEMPERATURE SENSOR

For an operational description, diagnosis and removal/installation procedures, refer to Group 14, Fuel System.

INTAKE MANIFOLD AIR TEMPERATURE SENSOR

For an operational description, diagnosis and removal/installation procedures, refer to Group 14, Fuel System.

DIAGNOSIS AND TESTING (Continued)

SPARK PLUG CABLES

Check the spark plug cable connections for good contact at the coil(s), distributor cap towers, and spark plugs. Terminals should be fully seated. The insulators should be in good condition and should fit tightly on the coil, distributor and spark plugs. Spark plug cables with insulators that are cracked or torn must be replaced.

Clean high voltage ignition cables with a cloth moistened with a non-flammable solvent. Wipe the cables dry. Check for brittle or cracked insulation.

On 5.2L/5.9L V-8 engines, spark plug cable heat shields are pressed into the cylinder head to surround each spark plug cable boot and spark plug (Fig. 14). These shields protect the spark plug boots from damage (due to intense engine heat generated by the exhaust manifolds) and should not be removed. After the spark plug cable has been installed, the lip of the cable boot should have a small air gap to the top of the heat shield (Fig. 14).

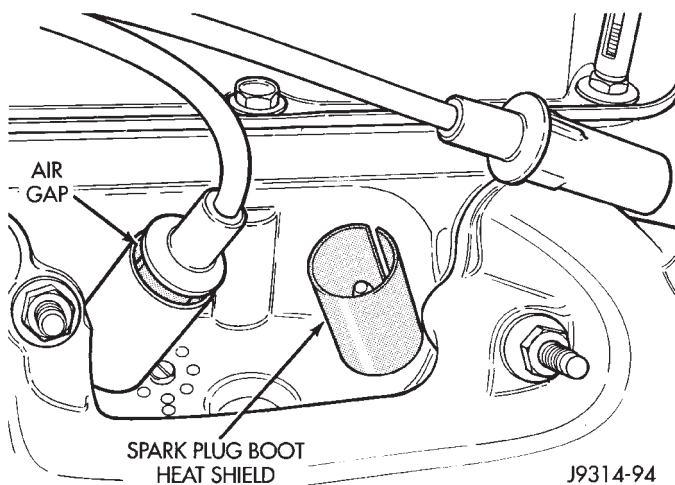


Fig. 14 Heat Shields—5.2L/5.9L V-8 Engines

TESTING

When testing secondary cables for damage with an oscilloscope, follow the instructions of the equipment manufacturer.

If an oscilloscope is not available, spark plug cables may be tested as follows:

CAUTION: Do not leave any one spark plug cable disconnected for longer than necessary during testing. This may cause possible heat damage to the catalytic converter. Total test time must not exceed ten minutes.

With the engine running, remove spark plug cable from spark plug (one at a time) and hold next to a good engine ground. If the cable and spark plug are in good condition, the engine rpm should drop and the engine will run poorly. If engine rpm does not drop, the cable and/or spark plug may not be operat-

ing properly and should be replaced. Also check engine cylinder compression.

With the engine not running, connect one end of a test probe to a good ground. Start the engine and run the other end of the test probe along the entire length of all spark plug cables. If cables are cracked or punctured, there will be a noticeable spark jump from the damaged area to the test probe. The cable running from the ignition coil to the distributor cap can be checked in the same manner. Cracked, damaged or faulty cables should be replaced with resistance type cable. This can be identified by the words ELECTRONIC SUPPRESSION printed on the cable jacket.

Use an ohmmeter to test for open circuits, excessive resistance or loose terminals. If equipped, remove the distributor cap from the distributor. **Do not remove cables from cap.** Remove cable from spark plug. Connect ohmmeter to spark plug terminal end of cable and to corresponding electrode in distributor cap. Resistance should be 250 to 1000 Ohms per inch of cable. If not, remove cable from distributor cap tower and connect ohmmeter to the terminal ends of cable. If resistance is not within specifications as found in the SPARK PLUG CABLE RESISTANCE chart, replace the cable. Test all spark plug cables in this manner.

SPARK PLUG CABLE RESISTANCE

MINIMUM	MAXIMUM
250 Ohms Per Inch	1000 Ohms Per Inch
3000 Ohms Per Foot	12,000 Ohms Per Foot

To test ignition coil-to-distributor cap cable, do not remove the cable from the cap. Connect ohmmeter to rotor button (center contact) of distributor cap and terminal at ignition coil end of cable. If resistance is not within specifications as found in the Spark Plug Cable Resistance chart, remove the cable from the distributor cap. Connect the ohmmeter to the terminal ends of the cable. If resistance is not within specifications as found in the Spark Plug Cable Resistance chart, replace the cable. Inspect the ignition coil tower for cracks, burns or corrosion.

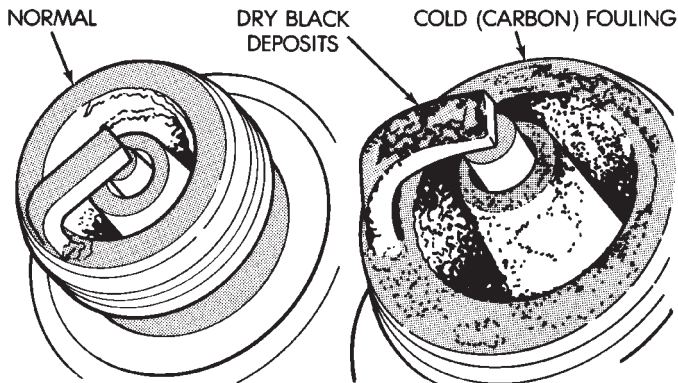
SPARK PLUG CONDITIONS

NORMAL OPERATING

The few deposits present on the spark plug will probably be light tan or slightly gray in color. This is evident with most grades of commercial gasoline (Fig. 15). There will not be evidence of electrode burning. Gap growth will not average more than approximately 0.025 mm (.001 in) per 1600 km (1000

DIAGNOSIS AND TESTING (Continued)

miles) of operation. Spark plugs that have normal wear can usually be cleaned, have the electrodes filed, have the gap set and then be installed.



J908D-15

Fig. 15 Normal Operation and Cold (Carbon) Fouling

Some fuel refiners in several areas of the United States have introduced a manganese additive (MMT) for unleaded fuel. During combustion, fuel with MMT causes the entire tip of the spark plug to be coated with a rust colored deposit. This rust color can be misdiagnosed as being caused by coolant in the combustion chamber. Spark plug performance is not affected by MMT deposits.

COLD FOULING/CARBON FOULING

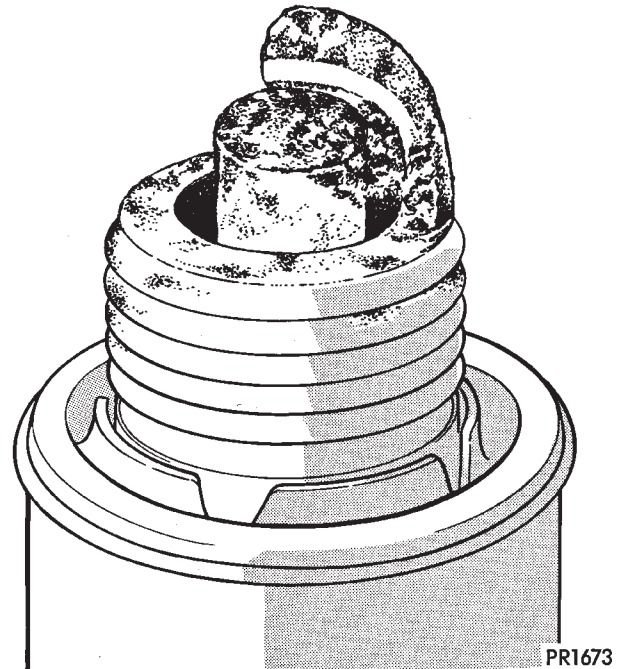
Cold fouling is sometimes referred to as carbon fouling. The deposits that cause cold fouling are basically carbon (Fig. 15). A dry, black deposit on one or two plugs in a set may be caused by sticking valves or defective spark plug cables. Cold (carbon) fouling of the entire set of spark plugs may be caused by a clogged air cleaner element or repeated short operating times (short trips).

WET FOULING OR GAS FOULING

A spark plug coated with excessive wet fuel or oil is wet fouled. In older engines, worn piston rings, leaking valve guide seals or excessive cylinder wear can cause wet fouling. In new or recently overhauled engines, wet fouling may occur before break-in (normal oil control) is achieved. This condition can usually be resolved by cleaning and reinstalling the fouled plugs.

OIL OR ASH ENCRUSTED

If one or more spark plugs are oil or oil ash encrusted (Fig. 16), evaluate engine condition for the cause of oil entry into that particular combustion chamber.

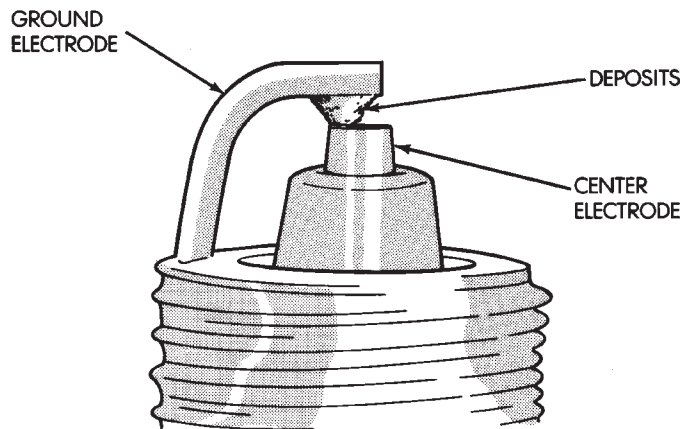


PR1673

Fig. 16 Oil or Ash Encrusted

ELECTRODE GAP BRIDGING

Electrode gap bridging may be traced to loose deposits in the combustion chamber. These deposits accumulate on the spark plugs during continuous stop-and-go driving. When the engine is suddenly subjected to a high torque load, deposits partially liquefy and bridge the gap between electrodes (Fig. 17). This short circuits the electrodes. Spark plugs with electrode gap bridging can be cleaned using standard procedures.



J908D-11

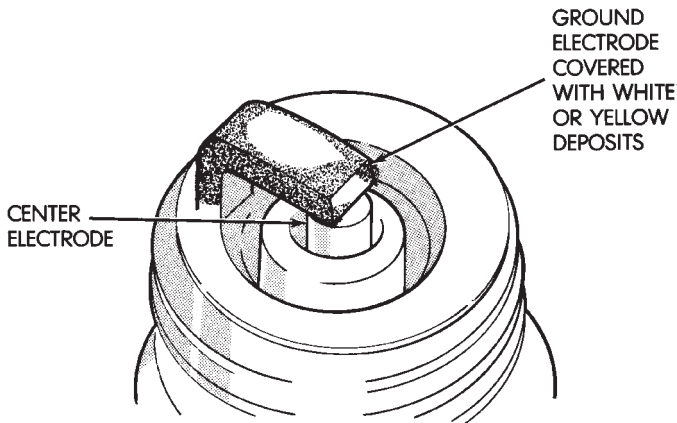
Fig. 17 Electrode Gap Bridging

SCAVENGER DEPOSITS

Fuel scavenger deposits may be either white or yellow (Fig. 18). They may appear to be harmful, but this is a normal condition caused by chemical additives in certain fuels. These additives are designed to

DIAGNOSIS AND TESTING (Continued)

change the chemical nature of deposits and decrease spark plug misfire tendencies. Notice that accumulation on the ground electrode and shell area may be heavy, but the deposits are easily removed. Spark plugs with scavenger deposits can be considered normal in condition and can be cleaned using standard procedures.

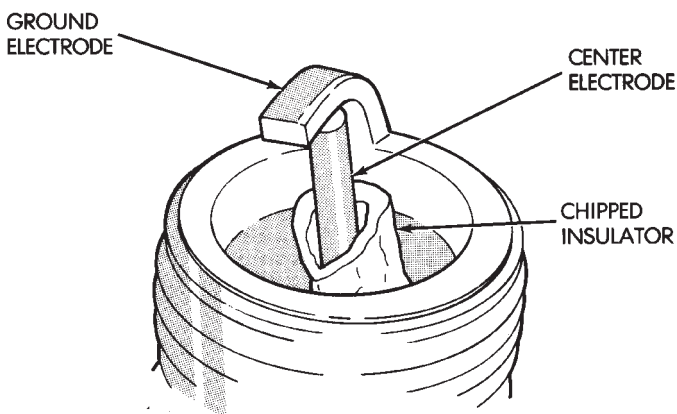


J908D-12

Fig. 18 Scavenger Deposits

CHIPPED ELECTRODE INSULATOR

A chipped electrode insulator usually results from bending the center electrode while adjusting the spark plug electrode gap. Under certain conditions, severe detonation can also separate the insulator from the center electrode (Fig. 19). Spark plugs with this condition must be replaced.



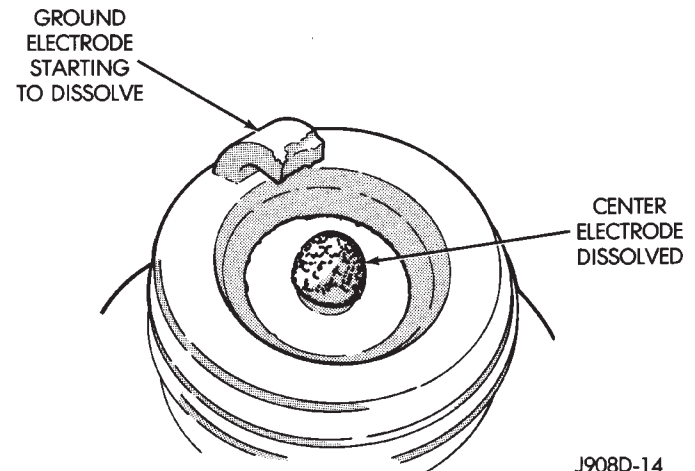
J908D-13

Fig. 19 Chipped Electrode Insulator

PREIGNITION DAMAGE

Preignition damage is usually caused by excessive combustion chamber temperature. The center electrode dissolves first and the ground electrode dissolves somewhat later (Fig. 20). Insulators appear relatively deposit free. Determine if the spark plug has the correct heat range rating for the engine.

Determine if ignition timing is over advanced or if other operating conditions are causing engine overheating. (The heat range rating refers to the operating temperature of a particular type spark plug. Spark plugs are designed to operate within specific temperature ranges. This depends upon the thickness and length of the center electrodes porcelain insulator.)

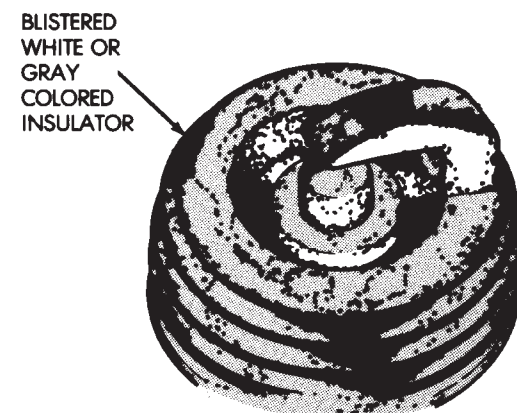


J908D-14

Fig. 20 Preignition Damage

SPARK PLUG OVERHEATING

Overheating is indicated by a white or gray center electrode insulator that also appears blistered (Fig. 21). The increase in electrode gap will be considerably in excess of 0.001 inch per 1000 miles of operation. This suggests that a plug with a cooler heat range rating should be used. Over advanced ignition timing, detonation and cooling system malfunctions can also cause spark plug overheating.



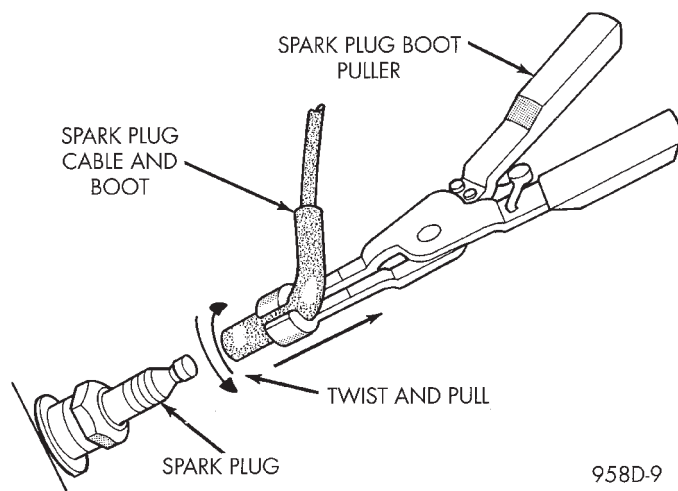
J908D-16

Fig. 21 Spark Plug Overheating

REMOVAL AND INSTALLATION

SPARK PLUG CABLES

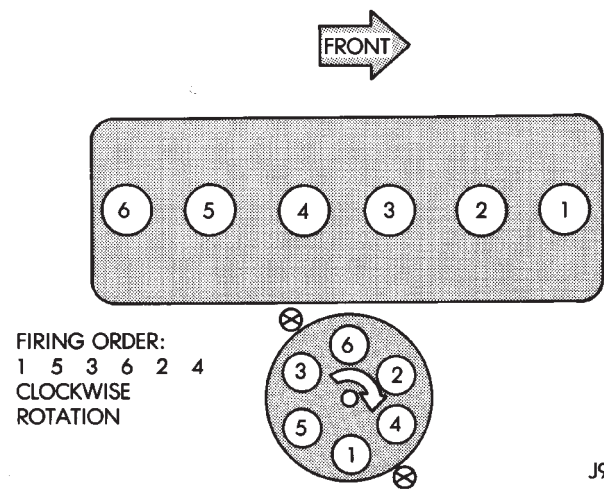
CAUTION: When disconnecting a high voltage cable from a spark plug or from the distributor cap, twist the rubber boot slightly (1/2 turn) to break it loose (Fig. 22). Grasp the boot (not the cable) and pull it off with a steady, even force.



958D-9

Fig. 22 Cable Removal

Install cables into the proper engine cylinder firing order (Fig. 23) or (Fig. 24).



J908D-7

Fig. 23 Engine Firing Order—4.0L 6-Cyl. Engine

When replacing the spark plug and coil cables, route the cables correctly and secure in the proper retainers. Failure to route the cables properly can cause the radio to reproduce ignition noise. It could also cause cross ignition of the plugs or short circuit the cables to ground.

When installing new cables, make sure a positive connection is made. A snap should be felt when a

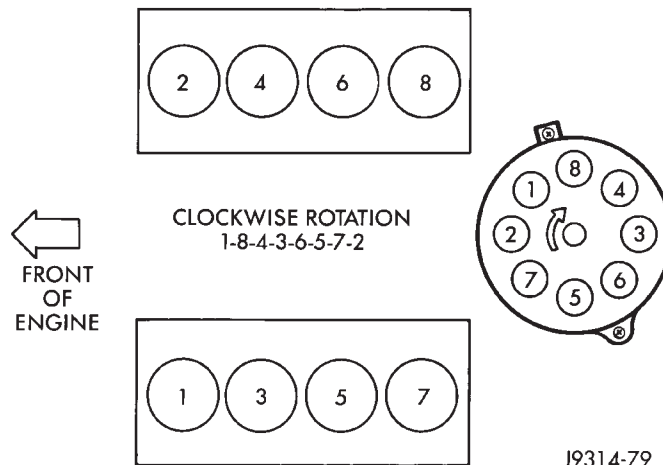
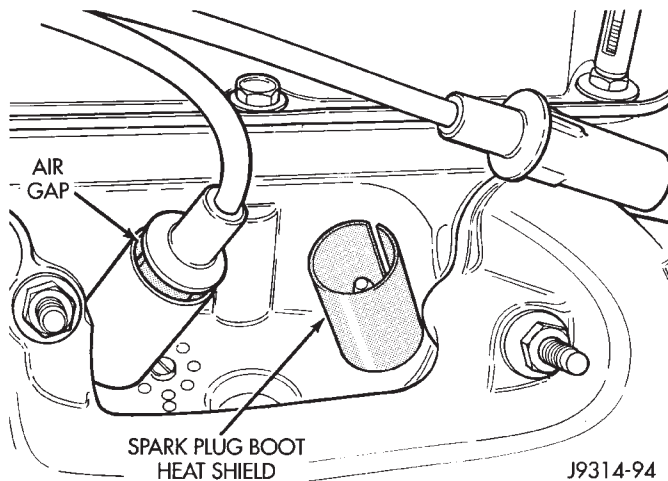


Fig. 24 Engine Firing Order—5.2L/5.9L V-8 Engines

good connection is made between the plug cable and the distributor cap tower.

SPARK PLUGS

On 5.2L/5.9L V-8 engines, spark plug cable heat shields are pressed into the cylinder head to surround each cable boot and spark plug (Fig. 25).



J9314-94

Fig. 25 Heat Shields—5.2L/5.9L Engines

If removal of the heat shield(s) is necessary, remove the spark plug cable and compress the sides of shield for removal. Each shield is slotted to allow for compression and removal. To install the shields, align shield to machined opening in cylinder head and tap into place with a block of wood.

PLUG REMOVAL

(1) Always remove spark plug or ignition coil cables by grasping at the cable boot (Fig. 22). Turn the cable boot 1/2 turn and pull straight back in a steady motion. Never pull directly on the cable. Internal damage to cable will result.

REMOVAL AND INSTALLATION (Continued)

(2) Prior to removing the spark plug, spray compressed air around the spark plug hole and the area around the spark plug. This will help prevent foreign material from entering the combustion chamber.

(3) Remove the spark plug using a quality socket with a rubber or foam insert.

(4) Inspect the spark plug condition. Refer to Spark Plug Condition in the Diagnostics and Testing section of this group.

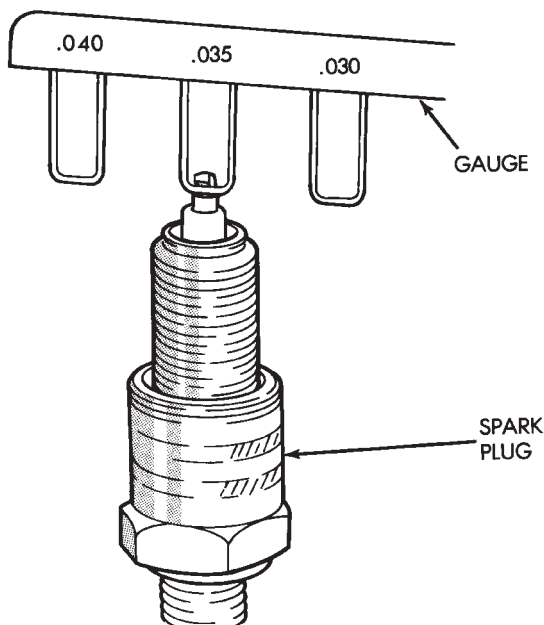
PLUG CLEANING

The plugs may be cleaned using commercially available spark plug cleaning equipment. After cleaning, file the center electrode flat with a small point file or jewelers file before adjusting gap.

CAUTION: Never use a motorized wire wheel brush to clean the spark plugs. Metallic deposits will remain on the spark plug insulator and will cause plug misfire.

PLUG GAP ADJUSTMENT

Check the spark plug gap with a gap gauge tool. If the gap is not correct, adjust it by bending the ground electrode (Fig. 26). **Never attempt to adjust the gap by bending the center electrode.**



J908D-10

Fig. 26 Setting Spark Plug Gap—Typical

SPARK PLUG GAP

4.0L 6-Cyl. Engine: .89 mm (.035 in).

5.2/5.9L V-8 Engines: 1.01 mm (.040 in).

PLUG INSTALLATION

Special care should be taken when installing spark plugs into the cylinder head spark plug wells. Be sure the plugs do not drop into the plug wells as electrodes can be damaged.

Always tighten spark plugs to the specified torque. Over tightening can cause distortion resulting in a change in the spark plug gap or a cracked porcelain insulator.

When replacing the spark plug and ignition coil cables, route the cables correctly and secure them in the appropriate retainers. Failure to route the cables properly can cause the radio to reproduce ignition noise. It could cause cross ignition of the spark plugs or short circuit the cables to ground.

(1) Start the spark plug into the cylinder head by hand to avoid cross threading.

(2) Tighten spark plugs to 35-41 N·m (26-30 ft. lbs.) torque.

(3) Install spark plug cables over spark plugs.

IGNITION COIL—5.2L/5.9L ENGINES

The ignition coil is an epoxy filled type. If the coil is replaced, it must be replaced with the same type.

REMOVAL

The coil is mounted to a bracket that is bolted to the front of the right engine cylinder head (Fig. 27). This bracket is mounted on top of the automatic belt tensioner bracket using common bolts.

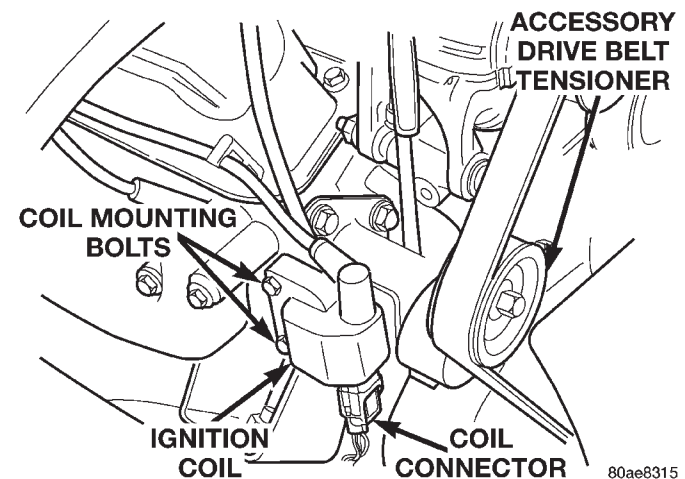


Fig. 27 Ignition Coil—5.2L/5.9L V-8 Engines

(1) Disconnect the primary wiring from the ignition coil.

(2) Disconnect the secondary spark plug cable from the ignition coil.

REMOVAL AND INSTALLATION (Continued)

WARNING: DO NOT REMOVE THE COIL MOUNTING BRACKET-TO-CYLINDER HEAD MOUNTING BOLTS. THE COIL MOUNTING BRACKET IS UNDER ACCESSORY DRIVE BELT TENSION. IF THIS BRACKET IS TO BE REMOVED FOR ANY REASON, ALL BELT TENSION MUST FIRST BE RELIEVED. REFER TO THE BELT SECTION OF GROUP 7, COOLING SYSTEM.

(3) Remove ignition coil from coil mounting bracket (two bolts).

INSTALLATION

(1) Install the ignition coil to coil bracket. If nuts and bolts are used to secure coil to coil bracket, tighten to 11 N·m (100 in. lbs.) torque. If the coil mounting bracket has been tapped for coil mounting bolts, tighten bolts to 5 N·m (50 in. lbs.) torque.

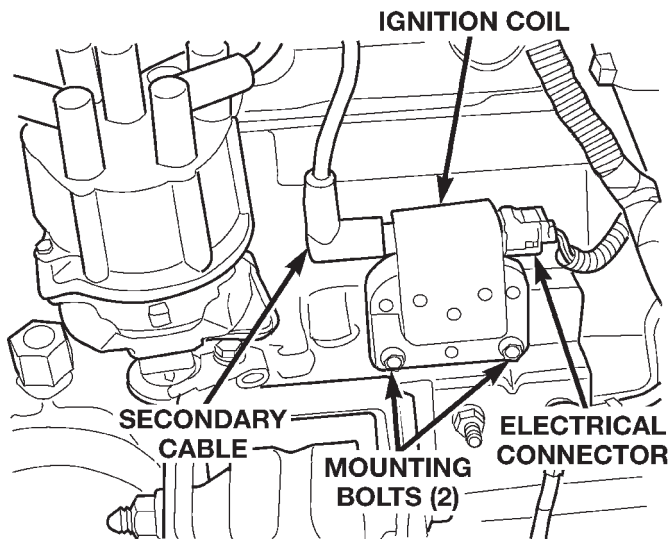
(2) Connect all wiring to ignition coil.

IGNITION COIL—4.0L ENGINE

The ignition coil is an epoxy filled type. If the coil is replaced, it must be replaced with the same type.

REMOVAL

The ignition coil is mounted to a bracket on the side of the engine to the front of the distributor (Fig. 28).



80ae8319

Fig. 28 Ignition Coil—4.0L Engine

(1) Disconnect the ignition coil secondary cable from ignition coil (Fig. 28).

(2) Disconnect engine harness connector from ignition coil.

(3) Remove ignition coil mounting bolts (nuts may also be used on back side of bracket).

(4) Remove coil.

INSTALLATION

(1) Install ignition coil to bracket. If nut and bolts are used to secure coil to coil bracket, tighten to 11 N·m (100 in. lbs.) torque. If bolts are used, tighten bolts to 5 N·m (50 in. lbs.) torque.

(2) Connect engine harness connector to coil.

(3) Connect ignition coil cable to ignition coil.

AUTOMATIC SHUTDOWN (ASD) RELAY

The Automatic Shutdown (ASD) relay is located in the Power Distribution Center (PDC). The PDC is located in the engine compartment (Fig. 29). Refer to label on PDC cover for relay location.

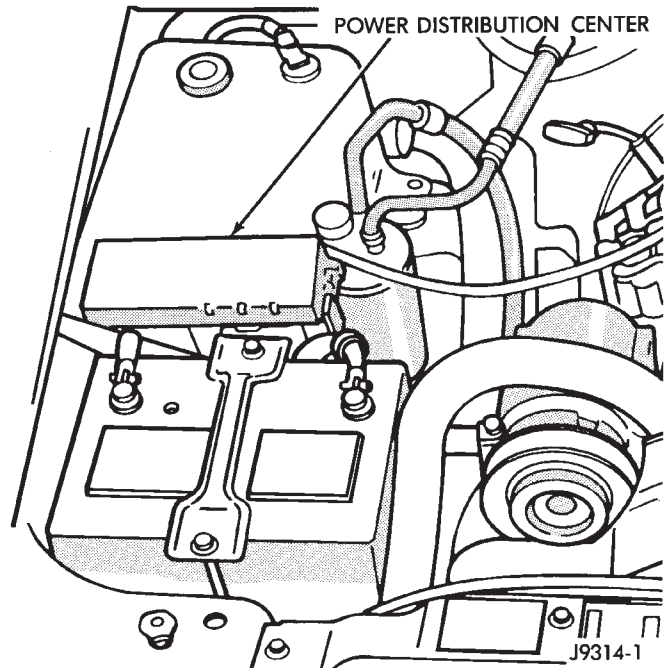


Fig. 29 Power Distribution Center

REMOVAL

- (1) Remove PDC cover.
- (2) Remove relay by lifting straight up.

INSTALLATION

(1) Check condition of relay terminals at PDC for corrosion or damage. Also check the heights of relay terminal pins at PDC. Pin height should be same for all pins. Repair as necessary before installing relay.

(2) Push relay into connector.

(3) Install relay cover.

REMOVAL AND INSTALLATION (Continued)

CRANKSHAFT POSITION SENSOR—5.2L/5.9L ENGINES

REMOVAL

The sensor is bolted to the top of the cylinder block near the rear of right cylinder head (Fig. 30).

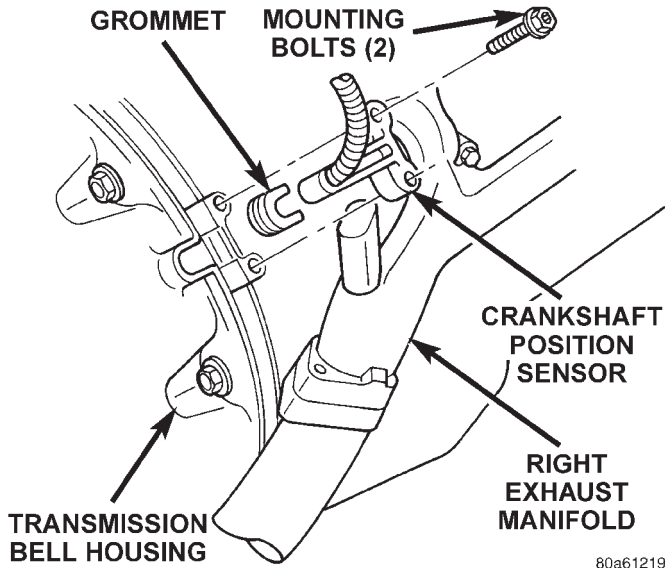


Fig. 30 Crankshaft Position Sensor—5.2L/5.9L Engines

- (1) Disconnect crankshaft position sensor pigtail harness (3-way connector) from main wiring harness.
- (2) Remove two sensor (recessed hex head) mounting bolts (Fig. 30).
- (3) Remove sensor from engine.

INSTALLATION

- (1) Position crankshaft position sensor to engine.
- (2) Install mounting bolts and tighten to 8 N-m (70 in. lbs.) torque.
- (3) Connect main harness electrical connector to sensor.

CRANKSHAFT POSITION SENSOR—4.0L ENGINE

The crankshaft position sensor is mounted to the transmission bellhousing at the left/rear side of the engine block (Fig. 31). The sensor is **adjustable** and is attached with one bolt. A wire shield/router is attached to the sensor (Fig. 31).

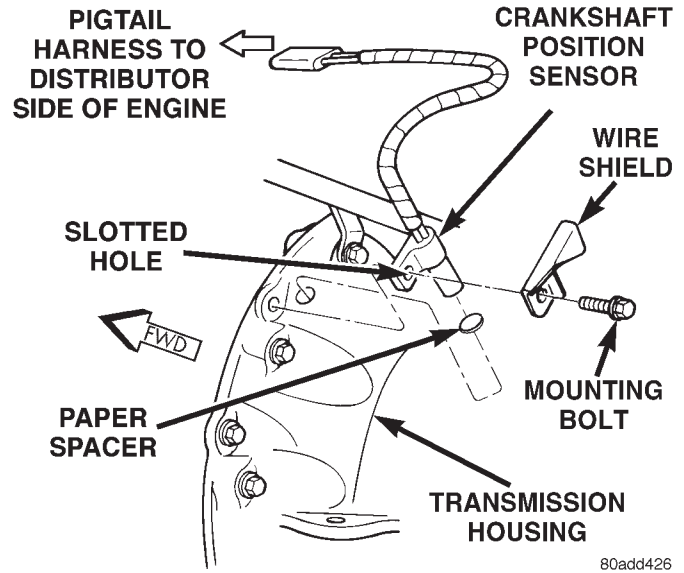


Fig. 31 Crankshaft Position Sensor—4.0L 6-Cylinder Engine

REMOVAL

- (1) Disconnect sensor pigtail harness (3-way connector) from main engine wiring harness. This connection is made near rear of distributor.
- (2) Remove sensor mounting bolt.
- (3) Remove wire shield and sensor.

INSTALLATION

4.0L engines with automatic transmission:

New replacement sensors will be equipped with a paper spacer glued to bottom of sensor. If installing (returning) a **used** sensor to vehicle, a new paper spacer must be installed to bottom of sensor. This spacer will be ground off the first time engine is started. If spacer is not used, sensor will be broken the first time engine is started.

- (1) New Sensors: Be sure paper spacer is installed to bottom of sensor. If not, obtain spacer PN05252229.
- (2) Used Sensors: Clean bottom of sensor and install spacer PN05252229.
- (3) Install sensor into transmission bellhousing hole.
- (4) Position sensor wire shield to sensor (Fig. 31).
- (5) Push sensor against flywheel/drive plate. With sensor pushed against flywheel/drive plate, tighten mounting bolt to 7 N-m (60 in. lbs.) torque.

REMOVAL AND INSTALLATION (Continued)

- (6) Route sensor wiring harness into wire shield.
- (7) Connect sensor pigtail harness electrical connector to main wiring harness.

CAMSHAFT POSITION SENSOR

The camshaft position sensor is located in the distributor on all 4.0L 6-cylinder and 5.2L/5.9L V-8 engines (Fig. 32).

REMOVAL

Distributor removal is not necessary to remove camshaft position sensor.

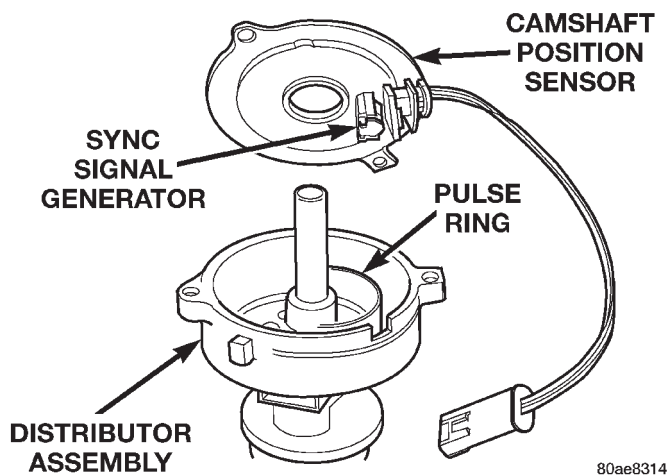


Fig. 32 Camshaft Position Sensor—Typical (5.2L/5.9L Shown)

- (1) 5.2L/5.9L Engines: Remove air cleaner tube at throttle body.
- (2) Disconnect negative cable from battery.
- (3) Remove distributor cap from distributor (two screws).
- (4) Disconnect camshaft position sensor wiring harness from main engine wiring harness.
- (5) Remove distributor rotor from distributor shaft.
- (6) Lift the camshaft position sensor assembly from the distributor housing (Fig. 32).

INSTALLATION

- (1) Install camshaft position sensor to distributor. Align sensor into notch on distributor housing.
- (2) Connect wiring harness.
- (3) Install rotor.
- (4) Install distributor cap. Tighten mounting screws.
- (5) 5.2L/5.9L Engines: Install air cleaner tube to throttle body.

MANIFOLD ABSOLUTE PRESSURE (MAP) SENSOR

For removal and installation, refer to Manifold Absolute Pressure Sensor in group 14, Fuel Systems.

ENGINE COOLANT TEMPERATURE SENSOR

For an operational description, diagnosis and removal/installation procedures, refer to Group 14, Fuel System.

THROTTLE POSITION SENSOR

For an operational description, diagnosis and removal/installation procedures, refer to Group 14, Fuel System.

INTAKE MANIFOLD AIR TEMPERATURE SENSOR

For an operational description, diagnosis and removal/installation procedures, refer to Group 14, Fuel System.

DISTRIBUTOR—5.2L/5.9L ENGINES**REMOVAL**

CAUTION: Base ignition timing is not adjustable on any 5.2L/5.9L V-8 engine. Distributors do not have built in centrifugal or vacuum assisted advance. Base ignition timing and timing advance are controlled by the Powertrain Control Module (PCM). Because a conventional timing light can not be used to adjust distributor position after installation, note position of distributor before removal.

- (1) Disconnect negative cable from battery.
- (2) Remove air cleaner tube at throttle body.
- (3) Disconnect coil secondary cable at distributor cap.
- (4) Disconnect all secondary spark plug cables at distributor cap. Note and mark position before removal.
- (5) Remove distributor cap from distributor (two screws).
- (6) Mark position of distributor housing in relationship to engine or dash panel. This is done to aid in installation.
- (7) Before distributor is removed, number one cylinder must be brought to Top Dead Center (TDC) firing position.
- (8) Attach a socket to Crankshaft Vibration Damper mounting bolt.
- (9) Slowly rotate engine clockwise, as viewed from front, until indicating mark on crankshaft vibration damper is aligned to 0 degree (TDC) mark on timing chain cover (Fig. 33).
- (10) The distributor rotor should now be aligned to CYL. NO. 1 alignment mark (stamped) into camshaft position sensor (Fig. 34). If not, rotate crankshaft through another complete 360 degree turn. Note position of number one cylinder spark plug cable (on the cap) in relation to rotor. Rotor should now be aligned to this position.

REMOVAL AND INSTALLATION (Continued)

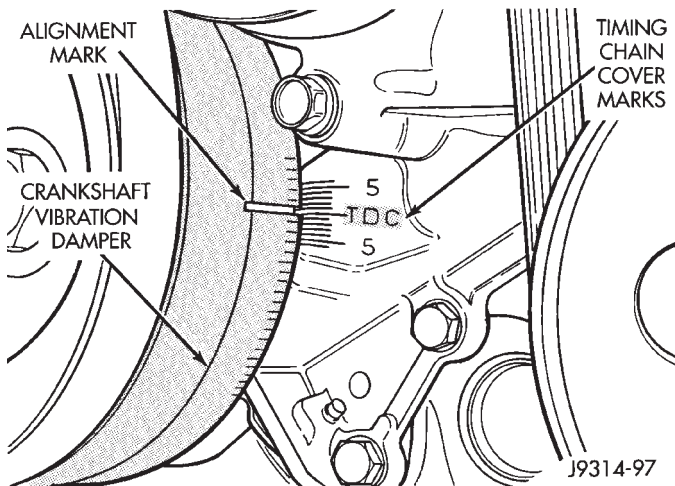


Fig. 33 Damper-To-Cover Alignment Marks—Typical

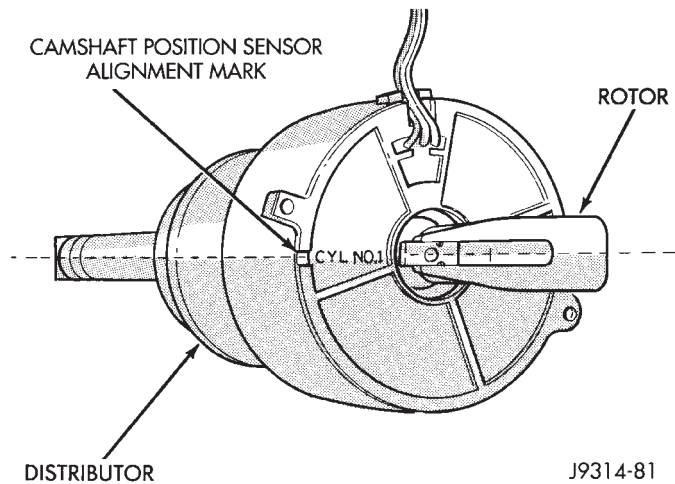


Fig. 34 Rotor Alignment Mark—5.2L/5.9L Engines

(11) Disconnect camshaft position sensor wiring harness 3-way connector from main engine wiring harness.

(12) Remove distributor rotor from distributor shaft.

(13) Remove distributor holddown clamp bolt and clamp (Fig. 35).

(14) Remove distributor from vehicle.

CAUTION: Do not crank engine with distributor removed. Distributor/crankshaft relationship will be lost.

INSTALLATION

If engine has been cranked while distributor is removed, establish relationship between distributor shaft and number one piston position as follows:

Rotate crankshaft in a clockwise direction, as viewed from front, until number one cylinder piston is at top of compression stroke (compression should be felt on finger with number one spark plug

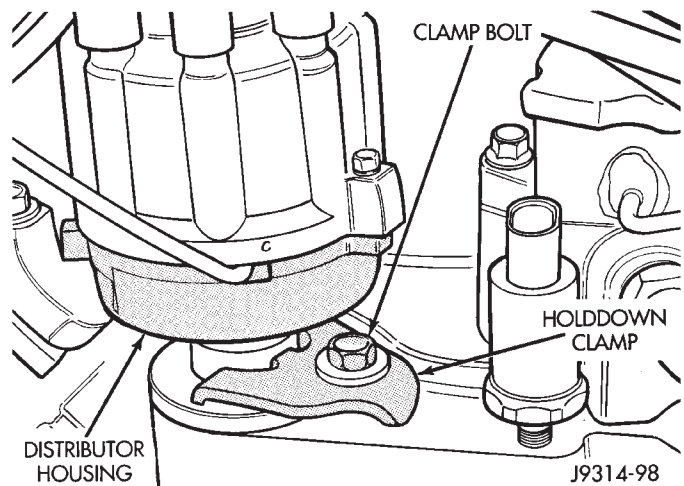


Fig. 35 Distributor Holddown Clamp—5.2L/5.9L Engines

removed). Then continue to slowly rotate engine clockwise until indicating mark (Fig. 33) is aligned to 0 degree (TDC) mark on timing chain cover.

(1) Clean top of cylinder block for a good seal between distributor base and block.

(2) Lightly oil the rubber o-ring seal on distributor housing.

(3) Install rotor to distributor shaft.

(4) Position distributor into engine to its original position. Engage tongue of distributor shaft with slot in distributor oil pump drive gear. Position rotor to number one spark plug cable position.

(5) Install distributor holddown clamp and clamp bolt. Do not tighten bolt at this time.

(6) Rotate distributor housing until rotor is aligned to CYL. NO. 1 alignment mark on camshaft position sensor (Fig. 34).

(7) Tighten clamp holddown bolt (Fig. 35) to 22.5 N·m (200 in. lbs.) torque.

(8) Connect camshaft position sensor wiring harness to main engine harness.

(9) Install distributor cap. Tighten mounting screws.

(10) Install secondary cables to distributor cap.

(11) Refer to following, Checking Distributor Position.

CHECKING DISTRIBUTOR POSITION

To verify correct distributor rotational position, the DRB scan tool must be used.

WARNING: WHEN PERFORMING THE FOLLOWING TEST, THE ENGINE WILL BE RUNNING. BE CAREFUL NOT TO STAND IN LINE WITH THE FAN BLADES OR FAN BELT. DO NOT WEAR LOOSE CLOTHING.

REMOVAL AND INSTALLATION (Continued)

(1) Connect DRB scan tool to data link connector. The data link connector is located in passenger compartment, below and to left of steering column.

(2) Gain access to SET SYNC screen on DRB.

(3) Follow directions on DRB screen and start engine. Bring to operating temperature (engine must be in "closed loop" mode).

(4) With engine running at **idle speed**, the words **IN RANGE** should appear on screen along with 0°. This indicates correct distributor position.

(5) If a plus (+) or a minus (-) is displayed next to degree number, and/or the degree displayed is not zero, loosen but do not remove distributor holddown clamp bolt. Rotate distributor until **IN RANGE** appears on screen. Continue to rotate distributor until achieving as close to 0° as possible. After adjustment, tighten clamp bolt to 22.5 N·m (200 in. lbs.) torque.

The degree scale on SET SYNC screen of DRB is referring to fuel synchronization only. **It is not referring to ignition timing.** Because of this, do not attempt to adjust ignition timing using this method. Rotating distributor will have no effect on ignition timing. All ignition timing values are controlled by powertrain control module (PCM).

(6) After testing, install air cleaner tube to throttle body.

DISTRIBUTOR—4.0L ENGINE

All 4.0L distributors contain an internal oil seal that prevents oil from entering the distributor housing. The seal is not serviceable.

Factory replacement distributors are equipped with a plastic alignment pin already installed. The pin is located in an access hole on the bottom of the distributor housing (Fig. 36). It is used to temporarily lock the rotor to the cylinder number 1 position during installation. The pin must be removed after installing the distributor.

The camshaft position sensor is located in the distributor on all 4.0L engines (Fig. 37). For removal/installation procedures, refer to Camshaft Position Sensor. Distributor removal is not necessary for sensor removal.

Refer to (Fig. 37) for an exploded view of distributor.

A fork with a slot is supplied on bottom of distributor housing where the housing base seats against engine block (Fig. 37). The centerline of the slot aligns with distributor holddown bolt hole in engine block. Because of the fork, the distributor cannot be rotated. Distributor rotation is not necessary as all ignition timing requirements are handled by the powertrain control module (PCM).

The position of distributor determines fuel synchronization only. It does not determine ignition timing.

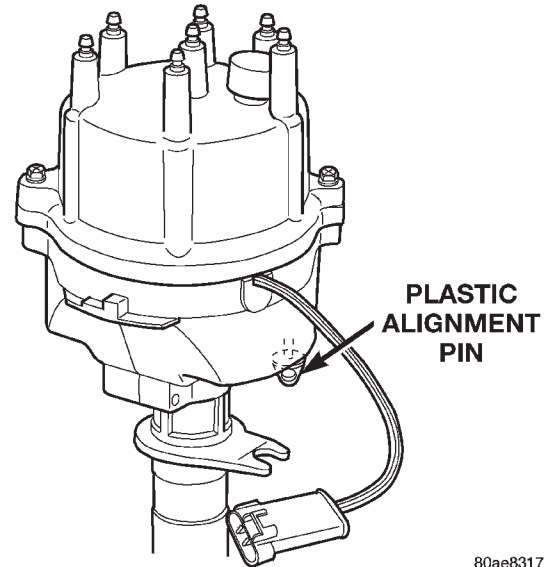


Fig. 36 Plastic Alignment Pin—4.0L Engine

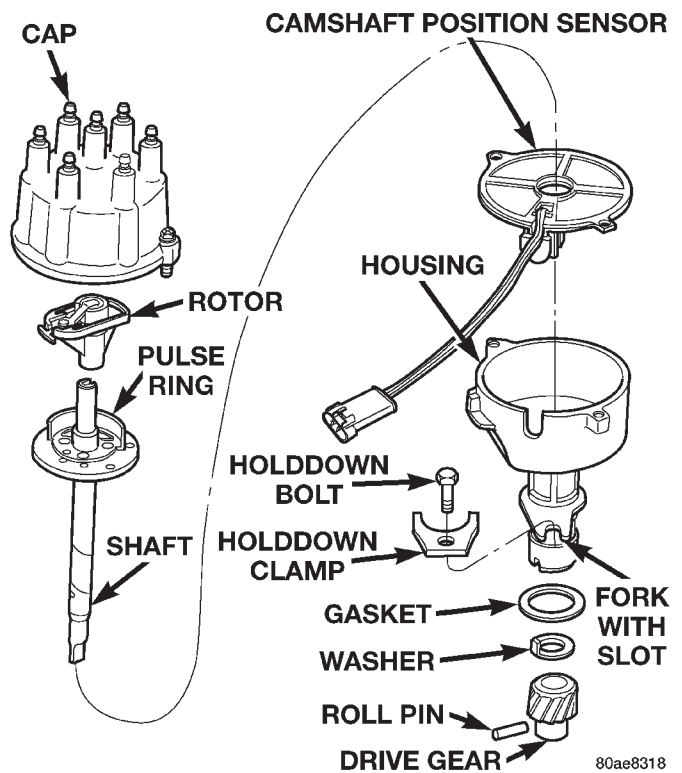


Fig. 37 Distributor—4.0L Engine—Typical

NOTE: Do not attempt to modify this fork to attain ignition timing.

REMOVAL—4.0L ENGINE

- (1) Disconnect negative battery cable at battery.
- (2) Disconnect coil secondary cable at coil.
- (3) Remove distributor cap from distributor (2 screws). Do not remove cables from cap. Do not remove rotor.

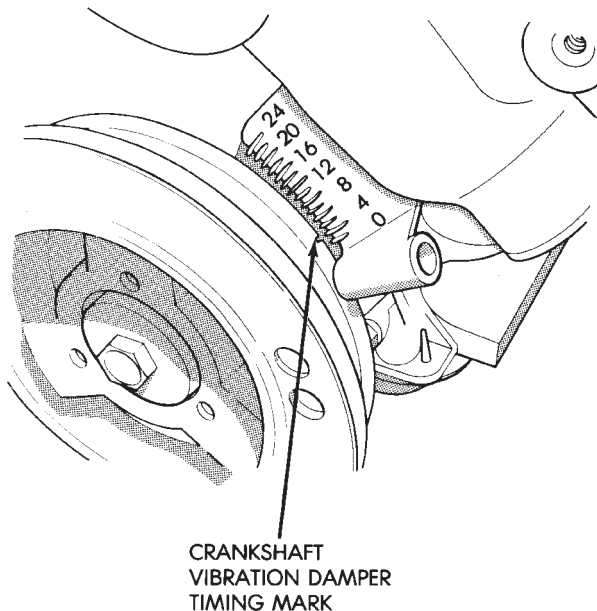
REMOVAL AND INSTALLATION (Continued)

(4) Disconnect distributor wiring harness 3-way connector from main engine harness.

(5) Remove cylinder number 1 spark plug.

(6) Hold a finger over the open spark plug hole. Rotate engine at vibration dampener bolt until compression (pressure) is felt.

(7) Slowly continue to rotate engine. Do this until timing index mark on vibration damper pulley aligns with top dead center (TDC) mark (0 degree) on timing degree scale (Fig. 38). Always rotate engine in direction of normal rotation. Do not rotate engine backward to align timing marks.



J898D-14

Fig. 38 Align Timing Marks—4.0L Engine

(8) Remove distributor holddown bolt and clamp.

(9) Remove distributor from engine by slowly lifting straight up.

(10) Note that rotor will rotate slightly in a counterclockwise direction while lifting up the distributor. The oil pump gear will also rotate slightly in a counterclockwise direction while lifting up the distributor. This is due to the helical cut gears on distributor and camshaft.

(11) Note removed position of rotor during distributor removal. During installation, this will be referred to as the Pre-position.

(12) Observe slot in oil pump gear through hole on side of engine. It should be slightly before (counterclockwise of) the 11 o'clock position (Fig. 39).

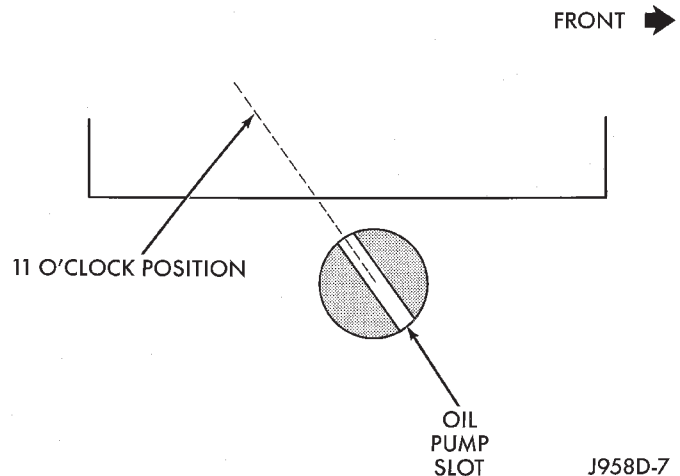


Fig. 39 Slot At 11 O'clock Position—4.0L Engine

(13) Remove and discard old distributor-to-engine block gasket.

INSTALLATION

(1) If engine crankshaft has been rotated after distributor removal, cylinder number 1 must be returned to its proper firing stroke. Refer to previous REMOVAL Step 5 and Step 6. These steps must be done before installing distributor.

(2) Check position of slot on oil pump gear. It should be just slightly before (counterclockwise of) the 11 o'clock position (Fig. 39). If not, place a flat blade screwdriver into oil pump gear and rotate it into proper position.

(3) Factory replacement distributors are equipped with a plastic alignment pin already installed (Fig. 36). This pin is used to temporarily hold rotor to cylinder number 1 firing position during distributor installation. If pin is in place, proceed to Step 8. If not, proceed to next step.

(4) If original distributor is to be reinstalled, such as during engine overhaul, the plastic pin will not be available. A 3/16 inch drift pin punch tool may be substituted for plastic pin.

(5) Remove camshaft position sensor from distributor housing. Lift straight up.

REMOVAL AND INSTALLATION (Continued)

(6) Four different alignment holes are provided on the plastic ring (Fig. 40). **Note that 2.5L and 4.0L engines have different alignment holes (Fig. 40).**

(7) Rotate distributor shaft and install pin punch tool through proper alignment hole in plastic ring (Fig. 40) and into mating access hole in distributor housing. This will prevent distributor shaft and rotor from rotating.

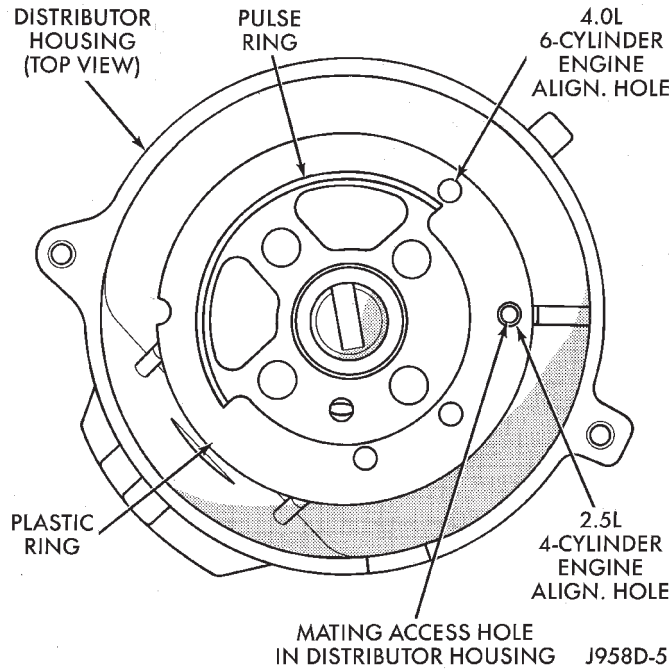


Fig. 40 Pin Alignment Holes—4.0L Engine

(8) Clean distributor mounting hole area of engine block.

(9) Install new distributor-to-engine block gasket (Fig. 37).

(10) Install rotor to distributor shaft.

Pre-position distributor into engine while holding centerline of base slot in 1 o'clock position (Fig. 41). Continue to engage distributor into engine. The rotor and distributor will rotate clockwise during installation. This is due to the helical cut gears on distributor and camshaft. When distributor is fully seated to engine block, the centerline of base slot should be aligned to clamp bolt mounting hole on engine (Fig. 42). The rotor should also be pointed at 5 o'clock position.

It may be necessary to rotate rotor and distributor shaft (very slightly) to engage distributor shaft with slot in oil pump gear. The same may have to be done to engage distributor gear with camshaft gear.

The distributor is correctly installed when:

- rotor is pointed at 5 o'clock position.
- plastic alignment pin (or pin punch tool) is still installed to distributor.
- number 1 cylinder piston is set at top dead center (TDC) (compression stroke).

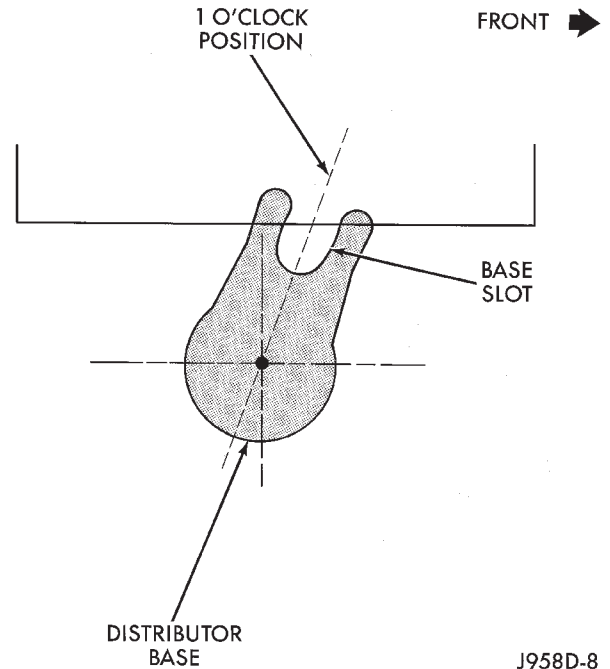


Fig. 41 Distributor Pre-position—4.0L Engines

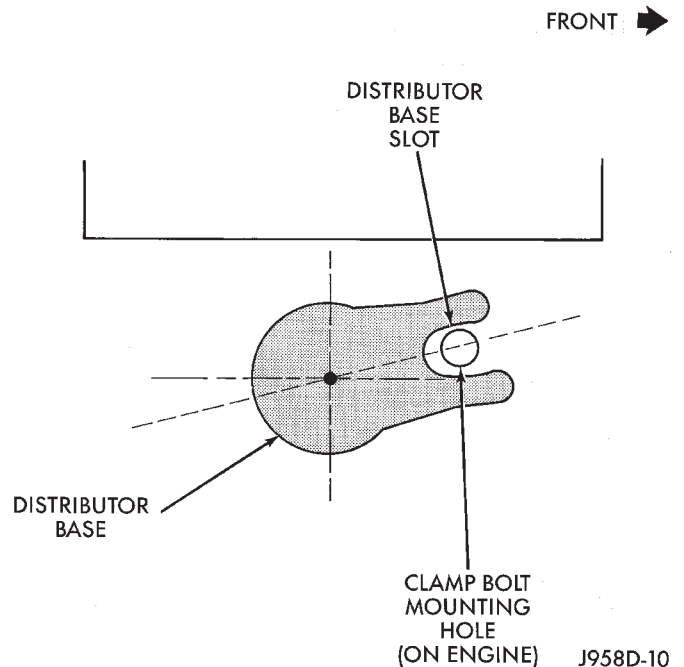


Fig. 42 Distributor Engaged Position—4.0L Engine

• centerline of the slot at base of distributor is aligned to centerline of distributor holddown bolt hole on engine. In this position, the holddown bolt should easily pass through slot and into engine.

No adjustments are necessary. Proceed to next step.

(11) Install distributor holddown clamp and bolt. Tighten bolt to 23 N·m (17 ft. lbs.) torque.

(12) Remove pin punch tool from distributor. Or, if plastic alignment pin was used, remove it straight down from bottom of distributor. Discard plastic pin.

REMOVAL AND INSTALLATION (Continued)

(13) If removed, install camshaft position sensor to distributor. Align wiring harness grommet to notch in distributor housing.

(14) Install rotor.

CAUTION: If distributor cap is incorrectly positioned on distributor housing, the cap or rotor may be damaged when engine is started.

(15) Install distributor cap. Tighten distributor cap holddown screws to 3 N·m (26 in. lbs.) torque.

(16) If removed, install spark plug cables to distributor cap. For proper firing order, refer to Specifications section at end of this group. See Engine Firing Order.

(17) Connect distributor wiring harness to main engine harness.

(18) Connect battery cable to battery.

POWERTRAIN CONTROL MODULE (PCM)

Refer to Group 14, Fuel System for procedures.

IGNITION SWITCH AND KEY CYLINDER

The ignition key must be in the key cylinder for cylinder removal.

KEY CYLINDER REMOVAL

- (1) Disconnect negative cable from battery.
- (2) If equipped with tilt column, remove tilt lever by turning it counterclockwise.
- (3) Remove upper and lower covers (shrouds) from steering column (Fig. 43).

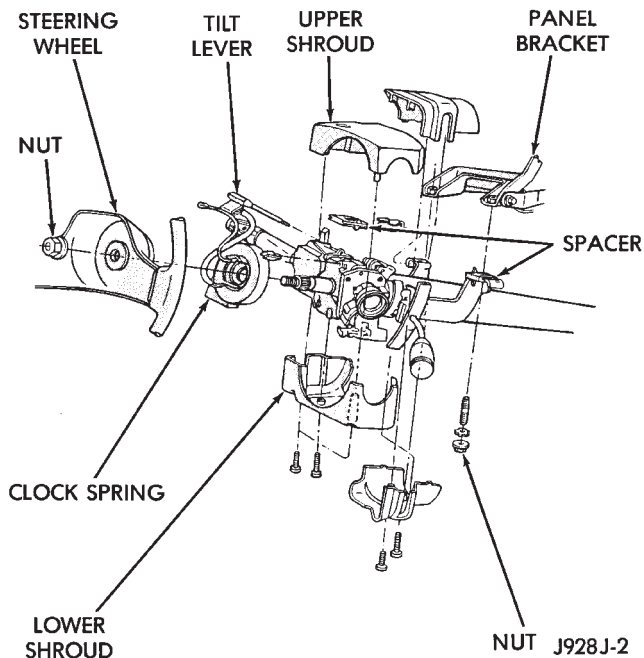


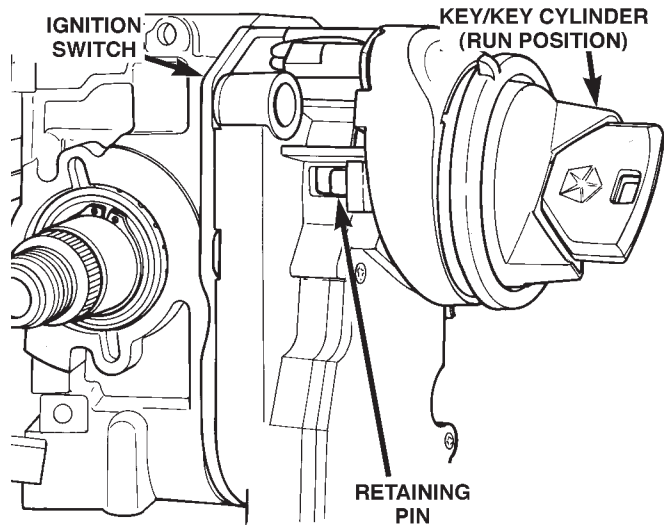
Fig. 43 Shroud Removal/Installation—Typical

(4) If equipped with automatic transmission, place shifter in PARK position.

(5) A retaining pin (Fig. 44) is located at side of key cylinder assembly.

(a) Rotate key to RUN position.

(b) Press in on retaining pin while pulling key cylinder from ignition switch.



80a592b6

Fig. 44 Retaining Pin

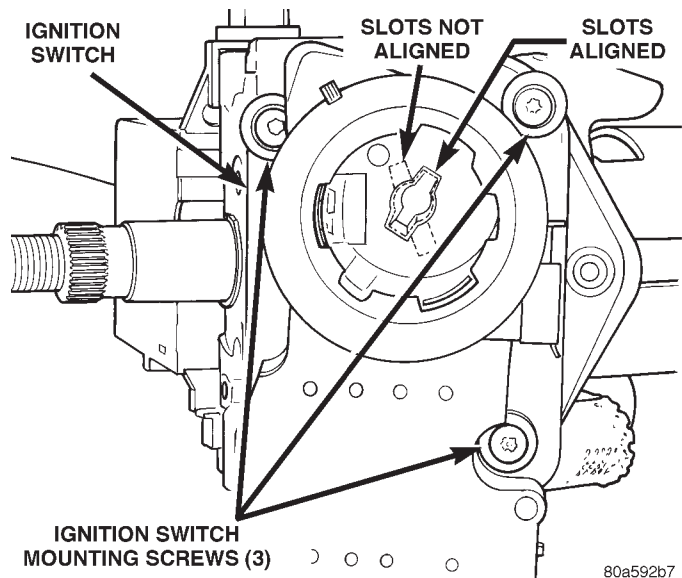
IGNITION SWITCH REMOVAL

(1) Remove key lock cylinder. Refer to previous steps.

(2) Remove 3 ignition switch mounting screws (Fig. 45). Use tamper proof torx bit (Snap-On® SDMTR10 or equivalent) to remove screws.

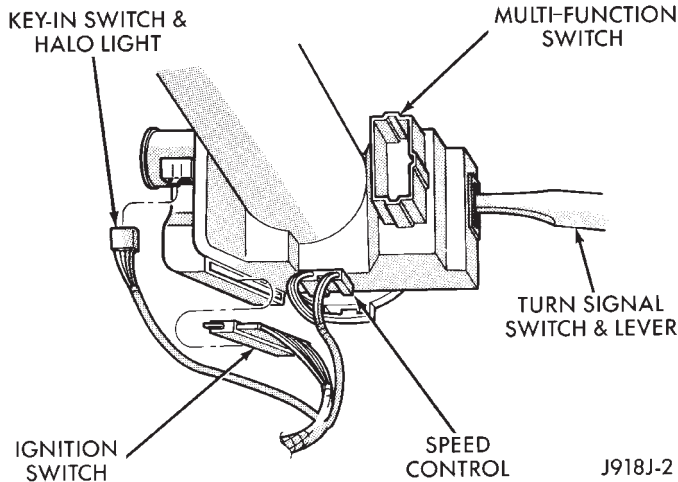
(3) Gently pull switch away from column. Release connector locks on 7-terminal wiring connector at ignition switch and remove connector (Fig. 46).

(4) Release connector lock on 4-terminal halo lamp wiring connector and remove connector (Fig. 46).



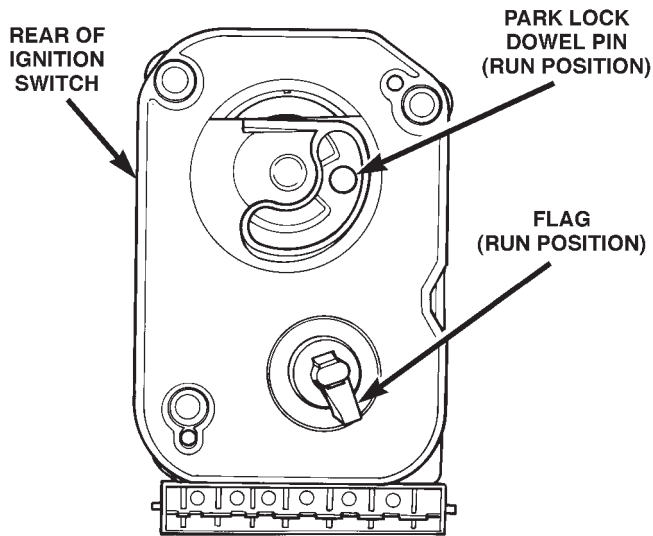
80a592b7

Fig. 45 Switch Mounting Screws

REMOVAL AND INSTALLATION (Continued)**Fig. 46 Ignition Switch and Halo Lamp Connectors****IGNITION SWITCH AND KEY CYLINDER INSTALLATION**

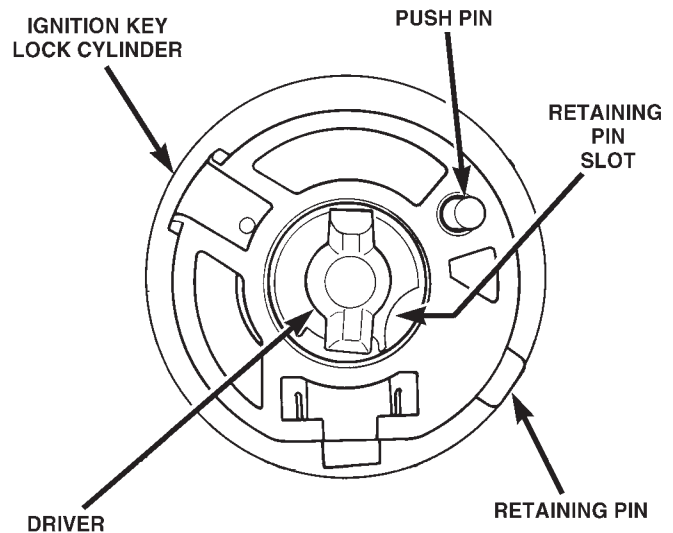
If installing **ignition key lock cylinder only**, proceed to following steps 2, 3 and 4. Also refer to following steps 12 through 18. If installing both switch and key cylinder, refer to steps 1 through 18.

(1) Rotate flag (Fig. 47) on rear of ignition switch until in RUN position. This step must be done to allow tang (Fig. 48) on key cylinder to fit into slots (Fig. 45) within ignition switch.

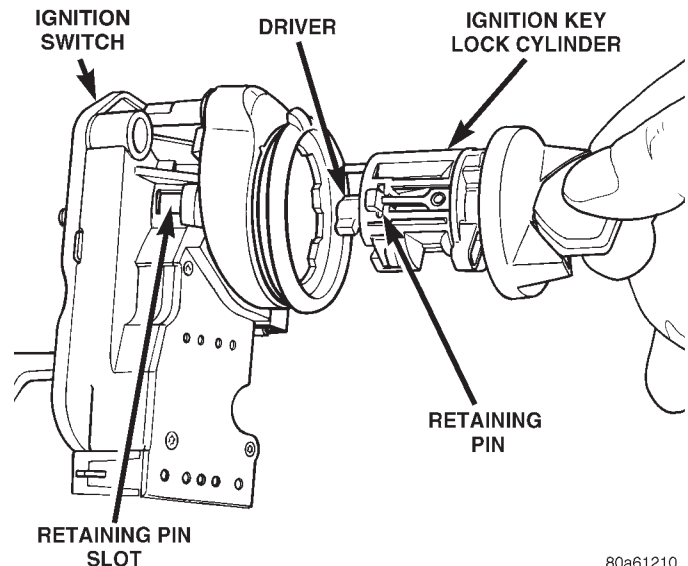
**Fig. 47 Flag in RUN Position**

(2) With key into ignition key cylinder, rotate key clockwise until retaining pin can be depressed (Fig. 48) or (Fig. 49).

(3) Install key cylinder into ignition switch by aligning retaining pin into retaining pin slot (Fig. 49). Push key cylinder into switch until retaining pin engages. After pin engages, rotate key to OFF or LOCK position.

**Fig. 48 Key Cylinder—Rear View**

80a592b9

**Fig. 49 Installing Key Cylinder Into Switch**

80a61210

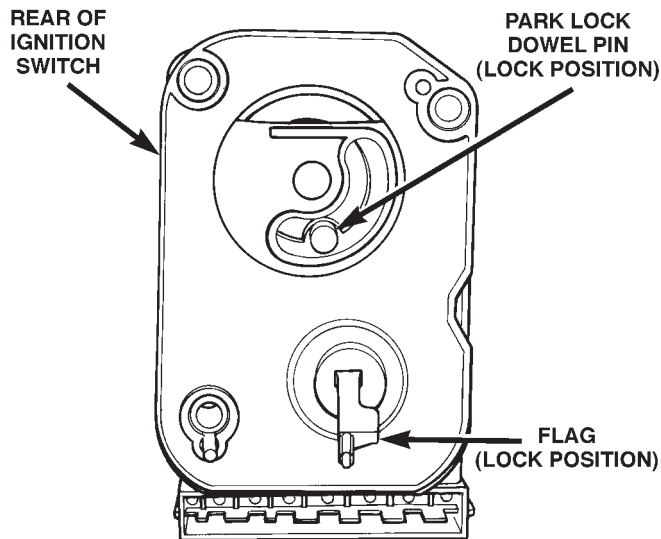
(4) Check for proper retention of key cylinder by attempting to pull cylinder from switch.

(5) Automatic Transmission Only: Before attaching ignition switch to steering column, the transmission shifter must be in PARK position. The park lock dowel pin on rear of ignition switch (Fig. 50) must also be properly indexed into the park lock linkage (Fig. 51) before installing switch.

(6) The flag at rear of ignition switch (Fig. 50) must be properly indexed into steering column before installing switch. This flag is used to operate the steering wheel lock lever in steering column (Fig. 52). This lever allows steering wheel position to be locked when key switch is in LOCK position.

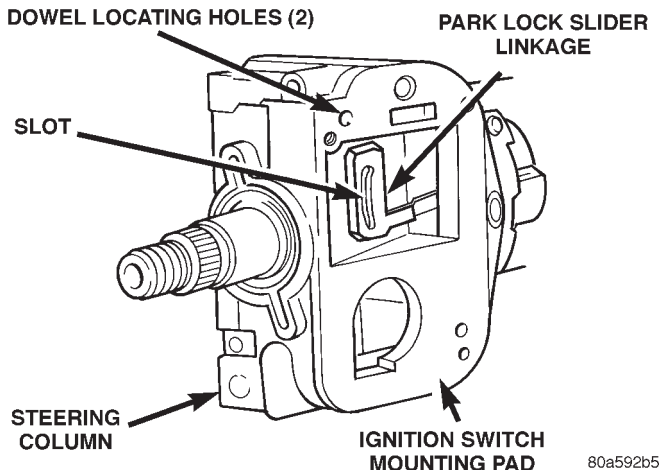
(7) Place ignition switch in LOCK position. The switch is in the LOCK position when column lock flag is parallel to ignition switch terminals (Fig. 50).

REMOVAL AND INSTALLATION (Continued)



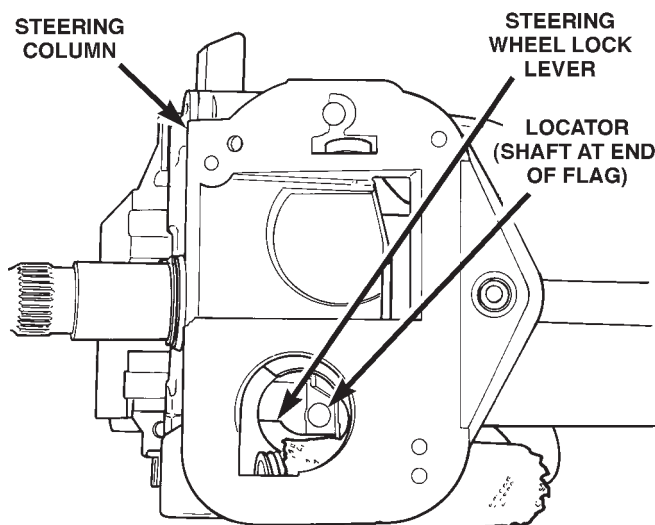
80a61211

Fig. 50 Ignition Switch View From Column



80a592b5

Fig. 51 Park Lock Linkage—Automatic Transmission—Typical



80a61212

Fig. 52 Steering Wheel Lock Lever

(8) Automatic Transmission Only: Apply a light coating of grease to park lock dowel pin and park lock slider linkage. Before installing switch, push the park lock slider linkage (Fig. 51) forward until it bottoms. Do a final positioning by pulling it rearward about one-quarter inch.

(9) Apply a light coating of grease to both column lock flag and shaft at end of flag.

(10) Place ignition switch into openings on steering column.

(a) Automatic Transmission Only: Be sure park lock dowel pin on rear of ignition switch enters slot in park lock slider linkage (Fig. 51).

(b) Be sure flag on rear of switch is positioned above steering wheel lock lever (Fig. 52).

(c) Align dowel pins on rear of switch into holes on side of steering column.

(d) Install 3 ignition switch mounting screws. Tighten screws to $3 \text{ N}\cdot\text{m} \pm .5 \text{ N}\cdot\text{m}$ (26 in. lbs. ± 4 in. lbs.) torque.

(11) Connect electrical connectors to ignition switch and halo lamp. Make sure that switch locking tabs are fully seated in wiring connectors.

(12) Install steering column covers (shrouds). Tighten screws to $2 \text{ N}\cdot\text{m}$ (17 in. lbs.) torque.

(13) Install tilt column lever (if equipped).

(14) Connect negative cable to battery.

(15) Check for proper operation of halo light.

(16) Automatic Transmission Only: Shifter should lock in PARK position when key is in LOCK position (if equipped with shift lock device). Shifter should unlock when key rotated to ON position.

(17) Check for proper operation of ignition switch in ACCESSORY, LOCK, OFF, ON, RUN, and START positions.

(18) Steering wheel should lock when key is in LOCK position. Rotate steering wheel to verify. Steering wheel should unlock when key is rotated to ON position.

SHIFTER/IGNITION INTERLOCK

On models equipped with an automatic transmission, a cable connects the ignition switch with the floor shift lever. The shifter will be locked in the PARK position when the ignition key is in the LOCK or ACCESSORY positions. The cable can be adjusted or replaced. Refer to Group 21, Transmissions for procedures. The ignition interlock device within the steering column is not serviceable. If service is necessary, the steering column must be replaced. Refer to Group 19, Steering for procedures.

SPECIFICATIONS

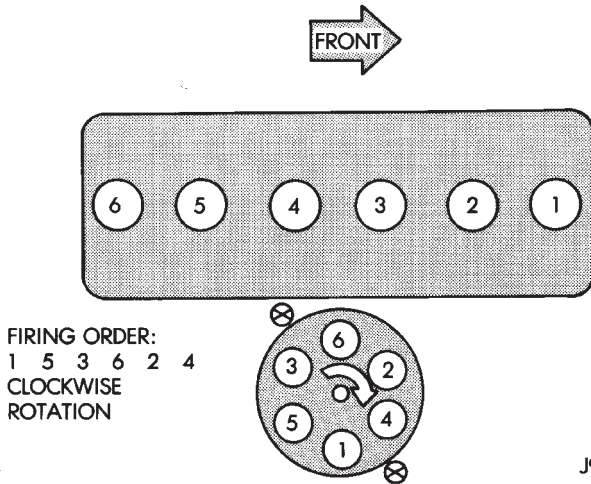
VECI LABEL

If anything differs between the specifications found on the Vehicle Emission Control Information (VECI) label and the following specifications, use specifications on VECI label. The VECI label is located in the engine compartment.

IGNITION TIMING

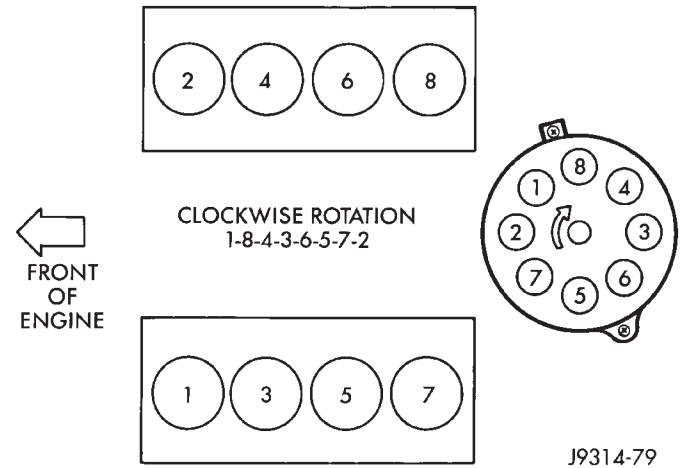
Ignition timing is not adjustable on any engine. Refer to Ignition Timing in the Diagnostics/Service Procedures section of this group for more information.

ENGINE FIRING ORDER—4.0L 6-CYLINDER ENGINE



J908D-7

ENGINE FIRING ORDER—5.2L/5.9L V-8 ENGINES



SPECIFICATIONS (Continued)

TORQUE CHART

DESCRIPTION	TORQUE
Crankshaft Position Sensor— 4.0L Engine7 N·m (60 in. lbs.)
Crankshaft Position Sensor— 5.2L/5.9L Engine8 N·m (70 in. lbs.)
Distributor Hold Down Bolt— All Engines23 N·m (17 ft. lbs.)
Ignition Coil Mounting (if tapped bolts are used)5 N·m (50 in. lbs.)
Ignition Coil Mounting (if nuts/bolts are used)11 N·m (100 in. lbs.)
Powertrain Control Module (PCM) Mounting Screws1 N·m (9 in. lbs.)
Spark Plugs—All Engines41 N·m (30 ft. lbs.)

SPARK PLUGS

ENGINE	PLUG TYPE	ELECTRODE GAP
4.0L 6-CYL.	RC12LYC	0.89 mm (.035 in.)
5.2/5.9L V-8	RC12LC4	1.01 mm (.040 in.)

SPARK PLUG CABLE RESISTANCE

MINIMUM	MAXIMUM
250 Ohms Per Inch	1000 Ohms Per Inch
3000 Ohms Per Foot	12,000 Ohms Per Foot

IGNITION COIL RESISTANCE

COIL MANUFACTURER	PRIMARY RESISTANCE 21-27°C (70-80°F)	SECONDARY RESISTANCE 21-27°C (70-80°F)
Diamond	0.97 - 1.18 Ohms	11,300 - 15,300 Ohms
Toyodenso	0.95 - 1.20 Ohms	11,300 - 13,300 Ohms

INSTRUMENT PANEL SYSTEMS

CONTENTS

	page		page
GENERAL INFORMATION			
BODY CONTROL MODULE	4	GRAPHIC DISPLAY MODULE	16
GAUGE	3	HEADLAMP HIGH BEAM INDICATOR LAMP ..	16
GRAPHIC DISPLAY MODULE	3	INSTRUMENT CLUSTER	10
INDICATOR LAMP	4	LOW FUEL WARNING LAMP	17
INSTRUMENT CLUSTER	2	MALFUNCTION INDICATOR LAMP	18
INSTRUMENT PANEL	2	ODOMETER AND TRIP ODOMETER	11
INTRODUCTION	2	OIL PRESSURE GAUGE	11
JUNCTION BLOCK	4	POWER OUTLET	18
VEHICLE INFORMATION CENTER	3	SEAT BELT REMINDER LAMP	18
DESCRIPTION AND OPERATION			
AIRBAG INDICATOR LAMP	6	SPEEDOMETER	12
ANTI-LOCK BRAKE SYSTEM LAMP	7	TACHOMETER	12
BRAKE WARNING LAMP	7	TURN SIGNAL INDICATOR LAMP	18
CHECK GAUGES LAMP	7	VEHICLE INFORMATION CENTER	19
CIGAR LIGHTER RELAY	8	VOLTMETER	12
CIGAR LIGHTER	7	SERVICE PROCEDURES	
CLUSTER ILLUMINATION LAMP	8	VEHICLE INFORMATION CENTER	21
COOLANT TEMPERATURE GAUGE	5	REMOVAL AND INSTALLATION	
CRUISE-ON INDICATOR LAMP	8	BODY CONTROL MODULE	28
FUEL GAUGE	5	CIGAR LIGHTER	30
HEADLAMP HIGH BEAM INDICATOR LAMP ...	9	CLUSTER BEZEL	24
LOW FUEL WARNING LAMP	9	CLUSTER BULB	27
MALFUNCTION INDICATOR LAMP	9	CLUSTER COMPONENTS	25
ODOMETER AND TRIP ODOMETER	5	COWL TOP TRIM PANEL	33
OIL PRESSURE GAUGE	6	GLOVE BOX COMPONENTS	32
POWER OUTLET	9	GLOVE BOX LAMP AND SWITCH	29
SEAT BELT REMINDER LAMP	10	GLOVE BOX LATCH STRIKER	30
SPEEDOMETER	6	GLOVE BOX MODULE	29
TACHOMETER	6	GLOVE BOX	31
TURN SIGNAL INDICATOR LAMP	10	GRAPHIC DISPLAY MODULE AND VEHICLE	
VOLTMETER	6	INFORMATION CENTER	29
DIAGNOSIS AND TESTING			
AIRBAG INDICATOR LAMP	12	INBOARD SWITCH POD	28
ANTI-LOCK BRAKE SYSTEM LAMP	13	INSTRUMENT CLUSTER	25
BRAKE WARNING LAMP	13	INSTRUMENT PANEL ASSEMBLY	34
CHECK GAUGES LAMP	14	INSTRUMENT PANEL CENTER BEZEL	31
CIGAR LIGHTER RELAY	14	INSTRUMENT PANEL TOP PAD	33
CIGAR LIGHTER	14	JUNCTION BLOCK	34
CLUSTER ILLUMINATION LAMP	15	OUTBOARD SWITCH POD	27
COOLANT TEMPERATURE GAUGE	11	POWER OUTLET DOOR	31
CRUISE-ON INDICATOR LAMP	15	POWER OUTLET	31
FUEL GAUGE	11	STEERING COLUMN OPENING COVER AND	
		KNEE BLOCKER	24
		SWITCH POD BEZEL	24
		TRIP ODOMETER RESET KNOB	25

GENERAL INFORMATION

INTRODUCTION

This group is responsible for covering the vehicle instrument panel. However, because the instrument panel serves as the command center of the vehicle, it is a very complex unit. The instrument panel is designed to house the controls and monitors for standard and optional powertrains, climate control systems, audio systems, lighting systems, safety systems and many other comfort or convenience items. It is also designed so that all of the controls and monitors can be safely reached and viewed by the vehicle operator, while still allowing relative ease of access to these items for service.

Complete service information coverage for all of the systems and components housed in the instrument panel in this section of the service manual would not be practical. It would result in a great deal of duplication and make this group too large for the information to be easily accessed and used. Therefore, the information found in this group has been limited as follows:

- General Information - Covers non-electrical components and features of the instrument panel that are not related to other systems.
- Description and Operation - Covers gauges and their sending units, warning lamps and their switches, and instrument panel illumination lamps.
- Diagnosis and Testing - Covers gauges and their sending units, warning lamps and their switches, and instrument panel illumination lamps.
- Removal and Installation - Covers all components installed on or in the instrument panel that require removal for diagnosis or service of any other instrument panel components covered in this group.

For more information on components or systems not covered above, refer to the proper group in this manual. If you are uncertain as to the proper group, refer to the Component and System Index at the back of this manual. Refer to Group 8W - Wiring Diagrams for complete circuit descriptions and diagrams.

INSTRUMENT PANEL

Modular construction allows all of the gauges and controls to be serviced from the front of the instrument panel. In addition, most of the instrument electrical or heating and air conditioning components can be accessed without complete instrument panel removal. If necessary, the instrument panel can be rolled-down and removed from the vehicle as an assembly.

Removal of the switch pod bezels allows access to most of the switches and the heating and air conditioning controls. Removal of the instrument cluster

bezel allows access to the cluster assembly and the radio. Removal of the cluster assembly allows access to the individual gauges, the cluster illumination and indicator lamp bulbs, and much of the instrument panel wiring.

Removal of the steering column opening cover/knee blocker provides access to the steering column mounts, the Body Control Module (BCM), the gear-shift interlock mechanism, and additional instrument panel and steering column wiring. Removal of the glove box module and center bezel unit allows access to the Vehicle Information Center (VIC), the Graphic Display Module (GDM), the in-vehicle temperature sensor, additional instrument panel wiring, and many of the heating and air conditioning components.

Removal of the instrument panel cowl top trim panel allows access to the instrument panel speakers, the solar sensor, and the automatic headlamp light sensor/vehicle theft security system lamp. Removal of the instrument panel top pad allows access to the passenger side airbag module.

Instrument panel removal is required for service of most internal components of the heating and air conditioning housing.

INSTRUMENT CLUSTER

One basic instrument cluster option is offered on Grand Cherokee models. This cluster is an electromechanical unit that utilizes integrated circuitry and information carried on the Chrysler Collision Detection (CCD) data bus network for control of all gauges and many of the indicator lamps. This cluster also incorporates a vacuum fluorescent display tube for the digital odometer/trip odometer display functions. Some variations of the cluster exist due to optional equipment and regulatory requirements.

The cluster includes the following analog gauges:

- Coolant temperature gauge
- Fuel gauge
- Oil pressure gauge
- Speedometer
- Tachometer
- Voltmeter.

This cluster includes provisions for the following indicator lamps:

- Airbag indicator lamp
- Anti-lock brake system lamp
- Brake warning lamp
- Check gauges lamp
- Cruise-on indicator lamp
- Headlamp high beam indicator lamp
- Low fuel warning lamp
- Malfunction indicator (Check Engine) lamp
- Seat belt reminder lamp
- Turn signal indicator lamps.

GENERAL INFORMATION (Continued)

This instrument cluster features circuitry that has an actuator test mode, which can be entered using a DRB scan tool. The actuator test mode will test each of the CCD bus message-controlled functions of the cluster by lighting the appropriate indicator lamps and positioning the gauge needles at several predetermined locations on the gauge faces in a prescribed sequence. For more information on this test, refer to the proper Diagnostic Procedures manual.

The instrument cluster component parts for this model are available for service. The cluster lens, the hood and mask, the gauge sets, the cluster housing with electronic circuit board and the odometer reset knob are available for service. Also, the individual cluster lamp bulbs with bulb holders can be serviced.

GRAPHIC DISPLAY MODULE

A Graphic Display Module (GDM) is standard equipment on all four-wheel drive Grand Cherokee models, unless the vehicle is equipped with the optional Vehicle Information Center (VIC). The GDM is mounted in the lower center stack area of the instrument panel, above the ash receiver and below the heater and air conditioner controls. Two-wheel drive Grand Cherokee models have a storage bin installed in place of the GDM as standard equipment.

The GDM display consists of a back-lit screen with an outline of the vehicle. The two rear wheels of the vehicle outline are illuminated by a lamp when the transfer case is engaged in any two-wheel drive operating mode. The two front wheels are also illuminated when the transfer case is engaged in any four-wheel drive operating mode.

The GDM also has up to three indicator lamps, which indicate to the driver whether the four-wheel drive mode selected is Lo, Part-Time, or Full-Time. The number of operational indicator lamps may vary, depending upon the optional four-wheel drive transfer case in the vehicle. A switch on the transfer case is hard-wired to the GDM so as to illuminate the proper wheels and indicator lamps.

The GDM bulbs and the transfer case switch can be serviced. However, if any other part of the GDM is damaged or faulty, the entire GDM must be replaced. Refer to Group 21 - Transmission and Transfer Case for the transfer case switch service procedures.

VEHICLE INFORMATION CENTER

The Vehicle Information Center (VIC) is an available option on Grand Cherokee models. The VIC module replaces the standard equipment Graphic Display Module (GDM). The VIC is mounted in the lower center stack area of the instrument panel, above the ash receiver and below the heater and air conditioner controls.

The VIC consists of a multicolored vacuum fluorescent display screen with an outline of the vehicle. The VIC is able to display four functions in a choice of five languages. The display functions include:

- Current time (12 or 24 hour clock), day, and date
- Monitor specific vehicle operating systems and alert the driver of a malfunction in a monitored system
- Provide service reminders or the distance to the next service interval
- The current transfer case mode of operation (four-wheel drive models).

The VIC display language choices include:

- English
- French
- German
- Italian
- Spanish.

The VIC receives input from hard-wired sensors and over the Chrysler Collision Detection (CCD) data bus network. In response to these inputs the VIC offers a combination of graphic and message displays, and provides requests for audible chime alerts to the Body Control Module (BCM) on the CCD data bus network.

Refer to the owner's manual for more information on the VIC controls, operation, and setting procedures. For diagnosis of the VIC module or the CCD data bus, refer to the proper Diagnostic Procedures manual. The VIC module cannot be repaired. If damaged or faulty, the entire module must be replaced.

GAUGE

With the ignition switch in the On or Start positions, voltage is supplied to all gauges through the instrument cluster electronic circuit board. With the ignition switch in the Off position, voltage is not supplied to the gauges. The gauges do not accurately indicate any vehicle condition unless the ignition switch is in the On or Start positions.

All of the instrument cluster gauges, except the odometer, are air core magnetic units. Two fixed electromagnetic coils are located within the gauge. These coils are wrapped at right angles to each other around a movable permanent magnet. The movable magnet is suspended within the coils on one end of a shaft. The gauge needle is attached to the other end of the shaft.

One of the coils has a fixed current flowing through it to maintain a constant magnetic field strength. Current flow through the second coil changes, which causes changes in its magnetic field strength. The current flowing through the second coil is changed by the instrument cluster electronic circuitry in response to messages received on the Chrysler Collision Detection (CCD) data bus network.

GENERAL INFORMATION (Continued)

The gauge needle moves as the movable permanent magnet aligns itself to the changing magnetic fields created around it by the electromagnets. These gauges also feature a small fixed permanent magnet which will move all of the gauge needles back to the low end of their respective scales after the ignition switch is turned to the Off position.

INDICATOR LAMP

Indicator lamps are located in the instrument cluster, and in the Graphic Display Module (GDM) or the Vehicle Information Center (VIC). Those lamps within the instrument cluster are served by the cluster circuit board and wire harness connectors. Those lamps located in the GDM or VIC modules are served by the GDM or VIC circuit board and wire harness connectors.

Most of the indicator lamps in the instrument cluster and VIC module are controlled by the instrument cluster or VIC module electronic circuitry in response to messages received over the Chrysler Collision Detection (CCD) data bus network from the Body Control Module (BCM), Powertrain Control Module (PCM), and Airbag Control Module (ACM). Only the anti-lock brake system lamp, four-wheel drive indicator lamps, lamp outage warning lamp, low coolant level warning lamp, low washer fluid warning lamp, and turn signal indicator lamps are hard-wired.

BODY CONTROL MODULE

A Body Control Module (BCM) is used on this model to control and integrate many of the electronic functions and features included on the vehicle. The BCM contains a central processing unit and interfaces with other modules in the vehicle on the Chrysler Collision Detection (CCD) data bus network.

The CCD data bus network allows the sharing of sensor information. This helps to reduce wire harness complexity, reduce internal controller hardware, and reduce component sensor current loads. At the same time, this system provides increased reliability, enhanced diagnostics, and allows the addition of many new feature capabilities.

Some of the functions and features that the BCM supports or controls, include:

- Chimes
- Automatic headlamp control
- Headlamp delay
- Headlamps on with ignition off and driver door open warning
- Key in ignition with ignition off and driver door open warning
- Automatic funeral or parade mode
- Panel lamp dimming
- Vehicle Theft Security System (VTSS)
- Illuminated entry

- Heated rear window and heated outside mirror control
- Intermittent wipe control
- Monitoring and transmitting door, liftgate, and liftglass ajar data
- Monitoring and transmitting outside ambient temperature data
- Monitoring and transmitting air conditioning select switch data
- Courtesy lamp time-out
- Door lock inhibit
- Electronic odometer and trip odometer
- Brake warning lamp
- Check gauges lamp
- High beam indicator lamp
- Seatbelt reminder lamp and chime
- Speed sensitive intermittent wipe
- Fog lamp control
- Electromechanical instrument cluster
- BCM diagnostic support
- Vehicle Information Center (VIC) support
- Rolling door locks
- Horn chirp upon door lock with Remote Keyless Entry (RKE)(programmable)
- Low fuel warning chime (programmable)
- Headlights on with wipers (programmable - with automatic headlamps only)

The BCM is mounted under the driver side outboard end of the instrument panel, behind the instrument panel support armature and below the outboard switch pod. For diagnosis of the BCM or the CCD data bus, the use of a DRB scan tool and the proper Diagnostic Procedures manual are recommended. The BCM can only be serviced by an authorized electronic repair station. Refer to the latest Warranty Policies and Procedures manual for a current listing of authorized electronic repair stations.

JUNCTION BLOCK

The junction block is mounted on the right cowl side inner panel below the right end of the instrument panel. It is concealed behind the right cowl side trim panel. The junction block serves to simplify and centralize numerous electrical components.

The junction block combines the functions previously provided by a separate fuseblock module and relay center. It contains fuses, circuit breakers and relays. It also eliminates the need for numerous splice connections and serves in place of a bulkhead connector between many of the engine compartment, instrument panel, and body wire harnesses.

The right cowl side trim panel has a snap-fit fuse access cover that can be removed for service of the junction block fuses. A fuse puller and spare fuse holders are located on the back of the fuse access

GENERAL INFORMATION (Continued)

panel. The right cowl side trim panel must be removed to access the relays in the junction block.

The junction block cannot be repaired and, if faulty or damaged, it must be replaced.

DESCRIPTION AND OPERATION

COOLANT TEMPERATURE GAUGE

The coolant temperature gauge gives an indication of the engine coolant temperature. The instrument cluster circuitry controls the gauge pointer position. The instrument cluster circuitry calculates the proper gauge pointer position based upon an engine coolant temperature message received from the Powertrain Control Module (PCM) on the Chrysler Collision Detection (CCD) data bus.

The PCM uses an input from the engine coolant temperature sensor and internal programming to decide what engine coolant temperature message is required. The PCM then sends the proper message to the instrument cluster and the Body Control Module (BCM) on the CCD data bus.

The BCM also monitors the PCM engine coolant temperature messages. If the PCM message indicates that coolant temperature is high or critical, the BCM sends a message to the instrument cluster to turn on the Check Gauges lamp and to move the coolant temperature gauge needle to the corresponding high or critical position of the gauge scale.

The engine coolant temperature sensor is installed in a threaded hole that penetrates a coolant passage of the engine. It is a thermistor-type sensor that changes its internal resistance with changes in engine coolant temperature. Refer to Group 14 - Fuel Systems for more information on the PCM and the coolant temperature sensor.

FUEL GAUGE

The fuel gauge gives an indication of the level of fuel in the fuel tank. The instrument cluster circuitry controls the gauge pointer position. The instrument cluster circuitry calculates the proper gauge pointer position based upon a fuel level message received from the Powertrain Control Module (PCM) on the Chrysler Collision Detection (CCD) data bus.

The PCM uses an input from the fuel gauge sending unit and internal programming to decide what fuel level message is required. The PCM then sends the proper message to the instrument cluster and the Body Control Module (BCM) on the CCD data bus.

The BCM monitors the PCM fuel level messages. If the PCM message indicates that the fuel level is below one-eighth of a full tank, the BCM issues a single audible low fuel chime tone and sends a message to the instrument cluster to turn on the low fuel warning lamp. If the PCM detects a short or

open in the fuel level sending unit circuit, it sends a message on the CCD data bus that will cause the instrument cluster circuitry to position the fuel gauge needle at the Empty stop.

The fuel gauge sending unit is mounted to the electric fuel pump module located inside the fuel tank. The sending unit has a float attached to the end of a swing-arm. The float moves up or down within the fuel tank as the fuel level changes. As the float moves, an electrical contact on the pivot end of the swing-arm wipes across a resistor coil, which changes the internal electrical resistance of the sending unit. Refer to Group 14 - Fuel Systems for more information on the PCM and for the fuel gauge sending unit service procedures.

ODOMETER AND TRIP ODOMETER

The odometer and the trip odometer share the same vacuum fluorescent digital display tube in the instrument cluster circuit board. Each gives an indication of the distance the vehicle has travelled. However, by depressing the reset knob on the face of the instrument cluster, the display mode can be switched from odometer to trip odometer. Depressing the reset knob for longer than two seconds while in the trip odometer mode will reset the trip odometer to zero. The odometer and trip odometer display values are based on distance messages received from the Body Control Module (BCM) on the Chrysler Collision Detection (CCD) data bus.

The BCM uses a distance pulse message relayed from the Powertrain Control Module (PCM) on the CCD data bus and internal programming to decide what distance message is required. The PCM receives the distance pulse signal input from the Vehicle Speed Sensor (VSS) to relay to the BCM on the CCD data bus. The BCM stores both the odometer and trip odometer distance information and sends the proper value to the instrument cluster based upon ignition key-on and trip odometer reset knob messages received on the CCD data bus.

If the instrument cluster is not receiving distance information on the CCD data bus when the ignition switch is turned to the On position, the odometer display will remain blank. If the instrument cluster does not receive a distance message on the CCD data bus after the ignition switch has been turned to the On position, the instrument panel circuitry will insert the last normally displayed distance in the odometer display.

The VSS is a hall-effect sensor that is installed in the transmission (two-wheel drive) or transfer case (four-wheel drive), and is driven by the output shaft through a speedometer pinion gear. Incorrect tire size, incorrect axle ratio, a faulty or incorrect speedometer pinion gear, or a faulty VSS can each result

DESCRIPTION AND OPERATION (Continued)

in inaccurate odometer readings. Refer to Group 14 - Fuel Systems for more information on the PCM and the VSS. Refer to Group 21 - Transmission for more information on the speedometer pinion gear.

OIL PRESSURE GAUGE

The oil pressure gauge gives an indication of the engine oil pressure. The instrument cluster circuitry controls the gauge pointer position. The instrument cluster circuitry calculates the proper gauge pointer position based upon an engine oil pressure message received from the Powertrain Control Module (PCM) on the Chrysler Collision Detection (CCD) data bus.

The PCM uses an input from the engine oil pressure sensor and internal programming to decide what engine oil pressure message is required. The PCM then sends the proper message to the instrument cluster and the Body Control Module (BCM) on the CCD data bus.

The BCM also monitors the PCM engine oil pressure messages. If the PCM message indicates that engine oil pressure is low, the BCM sends a message to the instrument cluster to turn on the Check Gauges lamp and to move the oil pressure gauge needle to the zero end of the gauge scale.

The engine oil pressure sensor is installed in a threaded hole that penetrates an oil passage of the engine. The engine oil pressure sensor contains a flexible diaphragm and a variable resistor coil. The diaphragm moves in response to changes in the engine oil pressure, which changes the internal electrical resistance of the sensor. Refer to Group 14 - Fuel Systems for more information on the PCM and the engine oil pressure sensor.

SPEEDOMETER

The speedometer gives an indication of the current vehicle speed. The instrument cluster circuitry controls the gauge pointer position. The instrument cluster circuitry calculates the proper gauge pointer position based upon a vehicle speed message received from the Powertrain Control Module (PCM) on the Chrysler Collision Detection (CCD) data bus.

The PCM uses an input from the Vehicle Speed Sensor (VSS) and internal programming to decide what vehicle speed message is required. The PCM then sends the proper message to the instrument cluster on the CCD data bus.

The VSS is a hall-effect sensor that is installed in the transmission (two-wheel drive) or transfer case (four-wheel drive), and is driven by the output shaft through a speedometer pinion gear. Incorrect tire size, incorrect axle ratio, a faulty or incorrect speedometer pinion gear, or a faulty VSS can each result in inaccurate speedometer readings.

Refer to Group 14 - Fuel Systems for more information on the PCM and the VSS. Refer to Group 21 - Transmission for more information on the speedometer pinion gear.

TACHOMETER

The tachometer gives an indication of the engine speed in revolutions-per-minute (RPM). The instrument cluster circuitry controls the gauge pointer position. The instrument cluster circuitry calculates the proper gauge pointer position based upon an engine speed message received from the Powertrain Control Module (PCM) on the Chrysler Collision Detection (CCD) data bus.

The PCM uses an input from the crankshaft position sensor and internal programming to decide what engine speed message is required. The PCM then sends the proper message to the instrument cluster on the CCD data bus. The crankshaft position sensor is a hall-effect sensor installed near the rear of the engine, where it is aimed at the trigger wheel attached to the rear flange of the crankshaft.

Refer to Group 14 Fuel Systems for more information on the PCM. Refer to Group 8D - Ignition Systems for more information on the crankshaft position sensor.

VOLTMETER

The voltmeter gives an indication of the electrical system voltage. The instrument cluster circuitry controls the gauge pointer position. The instrument cluster circuitry calculates the proper gauge pointer position based upon a system voltage message received from the Powertrain Control Module (PCM) on the Chrysler Collision Detection (CCD) data bus.

The PCM uses an input from the electrical system and internal programming to decide what system voltage message is required. The PCM then sends the proper message to the instrument cluster on the CCD data bus.

Refer to Group 14 - Fuel System for more information on the PCM. Refer to Group 8C - Charging System for more information on charging system components and diagnosis.

AIRBAG INDICATOR LAMP

The airbag indicator lamp gives an indication when the airbag system is faulty or inoperative. The lamp is turned on by the instrument cluster circuitry for about seven seconds when the ignition switch is turned to the On position as a bulb test. After the bulb test, the lamp is controlled by the instrument cluster circuitry based upon a message received from the Airbag Control Module (ACM) on the Chrysler Collision Detection (CCD) data bus.

DESCRIPTION AND OPERATION (Continued)

The ACM continually monitors the airbag system circuits and sensors to decide whether the system is in good operating condition. The ACM then sends the proper message to the instrument cluster on the CCD data bus to turn the lamp on or off. If the ACM sends a lamp-on message after the bulb test, it indicates that the ACM has detected a system malfunction and/or that the airbag system has become inoperative. Each time the instrument cluster circuitry receives a lamp-on message from the ACM, it will light the lamp for twelve seconds or the duration of the airbag system malfunction, whichever is longer.

The airbag indicator lamp also has a lamp backup feature. Following the seat belt reminder lamp display function, if an inoperative airbag warning lamp circuit was detected during the bulb test sequence, the instrument cluster circuitry will flash the seat belt reminder lamp on and off for about twenty seconds. If the seat belt reminder lamp flashes longer than twenty seconds, or flashes at any time other than about twenty seconds after the initial ignition-on sequence, it indicates an airbag system fault has been detected and that the airbag indicator lamp is inoperative.

Refer to Group 8M - Passive Restraint Systems for more information on the airbag system.

ANTI-LOCK BRAKE SYSTEM LAMP

The Anti-Lock Brake System (ABS) lamp gives an indication when the ABS system is faulty or inoperative. The lamp is hard-wired in the instrument cluster, and is completely controlled by the Controller Anti-lock Brake (CAB).

The ABS lamp receives battery voltage through the instrument cluster fused ignition switch output feed circuit, and is grounded by the CAB. The lamp is turned on by the CAB for about two seconds when the ignition switch is turned to the On position as a bulb test. After the bulb test, the CAB turns the lamp on or off based upon the results of the ABS system self-tests.

The CAB continually monitors the ABS circuits and sensors to decide whether the system is in good operating condition. If the CAB turns the lamp on after the bulb test, it indicates that the CAB has detected a system malfunction and/or that the ABS system has become inoperative. Refer to Group 5 - Brakes for more information.

BRAKE WARNING LAMP

The brake warning lamp gives an indication when the parking brake is applied, or when the pressures in the two halves of the split brake hydraulic system are unequal. The lamp is turned on by the instrument cluster circuitry for about four seconds when

the ignition switch is turned to the On position as a bulb test. After the bulb test, the lamp is controlled by the instrument cluster circuitry based upon a message received from the Body Control Module (BCM) on the Chrysler Collision Detection (CCD) data bus.

The BCM uses inputs from the parking brake switch and the brake warning switch to decide whether the brake warning lamp should be on or off. The BCM then sends the proper message to the instrument cluster on the CCD data bus to turn the lamp on or off.

The brake warning switch closes to ground when it senses unequal hydraulic pressures in the two halves of the split brake hydraulic system, possibly due to low brake fluid level or brake fluid leakage. The parking brake switch closes to ground when the parking brake is applied. Refer to Group 5 - Brakes for more information.

CHECK GAUGES LAMP

The check gauges lamp gives an indication when certain gauges reflect a condition requiring immediate attention. The lamp is turned on by the instrument cluster circuitry for about three seconds after the ignition switch is turned to the On position as a bulb test. After the bulb test, the lamp is controlled by the instrument cluster circuitry based upon gauge data messages received from either the Body Control Module (BCM) or the Powertrain Control Module (PCM) on the Chrysler Collision Detection (CCD) data bus.

The BCM and PCM use several inputs to decide whether a condition exists requiring the check gauges lamp to be turned on. The responsible module then sends the proper message to the instrument cluster on the CCD data bus to turn the lamp on or off. When the instrument cluster circuitry receives a check gauges lamp-on message, it sends a chime request message to the BCM on the CCD data bus for a chime tone to sound.

The gauge data messages for which the instrument cluster is programmed to turn on the check gauges lamp and the responsible modules are:

- Engine coolant temperature is high or critical (BCM)
- Engine oil pressure is low (BCM)
- Charging system failure (PCM)
- System voltage is high (PCM).

CIGAR LIGHTER

A cigar lighter is standard equipment on this model. The cigar lighter is located in the instrument panel center bezel, near the ash receiver. The cigar lighter base is secured by a snap fit within an illuminated light ring and retainer unit. The light ring

DESCRIPTION AND OPERATION (Continued)

is illuminated by a small, replaceable incandescent bulb, which is controlled by the instrument panel lamp dimmer circuit.

The cigar lighter consists of two major components: a knob and heating element unit, and the cigar lighter base or receptacle shell. The receptacle shell is connected to ground, and an insulated contact in the bottom of the shell is connected to battery current. The cigar lighter receives battery voltage from a fuse in the junction block through the cigar lighter relay only when the ignition switch is in the Accessory or On positions. See Cigar Lighter Relay in this group for more information.

The knob and heating element are encased within a spring-loaded housing, which also features a sliding protective heat shield. When the knob and heating element are inserted in the receptacle shell, the heating element resistor coil is grounded through its housing to the receptacle shell. If the cigar lighter knob is pushed inward, the heat shield slides up toward the knob exposing the heating element, and the heating element extends from the housing toward the insulated contact in the bottom of the receptacle shell.

Two small spring-clip retainers are located on either side of the insulated contact inside the bottom of the receptacle shell. These clips engage and hold the heating element against the insulated contact long enough for the resistor coil to heat up. When the heating element is engaged with the contact, battery current can flow through the resistor coil to ground, causing the resistor coil to heat.

When the resistor coil becomes sufficiently heated, excess heat radiates from the heating element causing the spring-clips to expand. Once the spring-clips expand far enough to release the heating element, the spring-loaded housing forces the knob and heating element to pop back outward to their relaxed position. When the cigar lighter knob and element are pulled out of the receptacle shell, the protective heat shield slides downward on the housing so that the heating element is recessed and shielded around its circumference for safety.

The cigar lighter knob and heating element unit, the cigar lighter base unit, and the light ring and retainer unit are available for service. These cigar lighter components cannot be repaired and, if damaged or faulty, they must be replaced.

CIGAR LIGHTER RELAY

The cigar lighter relay is a International Standards Organization (ISO) micro-relay. The terminal designations and functions are the same as a conventional ISO relay. However, the micro-relay terminal orientation (or footprint) is different, current capacity is

lower, and the relay case dimensions are smaller than those of the conventional ISO relay.

The cigar lighter relay is a electromechanical device that switches fused battery current to the cigar lighter when the ignition switch is turned to the Accessory or On positions. See the Diagnosis and Testing section of this group for more information on the operation of the cigar lighter relay.

The cigar lighter relay is located in the junction block, on the right cowl side panel below the instrument panel in the passenger compartment. The cigar lighter relay cannot be repaired and, if faulty or damaged, it must be replaced.

CLUSTER ILLUMINATION LAMP

When the park or head lamps are on, the cluster illumination lamps light. Illumination brightness is adjusted by sliding the panel dimmer switch knob (downwards to dim, upwards to brighten). Each of the instrument cluster illumination lamps receives pulse-width modulated battery feed from the Body Control Module (BCM) on the hard-wired panel lamps driver circuit. The BCM monitors the panel dimmer resistor switch to determine the desired dimming level, then adjusts the pulse-width signal accordingly.

The BCM also sends the proper panel lamps dimming level message on the Chrysler Collision Detection (CCD) data bus to control the dimming levels of the various vacuum fluorescent displays. All modules on the CCD data bus with vacuum fluorescent displays (instrument cluster, radio, mini trip computer, vehicle information center) receive this message and adjust their dimming levels to match that of the incandescent cluster illumination bulbs driven directly by the BCM.

Vehicles equipped with the automatic headlamps option have an automatic funeral mode or parade mode. In this mode, the BCM uses an input from the automatic headlamp light sensor to determine the ambient light levels. If the BCM decides that the exterior lighting is turned on in the daylight, it overrides the selected panel dimmer switch signal by sending a message on the CCD bus to illuminate all vacuum fluorescent displays at full brightness for easier visibility in daytime light levels. The automatic funeral mode or parade mode has no effect on the incandescent bulb dimming levels.

Each of the cluster illumination lamps is located on the instrument cluster circuit board. Each lamp has a replaceable bulb and bulb holder. Refer to Group 8L - Lamps for more information.

CRUISE-ON INDICATOR LAMP

The cruise-on indicator lamp gives an indication when the vehicle speed control system is turned on,

DESCRIPTION AND OPERATION (Continued)

even when the system is not currently engaged. The lamp is turned on by the instrument cluster circuitry for about four seconds when the ignition switch is turned to the On position as a bulb test. After the bulb test, the lamp is controlled by the instrument cluster circuitry based upon a message received from the Powertrain Control Module (PCM) on the Chrysler Collision Detection (CCD) data bus.

The PCM uses an input from the analog resistor-multiplexed vehicle speed control switches in the steering wheel to decide whether to turn the lamp on or off. The PCM then sends the proper message to the instrument cluster on the CCD data bus. Refer to Group 8H - Vehicle Speed Control System for more information.

HEADLAMP HIGH BEAM INDICATOR LAMP

The headlamp high beam indicator lamp gives an indication when the headlamp high beams are turned on. The lamp is turned on by the instrument cluster circuitry for about four seconds when the ignition switch is turned to the On position as a bulb test. After the bulb test, the lamp is controlled by the instrument cluster circuitry based upon a message received from the Body Control Module (BCM) on the Chrysler Collision Detection (CCD) data bus.

The BCM uses an input from the headlamp dimmer (multi-function) switch to decide whether the headlamp high beams are turned on. It then sends the proper message to the instrument cluster on the CCD data bus to turn the lamp on or off. Refer to Group 8L - Lamps for more information.

LOW FUEL WARNING LAMP

The low fuel warning lamp gives an indication when the fuel level in the fuel tank has fallen below about one-eighth of a full tank, as registered on the fuel gauge. The instrument cluster circuitry lights the lamp for about four seconds when the ignition switch is turned to the On position as a bulb test. After the bulb test, the instrument cluster circuitry controls the lamp based upon a fuel level message received from the Body Control Module (BCM) on the Chrysler Collision Detection (CCD) data bus.

The BCM uses a fuel level message received from the Powertrain Control Module (PCM) on the CCD data bus to decide when the fuel level is low. The BCM then sends the proper message to the instrument cluster on the CCD data bus. When the lamp-on message is sent, the BCM also issues a single low fuel warning chime tone. Once the lamp is turned on, an increase in the fuel level of at least one-half gallon is required before the PCM input to the BCM will change and cause a lamp-off message to be issued. If the PCM detects a short or open in the fuel gauge sending unit circuit, it sends a mes-

sage on the CCD data bus that will cause the fuel gauge pointer to move to the empty stop and the low fuel lamp to be turned on.

Refer to Group 14 - Fuel Systems for more information on the PCM and its inputs.

MALFUNCTION INDICATOR LAMP

The Check Engine or Malfunction Indicator Lamp (MIL) gives an indication when the Powertrain Control Module (PCM) has recorded a Diagnostic Trouble Code (DTC) for an On-Board Diagnostics II (OBDII) emissions-related circuit or component malfunction. The lamp is turned on by the instrument cluster circuitry for about three seconds when the ignition switch is turned to the On position as a bulb test. After the bulb test, the lamp is controlled by the instrument cluster circuitry based upon messages received from the PCM on the Chrysler Collision Detection (CCD) data bus.

The PCM uses inputs from many emissions-related circuits and sensors, along with its internal programming, to decide whether a condition exists that requires the MIL lamp to be turned on. The PCM then sends the proper message to the instrument cluster on the CCD data bus to turn the lamp on or off. When the instrument cluster circuitry receives a MIL lamp-on message from the PCM, it sends a chime request message to the Body Control Module (BCM) on the CCD data bus for a single chime tone to sound.

The MIL lamp can also be used to display a stored DTC by flashing on and off. Refer to Group 14 - Fuel Systems for more information on the PCM or the PCM inputs. Refer to Group 25 - Emission Control Systems for more information on DTCs and their retrieval.

POWER OUTLET

An accessory power outlet is standard equipment on this model. The power outlet is located in the instrument panel center bezel, near the ash receiver. A hinged plastic door on the center bezel covers the power outlet when it is not being used.

The power outlet base or receptacle shell is connected to ground, and an insulated contact in the bottom of the shell is connected to battery current. The power outlet receives battery voltage from a fuse in the junction block at all times.

While the power outlet is very similar to a cigar lighter base unit, it does not include the two small spring-clip retainers inside the bottom of the receptacle shell that are used to secure the cigar lighter heating element to the insulated contact. Also, the power outlet is not illuminated and uses a different mounting system to secure it to the center bezel than the cigar lighter base.

DESCRIPTION AND OPERATION (Continued)

The power outlet cannot be repaired and, if faulty or damaged, it must be replaced. The power outlet door is available for service.

SEAT BELT REMINDER LAMP

The seat belt reminder lamp gives a visual reminder to the vehicle occupants to fasten their seat belts. The lamp is turned on by the instrument cluster circuitry for about seven seconds when the ignition switch is turned to the On position.

If the driver seat belt switch is closed (seat belt is not buckled), the Body Control Module (BCM) will also sound a chime warning for the duration of the seat belt reminder lamp illumination. The chime warning will stop when the driver seat belt switch is open (seat belt is buckled).

The seat belt reminder lamp also serves as a backup for the airbag indicator lamp. Following the seat belt reminder lamp seven second display function, if the instrument cluster circuitry has detected an inoperative airbag indicator lamp circuit it will flash the seat belt reminder lamp on and off for twenty seconds. If the seat belt reminder lamp flashes longer than twenty seconds, or flashes at any time other than immediately after the initial seven second seat belt reminder lamp display, it indicates an airbag system fault has been detected and that the airbag indicator lamp is inoperative.

Refer to Group 8U - Chime/Buzzer Warning Systems for more information on the driver seat belt switch.

TURN SIGNAL INDICATOR LAMP

The left and right turn signal indicator lamps give an indication when the turn signal circuits are activated. The lamps are hard-wired in the instrument cluster, and are completely controlled by the turn signal and hazard warning (multi-function) switches.

The indicator lamps are grounded at all times and receive battery feed through the contacts of the multi-function switch when the turn signal lever (multi-function switch stalk) or the hazard warning button are actuated to their On positions. The instrument cluster circuitry does not perform a bulb test of these lamps. Refer to Group 8J - Turn Signal and Hazard Warning Systems for more information.

DIAGNOSIS AND TESTING

INSTRUMENT CLUSTER

All of the gauges and many of the indicator lamps in the instrument cluster are controlled by messages received by the instrument cluster circuitry on the CCD data bus. Only the cluster illumination lamps, anti-lock brake system lamp, turn signal indicator lamps, and the master lighting indicator lamp (if the

vehicle is so equipped) are hard-wired in the gauge cluster.

If an individual gauge or lamp is inoperative, see the diagnostic procedure under the heading for that gauge or lamp. For circuit descriptions and diagrams, refer to 8W-40 - Instrument Cluster in Group 8W - Wiring Diagrams. If more than one gauge or lamp is inoperative, perform the following:

WARNING: ON VEHICLES EQUIPPED WITH AIRBAGS, REFER TO GROUP 8M - PASSIVE RESTRAINT SYSTEMS BEFORE ATTEMPTING ANY STEERING WHEEL, STEERING COLUMN, OR INSTRUMENT PANEL COMPONENT DIAGNOSIS OR SERVICE. FAILURE TO TAKE THE PROPER PRECAUTIONS COULD RESULT IN ACCIDENTAL AIRBAG DEPLOYMENT AND POSSIBLE PERSONAL INJURY.

(1) Check the fuses in the junction block module. If OK, go to Step 2. If not OK, repair the shorted circuit or component as required and replace the faulty fuse.

(2) Check for battery voltage at the fused B+ fuse in the junction block. If OK, go to Step 3. If not OK, repair the open circuit to the fuse in the Power Distribution Center (PDC) as required.

(3) Turn the ignition switch to the On position. Check for battery voltage at the fused ignition switch output (start/run) fuse in the junction block. If OK, go to Step 4. If not OK, repair the open circuit to the fuse in the Power Distribution Center (PDC) as required.

(4) Turn the ignition switch to the Off position. Disconnect and isolate the battery negative cable. Remove the instrument cluster as described in this group. Connect the battery negative cable. Check for battery voltage at the fused B(+) circuit cavity of the instrument cluster wire harness connector. If OK, go to Step 5. If not OK, repair the open circuit from the fuse in the junction block as required.

(5) Turn the ignition switch to the On position. Check for battery voltage at the fused ignition switch output (start/run) circuit cavity of the instrument cluster wire harness connector. If OK, go to Step 6. If not OK, repair the open circuit from the fuse in the junction block as required.

(6) Turn the ignition switch to the Off position. Disconnect and isolate the battery negative cable. Probe each of the ground circuit cavities of the instrument cluster wire harness connector. Check for continuity to a good ground. There should be continuity. If OK, refer to the proper Diagnostic Procedures manual for further testing of the instrument cluster circuitry and the CCD data bus with a DRB scan tool. If not OK, repair the open circuit(s) to ground as required.

DIAGNOSIS AND TESTING (Continued)**COOLANT TEMPERATURE GAUGE**

If the problem being diagnosed is related to coolant temperature gauge accuracy, be certain to confirm that the problem is with the gauge and not with cooling system performance. The actual engine coolant temperature should be checked with a test gauge or thermometer and compared to the instrument cluster coolant temperature gauge readings before you proceed with gauge diagnosis. Refer to Group 7 - Cooling System for more information. Refer to Group 8W - Wiring Diagrams for circuit descriptions and diagrams.

WARNING: ON VEHICLES EQUIPPED WITH AIR-BAGS, REFER TO GROUP 8M - PASSIVE RESTRAINT SYSTEMS BEFORE ATTEMPTING ANY STEERING WHEEL, STEERING COLUMN, OR INSTRUMENT PANEL COMPONENT DIAGNOSIS OR SERVICE. FAILURE TO TAKE THE PROPER PRECAUTIONS COULD RESULT IN ACCIDENTAL AIR-BAG DEPLOYMENT AND POSSIBLE PERSONAL INJURY.

Diagnosis of the coolant temperature sensor and circuit, the Chrysler Collision Detection (CCD) data bus, and/or the Powertrain Control Module (PCM) should be performed with a DRB scan tool as described in the proper Diagnostic Procedures manual. For further diagnosis of the coolant temperature gauge and the instrument cluster circuitry, see Instrument Cluster in this group.

FUEL GAUGE

If the problem being diagnosed is related to fuel gauge accuracy, be certain to confirm that the problem is with the gauge or sending unit and not with the fuel tank. Inspect the fuel tank for signs of damage or distortion that could affect the sending unit performance before you proceed with fuel gauge diagnosis. Refer to Group 8W - Wiring Diagrams for circuit descriptions and diagrams.

WARNING: ON VEHICLES EQUIPPED WITH AIR-BAGS, REFER TO GROUP 8M - PASSIVE RESTRAINT SYSTEMS BEFORE ATTEMPTING ANY STEERING WHEEL, STEERING COLUMN, OR INSTRUMENT PANEL COMPONENT DIAGNOSIS OR SERVICE. FAILURE TO TAKE THE PROPER PRECAUTIONS COULD RESULT IN ACCIDENTAL AIR-BAG DEPLOYMENT AND POSSIBLE PERSONAL INJURY.

Diagnosis of the fuel gauge sending unit and circuit, the Chrysler Collision Detection (CCD) data bus, and/or the Powertrain Control Module (PCM) should be performed with a DRB scan tool as described in the proper Diagnostic Procedures man-

ual. For further diagnosis of the fuel gauge and the instrument cluster circuitry, see Instrument Cluster in this group.

ODOMETER AND TRIP ODOMETER

If the problem being diagnosed is related to odometer and/or trip odometer accuracy, be certain to confirm that the problem is with the display and not with an incorrect speedometer pinion gear, axle ratio, or tire size. Refer to Group 21 - Transmission for more information on the speedometer pinion gear. Refer to Group 8W - Wiring Diagrams for circuit descriptions and diagrams.

WARNING: ON VEHICLES EQUIPPED WITH AIR-BAGS, REFER TO GROUP 8M - PASSIVE RESTRAINT SYSTEMS BEFORE ATTEMPTING ANY STEERING WHEEL, STEERING COLUMN, OR INSTRUMENT PANEL COMPONENT DIAGNOSIS OR SERVICE. FAILURE TO TAKE THE PROPER PRECAUTIONS COULD RESULT IN ACCIDENTAL AIR-BAG DEPLOYMENT AND POSSIBLE PERSONAL INJURY.

Diagnosis of the vehicle speed sensor and circuit, the Chrysler Collision Detection (CCD) data bus, the Body Control Module (BCM) and/or the Powertrain Control Module (PCM) should be performed with a DRB scan tool as described in the proper Diagnostic Procedures manual. For further diagnosis of the odometer and/or trip odometer and the instrument cluster circuitry, see Instrument Cluster in this group.

OIL PRESSURE GAUGE

If the problem being diagnosed is related to oil pressure gauge accuracy, be certain to confirm that the problem is with the gauge and not with the engine oiling system performance. The actual engine oil pressure should be checked with a test gauge and compared to the instrument cluster oil pressure gauge readings before you proceed with gauge diagnosis. Refer to Group 9 - Engines for more information. Refer to Group 8W - Wiring Diagrams for circuit descriptions and diagrams.

WARNING: ON VEHICLES EQUIPPED WITH AIR-BAGS, REFER TO GROUP 8M - PASSIVE RESTRAINT SYSTEMS BEFORE ATTEMPTING ANY STEERING WHEEL, STEERING COLUMN, OR INSTRUMENT PANEL COMPONENT DIAGNOSIS OR SERVICE. FAILURE TO TAKE THE PROPER PRECAUTIONS COULD RESULT IN ACCIDENTAL AIR-BAG DEPLOYMENT AND POSSIBLE PERSONAL INJURY.

DIAGNOSIS AND TESTING (Continued)

Diagnosis of the oil pressure sensor and circuit, the Chrysler Collision Detection (CCD) data bus, and/or the Powertrain Control Module (PCM) should be performed with a DRB scan tool as described in the proper Diagnostic Procedures manual. For further diagnosis of the oil pressure gauge and the instrument cluster circuitry, see Instrument Cluster in this group.

SPEEDOMETER

If the problem being diagnosed is related to speedometer accuracy, be certain to confirm that the problem is with the speedometer gauge and not with an incorrect speedometer pinion gear, axle ratio, or tire size. Refer to Group 21 - Transmission for more information on the speedometer pinion gear. Refer to Group 8W - Wiring Diagrams for circuit descriptions and diagrams.

WARNING: ON VEHICLES EQUIPPED WITH AIRBAGS, REFER TO GROUP 8M - PASSIVE RESTRAINT SYSTEMS BEFORE ATTEMPTING ANY STEERING WHEEL, STEERING COLUMN, OR INSTRUMENT PANEL COMPONENT DIAGNOSIS OR SERVICE. FAILURE TO TAKE THE PROPER PRECAUTIONS COULD RESULT IN ACCIDENTAL AIRBAG DEPLOYMENT AND POSSIBLE PERSONAL INJURY.

Diagnosis of the vehicle speed sensor and circuit, the Chrysler Collision Detection (CCD) data bus, and/or the Powertrain Control Module (PCM) should be performed with a DRB scan tool as described in the proper Diagnostic Procedures manual. For further diagnosis of the speedometer and the instrument cluster circuitry, see Instrument Cluster in this group.

TACHOMETER

WARNING: ON VEHICLES EQUIPPED WITH AIRBAGS, REFER TO GROUP 8M - PASSIVE RESTRAINT SYSTEMS BEFORE ATTEMPTING ANY STEERING WHEEL, STEERING COLUMN, OR INSTRUMENT PANEL COMPONENT DIAGNOSIS OR SERVICE. FAILURE TO TAKE THE PROPER PRECAUTIONS COULD RESULT IN ACCIDENTAL AIRBAG DEPLOYMENT AND POSSIBLE PERSONAL INJURY.

Refer to Group 8W - Wiring Diagrams for circuit descriptions and diagrams. Diagnosis of the crankshaft position sensor and circuit, the Chrysler Collision Detection (CCD) data bus, and/or the Powertrain Control Module (PCM) should be performed with a DRB scan tool as described in the proper Diagnostic Procedures manual. For further diagnosis of the

tachometer and the instrument cluster circuitry, see Instrument Cluster in this group.

VOLTMETER

If the problem being diagnosed is related to voltmeter gauge accuracy, be certain to confirm proper charging system operation before considering gauge replacement. Refer to Group 8C - Charging System for more information. Refer to Group 8W - Wiring Diagrams for circuit descriptions and diagrams.

WARNING: ON VEHICLES EQUIPPED WITH AIRBAGS, REFER TO GROUP 8M - PASSIVE RESTRAINT SYSTEMS BEFORE ATTEMPTING ANY STEERING WHEEL, STEERING COLUMN, OR INSTRUMENT PANEL COMPONENT DIAGNOSIS OR SERVICE. FAILURE TO TAKE THE PROPER PRECAUTIONS COULD RESULT IN ACCIDENTAL AIRBAG DEPLOYMENT AND POSSIBLE PERSONAL INJURY.

Diagnosis of the system voltage input circuit, the Chrysler Collision Detection (CCD) data bus, and/or the Powertrain Control Module (PCM) should be performed with a DRB scan tool as described in the proper Diagnostic Procedures manual. For further diagnosis of the voltmeter and the instrument cluster circuitry, see Instrument Cluster in this group.

AIRBAG INDICATOR LAMP

The diagnosis found here addresses an inoperative airbag indicator lamp condition. If the airbag indicator lamp stays on with the ignition switch in the On position, or comes on and stays on while driving, refer to Group 8M - Passive Restraint Systems for diagnosis. For circuit descriptions and diagrams, refer to 8W-40 - Instrument Cluster, 8W-43 - Airbag System, and 8W-45 - Body Control Module in Group 8W - Wiring Diagrams.

WARNING: ON VEHICLES EQUIPPED WITH AIRBAGS, REFER TO GROUP 8M - PASSIVE RESTRAINT SYSTEMS BEFORE ATTEMPTING ANY STEERING WHEEL, STEERING COLUMN, OR INSTRUMENT PANEL COMPONENT DIAGNOSIS OR SERVICE. FAILURE TO TAKE THE PROPER PRECAUTIONS COULD RESULT IN ACCIDENTAL AIRBAG DEPLOYMENT AND POSSIBLE PERSONAL INJURY.

The airbag indicator lamp has a lamp backup feature. Following the seat belt reminder lamp display function, if the instrument cluster circuitry has detected an inoperative airbag warning lamp circuit it will flash the seat belt reminder lamp on and off for twenty seconds. Once the instrument cluster circuitry has detected an inoperative airbag warning

DIAGNOSIS AND TESTING (Continued)

lamp circuit, if a lamp-on message is received from the Airbag Control Module (ACM) on the Chrysler Collision Detection (CCD) data bus, the seatbelt reminder lamp will flash for twelve seconds or the duration of the airbag system malfunction, whichever is longer.

If the airbag indicator lamp fails to light when the ignition switch is turned to the On position, and the seat belt reminder lamp flashes following its normal display function (about seven seconds after the ignition switch is turned to the On position), replace the airbag indicator lamp bulb with a known good unit. If the airbag indicator lamp still fails to operate, diagnosis of the airbag lamp, the instrument cluster circuitry, the CCD data bus, and the Body Control Module (BCM) should be performed with a DRB scan tool as described in the proper Diagnostic Procedures manual. For further diagnosis of the airbag indicator lamp and the instrument cluster circuitry, see Instrument Cluster in this group.

ANTI-LOCK BRAKE SYSTEM LAMP

The diagnosis found here addresses an inoperative Anti-lock Brake System (ABS) lamp condition. If the ABS lamp stays on with the ignition switch in the On position, or comes on and stays on while driving, refer to Group 5 - Brakes for diagnosis. If no ABS problem is found, the following procedure will help locate a short or open in the ABS lamp circuit. For circuit descriptions and diagrams, refer to 8W-40 - Instrument Cluster, and 8W-35 - All-Wheel Anti-Lock Brakes in Group 8W - Wiring Diagrams.

WARNING: ON VEHICLES EQUIPPED WITH AIRBAGS, REFER TO GROUP 8M - PASSIVE RESTRAINT SYSTEMS BEFORE ATTEMPTING ANY STEERING WHEEL, STEERING COLUMN, OR INSTRUMENT PANEL COMPONENT DIAGNOSIS OR SERVICE. FAILURE TO TAKE THE PROPER PRECAUTIONS COULD RESULT IN ACCIDENTAL AIRBAG DEPLOYMENT AND POSSIBLE PERSONAL INJURY.

(1) Check the fuse in the junction block. If OK, go to Step 2. If not OK, repair the shorted circuit or component as required and replace the faulty fuse.

(2) Turn the ignition switch to the On position. Check for battery voltage at the fuse in the junction block. If OK, go to Step 3. If not OK, repair the open circuit to the ignition switch as required.

(3) Turn the ignition switch to the Off position. Disconnect and isolate the battery negative cable. Remove the instrument cluster. Connect the battery negative cable. Turn the ignition switch to the On position and within five seconds check for battery voltage between the fused ignition switch output circuit and the ABS warning lamp driver circuit cavities

of the instrument cluster wire harness connector. If OK, replace the faulty bulb. If not OK, go to Step 4.

(4) Turn the ignition switch to the Off position. Disconnect and isolate the battery negative cable. Unplug the Controller Anti-lock Brake (CAB) wire harness connector. Check for continuity between the ABS warning lamp driver circuit cavity of the instrument cluster wire harness connector and a good ground. There should be no continuity. If OK, go to Step 5. If not OK, repair the short circuit as required.

(5) Check for continuity between the ABS warning lamp driver circuit cavities of the instrument cluster wire harness connector and the CAB wire harness connector. There should be continuity. If OK, refer to Group 5 - Brakes for diagnosis of the CAB. If not OK, repair the open circuit as required.

BRAKE WARNING LAMP

The diagnosis found here addresses an inoperative brake warning lamp condition. If the brake warning lamp stays on with the ignition switch in the On position and the parking brake released, or comes on while driving, refer to Group 5 - Brakes for diagnosis. If no service brake or parking brake problem is found, proceed as follows. Refer to 8W-40 - Instrument Cluster, 8W-35 - All-Wheel Anti-Lock Brakes, and 8W-45 - Body Control Module in Group 8W - Wiring Diagrams for circuit descriptions and diagrams.

WARNING: ON VEHICLES EQUIPPED WITH AIRBAGS, REFER TO GROUP 8M - PASSIVE RESTRAINT SYSTEMS BEFORE ATTEMPTING ANY STEERING WHEEL, STEERING COLUMN, OR INSTRUMENT PANEL COMPONENT DIAGNOSIS OR SERVICE. FAILURE TO TAKE THE PROPER PRECAUTIONS COULD RESULT IN ACCIDENTAL AIRBAG DEPLOYMENT AND POSSIBLE PERSONAL INJURY.

If the brake warning lamp fails to light during the bulb test (for about four seconds after the ignition switch is turned to the On position), replace the bulb with a known good unit. If the brake warning lamp still fails to operate, diagnosis of the park brake switch and circuit, the brake warning switch and circuit, the Body Control Module (BCM), the instrument cluster circuitry, and/or the CCD data bus should be performed with a DRB scan tool as described in the proper Diagnostic Procedures manual. For further diagnosis of the brake warning lamp and the instrument cluster circuitry, see Instrument Cluster in this group.

DIAGNOSIS AND TESTING (Continued)**CHECK GAUGES LAMP**

The diagnosis found here addresses an inoperative check gauges lamp condition. If the check gauges lamp stays on with the ignition switch in the On position, or comes on while driving with no unusual gauge readings evident, diagnosis of the Powertrain Control Module (PCM), Body Control Module (BCM) and the Chrysler Collision Detection (CCD) data bus should be performed with a DRB scan tool as described in the proper Diagnostic Procedures manual. For circuit descriptions and diagrams, refer to 8W-30 - Fuel/Ignition Systems, 8W-40 - Instrument Cluster, and 8W-45 - Body Control Module in Group 8W - Wiring Diagrams.

WARNING: ON VEHICLES EQUIPPED WITH AIR-BAGS, REFER TO GROUP 8M - PASSIVE RESTRAINT SYSTEMS BEFORE ATTEMPTING ANY STEERING WHEEL, STEERING COLUMN, OR INSTRUMENT PANEL COMPONENT DIAGNOSIS OR SERVICE. FAILURE TO TAKE THE PROPER PRECAUTIONS COULD RESULT IN ACCIDENTAL AIR-BAG DEPLOYMENT AND POSSIBLE PERSONAL INJURY.

If the check gauges lamp fails to light during the bulb test (about three seconds after the ignition switch is turned to the On position), replace the check gauges lamp bulb with a known good unit. If the check gauges lamp still fails to operate, diagnosis of the lamp, the instrument cluster circuitry, the CCD data bus, the BCM and the PCM should be performed with a DRB scan tool as described in the proper Diagnostic Procedures manual. For further diagnosis of the check gauges lamp and the instrument cluster circuitry, see Instrument Cluster in this group.

CIGAR LIGHTER

For circuit descriptions and diagrams, refer to 8W-41 - Horns/Cigar Lighter in Group 8W - Wiring Diagrams.

WARNING: ON VEHICLES EQUIPPED WITH AIR-BAGS, REFER TO GROUP 8M - PASSIVE RESTRAINT SYSTEMS BEFORE ATTEMPTING ANY STEERING WHEEL, STEERING COLUMN, OR INSTRUMENT PANEL COMPONENT DIAGNOSIS OR SERVICE. FAILURE TO TAKE THE PROPER PRECAUTIONS COULD RESULT IN ACCIDENTAL AIR-BAG DEPLOYMENT AND POSSIBLE PERSONAL INJURY.

(1) Remove the cigar lighter knob and element from the cigar lighter receptacle shell. Check for continuity between the inside circumference of the cigar lighter receptacle shell and a good ground. there

should be continuity. If OK, go to Step 2. If not OK, go to Step 3.

(2) Turn the ignition switch to the On position. Check for battery voltage at the insulated contact located at the back of the cigar lighter receptacle shell. If OK, replace the faulty cigar lighter knob and element. If not OK, go to Step 3.

(3) Turn the ignition switch to the Off position. Disconnect and isolate the battery negative cable. Remove the instrument panel center bezel. Check for continuity between the ground circuit cavity of the cigar lighter wire harness connector and a good ground. There should be continuity. If OK, go to Step 4. If not OK, repair the open circuit to ground as required.

(4) Connect the battery negative cable. Turn the ignition switch to the Accessory or On positions. Check for battery voltage at the fused B(+) circuit cavity of the cigar lighter wire harness connector. If OK, replace the faulty cigar lighter receptacle shell unit. If not OK, see the diagnosis for the cigar lighter relay in this group.

CIGAR LIGHTER RELAY

For circuit descriptions and diagrams, refer to 8W-41 - Horns/Cigar Lighter in Group 8W - Wiring Diagrams.

WARNING: ON VEHICLES EQUIPPED WITH AIR-BAGS, REFER TO GROUP 8M - PASSIVE RESTRAINT SYSTEMS BEFORE ATTEMPTING ANY STEERING WHEEL, STEERING COLUMN, OR INSTRUMENT PANEL COMPONENT DIAGNOSIS OR SERVICE. FAILURE TO TAKE THE PROPER PRECAUTIONS COULD RESULT IN ACCIDENTAL AIR-BAG DEPLOYMENT AND POSSIBLE PERSONAL INJURY.

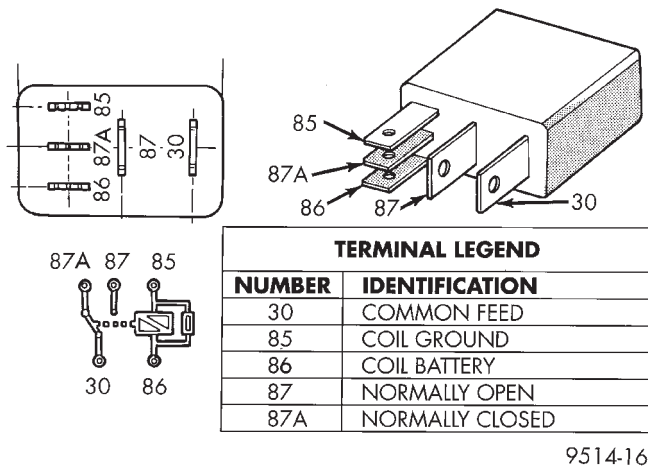
RELAY TEST

The cigar lighter relay (Fig. 1) is located in the junction block, on the right cowl side panel below the instrument panel in the passenger compartment. Remove the cigar lighter relay from the junction block to perform the following tests:

(1) A relay in the de-energized position should have continuity between terminals 87A and 30, and no continuity between terminals 87 and 30. If OK, go to Step 2. If not OK, replace the faulty relay.

(2) Resistance between terminals 85 and 86 (electromagnet) should be 75 ± 5 ohms. If OK, go to Step 3. If not OK, replace the faulty relay.

(3) Connect a battery to terminals 85 and 86. There should now be continuity between terminals 30 and 87, and no continuity between terminals 87A and 30. If OK, see the Relay Circuit Test in this group. If not OK, replace the faulty relay.

DIAGNOSIS AND TESTING (Continued)**Fig. 1 Cigar Lighter Relay****RELAY CIRCUIT TEST**

(1) The relay common feed terminal (30) cavity of the junction block is connected to battery voltage and should be hot at all times. If OK, go to Step 2. If not OK, repair the fused B(+) circuit to the fuse in the junction block as required.

(2) The relay normally closed terminal (87A) is connected to terminal 30 in the de-energized position, but is not used for this application. Go to Step 3.

(3) The relay normally open terminal (87) is connected to the common feed terminal (30) in the energized position. This terminal supplies battery voltage to the cigar lighter when the relay is energized by the ignition switch. There should be continuity between the junction block cavity for relay terminal 87 and the fused B(+) circuit cavity of the cigar lighter wire harness connector at all times. If OK, go to Step 4. If not OK, repair the open circuit to the cigar lighter wire harness connector as required.

(4) The coil battery terminal (86) is connected to the electromagnet in the relay. It receives battery feed to energize the relay when the ignition switch is in the Accessory or On positions. There should be continuity between the junction block cavity for relay terminal 86 and the ignition switch output (acc/run) fuse in the junction block at all times. If OK, go to Step 5. If not OK, repair the open circuit to the junction block fuse as required.

(5) The coil ground terminal (85) is connected to the electromagnet in the relay. There should be continuity between the junction block cavity for relay terminal 85 and a good ground at all times. If not OK, repair the open circuit to ground as required.

CLUSTER ILLUMINATION LAMP

The diagnosis found here addresses an inoperative instrument cluster illumination lamp condition. If the problem being diagnosed is related to the dimming level of the instrument cluster illumination

lamps, diagnosis should be performed with a DRB scan tool as described in the proper Diagnostic Procedures manual. For circuit descriptions and diagrams, refer to 8W-40 - Instrument Cluster, 8W-45 - Body Control Module, and/or 8W-50 - Front Lighting in Group 8W - Wiring Diagrams.

WARNING: ON VEHICLES EQUIPPED WITH AIRBAGS, REFER TO GROUP 8M - PASSIVE RESTRAINT SYSTEMS BEFORE ATTEMPTING ANY STEERING WHEEL, STEERING COLUMN, OR INSTRUMENT PANEL COMPONENT DIAGNOSIS OR SERVICE. FAILURE TO TAKE THE PROPER PRECAUTIONS COULD RESULT IN ACCIDENTAL AIRBAG DEPLOYMENT AND POSSIBLE PERSONAL INJURY.

If only individual instrument cluster illumination lamps are inoperative, replace the faulty bulbs. If all of the instrument cluster illumination lamps are inoperative, proceed as follows.

(1) Disconnect and isolate the battery negative cable. Remove the instrument cluster. Connect the battery negative cable. Turn the park lamps on with the headlamp switch. Adjust the panel lamp dimmer switch knob to its highest level (fully upwards). Check for voltage at the panel lamp driver circuit cavity of the instrument cluster wire harness connector. If OK, replace the faulty instrument cluster. If not OK, go to Step 2.

(2) Disconnect and isolate the battery negative cable. Unplug the white 24-way Body Control Module (BCM) wire harness connector. Check for continuity between the panel lamp driver circuit cavities of the instrument cluster wire harness connector and the BCM wire harness connector. If OK, refer to Group 8L - Lamps for diagnosis of the headlamp switch and/or the proper Diagnostic Procedures manual for diagnosis of the BCM. If not OK, repair the open circuit as required.

CRUISE-ON INDICATOR LAMP

The diagnosis found here addresses an inoperative cruise-on indicator lamp condition. If the problem being diagnosed is an inaccurate cruise-on indicator lamp, refer to Group 8H - Vehicle Speed Control for diagnosis of the vehicle speed control system. For circuit descriptions and diagrams, refer to 8W-33 - Vehicle Speed Control and 8W-40 - Instrument Cluster in Group 8W - Wiring Diagrams.

WARNING: ON VEHICLES EQUIPPED WITH AIRBAGS, REFER TO GROUP 8M - PASSIVE RESTRAINT SYSTEMS BEFORE ATTEMPTING ANY STEERING WHEEL, STEERING COLUMN, OR INSTRUMENT PANEL COMPONENT DIAGNOSIS OR SERVICE. FAILURE TO TAKE THE PROPER PRECAUTIONS COULD RESULT IN ACCIDENTAL AIRBAG DEPLOYMENT AND POSSIBLE PERSONAL INJURY.

DIAGNOSIS AND TESTING (Continued)

If the cruise-on indicator lamp fails to light during the bulb test (about four seconds after the ignition switch is turned to the On position), replace the cruise-on indicator lamp bulb with a known good unit. If the cruise-on lamp still fails to operate, diagnosis of the lamp, the instrument cluster circuitry, the vehicle speed control switches, the Powertrain Control Module (PCM) and the CCD data bus should be performed with a DRB scan tool as described in the proper Diagnostic Procedures manual. For further diagnosis of the cruise-on indicator lamp and the instrument cluster circuitry, see Instrument Cluster in this group.

GRAPHIC DISPLAY MODULE

If the problem being diagnosed is related to Graphic Display Module (GDM) illumination, see the GDM Illumination diagnosis below. If the problem being diagnosed is related to the four-wheel drive display or the four-wheel drive message lamps, see the Four-Wheel Drive Indicator Lamp diagnosis below. Refer to 8W-46 - Message Center in Group 8W - Wiring Diagrams for complete circuit descriptions and diagrams.

GDM ILLUMINATION

The diagnosis found here addresses an inoperative graphic display module illumination lamp condition. If the problem being diagnosed is related to the dimming level of the illumination lamps, diagnosis should be performed with a DRB scan tool as described in the proper Diagnostic Procedures manual.

WARNING: ON VEHICLES EQUIPPED WITH AIRBAGS, REFER TO GROUP 8M - PASSIVE RESTRAINT SYSTEMS BEFORE ATTEMPTING ANY STEERING WHEEL, STEERING COLUMN, OR INSTRUMENT PANEL COMPONENT DIAGNOSIS OR SERVICE. FAILURE TO TAKE THE PROPER PRECAUTIONS COULD RESULT IN ACCIDENTAL AIRBAG DEPLOYMENT AND POSSIBLE PERSONAL INJURY.

If only individual illumination lamps are inoperative, replace the faulty bulbs. If all of the illumination lamps are inoperative, proceed as follows.

(1) Disconnect and isolate the battery negative cable. Remove the GDM from the instrument panel. Unplug the GDM wire harness connector. Connect the battery negative cable.

(2) Turn the park lamps on with the headlamp switch. Adjust the panel lamp dimmer switch knob to its highest level (fully upwards). Check for voltage at the panel lamp driver circuit cavity of the GDM wire harness connector. If OK, replace the faulty GDM. If not OK, go to Step 3.

(3) Disconnect and isolate the battery negative cable. Unplug the white 24-way Body Control Module (BCM) wire harness connector. Check for continuity between the panel lamp driver circuit cavities of the GDM wire harness connector and the BCM wire harness connector. If OK, refer to Group 8L - Lamps for diagnosis of the headlamp switch and/or the proper Diagnostic Procedures manual for diagnosis of the BCM. If not OK, repair the open circuit as required.

FOUR-WHEEL DRIVE INDICATOR LAMP

WARNING: ON VEHICLES EQUIPPED WITH AIRBAGS, REFER TO GROUP 8M - PASSIVE RESTRAINT SYSTEMS BEFORE ATTEMPTING ANY STEERING WHEEL, STEERING COLUMN, OR INSTRUMENT PANEL COMPONENT DIAGNOSIS OR SERVICE. FAILURE TO TAKE THE PROPER PRECAUTIONS COULD RESULT IN ACCIDENTAL AIRBAG DEPLOYMENT AND POSSIBLE PERSONAL INJURY.

(1) Unplug the wire harness connector at the transfer case switch. Check for continuity between the ground circuit cavity of the transfer case switch wire harness connector and a good ground. There should be continuity. If OK, go to Step 2. If not OK, repair the open circuit as required.

(2) Check the transfer case switch continuity while shifting the transfer case shift lever to the proper positions. The switch continuity should be as shown in (Fig. 2). If OK, go to Step 3. If not OK, replace the faulty switch.

(3) Disconnect and isolate the battery negative cable. Remove the GDM from the instrument panel. Unplug the GDM wire harness connector.

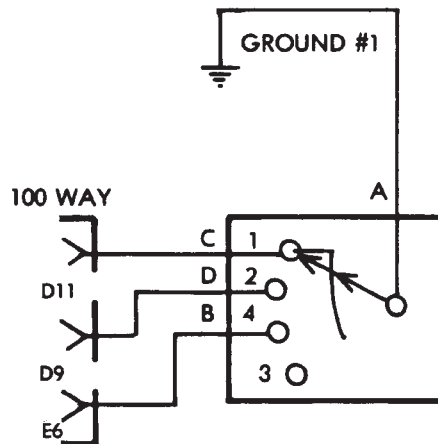
(4) Check for continuity in the circuit for the indicator lamp or wheel lamp that is not functioning between the GDM wire harness connector and the transfer case switch wire harness connector. There should be continuity. If OK, go to Step 5. If not OK, repair the open circuit as required.

(5) Replace the bulb for the inoperative indicator lamp or wheel lamp. Plug in the GDM and transfer case wire harness connectors. Connect the battery negative cable and check the operation of the inoperative lamp. If OK, discard the faulty bulb. If not OK, replace the faulty GDM.

HEADLAMP HIGH BEAM INDICATOR LAMP

The diagnosis found here addresses an inoperative headlamp high beam indicator lamp condition. If the problem being diagnosed is related to inoperative headlamp high beams, refer to Group 8L - Lamps for diagnosis of the headlamp system. If no headlamp system problems are found, proceed as follows. For circuit descriptions and diagrams, refer to 8W-40 - Instrument Cluster in Group 8W - Wiring Diagrams.

DIAGNOSIS AND TESTING (Continued)



231 TRANSFER CASE (COMMAND-TRAC)

T/C POSITION	SWITCH POSITION
2WD	1
4 PART TIME	2
N	3
4 LO	2

242 TRANSFER CASE (SELEC-TRAC)

T/C POSITION	SWITCH POSITION
2WD	1
4 PART TIME	2
4 FULL TIME	4
N	3
4 LO	2

249 TRANSFER CASE (QUADRA-TRAC)

T/C POSITION	SWITCH POSITION
4 ALL TIME	1
N	3
4 LO	2

J948E-63

Fig. 2 Transfer Case Switch

WARNING: ON VEHICLES EQUIPPED WITH AIRBAGS, REFER TO GROUP 8M - PASSIVE RESTRAINT SYSTEMS BEFORE ATTEMPTING ANY STEERING WHEEL, STEERING COLUMN, OR INSTRUMENT PANEL COMPONENT DIAGNOSIS OR SERVICE. FAILURE TO TAKE THE PROPER PRECAUTIONS COULD RESULT IN ACCIDENTAL AIRBAG DEPLOYMENT AND POSSIBLE PERSONAL INJURY.

If the headlamp high beam indicator lamp fails to light during the bulb test (about four seconds after the ignition switch is turned to the On position), replace the headlamp high beam indicator lamp bulb with a known good unit. If the indicator lamp still fails to operate, diagnosis of the lamp, the instrument cluster circuitry, the Chrysler Collision Detection (CCD) data bus, or the Body Control Module (BCM) should be performed with a DRB scan tool as described in the proper Diagnostic Procedures manual. For further diagnosis of the headlamp high beam indicator lamp and the instrument cluster circuitry, see Instrument Cluster in this group.

LOW FUEL WARNING LAMP

The diagnosis found here addresses an inoperative low fuel warning lamp condition. If the problem being diagnosed is related to lamp accuracy, be cer-

tain to confirm the problem is the with the low fuel warning lamp and not with the fuel gauge circuit. See the diagnosis for the Fuel Gauge in this group. If no fuel gauge problem is found, the following procedure will help to identify a faulty low fuel warning lamp circuit. For circuit descriptions and diagrams, refer to 8W-40 - Instrument Cluster in Group 8W - Wiring Diagrams.

WARNING: ON VEHICLES EQUIPPED WITH AIRBAGS, REFER TO GROUP 8M - PASSIVE RESTRAINT SYSTEMS BEFORE ATTEMPTING ANY STEERING WHEEL, STEERING COLUMN, OR INSTRUMENT PANEL COMPONENT DIAGNOSIS OR SERVICE. FAILURE TO TAKE THE PROPER PRECAUTIONS COULD RESULT IN ACCIDENTAL AIRBAG DEPLOYMENT AND POSSIBLE PERSONAL INJURY.

If the low fuel warning lamp fails to light during the bulb test (about four seconds after the ignition switch is turned to the On position), replace the low fuel warning lamp bulb with a known good unit. If the indicator lamp still fails to operate, diagnosis of the lamp, the instrument cluster circuitry, the fuel gauge sending unit and circuit, the Powertrain Control Module (PCM), the Chrysler Collision Detection (CCD) data bus, or the Body Control Module (BCM)

DIAGNOSIS AND TESTING (Continued)

should be performed with a DRB scan tool as described in the proper Diagnostic Procedures manual. For further diagnosis of the low fuel warning lamp and the instrument cluster circuitry, see Instrument Cluster in this group.

MALFUNCTION INDICATOR LAMP

The diagnosis found here addresses an inoperative malfunction indicator (Check Engine) lamp condition. If the lamp comes on and stays on with the engine running, refer to Group 14 - Fuel Systems for diagnosis. For circuit descriptions and diagrams, refer to 8W-40 - Instrument Cluster in Group 8W - Wiring Diagrams.

WARNING: ON VEHICLES EQUIPPED WITH AIRBAGS, REFER TO GROUP 8M - PASSIVE RESTRAINT SYSTEMS BEFORE ATTEMPTING ANY STEERING WHEEL, STEERING COLUMN, OR INSTRUMENT PANEL COMPONENT DIAGNOSIS OR SERVICE. FAILURE TO TAKE THE PROPER PRECAUTIONS COULD RESULT IN ACCIDENTAL AIRBAG DEPLOYMENT AND POSSIBLE PERSONAL INJURY.

If the malfunction indicator lamp fails to light during the bulb test (about three seconds after the ignition switch is turned to the On position), replace the malfunction indicator lamp bulb with a known good unit. If the indicator lamp still fails to operate, diagnosis of the lamp, the instrument cluster circuitry, the Powertrain Control Module (PCM) or the Chrysler Collision Detection (CCD) data bus should be performed with a DRB scan tool as described in the proper Diagnostic Procedures manual. For further diagnosis of the malfunction indicator lamp and the instrument cluster circuitry, see Instrument Cluster in this group.

POWER OUTLET

For circuit descriptions and diagrams, refer to 8W-41 - Horns/Cigar Lighter in Group 8W - Wiring Diagrams.

WARNING: ON VEHICLES EQUIPPED WITH AIRBAGS, REFER TO GROUP 8M - PASSIVE RESTRAINT SYSTEMS BEFORE ATTEMPTING ANY STEERING WHEEL, STEERING COLUMN, OR INSTRUMENT PANEL COMPONENT DIAGNOSIS OR SERVICE. FAILURE TO TAKE THE PROPER PRECAUTIONS COULD RESULT IN ACCIDENTAL AIRBAG DEPLOYMENT AND POSSIBLE PERSONAL INJURY.

(1) Check the fuse in the junction block. If OK, go to Step 2. If not OK, repair the shorted circuit or component as required and replace the faulty fuse.

(2) Check for continuity between the inside circumference of the power outlet receptacle and a good

ground. There should be continuity. If OK, go to Step 3. If not OK, go to Step 4.

(3) Check for battery voltage at the insulated contact located at the back of the power outlet receptacle. If not OK, go to Step 4.

(4) Disconnect and isolate the battery negative cable. Remove the instrument panel center bezel. Check for continuity between the ground circuit cavity of the power outlet wire harness connector and a good ground. There should be continuity. If OK, go to Step 5. If not OK, repair the open circuit to ground as required.

(5) Connect the battery negative cable. Check for battery voltage at the fused B(+) circuit cavity of the power outlet wire harness connector. If OK, replace the faulty cigar lighter receptacle unit. If not OK, repair the open circuit to the junction block fuse as required.

SEAT BELT REMINDER LAMP

The diagnosis found here addresses an inoperative seat belt reminder lamp condition. If the lamp comes on and flashes following its display function (for about seven seconds after the ignition switch is turned to the On position), see the diagnosis for the airbag indicator lamp in this group. For circuit descriptions and diagrams, refer to 8W-40 - Instrument Cluster in Group 8W - Wiring Diagrams.

WARNING: ON VEHICLES EQUIPPED WITH AIRBAGS, REFER TO GROUP 8M - PASSIVE RESTRAINT SYSTEMS BEFORE ATTEMPTING ANY STEERING WHEEL, STEERING COLUMN, OR INSTRUMENT PANEL COMPONENT DIAGNOSIS OR SERVICE. FAILURE TO TAKE THE PROPER PRECAUTIONS COULD RESULT IN ACCIDENTAL AIRBAG DEPLOYMENT AND POSSIBLE PERSONAL INJURY.

If the seat belt reminder lamp fails to light during its display function, replace the seat belt reminder lamp bulb with a known good unit. If the reminder lamp still fails to operate, diagnosis of the lamp and the instrument cluster circuitry should be performed with a DRB scan tool as described in the proper Diagnostic Procedures manual. For further diagnosis of the seat belt indicator lamp and the instrument cluster circuitry, see Instrument Cluster in this group.

TURN SIGNAL INDICATOR LAMP

The diagnosis found here addresses an inoperative turn signal indicator lamp condition. For any other turn signal problem, refer to Group 8J - Turn Signal and Hazard Warning Systems for diagnosis. If no turn signal or hazard warning system problem is found, the following procedure will help locate a short or open in the indicator lamp circuit. For cir-

DIAGNOSIS AND TESTING (Continued)

cuit descriptions and diagrams, refer to 8W-40 - Instrument Cluster and 8W-50 - Front Lighting in Group 8W - Wiring Diagrams.

WARNING: ON VEHICLES EQUIPPED WITH AIRBAGS, REFER TO GROUP 8M - PASSIVE RESTRAINT SYSTEMS BEFORE ATTEMPTING ANY STEERING WHEEL, STEERING COLUMN, OR INSTRUMENT PANEL COMPONENT DIAGNOSIS OR SERVICE. FAILURE TO TAKE THE PROPER PRECAUTIONS COULD RESULT IN ACCIDENTAL AIRBAG DEPLOYMENT AND POSSIBLE PERSONAL INJURY.

(1) Disconnect and isolate the battery negative cable. Remove the instrument cluster.

(2) Connect the battery negative cable. Activate the hazard warning system by depressing the hazard warning switch button to the On position. Check for battery voltage at the inoperative (right or left) turn signal indicator lamp circuit cavity of the instrument cluster wire harness connector. There should be a switching (on and off) battery voltage signal. If OK, replace the faulty (right or left) indicator lamp bulb. If not OK, repair the open circuit to the turn signal/hazard warning (multi-function) switch as required.

VEHICLE INFORMATION CENTER

The Vehicle Information Center (VIC) has a number of display functions and features. The diagnosis found here addresses only those VIC messages and functions that are controlled by hard-wired inputs. To diagnose any internally controlled VIC function or feature, or any that are enabled by inputs on the Chrysler Collision Detection (CCD) data bus network, use a DRB scan tool and the proper Diagnostic Procedures manual. Refer to 8W-46 - Message Center in Group 8W - Wiring Diagrams for complete circuit descriptions and diagrams.

COOLANT LEVEL LOW/COOLANT SENSOR BAD

If the problem being diagnosed is related to message accuracy, be certain to confirm that the problem is with the VIC display and sensor and not with the engine coolant level. The actual engine coolant level should be checked before you proceed with lamp and sensor diagnosis. Refer to 8W-46 - Message Center in Group 8W - Wiring Diagrams for complete circuit descriptions and diagrams.

WARNING: ON VEHICLES EQUIPPED WITH AIRBAGS, REFER TO GROUP 8M - PASSIVE RESTRAINT SYSTEMS BEFORE ATTEMPTING ANY STEERING WHEEL, STEERING COLUMN, OR INSTRUMENT PANEL COMPONENT DIAGNOSIS OR SERVICE. FAILURE TO TAKE THE PROPER PRECAUTIONS COULD RESULT IN

ACCIDENTAL AIRBAG DEPLOYMENT AND POSSIBLE PERSONAL INJURY.

(1) Unplug the coolant level sensor wire harness connector from the coolant sensor located on the coolant reserve bottle. Check for continuity between the ground circuit cavity of the coolant level sensor wire harness connector and a good ground. There should be continuity. If OK, go to Step 2. If not OK, repair the open circuit as required.

(2) With the engine coolant at the proper level, check the resistance between the two terminals of the coolant level sensor. The resistance should be 3000 to 3500 ohms. If OK, go to Step 3. If not OK, replace the faulty sensor.

(3) Disconnect and isolate the battery negative cable. Remove the VIC module from the instrument panel. Unplug the VIC module wire harness connector. Check for continuity between the engine coolant level switch sense circuit cavity of the VIC wire harness connector and a good ground. There should be no continuity. If OK, go to Step 4. If not OK, repair the short circuit as required.

(4) Check for continuity between the engine coolant level switch sense circuit cavities of the VIC wire harness connector and the engine coolant level sensor wire harness connector. If OK, replace the faulty VIC module. If not OK, repair the open circuit as required.

FOUR-WHEEL DRIVE DISPLAY AND INDICATORS/SERVICE 4WD SWITCH

If the problem being diagnosed is related to an incorrect or no four-wheel drive display or indicator functions, be certain to confirm that the problem is with the VIC module and transfer case switch circuits, and not with a Powertrain Control Module (PCM) with an incorrect Vehicle Identification Number (VIN). This condition can only occur if the original PCM was replaced with a unit from another vehicle. The VIC module uses the VIN message received on the Chrysler Collision Detection (CCD) data bus from the PCM to determine if the vehicle is equipped with two-wheel drive or four-wheel drive.

If a four-wheel drive vehicle has a two-wheel drive VIN entered in the PCM, the VIC will ignore all transfer case switch inputs. If a two-wheel drive vehicle has a four-wheel drive VIN entered in the PCM, the rear wheels in the VIC display will not light. Use a DRB scan tool and the proper Diagnostic Procedures manual to confirm the VIN stored in the PCM.

In addition, it should be noted that a VIC "Service 4WD Switch" message on a two-wheel drive vehicle can occur if a short circuit occurs in the transfer case switch circuits from the VIC module, in combination with a PCM having a four-wheel drive VIN. To locate

DIAGNOSIS AND TESTING (Continued)

the short circuit, start at Step 3 of the following diagnostic procedure. Two-wheel drive models do have the same VIC wire harness provisions as four-wheel drive models.

WARNING: ON VEHICLES EQUIPPED WITH AIRBAGS, REFER TO GROUP 8M - PASSIVE RESTRAINT SYSTEMS BEFORE ATTEMPTING ANY STEERING WHEEL, STEERING COLUMN, OR INSTRUMENT PANEL COMPONENT DIAGNOSIS OR SERVICE. FAILURE TO TAKE THE PROPER PRECAUTIONS COULD RESULT IN ACCIDENTAL AIRBAG DEPLOYMENT AND POSSIBLE PERSONAL INJURY.

(1) Unplug the wire harness connector at the transfer case switch. Check for continuity between the ground circuit cavity of the transfer case switch wire harness connector and a good ground. There should be continuity. If OK, go to Step 2. If not OK, repair the open circuit as required.

(2) Check the transfer case switch continuity while shifting the transfer case shift lever to the various positions. The switch continuity should be as shown in (Fig. 3). If OK, go to Step 3. If not OK, replace the faulty switch.

(3) Disconnect and isolate the battery negative cable. Remove the VIC module from the instrument

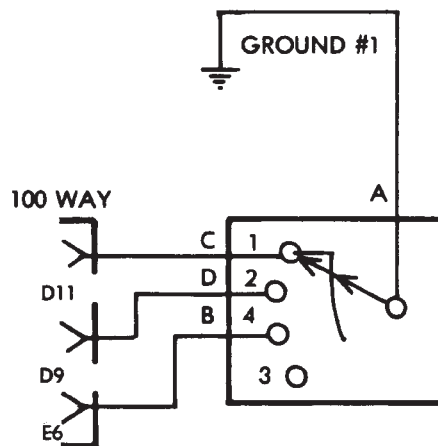
panel. Unplug the VIC module wire harness connector.

(4) Locate two pairs of wire harness connectors located in the wire harness leading to the VIC module. The wire harness connectors should be taped back to the harness. One pair of connectors are black with a single cavity. The other pair are red with two cavities. If the vehicle has the Quadra-Trac 4WD transfer case, only the red wire harness connectors should be joined. If the vehicle has the Command-Trac or Selec-Trac 4WD transfer case, only the black wire harness connectors should be joined. In all cases, only one pair of wire harness connectors should be joined. If OK, go to Step 5. If not OK, correct the wire harness connections as required.

(5) Refer to the VIC 4WD Display Characteristics chart (Fig. 4). Check the continuity of the circuit for the indicator lamp or wheel lamp that is not functioning between the VIC module wire harness connector and the transfer case switch wire harness connector. There should be continuity. If OK, replace the faulty VIC module. If not OK, repair the open circuit as required.

REAR LAMP FAILURE

Refer to the diagnosis for the lamp outage module in Group 8L - Lamps to diagnose this feature of the



231 TRANSFER CASE (COMMAND-TRAC)

T/C POSITION	SWITCH POSITION
2WD	1
4 PART TIME	2
N	3
4 LO	2

242 TRANSFER CASE (SELEC-TRAC)

T/C POSITION	SWITCH POSITION
2WD	1
4 PART TIME	2
4 FULL TIME	4
N	3
4 LO	2

249 TRANSFER CASE (QUADRA-TRAC)

T/C POSITION	SWITCH POSITION
4 ALL TIME	1
N	3
4 LO	2

Fig. 3 Transfer Case Switch

DIAGNOSIS AND TESTING (Continued)

DRIVE SYSTEM (TRANSFER CASE)	VIC 4WD DISPLAY CHARACTERISTICS	TRANSFER CASE SHIFT LEVER POSITION				
		2WD	4 PART TIME	4 FULL/ALL TIME	NEUTRAL	4 LO
4WD QUADRA-TRAC (NP249)	Nomenclature	N/A	N/A	None	None	"LO"
	Lighted Wheels	N/A	N/A	All	None	All
4WD SELEC-TRAC (NP242)	Nomenclature	None	"PART TIME"	"FULL TIME"	None	"PART TIME"
	Lighted Wheels	Rear	All	All	None	All
4WD COMMAND-TRAC (NP231)	Nomenclature	None	"PART TIME"	N/A	None	"PART TIME"
	Lighted Wheels	Rear	All	N/A	None	All
2WD (NONE)	Nomenclature	None	N/A	N/A	N/A	N/A
	Lighted Wheels	None	N/A	N/A	N/A	N/A

N/A=Not Applicable

J958E-42

Fig. 4 VIC 4WD Display Characteristics

VIC module. Refer to 8W-46 - Message Center in Group 8W - Wiring Diagrams for complete circuit descriptions and diagrams.

TURN SIGNAL ON

Refer to Group 8J - Turn Signal and Hazard Warning Systems for more information on this feature of the VIC module. The VIC module uses its internal programming, and inputs from the combination flasher on the fused ignition switch output (L5) circuit, and a vehicle speed sensor (distance) message received on the Chrysler Collision Detection (CCD) data bus from the Powertrain Control Module (PCM) to control this message.

If testing of the L5 circuit between the VIC module wire harness connector and the combination flasher cavity in the junction block reveals no problem, use a DRB scan tool and the proper Diagnostic Procedures manual to diagnose the VIC module and the CCD data bus. Refer to 8W-46 - Message Center in Group 8W - Wiring Diagrams for complete circuit descriptions and diagrams.

WASHER LEVEL LOW/WASHER SENSOR BAD

If the problem being diagnosed is related to message accuracy, be certain to confirm that the problem is with the VIC display and sensor and not with the washer fluid level. The actual fluid level should be checked before you proceed with lamp and sensor diagnosis. Refer to 8W-46 - Message Center in Group 8W - Wiring Diagrams for complete circuit descriptions and diagrams.

WARNING: ON VEHICLES EQUIPPED WITH AIRBAGS, REFER TO GROUP 8M - PASSIVE RESTRAINT SYSTEMS BEFORE ATTEMPTING ANY STEERING WHEEL, STEERING COLUMN, OR INSTRUMENT PANEL COMPONENT DIAGNOSIS OR SERVICE. FAILURE TO TAKE THE PROPER PRECAUTIONS COULD RESULT IN ACCIDENTAL AIRBAG DEPLOYMENT AND POSSIBLE PERSONAL INJURY.

(1) Unplug the washer fluid level sensor wire harness connector from the sensor located on the washer

reservoir bottle. Check for continuity between the ground circuit cavity of the washer fluid level sensor wire harness connector and a good ground. There should be continuity. If OK, go to Step 2. If not OK, repair the open circuit as required.

(2) With the washer fluid at the proper level, check the resistance between the two terminals of the washer fluid level sensor. The resistance should be 3000 to 3500 ohms. If OK, go to Step 3. If not OK, replace the faulty sensor.

(3) Disconnect and isolate the battery negative cable. Remove the VIC module from the instrument panel. Unplug the VIC module wire harness connector. Check for continuity between the washer fluid level sense circuit cavity of the VIC module wire harness connector and a good ground. There should be no continuity. If OK, go to Step 4. If not OK, repair the short circuit as required.

(4) Check for continuity between the washer fluid level sense circuit cavities of the VIC module wire harness connector and the washer fluid level sensor wire harness connector. If OK, replace the faulty VIC module. If not OK, repair the open circuit as required.

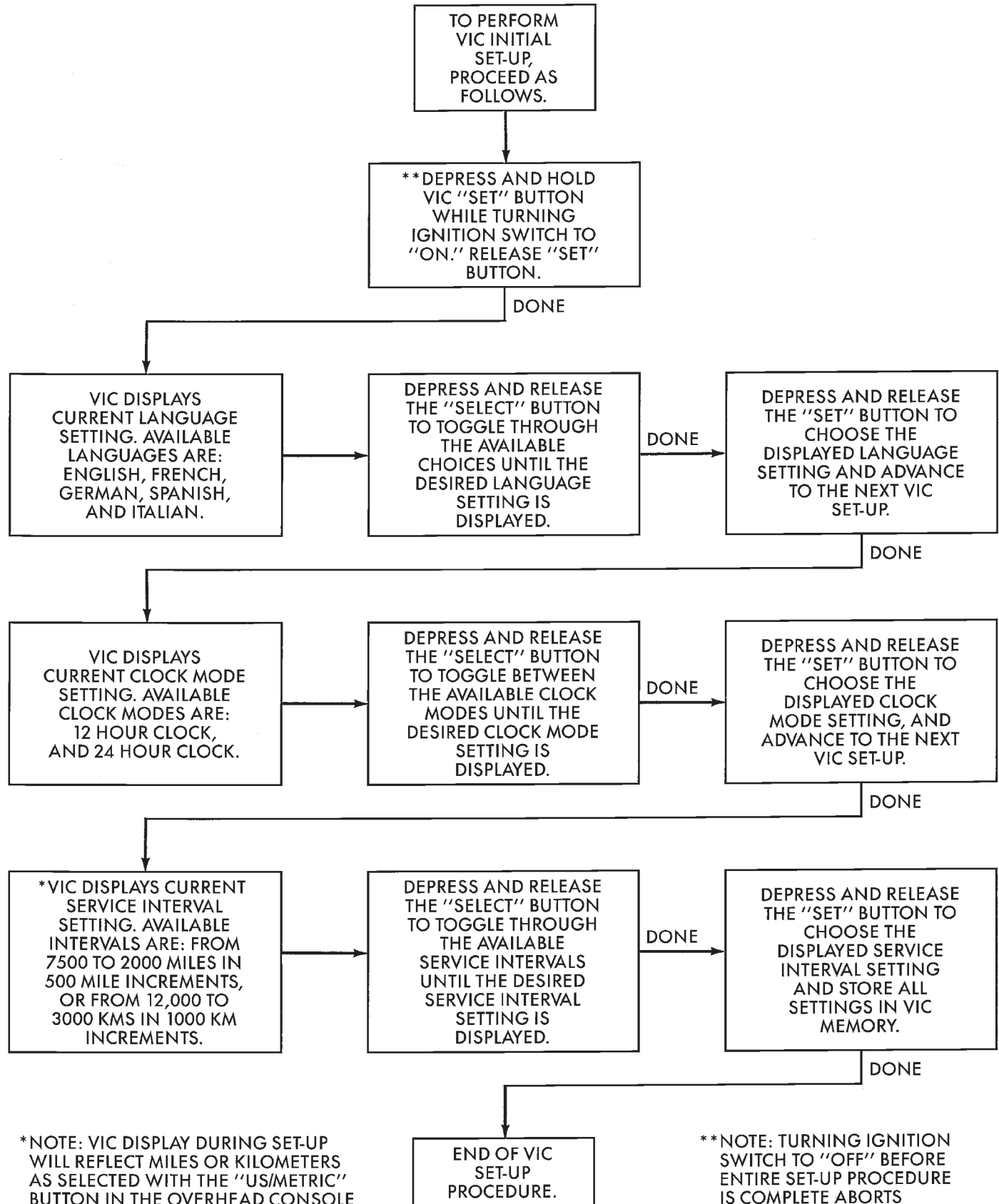
SERVICE PROCEDURES

VEHICLE INFORMATION CENTER

The following flow charts describe the procedures to perform an initial setup of the Vehicle Information Center (VIC), and how to reset the VIC service reminder or time/date settings.

If the vehicle is equipped with a Chrysler radio that is connected to the Chrysler Collision Detection (CCD) data bus network, the hour and minute settings of the VIC clock will automatically be synchronized to the hour and minute settings of the radio clock. This is done by a message that the radio sends to the VIC module on the CCD data bus. Also, the VIC module will automatically suppress the VIC hour and minute set functions if there is a Chrysler radio connected to the CCD data bus, and the VIC clock must be set through the radio clock. Refer to Group 8F - Audio Systems for more information on this feature.

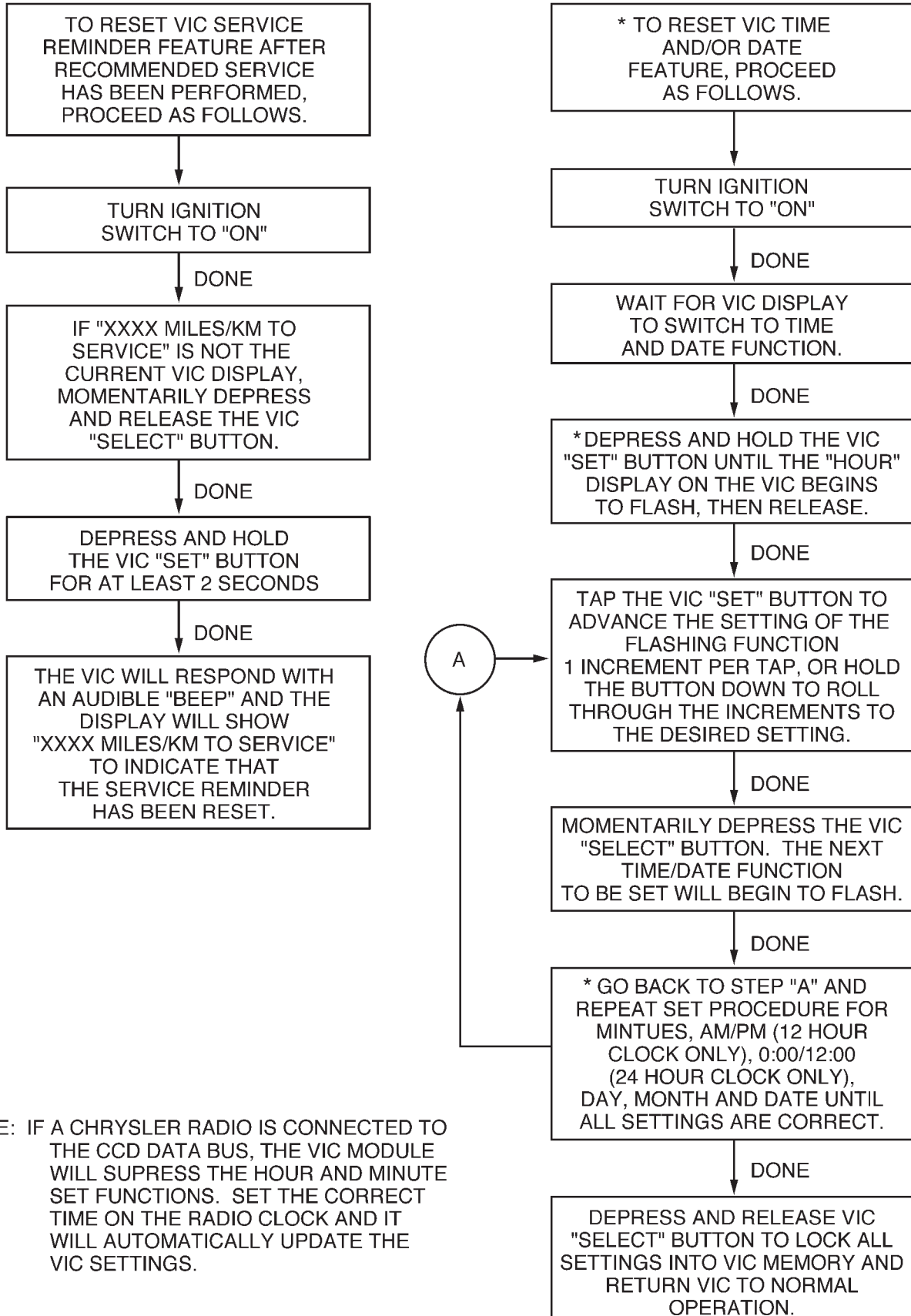
SERVICE PROCEDURES (Continued)



*NOTE: VIC DISPLAY DURING SET-UP WILL REFLECT MILES OR KILOMETERS AS SELECTED WITH THE "US/METRIC" BUTTON IN THE OVERHEAD CONSOLE BEFORE THE SET-UP PROCEDURE WAS BEGUN.

**NOTE: TURNING IGNITION SWITCH TO "OFF" BEFORE ENTIRE SET-UP PROCEDURE IS COMPLETE ABORTS VIC SET-UP AND NOTHING IS SAVED.

SERVICE PROCEDURES (Continued)



*NOTE: IF A CHRYSLER RADIO IS CONNECTED TO THE CCD DATA BUS, THE VIC MODULE WILL SUPPRESS THE HOUR AND MINUTE SET FUNCTIONS. SET THE CORRECT TIME ON THE RADIO CLOCK AND IT WILL AUTOMATICALLY UPDATE THE VIC SETTINGS.

REMOVAL AND INSTALLATION

SWITCH POD BEZEL

WARNING: ON VEHICLES EQUIPPED WITH AIRBAGS, REFER TO GROUP 8M - PASSIVE RESTRAINT SYSTEMS BEFORE ATTEMPTING ANY STEERING WHEEL, STEERING COLUMN, OR INSTRUMENT PANEL COMPONENT DIAGNOSIS OR SERVICE. FAILURE TO TAKE THE PROPER PRECAUTIONS COULD RESULT IN ACCIDENTAL AIRBAG DEPLOYMENT AND POSSIBLE PERSONAL INJURY.

(1) Both switch pod bezels are secured to the instrument panel with snap clip retainers and a light snap fit. Using a trim stick or another suitable wide flat-bladed tool, gently pry around the perimeter edges of the bezel to release the snap clip retainers.

(2) Remove the bezel from the instrument panel.

(3) To install the bezel, use one hand to hold it in position on the instrument panel, then use the other hand to push the bezel towards the instrument panel until each of the retainers snaps firmly into place.

STEERING COLUMN OPENING COVER AND KNEE BLOCKER

WARNING: ON VEHICLES EQUIPPED WITH AIRBAGS, REFER TO GROUP 8M - PASSIVE RESTRAINT SYSTEMS BEFORE ATTEMPTING ANY STEERING WHEEL, STEERING COLUMN, OR INSTRUMENT PANEL COMPONENT DIAGNOSIS OR SERVICE. FAILURE TO TAKE THE PROPER PRECAUTIONS COULD RESULT IN ACCIDENTAL AIRBAG DEPLOYMENT AND POSSIBLE PERSONAL INJURY.

(1) Disconnect and isolate the battery negative cable.

(2) Remove both switch pod bezels. See Switch Pod Bezel in this group for the procedures.

(3) Remove the one screw on each side of the steering column that secures the upper edge of the steering column opening cover/knee blocker to the instrument panel (Fig. 5).

(4) Remove the one screw that secures the steering column opening cover/knee blocker to the outboard end of instrument panel.

(5) Remove the four screws that secure the lower edge of the steering column opening cover/knee blocker to the lower instrument panel reinforcement.

(6) Using a trim stick or another suitable wide flat-bladed tool, gently pry the edges of the steering column opening cover/knee blocker away from the instrument panel at the snap clip retainer locations (Fig. 5).

(7) Remove the steering column opening cover/knee blocker from the instrument panel.

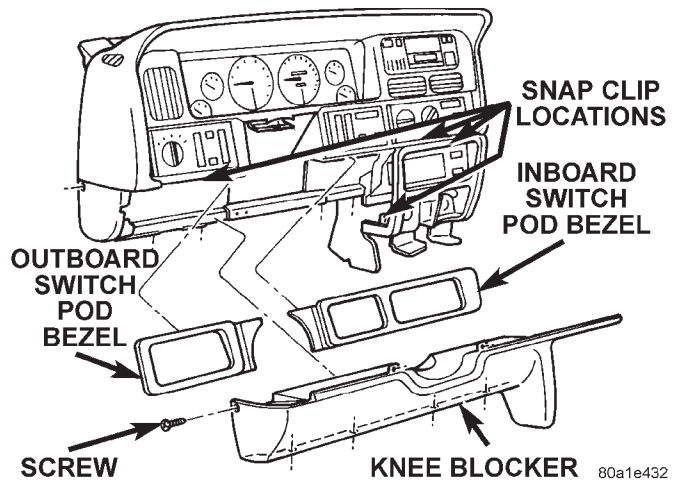


Fig. 5 Steering Column Opening Cover/Knee Blocker Remove/Install

(8) Reverse the removal procedures to install. Tighten the mounting screws to 2.2 N·m (20 in. lbs.).

CLUSTER BEZEL

WARNING: ON VEHICLES EQUIPPED WITH AIRBAGS, REFER TO GROUP 8M - PASSIVE RESTRAINT SYSTEMS BEFORE ATTEMPTING ANY STEERING WHEEL, STEERING COLUMN, OR INSTRUMENT PANEL COMPONENT DIAGNOSIS OR SERVICE. FAILURE TO TAKE THE PROPER PRECAUTIONS COULD RESULT IN ACCIDENTAL AIRBAG DEPLOYMENT AND POSSIBLE PERSONAL INJURY.

(1) Disconnect and isolate the battery negative cable.

(2) Remove both switch pod bezels from the instrument panel. See Switch Pod Bezel in this group for the procedures.

(3) Remove the ten screws that secure the cluster bezel to the instrument panel (Fig. 6).

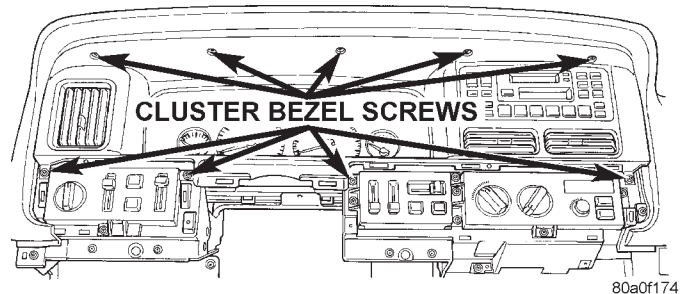


Fig. 6 Cluster Bezel Screws Remove/Install

(4) Pull the cluster bezel rearward and move it to the outboard side of the steering wheel to remove it from the instrument panel.

(5) Reverse the removal procedures to install. Tighten the mounting screws to 2.2 N·m (20 in. lbs.).

REMOVAL AND INSTALLATION (Continued)

INSTRUMENT CLUSTER

WARNING: ON VEHICLES EQUIPPED WITH AIRBAGS, REFER TO GROUP 8M - PASSIVE RESTRAINT SYSTEMS BEFORE ATTEMPTING ANY STEERING WHEEL, STEERING COLUMN, OR INSTRUMENT PANEL COMPONENT DIAGNOSIS OR SERVICE. FAILURE TO TAKE THE PROPER PRECAUTIONS COULD RESULT IN ACCIDENTAL AIRBAG DEPLOYMENT AND POSSIBLE PERSONAL INJURY.

- (1) Remove the cluster bezel from the instrument panel. See Cluster Bezel in this group for the procedures.
- (2) Remove the two screws that secure each end of the instrument cluster to the instrument panel.
- (3) Pull the instrument cluster rearward to disengage the self-docking wire harness connector.

NOTE: The instrument cluster has a self-docking wire harness connector that will be automatically aligned with, and connected to the instrument panel wire harness when the cluster is installed in the instrument panel.

- (4) Remove the instrument cluster from the vehicle.
- (5) Reverse the removal procedures to install. Tighten the mounting screws to 2.2 N-m (20 in. lbs.).

TRIP ODOMETER RESET KNOB

- (1) Grasp the knob firmly between the thumb and forefinger.

- (2) Gently pull the knob away from the instrument cluster until it slides off of the trip odometer reset switch stem.
- (3) Reverse the removal procedures to install.

CLUSTER COMPONENTS

CLUSTER LENS

WARNING: ON VEHICLES EQUIPPED WITH AIRBAGS, REFER TO GROUP 8M - PASSIVE RESTRAINT SYSTEMS BEFORE ATTEMPTING ANY STEERING WHEEL, STEERING COLUMN, OR INSTRUMENT PANEL COMPONENT DIAGNOSIS OR SERVICE. FAILURE TO TAKE THE PROPER PRECAUTIONS COULD RESULT IN ACCIDENTAL AIRBAG DEPLOYMENT AND POSSIBLE PERSONAL INJURY.

- (1) Disconnect and isolate the battery negative cable.
- (2) Remove the trip odometer reset knob from the trip odometer reset switch stem. See Trip Odometer Reset Knob in this group for the procedures.
- (3) Remove the instrument cluster from the instrument panel. See Instrument Cluster in this group for the procedures.
- (4) Work around the perimeter of the cluster depressing the snap clips that secure the cluster lens to the cluster hood, and gently pull the lens away from the cluster (Fig. 7).
- (5) Reverse the removal procedures to install.

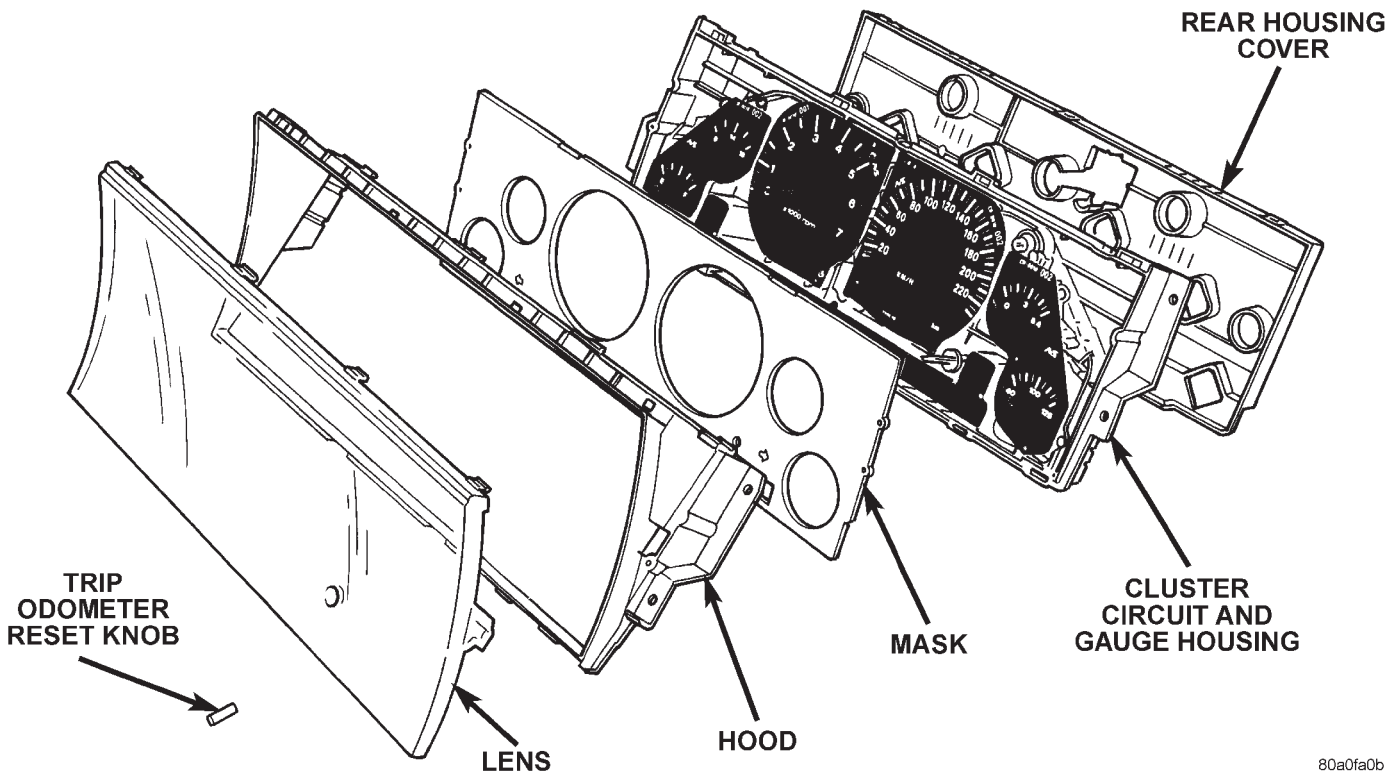


Fig. 7 Instrument Cluster Components

REMOVAL AND INSTALLATION (Continued)**CLUSTER HOOD AND MASK**

WARNING: ON VEHICLES EQUIPPED WITH AIRBAGS, REFER TO GROUP 8M - PASSIVE RESTRAINT SYSTEMS BEFORE ATTEMPTING ANY STEERING WHEEL, STEERING COLUMN, OR INSTRUMENT PANEL COMPONENT DIAGNOSIS OR SERVICE. FAILURE TO TAKE THE PROPER PRECAUTIONS COULD RESULT IN ACCIDENTAL AIRBAG DEPLOYMENT AND POSSIBLE PERSONAL INJURY.

- (1) Disconnect and isolate the battery negative cable.
- (2) Remove the cluster lens from the instrument cluster. See Cluster Lens in this group for the procedures.
- (3) Work around the perimeter of the cluster depressing the snap clips that secure the cluster hood to the cluster housing, and gently pull the hood away from the cluster (Fig. 7).
- (4) Lift the cluster mask off of the locating pins on the front of the cluster housing.
- (5) Reverse the removal procedures to install.

CLUSTER REAR COVER

WARNING: ON VEHICLES EQUIPPED WITH AIRBAGS, REFER TO GROUP 8M - PASSIVE RESTRAINT SYSTEMS BEFORE ATTEMPTING ANY STEERING WHEEL, STEERING COLUMN, OR INSTRUMENT PANEL COMPONENT DIAGNOSIS OR SERVICE. FAILURE TO TAKE THE PROPER PRECAUTIONS COULD RESULT IN

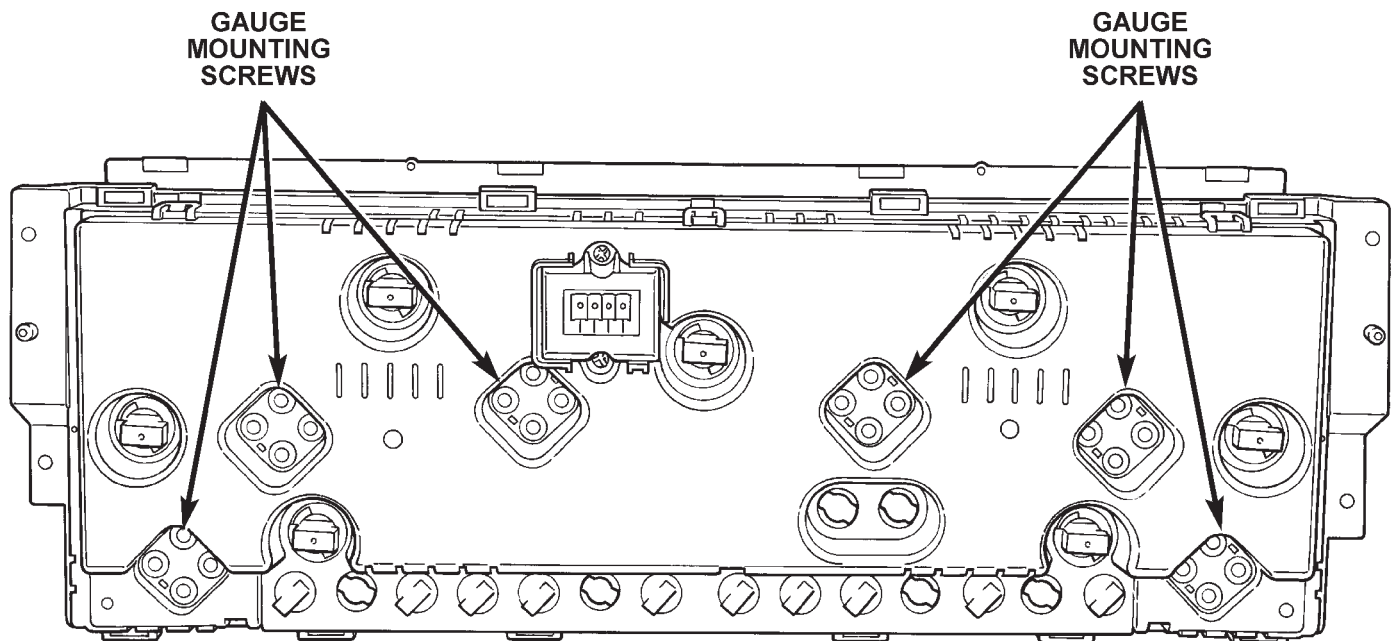
ACCIDENTAL AIRBAG DEPLOYMENT AND POSSIBLE PERSONAL INJURY.

- (1) Disconnect and isolate the battery negative cable.
- (2) Remove the instrument cluster from the instrument panel. See Instrument Cluster in this group for the procedures.
- (3) Work around the perimeter of the cluster releasing the snap clips that secure the rear cover to the back of the cluster housing, and gently pull the rear cover away from the cluster housing (Fig. 7).
- (4) Reverse the removal procedures to install.

GAUGE

WARNING: ON VEHICLES EQUIPPED WITH AIRBAGS, REFER TO GROUP 8M - PASSIVE RESTRAINT SYSTEMS BEFORE ATTEMPTING ANY STEERING WHEEL, STEERING COLUMN, OR INSTRUMENT PANEL COMPONENT DIAGNOSIS OR SERVICE. FAILURE TO TAKE THE PROPER PRECAUTIONS COULD RESULT IN ACCIDENTAL AIRBAG DEPLOYMENT AND POSSIBLE PERSONAL INJURY.

- (1) Remove the cluster hood and mask, and the cluster rear cover from the cluster housing. See Cluster Hood and Mask, and Cluster Rear Cover in this group for the procedures.
- (2) Remove the screws that secure the faulty gauge(s) to the cluster housing from the rear of the cluster electronic circuit board (Fig. 8).



80a0fa0c

Fig. 8 Gauge Mounting Screws

REMOVAL AND INSTALLATION (Continued)

- (3) Remove the faulty gauge(s) from the front of the cluster housing.
- (4) Reverse the removal procedures to install. Tighten the gauge mounting screws to 2.2 N-m (20 in. lbs.).

CLUSTER BULB

WARNING: ON VEHICLES EQUIPPED WITH AIR-BAGS, REFER TO GROUP 8M - PASSIVE RESTRAINT SYSTEMS BEFORE ATTEMPTING ANY STEERING WHEEL, STEERING COLUMN, OR INSTRUMENT PANEL COMPONENT DIAGNOSIS OR SERVICE. FAILURE TO TAKE THE PROPER PRECAUTIONS COULD RESULT IN ACCIDENTAL AIR-BAG DEPLOYMENT AND POSSIBLE PERSONAL INJURY.

- (1) Remove the instrument cluster from the instrument panel. See Instrument Cluster in this group for the procedures.
- (2) Remove the bulb and bulb holder from the circuit board on the rear of the cluster housing by turning the holder counterclockwise (Fig. 9).

CAUTION: Always use the correct bulb size and type for replacement. An incorrect bulb size or type may overheat and cause damage to the instrument cluster printed circuit and/or the gauges.

- (3) Reverse the removal procedures to install.

OUTBOARD SWITCH POD

WARNING: ON VEHICLES EQUIPPED WITH AIR-BAGS, REFER TO GROUP 8M - PASSIVE RESTRAINT SYSTEMS BEFORE ATTEMPTING ANY STEERING WHEEL, STEERING COLUMN, OR INSTRUMENT PANEL COMPONENT DIAGNOSIS OR SERVICE. FAILURE TO TAKE THE PROPER PRECAUTIONS COULD RESULT IN ACCIDENTAL AIR-BAG DEPLOYMENT AND POSSIBLE PERSONAL INJURY.

- (1) Remove the cluster bezel from the instrument panel. See Cluster Bezel in this group for the procedures.
- (2) Remove the two screws that secure the outboard switch pod to the instrument panel (Fig. 10).

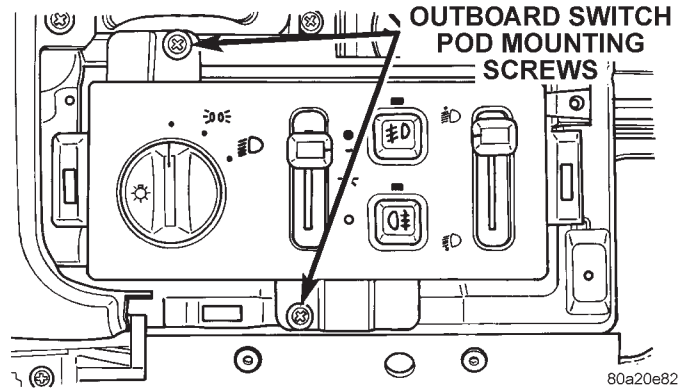


Fig. 10 Outboard Switch Pod Remove/Install

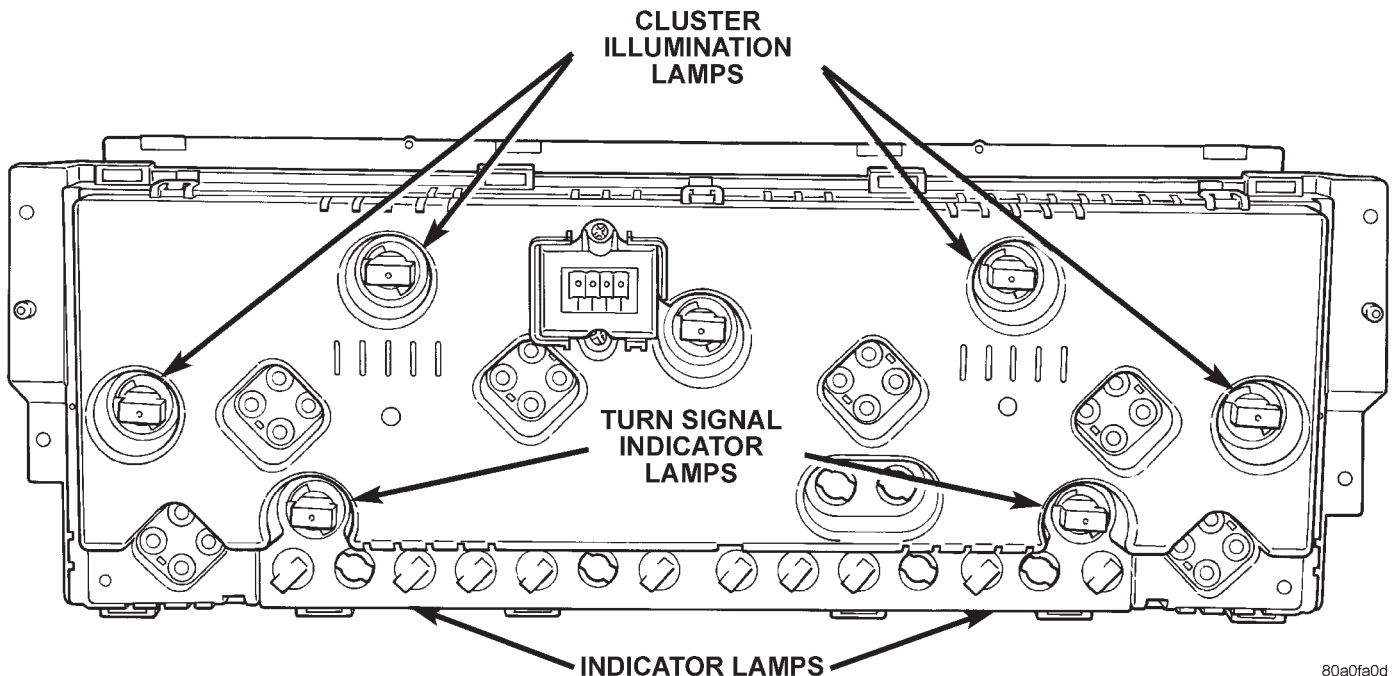


Fig. 9 Cluster Bulb Locations

REMOVAL AND INSTALLATION (Continued)

(3) Pull the outboard switch pod out from the instrument panel far enough to unplug the wire harness connectors.

(4) Remove the outboard switch pod from the instrument panel.

(5) Reverse the removal procedures to install. Tighten the mounting screws to 2.2 N·m (20 in. lbs.).

INBOARD SWITCH POD

WARNING: ON VEHICLES EQUIPPED WITH AIRBAGS, REFER TO GROUP 8M - PASSIVE RESTRAINT SYSTEMS BEFORE ATTEMPTING ANY STEERING WHEEL, STEERING COLUMN, OR INSTRUMENT PANEL COMPONENT DIAGNOSIS OR SERVICE. FAILURE TO TAKE THE PROPER PRECAUTIONS COULD RESULT IN ACCIDENTAL AIRBAG DEPLOYMENT AND POSSIBLE PERSONAL INJURY.

(1) Remove the cluster bezel from the instrument panel. See Cluster Bezel in this group for the procedures.

(2) Remove the two screws that secure the inboard switch pod to the instrument panel (Fig. 11).

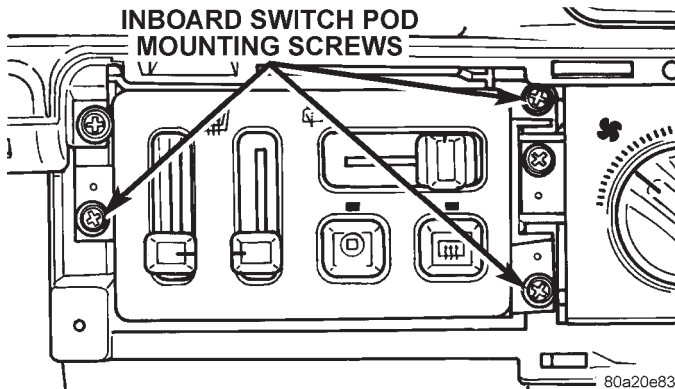


Fig. 11 Inboard Switch Pod Remove/Install

(3) Pull the inboard switch pod out from the instrument panel far enough to unplug the wire harness connectors.

(4) Remove the inboard switch pod from the instrument panel.

(5) Reverse the removal procedures to install. Tighten the mounting screws to 2.2 N·m (20 in. lbs.).

BODY CONTROL MODULE

Before replacing the Body Control Module (BCM), use a DRB scan tool to determine the current settings for the BCM programmable features. These settings should be duplicated in the replacement BCM using the DRB scan tool, before returning the vehicle to service.

WARNING: ON VEHICLES EQUIPPED WITH AIRBAGS, REFER TO GROUP 8M - PASSIVE RESTRAINT SYSTEMS BEFORE ATTEMPTING ANY STEERING WHEEL, STEERING COLUMN, OR INSTRUMENT PANEL COMPONENT DIAGNOSIS OR SERVICE. FAILURE TO TAKE THE PROPER PRECAUTIONS COULD RESULT IN ACCIDENTAL AIRBAG DEPLOYMENT AND POSSIBLE PERSONAL INJURY.

(1) Remove the steering column opening cover/knee blocker from the instrument panel. See Steering Column Opening Cover and Knee Blocker in this group for the procedures.

(2) Remove the four screws located below the outboard switch pod that secure the Body Control Module (BCM) to the instrument panel armature (Fig. 12).

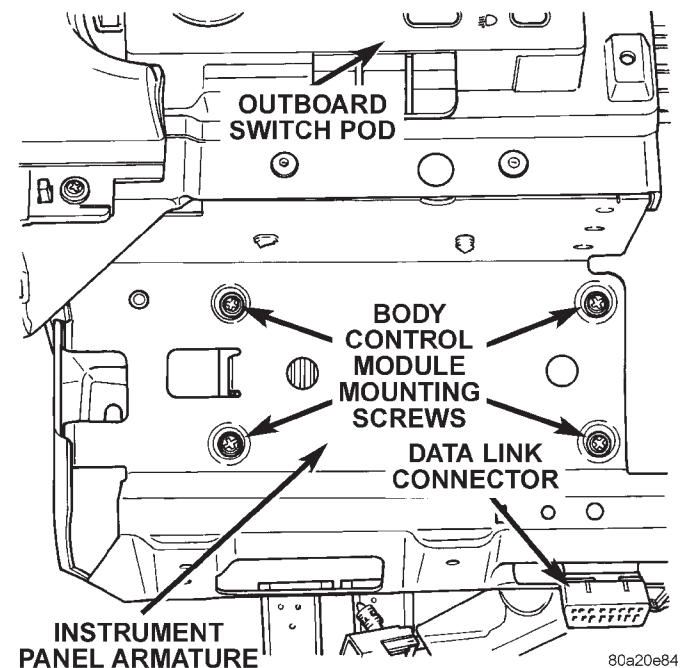


Fig. 12 Body Control Module Remove/Install

(3) Move the BCM towards the steering column far enough to access the three wire harness connectors.

(4) Unplug the wire harness connectors from the BCM.

(5) Remove the BCM from the instrument panel.

(6) Reverse the removal procedures to install. Tighten the mounting screws to 2.2 N·m (20 in. lbs.).

NOTE: If a new Body Control Module is installed, the programmable features must be enabled and/or disabled to the customer's preferred settings. Use a DRB scan tool and the proper Diagnostic Procedures manual to perform these operations.

REMOVAL AND INSTALLATION (Continued)**GLOVE BOX MODULE**

WARNING: ON VEHICLES EQUIPPED WITH AIR-BAGS, REFER TO GROUP 8M - PASSIVE RESTRAINT SYSTEMS BEFORE ATTEMPTING ANY STEERING WHEEL, STEERING COLUMN, OR INSTRUMENT PANEL COMPONENT DIAGNOSIS OR SERVICE. FAILURE TO TAKE THE PROPER PRECAUTIONS COULD RESULT IN ACCIDENTAL AIR-BAG DEPLOYMENT AND POSSIBLE PERSONAL INJURY.

(1) Remove the steering column opening cover/knee blocker from the instrument panel. See Steering Column Opening Cover and Knee Blocker in this group for the procedures.

(2) Remove the two screws that secure the top of the instrument panel center bezel to the instrument panel above the Graphic Display Module (GDM) or Vehicle Information Center (VIC).

(3) Remove the ash receiver from the instrument panel center bezel.

(4) Remove the two screws in the back of the ash receiver opening that secure the instrument panel center bezel to the instrument panel armature.

(5) Remove the screw that secures the courtesy lamp to the lower instrument panel located under the outboard end of the glove box module.

(6) Open the passenger side front door and remove the screw that secures the outboard end of the glove box module to the instrument panel armature.

(7) Remove the four screws that secure the glove box hinge to the instrument panel armature on the lower edge of the glove box module.

(8) Open the glove box door and remove the four screws at the top of the glove box opening that secure the upper edge of the glove box module to the instrument panel armature.

(9) Lower the glove box module far enough to access and unplug the wire harness connectors from the glove box lamp and switch, the cigar lighter and lamp, and the power outlet. Also remove the ash receiver lamp bulb and socket as a unit by gently pulling it out of the ash receiver lamp hood.

(10) Remove the glove box module from the instrument panel.

(11) Reverse the removal procedures to install. Tighten the mounting screws to 2.2 N·m (20 in. lbs.).

GRAPHIC DISPLAY MODULE AND VEHICLE INFORMATION CENTER

WARNING: ON VEHICLES EQUIPPED WITH AIR-BAGS, REFER TO GROUP 8M - PASSIVE RESTRAINT SYSTEMS BEFORE ATTEMPTING ANY STEERING WHEEL, STEERING COLUMN, OR INSTRUMENT PANEL COMPONENT DIAGNOSIS OR

SERVICE. FAILURE TO TAKE THE PROPER PRECAUTIONS COULD RESULT IN ACCIDENTAL AIR-BAG DEPLOYMENT AND POSSIBLE PERSONAL INJURY.

(1) Remove the glove box module from the instrument panel. See Glove Box Module in this group for the procedures.

(2) Remove the three screws that secure the Graphic Display Module (GDM) or Vehicle Information Center (VIC) to the instrument panel armature (Fig. 13).

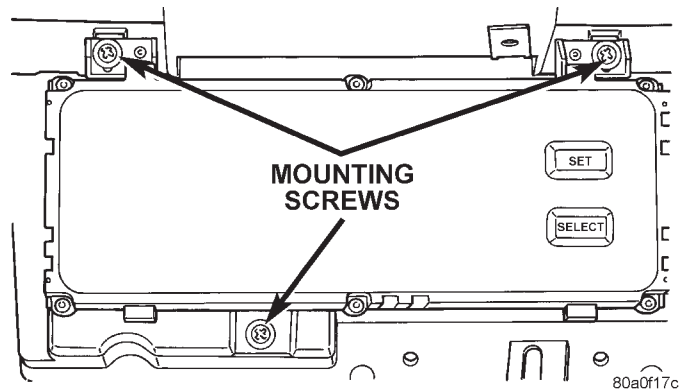


Fig. 13 Graphic Display Module and Vehicle Information Center Remove/Install

(3) Pull the GDM or VIC unit out from the instrument panel far enough to access and unplug the wire harness connector.

(4) Remove the GDM or VIC from the instrument panel.

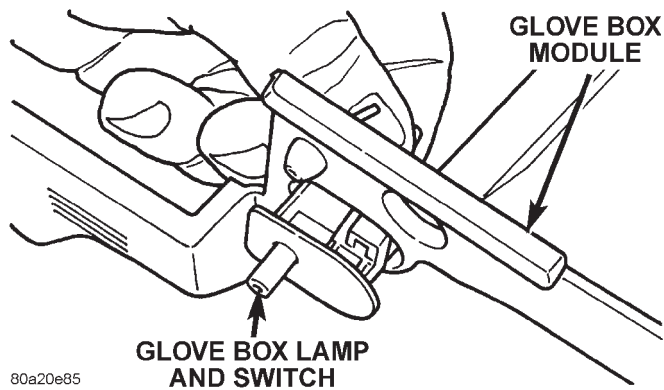
(5) Reverse the removal procedures to install. Tighten the mounting screws to 2.2 N·m (20 in. lbs.).

GLOVE BOX LAMP AND SWITCH

WARNING: ON VEHICLES EQUIPPED WITH AIR-BAGS, REFER TO GROUP 8M - PASSIVE RESTRAINT SYSTEMS BEFORE ATTEMPTING ANY STEERING WHEEL, STEERING COLUMN, OR INSTRUMENT PANEL COMPONENT DIAGNOSIS OR SERVICE. FAILURE TO TAKE THE PROPER PRECAUTIONS COULD RESULT IN ACCIDENTAL AIR-BAG DEPLOYMENT AND POSSIBLE PERSONAL INJURY.

(1) Remove the glove box module from the instrument panel. See Glove Box Module in this group for the procedures.

(2) From the back side of the glove box module, squeeze the retaining tabs on the glove box lamp and switch housing together and push the unit out through the mounting hole towards the front of the module (Fig. 14).

REMOVAL AND INSTALLATION (Continued)**Fig. 14 Glove Box Lamp and Switch Remove/Install**

(3) To install the glove box lamp and switch unit, insert the unit through the mounting hole from the front of the glove box module and push in on the unit firmly, until the retaining tabs snap into place.

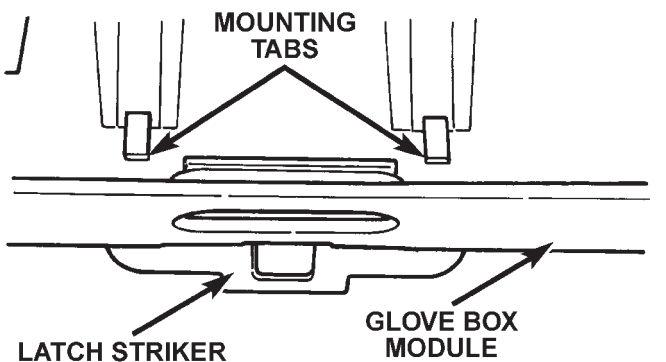
(4) Reverse the remaining removal procedures to complete the installation.

GLOVE BOX LATCH STRIKER

WARNING: ON VEHICLES EQUIPPED WITH AIR-BAGS, REFER TO GROUP 8M - PASSIVE RESTRAINT SYSTEMS BEFORE ATTEMPTING ANY STEERING WHEEL, STEERING COLUMN, OR INSTRUMENT PANEL COMPONENT DIAGNOSIS OR SERVICE. FAILURE TO TAKE THE PROPER PRECAUTIONS COULD RESULT IN ACCIDENTAL AIR-BAG DEPLOYMENT AND POSSIBLE PERSONAL INJURY.

(1) Remove the glove box module from the instrument panel. See Glove Box Module in this group for the procedures.

(2) From the top of the glove box module, straighten the two mounting tabs that secure the glove box latch striker to the glove box module (Fig. 15).

**Fig. 15 Glove Box Latch Striker Remove/Install**

(3) Remove the latch striker through the upper glove box opening of the glove box module.

(4) To install the latch striker, insert the mounting tabs through the slots in the upper glove box opening of the glove box module, and bend the tabs over from the top of the glove box module.

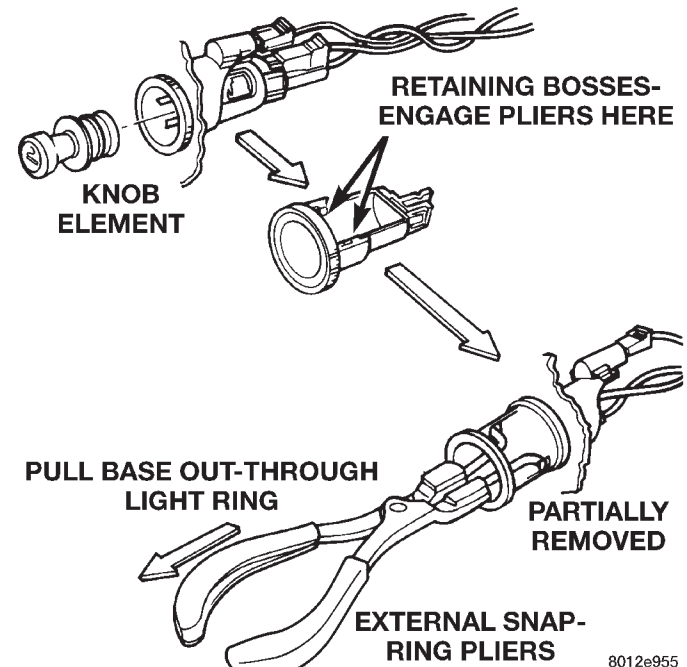
CIGAR LIGHTER

WARNING: ON VEHICLES EQUIPPED WITH AIR-BAGS, REFER TO GROUP 8M - PASSIVE RESTRAINT SYSTEMS BEFORE ATTEMPTING ANY STEERING WHEEL, STEERING COLUMN, OR INSTRUMENT PANEL COMPONENT DIAGNOSIS OR SERVICE. FAILURE TO TAKE THE PROPER PRECAUTIONS COULD RESULT IN ACCIDENTAL AIR-BAG DEPLOYMENT AND POSSIBLE PERSONAL INJURY.

(1) Disconnect and isolate the battery negative cable.

(2) Pull the cigar lighter knob and element out of the cigar lighter base.

(3) Look inside the cigar lighter base and note the position of the retaining bosses that secure the unit to the light ring/retainer in the instrument panel center bezel (Fig. 16).

**Fig. 16 Cigar Lighter Remove/Install**

(4) Insert a pair of external snap ring pliers into the cigar lighter base and engage the tips of the pliers with the retaining bosses.

(5) Squeeze the pliers to disengage the retaining bosses from the base, and using a gentle rocking

REMOVAL AND INSTALLATION (Continued)

motion pull the pliers and the cigar lighter base out of the light ring/retainer.

- (6) Remove the pliers from the cigar lighter base and unplug the cigar lighter wire harness connector.
- (7) Remove the cigar lighter light ring/retainer from the instrument panel center bezel and unplug the light ring lamp wire harness connector.
- (8) Reverse the removal procedures to install.

POWER OUTLET

WARNING: ON VEHICLES EQUIPPED WITH AIR-BAGS, REFER TO GROUP 8M - PASSIVE RESTRAINT SYSTEMS BEFORE ATTEMPTING ANY STEERING WHEEL, STEERING COLUMN, OR INSTRUMENT PANEL COMPONENT DIAGNOSIS OR SERVICE. FAILURE TO TAKE THE PROPER PRECAUTIONS COULD RESULT IN ACCIDENTAL AIR-BAG DEPLOYMENT AND POSSIBLE PERSONAL INJURY.

- (1) Remove the glove box module from the instrument panel. See Glove Box Module in this group for the procedures.
- (2) From the rear of the instrument panel center bezel, unscrew the power outlet receptacle shell clamp from the power outlet receptacle shell base.
- (3) Remove the power outlet receptacle shell base from the front of the instrument panel center bezel.
- (4) Reverse the removal procedures to install.

POWER OUTLET DOOR

- (1) Insert a trim stick or another suitable wide flat-bladed tool between the side of the power outlet housing in the instrument panel center bezel and the upper pivot area of the power outlet door.
- (2) Pry gently against the upper pivot area of the power outlet door until the door pivot pin clears the pivot receptacle in the instrument panel center bezel.
- (3) Pull the power outlet door out of the power outlet housing using a twisting motion.
- (4) To install the door, insert one of the pivot pins into a pivot receptacle in the instrument panel center bezel and twist the door gently until the pivot pin on the opposite side of the door snaps into the other center bezel pivot receptacle.

INSTRUMENT PANEL CENTER BEZEL

WARNING: ON VEHICLES EQUIPPED WITH AIR-BAGS, REFER TO GROUP 8M - PASSIVE RESTRAINT SYSTEMS BEFORE ATTEMPTING ANY STEERING WHEEL, STEERING COLUMN, OR INSTRUMENT PANEL COMPONENT DIAGNOSIS OR SERVICE. FAILURE TO TAKE THE PROPER PRECAUTIONS COULD RESULT IN ACCIDENTAL AIR-

BAG DEPLOYMENT AND POSSIBLE PERSONAL INJURY.

- (1) Remove the glove box module from the instrument panel. See Glove Box Module in this group for the procedures.
- (2) Remove the two screws located on the back side of the glove box module that secure the instrument panel center bezel to the inboard end of the glove box module (Fig. 17).

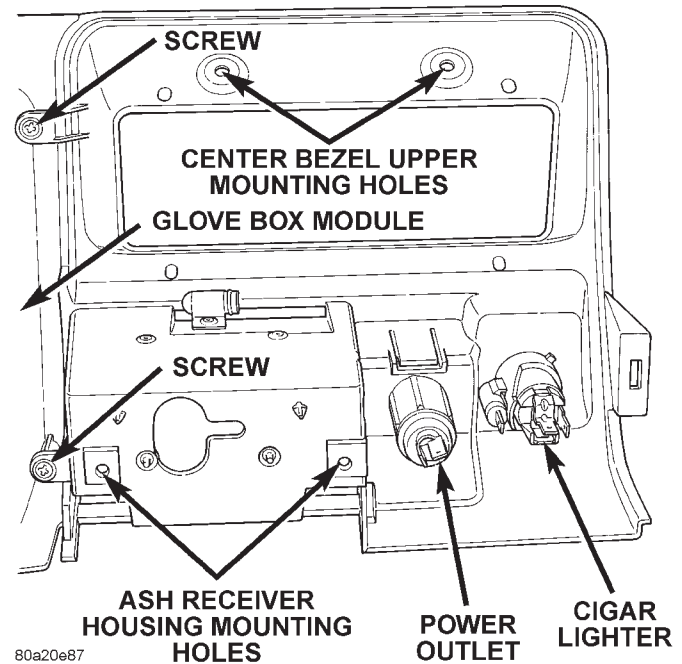


Fig. 17 Instrument Panel Center Bezel Remove/Install

- (3) Reverse the removal procedures to install. Tighten the mounting screws to 2.2 N·m (20 in. lbs.).

GLOVE BOX

WARNING: ON VEHICLES EQUIPPED WITH AIR-BAGS, REFER TO GROUP 8M - PASSIVE RESTRAINT SYSTEMS BEFORE ATTEMPTING ANY STEERING WHEEL, STEERING COLUMN, OR INSTRUMENT PANEL COMPONENT DIAGNOSIS OR SERVICE. FAILURE TO TAKE THE PROPER PRECAUTIONS COULD RESULT IN ACCIDENTAL AIR-BAG DEPLOYMENT AND POSSIBLE PERSONAL INJURY.

- (1) Disconnect and isolate the battery negative cable.
- (2) Drill out the two rivets that secure the glove box hinge to the lower edge of the glove box module (Fig. 18).

REMOVAL AND INSTALLATION (Continued)

NOTE: The rivets are used to ease assembly during the manufacturing process, but do not require replacement following service.

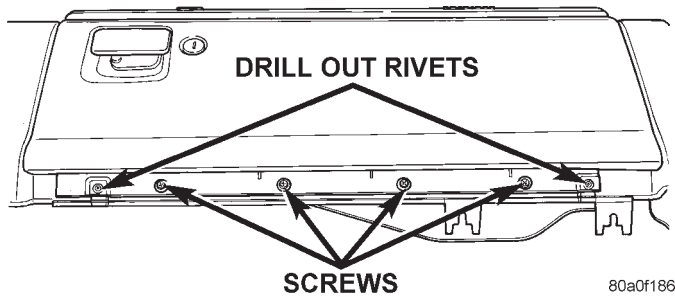


Fig. 18 Glove Box Remove/Install

- (3) Remove the four screws that secure the glove box hinge to the instrument panel armature.
- (4) Release the glove box latch and remove the glove box from the glove box module.
- (5) Reverse the removal procedures to install. Tighten the mounting screws to 2.2 N·m (20 in. lbs.).

GLOVE BOX COMPONENTS

The glove box bezel is the only component of the glove box that can be serviced without glove box removal. All other components will require that the glove box be removed from the instrument panel.

GLOVE BOX BEZEL

- (1) Open the glove box.
- (2) Remove the two screws that secure the bezel to the glove box near the top of the glove box inner door panel (Fig. 19).

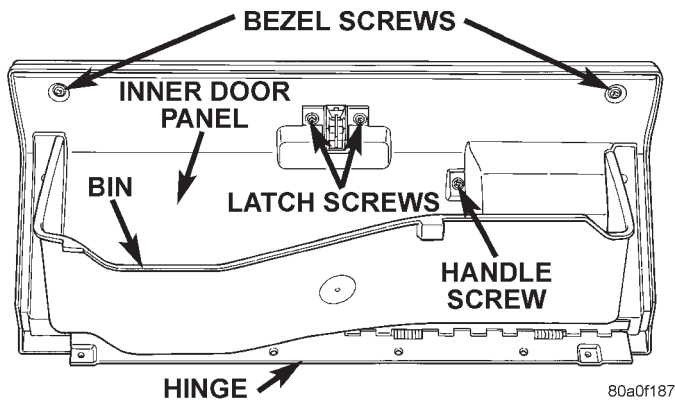


Fig. 19 Glove Box Components

- (3) Using a trim stick or another suitable wide flat-bladed tool, gently pry the bezel away from the outside of the glove box door. There is double-faced adhesive tape between the bezel and the outer door panel.
- (4) Reverse the removal procedures to install. Tighten the mounting screws to 2.2 N·m (20 in. lbs.).

GLOVE BOX HINGE

- (1) Remove the glove box from the instrument panel. See Glove Box in this group for the procedures.
- (2) Remove the screws that secure the glove box hinge to the glove box inner door panel.
- (3) Remove the glove box hinge from the glove box door.
- (4) Reverse the removal procedures to install. Tighten the mounting screws to 2.2 N·m (20 in. lbs.).

GLOVE BOX BIN

- (1) Remove the glove box hinge from the glove box door. See Glove Box Hinge in this group for the procedures.
- (2) Remove the screws that secure each side of the glove box bin to the glove box door.
- (3) Remove the glove box bin from the glove box door.
- (4) Reverse the removal procedures to install. Tighten the mounting screws to 2.2 N·m (20 in. lbs.).

GLOVE BOX LATCH AND HANDLE

- (1) Remove the glove box bin from the glove box door. See Glove Box Bin in this group for the procedures.
- (2) Remove the two bezel screws, two latch screws, and one handle screw from the glove box inner door panel.
- (3) Remove the glove box inner door panel from the glove box outer door panel.
- (4) Remove the screw that secures the glove box latch and handle to the inside of the glove box outer door panel (Fig. 20).

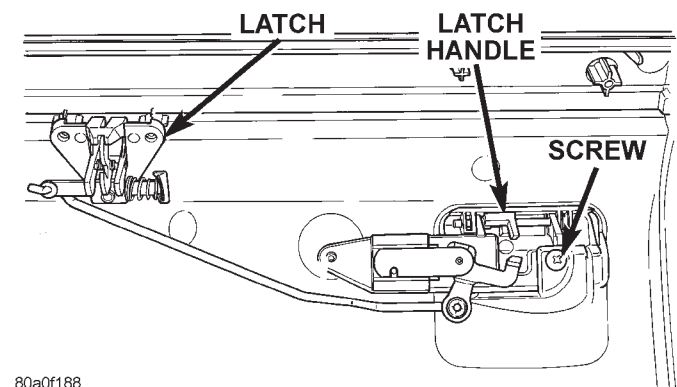


Fig. 20 Glove Box Latch and Handle Remove/Install

- (5) Remove the latch and handle from the glove box door as a unit.
- (6) Reverse the removal procedures to install. Tighten the mounting screws to 2.2 N·m (20 in. lbs.).

REMOVAL AND INSTALLATION (Continued)

GLOVE BOX LOCK CYLINDER

- (1) Remove the glove box latch and handle from the glove box. See Glove Box Latch and Handle in this group for the procedures.
- (2) Insert the glove box key into the glove box lock cylinder.
- (3) Insert a small screwdriver into the retaining tumbler release slot and depress the retaining tumbler (Fig. 21).

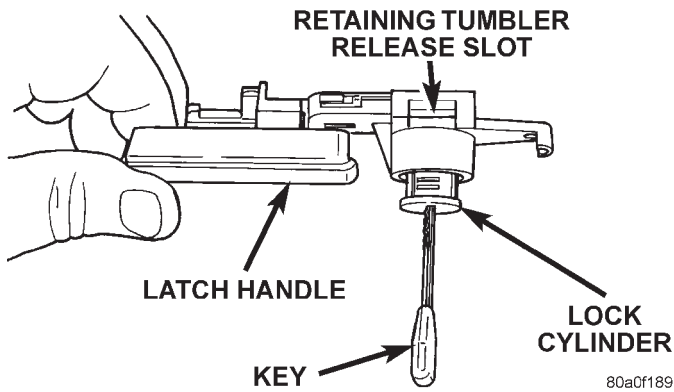


Fig. 21 Glove Box Lock Cylinder Remove/Install

- (4) Pull the lock cylinder out of the latch handle by using a gentle twisting and pulling action on the key.
- (5) Reverse the removal procedures to install.

COWL TOP TRIM PANEL

WARNING: ON VEHICLES EQUIPPED WITH AIR-BAGS, REFER TO GROUP 8M - PASSIVE RESTRAINT SYSTEMS BEFORE ATTEMPTING ANY STEERING WHEEL, STEERING COLUMN, OR INSTRUMENT PANEL COMPONENT DIAGNOSIS OR SERVICE. FAILURE TO TAKE THE PROPER PRECAUTIONS COULD RESULT IN ACCIDENTAL AIR-BAG DEPLOYMENT AND POSSIBLE PERSONAL INJURY.

- (1) Disconnect and isolate the battery negative cable.
- (2) Using a trim stick or another suitable wide flat-bladed tool, gently pry the cowl top trim panel off of the instrument panel top pad (Fig. 22).
- (3) Pull the trim panel up far enough to access and unplug the wire harness connector for the solar sensor, or to remove the solar sensor from the cowl top trim, if the vehicle is so equipped.
- (4) Remove the cowl top trim panel from the instrument panel.
- (5) Reverse the removal procedures to install.

INSTRUMENT PANEL TOP PAD

WARNING: ON VEHICLES EQUIPPED WITH AIR-BAGS, REFER TO GROUP 8M - PASSIVE

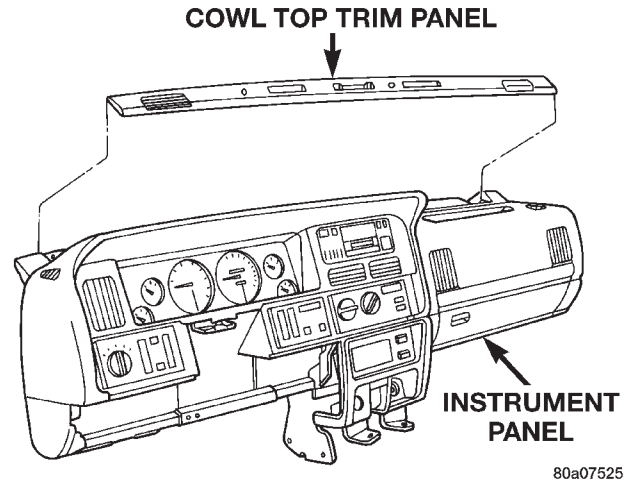


Fig. 22 Cowl Top Trim Remove/Install

RESTRAINT SYSTEMS BEFORE ATTEMPTING ANY STEERING WHEEL, STEERING COLUMN, OR INSTRUMENT PANEL COMPONENT DIAGNOSIS OR SERVICE. FAILURE TO TAKE THE PROPER PRECAUTIONS COULD RESULT IN ACCIDENTAL AIR-BAG DEPLOYMENT AND POSSIBLE PERSONAL INJURY.

- (1) Disconnect and isolate the battery negative cable.
- (2) Remove the steering column opening cover and knee blocker from the instrument panel. See Steering Column Opening Cover and Knee Blocker in this group for the procedures.
- (3) Remove the cluster bezel from the instrument panel. See Cluster Bezel in this group for the procedures.
- (4) Remove the glove box module from the instrument panel. See Glove Box Module in this group for the procedures.
- (5) Remove the cowl top trim panel from the instrument panel. See Cowl Top Trim Panel in this group for the procedures.
- (6) If the vehicle is so equipped, remove the screw that secures the auto headlamp light sensor/vehicle theft security system lamp to the top of the instrument panel near the defroster duct outlet, and move it far enough for clearance during removal of the instrument panel top pad.
- (7) Remove all of the screws that secure the perimeter of the instrument panel top pad to the instrument panel armature.
- (8) Remove the instrument panel top pad from the instrument panel armature.
- (9) Reverse the removal procedures to install. Tighten the mounting screws to 2.2 N·m (20 in. lbs.).

REMOVAL AND INSTALLATION (Continued)**JUNCTION BLOCK**

WARNING: ON VEHICLES EQUIPPED WITH AIR-BAGS, REFER TO GROUP 8M - PASSIVE RESTRAINT SYSTEMS BEFORE ATTEMPTING ANY STEERING WHEEL, STEERING COLUMN, OR INSTRUMENT PANEL COMPONENT DIAGNOSIS OR SERVICE. FAILURE TO TAKE THE PROPER PRECAUTIONS COULD RESULT IN ACCIDENTAL AIR-BAG DEPLOYMENT AND POSSIBLE PERSONAL INJURY.

- (1) Disconnect and isolate the battery negative cable.
- (2) Remove the fuse access panel by unsnapping it from the right cowl side trim panel.
- (3) Remove the push nut that secures the right cowl side trim panel to the junction block stud (Fig. 23).

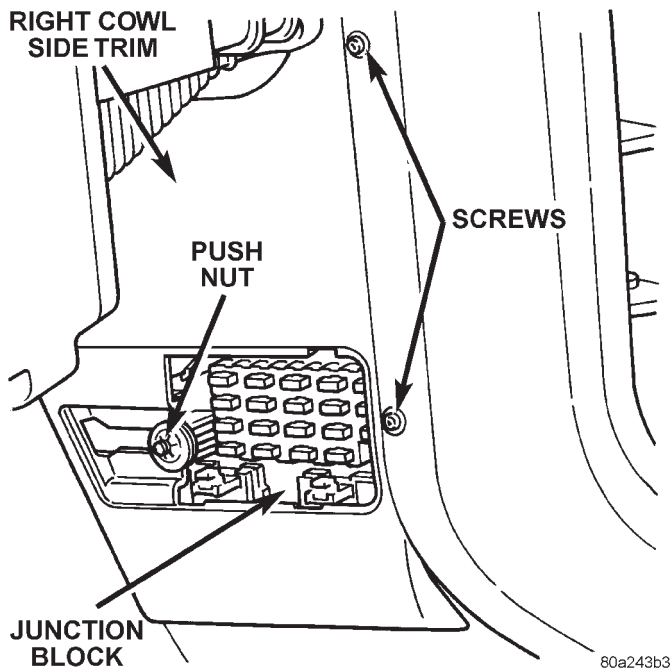


Fig. 23 Right Cowl Side Trim Panel Remove/Install

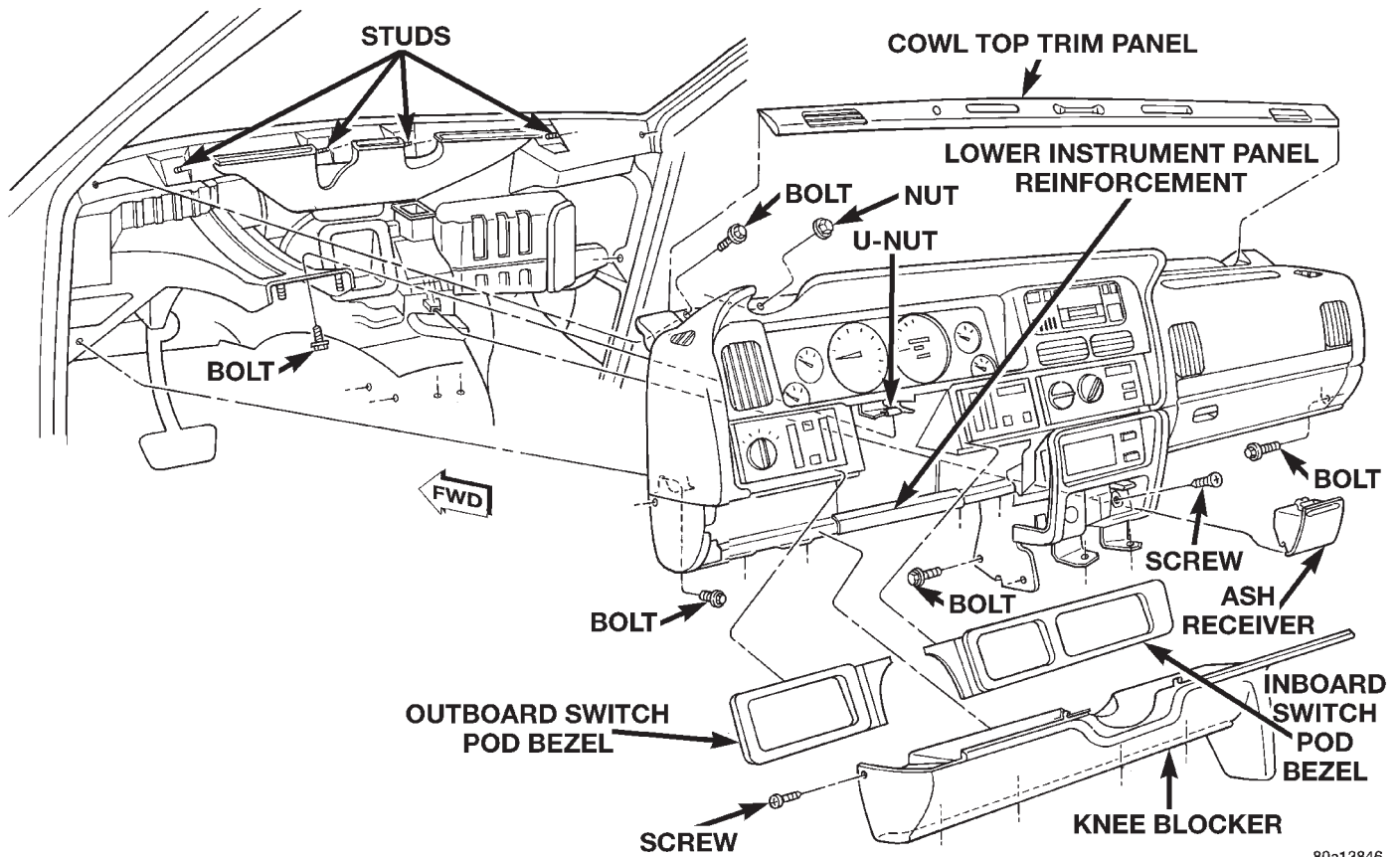
- (4) Remove the two screws that secure the right cowl side trim panel to the right front door opening trim.
- (5) Remove the right cowl side trim panel from the right cowl side inner panel.
- (6) Unplug all of the wire harness connectors from the junction block cavities.
- (7) Remove the two screws that secure the junction block to the mounting bracket on the right cowl side inner panel.
- (8) Remove the junction block from the mounting bracket on the right cowl side inner panel.
- (9) Reverse the removal procedures to install. Tighten the mounting screws to 2.2 N·m (20 in. lbs.).

INSTRUMENT PANEL ASSEMBLY

WARNING: ON VEHICLES EQUIPPED WITH AIR-BAGS, REFER TO GROUP 8M - PASSIVE RESTRAINT SYSTEMS BEFORE ATTEMPTING ANY STEERING WHEEL, STEERING COLUMN, OR INSTRUMENT PANEL COMPONENT DIAGNOSIS OR SERVICE. FAILURE TO TAKE THE PROPER PRECAUTIONS COULD RESULT IN ACCIDENTAL AIR-BAG DEPLOYMENT AND POSSIBLE PERSONAL INJURY.

- (1) Disconnect and isolate the battery negative cable.
- (2) Remove the steering column opening cover and knee blocker from the instrument panel. See Steering Column Opening Cover and Knee Blocker in this group for the procedures.
- (3) Remove the bolts that secure the lower instrument panel reinforcement to the instrument panel armature and remove the reinforcement (Fig. 24).
- (4) Remove the upper and lower steering column shrouds from the steering column. Refer to Group 19 - Steering for the procedures.
- (5) Unplug all of the wire harness connectors from the steering column-mounted components and switches.
- (6) Remove the three nuts that secure the steering column toe plate to the dash panel at the base of the steering column.
- (7) Remove the two nuts that secure the steering column mounting bracket to the studs on the steering column and brake pedal support. Lower the steering column to the floor.
- (8) Remove both cowl side trim panels. Refer to Group 23 - Body for the procedures.
- (9) Unplug the instrument panel to body wire harness connector under the left end of the instrument panel.
- (10) Unplug the brake lamp switch wire harness connector.
- (11) Unplug the instrument panel to heater-A/C housing vacuum harness connector (manual temperature control only) and wire harness connector located under the passenger side end of the instrument panel.
- (12) Unplug the radio antenna coaxial cable connector near the right cowl side panel.
- (13) Unplug all of the instrument panel wire harness connectors from the junction block on the right cowl side panel.
- (14) If the vehicle is so equipped, disconnect the in-car temperature sensor aspirator hose at the coupling near the passenger side of the transmission floor tunnel.
- (15) Remove the ash receiver and remove the screw in the back of the ash receiver housing that

REMOVAL AND INSTALLATION (Continued)



80a13846

Fig. 24 Instrument Panel Assembly Remove/Install

secures the instrument panel armature to the heater-A/C housing.

(16) Pull back the floor carpet on the transmission floor tunnel from the base of the instrument panel center bezel and remove the two bolts that secure the instrument panel center bracket to the floor.

(17) Remove the two bolts that secure the instrument panel center bracket to the driver side of the transmission floor tunnel.

(18) Remove the bolt that secures the instrument panel armature to the steering column and brake pedal support.

(19) Remove the two bolts that secure the ends of the instrument panel armature to the cowl side inner panels.

(20) Remove the cowl top trim panel from the instrument panel. See Cowl Top Trim Panel in this group for the procedures.

(21) Remove the two bolts that secure the ends of the instrument panel armature to the windshield fence.

(22) Remove the four nuts that secure the top of the instrument panel armature to the studs on the windshield fence.

(23) With the aid of an assistant, lift the instrument panel off of the windshield fence studs and maneuver the assembly out of the vehicle through the passenger side front door.

(24) Reverse the removal procedures to install. Tighten the mounting hardware as follows:

- Instrument panel center bracket to floor pan transmission tunnel fasteners - 28 N·m (250 in. lbs.)
- Instrument panel to windshield fence bolts and nuts - 12 N·m (105 in. lbs.)
- Instrument panel to cowl side inner panel bolts - 12 N·m (105 in. lbs.)
- Instrument panel to steering column support bolt - 12 N·m (105 in. lbs.)

INSTRUMENT PANEL SYSTEMS

CONTENTS

	page		page
GENERAL INFORMATION			
BODY CONTROL MODULE	4	GRAPHIC DISPLAY MODULE	15
GAUGE	3	HEADLAMP HIGH BEAM INDICATOR LAMP ..	16
GRAPHIC DISPLAY MODULE	3	INSTRUMENT CLUSTER	10
INDICATOR LAMP	4	LOW FUEL WARNING LAMP	16
INSTRUMENT CLUSTER	2	MALFUNCTION INDICATOR LAMP	17
INSTRUMENT PANEL	2	MASTER LIGHTING INDICATOR LAMP	17
INTRODUCTION	2	ODOMETER AND TRIP ODOMETER	11
JUNCTION BLOCK	4	OIL PRESSURE GAUGE	11
VEHICLE INFORMATION CENTER	3	SEAT BELT REMINDER LAMP	17
DESCRIPTION AND OPERATION			
AIRBAG INDICATOR LAMP	7	SPEEDOMETER	12
ANTI-LOCK BRAKE SYSTEM LAMP	7	TACHOMETER	12
BRAKE WARNING LAMP	7	TURN SIGNAL INDICATOR LAMP	18
CHECK GAUGES LAMP	7	UPSHIFT INDICATOR LAMP	18
CLUSTER ILLUMINATION LAMP	8	VEHICLE INFORMATION CENTER	18
COOLANT TEMPERATURE GAUGE	5	VOLTMETER	12
CRUISE-ON INDICATOR LAMP	8	WAIT-TO-START LAMP	21
FUEL GAUGE	5	WATER-IN-FUEL LAMP	21
HEADLAMP HIGH BEAM INDICATOR LAMP ..	8	SERVICE PROCEDURES	
LOW FUEL WARNING LAMP	8	VEHICLE INFORMATION CENTER	22
MALFUNCTION INDICATOR LAMP	9	REMOVAL AND INSTALLATION	
MASTER LIGHTING INDICATOR LAMP	9	BODY CONTROL MODULE	29
ODOMETER AND TRIP ODOMETER	5	CIGAR LIGHTER	31
OIL PRESSURE GAUGE	6	CLUSTER BEZEL	25
SEAT BELT REMINDER LAMP	9	CLUSTER BULB	28
SPEEDOMETER	6	CLUSTER LENS, HOOD, AND MASK	26
TACHOMETER	6	COWL TOP TRIM PANEL	34
TURN SIGNAL INDICATOR LAMP	9	GAUGE	27
UPSHIFT INDICATOR LAMP	9	GLOVE BOX	32
VOLTMETER	6	GLOVE BOX COMPONENTS	33
WAIT-TO-START LAMP	10	GLOVE BOX LAMP AND SWITCH	30
WATER-IN-FUEL LAMP	10	GLOVE BOX LATCH STRIKER	31
DIAGNOSIS AND TESTING			
AIRBAG INDICATOR LAMP	12	GLOVE BOX MODULE	30
ANTI-LOCK BRAKE SYSTEM LAMP	13	GRAPHIC DISPLAY MODULE AND VEHICLE	
BRAKE WARNING LAMP	13	INFORMATION CENTER	30
CHECK GAUGES LAMP	14	INBOARD SWITCH POD	29
CLUSTER ILLUMINATION LAMP	14	INSTRUMENT CLUSTER	26
COOLANT TEMPERATURE GAUGE	11	INSTRUMENT PANEL ASSEMBLY	35
CRUISE-ON INDICATOR LAMP	14	INSTRUMENT PANEL CENTER BEZEL	32
FUEL GAUGE	11	INSTRUMENT PANEL TOP PAD	34
		JUNCTION BLOCK	35
		OUTBOARD SWITCH POD	28
		POWER OUTLET DOOR	32

POWER OUTLET	32
STEERING COLUMN OPENING COVER AND KNEE BLOCKER	25

SWITCH POD BEZEL	25
------------------------	----

GENERAL INFORMATION

INTRODUCTION

This group is responsible for covering the vehicle instrument panel. However, because the instrument panel serves as the command center of the vehicle, it is a very complex unit. The instrument panel is designed to house the controls and monitors for standard and optional powertrains, climate control systems, audio systems, lighting systems, safety systems and many other comfort or convenience items. It is also designed so that all of the controls and monitors can be safely reached and viewed by the vehicle operator, while still allowing relative ease of access to these items for service.

Complete service information coverage for all of the systems and components housed in the instrument panel in this section of the service manual would not be practical. It would result in a great deal of duplication and make this group too large for the information to be easily accessed and used. Therefore, the information found in this group has been limited as follows:

- General Information - Covers non-electrical components and features of the instrument panel that are not related to other systems.
- Description and Operation - Covers gauges and their sending units, warning lamps and their switches, and instrument panel illumination lamps.
- Diagnosis and Testing - Covers gauges and their sending units, warning lamps and their switches, and instrument panel illumination lamps.
- Removal and Installation - Covers all components installed on or in the instrument panel that require removal for diagnosis or service of any other instrument panel components covered in this group.

For more information on components or systems not covered above, refer to the proper group in this manual. If you are uncertain as to the proper group, refer to the Component and System Index at the back of this manual. Refer to Group 8W - Wiring Diagrams for complete circuit descriptions and diagrams.

NOTE: This group covers both Left-Hand Drive (LHD) and Right-Hand Drive (RHD) versions of this model. Whenever required and feasible, the RHD versions of affected vehicle components have been constructed as mirror-image of the LHD versions. While most of the illustrations used in this group represent only the LHD version, the diagnostic and service procedures outlined can generally be applied to either version. Exceptions to this rule

have been clearly identified as LHD or RHD, if a special illustration or procedure is required.

INSTRUMENT PANEL

Modular construction allows all of the gauges and controls to be serviced from the front of the instrument panel. In addition, most of the instrument electrical or heating and air conditioning components can be accessed without complete instrument panel removal. If necessary, the instrument panel can be rolled-down and removed from the vehicle as an assembly.

Removal of the switch pod bezels allows access to most of the switches and the heating and air conditioning controls. Removal of the instrument cluster bezel allows access to the cluster assembly and the radio. Removal of the cluster assembly allows access to the individual gauges, the cluster illumination and indicator lamp bulbs, and much of the instrument panel wiring.

Removal of the steering column opening cover/knee blocker provides access to the steering column mounts, the Body Control Module (BCM), the gear-shift interlock mechanism, and additional instrument panel and steering column wiring. Removal of the glove box module and center bezel unit allows access to the Vehicle Information Center (VIC), the Graphic Display Module (GDM), the in-vehicle temperature sensor, additional instrument panel wiring, and many of the heating and air conditioning components.

Removal of the instrument panel cowl top trim panel allows access to the instrument panel speakers, the solar sensor, and the automatic headlamp light sensor/vehicle theft security system lamp. Removal of the instrument panel top pad allows access to the passenger side airbag module.

Instrument panel removal is required for service of most internal components of the heating and air conditioning housing.

INSTRUMENT CLUSTER

One basic instrument cluster option is offered on Grand Cherokee models. This cluster is an electromechanical unit that utilizes integrated circuitry and information carried on the Chrysler Collision Detection (CCD) data bus network for control of all gauges and most indicator lamps. This cluster also incorporates a vacuum fluorescent display tube for the digital odometer and trip odometer display functions. Some variations of the cluster exist due to optional equipment and regulatory requirements.

GENERAL INFORMATION (Continued)

The cluster includes the following analog gauges:

- Coolant temperature gauge
- Fuel gauge
- Oil pressure gauge
- Speedometer
- Tachometer
- Voltmeter.

This cluster includes provisions for the following indicator lamps:

- Airbag indicator lamp
- Anti-lock brake system lamp
- Brake warning lamp
- Check gauges lamp
- Cruise-on indicator lamp
- Headlamp high beam indicator lamp
- Low fuel warning lamp
- Malfunction indicator (Check Engine) lamp
- Master lighting indicator lamp
- Seat belt reminder lamp
- Turn signal indicator lamps
- Upshift indicator lamp (manual transmission)
- Wait-to-start lamp (diesel engine)
- Water-in-fuel lamp (diesel engine).

GRAPHIC DISPLAY MODULE

A Graphic Display Module (GDM) is standard equipment on all four-wheel drive Grand Cherokee models, unless the vehicle is equipped with the optional Vehicle Information Center (VIC). The GDM is mounted in the lower center stack area of the instrument panel, above the ash receiver and below the heater and air conditioner controls. Two-wheel drive Grand Cherokee models have a storage bin installed in place of the GDM as standard equipment.

The GDM display consists of a back-lit screen with an outline of the vehicle. The two rear wheels of the vehicle outline are illuminated by a lamp when the transfer case is engaged in any two-wheel drive operating mode. The two front wheels are also illuminated when the transfer case is engaged in any four-wheel drive operating mode.

The GDM also has up to three indicator lamps, which indicate to the driver whether the four-wheel drive mode selected is Lo, Part-Time, or Full-Time. The number of operational indicator lamps may vary, depending upon the optional four-wheel drive transfer case in the vehicle. A switch on the transfer case is hard-wired to the GDM so as to illuminate the proper wheels and indicator lamps.

The GDM bulbs and the transfer case switch can be serviced. However, if any other part of the GDM is damaged or faulty, the entire GDM must be replaced. Refer to Group 21 - Transmission and Transfer Case for the transfer case switch service procedures.

VEHICLE INFORMATION CENTER

The Vehicle Information Center (VIC) is an available option on Grand Cherokee models. The VIC module replaces the standard equipment Graphic Display Module (GDM). The VIC is mounted in the lower center stack area of the instrument panel, above the ash receiver and below the heater and air conditioner controls.

The VIC consists of a multicolored vacuum fluorescent display screen with an outline of the vehicle. The VIC is able to display four functions in a choice of five languages. The display functions include:

- Current time (12 or 24 hour clock), day, and date
- Monitor specific vehicle operating systems and alert the driver of a malfunction in a monitored system
- Provide service reminders or the distance to the next service interval
- The current transfer case mode of operation (four-wheel drive models).

The VIC display language choices include:

- English
- French
- German
- Italian
- Spanish.

The VIC receives input from hard-wired sensors and over the Chrysler Collision Detection (CCD) data bus network. In response to these inputs the VIC offers a combination of graphic and message displays, and provides requests for audible chime alerts to the Body Control Module (BCM) on the CCD data bus network.

Refer to the owner's manual for more information on the VIC controls, operation, and setting procedures. For diagnosis of the VIC module or the CCD data bus, refer to the proper Diagnostic Procedures manual. The VIC module cannot be repaired. If damaged or faulty, the entire module must be replaced.

GAUGE

With the ignition switch in the On or Start positions, voltage is supplied to all gauges through the instrument cluster electronic circuit board. With the ignition switch in the Off position, voltage is not supplied to the gauges. The gauges do not accurately indicate any vehicle condition unless the ignition switch is in the On or Start positions.

All of the instrument cluster gauges, except the odometer, are air core magnetic units. Two fixed electromagnetic coils are located within the gauge. These coils are wrapped at right angles to each other around a movable permanent magnet. The movable magnet is suspended within the coils on one end of a shaft. The gauge needle is attached to the other end of the shaft.

GENERAL INFORMATION (Continued)

One of the coils has a fixed current flowing through it to maintain a constant magnetic field strength. Current flow through the second coil changes, which causes changes in its magnetic field strength. The current flowing through the second coil is changed by the instrument cluster electronic circuitry in response to messages received on the Chrysler Collision Detection (CCD) data bus network.

The gauge needle moves as the movable permanent magnet aligns itself to the changing magnetic fields created around it by the electromagnets. These gauges also feature a small fixed permanent magnet which will move all of the gauge needles back to the low end of their respective scales after the ignition switch is turned to the Off position.

INDICATOR LAMP

Indicator lamps are located in the instrument cluster, and in the Graphic Display Module (GDM) or the Vehicle Information Center (VIC). Those lamps within the instrument cluster are served by the cluster circuit board and wire harness connectors. Those lamps located in the GDM or VIC modules are served by the GDM or VIC circuit board and wire harness connectors.

Most of the indicator lamps in the instrument cluster and VIC module are controlled by the instrument cluster or VIC module electronic circuitry in response to messages received over the Chrysler Collision Detection (CCD) data bus network from the Body Control Module (BCM), Powertrain Control Module (PCM), and Airbag Control Module (ACM). Only the anti-lock brake system lamp, four-wheel drive indicator lamps, lamp outage warning lamp, low coolant level warning lamp, low washer fluid warning lamp, master lighting indicator lamp, and turn signal indicator lamps are hard-wired.

BODY CONTROL MODULE

A Body Control Module (BCM) is used on this model to control and integrate many of the electronic functions and features included on the vehicle. The BCM contains a central processing unit and interfaces with other modules in the vehicle on the Chrysler Collision Detection (CCD) data bus network.

The CCD data bus network allows the sharing of sensor information. This helps to reduce wire harness complexity, reduce internal controller hardware, and reduce component sensor current loads. At the same time, this system provides increased reliability, enhanced diagnostics, and allows the addition of many new feature capabilities.

Some of the functions and features that the BCM supports or controls, include:

- Chimes
- Automatic headlamp control

- Headlamp delay
- Headlamps on with ignition off and driver door open warning
 - Key in ignition with ignition off and driver door open warning
 - Automatic funeral or parade mode
 - Panel lamp dimming
 - Vehicle Theft Security System (VTSS)
 - Vehicle immobilizer system
 - Illuminated entry
 - Heated rear window and heated outside mirror control
 - Intermittent wipe control
 - Monitoring and transmitting door, hood, liftgate, liftglass ajar data
 - Monitoring and transmitting outside ambient temperature data
 - Monitoring and transmitting air conditioning select switch data
 - Courtesy lamp time-out
 - Gulf coast country over-speed warning
 - Door lock inhibit
 - Electronic odometer and trip odometer
 - Brake warning lamp
 - Check gauges lamp
 - High beam indicator lamp
 - Seatbelt reminder lamp and chime
 - Speed sensitive intermittent wipe
 - Fog lamp control
 - Electromechanical instrument cluster
 - BCM diagnostic support
 - Vehicle Information Center (VIC) support
 - Rolling door locks
 - Horn chirp upon door lock with Remote Keyless Entry (RKE)(programmable)
 - Low fuel warning chime (programmable)
 - Headlights on with wipers (programmable - with automatic headlamps only)

The BCM is mounted under the driver side outboard end of the instrument panel, behind the instrument panel support armature and below the outboard switch pod. For diagnosis of the BCM or the CCD data bus, the use of a DRB scan tool and the proper Diagnostic Procedures manual are recommended. The BCM can only be serviced by an authorized electronic repair station. Refer to the latest Warranty Policies and Procedures manual for a current listing of authorized electronic repair stations.

JUNCTION BLOCK

The junction block is mounted on the right cowl side inner panel below the right end of the instrument panel. It is concealed behind the right cowl side trim panel. The junction block serves to simplify and centralize numerous electrical components.

GENERAL INFORMATION (Continued)

The junction block combines the functions previously provided by a separate fuseblock module and relay center. It contains fuses, circuit breakers and relays. It also eliminates the need for numerous splice connections and serves in place of a bulkhead connector between many of the engine compartment, instrument panel, and body wire harnesses.

The right cowl side trim panel has a snap-fit fuse access cover that can be removed for service of the junction block fuses. A fuse puller and spare fuse holders are located on the back of the fuse access panel. The right cowl side trim panel must be removed to access the relays in the junction block.

The junction block cannot be repaired and, if faulty or damaged, it must be replaced.

DESCRIPTION AND OPERATION

COOLANT TEMPERATURE GAUGE

The coolant temperature gauge gives an indication of the engine coolant temperature. The instrument cluster circuitry controls the gauge pointer position. The instrument cluster circuitry calculates the proper gauge pointer position based upon an engine coolant temperature message received from the Powertrain Control Module (PCM) on the Chrysler Collision Detection (CCD) data bus.

The PCM uses an input from the engine coolant temperature sensor and internal programming to decide what engine coolant temperature message is required. The PCM then sends the proper message to the instrument cluster and the Body Control Module (BCM) on the CCD data bus.

The BCM also monitors the PCM engine coolant temperature messages. If the PCM message indicates that coolant temperature is high or critical, the BCM sends a message to the instrument cluster to turn on the Check Gauges lamp and to move the coolant temperature gauge needle to the corresponding high or critical position of the gauge scale.

The engine coolant temperature sensor is installed in a threaded hole that penetrates a coolant passage of the engine. It is a thermistor-type sensor that changes its internal resistance with changes in engine coolant temperature. Refer to Group 14 - Fuel Systems for more information on the PCM and the coolant temperature sensor.

FUEL GAUGE

The fuel gauge gives an indication of the level of fuel in the fuel tank. The instrument cluster circuitry controls the gauge pointer position. The instrument cluster circuitry calculates the proper gauge pointer position based upon a fuel level message received

from the Powertrain Control Module (PCM) on the Chrysler Collision Detection (CCD) data bus.

The PCM uses an input from the fuel gauge sending unit and internal programming to decide what fuel level message is required. The PCM then sends the proper message to the instrument cluster and the Body Control Module (BCM) on the CCD data bus.

The BCM monitors the PCM fuel level messages. If the PCM message indicates that the fuel level is below one-eighth of a full tank, the BCM issues a single audible low fuel chime tone and sends a message to the instrument cluster to turn on the low fuel warning lamp. If the PCM detects a short or open in the fuel level sending unit circuit, it sends a message on the CCD data bus that will cause the instrument cluster circuitry to position the fuel gauge needle at the Empty stop.

The fuel gauge sending unit is mounted to the electric fuel pump module located inside the fuel tank. The sending unit has a float attached to the end of a swing-arm. The float moves up or down within the fuel tank as the fuel level changes. As the float moves, an electrical contact on the pivot end of the swing-arm wipes across a resistor coil, which changes the internal electrical resistance of the sending unit. Refer to Group 14 - Fuel Systems for more information on the PCM and for the fuel gauge sending unit service procedures.

ODOMETER AND TRIP ODOMETER

The odometer and the trip odometer share the same vacuum fluorescent digital display tube in the instrument cluster circuit board. Each gives an indication of the distance the vehicle has travelled. However, by depressing the reset knob on the face of the instrument cluster, the display mode can be switched from odometer to trip odometer. Depressing the reset knob for longer than two seconds while in the trip odometer mode will reset the trip odometer to zero. The odometer and trip odometer display values are based on distance messages received from the Body Control Module (BCM) on the Chrysler Collision Detection (CCD) data bus.

The BCM uses a distance pulse message relayed from the Powertrain Control Module (PCM) on the CCD data bus and internal programming to decide what distance message is required. The PCM receives the distance pulse signal input from the Vehicle Speed Sensor (VSS) to relay to the BCM on the CCD data bus. The BCM stores both the odometer and trip odometer distance information and sends the proper value to the instrument cluster based upon ignition key-on and trip odometer reset knob messages received on the CCD data bus.

DESCRIPTION AND OPERATION (Continued)

If the instrument cluster is not receiving distance information on the CCD data bus when the ignition switch is turned to the On position, the odometer display will remain blank. If the instrument cluster does not receive a distance message on the CCD data bus after the ignition switch has been turned to the On position, the instrument panel circuitry will insert the last normally displayed distance in the odometer display.

The VSS is a hall-effect sensor that is installed in the transmission (two-wheel drive) or transfer case (four-wheel drive), and is driven by the output shaft through a speedometer pinion gear. Incorrect tire size, incorrect axle ratio, a faulty or incorrect speedometer pinion gear, or a faulty VSS can each result in inaccurate odometer readings. Refer to Group 14 - Fuel Systems for more information on the PCM and the VSS. Refer to Group 21 - Transmission for more information on the speedometer pinion gear.

OIL PRESSURE GAUGE

The oil pressure gauge gives an indication of the engine oil pressure. The instrument cluster circuitry controls the gauge pointer position. The instrument cluster circuitry calculates the proper gauge pointer position based upon an engine oil pressure message received from the Powertrain Control Module (PCM) on the Chrysler Collision Detection (CCD) data bus.

The PCM uses an input from the engine oil pressure sensor and internal programming to decide what engine oil pressure message is required. The PCM then sends the proper message to the instrument cluster and the Body Control Module (BCM) on the CCD data bus.

The BCM also monitors the PCM engine oil pressure messages. If the PCM message indicates that engine oil pressure is low, the BCM sends a message to the instrument cluster to turn on the Check Gauges lamp and to move the oil pressure gauge needle to the zero end of the gauge scale.

The engine oil pressure sensor is installed in a threaded hole that penetrates an oil passage of the engine. The engine oil pressure sensor contains a flexible diaphragm and a variable resistor coil. The diaphragm moves in response to changes in the engine oil pressure, which changes the internal electrical resistance of the sensor. Refer to Group 14 - Fuel Systems for more information on the PCM and the engine oil pressure sensor.

SPEEDOMETER

The speedometer gives an indication of the current vehicle speed. The instrument cluster circuitry controls the gauge pointer position. The instrument cluster circuitry calculates the proper gauge pointer position based upon a vehicle speed message received

from the Powertrain Control Module (PCM) on the Chrysler Collision Detection (CCD) data bus.

The PCM uses an input from the Vehicle Speed Sensor (VSS) and internal programming to decide what vehicle speed message is required. The PCM then sends the proper message to the instrument cluster on the CCD data bus.

The VSS is a hall-effect sensor that is installed in the transmission (two-wheel drive) or transfer case (four-wheel drive), and is driven by the output shaft through a speedometer pinion gear. Incorrect tire size, incorrect axle ratio, a faulty or incorrect speedometer pinion gear, or a faulty VSS can each result in inaccurate speedometer readings.

Refer to Group 14 - Fuel Systems for more information on the PCM and the VSS. Refer to Group 21 - Transmission for more information on the speedometer pinion gear.

TACHOMETER

The tachometer gives an indication of the engine speed in revolutions-per-minute (RPM). The instrument cluster circuitry controls the gauge pointer position. The instrument cluster circuitry calculates the proper gauge pointer position based upon an engine speed message received from the Powertrain Control Module (PCM) on the Chrysler Collision Detection (CCD) data bus.

The PCM uses an input from the crankshaft position sensor and internal programming to decide what engine speed message is required. The PCM then sends the proper message to the instrument cluster on the CCD data bus. The crankshaft position sensor is a hall-effect sensor installed near the rear of the engine, where it is aimed at the trigger wheel attached to the rear flange of the crankshaft.

Refer to Group 14 Fuel Systems for more information on the PCM. For models with a gasoline engine, refer to Group 8D - Ignition Systems for more information on the crankshaft position sensor. For models with a diesel engine, refer to Group 14 - Fuel Systems for more information on the crankshaft position sensor.

VOLTMETER

The voltmeter gives an indication of the electrical system voltage. The instrument cluster circuitry controls the gauge pointer position. The instrument cluster circuitry calculates the proper gauge pointer position based upon a system voltage message received from the Powertrain Control Module (PCM) on the Chrysler Collision Detection (CCD) data bus.

The PCM uses an input from the electrical system and internal programming to decide what system voltage message is required. The PCM then sends

DESCRIPTION AND OPERATION (Continued)

the proper message to the instrument cluster on the CCD data bus.

Refer to Group 14 - Fuel System for more information on the PCM. Refer to Group 8C - Charging System for more information on charging system components and diagnosis.

AIRBAG INDICATOR LAMP

The airbag indicator lamp gives an indication when the airbag system is faulty or inoperative. The lamp is turned on by the instrument cluster circuitry for about seven seconds when the ignition switch is turned to the On position as a bulb test. After the bulb test, the lamp is controlled by the instrument cluster circuitry based upon a message received from the Airbag Control Module (ACM) on the Chrysler Collision Detection (CCD) data bus.

The ACM continually monitors the airbag system circuits and sensors to decide whether the system is in good operating condition. The ACM then sends the proper message to the instrument cluster on the CCD data bus to turn the lamp on or off. If the ACM sends a lamp-on message after the bulb test, it indicates that the ACM has detected a system malfunction and/or that the airbag system has become inoperative. Each time the instrument cluster circuitry receives a lamp-on message from the ACM, it will light the lamp for twelve seconds or the duration of the airbag system malfunction, whichever is longer.

The airbag indicator lamp also has a lamp backup feature. Following the seat belt reminder lamp display function, if an inoperative airbag warning lamp circuit was detected during the bulb test sequence, the instrument cluster circuitry will flash the seat belt reminder lamp on and off for about twenty seconds. If the seat belt reminder lamp flashes longer than twenty seconds, or flashes at any time other than about twenty seconds after the initial ignition-on sequence, it indicates an airbag system fault has been detected and that the airbag indicator lamp is inoperative.

Refer to Group 8M - Passive Restraint Systems for more information on the airbag system.

ANTI-LOCK BRAKE SYSTEM LAMP

The Anti-Lock Brake System (ABS) lamp gives an indication when the ABS system is faulty or inoperative. The lamp is hard-wired in the instrument cluster, and is completely controlled by the Controller Anti-lock Brake (CAB).

The ABS lamp receives battery voltage through the instrument cluster fused ignition switch output feed circuit, and is grounded by the CAB. The lamp is turned on by the CAB for about two seconds when the ignition switch is turned to the On position as a

bulb test. After the bulb test, the CAB turns the lamp on or off based upon the results of the ABS system self-tests.

The CAB continually monitors the ABS circuits and sensors to decide whether the system is in good operating condition. If the CAB turns the lamp on after the bulb test, it indicates that the CAB has detected a system malfunction and/or that the ABS system has become inoperative. Refer to Group 5 - Brakes for more information.

BRAKE WARNING LAMP

The brake warning lamp gives an indication when the parking brake is applied, or when the pressures in the two halves of the split brake hydraulic system are unequal. The lamp is turned on by the instrument cluster circuitry for about four seconds when the ignition switch is turned to the On position as a bulb test. After the bulb test, the lamp is controlled by the instrument cluster circuitry based upon a message received from the Body Control Module (BCM) on the Chrysler Collision Detection (CCD) data bus.

The BCM uses inputs from the parking brake switch and the brake warning switch to decide whether the brake warning lamp should be on or off. The BCM then sends the proper message to the instrument cluster on the CCD data bus to turn the lamp on or off.

The brake warning switch closes to ground when it senses unequal hydraulic pressures in the two halves of the split brake hydraulic system, possibly due to low brake fluid level or brake fluid leakage. The parking brake switch closes to ground when the parking brake is applied. Refer to Group 5 - Brakes for more information.

CHECK GAUGES LAMP

The check gauges lamp gives an indication when certain gauges reflect a condition requiring immediate attention. The lamp is turned on by the instrument cluster circuitry for about three seconds after the ignition switch is turned to the On position as a bulb test. After the bulb test, the lamp is controlled by the instrument cluster circuitry based upon gauge data messages received from either the Body Control Module (BCM) or the Powertrain Control Module (PCM) on the Chrysler Collision Detection (CCD) data bus.

The BCM and PCM use several inputs to decide whether a condition exists requiring the check gauges lamp to be turned on. The responsible module then sends the proper message to the instrument cluster on the CCD data bus to turn the lamp on or off. When the instrument cluster circuitry receives a check gauges lamp-on message, it sends a chime

DESCRIPTION AND OPERATION (Continued)

request message to the BCM on the CCD data bus for a chime tone to sound.

The gauge data messages for which the instrument cluster is programmed to turn on the check gauges lamp and the responsible modules are:

- Engine coolant temperature is high or critical (BCM)
- Engine oil pressure is low (BCM)
- Charging system failure (PCM)
- System voltage is high (PCM).

CLUSTER ILLUMINATION LAMP

When the park or head lamps are on, the cluster illumination lamps light. Illumination brightness is adjusted by sliding the panel dimmer switch knob (downwards to dim, upwards to brighten). Each of the instrument cluster illumination lamps receives pulse-width modulated battery feed from the Body Control Module (BCM) on the hard-wired panel lamps driver circuit. The BCM monitors the panel dimmer resistor switch to determine the desired dimming level, then adjusts the pulse-width signal accordingly.

The BCM also sends the proper panel lamps dimming level message on the Chrysler Collision Detection (CCD) data bus to control the dimming levels of the various vacuum fluorescent displays. All modules on the CCD data bus with vacuum fluorescent displays (instrument cluster, radio, mini trip computer, vehicle information center) receive this message and adjust their dimming levels to match that of the incandescent cluster illumination bulbs driven directly by the BCM.

Vehicles equipped with the automatic headlamps option have an automatic funeral mode or parade mode. In this mode, the BCM uses an input from the automatic headlamp light sensor to determine the ambient light levels. If the BCM decides that the exterior lighting is turned on in the daylight, it overrides the selected panel dimmer switch signal by sending a message on the CCD bus to illuminate all vacuum fluorescent displays at full brightness for easier visibility in daytime light levels. The automatic funeral mode or parade mode has no effect on the incandescent bulb dimming levels.

Each of the cluster illumination lamps is located on the instrument cluster circuit board. Each lamp has a replaceable bulb and bulb holder. Refer to Group 8L - Lamps for more information.

CRUISE-ON INDICATOR LAMP

The cruise-on indicator lamp gives an indication when the vehicle speed control system is turned on, even when the system is not currently engaged. The lamp is turned on by the instrument cluster circuitry for about four seconds when the ignition switch is

turned to the On position as a bulb test. After the bulb test, the lamp is controlled by the instrument cluster circuitry based upon a message received from the Powertrain Control Module (PCM) on the Chrysler Collision Detection (CCD) data bus.

The PCM uses an input from the analog resistor-multiplexed vehicle speed control switches in the steering wheel to decide whether to turn the lamp on or off. The PCM then sends the proper message to the instrument cluster on the CCD data bus. Refer to Group 8H - Vehicle Speed Control System for more information.

HEADLAMP HIGH BEAM INDICATOR LAMP

The headlamp high beam indicator lamp gives an indication when the headlamp high beams are turned on. The lamp is turned on by the instrument cluster circuitry for about four seconds when the ignition switch is turned to the On position as a bulb test. After the bulb test, the lamp is controlled by the instrument cluster circuitry based upon a message received from the Body Control Module (BCM) on the Chrysler Collision Detection (CCD) data bus.

The BCM uses an input from the headlamp dimmer (multi-function) switch to decide whether the headlamp high beams are turned on. It then sends the proper message to the instrument cluster on the CCD data bus to turn the lamp on or off. Refer to Group 8L - Lamps for more information.

LOW FUEL WARNING LAMP

The low fuel warning lamp gives an indication when the fuel level in the fuel tank has fallen below about one-eighth of a full tank, as registered on the fuel gauge. The instrument cluster circuitry lights the lamp for about four seconds when the ignition switch is turned to the On position as a bulb test. After the bulb test, the instrument cluster circuitry controls the lamp based upon a fuel level message received from the Body Control Module (BCM) on the Chrysler Collision Detection (CCD) data bus.

The BCM uses a fuel level message received from the Powertrain Control Module (PCM) on the CCD data bus to decide when the fuel level is low. The BCM then sends the proper message to the instrument cluster on the CCD data bus. When the lamp-on message is sent, the BCM also issues a single low fuel warning chime tone. Once the lamp is turned on, an increase in the fuel level of at least one-half gallon is required before the PCM input to the BCM will change and cause a lamp-off message to be issued. If the PCM detects a short or open in the fuel gauge sending unit circuit, it sends a message on the CCD data bus that will cause the fuel gauge pointer to move to the empty stop and the low fuel lamp to be turned on.

DESCRIPTION AND OPERATION (Continued)

Refer to Group 14 - Fuel Systems for more information on the PCM and its inputs.

MALFUNCTION INDICATOR LAMP

The Check Engine or Malfunction Indicator Lamp (MIL) gives an indication when the Powertrain Control Module (PCM) has recorded a Diagnostic Trouble Code (DTC) for an On-Board Diagnostics II (OBDII) emissions-related circuit or component malfunction. The lamp is turned on by the instrument cluster circuitry for about three seconds when the ignition switch is turned to the On position as a bulb test. After the bulb test, the lamp is controlled by the instrument cluster circuitry based upon messages received from the PCM on the Chrysler Collision Detection (CCD) data bus.

The PCM uses inputs from many emissions-related circuits and sensors, along with its internal programming, to decide whether a condition exists that requires the MIL lamp to be turned on. The PCM then sends the proper message to the instrument cluster on the CCD data bus to turn the lamp on or off. When the instrument cluster circuitry receives a MIL lamp-on message from the PCM, it sends a chime request message to the Body Control Module (BCM) on the CCD data bus for a single chime tone to sound.

The MIL lamp can also be used to display a stored DTC by flashing on and off. Refer to Group 14 - Fuel Systems for more information on the PCM or the PCM inputs. Refer to Group 25 - Emission Control Systems for more information on DTCs and their retrieval.

MASTER LIGHTING INDICATOR LAMP

Vehicles sold in countries where it is required equipment, have a master lighting indicator lamp. The master lighting indicator lamp gives an indication when the exterior lamps are lighted. The lamp is hard-wired in the instrument cluster, and is completely controlled by the panel lamps driver circuit.

The lamp is grounded at all times and receives a pulse-width modulated battery feed from the Body Control Module (BCM). The instrument cluster circuitry does not perform a bulb test for this lamp. Refer to Cluster Illumination Lamp in this group, or to Group 8L - Lamps for more information.

SEAT BELT REMINDER LAMP

The seat belt reminder lamp gives a visual reminder to the vehicle occupants to fasten their seat belts. The lamp is turned on by the instrument cluster circuitry for about seven seconds when the ignition switch is turned to the On position.

If the driver seat belt switch is closed (seat belt is not buckled), the Body Control Module (BCM) will

also sound a chime warning for the duration of the seat belt reminder lamp illumination. The chime warning will stop when the driver seat belt switch is open (seat belt is buckled).

The seat belt reminder lamp also serves as a backup for the airbag indicator lamp. Following the seat belt reminder lamp seven second display function, if the instrument cluster circuitry has detected an inoperative airbag indicator lamp circuit it will flash the seat belt reminder lamp on and off for twenty seconds. If the seat belt reminder lamp flashes longer than twenty seconds, or flashes at any time other than immediately after the initial seven second seat belt reminder lamp display, it indicates an airbag system fault has been detected and that the airbag indicator lamp is inoperative.

Refer to Group 8U - Chime/Buzzer Warning Systems for more information on the driver seat belt switch.

TURN SIGNAL INDICATOR LAMP

The left and right turn signal indicator lamps give an indication when the turn signal circuits are activated. The lamps are hard-wired in the instrument cluster, and are completely controlled by the turn signal and hazard warning (multi-function) switches.

The indicator lamps are grounded at all times and receive battery feed through the contacts of the multi-function switch when the turn signal lever (multi-function switch stalk) or the hazard warning button are actuated to their On positions. The instrument cluster circuitry does not perform a bulb test of these lamps. Refer to Group 8J - Turn Signal and Hazard Warning Systems for more information.

UPSHIFT INDICATOR LAMP

Vehicles equipped with a manual transmission have an upshift indicator lamp. The upshift indicator lamp gives an indication when the driver should shift to the next highest gear for the best fuel economy. The lamp is turned on by the instrument cluster circuitry for about three seconds when the ignition switch is turned to the On position as a bulb test. After the bulb test, the lamp is controlled by the instrument cluster circuitry based upon a message received from the Powertrain Control Module (PCM) on the Chrysler Collision Detection (CCD) data bus.

The PCM uses inputs from many sensors and its internal programming to decide whether the engine speed and load conditions are proper for a transmission upshift. The PCM then sends the proper message to the instrument cluster on the CCD data bus to turn the lamp on or off. The PCM will send a lamp-off message three to five seconds after a lamp-on message, if an upshift is not performed. The lamp will then remain off until the vehicle stops

DESCRIPTION AND OPERATION (Continued)

accelerating and is brought back into the range of lamp operation, or until the transmission is shifted into another gear. Refer to Group 14 - Fuel Systems for more information on the PCM and the PCM inputs.

WAIT-TO-START LAMP

Vehicles equipped with an optional diesel engine have a wait-to-start lamp. The wait-to-start lamp gives an indication that the conditions for easiest starting of the diesel engine have not yet been achieved. The lamp is turned on by the instrument cluster circuitry for about four seconds when the ignition switch is turned to the On position as a bulb test. After the bulb test, the lamp is controlled by the instrument cluster circuitry based upon a message received from the Powertrain Control Module (PCM) on the Chrysler Collision Detection (CCD) data bus.

The PCM uses inputs from many sensors and its internal programming to determine whether the proper conditions exist for easiest diesel engine starting. The PCM then sends the proper message to the instrument cluster on the CCD data bus to turn the lamp on or off. Refer to Group 14 - Fuel Systems for more information on the PCM and the PCM inputs.

WATER-IN-FUEL LAMP

Vehicles equipped with an optional diesel engine have a water-in-fuel lamp. The water-in-fuel lamp gives an indication when the water contamination in the diesel fuel exceeds a certain level. The lamp is turned on by the instrument cluster circuitry for about three seconds when the ignition switch is turned to the On position as a bulb test. After the bulb test, the lamp is controlled by the instrument cluster circuitry based upon a message received from the Powertrain Control Module (PCM) on the Chrysler Collision Detection (CCD) data bus.

The PCM uses an input from the water-in-fuel sensor in the fuel filter/water separator to determine that excess water has accumulated in the diesel fuel. The PCM then sends the proper message to the instrument cluster on the CCD data bus to turn the lamp on or off. Refer to Group 14 - Fuel Systems for more information.

DIAGNOSIS AND TESTING

INSTRUMENT CLUSTER

All of the gauges and many of the indicator lamps in the instrument cluster are controlled by messages received by the instrument cluster circuitry on the CCD data bus. Only the cluster illumination lamps, anti-lock brake system lamp, turn signal indicator lamps, and the master lighting indicator lamp (if the

vehicle is so equipped) are hard-wired in the gauge cluster.

If an individual gauge or lamp is inoperative, see the diagnostic procedure under the heading for that gauge or lamp. For circuit descriptions and diagrams, refer to 8W-40 - Instrument Cluster in Group 8W - Wiring Diagrams. If more than one gauge or lamp is inoperative, perform the following:

WARNING: ON VEHICLES EQUIPPED WITH AIR-BAGS, REFER TO GROUP 8M - PASSIVE RESTRAINT SYSTEMS BEFORE ATTEMPTING ANY STEERING WHEEL, STEERING COLUMN, OR INSTRUMENT PANEL COMPONENT DIAGNOSIS OR SERVICE. FAILURE TO TAKE THE PROPER PRECAUTIONS COULD RESULT IN ACCIDENTAL AIR-BAG DEPLOYMENT AND POSSIBLE PERSONAL INJURY.

(1) Check the fuses in the junction block module. If OK, go to Step 2. If not OK, repair the shorted circuit or component as required and replace the faulty fuse.

(2) Check for battery voltage at the fused B+ fuse in the junction block. If OK, go to Step 3. If not OK, repair the open circuit to the fuse in the Power Distribution Center (PDC) as required.

(3) Turn the ignition switch to the On position. Check for battery voltage at the fused ignition switch output (start/run) fuse in the junction block. If OK, go to Step 4. If not OK, repair the open circuit to the fuse in the Power Distribution Center (PDC) as required.

(4) Turn the ignition switch to the Off position. Disconnect and isolate the battery negative cable. Remove the instrument cluster as described in this group. Connect the battery negative cable. Check for battery voltage at the fused B(+) circuit cavity of the instrument cluster wire harness connector. If OK, go to Step 5. If not OK, repair the open circuit from the fuse in the junction block as required.

(5) Turn the ignition switch to the On position. Check for battery voltage at the fused ignition switch output (start/run) circuit cavity of the instrument cluster wire harness connector. If OK, go to Step 6. If not OK, repair the open circuit from the fuse in the junction block as required.

(6) Turn the ignition switch to the Off position. Disconnect and isolate the battery negative cable. Probe each of the ground circuit cavities of the instrument cluster wire harness connector. Check for continuity to a good ground. There should be continuity. If OK, refer to the proper Diagnostic Procedures manual for further testing of the instrument cluster circuitry and the CCD data bus with a DRB scan tool. If not OK, repair the open circuit(s) to ground as required.

DIAGNOSIS AND TESTING (Continued)

COOLANT TEMPERATURE GAUGE

If the problem being diagnosed is related to coolant temperature gauge accuracy, be certain to confirm that the problem is with the gauge and not with cooling system performance. The actual engine coolant temperature should be checked with a test gauge or thermometer and compared to the instrument cluster coolant temperature gauge readings before you proceed with gauge diagnosis. Refer to Group 7 - Cooling System for more information. Refer to Group 8W - Wiring Diagrams for circuit descriptions and diagrams.

WARNING: ON VEHICLES EQUIPPED WITH AIR-BAGS, REFER TO GROUP 8M - PASSIVE RESTRAINT SYSTEMS BEFORE ATTEMPTING ANY STEERING WHEEL, STEERING COLUMN, OR INSTRUMENT PANEL COMPONENT DIAGNOSIS OR SERVICE. FAILURE TO TAKE THE PROPER PRECAUTIONS COULD RESULT IN ACCIDENTAL AIR-BAG DEPLOYMENT AND POSSIBLE PERSONAL INJURY.

Diagnosis of the coolant temperature sensor and circuit, the Chrysler Collision Detection (CCD) data bus, and/or the Powertrain Control Module (PCM) should be performed with a DRB scan tool as described in the proper Diagnostic Procedures manual. For further diagnosis of the coolant temperature gauge and the instrument cluster circuitry, see Instrument Cluster in this group.

FUEL GAUGE

If the problem being diagnosed is related to fuel gauge accuracy, be certain to confirm that the problem is with the gauge or sending unit and not with the fuel tank. Inspect the fuel tank for signs of damage or distortion that could affect the sending unit performance before you proceed with fuel gauge diagnosis. Refer to Group 8W - Wiring Diagrams for circuit descriptions and diagrams.

WARNING: ON VEHICLES EQUIPPED WITH AIR-BAGS, REFER TO GROUP 8M - PASSIVE RESTRAINT SYSTEMS BEFORE ATTEMPTING ANY STEERING WHEEL, STEERING COLUMN, OR INSTRUMENT PANEL COMPONENT DIAGNOSIS OR SERVICE. FAILURE TO TAKE THE PROPER PRECAUTIONS COULD RESULT IN ACCIDENTAL AIR-BAG DEPLOYMENT AND POSSIBLE PERSONAL INJURY.

Diagnosis of the fuel gauge sending unit and circuit, the Chrysler Collision Detection (CCD) data bus, and/or the Powertrain Control Module (PCM) should be performed with a DRB scan tool as described in the proper Diagnostic Procedures man-

ual. For further diagnosis of the fuel gauge and the instrument cluster circuitry, see Instrument Cluster in this group.

ODOMETER AND TRIP ODOMETER

If the problem being diagnosed is related to odometer and/or trip odometer accuracy, be certain to confirm that the problem is with the display and not with an incorrect speedometer pinion gear, axle ratio, or tire size. Refer to Group 21 - Transmission for more information on the speedometer pinion gear. Refer to Group 8W - Wiring Diagrams for circuit descriptions and diagrams.

WARNING: ON VEHICLES EQUIPPED WITH AIR-BAGS, REFER TO GROUP 8M - PASSIVE RESTRAINT SYSTEMS BEFORE ATTEMPTING ANY STEERING WHEEL, STEERING COLUMN, OR INSTRUMENT PANEL COMPONENT DIAGNOSIS OR SERVICE. FAILURE TO TAKE THE PROPER PRECAUTIONS COULD RESULT IN ACCIDENTAL AIR-BAG DEPLOYMENT AND POSSIBLE PERSONAL INJURY.

Diagnosis of the vehicle speed sensor and circuit, the Chrysler Collision Detection (CCD) data bus, the Body Control Module (BCM) and/or the Powertrain Control Module (PCM) should be performed with a DRB scan tool as described in the proper Diagnostic Procedures manual. For further diagnosis of the odometer and/or trip odometer and the instrument cluster circuitry, see Instrument Cluster in this group.

OIL PRESSURE GAUGE

If the problem being diagnosed is related to oil pressure gauge accuracy, be certain to confirm that the problem is with the gauge and not with the engine oiling system performance. The actual engine oil pressure should be checked with a test gauge and compared to the instrument cluster oil pressure gauge readings before you proceed with gauge diagnosis. Refer to Group 9 - Engines for more information. Refer to Group 8W - Wiring Diagrams for circuit descriptions and diagrams.

WARNING: ON VEHICLES EQUIPPED WITH AIR-BAGS, REFER TO GROUP 8M - PASSIVE RESTRAINT SYSTEMS BEFORE ATTEMPTING ANY STEERING WHEEL, STEERING COLUMN, OR INSTRUMENT PANEL COMPONENT DIAGNOSIS OR SERVICE. FAILURE TO TAKE THE PROPER PRECAUTIONS COULD RESULT IN ACCIDENTAL AIR-BAG DEPLOYMENT AND POSSIBLE PERSONAL INJURY.

DIAGNOSIS AND TESTING (Continued)

Diagnosis of the oil pressure sensor and circuit, the Chrysler Collision Detection (CCD) data bus, and/or the Powertrain Control Module (PCM) should be performed with a DRB scan tool as described in the proper Diagnostic Procedures manual. For further diagnosis of the oil pressure gauge and the instrument cluster circuitry, see Instrument Cluster in this group.

SPEEDOMETER

If the problem being diagnosed is related to speedometer accuracy, be certain to confirm that the problem is with the speedometer gauge and not with an incorrect speedometer pinion gear, axle ratio, or tire size. Refer to Group 21 - Transmission for more information on the speedometer pinion gear. Refer to Group 8W - Wiring Diagrams for circuit descriptions and diagrams.

WARNING: ON VEHICLES EQUIPPED WITH AIRBAGS, REFER TO GROUP 8M - PASSIVE RESTRAINT SYSTEMS BEFORE ATTEMPTING ANY STEERING WHEEL, STEERING COLUMN, OR INSTRUMENT PANEL COMPONENT DIAGNOSIS OR SERVICE. FAILURE TO TAKE THE PROPER PRECAUTIONS COULD RESULT IN ACCIDENTAL AIRBAG DEPLOYMENT AND POSSIBLE PERSONAL INJURY.

Diagnosis of the vehicle speed sensor and circuit, the Chrysler Collision Detection (CCD) data bus, and/or the Powertrain Control Module (PCM) should be performed with a DRB scan tool as described in the proper Diagnostic Procedures manual. For further diagnosis of the speedometer and the instrument cluster circuitry, see Instrument Cluster in this group.

TACHOMETER

WARNING: ON VEHICLES EQUIPPED WITH AIRBAGS, REFER TO GROUP 8M - PASSIVE RESTRAINT SYSTEMS BEFORE ATTEMPTING ANY STEERING WHEEL, STEERING COLUMN, OR INSTRUMENT PANEL COMPONENT DIAGNOSIS OR SERVICE. FAILURE TO TAKE THE PROPER PRECAUTIONS COULD RESULT IN ACCIDENTAL AIRBAG DEPLOYMENT AND POSSIBLE PERSONAL INJURY.

Refer to Group 8W - Wiring Diagrams for circuit descriptions and diagrams. Diagnosis of the crankshaft position sensor and circuit, the Chrysler Collision Detection (CCD) data bus, and/or the Powertrain Control Module (PCM) should be performed with a DRB scan tool as described in the proper Diagnostic Procedures manual. For further diagnosis of the

tachometer and the instrument cluster circuitry, see Instrument Cluster in this group.

VOLTMETER

If the problem being diagnosed is related to voltmeter gauge accuracy, be certain to confirm proper charging system operation before considering gauge replacement. Refer to Group 8C - Charging System for more information. Refer to Group 8W - Wiring Diagrams for circuit descriptions and diagrams.

WARNING: ON VEHICLES EQUIPPED WITH AIRBAGS, REFER TO GROUP 8M - PASSIVE RESTRAINT SYSTEMS BEFORE ATTEMPTING ANY STEERING WHEEL, STEERING COLUMN, OR INSTRUMENT PANEL COMPONENT DIAGNOSIS OR SERVICE. FAILURE TO TAKE THE PROPER PRECAUTIONS COULD RESULT IN ACCIDENTAL AIRBAG DEPLOYMENT AND POSSIBLE PERSONAL INJURY.

Diagnosis of the system voltage input circuit, the Chrysler Collision Detection (CCD) data bus, and/or the Powertrain Control Module (PCM) should be performed with a DRB scan tool as described in the proper Diagnostic Procedures manual. For further diagnosis of the voltmeter and the instrument cluster circuitry, see Instrument Cluster in this group.

AIRBAG INDICATOR LAMP

The diagnosis found here addresses an inoperative airbag indicator lamp condition. If the airbag indicator lamp stays on with the ignition switch in the On position, or comes on and stays on while driving, refer to Group 8M - Passive Restraint Systems for diagnosis. For circuit descriptions and diagrams, refer to 8W-40 - Instrument Cluster, 8W-43 - Airbag System, and 8W-45 - Body Control Module in Group 8W - Wiring Diagrams.

WARNING: ON VEHICLES EQUIPPED WITH AIRBAGS, REFER TO GROUP 8M - PASSIVE RESTRAINT SYSTEMS BEFORE ATTEMPTING ANY STEERING WHEEL, STEERING COLUMN, OR INSTRUMENT PANEL COMPONENT DIAGNOSIS OR SERVICE. FAILURE TO TAKE THE PROPER PRECAUTIONS COULD RESULT IN ACCIDENTAL AIRBAG DEPLOYMENT AND POSSIBLE PERSONAL INJURY.

The airbag indicator lamp has a lamp backup feature. Following the seat belt reminder lamp display function, if the instrument cluster circuitry has detected an inoperative airbag warning lamp circuit it will flash the seat belt reminder lamp on and off for twenty seconds. Once the instrument cluster circuitry has detected an inoperative airbag warning

DIAGNOSIS AND TESTING (Continued)

lamp circuit, if a lamp-on message is received from the Airbag Control Module (ACM) on the Chrysler Collision Detection (CCD) data bus, the seatbelt reminder lamp will flash for twelve seconds or the duration of the airbag system malfunction, whichever is longer.

If the airbag indicator lamp fails to light when the ignition switch is turned to the On position, and the seat belt reminder lamp flashes following its normal display function (about seven seconds after the ignition switch is turned to the On position), replace the airbag indicator lamp bulb with a known good unit. If the airbag indicator lamp still fails to operate, diagnosis of the airbag lamp, the instrument cluster circuitry, the CCD data bus, and the Body Control Module (BCM) should be performed with a DRB scan tool as described in the proper Diagnostic Procedures manual. For further diagnosis of the airbag indicator lamp and the instrument cluster circuitry, see Instrument Cluster in this group.

ANTI-LOCK BRAKE SYSTEM LAMP

The diagnosis found here addresses an inoperative Anti-lock Brake System (ABS) lamp condition. If the ABS lamp stays on with the ignition switch in the On position, or comes on and stays on while driving, refer to Group 5 - Brakes for diagnosis. If no ABS problem is found, the following procedure will help locate a short or open in the ABS lamp circuit. For circuit descriptions and diagrams, refer to 8W-40 - Instrument Cluster, and 8W-35 - All-Wheel Anti-Lock Brakes in Group 8W - Wiring Diagrams.

WARNING: ON VEHICLES EQUIPPED WITH AIRBAGS, REFER TO GROUP 8M - PASSIVE RESTRAINT SYSTEMS BEFORE ATTEMPTING ANY STEERING WHEEL, STEERING COLUMN, OR INSTRUMENT PANEL COMPONENT DIAGNOSIS OR SERVICE. FAILURE TO TAKE THE PROPER PRECAUTIONS COULD RESULT IN ACCIDENTAL AIRBAG DEPLOYMENT AND POSSIBLE PERSONAL INJURY.

(1) Check the fuse in the junction block. If OK, go to Step 2. If not OK, repair the shorted circuit or component as required and replace the faulty fuse.

(2) Turn the ignition switch to the On position. Check for battery voltage at the fuse in the junction block. If OK, go to Step 3. If not OK, repair the open circuit to the ignition switch as required.

(3) Turn the ignition switch to the Off position. Disconnect and isolate the battery negative cable. Remove the instrument cluster. Connect the battery negative cable. Turn the ignition switch to the On position and within five seconds check for battery voltage between the fused ignition switch output circuit and the ABS warning lamp driver circuit cavities

of the instrument cluster wire harness connector. If OK, replace the faulty bulb. If not OK, go to Step 4.

(4) Turn the ignition switch to the Off position. Disconnect and isolate the battery negative cable. Unplug the Controller Anti-lock Brake (CAB) wire harness connector. Check for continuity between the ABS warning lamp driver circuit cavity of the instrument cluster wire harness connector and a good ground. There should be no continuity. If OK, go to Step 5. If not OK, repair the short circuit as required.

(5) Check for continuity between the ABS warning lamp driver circuit cavities of the instrument cluster wire harness connector and the CAB wire harness connector. There should be continuity. If OK, refer to Group 5 - Brakes for diagnosis of the CAB. If not OK, repair the open circuit as required.

BRAKE WARNING LAMP

The diagnosis found here addresses an inoperative brake warning lamp condition. If the brake warning lamp stays on with the ignition switch in the On position and the parking brake released, or comes on while driving, refer to Group 5 - Brakes for diagnosis. If no service brake or parking brake problem is found, proceed as follows. Refer to 8W-40 - Instrument Cluster, 8W-35 - All-Wheel Anti-Lock Brakes, and 8W-45 - Body Control Module in Group 8W - Wiring Diagrams for circuit descriptions and diagrams.

WARNING: ON VEHICLES EQUIPPED WITH AIRBAGS, REFER TO GROUP 8M - PASSIVE RESTRAINT SYSTEMS BEFORE ATTEMPTING ANY STEERING WHEEL, STEERING COLUMN, OR INSTRUMENT PANEL COMPONENT DIAGNOSIS OR SERVICE. FAILURE TO TAKE THE PROPER PRECAUTIONS COULD RESULT IN ACCIDENTAL AIRBAG DEPLOYMENT AND POSSIBLE PERSONAL INJURY.

If the brake warning lamp fails to light during the bulb test (for about four seconds after the ignition switch is turned to the On position), replace the bulb with a known good unit. If the brake warning lamp still fails to operate, diagnosis of the park brake switch and circuit, the brake warning switch and circuit, the Body Control Module (BCM), the instrument cluster circuitry, and/or the CCD data bus should be performed with a DRB scan tool as described in the proper Diagnostic Procedures manual. For further diagnosis of the brake warning lamp and the instrument cluster circuitry, see Instrument Cluster in this group.

DIAGNOSIS AND TESTING (Continued)**CHECK GAUGES LAMP**

The diagnosis found here addresses an inoperative check gauges lamp condition. If the check gauges lamp stays on with the ignition switch in the On position, or comes on while driving with no unusual gauge readings evident, diagnosis of the Powertrain Control Module (PCM), Body Control Module (BCM) and the Chrysler Collision Detection (CCD) data bus should be performed with a DRB scan tool as described in the proper Diagnostic Procedures manual. For circuit descriptions and diagrams, refer to 8W-30 - Fuel/Ignition Systems, 8W-40 - Instrument Cluster, and 8W-45 - Body Control Module in Group 8W - Wiring Diagrams.

WARNING: ON VEHICLES EQUIPPED WITH AIR-BAGS, REFER TO GROUP 8M - PASSIVE RESTRAINT SYSTEMS BEFORE ATTEMPTING ANY STEERING WHEEL, STEERING COLUMN, OR INSTRUMENT PANEL COMPONENT DIAGNOSIS OR SERVICE. FAILURE TO TAKE THE PROPER PRECAUTIONS COULD RESULT IN ACCIDENTAL AIR-BAG DEPLOYMENT AND POSSIBLE PERSONAL INJURY.

If the check gauges lamp fails to light during the bulb test (about three seconds after the ignition switch is turned to the On position), replace the check gauges lamp bulb with a known good unit. If the check gauges lamp still fails to operate, diagnosis of the lamp, the instrument cluster circuitry, the CCD data bus, the BCM and the PCM should be performed with a DRB scan tool as described in the proper Diagnostic Procedures manual. For further diagnosis of the check gauges lamp and the instrument cluster circuitry, see Instrument Cluster in this group.

CLUSTER ILLUMINATION LAMP

The diagnosis found here addresses an inoperative instrument cluster illumination lamp condition. If the problem being diagnosed is related to the dimming level of the instrument cluster illumination lamps, diagnosis should be performed with a DRB scan tool as described in the proper Diagnostic Procedures manual. For circuit descriptions and diagrams, refer to 8W-40 - Instrument Cluster, 8W-45 - Body Control Module, and/or 8W-50 - Front Lighting in Group 8W - Wiring Diagrams.

WARNING: ON VEHICLES EQUIPPED WITH AIR-BAGS, REFER TO GROUP 8M - PASSIVE RESTRAINT SYSTEMS BEFORE ATTEMPTING ANY STEERING WHEEL, STEERING COLUMN, OR INSTRUMENT PANEL COMPONENT DIAGNOSIS OR SERVICE. FAILURE TO TAKE THE PROPER PRECAUTIONS COULD RESULT IN ACCIDENTAL AIR-

BAG DEPLOYMENT AND POSSIBLE PERSONAL INJURY.

If only individual instrument cluster illumination lamps are inoperative, replace the faulty bulbs. If all of the instrument cluster illumination lamps are inoperative, proceed as follows.

(1) Disconnect and isolate the battery negative cable. Remove the instrument cluster. Connect the battery negative cable. Turn the park lamps on with the headlamp switch. Adjust the panel lamp dimmer switch knob to its highest level (fully upwards). Check for voltage at the panel lamp driver circuit cavity of the instrument cluster wire harness connector. If OK, replace the faulty instrument cluster. If not OK, go to Step 2.

(2) Disconnect and isolate the battery negative cable. Unplug the white 24-way Body Control Module (BCM) wire harness connector. Check for continuity between the panel lamp driver circuit cavities of the instrument cluster wire harness connector and the BCM wire harness connector. If OK, refer to Group 8L - Lamps for diagnosis of the headlamp switch and/or the proper Diagnostic Procedures manual for diagnosis of the BCM. If not OK, repair the open circuit as required.

CRUISE-ON INDICATOR LAMP

The diagnosis found here addresses an inoperative cruise-on indicator lamp condition. If the problem being diagnosed is an inaccurate cruise-on indicator lamp, refer to Group 8H - Vehicle Speed Control for diagnosis of the vehicle speed control system. For circuit descriptions and diagrams, refer to 8W-33 - Vehicle Speed Control and 8W-40 - Instrument Cluster in Group 8W - Wiring Diagrams.

WARNING: ON VEHICLES EQUIPPED WITH AIR-BAGS, REFER TO GROUP 8M - PASSIVE RESTRAINT SYSTEMS BEFORE ATTEMPTING ANY STEERING WHEEL, STEERING COLUMN, OR INSTRUMENT PANEL COMPONENT DIAGNOSIS OR SERVICE. FAILURE TO TAKE THE PROPER PRECAUTIONS COULD RESULT IN ACCIDENTAL AIR-BAG DEPLOYMENT AND POSSIBLE PERSONAL INJURY.

If the cruise-on indicator lamp fails to light during the bulb test (about four seconds after the ignition switch is turned to the On position), replace the cruise-on indicator lamp bulb with a known good unit. If the cruise-on lamp still fails to operate, diagnosis of the lamp, the instrument cluster circuitry, the vehicle speed control switches, the Powertrain Control Module (PCM) and the CCD data bus should be performed with a DRB scan tool as described in the proper Diagnostic Procedures manual. For fur-

DIAGNOSIS AND TESTING (Continued)

ther diagnosis of the cruise-on indicator lamp and the instrument cluster circuitry, see Instrument Cluster in this group.

GRAPHIC DISPLAY MODULE

If the problem being diagnosed is related to Graphic Display Module (GDM) illumination, see the GDM Illumination diagnosis below. If the problem being diagnosed is related to the four-wheel drive display or the four-wheel drive message lamps, see the Four-Wheel Drive Indicator Lamp diagnosis below. Refer to 8W-46 - Message Center in Group 8W - Wiring Diagrams for complete circuit descriptions and diagrams.

GDM ILLUMINATION

The diagnosis found here addresses an inoperative graphic display module illumination lamp condition. If the problem being diagnosed is related to the dimming level of the illumination lamps, diagnosis should be performed with a DRB scan tool as described in the proper Diagnostic Procedures manual.

WARNING: ON VEHICLES EQUIPPED WITH AIRBAGS, REFER TO GROUP 8M - PASSIVE RESTRAINT SYSTEMS BEFORE ATTEMPTING ANY STEERING WHEEL, STEERING COLUMN, OR INSTRUMENT PANEL COMPONENT DIAGNOSIS OR SERVICE. FAILURE TO TAKE THE PROPER PRECAUTIONS COULD RESULT IN ACCIDENTAL AIRBAG DEPLOYMENT AND POSSIBLE PERSONAL INJURY.

If only individual illumination lamps are inoperative, replace the faulty bulbs. If all of the illumination lamps are inoperative, proceed as follows.

(1) Disconnect and isolate the battery negative cable. Remove the GDM from the instrument panel. Unplug the GDM wire harness connector. Connect the battery negative cable.

(2) Turn the park lamps on with the headlamp switch. Adjust the panel lamp dimmer switch knob to its highest level (fully upwards). Check for voltage at the panel lamp driver circuit cavity of the GDM wire harness connector. If OK, replace the faulty GDM. If not OK, go to Step 3.

(3) Disconnect and isolate the battery negative cable. Unplug the white 24-way Body Control Module (BCM) wire harness connector. Check for continuity between the panel lamp driver circuit cavities of the GDM wire harness connector and the BCM wire harness connector. If OK, refer to Group 8L - Lamps for diagnosis of the headlamp switch and/or the proper Diagnostic Procedures manual for diagnosis of the BCM. If not OK, repair the open circuit as required.

FOUR-WHEEL DRIVE INDICATOR LAMP

WARNING: ON VEHICLES EQUIPPED WITH AIRBAGS, REFER TO GROUP 8M - PASSIVE RESTRAINT SYSTEMS BEFORE ATTEMPTING ANY STEERING WHEEL, STEERING COLUMN, OR INSTRUMENT PANEL COMPONENT DIAGNOSIS OR SERVICE. FAILURE TO TAKE THE PROPER PRECAUTIONS COULD RESULT IN ACCIDENTAL AIRBAG DEPLOYMENT AND POSSIBLE PERSONAL INJURY.

(1) Unplug the wire harness connector at the transfer case switch. Check for continuity between the ground circuit cavity of the transfer case switch wire harness connector and a good ground. There should be continuity. If OK, go to Step 2. If not OK, repair the open circuit as required.

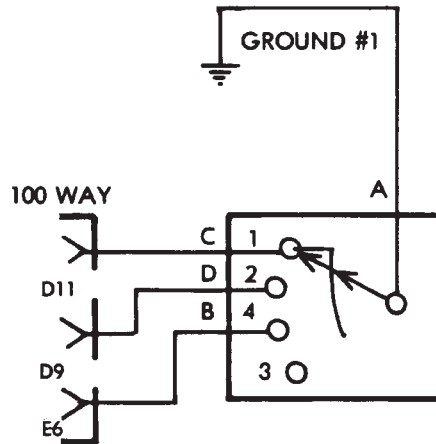
(2) Check the transfer case switch continuity while shifting the transfer case shift lever to the proper positions. The switch continuity should be as shown in (Fig. 1). If OK, go to Step 3. If not OK, replace the faulty switch.

(3) Disconnect and isolate the battery negative cable. Remove the GDM from the instrument panel. Unplug the GDM wire harness connector.

(4) Check for continuity in the circuit for the indicator lamp or wheel lamp that is not functioning between the GDM wire harness connector and the transfer case switch wire harness connector. There should be continuity. If OK, go to Step 5. If not OK, repair the open circuit as required.

(5) Replace the bulb for the inoperative indicator lamp or wheel lamp. Plug in the GDM and transfer case wire harness connectors. Connect the battery negative cable and check the operation of the inoperative lamp. If OK, discard the faulty bulb. If not OK, replace the faulty GDM.

DIAGNOSIS AND TESTING (Continued)



231 TRANSFER CASE (COMMAND-TRAC)

T/C POSITION	SWITCH POSITION
2WD	1
4 PART TIME	2
N	3
4 LO	2

242 TRANSFER CASE (SELEC-TRAC)

T/C POSITION	SWITCH POSITION
2WD	1
4 PART TIME	2
4 FULL TIME	4
N	3
4 LO	2

249 TRANSFER CASE (QUADRA-TRAC)

T/C POSITION	SWITCH POSITION
4 ALL TIME	1
N	3
4 LO	2

J948E-63

Fig. 1 Transfer Case Switch

HEADLAMP HIGH BEAM INDICATOR LAMP

The diagnosis found here addresses an inoperative headlamp high beam indicator lamp condition. If the problem being diagnosed is related to inoperative headlamp high beams, refer to Group 8L - Lamps for diagnosis of the headlamp system. If no headlamp system problems are found, proceed as follows. For circuit descriptions and diagrams, refer to 8W-40 - Instrument Cluster in Group 8W - Wiring Diagrams.

WARNING: ON VEHICLES EQUIPPED WITH AIR-BAGS, REFER TO GROUP 8M - PASSIVE RESTRAINT SYSTEMS BEFORE ATTEMPTING ANY STEERING WHEEL, STEERING COLUMN, OR INSTRUMENT PANEL COMPONENT DIAGNOSIS OR SERVICE. FAILURE TO TAKE THE PROPER PRECAUTIONS COULD RESULT IN ACCIDENTAL AIR-BAG DEPLOYMENT AND POSSIBLE PERSONAL INJURY.

If the headlamp high beam indicator lamp fails to light during the bulb test (about four seconds after the ignition switch is turned to the On position), replace the headlamp high beam indicator lamp bulb with a known good unit. If the indicator lamp still fails to operate, diagnosis of the lamp, the instrument cluster circuitry, the Chrysler Collision Detec-

tion (CCD) data bus, or the Body Control Module (BCM) should be performed with a DRB scan tool as described in the proper Diagnostic Procedures manual. For further diagnosis of the headlamp high beam indicator lamp and the instrument cluster circuitry, see Instrument Cluster in this group.

LOW FUEL WARNING LAMP

The diagnosis found here addresses an inoperative low fuel warning lamp condition. If the problem being diagnosed is related to lamp accuracy, be certain to confirm the problem is the with the low fuel warning lamp and not with the fuel gauge circuit. See the diagnosis for the Fuel Gauge in this group. If no fuel gauge problem is found, the following procedure will help to identify a faulty low fuel warning lamp circuit. For circuit descriptions and diagrams, refer to 8W-40 - Instrument Cluster in Group 8W - Wiring Diagrams.

DIAGNOSIS AND TESTING (Continued)

WARNING: ON VEHICLES EQUIPPED WITH AIR-BAGS, REFER TO GROUP 8M - PASSIVE RESTRAINT SYSTEMS BEFORE ATTEMPTING ANY STEERING WHEEL, STEERING COLUMN, OR INSTRUMENT PANEL COMPONENT DIAGNOSIS OR SERVICE. FAILURE TO TAKE THE PROPER PRECAUTIONS COULD RESULT IN ACCIDENTAL AIR-BAG DEPLOYMENT AND POSSIBLE PERSONAL INJURY.

If the low fuel warning lamp fails to light during the bulb test (about four seconds after the ignition switch is turned to the On position), replace the low fuel warning lamp bulb with a known good unit. If the indicator lamp still fails to operate, diagnosis of the lamp, the instrument cluster circuitry, the fuel gauge sending unit and circuit, the Powertrain Control Module (PCM), the Chrysler Collision Detection (CCD) data bus, or the Body Control Module (BCM) should be performed with a DRB scan tool as described in the proper Diagnostic Procedures manual. For further diagnosis of the low fuel warning lamp and the instrument cluster circuitry, see Instrument Cluster in this group.

MALFUNCTION INDICATOR LAMP

The diagnosis found here addresses an inoperative malfunction indicator (Check Engine) lamp condition. If the lamp comes on and stays on with the engine running, refer to Group 14 - Fuel Systems for diagnosis. For circuit descriptions and diagrams, refer to 8W-40 - Instrument Cluster in Group 8W - Wiring Diagrams.

WARNING: ON VEHICLES EQUIPPED WITH AIR-BAGS, REFER TO GROUP 8M - PASSIVE RESTRAINT SYSTEMS BEFORE ATTEMPTING ANY STEERING WHEEL, STEERING COLUMN, OR INSTRUMENT PANEL COMPONENT DIAGNOSIS OR SERVICE. FAILURE TO TAKE THE PROPER PRECAUTIONS COULD RESULT IN ACCIDENTAL AIR-BAG DEPLOYMENT AND POSSIBLE PERSONAL INJURY.

If the malfunction indicator lamp fails to light during the bulb test (about three seconds after the ignition switch is turned to the On position), replace the malfunction indicator lamp bulb with a known good unit. If the indicator lamp still fails to operate, diagnosis of the lamp, the instrument cluster circuitry, the Powertrain Control Module (PCM) or the Chrysler Collision Detection (CCD) data bus should be performed with a DRB scan tool as described in the proper Diagnostic Procedures manual. For further diagnosis of the malfunction indicator lamp and the instrument cluster circuitry, see Instrument Cluster in this group.

MASTER LIGHTING INDICATOR LAMP

The master lighting indicator shares the same circuitry as the cluster illumination lamps, and will brighten and dim when the panel lamp dimmer switch is adjusted. The diagnosis found here addresses an inoperative master lighting indicator lamp condition. If the problem being diagnosed is related to the dimming level of the master lighting indicator lamp, diagnosis should be performed with a DRB scan tool as described in the proper Body Diagnostic Procedures manual. For circuit descriptions and diagrams, refer to 8W-40 - Instrument Cluster, 8W-45 - Body Control Module, and/or 8W-50 - Front Lighting in Group 8W - Wiring Diagrams.

WARNING: ON VEHICLES EQUIPPED WITH AIR-BAGS, REFER TO GROUP 8M - PASSIVE RESTRAINT SYSTEMS BEFORE ATTEMPTING STEERING WHEEL, STEERING COLUMN, OR INSTRUMENT PANEL COMPONENT DIAGNOSIS OR SERVICE. FAILURE TO TAKE THE PROPER PRECAUTIONS COULD RESULT IN ACCIDENTAL AIR-BAG DEPLOYMENT AND POSSIBLE PERSONAL INJURY.

If only the master lighting indicator lamp is inoperative, replace the faulty bulb. If all of the cluster illumination lamps are inoperative, proceed as follows.

(1) Disconnect and isolate the battery negative cable. Remove the cluster bezel and the cluster assembly as described in this group.

(2) Connect the battery negative cable and turn the park lamps on with the headlamp switch. Adjust the panel lamp dimmer switch knob to its highest level (fully upwards). Check for voltage at the panel lamp driver circuit cavity of the cluster wire harness connector. If OK, replace the faulty instrument cluster. If not OK, go to Step 3.

(3) Disconnect and isolate the battery negative cable. Unplug the white 24-way Body Control Module (BCM) wire harness connector. Check for continuity between the panel lamp driver circuit cavities of the cluster wire harness connector and the BCM wire harness connector. If OK, refer to Group 8L - Lamps for diagnosis of the headlamp switch and/or the proper Body Diagnostic Procedures manual for diagnosis of the BCM. If not OK, repair the open circuit as required.

SEAT BELT REMINDER LAMP

The diagnosis found here addresses an inoperative seat belt reminder lamp condition. If the lamp comes on and flashes following its display function (for about seven seconds after the ignition switch is turned to the On position), see the diagnosis for the airbag indicator lamp in this group. For circuit

DIAGNOSIS AND TESTING (Continued)

descriptions and diagrams, refer to 8W-40 - Instrument Cluster in Group 8W - Wiring Diagrams.

WARNING: ON VEHICLES EQUIPPED WITH AIR-BAGS, REFER TO GROUP 8M - PASSIVE RESTRAINT SYSTEMS BEFORE ATTEMPTING ANY STEERING WHEEL, STEERING COLUMN, OR INSTRUMENT PANEL COMPONENT DIAGNOSIS OR SERVICE. FAILURE TO TAKE THE PROPER PRECAUTIONS COULD RESULT IN ACCIDENTAL AIR-BAG DEPLOYMENT AND POSSIBLE PERSONAL INJURY.

If the seat belt reminder lamp fails to light during its display function, replace the seat belt reminder lamp bulb with a known good unit. If the reminder lamp still fails to operate, diagnosis of the lamp and the instrument cluster circuitry should be performed with a DRB scan tool as described in the proper Diagnostic Procedures manual. For further diagnosis of the seat belt indicator lamp and the instrument cluster circuitry, see Instrument Cluster in this group.

TURN SIGNAL INDICATOR LAMP

The diagnosis found here addresses an inoperative turn signal indicator lamp condition. For any other turn signal problem, refer to Group 8J - Turn Signal and Hazard Warning Systems for diagnosis. If no turn signal or hazard warning system problem is found, the following procedure will help locate a short or open in the indicator lamp circuit. For circuit descriptions and diagrams, refer to 8W-40 - Instrument Cluster and 8W-50 - Front Lighting in Group 8W - Wiring Diagrams.

WARNING: ON VEHICLES EQUIPPED WITH AIR-BAGS, REFER TO GROUP 8M - PASSIVE RESTRAINT SYSTEMS BEFORE ATTEMPTING ANY STEERING WHEEL, STEERING COLUMN, OR INSTRUMENT PANEL COMPONENT DIAGNOSIS OR SERVICE. FAILURE TO TAKE THE PROPER PRECAUTIONS COULD RESULT IN ACCIDENTAL AIR-BAG DEPLOYMENT AND POSSIBLE PERSONAL INJURY.

(1) Disconnect and isolate the battery negative cable. Remove the instrument cluster.

(2) Connect the battery negative cable. Activate the hazard warning system by depressing the hazard warning switch button to the On position. Check for battery voltage at the inoperative (right or left) turn signal indicator lamp circuit cavity of the instrument cluster wire harness connector. There should be a switching (on and off) battery voltage signal. If OK, replace the faulty (right or left) indicator lamp bulb.

If not OK, repair the open circuit to the turn signal/hazard warning (multi-function) switch as required.

UPSHIFT INDICATOR LAMP

The diagnosis found here addresses an inoperative upshift indicator lamp condition. If lamp accuracy is suspect, diagnosis should be performed with a DRB scan tool as described in the proper Powertrain Diagnostic Procedures manual. For circuit descriptions and diagrams, refer to 8W-40 - Instrument Cluster in Group 8W - Wiring Diagrams.

WARNING: ON VEHICLES EQUIPPED WITH AIR-BAGS, REFER TO GROUP 8M - PASSIVE RESTRAINT SYSTEMS BEFORE ATTEMPTING STEERING WHEEL, STEERING COLUMN, OR INSTRUMENT PANEL COMPONENT DIAGNOSIS OR SERVICE. FAILURE TO TAKE THE PROPER PRECAUTIONS COULD RESULT IN ACCIDENTAL AIR-BAG DEPLOYMENT AND POSSIBLE PERSONAL INJURY.

If the upshift indicator lamp fails to light during the bulb test (about three seconds after the ignition switch is turned to the On position), replace the upshift indicator lamp bulb with a known good unit. If the indicator lamp still fails to operate, diagnosis of the lamp, the instrument cluster circuitry, or the CCD data bus should be performed with a DRB scan tool as described in the proper Body Diagnostic Procedures manual. Diagnosis of the Powertrain Control Module (PCM) should be performed with a DRB scan tool as described in the proper Powertrain Diagnostic Procedures manual.

VEHICLE INFORMATION CENTER

The Vehicle Information Center (VIC) has a number of display functions and features. The diagnosis found here addresses only those VIC messages and functions that are controlled by hard-wired inputs. To diagnose any internally controlled VIC function or feature, or any that are enabled by inputs on the Chrysler Collision Detection (CCD) data bus network, use a DRB scan tool and the proper Diagnostic Procedures manual. Refer to 8W-46 - Message Center in Group 8W - Wiring Diagrams for complete circuit descriptions and diagrams.

COOLANT LEVEL LOW/COOLANT SENSOR BAD

If the problem being diagnosed is related to message accuracy, be certain to confirm that the problem is with the VIC display and sensor and not with the engine coolant level. The actual engine coolant level should be checked before you proceed with lamp and sensor diagnosis. Refer to 8W-46 - Message Center in

DIAGNOSIS AND TESTING (Continued)

Group 8W - Wiring Diagrams for complete circuit descriptions and diagrams.

WARNING: ON VEHICLES EQUIPPED WITH AIR-BAGS, REFER TO GROUP 8M - PASSIVE RESTRAINT SYSTEMS BEFORE ATTEMPTING ANY STEERING WHEEL, STEERING COLUMN, OR INSTRUMENT PANEL COMPONENT DIAGNOSIS OR SERVICE. FAILURE TO TAKE THE PROPER PRECAUTIONS COULD RESULT IN ACCIDENTAL AIR-BAG DEPLOYMENT AND POSSIBLE PERSONAL INJURY.

(1) Unplug the coolant level sensor wire harness connector from the coolant sensor located on the coolant reserve bottle. Check for continuity between the ground circuit cavity of the coolant level sensor wire harness connector and a good ground. There should be continuity. If OK, go to Step 2. If not OK, repair the open circuit as required.

(2) With the engine coolant at the proper level, check the resistance between the two terminals of the coolant level sensor. The resistance should be 3000 to 3500 ohms. If OK, go to Step 3. If not OK, replace the faulty sensor.

(3) Disconnect and isolate the battery negative cable. Remove the VIC module from the instrument panel. Unplug the VIC module wire harness connector. Check for continuity between the engine coolant level switch sense circuit cavity of the VIC wire harness connector and a good ground. There should be no continuity. If OK, go to Step 4. If not OK, repair the short circuit as required.

(4) Check for continuity between the engine coolant level switch sense circuit cavities of the VIC wire harness connector and the engine coolant level sensor wire harness connector. If OK, replace the faulty VIC module. If not OK, repair the open circuit as required.

FOUR-WHEEL DRIVE DISPLAY AND INDICATORS/SERVICE 4WD SWITCH

If the problem being diagnosed is related to an incorrect or no four-wheel drive display or indicator functions, be certain to confirm that the problem is with the VIC module and transfer case switch circuits, and not with a Powertrain Control Module (PCM) with an incorrect Vehicle Identification Number (VIN). This condition can only occur if the original PCM was replaced with a unit from another vehicle. The VIC module uses the VIN message received on the Chrysler Collision Detection (CCD) data bus from the PCM to determine if the vehicle is equipped with two-wheel drive or four-wheel drive.

If a four-wheel drive vehicle has a two-wheel drive VIN entered in the PCM, the VIC will ignore all transfer case switch inputs. If a two-wheel drive

vehicle has a four-wheel drive VIN entered in the PCM, the rear wheels in the VIC display will not light. Use a DRB scan tool and the proper Diagnostic Procedures manual to confirm the VIN stored in the PCM.

In addition, it should be noted that a VIC "Service 4WD Switch" message on a two-wheel drive vehicle can occur if a short circuit occurs in the transfer case switch circuits from the VIC module, in combination with a PCM having a four-wheel drive VIN. To locate the short circuit, start at Step 3 of the following diagnostic procedure. Two-wheel drive models do have the same VIC wire harness provisions as four-wheel drive models.

WARNING: ON VEHICLES EQUIPPED WITH AIR-BAGS, REFER TO GROUP 8M - PASSIVE RESTRAINT SYSTEMS BEFORE ATTEMPTING ANY STEERING WHEEL, STEERING COLUMN, OR INSTRUMENT PANEL COMPONENT DIAGNOSIS OR SERVICE. FAILURE TO TAKE THE PROPER PRECAUTIONS COULD RESULT IN ACCIDENTAL AIR-BAG DEPLOYMENT AND POSSIBLE PERSONAL INJURY.

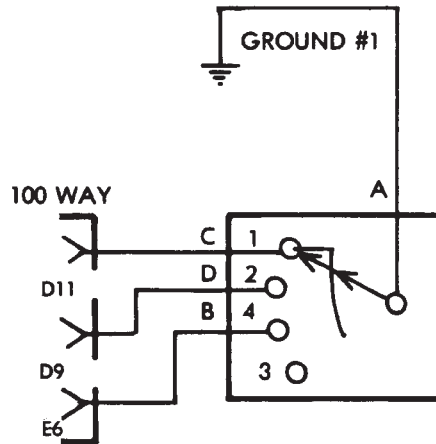
(1) Unplug the wire harness connector at the transfer case switch. Check for continuity between the ground circuit cavity of the transfer case switch wire harness connector and a good ground. There should be continuity. If OK, go to Step 2. If not OK, repair the open circuit as required.

(2) Check the transfer case switch continuity while shifting the transfer case shift lever to the various positions. The switch continuity should be as shown in (Fig. 2). If OK, go to Step 3. If not OK, replace the faulty switch.

(3) Disconnect and isolate the battery negative cable. Remove the VIC module from the instrument panel. Unplug the VIC module wire harness connector.

(4) Locate two pairs of wire harness connectors located in the wire harness leading to the VIC module. The wire harness connectors should be taped back to the harness. One pair of connectors are black with a single cavity. The other pair are red with two cavities. If the vehicle has the Quadra-Trac 4WD transfer case, only the red wire harness connectors should be joined. If the vehicle has the Command-Trac or Selec-Trac 4WD transfer case, only the black wire harness connectors should be joined. In all cases, only one pair of wire harness connectors should be joined. If OK, go to Step 5. If not OK, correct the wire harness connections as required.

DIAGNOSIS AND TESTING (Continued)



231 TRANSFER CASE (COMMAND-TRAC)

T/C POSITION	SWITCH POSITION
2WD	1
4 PART TIME	2
N	3
4 LO	2

242 TRANSFER CASE (SELEC-TRAC)

T/C POSITION	SWITCH POSITION
2WD	1
4 PART TIME	2
4 FULL TIME	4
N	3
4 LO	2

249 TRANSFER CASE (QUADRA-TRAC)

T/C POSITION	SWITCH POSITION
4 ALL TIME	1
N	3
4 LO	2

J948E-63

Fig. 2 Transfer Case Switch

(5) Refer to the VIC 4WD Display Characteristics chart (Fig. 3). Check the continuity of the circuit for the indicator lamp or wheel lamp that is not functioning between the VIC module wire harness connector and the transfer case switch wire harness connector. There should be continuity. If OK, replace the faulty VIC module. If not OK, repair the open circuit as required.

DRIVE SYSTEM (TRANSFER CASE)	VIC 4WD DISPLAY CHARACTERISTICS	TRANSFER CASE SHIFT LEVER POSITION				
		2WD	4 PART TIME	4 FULL/ALL TIME	NEUTRAL	4 LO
4WD QUADRA-TRAC (NP249)	Nomenclature	N/A	N/A	None	None	"LO"
	Lighted Wheels	N/A	N/A	All	None	All
4WD SELEC-TRAC (NP242)	Nomenclature	None	"PART TIME"	"FULL TIME"	None	"PART TIME"
	Lighted Wheels	Rear	All	All	None	All
4WD COMMAND-TRAC (NP231)	Nomenclature	None	"PART TIME"	N/A	None	"PART TIME"
	Lighted Wheels	Rear	All	N/A	None	All
2WD (NONE)	Nomenclature	None	N/A	N/A	N/A	N/A
	Lighted Wheels	None	N/A	N/A	N/A	N/A

N/A=Not Applicable

J958E-42

Fig. 3 VIC 4WD Display Characteristics

DIAGNOSIS AND TESTING (Continued)

REAR LAMP FAILURE

Refer to the diagnosis for the lamp outage module in Group 8L - Lamps to diagnose this feature of the VIC module. Refer to 8W-46 - Message Center in Group 8W - Wiring Diagrams for complete circuit descriptions and diagrams.

TURN SIGNAL ON

Refer to Group 8J - Turn Signal and Hazard Warning Systems for more information on this feature of the VIC module. The VIC module uses its internal programming, and inputs from the combination flasher on the fused ignition switch output (L5) circuit, and a vehicle speed sensor (distance) message received on the Chrysler Collision Detection (CCD) data bus from the Powertrain Control Module (PCM) to control this message.

If testing of the L5 circuit between the VIC module wire harness connector and the combination flasher cavity in the junction block reveals no problem, use a DRB scan tool and the proper Diagnostic Procedures manual to diagnose the VIC module and the CCD data bus. Refer to 8W-46 - Message Center in Group 8W - Wiring Diagrams for complete circuit descriptions and diagrams.

WASHER LEVEL LOW/WASHER SENSOR BAD

If the problem being diagnosed is related to message accuracy, be certain to confirm that the problem is with the VIC display and sensor and not with the washer fluid level. The actual fluid level should be checked before you proceed with lamp and sensor diagnosis. Refer to 8W-46 - Message Center in Group 8W - Wiring Diagrams for complete circuit descriptions and diagrams.

WARNING: ON VEHICLES EQUIPPED WITH AIR-BAGS, REFER TO GROUP 8M - PASSIVE RESTRAINT SYSTEMS BEFORE ATTEMPTING ANY STEERING WHEEL, STEERING COLUMN, OR INSTRUMENT PANEL COMPONENT DIAGNOSIS OR SERVICE. FAILURE TO TAKE THE PROPER PRECAUTIONS COULD RESULT IN ACCIDENTAL AIR-BAG DEPLOYMENT AND POSSIBLE PERSONAL INJURY.

(1) Unplug the washer fluid level sensor wire harness connector from the sensor located on the washer reservoir bottle. Check for continuity between the ground circuit cavity of the washer fluid level sensor wire harness connector and a good ground. There should be continuity. If OK, go to Step 2. If not OK, repair the open circuit as required.

(2) With the washer fluid at the proper level, check the resistance between the two terminals of the washer fluid level sensor. The resistance should

be 3000 to 3500 ohms. If OK, go to Step 3. If not OK, replace the faulty sensor.

(3) Disconnect and isolate the battery negative cable. Remove the VIC module from the instrument panel. Unplug the VIC module wire harness connector. Check for continuity between the washer fluid level sense circuit cavity of the VIC module wire harness connector and a good ground. There should be no continuity. If OK, go to Step 4. If not OK, repair the short circuit as required.

(4) Check for continuity between the washer fluid level sense circuit cavities of the VIC module wire harness connector and the washer fluid level sensor wire harness connector. If OK, replace the faulty VIC module. If not OK, repair the open circuit as required.

WAIT-TO-START LAMP

The diagnosis found here addresses an inoperative wait-to-start lamp condition. If lamp accuracy is suspect, diagnosis should be performed with a DRB scan tool as described in the proper Powertrain Diagnostic Procedures manual. For circuit descriptions and diagrams, refer to 8W-40 - Instrument Cluster in Group 8W - Wiring Diagrams.

WARNING: ON VEHICLES EQUIPPED WITH AIR-BAGS, REFER TO GROUP 8M - PASSIVE RESTRAINT SYSTEMS BEFORE ATTEMPTING STEERING WHEEL, STEERING COLUMN, OR INSTRUMENT PANEL COMPONENT DIAGNOSIS OR SERVICE. FAILURE TO TAKE THE PROPER PRECAUTIONS COULD RESULT IN ACCIDENTAL AIR-BAG DEPLOYMENT AND POSSIBLE PERSONAL INJURY.

If the wait-to-start lamp fails to light during the bulb test (about four seconds after the ignition switch is turned to the On position), replace the wait-to-start lamp bulb with a known good unit. If the lamp still fails to operate, diagnosis of the lamp, the instrument cluster circuitry, or the CCD data bus should be performed with a DRB scan tool as described in the proper Body Diagnostic Procedures manual. Diagnosis of the Powertrain Control Module (PCM) should be performed with a DRB scan tool as described in the proper Powertrain Diagnostic Procedures manual.

WATER-IN-FUEL LAMP

The diagnosis found here addresses an inoperative water-in-fuel lamp condition. If the lamp comes on and stays on with the ignition switch in the On position or while driving, be certain to check for excess water accumulation in the fuel filter/water separator before attempting further diagnosis. Refer to Group 14 - Fuel Systems for diagnosis and service of the

DIAGNOSIS AND TESTING (Continued)

water-in-fuel sensor. For circuit descriptions and diagrams, refer to 8W-40 - Instrument Cluster in Group 8W - Wiring Diagrams.

WARNING: ON VEHICLES EQUIPPED WITH AIRBAGS, REFER TO GROUP 8M - PASSIVE RESTRAINT SYSTEMS BEFORE ATTEMPTING STEERING WHEEL, STEERING COLUMN, OR INSTRUMENT PANEL COMPONENT DIAGNOSIS OR SERVICE. FAILURE TO TAKE THE PROPER PRECAUTIONS COULD RESULT IN ACCIDENTAL AIRBAG DEPLOYMENT AND POSSIBLE PERSONAL INJURY.

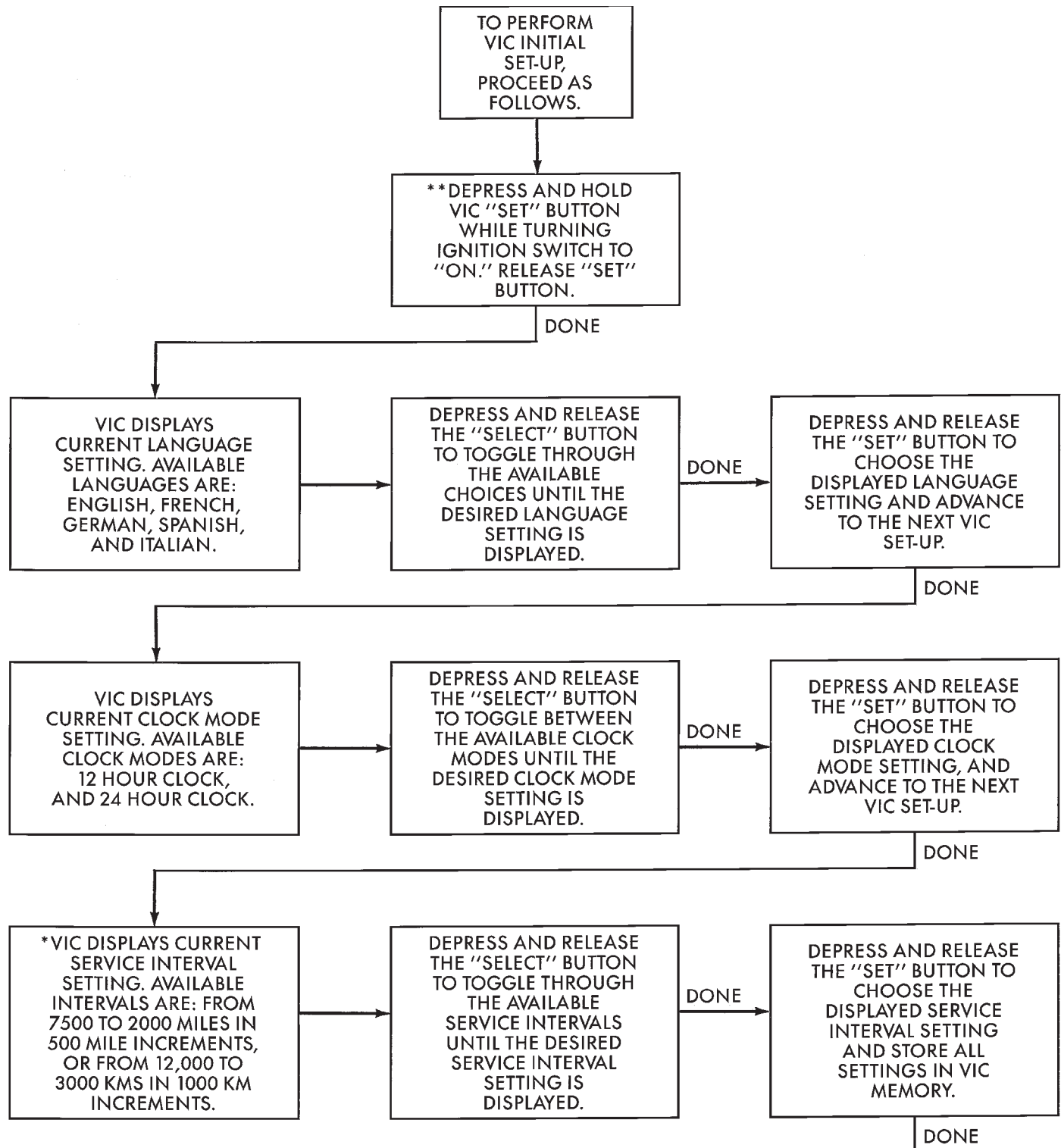
If the water-in-fuel lamp fails to light during the bulb test (about three seconds after the ignition switch is turned to the On position), replace the water-in-fuel lamp bulb with a known good unit. If the indicator lamp still fails to operate, diagnosis of the lamp, the instrument cluster circuitry, or the CCD data bus should be performed with a DRB scan tool as described in the proper Body Diagnostic Procedures manual. Diagnosis of the Powertrain Control Module (PCM) should be performed with a DRB scan tool as described in the proper Powertrain Diagnostic Procedures manual.

SERVICE PROCEDURES**VEHICLE INFORMATION CENTER**

The following flow charts describe the procedures to perform an initial setup of the Vehicle Information Center (VIC), and how to reset the VIC service reminder or time/date settings.

If the vehicle is equipped with a Chrysler radio that is connected to the Chrysler Collision Detection (CCD) data bus network, the hour and minute settings of the VIC clock will automatically be synchronized to the hour and minute settings of the radio clock. This is done by a message that the radio sends to the VIC module on the CCD data bus. Also, the VIC module will automatically suppress the VIC hour and minute set functions if there is a Chrysler radio connected to the CCD data bus, and the VIC clock must be set through the radio clock. Refer to Group 8F - Audio Systems for more information on this feature.

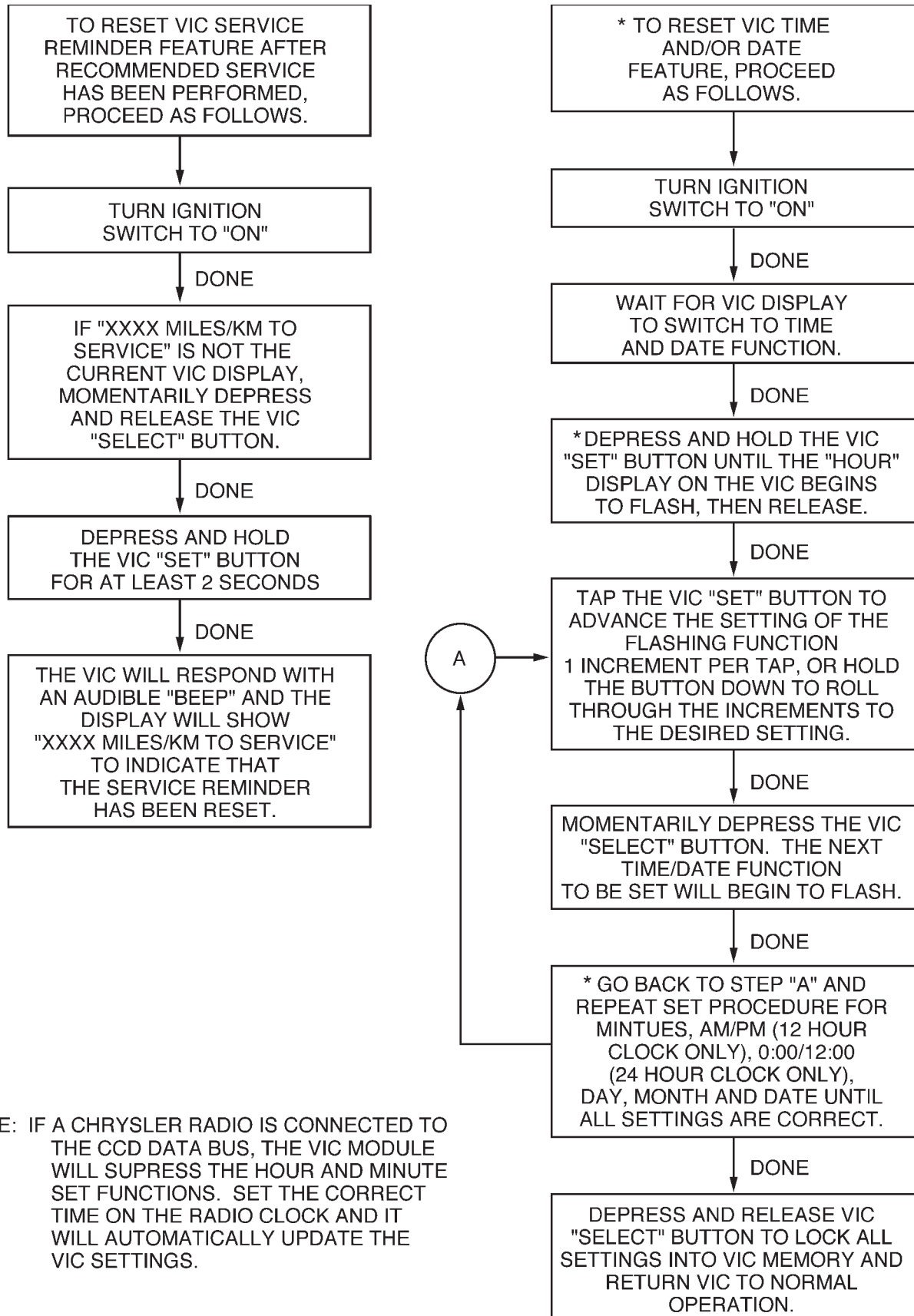
SERVICE PROCEDURES (Continued)



*NOTE: VIC DISPLAY DURING SET-UP WILL REFLECT MILES OR KILOMETERS AS SELECTED WITH THE "US/METRIC" BUTTON IN THE OVERHEAD CONSOLE BEFORE THE SET-UP PROCEDURE WAS BEGUN.

**NOTE: TURNING IGNITION SWITCH TO "OFF" BEFORE ENTIRE SET-UP PROCEDURE IS COMPLETE ABORTS VIC SET-UP AND NOTHING IS SAVED.

SERVICE PROCEDURES (Continued)



*NOTE: IF A CHRYSLER RADIO IS CONNECTED TO THE CCD DATA BUS, THE VIC MODULE WILL SUPPRESS THE HOUR AND MINUTE SET FUNCTIONS. SET THE CORRECT TIME ON THE RADIO CLOCK AND IT WILL AUTOMATICALLY UPDATE THE VIC SETTINGS.

REMOVAL AND INSTALLATION

SWITCH POD BEZEL

WARNING: ON VEHICLES EQUIPPED WITH AIR-BAGS, REFER TO GROUP 8M - PASSIVE RESTRAINT SYSTEMS BEFORE ATTEMPTING ANY STEERING WHEEL, STEERING COLUMN, OR INSTRUMENT PANEL COMPONENT DIAGNOSIS OR SERVICE. FAILURE TO TAKE THE PROPER PRECAUTIONS COULD RESULT IN ACCIDENTAL AIR-BAG DEPLOYMENT AND POSSIBLE PERSONAL INJURY.

(1) Both switch pod bezels are secured to the instrument panel with snap clip retainers and a light snap fit. Using a trim stick or another suitable wide flat-bladed tool, gently pry around the perimeter edges of the bezel to release the snap clip retainers.

(2) Remove the bezel from the instrument panel.

(3) To install the bezel, use one hand to hold it in position on the instrument panel, then use the other hand to push the bezel towards the instrument panel until each of the retainers snaps firmly into place.

STEERING COLUMN OPENING COVER AND KNEE BLOCKER

WARNING: ON VEHICLES EQUIPPED WITH AIR-BAGS, REFER TO GROUP 8M - PASSIVE RESTRAINT SYSTEMS BEFORE ATTEMPTING ANY STEERING WHEEL, STEERING COLUMN, OR INSTRUMENT PANEL COMPONENT DIAGNOSIS OR SERVICE. FAILURE TO TAKE THE PROPER PRECAUTIONS COULD RESULT IN ACCIDENTAL AIR-BAG DEPLOYMENT AND POSSIBLE PERSONAL INJURY.

(1) Disconnect and isolate the battery negative cable.

(2) Remove both switch pod bezels. See Switch Pod Bezel in this group for the procedures.

(3) Remove the one screw on each side of the steering column that secures the upper edge of the steering column opening cover/knee blocker to the instrument panel (Fig. 4).

(4) Remove the one screw that secures the steering column opening cover/knee blocker to the outboard end of instrument panel.

(5) Remove the four screws that secure the lower edge of the steering column opening cover/knee blocker to the lower instrument panel reinforcement.

(6) Using a trim stick or another suitable wide flat-bladed tool, gently pry the edges of the steering column opening cover/knee blocker away from the instrument panel at the snap clip retainer locations (Fig. 4).

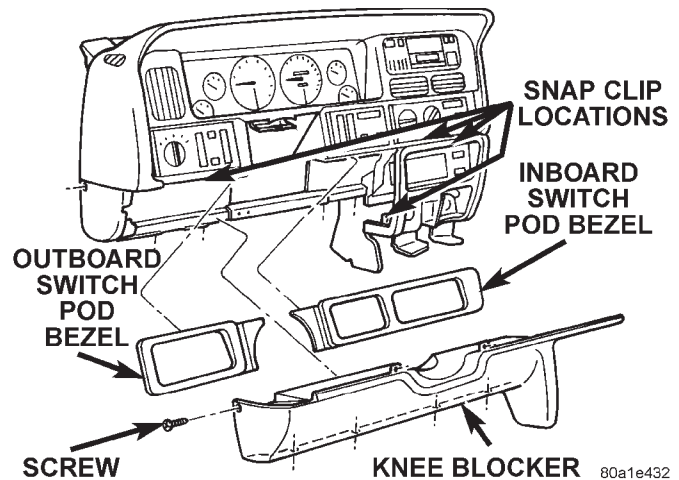


Fig. 4 Steering Column Opening Cover/Knee Blocker Remove/Install

(7) Remove the steering column opening cover/knee blocker from the instrument panel.

(8) Reverse the removal procedures to install. Tighten the mounting screws to 2.2 N·m (20 in. lbs.).

CLUSTER BEZEL

WARNING: ON VEHICLES EQUIPPED WITH AIR-BAGS, REFER TO GROUP 8M - PASSIVE RESTRAINT SYSTEMS BEFORE ATTEMPTING ANY STEERING WHEEL, STEERING COLUMN, OR INSTRUMENT PANEL COMPONENT DIAGNOSIS OR SERVICE. FAILURE TO TAKE THE PROPER PRECAUTIONS COULD RESULT IN ACCIDENTAL AIR-BAG DEPLOYMENT AND POSSIBLE PERSONAL INJURY.

(1) Disconnect and isolate the battery negative cable.

(2) Remove both switch pod bezels from the instrument panel. See Switch Pod Bezel in this group for the procedures.

(3) Remove the ten screws that secure the cluster bezel to the instrument panel (Fig. 5).

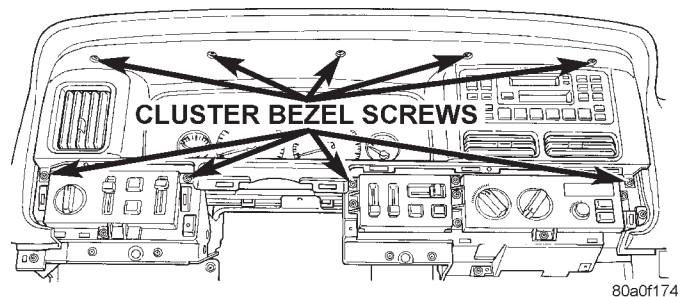


Fig. 5 Cluster Bezel Screws Remove/Install

REMOVAL AND INSTALLATION (Continued)

(4) Pull the cluster bezel rearward and move it to the outboard side of the steering wheel to remove it from the instrument panel.

(5) Reverse the removal procedures to install. Tighten the mounting screws to 2.2 N·m (20 in. lbs.).

INSTRUMENT CLUSTER

WARNING: ON VEHICLES EQUIPPED WITH AIR-BAGS, REFER TO GROUP 8M - PASSIVE RESTRAINT SYSTEMS BEFORE ATTEMPTING ANY STEERING WHEEL, STEERING COLUMN, OR INSTRUMENT PANEL COMPONENT DIAGNOSIS OR SERVICE. FAILURE TO TAKE THE PROPER PRECAUTIONS COULD RESULT IN ACCIDENTAL AIR-BAG DEPLOYMENT AND POSSIBLE PERSONAL INJURY.

(1) Remove the cluster bezel from the instrument panel. See Cluster Bezel in this group for the procedures.

(2) Remove the two screws that secure each end of the instrument cluster to the instrument panel.

(3) Pull the instrument cluster rearward to disengage the self-docking wire harness connector.

NOTE: The instrument cluster has a self-docking wire harness connector that will be automatically aligned with, and connected to the instrument panel

wire harness when the cluster is installed in the instrument panel.

(4) Remove the instrument cluster from the instrument panel.

(5) Reverse the removal procedures to install. Tighten the mounting screws to 2.2 N·m (20 in. lbs.).

CLUSTER LENS, HOOD, AND MASK

WARNING: ON VEHICLES EQUIPPED WITH AIR-BAGS, REFER TO GROUP 8M - PASSIVE RESTRAINT SYSTEMS BEFORE ATTEMPTING STEERING WHEEL, STEERING COLUMN, OR INSTRUMENT PANEL COMPONENT DIAGNOSIS OR SERVICE. FAILURE TO TAKE THE PROPER PRECAUTIONS COULD RESULT IN ACCIDENTAL AIR-BAG DEPLOYMENT AND POSSIBLE PERSONAL INJURY.

(1) Remove the cluster bezel as described in this group.

(2) Remove the instrument cluster as described in this group.

(3) Remove the trip odometer reset knob by pulling it off of the switch stem (Fig. 6).

(4) Depress the snap clips that secure the cluster lens to the cluster hood and gently pull the lens away from the hood.

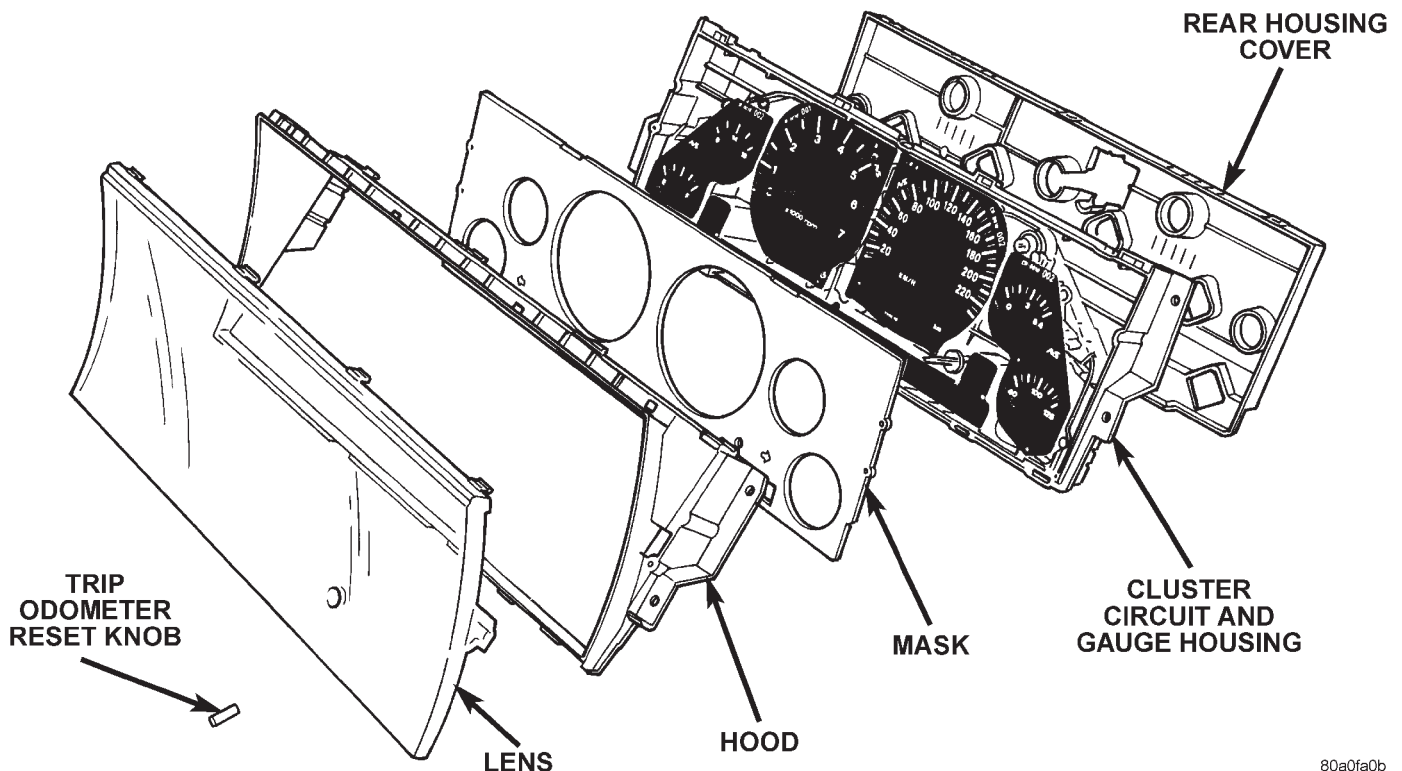
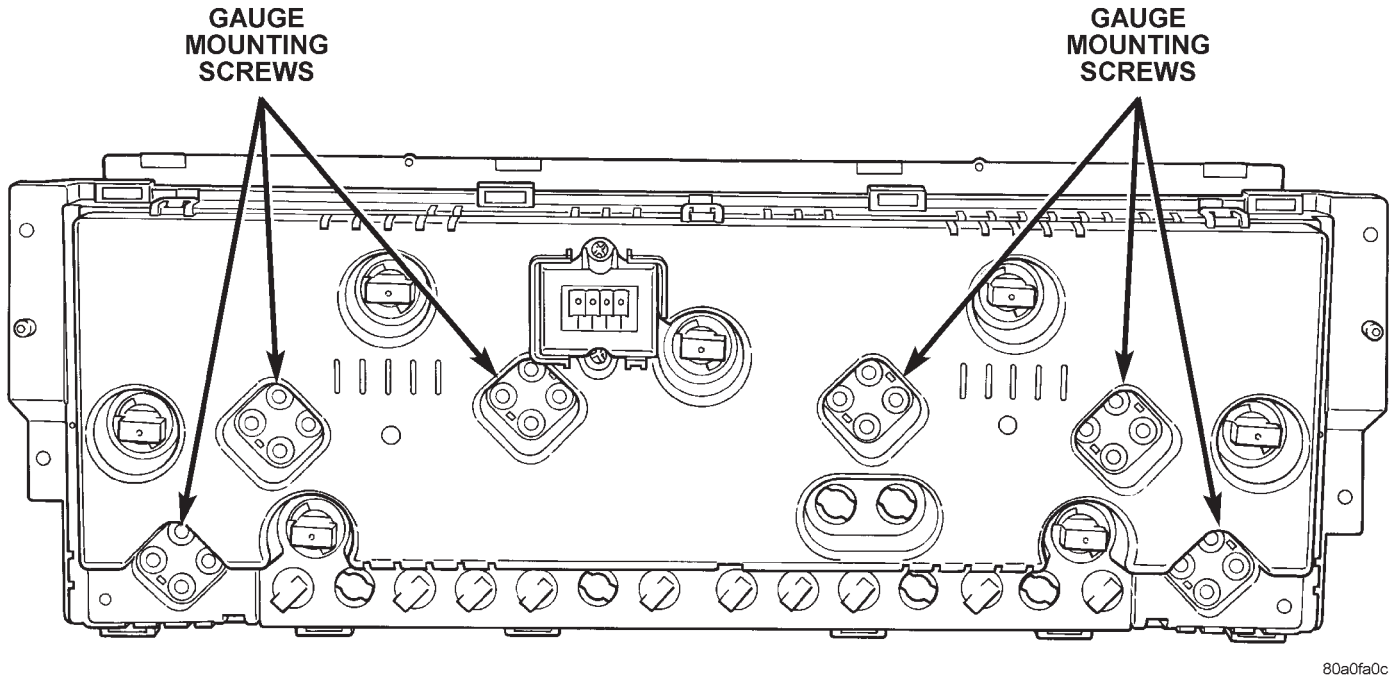


Fig. 6 Instrument Cluster Components

REMOVAL AND INSTALLATION (Continued)



80a0fa0c

Fig. 7 Gauge Mounting Screws

(5) Depress the snap clips that secure the cluster hood to the cluster circuit and gauge housing and gently pull the hood away from the housing.

(6) Gently lift the gauge mask away from the locating pins on the front of the cluster circuit and gauge housing.

(7) Reverse the removal procedures to install.

GAUGE

WARNING: ON VEHICLES EQUIPPED WITH AIR-BAGS, REFER TO GROUP 8M - PASSIVE RESTRAINT SYSTEMS BEFORE ATTEMPTING STEERING WHEEL, STEERING COLUMN, OR INSTRUMENT PANEL COMPONENT DIAGNOSIS OR

SERVICE. FAILURE TO TAKE THE PROPER PRECAUTIONS COULD RESULT IN ACCIDENTAL AIR-BAG DEPLOYMENT AND POSSIBLE PERSONAL INJURY.

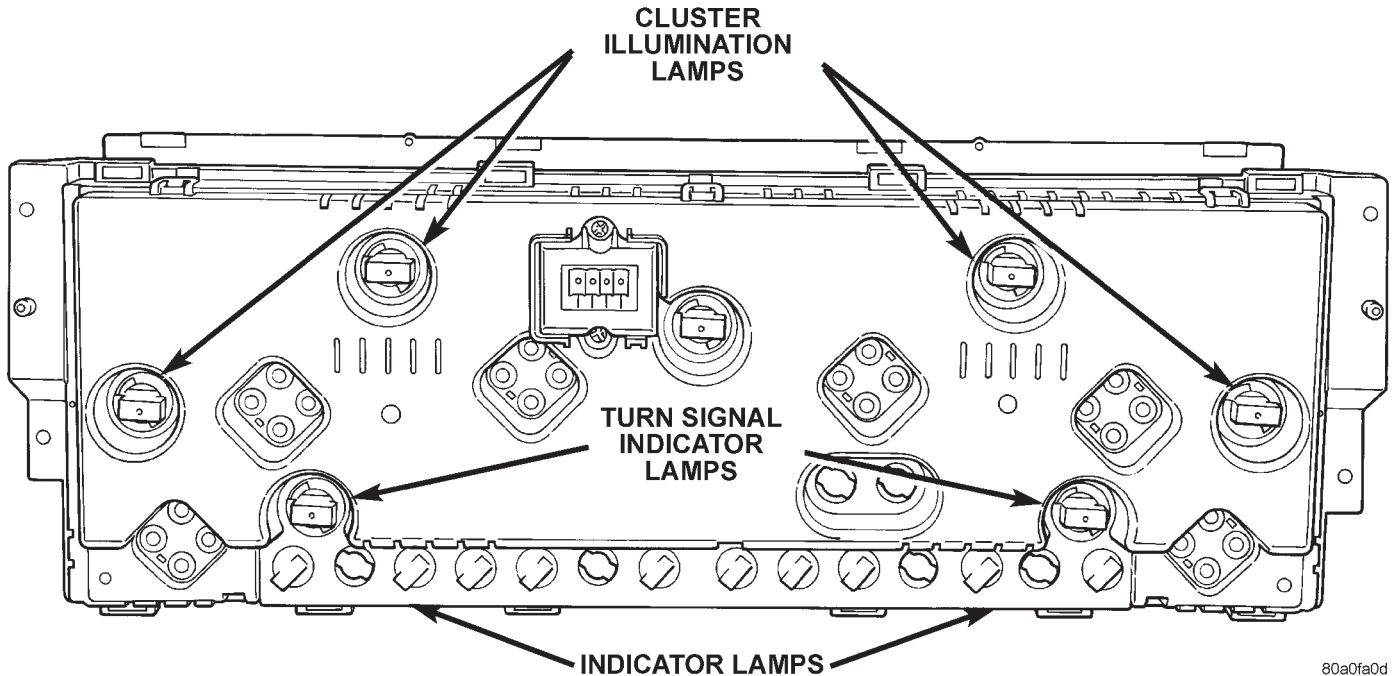
(1) Remove the cluster lens, hood, and mask as described in this group.

(2) Remove the screws that secure the gauge(s) from the rear of the cluster circuit and gauge housing (Fig. 7).

(3) Remove the gauge(s) from the front of the cluster circuit and gauge housing.

(4) Reverse the removal procedures to install.

REMOVAL AND INSTALLATION (Continued)



80a0fa0d

Fig. 8 Cluster Bulb Locations

CLUSTER BULB

WARNING: ON VEHICLES EQUIPPED WITH AIRBAGS, REFER TO GROUP 8M - PASSIVE RESTRAINT SYSTEMS BEFORE ATTEMPTING ANY STEERING WHEEL, STEERING COLUMN, OR INSTRUMENT PANEL COMPONENT DIAGNOSIS OR SERVICE. FAILURE TO TAKE THE PROPER PRECAUTIONS COULD RESULT IN ACCIDENTAL AIRBAG DEPLOYMENT AND POSSIBLE PERSONAL INJURY.

- (1) Remove the instrument cluster from the instrument panel. See Instrument Cluster in this group for the procedures.
- (2) Remove the bulb and bulb holder from the circuit board on the rear of the cluster housing by turning the holder counterclockwise (Fig. 8).

CAUTION: Always use the correct bulb size and type for replacement. An incorrect bulb size or type may overheat and cause damage to the instrument cluster circuit board and/or the gauges.

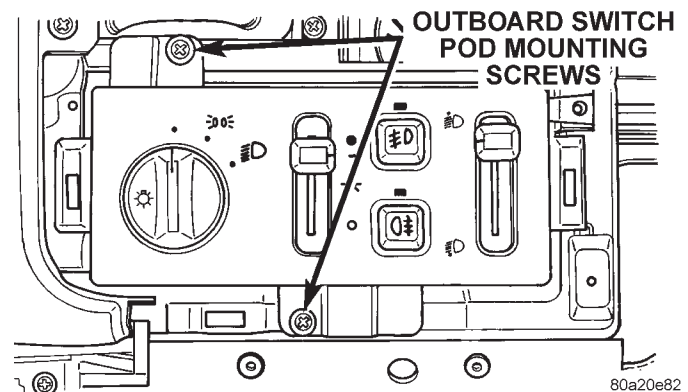
- (3) Reverse the removal procedures to install.

OUTBOARD SWITCH POD

WARNING: ON VEHICLES EQUIPPED WITH AIRBAGS, REFER TO GROUP 8M - PASSIVE RESTRAINT SYSTEMS BEFORE ATTEMPTING ANY STEERING WHEEL, STEERING COLUMN, OR INSTRUMENT PANEL COMPONENT DIAGNOSIS OR

SERVICE. FAILURE TO TAKE THE PROPER PRECAUTIONS COULD RESULT IN ACCIDENTAL AIRBAG DEPLOYMENT AND POSSIBLE PERSONAL INJURY.

- (1) Remove the cluster bezel from the instrument panel. See Cluster Bezel in this group for the procedures.
- (2) Remove the two screws that secure the outboard switch pod to the instrument panel (Fig. 9).



80a20e82

Fig. 9 Outboard Switch Pod Remove/Install

- (3) Pull the outboard switch pod out from the instrument panel far enough to unplug the wire harness connectors.
- (4) Remove the outboard switch pod from the instrument panel.
- (5) Reverse the removal procedures to install. Tighten the mounting screws to 2.2 N·m (20 in. lbs.).

REMOVAL AND INSTALLATION (Continued)

INBOARD SWITCH POD

WARNING: ON VEHICLES EQUIPPED WITH AIR-BAGS, REFER TO GROUP 8M - PASSIVE RESTRAINT SYSTEMS BEFORE ATTEMPTING ANY STEERING WHEEL, STEERING COLUMN, OR INSTRUMENT PANEL COMPONENT DIAGNOSIS OR SERVICE. FAILURE TO TAKE THE PROPER PRECAUTIONS COULD RESULT IN ACCIDENTAL AIR-BAG DEPLOYMENT AND POSSIBLE PERSONAL INJURY.

- (1) Remove the cluster bezel from the instrument panel. See Cluster Bezel in this group for the procedures.
- (2) Remove the two screws that secure the inboard switch pod to the instrument panel (Fig. 10).

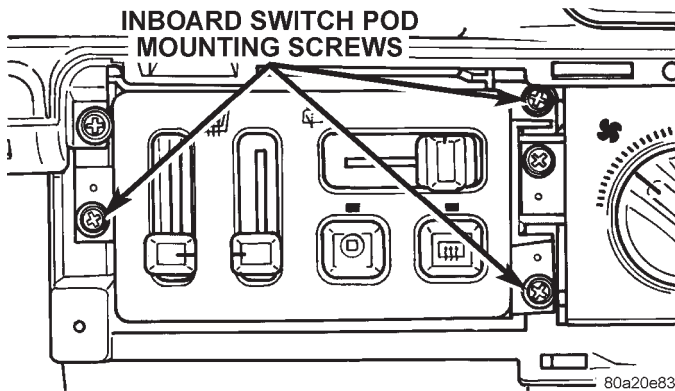


Fig. 10 Inboard Switch Pod Remove/Install

- (3) Pull the inboard switch pod out from the instrument panel far enough to unplug the wire harness connectors.
- (4) Remove the inboard switch pod from the instrument panel.
- (5) Reverse the removal procedures to install. Tighten the mounting screws to 2.2 N·m (20 in. lbs.).

BODY CONTROL MODULE

Before replacing the Body Control Module (BCM), use a DRB scan tool to determine the current settings for the BCM programmable features. These settings should be duplicated in the replacement BCM using the DRB scan tool, before returning the vehicle to service.

WARNING: ON VEHICLES EQUIPPED WITH AIR-BAGS, REFER TO GROUP 8M - PASSIVE RESTRAINT SYSTEMS BEFORE ATTEMPTING ANY STEERING WHEEL, STEERING COLUMN, OR INSTRUMENT PANEL COMPONENT DIAGNOSIS OR SERVICE. FAILURE TO TAKE THE PROPER PRECAUTIONS COULD RESULT IN ACCIDENTAL AIR-BAG DEPLOYMENT AND POSSIBLE PERSONAL INJURY.

- (1) Remove the steering column opening cover/knee blocker from the instrument panel. See Steering Column Opening Cover and Knee Blocker in this group for the procedures.
- (2) Remove the four screws located below the outboard switch pod that secure the Body Control Module (BCM) to the instrument panel armature (Fig. 11).

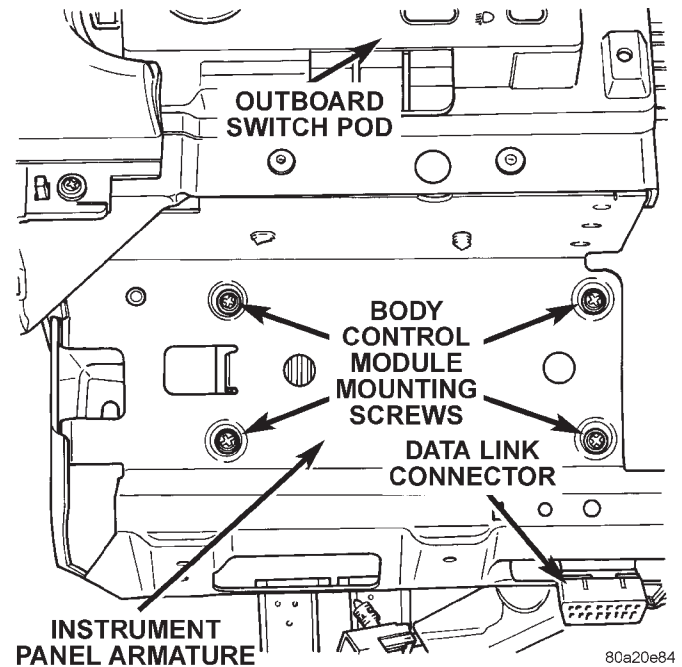


Fig. 11 Body Control Module Remove/Install

- (3) Move the BCM towards the steering column far enough to access the three wire harness connectors.
- (4) Unplug the wire harness connectors from the BCM.
- (5) Remove the BCM from the instrument panel.
- (6) Reverse the removal procedures to install. Tighten the mounting screws to 2.2 N·m (20 in. lbs.).

NOTE: If a new Body Control Module is installed, the programmable features must be enabled and/or disabled to the customer's preferred settings. Use a DRB scan tool and the proper Diagnostic Procedures manual to perform these operations.

REMOVAL AND INSTALLATION (Continued)**GLOVE BOX MODULE**

WARNING: ON VEHICLES EQUIPPED WITH AIR-BAGS, REFER TO GROUP 8M - PASSIVE RESTRAINT SYSTEMS BEFORE ATTEMPTING ANY STEERING WHEEL, STEERING COLUMN, OR INSTRUMENT PANEL COMPONENT DIAGNOSIS OR SERVICE. FAILURE TO TAKE THE PROPER PRECAUTIONS COULD RESULT IN ACCIDENTAL AIR-BAG DEPLOYMENT AND POSSIBLE PERSONAL INJURY.

(1) Remove the steering column opening cover/knee blocker from the instrument panel. See Steering Column Opening Cover and Knee Blocker in this group for the procedures.

(2) Remove the two screws that secure the top of the instrument panel center bezel to the instrument panel above the Graphic Display Module (GDM) or Vehicle Information Center (VIC).

(3) Remove the ash receiver from the instrument panel center bezel.

(4) Remove the two screws in the back of the ash receiver opening that secure the instrument panel center bezel to the instrument panel armature.

(5) Remove the screw that secures the courtesy lamp to the lower instrument panel located under the outboard end of the glove box module.

(6) Open the passenger side front door and remove the screw that secures the outboard end of the glove box module to the instrument panel armature.

(7) Remove the four screws that secure the glove box hinge to the instrument panel armature on the lower edge of the glove box module.

(8) Open the glove box door and remove the four screws at the top of the glove box opening that secure the upper edge of the glove box module to the instrument panel armature.

(9) Lower the glove box module far enough to access and unplug the wire harness connectors from the glove box lamp and switch, the cigar lighter and lamp, and the power outlet. Also remove the ash receiver lamp bulb and socket as a unit by gently pulling it out of the ash receiver lamp hood.

(10) Remove the glove box module from the instrument panel.

(11) Reverse the removal procedures to install. Tighten the mounting screws to 2.2 N·m (20 in. lbs.).

GRAPHIC DISPLAY MODULE AND VEHICLE INFORMATION CENTER

WARNING: ON VEHICLES EQUIPPED WITH AIR-BAGS, REFER TO GROUP 8M - PASSIVE RESTRAINT SYSTEMS BEFORE ATTEMPTING ANY STEERING WHEEL, STEERING COLUMN, OR INSTRUMENT PANEL COMPONENT DIAGNOSIS OR

SERVICE. FAILURE TO TAKE THE PROPER PRECAUTIONS COULD RESULT IN ACCIDENTAL AIR-BAG DEPLOYMENT AND POSSIBLE PERSONAL INJURY.

(1) Remove the glove box module from the instrument panel. See Glove Box Module in this group for the procedures.

(2) Remove the three screws that secure the Graphic Display Module (GDM) or Vehicle Information Center (VIC) to the instrument panel armature (Fig. 12).

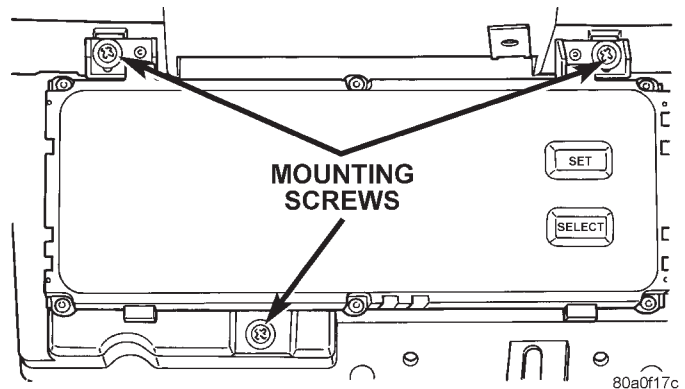


Fig. 12 Graphic Display Module and Vehicle Information Center Remove/Install

(3) Pull the GDM or VIC unit out from the instrument panel far enough to access and unplug the wire harness connector.

(4) Remove the GDM or VIC from the instrument panel.

(5) Reverse the removal procedures to install. Tighten the mounting screws to 2.2 N·m (20 in. lbs.).

GLOVE BOX LAMP AND SWITCH

WARNING: ON VEHICLES EQUIPPED WITH AIR-BAGS, REFER TO GROUP 8M - PASSIVE RESTRAINT SYSTEMS BEFORE ATTEMPTING ANY STEERING WHEEL, STEERING COLUMN, OR INSTRUMENT PANEL COMPONENT DIAGNOSIS OR SERVICE. FAILURE TO TAKE THE PROPER PRECAUTIONS COULD RESULT IN ACCIDENTAL AIR-BAG DEPLOYMENT AND POSSIBLE PERSONAL INJURY.

(1) Remove the glove box module from the instrument panel. See Glove Box Module in this group for the procedures.

(2) From the back side of the glove box module, squeeze the retaining tabs on the glove box lamp and switch housing together and push the unit out through the mounting hole towards the front of the module (Fig. 13).

REMOVAL AND INSTALLATION (Continued)

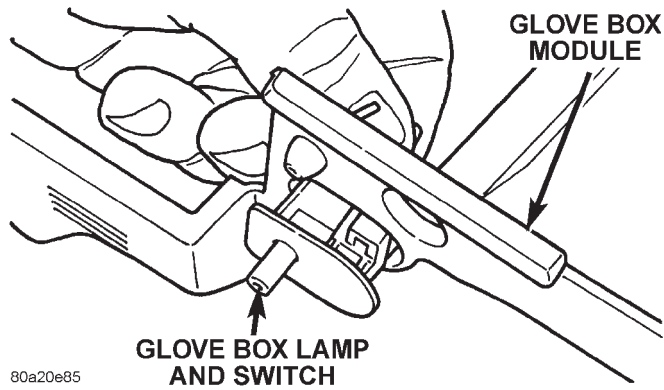


Fig. 13 Glove Box Lamp and Switch Remove/Install

(3) To install the glove box lamp and switch unit, insert the unit through the mounting hole from the front of the glove box module and push in on the unit firmly, until the retaining tabs snap into place.

(4) Reverse the remaining removal procedures to complete the installation.

GLOVE BOX LATCH STRIKER

WARNING: ON VEHICLES EQUIPPED WITH AIR-BAGS, REFER TO GROUP 8M - PASSIVE RESTRAINT SYSTEMS BEFORE ATTEMPTING ANY STEERING WHEEL, STEERING COLUMN, OR INSTRUMENT PANEL COMPONENT DIAGNOSIS OR SERVICE. FAILURE TO TAKE THE PROPER PRECAUTIONS COULD RESULT IN ACCIDENTAL AIR-BAG DEPLOYMENT AND POSSIBLE PERSONAL INJURY.

(1) Remove the glove box module from the instrument panel. See Glove Box Module in this group for the procedures.

(2) From the top of the glove box module, straighten the two mounting tabs that secure the glove box latch striker to the glove box module (Fig. 14).

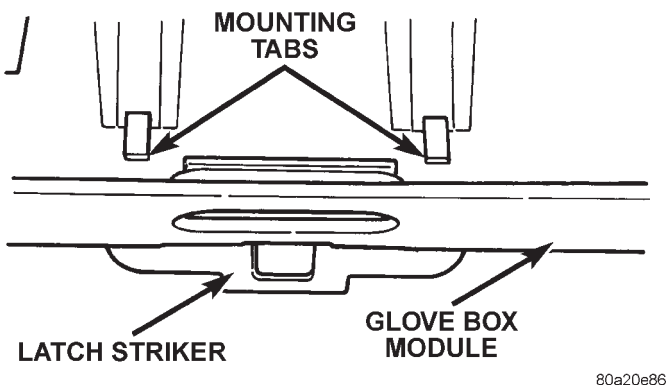


Fig. 14 Glove Box Latch Striker Remove/Install

(3) Remove the latch striker through the upper glove box opening of the glove box module.

(4) To install the latch striker, insert the mounting tabs through the slots in the upper glove box opening of the glove box module, and bend the tabs over from the top of the glove box module.

CIGAR LIGHTER

WARNING: ON VEHICLES EQUIPPED WITH AIR-BAGS, REFER TO GROUP 8M - PASSIVE RESTRAINT SYSTEMS BEFORE ATTEMPTING ANY STEERING WHEEL, STEERING COLUMN, OR INSTRUMENT PANEL COMPONENT DIAGNOSIS OR SERVICE. FAILURE TO TAKE THE PROPER PRECAUTIONS COULD RESULT IN ACCIDENTAL AIR-BAG DEPLOYMENT AND POSSIBLE PERSONAL INJURY.

(1) Disconnect and isolate the battery negative cable.

(2) Pull the cigar lighter knob and element out of the cigar lighter base.

(3) Look inside the cigar lighter base and note the position of the retaining bosses that secure the unit to the light ring/retainer in the instrument panel center bezel (Fig. 15).

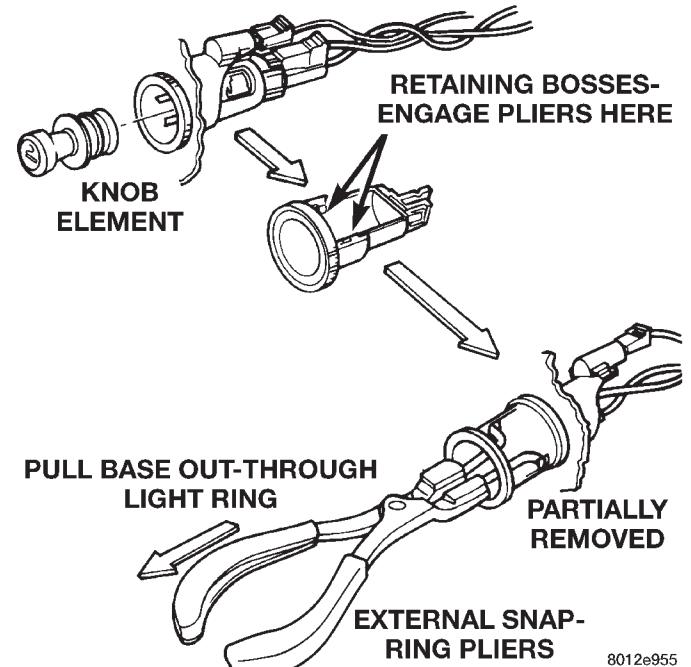


Fig. 15 Cigar Lighter Remove/Install

(4) Insert a pair of external snap ring pliers into the cigar lighter base and engage the tips of the pliers with the retaining bosses.

(5) Squeeze the pliers to disengage the retaining bosses from the base, and using a gentle rocking

REMOVAL AND INSTALLATION (Continued)

motion pull the pliers and the cigar lighter base out of the light ring/retainer.

(6) Remove the pliers from the cigar lighter base and unplug the cigar lighter wire harness connector.

(7) Remove the cigar lighter light ring/retainer from the instrument panel center bezel and unplug the light ring lamp wire harness connector.

(8) Reverse the removal procedures to install.

POWER OUTLET

WARNING: ON VEHICLES EQUIPPED WITH AIR-BAGS, REFER TO GROUP 8M - PASSIVE RESTRAINT SYSTEMS BEFORE ATTEMPTING ANY STEERING WHEEL, STEERING COLUMN, OR INSTRUMENT PANEL COMPONENT DIAGNOSIS OR SERVICE. FAILURE TO TAKE THE PROPER PRECAUTIONS COULD RESULT IN ACCIDENTAL AIR-BAG DEPLOYMENT AND POSSIBLE PERSONAL INJURY.

(1) Remove the glove box module from the instrument panel. See Glove Box Module in this group for the procedures.

(2) From the rear of the instrument panel center bezel, unscrew the power outlet receptacle shell clamp from the power outlet receptacle shell base.

(3) Remove the power outlet receptacle shell base from the front of the instrument panel center bezel.

(4) Reverse the removal procedures to install.

POWER OUTLET DOOR

(1) Insert a trim stick or another suitable wide flat-bladed tool between the side of the power outlet housing in the instrument panel center bezel and the upper pivot area of the power outlet door.

(2) Pry gently against the upper pivot area of the power outlet door until the door pivot pin clears the pivot receptacle in the instrument panel center bezel.

(3) Pull the power outlet door out of the power outlet housing using a twisting motion.

(4) To install the door, insert one of the pivot pins into a pivot receptacle in the instrument panel center bezel and twist the door gently until the pivot pin on the opposite side of the door snaps into the other center bezel pivot receptacle.

INSTRUMENT PANEL CENTER BEZEL

WARNING: ON VEHICLES EQUIPPED WITH AIR-BAGS, REFER TO GROUP 8M - PASSIVE RESTRAINT SYSTEMS BEFORE ATTEMPTING ANY STEERING WHEEL, STEERING COLUMN, OR INSTRUMENT PANEL COMPONENT DIAGNOSIS OR SERVICE. FAILURE TO TAKE THE PROPER PRECAUTIONS COULD RESULT IN ACCIDENTAL AIR-

BAG DEPLOYMENT AND POSSIBLE PERSONAL INJURY.

(1) Remove the glove box module from the instrument panel. See Glove Box Module in this group for the procedures.

(2) Remove the two screws located on the back side of the glove box module that secure the instrument panel center bezel to the inboard end of the glove box module (Fig. 16).

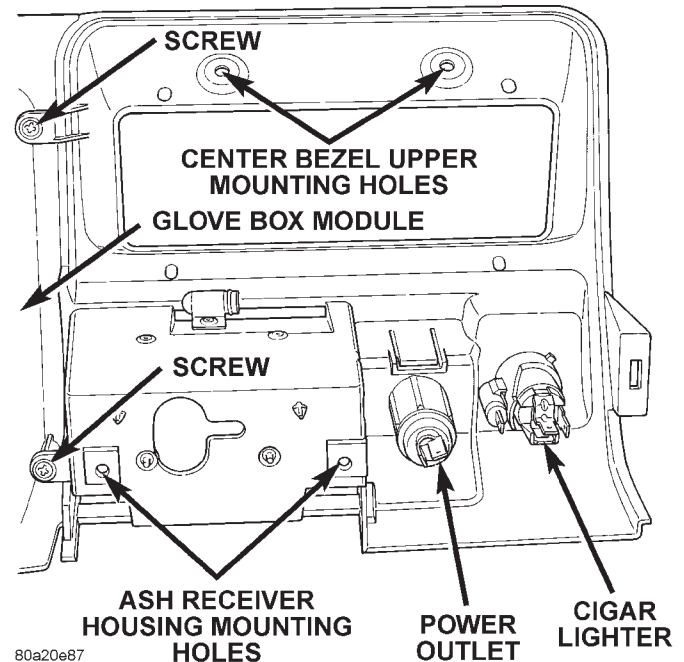


Fig. 16 Instrument Panel Center Bezel Remove/Install

(3) Reverse the removal procedures to install. Tighten the mounting screws to 2.2 N·m (20 in. lbs.).

GLOVE BOX

WARNING: ON VEHICLES EQUIPPED WITH AIR-BAGS, REFER TO GROUP 8M - PASSIVE RESTRAINT SYSTEMS BEFORE ATTEMPTING ANY STEERING WHEEL, STEERING COLUMN, OR INSTRUMENT PANEL COMPONENT DIAGNOSIS OR SERVICE. FAILURE TO TAKE THE PROPER PRECAUTIONS COULD RESULT IN ACCIDENTAL AIR-BAG DEPLOYMENT AND POSSIBLE PERSONAL INJURY.

(1) Disconnect and isolate the battery negative cable.

(2) Drill out the two rivets that secure the glove box hinge to the lower edge of the glove box module (Fig. 17).

REMOVAL AND INSTALLATION (Continued)

NOTE: The rivets are used to ease assembly during the manufacturing process, but do not require replacement following service.

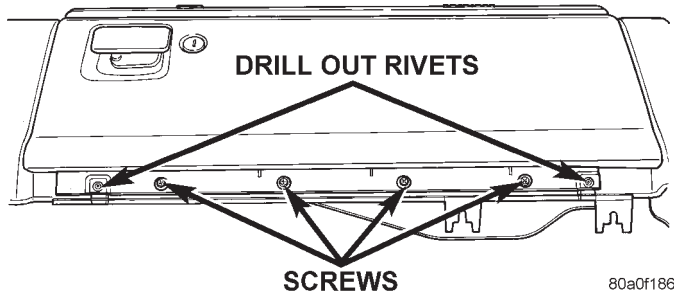


Fig. 17 Glove Box Remove/Install

- (3) Remove the four screws that secure the glove box hinge to the instrument panel armature.
- (4) Release the glove box latch and remove the glove box from the glove box module.
- (5) Reverse the removal procedures to install. Tighten the mounting screws to 2.2 N·m (20 in. lbs.).

GLOVE BOX COMPONENTS

The glove box bezel is the only component of the glove box that can be serviced without glove box removal. All other components will require that the glove box be removed from the instrument panel.

GLOVE BOX BEZEL

- (1) Open the glove box.
- (2) Remove the two screws that secure the bezel to the glove box near the top of the glove box inner door panel (Fig. 18).

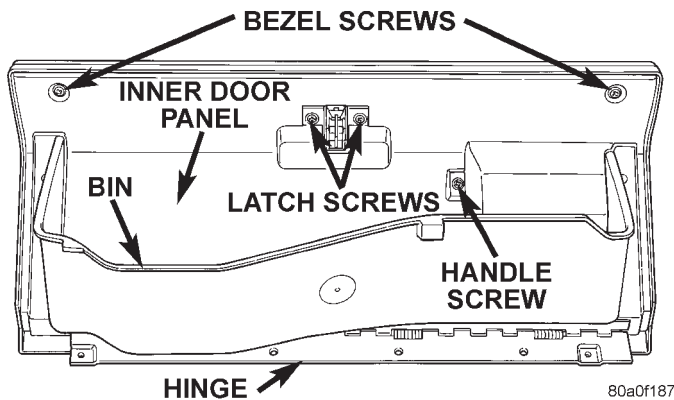


Fig. 18 Glove Box Components

- (3) Using a trim stick or another suitable wide flat-bladed tool, gently pry the bezel away from the outside of the glove box door. There is double-faced adhesive tape between the bezel and the outer door panel.
- (4) Reverse the removal procedures to install. Tighten the mounting screws to 2.2 N·m (20 in. lbs.).

GLOVE BOX HINGE

- (1) Remove the glove box from the instrument panel. See Glove Box in this group for the procedures.
- (2) Remove the screws that secure the glove box hinge to the glove box inner door panel.
- (3) Remove the glove box hinge from the glove box door.
- (4) Reverse the removal procedures to install. Tighten the mounting screws to 2.2 N·m (20 in. lbs.).

GLOVE BOX BIN

- (1) Remove the glove box hinge from the glove box door. See Glove Box Hinge in this group for the procedures.
- (2) Remove the screws that secure each side of the glove box bin to the glove box door.
- (3) Remove the glove box bin from the glove box door.
- (4) Reverse the removal procedures to install. Tighten the mounting screws to 2.2 N·m (20 in. lbs.).

GLOVE BOX LATCH AND HANDLE

- (1) Remove the glove box bin from the glove box door. See Glove Box Bin in this group for the procedures.
- (2) Remove the two bezel screws, two latch screws, and one handle screw from the glove box inner door panel.
- (3) Remove the glove box inner door panel from the glove box outer door panel.
- (4) Remove the screw that secures the glove box latch and handle to the inside of the glove box outer door panel (Fig. 19).

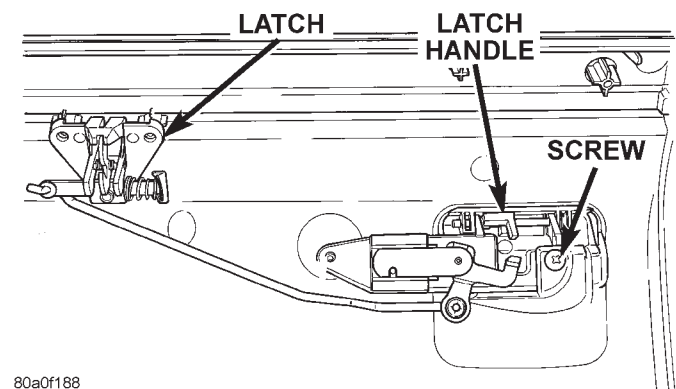


Fig. 19 Glove Box Latch and Handle Remove/Install

- (5) Remove the latch and handle from the glove box door as a unit.
- (6) Reverse the removal procedures to install. Tighten the mounting screws to 2.2 N·m (20 in. lbs.).

REMOVAL AND INSTALLATION (Continued)**GLOVE BOX LOCK CYLINDER**

(1) Remove the glove box latch and handle from the glove box. See Glove Box Latch and Handle in this group for the procedures.

(2) Insert the glove box key into the glove box lock cylinder.

(3) Insert a small screwdriver into the retaining tumbler release slot and depress the retaining tumbler (Fig. 20).

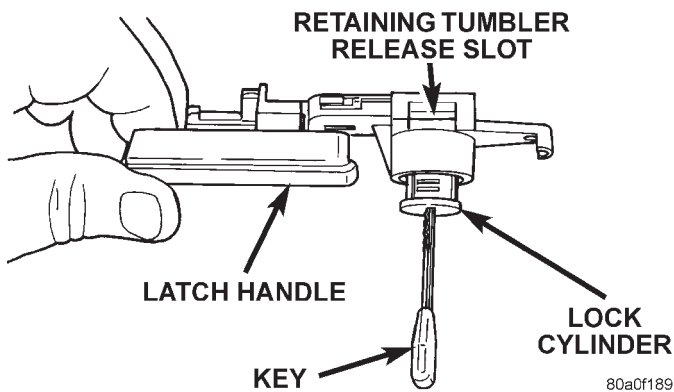


Fig. 20 Glove Box Lock Cylinder Remove/Install

(4) Pull the lock cylinder out of the latch handle by using a gentle twisting and pulling action on the key.

(5) Reverse the removal procedures to install.

COWL TOP TRIM PANEL

WARNING: ON VEHICLES EQUIPPED WITH AIRBAGS, REFER TO GROUP 8M - PASSIVE RESTRAINT SYSTEMS BEFORE ATTEMPTING ANY STEERING WHEEL, STEERING COLUMN, OR INSTRUMENT PANEL COMPONENT DIAGNOSIS OR SERVICE. FAILURE TO TAKE THE PROPER PRECAUTIONS COULD RESULT IN ACCIDENTAL AIRBAG DEPLOYMENT AND POSSIBLE PERSONAL INJURY.

(1) Disconnect and isolate the battery negative cable.

(2) Using a trim stick or another suitable wide flat-bladed tool, gently pry the cowl top trim panel off of the instrument panel top pad (Fig. 21).

(3) Pull the trim panel up far enough to access and unplug the wire harness connector for the solar sensor, or to remove the solar sensor from the cowl top trim, if the vehicle is so equipped.

(4) Remove the cowl top trim panel from the instrument panel.

(5) Reverse the removal procedures to install.

INSTRUMENT PANEL TOP PAD

WARNING: ON VEHICLES EQUIPPED WITH AIRBAGS, REFER TO GROUP 8M - PASSIVE

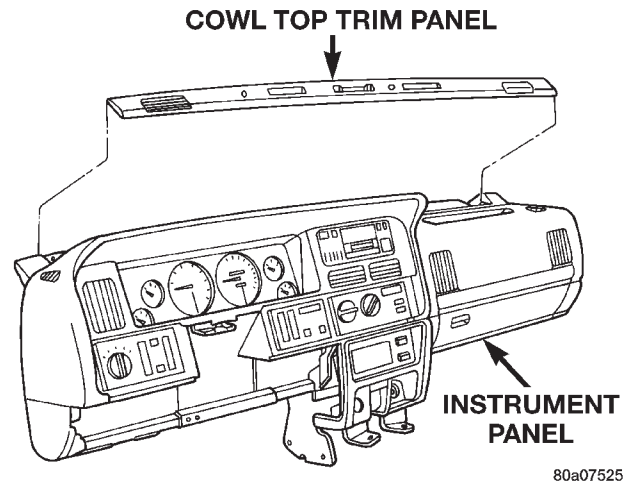


Fig. 21 Cowl Top Trim Remove/Install

RESTRAINT SYSTEMS BEFORE ATTEMPTING ANY STEERING WHEEL, STEERING COLUMN, OR INSTRUMENT PANEL COMPONENT DIAGNOSIS OR SERVICE. FAILURE TO TAKE THE PROPER PRECAUTIONS COULD RESULT IN ACCIDENTAL AIRBAG DEPLOYMENT AND POSSIBLE PERSONAL INJURY.

NOTE: Be sure when replacing the instrument panel top pad that all airbag warning labels are in place.

(1) Disconnect and isolate the battery negative cable.

(2) Remove the steering column opening cover and knee blocker from the instrument panel. See Steering Column Opening Cover and Knee Blocker in this group for the procedures.

(3) Remove the cluster bezel from the instrument panel. See Cluster Bezel in this group for the procedures.

(4) Remove the glove box module from the instrument panel. See Glove Box Module in this group for the procedures.

(5) Remove the cowl top trim panel from the instrument panel. See Cowl Top Trim Panel in this group for the procedures.

(6) If the vehicle is so equipped, remove the screw that secures the auto headlamp light sensor/vehicle theft security system lamp to the top of the instrument panel near the defroster duct outlet, and move it far enough for clearance during removal of the instrument panel top pad.

(7) Remove all of the screws that secure the perimeter of the instrument panel top pad to the instrument panel armature.

(8) Remove the instrument panel top pad from the instrument panel armature.

REMOVAL AND INSTALLATION (Continued)

(9) Reverse the removal procedures to install. Tighten the mounting screws to 2.2 N·m (20 in. lbs.).

JUNCTION BLOCK

WARNING: ON VEHICLES EQUIPPED WITH AIR-BAGS, REFER TO GROUP 8M - PASSIVE RESTRAINT SYSTEMS BEFORE ATTEMPTING ANY STEERING WHEEL, STEERING COLUMN, OR INSTRUMENT PANEL COMPONENT DIAGNOSIS OR SERVICE. FAILURE TO TAKE THE PROPER PRECAUTIONS COULD RESULT IN ACCIDENTAL AIR-BAG DEPLOYMENT AND POSSIBLE PERSONAL INJURY.

- (1) Disconnect and isolate the battery negative cable.
- (2) Remove the fuse access panel by unsnapping it from the right cowl side trim panel.
- (3) Remove the push nut that secures the right cowl side trim panel to the junction block stud (Fig. 22).

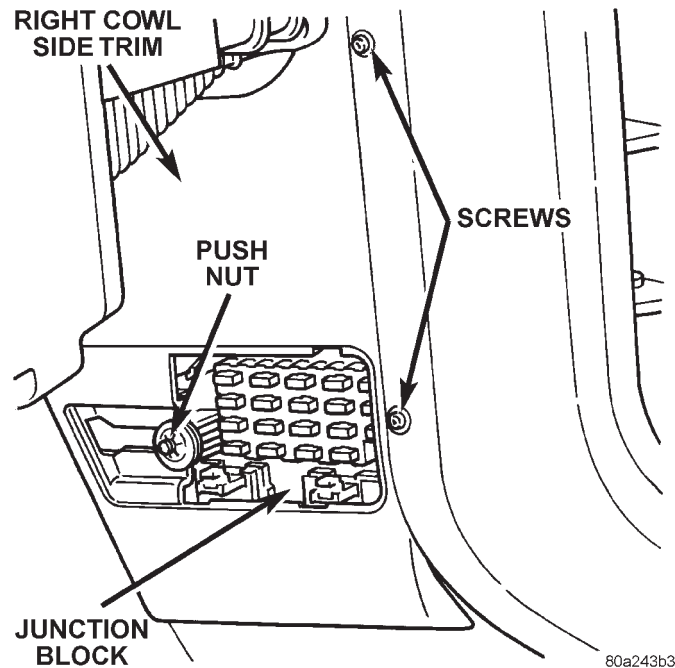


Fig. 22 Right Cowl Side Trim Panel Remove/Install

- (4) Remove the two screws that secure the right cowl side trim panel to the right front door opening trim.
- (5) Remove the right cowl side trim panel from the right cowl side inner panel.
- (6) Unplug all of the wire harness connectors from the junction block cavities.
- (7) Remove the two screws that secure the junction block to the mounting bracket on the right cowl side inner panel.

(8) Remove the junction block from the mounting bracket on the right cowl side inner panel.

(9) Reverse the removal procedures to install. Tighten the mounting screws to 2.2 N·m (20 in. lbs.).

INSTRUMENT PANEL ASSEMBLY

WARNING: ON VEHICLES EQUIPPED WITH AIR-BAGS, REFER TO GROUP 8M - PASSIVE RESTRAINT SYSTEMS BEFORE ATTEMPTING ANY STEERING WHEEL, STEERING COLUMN, OR INSTRUMENT PANEL COMPONENT DIAGNOSIS OR SERVICE. FAILURE TO TAKE THE PROPER PRECAUTIONS COULD RESULT IN ACCIDENTAL AIR-BAG DEPLOYMENT AND POSSIBLE PERSONAL INJURY.

- (1) Disconnect and isolate the battery negative cable.
- (2) Remove the steering column opening cover and knee blocker from the instrument panel. See Steering Column Opening Cover and Knee Blocker in this group for the procedures.
- (3) Remove the bolts that secure the lower instrument panel reinforcement to the instrument panel armature and remove the reinforcement (Fig. 23).
- (4) Remove the upper and lower steering column shrouds from the steering column. Refer to Group 19 - Steering for the procedures.
- (5) Unplug all of the wire harness connectors from the steering column-mounted components and switches.
- (6) Remove the three nuts that secure the steering column toe plate to the dash panel at the base of the steering column.
- (7) Remove the two nuts that secure the steering column mounting bracket to the studs on the steering column and brake pedal support. Lower the steering column to the floor.
- (8) Remove both cowl side trim panels. Refer to Group 23 - Body for the procedures.
- (9) Unplug the instrument panel to body wire harness connector under the left end of the instrument panel.
- (10) Unplug the brake lamp switch wire harness connector.
- (11) Unplug the instrument panel to heater-A/C housing vacuum harness connector (manual temperature control only) and wire harness connector located under the passenger side end of the instrument panel.
- (12) Unplug the radio antenna coaxial cable connector near the right cowl side panel.
- (13) Unplug all of the instrument panel wire harness connectors from the junction block on the right cowl side panel.

REMOVAL AND INSTALLATION (Continued)

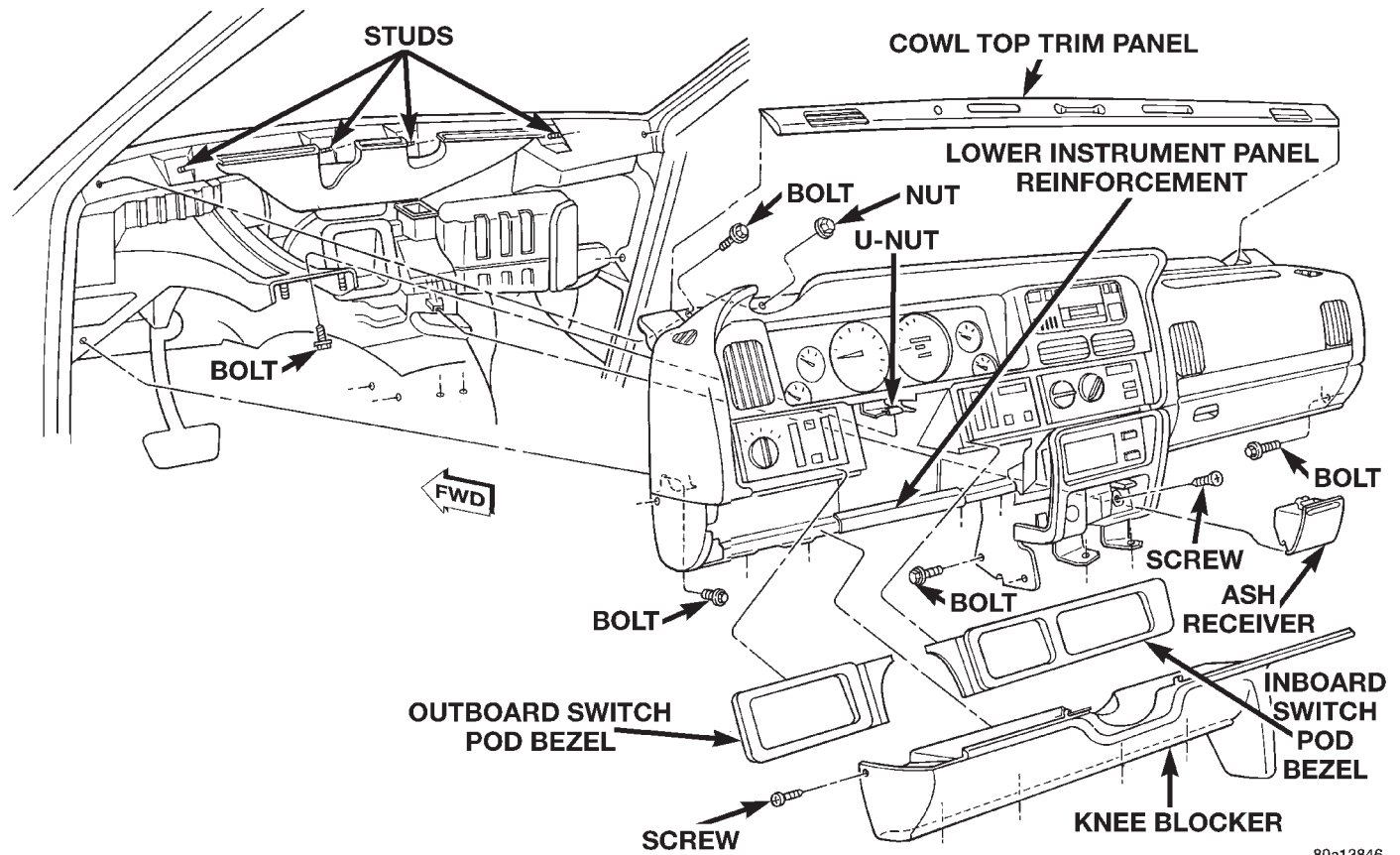


Fig. 23 Instrument Panel Assembly Remove/Install

(14) If the vehicle is so equipped, disconnect the in-car temperature sensor aspirator hose at the coupling near the passenger side of the transmission floor tunnel.

(15) On Left-Hand Drive (LHD) models only, remove the ash receiver and remove the screw in the back of the ash receiver housing that secures the instrument panel armature to the heater-A/C housing.

(16) Pull back the floor carpet on the transmission tunnel from the base of the instrument panel center bezel and remove the two bolts that secure the instrument panel center bracket to the floor.

(17) Remove the two bolts that secure the instrument panel center bracket to the driver side of the transmission floor tunnel.

(18) Remove the bolt that secures the instrument panel armature to the steering column and brake pedal support.

(19) Remove the two bolts that secure the ends of the instrument panel armature to the cowl side inner panels.

(20) Remove the cowl top trim panel from the instrument panel. See Cowl Top Trim Panel in this group for the procedures.

(21) Remove the two bolts that secure the ends of the instrument panel armature to the windshield fence.

(22) Remove the four nuts that secure the top of the instrument panel armature to the studs on the windshield fence.

(23) With the aid of an assistant, lift the instrument panel off of the windshield fence studs and maneuver the assembly out of the vehicle through the passenger side front door.

(24) Reverse the removal procedures to install. Tighten the mounting hardware as follows:

- Instrument panel center bracket to floor pan transmission tunnel fasteners - 28 N·m (250 in. lbs.)
- Instrument panel to windshield fence bolts and nuts - 12 N·m (105 in. lbs.)
- Instrument panel to cowl side inner panel bolts - 12 N·m (105 in. lbs.)
- Instrument panel to steering column support bolt - 12 N·m (105 in. lbs.)

AUDIO SYSTEMS

CONTENTS

	page		page
GENERAL INFORMATION			
INTRODUCTION	1	RADIO FREQUENCY INTERFERENCE	8
MEMORY SYSTEM	1	RADIO	4
DESCRIPTION AND OPERATION			
ANTENNA	3	REMOTE RADIO SWITCH	4
BODY CONTROL MODULE	2	SPEAKER	6
IGNITION-OFF DRAW FUSE	2	REMOVAL AND INSTALLATION	
RADIO NOISE SUPPRESSION	3	AMPLIFIER	10
RADIO	1	ANTENNA	13
REMOTE RADIO SWITCH	2	RADIO	8
SPEAKER	3	REMOTE RADIO SWITCH	9
DIAGNOSIS AND TESTING			
ANTENNA	7	SOUND BAR	13
AUDIO SYSTEM	4	SPEAKER	10
		SPECIAL TOOLS	
		ANTENNA	15

GENERAL INFORMATION

INTRODUCTION

Following are general descriptions of the major components used in both the standard and optional factory-installed audio systems. Refer to 8W-47 Audio System in Group 8W - Wiring Diagrams for complete circuit descriptions and diagrams.

MEMORY SYSTEM

An electronic memory system is an available option on this model. The memory system is able to store and recall the driver side power seat positions (including power lumbar and recliner positions), and both outside power mirror positions for two drivers. For vehicles with a radio connected to the Chrysler Collision Detection (CCD) data bus network, the memory system is also able to store and recall ten radio station presets (including last station tuned) for two drivers. The memory system will automatically return to all of these settings when the corresponding button (Driver 1 or 2) of the memory switch on the driver side front door trim panel is depressed, or when the doors are unlocked using the corresponding (Driver 1 or 2) Remote Keyless Entry (RKE) transmitter.

The Driver Door Module (DDM) receives hard-wired input from the memory set/select switch on the driver side front door trim panel. The DDM also receives messages on the CCD data bus from the RKE receiver in the Passenger Door Module (PDM) for the memory select function. The DDM processes these inputs and

sends messages to the PDM, the Memory Seat Module (MSM), and the radio (if CCD data bus capable) on the CCD data bus for memory recall.

The CCD data bus network allows the sharing of sensor information. This helps to reduce wire harness complexity, reduce internal controller hardware, and reduce component sensor current loads. At the same time, this system provides increased reliability, enhanced diagnostics, and allows the addition of many new feature capabilities.

This group covers only the conventional diagnostic procedures for the audio system components. For diagnosis of the memory system, the use of a DRB scan tool and the proper Diagnostic Procedures manual are recommended. For additional information on the features and functions of the memory system, refer to the owner's manual in the vehicle glove box.

DESCRIPTION AND OPERATION

RADIO

Available factory-installed radio receivers for this model include an AM/FM/cassette (RAS sales code), an AM/FM/cassette/5-band graphic equalizer with CD changer control feature (RBN sales code), or an AM/FM/CD/cassette/3-band graphic equalizer (RAZ sales code). All factory-installed radio receivers are stereo Electronically Tuned Radios (ETR), and include an electronic digital clock function.

All factory-installed radio receivers, except the RAS model, communicate on the Chrysler Collision

DESCRIPTION AND OPERATION (Continued)

Detection (CCD) data bus network through a separate two-way wire harness connector. The CCD data bus network allows the sharing of sensor information. This helps to reduce wire harness complexity, internal controller hardware, and component sensor current loads. At the same time, this system provides increased reliability, enhanced diagnostics, and allows the addition of many new feature capabilities.

Radios connected to the CCD data bus network in vehicles equipped with the optional Vehicle Information Center (VIC) have a clock synchronization feature. The VIC clock display is automatically updated to the setting shown on the radio clock through a message sent on the CCD data bus by the radio. Refer to Group 8E - Instrument Panel Systems for more information on the VIC module.

In addition, radios connected to the CCD data bus have several audio system functions that can be diagnosed using a DRB scan tool. Refer to the proper Diagnostic Procedures manual for more information on DRB testing of the audio systems.

The radio can only be serviced by an authorized radio repair station. Refer to the latest Warranty Policies and Procedures manual for a current listing of authorized radio repair stations.

For more information on radio features, setting procedures, and control functions refer to the owner's manual in the vehicle glove box.

REMOTE RADIO SWITCH

A remote radio control switch option is available on Grand Cherokee Limited models with the AM/FM/cassette/5-band graphic equalizer with CD changer control feature (RBN sales code), or the AM/FM/CD/cassette/3-band graphic equalizer (RAZ sales code) radio receivers. Two rocker-type switches are mounted on the back (instrument panel side) of the steering wheel spokes. The switch on the left spoke is the seek switch and has seek up, seek down, and preset station advance functions. The switch on the right spoke is the volume control switch and has volume up, and volume down functions.

These switches are resistor multiplexed units that are hard-wired to the Body Control Module (BCM) through the clockspring. The BCM sends the proper messages on the Chrysler Collision Detection (CCD) data bus network to the radio receiver. For diagnosis of the BCM or the CCD data bus, the use of a DRB scan tool and the proper Diagnostic Procedures manual are recommended. For more information on the operation of the remote radio switch controls, refer to the owner's manual in the vehicle glove box.

BODY CONTROL MODULE

A Body Control Module (BCM) is used on this model to control and integrate many of the electronic

functions and features included on the vehicle. The BCM contains a central processing unit and interfaces with other modules in the vehicle on the Chrysler Collision Detection (CCD) data bus network.

The CCD data bus network allows the sharing of sensor information. This helps to reduce wire harness complexity, reduce internal controller hardware, and reduce component sensor current loads. At the same time, this system provides increased reliability, enhanced diagnostics, and allows the addition of many new feature capabilities.

One of the functions and features that the BCM supports and controls, is the remote radio switches on vehicles so equipped. The BCM receives hard-wired resistor multiplexed inputs from the remote radio switches. The programming in the BCM allows it to process those inputs and send the proper messages to the radio over the CCD data bus to control the radio volume, station seek, and preset station advance functions.

The BCM is mounted under the driver side outboard end of the instrument panel, behind the instrument panel support armature and below the outboard switch pod. Refer to Group 8E - Instrument Panel Systems for the removal and installation procedures. For diagnosis of the BCM or the CCD data bus, the use of a DRB scan tool and the proper Diagnostic Procedures manual are recommended. The BCM can only be serviced by an authorized electronic repair station. Refer to the latest Warranty Policies and Procedures manual for a current listing of authorized electronic repair stations.

IGNITION-OFF DRAW FUSE

All vehicles are equipped with an Ignition-Off Draw (IOD) fuse that is removed when the vehicle is shipped from the factory. This fuse feeds various accessories that require battery current when the ignition switch is in the Off position, including the clock and radio station preset memory functions. The fuse is removed to prevent battery discharge during vehicle storage.

When removing or installing the IOD fuse, it is important that the ignition switch be in the Off position. Failure to place the ignition switch in the Off position can cause the radio display to become scrambled when the IOD fuse is removed and replaced. Removing and replacing the IOD fuse again, with the ignition switch in the Off position, will correct the scrambled display condition.

The IOD fuse should be checked if the radio is inoperative. The IOD fuse is located in the Power Distribution Center (PDC). Refer to the PDC label for IOD fuse identification and location.

DESCRIPTION AND OPERATION (Continued)

SPEAKER

The only speaker system offered with the base AM/FM/cassette radio receiver (RAS sales code) includes four full-range speakers, one mounted in each of the four doors. This is also the standard equipment speaker system offered with the AM/FM/CD/cassette/3-band graphic equalizer (RAZ sales code).

Optional for the RAZ sales code radio, and standard for all other radios (except RAS sales code) is the Infinity Gold premium speaker and 120 watt amplifier package. This package uses an Infinity amplifier mounted on the floor beneath the rear seat cushion on the driver side of the vehicle. The package includes an Infinity coaxial full-range speaker mounted in each rear door, an Infinity woofer speaker mounted in each front door, and an Infinity tweeter mounted at each outboard end of the instrument panel top cover.

The standard equipment speaker system for the Limited Plus package is the Infinity Gold premium speaker and 180 watt amplifier package. In addition to the increased amplifier output, this package adds a sound bar mounted on the inside roof headliner, just forward of the liftgate opening. This package uses the same Infinity speakers as the 120 watt amplifier package in the front doors and the instrument panel, but uses Infinity woofers in the rear doors. In addition, the sound bar houses two Infinity mid-range speakers and two Infinity tweeters, for a total of ten system speakers.

ANTENNA

All models use a fixed-length stainless steel rod-type antenna mast, installed on the right front fender of the vehicle. The antenna mast is connected to the center wire of the coaxial antenna cable, and is not grounded to any part of the vehicle.

To eliminate static, the antenna base must have a good ground. The coaxial antenna cable shield (the outer wire mesh of the cable) is grounded to the antenna base and the radio chassis.

The antenna coaxial cable has an additional disconnect, located near the right end of the instrument panel at the right cowl side inner panel. This additional disconnect allows the instrument panel assembly to be removed and installed without removing the radio.

The factory-installed Electronically Tuned Radios (ETRs) automatically compensate for radio antenna trim. Therefore, no antenna trimmer adjustment is required or possible when replacing the receiver or the antenna.

RADIO NOISE SUPPRESSION

Radio Frequency Interference (RFI) and Electro-Magnetic Interference (EMI) noise suppression is accomplished primarily through circuitry internal to the radio receivers. These internal suppression devices are only serviced as part of the radio receiver.

External suppression devices that are serviced, and should be checked in the case of RFI or EMI noise complaints, include the following:

- Radio antenna base ground
- Radio chassis ground wire, strap, or bracket
- Engine-to-body ground strap (if the vehicle is so equipped)
- Cab-to-bed ground strap (if the vehicle is so equipped)
- Heater core ground strap (if the vehicle is so equipped)
- Resistor-type spark plugs
- Radio suppression-type secondary ignition wiring.

In addition, if the source of RFI or EMI noise is identified as a component on the vehicle (i.e., generator, blower motor, etc.), the ground path for that component should be checked. If excessive resistance is found in that circuit, repair that circuit as required before considering any component replacement.

If the source of the noise is identified as two-way mobile radio or telephone equipment, check the equipment installation for the following:

- Power connections should be made directly to the battery, and fused as closely to the battery as possible.
- The antenna should be mounted on the roof or toward the rear of the vehicle. Remember that magnetic antenna mounts on the roof panel can adversely affect the operation of an overhead console compass, if the vehicle is so equipped.
- The antenna cable should be fully shielded coaxial cable, should be as short as is practical, and should be routed away from the factory-installed vehicle wire harnesses whenever possible.
- The antenna and cable must be carefully matched to ensure a low Standing Wave Ratio (SWR).

Fleet vehicles are available with an extra-cost RFI-suppressed Powertrain Control Module (PCM). This unit reduces interference generated by the PCM on some radio frequencies used in two-way radio communications. However, this unit will not resolve complaints of RFI in the commercial AM or FM radio frequency ranges.

DIAGNOSIS AND TESTING

AUDIO SYSTEM

WARNING: ON VEHICLES EQUIPPED WITH AIR-BAGS, REFER TO GROUP 8M - PASSIVE RESTRAINT SYSTEMS BEFORE ATTEMPTING ANY STEERING WHEEL, STEERING COLUMN, OR INSTRUMENT PANEL COMPONENT DIAGNOSIS OR SERVICE. FAILURE TO TAKE THE PROPER PRECAUTIONS COULD RESULT IN ACCIDENTAL AIR-BAG DEPLOYMENT AND POSSIBLE PERSONAL INJURY.

RADIO

If the vehicle is equipped with remote radio switches located on the backs of the steering wheel spokes, and the problem being diagnosed is related to one of the symptoms listed below, be certain to check the remote radio switches and circuits as described in this group, prior to attempting radio diagnosis or repair.

- Stations changing with no remote radio switch input
- Radio memory presets not working properly
- Volume changes with no remote radio switch input
- Remote radio switch buttons taking on other functions
- CD player skipping tracks
- Remote radio switch inoperative.

For circuit descriptions and diagrams, refer to 8W-47 - Audio System in Group 8W - Wiring Diagrams.

WARNING: ON VEHICLES EQUIPPED WITH AIR-BAGS, REFER TO GROUP 8M - PASSIVE RESTRAINT SYSTEMS BEFORE ATTEMPTING ANY STEERING WHEEL, STEERING COLUMN, OR INSTRUMENT PANEL COMPONENT DIAGNOSIS OR SERVICE. FAILURE TO TAKE THE PROPER PRECAUTIONS COULD RESULT IN ACCIDENTAL AIR-BAG DEPLOYMENT AND POSSIBLE PERSONAL INJURY.

CAUTION: The speaker output of the radio is a "floating ground" system. Do not allow any speaker lead to short to ground, as damage to the radio may result.

(1) Check the fuse(s) in the junction block and the Power Distribution Center (PDC). If OK, go to Step 2. If not OK, repair the shorted circuit or component as required and replace the faulty fuse(s).

(2) Check for battery voltage at the fuse in the PDC. If OK, go to Step 3. If not OK, repair the open circuit to the battery as required.

(3) Turn the ignition switch to the On position. Check for battery voltage at the fuse in the junction block. If OK, go to Step 4. If not OK, repair the open circuit to the ignition switch as required.

(4) Turn the ignition switch to the Off position. Disconnect and isolate the battery negative cable. Remove the radio, but do not unplug the radio wire harness connectors. Check for continuity between the radio chassis and a good ground. There should be continuity. If OK, go to Step 5. If not OK, repair the open radio chassis ground circuit as required.

(5) Connect the battery negative cable. Turn the ignition switch to the On position. Check for battery voltage at the fused ignition switch output (accessory/run) circuit cavity of the left (gray) radio wire harness connector. If OK, go to Step 6. If not OK, repair the open circuit as required.

(6) Turn the ignition switch to the Off position. Check for battery voltage at the fused B(+) circuit cavity of the left (gray) radio wire harness connector. If OK, replace the faulty radio. If not OK, repair the open circuit to the Ignition-Off Draw (IOD) fuse as required.

REMOTE RADIO SWITCH

WARNING: ON VEHICLES EQUIPPED WITH AIR-BAGS, REFER TO GROUP 8M - PASSIVE RESTRAINT SYSTEMS BEFORE ATTEMPTING ANY STEERING WHEEL, STEERING COLUMN, OR INSTRUMENT PANEL COMPONENT DIAGNOSIS OR SERVICE. FAILURE TO TAKE THE PROPER PRECAUTIONS COULD RESULT IN ACCIDENTAL AIR-BAG DEPLOYMENT AND POSSIBLE PERSONAL INJURY.

(1) Disconnect and isolate the battery negative cable. Wait two minutes for the airbag system capacitor to discharge before further service.

(2) Remove the remote radio switch(es) from the steering wheel.

DIAGNOSIS AND TESTING (Continued)

Audio System Diagnosis		
CONDITION	POSSIBLE CAUSE	CORRECTION
NO AUDIO.	<ol style="list-style-type: none"> 1. Fuse faulty. 2. Radio connector faulty. 3. Wiring faulty. 4. Ground faulty. 5. Radio faulty. 6. Speakers faulty. 	<ol style="list-style-type: none"> 1. Check radio fuses in junction block. Replace fuses, if required. 2. Check for loose or corroded radio connector. Repair, if required. 3. Check for battery voltage at radio connector. Repair wiring, if required. 4. Check for continuity between radio chassis and a known good ground. There should be continuity. Repair ground, if required. 5. Exchange or replace radio, if required. 6. See speaker diagnosis, in this group.
NO DISPLAY.	<ol style="list-style-type: none"> 1. Fuse faulty. 2. Radio connector faulty. 3. Wiring faulty. 4. Ground faulty. 5. Radio faulty. 	<ol style="list-style-type: none"> 1. Check radio fuses in junction block. Replace fuses, if required. 2. Check for loose or corroded radio connector. Repair, if required. 3. Check for battery voltage at radio connector. Repair wiring, if required. 4. Check for continuity between radio chassis and a known good ground. There should be continuity. Repair ground, if required. 5. Exchange or replace radio, if required.
CLOCK WILL NOT KEEP SET TIME.	<ol style="list-style-type: none"> 1. Fuse faulty. 2. Radio connector faulty. 3. Wiring faulty. 4. Ground faulty. 5. Radio faulty. 	<ol style="list-style-type: none"> 1. Check ignition-off draw fuse. Replace fuse, if required. 2. Check for loose or corroded radio connector. Repair, if required. 3. Check for battery voltage at radio connector. Repair wiring, if required. 4. Check for continuity between radio chassis and a known good ground. There should be continuity. Repair ground, if required. 5. Exchange or replace radio, if required.
POOR RADIO RECEPTION.	<ol style="list-style-type: none"> 1. Antenna faulty. 2. Ground faulty. 3. Radio faulty. 	<ol style="list-style-type: none"> 1. See antenna diagnosis, in this group. Repair or replace antenna, if required. 2. Check for continuity between radio chassis and a known good ground. There should be continuity. Repair ground, if required. 3. Exchange or replace radio, if required.
NO/POOR TAPE OPERATION.	<ol style="list-style-type: none"> 1. Faulty tape. 2. Foreign objects behind tape door. 3. Dirty cassette tape head. 4. Faulty tape deck. 	<ol style="list-style-type: none"> 1. Insert known good tape and test operation. 2. Remove foreign objects and test operation. 3. Clean head with Mopar Cassette Head Cleaner. 4. Exchange or replace radio, if required.
NO COMPACT DISC OPERATION	<ol style="list-style-type: none"> 1. Faulty CD. 2. Foreign material on CD. 3. Condensation on CD or optics. 4. Faulty CD player. 	<ol style="list-style-type: none"> 1. Insert known good CD and test operation. 2. Clean CD and test operation. 3. Allow temperature of vehicle interior to stabilize and test operation. 4. Exchange or replace radio, if required.

DIAGNOSIS AND TESTING (Continued)

(3) Use an ohmmeter to check the switch resistance as shown in the Remote Radio Switch Test chart.

Remote Radio Switch Test	
Switch Position	Resistance
Volume Up	7320 Ohms
Volume Down	1210 Ohms
Seek Up	4530 Ohms
Seek Down	2050 Ohms
Pre-Set Station Advance	10 Ohms

(4) If the switch resistance checks OK, go to Step 5. If not OK, replace the faulty switch.

(5) Check for continuity between the ground circuit cavity of the switch wire harness connector and a good ground. There should be continuity. If OK, go to Step 6. If not OK, repair the open circuit as required.

(6) Unplug the 24-way white wire harness connector from the Body Control Module (BCM). Check for continuity between the radio control mux circuit cavity of the remote radio switch wire harness connector and a good ground. There should be no continuity. If OK, go to Step 7. If not OK, repair the short circuit as required.

(7) Check for continuity between the radio control mux circuit cavities of the remote radio switch wire harness connector and the BCM wire harness connector. There should be continuity. If OK, refer to the proper Diagnostic Procedures manual to test the BCM and the CCD data bus. If not OK, repair the open circuit as required.

SPEAKER

For circuit descriptions and diagrams, refer to 8W-47 - Audio System in Group 8W - Wiring Diagrams.

WARNING: ON VEHICLES EQUIPPED WITH AIR-BAGS, REFER TO GROUP 8M - PASSIVE RESTRAINT SYSTEMS BEFORE ATTEMPTING ANY STEERING WHEEL, STEERING COLUMN, OR INSTRUMENT PANEL COMPONENT DIAGNOSIS OR SERVICE. FAILURE TO TAKE THE PROPER PRECAUTIONS COULD RESULT IN ACCIDENTAL AIR-BAG DEPLOYMENT AND POSSIBLE PERSONAL INJURY.

CAUTION: The speaker output of the radio is a "floating ground" system. Do not allow any speaker lead to short to ground, as damage to the radio may result.

(1) Turn the ignition switch to the On position. Turn the radio on. Adjust the balance and fader controls to check the performance of each individual speaker. Note the speaker locations that are not performing correctly. Go to Step 2.

(2) Turn the radio off. Turn the ignition switch to the Off position. Disconnect and isolate the battery negative cable. Remove the radio from the instrument panel. If the vehicle is equipped with the Infinity Gold speaker package, also unplug the wire harness connectors at the amplifier. Check both the speaker feed (+) circuit and return (-) circuit cavities for the inoperative speaker location(s) at the radio wire harness connectors for continuity to ground. In each case, there should be no continuity. If OK, go to Step 3. If not OK, repair the shorted speaker circuit(s) as required.

(3) If the vehicle is equipped with the Infinity Gold speaker package, go to Step 6. If the vehicle is equipped with the standard speaker system, check the resistance between the speaker feed (+) circuit and return (-) circuit cavities of the radio wire harness connectors for the inoperative speaker location(s). The meter should read between 3 and 8 ohms (speaker resistance). If OK, go to Step 4. If not OK, go to Step 5.

(4) Install a known good radio. Connect the battery negative cable. Turn the ignition switch to the On position. Turn on the radio and test the speaker operation. If OK, replace the faulty radio. If not OK, turn the radio off, turn the ignition switch to the Off position, disconnect and isolate the battery negative cable, remove the test radio, and go to Step 5.

(5) Unplug the speaker wire harness connector at the inoperative speaker. Check for continuity between the speaker feed (+) circuit cavities of the radio wire harness connector and the speaker wire harness connector. Repeat the check between the speaker return (-) circuit cavities of the radio wire harness connector and the speaker wire harness connector. In each case, there should be continuity. If OK, replace the faulty speaker. If not OK, repair the open circuit(s) as required.

(6) For each inoperative speaker location, check for continuity between the speaker feed (+) circuit cavities of the radio wire harness connectors and the amplifier wire harness connectors. Repeat the check for each inoperative speaker location between the speaker return (-) circuit cavities of the radio wire harness connectors and the amplifier wire harness connectors. In each case, there should be continuity. If OK, go to Step 7. If not OK, repair the open circuit as required.

(7) Check for continuity between the two ground circuit cavities of the amplifier wire harness connector and a good ground. There should be continuity. If

DIAGNOSIS AND TESTING (Continued)

OK, go to Step 8. If not OK, repair the open circuit(s) as required.

(8) Check the amplifier fuse in the junction block. If OK, go to Step 9. If not OK, repair the shorted circuit or component as required and replace the faulty fuse.

(9) Install the radio. Connect the battery negative cable. Check for battery voltage at the amplifier fuse in the junction block. If OK, go to Step 10. If not OK, repair the open circuit to the PDC as required.

(10) Check for battery voltage at the two fused B(+) circuit cavities of the amplifier wire harness connector. If OK, go to Step 11. If not OK, repair the open circuit to the fuse in the junction block as required.

(11) Turn the ignition switch to the On position. Turn the radio on. Check for battery voltage at the radio 12 volt output circuit cavity of the amplifier wire harness connector. If OK, go to Step 12. If not OK, repair the open circuit to the radio as required.

(12) Turn the radio off. Turn the ignition switch to the Off position. Disconnect and isolate the battery negative cable. For each inoperative speaker location, check both the amplified feed (+) circuit and the amplified return (-) circuit cavities of the amplifier wire harness connectors for continuity to ground. In each case there should be no continuity. If OK, go to Step 13. If not OK, repair the short circuit as required.

(13) For each inoperative speaker location, check the resistance between the amplified feed (+) circuit and the amplified return (-) circuit cavities of the amplifier wire harness connectors. The meter should read between 3 and 8 ohms (speaker resistance). If OK, replace the faulty amplifier. If not OK, go to Step 14.

(14) Unplug the speaker wire harness connector at the inoperative speaker. Check for continuity between the amplified feed (+) circuit cavities of the speaker wire harness connector and the amplifier wire harness connector. Repeat the check between the amplified return (-) circuit cavities of the speaker wire harness connector and the amplifier wire harness connector. In each case there should be continuity. If OK, replace the faulty speaker. If not OK, repair the open circuit as required.

ANTENNA

WARNING: ON VEHICLES EQUIPPED WITH AIR-BAGS, REFER TO GROUP 8M - PASSIVE RESTRAINT SYSTEMS BEFORE ATTEMPTING ANY STEERING WHEEL, STEERING COLUMN, OR INSTRUMENT PANEL COMPONENT DIAGNOSIS OR SERVICE. FAILURE TO TAKE THE PROPER PRECAUTIONS COULD RESULT IN ACCIDENTAL AIR-

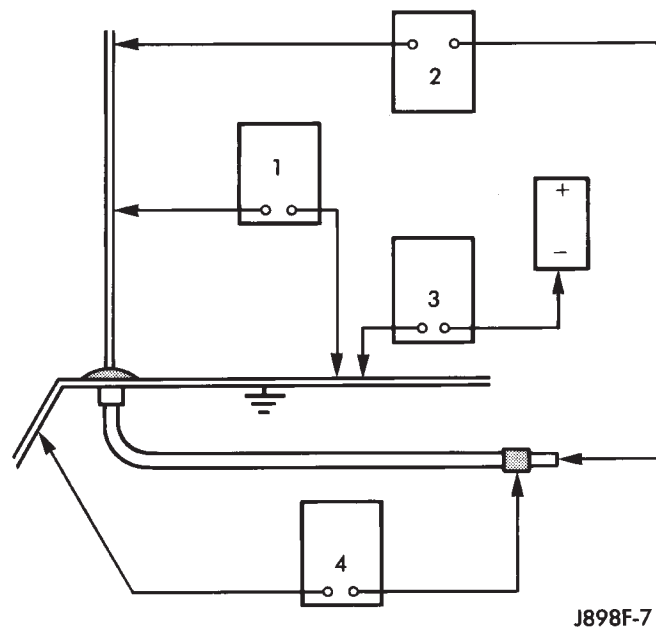
BAG DEPLOYMENT AND POSSIBLE PERSONAL INJURY.

The following four tests are used to diagnose the antenna with an ohmmeter:

- **Test 1** - Mast to ground test
- **Test 2** - Tip-of-mast to tip-of-conductor test
- **Test 3** - Body ground to battery ground test
- **Test 4** - Body ground to coaxial shield test.

The ohmmeter test lead connections for each test are shown in Antenna Tests (Fig. 1).

NOTE: This model has a two-piece antenna coaxial cable. Tests 2 and 4 must be conducted in two steps to isolate a coaxial cable problem; from the coaxial cable connection under the right end of the instrument panel near the right cowl side panel to the antenna base, and then from the coaxial cable connection to the radio chassis connection.



J898F-7

Fig. 1 Antenna Tests

TEST 1

Test 1 determines if the antenna mast is insulated from the base. Proceed as follows:

- (1) Unplug the antenna coaxial cable connector from the radio chassis and isolate.
- (2) Connect one ohmmeter test lead to the tip of the antenna mast. Connect the other test lead to the antenna base. Check for continuity.

(3) There should be no continuity. If continuity is found, replace the faulty or damaged antenna base and cable assembly.

TEST 2

Test 2 checks the antenna for an open circuit as follows:

DIAGNOSIS AND TESTING (Continued)

(1) Unplug the antenna coaxial cable connector from the radio chassis.

(2) Connect one ohmmeter test lead to the tip of the antenna mast. Connect the other test lead to the center pin of the antenna coaxial cable connector.

(3) Continuity should exist (the ohmmeter should only register a fraction of an ohm). High or infinite resistance indicates damage to the base and cable assembly. Replace the faulty base and cable, if required.

TEST 3

Test 3 checks the condition of the vehicle body ground connection. This test should be performed with the battery positive cable removed from the battery. Disconnect both battery cables, the negative cable first. Reconnect the battery negative cable and perform the test as follows:

(1) Connect one ohmmeter test lead to the vehicle fender. Connect the other test lead to the battery negative post.

(2) The resistance should be less than one ohm.

(3) If the resistance is more than one ohm, check the braided ground strap connected to the engine and the vehicle body for being loose, corroded, or damaged. Repair the ground strap connection, if required.

TEST 4

Test 4 checks the condition of the ground between the antenna base and the vehicle body as follows:

(1) Connect one ohmmeter test lead to the vehicle fender. Connect the other test lead to the outer crimp on the antenna coaxial cable connector.

(2) The resistance should be less than one ohm.

(3) If the resistance is more than one ohm, clean and/or tighten the antenna base to fender mounting hardware.

RADIO FREQUENCY INTERFERENCE

WARNING: ON VEHICLES EQUIPPED WITH AIR-BAGS, REFER TO GROUP 8M - PASSIVE RESTRAINT SYSTEMS BEFORE ATTEMPTING ANY STEERING WHEEL, STEERING COLUMN, OR INSTRUMENT PANEL COMPONENT DIAGNOSIS OR SERVICE. FAILURE TO TAKE THE PROPER PRECAUTIONS COULD RESULT IN ACCIDENTAL AIR-BAG DEPLOYMENT AND POSSIBLE PERSONAL INJURY.

Inspect the ground connections at the following:

- Blower motor
- Electric fuel pump
- Generator
- Ignition module
- Wiper motor
- Antenna coaxial ground

- Radio ground
- Body-to-engine braided ground strap (if the vehicle is so equipped).

Clean, tighten, or repair the connections as required.

Also inspect the following secondary ignition system components, as described in Group 8D - Ignition Systems:

- Spark plug wire routing and condition
- Distributor cap and rotor
- Ignition coil
- Spark plugs.

Reroute the spark plug wires or replace the faulty components as required.

REMOVAL AND INSTALLATION

RADIO

WARNING: ON VEHICLES EQUIPPED WITH AIR-BAGS, REFER TO GROUP 8M - PASSIVE RESTRAINT SYSTEMS BEFORE ATTEMPTING ANY STEERING WHEEL, STEERING COLUMN, OR INSTRUMENT PANEL COMPONENT DIAGNOSIS OR SERVICE. FAILURE TO TAKE THE PROPER PRECAUTIONS COULD RESULT IN ACCIDENTAL AIR-BAG DEPLOYMENT AND POSSIBLE PERSONAL INJURY.

(1) Disconnect and isolate the battery negative cable.

(2) Using a trim stick or another suitable wide flat-bladed tool, gently pry around the perimeter edges of both instrument panel switch pod bezels to release the snap clip retainers. Remove both bezels from the instrument panel.

(3) Remove the ten screws that secure the cluster bezel to the instrument panel (Fig. 2).

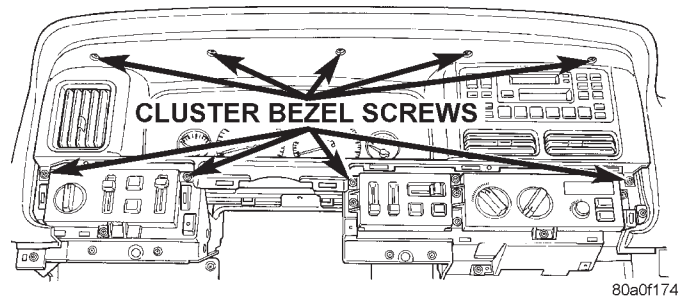


Fig. 2 Cluster Bezel Screws Remove/Install

(4) Pull the cluster bezel rearward and move it to the outboard side of the steering wheel to remove it from the instrument panel.

(5) Remove the two screws that secure the radio face plate to the instrument panel (Fig. 3).

REMOVAL AND INSTALLATION (Continued)

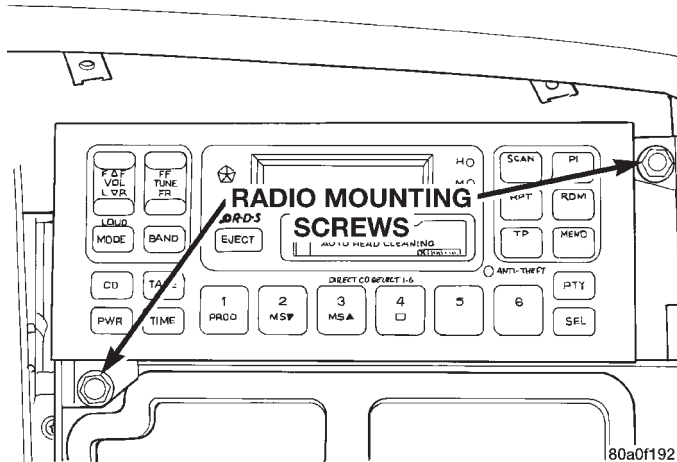


Fig. 3 Radio Remove/Install

(6) Pull the radio out from the instrument panel far enough to access the wire harness connectors and the antenna coaxial cable connector (Fig. 4).

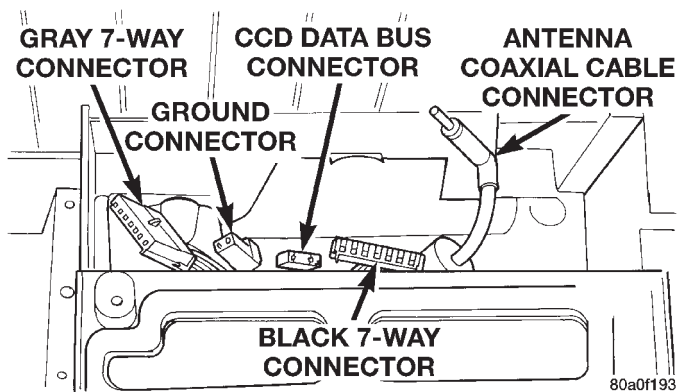


Fig. 4 Radio Connections

(7) Unplug the wire harness connectors and the antenna coaxial cable connector from the rear of the radio.

(8) If the vehicle is so equipped, remove the screw that secures the ground strap to the radio chassis.

(9) Remove the radio from the instrument panel.

(10) Reverse the removal procedures to install. Tighten the radio mounting screws to 5 N·m (45 in. lbs.). Tighten the cluster bezel mounting screws to 2.2 N·m (20 in. lbs.).

REMOTE RADIO SWITCH

WARNING: ON VEHICLES EQUIPPED WITH AIRBAGS, REFER TO GROUP 8M - PASSIVE RESTRAINT SYSTEMS BEFORE ATTEMPTING ANY STEERING WHEEL, STEERING COLUMN, OR INSTRUMENT PANEL COMPONENT DIAGNOSIS OR SERVICE. FAILURE TO TAKE THE PROPER PRECAUTIONS COULD RESULT IN ACCIDENTAL AIRBAG DEPLOYMENT AND POSSIBLE PERSONAL INJURY.

(1) Disconnect and isolate the battery negative cable. Wait two minutes for the airbag system capacitor to discharge before further service.

(2) From the underside of the steering wheel, remove the three screws that secure the driver side airbag module to the steering wheel (Fig. 5).

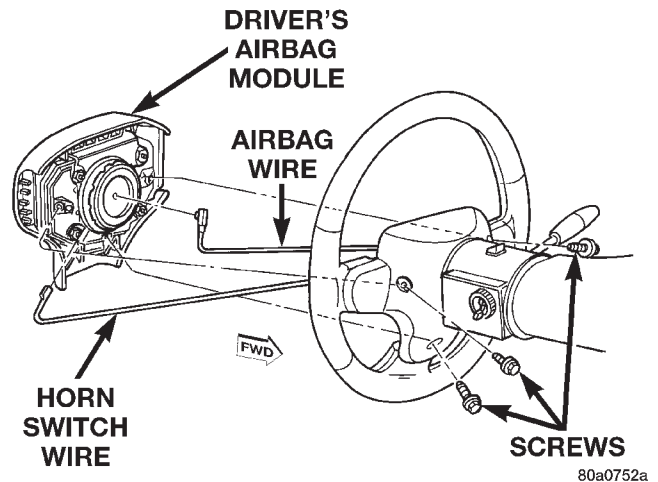


Fig. 5 Driver Side Airbag Module Remove/Install

(3) Pull the airbag module away from the steering wheel far enough to access the wire harness connectors on the back of the airbag module.

(4) Unplug the airbag module and horn switch wire harness connectors from the back of the airbag module.

(5) Remove the driver side airbag module from the vehicle.

(6) Remove the screws that secure the vehicle speed control switches to the steering wheel, and lower the switches from the steering wheel spokes (Fig. 6).

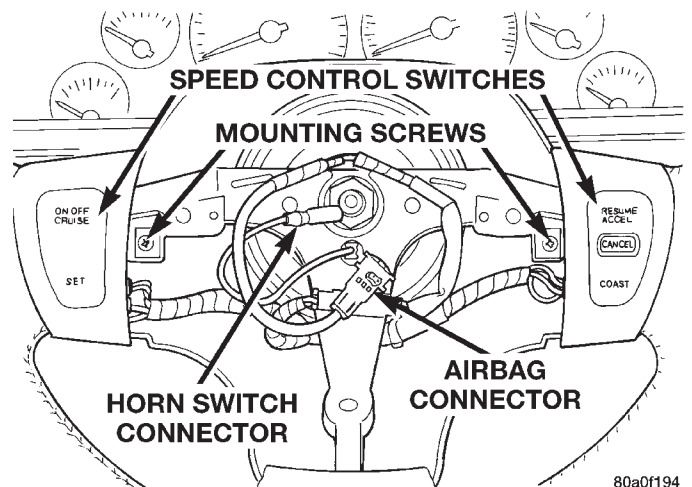


Fig. 6 Vehicle Speed Control Switches Remove/Install

REMOVAL AND INSTALLATION (Continued)

(7) Remove the two screws that secure the remote radio switch to the steering wheel spoke (Fig. 7).

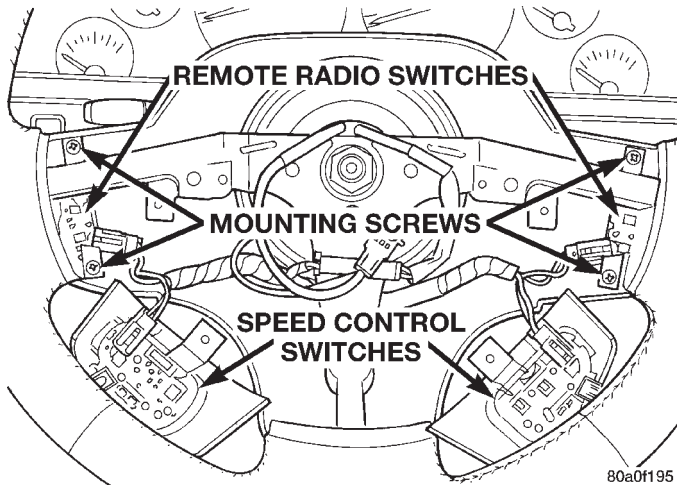


Fig. 7 Remote Radio Switches Remove/Install

(8) Unplug the wire harness connector from the remote radio switch.

(9) Remove the remote radio switch from the steering wheel.

(10) Reverse the removal procedures to install. Tighten the airbag module mounting screws to 10.2 N·m (90 in. lbs.).

AMPLIFIER

(1) Disconnect and isolate the battery negative cable.

(2) Disengage the left rear seat cushion latch by pulling upward on the release strap. Tilt the seat cushion forward.

(3) Lift the carpeting in the under-seat area as required to access the amplifier.

(4) Unplug the two wire harness connectors from the amplifier.

(5) Remove the three screws that secure the amplifier to the floor panel (Fig. 8).

(6) Remove the amplifier from the floor panel.

(7) Reverse the removal procedures to install. Tighten the amplifier mounting screws to 2.8 N·m (25 in. lbs.).

SPEAKER**INSTRUMENT PANEL**

WARNING: ON VEHICLES EQUIPPED WITH AIRBAGS, REFER TO GROUP 8M - PASSIVE RESTRAINT SYSTEMS BEFORE ATTEMPTING ANY STEERING WHEEL, STEERING COLUMN, OR INSTRUMENT PANEL COMPONENT DIAGNOSIS OR SERVICE. FAILURE TO TAKE THE PROPER PRECAUTIONS COULD RESULT IN ACCIDENTAL AIR-

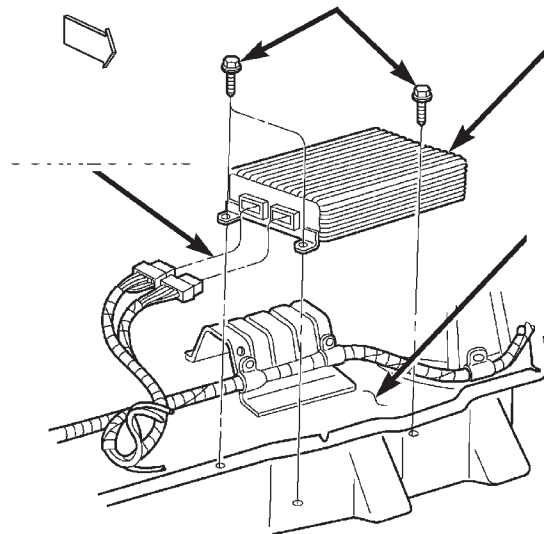


Fig. 8 Amplifier Remove/Install

BAG DEPLOYMENT AND POSSIBLE PERSONAL INJURY.

(1) Disconnect and isolate the battery negative cable.

(2) Using a trim stick or another suitable wide flat-bladed tool, gently pry the cowl top trim panel off of the instrument panel top pad (Fig. 9).

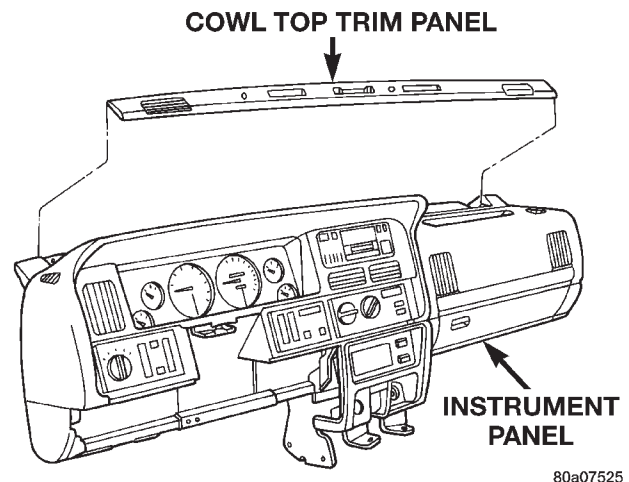


Fig. 9 Cowl Top Trim Remove/Install

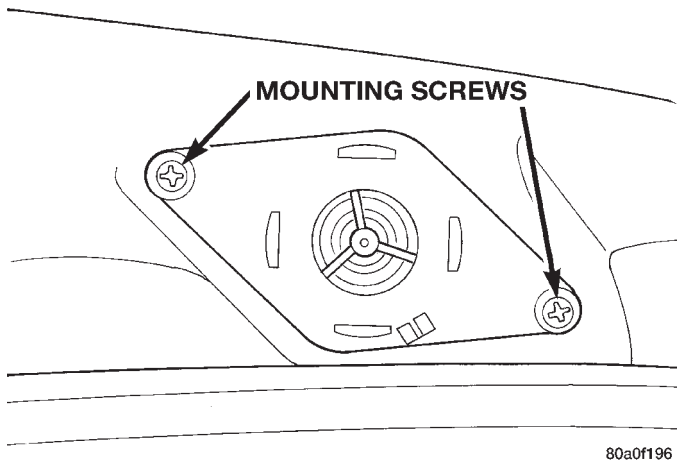
(3) Pull the trim panel up far enough to access and unplug the wire harness connector for the solar sensor, or to remove the solar sensor from the cowl top trim, if the vehicle is so equipped.

(4) Remove the cowl top trim panel from the instrument panel.

(5) Unplug the speaker wire harness connector.

(6) Remove the two screws that secure the speaker to the instrument panel (Fig. 10).

REMOVAL AND INSTALLATION (Continued)



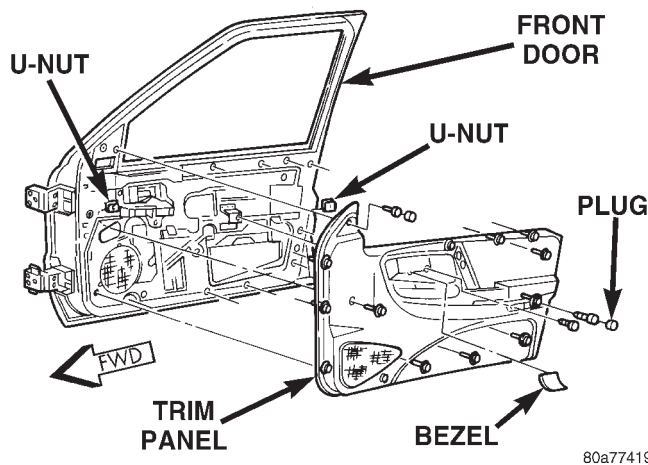
80a0f196

Fig. 10 Instrument Panel Speaker Remove/Install

- (7) Remove the speaker from the instrument panel.
- (8) Reverse the removal procedures to install. Tighten the speaker mounting screws to 1.1 N·m (10 in. lbs.).

FRONT DOOR

- (1) Disconnect and isolate the battery negative cable.
- (2) Remove the bezel near the inside door latch release handle by inserting a straight-bladed screwdriver in the notched end of the bezel and prying gently upwards.
- (3) Remove the screw located beneath the bezel that secures the front door trim panel to the inner door panel (Fig. 11).



80a77419

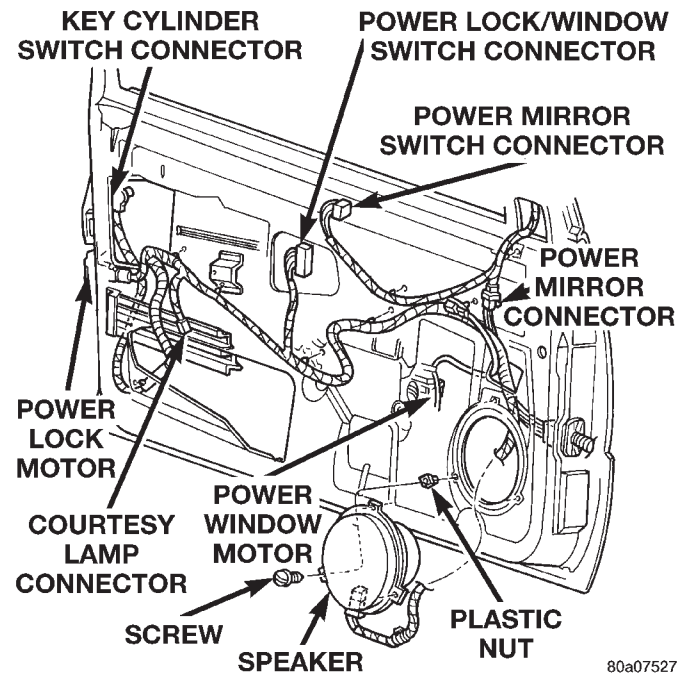
Fig. 11 Front Door Trim Panel Remove/Install

- (4) Remove the trim cap and screw near the rear of the front door armrest.

- (5) Remove the trim cap and screw at the upper front corner of the front door trim panel.
- (6) Remove the screw located above the front door speaker grille on the front door trim panel.
- (7) Using a trim stick or another suitable wide flat-bladed tool, gently pry the front door trim panel away from the door around the perimeter to release the trim panel retainers.

NOTE: To aid in the removal of the trim panel, start at the bottom of the panel.

- (8) Pull the front door trim panel away from the inner door panel far enough to access and unplug the wire harness connectors from the door module and, if the vehicle is so equipped, from the front door courtesy lamp.
- (9) Remove the three screws that secure the speaker to the lower front corner of the inner door panel (Fig. 12).



80a07527

Fig. 12 Front Door Speaker Remove/Install

- (10) Pull the speaker away from the inner door panel far enough to access and unplug the speaker wire harness connector.
- (11) Remove the speaker from the door.
- (12) Reverse the removal procedures to install. Tighten the hardware as follows:
 - Speaker mounting screws - 1.1 N·m (10 in. lbs.)
 - Trim panel mounting screws - 1.3 N·m (12 in. lbs.).

REMOVAL AND INSTALLATION (Continued)**REAR DOOR**

(1) Disconnect and isolate the battery negative cable.

(2) Remove the bezel near the inside door latch release handle by inserting a straight-bladed screwdriver in the notched end of the bezel and prying gently upwards.

(3) Remove the screw located beneath the bezel that secures the rear door trim panel to the inner door panel (Fig. 13).

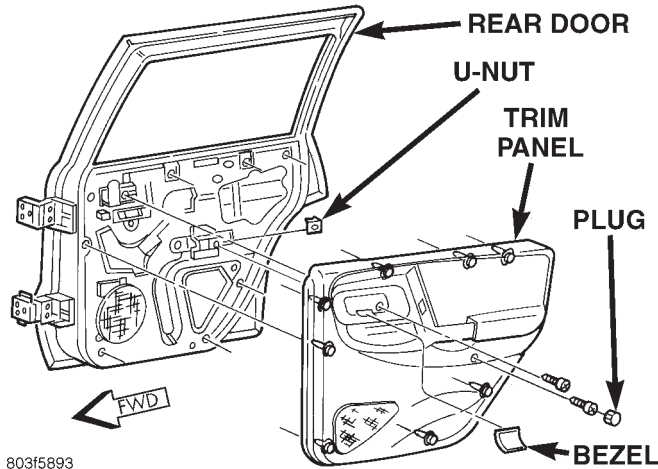


Fig. 13 Rear Door Trim Panel Remove/Install

(4) Remove the trim cap and screw near the rear of the rear door armrest.

(5) Using a trim stick or another suitable wide flat-bladed tool, gently pry the rear door trim panel away from the door around the perimeter to release the trim panel retainers.

NOTE: To aid in the removal of the trim panel, start at the bottom of the panel.

(6) Pull the rear door trim panel away from the inner door panel far enough to access and unplug the wire harness connector from the power window switch.

(7) Remove the three screws that secure the speaker to the lower front corner of the inner door panel (Fig. 14).

(8) Pull the speaker away from the inner door panel far enough to access and unplug the speaker wire harness connector.

(9) Remove the speaker from the door.

(10) Reverse the removal procedures to install. Tighten the hardware as follows:

- Speaker mounting screws - 1.1 N·m (10 in. lbs.)
- Trim panel mounting screws - 1.3 N·m (12 in. lbs.).

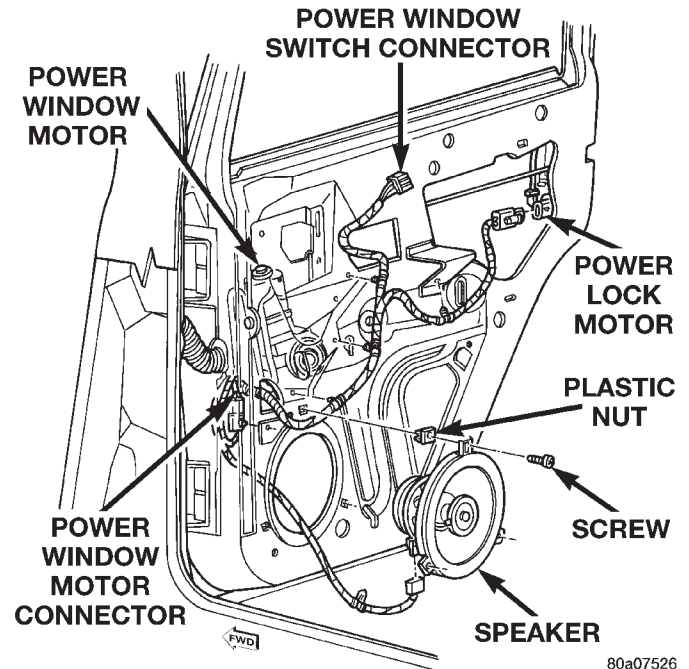


Fig. 14 Rear Door Speaker Remove/Install

SOUND BAR**TWEETER**

(1) Remove the sound bar from the vehicle. See Sound Bar in this group for the procedures.

(2) Unplug the sound bar wire harness connector from the tweeter.

(3) From the inside of the sound bar, use a pair of side cutters to cut and remove the push-nut type retainer that secures the tweeter to the sound bar (Fig. 15).

(4) From the inside of the sound bar, push the tweeter out of the mounting hole.

(5) Reverse the removal procedures to install. Always use a new push-nut retainer to secure the tweeter in the sound bar.

WOOFER

(1) Remove the sound bar from the vehicle. See Sound Bar in this group for the procedures.

(2) Unplug the sound bar wire harness connector from the woofer.

(3) From the inside of the sound bar, straighten the four tabs that secure the speaker grille to the sound bar (Fig. 15).

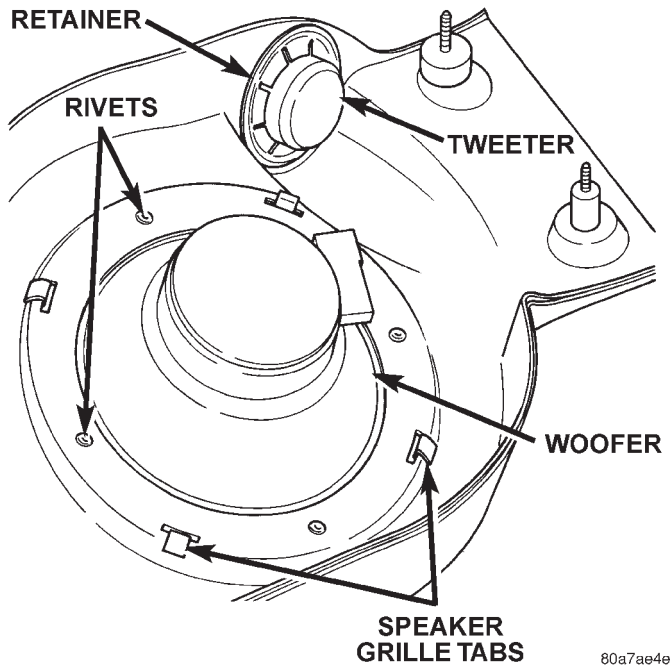
(4) From the outside of the sound bar, gently remove the speaker grille.

(5) Carefully drill out the four rivets that secure the woofer to the sound bar.

(6) Remove the woofer from the sound bar.

(7) Reverse the removal procedures to install. Always use new rivets installed from the inside of the sound bar to secure the woofer.

REMOVAL AND INSTALLATION (Continued)

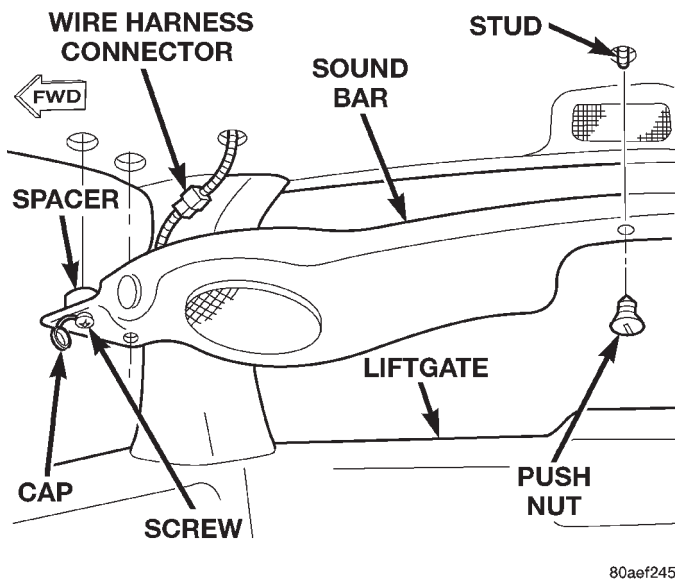


80a7ae4e

Fig. 15 Sound Bar Speakers Remove/Install

SOUND BAR

- (1) Disconnect and isolate the battery negative cable.
- (2) Gently pry at the perimeter edges of each of the two snap-fit screw covers located on each end of the sound bar to uncover the screw heads (Fig. 16).



80aef245

Fig. 16 Sound Bar Remove/Install

(3) Remove the four screws that secure each end of the sound bar to the rear roof rail reinforcements.

(4) Use a straight-bladed screw driver to unscrew the push nut that secures the center of the sound bar to the sound bar bracket stud.

(5) Lower the sound bar far enough to access and unplug the wire harness connector near the right end of the sound bar.

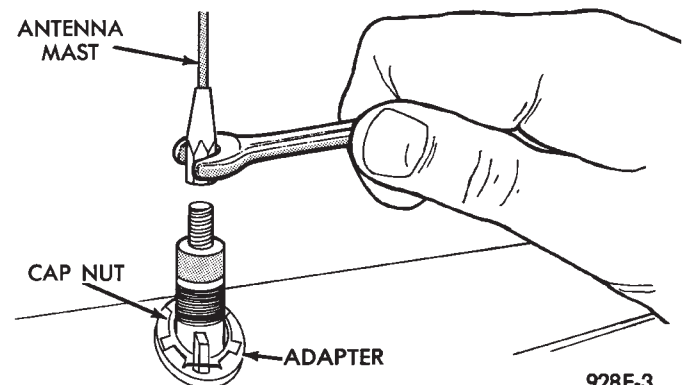
(6) Remove the sound bar from the vehicle.

(7) Reverse the removal procedures to install. When installing the sound bar, push the push nut through the center sound bar mounting hole onto the mounting stud using finger pressure. Be certain that a spacer is in place on each of the four mounting screws between the sound bar and the rear roof rail reinforcements. Tighten the mounting screws to 1.7 N-m (15 in. lbs.).

ANTENNA

WARNING: ON VEHICLES EQUIPPED WITH AIRBAGS, REFER TO GROUP 8M - PASSIVE RESTRAINT SYSTEMS BEFORE ATTEMPTING ANY STEERING WHEEL, STEERING COLUMN, OR INSTRUMENT PANEL COMPONENT DIAGNOSIS OR SERVICE. FAILURE TO TAKE THE PROPER PRECAUTIONS COULD RESULT IN ACCIDENTAL AIRBAG DEPLOYMENT AND POSSIBLE PERSONAL INJURY.

- (1) Disconnect and isolate the battery negative cable.
- (2) Remove the right front fender inner liner. Refer to Front Fender in Group 23 - Body for the procedures.
- (3) Unscrew the antenna mast from the antenna body (Fig. 17).



928F-3

Fig. 17 Antenna Mast Remove/Install - Typical

REMOVAL AND INSTALLATION (Continued)

(4) Remove the antenna cap nut and adapter using an antenna nut wrench (Special Tool C-4816) (Fig. 18).

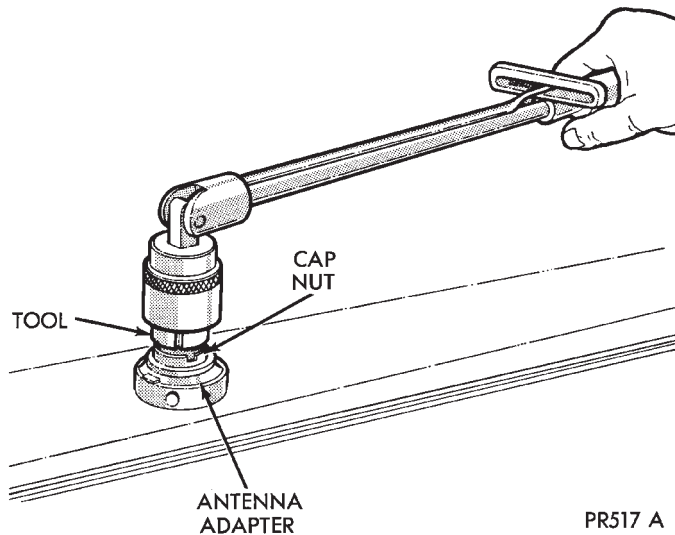


Fig. 18 Antenna Cap Nut and Adapter Remove/Install - Typical

(5) Lower the antenna body and cable assembly through the top of the fender far enough to access the antenna body by reaching up into the rear of the right front fender wheel housing (Fig. 19).

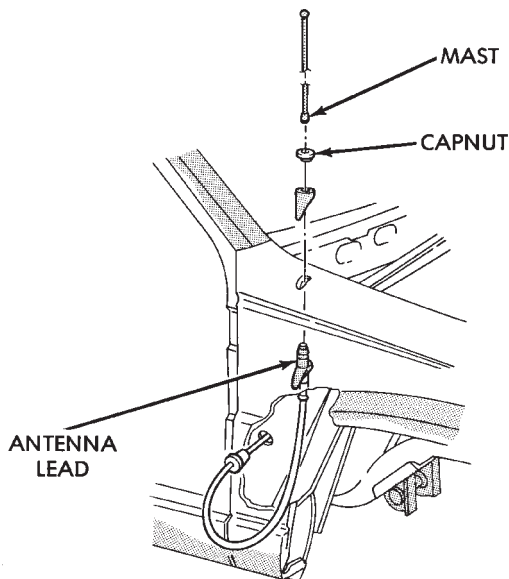


Fig. 19 Antenna Body and Cable Remove/Install

(6) Remove the fuse access panel by unsnapping it from the right cowl side trim panel.

(7) Remove the push nut that secures the right cowl side trim panel to the junction block stud (Fig. 20).

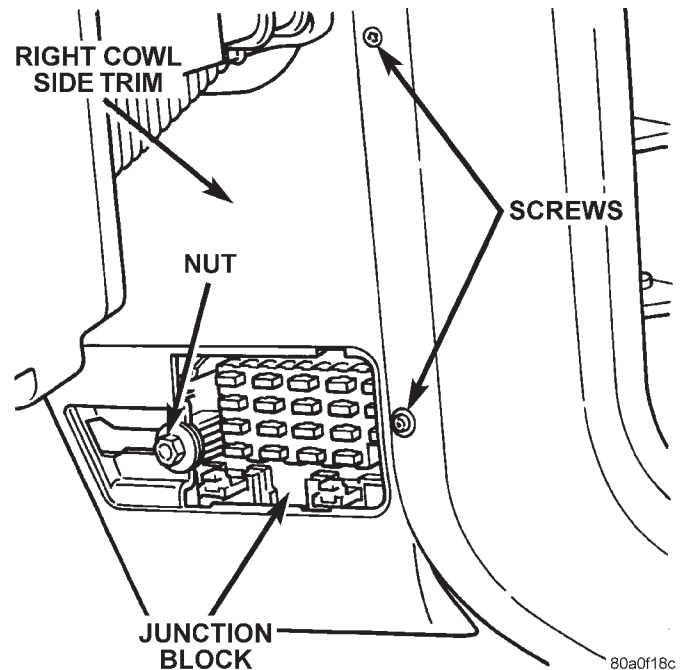


Fig. 20 Right Cowl Side Trim Panel Remove/Install

(8) Remove the two screws that secure the right cowl side trim panel to the right front door opening trim.

(9) Remove the right cowl side trim panel from the right cowl side inner panel.

(10) Reach under the right end of the instrument panel to unplug the coaxial cable connector near the junction block. Unplug the connector by pulling it apart while twisting the metal connector halves (Fig. 21). Do not pull on the cable.

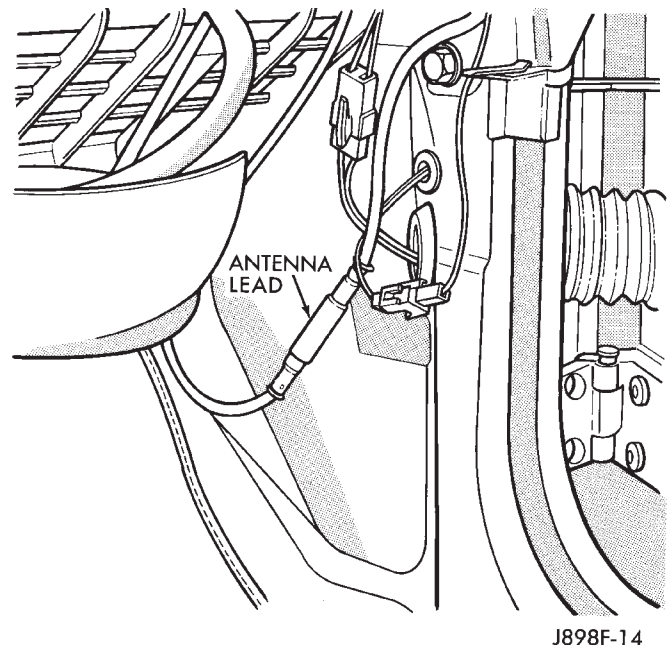


Fig. 21 Antenna Coaxial Cable Connector - Typical

REMOVAL AND INSTALLATION (Continued)

(11) Reach up into the rear of the right front fender wheel housing to disengage the coaxial cable grommet from the hole in the right cowl side outer panel.

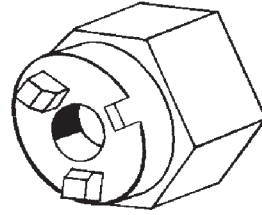
(12) Pull the coaxial cable out through the right cowl side outer panel.

(13) Remove the antenna body and cable from the vehicle.

(14) Reverse the removal procedures to install. Tighten the antenna cap nut to 8 N·m (70 in. lbs.). Tighten the antenna mast to 3.3 N·m (30 in. lbs.).

SPECIAL TOOLS

ANTENNA



Antenna Nut Wrench C-4816

HORN SYSTEMS

CONTENTS

	page		page
GENERAL INFORMATION		HORN SWITCH	3
INTRODUCTION	1	HORN	3
DESCRIPTION AND OPERATION		REMOVAL AND INSTALLATION	
BODY CONTROL MODULE	1	HORN RELAY	3
HORN RELAY	1	HORN SWITCH	4
HORN SWITCH	1	HORN	4
HORN	1		
DIAGNOSIS AND TESTING			
HORN RELAY	2		

GENERAL INFORMATION

INTRODUCTION

Following are general descriptions of the major components in the factory-installed horn systems. Refer to 8W-41 - Horns/Cigar Lighter in Group 8W - Wiring Diagrams for complete circuit descriptions and diagrams.

DESCRIPTION AND OPERATION

HORN RELAY

The horn relay is a International Standards Organization (ISO) micro-relay. The terminal designations and functions are the same as a conventional ISO relay. However, the micro-relay terminal orientation (or footprint) is different, current capacity is lower, and the relay case dimensions are smaller than those of the conventional ISO relay.

The horn relay is a electromechanical device that switches battery current to the horn when the horn switch grounds the relay coil. See the Diagnosis and Testing section of this group for more information on the operation of the horn relay.

The horn relay is located in the Power Distribution Center (PDC), in the engine compartment. Refer to the PDC label for relay identification and location.

If a problem is encountered with a continuously sounding horn, it can usually be quickly resolved by removing the horn relay from the PDC until further diagnosis is completed.

The horn relay cannot be repaired and, if faulty or damaged, it must be replaced.

HORN SWITCH

A center-blow, resistive membrane-type horn switch is installed on the back side of the driver side airbag module trim cover in the center of the steering wheel. When the center area of the airbag trim cover is depressed, the horn switch completes a circuit to ground for the coil side of the horn relay. The steering wheel and steering column must be properly grounded for the horn switch to function.

The horn switch is only serviced as a part of the airbag module trim cover. If the horn switch should fail, or if the airbag is deployed, the airbag module trim cover and horn switch must be replaced as a unit.

HORN

Dual-note, electromagnetic diaphragm-type horns are standard equipment on this model. The horns are secured next to each other on a bracket beneath the right radiator closure extension panel and forward of the right front inner wheelhouse.

The horns are connected in parallel. Both horns are grounded through their wire harness connector and circuit to an eyelet bolted to the right inner fender shield near the Power Distribution Center (PDC), and they receive battery feed through the closed contacts of the horn relay.

The horns cannot be repaired or adjusted and, if faulty or damaged, they must be replaced.

BODY CONTROL MODULE

A Body Control Module (BCM) is used on this model to control and integrate many of the electronic functions and features included on the vehicle. The BCM contains a central processing unit and interfaces with other modules in the vehicle on the Chrysler Collision Detection (CCD) data bus network.

DESCRIPTION AND OPERATION (Continued)

The CCD data bus network allows the sharing of sensor information. This helps to reduce wire harness complexity, reduce internal controller hardware, and reduce component sensor current loads. At the same time, this system provides increased reliability, enhanced diagnostics, and allows the addition of many new feature capabilities.

The horn system is one of the outputs of the BCM. The BCM is programmed to energize or de-energize the horn relay in response to certain inputs from the Vehicle Theft Security System (VTSS) and the Remote Keyless Entry (RKE) system. Refer to Group 8P - Power Lock Systems for more information on the RKE system. Refer to Group 8Q - Vehicle Theft/Security Systems for more information on the VTSS.

The BCM is mounted under the driver side outboard end of the instrument panel, behind the instrument panel support armature and below the outboard switch pod. Refer to Group 8E - Instrument Panel Systems for the removal and installation procedures. For diagnosis of the BCM or the CCD data bus, the use of a DRB scan tool and the proper Diagnostic Procedures manual are recommended. The BCM can only be serviced by an authorized electronic repair station. Refer to the latest Warranty Policies and Procedures manual for a current listing of authorized electronic repair stations.

DIAGNOSIS AND TESTING**HORN RELAY**

For circuit descriptions and diagrams, refer to 8W-41 - Horns/Cigar Lighter in Group 8W - Wiring Diagrams.

WARNING: ON VEHICLES EQUIPPED WITH AIR-BAGS, REFER TO GROUP 8M - PASSIVE RESTRAINT SYSTEMS BEFORE ATTEMPTING ANY STEERING WHEEL, STEERING COLUMN, OR INSTRUMENT PANEL COMPONENT DIAGNOSIS OR SERVICE. FAILURE TO TAKE THE PROPER PRECAUTIONS COULD RESULT IN ACCIDENTAL AIR-BAG DEPLOYMENT AND POSSIBLE PERSONAL INJURY.

RELAY TEST

The horn relay (Fig. 1) is located in the Power Distribution Center (PDC) in the engine compartment. Refer to the PDC label for horn relay identification and location.

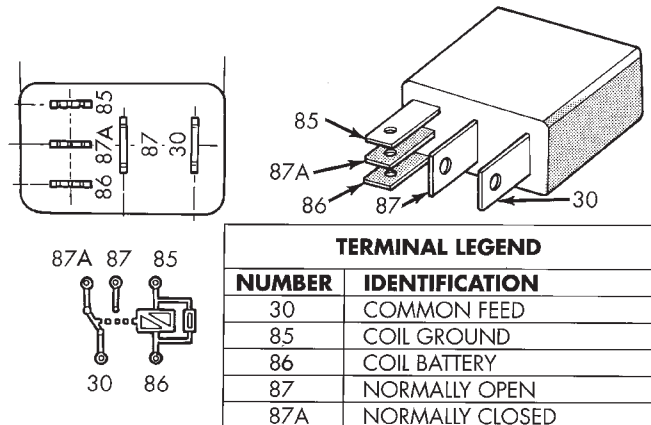
Remove the horn relay from the PDC as described in this group to perform the following tests:

(1) A relay in the de-energized position should have continuity between terminals 87A and 30, and

no continuity between terminals 87 and 30. If OK, go to Step 2. If not OK, replace the faulty relay.

(2) Resistance between terminals 85 and 86 (electromagnet) should be 75 ± 5 ohms. If OK, go to Step 3. If not OK, replace the faulty relay.

(3) Connect a battery to terminals 85 and 86. There should now be continuity between terminals 30 and 87, and no continuity between terminals 87A and 30. If OK, see the Relay Circuit Test in this group. If not OK, replace the faulty relay.



9514-16

Fig 1. Horn Relay**RELAY CIRCUIT TEST**

(1) The relay common feed terminal cavity (30) is connected to battery voltage and should be hot at all times. If OK, go to Step 2. If not OK, repair the open circuit to the PDC fuse as required.

(2) The relay normally closed terminal (87A) is connected to terminal 30 in the de-energized position, but is not used for this application. Go to Step 3.

(3) The relay normally open terminal (87) is connected to the common feed terminal (30) in the energized position. This terminal supplies battery voltage to the horn(s). There should be continuity between the cavity for relay terminal 87 and the horn relay output circuit cavity of each horn wire harness connector at all times. If OK, go to Step 4. If not OK, repair the open circuit to the horn(s) as required.

(4) The coil battery terminal (86) is connected to the electromagnet in the relay. It is connected to battery voltage and should be hot at all times. Check for battery voltage at the cavity for relay terminal 86. If OK, go to Step 5. If not OK, repair the open circuit to the PDC fuse as required.

(5) The coil ground terminal (85) is connected to the electromagnet in the relay. It is grounded through the horn switch when the horn switch is depressed. It can also be grounded by the Body Control Module (BCM) in response to inputs from the Vehicle Theft Security System (VTSS) or the Remote Keyless Entry (RKE) system. Check for continuity to

DIAGNOSIS AND TESTING (Continued)

ground at the cavity for relay terminal 85. There should be continuity with the horn switch depressed, and no continuity with the horn switch released. If not OK, see the diagnosis for the Horn Switch in this group.

HORN SWITCH

For circuit descriptions and diagrams, refer to 8W-41 - Horns/Cigar Lighter in Group 8W - Wiring Diagrams.

WARNING: ON VEHICLES EQUIPPED WITH AIRBAGS, REFER TO GROUP 8M - PASSIVE RESTRAINT SYSTEMS BEFORE ATTEMPTING ANY STEERING WHEEL, STEERING COLUMN, OR INSTRUMENT PANEL COMPONENT DIAGNOSIS OR SERVICE. FAILURE TO TAKE THE PROPER PRECAUTIONS COULD RESULT IN ACCIDENTAL AIRBAG DEPLOYMENT AND POSSIBLE PERSONAL INJURY.

(1) Disconnect and isolate the battery negative cable. Remove the steering column opening cover/knee blocker from the instrument panel. Refer to Steering Column Opening Cover and Knee Blocker in Group 8E - Instrument Panel Systems for the procedures.

(2) Check for continuity between the metal steering column jacket and a good ground. There should be continuity. If OK, go to Step 3. If not OK, refer to Steering Column in Group 19 - Steering for the proper installation of the steering column mounting hardware.

(3) Remove the driver side airbag module from the steering wheel. Refer to Airbag Module in Group 8M - Passive Restraint Systems for the procedures. Unplug the horn switch wire harness connectors from the airbag module.

(4) Unplug the Body Control Module (BCM) wire harness connector B (white). Unplug the horn relay from the Power Distribution Center (PDC). Check for continuity between the steering column half of the horn switch feed wire harness connector and a good ground. There should be no continuity. If OK, go to Step 5. If not OK, repair the short circuit as required.

(5) Check for continuity between the steering column half of the horn switch feed wire harness connector and the horn relay control circuit cavity for the horn relay in the PDC. There should be continuity. If OK, go to Step 6. If not OK, repair the open circuit as required.

(6) Check for continuity between the horn switch feed wire and the horn switch ground wire on the airbag module. There should be no continuity. If OK, go to Step 7. If not OK, replace the faulty horn switch.

(7) Depress the center of the airbag module trim cover and check for continuity between the horn switch feed wire and the horn switch ground wire on the airbag module. There should now be continuity. If not OK, replace the faulty horn switch.

HORN

For circuit descriptions and diagrams, refer to 8W-41 - Horns/Cigar Lighter in Group 8W - Wiring Diagrams.

(1) Unplug the horn wire harness connectors. Measure the resistance between the ground circuit cavity of the horn wire harness connectors and a good ground. There should be no measurable resistance. If OK, go to Step 2. If not OK, repair the circuit to ground as required.

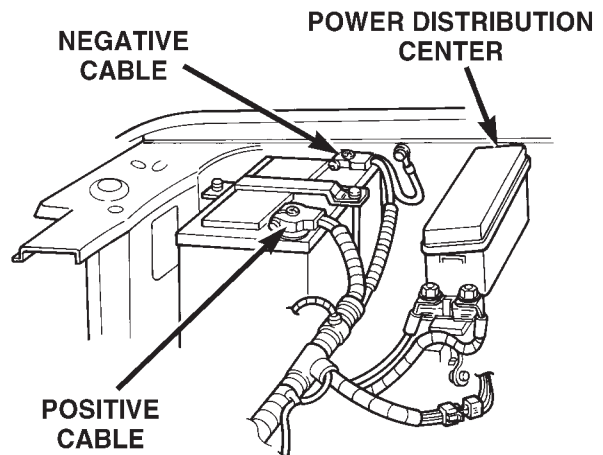
(2) With the horn wire harness connectors still unplugged, depress the horn switch. There should be battery voltage at the horn relay output circuit cavity of the horn wire harness connectors. If OK, replace the faulty horn(s). If not OK, repair the open circuit to the horn relay as required.

REMOVAL AND INSTALLATION

HORN RELAY

(1) Disconnect and isolate the battery negative cable.

(2) Remove the cover from the Power Distribution Center (PDC) (Fig. 2).



80a7233a

Fig. 2 Power Distribution Center

(3) Refer to the label on the PDC for horn relay identification and location.

(4) Unplug the horn relay from the PDC.

(5) Install the horn relay by aligning the relay terminals with the cavities in the PDC and pushing the relay firmly into place.

(6) Install the PDC cover.

(7) Connect the battery negative cable.

REMOVAL AND INSTALLATION (Continued)

- (8) Test the relay operation.

HORN SWITCH

WARNING: ON VEHICLES EQUIPPED WITH A DRIVER SIDE AIRBAG, THE HORN SWITCH IS INTEGRAL TO THE AIRBAG MODULE TRIM COVER. SERVICE OF THIS COMPONENT SHOULD BE PERFORMED ONLY BY CHRYSLER-TRAINED AND AUTHORIZED DEALER SERVICE TECHNICIANS. FAILURE TO TAKE THE PROPER PRECAUTIONS OR TO FOLLOW THE PROPER PROCEDURES COULD RESULT IN ACCIDENTAL, INCOMPLETE, OR IMPROPER AIRBAG DEPLOYMENT AND POSSIBLE PERSONAL INJURY. REFER TO DRIVER SIDE AIRBAG TRIM COVER AND HORN SWITCH IN GROUP 8M - PASSIVE RESTRAINT SYSTEMS FOR THE SERVICE PROCEDURES.

HORN

- (1) Disconnect and isolate the battery negative cable.
- (2) Raise and support the vehicle.
- (3) Remove the radiator lower air deflector. Refer to Group 7 - Cooling System for the procedures.
- (4) Unplug the wire harness connectors from the horns (Fig. 3).
- (5) Remove the screw that secures the horn mounting bracket to the radiator closure extension panel.

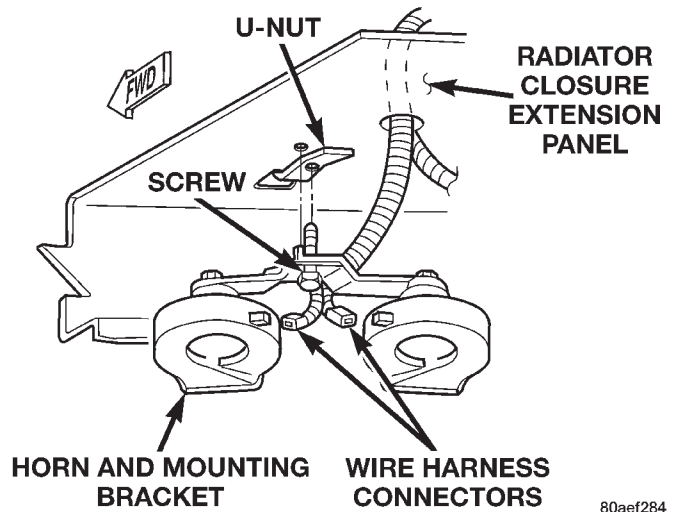


Fig. 3 Horns Remove/Install

- (6) Remove the horns and mounting bracket from the vehicle.
- (7) Reverse the removal procedures to install. Tighten the horn mounting bracket screw to 28 N·m (250 in. lbs.).

80aef284

SPEED CONTROL SYSTEM

CONTENTS

	page		page
GENERAL INFORMATION		SPEED CONTROL SET	4
INTRODUCTION	1	ROAD TEST	2
DESCRIPTION AND OPERATION		SPEED CONTROL SERVO	3
POWERTRAIN CONTROL MODULE	2	SPEED CONTROL SWITCHES	3
SERVO CABLE	2	STOP LAMP SWITCH	3
SPEED CONTROL SERVO	1	VACUUM SUPPLY TEST	3
SPEED CONTROL SOLENOID CIRCUITS	1	VEHICLE SPEED SENSOR	3
SPEED CONTROL SWITCHES	1	REMOVAL AND INSTALLATION	
STOP LAMP SWITCH	2	SERVO CABLE	6
VACUUM RESERVOIR	2	SPEED CONTROL SERVO	4
VEHICLE SPEED SENSOR	2	SPEED CONTROL SWITCHES	5
DIAGNOSIS AND TESTING		STOP LAMP SWITCH	6
ON-BOARD DIAGNOSTIC TEST FOR		VACUUM RESERVOIR	6
SPEED CONTROL SYSTEM	2	SPECIFICATIONS	
OVERSHOOT/UNDERSHOOT FOLLOWING		TORQUE CHART	7

GENERAL INFORMATION

INTRODUCTION

The vehicle speed control system is electronically controlled and vacuum operated. The system is designed to operate between approximately 35 and 85 mph (56 and 137 km/h). Following are general descriptions of the major components in the speed control system. For diagnosis of the entire speed control system, refer to the appropriate Powertrain Diagnostic Procedures service manual and the DRB scan tool. Refer to Group 8W, Wiring Diagrams for complete circuit descriptions and wiring diagrams.

DESCRIPTION AND OPERATION

SPEED CONTROL SERVO

The servo unit consists of a solenoid valve body, a vacuum servo and the mounting bracket. The Powertrain Control Module (PCM) controls the solenoid valve body. The solenoid valve body controls the application and release of vacuum to the diaphragm of the vacuum servo. A cable connects the servo with the throttle linkage. The servo unit cannot be repaired and is serviced only as a complete assembly.

SPEED CONTROL SOLENOID CIRCUITS

When all of the speed control parameters are met, and the SET button is pressed, the PCM actuates the

vent solenoid and “duty-cycles” the vacuum solenoid to open the throttle and bring the vehicle up to target speed. When the vehicle is at target speed, it will actuate the vent solenoid with the vacuum solenoid de-activated to maintain the vehicle at target speed. When the vehicle is above target speed, the PCM will “duty-cycle” the vent solenoid with the vacuum solenoid still de-activated to close the throttle to return to target speed.

SPEED CONTROL SWITCHES

Two separate speed control switch modules are mounted on the steering wheel to the left and right side of the driver’s airbag module. Within the two switch modules, five **momentary** contact switches, supporting seven different speed control functions are used. The outputs from these switches are filtered into one input. The Powertrain Control Module (PCM) determines which output has been applied through **resistive multiplexing**. The input circuit voltage is measured by the PCM to determine which switch function has been selected.

A speed control indicator lamp, located on the instrument panel cluster is energized by the PCM via the CCD Bus. This occurs when speed control system power has been turned ON, and the engine is running.

The two switch modules are labeled: ON/OFF, SET, RESUME/ACCEL, CANCEL and COAST. Refer to the owner’s manual for more information on speed

DESCRIPTION AND OPERATION (Continued)

control switch functions and setting procedures. The individual switches cannot be repaired. If one individual switch fails, the switch module must be replaced.

STOP LAMP SWITCH

Vehicles equipped with the speed control option use a dual function stop lamp switch. The switch is mounted in the same location as the conventional stop lamp switch, on the brake pedal mounting bracket under the instrument panel. The PCM monitors the state of the dual function stop lamp switch. Refer to Group 5, Brakes for more information on stop lamp switch service and adjustment procedures.

SERVO CABLE

The speed control servo cable is connected between the speed control vacuum servo diaphragm and the throttle body control linkage. This cable causes the throttle control linkage to open or close the throttle valve in response to movement of the vacuum servo diaphragm.

POWERTRAIN CONTROL MODULE

The speed control electronic control circuitry is integrated into the Powertrain Control Module (PCM). The PCM is located in the engine compartment. The PCM speed control functions are monitored by the On-Board Diagnostics (OBD). All OBD-sensed systems are monitored by the PCM. Each monitored circuit is assigned a Diagnostic Trouble Code (DTC). The PCM will store a DTC in electronic memory for certain failures it detects. See On-Board Diagnostic Test For Speed Control System in this group for more information. The PCM cannot be repaired and must be replaced if faulty.

VACUUM RESERVOIR

A vacuum reservoir is used to supply the vacuum needed to maintain proper speed control operation when engine vacuum drops, such as in climbing a grade while driving. A one-way check valve is used in the vacuum line between the reservoir and the vacuum source. This check valve is used to trap engine vacuum in the reservoir. On certain vehicle applications, this reservoir is shared with the heating/air-conditioning system. The vacuum reservoir cannot be repaired and must be replaced if faulty.

VEHICLE SPEED SENSOR

The Vehicle Speed Sensor (VSS) is a pulse generator mounted to an adapter near the transmission output shaft. The sensor is driven through the adapter by a speedometer pinion gear. The VSS pulse signal to the speedometer/odometer is monitored by the

PCM speed control circuitry to determine vehicle speed and to maintain speed control set speed.

DIAGNOSIS AND TESTING

ROAD TEST

Perform a vehicle road test to verify reports of speed control system malfunction. The road test should include attention to the speedometer. Speedometer operation should be smooth and without flutter at all speeds.

Flutter in the speedometer indicates a problem which might cause surging in the speed control system. The cause of any speedometer problems should be corrected before proceeding. Refer to Group 8E, Instrument Panel and Gauges for speedometer diagnosis.

If a road test verifies a system problem and the speedometer operates properly, check for:

- A Diagnostic Trouble Code (DTC). If a DTC exists, conduct tests per the Powertrain Diagnostic Procedures service manual.
- A misadjusted brake (stop) lamp switch. This could also cause an intermittent problem.
- Loose, damaged or corroded electrical connections at the servo. Corrosion should be removed from electrical terminals and a light coating of Mopar MultiPurpose Grease, or equivalent, applied.
- Leaking vacuum reservoir.
- Loose or leaking vacuum hoses or connections.
- Defective one-way vacuum check valve.
- Secure attachment of both ends of the speed control servo cable.
- Smooth operation of throttle linkage and throttle body air valve.
- Failed speed control servo. Do the servo vacuum test.

CAUTION: When test probing for voltage or continuity at electrical connectors, care must be taken not to damage connector, terminals or seals. If these components are damaged, intermittent or complete system failure may occur.

ON-BOARD DIAGNOSTIC TEST FOR SPEED CONTROL SYSTEM

The Powertrain Control Module (PCM) monitors critical input and output circuits of the speed control system, making sure they are operational. A Diagnostic Trouble Code (DTC) is assigned to each input and output circuit monitored by the On-Board Diagnostic (OBD) system. Some circuits are checked continuously and some are checked only under certain conditions.

DIAGNOSIS AND TESTING (Continued)

For DTC information, refer to Diagnostic Trouble Codes in Group 25, Emission Control System. This will include a complete list of DTC's including DTC's for the speed control system.

VEHICLE SPEED SENSOR

For diagnosis and testing of the Vehicle Speed Sensor (VSS), refer to the appropriate Powertrain Diagnostic Procedures service manual. Also refer to the DRB scan tool.

SPEED CONTROL SWITCHES

For complete speed control system diagnosis, refer to the appropriate Powertrain Diagnostic Procedures manual. To test each of the speed control switches only, refer to the following:

WARNING: BEFORE ATTEMPTING TO DIAGNOSE, REMOVE OR INSTALL ANY AIRBAG SYSTEM OR RELATED STEERING WHEEL AND STEERING COLUMN COMPONENTS, YOU MUST FIRST DISCONNECT AND ISOLATE THE BATTERY NEGATIVE (GROUND) CABLE. WAIT 2 MINUTES FOR SYSTEM CAPACITOR TO DISCHARGE BEFORE FURTHER SYSTEM SERVICE. FAILURE TO DO SO COULD RESULT IN ACCIDENTAL AIRBAG DEPLOYMENT AND POSSIBLE PERSONAL INJURY.

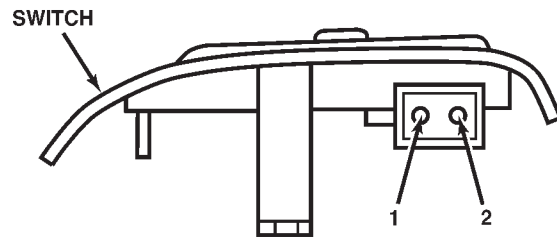
- (1) Disconnect negative battery cable. Wait 2 minutes for airbag system capacitor to discharge.
- (2) Remove the two speed control switch modules from steering wheel. Refer to the removal/installation section for procedures.
- (3) Check continuity of each individual speed control switch module as shown in chart (Fig. 1). If OK, reinstall switch. If not OK, replace switch module assembly.

STOP LAMP SWITCH

For continuity checks and switch adjustment, refer to Group 5, Brakes.

VACUUM SUPPLY TEST

- (1) Disconnect vacuum hose at speed control servo and install a vacuum gauge into the disconnected hose.
- (2) Start engine and observe gauge at idle. Vacuum gauge should read at least ten inches of mercury.
- (3) If vacuum is less than ten inches of mercury, determine source of leak. Check vacuum line to engine for leaks. Also check actual engine intake manifold vacuum. If manifold vacuum does not meet this requirement, check for poor engine performance and repair as necessary.
- (4) If vacuum line to engine is not leaking, check for leak at vacuum reservoir. To locate and gain



SWITCH POSITION	RESISTANCE BETWEEN PINS 1 AND 2
ON	909 ohms +/- 9 ohms
SET	6650 ohms +/- 66 ohms
RESUME/ACCEL	15,400 ohms +/- 154 ohms
CANCEL	0 ohms (CLOSED CIRCUIT)
COAST	2940 ohms +/- 29 ohms

80a53490

Fig. 1 Speed Control Switch Continuity

access to reservoir, refer to Vacuum Reservoir Removal/Installation in this group. Disconnect vacuum line at reservoir and connect a hand-operated vacuum pump to reservoir fitting. Apply vacuum. Reservoir vacuum should not bleed off. If vacuum is being lost, replace reservoir.

(5) Verify operation of one-way check valve and check it for leaks.

(a) Locate one-way check valve. The valve is located in vacuum line between vacuum reservoir and engine vacuum source. Disconnect vacuum hoses (lines) at each end of valve.

(b) Connect a hand-operated vacuum pump to reservoir end of check valve. Apply vacuum. Vacuum should not bleed off. If vacuum is being lost, replace one-way check valve.

(c) Connect a hand-operated vacuum pump to vacuum source end of check valve. Apply vacuum. Vacuum should flow through valve. If vacuum is not flowing, replace one-way check valve. Seal the fitting at opposite end of valve with a finger and apply vacuum. If vacuum will not hold, diaphragm within check valve has ruptured. Replace valve.

SPEED CONTROL SERVO

For complete speed control system diagnosis, refer to the appropriate Powertrain Diagnostic Procedures manual. To test the speed control servo only, refer to the following:

The engine must be started and running for the following voltage tests.

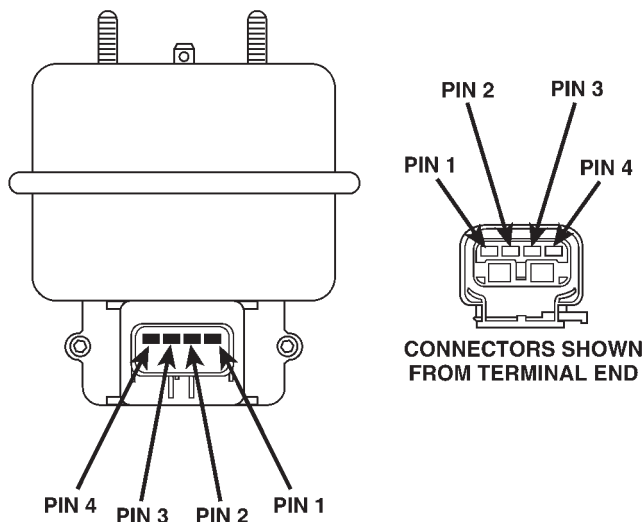
- (1) Start engine.
- (2) Disconnect 4-way electrical connector at servo.

DIAGNOSIS AND TESTING (Continued)

(3) Turn speed control switch to ON position.

(4) Check for battery voltage at pin-3 of wiring harness 4-way connector (Fig. 2). This is the 12 volt feed from the stoplamp switch. When the brake pedal is depressed, voltage should not be present at pin-3. If voltage is not present with brake pedal **not** depressed, check for continuity between servo and stop lamp switch. Also check stop lamp switch adjustment. Refer to Group 5, Brakes for procedures.

(5) Connect a small gauge jumper wire between the disconnected servo harness 4-way connector pin-3, and pin-3 on the servo. Check for battery voltage at pins-1, 2 and 4 of the servo. If battery voltage is not at these pins, replace the servo.



80a5f268

Fig. 2 Servo 4-Way Harness Connector

(6) Turn ignition switch to OFF position. Check for continuity between disconnected servo harness 4-way connector pin-4 and a good ground. There should be continuity. If not OK, repair open circuit to ground as required.

OVERSHOOT/UNDERSHOOT FOLLOWING SPEED CONTROL SET

If the operator repeatedly presses and releases the set button with their foot off of the accelerator (a "lift foot set" to begin speed control operation), the vehicle may accelerate and exceed the desired set speed by up to 5 MPH (8 km/h) and then decelerate to less than the desired set speed before finally achieving the desired set speed.

The Speed Control has an adaptive strategy that compensates for vehicle-to-vehicle variations in speed control cable lengths. When the speed control is set with the vehicle operators foot off of the accelerator pedal, the speed control thinks there is excessive speed control cable slack and adapts. If the lift foot sets are continually used, the speed control overshoot/undershoot condition will develop.

To "unlearn" the overshoot/undershoot condition, the vehicle operator has to press and release the set button while maintaining the desired set speed with the accelerator pedal (not decelerating or accelerating), and then turn the cruise control switch to the OFF position (or press the CANCEL button if equipped) after waiting 10 seconds. This procedure must be performed approximately 10-15 times to completely unlearn the overshoot/undershoot condition.

REMOVAL AND INSTALLATION**SPEED CONTROL SERVO****REMOVAL**

- (1) Disconnect negative battery cable at battery.
- (2) Disconnect vacuum line at servo (Fig. 3).
- (3) Disconnect electrical connector at servo.
- (4) Disconnect servo cable at throttle body. Refer to Servo Cable Removal/Installation in this group.

REMOVAL AND INSTALLATION (Continued)

(5) Remove 2 mounting nuts holding servo cable sleeve to bracket (Fig. 3) or (Fig. 4).

(6) Pull speed control cable sleeve and servo away from servo mounting bracket to expose cable retaining clip (Fig. 4) and remove clip. Note: The servo mounting bracket displayed in (Fig. 4) is a typical bracket and may/may not be applicable to this model vehicle.

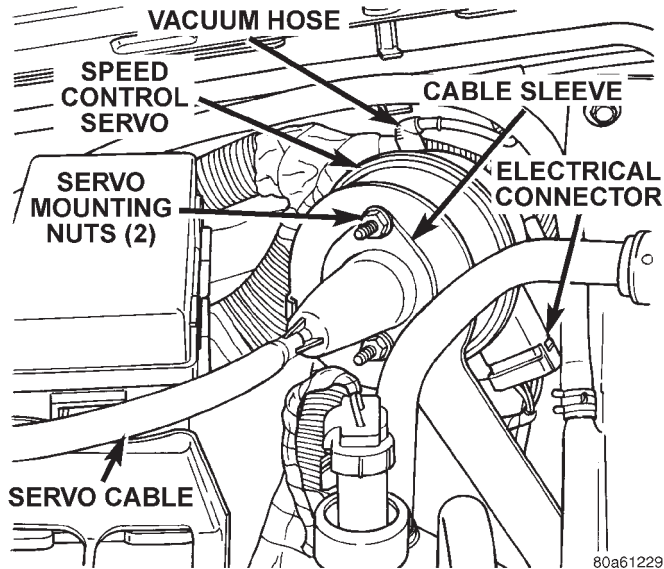


Fig. 3 Speed Control Servo Location

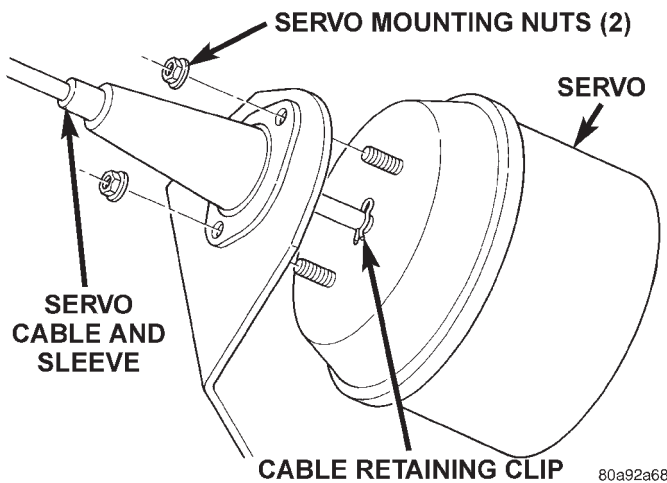


Fig. 4 Servo Cable Clip Remove/Install—Typical

(7) Remove servo from mounting bracket.

INSTALLATION

- (1) Position servo to mounting bracket.
- (2) Align hole in cable connector with hole in servo pin. Install cable-to-servo retaining clip.
- (3) Insert servo mounting studs through holes in servo mounting bracket.
- (4) Install servo mounting nuts and tighten to 8.5 N·m (75 in. lbs.).

- (5) Connect vacuum line at servo.
- (6) Connect electrical connector at servo.
- (7) Connect servo cable to throttle body. Refer to Servo Cable Removal/Installation in this group.
- (8) Connect negative battery cable to battery.
- (9) Before starting engine, operate accelerator pedal to check for any binding.

SPEED CONTROL SWITCHES

REMOVAL

WARNING: BEFORE BEGINNING ANY AIRBAG SYSTEM COMPONENT REMOVAL OR INSTALLATION, REMOVE AND ISOLATE THE NEGATIVE (-) CABLE FROM THE BATTERY. THIS IS THE ONLY SURE WAY TO DISABLE THE AIRBAG SYSTEM. THEN WAIT TWO MINUTES FOR SYSTEM CAPACITOR TO DISCHARGE BEFORE FURTHER SYSTEM SERVICE. FAILURE TO DO THIS COULD RESULT IN ACCIDENTAL AIRBAG DEPLOYMENT AND POSSIBLE INJURY.

- (1) Disconnect and isolate negative battery cable.
- (2) Remove airbag module. Refer to Group 8M, Passive Restraint Systems for procedures.
- (3) Remove electrical connector at switch.
- (4) Remove switch-to-steering wheel mounting screw (Fig. 5).
- (5) Remove switch.

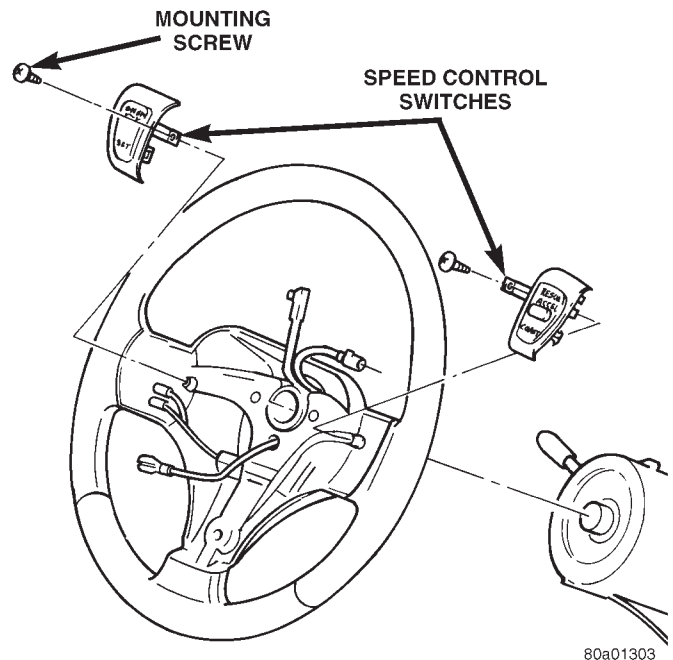


Fig. 5 Speed Control Switches

INSTALLATION

- (1) Install switch and mounting screw.
- (2) Tighten screw to 1.5 N·m (15 in. lbs.) torque.

REMOVAL AND INSTALLATION (Continued)

- (3) Install electrical connector to switch.
- (4) Install airbag module. Refer to Group 8M, Passive Restraint Systems for procedures.
- (5) Connect negative battery cable.

STOP LAMP SWITCH

Refer to Stop Lamp Switch in Group 5, Brakes for removal/installation and adjustment procedures.

SERVO CABLE**REMOVAL**

- (1) Disconnect negative battery cable at battery.
- (2) 4.0L Engine: Using finger pressure only, remove speed control cable connector at throttle body bellcrank pin by pushing connector off the bellcrank towards the drivers side of vehicle (Fig. 6). **DO NOT try to pull connector off perpendicular to the bellcrank pin. Connector will be broken.**

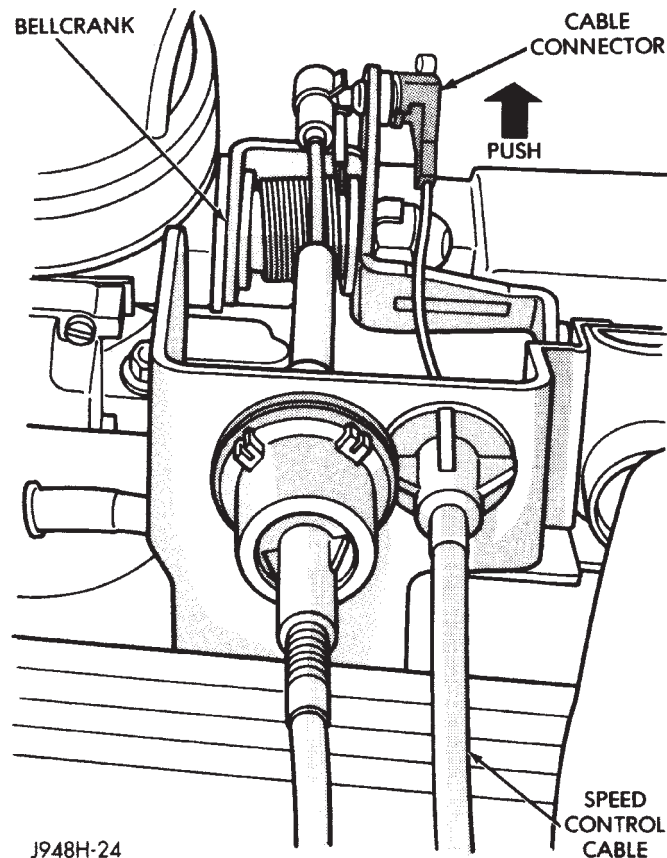


Fig. 6 Cable at Bell Crank—4.0L Engine

- (3) 5.2L/5.9L Engines: Using finger pressure only, remove speed control cable connector at throttle body bellcrank by pushing connector rearward off the bellcrank pin (Fig. 7). **DO NOT try to pull connector off perpendicular to the bellcrank pin. Connector will be broken.**

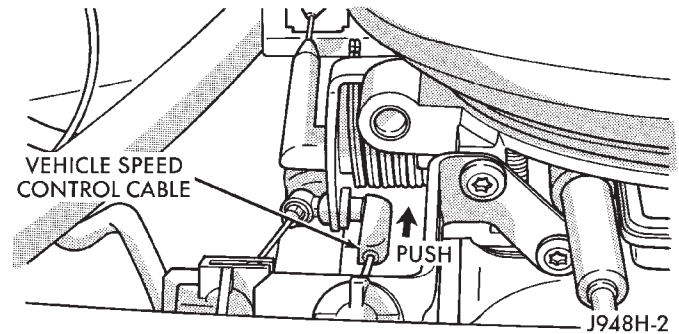


Fig. 7 Cable at Bell Crank—5.2L/5.9L V-8 Engines

- (4) 4.0L Engine: Remove cable from cable guide at top of valve cover.
- (5) Squeeze 2 tabs on sides of speed control cable at throttle body mounting bracket (locking plate) and push out of bracket.
- (6) Remove servo cable from servo. Refer to Speed Control Servo Removal/Installation in this group.

INSTALLATION

- (1) Install end of cable to speed control servo. Refer to Speed Control Servo removal and installation in this group.
- (2) Install cable into throttle body mounting bracket (snaps in).
- (3) Install speed control cable connector at throttle body bellcrank pin (snaps on).
- (4) Connect negative battery cable at battery.
- (5) Before starting engine, operate accelerator pedal to check for any binding.

VACUUM RESERVOIR

The vacuum reservoir is located under the vehicle battery tray.

REMOVAL

- (1) Disconnect both battery cables at battery (negative cable first).
- (2) Remove battery. Refer to Group 8A, Battery for procedure.

REMOVAL AND INSTALLATION (Continued)

- (3) Remove 5 bolts securing battery tray.
- (4) Pull up battery tray and remove vacuum hose from reservoir (Fig. 8).
- (5) Remove 2 screws holding reservoir to battery tray.

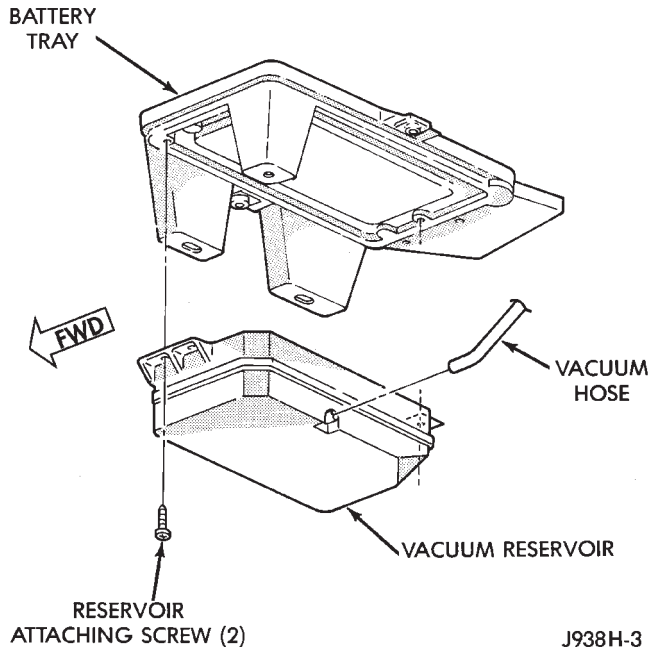


Fig. 8 Vacuum Reservoir Location

INSTALLATION

- (1) Install vacuum reservoir. Tighten bolts (screws) to 3 N·m (30 in. lbs.) torque.
- (2) Connect vacuum hose at reservoir.
- (3) Install battery tray mounting bolts. Tighten to 10 N·m (90 in. lbs.) torque.
- (4) Install battery.
- (5) Install battery holddown and bolts. Tighten to 10 N·m (90 in. lbs.) torque.
- (6) Install battery cable clamp bolts. Tighten to 8.5 N·m (75 in. lbs.) torque.

SPECIFICATIONS

TORQUE CHART

Description	Torque
Servo Mounting	
Bracket-to-Servo Nuts	8.5 N·m (75 in. lbs.)
Servo Mounting	
Bracket-to-Body Nuts5 N·m (47 in. lbs.)
Switch Module	
Mounting Screws	1.5 N·m (15 in. lbs.)
Vacuum Reservoir	
Mounting Bolts3 N·m (30 in. lbs.)

VEHICLE SPEED CONTROL SYSTEM

CONTENTS

page

GENERAL INFORMATION

INTRODUCTION 1

GENERAL INFORMATION

INTRODUCTION

This group covers both Left-Hand Drive (LHD) and Right-Hand Drive (RHD) versions of this model. Whenever feasible, the RHD versions of affected vehicle components have been constructed as mirror-image of the LHD versions. While most of the illustrations used in this group represent only the LHD version, the diagnostic and service procedures outlined can generally be applied to either version. Exceptions to this rule have been clearly identified as LHD or RHD, if a special illustration or procedure was/is required.

The speed control system used with the 2.5L diesel engine is basically identical to the system used with gasoline powered engines. Features unique to the diesel engine will be covered in this section.

- Models equipped with the 2.5L diesel engine do not use a vacuum reservoir to retain engine vacuum for speed control operation. There are no vacuum-operated speed control servos used in vehicles with the 2.5L diesel engine.
- The range of the speed control system operation is restricted to speeds between 56 km/h (35 MPH) to 145 km/h (90 MPH).
- Inputs to the MSA that allow speed control operation are from the vehicle speed sensor and the Speed Control Switch.

- Two separate speed control switch modules are mounted on the steering wheel to the left and right side of the driver's airbag module. Switch features are:

- a. Within the two switch modules, five **momentary** contact switches, supporting seven different speed control functions are used.
- b. The outputs from these switches are filtered into one input. The MSA determines which output has been applied through **resistive multiplexing**. The input circuit voltage is measured by the MSA to determine which switch function has been selected.
- c. A speed control indicator lamp, located on the instrument panel cluster is energized by the MSA via the CCD Bus. This occurs when speed control system power has been turned ON, and the engine is running.
- d. The two switch modules are labeled: ON/OFF, SET, RESUME/ACCEL, CANCEL and COAST. Refer to the owner's manual for more information on speed control switch functions and setting procedures. The individual switches cannot be repaired. If one individual switch fails, the switch module must be replaced.

TURN SIGNAL AND HAZARD WARNING SYSTEMS

CONTENTS

	page	page
GENERAL INFORMATION		
INTRODUCTION	1	
DESCRIPTION AND OPERATION		
COMBINATION FLASHER	1	
HAZARD WARNING SYSTEM	1	
TURN SIGNAL INDICATOR LAMP	3	
TURN SIGNAL LAMP	3	
TURN SIGNAL SWITCH AND HAZARD WARNING SWITCH	2	
TURN SIGNAL SYSTEM	1	
		3
DIAGNOSIS AND TESTING		
INTRODUCTION		3
MULTI-FUNCTION SWITCH		4
TURN SIGNAL AND HAZARD WARNING SYSTEMS		3
REMOVAL AND INSTALLATION		
COMBINATION FLASHER		5
MULTI-FUNCTION SWITCH		6

GENERAL INFORMATION

INTRODUCTION

Following are general descriptions of the major components in the turn signal and hazard warning systems. Refer to 8W-52 - Turn Signals in Group 8W - Wiring Diagrams for complete circuit descriptions and diagrams.

DESCRIPTION AND OPERATION

TURN SIGNAL SYSTEM

With the ignition switch in the On position, and the multi-function switch control lever moved up (right turn) or down (left turn), the turn signal system is activated. The switch has a detent position in each direction that provides turn signals with automatic cancellation, and an intermediate momentary position in each direction that provides turn signals only until the multi-function switch lever is released.

When the turn signal switch is in a detent position, it is turned off by one of two cancelling cam lobes molded into the hub of the clockspring mechanism. When turning the steering wheel causes one of the cam lobes to contact a cancel actuator in the multi-function switch, the turn signal switch automatically returns to the off position.

When the turn signal system is activated, the selected (right or left) turn signal indicator lamp, front park/turn signal lamp, front side marker lamp, and rear tail/stop/turn signal lamp bulbs will flash. With the headlamp switch in the Off position, the front turn signal and front side marker lamps flash in unison. With the headlamp switch in the On position, the front turn signal and front side marker lamps flash alternately.

HAZARD WARNING SYSTEM

The hazard warning system is activated by a switch button in the multi-function switch. The button is located on the top of the steering column between the steering wheel and the instrument panel. The hazard warning switch button is identified with a double triangle.

The hazard warning system is connected to a non-switched battery feed so that the system remains functional, regardless of the ignition switch position. Push the switch button in to activate the hazard warning system, and push in on the button again to turn the system off.

When the hazard warning system is activated, the right and left turn signal indicators, front park/turn signal lamps, front side marker lamps, and rear tail/stop/turn signal lamps will flash.

COMBINATION FLASHER

The combination flasher is a smart relay that functions as both the turn signal system and hazard warning system flasher. The combination flasher contains active electronic Integrated Circuitry (IC) elements. This flasher is designed to handle the current flow requirements of the factory-installed lighting. If supplemental lighting is added to the turn signal lamp circuits, such as when towing a trailer with lights, the combination flasher will automatically try to compensate to keep the flash rate the same.

While the combination flasher has a International Standards Organization (ISO)-type relay terminal configuration or footprint, the internal circuitry is much different. The combination flasher does not use standard ISO-relay inputs or provide ISO-relay type outputs or functions. The combination flasher should never be substituted for an ISO-relay or replaced

DESCRIPTION AND OPERATION (Continued)

with an ISO-relay, or else component and vehicle damage may occur.

The combination flasher has five blade-type terminals intended for the following inputs and outputs: Battery B+, Ignition B+, Ground, Turn Signal circuit, and Hazard Warning circuit. Constant battery voltage and ground are supplied to the flasher so that it can perform the hazard warning function, and ignition switched battery voltage is supplied for the turn signal function. Refer to 8W-52 - Turn Signals in Group 8W - Wiring Diagrams for complete circuit descriptions, diagrams and terminal function identification.

The IC within the combination flasher (Fig. 1) contains the logic that controls the flasher operation and the flash rate. Pin 6 of the IC receives a sense voltage from the hazard warning portion of the multi-function switch. When the hazard switch is turned on, the "hazard on sense" voltage will become low due to the circuit being grounded through the turn signal bulbs. This low voltage sense signals the IC to energize the flash control Positive-Negative-Positive (PNP) transistor at a pre-calibrated flash rate or frequency. Each time the PNP transistor energizes the hazard warning circuit, the pin 6 "hazard on sense" voltage will become high and the IC signals the PNP transistor to de-energize the circuit. This cycling will continue until the hazard warning switch is turned off.

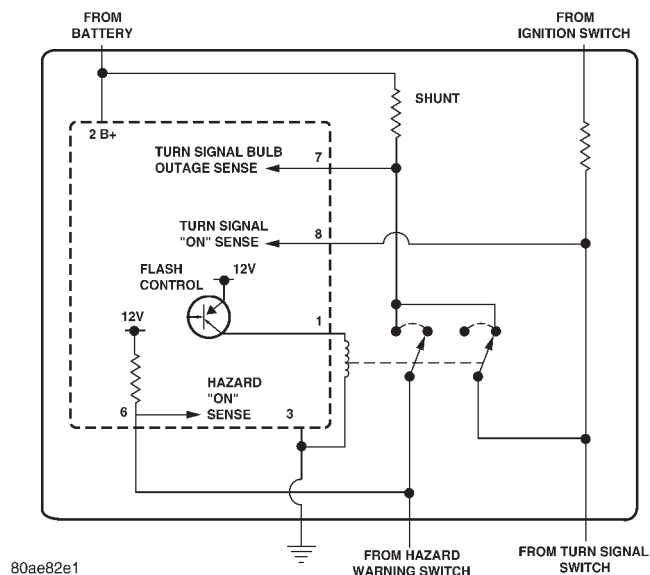


Fig. 1 Combination Flasher - Typical

Likewise, pin 8 of the IC receives a sense voltage from the turn signal portion of the multi-function switch. When the left or right turn signal is turned on, the "turn signal on sense" voltage will become low due to the circuit being grounded through the turn signal bulbs. This low voltage sense signals the IC to energize the flash control PNP transistor at a pre-

calibrated flash rate or frequency. Each time the PNP transistor energizes the turn signal circuit, the pin 8 "turn signal on sense" voltage will become high and the IC signals the PNP transistor to de-energize the circuit. This cycling will continue until the right or left turn signal is turned off.

A special design feature of the combination flasher allows it to "sense" that a turn signal circuit or bulb is not operating, and provide the driver an indication of the condition by flashing the remaining bulbs in the affected circuit at a higher rate (120 flashes-per-minute or higher). Conventional flashers either continue flashing at their typical rate (heavy-duty type), or discontinue flashing the affected circuit entirely (standard-duty type). During turn signal operation, the combination flasher IC compares normal battery voltage input on pin 2 with the shunt resistor voltage input on pin 7. If the IC "senses" that the voltage difference between pin 2 and pin 7 is different than the pre-calibrated value of the IC, it will increase the rate at which it signals the PNP transistor to energize the pin 1 output. Thus, the inoperative half (left or right side) of the turn signal circuit will flash faster.

Because of the active electronic elements within the combination flasher, it cannot be tested with conventional automotive electrical test equipment. If the combination flasher is believed to be faulty, test the turn signal and hazard warning system circuits as described in this group. Then replace the combination flasher with a known good unit to confirm system operation.

The combination flasher cannot be repaired and, if faulty or damaged, it must be replaced.

TURN SIGNAL SWITCH AND HAZARD WARNING SWITCH

The turn signal and hazard warning switches are integral to the multi-function switch assembly. The multi-function switch assembly is mounted to the left side of the steering column (Fig. 2). This switch contains circuitry for the following functions:

- Turn signals
- Hazard warning
- Headlamp beam selection
- Headlamp optical horn
- Windshield wipers
- Windshield washers.

The information contained in this group addresses only the multi-function switch functions for the turn signal and hazard warning circuits. For information relative to the other switch functions, refer to the proper group. However, the multi-function switch cannot be repaired. If any function of the multi-function switch is faulty, or if the switch is damaged, the entire switch assembly must be replaced.

DESCRIPTION AND OPERATION (Continued)

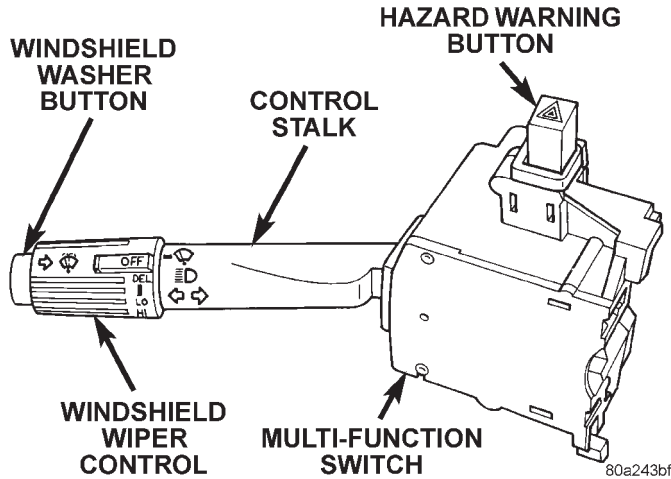


Fig. 2 Multi-Function Switch

TURN SIGNAL INDICATOR LAMP

The turn signal indicator lamps are located in the instrument cluster. They flash with the exterior turn signal lamps to give the driver a visual indication that a turn signal or the hazard warning system is operating. For diagnosis and service of these lamps, refer to Group 8E - Instrument Panel Systems.

VEHICLE INFORMATION CENTER

Models equipped with the optional Vehicle Information Center (VIC) have a "turn signal on" warning feature. The VIC module monitors the turn signal circuit through the combination flasher. The VIC module will display a Turn Signal On message and send a request to the Body Control Module (BCM) on the Chrysler Collision Detection (CCD) data bus network for six chime tones, if a turn signal remains activated for more than approximately one-half mile of driving.

Refer to Group 8E - Instrument Panel Systems for more information on the VIC module. For diagnosis of the VIC, the BCM or the CCD data bus, the use of a DRB scan tool and the proper Diagnostic Procedures manual are recommended.

TURN SIGNAL LAMP

The exterior lamps in the turn signal and hazard warning circuits include the front park/turn signal, the front side marker, and the rear tail/stop/turn signal. For diagnosis and service of these lamps, refer to Group 8L - Lamps.

DIAGNOSIS AND TESTING

INTRODUCTION

When diagnosing the turn signal or hazard warning circuits, remember that high generator output can burn out bulbs rapidly and repeatedly. If this is a problem on the vehicle being diagnosed, refer to Group 8C - Charging System for further diagnosis of a possible generator overcharging condition.

WARNING: ON VEHICLES EQUIPPED WITH AIRBAGS, REFER TO GROUP 8M - PASSIVE RESTRAINT SYSTEMS BEFORE ATTEMPTING ANY STEERING WHEEL, STEERING COLUMN, OR INSTRUMENT PANEL COMPONENT DIAGNOSIS OR SERVICE. FAILURE TO TAKE THE PROPER PRECAUTIONS COULD RESULT IN ACCIDENTAL AIRBAG DEPLOYMENT AND POSSIBLE PERSONAL INJURY.

TURN SIGNAL AND HAZARD WARNING SYSTEMS

For circuit descriptions and diagrams, refer to 8W-52 - Turn Signals in Group 8W - Wiring Diagrams.

WARNING: ON VEHICLES EQUIPPED WITH AIRBAGS, REFER TO GROUP 8M - PASSIVE RESTRAINT SYSTEMS BEFORE ATTEMPTING ANY STEERING WHEEL, STEERING COLUMN, OR INSTRUMENT PANEL COMPONENT DIAGNOSIS OR SERVICE. FAILURE TO TAKE THE PROPER PRECAUTIONS COULD RESULT IN ACCIDENTAL AIRBAG DEPLOYMENT AND POSSIBLE PERSONAL INJURY.

(1) Turn the ignition switch to the On position. Actuate the turn signal lever or the hazard warning button. Observe the turn signal indicator lamp(s) in the instrument cluster. If the flash rate is very high, check for a turn signal bulb that is not lit or is very dimly lit. Repair the circuits to that lamp or replace the faulty bulb, as required. Test the operation of the turn signal and hazard warning systems again. If the turn signal indicator(s) fail to light, go to Step 2.

(2) Turn the ignition switch to the Off position. Check the turn signal fuse in the junction block and/or the hazard warning fuse in the Power Distribution Center (PDC). If OK, go to Step 3. If not OK, repair the shorted circuit or component as required and replace the faulty fuse(s).

DIAGNOSIS AND TESTING (Continued)

(3) Turn the ignition switch to the On position to check for battery voltage at the turn signal fuse in the junction block; or, leave the ignition switch in the Off position to check for battery voltage at the hazard warning fuse in the PDC. If OK, go to Step 4. If not OK, repair the open circuit as required.

(4) Turn the ignition switch to the Off position. Disconnect and isolate the battery negative cable. Unplug the combination flasher from the junction block and replace it with a known good unit. Connect the battery negative cable. Test the operation of the turn signal and hazard warning systems. If OK, discard the faulty combination flasher. If not OK, remove the test flasher and go to Step 5.

(5) Turn the ignition switch to the On position. Check for battery voltage at the fused ignition switch output circuit cavity for the combination flasher in the junction block. If OK, go to Step 6. If not OK, repair the open circuit to the turn signal fuse as required.

(6) Turn the ignition switch to the Off position. Check for battery voltage at the fused B(+) circuit cavity for the combination flasher in the junction block. If OK, go to Step 7. If not OK, repair the open circuit to the hazard warning fuse as required.

(7) Disconnect and isolate the battery negative cable. Check for continuity between the ground circuit cavity for the combination flasher in the junction block and a good ground. There should be continuity. If OK, go to Step 8. If not OK, repair the circuit to ground as required.

(8) Unplug the multi-function switch wire harness connector as described in this group. Check for continuity between the combination flasher hazard signal circuit cavities in the junction block and in the multi-function switch wire harness connector. There

should be continuity. If OK, go to Step 9. If not OK, repair the open circuit as required.

(9) Check for continuity between the combination flasher turn signal circuit cavities in the junction block and in the multi-function switch wire harness connector. There should be continuity. If OK, test the multi-function switch as described in this group. If not OK, repair the open circuit as required.

MULTI-FUNCTION SWITCH

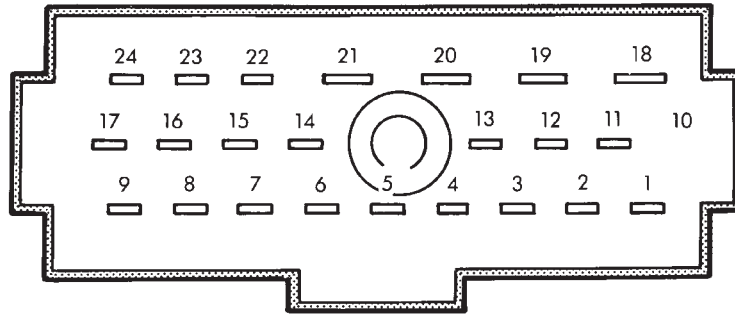
Perform the diagnosis of the hazard warning and/or turn signal systems as described in this group before testing the multi-function switch. For circuit descriptions and diagrams, refer to 8W-52 - Turn Signals in Group 8W - Wiring Diagrams.

WARNING: ON VEHICLES EQUIPPED WITH AIRBAGS, REFER TO GROUP 8M - PASSIVE RESTRAINT SYSTEMS BEFORE ATTEMPTING ANY STEERING WHEEL, STEERING COLUMN, OR INSTRUMENT PANEL COMPONENT DIAGNOSIS OR SERVICE. FAILURE TO TAKE THE PROPER PRECAUTIONS COULD RESULT IN ACCIDENTAL AIRBAG DEPLOYMENT AND POSSIBLE PERSONAL INJURY.

(1) Disconnect and isolate the battery negative cable. Unplug the multi-function switch wire harness connector.

(2) Using an ohmmeter, perform the switch continuity checks at the switch terminals as shown in the Multi-Function Switch Continuity chart (Fig. 3).

(3) If the switch fails any of the continuity checks, replace the faulty switch. If the switch is OK, repair the lighting circuits as required.



VIEW FROM TERMINAL CASE

SWITCH POSITIONS		CONTINUITY BETWEEN
TURN SIGNAL	HAZARD WARNING	
NEUTRAL	OFF	12 AND 14 AND 15
LEFT	OFF	15 AND 16 AND 17
LEFT	OFF	12 AND 14
LEFT	OFF	22 AND 23 WITH OPTIONAL CORNER LAMPS
RIGHT	OFF	11 AND 12 AND 17
RIGHT	OFF	14 AND 15
RIGHT	OFF	23 AND 24 WITH OPTIONAL CORNER LAMPS
NEUTRAL	ON	11 AND 12 AND 13 AND 15 AND 16

908J-4

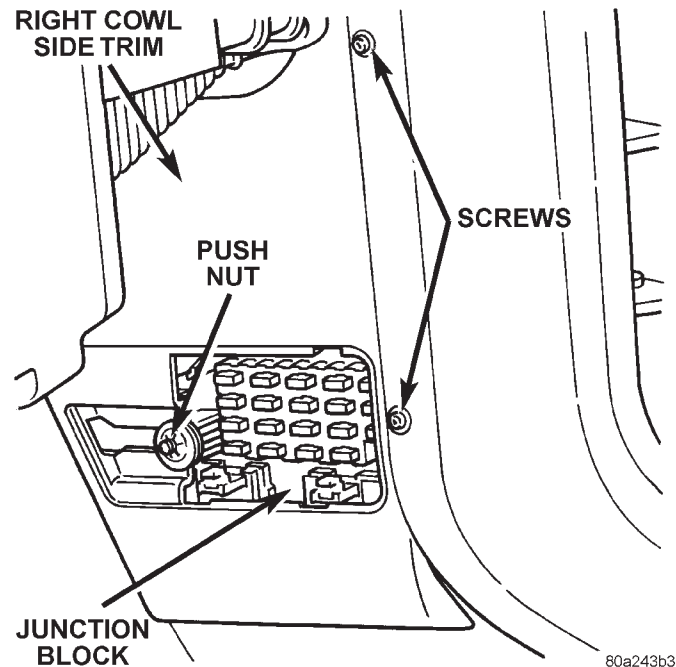
Fig. 3 Multi-Function Switch Continuity

REMOVAL AND INSTALLATION

COMBINATION FLASHER

WARNING: ON VEHICLES EQUIPPED WITH AIR-BAGS, REFER TO GROUP 8M - PASSIVE RESTRAINT SYSTEMS BEFORE ATTEMPTING ANY STEERING WHEEL, STEERING COLUMN, OR INSTRUMENT PANEL COMPONENT DIAGNOSIS OR SERVICE. FAILURE TO TAKE THE PROPER PRECAUTIONS COULD RESULT IN ACCIDENTAL AIR-BAG DEPLOYMENT AND POSSIBLE PERSONAL INJURY.

- (1) Disconnect and isolate the battery negative cable.
- (2) Remove the fuse access panel by unsnapping it from the right cowl side trim panel.
- (3) Remove the push nut that secures the right cowl side trim panel to the junction block stud (Fig. 4).
- (4) Remove the two screws that secure the right cowl side trim panel to the right front door opening trim.
- (5) Remove the right cowl side trim panel from the right cowl side inner panel.
- (6) Unplug the combination flasher from the junction block.



80a243b3

Fig. 4 Right Cowl Side Trim Panel Remove/Install

- (7) Install the combination flasher by aligning the flasher terminals with the cavities in the junction block and pushing the flasher firmly into place.
- (8) Connect the battery negative cable.
- (9) Test the flasher operation.

REMOVAL AND INSTALLATION (Continued)

(10) Reinstall the right cowl side trim panel and the fuse access panel.

MULTI-FUNCTION SWITCH

WARNING: ON VEHICLES EQUIPPED WITH AIR-BAGS, REFER TO GROUP 8M - PASSIVE RESTRAINT SYSTEMS BEFORE ATTEMPTING ANY STEERING WHEEL, STEERING COLUMN, OR INSTRUMENT PANEL COMPONENT DIAGNOSIS OR SERVICE. FAILURE TO TAKE THE PROPER PRECAUTIONS COULD RESULT IN ACCIDENTAL AIR-BAG DEPLOYMENT AND POSSIBLE PERSONAL INJURY.

(1) Disconnect and isolate the battery negative cable.

(2) If the vehicle is so equipped, remove the tilt steering column lever.

(3) Using a trim stick or another suitable wide flat-bladed tool, pry gently around the perimeter edges of both instrument panel switch pod bezels to release the snap clip retainers. Remove both bezels from the instrument panel.

(4) Remove the one screw on each side of the steering column that secures the upper edge of the steering column opening cover/knee blocker to the instrument panel (Fig. 5).

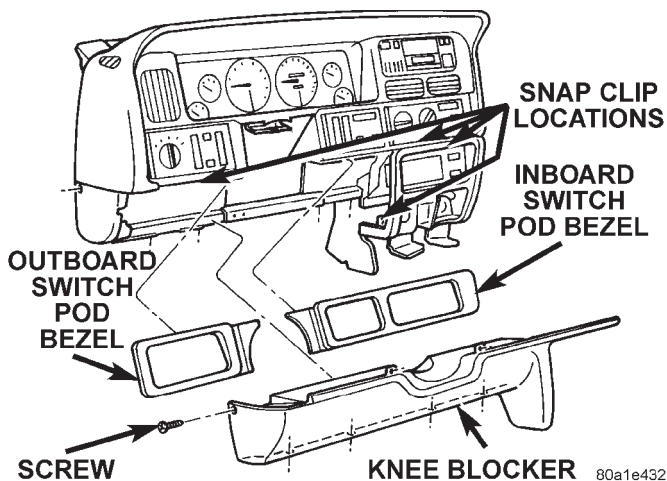


Fig. 5 Steering Column Opening Cover/Knee Blocker Remove/Install

(5) Remove the one screw that secures the steering column opening cover/knee blocker to the outboard end of the instrument panel.

(6) Remove the four screws that secure the lower edge of the steering column opening cover/knee blocker to the lower instrument panel reinforcement.

(7) Using a trim stick or another suitable wide flat-bladed tool, gently pry the edges of the steering column opening cover/knee blocker away from the

instrument panel at the snap clip retainer locations (Fig. 5).

(8) Remove the steering column opening cover/knee blocker from the instrument panel.

(9) Remove both the upper and lower shrouds from the steering column (Fig. 6).

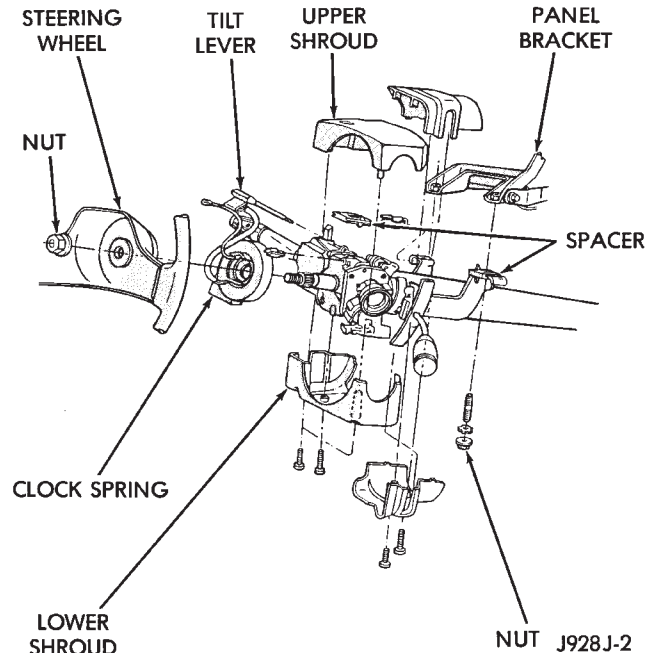


Fig. 6 Steering Column Shrouds Remove/Install - Typical

(10) Remove the lower fixed column shroud.

(11) Loosen the nuts that secure the steering column upper mounting bracket to the dash panel steering column support bracket studs. Lower the column far enough to move the upper fixed column shroud.

(12) Move the upper fixed column shroud far enough to access the rear of the multi-function switch (Fig. 7).

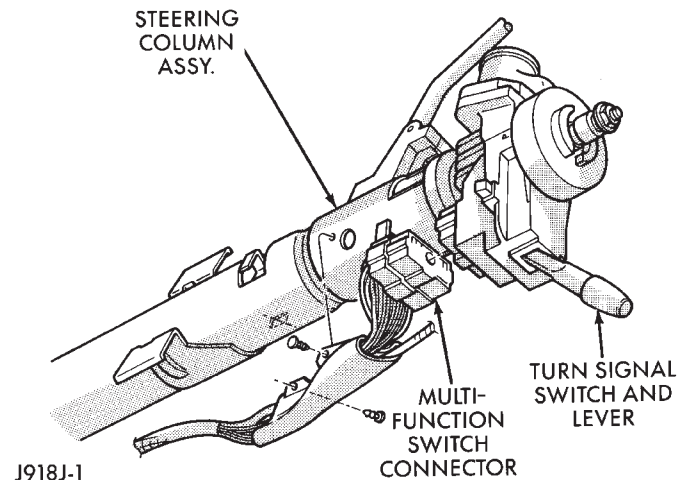


Fig. 7 Multi-Function Switch Connector - Typical

REMOVAL AND INSTALLATION (Continued)

(13) Remove the tamper proof mounting screws (a Snap On tamper proof torx bit TTXR20B2 or equivalent is required) that secure the multi-function switch to the steering column.

(14) Gently pull the switch away from the steering column far enough to access and loosen the multi-function switch wire harness connector screw. The screw will remain in the wire harness connector.

(15) Unplug the wire harness connector from the multi-function switch.

(16) Reverse the removal procedures to install. Tighten the fasteners as follows:

- Multi-function switch wire harness connector screw - 2 N·m (17 in. lbs.)
- Multi-function switch mounting screws - 2 N·m (17 in. lbs.)
- Steering column mounting nuts - 12 N·m (110 in. lbs.).

WIPER AND WASHER SYSTEMS

CONTENTS

	page		page
GENERAL INFORMATION		WIPER SWITCH AND WASHER SWITCH	3
INTRODUCTION	1	DIAGNOSIS AND TESTING	
DESCRIPTION AND OPERATION		INTERMITTENT WIPE RELAY	8
BODY CONTROL MODULE	3	WASHER SYSTEM	6
INTERMITTENT WIPE RELAY	4	WIPER SWITCH AND WASHER SWITCH	7
REAR WIPER AND WASHER SYSTEM	1	WIPER SYSTEM	5
WASHER FLUID LEVEL SENSOR	4	REMOVAL AND INSTALLATION	
WASHER NOZZLE AND PLUMBING	4	INTERMITTENT WIPE RELAY	12
WASHER PUMP	4	WASHER SYSTEM	14
WASHER RESERVOIR	4	WIPER ARM	10
WINDSHIELD WASHER SYSTEM	1	WIPER BLADE AND ELEMENT	9
WINDSHIELD WIPER SYSTEM	1	WIPER LINKAGE AND PIVOT	12
WIPER ARM AND BLADE	2	WIPER MOTOR	11
WIPER LINKAGE AND PIVOT	2	WIPER SWITCH AND WASHER SWITCH	13
WIPER MOTOR	2		

GENERAL INFORMATION

INTRODUCTION

Following are general descriptions of the major components in the wiper and washer systems. Refer to 8W-53 - Wipers in Group 8W - Wiring Diagrams for complete circuit descriptions and diagrams.

DESCRIPTION AND OPERATION

WINDSHIELD WIPER SYSTEM

An intermittent windshield wiper system is standard equipment. This system lets the driver select from either of two wiper speeds, or the intermittent wipe mode. The intermittent wipe mode is provided by delay logic and relay control circuitry contained within the Body Control Module (BCM), and an intermittent wipe relay.

The intermittent wipe mode delay times are speed sensitive. Above about sixteen kilometers-per-hour (ten miles-per-hour) the delay is driver adjustable from about one-half second to about eighteen seconds. Below about sixteen kilometers-per-hour (ten miles-per-hour) the BCM doubles the delay time, or provides delays of about one second to about thirty-six seconds.

Models equipped with the optional automatic headlamp system have a programmable feature in the BCM that will energize the headlamps automatically,

whenever the windshield wipers are turned on. Refer to the proper Diagnostic Procedures manual for more information on enabling or disabling this feature.

The windshield wipers will operate only when the ignition switch is in the Accessory or On positions. A circuit breaker located in the junction block protects the circuitry of the windshield wiper system. Refer to the owner's manual for more information on the windshield wiper system controls and operation.

WINDSHIELD WASHER SYSTEM

An electrically operated windshield washer system is standard equipment. A reservoir in the engine compartment holds the washer fluid, which is pressurized by a pump when the windshield washer (multi-function) switch button is actuated. The windshield washer pump feeds the pressurized washer fluid through the washer system plumbing to the windshield washer nozzles.

Vehicles with the optional Vehicle Information Center (VIC) have a low washer fluid warning feature that will warn the driver when the washer fluid level needs to be checked. Refer to Group 8E - Instrument Panel Systems for more information on this feature.

The washers will operate only when the ignition switch is in the Accessory or On positions. A circuit breaker located in the junction block protects the circuitry of the washer system. Refer to the owner's manual for more information on the windshield washer system controls and operation.

DESCRIPTION AND OPERATION (Continued)**REAR WIPER AND WASHER SYSTEM**

A rear wiper and washer system is standard equipment on this model. The rear wiper system provides the following operating modes:

- Intermittent wipe with a five to eight second delay between sweeps.
- Continuous fixed-cycle wipe.
- A park mode that operates the wiper motor until the blade reaches its park position when the rear wiper switch or ignition switch is placed in the Off position, or when the liftgate or liftglass (if the vehicle is so equipped) is opened.
- A rear washer mode that provides two or three wiper blade sweeps before returning to the previously selected rear wiper switch mode.

A single switch in the instrument panel inboard switch pod controls both the rear wiper and washer functions. The rear washer system shares the reservoir of the windshield washer system, but has its own dedicated washer pump and plumbing.

The rear wiper and washer systems will operate only when the ignition switch is in the Accessory or On positions, and when the liftgate and/or optional liftglass are closed. A fuse in the junction block protects the circuitry of both the rear wiper and washer systems.

The rear wiper motor circuitry monitors the liftgate ajar switch and optional liftglass ajar switch circuits. Refer to Group 8Q - Vehicle Theft/Security Systems for more information on the liftgate ajar and liftglass ajar switch circuits. Refer to the owner's manual for more information on the rear wiper and washer system controls and operation.

WIPER ARM AND BLADE

All Grand Cherokee models have two 50.8-centimeter (20-inch) windshield wiper blades with replaceable rubber elements (squeegees). The rear wiper uses a single 30.48-centimeter (12-inch) wiper blade with a non-replaceable rubber element (squeegee).

Caution should be exercised to protect the rubber squeegees from any petroleum-based cleaners or contaminants, which will rapidly deteriorate the rubber. If the squeegees are damaged, worn, or contaminated, the squeegees (front) or the entire wiper blade assembly (rear) must be replaced.

Wiper squeegees exposed to the elements for a long time tend to lose their wiping effectiveness. Periodic cleaning of the squeegees is suggested to remove deposits of salt and road film. The wiper blades, arms, and windshield or rear glass should be cleaned with a sponge or cloth and windshield washer fluid, a mild detergent, or a non-abrasive cleaner. If the squeegees continue to streak or smear, the squeegees (front) or wiper blade (rear) should be replaced.

The blades are mounted to spring-loaded wiper arms. The spring tension of the wiper arms controls the pressure applied to the blades on the glass. The windshield wiper arms are secured by an integral latch to the two wiper pivots on the cowl plenum cover/grille panel at the base of the windshield. The rear wiper arm is secured by a nut under the wiper arm pivot-end cover directly to the rear wiper motor output shaft on the liftgate panel.

The wiper arms and blades cannot be adjusted or repaired. If faulty or damaged, they must be replaced.

WIPER LINKAGE AND PIVOT

The wiper linkage and pivot module is secured with screws to the cowl plenum panel beneath the cowl plenum cover/grille panel. The wiper motor is secured with screws to the center of the linkage and pivot module bracket. The wiper pivots are secured to the ends of the module bracket.

The two wiper pivot crank arms and the wiper motor crank arm each have ball studs on their ends. The motor crank arm ball stud is the longer of the three. Two drive links connect the motor crank arm to the pivot crank arms.

The passenger side drive link has a plastic socket-type bushing on each end. The driver side drive link has a plastic socket-type bushing on one end, and a plastic sleeve-type bushing on the other end.

The socket-type bushing on one end of each drive link is snap-fit over the ball stud on the crank arm of its respective pivot. The driver side drive link sleeve-type bushing end is then fit over the motor crank arm ball stud, and the other socket-type bushing of the passenger side drive link is snap-fit over the exposed end of the motor crank arm ball stud.

The wiper linkage, pivots, bushings, motor crank arm and mounting bracket are only serviced as a complete unit. If any part of this assembly is faulty or damaged, the entire wiper linkage and pivots module must be replaced. The wiper motor is serviced separately.

WIPER MOTOR**FRONT**

The two-speed permanent magnet wiper motor has an integral transmission and park switch. The motor is secured to the wiper linkage and pivot module bracket with three screws. The wiper motor output shaft passes through a hole in the module bracket, where a nut secures the wiper motor crank arm to the motor output shaft.

Wiper speed is controlled by current flow to the proper set of brushes. The wiper motor completes its wipe cycle when the windshield wiper (multi-func-

DESCRIPTION AND OPERATION (Continued)

tion) switch is turned to the Off position, and parks the blades in the lowest portion of the wipe pattern.

The windshield wiper motor cannot be repaired. If faulty or damaged, the entire wiper motor assembly must be replaced. The wiper linkage and pivots module is also available for service.

REAR

The rear wiper motor is secured with two screws and nuts to a bracket on the passenger compartment side of the liftgate inner panel, below the rear glass and behind the liftgate trim panel. The motor output shaft passes through the liftgate outer panel where a gasket, bezel, and nut, seal and secure the unit to the liftgate outer panel. The rear wiper arm is secured directly to the motor output shaft with a nut.

The rear wiper motor unit contains integral electronic controls that provide the following operating modes:

- Intermittent wipe with a five to eight second delay between sweeps.
- Continuous fixed-cycle wipe.
- A park mode that operates the wiper motor until the blade reaches its park position when the rear wiper switch or ignition switch is placed in the Off position, or when the liftgate or liftglass (if the vehicle is so equipped) is opened.
- A rear washer mode that provides two or three wiper blade sweeps before returning to the previously selected rear wiper switch mode.

The rear wiper motor cannot be repaired. If faulty or damaged, the entire rear wiper motor assembly must be replaced.

WIPER SWITCH AND WASHER SWITCH**FRONT**

The windshield wiper and washer switches are contained in the multi-function switch assembly (Fig. 1). The multi-function switch assembly is secured to the left side of the steering column. A knob on the end of the multi-function switch stalk is rotated to select the desired wiper speed or intermittent wipe delay, or depressed toward the steering column to activate the washer system.

The multi-function switch contains circuitry for the following functions:

- Turn signals
- Hazard warning
- Headlamp beam selection
- Headlamp optical horn
- Windshield wipers
- Windshield washers.

The information contained in this group addresses only the switch functions for the windshield wiper and washer systems. For information relative to the other switch functions, refer to the proper group.

However, the multi-function switch cannot be repaired. If any function of the multi-function switch is faulty, or if the switch is damaged, the entire switch assembly must be replaced.

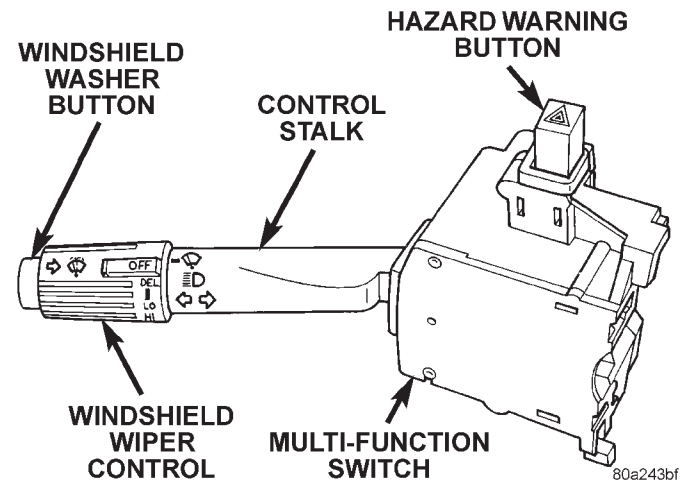


Fig. 1 Multi-Function Switch

REAR

The single two-function rear wiper and washer switch is part of the inboard switch pod unit, which is located on the instrument panel just inboard of the steering column. The rear wiper and washer switch controls the rear wiper and washer functions.

The sliding-type switch features a detent in the On and Delay positions. The switch knob is depressed to activate the rear washer system. Both the rear wiper and rear washer motors will operate continuously for as long as the switch is held in the momentary Wash position.

The rear wiper and washer switch cannot be repaired and, if faulty or damaged, the entire inboard switch pod unit must be replaced.

BODY CONTROL MODULE

A Body Control Module (BCM) is used on this model to control and integrate many of the electronic functions and features included on the vehicle. The BCM contains a central processing unit and interfaces with other modules in the vehicle on the Chrysler Collision Detection (CCD) data bus network.

The CCD data bus network allows the sharing of sensor information. This helps to reduce wire harness complexity, reduce internal controller hardware, and reduce component sensor current loads. At the same time, this system provides increased reliability, enhanced diagnostics, and allows the addition of many new feature capabilities.

Some of the functions and features that the BCM supports and controls are the speed sensitive intermittent wipe, pulse wipe, and wipe-after-wash modes. On models with the optional automatic head-

DESCRIPTION AND OPERATION (Continued)

lamps, the BCM can be programmed to automatically turn on the headlamps when the windshield wipers are turned on. Refer to the proper Diagnostic Procedures manual for more information on enabling or disabling this feature.

The BCM is programmed to energize or de-energize the intermittent wipe relay in response to certain inputs from the multi-function switch and the windshield wiper motor park switch. For the speed sensitive intermittent wipe feature, the BCM also uses an input from the vehicle speed sensor, which is received on the CCD data bus from the Powertrain Control Module (PCM).

The BCM is mounted under the driver side outboard end of the instrument panel, behind the instrument panel support armature and below the outboard switch pod. Refer to Group 8E - Instrument Panel Systems for the removal and installation procedures. For diagnosis of the BCM or the CCD data bus, the use of a DRB scan tool and the proper Diagnostic Procedures manual are recommended. The BCM can only be serviced by an authorized electronic repair station. Refer to the latest Warranty Policies and Procedures manual for a current listing of authorized electronic repair stations.

INTERMITTENT WIPE RELAY

The intermittent wipe relay is a International Standards Organization (ISO) micro-relay. The terminal designations and functions are the same as a conventional ISO relay. However, the micro-relay terminal orientation (or footprint) is different, current capacity is lower, and the relay case dimensions are smaller than those of the conventional ISO relay.

The intermittent wipe relay is a electromechanical device that switches battery current to the windshield wiper motor or wiper motor park switch when the relay coil is grounded by the Body Control Module (BCM) in response to inputs from the windshield wiper (multi-function) switch. See the Diagnosis and Testing section of this group for more information on the intermittent wipe relay.

The intermittent wipe relay is located in the Power Distribution Center (PDC), in the engine compartment. Refer to the PDC label for relay identification and location.

The intermittent wipe relay cannot be repaired and, if faulty or damaged, it must be replaced.

WASHER RESERVOIR

A single washer fluid reservoir is used for both the front and rear washer systems. The washer fluid reservoir is secured to the inner fender shield, behind the left front wheelhouse in the engine compartment.

Each washer pump and motor unit has a threaded nipple, which is installed through a rubber grommet

seal inserted in a hole near the bottom of the reservoir. A plastic nut and washer that secures the washer pump nipple from the inside of the reservoir, can be accessed through the reservoir filler neck.

The washer reservoir also has a provision for a washer fluid level sensor. The sensor mounts in a hole in the side of the reservoir that is nearest to the dash panel. Refer to Group 8E - Instrument Panel Systems for diagnosis of the sensor.

The washer reservoir, filler cap, and sensor are each available for service.

WASHER PUMP

The washer pumps and motors are mounted near the bottom of the washer reservoir. A threaded nipple on the pump housing passes through a rubber grommet seal installed in a hole near the bottom of the reservoir. A plastic nut and washer secures the washer pump nipple from the inside of the reservoir.

A permanently lubricated and sealed motor is coupled to a rotor-type pump. Washer fluid is gravity-fed from the reservoir to the pump. When the motor is energized, the pump pressurizes the washer fluid and forces it through the plumbing to the nozzles.

The washer pump and motor unit cannot be repaired. If faulty, the entire washer pump and motor unit must be replaced.

WASHER FLUID LEVEL SENSOR

The standard washer fluid level sensor is mounted on the back side of the washer reservoir. A barbed nipple on the sensor is press-fit into a rubber grommet seal installed in a hole in the back of the reservoir.

When the fluid level in the reservoir falls below the pivoting float on the sensor, the float changes position and closes the internal switch contacts of the sensor. Refer to Group 8E - Instrument Panel Systems for diagnosis of the low washer fluid warning lamp and circuit, including the sensor.

The washer fluid level sensor cannot be repaired. If faulty or damaged, the sensor unit must be replaced.

WASHER NOZZLE AND PLUMBING

FRONT

Pressurized washer fluid is fed through a single hose, attached to a barbed nipple on the front washer pump. The hose is routed to a tee fitting located in the cowl plenum area, beneath the cowl plenum cover/grille panel. Hoses from the tee fitting are routed to the two nozzles, which are snapped into openings in the cowl plenum cover/grille panel, below the windshield.

The two fluidic washer nozzles are not adjustable. The nozzles and hose fittings cannot be repaired and, if faulty or damaged, they must be replaced.

DESCRIPTION AND OPERATION (Continued)**REAR**

Pressurized washer fluid is fed through a single hose, attached to a barbed nipple on the rear washer pump. The hose is routed from the front of the vehicle to the liftgate with the left side body wire harness.

Above the liftgate opening the hose connects to a check valve, which prevents washer fluid drain-back or siphoning from occurring. From the check valve, another single hose is routed through grommets in holes in the upper liftgate opening panel and the liftgate inner panel to the washer nozzle. The washer nozzle snaps into a hole in the liftgate outer panel, above the liftgate glass.

The rear washer nozzle cannot be adjusted. The nozzle, check valve, and hose fittings cannot be repaired and, if faulty or damaged, they must be replaced.

DIAGNOSIS AND TESTING**WIPER SYSTEM****FRONT**

If the problem being diagnosed involves only the pulse wipe or wipe-after-wash modes, see the Washer System diagnosis in this group. For circuit descriptions and diagrams, refer to 8W-53 - Wipers in Group 8W - Wiring Diagrams.

WARNING: ON VEHICLES EQUIPPED WITH AIR-BAGS, REFER TO GROUP 8M - PASSIVE RESTRAINT SYSTEMS BEFORE ATTEMPTING ANY STEERING WHEEL, STEERING COLUMN, OR INSTRUMENT PANEL COMPONENT DIAGNOSIS OR SERVICE. FAILURE TO TAKE THE PROPER PRECAUTIONS COULD RESULT IN ACCIDENTAL AIR-BAG DEPLOYMENT AND POSSIBLE PERSONAL INJURY.

(1) Disconnect and isolate the battery negative cable. Remove the circuit breaker from the junction block. Connect the battery negative cable. Turn the ignition switch to the On position. Check for battery voltage at the battery side of the circuit breaker. If OK, reinstall the circuit breaker and go to Step 2. If not OK, repair the circuit from the ignition switch as required.

(2) Turn the ignition switch to the On position. Check for battery voltage at the wiper system side of the circuit breaker. If OK, go to Step 3. If not OK, replace the faulty circuit breaker.

(3) Turn the ignition switch to the Off position. Disconnect and isolate the battery negative cable. Unplug the multi-function switch wire harness connector. Connect the battery negative cable. Turn the

ignition switch to the On position. Check for battery voltage at the fused ignition switch output (F86) circuit cavity of the multi-function switch wire harness connector. If OK, go to Step 4. If not OK, repair the open circuit to the circuit breaker as required.

(4) If the problem being diagnosed involves only the intermittent wipe feature, go to Step 5. If the problem being diagnosed involves all wiper modes, or only the Low and/or High speed modes, go to Step 7.

(5) Turn the ignition switch to the Off position. Disconnect and isolate the battery negative cable. Unplug the white 24-way Body Control Module (BCM) wire harness connector. Check for continuity between the wiper switch mode sense cavities of the multi-function switch wire harness connector and the BCM white 24-way wire harness connector. There should be continuity. If OK, go to Step 6. If not OK, repair the open circuit as required.

(6) Unplug the black 24-way BCM wire harness connector. Check for continuity between the windshield wiper switch signal cavities of the multi-function switch wire harness connector and the BCM black 24-way wire harness connector. There should be continuity. If OK, see the Intermittent Wipe Relay diagnosis in this group. If not OK, repair the open circuit as required.

(7) Check for continuity between the two wiper switch low speed output circuit cavities of the multi-function switch wire harness connector. There should be continuity. If OK, go to Step 8. If not OK, repair the open circuit as required.

(8) Test the wiper switch, as described in this group. If the switch tests OK, plug in the multi-function switch wire harness connector and go to Step 9. If not OK, replace the faulty switch and test the wiper system operation. If still not OK, go to Step 9.

(9) Turn the ignition switch to the Off position. Disconnect and isolate the battery negative cable. Move the wiper module far enough to access the wiper motor wire harness connector, as described in this group. Measure the resistance between the ground circuit cavity of the wiper motor wire harness connector and a good ground. The meter should read zero ohms. If OK, go to Step 10. If not OK, repair the circuit to ground as required.

(10) Connect the battery negative cable. Turn the ignition switch to the On position. Place the multi-function switch in the positions indicated in the tests below, and check for battery voltage at the wiper motor wire harness connector.

(a) Check for battery voltage at the fused ignition switch output circuit cavity of the wiper motor wire harness connector with the wiper switch in any position. If OK, go to Step 2. If not OK, repair the open circuit as required.

DIAGNOSIS AND TESTING (Continued)

(b) Check for battery voltage at the wiper switch low speed output circuit cavity of the wiper motor wire harness connector with the wiper switch in the Low position. If OK, go to Step 3. If not OK, repair the open circuit as required.

(c) Check for battery voltage at the wiper switch high speed output circuit cavity of the wiper motor wire harness connector with the wiper switch in the High position. If OK, go to Step 4. If not OK, repair the open circuit as required.

(d) Check for battery voltage at the wiper park switch sense circuit cavity of the wiper motor wire harness connector with the wiper switch in the Low or High position, then move the switch to the Off position. The meter should switch between battery voltage and zero volts while the wipers are cycling. The meter should read battery voltage when the switch is moved to the Off position until the wipers park, and then read a steady zero volts. If not OK, replace the faulty wiper motor.

REAR

For circuit descriptions and diagrams, refer to 8W-53 - Wipers in Group 8W - Wiring Diagrams.

WARNING: ON VEHICLES EQUIPPED WITH AIRBAGS, REFER TO GROUP 8M - PASSIVE RESTRAINT SYSTEMS BEFORE ATTEMPTING ANY STEERING WHEEL, STEERING COLUMN, OR INSTRUMENT PANEL COMPONENT DIAGNOSIS OR SERVICE. FAILURE TO TAKE THE PROPER PRECAUTIONS COULD RESULT IN ACCIDENTAL AIRBAG DEPLOYMENT AND POSSIBLE PERSONAL INJURY.

(1) Check the fuse in the junction block. If OK, go to Step 2. If not OK, repair the shorted circuit or component as required and replace the faulty fuse.

(2) Turn the ignition switch to the On position. Check for battery voltage at the fused ignition switch output circuit cavity of the rear wiper switch wire harness connector. If OK, go to Step 3. If not OK, repair the open circuit as required.

(3) Turn the ignition switch to the Off position. Disconnect and isolate the battery negative cable. Remove and test the rear wiper switch, as described in this group. If OK, go to Step 4. If not OK, replace the faulty switch.

(4) Remove the liftgate inner trim panel. Measure the resistance between the ground circuit cavity of the rear wiper motor wire harness connector and a good ground. The meter should read zero ohms. If OK, go to Step 5. If not OK, repair the circuit to ground as required.

(5) Check for continuity between the liftgate ajar switch sense cavity of the rear wiper motor wire harness connector and a good ground. There should be

continuity with the liftgate and/or the liftglass (if the vehicle is so equipped) open, and no continuity with the liftgate and the liftglass closed. If OK, go to Step 6. If not OK, repair the liftgate and/or the liftglass ajar circuit or switch as required.

(6) Plug in the rear wiper switch wire harness connector. Connect the battery negative cable. Turn the ignition switch to the On position. Place the rear wiper switch in the Wipe position. Check for battery voltage at the rear wiper motor control circuit cavity of the rear wiper motor wire harness connector. Repeat the test for the rear wiper motor control (intermittent) circuit cavity with the rear wiper switch in the Intermittent position, then at the rear washer motor control circuit cavity with the rear wiper switch in the Wash position. In each case, the meter should read battery voltage. If OK, replace the faulty rear wiper motor. If not OK, repair the open circuit(s) as required.

WASHER SYSTEM**FRONT**

The diagnosis found here addresses an inoperative washer pump or wipe-after-wash feature. If the washer pump operates, but no washer fluid is emitted from the washer nozzles, be certain to check the fluid level in the reservoir. Check for ice or other foreign material in the reservoir, and for pinched, disconnected, broken, or incorrectly routed washer system plumbing. For circuit descriptions and diagrams, refer to 8W-53 - Wipers in Group 8W - Wiring Diagrams.

WARNING: ON VEHICLES EQUIPPED WITH AIRBAGS, REFER TO GROUP 8M - PASSIVE RESTRAINT SYSTEMS BEFORE ATTEMPTING ANY STEERING WHEEL, STEERING COLUMN, OR INSTRUMENT PANEL COMPONENT DIAGNOSIS OR SERVICE. FAILURE TO TAKE THE PROPER PRECAUTIONS COULD RESULT IN ACCIDENTAL AIRBAG DEPLOYMENT AND POSSIBLE PERSONAL INJURY.

(1) Turn the ignition switch to the On position. Turn the wiper switch to the Low or High speed position. Check whether the wipers operate. If OK, go to Step 2. If not OK, see the Wiper System diagnosis in this group.

(2) Turn the wiper switch to the Off position. Depress the washer switch for less than one-half second. The wipers should operate for one sweep cycle and then park. Depress the washer switch for more than one-half second. The washer pump should operate and the wipers should operate for two sweep cycles after the switch is released before they park. If the wipers are OK, but the washers are not, go to

DIAGNOSIS AND TESTING (Continued)

Step 3. If the washers are OK, but the wipers are not, go to Step 5.

(3) Turn the ignition switch to the Off position. Disconnect and isolate the battery negative cable. Unplug the front washer pump wire harness connector. Measure the resistance between the ground circuit cavity of the front washer pump wire harness connector and a good ground. The meter should read zero ohms. If OK, go to Step 4. If not OK, repair the ground circuit as required.

(4) Connect the battery negative cable. Turn the ignition switch to the On position. Depress the washer switch. Measure the voltage at the washer switch output circuit cavity of the front washer pump wire harness connector. The meter should read battery voltage. If OK, replace the faulty pump. If not OK, repair the open circuit as required.

(5) Turn the ignition switch to the Off position. Disconnect and isolate the battery negative cable. Unplug the white 24-way wire harness connector from the Body Control Module (BCM). Connect the battery negative cable. Turn the ignition switch to the On position. Depress the washer switch. Check for battery voltage at the washer switch output circuit cavity of the white 24-way BCM wire harness connector. If OK, see the Intermittent Wipe Relay diagnosis in this group. If not OK, repair the open circuit as required.

REAR

The diagnosis found here addresses an inoperative washer pump. If the washer pump operates, but no washer fluid is emitted from the washer nozzles, be certain to check the fluid level in the reservoir. Check for ice or other foreign material in the reservoir, and for pinched, disconnected, broken, or incorrectly routed washer system plumbing. For circuit descriptions and diagrams, refer to 8W-53 - Wipers in Group 8W - Wiring Diagrams.

WARNING: ON VEHICLES EQUIPPED WITH AIR-BAGS, REFER TO GROUP 8M - PASSIVE RESTRAINT SYSTEMS BEFORE ATTEMPTING ANY STEERING WHEEL, STEERING COLUMN, OR INSTRUMENT PANEL COMPONENT DIAGNOSIS OR SERVICE. FAILURE TO TAKE THE PROPER PRECAUTIONS COULD RESULT IN ACCIDENTAL AIR-BAG DEPLOYMENT AND POSSIBLE PERSONAL INJURY.

(1) Turn the ignition switch to the On position. Place the rear wiper/washer switch in the Wipe position. Check whether the rear wiper is operating. If OK, go to Step 2. If not OK, see the Wiper System diagnosis in this group.

(2) Turn the ignition switch to the Off position. Disconnect and isolate the battery negative cable.

Unplug the rear washer pump wire harness connector. Measure the resistance between the ground circuit cavity of the rear washer pump wire harness connector and a good ground. The meter should read zero ohms. If OK, go to Step 3. If not OK, repair the circuit to ground as required.

(3) Connect the battery negative cable. Turn the ignition switch to the On position. Depress the rear washer switch. Measure the voltage at the rear washer motor control circuit cavity of the rear washer pump wire harness connector. The meter should read battery voltage. If OK, replace the faulty pump. If not OK, repair the open circuit as required.

WIPER SWITCH AND WASHER SWITCH**FRONT**

Perform the diagnosis for the windshield wiper system and/or washer system as described in this group before testing the multi-function switch. For circuit descriptions and diagrams, see 8W-53 - Wipers in Group 8W - Wiring Diagrams.

WARNING: ON VEHICLES EQUIPPED WITH AIR-BAGS, REFER TO GROUP 8M - PASSIVE RESTRAINT SYSTEMS BEFORE ATTEMPTING ANY STEERING WHEEL, STEERING COLUMN, OR INSTRUMENT PANEL COMPONENT DIAGNOSIS OR SERVICE. FAILURE TO TAKE THE PROPER PRECAUTIONS COULD RESULT IN ACCIDENTAL AIR-BAG DEPLOYMENT AND POSSIBLE PERSONAL INJURY.

(1) Disconnect and isolate the battery negative cable.

(2) Unplug the multi-function switch wire harness connector from the multi-function switch.

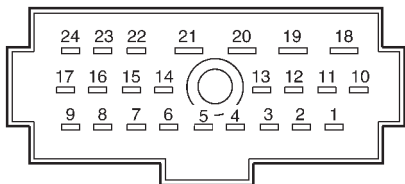
(3) Using an ohmmeter, perform the switch continuity checks at the switch terminals as shown in the Multi-Function Switch Continuity chart (Fig. 2).

(4) If the switch fails any of the continuity checks, replace the faulty switch. If the switch is OK, repair the wiper system and/or washer system wire harness circuits as required.

REAR

Perform the diagnosis for the rear wiper system and/or washer system as described in this group before testing the rear wiper and washer switch. For circuit descriptions and diagrams, see 8W-53 - Wipers in Group 8W - Wiring Diagrams.

DIAGNOSIS AND TESTING (Continued)



MULTIFUNCTION SWITCH PINS

SWITCH POSITION	CONTINUITY BETWEEN
OFF	PIN 6 AND PIN 7
DELAY	PIN 8 AND PIN 9 PIN 2 AND PIN 4 PIN 1 AND PIN 2 PIN 1 AND PIN 4
LOW	PIN 4 AND PIN 6
HIGH	PIN 4 AND PIN 5
WASH	PIN 3 AND PIN 4

*RESISTANCE AT MAXIMUM DELAY POSITION SHOULD BE BETWEEN 210,000 OHMS AND 390,000 OHMS.
*RESISTANCE AT MINIMUM DELAY POSITION SHOULD BE ZERO WITH OHMMETER SET ON HIGH OHM SCALE.

80a243cb

Fig. 2 Multi-Function Switch Continuity

WARNING: ON VEHICLES EQUIPPED WITH AIR-BAGS, REFER TO GROUP 8M - PASSIVE RESTRAINT SYSTEMS BEFORE ATTEMPTING ANY STEERING WHEEL, STEERING COLUMN, OR INSTRUMENT PANEL COMPONENT DIAGNOSIS OR SERVICE. FAILURE TO TAKE THE PROPER PRECAUTIONS COULD RESULT IN ACCIDENTAL AIR-BAG DEPLOYMENT AND POSSIBLE PERSONAL INJURY.

(1) Remove the rear wiper and washer switch from the instrument panel.

(2) Using an ohmmeter, check the rear wiper and washer switch continuity at the switch terminals as follows:

a. With the switch in the Off position, there should be no continuity between any two switch terminals.

b. With the switch knob depressed in the Wash position, there should be continuity between the fused ignition switch output circuit and the rear washer motor control circuit terminals.

c. With the switch in the Intermittent position, there should be continuity between the fused ignition switch output circuit and the rear wiper motor control (intermittent) circuit terminals.

d. With the switch in the On position, there should be continuity between the fused ignition switch output circuit and the rear wiper motor control circuit terminals.

(3) If the switch fails any of the continuity checks, replace the faulty switch. If the switch is OK, repair the rear wiper system and/or washer system wire harness circuits as required.

INTERMITTENT WIPE RELAY

For circuit descriptions and diagrams, refer to 8W-53 - Wipers in Group 8W - Wiring Diagrams.

WARNING: ON VEHICLES EQUIPPED WITH AIR-BAGS, REFER TO GROUP 8M - PASSIVE RESTRAINT SYSTEMS BEFORE ATTEMPTING ANY STEERING WHEEL, STEERING COLUMN, OR INSTRUMENT PANEL COMPONENT DIAGNOSIS OR SERVICE. FAILURE TO TAKE THE PROPER PRECAUTIONS COULD RESULT IN ACCIDENTAL AIR-BAG DEPLOYMENT AND POSSIBLE PERSONAL INJURY.

RELAY TEST

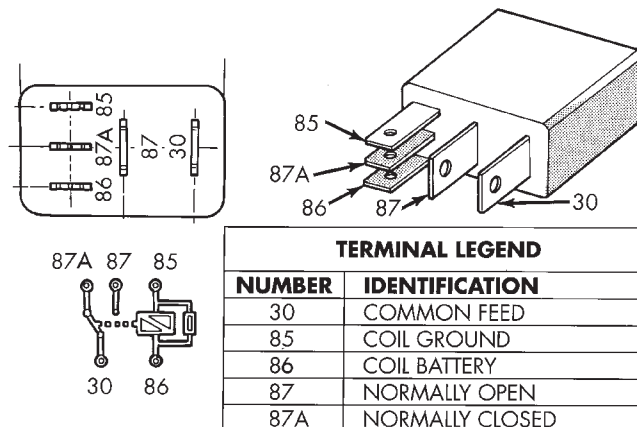
The intermittent wipe relay (Fig. 3) is located in the Power Distribution Center (PDC) in the engine compartment. Refer to the PDC label for intermittent wipe relay identification and location.

Remove the intermittent wipe relay from the PDC as described in this group to perform the following tests:

(1) A relay in the de-energized position should have continuity between terminals 87A and 30, and no continuity between terminals 87 and 30. If OK, go to Step 2. If not OK, replace the faulty relay.

(2) Resistance between terminals 85 and 86 (electromagnet) should be 75 ± 5 ohms. If OK, go to Step 3. If not OK, replace the faulty relay.

(3) Connect a battery to terminals 85 and 86. There should now be continuity between terminals 30 and 87, and no continuity between terminals 87A and 30. If OK, see the Relay Circuit Test in this group. If not OK, replace the faulty relay.



9514-16

Fig. 3 Intermittent Wipe Relay

RELAY CIRCUIT TEST

(1) The relay common feed terminal cavity (30) is connected to the wiper (multi-function) switch. There should be continuity between the cavity for relay ter-

DIAGNOSIS AND TESTING (Continued)

terminal 30 and the two fused ignition switch output (V6) circuit cavities of the multi-function switch connector at all times. If OK, go to Step 2. If not OK, repair the open circuit(s) to the multi-function switch as required.

(2) The relay normally closed terminal (87A) is connected to terminal 30 in the de-energized position. There should be continuity between the cavity for relay terminal 87A and the wiper park switch sense circuit cavities of the wiper motor wire harness connector and the white 24-way Body Control Module (BCM) wire harness connector at all times. If OK, go to Step 3. If not OK, repair the open circuit(s) to the wiper motor and BCM as required.

(3) The relay normally open terminal (87) is connected to the common feed terminal (30) in the energized position. There should be battery voltage at the cavity for relay terminal 87 with the ignition switch in the On or Accessory positions. If OK, go to Step 4. If not OK, repair the open circuit to the ignition switch as required.

(4) The coil battery terminal (86) is connected to the electromagnet in the relay. There should be battery voltage at the cavity for relay terminal 86 with the ignition switch in the On or Accessory positions. If OK, go to Step 5. If not OK, repair the open circuit to the ignition switch as required.

(5) The coil ground terminal (85) is connected to the electromagnet in the relay. It is grounded by the BCM to energize the relay and cycle the wiper motor. Check for continuity between the cavity for relay terminal 85 and the intermittent wiper relay control circuit cavity of the white 24-way BCM wire harness connector. There should be continuity. If OK, refer to the proper Diagnostic Procedures manual for diagnosis of the BCM. If not OK, repair the open circuit to the BCM as required.

REMOVAL AND INSTALLATION

WIPER BLADE AND ELEMENT

FRONT

NOTE: The pinch-release retainer end of the wiper element should always be oriented towards the end of the wiper blade that is nearest to the wiper pivot.

To remove the windshield wiper blade and/or element, proceed as follows:

(1) Turn the windshield wiper switch to the On position. By turning the ignition switch to the On and Off positions, cycle the wiper blades to a convenient working location on the windshield.

(2) Lift the wiper arm to raise the wiper blade and element off of the windshield glass.

(3) Remove the wiper blade from the wiper arm, or the wiper element from the wiper blade as follows:

(a) To remove the wiper blade from the wiper arm, push the release tab under the arm tip and slide the blade away from the tip towards the pivot end of the arm (Fig. 4).

(b) To remove the wiper element from the wiper blade, pinch the notched retainer (pivot) end of the wiper element tightly between the thumb and forefinger (Fig. 5). Then, pull the element firmly towards the wiper pivot to release the wiper blade claws from the wiper element retaining pockets. Once the claws are released from the retaining pockets, the element will slide easily out of the remaining claws.

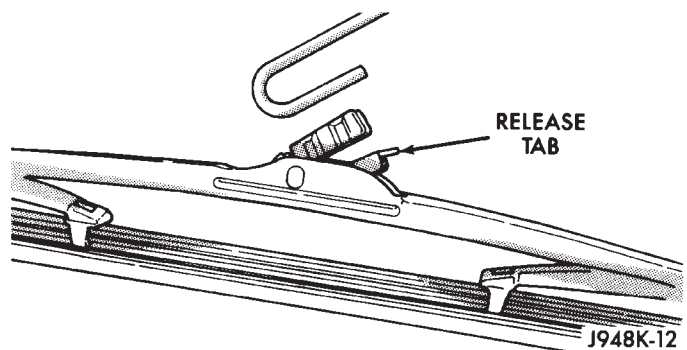


Fig. 4 Wiper Blade Remove/Install - Typical

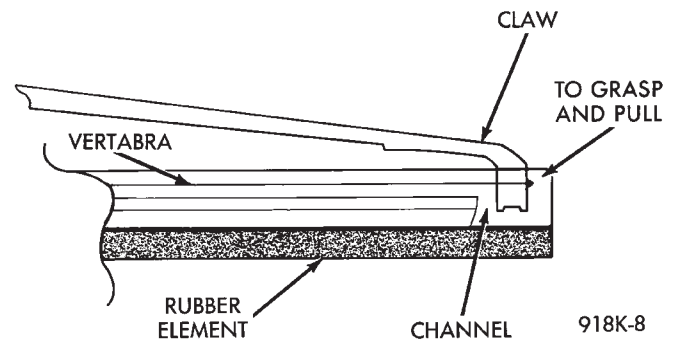


Fig. 5 Wiper Element Remove

(4) Install the wiper blade on the wiper arm, or the wiper element in the wiper blade as follows:

(a) To install the wiper blade on the wiper arm, slide the blade retainer into the U-shaped formation on the tip of the wiper arm until the release tab snaps into its locked position. Be certain that the pinch-release for the wiper element is oriented towards the end of the wiper blade that is nearest to the wiper pivot.

(b) To install the wiper element in the wiper blade, be certain that the metal element rails (vertebra) are properly seated in the slots on either side of the rubber element. Start at the wiper pivot end of the blade and slide the element through each pair of wiper blade claws. The element is fully

REMOVAL AND INSTALLATION (Continued)

installed when the claws on the wiper pivot end of the blade are engaged in the wiper element retaining pockets.

REAR

The rear wiper blade and element are serviced as a unit. If either the blade or the element is faulty or damaged, the entire unit must be replaced. To remove the rear wiper blade, proceed as follows:

(1) Lift the rear wiper arm to raise the wiper blade and element off of the liftgate glass.

(2) Push the release tab under the arm tip and slide the blade away from the tip towards the rear wiper motor output shaft end of the arm (Fig. 4).

(3) To install the wiper blade on the wiper arm, slide the blade retainer into the U-shaped formation on the tip of the wiper arm until the release tab snaps into its locked position. Be certain that the pinch-release clip for the wiper element is oriented towards the end of the wiper blade that is nearest to the rear wiper motor output shaft.

WIPER ARM

CAUTION: The use of a screwdriver or other prying tool to remove a wiper arm may distort it. This distortion could allow the arm to come off of the pivot shaft, regardless of how carefully it is installed.

FRONT

(1) Open the hood of the vehicle.

(2) Lift the wiper arm to permit the latch to be pulled out to its holding position, then release the arm (Fig. 6). The arm will remain off the windshield with the latch in this position.

(3) Remove the arm from the pivot using a rocking motion.

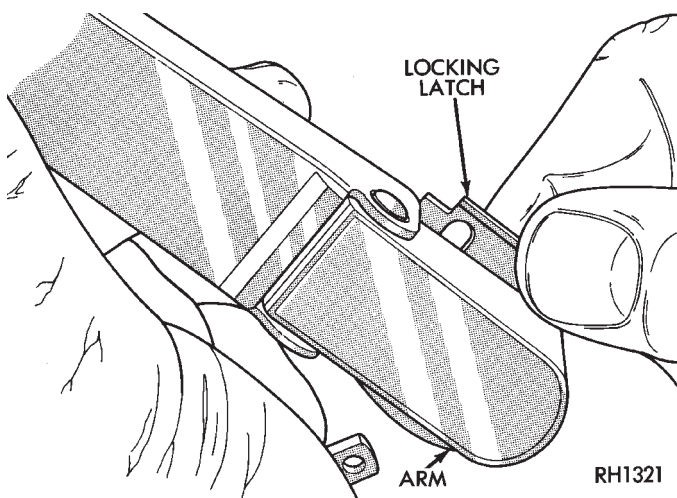


Fig. 6 Wiper Arm Remove/Install

(4) Install the arm and blade with the wiper motor in the Park position. See the Front Wiper Arm Installation illustration (Fig. 7).

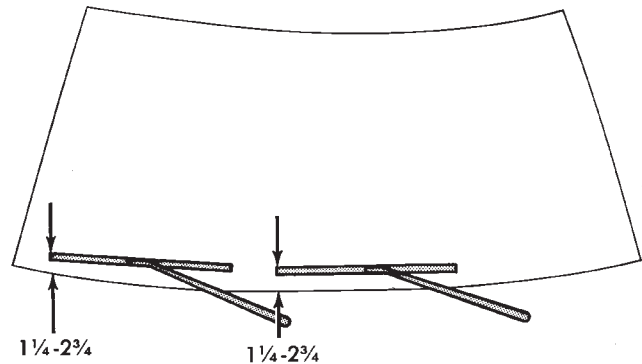


Fig. 7 Front Wiper Arm Installation

(5) Mount the arms on the pivot shafts so that the distance from the lower edge of the wiper arm tip to the upper edge of the lower windshield moulding is:

- 25 to 52 mm (0.98 to 2.04 inch) on the driver side
- 33 to 62 mm (1.29 to 2.44 inch) on the passenger side.

(6) Lift the wiper arm away from the windshield slightly to relieve the spring tension on the latch. Push the latch into the locked position and slowly release the arm until the wiper blade rests on the windshield.

(7) Operate the wipers with the windshield glass wet, then turn the wiper switch to the Off position. Check for the correct wiper arm positioning and readjust if required.

REAR

(1) Remove the wiper arm assembly by lifting the pivot cover and removing the retaining nut (Fig. 8).

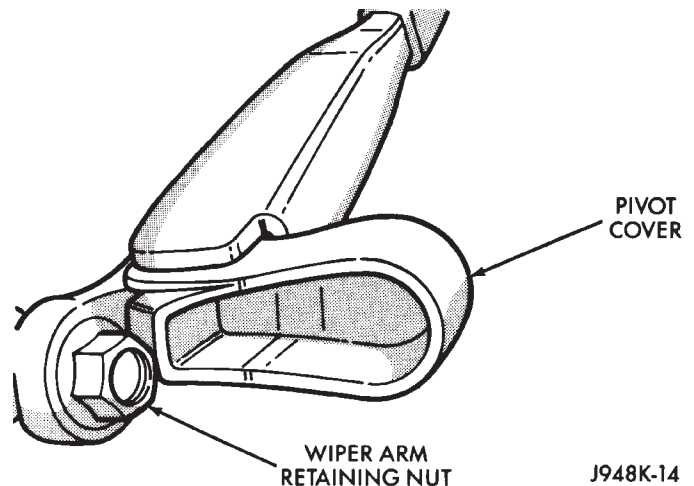


Fig. 8 Rear Wiper Arm Remove/Install

REMOVAL AND INSTALLATION (Continued)

(2) Remove the wiper arm from the motor output shaft using a rocking motion.

(3) Install the rear wiper arm with the wiper motor in the Park position. Place the rear wiper blade in the Installation position on the ramp (Fig. 9) and tighten the retaining nut to 18 N·m (160 in. lbs.).

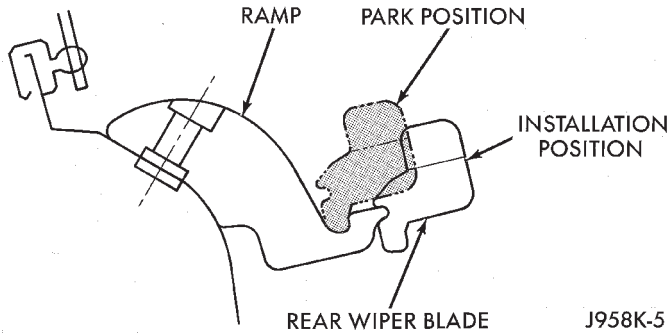


Fig. 9 Rear Wiper Arm Installation

(4) Close the pivot cover and move the rear wiper blade to the Park position on the ramp.

WIPER MOTOR

FRONT

- (1) Disconnect and isolate the battery negative cable.
- (2) Remove the wiper arms from the wiper pivots. See Wiper Arm in this group for the procedures.
- (3) Remove the screws that secure the cowl plenum cover/grille panel to the cowl top panel.
- (4) Lift the cowl plenum cover/grille panel from the vehicle far enough to access the windshield washer nozzle plumbing.
- (5) Disconnect the windshield washer supply hose from the tee fitting.
- (6) Carefully remove the cowl plenum cover/grille panel from the vehicle and set it aside.
- (7) Remove the five screws that secure the wiper module to the cowl plenum mounting bracket (Fig. 10).
- (8) Move the wiper module far enough to access the wiper motor wire harness connector.
- (9) Unplug the wiper motor wire harness connector from the wiper motor.
- (10) Remove the wiper module from the cowl plenum as a unit.
- (11) Turn the wiper module over and remove the nut that secures the wiper motor crank arm to the wiper motor output shaft.
- (12) Remove the three screws that secure the wiper motor to the wiper module mounting bracket.
- (13) Remove the wiper motor from the wiper module bracket.

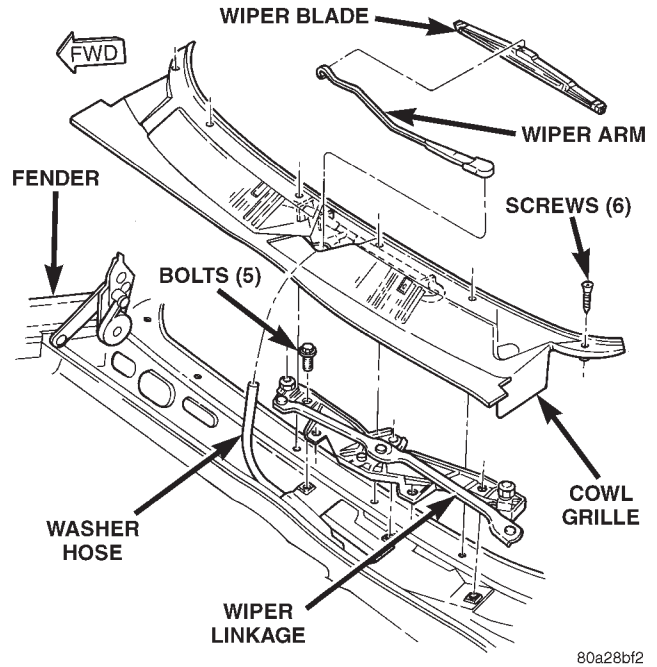


Fig. 10 Wiper Linkage Module Remove/Install

(14) Reverse the removal procedures to install. Tighten the mounting hardware as follows:

- Wiper motor screws - 6 N·m (53 in. lbs.)
- Crank arm nut - 11.5 N·m (101 in. lbs.)
- Wiper module mounting screws - 7.9 N·m (70 in. lbs.).
- Cowl plenum cover/grille panel screws - 1.7 N·m (15 in. lbs.).

REAR

- (1) Disconnect and isolate the battery negative cable.
- (2) From the outside of the liftgate, remove the rear wiper arm from the rear wiper motor output shaft. See Wiper Arm in this group for the procedures.
- (3) From the outside of the liftgate, remove the rear wiper motor output shaft nut (Fig. 11).
- (4) Remove the external bezel and gasket from the rear wiper motor output shaft.
- (5) From the inside of the liftgate, remove the liftgate inner trim panel. Refer to Group 23 - Body for the procedures.
- (6) Unplug the rear wiper motor wire harness connector.
- (7) Remove the screws that secure the wiper motor to the liftgate inner panel.
- (8) Remove the rear wiper motor from the liftgate.
- (9) Reverse the removal procedures to install. Tighten the mounting hardware as follows:
 - Motor mounting screws - 1.3 N·m (13 in. lbs.)
 - Wiper motor output shaft nut - 5 N·m (42 in. lbs.).

REMOVAL AND INSTALLATION (Continued)

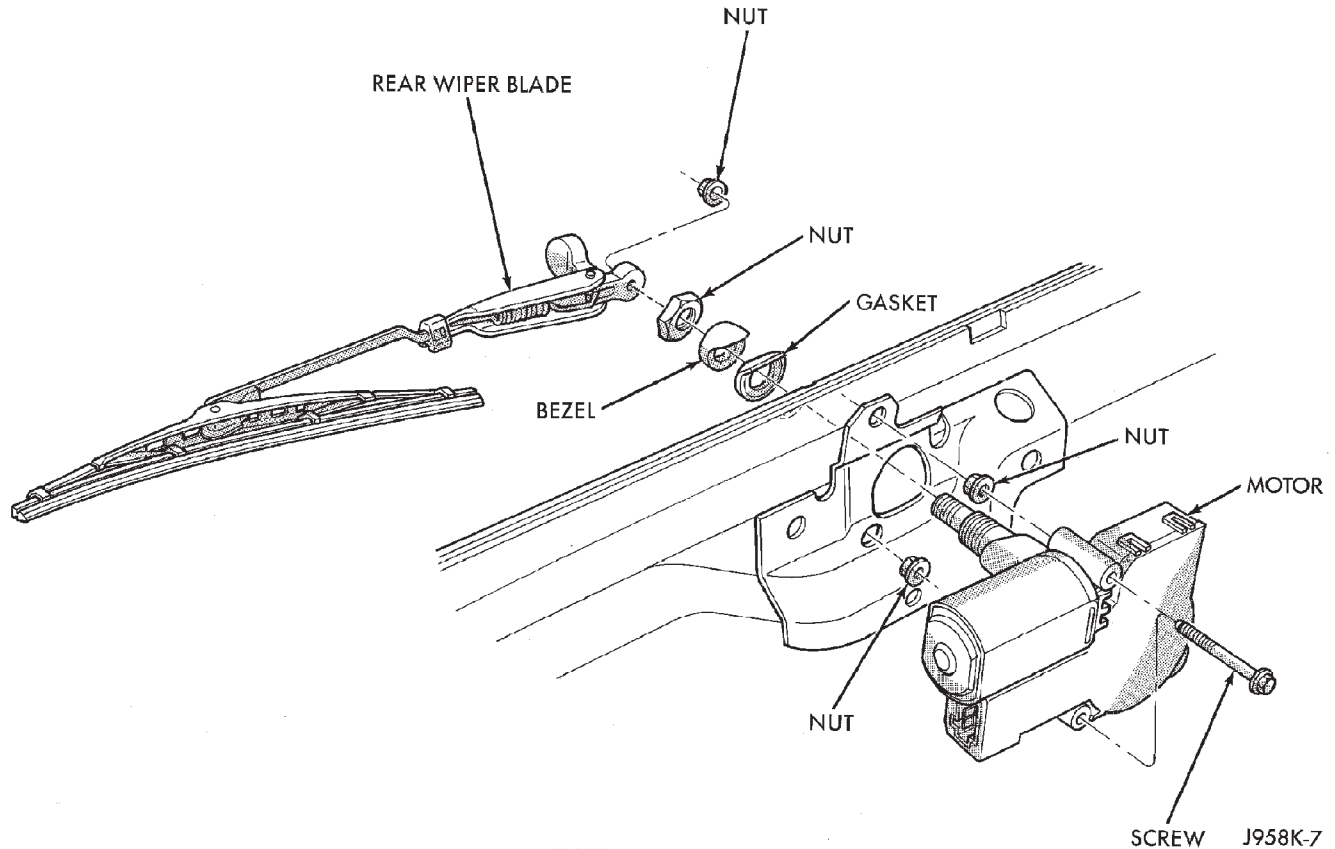


Fig. 11 Rear Wiper Motor Remove/Install

WIPER LINKAGE AND PIVOT

The wiper linkage and pivots can only be removed from or installed in the vehicle as a unit with the wiper motor. See Wiper Motor in this group for the service procedures.

INTERMITTENT WIPE RELAY

- (1) Disconnect and isolate the battery negative cable.
- (2) Remove the cover from the Power Distribution Center (PDC) (Fig. 12).
- (3) Refer to the label on the PDC for intermittent wipe relay identification and location.
- (4) Unplug the intermittent wipe relay from the PDC.
- (5) Install the intermittent wipe relay by aligning the relay terminals with the cavities in the PDC and pushing the relay firmly into place.
- (6) Install the PDC cover.
- (7) Connect the battery negative cable.
- (8) Test the relay operation.

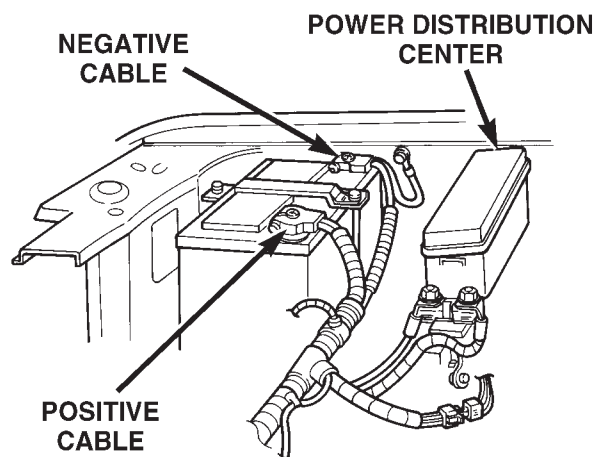


Fig. 12 Power Distribution Center

80a7233a

REMOVAL AND INSTALLATION (Continued)

WIPER SWITCH AND WASHER SWITCH

FRONT

WARNING: ON VEHICLES EQUIPPED WITH AIR-BAGS, REFER TO GROUP 8M - PASSIVE RESTRAINT SYSTEMS BEFORE ATTEMPTING ANY STEERING WHEEL, STEERING COLUMN, OR INSTRUMENT PANEL COMPONENT DIAGNOSIS OR SERVICE. FAILURE TO TAKE THE PROPER PRECAUTIONS COULD RESULT IN ACCIDENTAL AIR-BAG DEPLOYMENT AND POSSIBLE PERSONAL INJURY.

- (1) Disconnect and isolate the battery negative cable.
- (2) If the vehicle is so equipped, remove the tilt steering column lever.
- (3) Using a trim stick or another suitable wide flat-bladed tool, pry gently around the perimeter edges of both instrument panel switch pod bezels to release the snap clip retainers. Remove both bezels from the instrument panel.
- (4) Remove the one screw on each side of the steering column that secures the upper edge of the steering column opening cover/knee blocker to the instrument panel (Fig. 13).

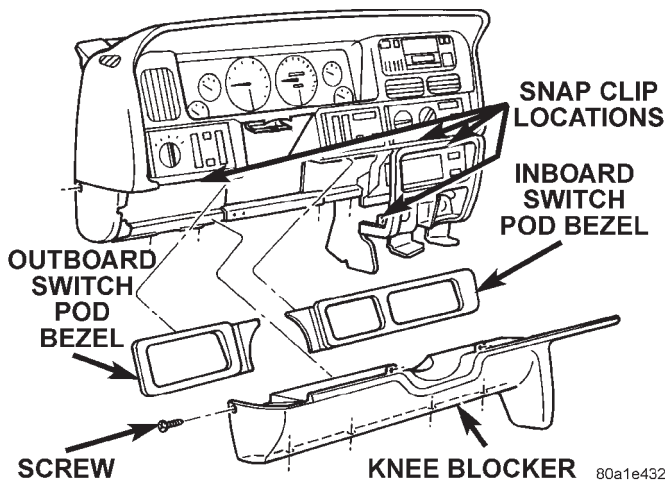


Fig. 13 Steering Column Opening Cover/Knee Blocker Remove/Install

- (5) Remove the one screw that secures the steering column opening cover/knee blocker to the outboard end of the instrument panel.
- (6) Remove the four screws that secure the lower edge of the steering column opening cover/knee blocker to the lower instrument panel reinforcement.
- (7) Using a trim stick or another suitable wide flat-bladed tool, gently pry the edges of the steering column opening cover/knee blocker away from the instrument panel at the snap clip retainer locations (Fig. 13).

- (8) Remove the steering column opening cover/knee blocker from the instrument panel.
- (9) Remove both the upper and lower shrouds from the steering column (Fig. 14).

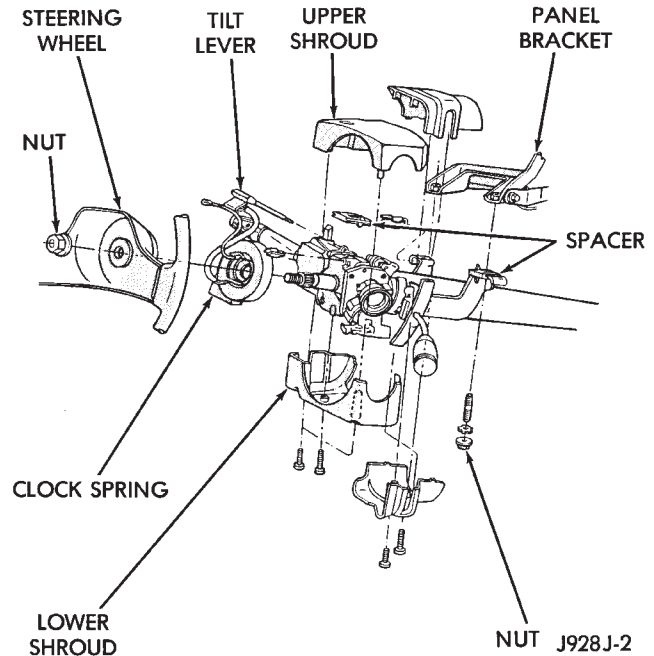


Fig. 14 Steering Column Shrouds Remove/Install - Typical

- (10) Remove the lower fixed column shroud.
- (11) Loosen the nuts that secure the steering column upper mounting bracket to the dash panel steering column support bracket studs. Lower the column far enough to move the upper fixed column shroud.
- (12) Move the upper fixed column shroud far enough to access the rear of the multi-function switch (Fig. 15).
- (13) Remove the tamper proof mounting screws (a Snap On tamper proof torx bit TTXR20B2 or equivalent).

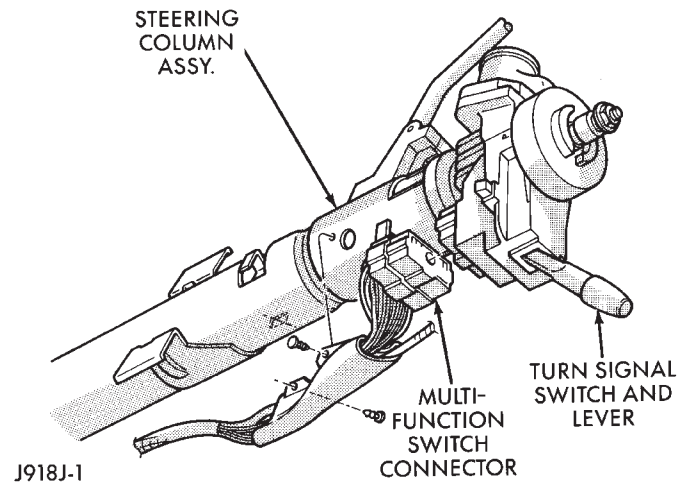


Fig. 15 Multi-Function Switch Connector - Typical

REMOVAL AND INSTALLATION (Continued)

lent is required) that secure the multi-function switch to the steering column.

(14) Gently pull the switch away from the steering column far enough to access and loosen the multi-function switch wire harness connector screw. The screw will remain in the wire harness connector.

(15) Unplug the wire harness connector from the multi-function switch.

(16) Reverse the removal procedures to install. Tighten the fasteners as follows:

- Multi-function switch wire harness connector screw - 2 N·m (17 in. lbs.)
- Multi-function switch mounting screws - 2 N·m (17 in. lbs.)
- Steering column mounting nuts - 12 N·m (110 in. lbs.).

REAR

WARNING: ON VEHICLES EQUIPPED WITH AIRBAGS, REFER TO GROUP 8M - PASSIVE RESTRAINT SYSTEMS BEFORE ATTEMPTING ANY STEERING WHEEL, STEERING COLUMN, OR INSTRUMENT PANEL COMPONENT DIAGNOSIS OR SERVICE. FAILURE TO TAKE THE PROPER PRECAUTIONS COULD RESULT IN ACCIDENTAL AIRBAG DEPLOYMENT AND POSSIBLE PERSONAL INJURY.

(1) Disconnect and isolate the battery negative cable.

(2) Using a trim stick or another suitable wide flat-bladed tool, pry gently around the perimeter edges of the inboard switch pod bezel to release the snap clip retainers. Remove the bezel from the instrument panel.

(3) Remove the three screws that secure the inboard switch pod to the instrument panel (Fig. 16).

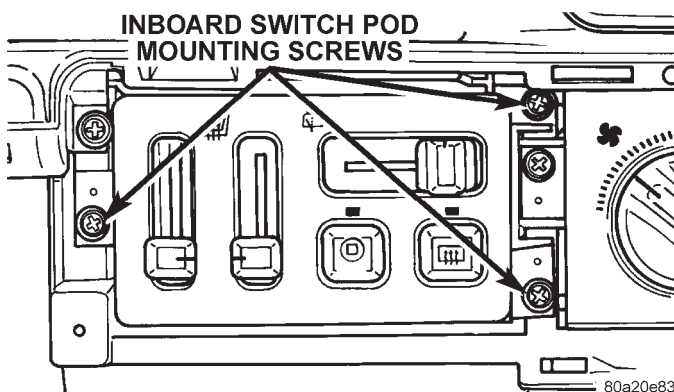


Fig. 16 Inboard Switch Pod Remove/Install

(4) Pull the inboard switch pod out from the instrument panel far enough to access and unplug the wire harness connectors.

(5) Remove the inboard switch pod from the instrument panel.

(6) Reverse the removal procedures to install. Tighten the switch mounting screws to 2.2 N·m (20 in. lbs.).

WASHER SYSTEM**WASHER RESERVOIR**

(1) Disconnect and isolate the battery negative cable.

(2) Remove the three screws that secure the washer reservoir to the inner fender shield (Fig. 17).

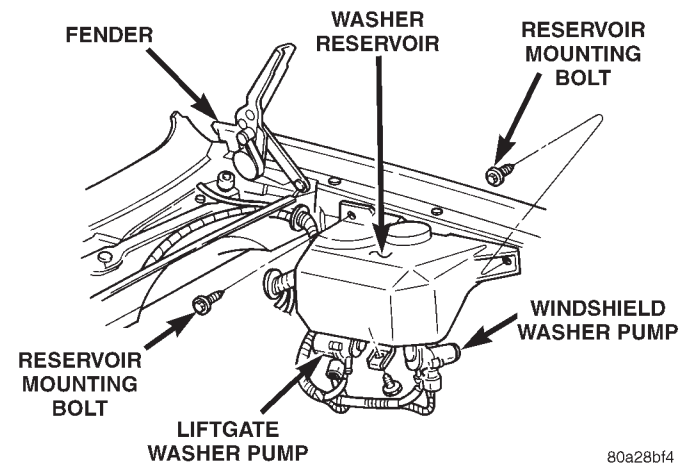


Fig. 17 Washer Reservoir Remove/Install

(3) Lift the reservoir far enough to access the washer pump wire harness connectors and hoses.

(4) Remove the washer supply hoses from the washer pumps and drain the washer fluid from the reservoir into a clean container for reuse.

(5) Unplug the wire harness connectors from the washer pumps and the washer fluid level sensor, if the vehicle is so equipped.

(6) Use a deep socket and extension inserted through the reservoir filler neck to remove the washer pump filter/nuts from the inside of the reservoir.

(7) Remove the washer pumps from the reservoir.

(8) If the vehicle is so equipped, remove the washer fluid level sensor from the reservoir. See Washer Fluid Level Sensor in this group for the procedures.

(9) Remove the rubber grommet seals from the reservoir and discard.

(10) Reverse the removal procedures to install. Always use new rubber grommet seals on the reservoir. Tighten the reservoir mounting screws to 4 N·m (35 in. lbs.).

REMOVAL AND INSTALLATION (Continued)

WASHER PUMP

- (1) Disconnect and isolate the battery negative cable.
- (2) Remove the washer supply hose from the barbed outlet nipple of the faulty washer pump and drain the washer fluid from the reservoir into a clean container for reuse.
- (3) Unplug the wire harness connector from the faulty washer pump.
- (4) Use a deep socket and extension inserted through the reservoir filler neck to remove the faulty washer pump filter/nut from the inside of the reservoir.
- (5) Remove the faulty washer pump from the reservoir.
- (6) Remove the rubber grommet seal from the reservoir and discard.
- (7) Reverse the removal procedures to install. Always use a new rubber grommet seal on the reservoir.

WASHER FLUID LEVEL SENSOR

- (1) Remove the washer reservoir from the vehicle. See Washer Reservoir in this group for the procedures.

NOTE: The pivoting float of the washer fluid sensor must be in a horizontal position within the reservoir in order to be removed. With the reservoir empty and in an upright position, the pivoting float will orient itself to the horizontal position when the sensor connector is pointed straight downwards.

- (2) Using a trim stick or another suitable wide flat-bladed tool, gently pry the washer fluid level sensor out of the rubber grommet seal. Care must be taken not to damage the reservoir.
- (3) Remove the rubber grommet seal from the reservoir and discard.
- (4) Reverse the removal procedures to install. Always use a new rubber grommet seal on the reservoir.

WASHER NOZZLE

FRONT

- (1) Use a small screwdriver to gently pry the snap-fit nozzle loose from the opening in the cowl plenum cover/grille panel.

- (2) Pull the nozzle out from the cowl plenum cover/grille panel far enough to access and disconnect the washer supply hose from the nozzle nipple.
- (3) Reverse the removal procedures to install.

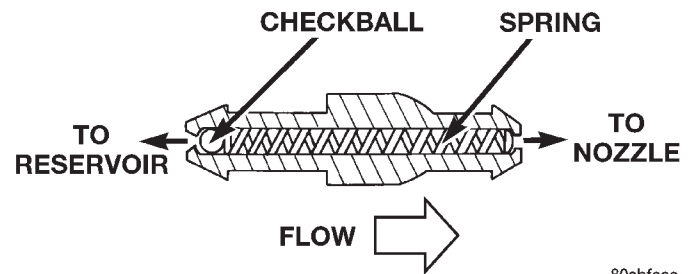
REAR

- (1) Using a trim stick or another suitable wide flat-bladed tool, pry gently at the lower edge of the rear washer nozzle to release the snap clips that secure it to the liftgate outer panel.
- (2) Pull the nozzle out from the liftgate outer panel far enough to access and disconnect the washer supply hose from the nozzle nipple.
- (3) Reverse the removal procedures to install.

CHECK VALVE

A check valve is located in the washer supply line in the liftgate opening header, near the grommet where the supply hose exits the vehicle body to the liftgate.

- (1) Remove the upper liftgate opening trim panel. Refer to Group 23 - Body for the procedures.
- (2) Disconnect the washer supply hoses from the barbed nipples on each end of the rear washer system check valve.
- (3) Remove the check valve from the vehicle.
- (4) When reinstalling the check valve, be certain the valve is properly oriented within the system flow (Fig. 18).
- (5) Reverse the remaining removal procedures to complete the installation.



80abfece

Fig. 18 Washer System Check Valve

LAMPS

CONTENTS

	page		page
BULB APPLICATION	9	LAMP SERVICE	6
LAMP BULB SERVICE	4	LAMP SYSTEMS	8
LAMP DIAGNOSIS	1	SERVICE PROCEDURES	2

LAMP DIAGNOSIS

INDEX

	page		page
GENERAL INFORMATION		DIAGNOSIS AND TESTING	
HEADLAMP LEVELING MOTOR	1	HEADLAMP MOTOR DIAGNOSIS	1

GENERAL INFORMATION

HEADLAMP LEVELING MOTOR

This vehicle is may be equipped with a manual headlamp leveling system. This system allows the driver to adjust the headlamp beam height depending on passenger or cargo load. The headlamp beam

height is controlled by a motor attached to each headlamp and is adjusted by a switch located on the console.

DIAGNOSIS AND TESTING

HEADLAMP MOTOR DIAGNOSIS

CONDITION	POSSIBLE CAUSE	CORRECTION
ONE MOTOR DOES NOT OPERATE	1. Poor connection at motor. 2. No voltage at motor. 3. Defective motor.	1. Secure connector on motor. 2. Repair circuit. 3. Replace motor.
MOTORS DO NOT OPERATE	1. No voltage at switch. 2. No voltage at motors. 3. Poor connection at motors. 4. Both motors defective.	1. Repair circuit or replace fuse. Refer to Group 8W. 2. Repair circuit or replace switch. 3. Secure connector on motors. 4. Replace motors.

SERVICE PROCEDURES

INDEX

	page	page
SERVICE PROCEDURES		
HEADLAMP ALIGNMENT	2	

SERVICE PROCEDURES

HEADLAMP ALIGNMENT

VEHICLE PREPARATION

- (1) Verify headlamp dimmer switch and high beam indicator operation.
- (2) If equipped with a motorized headlamp leveling system, ensure the headlamp leveling switch is in the 0 position.
- (3) Correct defective components that could hinder proper headlamp alignment.
- (4) Verify proper tire inflation.
- (5) Clean headlamp lenses.
- (6) Verify that luggage area is not heavily loaded.
- (7) Fuel tank should be FULL. Add 2.94 kg (6.5 lbs.) of weight over the fuel tank for each estimated gallon of missing fuel.

ALIGNMENT SCREEN PREPARATION

- (1) Position vehicle on a level surface perpendicular to a flat wall 10 meters away from front of headlamp lens (Fig. 1).
- (2) If necessary, tape a line on the floor 10 meters away from and parallel to the wall.
- (3) Measure from the floor up 1.27 meters (5 feet) and tape a line on the wall at the centerline of the vehicle. Sight along the centerline of the vehicle (from rear of vehicle forward) to verify accuracy of the line placement.
- (4) Rock vehicle side-to-side three times to allow suspension to stabilize.

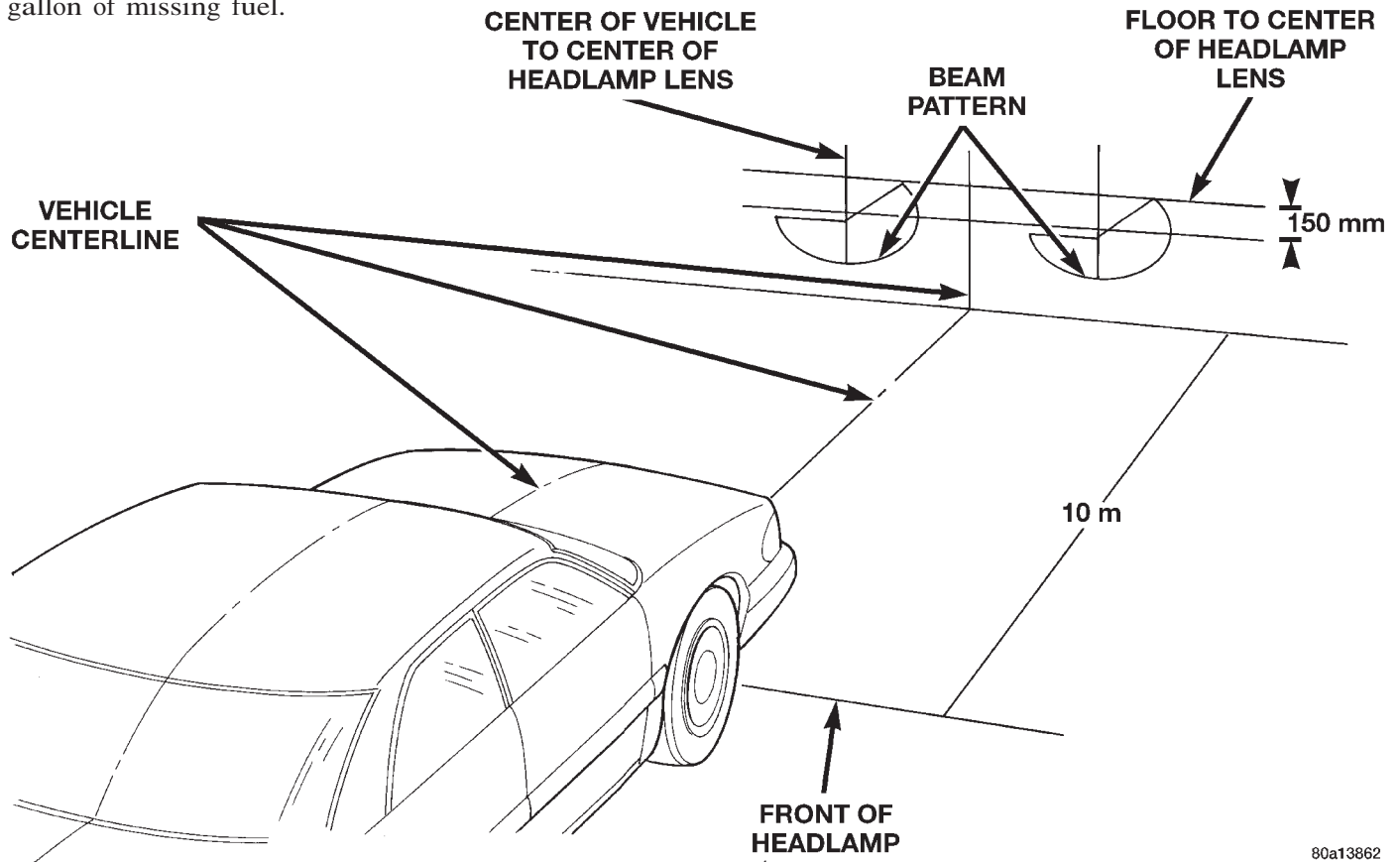


Fig. 1 Headlamp Alignment Screen—Left Hand Drive

SERVICE PROCEDURES (Continued)

(5) Jounce front suspension three times by pushing downward on front bumper and releasing.

(6) Measure the distance from the center of headlamp lens to the floor. Transfer measurement to the alignment screen (with tape).

(7) Place a tape line 150 mm below and parallel to the center of headlamp lens to the floor tape mark. Use this for up/down alignment reference.

(8) Measure distance from the centerline of the vehicle to the center of each headlamp being aligned. Transfer measurements to screen (with tape) to each side of vehicle centerline. Use these lines for left/right adjustment reference .

HEADLAMP ADJUSTMENT

A properly aimed low beam headlamp will project the top edge of high intensity pattern on screen from 150 mm below headlamp centerline (Fig. 1). The angle between the horizontal and the inclined part of the light-dark boundary may not vary more than 10 cm to the right or left of the vertical through the center mark.

To adjust headlamp aim, rotate the headlamp alignment screws to achieve the pattern specified on the alignment screen.

LAMP BULB SERVICE

INDEX

	page		page
REMOVAL AND INSTALLATION		REAR FOG LAMP BULB	5
HEADLAMP BULB	4	SIDE REPEATER LAMP BULB	4

REMOVAL AND INSTALLATION

HEADLAMP BULB

REMOVAL

- (1) Remove headlamp.
- (2) Disengage electrical connector.
- (3) Remove protective boot from rear of headlamp (Fig. 1).
- (4) Disengage bulb retaining clip (Fig. 2).
- (5) Pull the bulb straight out from the housing .

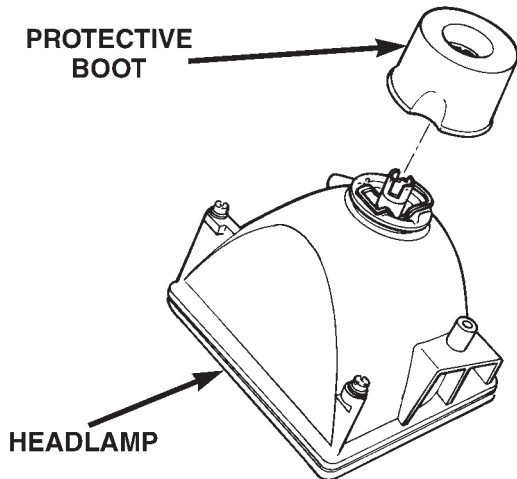


Fig. 1 Protective Boot

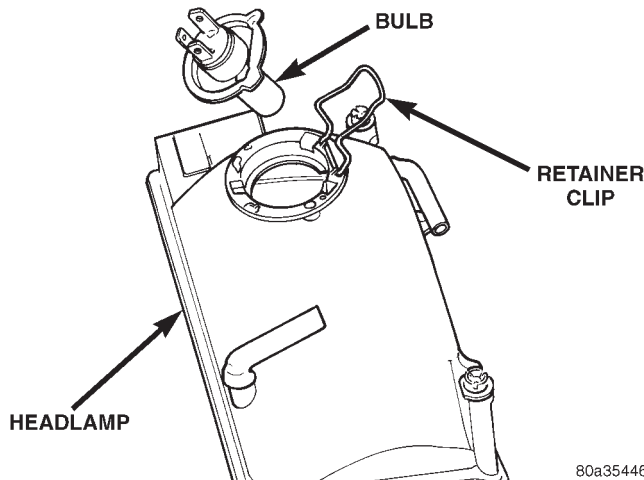


Fig. 2 Retaining Clip

INSTALLATION

CAUTION: Do not touch the bulb glass with fingers or other oily surfaces. Reduced bulb life will result.

- (1) Position bulb assembly in the lamp housing.
- (2) Engage bulb retaining clip.
- (3) Install protective boot on rear of headlamp.
- (4) Engage electrical connector.
- (5) Install headlamp.

SIDE REPEATER LAMP BULB

REMOVAL

- (1) Insert a flat blade or similar tool between lamp and fender opening and pry the lamp away from the fender (Fig. 3). The retaining tabs are located at the top and bottom of the lamp.
- (2) Twist lamp 1/4 turn clockwise and pull lamp from socket (Fig. 3).
- (3) Twist bulb 1/4 turn and pull bulb from socket .

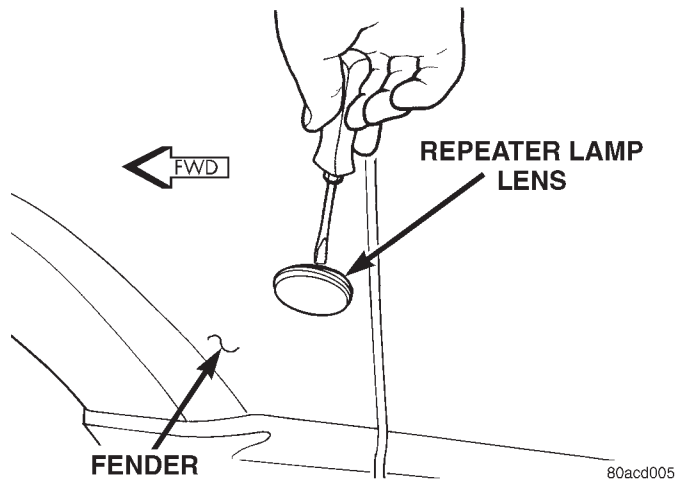


Fig. 3 Repeater Lamp Lens

INSTALLATION

- (1) Position bulb in lamp socket and twist bulb 1/4 turn.
- (2) Push lamp on socket and turn 1/4 turn counter-clockwise.
- (3) Push lamp into fender opening.

REMOVAL AND INSTALLATION (Continued)

REAR FOG LAMP BULB

REMOVAL

- (1) Remove the tail lamp.
- (2) Grasp the fog lamp bulb socket and rotate counterclockwise (Fig. 4). Separate socket from lamp.
- (3) Pull the bulb from the socket .

INSTALLATION

- (1) Push the bulb into the socket.
- (2) Position the bulb socket in the lamp and rotate clockwise.
- (3) Install the tail lamp.

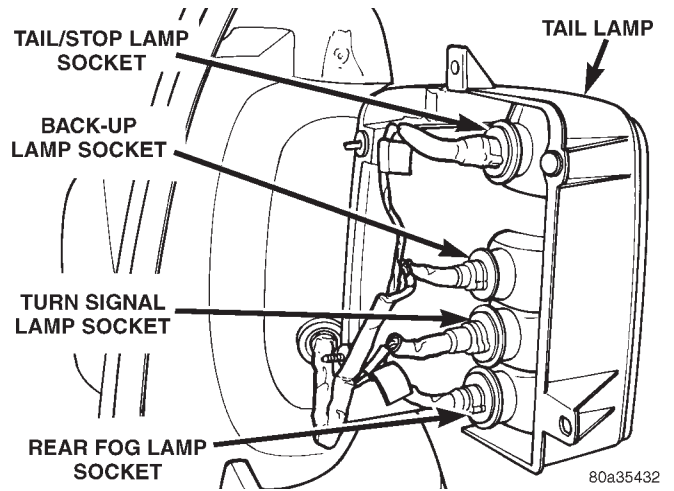


Fig. 4 Fog Lamp Bulb

80a35432

LAMP SERVICE

INDEX

	page		page
REMOVAL AND INSTALLATION		REAR FOG LAMP	6
HEADLAMP	6	SIDE REPEATER LAMP	6
REAR BUMPER REFLECTOR	6		

REMOVAL AND INSTALLATION

HEADLAMP

REMOVAL

- (1) Remove the park lamp.
- (2) Remove the metal clip retaining the upper pivot of the headlamp to the headlamp leveling motor.
- (3) Pull the headlamp from the grille opening reinforcement (GOR).
- (4) Disengage the electrical connector from the rear of the headlamp

INSTALLATION

- (1) Engage the electrical connector on the rear of the headlamp
- (2) Position the headlamp in the (GOR) and press into place.
- (3) Install the metal clip retaining the upper pivot of the headlamp to the headlamp leveling motor.
- (4) Install the park lamp.

SIDE REPEATER LAMP

REMOVAL

- (1) Insert a small flat blade between lamp and body panel. Disengage lamp retaining tabs (Fig. 1).
- (2) Twist bulb socket 1/4 turn and separate bulb socket from lamp (Fig. 2) .

INSTALLATION

- (1) Position socket in lamp and twist socket 1/4 turn.
- (2) Position lamp into body opening and push into place.

REAR FOG LAMP

The rear fog lamp is integrated into the rear tail lamp. Refer to the Rear Tail Lamp Removal/Installation procedure.

REAR BUMPER REFLECTOR

REMOVAL

- (1) From the underside of the vehicle, remove the nut attaching the reflector to the backside of the rear bumper.

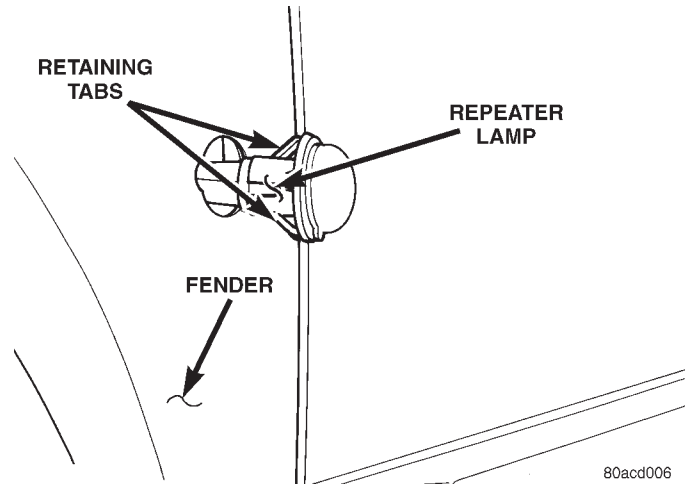


Fig. 1 Repeater Lamp Retaining Tabs

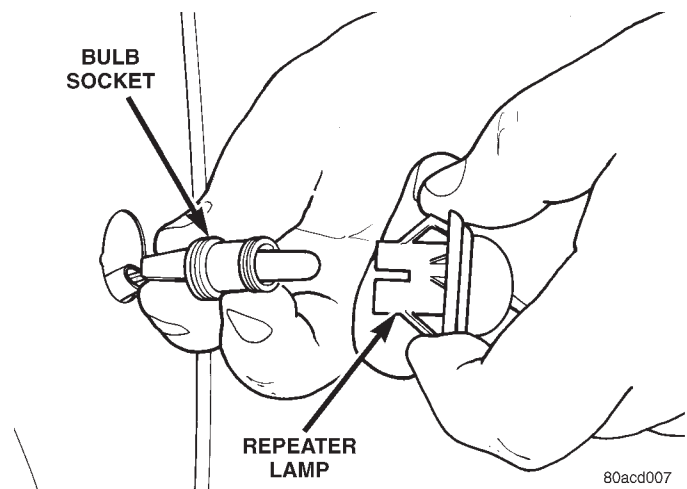


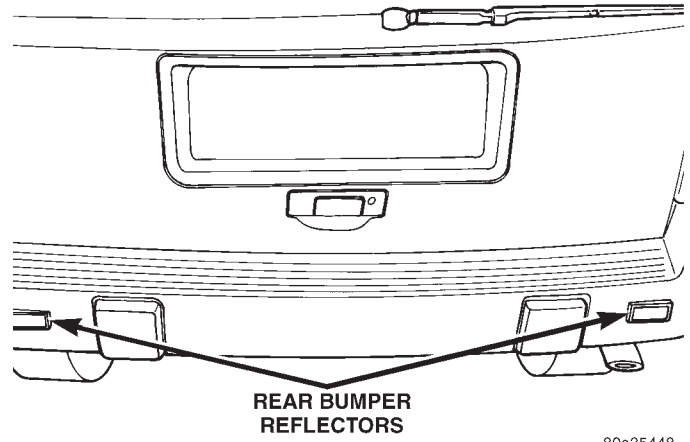
Fig. 2 Repeater Lamp

- (2) Separate the reflector from the rear bumper.

REMOVAL AND INSTALLATION (Continued)

INSTALLATION

- (1) Position the reflector on the rear bumper (Fig. 3).
- (2) Install the nut attaching the reflector to the rear bumper .



80a35448

Fig. 3 Rear Bumper Reflector

LAMP SYSTEMS

INDEX

	page	page
REMOVAL AND INSTALLATION		
HEADLAMP LEVELING MOTOR	8	

REMOVAL AND INSTALLATION

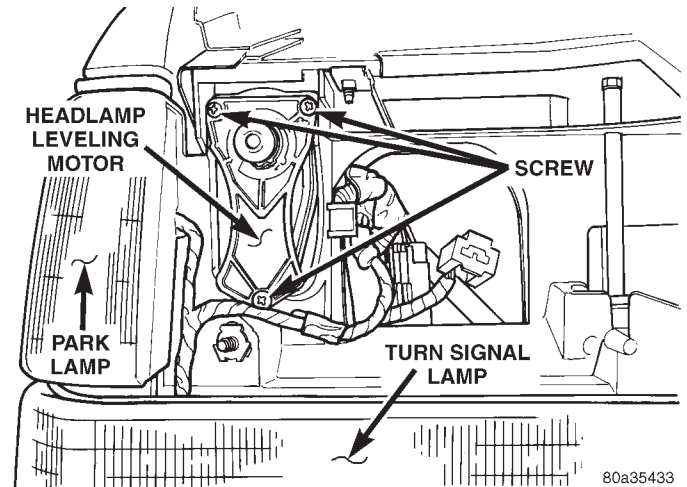
HEADLAMP LEVELING MOTOR

REMOVAL

- (1) Remove headlamp.
- (2) Remove screws attaching leveling motor to grille opening reinforcement (GOR) (Fig. 1).
- (3) Gently push leveling motor downward and pull from GOR.
- (4) Squeeze electrical connector tabs inward and pull connector from leveling motor.
- (5) Separate leveling motor from vehicle .

INSTALLATION

- (1) Engage electrical connector to leveling motor.
- (2) Position leveling motor in GOR and install screws.
- (3) Install headlamp.



80a35433

Fig. 1 Headlamp Leveling Motor

BULB APPLICATION

INDEX

page page

SPECIFICATIONS
EXTERIOR LAMPS 9

SPECIFICATIONS

EXTERIOR LAMPS

LAMP	BULB
Front Fog Lamp	H3
Front Turn Signal Lamp	P27/7W
Headlamp	H4
License Plate Lamp	W5W
Park Lamp	W3W
Park Lamp (Japan Only)	W3W
Rear Fog Lamp	P27/7W
Rear Turn Signal Lamp	P27/7W
Side Repeater Lamp	T4W
Stop Lamp	P27/7W
Tail Lamp	P27/7W
Reverse Lamp	P27/7W

LAMPS

CONTENTS

	page		page
BULB APPLICATION	9	LAMP SERVICE	6
LAMP BULB SERVICE	4	LAMP SYSTEMS	8
LAMP DIAGNOSIS	1	SERVICE PROCEDURES	2

LAMP DIAGNOSIS

INDEX

	page		page
GENERAL INFORMATION		DIAGNOSIS AND TESTING	
HEADLAMP LEVELING MOTOR	1	HEADLAMP MOTOR DIAGNOSIS	1

GENERAL INFORMATION

HEADLAMP LEVELING MOTOR

This vehicle is may be equipped with a manual headlamp leveling system. This system allows the driver to adjust the headlamp beam height depending on passenger or cargo load. The headlamp beam

height is controlled by a motor attached to each headlamp and is adjusted by a switch located on the console.

DIAGNOSIS AND TESTING

HEADLAMP MOTOR DIAGNOSIS

CONDITION	POSSIBLE CAUSE	CORRECTION
ONE MOTOR DOES NOT OPERATE	1. Poor connection at motor. 2. No voltage at motor. 3. Defective motor.	1. Secure connector on motor. 2. Repair circuit. 3. Replace motor.
MOTORS DO NOT OPERATE	1. No voltage at switch. 2. No voltage at motors. 3. Poor connection at motors. 4. Both motors defective.	1. Repair circuit or replace fuse. Refer to Group 8W. 2. Repair circuit or replace switch. 3. Secure connector on motors. 4. Replace motors.

SERVICE PROCEDURES

INDEX

page

SERVICE PROCEDURES
 HEADLAMP ALIGNMENT 2

SERVICE PROCEDURES

HEADLAMP ALIGNMENT

VEHICLE PREPARATION

- (1) Verify headlamp dimmer switch and high beam indicator operation.
- (2) If equipped with a motorized headlamp leveling system, ensure the headlamp leveling switch is in the 0 position.
- (3) Correct defective components that could hinder proper headlamp alignment.
- (4) Verify proper tire inflation.
- (5) Clean headlamp lenses.
- (6) Verify that luggage area is not heavily loaded.
- (7) Fuel tank should be FULL. Add 2.94 kg (6.5 lbs.) of weight over the fuel tank for each estimated gallon of missing fuel.

ALIGNMENT SCREEN PREPARATION

- (1) Position vehicle on a level surface perpendicular to a flat wall 10 meters away from front of headlamp lens (Fig. 1).
- (2) If necessary, tape a line on the floor 10 meters away from and parallel to the wall.
- (3) Measure from the floor up 1.27 meters (5 feet) and tape a line on the wall at the centerline of the vehicle. Sight along the centerline of the vehicle (from rear of vehicle forward) to verify accuracy of the line placement.
- (4) Rock vehicle side-to-side three times to allow suspension to stabilize.

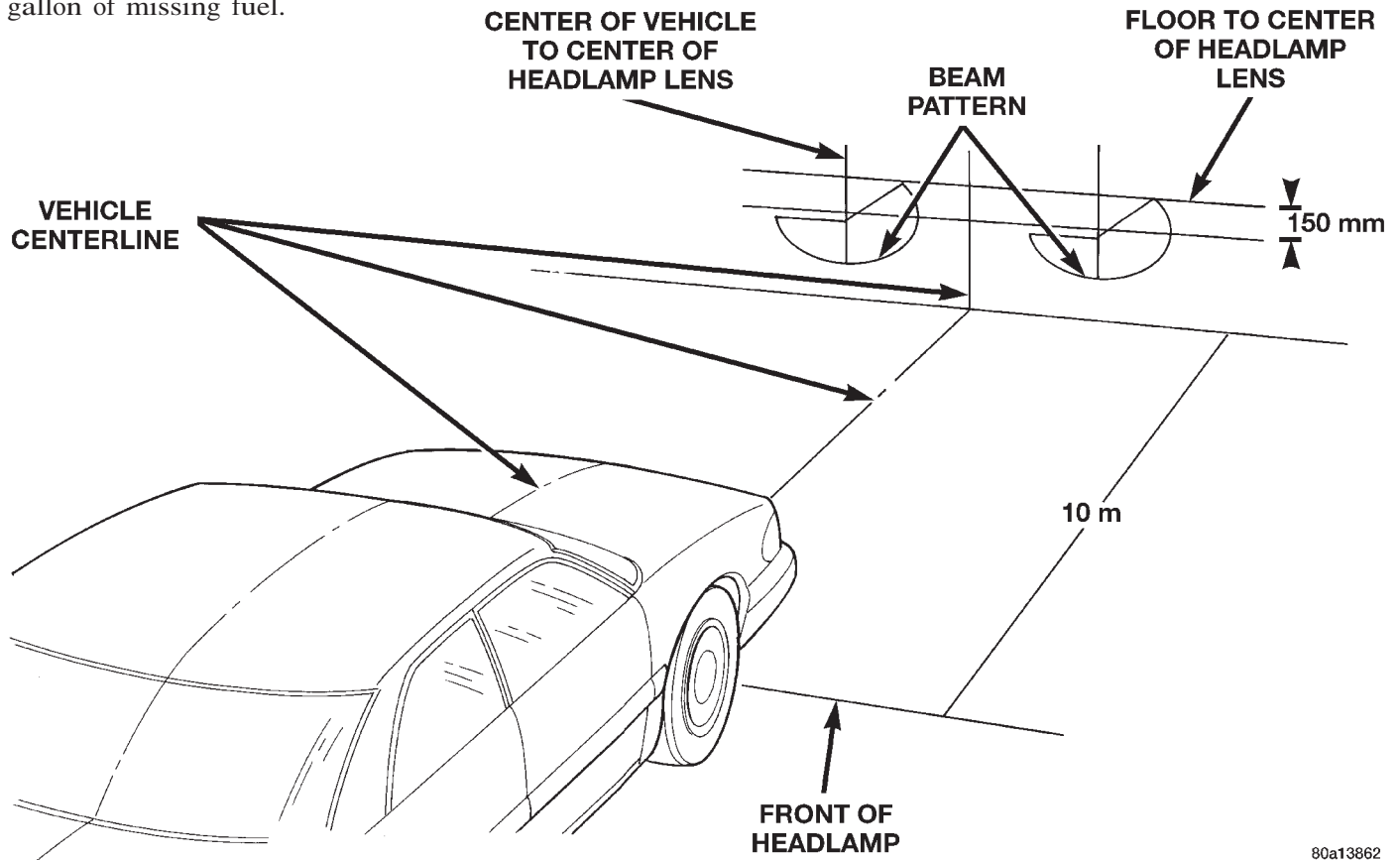


Fig. 1 Headlamp Alignment Screen—Left Hand Drive

SERVICE PROCEDURES (Continued)

(5) Jounce front suspension three times by pushing downward on front bumper and releasing.

(6) Measure the distance from the center of headlamp lens to the floor. Transfer measurement to the alignment screen (with tape).

(7) Place a tape line 150 mm below and parallel to the center of headlamp lens to the floor tape mark. Use this for up/down alignment reference.

(8) Measure distance from the centerline of the vehicle to the center of each headlamp being aligned. Transfer measurements to screen (with tape) to each side of vehicle centerline. Use these lines for left/right adjustment reference.

HEADLAMP ADJUSTMENT

A properly aimed low beam headlamp will project the top edge of high intensity pattern on screen from 150 mm below headlamp centerline (Fig. 1). The angle between the horizontal and the inclined part of the light-dark boundary may not vary more than 10 cm to the right or left of the vertical through the center mark.

To adjust headlamp aim, rotate the headlamp alignment screws to achieve the pattern specified on the alignment screen.

LAMP BULB SERVICE

INDEX

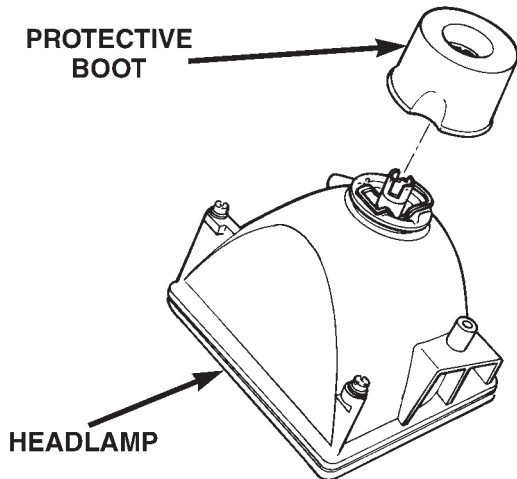
	page		page
REMOVAL AND INSTALLATION		REAR FOG LAMP BULB	5
HEADLAMP BULB	4	SIDE REPEATER LAMP BULB	4

REMOVAL AND INSTALLATION

HEADLAMP BULB

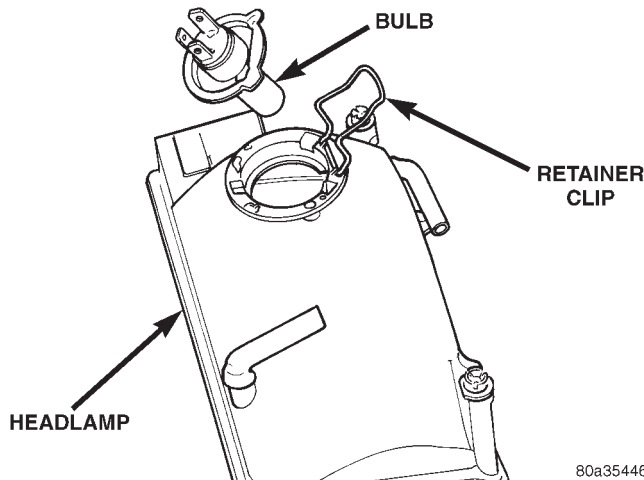
REMOVAL

- (1) Remove headlamp.
- (2) Disengage electrical connector.
- (3) Remove protective boot from rear of headlamp (Fig. 1).
- (4) Disengage bulb retaining clip (Fig. 2).
- (5) Pull the bulb straight out from the housing.



80a35447

Fig. 1 Protective Boot



80a35446

Fig. 2 Retaining Clip

INSTALLATION

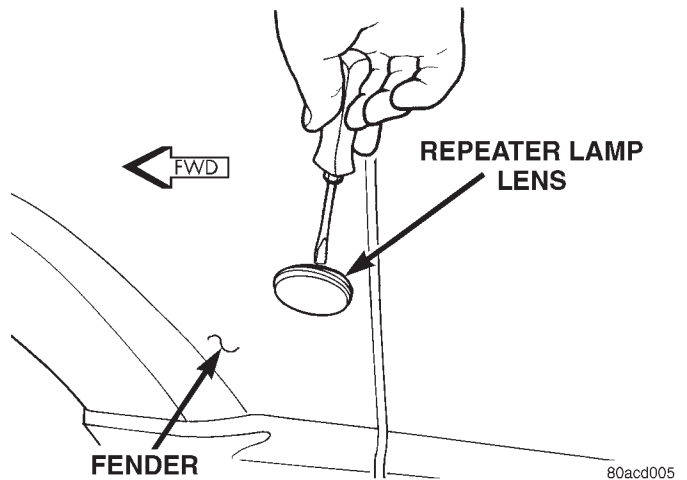
CAUTION: Do not touch the bulb glass with fingers or other oily surfaces. Reduced bulb life will result.

- (1) Position bulb assembly in the lamp housing.
- (2) Engage bulb retaining clip.
- (3) Install protective boot on rear of headlamp.
- (4) Engage electrical connector.
- (5) Install headlamp.

SIDE REPEATER LAMP BULB

REMOVAL

- (1) Insert a flat blade or similar tool between lamp and fender opening and pry the lamp away from the fender (Fig. 3). The retaining tabs are located at the top and bottom of the lamp.
- (2) Twist lamp 1/4 turn clockwise and pull lamp from socket (Fig. 3).
- (3) Twist bulb 1/4 turn and pull bulb from socket.



80acd005

Fig. 3 Repeater Lamp Lens

INSTALLATION

- (1) Position bulb in lamp socket and twist bulb 1/4 turn.
- (2) Push lamp on socket and turn 1/4 turn counter-clockwise.
- (3) Push lamp into fender opening.

REMOVAL AND INSTALLATION (Continued)

REAR FOG LAMP BULB

REMOVAL

- (1) Remove the tail lamp.
- (2) Grasp the fog lamp bulb socket and rotate counterclockwise (Fig. 4). Separate socket from lamp.
- (3) Pull the bulb from the socket.

INSTALLATION

- (1) Push the bulb into the socket.
- (2) Position the bulb socket in the lamp and rotate clockwise.
- (3) Install the tail lamp.

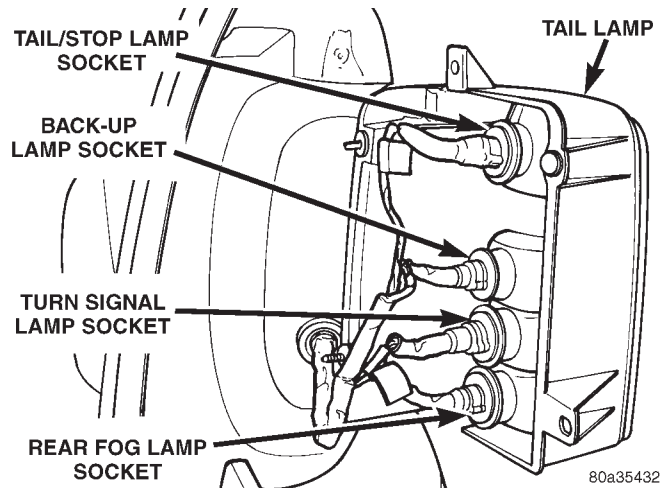


Fig. 4 Fog Lamp Bulb

LAMP SERVICE

INDEX

	page		page
REMOVAL AND INSTALLATION		REAR FOG LAMP	6
HEADLAMP	6	SIDE REPEATER LAMP	6
REAR BUMPER REFLECTOR	6		

REMOVAL AND INSTALLATION

HEADLAMP

REMOVAL

- (1) Remove the park lamp.
- (2) Remove the metal clip retaining the upper pivot of the headlamp to the headlamp leveling motor.
- (3) Pull the headlamp from the grille opening reinforcement (GOR).
- (4) Disengage the electrical connector from the rear of the headlamp.

INSTALLATION

- (1) Engage the electrical connector on the rear of the headlamp.
- (2) Position the headlamp in the (GOR) and press into place.
- (3) Install the metal clip retaining the upper pivot of the headlamp to the headlamp leveling motor.
- (4) Install the park lamp.

SIDE REPEATER LAMP

REMOVAL

- (1) Insert a small flat blade between lamp and body panel. Disengage lamp retaining tabs (Fig. 1).
- (2) Twist bulb socket 1/4 turn and separate bulb socket from lamp (Fig. 2).

INSTALLATION

- (1) Position socket in lamp and twist socket 1/4 turn.
- (2) Position lamp into body opening and push into place.

REAR FOG LAMP

The rear fog lamp is integrated into the rear tail lamp. Refer to the Rear Tail Lamp Removal/Installation procedure.

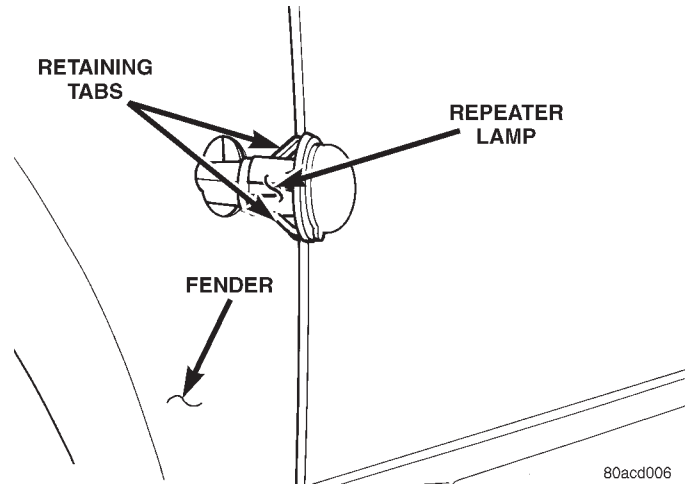


Fig. 1 Repeater Lamp Retaining Tabs

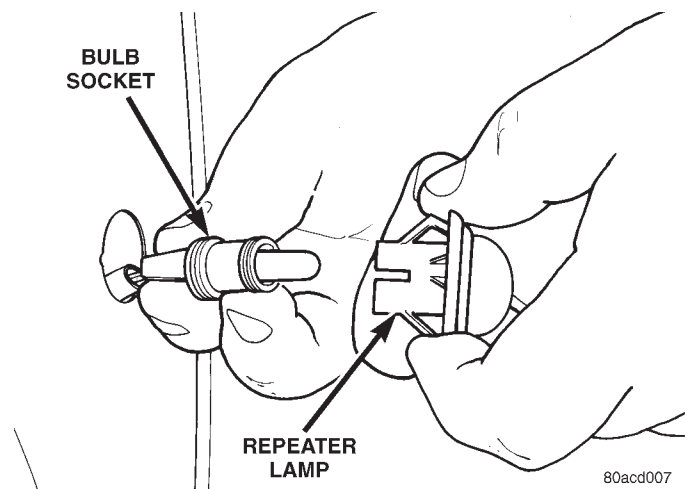


Fig. 2 Repeater Lamp

REAR BUMPER REFLECTOR

REMOVAL

- (1) From the underside of the vehicle, remove the nut attaching the reflector to the backside of the rear bumper.
- (2) Separate the reflector from the rear bumper.

REMOVAL AND INSTALLATION (Continued)

INSTALLATION

- (1) Position the reflector on the rear bumper (Fig. 3).
- (2) Install the nut attaching the reflector to the rear bumper.

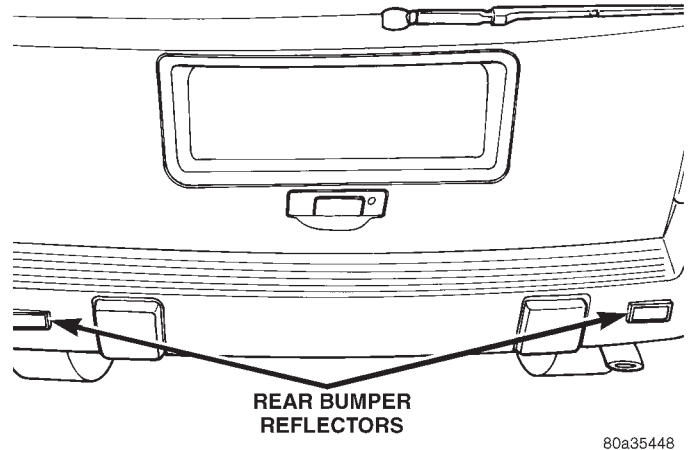


Fig. 3 Rear Bumper Reflector

LAMP SYSTEMS

INDEX

page

REMOVAL AND INSTALLATION	
HEADLAMP LEVELING MOTOR	8

REMOVAL AND INSTALLATION

HEADLAMP LEVELING MOTOR

REMOVAL

- (1) Remove headlamp.
- (2) Remove screws attaching leveling motor to grille opening reinforcement (GOR) (Fig. 1).
- (3) Gently push leveling motor downward and pull from GOR.
- (4) Squeeze electrical connector tabs inward and pull connector from leveling motor.
- (5) Separate leveling motor from vehicle.

INSTALLATION

- (1) Engage electrical connector to leveling motor.
- (2) Position leveling motor in GOR and install screws.
- (3) Install headlamp.

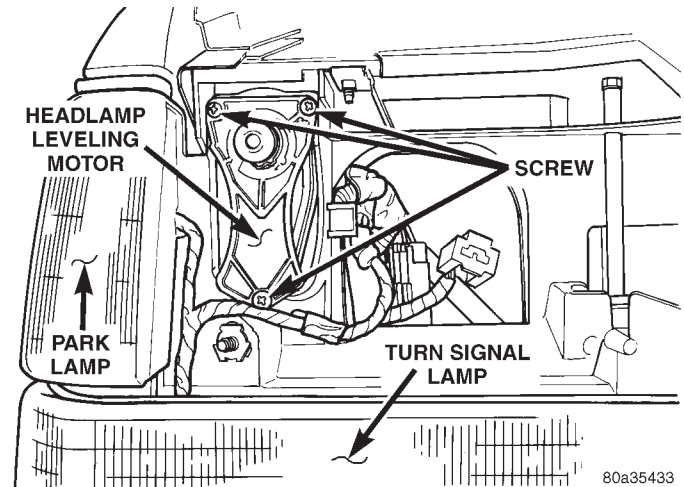


Fig. 1 Headlamp Leveling Motor

BULB APPLICATION

INDEX

page

SPECIFICATIONS
EXTERIOR LAMPS 9

SPECIFICATIONS

EXTERIOR LAMPS

LAMP	BULB
Front Fog Lamp	H3
Front Turn Signal Lamp	P27/7W
Headlamp	H4
License Plate Lamp	W5W
Park Lamp	W3W
Park Lamp (Japan Only)	W3W
Rear Fog Lamp	P27/7W
Rear Turn Signal Lamp	P27/7W
Side Repeater Lamp	T4W
Stop Lamp	P27/7W
Tail Lamp	P27/7W
Reverse Lamp	P27/7W

PASSIVE RESTRAINT SYSTEMS

CONTENTS

	page		page
GENERAL INFORMATION		REMOVAL AND INSTALLATION	
INTRODUCTION	1	AIRBAG CONTROL MODULE	8
DESCRIPTION AND OPERATION		AIRBAG MODULE	4
AIRBAG CONTROL MODULE	3	CLOCKSPRING	9
AIRBAG MODULE	2	DRIVER SIDE AIRBAG TRIM COVER AND HORN SWITCH	6
CLOCKSPRING	2	PASSENGER SIDE AIRBAG REAR MOUNTING BRACKET	7
IMPACT SENSOR	2	ADJUSTMENTS	
DIAGNOSIS AND TESTING		CLOCKSPRING CENTERING	10
AIRBAG SYSTEM	3	SPECIAL TOOLS	
SERVICE PROCEDURES		STEERING WHEEL	11
AIRBAG SYSTEM	3		
CLEANUP PROCEDURE	4		

GENERAL INFORMATION

INTRODUCTION

A dual front airbag system is a standard equipment safety feature on this model. The system includes an inflatable airbag module in the center of the steering wheel, and a second inflatable airbag module in the instrument panel above the glove box. This system is designed to reduce serious injuries to the driver and front seat passenger during a frontal impact of the vehicle.

To test this passive restraint system, refer to the proper Diagnostic Procedures manual. If an airbag module assembly is defective and non-deployed, refer to the Chrysler Corporation current parts return list in the Warranty Policies and Procedures manual for the proper handling procedures.

Following are general descriptions of the major components in the airbag system. Refer to 8W-43 - Airbag System in Group 8W - Wiring Diagrams for complete circuit descriptions and diagrams.

WARNING:

- THE AIRBAG SYSTEM IS A SENSITIVE, COMPLEX ELECTROMECHANICAL UNIT. BEFORE ATTEMPTING TO DIAGNOSE OR SERVICE ANY AIRBAG SYSTEM OR RELATED STEERING WHEEL, STEERING COLUMN, OR INSTRUMENT PANEL COMPONENTS YOU MUST FIRST DISCONNECT AND ISOLATE THE BATTERY NEGATIVE (GROUND) CABLE. THEN WAIT TWO MINUTES FOR THE SYSTEM CAPACITOR TO DISCHARGE BEFORE FURTHER SYSTEM SERVICE. THIS IS THE ONLY SURE WAY TO DISABLE THE AIRBAG SYSTEM. FAILURE

TO DO THIS COULD RESULT IN ACCIDENTAL AIRBAG DEPLOYMENT AND POSSIBLE PERSONAL INJURY.

- THE AIRBAG MODULE INFLATOR ASSEMBLY CONTAINS SODIUM AZIDE AND POTASSIUM NITRATE. THESE MATERIALS ARE POISONOUS AND EXTREMELY FLAMMABLE. CONTACT WITH ACID, WATER, OR HEAVY METALS MAY PRODUCE HARMFUL AND IRRITATING GASES (SODIUM HYDROXIDE IS FORMED IN THE PRESENCE OF MOISTURE) OR COMBUSTIBLE COMPOUNDS. IN ADDITION, THE PASSENGER AIRBAG MODULE CONTAINS ARGON GAS PRESSURIZED TO OVER 2500 PSI. DO NOT ATTEMPT TO DISMANTLE AN AIRBAG MODULE OR TAMPER WITH ITS INFLATOR. DO NOT PUNCTURE, INCINERATE, OR BRING INTO CONTACT WITH ELECTRICITY. DO NOT STORE AT TEMPERATURES EXCEEDING 93° C (200° F).

- REPLACE AIRBAG SYSTEM COMPONENTS ONLY WITH PARTS SPECIFIED IN THE CHRYSLER MOPAR PARTS CATALOG. SUBSTITUTE PARTS MAY APPEAR INTERCHANGEABLE, BUT INTERNAL DIFFERENCES MAY RESULT IN INFERIOR OCCUPANT PROTECTION.

- THE FASTENERS, SCREWS, AND BOLTS ORIGINALLY USED FOR THE AIRBAG SYSTEM COMPONENTS HAVE SPECIAL COATINGS AND ARE SPECIFICALLY DESIGNED FOR THE AIRBAG SYSTEM. THEY MUST NEVER BE REPLACED WITH ANY SUBSTITUTES. ANY TIME A NEW FASTENER IS NEEDED, REPLACE IT WITH THE CORRECT FASTENERS PROVIDED IN THE SERVICE PACKAGE OR

GENERAL INFORMATION (Continued)

SPECIFIED IN THE CHRYSLER MOPAR PARTS CATALOG.

- **WHEN A STEERING COLUMN HAS AN AIRBAG MODULE ATTACHED, NEVER PLACE THE COLUMN ON THE FLOOR OR ANY OTHER SURFACE WITH THE STEERING WHEEL OR AIRBAG MODULE FACE DOWN.**

DESCRIPTION AND OPERATION

AIRBAG MODULE

DRIVER SIDE

The airbag module protective trim cover is the most visible part of the driver side airbag system. The module is mounted directly to the steering wheel. Located under the airbag module trim cover are the horn switch, the airbag cushion, and the airbag cushion supporting components. The airbag module includes a housing to which the cushion and inflator are attached and sealed. The airbag module cannot be repaired, and must be replaced if deployed or in any way damaged.

The inflator assembly is mounted to the back of the airbag module. The inflator seals the hole in the airbag cushion so it can discharge the gas it produces directly into the cushion when supplied with the proper electrical signal. The protective trim cover is fitted to the front of the airbag module and forms a decorative cover in the center of the steering wheel. Upon airbag deployment, the cover will split at a pre-determined breakout line.

PASSENGER SIDE

The instrument panel top pad is the most visible part of the passenger side airbag system. Located under the instrument panel top pad are the airbag cushion and its supporting components. The airbag module includes a housing to which the cushion and inflator are attached and sealed. The airbag module cannot be repaired, and must be replaced if deployed or in any way damaged.

The inflator assembly is mounted to the back of the airbag module. The inflator seals the hole in the airbag cushion so it can discharge the gas it produces directly into the cushion when supplied with the proper electrical signal. The instrument panel top pad above the glove box opening has a door and pre-determined breakout lines concealed beneath its decorative cover. Upon airbag deployment, the top pad will split at the breakout lines and the door will pivot out of the way.

The airbag module is secured to two mounting brackets beneath the instrument panel top pad and above the glove box opening. The airbag front mount-

ing bracket (closest to the dash panel) is welded to the instrument panel armature. The airbag rear mounting bracket (closest to the passenger) is bolted to the instrument panel armature. Following an airbag deployment, the airbag rear mounting bracket and the instrument panel top pad must be replaced. If the airbag front mounting bracket is damaged, the instrument panel armature assembly must also be replaced.

STORAGE

An airbag module must be stored in its original, special container until used for service. Also, it must be stored in a clean, dry environment; away from sources of extreme heat, sparks, and high electrical energy. Always place or store an airbag module on a surface with its trim cover or airbag side facing up, to minimize movement in case of an accidental deployment.

IMPACT SENSOR

The impact sensor provides verification of the direction and severity of an impact. One impact sensor is used. It is located inside the Airbag Control Module (ACM), which is secured to a bracket on the floor panel transmission tunnel inside the vehicle.

The impact sensor is an accelerometer that senses the rate of deceleration. The microprocessor in the ACM monitors the impact sensor signal. A pre-programmed decision algorithm in the microprocessor determines when the deceleration rate indicates an impact that is severe enough to require airbag system protection. When the programmed conditions are met, the ACM sends an electrical signal to deploy the airbag system components.

The impact sensor is calibrated for the specific vehicle. The sensor is only serviced as a unit with the ACM. The sensor cannot be repaired or adjusted and, if faulty or damaged, the ACM unit must be replaced.

CLOCKSPRING

The clockspring is mounted on the steering column behind the steering wheel. This assembly consists of a plastic housing which contains a flat, ribbon-like, electrically conductive tape that winds and unwinds with the steering wheel rotation.

The clockspring is used to maintain a continuous electrical circuit between the instrument panel wire harness and the driver side airbag module, the horn switch, the vehicle speed control switches, and the remote radio switches on vehicles that are so equipped.

The clockspring must be properly centered when it is installed on the steering column following any service removal, or it will be damaged. See the Clockspring Centering procedure in this group for more information.

DESCRIPTION AND OPERATION (Continued)

The clockspring cannot be repaired. If the clockspring is faulty, damaged, or if the airbag has been deployed, the clockspring must be replaced.

AIRBAG CONTROL MODULE

The Airbag Control Module (ACM) contains the impact sensor, and a microprocessor that monitors the impact sensor and the airbag system electrical circuits to determine the system readiness. The ACM contains On-Board Diagnostics (OBD), and will send an airbag lamp-on message to the instrument cluster on the Chrysler Collision Detection (CCD) data bus to light the airbag indicator lamp in the instrument cluster when a monitored airbag system fault occurs.

The ACM also contains an energy-storage capacitor. This capacitor stores enough electrical energy to deploy the airbags for up to one second following a battery disconnect or failure during an impact. The purpose of the capacitor is to provide airbag system protection in a severe secondary impact, if the initial impact has damaged or disconnected the battery, but was not severe enough to deploy the airbags.

The ACM cannot be repaired and, if damaged or faulty, it must be replaced.

DIAGNOSIS AND TESTING**AIRBAG SYSTEM**

A DRB scan tool is required for diagnosis of the airbag system. Refer to the proper Diagnostic Procedures manual for more information.

(1) Connect the DRB scan tool to the 16-way data link wire harness connector. The connector is located on the driver side lower edge of the instrument panel, outboard of the steering column (Fig. 1).

(2) Turn the ignition switch to the On position. Exit the vehicle with the DRB. Use the latest version of the proper DRB cartridge.

(3) Using the DRB, read and record the active Diagnostic Trouble Code (DTC) data.

(4) Read and record any stored DTC data.

(5) Refer to the proper Diagnostic Procedures manual if any DTC is found in Step 3 or Step 4.

(6) Erase the stored DTC data. If any problems remain, the stored DTC data will not erase.

(7) With the ignition switch still in the On position, make sure nobody is in the vehicle.

(8) From outside of the vehicle (away from the airbag modules in case of an accidental deployment) turn the ignition switch to the Off position for about ten seconds, and then back to the On position. Observe the airbag indicator lamp in the instrument cluster. It should light for six to eight seconds, and then go out. This indicates that the airbag system is functioning normally.

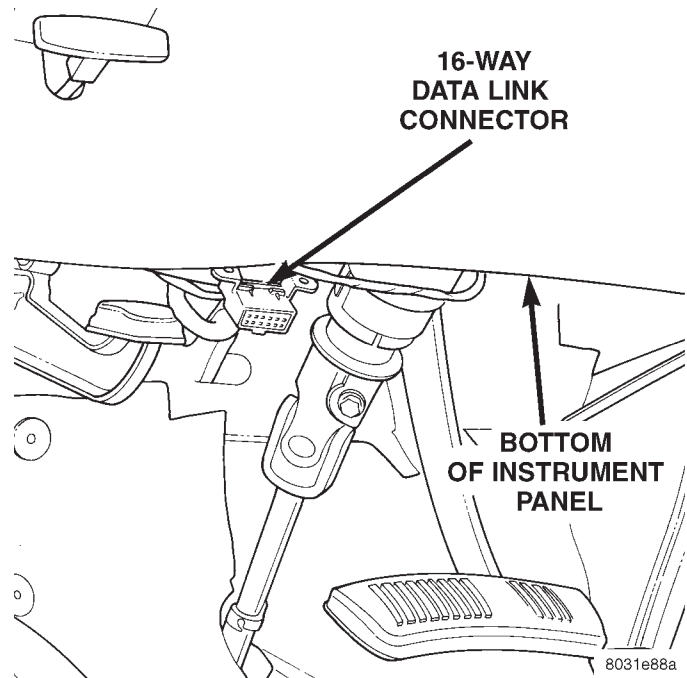


Fig. 1 16-Way Data Link Connector - Typical

NOTE: If the airbag indicator lamp fails to light, or lights and stays on, there is an airbag system malfunction. Refer to the proper Diagnostic Procedures manual to diagnose the problem.

SERVICE PROCEDURES**AIRBAG SYSTEM****NON-DEPLOYED**

At no time should any source of electricity be permitted near the inflator on the back of an airbag module. When carrying a non-deployed airbag module, the trim cover or airbag side of the module should be pointed away from the body to minimize injury in the event of an accidental deployment. If the module is placed on a bench or any other surface, the trim cover or airbag side of the module should be face up to minimize movement in the event of an accidental deployment.

In addition, the airbag system should be disarmed whenever any steering wheel, steering column, or instrument panel components require diagnosis or service. Failure to observe this warning could result in accidental airbag deployment and possible personal injury. Refer to Group 8E - Instrument Panel Systems for additional service procedures on the instrument panel. Refer to Group 19 - Steering for additional service procedures on the steering wheel and steering column.

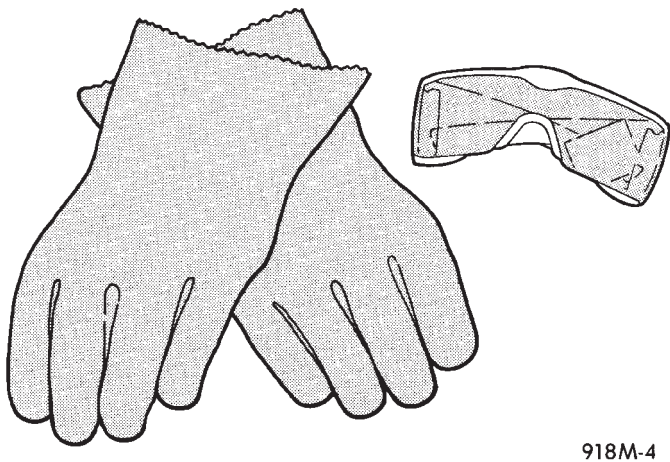
SERVICE PROCEDURES (Continued)**DEPLOYED**

Any vehicle which is to be returned to use after an airbag deployment, must have both airbag modules, the clockspring, the instrument panel top pad, and the passenger side airbag rear mounting bracket replaced. These components will be damaged or weakened as a result of an airbag deployment, which may or may not be obvious during a visual inspection, and are not intended for reuse.

Other vehicle components should be closely inspected, but are to be replaced only as required by the extent of the visible damage incurred.

CLEANUP PROCEDURE

Following an airbag system deployment, the vehicle interior will contain a powdery residue. This residue consists primarily of harmless particulate by-products of the small pyrotechnic charge used to initiate the airbag deployment propellant. However, this residue will also contain traces of sodium hydroxide powder, a chemical by-product of the propellant material that is used to generate the nitrogen gas that inflates the airbag. Since sodium hydroxide powder can irritate the skin, eyes, nose, or throat, be sure to wear safety glasses, rubber gloves, and a long-sleeved shirt during cleanup (Fig. 2).



918M-4

Fig. 2 Wear Safety Glasses and Rubber Gloves

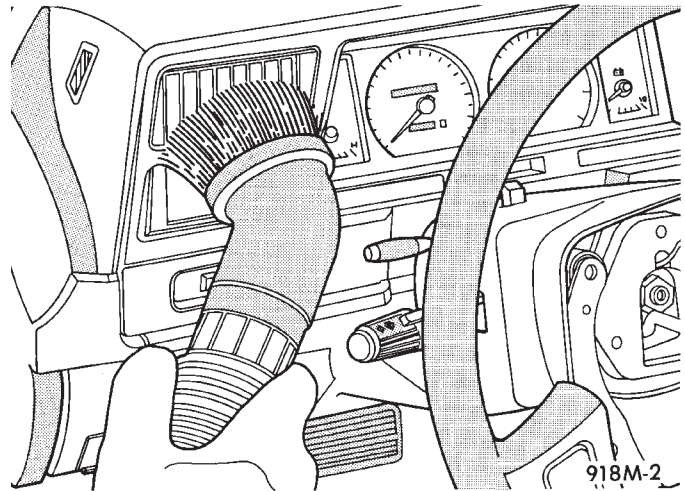
WARNING: IF YOU EXPERIENCE SKIN IRRITATION DURING CLEANUP, RUN COOL WATER OVER THE AFFECTED AREA. ALSO, IF YOU EXPERIENCE IRRITATION OF THE NOSE OR THROAT, EXIT THE VEHICLE FOR FRESH AIR UNTIL THE IRRITATION CEASES. IF IRRITATION CONTINUES, SEE A PHYSICIAN.

Begin the cleanup by removing the airbag modules from the vehicle as described in this group.

Use a vacuum cleaner to remove any residual powder from the vehicle interior. Clean from outside the

vehicle and work your way inside, so that you avoid kneeling or sitting on a non-cleaned area.

Be sure to vacuum the heater and air conditioning outlets as well (Fig. 3). Run the heater and air conditioning blower on the lowest speed setting and vacuum any powder expelled from the outlets. You may need to vacuum the interior of the vehicle a second time to recover all of the powder.



918M-2

Fig. 3 Vacuum Heater and A/C Outlets

Place the deployed airbag modules in your vehicular scrap pile.

REMOVAL AND INSTALLATION**AIRBAG MODULE****WARNING:**

- **THE AIRBAG SYSTEM IS A SENSITIVE, COMPLEX ELECTROMECHANICAL UNIT. BEFORE ATTEMPTING TO DIAGNOSE OR SERVICE ANY AIRBAG SYSTEM OR RELATED STEERING WHEEL, STEERING COLUMN, OR INSTRUMENT PANEL COMPONENTS YOU MUST FIRST DISCONNECT AND ISOLATE THE BATTERY NEGATIVE (GROUND) CABLE. THEN WAIT TWO MINUTES FOR THE SYSTEM CAPACITOR TO DISCHARGE BEFORE FURTHER SYSTEM SERVICE. THIS IS THE ONLY SURE WAY TO DISABLE THE AIRBAG SYSTEM. FAILURE TO DO THIS COULD RESULT IN ACCIDENTAL AIRBAG DEPLOYMENT AND POSSIBLE PERSONAL INJURY.**

- **WHEN REMOVING A DEPLOYED AIRBAG MODULE, RUBBER GLOVES, EYE PROTECTION, AND A LONG-SLEEVED SHIRT SHOULD BE WORN. THERE MAY BE DEPOSITS ON THE AIRBAG MODULE AND OTHER INTERIOR SURFACES. IN LARGE DOSES, THESE DEPOSITS MAY CAUSE IRRITATION TO THE SKIN AND EYES.**

REMOVAL AND INSTALLATION (Continued)

DRIVER SIDE

(1) Disconnect and isolate the battery negative cable. If the airbag has not been deployed, wait two minutes for the system capacitor to discharge before further service.

(2) From the underside of the steering wheel, remove the three screws that secure the driver side airbag module to the steering wheel (Fig. 4).

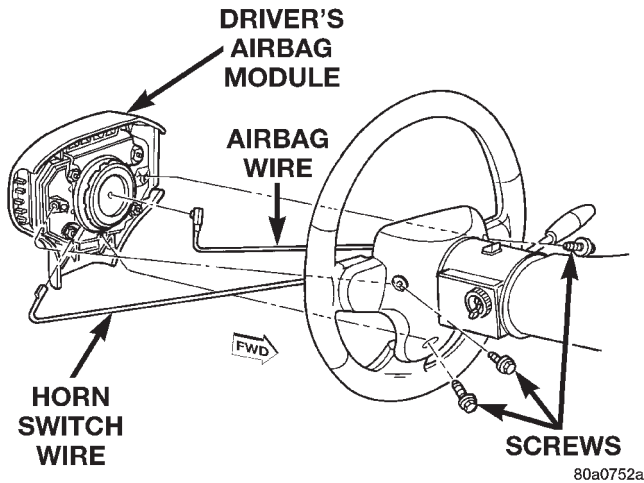


Fig. 4 Driver Side Airbag Module Remove/Install

(3) Pull the airbag module away from the steering wheel far enough to access the wire harness connectors on the back of the airbag module.

(4) Unplug the airbag module and horn switch wire harness connectors from the back of the airbag module.

(5) Remove the driver side airbag module from the vehicle.

(6) If the airbag has been deployed, the clockspring must be replaced. See Clockspring in this group for the procedures.

(7) When installing the airbag module, connect the clockspring wire harness connector to the module by pressing straight in on the connector. Be certain that the connector is fully engaged by observing the latch arms on each side of the connector. When these arms move outward from the connector, the connector is latched.

(8) Connect the horn switch wire harness connectors.

(9) Install the airbag module in the steering wheel. Tighten the mounting screws to 10.2 N·m (90 in. lbs.).

(10) Do not connect the battery negative cable at this time. See Airbag System in the Diagnosis and Testing section of this group for the proper procedures.

PASSENGER SIDE

The following procedure is for replacement of a faulty or damaged passenger side airbag module. If

the passenger side airbag has been deployed, the instrument panel top pad and passenger side airbag rear mounting bracket must be replaced. Refer to Group 8E - Instrument Panel Systems for the procedures required for instrument panel top pad service.

(1) Disconnect and isolate the battery negative cable. If the airbag has not been deployed, wait two minutes for the system capacitor to discharge before further service.

(2) Remove the instrument panel top pad. Refer to Instrument Panel Top Pad in Group 8E - Instrument Panel Systems for the procedures.

(3) Remove the screw that secures the upper airbag mounting bracket tab to the instrument panel base.

(4) Remove the two screws that secure the airbag module to the front airbag mounting bracket (Fig. 5).

PASSENGER'S AIRBAG MODULE

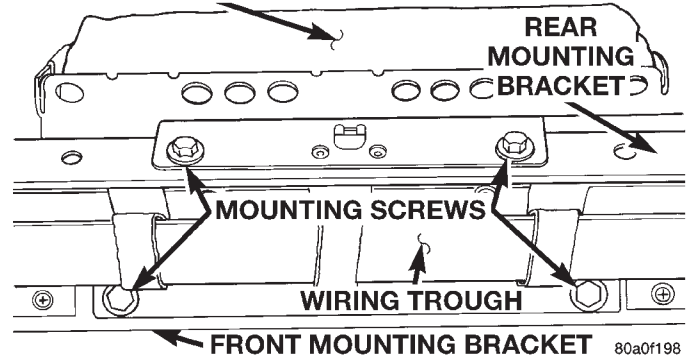


Fig. 5 Passenger Side Airbag Module Remove/Install

(5) Remove the two screws that secure the airbag module to the rear airbag mounting bracket.

(6) Unplug the airbag module wire harness connector and remove the airbag module from the instrument panel.

(7) If the airbag has been deployed, the passenger side rear airbag mounting bracket must be replaced. See Passenger Side Rear Airbag Mounting Bracket in this group for the procedures.

WARNING: USE EXTREME CARE TO PREVENT ANY FOREIGN MATERIAL FROM ENTERING THE PASSENGER SIDE AIRBAG MODULE, OR BECOMING ENTRAPPED BETWEEN THE INSTRUMENT PANEL TOP PAD AND THE PASSENGER SIDE AIRBAG MODULE. FAILURE TO OBSERVE THIS WARNING COULD RESULT IN OCCUPANT INJURIES UPON AIRBAG DEPLOYMENT.

(8) Install the passenger side airbag module in the instrument panel. Tighten the lower airbag module mounting screws to 11.75 N·m (105 in. lbs.). Tighten the upper airbag module mounting bracket tab screw to 2.2 N·m (20 in. lbs.).

REMOVAL AND INSTALLATION (Continued)

NOTE: If the lower airbag module mounting screws cannot be tightened to the specified torque value, replace the screws with the oversized screws specified in the Mopar Parts Catalog.

(9) When reinstalling the passenger side airbag module, be certain that the airbag module wire harness connector latches are fully engaged.

(10) Reverse the remaining removal procedures to complete the installation.

(11) Do not connect the battery negative cable at this time. See Airbag System in the Diagnosis and Testing section of this group for the proper procedures.

DRIVER SIDE AIRBAG TRIM COVER AND HORN SWITCH

WARNING:

- THE AIRBAG SYSTEM IS A SENSITIVE, COMPLEX ELECTROMECHANICAL UNIT. BEFORE ATTEMPTING TO DIAGNOSE OR SERVICE ANY AIRBAG SYSTEM OR RELATED STEERING WHEEL, STEERING COLUMN, OR INSTRUMENT PANEL COMPONENTS YOU MUST FIRST DISCONNECT AND ISOLATE THE BATTERY NEGATIVE (GROUND) CABLE. THEN WAIT TWO MINUTES FOR THE SYSTEM CAPACITOR TO DISCHARGE BEFORE FURTHER SYSTEM SERVICE. THIS IS THE ONLY SURE WAY TO DISABLE THE AIRBAG SYSTEM. FAILURE TO DO THIS COULD RESULT IN ACCIDENTAL AIRBAG DEPLOYMENT AND POSSIBLE PERSONAL INJURY.

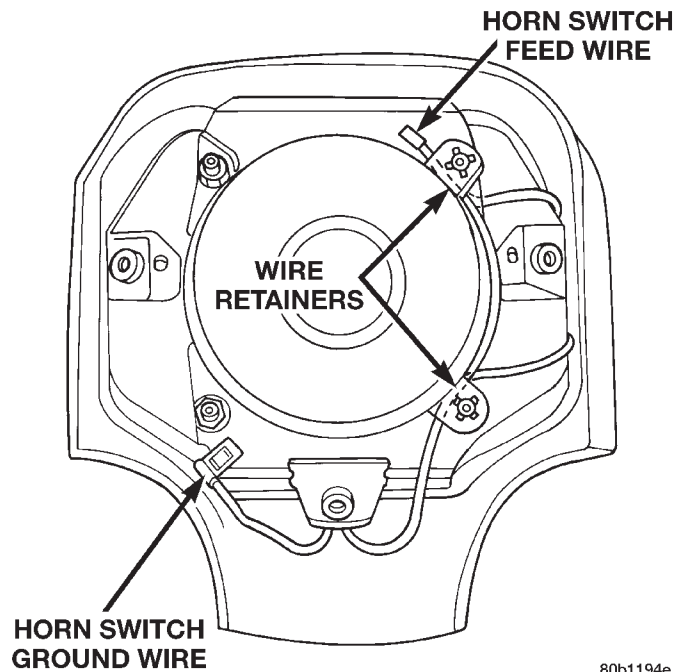
- THE HORN SWITCH IS INTEGRAL TO THE AIRBAG MODULE TRIM COVER. SERVICE OF THIS COMPONENT SHOULD BE PERFORMED ONLY BY CHRYSLER-TRAINED AND AUTHORIZED DEALER SERVICE TECHNICIANS. FAILURE TO TAKE THE PROPER PRECAUTIONS OR TO FOLLOW THE PROPER PROCEDURES COULD RESULT IN ACCIDENTAL, INCOMPLETE, OR IMPROPER AIRBAG DEPLOYMENT AND POSSIBLE PERSONAL INJURY.

(1) Disconnect and isolate the battery negative cable. If the airbag has not been deployed, wait two minutes for the system capacitor to discharge before further service.

(2) Remove the driver side airbag module from the steering wheel. See Airbag Module in this group for the procedures.

(3) Remove the plastic horn switch feed wire retainers from the studs on the airbag housing (Fig. 6).

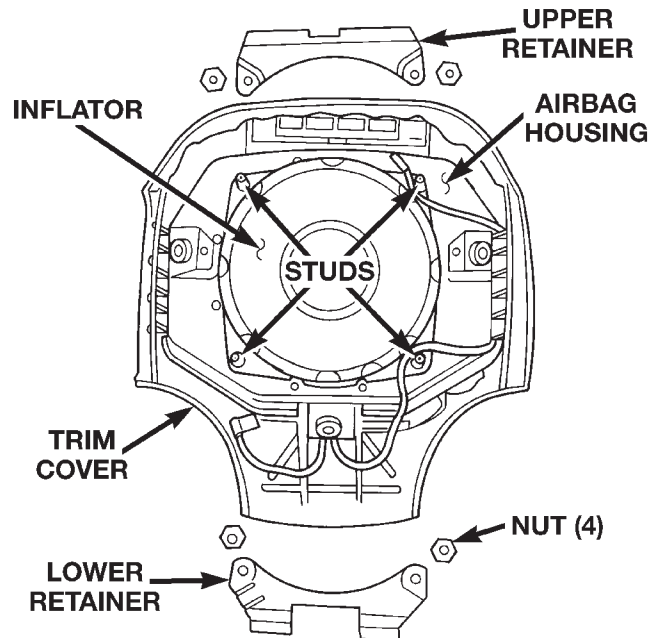
(4) Unplug the horn switch ground wire from the airbag module lower trim cover retainer.



80b1194e

Fig. 6 Horn Switch Feed Wires Remove/Install

(5) Remove the four nuts that secure the upper and lower trim cover retainers to the studs on the airbag housing (Fig. 7).



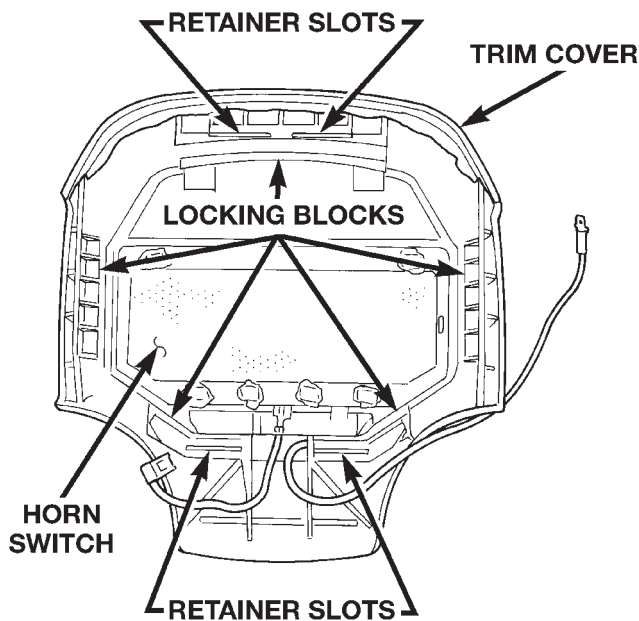
80b1194f

Fig. 7 Airbag Trim Cover Retainers Remove/Install

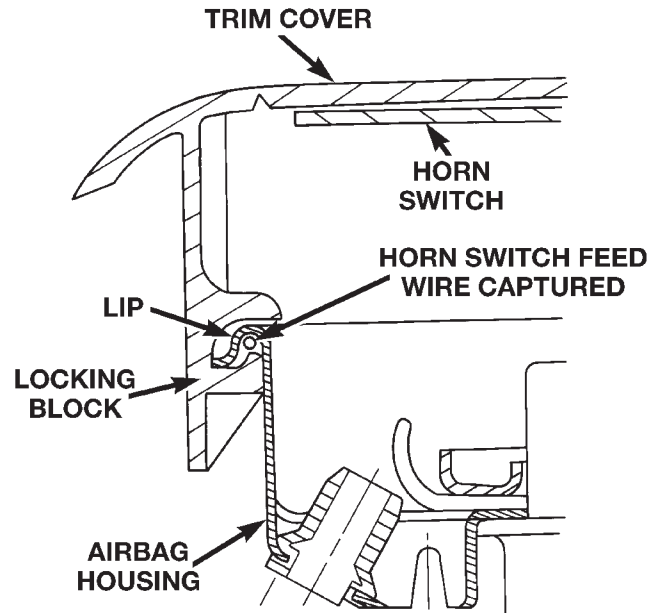
(6) Remove the upper and lower trim cover retainers from the airbag housing studs.

(7) Disengage the five trim cover locking blocks from the lip around the outside edge of the airbag housing and remove the housing from the cover (Fig. 8).

REMOVAL AND INSTALLATION (Continued)



80a0f19e



80b11950

Fig. 8 Airbag Trim Cover Remove/Install

WARNING: USE EXTREME CARE TO PREVENT ANY FOREIGN MATERIAL FROM ENTERING THE DRIVER SIDE AIRBAG MODULE, OR BECOMING ENTRAPPED BETWEEN THE DRIVER SIDE AIRBAG MODULE TRIM COVER AND THE DRIVER SIDE AIRBAG MODULE. FAILURE TO OBSERVE THIS WARNING COULD RESULT IN OCCUPANT INJURIES UPON AIRBAG DEPLOYMENT.

(8) When installing the trim cover and horn switch, be certain that the locking blocks are fully engaged on the lip of the airbag housing and that the horn switch feed wire is captured between the lip of the airbag housing and the locking block (Fig. 9).

(9) When installing the upper and lower trim cover retainers, be certain that the tabs on each retainer are engaged in the retainer slots of the trim cover (Fig. 8).

(10) Install and tighten the trim cover retainer nuts to 10 N·m (90 in. lbs.).

(11) Reverse the remaining removal procedures to complete the installation, but do not connect the battery negative cable at this time. See Airbag System in the Diagnosis and Testing section of this group for the proper procedures.

PASSENGER SIDE AIRBAG REAR MOUNTING BRACKET

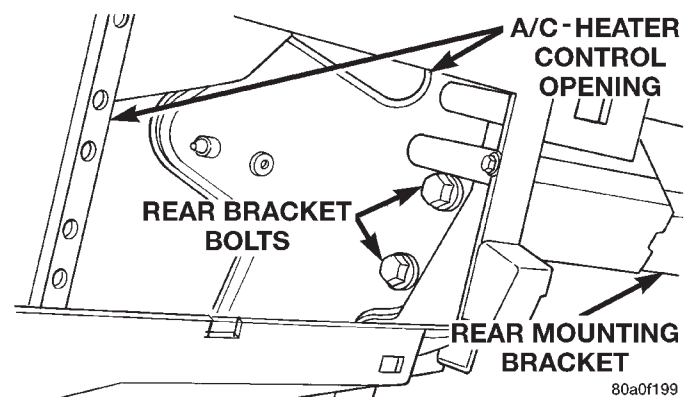
(1) Remove the passenger side airbag module from the instrument panel. See Airbag Module in this group for the procedures.

Fig. 9 Airbag Trim Cover Locking Blocks Installed

(2) Remove the screws that secure the instrument panel wire harness trough to the airbag rear mounting bracket.

(3) Remove the heater and air conditioner control from the instrument panel. Refer to Heater-A/C Control in Group 24 - Heating and Air Conditioning for the procedures.

(4) Reach through the heater-A/C control opening in the instrument panel to remove the two bolts that secure the inboard end of the airbag rear mounting bracket to the instrument panel armature (Fig. 10).



80a0f199

Fig. 10 Inboard Mounting Bolts Remove/Install

(5) Remove the two bolts that secure the outboard end of the airbag rear mounting bracket from the passenger side outboard end of the instrument panel armature (Fig. 11).

(6) Remove the airbag rear mounting bracket through the lower opening of the instrument panel armature, outboard end first.

REMOVAL AND INSTALLATION (Continued)

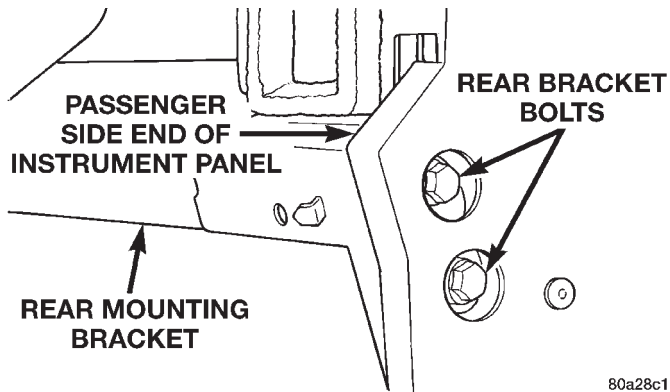


Fig. 11 Outboard Mounting Bolts Remove/Install

(7) Reverse the removal procedures to install. Tighten the bracket mounting bolts to 11.75 N·m (105 in. lbs.). Tighten the wire harness trough screws to 2.2 N·m (20 in. lbs.).

AIRBAG CONTROL MODULE

WARNING:

- **THE AIRBAG CONTROL MODULE CONTAINS THE IMPACT SENSOR, WHICH ENABLES THE SYSTEM TO DEPLOY THE AIRBAG. BEFORE ATTEMPTING TO DIAGNOSE OR SERVICE ANY AIRBAG SYSTEM OR RELATED STEERING WHEEL, STEERING COLUMN, OR INSTRUMENT PANEL COMPONENTS YOU MUST FIRST DISCONNECT AND ISOLATE THE BATTERY NEGATIVE (GROUND) CABLE. THEN WAIT TWO MINUTES FOR THE SYSTEM CAPACITOR TO DISCHARGE BEFORE FURTHER SYSTEM SERVICE. THIS IS THE ONLY SURE WAY TO DISABLE THE AIRBAG SYSTEM. FAILURE TO DO THIS COULD RESULT IN ACCIDENTAL AIRBAG DEPLOYMENT AND POSSIBLE PERSONAL INJURY.**

- **NEVER STRIKE OR KICK THE AIRBAG CONTROL MODULE, AS IT CAN DAMAGE THE IMPACT SENSOR OR AFFECT ITS CALIBRATION. IF AN AIRBAG CONTROL MODULE IS ACCIDENTALLY DROPPED DURING SERVICE, THE MODULE MUST BE SCRAPPED AND REPLACED WITH A NEW UNIT.**

(1) Disconnect and isolate the battery negative cable. If the airbag has not been deployed, wait two minutes for the system capacitor to discharge before further service.

(2) Pull the transmission shift lever handle straight up firmly and quickly to remove the handle.

(3) Using a trim stick or another suitable wide flat-bladed tool, pry gently between the edge of the transmission shift indicator bezel and the floor console to release the snap clip retainers (Fig. 12).

(4) Raise the shift indicator bezel far enough from the console to remove the lamp sockets from the bezel, then remove the bezel from the console.

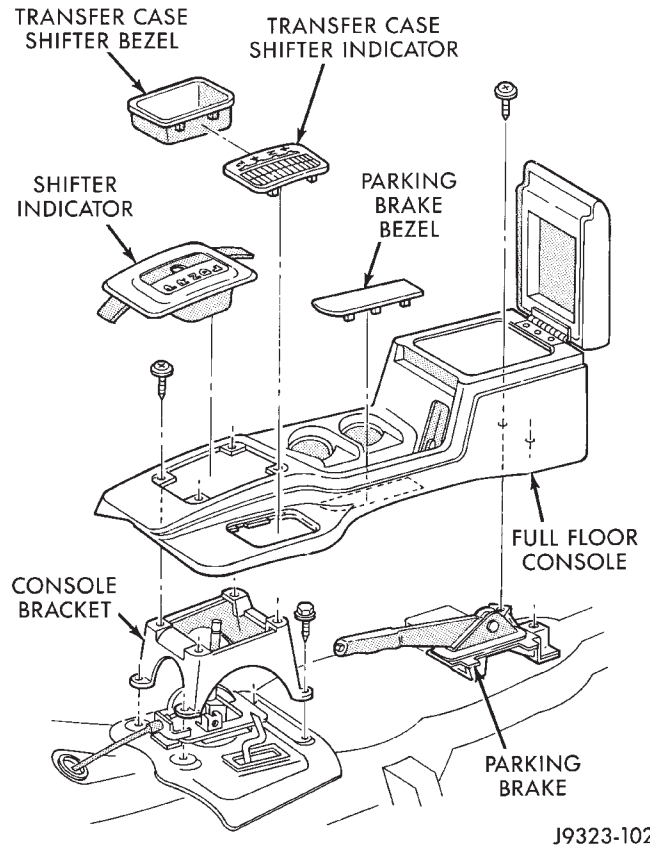


Fig. 12 Floor Console Components

(5) Remove the screws that secure the floor console to the console and parking brake lever mounting brackets.

(6) Remove the floor console from the floor pan transmission tunnel.

(7) Unplug the Airbag Control Module (ACM) wire harness connector. To unplug the wire harness connector from the ACM (Fig. 13):

- Pull the two white locks out about 3 mm (0.125 in.) from each side of the connector.
- Squeeze the two connector latch tabs between the thumb and forefinger.
- Pull the connector out of the ACM receptacle.

NOTE: Always remove and replace the airbag control module and its mounting bracket as a unit. Replacement modules include a replacement mounting bracket. Do not transfer the module to another mounting bracket.

(8) Remove the four screws that secure the ACM mounting bracket to the floor pan transmission tunnel (Fig. 14).

(9) Remove the ACM and mounting bracket from the vehicle as a unit.

(10) When installing the ACM, position the unit with the arrow on the ACM housing pointing forward.

REMOVAL AND INSTALLATION (Continued)

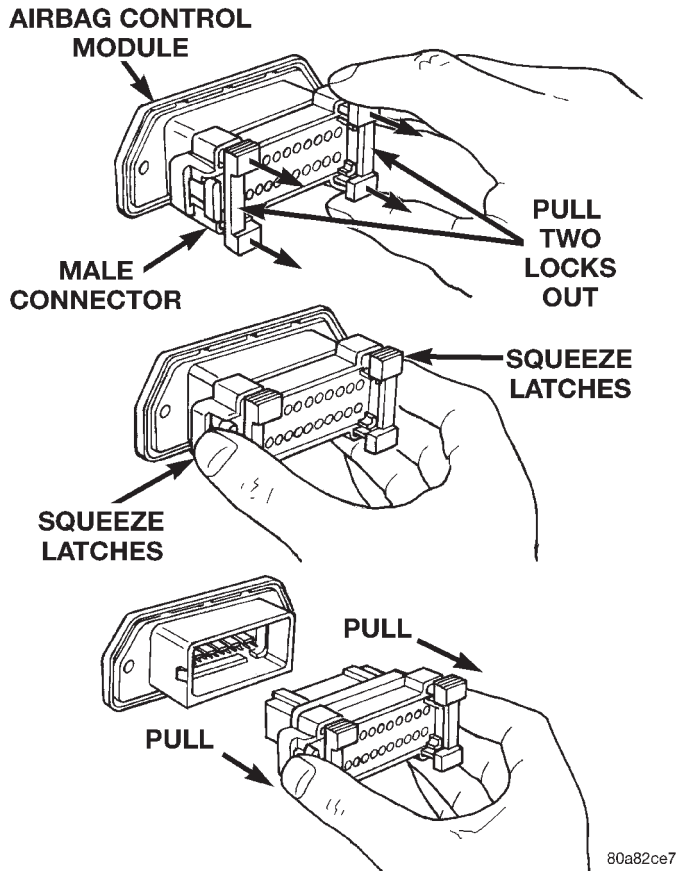


Fig. 13 Airbag Control Module Connector Removal

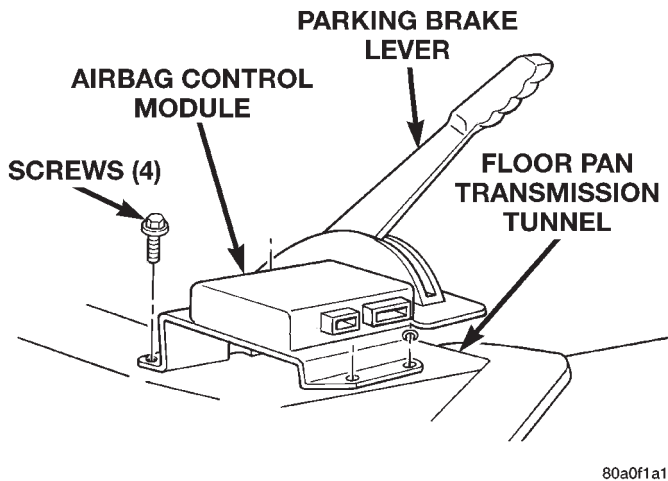


Fig. 14 Airbag Control Module Remove/Install

(11) Attach the ACM to the floor pan transmission tunnel with the four mounting screws. Tighten the mounting screws to 10.7 N·m (95 in. lbs.).

(12) Plug in the wire harness connector to the ACM. Be certain that the connector latches are fully engaged and that the connector locks are pushed in.

(13) Reverse the remaining removal procedures to complete the installation.

(14) Do not connect the battery negative cable at this time. See Airbag System in the Diagnosis and

Testing section of this group for the proper procedures.

CLOCKSPRING

WARNING: THE AIRBAG SYSTEM IS A SENSITIVE, COMPLEX ELECTROMECHANICAL UNIT. BEFORE ATTEMPTING TO DIAGNOSE OR SERVICE ANY AIRBAG SYSTEM OR RELATED STEERING WHEEL, STEERING COLUMN, OR INSTRUMENT PANEL COMPONENTS YOU MUST FIRST DISCONNECT AND ISOLATE THE BATTERY NEGATIVE (GROUND) CABLE. THEN WAIT TWO MINUTES FOR THE SYSTEM CAPACITOR TO DISCHARGE BEFORE FURTHER SYSTEM SERVICE. THIS IS THE ONLY SURE WAY TO DISABLE THE AIRBAG SYSTEM. FAILURE TO DO THIS COULD RESULT IN ACCIDENTAL AIRBAG DEPLOYMENT AND POSSIBLE PERSONAL INJURY.

(1) Turn the steering wheel until the front wheels are in the straight-ahead position before starting the procedure.

(2) Disconnect and isolate the battery negative cable. If the airbag has not been deployed, wait two minutes for the system capacitor to discharge before further service.

(3) Remove the driver side airbag module from the steering wheel. See Airbag Module in this group for the procedures.

(4) If the vehicle is so equipped, unplug the vehicle speed control switch and the remote radio switch wire harness connectors in the steering wheel.

(5) Remove the nut that secures the steering wheel to the steering column upper shaft.

(6) Remove the steering wheel with a steering wheel puller (Special Tool C-3428-B).

(7) Remove the upper and lower steering column shrouds to gain access to the clockspring wire harness connectors (Fig. 15).

(8) Unplug the wire harness connectors from the clockspring.

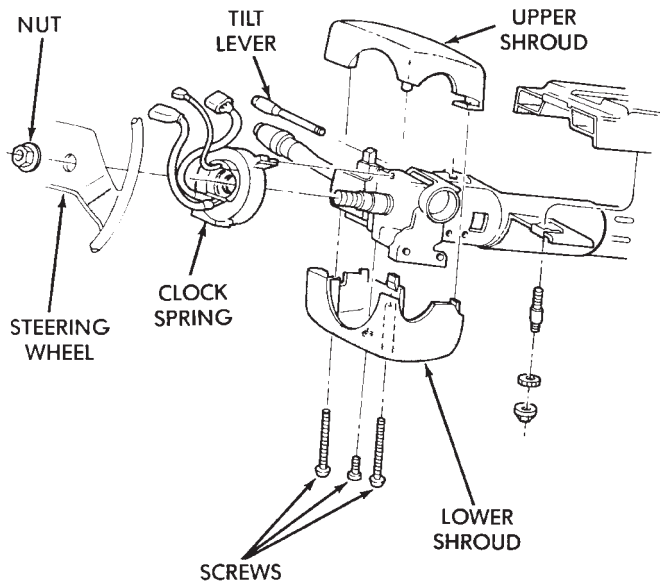
(9) Remove the lower fixed column shroud.

(10) Unplug the wire harness connector between the clockspring and the instrument panel wire harness, located near the base of the steering column.

(11) To remove the clockspring, carefully lift the locating fingers of the clockspring assembly from the steering column as necessary. The clockspring cannot be repaired. It must be replaced if faulty or damaged, or if the airbag has been deployed.

(12) When installing the clockspring, snap the clockspring onto the steering column. If the clockspring is not positioned properly in relation to the steering wheel, see Clockspring Centering in this group before installing the steering wheel.

REMOVAL AND INSTALLATION (Continued)



J938J-5

Fig. 15 Steering Column Shrouds Remove/Install - Typical

(13) Plug the clockspring wire harness connector into the instrument panel wire harness. Be certain that the wire harness locator clips are properly seated on the outside of the wiring trough and that the wire harness connector latches are fully engaged.

(14) Reinstall the steering column shrouds. Be certain that the clockspring wire harness is inside the shrouds.

(15) The front wheels should still be in the straight-ahead position. Install the steering wheel being certain to index the flats on the hub of the steering wheel with the formations on the inside of the clockspring. Pull the wire harnesses from the clockspring through the upper and lower holes in the steering wheel hub. Tighten the steering wheel nut to 61 N·m (45 ft. lbs.). Be certain not to pinch the wiring between the steering wheel and the nut.

(16) If the vehicle is so equipped, plug in the vehicle speed control switch and remote radio switch wire harness connectors.

(17) Install the driver side airbag module onto the steering wheel. See Airbag Module in this group for the procedures.

ADJUSTMENTS

CLOCKSPRING CENTERING

If the rotating tape within the clockspring is not positioned properly in relation to the steering wheel and the front wheels, the clockspring may fail during use. The clockspring must be centered if it is not

known to be properly positioned, or if the front wheels were moved from the straight-ahead position with the clockspring removed during any service procedure.

WARNING: THE AIRBAG SYSTEM IS A SENSITIVE, COMPLEX ELECTROMECHANICAL UNIT. BEFORE ATTEMPTING TO DIAGNOSE OR SERVICE ANY AIRBAG SYSTEM OR RELATED STEERING WHEEL, STEERING COLUMN, OR INSTRUMENT PANEL COMPONENTS YOU MUST FIRST DISCONNECT AND ISOLATE THE BATTERY NEGATIVE (GROUND) CABLE. THEN WAIT TWO MINUTES FOR THE SYSTEM CAPACITOR TO DISCHARGE BEFORE FURTHER SYSTEM SERVICE. THIS IS THE ONLY SURE WAY TO DISABLE THE AIRBAG SYSTEM. FAILURE TO DO THIS COULD RESULT IN ACCIDENTAL AIRBAG DEPLOYMENT AND POSSIBLE PERSONAL INJURY.

(1) Turn the steering wheel until the front wheels are in the straight-ahead position before starting the centering procedure.

(2) Disconnect and isolate the battery negative cable. If the airbag has not been deployed, wait two minutes for the system capacitor to discharge before further service.

(3) Remove the driver side airbag module from the steering wheel. See Airbag Module in this group for the procedures.

(4) If the vehicle is so equipped, unplug the vehicle speed control switch and the remote radio switch wire harness connectors in the steering wheel.

(5) Remove the nut that secures the steering wheel to the steering column upper shaft.

(6) Remove the steering wheel with a steering wheel puller (Special Tool C-3428-B).

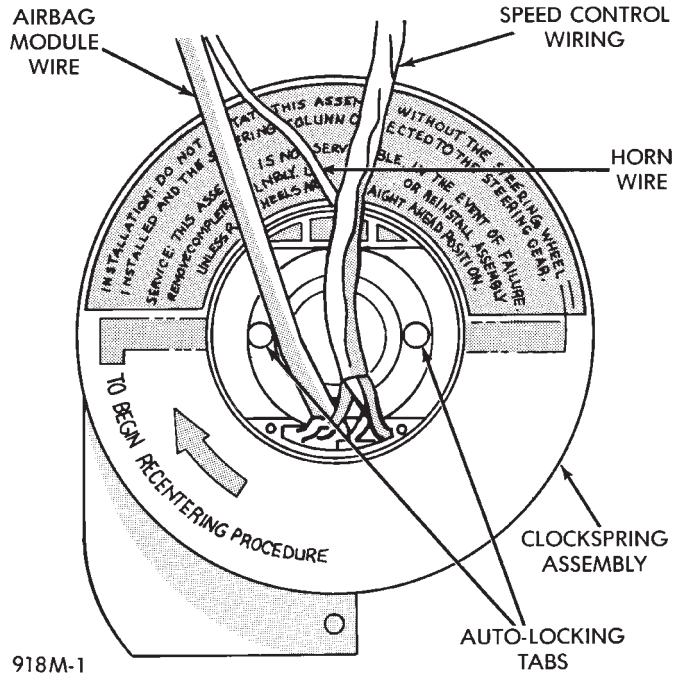
(7) Depress the two plastic clockspring auto-locking tabs (Fig. 16).

(8) Keeping the locking mechanism disengaged, rotate the clockspring rotor clockwise to the end of its travel. **Do not apply excessive torque.**

(9) From the end of the clockwise travel, rotate the rotor about two and one-half turns counterclockwise. The horn wire harness should end up at the top, and the airbag wire harness at the bottom.

(10) The front wheels should still be in the straight-ahead position. Install the steering wheel being certain to index the flats on the hub of the steering wheel with the formations on the inside of the clockspring. Pull the wire harnesses from the clockspring through the upper and lower holes in the steering wheel hub. Tighten the steering wheel nut to 61 N·m (45 ft. lbs.). Be certain not to pinch any of the wiring between the steering wheel and the nut.

ADJUSTMENTS (Continued)



918M-1

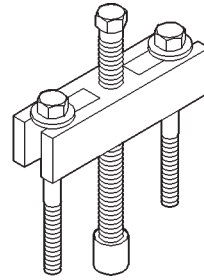
Fig. 16 Clockspring Auto-Locking Tabs

(11) If the vehicle is so equipped, plug in the vehicle speed control switch and remote radio switch wire harness connectors.

(12) Install the airbag module onto the steering wheel. See Airbag Module in this group for the procedures.

SPECIAL TOOLS

STEERING WHEEL



Puller C-3428-B

ELECTRICALLY HEATED SYSTEMS

CONTENTS

	page		page
DEFOGGER SYSTEM	1	HEATED SEATS	7

DEFOGGER SYSTEM

INDEX

	page		page
GENERAL INFORMATION		DEFOGGER SWITCH	4
INTRODUCTION	1	REAR GLASS HEATING GRID	3
DESCRIPTION AND OPERATION		REAR WINDOW DEFOGGER SYSTEM	3
BODY CONTROL MODULE	2	SERVICE PROCEDURES	
DEFOGGER RELAY	2	REAR GLASS HEATING GRID REPAIR	5
DEFOGGER SWITCH	2	REMOVAL AND INSTALLATION	
OUTSIDE MIRROR HEATING GRID	2	DEFOGGER RELAY	6
REAR GLASS HEATING GRID	1	DEFOGGER SWITCH	6
DIAGNOSIS AND TESTING			
DEFOGGER RELAY	4		

GENERAL INFORMATION

INTRODUCTION

An electrically heated rear window defogger and electrically heated outside rear view mirrors are standard factory-installed equipment on this model. The defogger will only operate when the ignition switch is in the On position. When the defogger switch is in the On position, electric heater grids on the rear window glass and behind the outside rear view mirror glass are energized. These grids produce heat to help clear the rear window glass and outside rear view mirrors of ice, snow, or fog.

This defogger system is controlled by a switch located inboard of the steering column in the inboard switch pod on the instrument panel. A Light-Emitting Diode (LED) above the switch button in the switch pod will light to indicate when the defogger system is turned on. The Body Control Module (BCM), which contains the defogger system timer logic, monitors the state of the defogger switch through a hard-wired input. The BCM circuitry controls the defogger system through a hard-wired control output to the defogger relay.

The defogger system will be automatically turned off after a programmed time interval of about ten

minutes. After the initial timed interval has expired, if the defogger switch is turned on again during the same ignition cycle, the defogger system will automatically turn off after about five minutes.

The defogger system will automatically shut off if the ignition switch is turned to the Off position, or it can be turned off manually by depressing the instrument panel switch. Refer to the owner's manual for more information on the defogger system controls and operation.

Following are general descriptions of the major components in the defogger system. Refer to 8W-48 - Rear Window Defogger and 8W-62 - Power Mirrors in Group 8W - Wiring Diagrams for complete circuit descriptions and diagrams.

DESCRIPTION AND OPERATION

REAR GLASS HEATING GRID

The heated rear window glass has two electrically conductive vertical bus bars and a series of horizontal grid lines made of a silver-ceramic material, which is baked on and bonded to the inside surface of the glass. The grid lines and bus bars comprise a parallel electrical circuit.

DESCRIPTION AND OPERATION (Continued)

When the rear window defogger switch is placed in the On position, electrical current is directed to the rear window grid lines through the bus bars. The grid lines heat the rear window to clear the surface of fog or snow. Protection for the heated grid circuit is provided by a fuse in the junction block.

The grid lines and bus bars are highly resistant to abrasion. However, it is possible for an open circuit to occur in an individual grid line, resulting in no current flow through the line.

The grid lines can be damaged or scraped off with sharp instruments. Care should be taken when cleaning the glass or removing foreign materials, decals, or stickers from the glass. Normal glass cleaning solvents or hot water used with rags or toweling is recommended.

A repair kit is available to repair the grid lines and bus bars, or to reinstall the heated glass spade terminals.

OUTSIDE MIRROR HEATING GRID

Vehicles equipped with the optional heated mirror package have an electric heating grid located behind the mirror glass of each outside rear view mirror. The heated mirrors are controlled by the rear window defogger switch. Electrical current is directed to the heating grid inside the mirror only when the rear window defogger switch is in the On position.

If the outside mirror heating grids and rear window heating grid are both inoperative, diagnosis of the rear window defogger system should be performed as described in this group. If the outside mirror heating grids are inoperative, but the rear window heating grid is operating as designed, refer to Group 8T - Power Mirror Systems for the diagnosis of the mirror.

The heating grid behind each outside mirror glass cannot be repaired and, if faulty or damaged, the entire mirror unit must be replaced. Refer to Group 8T - Power Mirror Systems for the power mirror service procedures.

DEFOGGER SWITCH

The rear window defogger switch is mounted in the inboard instrument panel switch pod, inboard of the steering column. The momentary-type switch provides a hard-wired ground signal to the Body Control Module (BCM) each time it is depressed. The BCM rear window defogger timer and logic circuitry responds by energizing or de-energizing the rear window defogger relay.

Energizing the rear window defogger relay provides electrical current to the rear window defogger grid and the Light-Emitting Diode (LED) indicator in the switch, which lights to indicate when the defogger system is turned On. The defogger switch and

LED cannot be repaired and, if faulty, the inboard switch pod unit must be replaced.

DEFOGGER RELAY

The rear window defogger relay is a International Standards Organization (ISO)-type relay. The rear window defogger relay is a electromechanical device that switches fused battery current to the rear glass heating grid and the Light-Emitting Diode (LED) indicator of the defogger switch, when the Body Control Module (BCM) rear window defogger timer and logic circuitry grounds the relay coil. See the Diagnosis and Testing section of this group for more information on the operation of the rear window defogger relay.

The rear window defogger relay is located in the junction block, on the right cowl side inner panel below the instrument panel in the passenger compartment.

The rear window defogger relay cannot be repaired and, if faulty or damaged, it must be replaced.

BODY CONTROL MODULE

A Body Control Module (BCM) is used on this model to control and integrate many of the electronic functions and features included on the vehicle. The BCM contains a central processing unit and interfaces with other modules in the vehicle on the Chrysler Collision Detection (CCD) data bus network.

The CCD data bus network allows the sharing of sensor information. This helps to reduce wire harness complexity, reduce internal controller hardware, and reduce component sensor current loads. At the same time, this system provides increased reliability, enhanced diagnostics, and allows the addition of many new feature capabilities.

One of the systems that the BCM supports and controls, is the rear window defogger system. In its role as the defogger system timer and controller, the BCM receives hard-wired inputs from the defogger switch and the ignition switch. The programming in the BCM allows it to process the information from these inputs and send a control output to energize or de-energize the defogger relay. The BCM also sends a defogger switch status message to the Driver Door Module (DDM) and Passenger Door Module (PDM) on the CCD data bus. The DDM and PDM respond by controlling the current feeds to their respective outside rear view mirror heating elements.

The BCM is mounted under the driver side outboard end of the instrument panel, behind the instrument panel support armature and below the outboard switch pod. Refer to Group 8E - Instrument Panel Systems for the removal and installation procedures. For diagnosis of the BCM or the CCD data bus, the use of a DRB scan tool and the proper Diag-

DESCRIPTION AND OPERATION (Continued)

nostic Procedures manual are recommended. The BCM can only be serviced by an authorized electronic repair station. Refer to the latest Warranty Policies and Procedures manual for a current listing of authorized electronic repair stations.

DIAGNOSIS AND TESTING**REAR WINDOW DEFOGGER SYSTEM**

For circuit descriptions and diagrams, refer to 8W-48 - Rear Window Defogger in Group 8W - Wiring Diagrams. The operation of the electrically heated rear window defogger system can be confirmed in one of the following manners:

1. Turn the ignition switch to the On position. While monitoring the instrument panel voltmeter, set the defogger switch in the On position. When the defogger switch is turned On, a distinct voltmeter needle deflection should be noted.

2. Turn the ignition switch to the On position. Set the defogger switch in the On position. The rear window defogger operation can be checked by feeling the rear window or outside rear view mirror glass. A distinct difference in temperature between the grid lines and the adjacent clear glass or the mirror glass can be detected within three to four minutes of operation.

3. Using a 12-volt DC voltmeter, contact the rear glass heating grid terminal A (right side) with the negative lead, and terminal B (left side) with the positive lead (Fig. 1). The voltmeter should read battery voltage.

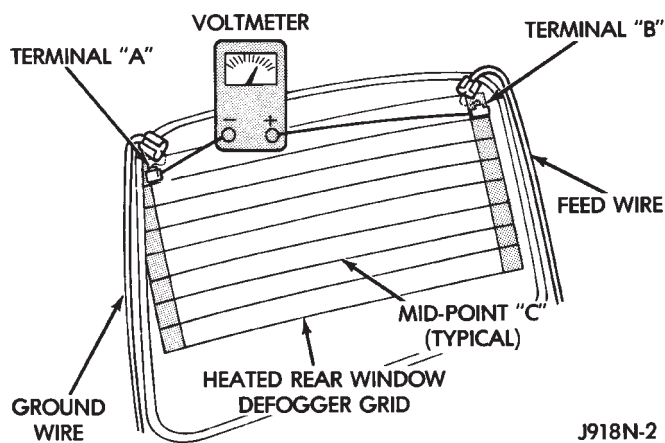


Fig. 1 Rear Window Glass Grid Test

The above checks will confirm system operation. Illumination of the defogger switch LED means that there is electrical current available at the output of the defogger relay, but does not confirm that the electrical current is reaching the rear glass heating grid lines.

If the defogger system does not operate, the problem should be isolated in the following manner:

(1) Confirm that the ignition switch is in the On position.

(2) Ensure that the rear glass heating grid feed and ground wires are connected to the glass. Confirm that the ground wire has continuity to ground.

(3) Check the fuses in the Power Distribution Center (PDC) and in the junction block. The fuses must be tight in their receptacles and all electrical connections must be secure.

When the above steps have been completed and the rear glass heating grid is still inoperative, one or more of the following is faulty:

- Defogger switch
- Defogger relay
- Body Control Module (BCM)
- Rear window grid lines (all grid lines would have to be broken or one of the feed wires disconnected for the entire system to be inoperative).

When the above steps have been completed and the heated mirror glass heating element is still inoperative, one or more of the following is faulty:

- Body Control Module (BCM)
- Chrysler Collision Detection (CCD) data bus
- Driver or passenger door module
- Outside rear view mirror heating elements.

If setting the defogger switch to the On position produces a severe voltmeter deflection, check for a short circuit between the defogger relay output and the rear glass heating grid.

REAR GLASS HEATING GRID

For circuit descriptions and diagrams, refer to 8W-48 - Rear Window Defogger in Group 8W - Wiring Diagrams. To detect breaks in the grid lines, the following procedure is required:

(1) Turn the ignition switch to the On position. Set the defogger switch in the On position. The indicator lamp should light. If OK, go to Step 2. If not OK, see the Defogger Relay diagnosis in this group.

(2) Using a 12-volt DC voltmeter, contact the vertical bus bar on the right side of the vehicle with the negative lead. With the positive lead, contact the vertical bus bar on the left side of the vehicle. The voltmeter should read battery voltage. If OK, go to Step 3. If not OK, repair the open circuit to the defogger relay as required.

(3) With the negative lead of the voltmeter, contact a good body ground point. The voltage reading should not change. If OK, go to Step 4. If not OK, repair the circuit to ground as required.

(4) Connect the negative lead of the voltmeter to the right side bus bar and touch each grid line at midpoint C with the positive lead. A reading of approximately six volts indicates a line is good. A reading of zero volts indicates a break in the grid line between midpoint C and the left side bus bar. A

DIAGNOSIS AND TESTING (Continued)

reading of ten to fourteen volts indicates a break between midpoint C and the right side bus bar. Move the positive lead on the grid line towards the break and the voltage reading will change as soon as the break is crossed.

DEFOGGER SWITCH

For circuit descriptions and diagrams, refer to 8W-48 - Rear Window Defogger in Group 8W - Wiring Diagrams.

WARNING: ON VEHICLES EQUIPPED WITH AIR-BAGS, REFER TO GROUP 8M - PASSIVE RESTRAINT SYSTEMS BEFORE ATTEMPTING ANY STEERING WHEEL, STEERING COLUMN, OR INSTRUMENT PANEL COMPONENT DIAGNOSIS OR SERVICE. FAILURE TO TAKE THE PROPER PRECAUTIONS COULD RESULT IN ACCIDENTAL AIR-BAG DEPLOYMENT AND POSSIBLE PERSONAL INJURY.

(1) Disconnect and isolate the battery negative cable. Remove the inboard instrument panel switch pod and unplug the switch pod 10-way wire harness connector.

(2) Check for continuity between the ground circuit cavity of the switch pod 10-way wire harness connector and a good ground. There should be continuity. If OK, go to Step 3. If not OK, repair the open circuit as required.

(3) Connect two jumper wires to the inboard switch pod. Connect one jumper from the ground circuit terminal in the 10-way wire harness connector receptacle on the back of the inboard switch pod housing to a good ground. Connect the other jumper from the fused rear window defogger relay output circuit terminal of the 10-way wire harness connector receptacle to a 12-volt battery feed. The defogger switch LED indicator should light. If OK, go to Step 4. If not OK, replace the faulty inboard switch pod.

(4) Check for continuity between the ground circuit terminals of the 10-way wire harness connector receptacle on the back of the inboard switch pod housing. There should be momentary continuity as the defogger switch button is depressed, and then no continuity. If OK, go to Step 5. If not OK, replace the faulty inboard switch pod.

(5) Unplug the white 24-way wire harness connector from the Body Control Module (BCM). Check for continuity between the rear window defogger switch sense circuit cavity of the inboard switch pod 10-way wire harness connector and a good ground. There should be no continuity. If OK, go to Step 6. If not OK, repair the short circuit as required.

(6) Check for continuity between the rear window defogger switch sense circuit cavities of the inboard

switch pod 10-way wire harness connector and the BCM white 24-way wire harness connector. There should be continuity. If OK, see the Defogger Relay diagnosis in this group. If not OK, repair the open circuit as required.

DEFOGGER RELAY

WARNING: ON VEHICLES EQUIPPED WITH AIR-BAGS, REFER TO GROUP 8M - PASSIVE RESTRAINT SYSTEMS BEFORE ATTEMPTING ANY STEERING WHEEL, STEERING COLUMN, OR INSTRUMENT PANEL COMPONENT DIAGNOSIS OR SERVICE. FAILURE TO TAKE THE PROPER PRECAUTIONS COULD RESULT IN ACCIDENTAL AIR-BAG DEPLOYMENT AND POSSIBLE PERSONAL INJURY.

RELAY TEST

The defogger relay (Fig. 2) is located in the junction block, on the right cowl side inner panel below the instrument panel in the passenger compartment. Remove the defogger relay from the junction block to perform the following tests:

(1) A relay in the de-energized position should have continuity between terminals 87A and 30, and no continuity between terminals 87 and 30. If OK, go to Step 2. If not OK, replace the faulty relay.

(2) Resistance between terminals 85 and 86 (electromagnet) should be 75 ± 10 ohms. If OK, go to Step 3. If not OK, replace the faulty relay.

(3) Connect a battery to terminals 85 and 86. There should now be continuity between terminals 30 and 87, and no continuity between terminals 87A and 30. If OK, see the Relay Circuit Test in this group. If not OK, replace the faulty relay.

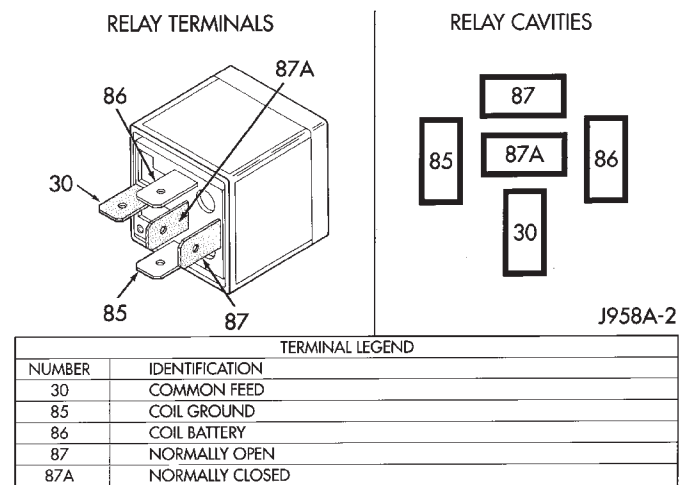


Fig. 2 Defogger Relay

DIAGNOSIS AND TESTING (Continued)**RELAY CIRCUIT TEST**

(1) The relay common feed terminal cavity (30) is connected to battery voltage and should be hot at all times. If OK, go to Step 2. If not OK, repair the open circuit to the PDC fuse as required.

(2) The relay normally closed terminal (87A) is connected to terminal 30 in the de-energized position, but is not used for this application. Go to Step 3.

(3) The relay normally open terminal (87) is connected to the common feed terminal (30) in the energized position. This terminal supplies battery voltage to the fuse in the junction block that feeds the rear glass heating grid and the defogger switch LED indicator. There should be continuity between the cavity for relay terminal 87 and the rear glass heating grid and defogger switch LED indicator at all times. If OK, go to Step 4. If not OK, repair the open circuit as required.

(4) The coil battery terminal (86) is connected to the electromagnet in the relay. It is connected to battery voltage and should be hot at all times. Check for battery voltage at the cavity for relay terminal 86. If OK, go to Step 5. If not OK, repair the open circuit to the PDC fuse as required.

(5) The coil ground terminal (85) is connected to the electromagnet in the relay. This terminal is provided with ground by the Body Control Module (BCM) rear window defogger timer and logic circuitry to energize the defogger relay. There should be continuity to the rear window defogger relay control circuit cavity of the white 24-way BCM wire harness connector. If OK, use a DRB scan tool and the proper Diagnostic Procedures manual to test the BCM. If not OK, repair the open circuit as required.

SERVICE PROCEDURES**REAR GLASS HEATING GRID REPAIR**

Repair of the rear glass heating grid lines, bus bars, terminals or pigtail wires can be accomplished using a Mopar Rear Window Defogger Repair Kit (P/N 4267922) or equivalent.

WARNING: MATERIALS CONTAINED IN THE REPAIR KIT MAY CAUSE SKIN OR EYE IRRITATION. THE KIT CONTAINS EPOXY RESIN AND AMINE TYPE HARDENER, WHICH ARE HARMFUL IF SWALLOWED. AVOID CONTACT WITH THE SKIN AND EYES. FOR SKIN CONTACT, WASH THE AFFECTED AREAS WITH SOAP AND WATER. FOR CONTACT WITH THE EYES, FLUSH WITH PLENTY OF WATER. DO NOT TAKE INTERNALLY. IF TAKEN INTERNALLY, INDUCE VOMITING AND CALL A PHYSICIAN IMMEDIATELY. USE WITH ADEQUATE VENTILATION. DO NOT USE NEAR FIRE OR FLAME. CON-

TAINS FLAMMABLE SOLVENTS. KEEP OUT OF THE REACH OF CHILDREN.

(1) Mask the repair area so that the conductive epoxy can be applied neatly. Extend the epoxy application onto the grid line or the bus bar on each side of the break (Fig. 3).

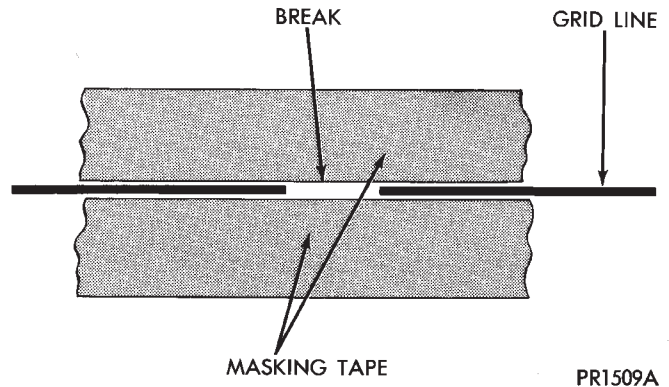


Fig. 3 Grid Line Repair - Typical

(2) Follow the instructions in the repair kit for preparing the damaged area.

(3) Remove the package separator clamp and mix the two conductive epoxy components thoroughly within the packaging. Fold the package in half and cut the center corner to dispense the epoxy.

(4) For grid line repairs, mask the area to be repaired with masking tape or a template.

(5) Apply the epoxy through the slit in the masking tape or template. Overlap both ends of the break by at least 19 mm (0.75 in.).

(6) For a terminal or pigtail wire replacement, mask the adjacent areas so the epoxy can be extended onto the adjacent grid line as well as the bus bar. Apply a thin layer of epoxy to the area where the terminal or pigtail wire was fastened and onto the adjacent grid line.

(7) Apply a thin layer of conductive epoxy to the terminal or bare wire end of the pigtail and place it in the proper location on the bus bar. To prevent the terminal or pigtail wire from moving while the epoxy is curing, it must be wedged or clamped.

(8) Carefully remove the masking tape or template.

CAUTION: Do not allow the glass surface to exceed 204° C (400° F) or the glass may fracture.

(9) Allow the epoxy to cure 24 hours at room temperature, or use a heat gun with a 260° to 371° C (500° to 700° F) range for fifteen minutes. Hold the heat gun approximately 25.4 cm (10 in.) from the repair.

(10) After the conductive epoxy is properly cured, remove the wedge or clamp from the terminal or pig-

SERVICE PROCEDURES (Continued)

tail wire. Do not attach the wire harness connectors until the curing process is complete.

(11) Check the operation of the rear window defogger glass heating grid.

REMOVAL AND INSTALLATION

DEFOGGER SWITCH

WARNING: ON VEHICLES EQUIPPED WITH AIR-BAGS, REFER TO GROUP 8M - PASSIVE RESTRAINT SYSTEMS BEFORE ATTEMPTING ANY STEERING WHEEL, STEERING COLUMN, OR INSTRUMENT PANEL COMPONENT DIAGNOSIS OR SERVICE. FAILURE TO TAKE THE PROPER PRECAUTIONS COULD RESULT IN ACCIDENTAL AIR-BAG DEPLOYMENT AND POSSIBLE PERSONAL INJURY.

(1) Disconnect and isolate the battery negative cable.

(2) Using a trim stick or another suitable wide flat-bladed tool, pry gently around the perimeter edges of the inboard switch pod bezel to release the snap clip retainers. Remove the bezel from the instrument panel.

(3) Remove the three screws that secure the inboard switch pod to the instrument panel (Fig. 4).

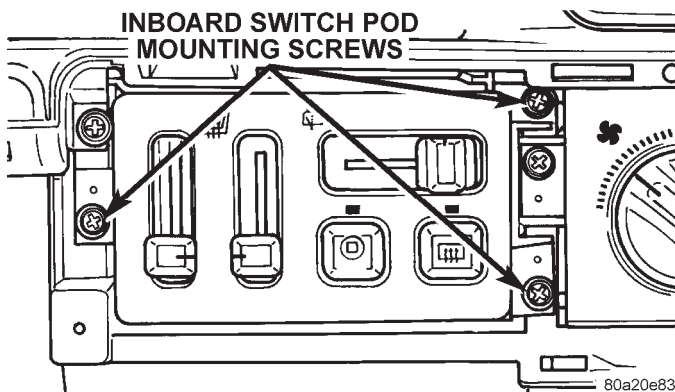


Fig. 4 Inboard Switch Pod Remove/Install

(4) Pull the inboard switch pod out from the instrument panel far enough to access and unplug the wire harness connectors.

(5) Remove the inboard switch pod from the instrument panel.

(6) Reverse the removal procedures to install. Tighten the switch mounting screws to 2.2 N·m (20 in. lbs.).

DEFOGGER RELAY

WARNING: ON VEHICLES EQUIPPED WITH AIR-BAGS, REFER TO GROUP 8M - PASSIVE RESTRAINT SYSTEMS BEFORE ATTEMPTING ANY STEERING WHEEL, STEERING COLUMN, OR INSTRUMENT PANEL COMPONENT DIAGNOSIS OR SERVICE. FAILURE TO TAKE THE PROPER PRECAUTIONS COULD RESULT IN ACCIDENTAL AIR-BAG DEPLOYMENT AND POSSIBLE PERSONAL INJURY.

(1) Disconnect and isolate the battery negative cable.

(2) Remove the fuse access panel by unsnapping it from the right cowl side trim panel.

(3) Remove the push nut that secures the right cowl side trim panel to the junction block stud (Fig. 5).

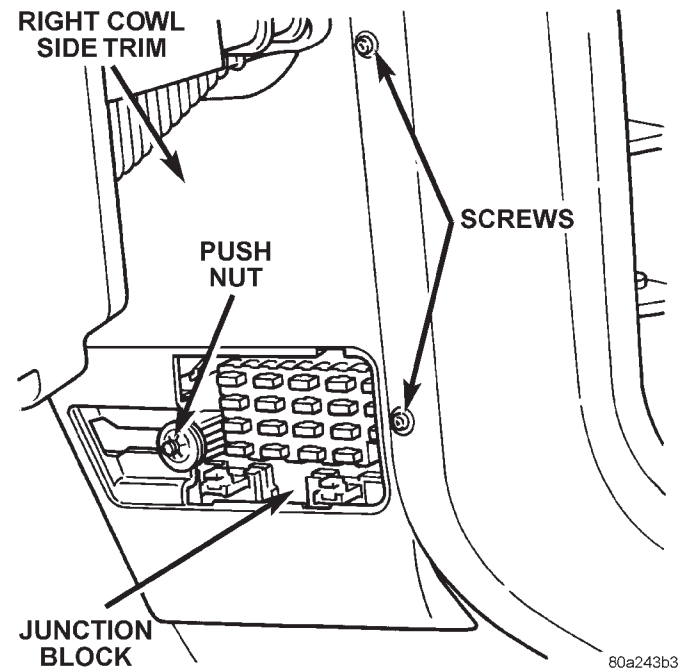


Fig. 5 Right Cowl Side Trim Panel Remove/Install

(4) Remove the two screws that secure the right cowl side trim panel to the right front door opening trim.

(5) Remove the right cowl side trim panel from the right cowl side inner panel.

(6) Unplug the defogger relay from the junction block.

(7) Install the defogger relay by aligning the relay terminals with the cavities in the junction block and pushing the relay firmly into place.

(8) Connect the battery negative cable.

(9) Test the relay operation.

(10) Install the right cowl side trim panel and the fuse access panel.

HEATED SEATS

INDEX

	page		page
GENERAL INFORMATION		HEATED SEAT ELEMENT	9
INTRODUCTION	7	HEATED SEAT SENSOR	9
DESCRIPTION AND OPERATION		HEATED SEAT SWITCH	8
HEATED SEAT CONTROL MODULE	7	HEATED SEAT SYSTEM	8
HEATED SEAT ELEMENT AND SENSOR	8	REMOVAL AND INSTALLATION	
HEATED SEAT SWITCH	7	HEATED SEAT CONTROL MODULE	10
DIAGNOSIS AND TESTING		HEATED SEAT SWITCH	9
HEATED SEAT CONTROL MODULE	9		

GENERAL INFORMATION

INTRODUCTION

Individually controlled electrically heated front seats are available factory-installed optional equipment on this model. The seat heaters will only operate when the ignition switch is in the On position, and the surface temperature at the front seat heating element sensors is below the designed temperature set points of the system. The heated seat system will not operate in ambient temperatures greater than about 32° C (90° F).

There are separate three-position switches for each front seat located in the inboard instrument panel switch pod, just inboard of the steering column. An Off, Low, or High position can be selected with each switch, and Light-Emitting Diodes (LED) for each switch illuminate to give a visual indication that the system is turned on. The Low heat position set point is about 32° C (90° F), and the High heat position set point is about 38° C (100° F). Each switch controls a Heated Seat Control Module (HSCM) mounted to the seat cushion frame under each front seat.

When a seat heater is turned on, a sensor located near the seat cushion electric heater element provides the HSCM with an input indicating the surface temperature of the seat cushion. If the surface temperature input is below the temperature set point for the selected Low or High switch position, a relay within the HSCM energizes the heating elements in the seat cushion and back. When the sensor input indicates the correct temperature set point has been achieved, the HSCM de-energizes the relay. The HSCM will continue to cycle the relay as needed to maintain the temperature set point.

The HSCM will automatically turn off the heating elements if it detects an open in the sensor circuit, or a short in the heating element circuit causing an excessive current draw. The system is also turned off automatically when the ignition switch is turned to

the Off position. The control circuit operates on ignition switched battery feed through a fuse in the junction block. The heating elements operate on battery feed supplied through the power seat circuit breaker in the junction block.

Following are general descriptions of the major components in the heated seat system. Refer to 8W-63 - Power Seat With Heated Seats in Group 8W - Wiring Diagrams for complete circuit descriptions and diagrams.

DESCRIPTION AND OPERATION

HEATED SEAT SWITCH

The heated seat switch is integral to the inboard switch pod, which is mounted in the instrument panel just inboard of the steering column. The two three-position sliding-type switches, one switch for each front seat, provide a resistor multiplexed signal to their respective Heated Seat Control Module (HSCM). Each switch has an Off, Low, and High position so that both the driver and the front seat passenger can select a preferred seat heating mode.

Each switch has a Light-Emitting Diode (LED), which lights to indicate that the heater for the seat that the switch controls is turned on. The heated seat switches and their LED cannot be repaired. If either switch or LED is faulty, the inboard switch pod unit must be replaced.

HEATED SEAT CONTROL MODULE

The Heated Seat Control Module (HSCM) is an electronic thermostatic module designed to operate the electric seat heater elements. Two modules are used in the vehicle, one for each front seat. The HSCM for each seat is installed in a wire harness connector that is located under the seat cushion spring. The wire harness connector is secured by an

DESCRIPTION AND OPERATION (Continued)

integral clip to the inside surface of the outboard seat cushion frame.

Inputs to the module include the instrument panel resistor multiplexed switch signals (which includes the seat cushion temperature sensor circuits), an ignition-switched battery feed, a non-switched battery feed, and a ground. The only HSCM output is the feed for the seat heating elements.

The HSCM cannot be repaired and, if faulty or damaged, it must be replaced.

HEATED SEAT ELEMENT AND SENSOR

Two heated seat heating elements are used in each front seat, one for the seat cushion and the other for the seat back. The two elements for each seat are connected in series with the HSCM.

The temperature sensor is a Negative Temperature Coefficient (NTC) thermistor. One temperature sensor is used for each seat, and it is integrated into the seat cushion heating element.

The heating elements are sewn into the seat cushion cover and seat back cover assemblies, which are serviced individually. The heating elements and temperature sensor cannot be repaired and, if faulty or damaged, the affected seat cover assembly must be replaced. Refer to Group 23 - Body for the seat cushion cover and seat back cover service procedures.

DIAGNOSIS AND TESTING

HEATED SEAT SYSTEM

For circuit descriptions and diagrams, refer to 8W-63 - Power Seat With Heated Seats in Group 8W - Wiring Diagrams.

WARNING: ON VEHICLES EQUIPPED WITH AIR-BAGS, REFER TO GROUP 8M - PASSIVE RESTRAINT SYSTEMS BEFORE ATTEMPTING ANY STEERING WHEEL, STEERING COLUMN, OR INSTRUMENT PANEL COMPONENT DIAGNOSIS OR SERVICE. FAILURE TO TAKE THE PROPER PRECAUTIONS COULD RESULT IN ACCIDENTAL AIR-BAG DEPLOYMENT AND POSSIBLE PERSONAL INJURY.

Before testing the individual components in the heated seat system, check the following:

- If the heated seat switch LED doesn't light with the ignition switch in the On position and the heated seat switch in the Low or High position, check the fuse in the junction block. If the fuse is OK, test the heated seat switch as described in this group. If not OK, repair the shorted circuit or component as required and replace the faulty fuse.
- If the heated seat switch LED lights, but the heating elements don't heat, check the circuit

breaker in the junction block. If the circuit breaker is OK, test the heated seat elements as described in this group. If not OK, replace the faulty circuit breaker.

HEATED SEAT SWITCH

For circuit descriptions and diagrams, refer to 8W-63 - Power Seat With Heated Seats in Group 8W - Wiring Diagrams.

WARNING: ON VEHICLES EQUIPPED WITH AIR-BAGS, REFER TO GROUP 8M - PASSIVE RESTRAINT SYSTEMS BEFORE ATTEMPTING ANY STEERING WHEEL, STEERING COLUMN, OR INSTRUMENT PANEL COMPONENT DIAGNOSIS OR SERVICE. FAILURE TO TAKE THE PROPER PRECAUTIONS COULD RESULT IN ACCIDENTAL AIR-BAG DEPLOYMENT AND POSSIBLE PERSONAL INJURY.

(1) Disconnect and isolate the battery negative cable.

(2) Remove the inboard switch pod from the instrument panel. Check for continuity between the ground circuit cavity of the 10-way switch pod wire harness connector and a good ground. There should be continuity. If OK, go to Step 3. If not OK, repair the open circuit as required.

(3) Connect the battery negative cable. Turn the ignition switch to the On position. Check for battery voltage at the fused ignition switch output circuit cavity of the 10-way switch pod wire harness connector. If OK, turn the ignition switch to the Off position, disconnect and isolate the battery negative cable, and go to Step 4. If not OK, repair the open circuit as required.

(4) With both heated seat switches in the Off position, check for continuity between the fused ignition switch output circuit terminal and the driver heated seat switch output circuit terminal in the 10-way connector receptacle on the back of the inboard switch pod. Repeat this check between the fused ignition switch output circuit terminal and the passenger heated seat switch output circuit terminal. In each case, there should be no continuity. If OK, go to Step 5. If not OK, replace the faulty inboard switch pod.

(5) Move both heated seat switches to the Low position. Using an ohmmeter, check the resistance between the fused ignition switch output circuit terminal and the driver heated seat switch output circuit terminal in the 10-way connector receptacle on the back of the inboard switch pod. Repeat this check between the fused ignition switch output circuit terminal and the passenger heated seat switch output circuit terminal. In each case, the resistance reading should be about 11.5 kilohms. If OK, go to Step 6. If not OK, replace the faulty inboard switch pod.

DIAGNOSIS AND TESTING (Continued)

(6) Move both heated seat switches to the High position. Using an ohmmeter, check the resistance between the fused ignition switch output circuit terminal and the driver heated seat switch output circuit terminal in the 10-way connector receptacle on the back of the inboard switch pod. Repeat this check between the fused ignition switch output circuit terminal and the passenger heated seat switch output circuit terminal. In each case, the resistance reading should be about 6.5 kilohms. If not OK, replace the faulty inboard switch pod.

HEATED SEAT CONTROL MODULE

Before testing the heated seat control module, test the heated seat switch, the heated seat elements, and the heated seat sensor as described in this group. If testing of the heated seat switch, elements, and sensor reveals no problems, proceed as follows. For circuit descriptions and diagrams, refer to 8W-63 - Power Seat With Heated Seats in Group 8W - Wiring Diagrams.

(1) Replace the heated seat control module with a known good unit and test the operation of the heated seats. If OK, discard the faulty heated seat control module. If not OK, go to Step 2.

(2) Test each of the circuits from the heated seat switch, heated seat elements, and heated seat sensor to the heated seat control module. Repair any short or open circuits as required.

HEATED SEAT ELEMENT

The wire harness connectors for the seat cushion and seat back heating elements are located under the seat, near the rear edge of the seat cushion frame. For circuit descriptions and diagrams, refer to 8W-63 - Power Seat With Heated Seats in Group 8W - Wiring Diagrams.

SEAT CUSHION

(1) Disconnect and isolate the battery negative cable. Unplug the 4-way heated seat cushion wire harness connector.

(2) Check for continuity between the two heated seat driver circuit cavities of the seat cushion cover half of the heated seat cushion wire harness connector. There should be continuity. If OK, go to Step 3. If not OK, replace the faulty seat cushion cover.

(3) Check for continuity between one of the heated seat driver circuit cavities of the seat cushion cover half of the heated seat cushion wire harness connector and the seat cushion frame. There should be no continuity. If OK, go to the Seat Back test. If not OK, replace the faulty seat cushion cover.

SEAT BACK

(1) Disconnect and isolate the battery negative cable. Unplug the 2-way heated seat back wire harness connector.

(2) Check for continuity between the heated seat driver circuit cavity and the ground circuit cavity of the seat back cover half of the heated seat back wire harness connector. There should be continuity. If OK, go to Step 3. If not OK, replace the faulty seat back cover.

(3) Check for continuity between the heated seat driver circuit cavity of the seat back cover half of the heated seat back wire harness connector and the seat back frame. There should be no continuity. If OK, test the heated seat sensor as described in this group. If not OK, replace the faulty seat back cover.

HEATED SEAT SENSOR

The wire harness connector for the seat cushion heating element and sensor are located under the seat, near the rear edge of the seat cushion frame. For circuit descriptions and diagrams, refer to 8W-63 - Power Seat With Heated Seats in Group 8W - Wiring Diagrams.

(1) Disconnect and isolate the battery negative cable. Unplug the 4-way heated seat cushion wire harness connector.

(2) Using an ohmmeter, check the resistance between the heated seat switch output circuit cavity and the ground circuit cavity of the seat cushion cover half of the heated seat cushion wire harness connector. The sensor resistance should be between 2 kilohms and 200 kilohms. If OK, test the heated seat control module as described in this group. If not OK, replace the faulty seat cushion cover.

REMOVAL AND INSTALLATION

HEATED SEAT SWITCH

WARNING: ON VEHICLES EQUIPPED WITH AIR-BAGS, REFER TO GROUP 8M - PASSIVE RESTRAINT SYSTEMS BEFORE ATTEMPTING ANY STEERING WHEEL, STEERING COLUMN, OR INSTRUMENT PANEL COMPONENT DIAGNOSIS OR SERVICE. FAILURE TO TAKE THE PROPER PRECAUTIONS COULD RESULT IN ACCIDENTAL AIR-BAG DEPLOYMENT AND POSSIBLE PERSONAL INJURY.

(1) Disconnect and isolate the battery negative cable.

(2) Using a trim stick or another suitable wide flat-bladed tool, pry gently around the perimeter edges of the inboard switch pod bezel to release the

REMOVAL AND INSTALLATION (Continued)

snap clip retainers. Remove the bezel from the instrument panel.

(3) Remove the three screws that secure the inboard switch pod to the instrument panel (Fig. 1).

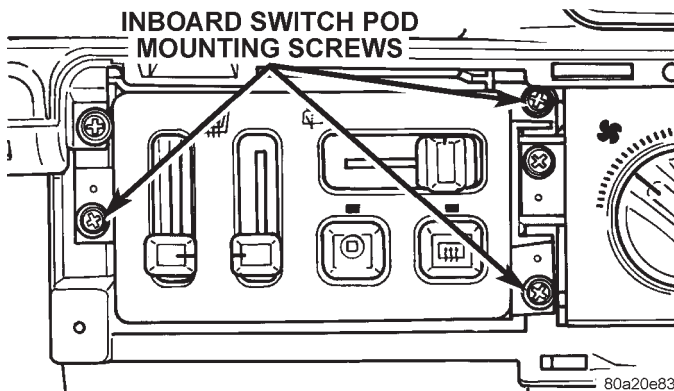


Fig. 1 Inboard Switch Pod Remove/Install

(4) Pull the inboard switch pod out from the instrument panel far enough to access and unplug the wire harness connectors.

(5) Remove the inboard switch pod from the instrument panel.

(6) Reverse the removal procedures to install. Tighten the switch mounting screws to 2.2 N·m (20 in. lbs.).

HEATED SEAT CONTROL MODULE

(1) Move the power seat adjuster to its full up and full forward stop positions.

(2) Disconnect and isolate the battery negative cable.

(3) Remove the three screws that secure the seat side shield to the seat cushion frame.

(4) Pull the seat side shield away from the seat far enough to access and unplug the wire harness connectors from the power seat and power lumbar switches.

(5) Remove the seat side shield from the seat.

(6) Look under the seat to locate the heated seat control module and its wire harness connector. These components are positioned under the seat cushion spring near the center of the outboard seat cushion frame (Fig. 2). The wire harness connector has an integral clip that secures it to the seat cushion frame. The heated seat control module is retained in the wire harness connector by the tension of its terminals in the connector cavities.

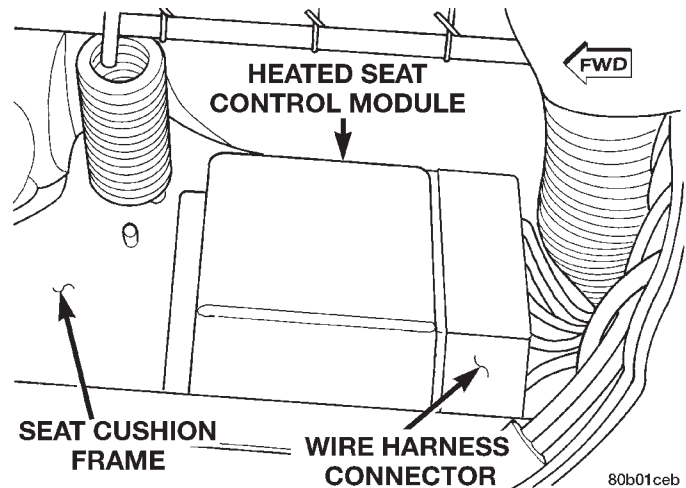


Fig. 2 Heated Seat Control Module Remove/Install - Right Side Shown

WARNING: THERE ARE MANY SHARP METAL EDGES ON THE SEAT CUSHION FRAME AND SEAT ADJUSTER RAILS UNDER THE SEAT. WHEN PERFORMING THIS SERVICE, A LONG-SLEEVED SHIRT AND GLOVES SHOULD BE WORN IN ORDER TO AVOID UNNECESSARY CUTS AND ABRASIONS TO EXPOSED SKIN.

CAUTION: The heated seat control module wire harness connector must be stabilized during module removal or installation. Failure to properly stabilize the connector will result in damage to the integral connector mounting clip that secures the connector to the seat cushion frame.

(7) Kneeling outside the open front door of the vehicle, use the hand nearest the rear of the seat to reach between the top and bottom rails of the power seat adjuster to access and stabilize the heated seat control module wire harness connector.

(8) While still stabilizing the wire harness connector with one hand, use your free hand to reach under the front of the seat cushion to grasp the heated seat control module.

(9) While still stabilizing the wire harness connector with one hand, use a gentle rocking and pulling action with the other hand to unplug the heated seat control module from the wire harness connector.

(10) Reverse the removal procedures to install. Be certain that the heated seat control module terminals are aligned with the cavities in the wire harness connector before pushing the module firmly into place. Tighten the seat side shield mounting screws to 2.2 N·m (20 in. lbs.).

POWER LOCK SYSTEMS

CONTENTS

	page		page
GENERAL INFORMATION			
INTRODUCTION	1	DOOR MODULE	4
MEMORY SYSTEM	2	POWER LIFTGLASS RELEASE SYSTEM	5
POWER LIFTGLASS RELEASE SYSTEM	1	POWER LOCK AND REMOTE KEYLESS ENTRY SYSTEM	4
POWER LOCK SYSTEM	1	POWER LOCK MOTOR	5
REMOTE KEYLESS ENTRY SYSTEM	1	REMOTE KEYLESS ENTRY TRANSMITTER	5
DESCRIPTION AND OPERATION			
BODY CONTROL MODULE	3	SERVICE PROCEDURES	
CIRCUIT BREAKER	3	REMOTE KEYLESS ENTRY TRANSMITTER BATTERY REPLACEMENT	6
DOOR MODULE	2	REMOTE KEYLESS ENTRY TRANSMITTER PROGRAMMING	6
POWER LOCK MOTOR	3	REMOVAL AND INSTALLATION	
POWER LOCK SWITCH	2	DOOR MODULE	6
REMOTE KEYLESS ENTRY RECEIVER	4	POWER LOCK MOTOR	7
REMOTE KEYLESS ENTRY TRANSMITTER	4		
DIAGNOSIS AND TESTING			
CIRCUIT BREAKER	4		

GENERAL INFORMATION

INTRODUCTION

Power lock and Remote Keyless Entry (RKE) systems are standard factory-installed equipment on this model. All of the doors and the liftgate can be locked and unlocked electrically by operating the switch on either front door trim panel, or the buttons on the RKE transmitter. On vehicles with the optional liftgate liftglass, the power liftglass release circuit is also enabled or disabled by the power door lock switch or the RKE transmitter.

Following are general descriptions of the major components in the power lock, RKE, and liftglass latch systems. Refer to 8W-61 - Power Door Locks in Group 8W - Wiring Diagrams for complete circuit descriptions and diagrams. Refer to the owner's manual for more information on the features and use of these systems.

POWER LOCK SYSTEM

The power lock system allows all of the doors and the liftgate to be locked or unlocked electrically by operating the switch on either front door trim panel. This system operates with battery power supplied through a circuit breaker in the junction block, independent of the ignition switch.

The power lock system includes the front door power lock switches, door modules mounted in each

front door, and the power lock motors mounted in each door and the liftgate. The power lock control circuitry and the power lock and unlock relays are integral to the Driver Door Module (DDM) and the Passenger Door Module (PDM).

POWER LIFTGLASS RELEASE SYSTEM

Models equipped with the optional liftgate liftglass feature also have a power operated liftglass release system. This system operates with battery power supplied through a fuse in the junction block, independent of the ignition switch. The power liftglass release system allows the liftglass to be opened by depressing a switch mounted in the top of the liftgate license plate tub.

The liftglass release system includes the liftgate mounted switch, a mechanical latch equipped with an electric release solenoid, and a limit switch integral to the liftgate latch mechanism. The limit switch automatically enables or disables the liftglass release circuitry, depending upon the position of the liftgate latch lock mechanism. The liftgate latch can be unlocked or locked using the key in the liftgate lock cylinder, the power lock system, or the Remote Keyless Entry (RKE) transmitter.

Refer to 8W-61 - Power Door Locks in Group 8W - Wiring Diagrams for circuit descriptions and diagrams. Refer to Group 23 - Body for the power liftglass release system component service procedures.

GENERAL INFORMATION (Continued)

REMOTE KEYLESS ENTRY SYSTEM

The Remote Keyless Entry (RKE) system is a radio frequency system that allows the use of a remote radio transmitter to control the power lock and illuminated entry systems. If the vehicle is so equipped, the RKE transmitter can also control the memory seat, memory mirror, memory radio, and the vehicle theft alarm systems.

The RKE system consists of the remote key fob transmitter and a radio receiver with program logic, which is integral to the Passenger Door Module (PDM). The RKE system can retain the vehicle access codes of two transmitters. The transmitter codes are retained in memory, even if the battery is disconnected.

If a transmitter is faulty or lost, new transmitter vehicle access codes can be programmed into the system using a DRB scan tool and the proper Diagnostic Procedures manual. The RKE system for this vehicle also features a programmable horn chirp feature. This feature allows the customer the option of having the horn chirp request, which the RKE receiver issues as an audible indication that a valid Lock signal has been received from the RKE transmitter, enabled or disabled by the dealer.

On models so equipped, a function of the RKE system made possible by the connection of the PDM to the Chrysler Collision Detection (CCD) data bus network is a panic mode. If the Panic button on the RKE transmitter is depressed, the horn will sound and the exterior lights will flash on the vehicle for about three minutes, or until the Panic button is depressed a second time. A vehicle speed of about 24 kilometers-per-hour (15 miles-per-hour) will also cancel the panic mode.

MEMORY SYSTEM

An electronic memory system is an available option on this model. The memory system is able to store and recall the driver side power seat positions (including power lumbar and recliner positions), and both outside power mirror positions for two drivers. For vehicles with a radio connected to the Chrysler Collision Detection (CCD) data bus network, the memory system is also able to store and recall ten radio station presets (including last station tuned) for two drivers. The memory system will automatically return to all of these settings when the corresponding button (Driver 1 or 2) of the memory switch on the driver side front door trim panel is depressed, or when the doors are unlocked using the corresponding (Driver 1 or 2) Remote Keyless Entry (RKE) transmitter.

The Driver Door Module (DDM) receives hard-wired input from the memory set/select switch on the driver side front door trim panel. The DDM also

receives messages on the CCD data bus from the RKE receiver in the Passenger Door Module (PDM) for the memory select function. The DDM processes these inputs and sends messages to the radio (if CCD data bus capable), the PDM, and the Memory Seat Module (MSM) on the CCD data bus for memory recall.

The CCD data bus network allows the sharing of sensor information. This helps to reduce wire harness complexity, reduce internal controller hardware, and reduce component sensor current loads. At the same time, this system provides increased reliability, enhanced diagnostics, and allows the addition of many new feature capabilities.

This group covers only the conventional diagnostic procedures for the power lock and RKE system components. For diagnosis of the memory system, the use of a DRB scan tool and the proper Diagnostic Procedures manual are recommended. For additional information on the features and functions of the memory system, refer to the owner's manual in the vehicle glove box.

DESCRIPTION AND OPERATION

POWER LOCK SWITCH

The power locks are controlled by a two-way switch that is integral to the Driver Door Module (DDM) and the Passenger Door Module (PDM) mounted in the trim panel of its respective front door. Each switch is illuminated by a light-emitting diode when the ignition switch is turned to the On position. The power lock switch provides a lock or unlock signal to the door module circuitry.

The power lock switches and their lamps cannot be repaired. If the switches are damaged or faulty, the entire PDM or DDM unit must be replaced.

DOOR MODULE

A Driver Door Module (DDM) and a Passenger Door Module (PDM) are used on this model to control and integrate many of the electronic features and functions on the vehicle. Each door module houses both the front power lock and power window switches. The DDM also houses individual switches for each passenger door power window, a power window lockout switch and the power mirror switch.

The DDM and PDM communicate with each other, and with other vehicle modules on the Chrysler Collision Detection (CCD) data bus network. The CCD data bus network allows the sharing of sensor information. This helps to reduce wire harness complexity, internal controller hardware, and component sensor current loads. At the same time, this system provides increased reliability, enhanced diagnostics, and allows the addition of many new feature capabilities.

DESCRIPTION AND OPERATION (Continued)

The DDM circuitry controls the output to the driver front door power lock motor. The PDM circuitry controls the output to the power lock motors for the remaining doors and the liftgate. When a door lock switch is actuated, the door module circuitry for that switch sends a message to the other door module on the CCD data bus to activate the output to the remaining power lock motor(s).

Some of the features and functions of the power lock and Remote Keyless Entry (RKE) systems made possible because of the communication of the door modules on the CCD data bus network include:

- A door-lock inhibit feature which prevents the power lock system from being energized with a door switch if the key is in the ignition and/or the headlamps are on with the driver door open. However, the locks can still be operated manually with a key or energized with the RKE transmitter.

- A rolling door locks feature will automatically lock all of the doors and the liftgate, after the vehicle reaches a speed of about 24 kilometers-per-hour (15 miles-per-hour) or greater. This feature will also lock the doors if a door is opened, then closed again at any speed above 24 kilometers-per-hour (15 miles-per-hour). Rolling door locks is a programmable feature of the power lock system. This feature can be enabled or disabled using the DRB scan tool and the proper Diagnostic Procedures manual.

- An RKE system panic mode, on models so equipped. If the Panic button on the RKE transmitter is depressed, the horn will sound and the exterior lights will flash on the vehicle for about three minutes, or until the Panic button is depressed a second time. A vehicle speed of about 24 kilometers-per-hour (15 miles-per-hour) will also cancel the panic mode.

- A programmable feature of the RKE system is the enabling or disabling of the horn chirp following the RKE Lock function. This feature can be enabled or disabled using the DRB scan tool and the proper Diagnostic Procedures manual.

- Another programmable feature is the enabling or disabling of the RKE system unlocking the driver door only, or all doors upon one depression of the transmitter Unlock button. If the driver door only mode is enabled, a second depression of the Unlock button within five seconds will unlock all of the doors and the liftgate. This feature can be enabled or disabled using the DRB scan tool and the proper Diagnostic Procedures manual.

For diagnosis of the DDM, PDM, or the CCD data bus network, a DRB scan tool and the proper Diagnostic Procedures manual are recommended. The DDM and the PDM cannot be repaired and, if damaged or faulty, they must be replaced.

BODY CONTROL MODULE

A Body Control Module (BCM) is used on this model to control and integrate many of the electronic functions and features included on the vehicle. The BCM contains a central processing unit and interfaces with other modules in the vehicle on the Chrysler Collision Detection (CCD) data bus network.

The CCD data bus network allows the sharing of sensor information. This helps to reduce wire harness complexity, reduce internal controller hardware, and reduce component sensor current loads. At the same time, this system provides increased reliability, enhanced diagnostics, and allows the addition of many new feature capabilities.

One of the functions and features that the BCM supports and controls on models so equipped, is the Remote Keyless Entry (RKE) Panic Mode. The BCM receives input from the RKE receiver in the Passenger Door Module (PDM) on the CCD data bus. The programming in the BCM allows it to process the information from this input and send control outputs to the headlamp relay, horn relay, and park lamp relay to accomplish the panic mode functions.

The BCM is mounted under the driver side outboard end of the instrument panel, behind the instrument panel support armature and below the outboard switch pod. Refer to Group 8E - Instrument Panel Systems for the removal and installation procedures. For diagnosis of the BCM or the CCD data bus, the use of a DRB scan tool and the proper Diagnostic Procedures manual are recommended. The BCM can only be serviced by an authorized electronic repair station. Refer to the latest Warranty Policies and Procedures manual for a current listing of authorized electronic repair stations.

POWER LOCK MOTOR

In the power lock and Remote Keyless Entry (RKE) systems, the locks are actuated by a reversible electric motor mounted within each door and the liftgate. The driver front door lock motor direction is controlled by the battery and ground feeds from the Driver Door Module (DDM). The remaining door lock motors and the liftgate lock motor are controlled by the battery and ground feeds from the Passenger Door Module (PDM).

The power lock motors cannot be repaired and, if faulty or damaged, the entire motor must be replaced.

CIRCUIT BREAKER

An automatic resetting circuit breaker in the junction block is used to protect the power lock system circuit. The circuit breaker can protect the system from a short circuit, or from an overload condition

DESCRIPTION AND OPERATION (Continued)

caused by an obstructed or stuck lock motor, latch, or lock linkage.

The circuit breaker cannot be repaired and, if faulty, it must be replaced.

REMOTE KEYLESS ENTRY TRANSMITTER

The Remote Keyless Entry (RKE) system transmitter is equipped with three buttons, labeled Lock, Unlock, and Panic. It is also equipped with a key ring and is designed to serve as a key fob. The operating range of the transmitter radio signal is up to 7 meters (23 feet) from the RKE receiver.

Each transmitter has a different vehicle access code, which must be programmed into the memory of the RKE receiver in the vehicle in order to operate the RKE system. In addition, vehicles with the memory seat/mirror/radio system must have their access codes programmed into the receiver so that the molded-in numbers "1" or "2" on the back of the transmitter case coincide with the memory "1" and "2" buttons of the memory set switch in the vehicle.

The transmitter operates on two Duracell DL2016 (or equivalent) batteries. Typical battery life is from one to two years. The transmitter cannot be repaired and, if faulty or damaged, it must be replaced.

REMOTE KEYLESS ENTRY RECEIVER

The Remote Keyless Entry (RKE) receiver is a radio frequency unit contained in the Passenger Door Module (PDM). The PDM also contains the program circuitry for the RKE system. The PDM is located inside the passenger side front door, and is secured to the door trim panel.

The RKE receiver has a memory function to retain the vehicle access codes of two RKE transmitters. The receiver is designed to retain the transmitter codes in memory, even if the battery is disconnected.

The RKE receiver is energized by one of three messages from the RKE transmitter; Unlock, Lock, or Panic. The PDM circuitry responds to these messages to lock or unlock the power lock motors that it controls. The PDM circuitry also puts Lock, Unlock, and Panic messages on the Chrysler Collision Detection (CCD) data bus.

These messages will result in the Driver Door Module (DDM) locking or unlocking the driver side front door, and/or the Body Control Module (BCM) initiating the proper Panic, Horn Chirp, Illuminated Entry, and Vehicle Theft Alarm functions. If the vehicle is equipped with the optional memory system, the proper CCD Unlock message will also result in the DDM initiating its memory recall functions.

For diagnosis of the RKE receiver, the PDM, the DDM, or the CCD data bus, refer to the proper Diagnostic Procedures manual. The RKE receiver is only

serviced as a unit with the PDM and, if faulty or damaged, the PDM unit must be replaced.

DIAGNOSIS AND TESTING

POWER LOCK AND REMOTE KEYLESS ENTRY SYSTEM

As a preliminary diagnosis for the power lock and Remote Keyless Entry (RKE) systems, note the system operation while you actuate both the Lock and Unlock functions with the power lock switches and the RKE transmitter. Then, proceed as follows:

- If the power lock system fails to function with either the power lock switches or the RKE transmitter, see the Circuit Breaker diagnosis in this group.
- If the power lock system functions with both power lock switches, but not with the RKE transmitter, see the Remote Keyless Entry Transmitter diagnosis in this group.
- If the power lock system functions with the RKE transmitter, but not with one or both power lock switches, see the Door Module diagnosis in this group.
- If one power lock motor fails to operate with the power lock switches or the RKE transmitter, see the Power Lock Motor diagnosis in this group.

CIRCUIT BREAKER

For circuit descriptions and diagrams, refer to 8W-61 - Power Door Locks in Group 8W - Wiring Diagrams.

(1) Locate the circuit breaker in the junction block. Pull out the circuit breaker slightly, but be sure that the terminals still contact the terminals in the junction block cavities.

(2) Connect the negative lead of a 12-volt DC voltmeter to a good ground.

(3) With the voltmeter positive lead, check both terminals of the circuit breaker for battery voltage.

If only one terminal has battery voltage, the circuit breaker is faulty and must be replaced. If neither terminal has battery voltage, repair the open circuit from the Power Distribution Center (PDC) as required. If the circuit breaker checks OK, but no power locks operate, see the diagnosis for the Door Module in this group.

DOOR MODULE

NOTE: The following tests may not prove conclusive in the diagnosis of this component. The most reliable, efficient, and accurate means to diagnose this system involves the use of a DRB scan tool and the proper Diagnostic Procedures manual.

DIAGNOSIS AND TESTING (Continued)

Remember, the DDM circuitry controls the output to the driver side front door power lock motor. The PDM circuitry controls the output to the power lock motors for the remaining doors and the liftgate. For circuit descriptions and diagrams, refer to 8W-61 - Power Door Locks in Group 8W - Wiring Diagrams.

(1) Disconnect and isolate the battery negative cable. Remove the front door trim panel. Go to Step 2.

(2) Check the 12-way door module wire harness connector to see that it is fully seated in the door module receptacle. If OK, go to Step 3. If not OK, install the wire harness connector properly.

(3) Unplug the 12-way door module wire harness connector from the door module. Check for continuity between the ground circuit cavity of the door module wire harness connector and a good ground. There should be continuity. If OK, go to Step 4. If not OK, repair the open circuit as required.

(4) Connect the battery negative cable. Check for battery voltage at the fused B(+) circuit cavity of the 12-way door module wire harness connector. If OK, go to Step 5. If not OK, repair the open circuit as required.

(5) Disconnect and isolate the battery negative cable. Check for continuity between the door lock driver circuit cavity of the 12-way door module wire harness connector and a good ground. Repeat the check for the door unlock driver circuit cavity of the door module wire harness connector. In each case there should be no continuity. If OK, go to Step 6. If not OK, repair the short circuit as required.

(6) Plug the 12-way door module wire harness connector back into the door module. Unplug the inoperative power lock motor wire harness connector. Connect the battery negative cable. Go to Step 7.

(7) Connect the probes of a reversible DC digital voltmeter to the body wire harness half of the power lock motor wire harness connector. Observe the voltmeter while actuating the power lock switch in the lock and unlock directions. There should be a short 12-volt voltage spike as the switch is moved to both the lock and unlock positions, and no voltage in the neutral position. If OK, see the diagnosis for the Power Lock Motor in this group. If not OK, replace the faulty door module.

POWER LOCK MOTOR

Remember, the Driver Door Module (DDM) circuitry controls the output to the driver side front door power lock motor. The Passenger Door Module (PDM) circuitry controls the output to the power lock motors for the remaining doors and the liftgate. For circuit descriptions and diagrams, refer to 8W-61 - Power Door Locks in Group 8W - Wiring Diagrams.

(1) Check each power lock motor for correct operation while moving the power lock switch to both the Lock and Unlock positions. If all of the power lock motors are inoperative, go to Step 2. If one power lock motor is inoperative, go to Step 3.

(2) If all of the power lock motors except the driver side front door are inoperative, the problem may be caused by one shorted motor. Unplugging a shorted power lock motor from the power lock circuit will allow the good power lock motors to operate. Unplug each PDM-controlled power lock motor wire harness connector, one at a time, and recheck both the lock and unlock functions by operating the power lock switch. If all of the PDM-controlled power lock motors are still inoperative after the above test, check for a short or open circuit between the power lock motors and the PDM. If unplugging one power lock motor causes the other motors to become functional, go to Step 3 to test the unplugged motor.

(3) Once it is determined which lock motor is inoperative, that motor can be tested as follows. Unplug the wire harness connector at the inoperative motor. Apply 12 volts to the motor terminals to check its operation in one direction. Reverse the polarity to check the operation in the other direction. If OK, repair the short or open circuits to the DDM or PDM as required. If not OK, replace the faulty power lock motor.

REMOTE KEYLESS ENTRY TRANSMITTER

(1) Replace the Remote Keyless Entry (RKE) transmitter batteries. See Remote Keyless Entry Transmitter Battery Replacement in this group for the procedures. Test each of the transmitter functions. If OK, discard the faulty batteries. If not OK, go to Step 2.

(2) Perform the Remote Keyless Entry Transmitter Programming procedure with the suspect transmitter and another known good transmitter. Use a DRB scan tool, as described in the proper Diagnostic Procedures manual.

(3) Test the RKE system operation with both transmitters. If both transmitters fail to operate the power lock system, use a DRB scan tool and the proper Diagnostic Procedures manual for further diagnosis of the RKE system. If the known good transmitter operates the power locks and the suspect transmitter does not, replace the faulty transmitter.

NOTE: Be certain to perform the Remote Keyless Entry Transmitter Programming procedure again following this test. This procedure will erase the access code of the test transmitter from the RKE receiver.

DIAGNOSIS AND TESTING (Continued)

POWER LIFTGLASS RELEASE SYSTEM

For circuit descriptions and diagrams, refer to 8W-61 - Power Door Locks in Group 8W - Wiring Diagrams.

(1) Check the fuse in the junction block. If OK, go to Step 2. If not OK, repair the shorted circuit or component as required and replace the faulty fuse.

(2) Check for battery voltage at the fuse in the junction block. If OK, go to Step 3. If not OK, repair the open circuit as required.

(3) Unplug the liftglass limit switch wire harness connector. Check for battery voltage at the fused B(+) circuit cavity of the limit switch wire harness connector. If OK, go to Step 4. If not OK, repair the open circuit as required.

(4) Check for continuity between the two terminals of the liftglass limit switch. There should be continuity with the liftgate latch unlocked, and no continuity with the latch locked. If OK, go to Step 5. If not OK, replace the faulty limit switch.

(5) Unplug the liftglass push button switch wire harness connector. With the liftgate latch unlocked, check for battery voltage at the liftglass limit switch output circuit cavity of the push button switch wire harness connector. If OK, go to Step 6. If not OK, repair the open circuit as required.

(6) Check for continuity between the two terminals of the liftglass push button switch. There should be no continuity. Depress the switch, there should now be continuity. If OK, go to Step 7. If not OK, replace the faulty push button switch.

(7) Unplug the liftglass release solenoid wire harness connector. Check for continuity between the ground circuit cavity of the wire harness connector and a good ground. There should be continuity. If OK, go to Step 8. If not OK, repair the open circuit as required.

(8) With the liftgate latch unlocked and the liftglass push button switch depressed, check for battery voltage at the liftglass push button output circuit cavity of the liftglass release solenoid wire harness connector. If OK, replace the faulty solenoid. If not OK, repair the open circuit as required.

SERVICE PROCEDURES

REMOTE KEYLESS ENTRY TRANSMITTER BATTERY REPLACEMENT

The Remote Keyless Entry (RKE) transmitter case snaps open and shut for battery access. To replace the RKE transmitter batteries:

(1) Using a trim stick or another suitable wide flat-bladed tool, gently pry at the center seam of the transmitter case halves near the key ring until the two halves unsnap.

(2) Lift the back half of the transmitter case off of the transmitter.

(3) Remove the two batteries from the transmitter.

(4) Replace the two batteries with new Duracell DL2016, or their equivalent. Be certain that the batteries are installed with their polarity correctly oriented.

(5) Align the two transmitter case halves with each other, and squeeze them firmly together until they snap back into place.

REMOTE KEYLESS ENTRY TRANSMITTER PROGRAMMING

To program the Remote Keyless Entry (RKE) transmitter access codes into the RKE receiver in the Passenger Door Module (PDM) requires the use of a DRB scan tool. Refer to the proper Diagnostic Procedures manual for more information.

REMOVAL AND INSTALLATION

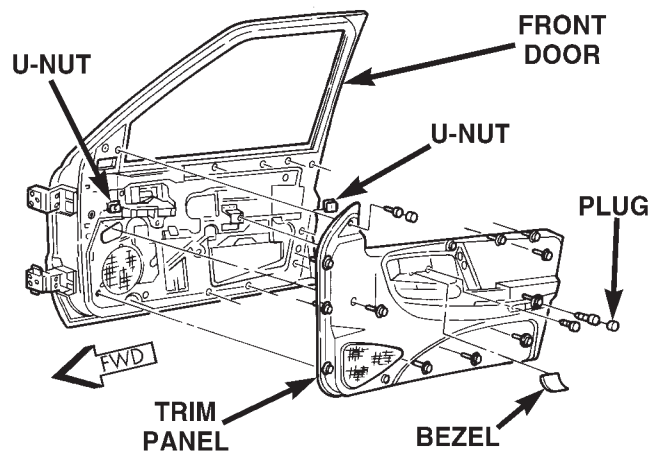
DOOR MODULE

Before replacing the door module, use a DRB scan tool to determine the current settings for the door module programmable features. These settings should be duplicated in the replacement door module using the DRB scan tool, before returning the vehicle to service.

(1) Disconnect and isolate the battery negative cable.

(2) Remove the bezel near the inside door latch release handle by inserting a straight-bladed screwdriver in the notched end of the bezel and prying gently upwards.

(3) Remove the screw located beneath the bezel that secures the front door trim panel to the inner door panel (Fig. 1).



80a77419

Fig. 1 Front Door Trim Panel Remove/Install

REMOVAL AND INSTALLATION (Continued)

- (4) Remove the trim cap and screw near the rear of the front door armrest.
- (5) Remove the trim cap and screw at the upper front corner of the front door trim panel.
- (6) Remove the screw located above the front door speaker grille on the front door trim panel.
- (7) Using a trim stick or another suitable wide flat-bladed tool, gently pry the front door trim panel away from the door around the perimeter to release the trim panel retainers.

NOTE: To aid in the removal of the trim panel, start at the bottom of the panel.

- (8) Pull the front door trim panel away from the inner door panel far enough to access and unplug the wire harness connectors from the door module and, if the vehicle is so equipped, from the front door courtesy lamp.
- (9) Remove the five screws that secure the door module to the back of the front door trim panel (Fig. 2).

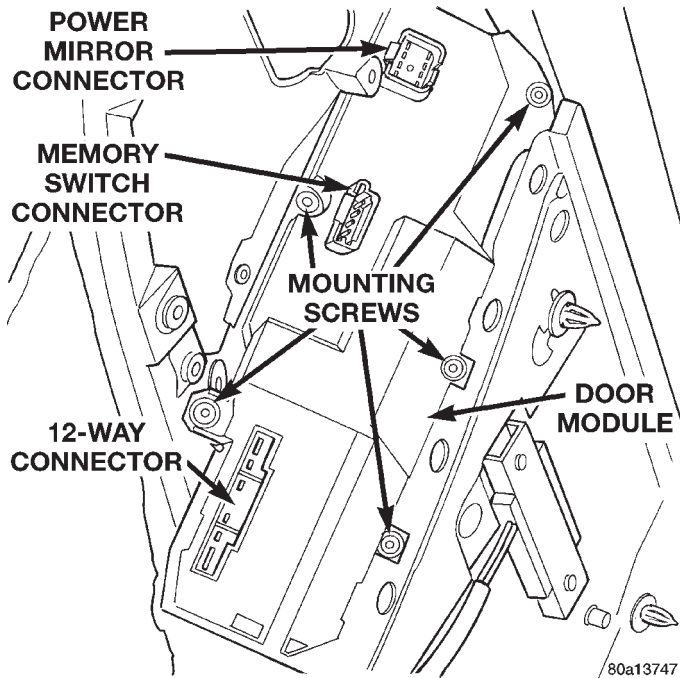


Fig. 2 Door Module Remove/Install

- (10) Remove the door module from the trim panel.
- (11) Reverse the removal procedures to install. Tighten the mounting screws to 2.2 N·m (20 in. lbs.).

NOTE: If a new door module is installed, the programmable features must be enabled and/or disabled to the customer's preferred settings. Use a DRB scan tool and the proper Diagnostic Procedures manual to perform these operations.

POWER LOCK MOTOR

FRONT DOOR

The front door power lock motor is integral to the front door latch unit. If the front door power lock motor is faulty or damaged, the entire latch unit must be replaced. Refer to Group 23 - Body for the front door latch service procedures.

REAR DOOR

The rear door power lock motor is integral to the rear door latch unit. If the rear door power lock motor is faulty or damaged, the entire latch unit must be replaced. Refer to Group 23 - Body for the rear door latch service procedures.

LIFTGATE

- (1) Disconnect and isolate the battery negative cable.
- (2) Open the liftgate.
- (3) Remove the screws that secure the liftgate lower trim panel to the liftgate inner panel (Fig. 3).

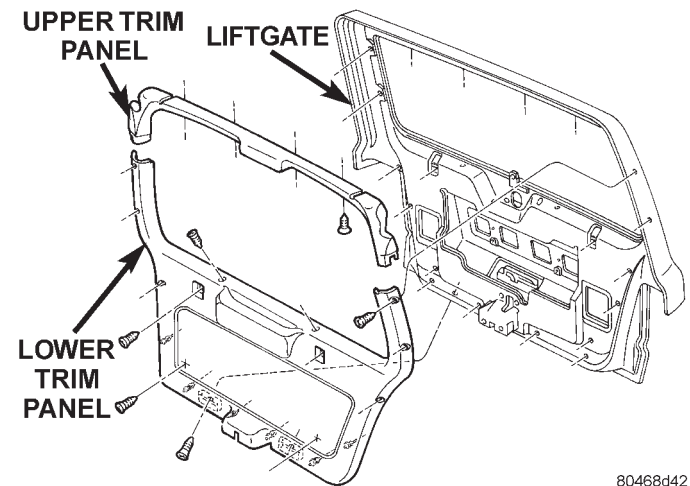


Fig. 3 Liftgate Trim Panel Remove/Install

- (4) Using a trim stick or another suitable wide flat-bladed tool, gently pry the perimeter edges of the trim panel away from the liftgate inner panel to release the retainers.

NOTE: To aid in the removal of the trim panel, start at the bottom of the panel.

- (5) Remove the liftgate trim panel from the vehicle.

REMOVAL AND INSTALLATION (Continued)

(6) Reach through the liftgate inner panel access hole and disconnect the lock actuator motor linkage clip at the liftgate latch handle (Fig. 4).

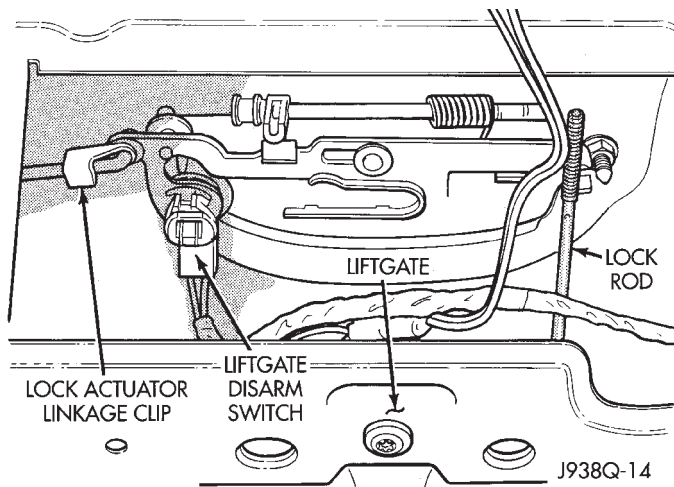


Fig. 4 Lock Actuator Motor Linkage Remove/Install

(7) Remove the two screws that secure the power lock actuator motor to the liftgate inner panel (Fig. 5).

(8) Pull the power lock motor out through the liftgate inner panel access hole far enough to access the wire harness connector.

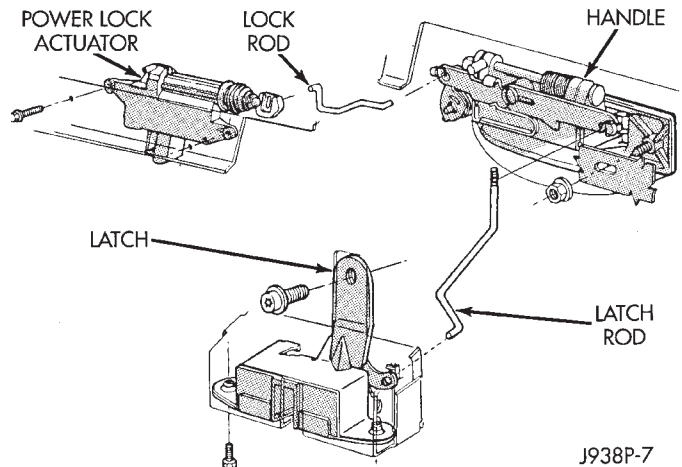


Fig. 5 Liftgate Lock Motor Remove/Install

(9) Unplug the wire harness connector from the power lock motor.

(10) Remove the power lock motor from the liftgate.

(11) Reverse the removal procedures to install. Tighten the power lock actuator motor mounting screws to 3 N·m (28 in. lbs.).

VEHICLE THEFT/SECURITY SYSTEMS

CONTENTS

	page		page
GENERAL INFORMATION			
ARMING	2	LIFTGLASS AJAR SWITCH	3
DISARMING	2	PARK LAMP RELAY	3
ENABLING	1	SET LAMP	4
INTRODUCTION	1	DIAGNOSIS AND TESTING	
POWER-UP MODE	2	RELAYS	4
TAMPER ALERT	2	VEHICLE THEFT SECURITY SYSTEM	4
DESCRIPTION AND OPERATION			
AUTO HEADLAMP RELAY	3	REMOVAL AND INSTALLATION	
BODY CONTROL MODULE	2	AUTO HEADLAMP AND PARK LAMP RELAYS ..	8
DOOR AJAR SWITCH	3	DOOR AJAR SWITCH	5
DOOR LOCK CYLINDER SWITCH	3	DOOR LOCK CYLINDER SWITCH	5
HORN RELAY	3	HORN RELAY	8
LIFTGATE AJAR SWITCH	3	LIFTGATE AJAR SWITCH	6
LIFTGATE LOCK CYLINDER SWITCH	3	LIFTGATE LOCK CYLINDER SWITCH	7
		LIFTGLASS AJAR SWITCH	7
		SET LAMP	8

GENERAL INFORMATION

INTRODUCTION

The Vehicle Theft Security System (VTSS) is an available factory-installed option on this model. This system is designed to provide perimeter protection against unauthorized use or tampering by monitoring the vehicle doors, liftgate, and ignition system. If unauthorized use or tampering is detected, the system responds by sounding the horn, flashing the exterior lamps, and providing an engine no-run feature. The VTSS can be disarmed by unlocking the vehicle with the key in either front door lock cylinder or using the Remote Keyless Entry (RKE) transmitters.

Following are some general descriptions of the features of the VTSS. Refer to the vehicle owner's manual for additional information on the use and operation of this system. Refer to 8W-39 - Vehicle Theft Security System in Group 8W - Wiring Diagrams for complete circuit descriptions and diagrams.

ENABLING

The Vehicle Theft Security System (VTSS) features are provided by two electronic modules in the vehicle; the Powertrain Control Module (PCM) located in the engine compartment, and the Body Control Module (BCM) located in the passenger compartment. Both of these modules must have their respective VTSS

functions electronically enabled in order for the VTSS to perform as designed.

The VTSS engine no-run feature is disabled when it is shipped from the factory. This is done by programming within the Powertrain Control Module (PCM). The logic in the PCM prevents the VTSS engine no-run feature from arming until the engine start counter within the PCM sees twenty engine starts. The VTSS no-run feature must be enabled when the vehicle is received from the assembly plant.

The preferred method for enabling the VTSS engine no-run feature is to electronically advance the PCM engine start counter using a DRB scan tool. Refer to the Vehicle Theft Security System menu item on the DRB scan tool for the procedures. Once this condition has been met, the PCM will allow the engine no-run feature to arm. Once the VTSS engine no-run feature has been enabled in the PCM, it cannot be disabled. The same VTSS engine no-run feature enable logic will apply anytime the PCM is replaced with a new unit.

The remaining VTSS features are controlled by the BCM. The logic in the BCM keeps its VTSS features dormant until it is enabled using a DRB scan tool. The VTSS features of the BCM are enabled on vehicles equipped with the VTSS option at the factory, but a service replacement BCM must be enabled by the dealer with a DRB scan tool anytime the BCM is replaced with a new unit.

GENERAL INFORMATION (Continued)**ARMING**

Passive arming of the Vehicle Theft Security System (VTSS) occurs when the vehicle is exited with the key removed from the ignition switch, the headlamps are turned off, and the doors are locked using the power lock switch. The power lock switch will not function if the key is in the ignition switch or the headlamps are on with the driver side front door open. The VTSS will not arm if either front door or the liftgate are locked using the key in the lock cylinder or using the mechanical lock button.

Active arming of the VTSS occurs when the Remote Keyless Entry (RKE) transmitter is used to lock the vehicle, even if the doors and/or the liftgate are open when the RKE transmitter Lock button is depressed. However, the VTSS arming will not be complete until all of the doors and the liftgate are closed.

Following successful passive or active VTSS arming, the VTSS set lamp on the top of the instrument panel will flash rapidly for about fifteen seconds after the illuminated entry system times out. This indicates that VTSS arming is in progress. Once the fifteen second arming function is successfully completed, the set lamp will flash at a slower rate to indicate that the VTSS is armed.

DISARMING

Passive disarming of the Vehicle Theft Security System (VTSS) occurs when the vehicle is unlocked using the key to unlock either front door or the liftgate. Active disarming of the VTSS occurs when the vehicle is unlocked by depressing the Unlock button of the Remote Keyless Entry (RKE) transmitter.

Once the alarm has been activated (horn sounding, exterior lamps flashing, and the engine no-run feature), either disarming method will also deactivate the alarm.

Depressing the Panic button on the RKE transmitter will also disarm the VTSS, but the horn will sound and the exterior lamps will flash for about three minutes as part of the Panic feature function. Refer to Group 8P - Power Lock Systems for more information on the Panic feature.

POWER-UP MODE

When the armed Vehicle Theft Security System (VTSS) senses that the battery has been disconnected and reconnected, it enters its power-up mode. In the power-up mode the alarm system remains armed following a battery failure or disconnect. If the VTSS was armed prior to a battery disconnect or failure, the system will have to be actively or passively disarmed after the battery is reconnected.

The power-up mode will also apply if the battery goes dead while the system is armed, and battery

jump-starting is attempted. The engine no-run feature will prevent the engine from starting until the alarm system has been actively or passively disarmed.

TAMPER ALERT

The Vehicle Theft Security System (VTSS) tamper alert will sound the horn three times upon disarming, if the alarm was activated and has since timed-out (about eighteen minutes). This feature alerts the vehicle operator that the VTSS was activated while the vehicle was unattended.

DESCRIPTION AND OPERATION**BODY CONTROL MODULE**

A Body Control Module (BCM) is used on this model to control and integrate many of the electronic functions and features included on the vehicle. The BCM contains a central processing unit and interfaces with other modules in the vehicle on the Chrysler Collision Detection (CCD) data bus network.

The CCD data bus network allows the sharing of sensor information. This helps to reduce wire harness complexity, reduce internal controller hardware, and reduce component sensor current loads. At the same time, this system provides increased reliability, enhanced diagnostics, and allows the addition of many new feature capabilities.

One of the functions and features that the BCM supports and controls, is the Vehicle Theft Security System (VTSS). In the VTSS, the BCM receives CCD message inputs from the Passenger Door Module (PDM), which contains the Remote Keyless Entry (RKE) receiver. In addition to the information received on the CCD data bus, the BCM receives hard-wired inputs from the door ajar, door lock cylinder, ignition, liftgate ajar, liftgate lock cylinder, and liftglass ajar switches. The programming in the BCM allows it to process the information from all of its inputs and send control outputs to energize or de-energize the auto headlamp relay, horn relay, park lamp relay, Powertrain Control Module (PCM), and the security set lamp.

The BCM is mounted under the driver side outboard end of the instrument panel, behind the instrument panel support armature and below the outboard switch pod. Refer to Group 8E - Instrument Panel Systems for the removal and installation procedures. For diagnosis of the BCM or the CCD data bus, the use of a DRB scan tool and the proper Diagnostic Procedures manual are recommended. The BCM can only be serviced by an authorized electronic repair station. Refer to the latest Warranty Policies and Procedures manual for a current listing of authorized electronic repair stations.

DESCRIPTION AND OPERATION (Continued)**DOOR AJAR SWITCH**

The door ajar switches are mounted to the pillar in the rear of each door opening. They are plunger-type switches that are case grounded to the pillar. When the door is open the switch is closed, and when the door is closed the switch is open.

The door ajar switches cannot be repaired and, if faulty or damaged, they must be replaced.

DOOR LOCK CYLINDER SWITCH

The door lock cylinder switches are mounted to the back of the key lock cylinder inside each front door. They are normally-open momentary switches that close to ground only when the lock cylinder is rotated to the unlock position.

The door lock cylinder switches cannot be repaired and, if faulty or damaged, they must be replaced.

LIFTGATE AJAR SWITCH

The liftgate ajar switch is integral to the liftgate latch assembly on the liftgate. It is a momentary-type switch that is open when the liftgate is closed, and closed when the liftgate is open.

The liftgate ajar switch cannot be repaired and, if faulty or damaged, the liftgate latch assembly must be replaced.

LIFTGATE LOCK CYLINDER SWITCH

The liftgate lock cylinder switch is mounted to the back of the key lock cylinder inside the liftgate. It is a normally-open momentary switch that closes to ground only when the lock cylinder is rotated to the unlock position.

The liftgate lock cylinder switch cannot be repaired and, if faulty or damaged, it must be replaced.

LIFTGLASS AJAR SWITCH

The liftglass ajar switch is integral to the liftglass latch assembly on the liftgate. It is a momentary-type switch that is open when the liftglass is closed, and closed when the liftglass is open.

The liftglass ajar switch cannot be repaired and, if faulty or damaged, the liftglass latch assembly must be replaced.

AUTO HEADLAMP RELAY

The auto headlamp relay is a International Standards Organization (ISO) micro-relay. The terminal designations and functions are the same as a conventional ISO relay. However, the micro-relay terminal orientation (or footprint) is different, current capacity is lower, and the relay case dimensions are smaller than those of the conventional ISO relay.

The auto headlamp relay is a electromechanical device that switches battery current to the headlamps when the Body Control Module (BCM) grounds

the relay coil. See the Diagnosis and Testing section of this group for more information on the operation of the auto headlamp relay.

The auto headlamp relay is located in the junction block, on the right cowl side inner panel below the instrument panel in the passenger compartment.

The auto headlamp relay cannot be repaired and, if faulty or damaged, it must be replaced.

HORN RELAY

The horn relay is a International Standards Organization (ISO) micro-relay. The terminal designations and functions are the same as a conventional ISO relay. However, the micro-relay terminal orientation (or footprint) is different, current capacity is lower, and the relay case dimensions are smaller than those of the conventional ISO relay.

The horn relay is a electromechanical device that switches battery current to the horn when the horn switch or the Body Control Module (BCM) grounds the relay coil. See the Diagnosis and Testing section of this group for more information on the operation of the horn relay.

The horn relay is located in the Power Distribution Center (PDC), in the engine compartment. Refer to the PDC label for relay identification and location.

If a problem is encountered with a continuously sounding horn, it can usually be quickly resolved by removing the horn relay from PDC until further diagnosis is completed.

The horn relay cannot be repaired and, if faulty or damaged, it must be replaced.

PARK LAMP RELAY

The park lamp relay is a International Standards Organization (ISO) micro-relay. The terminal designations and functions are the same as a conventional ISO relay. However, the micro-relay terminal orientation (or footprint) is different, current capacity is lower, and the relay case dimensions are smaller than those of the conventional ISO relay.

The park lamp relay is a electromechanical device that switches battery current to the park lamps when the Body Control Module (BCM) grounds the relay coil. See the Diagnosis and Testing section of this group for more information on the operation of the park lamp relay.

The park lamp relay is located in the junction block, on the right cowl side panel below the instrument panel in the passenger compartment. The park lamp relay can be accessed by removing the fuse access panel and the right cowl side trim panel.

The park lamp relay cannot be repaired and, if faulty or damaged, it must be replaced.

DESCRIPTION AND OPERATION (Continued)**SET LAMP**

The Vehicle Theft Security System (VTSS) set lamp is a red light-emitting diode mounted with the auto headlamp ambient light sensor on top of the instrument panel near the driver side defroster outlet. The set lamp receives fused battery feed at all times and is grounded by the Body Control Module (BCM) to give a visual indication of the VTSS status.

The set lamp cannot be repaired and, if damaged or faulty, the set lamp/auto headlamp ambient light sensor unit must be replaced.

DIAGNOSIS AND TESTING**VEHICLE THEFT SECURITY SYSTEM**

WARNING: ON VEHICLES EQUIPPED WITH AIRBAGS, REFER TO GROUP 8M - PASSIVE RESTRAINT SYSTEMS BEFORE ATTEMPTING ANY STEERING WHEEL, STEERING COLUMN, OR INSTRUMENT PANEL COMPONENT DIAGNOSIS OR SERVICE. FAILURE TO TAKE THE PROPER PRECAUTIONS COULD RESULT IN ACCIDENTAL AIRBAG DEPLOYMENT AND POSSIBLE PERSONAL INJURY.

The Vehicle Theft Security System (VTSS) and the Chrysler Collision Detection (CCD) data bus network should be diagnosed using the DRB scan tool and the proper Diagnostic Procedures manual. The DRB scan tool will provide confirmation that the CCD data bus is functional, that the Body Control Module (BCM) is enabled and putting the proper messages on the CCD data bus, that the BCM is enabled and receiving the proper hard-wired inputs and sending the proper hard-wired outputs, and that the Powertrain Control Module (PCM) is enabled and receiving the CCD data bus messages from the BCM.

Refer to the proper Diagnostic Procedures manual and the Vehicle Theft Security System menu item on the DRB scan tool for the procedures. Refer to 8W-39 - Vehicle Theft Security System in Group 8W - Wiring Diagrams for complete circuit descriptions and diagrams.

RELAYS

The horn relay is located in the Power Distribution Center (PDC) in the engine compartment. The auto headlamp and park lamp relays are located in the junction block in the passenger compartment. Each

of these relays (Fig. 1) can be tested as described in the following procedure, however the circuits they are used in do vary. To test the relay circuits, refer to the circuit descriptions and diagrams in 8W-39 - Vehicle Theft Security System in Group 8W - Wiring Diagrams.

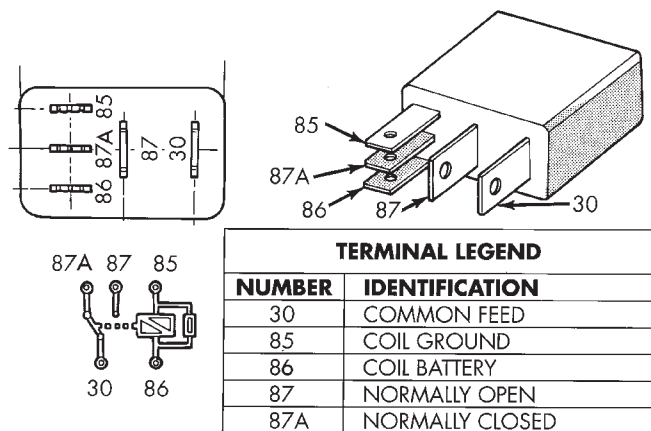
WARNING: ON VEHICLES EQUIPPED WITH AIRBAGS, REFER TO GROUP 8M - PASSIVE RESTRAINT SYSTEMS BEFORE ATTEMPTING ANY STEERING WHEEL, STEERING COLUMN, OR INSTRUMENT PANEL COMPONENT DIAGNOSIS OR SERVICE. FAILURE TO TAKE THE PROPER PRECAUTIONS COULD RESULT IN ACCIDENTAL AIRBAG DEPLOYMENT AND POSSIBLE PERSONAL INJURY.

Remove the relay from the PDC or junction block as described in this group to perform the following tests:

(1) A relay in the de-energized position should have continuity between terminals 87A and 30, and no continuity between terminals 87 and 30. If OK, go to Step 2. If not OK, replace the faulty relay.

(2) Resistance between terminals 85 and 86 (electromagnet) should be 75 ± 5 ohms. If OK, go to Step 3. If not OK, replace the faulty relay.

(3) Connect a battery to terminals 85 and 86. There should now be continuity between terminals 30 and 87, and no continuity between terminals 87A and 30. If OK, test the relay circuits. If not OK, replace the faulty relay.



9514-16

Fig. 1 Relay Terminals

REMOVAL AND INSTALLATION

DOOR AJAR SWITCH

- (1) Disconnect and isolate the battery negative cable.
- (2) Remove the screw that secures the door ajar switch to the pillar at the rear of the door opening (Fig. 2).

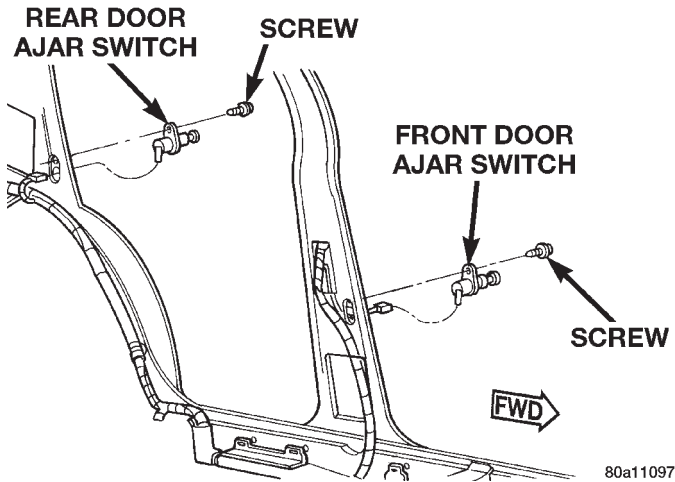


Fig. 2 Door Ajar Switch Remove/Install

- (3) Pull the switch out from the mounting hole in the door opening far enough to access the wire harness connector.
- (4) Unplug the wire harness connector from the switch.
- (5) Reverse the removal procedures to install. Tighten the switch mounting screw to 1.7 N·m (15 in. lbs.).

DOOR LOCK CYLINDER SWITCH

- (1) Disconnect and isolate the battery negative cable.
- (2) Remove the bezel near the inside door latch release handle by inserting a straight-bladed screwdriver in the notched end of the bezel and prying gently upwards.
- (3) Remove the screw located beneath the bezel that secures the front door trim panel to the inner door panel (Fig. 3).
- (4) Remove the trim cap and screw near the rear of the front door armrest.
- (5) Remove the trim cap and screw at the upper front corner of the front door trim panel.
- (6) Remove the screw located above the front door speaker grille on the front door trim panel.

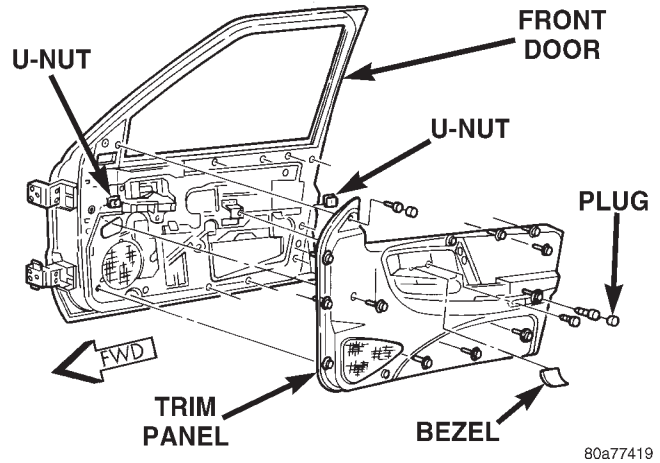


Fig. 3 Front Door Trim Panel Remove/Install

- (7) Using a trim stick or another suitable wide flat-bladed tool, gently pry the front door trim panel away from the door around the perimeter to release the trim panel retainers.

NOTE: To aid in the removal of the trim panel, start at the bottom of the panel.

- (8) Pull the front door trim panel away from the inner door panel far enough to access and unplug the wire harness connectors from the door module and, if the vehicle is so equipped, from the front door courtesy lamp.
- (9) Pull the watershield away from the rear access holes in the front door inner panel.
- (10) Remove the U-clip retainer that secures the lock cylinder to the outer door panel (Fig. 4).

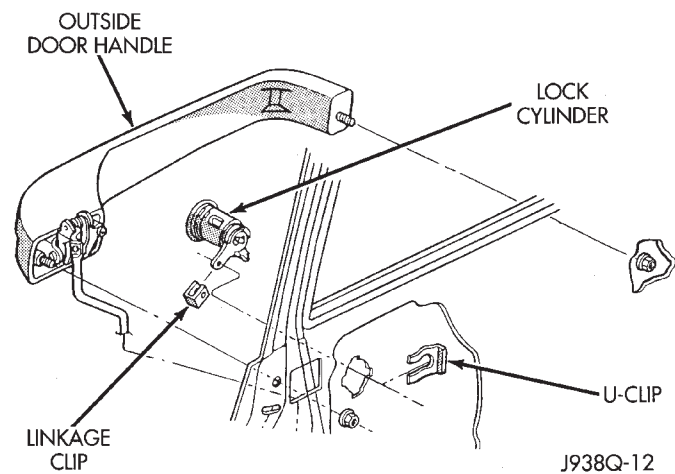


Fig. 4 Door Lock Cylinder Remove/Install

- (11) Disconnect the door lock cylinder actuator rod from the door latch by unsnapping the plastic retainer.

REMOVAL AND INSTALLATION (Continued)

(12) Pull the lock cylinder out of its mounting hole from the outside of the door panel far enough to pry the lock cylinder switch off of the back of the lock cylinder (Fig. 5).

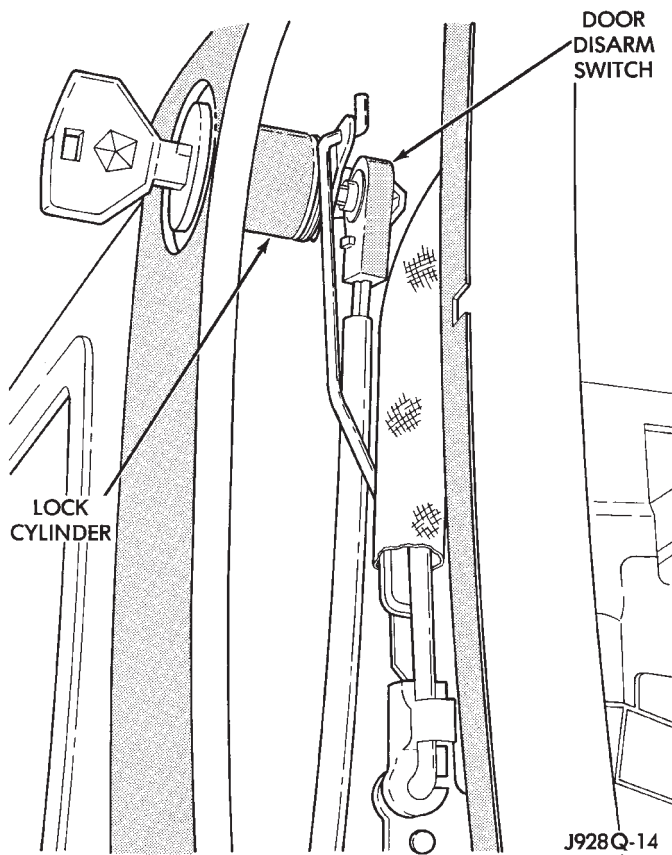


Fig. 5 Door Lock Cylinder Switch Remove/Install - Typical

(13) From the inside of the door unplug the lock cylinder switch wire harness connector and remove the switch from the door.

(14) Reverse the removal procedures to install. Tighten the mounting screws to 2.2 N·m (20 in. lbs.).

LIFTGATE AJAR SWITCH

(1) Disconnect and isolate the battery negative cable.

(2) Open the liftgate.

(3) Remove the screws that secure the liftgate lower trim panel to the liftgate inner panel (Fig. 6).

(4) Using a trim stick or another suitable wide flat-bladed tool, gently pry the perimeter edges of the trim panel away from the liftgate inner panel to release the retainers.

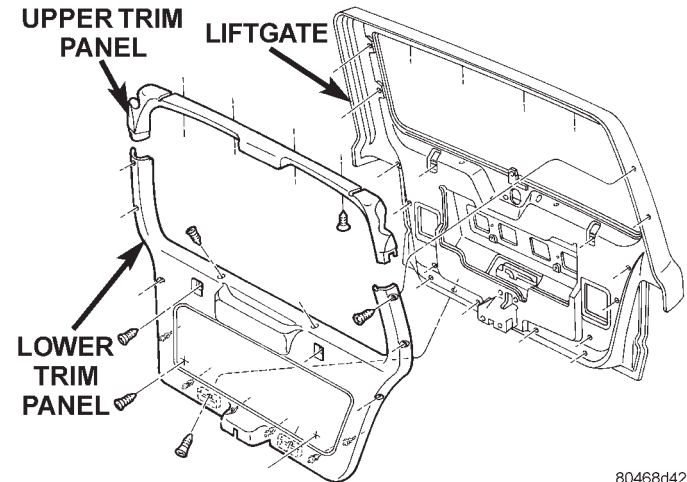


Fig. 6 Liftgate Trim Panel Remove/Install

NOTE: To aid in the removal of the trim panel, start at the bottom of the panel.

(5) Remove the liftgate trim panel from the vehicle.

(6) Remove the three screws that secure the liftgate latch to the liftgate (Fig. 7).

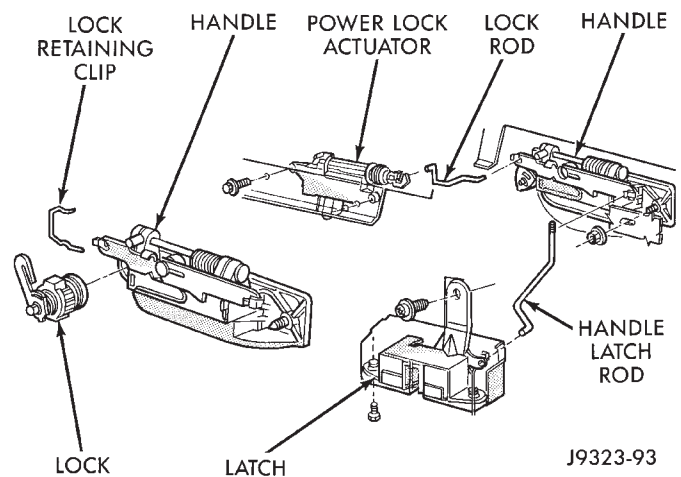


Fig. 7 Liftgate Latch/Lock Components

(7) Disconnect the liftgate handle latch actuator rod from the latch.

(8) Unplug the liftgate ajar switch wire harness connector from the latch.

(9) Remove the latch from the liftgate.

(10) Reverse the removal procedures to install. Tighten the latch mounting screws to 7 N·m (62 in. lbs.).

REMOVAL AND INSTALLATION (Continued)

LIFTGATE LOCK CYLINDER SWITCH

- (1) Disconnect and isolate the battery negative cable.
- (2) Open the liftgate.
- (3) Remove the screws that secure the liftgate lower trim panel to the liftgate inner panel (Fig. 8).

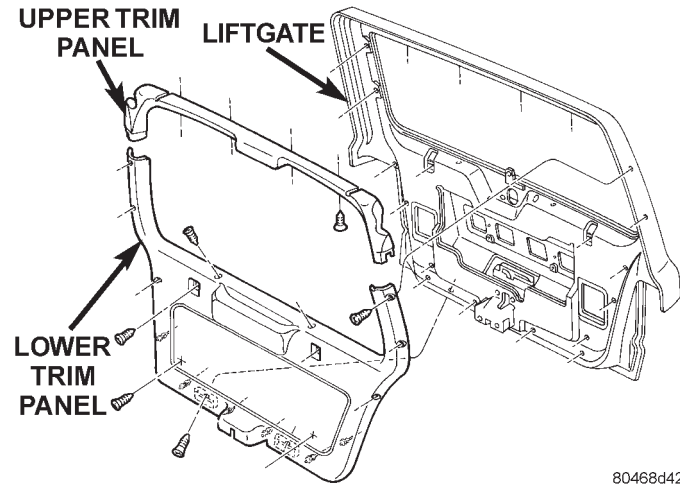


Fig. 8 Liftgate Trim Panel Remove/Install

- (4) Using a trim stick or another suitable wide flat-bladed tool, gently pry the perimeter edges of the trim panel away from the liftgate inner panel to release the retainers.

NOTE: To aid in the removal of the trim panel, start at the bottom of the panel.

- (5) Remove the lower liftgate trim panel from the vehicle.
- (6) Pry the liftgate lock cylinder switch off the back of the lock cylinder (Fig. 9).
- (7) Unplug the lock cylinder switch wire harness connector and remove the switch from inside the liftgate.

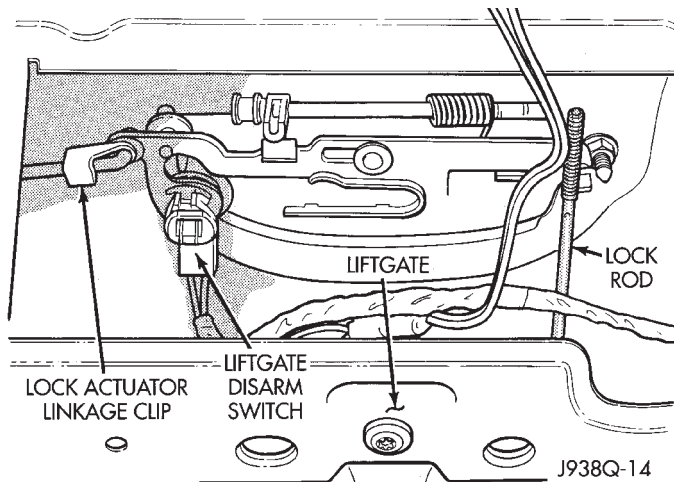


Fig. 9 Liftgate Lock Cylinder Switch Remove/Install

- (8) Reverse the removal procedures to install. Tighten the mounting screws to 2.2 N-m (20 in. lbs.).

LIFTGLASS AJAR SWITCH

- (1) Disconnect and isolate the battery negative cable.
- (2) Open the liftgate.
- (3) Remove the screws that secure the liftgate lower trim panel to the liftgate inner panel (Fig. 10).

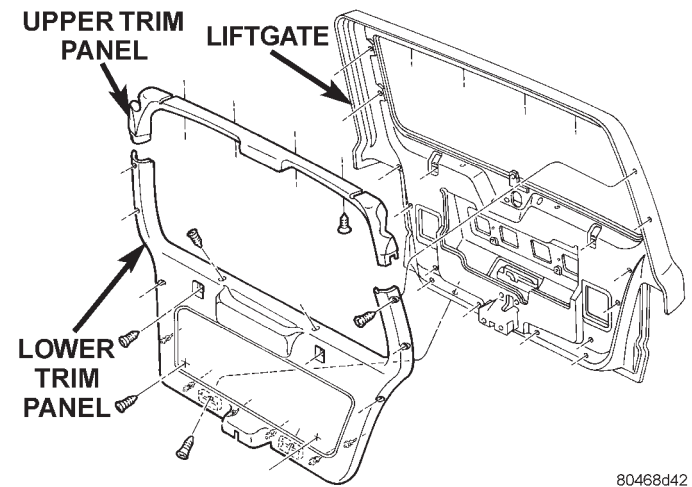


Fig. 10 Liftgate Trim Panel Remove/Install

- (4) Using a trim stick or another suitable wide flat-bladed tool, gently pry the perimeter edges of the trim panel away from the liftgate inner panel to release the retainers.

NOTE: To aid in the removal of the trim panel, start at the bottom of the panel.

- (5) Remove the lower liftgate trim panel from the vehicle.
- (6) Remove the two nuts that secure the liftglass latch to the liftgate inner panel (Fig. 11).

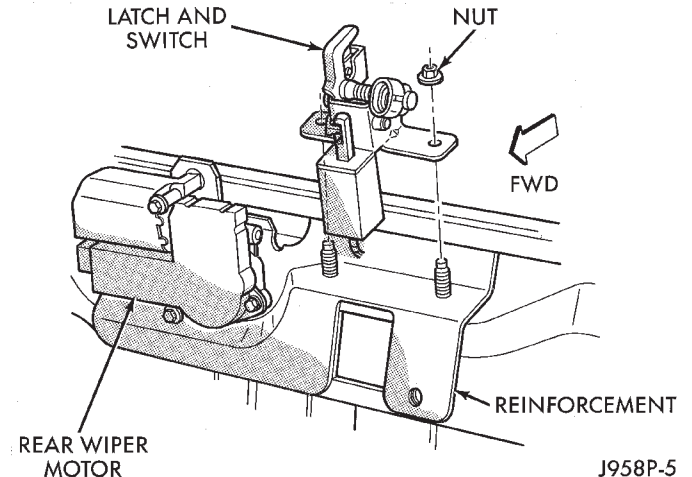


Fig. 11 Liftglass Ajar Switch Remove/Install

REMOVAL AND INSTALLATION (Continued)

- (7) Unplug the wire harness connectors for the liftglass latch solenoid and the liftglass ajar switch.
- (8) Remove the liftglass latch from the liftgate.
- (9) Reverse the removal procedures to install. Tighten the latch mounting nuts to 11 N·m (100 in. lbs.). Tighten the trim panel mounting screws to 2.2 N·m (20 in. lbs.).

AUTO HEADLAMP AND PARK LAMP RELAYS

WARNING: ON VEHICLES EQUIPPED WITH AIR-BAGS, REFER TO GROUP 8M - PASSIVE RESTRAINT SYSTEMS BEFORE ATTEMPTING ANY STEERING WHEEL, STEERING COLUMN, OR INSTRUMENT PANEL COMPONENT DIAGNOSIS OR SERVICE. FAILURE TO TAKE THE PROPER PRECAUTIONS COULD RESULT IN ACCIDENTAL AIR-BAG DEPLOYMENT AND POSSIBLE PERSONAL INJURY.

- (1) Disconnect and isolate the battery negative cable.
- (2) Remove the fuse access panel by unsnapping it from the right cowl side trim panel.
- (3) Remove the push nut that secures the right cowl side trim panel to the junction block stud (Fig. 12).

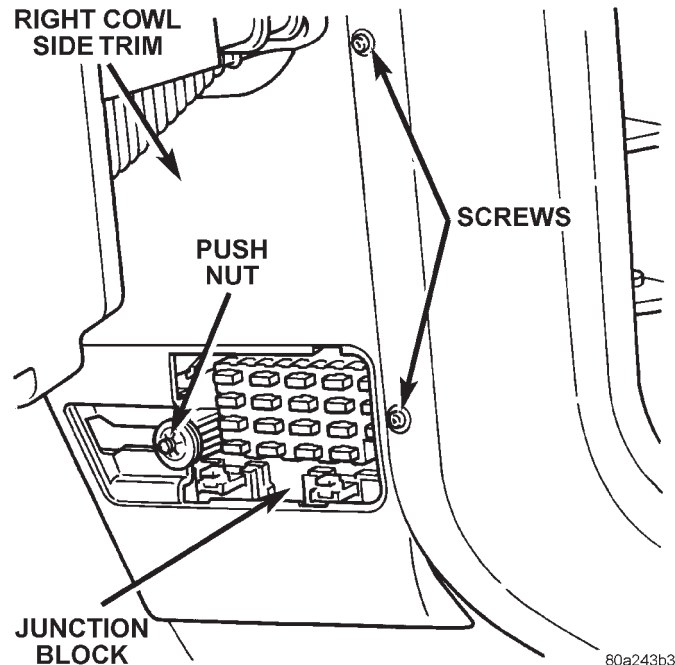


Fig. 12 Right Cowl Side Trim Remove/Install

- (4) Remove the two screws that secure the right cowl side trim panel to the right front door opening trim.
- (5) Remove the right cowl side trim panel from the right cowl side inner panel.

- (6) Unplug the headlamp or park lamp relay from the junction block.
- (7) Install the headlamp or park lamp relay by aligning the relay terminals with the cavities in the junction block and pushing the relay firmly into place.
- (8) Connect the battery negative cable.
- (9) Test the relay operation.
- (10) Reinstall the right cowl side trim and the fuse access panel.

HORN RELAY

- (1) Disconnect and isolate the battery negative cable.
- (2) Remove the cover from the Power Distribution Center (PDC) (Fig. 13).

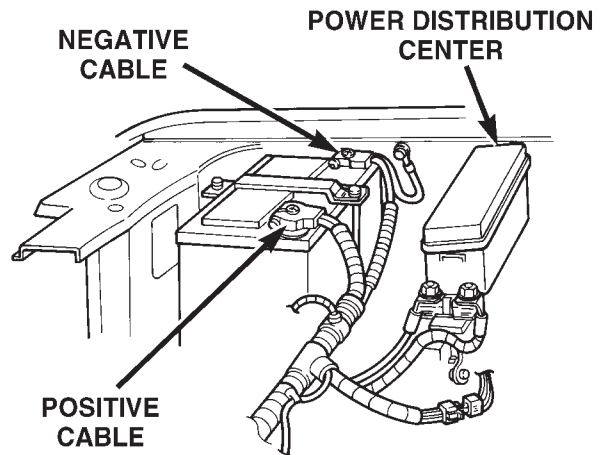


Fig. 13 Power Distribution Center

- (3) Refer to the label on the PDC for horn relay identification and location.
- (4) Unplug the horn relay from the PDC.
- (5) Install the horn relay by aligning the relay terminals with the cavities in the PDC and pushing the relay firmly into place.
- (6) Install the PDC cover.
- (7) Connect the battery negative cable.
- (8) Test the relay operation.

SET LAMP

WARNING: ON VEHICLES EQUIPPED WITH AIR-BAGS, REFER TO GROUP 8M - PASSIVE RESTRAINT SYSTEMS BEFORE ATTEMPTING ANY STEERING WHEEL, STEERING COLUMN, OR INSTRUMENT PANEL COMPONENT DIAGNOSIS OR SERVICE. FAILURE TO TAKE THE PROPER PRECAUTIONS COULD RESULT IN ACCIDENTAL AIR-BAG DEPLOYMENT AND POSSIBLE PERSONAL INJURY.

REMOVAL AND INSTALLATION (Continued)

(1) Disconnect and isolate the battery negative cable.

(2) Using a trim stick or another suitable wide flat-bladed tool, gently pry the cowl top trim panel off of the instrument panel top pad (Fig. 14).

(3) Pull the trim panel up far enough to access and unplug the wire harness connector for the solar sensor, or to remove the solar sensor from the cowl top trim, if the vehicle is so equipped.

(4) Remove the cowl top trim panel from the instrument panel.

(5) Remove the auto headlamp light sensor/vehicle theft security system set lamp mounting screw near the driver side defroster duct outlet.

(6) Pull the set lamp up from the top of the instrument panel far enough to access and unplug the wire harness connector.

(7) remove the set lamp from the instrument panel.

(8) Reverse the removal procedures to install. Tighten the mounting screw to 2.2 N·m (20 in. lbs.).

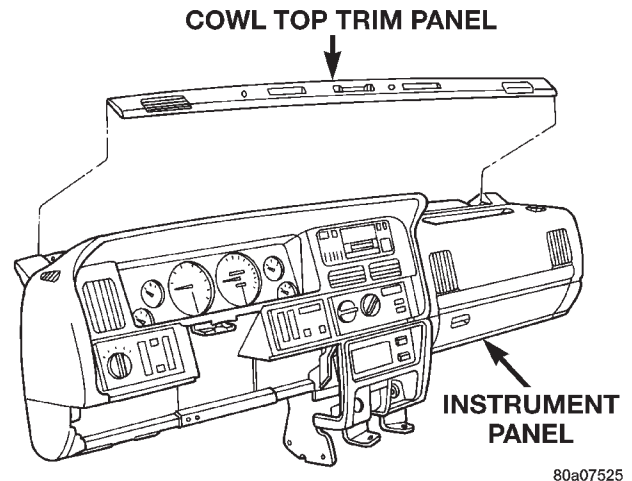


Fig. 14 Cowl Top Trim Remove/Install

VEHICLE THEFT/SECURITY SYSTEMS

CONTENTS

	page		page
GENERAL INFORMATION		POWER-UP MODE	5
ARMING	1	SET LAMP	3
DISARMING	2	DIAGNOSIS AND TESTING	
INTRODUCTION	1	RELAYS	5
POWER-UP MODE	2	VEHICLE THEFT SECURITY SYSTEM	5
TAMPER ALERT	2	SERVICE PROCEDURES	
DESCRIPTION AND OPERATION		ENABLING	6
AUTO HEADLAMP RELAY	3	VEHICLE IMMOBILIZER SYSTEM	5
BODY CONTROL MODULE	2	REMOVAL AND INSTALLATION	
DOOR AJAR SWITCH	2	AUTO HEADLAMP AND PARK LAMP RELAYS	10
DOOR LOCK CYLINDER SWITCH	2	DOOR AJAR SWITCH	7
HOOD SWITCH	2	DOOR LOCK CYLINDER SWITCH	8
HORN RELAY	3	HOOD SWITCH	7
IMMOBILIZER RECEIVER	4	HORN RELAY	10
IMMOBILIZER SYSTEM	3	IMMOBILIZER RECEIVER	6
IMMOBILIZER TRANSMITTER	4	LIFTGATE AJAR SWITCH	9
LIFTGATE AJAR SWITCH	3	LIFTGATE LOCK CYLINDER SWITCH	9
LIFTGATE LOCK CYLINDER SWITCH	3	LIFTGLASS AJAR SWITCH	9
LIFTGLASS AJAR SWITCH	3	SET LAMP	11
PARK LAMP RELAY	3		

GENERAL INFORMATION

INTRODUCTION

The Vehicle Theft Security System (VTSS) is an available factory-installed option on this model. This system is designed to provide perimeter protection against unauthorized use or tampering by monitoring the vehicle doors, hood, liftgate, and ignition system. If unauthorized use or tampering is detected, the system responds by sounding the horn, flashing the exterior lamps, and providing an engine no-run feature.

Following are some general descriptions of the features of the VTSS. Refer to the vehicle owner's manual for additional information. Refer to 8W-39 - Vehicle Theft Security System in Group 8W - Wiring Diagrams for complete circuit descriptions and diagrams.

NOTE: This group covers both Left-Hand Drive (LHD) and Right-Hand Drive (RHD) versions of this model. Whenever required and feasible, the RHD versions of affected vehicle components have been constructed as mirror-image of the LHD versions. While most of the illustrations used in this group represent only the LHD version, the diagnostic and service procedures outlined can generally be applied to either version. Exceptions to this rule have been clearly identified as LHD or RHD, if a special illustration or procedure is required.

ARMING

Passive arming of the VTSS occurs when the vehicle is exited with the key removed from the ignition switch, the headlamps are turned off, and the doors are locked using the power lock switch. The power lock switch will not function if the key is in the ignition switch or the headlamps are on with the driver's door open. The VTSS will not arm if either front door or the liftgate are locked using the key in the lock cylinder.

Active arming of the VTSS occurs when the Remote Keyless Entry (RKE) transmitter is used to lock the vehicle, even if the doors and/or the liftgate are open when the RKE transmitter Lock button is depressed. However, the VTSS arming will not be complete until all the doors and the liftgate are closed.

Following successful passive or active VTSS arming, the VTSS set lamp on the top of the instrument panel will flash rapidly for about 15 seconds after the illuminated entry system times out. This indicates that VTSS arming is in progress. If the light stays on steadily during the arming, it indicates that the hood switch is closed (the hood is open). The VTSS will still arm if the hood is open, but the engine compartment will not be protected. Once the 15 second arming function is complete, the set lamp will flash at a slower rate to indicate that the VTSS is armed.

GENERAL INFORMATION (Continued)

DISARMING

Passive disarming of the VTSS occurs when the vehicle is unlocked using the key to unlock either front door or the liftgate. Active disarming of the VTSS occurs when the vehicle is unlocked by depressing the Unlock button of the RKE transmitter.

Once the alarm has been activated (horn sounding, lights flashing, and the engine no-run feature), either disarming method will also deactivate the alarm.

Depressing the Panic button on the RKE transmitter will also disarm the VTSS, but the horn will sound and the lights will flash for about three minutes as part of the Panic feature. Refer to Group 8P - Power Lock Systems for more information on the Panic feature.

POWER-UP MODE

When the armed VTSS senses that the battery has been disconnected and reconnected, it enters its power-up mode. In the power-up mode the alarm system remains armed following a battery failure or disconnect. If the VTSS was armed prior to a battery disconnect or failure, the system will have to be actively or passively disarmed following a battery reconnection.

The power-up mode will also apply if the battery goes dead while the system is armed, and battery jump-starting is attempted. The engine no-run feature will prevent the engine from starting until the alarm system has been actively or passively disarmed.

TAMPER ALERT

The Vehicle Theft Security System (VTSS) tamper alert will sound the horn three times upon disarming, if the alarm was activated and has since timed-out (about eighteen minutes). This feature alerts the vehicle operator that the VTSS was activated while the vehicle was unattended.

DESCRIPTION AND OPERATION

BODY CONTROL MODULE

A Body Control Module (BCM) is used on this model to control and integrate many of the electronic functions and features included on the vehicle. The BCM contains a central processing unit and interfaces with other modules in the vehicle on the Chrysler Collision Detection (CCD) data bus network.

The CCD data bus network allows the sharing of sensor information. This helps to reduce wire harness complexity, reduce internal controller hardware, and reduce component sensor current loads. At the same time, this system provides increased reliability,

enhanced diagnostics, and allows the addition of many new feature capabilities.

One of the functions and features that the BCM supports and controls, is the Vehicle Theft Security System (VTSS). In the VTSS, the BCM receives CCD message inputs from the Passenger Door Module (PDM), which contains the Remote Keyless Entry (RKE) receiver. In addition to the information received on the CCD data bus, the BCM receives hard-wired inputs from the door ajar, door lock cylinder, ignition, liftgate ajar, liftgate lock cylinder, and liftglass ajar switches. The programming in the BCM allows it to process the information from all of its inputs and send control outputs to energize or de-energize the auto headlamp relay, horn relay, park lamp relay, Powertrain Control Module (PCM), and the security set lamp.

The BCM is mounted under the driver side outboard end of the instrument panel, behind the instrument panel support armature and below the outboard switch pod. Refer to Group 8E - Instrument Panel Systems for the removal and installation procedures. For diagnosis of the BCM or the CCD data bus, the use of a DRB scan tool and the proper Diagnostic Procedures manual are recommended. The BCM can only be serviced by an authorized electronic repair station. Refer to the latest Warranty Policies and Procedures manual for a current listing of authorized electronic repair stations.

HOOD SWITCH

The hood switch is mounted to the right inner fender ledge, under the hood and near the battery. It is a plunger-type switch that is case grounded to the fender shield. When the hood is open the switch is closed, and when the hood is closed the switch is open.

The hood switch cannot be repaired and, if faulty or damaged, it must be replaced.

DOOR AJAR SWITCH

The door ajar switches are mounted to the pillar in the rear of each door opening. They are plunger-type switches that are case grounded to the pillar. When the door is open the switch is closed, and when the door is closed the switch is open.

The door ajar switches cannot be repaired and, if faulty or damaged, they must be replaced.

DOOR LOCK CYLINDER SWITCH

The door lock cylinder switches are mounted to the back of the key lock cylinder inside each front door. They are normally-open momentary switches that close to ground only when the lock cylinder is rotated to the unlock position.

DESCRIPTION AND OPERATION (Continued)

The door lock cylinder switches cannot be repaired and, if faulty or damaged, they must be replaced.

LIFTGATE AJAR SWITCH

The liftgate ajar switch is integral to the liftgate latch assembly on the liftgate. It is a momentary-type switch that is open when the liftgate is closed, and closed when the liftgate is open.

The liftgate ajar switch cannot be repaired and, if faulty or damaged, the liftgate latch assembly must be replaced.

LIFTGATE LOCK CYLINDER SWITCH

The liftgate lock cylinder switch is mounted to the back of the key lock cylinder inside the liftgate. It is a normally-open momentary switch that closes to ground only when the lock cylinder is rotated to the unlock position.

The liftgate lock cylinder switch cannot be repaired and, if faulty or damaged, it must be replaced.

LIFTGLASS AJAR SWITCH

The liftglass ajar switch is integral to the liftglass latch assembly on the liftgate. It is a momentary-type switch that is open when the liftglass is closed, and closed when the liftglass is open.

The liftglass ajar switch cannot be repaired and, if faulty or damaged, the liftglass latch assembly must be replaced.

AUTO HEADLAMP RELAY

The auto headlamp relay is a International Standards Organization (ISO) micro-relay. The terminal designations and functions are the same as a conventional ISO relay. However, the micro-relay terminal orientation (or footprint) is different, current capacity is lower, and the relay case dimensions are smaller than those of the conventional ISO relay.

The auto headlamp relay is a electromechanical device that switches battery current to the headlamps when the Body Control Module (BCM) grounds the relay coil. See Auto Headlamp Relay in the Diagnosis and Testing section of this group for more information.

The auto headlamp relay is located in the junction block, on the right cowl side inner panel below the instrument panel in the passenger compartment.

The auto headlamp relay cannot be repaired and, if faulty or damaged, it must be replaced.

HORN RELAY

The horn relay is a International Standards Organization (ISO) micro-relay. The terminal designations and functions are the same as a conventional ISO relay. However, the micro-relay terminal orientation (or footprint) is different, current capacity is lower,

and the relay case dimensions are smaller than those of the conventional ISO relay.

The horn relay is a electromechanical device that switches battery current to the horn when the horn switch or the Body Control Module (BCM) grounds the relay coil. See Horn Relay in the Diagnosis and Testing section of this group for more information.

The horn relay is located in the Power Distribution Center (PDC), in the engine compartment. Refer to the PDC label for relay identification and location.

If a problem is encountered with a continuously sounding horn, it can usually be quickly resolved by removing the horn relay from PDC until further diagnosis is completed.

The horn relay cannot be repaired and, if faulty or damaged, it must be replaced.

PARK LAMP RELAY

The park lamp relay is a International Standards Organization (ISO) micro-relay. The terminal designations and functions are the same as a conventional ISO relay. However, the micro-relay terminal orientation (or footprint) is different, current capacity is lower, and the relay case dimensions are smaller than those of the conventional ISO relay.

The park lamp relay is a electromechanical device that switches battery current to the park lamps when the Body Control Module (BCM) grounds the relay coil. See Park Lamp Relay in the Diagnosis and Testing section of this group for more information.

The park lamp relay is located in the junction block, on the right cowl side panel below the instrument panel in the passenger compartment. The park lamp relay can be accessed by removing the fuse access panel and the right cowl side trim panel.

The park lamp relay cannot be repaired and, if faulty or damaged, it must be replaced.

SET LAMP

The VTSS set lamp is a red light-emitting diode mounted with the auto headlamp ambient light sensor on top of the instrument panel near the driver's side defroster outlet. The set lamp receives fused battery feed at all times and is grounded by the body control module to give a visible indication of the VTSS status.

The set lamp cannot be repaired and, if damaged or faulty, the set lamp/auto headlamp ambient light sensor must be replaced as a unit.

IMMOBILIZER SYSTEM

The Immobilizer System prevents unauthorized operation of the vehicle by disabling the engine. The system will NOT allow the vehicle to start unless the UNLOCK button on the RKE transmitter is pressed. The system will be activated after turning the igni-

DESCRIPTION AND OPERATION (Continued)

tion switch to the OFF position and using one of the following methods.

(1) Press the LOCK button on the RKE transmitter.

(2) LOCK the doors by pressing a power lock button switch.

(3) LOCK the driver or passenger door using the key.

- The Security light will flash, for about 16 seconds, indicating that the engine will be disabled.

- The Security light remaining on, indicates the system is not operational.

- The Immobilizer will activate automatically within 10 minutes of the ignition switch being in the OFF position, whether the vehicle has been locked or unlocked.

- An attempt to start the vehicle without pressing the UNLOCK button on the RKE transmitter will result in a warning chime and the Security light flashing.

NOTE: The ignition switch must be in the OFF position in order for the system to be activated, whether the doors are closed or not.

IMMOBILIZER RECEIVER

The immobilizer receiver is programmed to respond to the Lock and Unlock radio signals issued by the immobilizer transmitters. The receiver will only respond to the radio signals of transmitters (up to four) whose vehicle access codes have been stored in the receiver's electronic memory. The receiver is programmed at the assembly plant with the vehicle access codes of the two transmitters that are shipped with the vehicle.

The immobilizer receiver also has a central processing unit, which contains the immobilizer system logic. The programming in the immobilizer receiver allows the system to learn and retain transmitter vehicle access codes, as well as to communicate with the Powertrain Control Module (PCM) and/or the DRB scan tool on the Chrysler Collision Detection (CCD) data bus network.

The CCD data bus network allows the sharing of sensor information. This helps to reduce wiring harness complexity, reduce internal controller hardware, and reduce component sensor current loads. At the same time, the CCD data bus network provides increased reliability and enhanced diagnostic capabilities.

Each immobilizer transmitter has a different vehicle access code, which must be programmed into the memory of the immobilizer receiver in the vehicle in order to operate the immobilizer system. A DRB scan tool must be used to program new or additional transmitter vehicle access codes into the memory of

the immobilizer receiver. Refer to the Vehicle Theft Security System menu item on the DRB scan tool for the procedures.

The immobilizer receiver recognizes the Lock and Unlock signals received from the programmed immobilizer transmitters. The receiver then uses the programmed immobilizer system logic to decide whether other monitored conditions are proper for an engine Lock or Unlock message to be sent. If the programmed conditions are met, the receiver responds by sending the proper message to the PCM on the CCD data bus. The PCM responds to the message by disabling or enabling the fuel injector driver circuitry within the PCM, which will inhibit engine operation.

The immobilizer receiver is mounted to the dash panel with a hook and loop fastener patch. It is located behind the instrument cluster and above the driver side end of the heater-A/C housing. The receiver is connected to the dash panel cross-body wiring harness.

For diagnosis of the vehicle immobilizer receiver or the CCD data bus, a DRB scan tool is required. Refer to the Vehicle Theft Security System menu item of the DRB scan tool for the procedures. The immobilizer receiver cannot be repaired and, if faulty, the unit must be replaced.

IMMOBILIZER TRANSMITTER

The vehicle immobilizer system includes two transmitters that are supplied with the vehicle when it is shipped from the factory. Each of the two transmitters is equipped with two buttons labeled with International Standards Organization (ISO) symbols for Lock, and Unlock. Two spare batteries (enough for one transmitter) are also shipped with the transmitters. The transmitters are equipped with a key ring and are designed to serve as a key fob. The operating range of the radio frequency transmitter signal is up to 7 meters (23 feet) from the immobilizer receiver.

Each transmitter has a different vehicle access code, which must be programmed into the memory of the immobilizer receiver in the vehicle in order to operate the immobilizer system. The two transmitters shipped with the vehicle have their vehicle access codes programmed into the receiver at the factory. A DRB scan tool must be used to program new or additional transmitter vehicle access codes into the memory of the immobilizer receiver. Refer to the Vehicle Theft Security System menu item on the DRB scan tool for the procedures.

Each transmitter operates on two Duracell DL2016 (or equivalent) batteries. Typical battery life is from one to two years.

DESCRIPTION AND OPERATION (Continued)

POWER-UP MODE

When the vehicle immobilizer system senses that the vehicle battery has been disconnected and reconnected, it enters its power-up mode. If the immobilizer system was armed prior to the battery disconnect, the system remains armed when the battery is reconnected.

If the immobilizer system was disarmed prior to the battery disconnect, the system will remain disarmed if the battery is reconnected within five minutes. The system will passively arm itself when the battery is reconnected more than five minutes after a battery disconnect or failure. After any passive arming, the system will have to be actively disarmed using one of the transmitters.

The power-up mode logic also applies if the battery goes dead, and battery jump-starting is attempted. The engine no-run feature will prevent the engine from operating until the vehicle immobilizer system has been actively disarmed.

DIAGNOSIS AND TESTING

VEHICLE THEFT SECURITY SYSTEM

The vehicle theft security system should be diagnosed using the DRB scan tool and the proper Body Diagnostic Procedures Manual. Refer to 8W-39 - Vehicle Theft Security System in Group 8W - Wiring Diagrams for complete circuit descriptions and diagrams.

Self-Diagnostics

The vehicle theft security system has a self-diagnostic mode that can be entered using the DRB scan tool. Refer to the proper Body Diagnostic Procedures Manual for more information on this feature.

RELAYS

The horn relay is located in the Power Distribution Center (PDC) in the engine compartment. The auto headlamp and park lamp relays are located in the junction block in the passenger compartment. Each of these relays (Fig. 1) can be tested as described in the following procedure, however the circuits they are used in do vary. To test the relay circuits, refer to the circuit descriptions and diagrams in 8W-39 - Vehicle Theft Security System in Group 8W - Wiring Diagrams.

WARNING: ON VEHICLES EQUIPPED WITH AIR-BAGS, REFER TO GROUP 8M - PASSIVE RESTRAINT SYSTEMS BEFORE ATTEMPTING ANY STEERING WHEEL, STEERING COLUMN, OR INSTRUMENT PANEL COMPONENT DIAGNOSIS OR SERVICE. FAILURE TO TAKE THE PROPER PRECAUTIONS COULD RESULT IN ACCIDENTAL AIR-

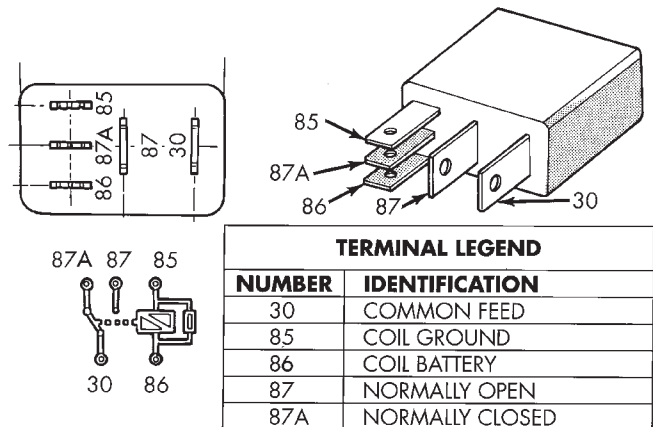
BAG DEPLOYMENT AND POSSIBLE PERSONAL INJURY.

Remove the relay from the PDC or junction block as described in this group to perform the following tests:

(1) A relay in the de-energized position should have continuity between terminals 87A and 30, and no continuity between terminals 87 and 30. If OK, go to Step 3. If not OK, replace the faulty relay.

(2) Resistance between terminals 85 and 86 (electromagnet) should be 75 ± 5 ohms. If OK, go to Step 4. If not OK, replace the faulty relay.

(3) Connect a battery to terminals 85 and 86. There should now be continuity between terminals 30 and 87, and no continuity between terminals 87A and 30. If OK, test the relay circuits. If not OK, replace the faulty relay.



9514-16

Fig. 1 Relay Terminals

SERVICE PROCEDURES

VEHICLE IMMOBILIZER SYSTEM

WARNING: ON VEHICLES EQUIPPED WITH AIR-BAGS, REFER TO GROUP 8M - PASSIVE RESTRAINT SYSTEMS BEFORE ATTEMPTING ANY STEERING WHEEL, STEERING COLUMN, OR INSTRUMENT PANEL COMPONENT DIAGNOSIS OR SERVICE. FAILURE TO TAKE THE PROPER PRECAUTIONS COULD RESULT IN ACCIDENTAL AIR-BAG DEPLOYMENT AND POSSIBLE PERSONAL INJURY.

SERVICE PROCEDURES (Continued)

NOTE: The following tests may not prove conclusive in the diagnosis of this system. The most reliable, efficient, and accurate means to diagnose the Vehicle Immobilizer System involves the use of a DRB scan tool. Refer to the Vehicle Theft Security System menu item on the DRB scan tool for the procedures.

The vehicle immobilizer system and the Chrysler Collision Detection (CCD) data bus network should be diagnosed using the DRB scan tool. The DRB will allow confirmation that the CCD data bus is functional, that the immobilizer receiver is placing the proper messages on the CCD data bus, and that the Powertrain Control Module (PCM) is receiving the CCD data bus messages. Refer to the Vehicle Theft Security System menu item on the DRB scan tool for the procedures. Refer to 8W-39 - Vehicle Theft Security System in Group 8W - Wiring Diagrams for complete circuit descriptions and diagrams.

(1) With the ignition switch in the Off position, depress the Lock or Unlock button of the immobilizer transmitter. Listen for the immobilizer receiver to issue an audible chirp (Unlock) or chirps (Lock). If OK, go to Step 3. If not OK, replace the transmitter batteries with known good units and repeat Step 2. If still not OK, go to Step 3.

(2) Check the fuse in the Power Distribution Center (PDC). If OK, go to Step 4. If not OK, repair the shorted circuit or component as required and replace the faulty fuse.

(3) Disconnect and isolate the battery negative cable. Unplug the wire harness connector at the immobilizer receiver. Check for continuity between the ground circuit cavity of the immobilizer receiver wire harness connector and a good ground. There should be continuity. If OK, go to Step 5. If not OK, repair the open circuit to ground as required.

(4) Connect the battery negative cable. Check for battery voltage at the fused B(+) circuit cavity of the immobilizer receiver wire harness connector. If OK, refer to the Vehicle Theft Security System menu item on the DRB scan tool for further diagnosis. If not OK, repair the open circuit to the PDC fuse as required.

ENABLING

The vehicle immobilizer system is disabled when it is shipped from the factory. This is done by programming within the Powertrain Control Module (PCM). The logic in the PCM prevents the immobilizer system from arming until the engine start counter within the PCM sees twenty engine starts. The system must be enabled when the vehicle is received from the assembly plant.

The preferred method for enabling the immobilizer system is to electronically advance the PCM engine

start counter using a DRB scan tool. Refer to the Vehicle Theft Security System menu item on the DRB scan tool for the procedures. Once this condition has been met, the PCM will allow the immobilizer system to arm.

If a DRB scan tool is not available, the immobilizer system can be enabled manually, as follows:

(1) If five minutes or more have elapsed since the last previous engine start, or if the vehicle immobilizer receiver has been actively armed, depress the vehicle immobilizer transmitter Unlock button. Listen for a single audible chirp from the immobilizer receiver to confirm the Unlock message has been received.

(2) Start the engine. Each engine start must be followed by a minimum engine run duration of ten seconds.

(3) Allowing a cool-down period between starts, go back to Step 2 a total of twenty times. After twenty cycles, confirm that the vehicle immobilizer system is enabled by actively arming the receiver and attempting to start the engine. The engine may start momentarily, but should stall above about 500 rpm.

CAUTION: Repeated sequential starts of the engine to run up the PCM engine start counter and enable the immobilizer system must be avoided. Overheating and damage to the starting system components and wiring can result.

The same immobilizer system enable logic will apply anytime the PCM is replaced with a new unit.

REMOVAL AND INSTALLATION

IMMOBILIZER RECEIVER

NOTE: To access Immobilizer secured access functions, the owner's PIN number will have to be entered into the DRBIII scan tool. The PIN number is printed on the vehicle's window sticker. The PIN number will also have to be entered whenever the immobilizer module is replaced.

(1) Disconnect and isolate the battery negative cable.

(2) Remove the left front door trim panel for RHD vehicles (Fig. 2) or the right front door trim panel for LHD vehicles (Fig. 3). Refer to Group 23—Body in this manual for trim panel removal procedure.

(3) Remove the receiver.

(4) Unplug the immobilizer receiver from the wire harness connector.

(5) Reverse the removal procedures to install.

(6) Refer to the Vehicle Theft Security System menu item on the DRB scan tool for the procedures

REMOVAL AND INSTALLATION (Continued)

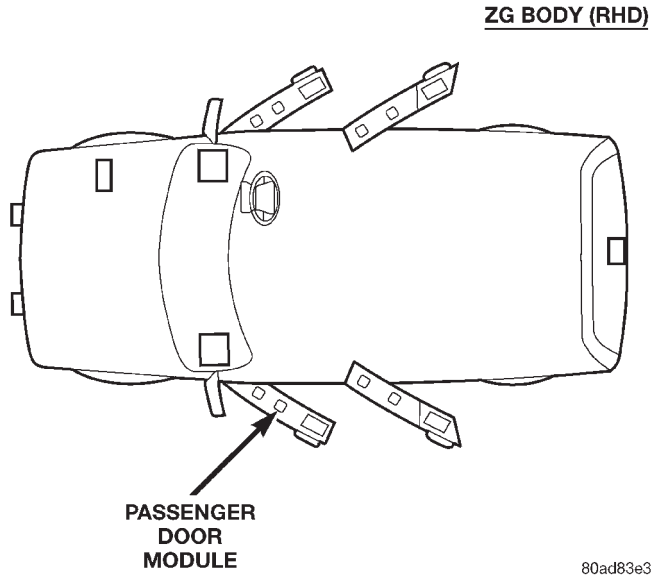


Fig. 2 Immobilizer Receiver Location—RHD Vehicles

80ad83e3

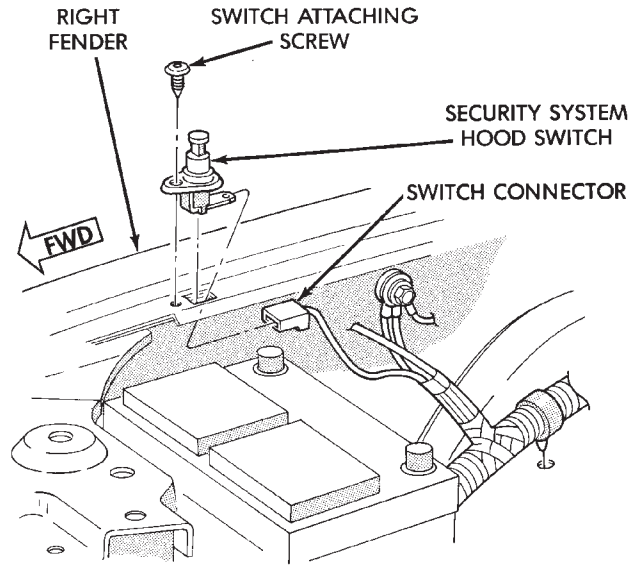


Fig. 4 Hood Switch Remove/Install

J938Q-9

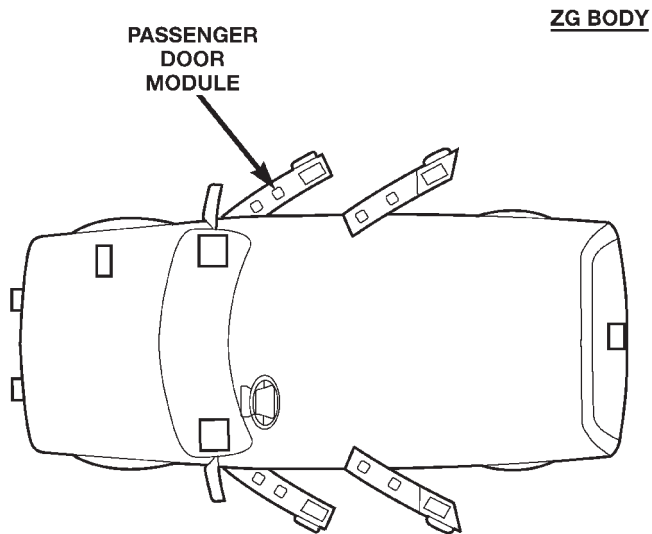


Fig. 3 Immobilizer Receiver Location—LHD Vehicles

80ad83db

DOOR AJAR SWITCH

- (1) Disconnect and isolate the battery negative cable.
- (2) Remove the screw that secures the door ajar switch to the pillar at the rear of the door opening (Fig. 5).

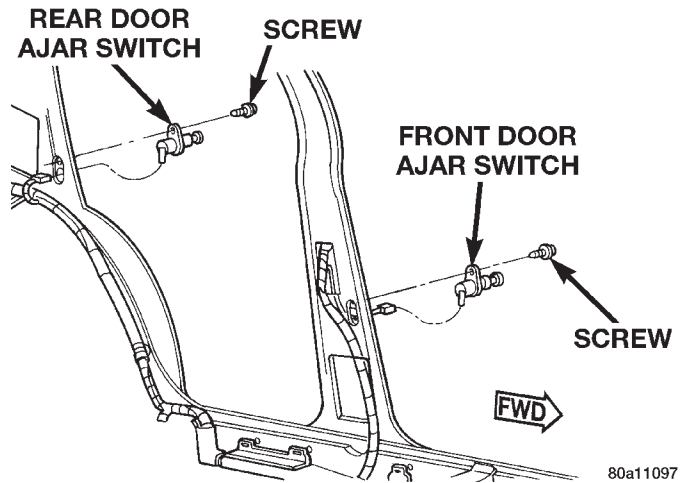


Fig. 5 Door Ajar Switch Remove/Install

80a11097

HOOD SWITCH

- (1) Disconnect and isolate the battery negative cable.
- (2) Remove the screw securing the hood switch to the right inner fender ledge (Fig. 4).
- (3) Unplug the wire connector from the switch.
- (4) Remove the switch from the mounting hole in the inner fender ledge.
- (5) Reverse the removal procedures to install. Tighten the switch mounting screw to 1.5 N·m (15 in. lbs.).

- (3) Pull the switch out from the mounting hole in the door opening far enough to access the wire harness connector.
- (4) Unplug the wire harness connector from the switch.
- (5) Reverse the removal procedures to install. Tighten the switch mounting screw to 1.7 N·m (15 in. lbs.).

REMOVAL AND INSTALLATION (Continued)**DOOR LOCK CYLINDER SWITCH**

(1) Disconnect and isolate the battery negative cable.

(2) Remove the bezel near the inside door latch release handle by inserting a straight-bladed screwdriver in the notched end of the bezel and prying gently upwards.

(3) Remove the screw located beneath the bezel that secures the front door trim panel to the inner door panel (Fig. 6).

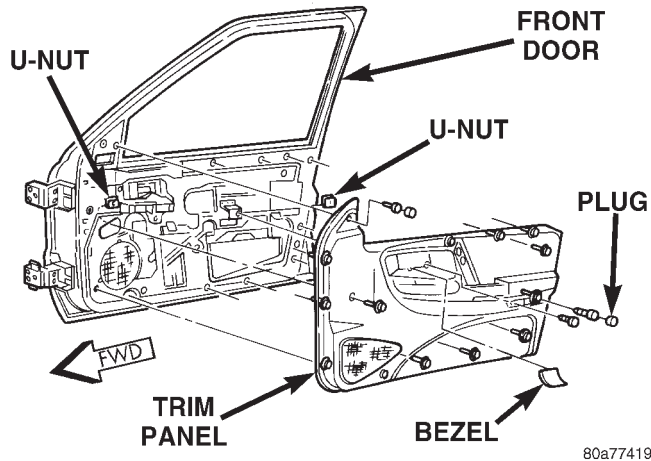


Fig. 6 Front Door Trim Panel Remove/Install

(4) Remove the trim cap and screw near the rear of the front door armrest.

(5) Remove the trim cap and screw at the upper front corner of the front door trim panel.

(6) Remove the screw located above the front door speaker grille on the front door trim panel.

(7) Using a trim stick or another suitable wide flat-bladed tool, gently pry the front door trim panel away from the door around the perimeter to release the trim panel retainers.

NOTE: To aid in the removal of the trim panel, start at the bottom of the panel.

(8) Pull the front door trim panel away from the inner door panel far enough to access and unplug the wire harness connectors from the door module and, if the vehicle is so equipped, from the front door courtesy lamp.

(9) Pull the watershield away from the rear access holes in the front door inner panel.

(10) Remove the U-clip retainer that secures the lock cylinder to the outer door panel (Fig. 7).

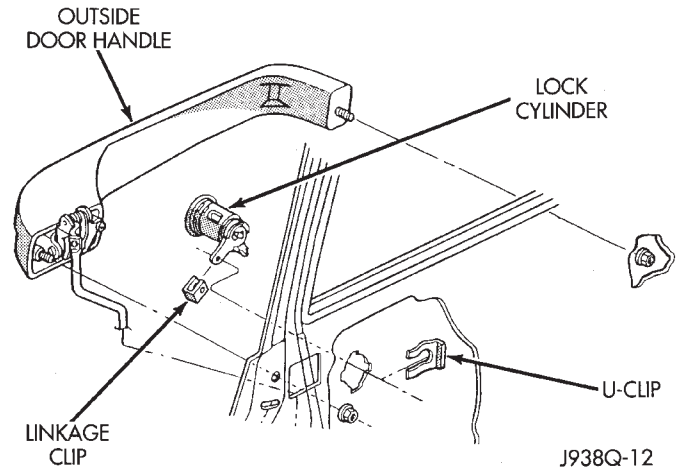


Fig. 7 Door Lock Cylinder Remove/Install

(11) Disconnect the door lock cylinder actuator rod from the door latch by unsnapping the plastic retainer.

(12) Pull the lock cylinder out of its mounting hole from the outside of the door panel far enough to pry the lock cylinder switch off of the back of the lock cylinder (Fig. 8).

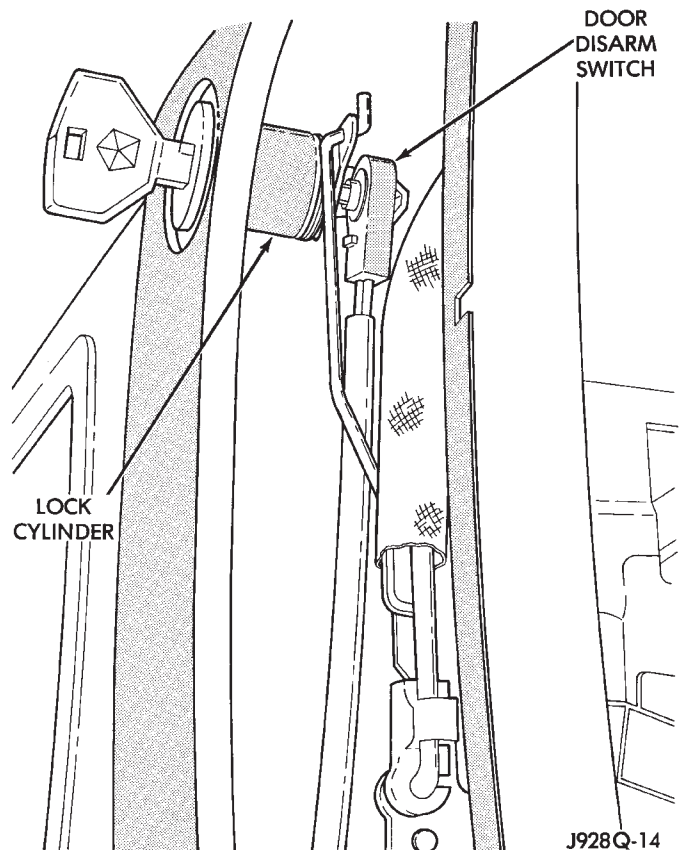


Fig. 8 Door Lock Cylinder Switch Remove/Install - Typical

REMOVAL AND INSTALLATION (Continued)

(13) From the inside of the door unplug the lock cylinder switch wire harness connector and remove the switch from the door.

(14) Reverse the removal procedures to install. Tighten the mounting screws to 2.2 N·m (20 in. lbs.).

LIFTGATE AJAR SWITCH

(1) Disconnect and isolate the battery negative cable.

(2) Open the liftgate.

(3) Remove the screws that secure the liftgate lower trim panel to the liftgate inner panel (Fig. 9).

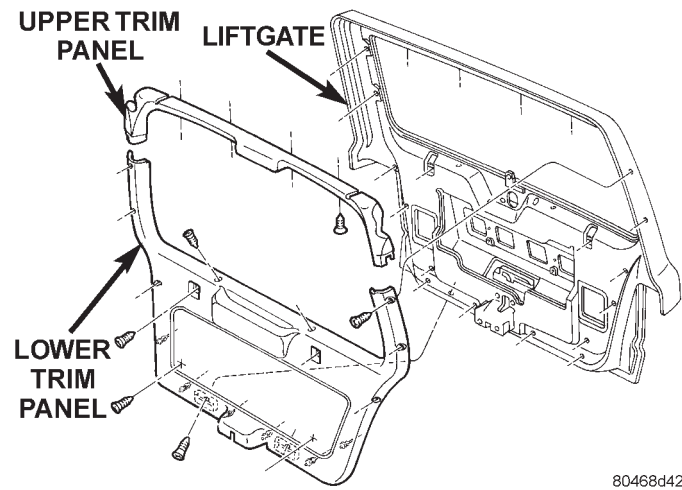


Fig. 9 Liftgate Trim Panel Remove/Install

(4) Using a trim stick or another suitable wide flat-bladed tool, gently pry the perimeter edges of the trim panel away from the liftgate inner panel to release the retainers.

NOTE: To aid in the removal of the trim panel, start at the bottom of the panel.

(5) Remove the liftgate trim panel from the vehicle.

(6) Remove the three screws that secure the liftgate latch to the liftgate (Fig. 10).

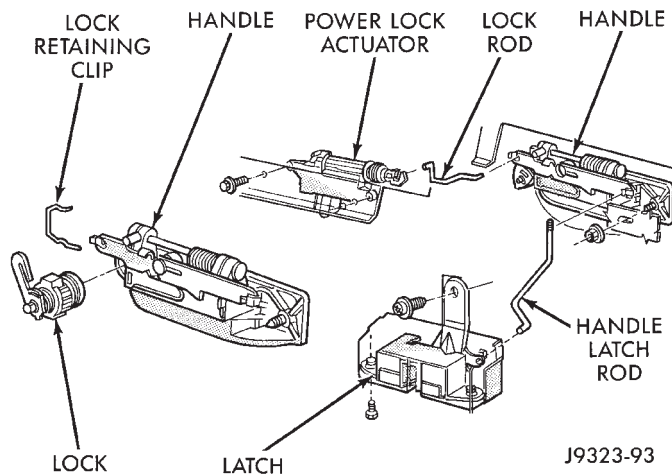


Fig. 10 Liftgate Latch/Lock Components

(7) Disconnect the liftgate handle latch actuator rod from the latch.

(8) Unplug the liftgate ajar switch wire harness connector from the latch.

(9) Remove the latch from the liftgate.

(10) Reverse the removal procedures to install. Tighten the latch mounting screws to 7 N·m (62 in. lbs.).

LIFTGATE LOCK CYLINDER SWITCH

(1) Disconnect and isolate the battery negative cable.

(2) Open the liftgate.

(3) Remove the screws that secure the liftgate lower trim panel to the liftgate inner panel (Fig. 11).

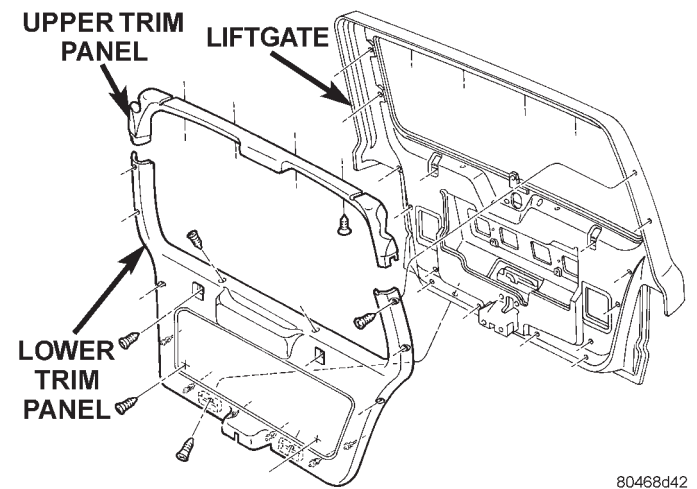


Fig. 11 Liftgate Trim Panel Remove/Install

(4) Using a trim stick or another suitable wide flat-bladed tool, gently pry the perimeter edges of the trim panel away from the liftgate inner panel to release the retainers.

NOTE: To aid in the removal of the trim panel, start at the bottom of the panel.

(5) Remove the lower liftgate trim panel from the vehicle.

(6) Pry the liftgate lock cylinder switch off of the back of the lock cylinder (Fig. 12).

(7) Unplug the lock cylinder switch wire harness connector and remove the switch from inside the liftgate.

(8) Reverse the removal procedures to install. Tighten the mounting screws to 2.2 N·m (20 in. lbs.).

LIFTGLASS AJAR SWITCH

(1) Disconnect and isolate the battery negative cable.

(2) Open the liftgate.

(3) Remove the screws that secure the liftgate lower trim panel to the liftgate inner panel (Fig. 13).

REMOVAL AND INSTALLATION (Continued)

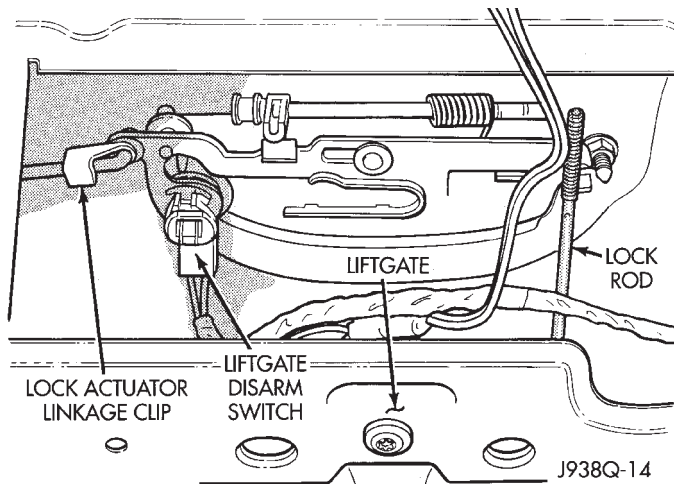


Fig. 12 Liftgate Lock Cylinder Switch Remove/Install

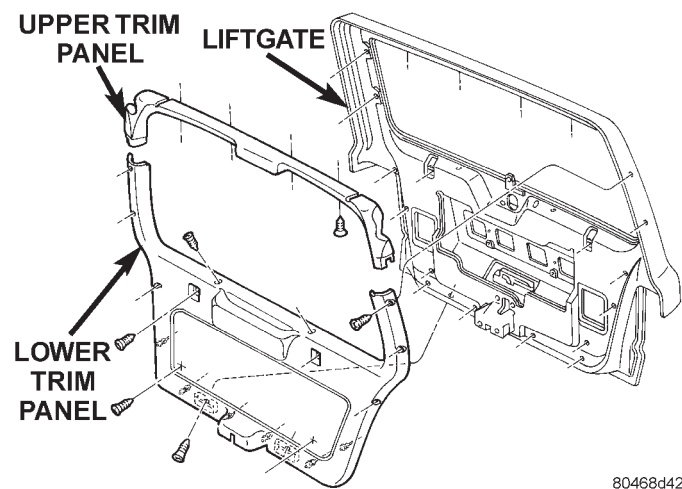


Fig. 13 Liftgate Trim Panel Remove/Install

(4) Using a trim stick or another suitable wide flat-bladed tool, gently pry the perimeter edges of the trim panel away from the liftgate inner panel to release the retainers.

NOTE: To aid in the removal of the trim panel, start at the bottom of the panel.

(5) Remove the lower liftgate trim panel from the vehicle.

(6) Remove the two nuts that secure the liftglass latch to the liftgate inner panel (Fig. 14).

(7) Unplug the wire harness connectors for the liftglass latch solenoid and the liftglass ajar switch.

(8) Remove the liftglass latch from the liftgate.

(9) Reverse the removal procedures to install. Tighten the latch mounting nuts to 11 N·m (100 in. lbs.). Tighten the trim panel mounting screws to 2.2 N·m (20 in. lbs.).

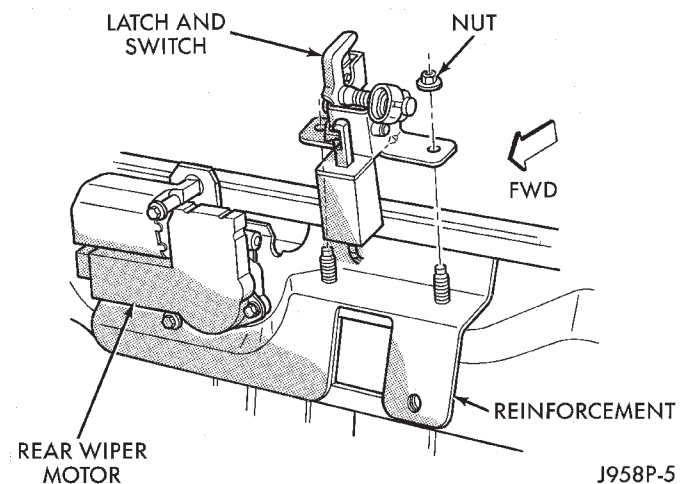


Fig. 14 Liftglass Ajar Switch Remove/Install

AUTO HEADLAMP AND PARK LAMP RELAYS

WARNING: ON VEHICLES EQUIPPED WITH AIRBAGS, REFER TO GROUP 8M - PASSIVE RESTRAINT SYSTEMS BEFORE ATTEMPTING ANY STEERING WHEEL, STEERING COLUMN, OR INSTRUMENT PANEL COMPONENT DIAGNOSIS OR SERVICE. FAILURE TO TAKE THE PROPER PRECAUTIONS COULD RESULT IN ACCIDENTAL AIRBAG DEPLOYMENT AND POSSIBLE PERSONAL INJURY.

(1) Disconnect and isolate the battery negative cable.

(2) Remove the fuse access panel by unsnapping it from the right cowl side trim panel.

(3) Remove the push nut that secures the right cowl side trim panel to the junction block stud (Fig. 15).

(4) Remove the two screws that secure the right cowl side trim panel to the right front door opening trim.

(5) Remove the right cowl side trim panel from the right cowl side inner panel.

(6) Unplug the headlamp or park lamp relay from the junction block.

(7) Install the headlamp or park lamp relay by aligning the relay terminals with the cavities in the junction block and pushing the relay firmly into place.

(8) Connect the battery negative cable.

(9) Test the relay operation.

(10) Reinstall the right cowl side trim and the fuse access panel.

HORN RELAY

(1) Disconnect and isolate the battery negative cable.

REMOVAL AND INSTALLATION (Continued)

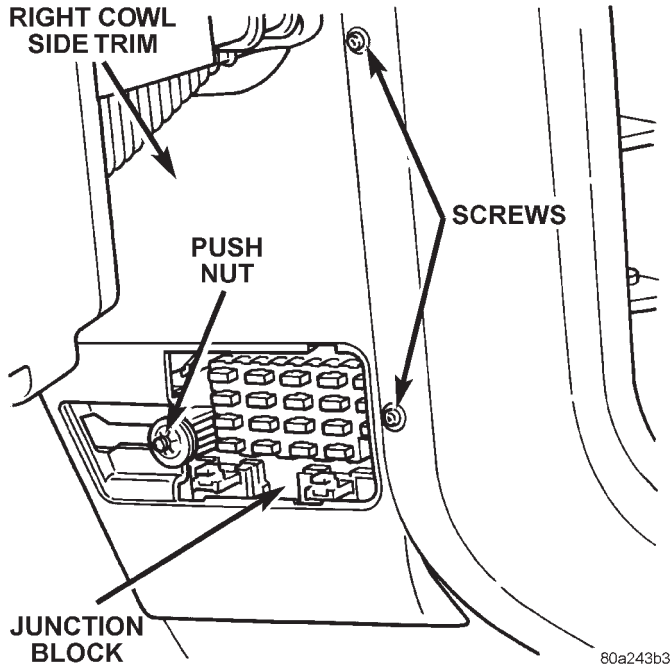


Fig. 15 Right Cowl Side Trim Remove/Install

(2) Remove the cover from the Power Distribution Center (PDC) (Fig. 16).

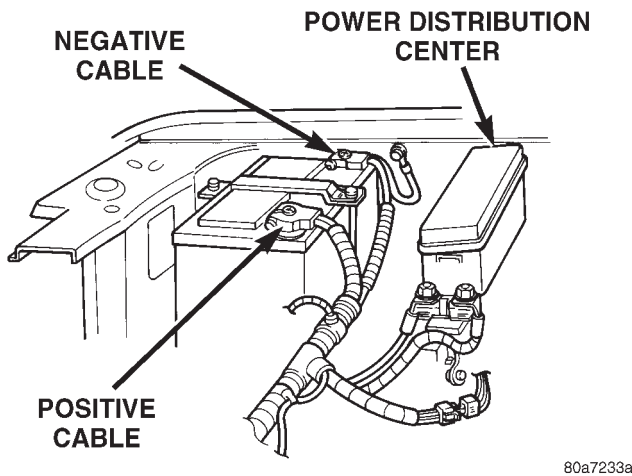


Fig. 16 Power Distribution Center

- (3) Refer to the label on the PDC for horn relay identification and location.
- (4) Unplug the horn relay from the PDC.
- (5) Install the horn relay by aligning the relay terminals with the cavities in the PDC and pushing the relay firmly into place.
- (6) Install the PDC cover.
- (7) Connect the battery negative cable.
- (8) Test the relay operation.

SET LAMP

WARNING: ON VEHICLES EQUIPPED WITH AIR-BAGS, REFER TO GROUP 8M - PASSIVE RESTRAINT SYSTEMS BEFORE ATTEMPTING ANY STEERING WHEEL, STEERING COLUMN, OR INSTRUMENT PANEL COMPONENT DIAGNOSIS OR SERVICE. FAILURE TO TAKE THE PROPER PRECAUTIONS COULD RESULT IN ACCIDENTAL AIR-BAG DEPLOYMENT AND POSSIBLE PERSONAL INJURY.

- (1) Disconnect and isolate the battery negative cable.
- (2) Using a trim stick or another suitable wide flat-bladed tool, gently pry the cowl top trim panel off of the instrument panel top pad (Fig. 17).

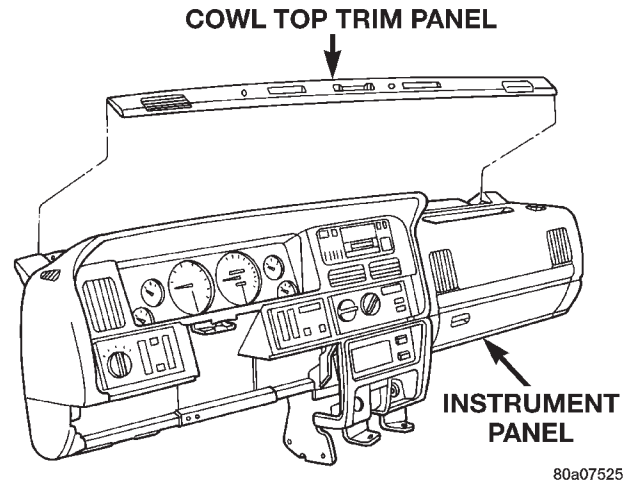


Fig. 17 Cowl Top Trim Remove/Install

- (3) Pull the trim panel up far enough to access and unplug the wire harness connector for the solar sensor, or to remove the solar sensor from the cowl top trim, if the vehicle is so equipped.
- (4) Remove the cowl top trim panel from the instrument panel.
- (5) Remove the auto headlamp light sensor/vehicle theft security system set lamp mounting screw near the driver side defroster duct outlet.
- (6) Pull the set lamp up from the top of the instrument panel far enough to access and unplug the wire harness connector.
- (7) remove the set lamp from the instrument panel.
- (8) Reverse the removal procedures to install. Tighten the mounting screw to 2.2 N·m (20 in. lbs.).

POWER SEAT SYSTEMS

CONTENTS

	page		page
GENERAL INFORMATION			
INTRODUCTION	1	POWER LUMBAR ADJUSTER AND MOTOR ...	5
MEMORY SYSTEM	1	POWER LUMBAR SWITCH	4
DESCRIPTION AND OPERATION			
CIRCUIT BREAKER	3	POWER RECLINER ADJUSTER AND MOTOR ..	4
MEMORY SEAT MODULE	1	POWER SEAT ADJUSTER AND MOTORS	4
POWER LUMBAR ADJUSTER AND MOTOR ...	2	POWER SEAT SWITCH	3
POWER LUMBAR SWITCH	2	POWER SEAT SYSTEM	3
POWER RECLINER ADJUSTER AND MOTOR ..	2	REMOVAL AND INSTALLATION	
POWER SEAT ADJUSTER AND MOTORS	2	MEMORY SEAT MODULE	7
POWER SEAT SWITCH	2	POWER LUMBAR ADJUSTER AND MOTOR ...	7
DIAGNOSIS AND TESTING			
CIRCUIT BREAKER	3	POWER LUMBAR SWITCH	5
		POWER RECLINER ADJUSTER AND MOTOR ..	6
		POWER SEAT ADJUSTER AND MOTORS	5
		POWER SEAT SWITCH	5

GENERAL INFORMATION

INTRODUCTION

Six-way driver and passenger power front seats with power recliners and power lumbar supports are an available factory-installed option for this model. The power seat system receives battery feed through a fuse in the Power Distribution Center (PDC) and a circuit breaker in the junction block at all times.

Following are general descriptions of the major components in the power seat system. Refer to 8W-63 - Power Seat in Group 8W - Wiring Diagrams for complete circuit descriptions and diagrams.

MEMORY SYSTEM

An electronic memory system is an available option on this model. The memory system is able to store and recall the driver side power seat positions (including power lumbar and recliner positions), and both outside power mirror positions for two drivers. For vehicles with a radio connected to the Chrysler Collision Detection (CCD) data bus network, the memory system is also able to store and recall ten radio station presets (including last station tuned) for two drivers. The memory system will automatically return to all of these settings when the corresponding button (Driver 1 or 2) of the memory switch on the driver side front door trim panel is depressed, or when the doors are unlocked using the corresponding (Driver 1 or 2) Remote Keyless Entry (RKE) transmitter.

The Driver Door Module (DDM) receives hard-wired input from the memory set/select switch on the driver side front door trim panel. The DDM also receives messages on the CCD data bus from the RKE receiver in the Passenger Door Module (PDM) for the memory select function. The DDM processes these inputs and sends messages to the PDM, the Memory Seat Module (MSM), and the radio (if CCD data bus capable) on the CCD data bus for memory recall.

The CCD data bus network allows the sharing of sensor information. This helps to reduce wire harness complexity, reduce internal controller hardware, and reduce component sensor current loads. At the same time, this system provides increased reliability, enhanced diagnostics, and allows the addition of many new feature capabilities.

This group covers only the conventional diagnostic procedures for the power seat system components. For diagnosis of the memory system, the use of a DRB scan tool and the proper Diagnostic Procedures manual are recommended. For additional information on the features and functions of the memory system, refer to the owner's manual in the vehicle glove box.

DESCRIPTION AND OPERATION

MEMORY SEAT MODULE

On models equipped with the optional memory system, a Memory Seat Module (MSM), mounted under the inboard side of the driver side front seat cushion, is used to control all of the driver side power seat

DESCRIPTION AND OPERATION (Continued)

memory functions and features. The MSM contains a central processing unit and interfaces with other modules in the vehicle on the Chrysler Collision Detection (CCD) data bus network.

The MSM receives hard-wired inputs from the power seat switch, the power lumbar switch, and the potentiometers on each of the driver side power seat motors. The MSM receives messages on the CCD data bus from the Driver Door Module (DDM) (memory set/select switch status), the Powertrain Control Module (PCM) (vehicle speed status), and the Body Control Module (seat belt switch status). The programming in the MSM allows it to process the information from these inputs and send control outputs to each of the driver side power seat motors. The MSM will prevent the seat memory function from being initiated if the driver side seat belt is buckled, or if the vehicle is moving.

For diagnosis of the MSM or the CCD data bus, a DRB scan tool and the proper Diagnostic Procedures manual are recommended. The MSM cannot be repaired and, if faulty or damaged, it must be replaced.

POWER SEAT SWITCH

The power seat can be adjusted in eight different ways using the power seat switch. The switch is located on the lower outboard side of the seat cushion on the seat cushion side shield. Refer to the owner's manual for more information on the power seat switch functions and the seat adjusting procedures.

The individual switches in the power seat switch module cannot be repaired. If one switch is damaged or faulty, the entire power seat switch module must be replaced.

POWER LUMBAR SWITCH

The power lumbar adjuster on each front seat can be moved in or out electrically by operating the single two-way switch mounted near the front of the outboard seat cushion side shield.

The power lumbar switches cannot be repaired and, if faulty or damaged, they must be replaced.

POWER SEAT ADJUSTER AND MOTORS

There are three reversible motors that operate the power seat adjuster. The motors are connected to worm-drive gearboxes that move the seat adjuster through a combination of screw-type drive units.

The front and rear of a seat are operated by different motors. They can be raised or lowered independently of each other. When the center of the seat switch knob is pushed in the Up or Down direction, both the front and rear motors operate in unison, moving the entire seat up or down. The forward-rear-

ward motor is operated by pushing the seat switch knob in the Forward or Rearward direction.

When a power seat switch is actuated, a battery feed and a ground path are applied through the switch contacts to the motor(s). The motor(s) and drive unit(s) operate to move the seat in the selected direction until the switch is released, or until the travel limit of the power seat adjuster is reached. When the switch is moved in the opposite direction, the battery feed and ground path to the motor(s) are reversed through the switch contacts. This causes the motor to run in the opposite direction.

Each motor contains a self-resetting circuit breaker to protect it from overload. Consecutive or frequent resetting of the circuit breakers must not be allowed to continue, or the motors may be damaged. Make the necessary repairs. The motors used on models with the optional memory system also have a position potentiometer included in the motor assembly.

The power seat adjuster and motors cannot be repaired, and are serviced only as a complete unit. If any component in this unit is faulty or damaged, the entire power seat adjuster and motors assembly must be replaced.

POWER RECLINER ADJUSTER AND MOTOR

The power recliner adjuster uses a reversible motor to operate the seat back recliner adjuster. The motor is connected to a gearbox that moves the recliner adjuster through a screw-type drive unit.

When the power recliner switch is actuated, a battery feed and a ground path are applied through the switch contacts to the motor. The motor operates to move the seat back in the selected direction until the switch is released, or until the travel limit of the power recliner adjuster is reached. When the switch is moved in the opposite direction, the battery feed and ground path to the motor are reversed through the switch contacts. This causes the motor to run in the opposite direction.

The motor contains a self-resetting circuit breaker to protect it from overload. Consecutive or frequent resetting of the circuit breaker must not be allowed to continue, or the motor may be damaged. Make the necessary repairs. The motor used on models with the optional memory system also has a position potentiometer included in the motor assembly.

The power recliner adjuster and motor cannot be repaired, and is serviced only as a complete unit. If any component in this unit is faulty or damaged, the entire power recliner adjuster and motor assembly must be replaced.

POWER LUMBAR ADJUSTER AND MOTOR

There is a reversible motor that operates the power lumbar adjuster. The motor is connected to a worm-

DESCRIPTION AND OPERATION (Continued)

drive gearbox that moves the lumbar adjuster mechanism through a cable and lever-type actuator unit.

When the power lumbar switch is actuated, a battery feed and a ground path are applied through the switch contacts to the motor. The motor operates to move the lumbar adjuster mechanism in the selected direction until the switch is released, or until the travel limit of the lumbar adjuster is reached. When the switch is moved in the opposite direction, the battery feed and ground path to the motor are reversed through the switch contacts. This causes the motor to run in the opposite direction.

The motor contains a self-resetting circuit breaker to protect it from overload. Consecutive or frequent resetting of the circuit breaker must not be allowed to continue, or the motor may be damaged. Make the necessary repairs. The motor used on models with the optional memory system also has a position potentiometer included in the motor assembly.

The power lumbar adjuster and motor cannot be repaired, and are serviced only as a complete unit with the seat back frame. If any component in this unit is damaged or is faulty, the entire power lumbar seat back frame assembly must be replaced.

CIRCUIT BREAKER

An automatic resetting circuit breaker in the junction block is used to protect the power seat system circuit. The circuit breaker can protect the system from a short circuit, or from an overload condition caused by an obstructed or stuck seat adjuster.

The circuit breaker cannot be repaired and, if faulty or damaged, it must be replaced.

DIAGNOSIS AND TESTING**POWER SEAT SYSTEM**

Before any testing of the power seat system is attempted, the battery should be fully-charged and all wire harness connections and pins cleaned and tightened to ensure proper continuity and grounds. For circuit descriptions and diagrams, refer to 8W-63 - Power Seat in Group 8W - Wiring Diagrams.

With the dome lamp on, apply the power seat switch in the direction of the failure. If the dome lamp dims, the seat may be jamming. Check under and behind the seat for binding or obstructions. If the dome lamp does not dim, proceed with testing of the individual components and circuits.

CIRCUIT BREAKER

For circuit descriptions and diagrams, refer to 8W-63 - Power Seat in Group 8W - Wiring Diagrams.

(1) Locate the correct circuit breaker in the junction block. Pull out the circuit breaker slightly, but

be certain that the circuit breaker terminals still contact the terminals in the junction block cavities.

(2) Connect the negative lead of a 12-volt DC voltmeter to a good ground.

(3) With the voltmeter positive lead, check both terminals of the circuit breaker for battery voltage.

If only one terminal has battery voltage, the circuit breaker is faulty and must be replaced. If neither terminal has battery voltage, repair the open circuit from the Power Distribution Center (PDC) as required.

POWER SEAT SWITCH

For circuit descriptions and diagrams, refer to 8W-63 - Power Seat in Group 8W - Wiring Diagrams.

(1) Disconnect and isolate the battery negative cable. Remove the power seat switch from the power seat.

(2) Use an ohmmeter to test the continuity of the power seat switches in each position. See the Power Seat Switch Continuity chart (Fig. 1). If OK, see the diagnosis for the Power Seat Adjuster and Motors or Power Recliner Adjuster and Motor, as required. If not OK, replace the faulty power seat switch module.

POWER LUMBAR SWITCH

For circuit descriptions and diagrams, refer to 8W-63 - Power Seat in Group 8W - Wiring Diagrams.

(1) Disconnect and isolate the battery negative cable. Remove the power lumbar switch from the power seat.

(2) Use an ohmmeter to test the continuity of the power lumbar switch in each switch position. See the Power Lumbar Switch Continuity chart (Fig. 2). If OK, see the diagnosis for the Power Lumbar Adjuster and Motor. If not OK, replace the faulty power lumbar switch.

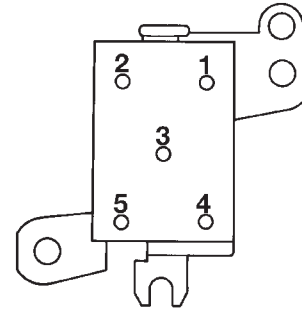
POWER SEAT ADJUSTER AND MOTORS

The tests below apply to a power seat system without the memory system option. For testing of the power seats with the memory system, refer to the proper Diagnostic Procedures manual. For circuit descriptions and diagrams, refer to 8W-63 - Power Seat in Group 8W - Wiring Diagrams.

Operate the power seat switch to move all three seat motors in each direction. The seat should move in each of the selected directions. If the power seat adjuster fails to operate in only one direction, move the adjuster a short distance in the opposite direction and test again to be certain that the adjuster is not at its travel limit. If the power seat adjuster still fails to operate in only one direction, see the diagnosis for the Power Seat Switch in this group. If the power seat adjuster fails to operate in more than one direction, proceed as follows:

DIAGNOSIS AND TESTING (Continued)

SWITCH POSITION	CONTINUITY BETWEEN PINS	
	LEFT SEAT	RIGHT SEAT
OFF	PIN 1 to 2	PIN 1 to 2
	PIN 1 to 3	PIN 1 to 3
	PIN 1 to 4	PIN 1 to 4
	PIN 1 to 6	PIN 1 to 6
	PIN 1 to 7	PIN 1 to 7
	PIN 1 to 8	PIN 1 to 8
	PIN 1 to 9	PIN 1 to 9
	PIN 1 to 10	PIN 1 to 10
FRONT RISER UP	PIN 1 to 10	PIN 1 to 7
	PIN 5 to 7	PIN 5 to 10
FRONT RISER DOWN	PIN 1 to 7	PIN 1 to 10
	PIN 5 to 10	PIN 5 to 7
CENTER SWITCH FORWARD	PIN 1 to 3	PIN 1 to 3
	PIN 5 to 6	PIN 5 to 6
CENTER SWITCH REARWARD	PIN 1 to 6	PIN 1 to 6
	PIN 3 to 5	PIN 3 to 5
REAR RISER UP	PIN 1 to 9	PIN 1 to 8
	PIN 5 to 8	PIN 5 to 9
REAR RISER DOWN	PIN 1 to 8	PIN 1 to 9
	PIN 5 to 9	PIN 5 to 8
RECLINER UP	PIN 1 to 4	PIN 1 to 4
	PIN 2 to 5	PIN 2 to 5
RECLINER DOWN	PIN 1 to 2	PIN 1 to 2
	PIN 4 to 5	PIN 4 to 5



SWITCH POSITION	CONTINUITY BETWEEN
NEUTRAL	1 AND 4
NEUTRAL	2 AND 5
FORWARD	1 AND 4
FORWARD	3 AND 5
REARWARD	1 AND 3
REARWARD	2 AND 5

80a1374b

Fig. 2 Power Lumbar Switch Continuity

power seat switch and the motor for shorts or opens. If the circuits check OK, replace the faulty power seat adjuster and motors assembly. If the circuits are not OK, repair the wire harness as required.

POWER RECLINER ADJUSTER AND MOTOR

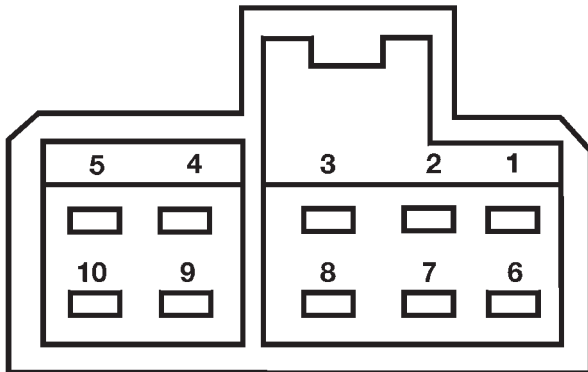
The tests below apply to a power seat system without the memory system option. For testing of the power seats with the memory system, refer to the proper Diagnostic Procedures manual. For circuit descriptions and diagrams, refer to 8W-63 - Power Seat in Group 8W - Wiring Diagrams.

Operate the power seat switch to move the power recliner adjuster in each direction. The recliner adjuster should move in both directions. If the power recliner adjuster fails to operate in only one direction, move the adjuster a short distance in the opposite direction and test again to be certain that the adjuster is not at its travel limit. If the power recliner adjuster still fails to operate in only one direction, see the diagnosis for the Power Seat Switch in this group. If the power recliner adjuster fails to operate in either direction, proceed as follows:

(1) Test the circuit breaker in the junction block as described in this group. If OK, go to Step 2. If not OK, replace the faulty circuit breaker.

(2) Remove the power seat switch from the seat. Check for battery voltage at the fused B(+) circuit cavity of the power seat switch wire harness connector. If OK, go to Step 3. If not OK, repair the open circuit to the junction block as required.

(3) Check for continuity between the ground circuit cavity of the power seat switch wire harness con-



80a2b429

Fig. 1 Power Seat Switch Continuity

(1) Test the circuit breaker in the junction block as described in this group. If OK, go to Step 2. If not OK, replace the faulty circuit breaker.

(2) Remove the power seat switch from the seat. Check for battery voltage at the fused B(+) circuit cavity of the power seat switch wire harness connector. If OK, go to Step 3. If not OK, repair the open circuit to the junction block as required.

(3) Check for continuity between the ground circuit cavity of the power seat switch wire harness connector and a good ground. There should be continuity. If OK, go to Step 4. If not OK, repair the open circuit to ground as required.

(4) Test the power seat switch as described in this group. If the switch tests OK, check the wire harness to the inoperative power seat motor(s) between the

DIAGNOSIS AND TESTING (Continued)

necter and a good ground. There should be continuity. If OK, go to Step 4. If not OK, repair the open circuit to ground as required.

(4) Test the power seat switch as described in this group. If the switch tests OK, check the wire harness for the power recliner adjuster motor between the power seat switch and the motor for shorts or opens. If the circuits check OK, replace the faulty power recliner adjuster and motor assembly. If the circuits are not OK, repair the wire harness as required.

POWER LUMBAR ADJUSTER AND MOTOR

The tests below apply to a power seat system without the memory system option. For testing of the power seats with the memory system, refer to the proper Diagnostic Procedures manual. For circuit descriptions and diagrams, refer to 8W-63 - Power Seat in Group 8W - Wiring Diagrams.

Operate the power lumbar switch to move the power lumbar adjuster in each direction. The lumbar adjuster should move in both directions. If the power lumbar adjuster fails to operate in only one direction, move the adjuster a short distance in the opposite direction and test again to be certain that the adjuster is not at its travel limit. If the power lumbar adjuster still fails to operate in only one direction, see the diagnosis for the Power Lumbar Switch in this group. If the power lumbar adjuster fails to operate in either direction, proceed as follows:

(1) Test the circuit breaker in the junction block as described in this group. If OK, go to Step 2. If not OK, replace the faulty circuit breaker.

(2) Remove the power lumbar switch from the seat. Check for battery voltage at the fused B(+) circuit cavity of the power lumbar switch wire harness connector. If OK, go to Step 3. If not OK, repair the open circuit to the junction block as required.

(3) Check for continuity between the ground circuit cavity of the power lumbar switch wire harness connector and a good ground. There should be continuity. If OK, go to Step 4. If not OK, repair the open circuit to ground as required.

(4) Test the power lumbar switch as described in this group. If the switch tests OK, check the wire harness for the power lumbar adjuster motor between the power lumbar switch and the motor for shorts or opens. If the circuits check OK, replace the faulty power lumbar adjuster and motor, which are serviced with the seat back frame assembly. If the circuits are not OK, repair the wire harness as required.

REMOVAL AND INSTALLATION

POWER SEAT SWITCH

(1) Disconnect and isolate the battery negative cable.

(2) Using a trim stick or another suitable wide flat-bladed tool, gently pry the power seat and power recliner switch knobs off of the switch stems.

(3) Remove the three screws that secure the seat cushion side shield to the outboard seat cushion frame.

(4) Pull the seat cushion side shield away from the seat cushion frame far enough to access the power seat switch and power lumbar switch wire harness connectors.

(5) Unplug the wire harness connectors from the power seat and power lumbar switches.

(6) Remove the seat cushion side shield from the vehicle.

(7) Remove the two screws that secure the power seat switch to the inside of the seat cushion side shield (Fig. 3).

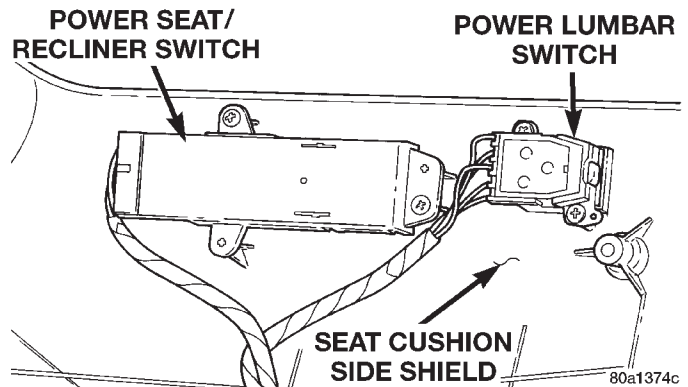


Fig. 3 Power Seat Switches Remove/Install

(8) Remove the power seat switch from the seat cushion side shield.

(9) Reverse the removal procedures to install. Tighten the mounting screws to 2.2 N·m (20 in. lbs.).

POWER LUMBAR SWITCH

(1) Disconnect and isolate the battery negative cable.

(2) Remove the three screws that secure the seat cushion side shield to the outboard seat cushion frame.

(3) Pull the seat side shield away from the seat cushion frame far enough to access the power seat switch and power lumbar switch wire harness connectors.

(4) Unplug the power seat switch and power lumbar switch wire harness connectors from the switches.

(5) Remove the seat side shield from the vehicle.

REMOVAL AND INSTALLATION (Continued)

(6) Remove the two screws that secure the power lumbar switch to the inside of the seat side shield.

(7) Remove the power lumbar switch from the seat side shield.

(8) Reverse the removal procedures to install. Tighten the mounting screws to 2.2 N-m (20 in. lbs.).

POWER SEAT ADJUSTER AND MOTORS

(1) Move the seat to its fully forward position, if possible.

(2) Remove the single screw that secures each of the two rear seat track covers to the rear of the seat tracks and remove the covers.

(3) Remove the single screw that secures the rear of each of the two seat tracks to the floor panel.

(4) Move the seat to its fully rearward position, if possible.

(5) Disconnect and isolate the battery negative cable.

(6) Remove the single screw that secures the front of each of the two seat tracks to the floor panel (Fig. 4).



Fig. 4 Power Seat Remove/Install - Typical

(7) Tilt the seat rearward and unplug the power seat wire harness connector located on the floor below the seat cushion.

(8) Remove the seat and adjuster assembly from the vehicle.

(9) Remove the three screws that secure the outboard seat cushion side shield to the seat cushion frame and pull the shield away from the seat cushion.

(10) For the driver side front seat only, if the vehicle is equipped with the optional memory seat module, the memory seat module must be removed from

the inboard side of the driver side front seat. See Memory Seat Module in this group for the procedures.

(11) Remove the four nuts that secure the upper seat adjuster mounting rails to the seat cushion frame.

(12) Unplug the wire harness connectors from the power adjuster motors as required, depending upon how the vehicle is equipped, to separate the power seat adjuster and motors assembly from the seat cushion frame.

(13) Reverse the removal procedures to install. Tighten the seat mounting hardware as follows:

- Seat cushion frame to adjuster nuts - 20 N-m (15 ft. lbs.)
- Seat adjuster to floor pan screws - 29 N-m (20 ft. lbs.)
- Seat cushion side shield screws - 2.2 N-m (20 in. lbs.).

POWER RECLINER ADJUSTER AND MOTOR

(1) Move the seat to its fully forward and fully raised positions, if possible.

(2) Remove the three screws that secure the outboard seat cushion side shield to the seat cushion frame and pull the shield away from the seat cushion far enough to access the power recliner adjuster lower bracket.

(3) If possible, adjust the seat back with the power recliner switch far enough to access both of the two screws in the power recliner adjuster lower bracket.

(4) Disconnect and isolate the battery negative cable.

(5) Remove the two screws that secure the power recliner adjuster lower bracket to the seat cushion frame (Fig. 5).

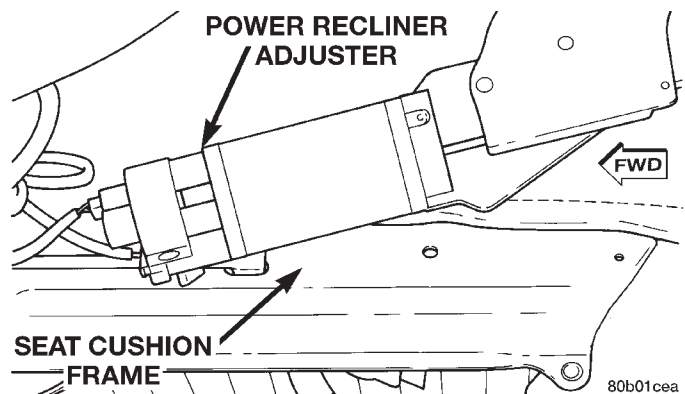


Fig. 5 Power Recliner Adjuster Lower Bracket Remove/Install

(6) Remove the inboard seat back pivot screw.

(7) Unplug any wire harness connectors between the seat back and the seat cushion, the number of which will vary with the vehicle equipment.

REMOVAL AND INSTALLATION (Continued)

(8) Remove the seat back from the seat cushion and place it on a suitable work surface.

(9) Carefully pull up the side of the seat back cover far enough to access the two screws that secure the power recliner adjuster upper bracket to the seat back frame (Fig. 6). Refer to Group 23 - Body for the seat back cover removal procedures.

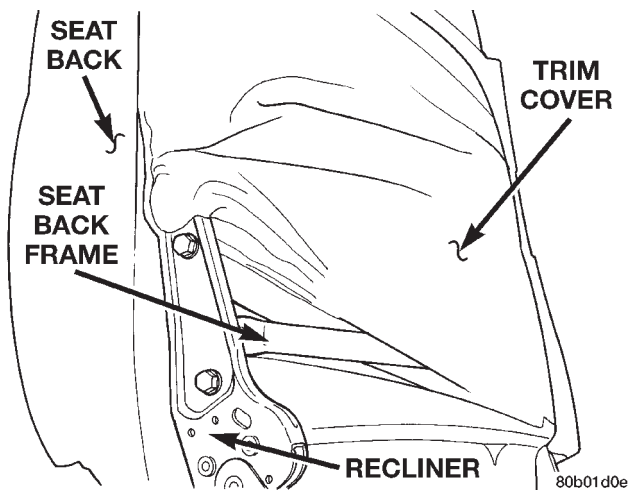


Fig. 6 Power Recliner Adjuster Upper Bracket Remove/Install

(10) Remove the power recliner adjuster and motor unit from the seat back frame.

(11) Reverse the removal procedures to install. Tighten the hardware as follows:

- Inboard pivot screw - 40 N·m (29 ft. lbs.)
- Recliner adjuster bracket screws - 28 N·m (20 ft. lbs.)
- Seat cushion side shield screws - 2.2 N·m (20 in. lbs.).

POWER LUMBAR ADJUSTER AND MOTOR

(1) Remove the power recliner adjuster and motor from the seat back frame. See Power Recliner Adjuster and Motor in this group for the procedures.

(2) Remove all of the seat back trim from the seat back. Refer to Group 23 - Body for the procedures.

(3) Replace the seat back frame assembly, which includes the lumbar adjuster and motor (Fig. 7).

(4) Reverse the removal procedures to install.

MEMORY SEAT MODULE

(1) Move the driver side front seat to its fully forward and fully raised positions, if possible.

(2) Remove the single screw that secures each of the two rear seat track covers to the rear of the seat tracks and remove the covers.

(3) Remove the single screw that secures the rear of each of the two seat tracks to the floor panel.

(4) Move the driver side seat to its fully rearward position, if possible.

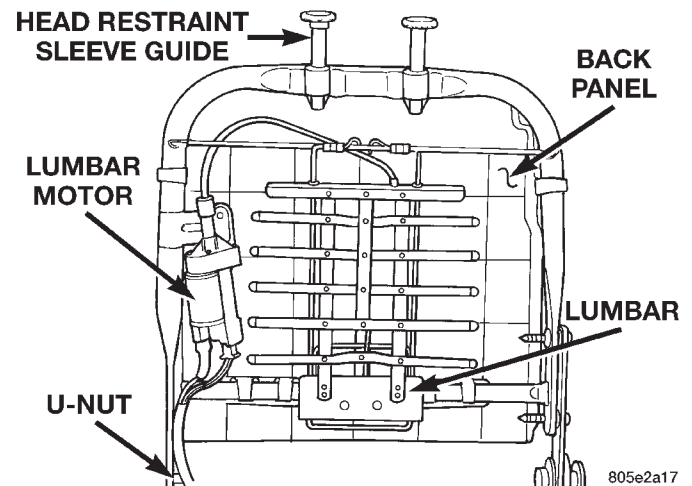


Fig. 7 Power Lumbar Adjuster and Motor

(5) Disconnect and isolate the battery negative cable.

(6) Remove the single screw that secures the front of each of the two seat tracks to the floor panel.

(7) Carefully tilt the top of the seat back towards the outboard side of the vehicle.

(8) Release the two retainers that secure the memory seat module wire harness to the inboard seat adjuster top rail (Fig. 8).

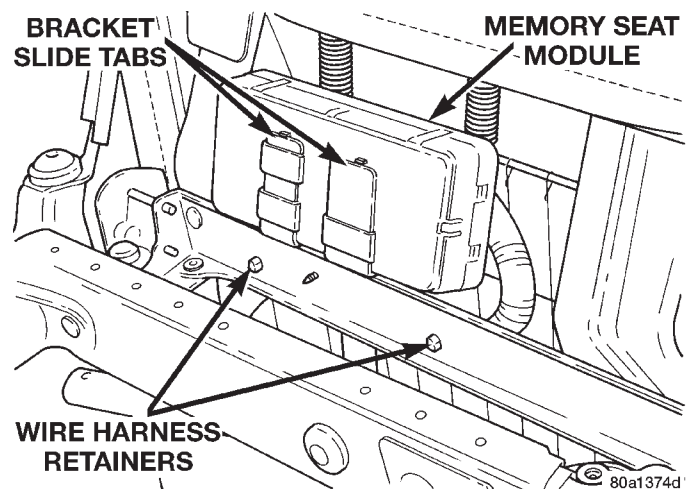


Fig. 8 Memory Seat Module Remove/Install

(9) There are two snap clips that are molded into the side of the memory seat module closest to the seat adjuster, which help to secure the module to the riser portion of the stepped mounting bracket. Using a trim stick or another suitable wide flat-bladed tool, reach between the module and the seat adjuster to gently pry each of the two snap clips while pulling the module away from the mounting bracket.

(10) Slide the memory seat module off of the two mounting bracket slide tabs far enough to access and unplug the wire harness connectors.

REMOVAL AND INSTALLATION (Continued)

(11) Remove the memory seat module from under the seat cushion.

(12) Reverse the removal procedures to install. Tighten the seat mounting hardware as follows:

- Seat cushion frame to adjuster nuts - 20 N·m (15 ft. lbs.)
- Seat adjuster to floor panel screws - 29 N·m (20 ft. lbs.).

NOTE: Following installation, it will be necessary to initialize the memory seat module. This is done by moving each of the power seat adjuster motors (including the power recliner and power lumbar motors) through its full range of motion using the power seat switches. In order to function properly, the memory seat module must “learn” the motor sensor values in each of the adjuster hard stop positions.

POWER WINDOW SYSTEMS

CONTENTS

	page		page
GENERAL INFORMATION			
INTRODUCTION	1	DOOR MODULE	3
POWER WINDOW SYSTEM	1	POWER WINDOW MOTOR	5
DESCRIPTION AND OPERATION			
BODY CONTROL MODULE	2	POWER WINDOW SWITCH	4
CIRCUIT BREAKER	3	POWER WINDOW SYSTEM	3
DOOR MODULE	2	REMOVAL AND INSTALLATION	
POWER WINDOW MOTOR	2	DOOR MODULE	5
POWER WINDOW SWITCH	1	POWER WINDOW MOTOR	7
DIAGNOSIS AND TESTING			
CIRCUIT BREAKER	3	POWER WINDOW SWITCH	6

GENERAL INFORMATION

INTRODUCTION

Power windows are standard factory-installed equipment on this model. This group covers diagnosis and service of only the electrical components in the power window system. For service of mechanical components, such as the regulator, lift plate, window tracks, or glass refer to Group 23 - Body.

Following are general descriptions of the major components in the power window system. Refer to 8W-60 - Power Windows in Group 8W - Wiring Diagrams for complete circuit descriptions and diagrams. Refer to the owner's manual for more information on the features and use of this system.

POWER WINDOW SYSTEM

The power window system allows each of the door windows to be opened or closed by operating a switch on the trim panel for that door. The master switches on the driver side front door trim panel can be operated to open or close any of the door windows. In addition, a lockout switch on the driver side front door trim panel allows the driver to disable all of the passenger door window switches.

The power window system includes the Driver Door Module (DDM) and Passenger Door Module (PDM), which are mounted in their respective front door, the switches mounted on the rear doors, and the power window motors mounted to the window regulator in each door. In addition, several features and functions of the power window system are made possible because of the communication of the DDM and PDM on the Chrysler Collision Detection (CCD) data bus network.

The power window system operates with battery power supplied through a circuit breaker in the junction block, only when the ignition switch is in the On position. However, a unique feature of this system will allow the power windows to be operated for up to thirty seconds after the ignition switch is turned to the Off position, or until a front door is opened, whichever occurs first.

An auto-down feature allows the driver side front door window to be lowered all the way, even if the window switch is released. The driver side front door window switch must be depressed in the down direction to a second detent to begin an auto-down event. Depressing the switch again in any direction will stop the window movement and cancel the auto-down event.

DESCRIPTION AND OPERATION

POWER WINDOW SWITCH

The power windows are controlled by a two-way momentary switch mounted on the trim panel of each passenger door, and four two-way momentary switches on the driver side front door trim panel. The driver side front door trim panel also has a two-position power window lockout switch.

Each power window switch, except the lockout switch, is illuminated by a Light-Emitting Diode (LED) when the ignition switch is turned to the On position. However, when the lockout switch is placed in the Lock position, the LED for the locked-out front and rear passenger door power window switches is turned off.

The front door power window switches and the power window lockout switch are integral to the Driver Door Module (DDM) or Passenger Door Mod-

DESCRIPTION AND OPERATION (Continued)

ule (PDM), respectively. These power window switches provide an up or down (or lock and unlock signal in the case of the lockout switch) to the door module circuitry.

The DDM circuitry controls the output to the driver side front and rear door power window motors, and supplies electrical current as required for the stand-alone operation of the driver side rear door power window switch. The PDM circuitry controls the output to the passenger side front and rear door power window motors, and supplies electrical current as required for the stand-alone operation of the passenger side rear door power window switch. When a DDM-integrated power window switch for a passenger side window is actuated, the DDM circuitry sends a message to the PDM on the Chrysler Collision Detection (CCD) data bus to activate the output to that power window motor(s).

The front door power window switches and their lamps cannot be repaired so, if faulty or damaged, the entire door module must be replaced. The rear door power window switches and their lamps cannot be repaired but, if faulty or damaged, only the affected rear door switch must be replaced.

DOOR MODULE

A Driver Door Module (DDM) and a Passenger Door Module (PDM) are used on this model to control and integrate many of the electronic features and functions on the vehicle. Each door module houses both the front power lock and power window switches. The DDM also houses individual switches for each passenger door power window, a power window lockout switch and the power mirror switch.

The DDM and PDM communicate with each other, and with other vehicle modules on the Chrysler Collision Detection (CCD) data bus network. The CCD data bus network allows the sharing of sensor information. This helps to reduce wire harness complexity, internal controller hardware, and component sensor current loads. At the same time, this system provides increased reliability, enhanced diagnostics, and allows the addition of many new feature capabilities.

The DDM circuitry controls the output to the driver side front and rear door power windows. The PDM circuitry controls the output to the passenger side front and rear door power windows. The DDM can control the PDM output by sending control messages to the PDM over the CCD data bus.

Some of the features and functions of the power window system made possible because of the communication of the door modules on the CCD data bus network include:

- Power window operation after ignition off feature.
- Power window lockout function.

- Power window switch LED illumination control function.

For diagnosis of the DDM, PDM, or the CCD data bus network, a DRB scan tool and the proper Diagnostic Procedures manual are recommended. The DDM and the PDM cannot be repaired and, if damaged or faulty, they must be replaced.

BODY CONTROL MODULE

A Body Control Module (BCM) is used on this model to control and integrate many of the electronic functions and features included on the vehicle. The BCM contains a central processing unit and interfaces with other modules in the vehicle on the Chrysler Collision Detection (CCD) data bus network.

The CCD data bus network allows the sharing of sensor information. This helps to reduce wire harness complexity, reduce internal controller hardware, and reduce component sensor current loads. At the same time, this system provides increased reliability, enhanced diagnostics, and allows the addition of many new feature capabilities.

One of the functions and features that the BCM supports and controls, is the power window system. The BCM receives inputs from the ignition switch and the door ajar switches. The programming in the BCM allows it to process the information from these inputs and send ignition switch and door ajar status messages to the Driver Door Module (DDM) and the Passenger Door Module (PDM) on the CCD data bus. The DDM and PDM use this information to control the lighting of the power window switch lamps, and to control the operation of the power window after ignition-off feature.

The BCM is mounted under the driver side outboard end of the instrument panel, behind the instrument panel support armature and below the outboard switch pod. Refer to Group 8E - Instrument Panel Systems for the removal and installation procedures. For diagnosis of the BCM or the CCD data bus, the use of a DRB scan tool and the proper Diagnostic Procedures manual are recommended. The BCM can only be serviced by an authorized electronic repair station. Refer to the latest Warranty Policies and Procedures manual for a current listing of authorized electronic repair stations.

POWER WINDOW MOTOR

A permanent magnet reversible motor moves the window regulator through an integral gearbox mechanism. A positive and negative battery connection to the two motor terminals will cause the motor to rotate in one direction. Reversing the current through these same two connections will cause the motor to rotate in the opposite direction.

DESCRIPTION AND OPERATION (Continued)

In addition, each power window motor is equipped with an integral self-resetting circuit breaker to protect the motor from overloads. The power window motor and gearbox assembly cannot be repaired and, if faulty or damaged, the entire motor assembly must be replaced.

CIRCUIT BREAKER

An automatic resetting circuit breaker in the junction block is used to protect the power window system circuit. The circuit breaker can protect the system from a short circuit, or from an overload condition caused by an obstructed or stuck window glass or regulator.

The circuit breaker cannot be repaired and, if faulty, it must be replaced.

DIAGNOSIS AND TESTING**POWER WINDOW SYSTEM**

NOTE: The following tests may not prove conclusive in the diagnosis of this component. The most reliable, efficient, and accurate means to diagnose this system involves the use of a DRB scan tool and the proper Diagnostic Procedures manual.

Remember, the Driver Door Module (DDM) circuitry controls the output to the driver side front and rear power window motors. The Passenger Door Module (PDM) circuitry controls the output to the passenger side front and rear power window motors. For circuit descriptions and diagrams, refer to 8W-60 - Power Windows in Group 8W - Wiring Diagrams.

ALL WINDOWS INOPERATIVE

(1) Check the circuit breaker in the junction block, as described in this group. If OK, go to Step 2. If not OK, replace the faulty circuit breaker.

(2) Disconnect and isolate the battery negative cable. Remove the left and right front door trim panels. Check the 12-way door module wire harness connectors to see that they are fully seated in the door module receptacles. If OK, go to Step 3. If not OK, install the wire harness connectors properly.

(3) Unplug the 12-way door module wire harness connectors. Check for continuity between the ground circuit cavity of each door module wire harness connector and a good ground. If OK, go to Step 4. If not OK, repair the open circuit as required.

(4) Connect the battery negative cable. Check for battery voltage at the fused B(+) circuit cavity of each 12-way door module wire harness connector. If OK, use a DRB scan tool and the proper Diagnostic Procedures manual to diagnose the door modules and

the CCD data bus. If not OK, repair the open circuit to the junction block as required.

ONE WINDOW INOPERATIVE

The window glass must be free to slide up and down for the power window motor to function properly. If the glass is not free to move up and down, the motor will overload and trip the integral circuit breaker. To determine if the glass is free, disconnect the regulator plate from the glass. Then slide the window up and down by hand.

There is an alternate method to check if the glass is free. Position the glass between the up and down stops. Then, shake the glass in the door. Check that the glass can be moved slightly from side to side, front to rear, and up and down. Then check that the glass is not bound tight in the tracks. If the glass is free, proceed to the Door Module diagnosis in this group. If the glass is not free, refer to Group 23 - Body for the door window glass and hardware service and adjustment procedures.

CIRCUIT BREAKER

For circuit descriptions and diagrams, refer to 8W-60 - Power Windows in Group 8W - Wiring Diagrams.

(1) Locate the circuit breaker in the junction block. Pull out the circuit breaker slightly, but be sure that the terminals still contact the terminals in the junction block cavities.

(2) Connect the negative lead of a 12-volt DC voltmeter to a good ground.

(3) With the voltmeter positive lead, check both terminals of the circuit breaker for battery voltage.

If only one terminal has battery voltage, the circuit breaker is faulty and must be replaced. If neither terminal has battery voltage, repair the open circuit from the Power Distribution Center (PDC) as required. If the circuit breaker checks OK, but no power windows operate, see the diagnosis for Power Window System in this group.

DOOR MODULE

NOTE: The following tests may not prove conclusive in the diagnosis of this component. The most reliable, efficient, and accurate means to diagnose this system involves the use of a DRB scan tool and the proper Diagnostic Procedures manual.

If the problem being diagnosed is a rear door window that does not operate from the rear door switch, but does operate from the master switch on the driver side front door, go to the diagnosis for Power Window Switch in this group. If the problem is a passenger side front or rear window that operates from the switch on that door, but does not operate from

DIAGNOSIS AND TESTING (Continued)

the master switch on the driver side front door, use a DRB scan tool and the proper Diagnostic Procedures manual to diagnose the circuitry of both door modules and the CCD data bus. For circuit descriptions and diagrams, refer to 8W-60 - Power Windows in Group 8W - Wiring Diagrams.

(1) Disconnect and isolate the battery negative cable. Remove the front door trim panel as described in this group. Go to Step 2.

(2) Check the 12-way door module wire harness connector to see that it is fully seated in the door module receptacle. If OK, go to Step 3. If not OK, install the wire harness connector properly.

(3) Unplug the 12-way door module wire harness connector from the door module. Check for continuity between the ground circuit cavity of the door module wire harness connector and a good ground. There should be continuity. If OK, go to Step 4. If not OK, repair the open circuit as required.

(4) Connect the battery negative cable. Check for battery voltage at the fused B(+) circuit cavity of the 12-way door module wire harness connector. If OK, go to Step 5. If not OK, repair the open circuit as required.

(5) If the inoperative window is on a front door, go to Step 6. If the inoperative window is on a rear door go to Step 9.

(6) Disconnect and isolate the battery negative cable. Unplug the inoperative power window motor wire harness connector. Check for continuity between the front window driver up circuit cavity of the 12-way door module wire harness connector and a good ground. Repeat the check for the front window driver down circuit cavity of the door module wire harness connector. In each case there should be no continuity. If OK, go to Step 7. If not OK, repair the short circuit as required.

(7) Check for continuity between the front window driver up circuit cavities of the 12-way door module wire harness connector and the power window motor wire harness connector. Repeat the check for the front window driver down circuit cavities. In each case there should be continuity. If OK, go to Step 8. If not OK, repair the open circuit as required.

(8) Plug the 12-way door module wire harness connector back into the door module. Connect the battery negative cable. Connect the probes of a reversible DC digital voltmeter to the door module side of the power window motor wire harness connector. Observe the voltmeter while actuating the switch in the up and down directions. There should be battery voltage for as long as the switch is held in both the up and down positions, and no voltage in the neutral position. If OK, see the diagnosis for Power Window Motors in this group. If not OK, replace the faulty door module.

(9) Disconnect and isolate the battery negative cable. Remove the rear door power window switch as described in this group. Check the rear door power window switch continuity as described in this group. If OK, go to Step 10. If not OK, replace the faulty switch.

(10) Plug the rear door power window switch into the wire harness connector. Unplug the inoperative power window motor wire harness connector. Check for continuity between the rear window driver up circuit cavity of the 12-way door module wire harness connector and a good ground. Repeat the check for the rear window driver down circuit cavity. In each case there should be no continuity. If OK, go to Step 11. If not OK, repair the short circuit as required.

(11) Check for continuity between the rear window driver up circuit cavities of the 12-way door module wire harness connector and the power window motor wire harness connector. Repeat the check for the rear window driver down circuit cavities. In each case there should be continuity. If OK, go to Step 12. If not OK, repair the open circuit as required.

NOTE: The door module feeds battery voltage to both terminals of the rear door power window motors when the power window lockout switch is in the Unlock position, until the master window switch on the driver side front door is actuated. The door module feeds ground to both terminals of the rear door power window motor when the power window lockout switch is in the Lock position, until the master window switch on the driver side front door is actuated.

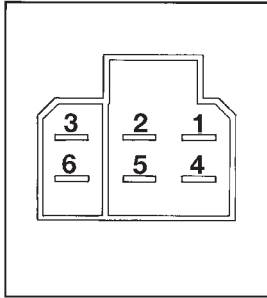
(12) Plug the 12-way door module wire harness connector back into the door module. Connect the battery negative cable. Check for battery voltage at each cavity of the switch side of the power window motor wire harness connector. Each cavity should have battery voltage when the power window switch is in the neutral position. Each cavity should also have battery voltage in one other switch position, either up or down, and zero volts with the switch in the opposite position. If OK, go to the Power Window Motor diagnosis in this group. If not OK, replace the faulty door module.

POWER WINDOW SWITCH

The diagnosis found here applies only to the rear door power window switches. For diagnosis of the front door power window switches, see Door Module in this group. If the problem being diagnosed is an inoperative power window switch illumination lamp, but the power window switch operates as designed, replace the faulty switch. For circuit descriptions and diagrams, refer to 8W-60 - Power Windows in Group 8W - Wiring Diagrams.

DIAGNOSIS AND TESTING (Continued)

- (1) Disconnect and isolate the battery negative cable.
- (2) Remove the power window switch from the rear door trim panel as described in this group.
- (3) Carefully unplug the power window switch from the wire harness connector.
- (4) Check the power window switch continuity in each position, as shown in the chart (Fig. 1). If OK, see the Power Window Motor diagnosis in this group. If not OK, replace the faulty switch.



SWITCH POSITION	CONTINUITY BETWEEN
ALL POSITIONS	3 AND 6
OFF	1 AND 2
OFF	4 AND 5
FORWARD	1 AND 2
FORWARD	5 AND 6
REARWARD	2 AND 6
REARWARD	4 AND 5

80a13746

Fig. 1 Rear Power Window Switch Continuity

POWER WINDOW MOTOR

For circuit descriptions and diagrams, refer to 8W-60 - Power Windows in Group 8W - Wiring Diagrams. Before you proceed with this diagnosis, confirm proper switch operation. See the Door Module and/or the Power Window Switch diagnosis in this group.

- (1) Remove the door trim panel as described in Door Module (front door) or Power Window Switch (rear door) in this group.
- (2) Unplug the power window motor wire harness connector. Apply 12 volts across the motor terminals to check its operation in one direction. Reverse the connections across the motor terminals to check the operation in the other direction. Remember, if the window is in the full up or full down position, the motor will not operate in that direction by design. If OK, repair the circuits from the motor to the door module or the switch as required. If not OK, replace the faulty motor.
- (3) If the motor operates in both directions, check the operation of the window glass and lift mechanism

through its complete up and down travel. There should be no binding or sticking of the window glass or lift mechanism through the entire travel range. If not OK, refer to Group 23 - Body to check the window glass, tracks, and regulator for sticking, binding, or improper adjustment.

REMOVAL AND INSTALLATION

DOOR MODULE

Before replacing the door module, use a DRB scan tool to determine the current settings for the door module programmable features. These settings should be duplicated in the replacement door module using the DRB scan tool, before returning the vehicle to service.

- (1) Disconnect and isolate the battery negative cable.
- (2) Remove the bezel near the inside door latch release handle by inserting a straight-bladed screwdriver in the notched end of the bezel and prying gently upwards.
- (3) Remove the screw located beneath the bezel that secures the front door trim panel to the inner door panel (Fig. 2).

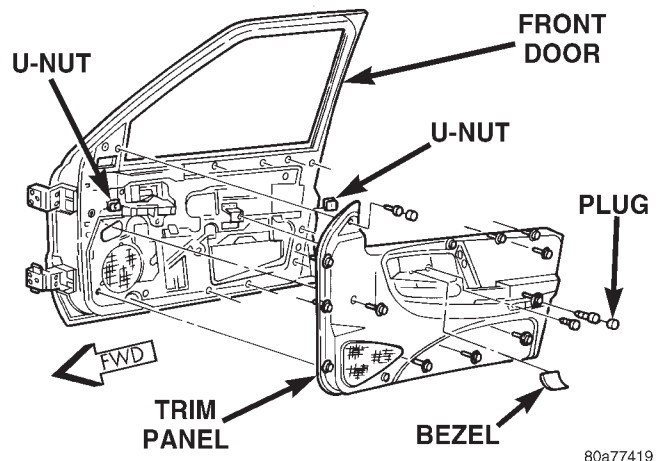


Fig. 2 Front Door Trim Panel Remove/Install

- (4) Remove the trim cap and screw near the rear of the front door armrest.
- (5) Remove the trim cap and screw at the upper front corner of the front door trim panel.
- (6) Remove the screw located above the front door speaker grille on the front door trim panel.
- (7) Using a trim stick or another suitable wide flat-bladed tool, gently pry the front door trim panel away from the door around the perimeter to release the trim panel retainers.

NOTE: To aid in the removal of the trim panel, start at the bottom of the panel.

REMOVAL AND INSTALLATION (Continued)

(8) Pull the front door trim panel away from the inner door panel far enough to access and unplug the wire harness connectors from the door module and, if the vehicle is so equipped, from the front door courtesy lamp.

(9) Remove the five screws that secure the door module to the back of the front door trim panel (Fig. 3).

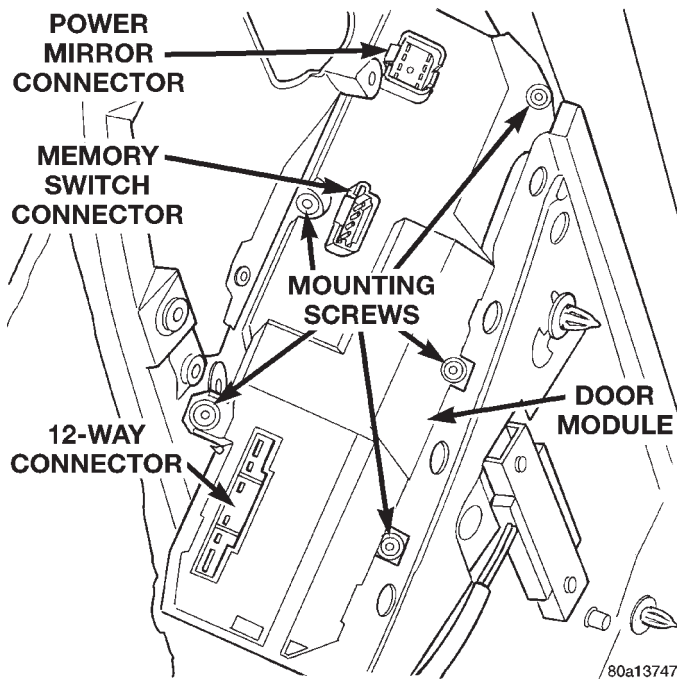


Fig. 3 Door Module Remove/Install

(10) Remove the door module from the trim panel.

(11) Reverse the removal procedures to install. Tighten the mounting screws to 2.2 N·m (20 in. lbs.).

NOTE: If a new door module is installed, the programmable features must be enabled and/or disabled to the customer's preferred settings. Use a DRB scan tool and the proper Diagnostic Procedures manual to perform these operations.

POWER WINDOW SWITCH

(1) Disconnect and isolate the battery negative cable.

(2) Remove the bezel near the inside door latch release handle by inserting a straight-bladed screwdriver in the notched end of the bezel and prying gently upwards.

(3) Remove the screw located beneath the bezel that secures the rear door trim panel to the inner door panel (Fig. 4).

(4) Remove the trim cap and screw near the rear of the rear door armrest.

(5) Using a trim stick or another suitable wide flat-bladed tool, gently pry the rear door trim panel

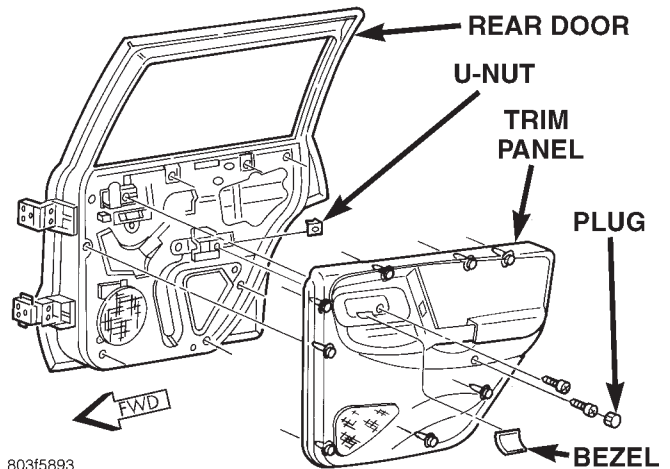


Fig. 4 Rear Door Trim Panel Remove/Install

away from the door around the perimeter to release the trim panel retainers.

NOTE: To aid in the removal of the trim panel, start at the bottom of the panel.

(6) Pull the rear door trim panel away from the inner door panel far enough to access and unplug the wire harness connector from the power window switch.

(7) Unsnap the power window switch from the receptacle on the back side of the rear door trim panel (Fig. 5).

(8) Reverse the removal procedures to install. Tighten the trim panel mounting screws to 1.3 N·m (12 in. lbs.).

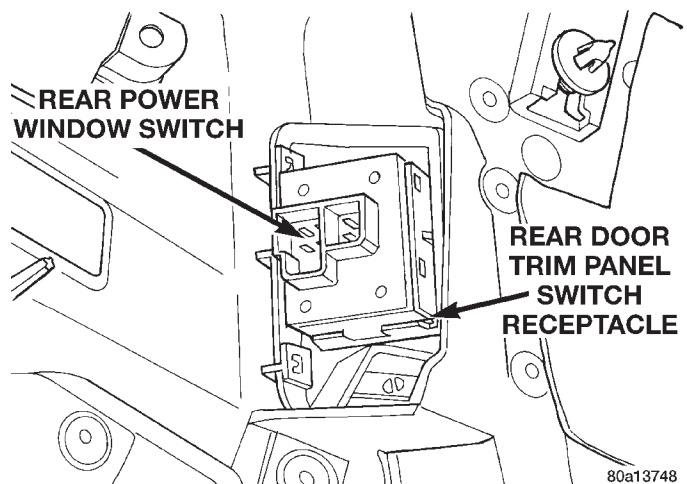


Fig. 5 Rear Door Power Window Switch Remove/Install

REMOVAL AND INSTALLATION (Continued)**POWER WINDOW MOTOR****FRONT DOOR**

(1) Disconnect and isolate the battery negative cable.

(2) Remove the front door window regulator from the front door and place the unit on a work bench. See Front Door Window Regulator in Group 23 - Body for the procedures.

(3) Remove the screws that secure the power window motor to the front door window regulator.

(4) Remove the power window motor from the front door window regulator.

(5) Reverse the removal procedures to install. Tighten the power window motor mounting screws to 5 N·m (45 in. lbs.).

REAR DOOR

(1) Disconnect and isolate the battery negative cable.

(2) Remove the rear door window regulator from the rear door and place the unit on a work bench. See Rear Door Window Regulator in Group 23 - Body for the procedures.

(3) Remove the screws that secure the power window motor to the rear door window regulator.

(4) Remove the power window motor from the rear door window regulator.

(5) Reverse the removal procedures to install. Tighten the power window motor mounting screws to 5 N·m (45 in. lbs.).

POWER MIRROR SYSTEMS

CONTENTS

	page		page
AUTOMATIC DAY/NIGHT MIRROR	6	OUTSIDE POWER MIRRORS	1

OUTSIDE POWER MIRRORS

INDEX

	page		page
GENERAL INFORMATION		DIAGNOSIS AND TESTING	
INTRODUCTION	1	POWER MIRROR SYSTEM	3
MEMORY SYSTEM	1	POWER MIRROR	3
DESCRIPTION AND OPERATION		REMOVAL AND INSTALLATION	
DOOR MODULE	2	DOOR MODULE	4
POWER MIRROR SWITCH	2	POWER MIRROR	5
POWER MIRROR	2		

GENERAL INFORMATION

INTRODUCTION

Power operated and heated outside rear view mirrors are standard factory-installed equipment on this model. Following are general descriptions of the major components in the power mirror system.

Refer to 8W-62 - Power Mirrors in Group 8W - Wiring Diagrams for complete circuit descriptions and diagrams. Refer to the owner's manual for more information on the features and use of this system.

MEMORY SYSTEM

An electronic memory system is an available option on this model. The memory system is able to store and recall the driver side power seat positions (including power lumbar and recliner positions), and both outside power mirror positions for two drivers. For vehicles with a radio connected to the Chrysler Collision Detection (CCD) data bus network, the memory system is also able to store and recall ten radio station presets (including last station tuned) for two drivers. The memory system will automatically return to all of these settings when the corresponding button (Driver 1 or 2) of the memory switch on the driver side front door trim panel is depressed, or when the doors are unlocked using the corresponding (Driver 1 or 2) Remote Keyless Entry (RKE) transmitter.

The Driver Door Module (DDM) receives hard-wired input from the memory set/select switch on the driver side front door trim panel. The DDM also receives messages on the CCD data bus from the RKE receiver in the Passenger Door Module (PDM) for the memory select function. The DDM processes these inputs and sends messages to the PDM, the Memory Seat Module (MSM), and the radio (if CCD data bus capable) on the CCD data bus for memory recall.

The CCD data bus network allows the sharing of sensor information. This helps to reduce wire harness complexity, reduce internal controller hardware, and reduce component sensor current loads. At the same time, this system provides increased reliability, enhanced diagnostics, and allows the addition of many new feature capabilities.

This group covers only the conventional diagnostic procedures for the power mirror system components. For diagnosis of the memory system, the use of a DRB scan tool and the proper Diagnostic Procedures manual are recommended. For additional information on the features and functions of the memory system, refer to the owner's manual in the vehicle glove box.

DESCRIPTION AND OPERATION

POWER MIRROR

The power mirrors are connected to battery feed at all times. Each mirror head contains two electric motors, two drive mechanisms, an electric heating element, and the mirror glass. If the vehicle is equipped with the optional memory system, each mirror head also contains both a horizontal and a vertical motor position sensor. One motor and drive controls mirror up-and-down movement, and the other controls right-and-left movement.

The power mirrors are equipped with a standard equipment electric heating grid located behind the mirror glass. This heating grid is energized or de-energized by the Driver Door Module (DDM) or Passenger Door Module (PDM) in response to messages placed on the Chrysler Collision Detection (CCD) data bus by the Body Control Module (BCM). Refer to Group 8N - Electrically Heated Systems for more information on the operation of the rear window defogger system.

An optional driver side outside electrochromic mirror is able to automatically change its reflectance level. This mirror is controlled by the circuitry of the automatic day/night inside rear view mirror. A thin layer of electrochromic material between two pieces of conductive glass make up the face of the mirror. Two photocell sensors on the inside rear view mirror are used to monitor light levels and adjust the reflectance of both the inside and driver side outside mirrors. This change in reflectance helps to reduce the glare of headlamps approaching the vehicle from the rear. Refer to the Automatic Day/Night Mirror section of this group for more information on the operation of this system.

The power mirror assembly cannot be repaired. Only the mirror glass and glass case are serviced separately. If any other component of the power mirror unit is faulty or damaged, the entire mirror head assembly must be replaced.

POWER MIRROR SWITCH

Both the right and left power outside mirrors are controlled by a single multi-function switch unit located on the driver side front door trim panel. This switch unit is integral to the Driver Door Module (DDM).

A selector switch is moved right (right mirror control), left (left mirror control), or center to turn the power outside mirror control off. Then one of four directional control buttons is depressed to control movement of the selected mirror up, down, right, or left.

The power mirror switch cannot be repaired and, if faulty or damaged, the entire DDM unit must be replaced.

DOOR MODULE

A Driver Door Module (DDM) and a Passenger Door Module (PDM) are used on this model to control and integrate many of the electronic features and functions on the vehicle. Each door module contains the power mirror control logic for the mirror on its respective door. The DDM also houses the power mirror switch.

The DDM and PDM communicate with each other, and with other vehicle modules on the Chrysler Collision Detection (CCD) data bus network. The CCD data bus network allows the sharing of sensor information. This helps to reduce wire harness complexity, internal controller hardware, and component sensor current loads. At the same time, this system provides increased reliability, enhanced diagnostics, and allows the addition of many new feature capabilities.

Each door module controls the positioning of its respective outside mirror through hard-wired outputs to that mirror. When the power mirror switch on the DDM is used to position the passenger side outside mirror, the DDM sends mirror positioning messages to the PDM on the CCD data bus. The PDM then moves the passenger side mirror accordingly.

Both the PDM and DDM respond to the defogger switch status messages sent by the Body Control Module (BCM) on the CCD data bus to control the heater elements of their respective mirrors. Refer to Group 8N - Electrically Heated Systems for more information on this feature.

On models equipped with the optional memory system, each door module also receives a hard-wired input from the two power mirror motor position sensors integral to the mirror. The door module then stores the Driver 1 and 2 mirror position information for its respective mirror. When the DDM receives a Driver 1 or 2 signal from the memory switch on the driver side front door trim panel or from the Remote Keyless Entry (RKE) receiver in the PDM, the DDM positions the driver side mirror and sends a memory recall message back to the PDM on the CCD data bus to position the passenger side mirror.

For diagnosis of the DDM, PDM, or the CCD data bus network, a DRB scan tool and the proper Diagnostic Procedures manual are recommended. The DDM and the PDM cannot be repaired and, if damaged or faulty, they must be replaced.

DIAGNOSIS AND TESTING

POWER MIRROR SYSTEM

If only one power mirror is inoperative, or partially inoperative, see the tests under Power Mirror in this group. If both power mirrors are inoperative, proceed as follows. For circuit descriptions and diagrams, refer to 8W-62 - Power Mirrors in Group 8W - Wiring Diagrams.

NOTE: The following tests may not prove conclusive in the diagnosis of this system. The most reliable, efficient, and accurate means to diagnose this system involves the use of a DRB scan tool and the proper Diagnostic Procedures manual.

(1) Check the circuit breaker in the junction block. If OK, go to Step 2. If not OK, replace the faulty circuit breaker.

(2) Check the fuse in the Power Distribution Center (PDC). If OK, go to Step 3. If not OK, repair the shorted circuit or component as required and replace the faulty fuse.

(3) Disconnect and isolate the battery negative cable. Remove the driver side front door trim panel and check the 12-way Driver Door Module (DDM) wire harness connector to see that it is fully seated in the door module receptacle. If OK, go to Step 4. If not OK, install the wire harness connector properly.

(4) Unplug the 12-way wire harness connector from the DDM. Check for continuity between the ground circuit cavity of the DDM wire harness connector and a good ground. There should be continuity. If OK, go to Step 5. If not OK, repair the open circuit as required.

(5) Connect the battery negative cable. Check for battery voltage at the fused B(+) circuit cavity of the DDM wire harness connector. If OK, use a DRB scan tool and the proper Diagnostic Procedures manual to test both door modules and the CCD data bus. If not OK, repair the open circuit as required.

POWER MIRROR

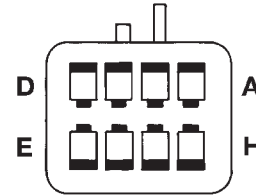
If both power mirrors are inoperative, see the tests under Power Mirror System in this group. If only one power mirror is inoperative, or partially inoperative, refer to the symptom diagnosis as follows. For circuit descriptions and diagrams, refer to 8W-62 - Power Mirrors in Group 8W - Wiring Diagrams.

LIMITED OR NO MIRROR MOVEMENT

(1) Disconnect and isolate the battery negative cable. Remove the front door trim panel on the side of the inoperative mirror.

(2) Unplug the mirror wire harness connector from the door module. Using two jumper wires, test the mirror as shown in the Mirror Test chart (Fig. 1). If

the mirror tests OK, use a DRB scan tool and the proper Diagnostic Procedures manual to test the door module and the CCD data bus. If the mirror does not test OK, replace the faulty mirror.



POWER MIRROR HARNESS CONNECTOR		
APPLY 12 VOLTS TO:	APPLY GROUND TO:	MIRROR REACTION
A	G	LEFT
G	A	RIGHT
H	G	UP
G	H	DOWN

80a1374e

Fig. 1 Mirror Test

NO MIRROR HEAT

If both mirror heaters are inoperative, refer to Group 8N - Electrically Heated Systems to test the Rear Defogger System.

(1) Disconnect and isolate the battery negative cable. Remove the front door trim panel on the side of the inoperative mirror.

(2) Unplug the mirror wire harness connector from the door module. Check for continuity between the heater switched ground circuit cavity and the heater 12V supply circuit cavity of the mirror wire harness connector. There should be continuity. If OK, use a DRB scan tool and the proper Diagnostic Procedures manual to test the door module and the CCD data bus. If not OK, replace the faulty mirror.

NO MIRROR DIMMING (Driver Side Only)

(1) Test the operation of the Automatic Day/Night Mirror as described in this group. If OK, go to Step 2. If not OK, repair the automatic day/night mirror unit as necessary before you proceed.

(2) Disconnect and isolate the battery negative cable. Remove the driver side front door trim panel.

(3) Unplug the 2-way electrochromic mirror wire harness connector from the driver side outside power mirror. Connect a voltmeter to the door half of the electrochromic mirror wire harness connector. Perform the automatic day/night mirror test as described in this group, while observing the voltmeter.

DIAGNOSIS AND TESTING (Continued)

ter. A voltmeter reading of 1.45 ± 0.05 volts indicates a proper dimming signal is being received at the electrochromic mirror wire harness connector. If OK, replace the faulty power mirror. If not OK, repair the circuits to the automatic day/night mirror as required.

NO MIRROR MEMORY

For diagnosis of the memory system, the use of a DRB scan tool and the proper Diagnostic Procedures manual are recommended.

REMOVAL AND INSTALLATION

DOOR MODULE

Before replacing the door module, use a DRB scan tool to determine the current settings for the door module programmable features. These settings should be duplicated in the replacement door module using the DRB scan tool, before returning the vehicle to service.

(1) Disconnect and isolate the battery negative cable.

(2) Remove the bezel near the inside door latch release handle by inserting a straight-bladed screwdriver in the notched end of the bezel and prying gently upwards.

(3) Remove the screw located beneath the bezel that secures the front door trim panel to the inner door panel (Fig. 2).

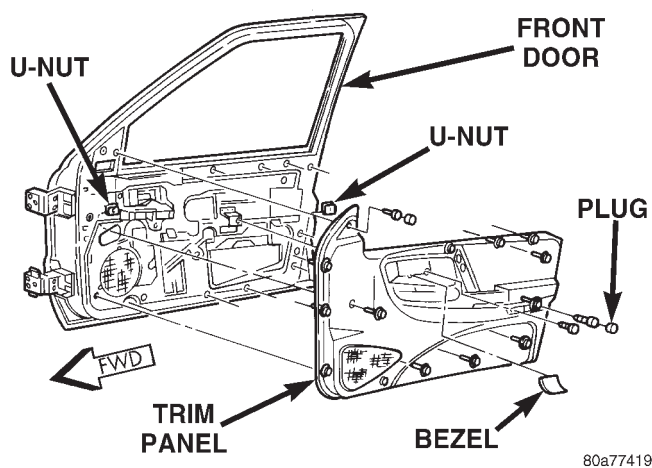


Fig. 2 Front Door Trim Panel Remove/Install

(4) Remove the trim cap and screw near the rear of the front door armrest.

(5) Remove the trim cap and screw at the upper front corner of the front door trim panel.

(6) Remove the screw located above the front door speaker grille on the front door trim panel.

(7) Using a trim stick or another suitable wide flat-bladed tool, gently pry the front door trim panel away from the door around the perimeter to release the trim panel retainers.

NOTE: To aid in the removal of the trim panel, start at the bottom of the panel.

(8) Pull the front door trim panel away from the inner door panel far enough to access and unplug the wire harness connectors from the door module and, if the vehicle is so equipped, from the front door courtesy lamp.

(9) Remove the five screws that secure the door module to the back of the front door trim panel (Fig. 3).

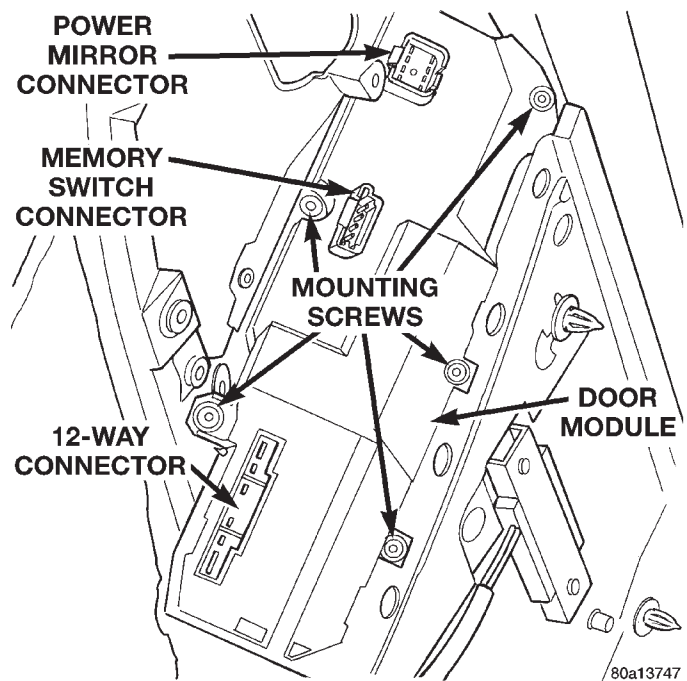


Fig. 3 Door Module Remove/Install

(10) Remove the door module from the trim panel.

(11) Reverse the removal procedures to install. Tighten the mounting screws to 2.2 N·m (20 in. lbs.).

NOTE: If a new door module is installed, the programmable features must be enabled and/or disabled to the customer's preferred settings. Use a DRB scan tool and the proper Diagnostic Procedures manual to perform these operations.

REMOVAL AND INSTALLATION (Continued)**POWER MIRROR**

(1) Disconnect and isolate the battery negative cable.

(2) Remove the front door trim panel. See Door Module in this group for the procedures.

(3) Unplug the electrochromic mirror wire harness connector, if the vehicle is so equipped.

(4) Disconnect the power mirror wire harness retainers from the inner door panel.

(5) Remove the mirror flag seal from the door panel (Fig. 4).

(6) Remove the three nuts that secure the mirror to the door.

(7) Remove the mirror from the door.

(8) Reverse the removal procedures to install. Tighten the mirror mounting nuts to 7.4 N·m (65 in. lbs.).

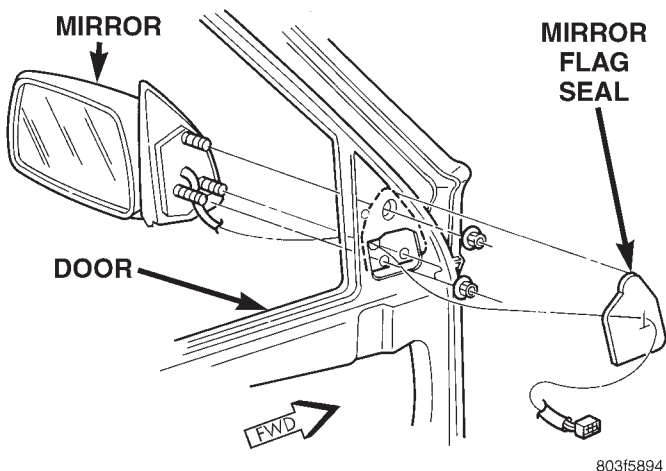


Fig. 4 Power Mirror Remove/Install

AUTOMATIC DAY/NIGHT MIRROR

INDEX

	page		page
GENERAL INFORMATION		DIAGNOSIS AND TESTING	
INTRODUCTION	6	AUTOMATIC DAY/NIGHT MIRROR	6
DESCRIPTION AND OPERATION		REMOVAL AND INSTALLATION	
AUTOMATIC DAY/NIGHT MIRROR	6	AUTOMATIC DAY/NIGHT MIRROR	7

GENERAL INFORMATION

INTRODUCTION

An automatic dimming inside day/night rear view mirror and an automatic dimming driver side outside rear view mirror are available factory-installed options on this model. Following is a general description of this optional equipment. Refer to 8W-44 - Interior Lighting and 8W-62 - Power Mirrors in Group 8W - Wiring Diagrams for complete circuit descriptions and diagrams.

DESCRIPTION AND OPERATION

AUTOMATIC DAY/NIGHT MIRROR

The automatic day/night mirror is able to automatically change its reflectance. A thin layer of electrochromic material between two pieces of conductive glass make up the face of the mirror. Two photocell sensors are used to monitor light levels and adjust the reflectance of the mirror to reduce the glare of headlamps approaching the vehicle from the rear.

The ambient photocell sensor faces forward, to detect the outside light levels. The headlamp sensor faces rearward, to detect the light level received at the rear window side of the mirror. When the difference between the two light levels becomes too great (the light level received at the rear of the mirror is much higher than that at the front of the mirror), the mirror begins to darken.

The mirror switch allows the driver a manual control of whether the automatic dimming feature is operational. When On is selected, the mirror switch is lighted by an integral Light-Emitting Diode (LED). The automatic dimming feature will only operate when the ignition switch is in the On position. The mirror also senses the backup lamp circuit, and will automatically disable its self-dimming feature when-

ever the transmission gear selector is in the Reverse position.

On models with an optional electrochromic driver side outside rear view mirror, the signal to control the dimming of that mirror is generated by the automatic day/night inside rear view mirror circuitry. That signal is then delivered to the driver side outside rear view mirror on a hard-wired circuit.

The automatic day/night mirror cannot be repaired. If faulty or damaged, the entire inside rear view mirror assembly must be replaced.

DIAGNOSIS AND TESTING

AUTOMATIC DAY/NIGHT MIRROR

For circuit descriptions and diagrams, refer to 8W-44 - Interior Lighting or 8W-62 Power Mirrors in Group 8W - Wiring Diagrams.

(1) Check the fuse in the junction block. If OK, go to Step 2. If not OK, repair the shorted circuit or component as required and replace the faulty fuse.

(2) Turn the ignition switch to the On position. Check for battery voltage at the fuse in the junction block. If OK, go to Step 3. If not OK, repair the open circuit to the ignition switch as required.

(3) Unplug the wire harness connector from the automatic day/night mirror (Fig. 1). Check for battery voltage at the fused ignition switch output circuit cavity of the automatic day/night mirror wire harness connector. If OK, go to Step 4. If not OK, repair the open circuit to the junction block as required.

(4) Turn the ignition switch to the Off position. Check for continuity between the ground circuit cavity of the automatic day/night mirror wire harness connector and a good ground. There should be continuity. If OK, go to Step 5. If not OK, repair the circuit to ground as required.

DIAGNOSIS AND TESTING (Continued)

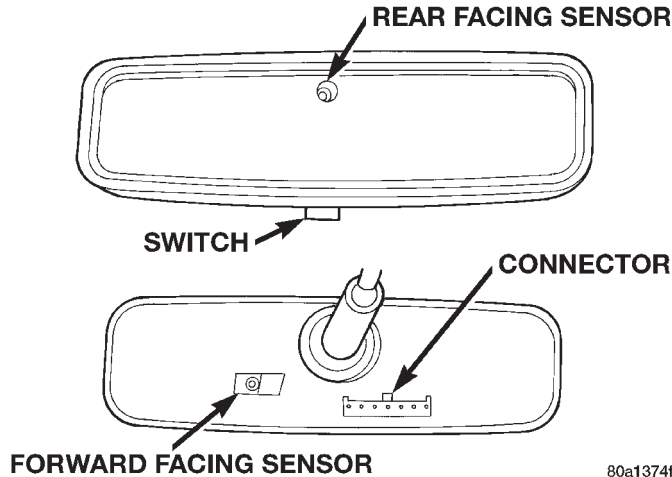


Fig. 1 Automatic Day/Night Mirror

(5) Turn the ignition switch to the On position. Set the parking brake. Place the transmission gear selector lever in the Reverse position. Check for battery voltage at the backup lamp switch output circuit cavity of the automatic day/night mirror wire harness connector. If OK, reinstall the automatic day/night mirror wire harness connector and go to Step 6. If not OK, repair the open circuit as required.

(6) Place the transmission gear selector lever in the Neutral position. Place the automatic day/night mirror switch in the On (LED in the switch is lighted) position. Cover the forward facing ambient photocell sensor to keep out any ambient light.

NOTE: The ambient photocell sensor must be covered completely, so that no light reaches the sensor. Use a finger pressed tightly against the sensor, or cover the sensor completely with electrical tape.

(7) Shine a light into the rearward facing headlamp photocell sensor. The automatic day/night mirror should darken. If OK, go to Step 8. If not OK, replace the faulty mirror unit.

(8) With the mirror darkened, place the transmission gear selector lever in the Reverse position. The automatic day/night mirror should return to its normal reflectance. If not OK, replace the faulty mirror unit.

REMOVAL AND INSTALLATION

AUTOMATIC DAY/NIGHT MIRROR

(1) Disconnect and isolate the battery negative cable.

(2) If the vehicle is so equipped, remove the automatic day/night mirror wire harness cover by grasping the lower portion of the cover and sliding it into the upper portion and off of the mirror base (Fig. 2).

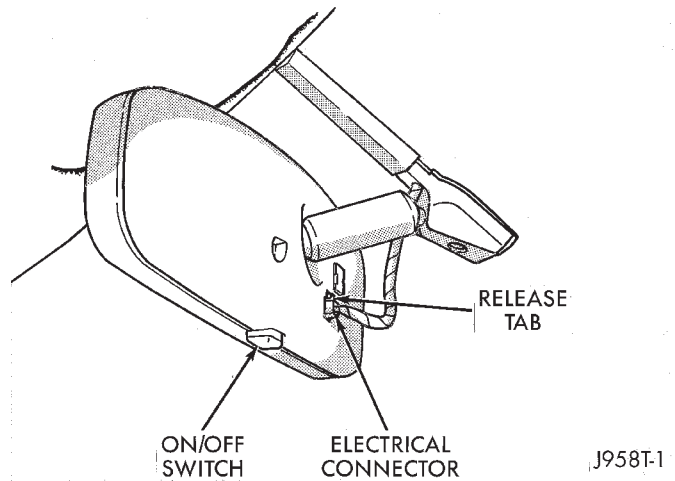


Fig. 2 Automatic Day/Night Mirror Remove/Install - Typical

(3) Unplug the wire harness connector from the automatic day/night mirror.

(4) Remove the set screw that secures the automatic day/night mirror to the windshield support button.

(5) Push the automatic day/night mirror upwards far enough to clear the support button and remove the mirror from the windshield support button.

(6) Reverse the removal procedures to install. Tighten the mounting screw to 1.7 N·m (15 in. lbs.).

CHIME/BUZZER WARNING SYSTEMS

CONTENTS

	page		page
GENERAL INFORMATION		DIAGNOSIS AND TESTING	
INTRODUCTION	1	DRIVER DOOR AJAR SWITCH	2
DESCRIPTION AND OPERATION		DRIVER SEAT BELT SWITCH	2
BODY CONTROL MODULE	1	HEADLAMP SWITCH	3
DRIVER DOOR AJAR SWITCH	1	KEY-IN IGNITION SWITCH	3
DRIVER SEAT BELT SWITCH	2	REMOVAL AND INSTALLATION	
HEADLAMP SWITCH	2	CHIME WARNING SYSTEM SWITCHES	4
KEY-IN IGNITION SWITCH	2		

GENERAL INFORMATION

INTRODUCTION

This group covers the chime warning system, which is standard factory-installed equipment on this model. The chime warning system provides an audible warning to the driver under the following conditions:

- A door is ajar above a critical speed [about 16 kilometers-per-hour (10 miles-per-hour) for the driver side front door, or about 5 kilometers-per-hour (3 miles-per-hour) for any other door]
- Driver side seat belt is not fastened with the ignition switch in the On position
- Head or park lamps are turned on with the ignition switch Off and the driver side front door open
- Key is in the ignition switch with the ignition switch Off and the driver side front door open
- Low fuel warning lamp illumination - less than about one-eighth tank of fuel remaining
- Rear lamp failure
- Turn signal remains on for about 1.6 kilometers (one mile) with no decrease in speed or throttle opening
- Washer level low lamp illumination.

Following are general descriptions of the major components in the chime warning system. Refer to 8W-44 - Interior Lighting or 8W-45 - Body Control Module in Group 8W - Wiring Diagrams for complete circuit descriptions and diagrams.

DESCRIPTION AND OPERATION

BODY CONTROL MODULE

A Body Control Module (BCM) is used on this model to control and integrate many of the electronic functions and features included on the vehicle. The BCM contains a central processing unit and inter-

faces with other modules in the vehicle on the Chrysler Collision Detection (CCD) data bus network.

The CCD data bus network allows the sharing of sensor information. This helps to reduce wire harness complexity, reduce internal controller hardware, and reduce component sensor current loads. At the same time, this system provides increased reliability, enhanced diagnostics, and allows the addition of many new feature capabilities.

One of the functions and features that the BCM supports is the chime warning system. The BCM contains a chime tone generator to perform the functions of the chime warning module. The BCM uses hard-wired inputs, internal programming, and CCD data bus chime request message inputs to decide when a chime tone is required.

The BCM is mounted under the driver side outboard end of the instrument panel, behind the instrument panel support armature and below the outboard switch pod. Refer to Group 8E - Instrument Panel Systems for the removal and installation procedures.

This group only covers the diagnosis and service of the hard-wired inputs used by the BCM to determine that a chime tone should be generated. For diagnosis of the BCM, the CCD data bus, or the other electronic modules on the CCD data bus that send chime request messages to the BCM, the use of a DRB scan tool and the proper Diagnostic Procedures manual are recommended. The BCM can only be serviced by an authorized electronic repair station. Refer to the latest Warranty Policies and Procedures manual for a current listing of authorized electronic repair stations.

DRIVER DOOR AJAR SWITCH

The driver door ajar switch is mounted to the driver side front door latch pillar. The switch closes a path to ground for the Body Control Module (BCM) driver front door ajar switch circuit when the driver

DESCRIPTION AND OPERATION (Continued)

door is opened, and opens the ground path when the driver door is closed.

The driver door ajar switch cannot be repaired and, if faulty or damaged, it must be replaced. Refer to Group 8Q - Vehicle Theft/Security Systems for the service procedures.

DRIVER SEAT BELT SWITCH

The driver seat belt switch is integral to the driver seat belt tip-half retractor assembly. The switch is normally closed, providing a ground path to the Body Control Module (BCM) through the seat belt switch sense circuit. The switch monitors the amount of seat belt webbing wound onto the seat belt retractor spool. When the seat belt tip-half webbing is pulled out of the retractor far enough to engage the seat belt buckle-half, the switch opens the ground path.

The driver seat belt switch cannot be repaired and, if faulty or damaged, the entire driver seat belt tip-half and retractor unit must be replaced. Refer to Group 23 - Body for the service procedures.

KEY-IN IGNITION SWITCH

The key-in ignition switch is integral to the ignition switch, which is mounted on the right side of the steering column. It closes a path to ground for the Body Control Module (BCM) when the ignition key is inserted in the ignition lock cylinder. The key-in ignition switch opens the ground path when the key is removed from the ignition lock cylinder.

The key-in ignition switch cannot be repaired and, if faulty or damaged, the entire ignition switch must be replaced. Refer to Group 8D - Ignition Systems for the service procedures.

HEADLAMP SWITCH

The headlamp switch is integral to the outboard switch pod located in the instrument panel, outboard of the steering column. It provides a battery voltage signal to the Body Control Module (BCM) park lamp relay output circuit when the park or head lamps are turned on. The headlamp switch opens the park lamp relay output circuit when the headlamp switch is turned off.

The headlamp switch cannot be repaired and, if faulty or damaged, the outboard switch pod unit must be replaced. Refer to Group 8E - Instrument Panel Systems for the service procedures.

DIAGNOSIS AND TESTING

DRIVER DOOR AJAR SWITCH

For circuit descriptions and diagrams, refer to 8W-45 - Body Control Module in Group 8W - Wiring Diagrams.

WARNING: ON VEHICLES EQUIPPED WITH AIR-BAGS, REFER TO GROUP 8M - PASSIVE RESTRAINT SYSTEMS BEFORE ATTEMPTING ANY STEERING WHEEL, STEERING COLUMN, OR INSTRUMENT PANEL COMPONENT DIAGNOSIS OR SERVICE. FAILURE TO TAKE THE PROPER PRECAUTIONS COULD RESULT IN ACCIDENTAL AIR-BAG DEPLOYMENT AND POSSIBLE PERSONAL INJURY.

(1) Open the driver side front door and note whether the interior lamps light. They should light. If OK, see the diagnosis for the Key-In Ignition Switch or the Headlamp Switch in this group. If not OK, go to Step 2.

(2) Disconnect and isolate the battery negative cable. Unplug the driver door ajar switch from its wire harness connector. Check for continuity between the switch terminal and the switch body. There should be continuity with the switch plunger released, and no continuity with the switch plunger depressed. If OK, go to Step 3. If not OK, replace the faulty switch.

(3) Unplug the black 14-way wire harness connector from the Body Control Module (BCM). Check for continuity between the driver door ajar switch wire harness connector and a good ground. There should be no continuity. If OK, go to Step 4. If not OK, repair the short circuit as required.

(4) Check for continuity between the driver side front door ajar switch sense circuit cavities of the driver door ajar switch wire harness connector and the black 14-way BCM wire harness connector. There should be continuity. If OK, use a DRB scan tool and the proper Diagnostic Procedures manual to test the BCM. If not OK, repair the open circuit as required.

DRIVER SEAT BELT SWITCH

For circuit descriptions and diagrams, refer to 8W-45 - Body Control Module in Group 8W - Wiring Diagrams.

WARNING: ON VEHICLES EQUIPPED WITH AIR-BAGS, REFER TO GROUP 8M - PASSIVE RESTRAINT SYSTEMS BEFORE ATTEMPTING ANY STEERING WHEEL, STEERING COLUMN, OR INSTRUMENT PANEL COMPONENT DIAGNOSIS OR SERVICE. FAILURE TO TAKE THE PROPER PRECAUTIONS COULD RESULT IN ACCIDENTAL AIR-BAG DEPLOYMENT AND POSSIBLE PERSONAL INJURY.

(1) Disconnect and isolate the battery negative cable. Unplug the driver seat belt switch wire harness connector from the driver seat belt retractor behind the B pillar trim. Check for continuity between the seat belt switch sense circuit and the

DIAGNOSIS AND TESTING (Continued)

ground circuit cavities of the seat belt retractor half of the driver seat belt switch wire harness connector. There should be continuity with the seat belt webbing retracted, and no continuity with the seat belt webbing extracted far enough to buckle the seat belt. If OK, go to Step 2. If not OK, replace the faulty seat belt tip-half and retractor assembly.

(2) Check for continuity between the ground circuit cavity in the body half of the driver seat belt switch wire harness connector and a good ground. There should be continuity. If OK, go to Step 3. If not OK, repair the circuit to ground as required.

(3) Unplug the black 14-way wire harness connector from the Body Control Module (BCM). Check for continuity between the seat belt switch sense circuit cavity in the body half of the driver seat belt switch wire harness connector and a good ground. There should be no continuity. If OK, go to Step 4. If not OK, repair the short circuit as required.

(4) Check for continuity between the seat belt switch sense circuit cavities in the body half of the driver seat belt switch wire harness connector and the 14-way BCM wire harness connector. There should be continuity. If OK, use a DRB scan tool and the proper Diagnostic Procedures manual to test the BCM. If not OK, repair the open circuit as required.

KEY-IN IGNITION SWITCH

For circuit descriptions and diagrams, refer to 8W-40 - Instrument Cluster or 8W-44 - Interior Lighting in Group 8W - Wiring Diagrams.

WARNING: ON VEHICLES EQUIPPED WITH AIR-BAGS, REFER TO GROUP 8M - PASSIVE RESTRAINT SYSTEMS BEFORE ATTEMPTING ANY STEERING WHEEL, STEERING COLUMN, OR INSTRUMENT PANEL COMPONENT DIAGNOSIS OR SERVICE. FAILURE TO TAKE THE PROPER PRECAUTIONS COULD RESULT IN ACCIDENTAL AIR-BAG DEPLOYMENT AND POSSIBLE PERSONAL INJURY.

(1) Disconnect and isolate the battery negative cable. Unplug the key-in ignition switch wire harness connector from the ignition switch. Check for continuity between the key-in ignition switch sense and ground terminals of the key-in ignition switch. There should be continuity with the key inserted in the ignition lock cylinder, and no continuity with the key removed from the ignition lock cylinder. If OK, go to Step 2. If not OK, replace the faulty ignition switch assembly.

(2) Check for continuity between the ground circuit cavity of the key-in ignition switch wire harness connector and a good ground. There should be continuity. If OK, go to Step 3. If not OK, repair the open circuit to ground as required.

(3) Unplug the black 24-way wire harness connector from the Body Control Module (BCM). Check for continuity between the key-in ignition switch sense circuit cavity of the key-in ignition switch wire harness connector and a good ground. There should be no continuity. If OK, go to Step 4. If not OK, repair the short circuit as required.

(4) Check for continuity between the key-in ignition switch sense circuit cavities of the key-in ignition switch wire harness connector and the black 24-way BCM wire harness connector. There should be continuity. If OK, use a DRB scan tool and the proper Diagnostic Procedures manual to test the BCM. If not OK, repair the open circuit as required.

HEADLAMP SWITCH

If the park lamps are inoperative, refer to Group 8L - Lamps for diagnosis. If the park lamps operate, but there is no chime warning issued with the driver side front door open, proceed as follows. For circuit descriptions and diagrams, refer to 8W-40 - Instrument Cluster or 8W-44 - Interior Lighting in Group 8W - Wiring Diagrams.

WARNING: ON VEHICLES EQUIPPED WITH AIR-BAGS, REFER TO GROUP 8M - PASSIVE RESTRAINT SYSTEMS BEFORE ATTEMPTING ANY STEERING WHEEL, STEERING COLUMN, OR INSTRUMENT PANEL COMPONENT DIAGNOSIS OR SERVICE. FAILURE TO TAKE THE PROPER PRECAUTIONS COULD RESULT IN ACCIDENTAL AIR-BAG DEPLOYMENT AND POSSIBLE PERSONAL INJURY.

(1) Disconnect and isolate the battery negative cable. Remove the outboard switch pod from the instrument panel. Unplug the headlamp switch wire harness connector. Unplug the black 24-way wire harness connector from the Body Control Module (BCM). Check for continuity between the park lamp relay output circuit cavity of the headlamp switch wire harness connector and a good ground. There should be no continuity. If OK, go to Step 2. If not OK, repair the short circuit as required.

(2) Check for continuity between the park lamp relay output circuit cavities of the headlamp switch wire harness connector and the black 24-way BCM wire harness connector. There should be continuity. If OK, use a DRB scan tool and the proper Diagnostic Procedures manual to test the BCM. If not OK, repair the open circuit as required.

REMOVAL AND INSTALLATION

CHIME WARNING SYSTEM SWITCHES

Service procedures for the various hard-wired switches used in the chime warning system can be found in the appropriate group as follows:

- Driver door ajar switch - refer to Group 8Q - Vehicle Theft/Security Systems

- Driver seat belt switch - refer to Group 23 - Body

- Headlamp switch - refer to Group 8E - Instrument Panel Systems

- Key-in ignition switch - refer to Group 8D - Ignition Systems.

OVERHEAD CONSOLE SYSTEMS

CONTENTS

	page		page
GENERAL INFORMATION			
INTRODUCTION	1	COMPASS DEMAGNETIZING	5
DESCRIPTION AND OPERATION			
COMPASS	2	COMPASS VARIATION ADJUSTMENT	4
GARAGE DOOR OPENER STORAGE BIN	2	REMOVAL AND INSTALLATION	
READING AND COURTESY LAMP	2	AMBIENT TEMPERATURE SENSOR	8
SUNGLASSES STORAGE BIN	3	GARAGE DOOR OPENER STORAGE BIN DOOR	8
THERMOMETER	2	OVERHEAD CONSOLE	6
TRIP COMPUTER	1	PUSH BUTTON MODULE	8
DIAGNOSIS AND TESTING			
THERMOMETER	4	READING AND COURTESY LAMP BULB	8
TRIP COMPUTER, COMPASS, AND THERMOMETER DISPLAY MODULE	3	SUNGLASSES STORAGE BIN	8
SERVICE PROCEDURES			
COMPASS CALIBRATION	4	TRIP COMPUTER, COMPASS, AND THERMOMETER DISPLAY MODULE	7
SPECIAL TOOLS			
		COMPASS	9

GENERAL INFORMATION

INTRODUCTION

Two overhead consoles featuring a mini trip computer, an electronic compass, and an outside ambient temperature thermometer are available factory-installed options on this model. A long version of the overhead console is used on models without a power sunroof option. A short version of the overhead console is used on models with a power sunroof option.

The long overhead console also includes two front-mounted and two rear-mounted reading and courtesy lamps, a garage door opener storage bin, and a sunglasses storage bin. The short overhead console also includes two reading and courtesy lamps and houses the power sunroof switch.

Following are general descriptions of the major components used in the overhead console. Refer to 8W-49 - Overhead Console in Group 8W - Wiring Diagrams for complete circuit descriptions and diagrams.

DESCRIPTION AND OPERATION

TRIP COMPUTER

A mini trip computer is available on this model to provide several electronic functions and features. The trip computer contains a central processing unit and

interfaces with other modules in the vehicle on the Chrysler Collision Detection (CCD) data bus network.

The CCD data bus network allows the sharing of sensor information. This helps to reduce wire harness complexity, reduce internal controller hardware, and reduce component sensor current loads. At the same time, this system provides increased reliability, enhanced diagnostics, and allows the addition of many new feature capabilities.

Some of the functions and features that the trip computer supports and/or controls, include the following display options:

- Compass and temperature
- Trip odometer (ODO)
- Average fuel economy (AVG ECO)
- Instant fuel economy (ECO)
- Distance to empty (DTE)
- Elapsed time (ET)
- Blank display.

Momentarily depressing and releasing the Step button when the ignition switch is in the On position will cause the overhead console display to step sequentially through the listed display options. Momentarily depressing and releasing the U.S./Metric button toggles the display between U.S. and Metric measurements. For more information on the trip computer features and functions, refer to the owner's manual in the vehicle glove box.

The push button (Step and U.S./Metric) switch module in the overhead console is hard-wired to the

DESCRIPTION AND OPERATION (Continued)

trip computer. The compass flux-gate unit is integral to the trip computer, compass, and thermometer display module unit. Data input for all other trip computer functions is received through CCD data bus messages. The trip computer uses its internal programming and all of these inputs to calculate and display the requested data. If the data displayed is incorrect, perform the self-diagnostic tests as described in this group. If these tests prove inconclusive, the use of a DRB scan tool and the proper Diagnostic Procedures manual are recommended for further testing of the trip computer and the CCD data bus.

The trip computer, compass, and thermometer display module cannot be repaired, and are only available for service as a unit. If faulty, the complete module must be replaced. The push button (Step and U.S./Metric) switch module is serviced separately.

COMPASS

The compass will display the direction in which the vehicle is pointed using the eight major compass headings (Examples: north is N, northeast is NE). It does not display the headings in actual degrees.

The self-calibrating compass unit requires no adjusting in normal use. The only calibration that may prove necessary is to drive the vehicle in three complete circles, on level ground, in not less than 48 seconds. This will reorient the compass unit to its vehicle.

The compass unit also will compensate for magnetism the body of the vehicle may acquire during normal use. However, avoid placing anything magnetic directly on the roof of the vehicle. Magnetic mounts for an antenna, a repair order hat, or a funeral procession flag can exceed the compensating ability of the compass unit if placed on the roof panel. Magnetic bit drivers used on the fasteners that hold the assembly to the roof header can also affect compass operation. If the vehicle roof should become magnetized, the demagnetizing and calibration procedures found in this group may be required to restore proper compass operation.

The compass, trip computer, and thermometer display module cannot be repaired, and are only available for service as a unit. If faulty, the complete module must be replaced. The push button (Step and U.S./Metric) switch module is serviced separately.

THERMOMETER

The thermometer displays the outside ambient temperature. The temperature display can be changed from Fahrenheit to Celsius using the U.S./Metric button, located just rearward of the display module. The displayed temperature is not an instant reading of conditions, but an average temperature. It

may take the thermometer display several minutes to respond to a major temperature change, such as driving out of a heated garage into winter temperatures.

When the ignition switch is turned to the Off position, the last displayed temperature reading stays in the thermometer unit memory. When the ignition switch is turned to the On position again, the thermometer will display the memory temperature for one minute; then update the display to the current average temperature reading within five minutes.

The thermometer function is supported by an ambient temperature sensor. The sensor is mounted outside the passenger compartment near the front and center of the vehicle and is hard-wired to the Body Control Module (BCM). The BCM sends a temperature status message to the overhead console over the Chrysler Collision Detection (CCD) data bus network. The ambient temperature sensor is available as a separate service item.

The thermometer, compass, and trip computer display module cannot be repaired, and are only available for service as a unit. If faulty, the complete module must be replaced. The push button (Step and U.S./Metric) switch module and ambient temperature sensor are serviced separately.

READING AND COURTESY LAMP

All reading and courtesy lamps located in the overhead console are activated by the door ajar switches. When the doors are closed, the lamps can be individually activated by depressing the corresponding lens.

When a door is open, depressing the lamp lens switches will not turn the lamps off. Refer to Group 8L - Lamps, for diagnosis of the reading and courtesy lamps.

The reading and courtesy lamp lens, and bulbs are available for service replacement. The reading and courtesy lamp holders and switches are only available as part of the overhead console wire harness. If any reading lamp switch is faulty or damaged, the wire harness and all four switches must be replaced.

GARAGE DOOR OPENER STORAGE BIN

A compartment in the long-type overhead console is designed to hold most garage door opener remote control transmitters. The transmitter is mounted within the compartment with an adhesive-backed hook and loop fastener patch.

With the transmitter mounted in the storage bin, adapter pegs located on the front of the storage bin door are selected and mounted on a post near the center of the storage bin door. The peg(s) selected and/or the post must be long enough to depress the button of the transmitter, when the garage door opener storage bin door is depressed. The pegs may

DESCRIPTION AND OPERATION (Continued)

be stacked, if necessary. Refer to the owner's manual in the vehicle glove box for more information.

A transmitter mounting kit including the adhesive-backed hook and loop fastener material and a selection of pegs is available for service. The garage door opener storage bin door assembly is also available for service replacement.

SUNGLASSES STORAGE BIN

A sunglasses storage bin is included in the long-type overhead console. The interior of the bin is lined with a foam rubber padding material to protect the sunglasses from being scratched. This bin features a push/push-type latching mechanism, and a viscous dampening system for a fluid opening action.

The sunglasses storage bin door, latch, viscous damper, hinge spring and housing are available for service only as a complete module. If any part of this unit is faulty or damaged, the entire module must be replaced.

DIAGNOSIS AND TESTING

TRIP COMPUTER, COMPASS, AND THERMOMETER DISPLAY MODULE

If the problem with the trip computer, compass, and thermometer display module is an inaccurate or scrambled display, use the Self-Diagnostic Test procedures. If the problem is incorrect display lighting levels, use a DRB scan tool and the proper Diagnostic Procedures manual to test for the correct dimming message inputs being received from the Body Control Module (BCM) over the Chrysler Collision Detection (CCD) data bus. If the problem is a no-display condition, use the following procedures. For circuit descriptions and diagrams, refer to 8W-49 - Overhead Console in Group 8W - Wiring Diagrams.

(1) Check the fuses in the junction block. If OK, go to Step 2. If not OK, repair the shorted circuit or component as required and replace the faulty fuse(s).

(2) Turn the ignition switch to the On position. Check for battery voltage at the fused ignition switch output fuse in the junction block. If OK, go to Step 3. If not OK, repair the open circuit to the ignition switch as required.

(3) Turn the ignition switch to the Off position. Disconnect and isolate the battery negative cable. Remove the overhead console as described in this group. Check for continuity between the ground circuit cavity of the overhead console wire harness connector and a good ground. There should be continuity. If OK, go to Step 4. If not OK, repair the open circuit to ground as required.

(4) Connect the battery negative cable. Check for battery voltage at the fused B(+) circuit cavity of the overhead console wire harness connector. If OK, go to

Step 5. If not OK, repair the open circuit to the junction block as required.

(5) Turn the ignition switch to the On position. Check for battery voltage at the fused ignition switch output circuit cavity of the overhead console wire harness connector. If OK, proceed to the Self-Diagnostic Test in this group for further diagnosis of the module and the CCD data bus. If not OK, repair the open circuit to the junction block as required.

SELF-DIAGNOSTIC TEST

A self-diagnostic test is used to determine that the trip computer, compass, thermometer, and all of the display module segments are operating properly electrically. Initiate the self-diagnostic test as follows:

(1) With the ignition switch in the Off position, simultaneously press and hold the Step button and the U.S./Metric button.

(2) Turn the ignition switch to the On position.

(3) Continue to hold both buttons until the display module performs a display segment test. In this test, all of the vacuum fluorescent display segments are lighted. This test will:

- a. Verify that all display segments are functional
- b. Check the internal circuitry of the module
- c. Check that all of the CCD data bus messages needed are being received.

(4) Respond to the respective test results as follows. If all tests are passed, the module will automatically return to normal operation.

d. In the display segment test, if any segment should fail to light the unit is faulty and must be replaced.

e. If the internal circuitry test is failed, the module will display "FAIL". If "FAIL" is displayed, the unit is faulty and must be replaced.

f. If the CCD data bus message test is failed, the module will display "CCD". If "CCD" is displayed, the use of a DRB scan tool and the proper Diagnostic Procedures manual are required for further diagnosis.

(5) Momentarily depress and release either button one time to exit the self-diagnostic test mode and return the trip computer, compass, and thermometer display module to normal operation.

NOTE: If the compass functions, but accuracy is suspect, it may be necessary to perform a variation adjustment. This procedure allows the compass unit to accommodate variations in the earth's magnetic field strength, based on geographic location. See the Compass Variation Adjustment procedures, in this group.

DIAGNOSIS AND TESTING (Continued)

NOTE: If the compass reading has blanked out, and only "CAL" appears in the display module, demagnetizing may be necessary to remove excessive residual magnetic fields from the vehicle. See the Compass Demagnetizing procedure, in this group.

THERMOMETER

The thermometer function is supported by a ambient temperature sensor, a wiring circuit, the Body Control Module (BCM), the Chrysler Collision Detection (CCD) data bus, and a portion of the overhead console trip computer, compass, and thermometer display module display. The sensor is mounted outside the passenger compartment near the front and center of the vehicle.

If any portion of the ambient temperature sensor circuit fails, the thermometer display will self-diagnose the circuit. An "SC" (short circuit) will appear in the display in place of the temperature, when the sensor is exposed to temperatures above 55° C (131° F), or if the sensor circuit is shorted. An "OC" (open circuit) will appear in the display in place of the temperature, when the sensor is exposed to temperatures below -40° C (-40° F), or if the sensor circuit is open.

The ambient temperature sensor circuit can also be diagnosed using the following Sensor Test, and Sensor Circuit Test. If the temperature sensor and circuit are confirmed to be OK, but the temperature display is inoperative or incorrect, see the Trip Computer, Compass, and Thermometer Display Module diagnosis in this group. For circuit descriptions and diagrams, refer to 8W-45 - Body Control Module and 8W-49 - Overhead Console in Group 8W - Wiring Diagrams.

SENSOR TEST

(1) Turn the ignition switch to the Off position. Disconnect and isolate the battery negative cable. Unplug the temperature sensor wire harness connector.

(2) Measure the resistance of the temperature sensor. At -40° C (-40° F), the sensor resistance is 336 kilohms. At 55° C (140° F), the sensor resistance is 2.488 kilohms. The sensor resistance should read between these two values. If OK, go to the Sensor Circuit Test. If not OK, replace the faulty sensor.

SENSOR CIRCUIT TEST

(1) Turn the ignition switch to the Off position. Disconnect and isolate the battery negative cable. Unplug the ambient temperature sensor wire harness connector and the black 24-way Body Control Module (BCM) wire harness connector.

(2) Connect a jumper wire between the two terminals in the body half of the sensor wire harness connector.

(3) Check for continuity between the sensor return circuit and the ambient temperature sensor signal circuit cavities of the black 24-way BCM wire harness connector. There should be continuity. If OK, go to Step 4. If not OK, repair the open circuit as required.

(4) Remove the jumper wire from the ambient temperature sensor wire harness connector. Check for continuity between the sensor return circuit cavity of the black 24-way BCM wire harness connector and a good ground. There should be no continuity. If OK, go to Step 5. If not OK, repair the short circuit as required.

(5) Check for continuity between the ambient temperature sensor signal circuit cavity of the black 24-way BCM wire harness connector and a good ground. There should be no continuity. If OK, see the Trip Computer, Compass, and Thermometer Display Module diagnosis in this group. If not OK, repair the short circuit as required.

SERVICE PROCEDURES

COMPASS VARIATION ADJUSTMENT

Variance is the difference between magnetic north and geographic north. In some geographic locations, the difference between magnetic and geographic north is great enough to cause the compass to give false readings. If this problem occurs, the compass variance must be set.

To set the compass variance:

(1) Using the Variance Settings map, find your geographic location and note the zone number (Fig. 1).

(2) Turn the ignition switch to the On position. If the compass/temperature data is not currently being displayed, momentarily depress and release the Step button to step through the display options until you have reached the compass/temperature display.

(3) Depress both the U.S./Metric, and the Step buttons. Hold the buttons down until "VAR" appears in the display. This takes about five seconds.

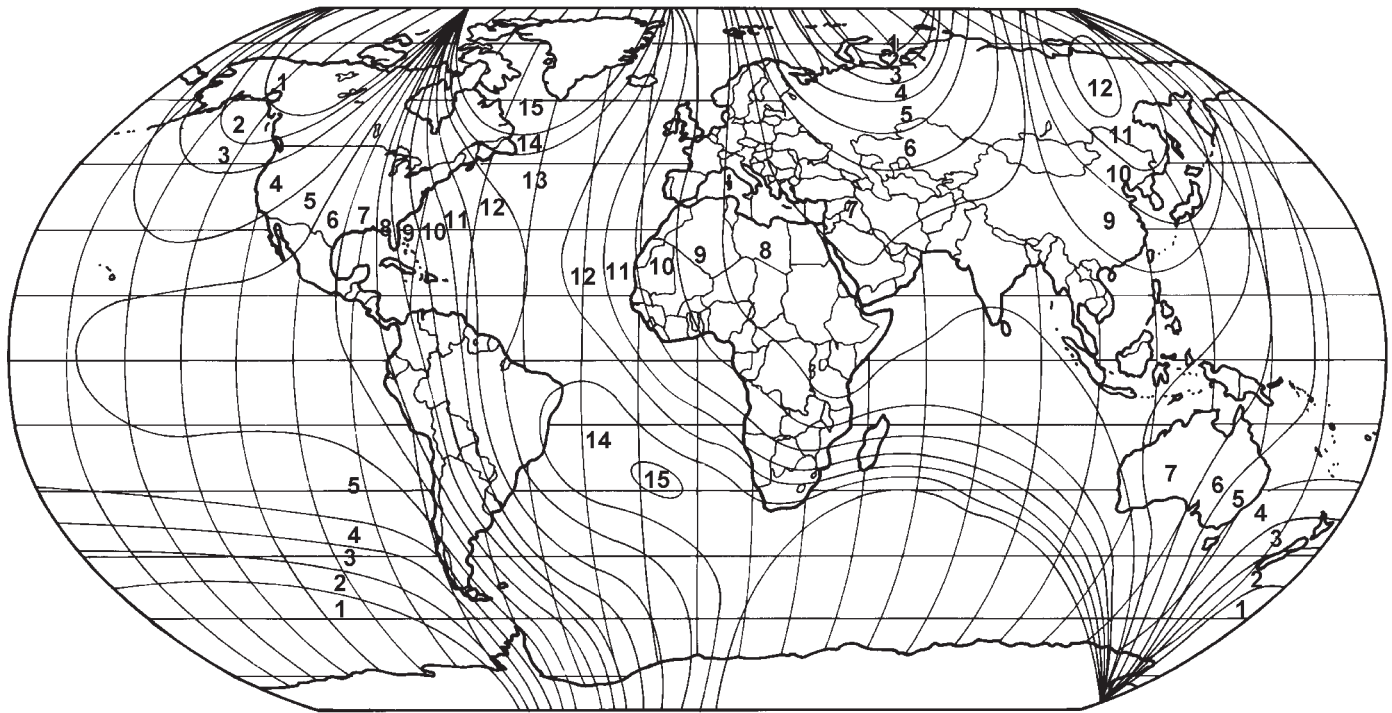
(4) Release both of the buttons. The current variance zone number setting will appear in the display.

(5) Press and release the U.S./Metric button to step through the zone numbers, until the zone number for your geographic location appears in the display.

(6) Press the Step button to enter this zone number into the compass unit memory.

(7) Confirm that the correct directions are now indicated by the compass.

SERVICE PROCEDURES (Continued)



80a13863

Fig. 1 Variance Settings

COMPASS CALIBRATION

CAUTION: Do not place any external magnets, such as magnetic roof mount antennas, in the vicinity of the compass. Do not use magnetic tools when servicing the overhead console.

The electronic compass unit features a self-calibrating design, which simplifies the calibration procedure. This feature automatically updates the compass calibration while the vehicle is being driven. This allows the compass unit to compensate for small changes in the residual magnetism that the vehicle may acquire during normal use. Do not attempt to calibrate the compass near large metal objects such as other vehicles, large buildings, or bridges.

NOTE: Whenever the compass is calibrated manually, the variation number must also be reset. See the Compass Variation Adjustment procedure, in this group.

Calibrate the compass manually as follows:

(1) Start the engine. If the compass/temperature data is not currently being displayed, momentarily depress and release the Step button to step through the display options until you have reached the compass/temperature display.

(2) Depress both the U.S./Metric, and the Step buttons. Hold the buttons down until "CAL" appears in

the display. This takes about ten seconds, and appears about five seconds after "VAR" is displayed.

(3) Release both of the buttons.

(4) Drive the vehicle on a level surface, away from large metal objects, through three or more complete circles in not less than 48 seconds. The "CAL" message will disappear from the display to indicate that the compass is now calibrated.

NOTE: If the "CAL" message remains in the display, either there is excessive magnetism near the compass, or the unit is faulty. Repeat the demagnetizing and calibration procedures at least one more time.

NOTE: If the wrong direction is still indicated in the compass display, the area selected for calibration may be too close to a strong magnetic field. Repeat the calibration procedure in another location.

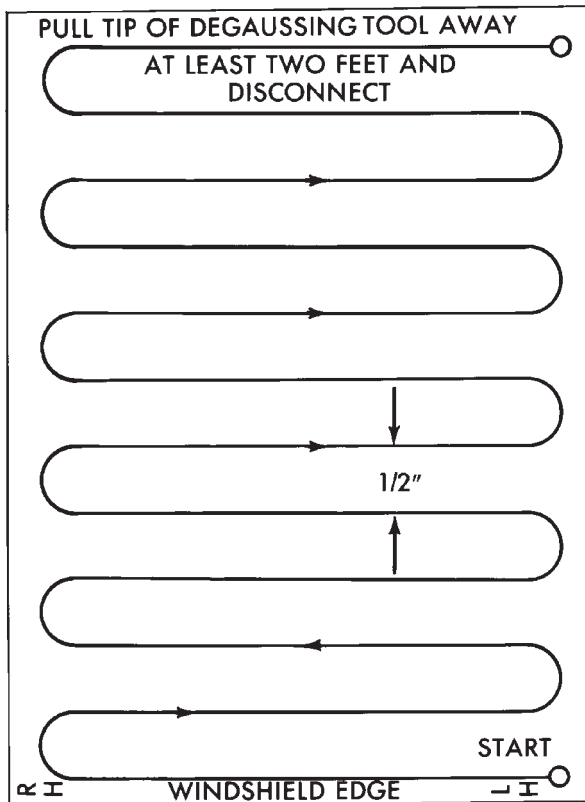
COMPASS DEMAGNETIZING

A degaussing tool (Special Tool 6029) is used to demagnetize, or degauss, the overhead console forward mounting screw(s) and the roof panel. Equivalent units must be rated as continuous duty for 110/115 volts and 60 Hz. They must also have a field strength of over 350 gauss at 7 millimeters (0.25 inch) beyond the tip of the probe.

SERVICE PROCEDURES (Continued)

To demagnetize the roof panel and the overhead console forward mounting screw(s), proceed as follows:

- (1) Be certain the ignition switch is in the Off position, before you begin the demagnetizing procedure.
- (2) Plug in the degaussing tool, while keeping the tool at least 61 centimeters (2 feet) away from the compass unit.
- (3) Slowly approach the head of the overhead console forward mounting screw with the degaussing tool plugged in.
- (4) Contact the head of each screw with the plastic coated tip of the degaussing tool for about two seconds.
- (5) With the degaussing tool still energized, slowly back it away from the screw. When the tip of the tool is at least 61 centimeters (2 feet) from the screw head, unplug the tool.
- (6) Place a piece of paper approximately 22 by 28 centimeters (8.5 by 11 inches), oriented on the vehicle lengthwise from front to rear, on the center line of the roof at the windshield header (Fig. 2). The purpose of the paper is to protect the roof panel from scratches, and to define the area to be demagnetized.



J908E-27

Fig. 2 Roof Demagnetizing Pattern

(7) Plug in the degaussing tool, while keeping the tool at least 61 centimeters (2 feet) away from the compass unit.

(8) Slowly approach the center line of the roof panel at the windshield header, with the degaussing tool plugged in.

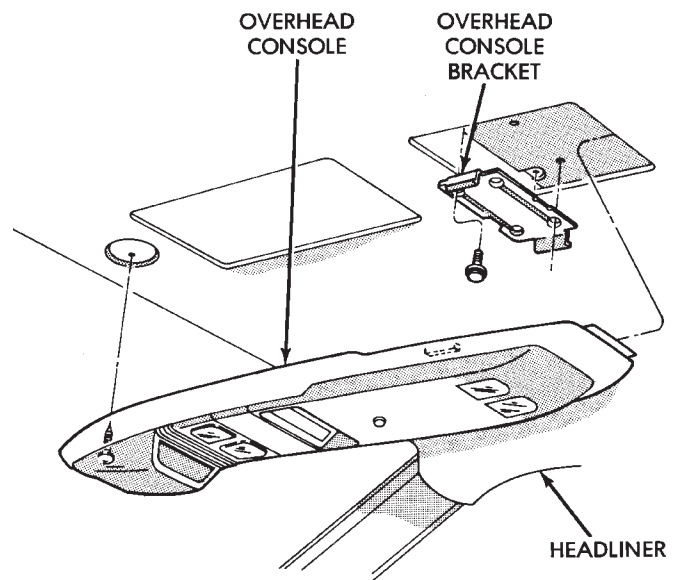
(9) Contact the roof panel with the plastic coated tip of the degaussing tool. Be sure that the template is in place to avoid scratching the roof panel. Using a slow, back-and-forth sweeping motion, and allowing 13 millimeters (0.50 inch) between passes, move the tool at least 11 centimeters (4 inches) to each side of the roof center line, and 28 centimeters (11 inches) back from the windshield header.

(10) With the degaussing tool still energized, slowly back it away from the roof panel. When the tip of the tool is at least 61 centimeters (2 feet) from the roof panel, unplug the tool.

(11) Calibrate the compass and adjust the compass variance as described in this group.

REMOVAL AND INSTALLATION**OVERHEAD CONSOLE****LONG-TYPE**

- (1) Disconnect and isolate the battery negative cable.
- (2) Remove the single screw located forward of the display module that secures the overhead console to the upper windshield opening reinforcement (Fig. 3).



J938L-2

Fig. 3 Overhead Console Remove/Install - Long-Type

REMOVAL AND INSTALLATION (Continued)

- (3) To release the overhead console from the rear mounting bracket, slide the console forward until the rear of the console separates from the bracket.
- (4) Lower the overhead console far enough to access the two wire harness connectors.
- (5) Unplug one wire harness connector near the push button module towards the front of the overhead console.
- (6) Unplug one wire harness connector from the reading and courtesy lamp module near the rear of the overhead console.
- (7) Remove the overhead console from the vehicle.
- (8) Reverse the removal procedures to install. Tighten the overhead console mounting screw to 2.2 N-m (20 in. lbs.).

SHORT-TYPE

- (1) Disconnect and isolate the battery negative cable.
- (2) Remove the single screw located forward of the display module that secures the overhead console to the upper windshield opening reinforcement (Fig. 4).

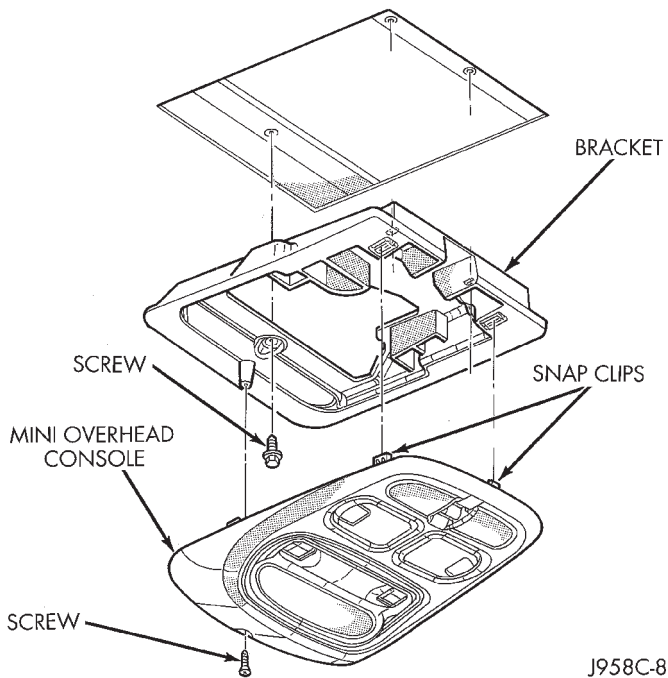


Fig. 4 Overhead Console Remove/Install - Short-Type

- (3) Using a trim stick or another suitable wide flat-bladed tool, gently pry downwards at the rear edge of the overhead console housing to release the two snap clip retainers that secure the console to the mounting bracket.
- (4) Lower the overhead console far enough to access the two wire harness connectors.
- (5) Unplug one wire harness connector from the trip computer, compass, and thermometer display module.

- (6) Unplug one wire harness connector from the power sunroof switch.
- (7) Remove the overhead console from the vehicle.
- (8) Reverse the removal procedures to install. Tighten the overhead console mounting screw to 2.2 N-m (20 in. lbs.).

TRIP COMPUTER, COMPASS, AND THERMOMETER DISPLAY MODULE

- (1) Remove the overhead console from the vehicle. See Overhead Console in this group for the procedures.
- (2) Remove the two screws that secure the forward end of the trip computer, compass, and thermometer display module to the overhead console housing (Fig. 5).

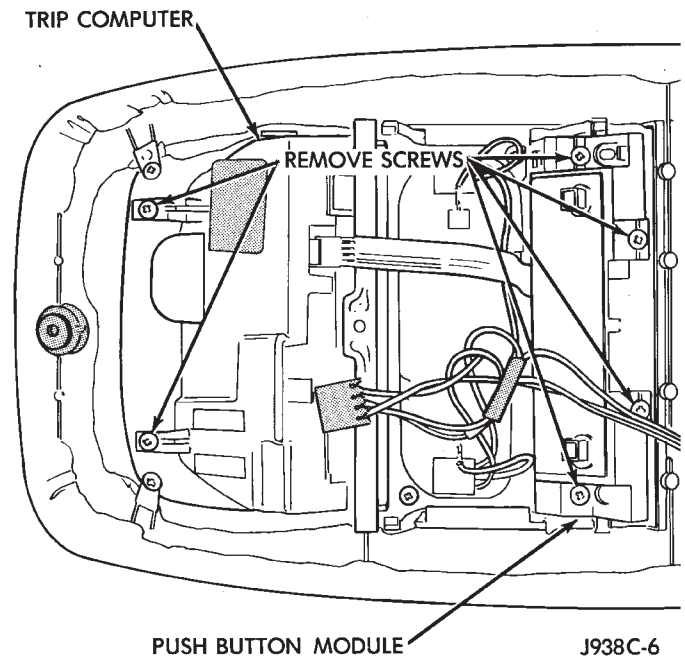


Fig. 5 Trip Computer, Compass, and Thermometer Display Module Remove/Install - Typical

- (3) Gently flex the sides of the overhead console housing as required to release the trip computer, compass, and thermometer display module mounting pins.
- (4) Pull the trip computer, compass, and thermometer display module away from the overhead console housing far enough to access the two wire harness connectors.
- (5) Unplug the overhead console and push button module wire harness connectors from the trip computer, compass, and thermometer display module.
- (6) Remove the trip computer, compass, and thermometer display module from the overhead console housing.

REMOVAL AND INSTALLATION (Continued)

(7) Reverse the removal procedures to install. Tighten the mounting screws to 2.2 N·m (20 in. lbs.).

PUSH BUTTON MODULE

(1) Remove the overhead console from the vehicle. See Overhead Console in this group for the procedures.

(2) Unplug the push button module wire harness connector from the trip computer, compass, and thermometer display module.

(3) Remove the four screws (long-type console) or two screws (short-type console) that secure the push button module to the overhead console housing.

(4) Remove the push button module from the overhead console.

(5) Reverse the removal procedures to install. Tighten the mounting screws to 2.2 N·m (20 in. lbs.).

READING AND COURTESY LAMP BULB

(1) Disconnect and isolate the battery negative cable.

(2) Insert a long, narrow, flat-bladed tool in the notch on the edge of the reading and courtesy lamp lens.

(3) Gently pry the lens downward from the overhead console housing and pivot the lens down. It may be necessary to move the tool along the edge of the lens to free the lens from the console housing.

(4) Unsnap the bulb from the bulb holders by pulling the bulb gently downwards.

(5) Install a new bulb by aligning its base with the bulb holders and pushing the bulb firmly into place.

(6) Pivot the lens back up into position and press upward firmly until it snaps into place.

(7) Connect the battery negative cable.

(8) Test the lamp by depressing the lens to check for proper lamp switching and lighting.

GARAGE DOOR OPENER STORAGE BIN DOOR

(1) Open the garage door opener storage bin door.

(2) Using a trim stick or another suitable wide flat-bladed tool, gently pry between the door pivot pin and the pivot hole on one side of the overhead console housing until the pivot pin clears the pivot hole.

(3) Use a gentle twisting action to remove the garage door opener storage bin door from the overhead console housing.

(4) To install, insert the pivot pin on one side of the door into the pivot hole in the overhead console housing. Gently depress the pivot pin tab on the other side of the door until it clears the side of the garage door opener storage bin opening and push the door into the opening. Guide the door into the opening so that the pivot pin snaps into the pivot hole.

SUNGLASSES STORAGE BIN

The sunglasses storage bin door and bin, housing, damper, spring and latch are serviced only as a unit. Remove the sunglasses storage bin module from the overhead console as follows:

(1) Remove the overhead console from the vehicle. See Overhead Console in this group for the procedures.

(2) Disengage the overhead console courtesy lamp wire harness from the retainers molded into the sunglasses storage bin housing.

(3) Remove the screws that secure the sunglasses storage bin module to the overhead console housing.

(4) Remove the sunglasses storage bin module from the overhead console.

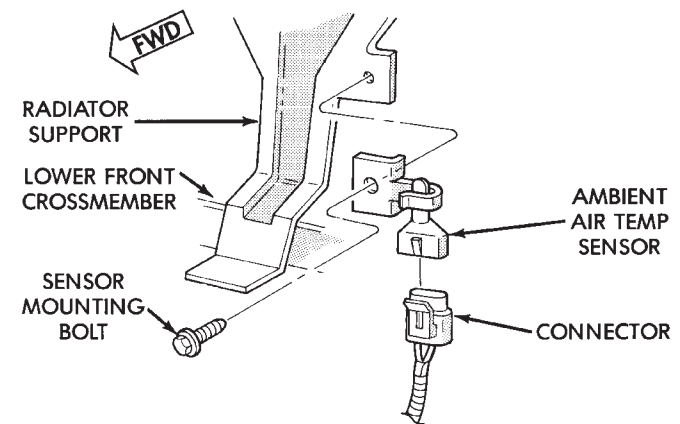
(5) Reverse the removal procedures to install. Tighten the mounting screws to 2.2 N·m (20 in. lbs.).

AMBIENT TEMPERATURE SENSOR

(1) Disconnect and isolate the battery negative cable.

(2) Remove the radiator grille from the vehicle. Refer to Group 23 - Body for the procedures.

(3) Locate the ambient temperature sensor, on the radiator support behind the grille (Fig. 6).



J938C-9

Fig. 6 Ambient Temperature Sensor Remove/Install

(4) Unplug the ambient temperature sensor wire harness connector.

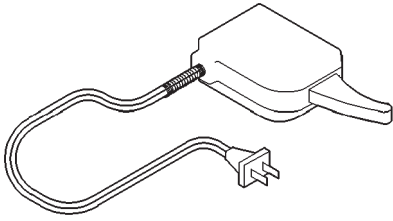
(5) Remove the screw that secures the ambient temperature sensor to the radiator support.

(6) Remove the ambient temperature sensor from the vehicle.

(7) Reverse the removal procedures to install. Tighten the ambient temperature sensor mounting screw to 2.2 N·m (20 in. lbs.).

SPECIAL TOOLS

COMPASS



Degaussing Tool 6029

WIRING DIAGRAMS

CONTENTS

	page		page
AIRBAG SYSTEM	8W-43-1	OVERHEAD CONSOLE	8W-49-1
AIR CONDITIONING/HEATER	8W-42-1	POWER DISTRIBUTION	8W-10-1
ANTI-LOCK BRAKES	8W-35-1	POWER DOOR LOCKS	8W-61-1
AUDIO SYSTEM	8W-47-1	POWER MIRRORS	8W-62-1
BODY CONTROL MODULE	8W-45-1	POWER SEAT	8W-63-1
CHARGING SYSTEM	8W-20-1	POWER SUNROOF	8W-64-1
COMPONENT INDEX	8W-02-1	POWER WINDOWS	8W-60-1
CONNECTOR LOCATIONS	8W-90-1	REAR LIGHTING	8W-51-1
CONNECTOR PIN-OUTS	8W-80-1	REAR WINDOW DEFOGGER	8W-48-1
FRONT LIGHTING	8W-50-1	SPLICE INFORMATION	8W-70-1
FUEL/IGNITION SYSTEMS	8W-30-1	SPLICE LOCATIONS	8W-95-1
GENERAL INFORMATION	8W-01-1	STARTING SYSTEM	8W-21-1
GROUND DISTRIBUTION	8W-15-1	TRAILER TOW	8W-54-1
HORN/CIGAR LIGHTER	8W-41-1	TRANSMISSION CONTROL SYSTEM	8W-31-1
INSTRUMENT CLUSTER	8W-40-1	TURN SIGNALS	8W-52-1
INTERIOR LIGHTING	8W-44-1	VEHICLE SPEED CONTROL	8W-33-1
JUNCTION BLOCK	8W-12-1	VEHICLE THEFT SECURITY SYSTEM	8W-39-1
MESSAGE CENTER	8W-46-1	WIPERS	8W-53-1

8W-01 GENERAL INFORMATION

INDEX

	page		page
DESCRIPTION AND OPERATION		TROUBLESHOOTING TESTS	9
CIRCUIT FUNCTIONS	4	TROUBLESHOOTING TOOLS	8
CIRCUIT INFORMATION	4	TROUBLESHOOTING WIRING PROBLEMS	10
CONNECTOR INFORMATION	7	SERVICE PROCEDURES	
ELECTROSTATIC DISCHARGE (ESD)		CONNECTOR AND TERMINAL REPLACEMENT .	12
SENSITIVE DEVICES	8	CONNECTOR REPLACEMENT	12
INTRODUCTION	1	DIODE REPLACEMENT	14
NOTES, CAUTIONS, and WARNINGS	7	TERMINAL REPLACEMENT	13
SECTION IDENTIFICATION	5	TERMINAL/CONNECTOR REPAIR-MOLEX	
SPLICE LOCATIONS	7	CONNECTORS	11
SYMBOLS	5	TERMINAL/CONNECTOR REPAIR—THOMAS	
TAKE OUTS	8	AND BETTS CONNECTORS	11
TERMINOLOGY	7	WIRING REPAIR	10
DIAGNOSIS AND TESTING		SPECIAL TOOLS	
INTERMITTENT AND POOR CONNECTIONS	9	WIRING/TERMINAL	15

DESCRIPTION AND OPERATION

INTRODUCTION

Chrysler wiring diagrams are designed to provide information regarding the vehicles wiring content. In order to effectively use Chrysler wiring diagrams to diagnose and repair a Chrysler vehicle, it is important to understand all of their features and characteristics.

Diagrams are arranged such that the power (B+) side of the circuit is placed near the top of the page, and the ground (B-) side of the circuit is placed near the bottom of the page.

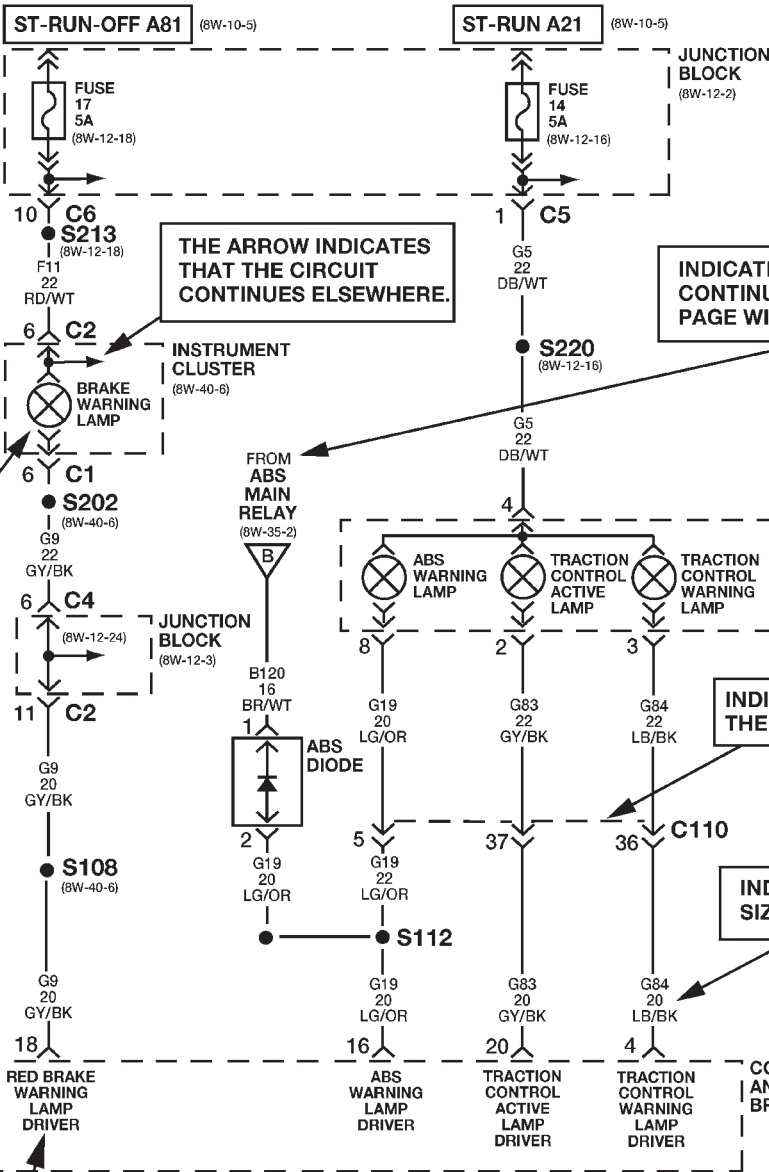
All switches, components, and modules are shown in the at rest position with the doors closed and the key removed from the ignition.

Components are shown two ways. A solid line around a component indicates that the component is complete. A dashed line around a component indicates that the component being shown is not complete. Incomplete components have a reference number to indicate the page where the component is shown complete.

It is important to realize that no attempt is made on the diagrams to represent components and wiring as they appear on the vehicle. For example, a short piece of wire is treated the same as a long one. In addition, switches and other components are shown as simply as possible, with regard to function only.

DESCRIPTION AND OPERATION (Continued)

DIAGRAMS ARE ARRANGED WITH THE POWER B+ SIDE OF THE CIRCUIT NEAR THE TOP OF THE PAGE, AND THE GROUND SIDE OF THE CIRCUIT NEAR THE BOTTOM OF THE PAGE.



THE ARROW INDICATES THAT THE CIRCUIT CONTINUES ELSEWHERE.

INDICATES CIRCUIT IS CONTINUED FROM ANOTHER PAGE WITHIN THE GROUP.

SYMBOLS USED ARE SIMILAR TO THOSE BEING USED WORLDWIDE.

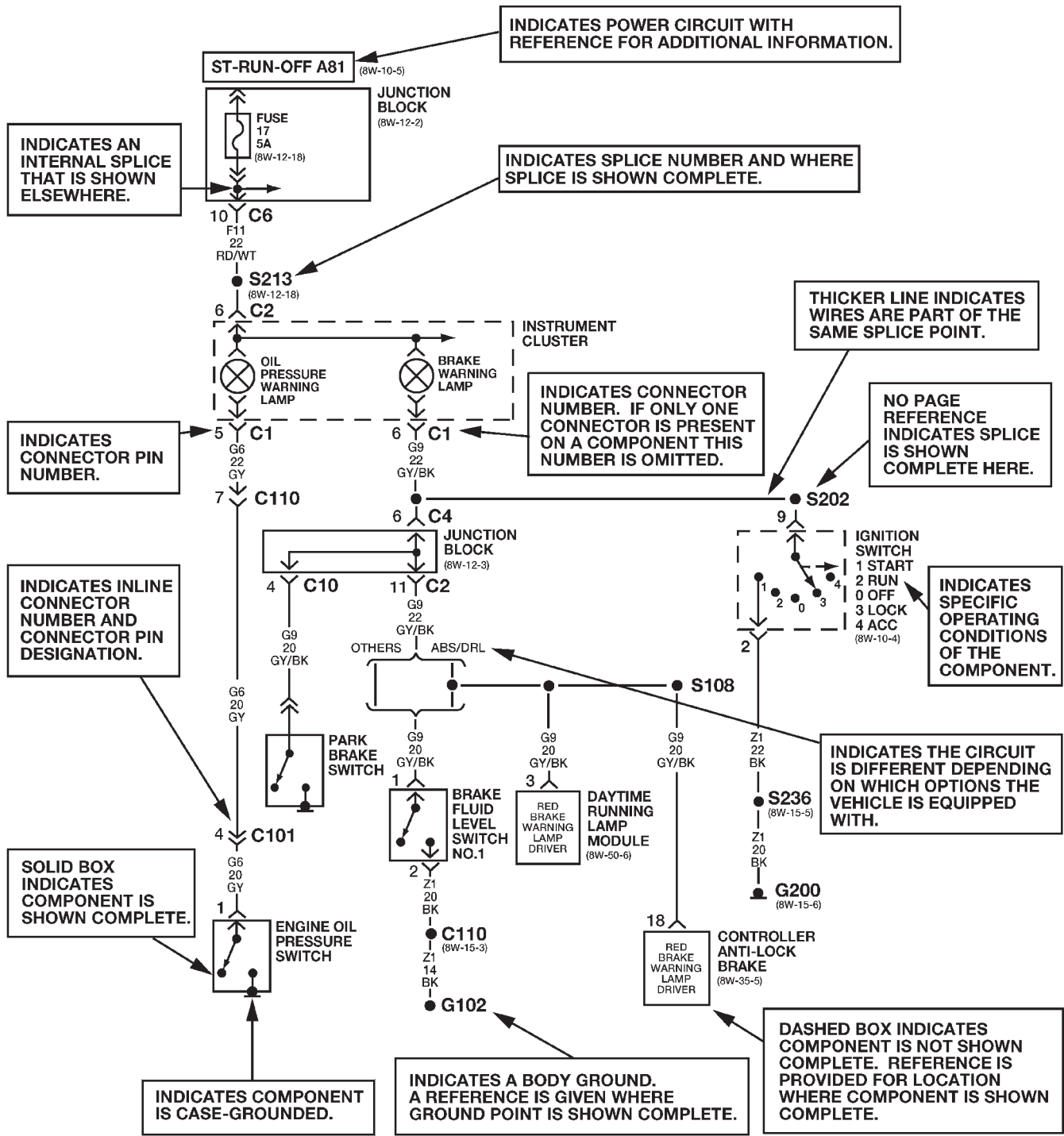
INDICATES WIRES ARE PART OF THE SAME CONNECTOR.

INDICATES CIRCUIT NUMBER, SIZE AND WIRE COLOR.

INTERNAL DESCRIPTIONS ARE GIVEN TO INDICATE THE FUNCTION OF THE CIRCUIT.

COMPONENT NAME IS ALSO USED AS THE REFERENCE FOR CONNECTOR PINOUTS.

DESCRIPTION AND OPERATION (Continued)



DESCRIPTION AND OPERATION (Continued)

CIRCUIT INFORMATION

Each wire shown in the diagrams contains a code which identifies the main circuit, part of the main circuit, gage of wire, and color (Fig. 1).

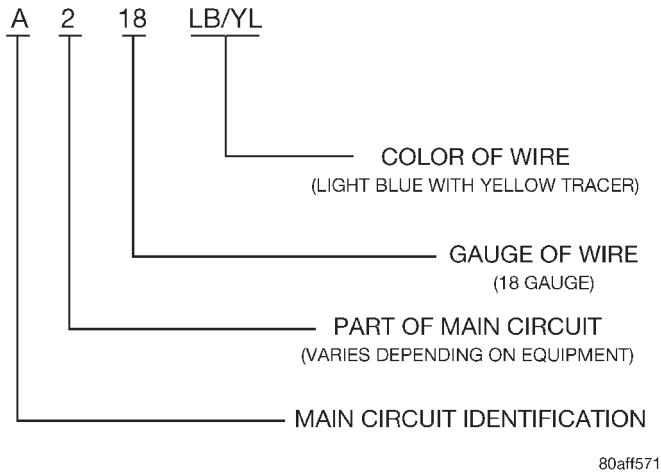


Fig. 1 Wire Code Identification

COLOR CODE	COLOR	STANDARD TRACER COLOR
BL	BLUE	WT
BK	BLACK	WT
BR	BROWN	WT
DB	DARK BLUE	WT
DG	DARK GREEN	WT
GY	GRAY	BK
LB	LIGHT BLUE	BK
LG	LIGHT GREEN	BK
OR	ORANGE	BK
PK	PINK	BK or WT
RD	RED	WT
TN	TAN	WT
VT	VIOLET	WT
WT	WHITE	BK
YL	YELLOW	BK
*	WITH TRACER	

CIRCUIT FUNCTIONS

All circuits in the diagrams use an alpha/numeric code to identify the wire and its function. To identify which circuit code applies to a system, refer to the Circuit Identification Code Chart. This chart shows the main circuits only and does not show the secondary codes that may apply to some models.

CIRCUIT	FUNCTION
A	BATTERY FEED
B	BRAKE CONTROLS
C	CLIMATE CONTROLS
D	DIAGNOSTIC CIRCUITS
E	DIMMING ILLUMINATION CIRCUITS
F	FUSED CIRCUITS
G	MONITORING CIRCUITS (GAUGES)
H	OPEN
I	NOT USED
J	OPEN
K	POWERTRAIN CONTROL MODULE
L	EXTERIOR LIGHTING
M	INTERIOR LIGHTING
N	NOT USED
O	NOT USED
P	POWER OPTION (BATTERY FEED)
Q	POWER OPTIONS (IGNITION FEED)
R	PASSIVE RESTRAINT
S	SUSPENSION/STEERING
T	TRANSMISSION/TRANSAXLE/ TRANSFER CASE
U	OPEN
V	SPEED CONTROL, WIPER/WASHER
W	OPEN
X	AUDIO SYSTEMS
Y	OPEN
Z	GROUND

DESCRIPTION AND OPERATION (Continued)

SECTION IDENTIFICATION



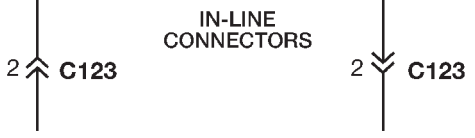



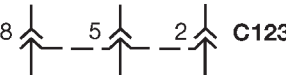













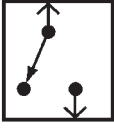
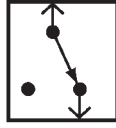




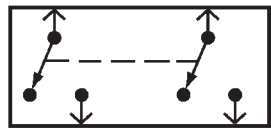




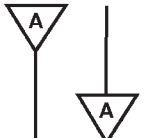
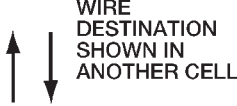





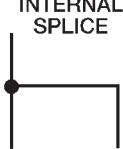
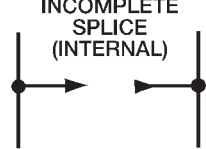

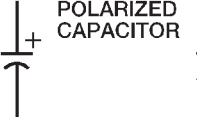




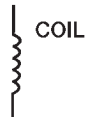


The wiring diagrams are grouped into individual sections. If a component is most likely found in a particular group, it will be shown complete (all wires, connectors, and pins) within that group. For example, the Auto Shutdown Relay is most likely to be found in Group 30, so it is shown there complete. It can, however, be shown partially in another group if it contains some associated wiring.

SYMBOLS

International symbols are used throughout the wiring diagrams. These symbols are consistent with those being used around the world

GROUP	TOPIC
8W-01 thru 8W-09	General Information and Diagram Overview
8W-10 thru 8W-19	Main Sources of Power and Vehicle Grounding
8W-20 thru 8W-29	Starting and Charging
8W-30 thru 8W-39	Powertrain/Drivetrain Systems
8W-40 thru 8W-49	Body Electrical items and A/C
8W-50 thru 8W-59	Exterior Lighting, Wipers, and Trailer Tow
8W-60 thru 8W-69	Power Accessories
8W-70	Splice Information
8W-80	Connector Pin Outs
8W-90	Connector Locations (including grounds)
8W-95	Splice Locations

DESCRIPTION AND OPERATION (Continued)

 BATTERY  GENERATOR STATOR COILS	 IN-LINE CONNECTORS 2 \uparrow C123 2 \downarrow C123
 FUSIBLE LINK  FUSE  CIRCUIT BREAKER	 MULTIPLE CONNECTOR 8 \uparrow - 5 \uparrow - 2 \uparrow C123  MALE CONNECTOR 4 \uparrow C1  FEMALE CONNECTOR 6 \downarrow C3
 BATT A0 HOT BAR  CHOICE BRACKET (8W-30-10) PAGE REFERENCE	 SINGLE FILAMENT LAMP  DUAL FILAMENT LAMP  ANTENNA
 CLOCKSPRING  GROUND G101  SCREW TERMINAL	 NPN TRANSISTOR  PNP TRANSISTOR  TONE GENERATOR
 OPEN SWITCH  CLOSED SWITCH	 LED  PHOTODIODE  DIODE  ZENER DIODE
 GANGED SWITCH  SLIDING DOOR CONTACT	 OXYGEN SENSOR  GAUGE  PIEZOELECTRIC CELL
 WIRE ORIGIN & DESTINATION SHOWN WITHIN CELL  WIRE DESTINATION SHOWN IN ANOTHER CELL	 RESISTOR  POTENTIOMETER  VARIABLE RESISTOR  HEATER ELEMENT
 EXTERNAL SPLICE S350  INTERNAL SPLICE  INCOMPLETE SPLICE (INTERNAL)	 NON-POLARIZED CAPACITOR  POLARIZED CAPACITOR  VARIABLE CAPACITOR
 ONE SPEED MOTOR  TWO SPEED MOTOR  REVERSIBLE MOTOR	 COIL  SOLENOID  SOLENOID VALVE

DESCRIPTION AND OPERATION (Continued)

TERMINOLOGY

This a list of terms with there definitions used in the wiring diagrams.

- Built-Up-Export Vehicles Built For Sale In Markets Other Than North America
- Except-Built-Up-Export Vehicles Built For Sale In North America
- LHD Left Hand Drive Vehicles
- RHD Right Hand Drive Vehicles
- ATX Automatic Transmission-Front Wheel Drive
- MTX Manual Transmission-Front Wheel Drive
- AT Automatic Transmission-Rear Wheel Drive
- MT Manual Transmission-Rear Wheel Drive
- SOHC Single Over Head Cam Engine
- DOHC Dual Over Head Cam Engine

CONNECTOR INFORMATION

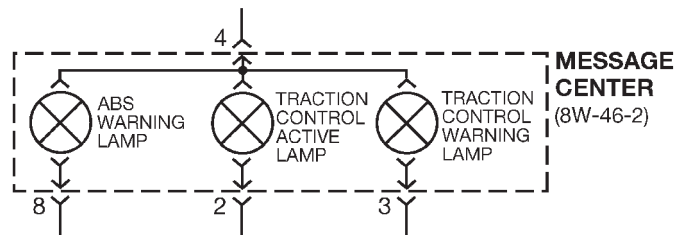
CAUTION: Not all connectors are serviced. Some connectors are serviced only with a harness. A typical example might be the Supplemental Restraint System connectors. Always check parts availability before attempting a repair.

IDENTIFICATION

In-line connectors are identified by a number, as follows:

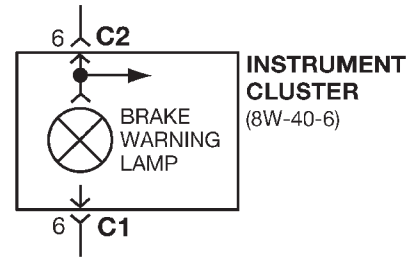
- In-line connectors located on the **engine compartment harness** are **C100** series numbers.
- Connectors located on the **instrument panel harness** are **C200** series numbers.
- Connectors located on the **body harness** are **C300** series numbers.
- **Jumper harness connectors** are **C400** series numbers.
- **Grounds and ground connectors** are identified with a “G” and follow the same series numbering as the in-line connector.

Component connectors are identified by the component name instead of a number (Fig. 2). Multiple connectors on a component use a C1, C2, etc. identifier (Fig. 3).



80aff5a3

Fig. 2 Component Identification



80aff5a4

Fig. 3 Connector Identification

LOCATIONS

Section 8W-90 contains connector/ground location illustrations. The illustrations contain the connector name (or number)/ground number and component identification. Connector/ground location charts in Section 8W-90 reference the illustration number for components and connectors.

Section 8W-80 shows each connector and the circuits involved with that connector. The connectors are identified using the name/number on the Diagram pages.

SPLICE LOCATIONS

Splice Location charts in Section 8W-70 show the entire splice, and provide references to other sections the splice serves.

Section 8W-95 contains illustrations that show the general location of the splices in each harness. The illustrations show the splice by number, and provide a written location.

NOTES, CAUTIONS, and WARNINGS

Throughout this group additional important information is presented in three ways; Notes, Cautions, and Warnings.

NOTES are used to help describe how switches or components operate to complete a particular circuit. They are also used to indicate different conditions that may appear on the vehicle. For example, an up-to and after condition.

CAUTIONS are used to indicate information that could prevent making an error that may damage the vehicle.

WARNINGS provide information to prevent personal injury and vehicle damage. Below is a list of general warnings that should be followed any time a vehicle is being serviced.

WARNING: ALWAYS WEAR SAFETY GLASSES FOR EYE PROTECTION.

WARNING: USE SAFETY STANDS ANYTIME A PROCEDURE REQUIRES BEING UNDER A VEHICLE.

DESCRIPTION AND OPERATION (Continued)

WARNING: BE SURE THAT THE IGNITION SWITCH ALWAYS IS IN THE OFF POSITION, UNLESS THE PROCEDURE REQUIRES IT TO BE ON.

WARNING: SET THE PARKING BRAKE WHEN WORKING ON ANY VEHICLE. AN AUTOMATIC TRANSMISSION SHOULD BE IN PARK. A MANUAL TRANSMISSION SHOULD BE IN NEUTRAL.

WARNING: OPERATE THE ENGINE ONLY IN A WELL-VENTILATED AREA.

WARNING: KEEP AWAY FROM MOVING PARTS WHEN THE ENGINE IS RUNNING, ESPECIALLY THE FAN AND BELTS.

WARNING: TO PREVENT SERIOUS BURNS, AVOID CONTACT WITH HOT PARTS SUCH AS THE RADIATOR, EXHAUST MANIFOLD(S), TAIL PIPE, CATALYTIC CONVERTER, AND MUFFLER.

WARNING: DO NOT ALLOW FLAME OR SPARKS NEAR THE BATTERY. GASES ARE ALWAYS PRESENT IN AND AROUND THE BATTERY.

WARNING: ALWAYS REMOVE RINGS, WATCHES, LOOSE HANGING JEWELRY, AND LOOSE CLOTHING.

TAKE OUTS

The abbreviation T/O is used in the component location section to indicate a point in which the wiring harness branches out to a component.

ELECTROSTATIC DISCHARGE (ESD) SENSITIVE DEVICES

All ESD sensitive components are solid state and a symbol (Fig. 4) is used to indicate this. When handling any component with this symbol comply with the following procedures to reduce the possibility of electrostatic charge build up on the body and inadvertent discharge into the component. If it is not known whether the part is ESD sensitive, assume that it is.

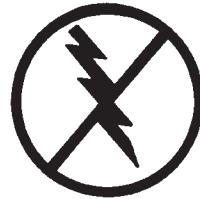
(1) Always touch a known good ground before handling the part. This should be repeated while handling the part and more frequently after sliding across a seat, sitting down from a standing position, or walking a distance.

(2) Avoid touching electrical terminals of the part, unless instructed to do so by a written procedure.

(3) When using a voltmeter, be sure to connect the ground lead first.

(4) Do not remove the part from its protective packing until it is time to install the part.

(5) Before removing the part from its package, ground the package to a known good ground on the vehicle.



948W-193

Fig. 4 Electrostatic Discharge Symbol

DIAGNOSIS AND TESTING

TROUBLESHOOTING TOOLS

When diagnosing a problem in an electrical circuit there are several common tools necessary. These tools are listed and explained below.

- Jumper Wire - This is a test wire used to connect two points of a circuit. It can be used to bypass an open in a circuit.

WARNING: NEVER USE A JUMPER WIRE ACROSS A LOAD, SUCH AS A MOTOR, CONNECTED BETWEEN A BATTERY FEED AND GROUND.

- Voltmeter - Used to check for voltage on a circuit. Always connect the black lead to a known good ground and the red lead to the positive side of the circuit.

CAUTION: Most of the electrical components used in today's vehicle are solid state. When checking voltages in these circuits use a meter with a 10-megohm or greater impedance rating.

- Ohmmeter - Used to check the resistance between two points of a circuit. Low or no resistance in a circuit means good continuity.

CAUTION: - Most of the electrical components used in today's vehicle are Solid State. When checking resistance in these circuits use a meter with a 10-megohm or greater impedance rating. In addition, make sure the power is disconnected from the circuit. Circuits that are powered up by the vehicle electrical system can cause damage to the equipment and provide false readings.

DIAGNOSIS AND TESTING (Continued)

• Probing Tools - These tools are used for probing terminals in connectors (Fig. 5). Select the proper size tool from Special Tool Package 6807, and insert it into the terminal being tested. Use the other end of the tool to insert the meter probe.

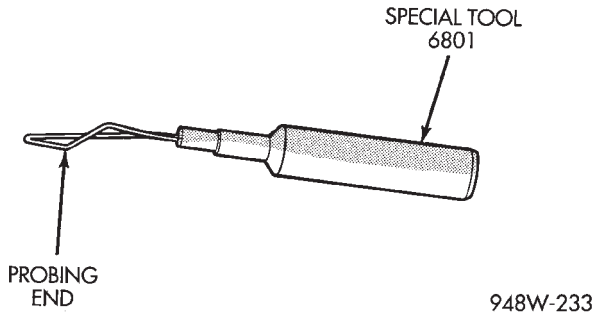


Fig. 5 Probing Tool

INTERMITTENT AND POOR CONNECTIONS

Most intermittent electrical problems are caused by faulty electrical connections or wiring. It is also possible for a sticking component or relay to cause a problem. Before condemning a component or wiring assembly check the following items.

- Connectors are fully seated
- Spread terminals, or terminal push out
- Terminals in the wiring assembly are fully seated into the connector/component and locked in position
- Dirt or corrosion on the terminals. Any amount of corrosion or dirt could cause an intermittent problem
- Damaged connector/component casing exposing the item to dirt and moisture
- Wire insulation that has rubbed through causing a short to ground
- Some or all of the wiring strands broken inside of the insulation covering.
- Wiring broken inside of the insulation

TROUBLESHOOTING TESTS

Before beginning any tests on a vehicles electrical system use the Wiring Diagrams and study the circuit. Also refer to the Troubleshooting Wiring Problems in this section.

TESTING FOR VOLTAGE POTENTIAL

- (1) Connect the ground lead of a voltmeter to a known good ground (Fig. 6).
- (2) Connect the other lead of the voltmeter to the selected test point. The vehicle ignition may need to be turned ON to check voltage. Refer to the appropriate test procedure.

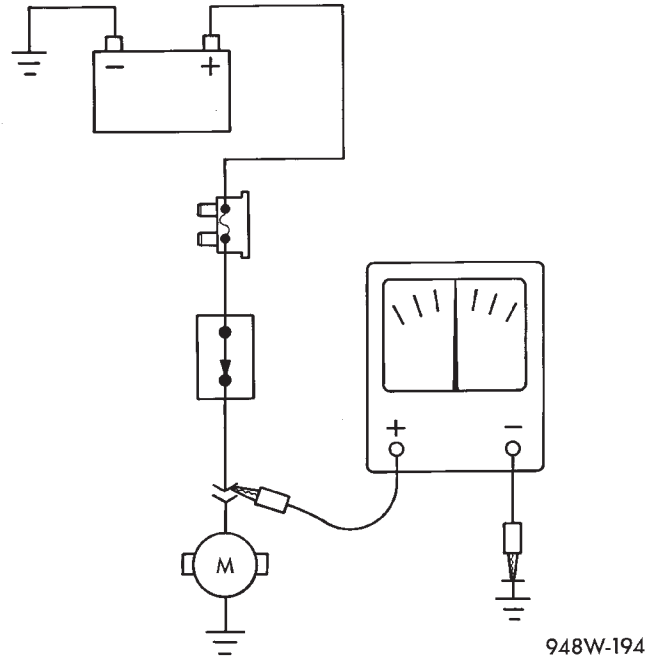


Fig. 6 Testing for Voltage Potential

TESTING FOR CONTINUITY

- (1) Remove the fuse for the circuit being checked or, disconnect the battery.
- (2) Connect one lead of the ohmmeter to one side of the circuit being tested (Fig. 7).
- (3) Connect the other lead to the other end of the circuit being tested. Low or no resistance means good continuity.

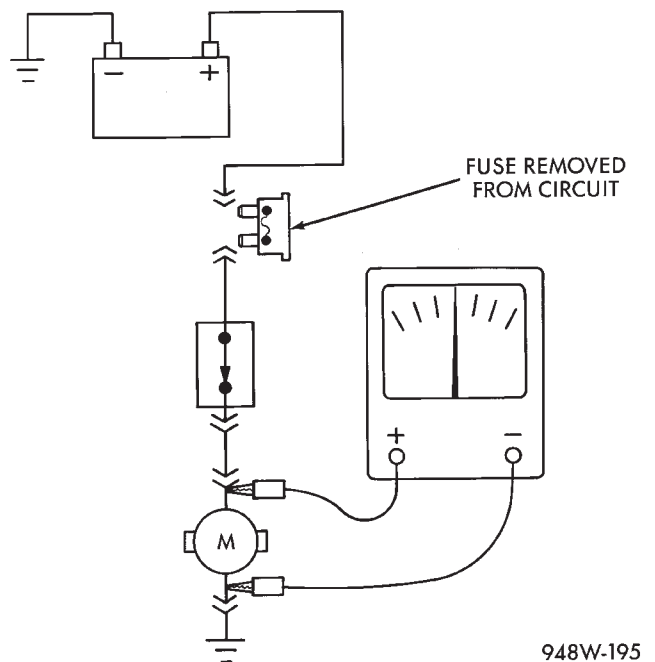


Fig. 7 Testing for Continuity

DIAGNOSIS AND TESTING (Continued)

TESTING FOR A SHORT TO GROUND

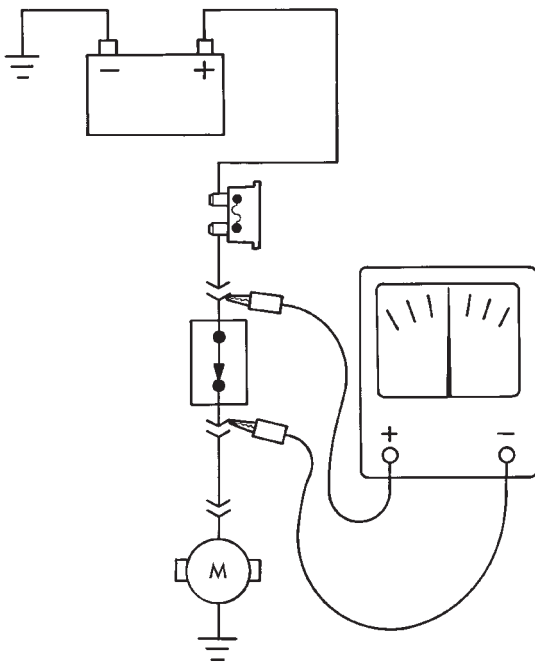
- (1) Remove the fuse and disconnect all items involved with the fuse.
- (2) Connect a test light or a voltmeter across the terminals of the fuse.
- (3) Starting at the fuse block, wiggle the wiring harness about six to eight inches apart and watch the voltmeter/test lamp.
- (4) If the voltmeter registers voltage or the test lamp glows, there is a short to ground in that general area of the wiring harness.

TESTING FOR A SHORT TO GROUND ON FUSES POWERING SEVERAL LOADS

- (1) Refer to the wiring diagrams and disconnect or isolate all items on the suspected fused circuits.
- (2) Replace the blown fuse.
- (3) Supply power to the fuse by turning ON the ignition switch or re-connecting the battery.
- (4) Start connecting the items in the fuse circuit one at a time. When the fuse blows the circuit with the short to ground has been isolated.

TESTING FOR A VOLTAGE DROP

- (1) Connect the positive lead of the voltmeter to the side of the circuit closest to the battery (Fig. 8).
- (2) Connect the other lead of the voltmeter to the other side of the switch or component.
- (3) Operate the item.
- (4) The voltmeter will show the difference in voltage between the two points.



948W-196

Fig. 8 Testing for Voltage Drop

TROUBLESHOOTING WIRING PROBLEMS

When troubleshooting wiring problems there are six steps which can aid in the procedure. The steps are listed and explained below. Always check for non-factory items added to the vehicle before doing any diagnosis. If the vehicle is equipped with these items, disconnect them to verify these add-on items are not the cause of the problem.

- (1) Verify the problem.
- (2) Verify any related symptoms. Do this by performing operational checks on components that are in the same circuit. Refer to the wiring diagrams.
- (3) Analyze the symptoms. Use the wiring diagrams to determine what the circuit is doing, where the problem most likely is occurring and where the diagnosis will continue.
- (4) Isolate the problem area.
- (5) Repair the problem.
- (6) Verify proper operation. For this step check for proper operation of all items on the repaired circuit. Refer to the wiring diagrams.

SERVICE PROCEDURES

WIRING REPAIR

When replacing or repairing a wire, it is important that the correct gage be used as shown in the wiring diagrams. The wires must also be held securely in place to prevent damage to the insulation.

- (1) Disconnect battery negative cable.
- (2) Remove 1 inch of insulation from each end of the wire.
- (3) Place a piece of heat shrink tubing over one side of the wire. Make sure the tubing will be long enough to cover and seal the entire repair area.
- (4) Spread the strands of the wire apart on each part of the exposed wire (example 1) (Fig. 9).
- (5) Push the two ends of wire together until the strands of wire are close to the insulation (example 2) (Fig. 9).
- (6) Twist the wires together (example 3) (Fig. 9).
- (7) Solder the connection together using rosin core type solder only. **Do not use acid core solder.**
- (8) Center the heat shrink tubing over the joint, and heat using a heat gun. Heat the joint until the tubing is tightly sealed and sealant comes out of both ends of the tubing.
- (9) Secure the wire to the existing ones to prevent chafing or damage to the insulation.
- (10) Connect battery and test all affected systems.

SERVICE PROCEDURES (Continued)

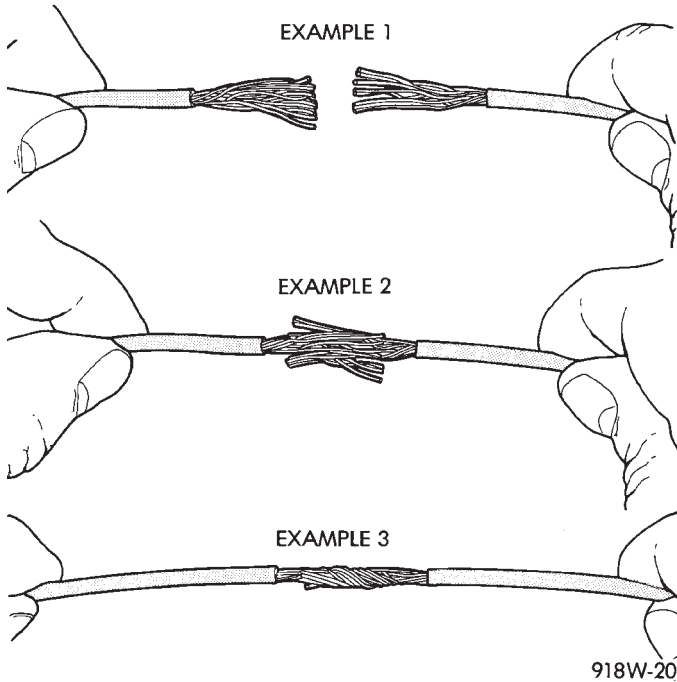


Fig. 9 Wire Repair

918W-20

TERMINAL/CONNECTOR REPAIR-MOLEX CONNECTORS

- (1) Disconnect battery.
- (2) Disconnect the connector from its mating half/component.
- (3) Insert the terminal releasing special tool 6742 into the terminal end of the connector (Fig. 10).

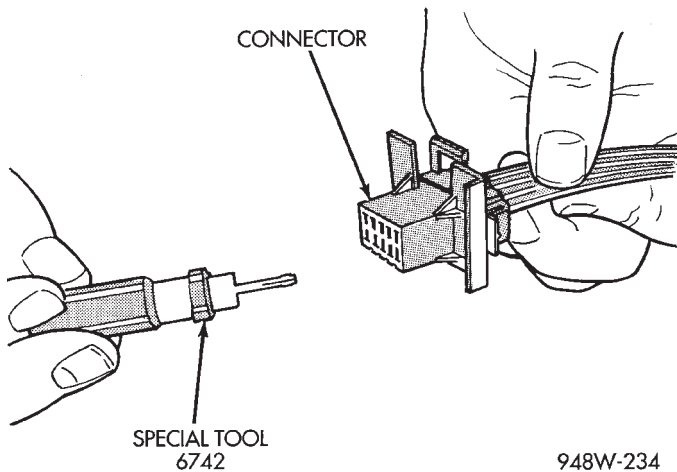


Fig. 10 Molex Connector Repair

948W-234

- (4) Using special tool 6742 release the locking fingers on the terminal (Fig. 11).
- (5) Pull on the wire to remove it from the connector.
- (6) Repair or replace the connector or terminal, as necessary.

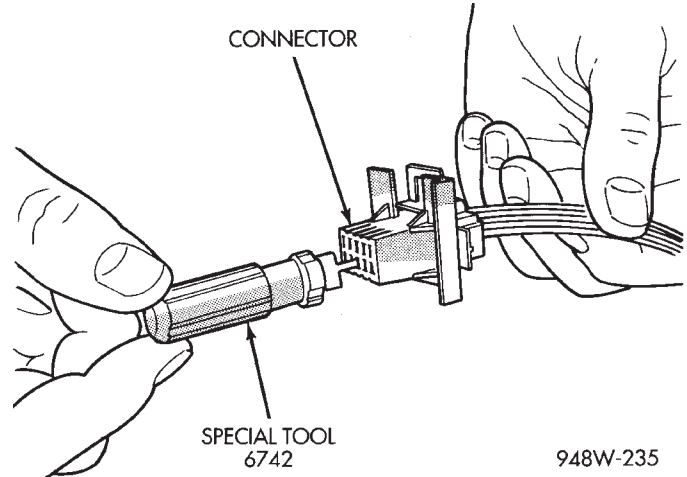
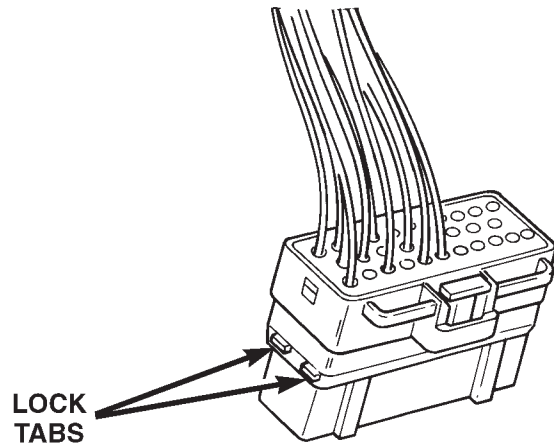


Fig. 11 Using Special Tool 6742

948W-235

TERMINAL/CONNECTOR REPAIR—THOMAS AND BETTS CONNECTORS

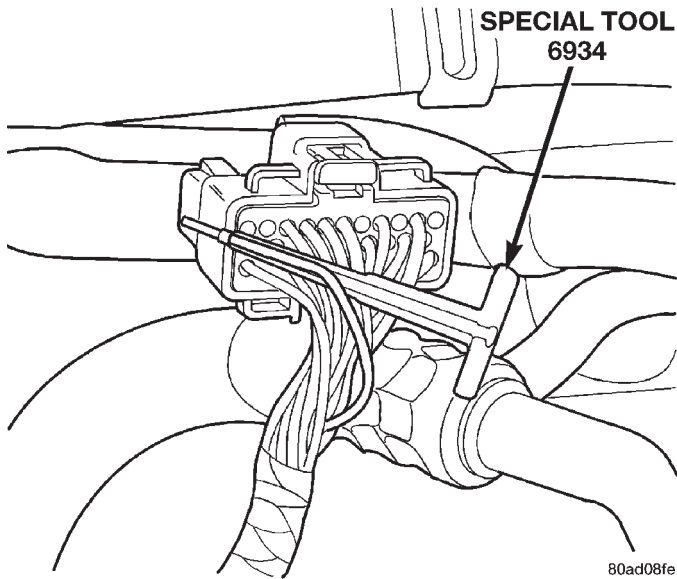
- (1) Disconnect battery.
- (2) Disconnect the connector from its mating half/component.
- (3) Push in the two lock tabs on the side of the connector (Fig. 12).



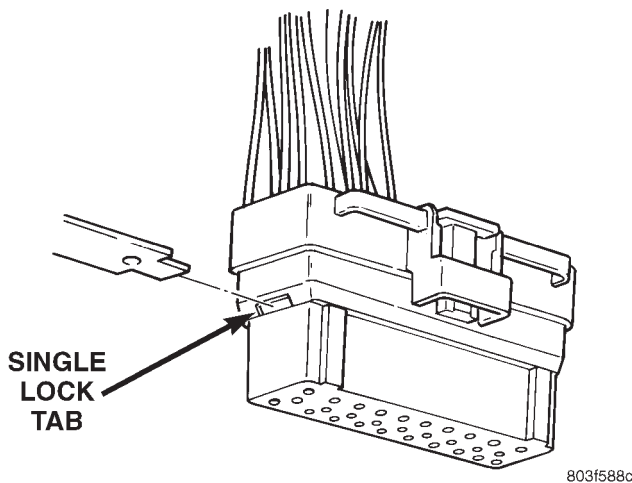
803f588a

Fig. 12 Thomas and Betts Connector Lock Release Tabs

- (4) Insert the probe end of special tool 6934 into the back of the connector cavity (Fig. 13).
- (5) Grasp the wire and tool 6934 and slowly remove the wire and terminal from the connector.
- (6) Repair or replace the terminal.
- (7) Install the wire and terminal in the connector. Fully seat the terminal in the connector.
- (8) Push in the single lock tab on the side of the connector (Fig. 14).

SERVICE PROCEDURES (Continued)**Fig. 13 Removing Wire Terminal**

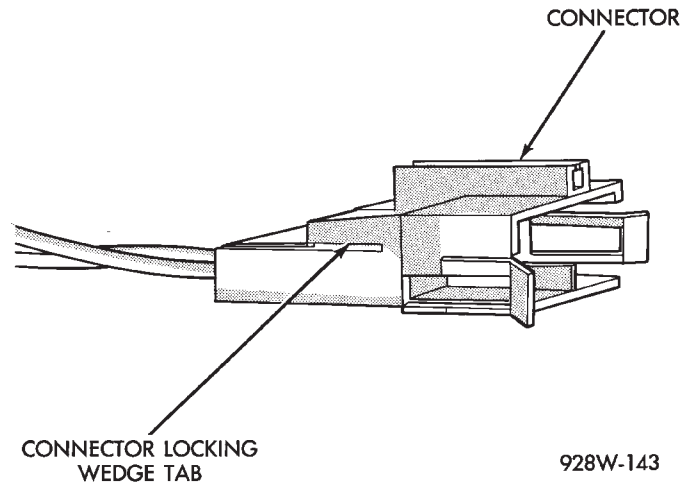
80ad08fe

**Fig. 14 Single Lock Tab**

803f588c

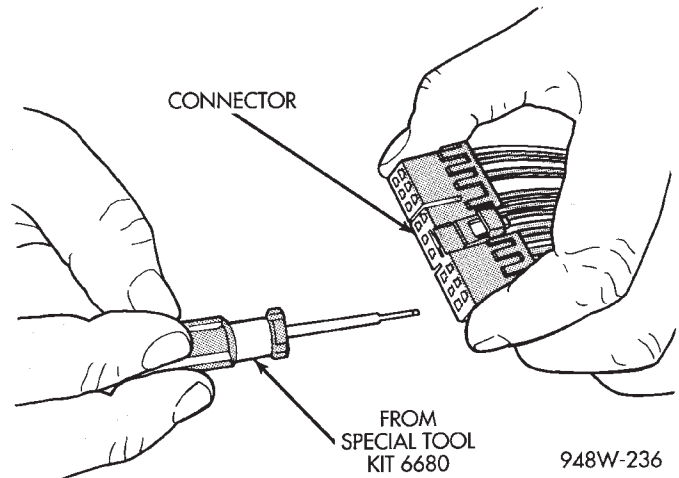
CONNECTOR REPLACEMENT

- (1) Disconnect battery.
- (2) Disconnect the connector that is to be repaired from its mating half/component.
- (3) Remove the connector locking wedge, if required (Fig. 15).
- (4) Position the connector locking finger away from the terminal using the proper pick from special tool kit 6680. Pull on the wire to remove the terminal from the connector (Fig. 16) (Fig. 17).
- (5) Reset the terminal locking tang, if it has one.
- (6) Insert the removed wire in the same cavity on the repair connector.
- (7) Repeat steps four through six for each wire in the connector, being sure that all wires are inserted into the proper cavities. For additional connector pin-out identification, refer to the wiring diagrams.

**Fig. 15 Connector Locking Wedge**

928W-143

- (8) Insert the connector locking wedge into the repaired connector, if required.
- (9) Connect connector to its mating half/component.
- (10) Connect battery and test all affected systems.

**Fig. 16 Terminal Removal**

948W-236

CONNECTOR AND TERMINAL REPLACEMENT

- (1) Disconnect battery.
- (2) Disconnect the connector (that is to be repaired) from its mating half/component.
- (3) Cut off the existing wire connector directly behind the insulator. Remove six inches of tape from the harness.
- (4) Stagger cut all wires on the harness side at 1/2 inch intervals (Fig. 18).
- (5) Remove 1 inch of insulation from each wire on the harness side.
- (6) Stagger cut the matching wires on the repair connector assembly in the opposite order as was done on the harness side of the repair. Allow extra length for soldered connections. Check that the overall length is the same as the original (Fig. 18).

SERVICE PROCEDURES (Continued)

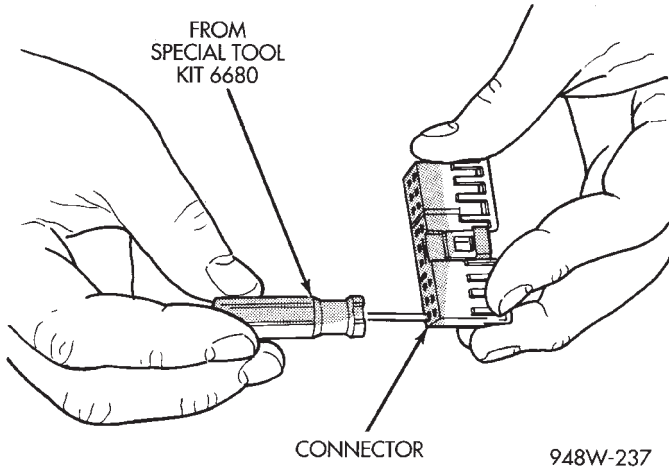


Fig. 17 Terminal Removal Using Special Tool

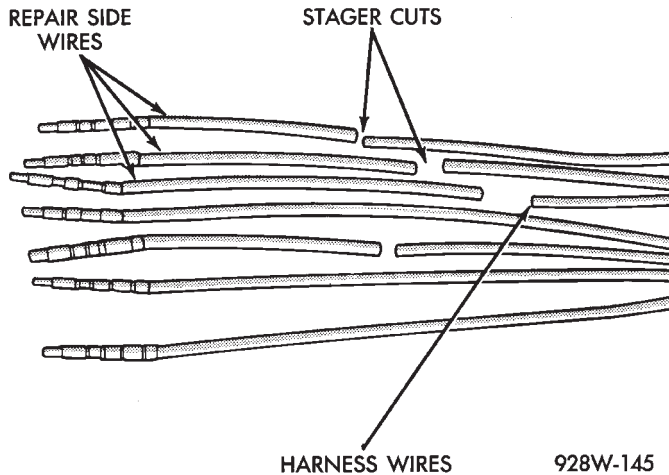


Fig. 18 Stager Cutting Wires

- (7) Remove 1 inch of insulation from each wire.
- (8) Place a piece of heat shrink tubing over one side of the wire. Be sure the tubing will be long enough to cover and seal the entire repair area.
- (9) Spread the strands of the wire apart on each part of the exposed wires.
- (10) Push the two ends of wire together until the strands of wire are close to the insulation.
- (11) Twist the wires together.
- (12) Solder the connection together using rosin core type solder only. **Do not use acid core solder.**
- (13) Center the heat shrink tubing over the joint and heat using a heat gun. Heat the joint until the tubing is tightly sealed and sealant comes out of both ends of the tubing.
- (14) Repeat steps 8 through 13 for each wire.
- (15) Re-tape the wire harness starting 1-1/2 inches behind the connector and 2 inches past the repair.
- (16) Re-connect the repaired connector.
- (17) Connect the battery, and test all affected systems.

TERMINAL REPLACEMENT

- (1) Disconnect battery.
- (2) Disconnect the connector being repaired from its mating half. Remove connector locking wedge, if required (Fig. 19).
- (3) Remove connector locking wedge, if required (Fig. 19).

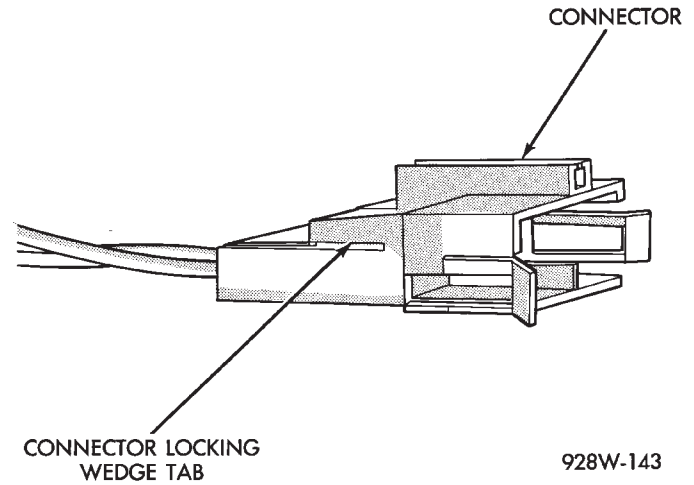


Fig. 19 Connector Locking Wedge Tab (Typical)

- (4) Position the connector locking finger away from the terminal using the proper pick from special tool kit 6680. Pull on the wire to remove the terminal from the connector (Fig. 20) (Fig. 21).

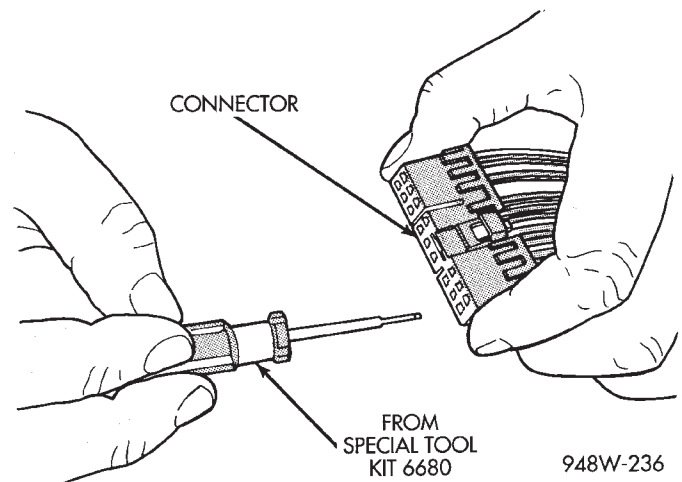


Fig. 20 Terminal Removal

- (5) Cut the wire 6 inches from the back of the connector.
- (6) Remove 1 inch of insulation from the wire on the harness side.
- (7) Select a wire from the terminal repair assembly that best matches the color wire being repaired.
- (8) Cut the repair wire to the proper length and remove 1 inch of insulation.

SERVICE PROCEDURES (Continued)

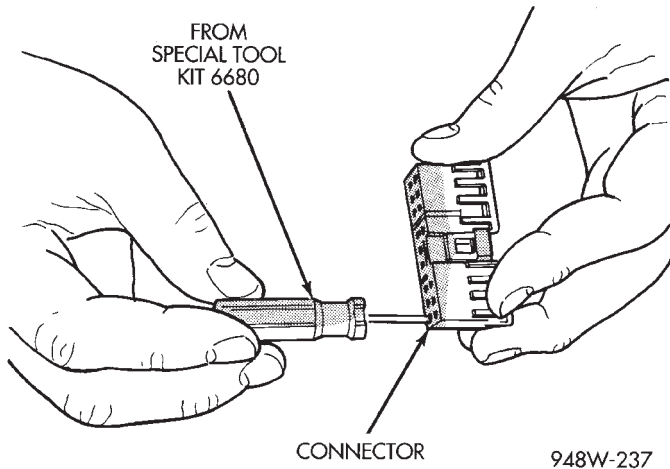


Fig. 21 Terminal Removal Using Special Tool

(9) Place a piece of heat shrink tubing over one side of the wire. Make sure the tubing will be long enough to cover and seal the entire repair area.

(10) Spread the strands of the wire apart on each part of the exposed wires.

(11) Push the two ends of wire together until the strands of wire are close to the insulation.

(12) Twist the wires together.

(13) Solder the connection together using rosin core type solder only. **Do not use acid core solder.**

(14) Center the heat shrink tubing over the joint and heat using a heat gun. Heat the joint until the tubing is tightly sealed and sealant comes out of both ends of the tubing.

(15) Insert the repaired wire into the connector.

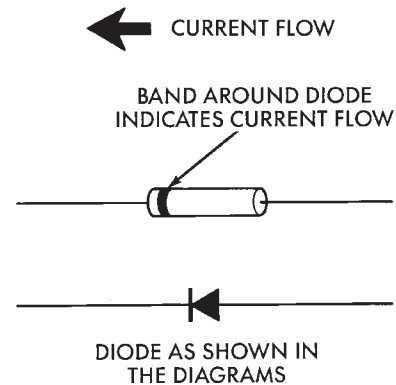
(16) Install the connector locking wedge, if required, and reconnect the connector to its mating half/component.

(17) Re-tape the wire harness starting 1-1/2 inches behind the connector and 2 inches past the repair.

(18) Connect battery, and test all affected systems.

DIODE REPLACEMENT

- (1) Disconnect the battery.
- (2) Locate the diode in the harness, and remove the protective covering.
- (3) Remove the diode from the harness, pay attention to the current flow direction (Fig. 22).



948W-197

Fig. 22 Diode Identification

(4) Remove the insulation from the wires in the harness. Only remove enough insulation to solder in the new diode.

(5) Install the new diode in the harness, making sure current flow is correct. If necessary refer to the appropriate wiring diagram for current flow.

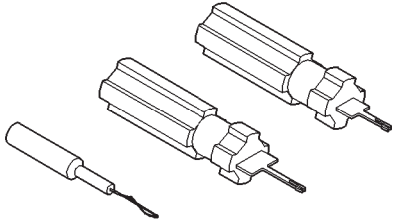
(6) Solder the connection together using rosin core type solder only. **Do not use acid core solder.**

(7) Tape the diode to the harness using electrical tape making, sure the diode is completely sealed from the elements.

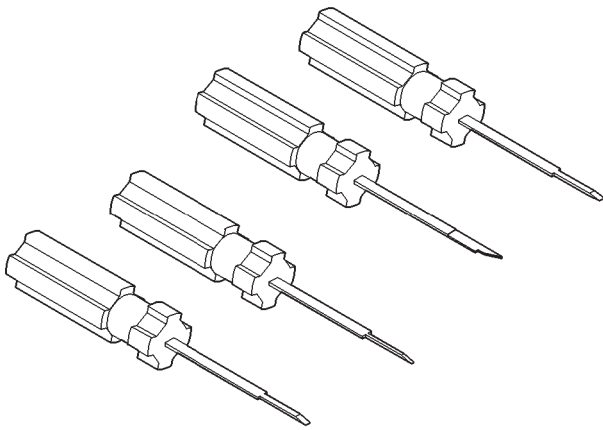
(8) Re-connect the battery, and test affected systems.

SPECIAL TOOLS

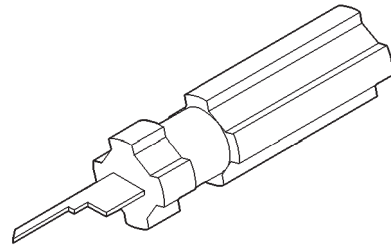
WIRING/TERMINAL



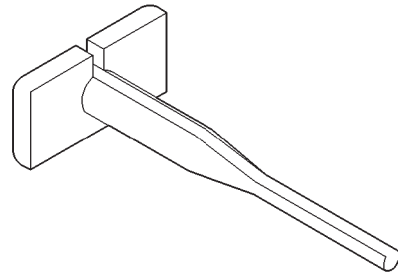
Probing Tool Package 6807



Terminal Pick 6680



Terminal Removing Tool 6932



Terminal Removing Tool 6934

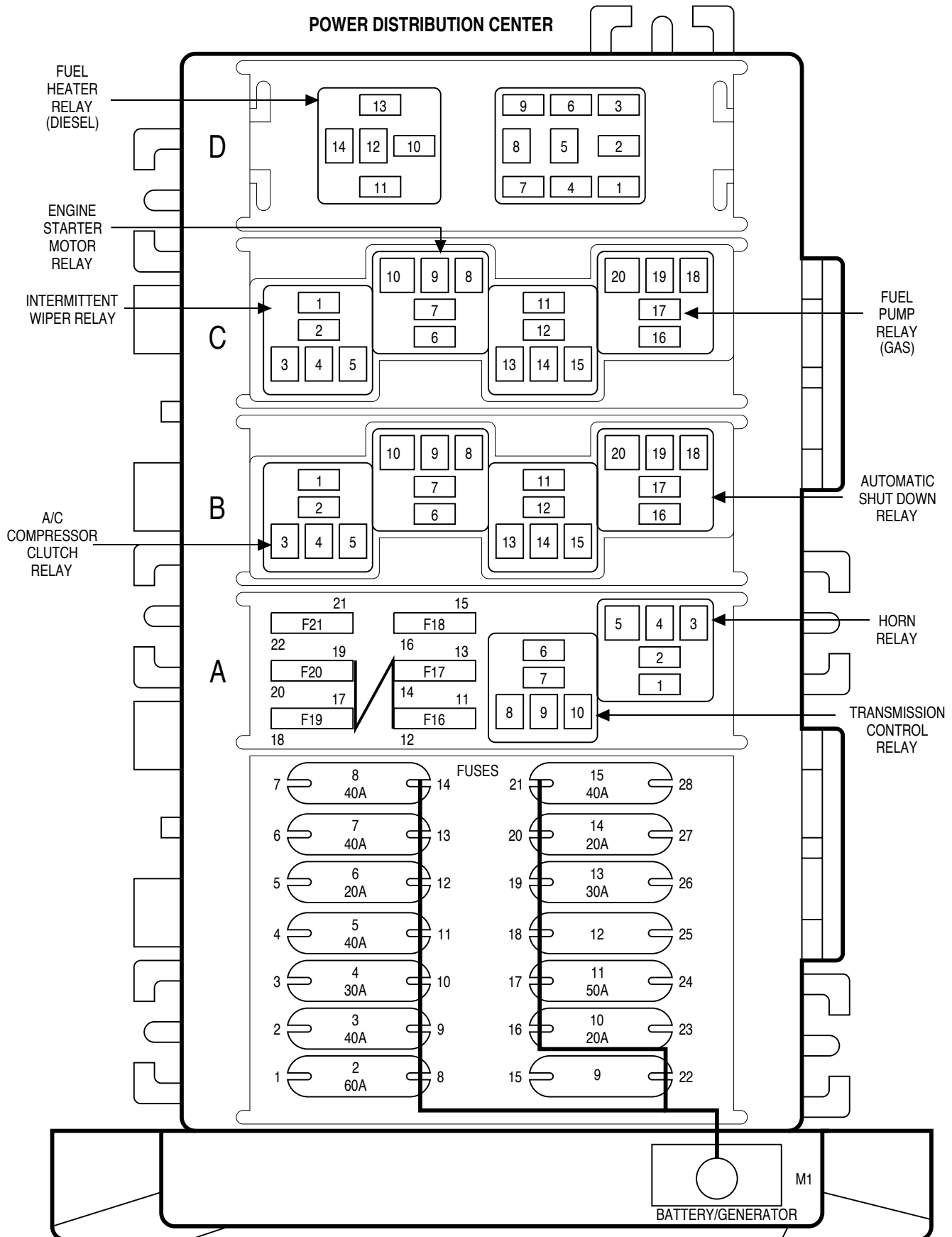
8W-02 COMPONENT INDEX

Component	Page	Component	Page
A/C Compressor Clutch8W-42	Driver Seat Heater Control Module8W-63
A/C Compressor Clutch Relay8W-42	Duty Cycle Evap/Purge Solenoid8W-30
A/C Heater Control8W-42	Electronic Flasher8W-52
A/C Pressure Switches8W-42	Electronic Vacuum Modulator8W-30
Airbag Control Module8W-43	Engine Coolant Temperature Sensor8W-30
Airbags8W-43	Engine Starter Motor8W-21
Ambient Temperature Sensor8W-42, 45	Engine Starter Motor Relay8W-21
Antenna8W-47	Floor Console Lamps8W-44
Ash Receiver Lamp8W-44	Fog Lamp Relay8W-50
Automatic Day/Night Mirror8W-44	Fog Lamp Switch8W-50
Automatic Headlamp Light Sensor/ VTSS LED8W-45	Fog Lamps8W-50, 51
Automatic Headlamp Relay8W-50	Four Wheel Drive Switch8W-46
Automatic Shut Down Relay8W-30	Fuel Heater8W-30
Automatic Temperature Control Module8W-42	Fuel Heater Relay8W-30
Back-Up Lamp Switch8W-44, 51	Fuel Injectors8W-30
Back-Up Lamps8W-51	Fuel Pump Module8W-30
Battery8W-20	Fuel Pump Relay8W-30
Battery Temperature Sensor8W-30	Fuel Sender Unit8W-30
Blend Door Actuator8W-42	Fuses (JB)8W-12
Blower Motor8W-42	Fuses (PDC)8W-10
Blower Motor Resistor Block8W-42	Fusible Link8W-10, 20
Blower Power Module8W-42	G Switch8W-35
Body Control Module8W-45	Gauges8W-40
Brake Pressure Switch8W-40	Generator8W-20
Brake Warning Lamp8W-40	Glove Box Lamp8W-44
Camshaft Position Sensor8W-30	Glow Plug8W-30
Cargo Lamp8W-44	Glow Plug Relay8W-30
Center High Mounted Stop Lamps8W-51	Grounds8W-15
Check Lamps8W-40	Headlamp Dimmer Switch8W-50
Cigar Lighter8W-41	Headlamp Leveling Motors8W-50
Cigar Lighter Lamp8W-44	Headlamp Leveling Switch8W-50
Cigar Lighter Relay8W-41	Headlamp Switch8W-50
Cigar Lighter/Power Outlet8W-41	Headlamps8W-50
Circuit Breakers8W-12	Heated Seat Backs8W-63
Clockspring No. 18W-33, 41, 47	Heated Seat Cushions8W-63
Clockspring No. 28W-43	Heated Seat Switch8W-63
Clutch Interlock Switch8W-10, 21, 21-2	High Pressure Cut-Out Switch8W-30
Clutch Interlock Switch Jumper8W-10, 21	High Speed Cooling Fan Relay8W-30
Controller Anti-Lock Brake8W-35	Hood Switch8W-39
Coolant Level Sensor8W-30, 46	Horn Relay8W-39, 41
Cooling Fan Motor8W-30	Horn Switch8W-39, 41
Courtesy Lamp Relay8W-44	Horns8W-39, 41
Courtesy Lamps8W-44	Idle Air Control Motor8W-30
Crankshaft Position Sensor8W-30	Ignition Coil8W-30
Cruise Switches8W-30, 33	Ignition Relay8W-30
Cylinder Lock Switches8W-39	Ignition Switch8W-10
Data Link Connector8W-30	Illumination Lamps8W-40
Daytime Running Lamp Module8W-50	In-Car Temperature Sensor8W-42
Diagnostic Connector8W-30	Indicator Lamps8W-40
Dome/Reading Lamp8W-44	Instrument Cluster8W-40
Door Ajar Switches8W-39, 44, 45	Intake Air Temperature Sensor8W-30
Door Lock Motors8W-61	Intermittent Wiper Relay8W-53
Door Modules8W-60, 61, 62, 63	Intermittent Wiper Switch8W-53
		Junction Block8W-12

Component	Page	Component	Page
Key-In Switch/Halo Lamp	8W-44	Rear Window Defogger	8W-48
Lamp Outage Module	8W-51	Rear Window Defogger Relay	8W-48
Leak Detection Pump	8W-30	Rear Window Defogger Switch	8W-48
License Lamps	8W-51	Rear Wiper Module	8W-53
Liftgate Ajar Switch	8W-39, 44, 45, 53	Rear Wiper Motor Control	8W-53
Liftgate Cylinder Lock Switch	8W-39	Rear Wiper/Washer Switch	8W-53
Liftgate Lock Motor	8W-61	Recirculation Door Actuator	8W-42
Liftglass Ajar Switch	8W-39, 44, 45, 53	Remote Radio Switches	8W-47
Liftglass Limit Switch	8W-61	Seat Belt Switch	8W-45
Liftglass Push Button	8W-61	Shift Interlock	8W-31, 33
Liftglass Release Solenoid	8W-61	Side Marker Lamps	8W-51
Low Speed Cooling Fan Relay	8W-30	Side Repeaters	8W-50, 52
Lower Hose Coolant Switch	8W-30	Sliding Roof Motor	8W-64
Lumbar Motors	8W-63	Sliding Roof Position Switch	8W-64
Lumbar Sensor/Motors	8W-63	Solar Sensor	8W-42
Lumbar Switches	8W-63	Speakers	8W-47
Manifold Absolute Pressure Sensor	8W-30	Speedometer	8W-40
Marker Lamps	8W-50, 52	Splice Information	8W-70
Mass Air Flow Module	8W-30	Stop Lamp Switch	8W-33
Memory Seat Module	8W-63	Sunroof Control Module	8W-64
Memory Set Switch	8W-63	Sunroof Switch	8W-64
Mercury Switch	8W-44	Switch Pod	8W-44
Mode Door Actuator	8W-42	Tachometer	8W-40
MSA Controller	8W-30	Tail/Stop Lamps	8W-51
Needle Sensor	8W-30	Throttle Position Sensor	8W-30, 31
Oil Pressure Gauge	8W-40	Torque Converter Clutch Solenoid Control	8W-31
Oil Pressure Sensor	8W-30	Trailer Brake Provision	8W-54
Output Shaft Speed Sensor	8W-30, 31	Trailer Tow Circuit Breaker	8W-54
Outside Power Mirrors	8W-62	Trailer Tow Connectors	8W-54
Overdrive Pressure Switch	8W-31	Trailer Tow Relays	8W-54
Overdrive Solenoid Control	8W-31	Transmission Control Relay	8W-31
Overhead Console	8W-49	Transmission Solenoid Assembly	8W-31
Oxygen Sensors	8W-30	Turn Signal Lamps	8W-40, 50, 52, 52-4
Park Brake Switch	8W-45, 50	Turn Signal/Hazard Warning Switch	8W-52
Park Lamp Relay	8W-50	Underdrive Solenoid Control	8W-31
Park Lamps	8W-50, 52	Underhood Lamp	8W-44
Park/Neutral Position Switch	8W-44	Universal Garage Door Opener	8W-44
Passenger Seat Heater Control Module	8W-63	Upper Hose Coolant Switch	8W-30
Pedal Position Sensor	8W-30	Vehicle Information Center/ Graphic Display Module	8W-46
Power Amplifier	8W-47	Vehicle Speed Control Servo	8W-33
Power Antenna	8W-47	Vehicle Speed Control/Horn Switch	8W-39, 41
Power Antenna Relay	8W-47	Vehicle Speed Sensor	8W-31, 33
Power Distribution Center	8W-10	Visor/Vanity Lamps	8W-44
Power Outlet	8W-41	Volt Meter	8W-40
Power Seat Horizontal Motor Sensors	8W-63	Warning Lamps	8W-40
Power Seat Horizontal Motors	8W-63	Water In Fuel Sensor	8W-30
Power Seat Recliner Motor Sensors	8W-63	Wheel Speed Sensors	8W-35
Power Seat Recliner Motors	8W-63	Windshield Washer Pump Motor	8W-53
Power Seat Riser Motor Sensors	8W-63	Windshield Wiper Motor	8W-53
Power Seat Riser Motors	8W-63	Wiper Fluid Level Sensor	8W-46, 53
Power Seat Switches	8W-63		
Power Window Motors	8W-60		
Power Window Switches	8W-60		
Powertrain Control Module	8W-30		
Radio	8W-47		
Rear Fog Lamp Relay	8W-51		
Rear Washer Pump Motor	8W-53		

8W-10 POWER DISTRIBUTION

Component	Page	Component	Page
A/C Compressor Clutch.	8W-10-8	Fuse 10 (PDC).	8W-10-7, 13
A/C Compressor Clutch Relay	8W-10-8, 19, 22	Fuse 11 (JB)	8W-10-12
Automatic Headlamp Relay	8W-10-15	Fuse 11 (PDC).	8W-10-7, 14
Automatic Shutdown Relay	8W-10-19, 20, 22	Fuse 12 (JB)	8W-10-12
Battery	8W-10-7	Fuse 13 (JB)	8W-10-16
Blower Motor	8W-10-10	Fuse 13 (PDC).	8W-10-7, 15
Blower Power Module	8W-10-10	Fuse 14 (JB)	8W-10-13
Body Control Module	8W-10-19	Fuse 14 (PDC).	8W-10-7, 14
Brake Pressure Switch	8W-10-11	Fuse 15 (JB)	8W-10-13
Circuit Breaker 1	8W-10-13	Fuse 15 (PDC).	8W-10-7, 16
Circuit Breaker 2	8W-10-14	Fuse 16 (JB)	8W-10-16
Circuit Breaker 3	8W-10-16	Fuse 16 (PDC).	8W-10-7, 17, 18
Clutch Interlock Switch.	8W-10-11	Fuse 17 (JB)	8W-10-15
Clutch Interlock Switch Jumper	8W-10-11	Fuse 17 (PDC).	8W-10-7, 17
Controller Anti-Lock Brake	8W-10-9, 14	Fuse 18 (JB)	8W-10-13
Daytime Running Lamp Module	8W-10-15	Fuse 18 (PDC).	8W-10-12, 17, 18
Diagnostic Connector	8W-10-9, 19	Fuse 19 (PDC).	8W-10-7, 17, 18
Downstream Heated Oxygen Sensor	8W-10-21	Fuse 20 (JB)	8W-10-16
Duty Cycle Evap/Purge Solenoid.	8W-10-19	Fuse 20 (PDC).	8W-10-7, 20, 22
Electronic Vacuum Modulator	8W-10-23	Fuse 21 (JB)	8W-10-16
Engine Starter Motor	8W-10-10	Fuse 21 (PDC)	8W-10-8
Engine Starter Motor Relay	8W-10-10, 11	Fuse 22 (JB)	8W-10-12
Fog Lamp Relay	8W-10-17, 18	Fusible Link	8W-10-7, 8
Fuel Heater Relay.	8W-10-19, 22	Generator	8W-10-8, 23
Fuel Injector No. 1	8W-10-21	Glow Plug Relay	8W-10-23
Fuel Injector No. 2	8W-10-21	Headlamp Dimmer Switch	8W-10-15
Fuel Injector No. 3	8W-10-21	Headlamp Switch	8W-10-15, 17, 18
Fuel Injector No. 4	8W-10-21	High Speed Cooling Fan Relay	8W-10-9
Fuel Injector No. 5	8W-10-21	Horn No. 1	8W-10-9
Fuel Injector No. 6	8W-10-21	Horn No. 2	8W-10-9
Fuel Injector No. 7	8W-10-21	Horn Relay	8W-10-9
Fuel Injector No. 8	8W-10-21	Ignition Coil	8W-10-21
Fuel Pump Module	8W-10-17, 23	Ignition Relay	8W-10-19
Fuel Pump Relay.	8W-10-17, 19	Ignition Switch	8W-10-10, 11, 12, 13
Fuse 1 (JB)	8W-10-13	Junction Block	8W-10-8, 12, 13, 14, 15, 16, 17, 18
Fuse 2 (JB)	8W-10-13	Leak Detection Pump	8W-10-19
Fuse 2 (PDC)	8W-10-7, 9	Left Fog Lamp.	8W-10-17, 28
Fuse 3 (JB)	8W-10-13	Low Speed Cooling Fan Relay.	8W-10-9
Fuse 3 (PDC)	8W-10-7, 8	Mass Air Flow Module	8W-10-23
Fuse 4 (JB)	8W-10-12	MSA Controller	8W-10-19, 22, 23
Fuse 4 (PDC)	8W-10-7, -22	Power Distribution Center	8W-10-7, 8, 9, 10, 11, 12, 13, 14, 15, 16, 17, 18, 20, 22
Fuse 5 (JB)	8W-10-12	Powertrain Control Module	8W-10-18, 19, 20, 23
Fuse 5 (PDC)	8W-10-7, 9	Rear Fog Lamp Relay	8W-10-13
Fuse 6 (JB)	8W-10-12	Rear Window Defogger	8W-10-8
Fuse 6 (PDC)	8W-10-7, 9	Rear Window Defogger Relay	8W-10-8
Fuse 7 (JB)	8W-10-14	Right Fog Lamp	8W-10-17, 18
Fuse 7 (PDC).	8W-10-7, 10	Transmission Control Relay	8W-10-17
Fuse 8 (JB)	8W-10-14	Transmission Solenoid Assembly.	8W-10-17
Fuse 8 (PDC).	8W-10-7, 10, 11	Upstream Heated Oxygen Sensor	8W-10-21
Fuse 9 (JB)	8W-10-14		
Fuse 10 (JB)	8W-10-8		



FUSES

FUSE NO.	AMPS	FUSED CIRCUIT	FEED CIRCUIT
1	-	-	-
2 ■	60	F143 10LG/RD	A0 6RD
3	40	A900 12OR/YL	A0 6RD
		A900 16OR/YL	
4 **	30	A12 12RD/TN	A0 6RD
5	40	A10 12RD/DB	A0 6RD
6	20	F31 16VT	A0 6RD
7	40	A19 12RD/VT	A0 6RD
8	40	A1 12RD/WT	A0 6RD
		A1 12RD/WT	
9	-	-	SPARE
10	20	F61 16WT/OR	A0 6RD
11	50	A250 10RD	A0 6RD
12	-	-	SPARE
13	30	A6 14RD/LB	A0 6RD
		A6 14RD/LB •	
14	20	A20 14RD/LG	A0 6RD
15	40	A7 12YL/RD	A0 6RD
16 *	20	A61 16DG/BK	A0 6RD
16 **	15	F6 18WT/RD	A0 6RD
17	15	F92 18LG	A0 6RD
18	15	F99 18OR	A21 12DB/GY
19	20	F62 18RD	A0 6RD
20 *	20	F5 14RD/YL	A0 6RD
20 **	25	F5 16RD/YL	A0 6RD
21	15	F250 18RD/GY	A900 16OR/YL

* GAS

** DIESEL

• DRL

■ MAX COOLING

**A/C
COMPRESSOR
CLUTCH
RELAY**

CAV	CIRCUIT	FUNCTION
B1	F250 18RD/GY	FUSED B(+)
B2	C2 18DB/YL	A/C COMPRESSOR CLUTCH RELAY OUTPUT
B3 *	F99 20OR	FUSED IGNITION SWITCH OUPUT (ST-RUN)
B3 **	A142 16DG/OR	AUTOMATIC SHUT DOWN RELAY OUTPUT
B4	-	-
B5 *	C13 18DB/RD	A/C COMPRESSOR CLUTCH RELAY CONTROL
B5 **	C13 18DB/BK	A/C COMPRESSOR CLUTCH RELAY CONTROL

**AUTOMATIC
SHUT DOWN
RELAY**

CAV	CIRCUIT	FUNCTION
B16 *	F5 18RD/YL	FUSED B(+)
B16 **	F5 16RD/YL	FUSED B(+)
	F5 16RD/YL	FUSED B(+)
B17 *	A142 18DG/OR	AUTOMATIC SHUT DOWN RELAY OUTPUT
	A142 18DG/OR	AUTOMATIC SHUT DOWN RELAY OUTPUT
B17 **	A142 16DG/OR	AUTOMATIC SHUT DOWN RELAY OUTPUT
	A142 16DG/OR	AUTOMATIC SHUT DOWN RELAY OUTPUT
B18 *	F99 20OR	FUSED IGNITION SWITCH OUTPUT (ST-RUN)
B18 **	F5 16RD/YL	FUSED B(+)
B19	-	-
B20 *	K900 18PK/WT	AUTOMATIC SHUT DOWN RELAY CONTROL
B20 **	K900 20PK/BK	AUTOMATIC SHUT DOWN RELAY CONTROL

* GAS
** DIESEL

ENGINE
STARTER
MOTOR
RELAY

CAV	CIRCUIT	FUNCTION
C6	A1 12RD/WT	FUSED B(+)
C7	T40 12LG/BK	ENGINE STARTER MOTOR RELAY OUTPUT
C8	T141 14YL/RD	FUSED IGNITION (ST)
C9	-	-
C10	T41 20BK/WT *	PARK NEUTRAL POSITION SWITCH SENSE
C10	Z4 20BK **	GROUND

FUEL
HEATER
RELAY
(DIESEL)

CAV	CIRCUIT	FUNCTION
D10	A12 12RD/TN	FUSED B(+)
D11	Z4 20BK	GROUND
D12	-	-
D13	F99 20OR	FUSED IGNITION (ST-RUN)
D14	A64 14OR/DB	FUEL HEATER RELAY OUTPUT

FUEL
PUMP
RELAY
(GAS)

CAV	CIRCUIT	FUNCTION
C16	A61 16DG/BK	FUSED B(+)
C17	A64 16DG/WT	FUEL PUMP RELAY OUTPUT
C18	F99 20OR	FUSED IGNITION (ST-RUN)
C19	-	-
C20	K81 18DB	FUEL PUMP RELAY CONTROL

* GAS
** DIESEL

**HORN
RELAY**

CAV	CIRCUIT	FUNCTION
A1	F31 16VT	FUSED B(+)
A2	X2 16DG/YL	HORN RELAY OUTPUT
A3	F31 16VT	FUSED B(+)
	F31 16VT	FUSED B(+)
A4	-	-
A5	X4 20GY/OR	HORN RELAY CONTROL

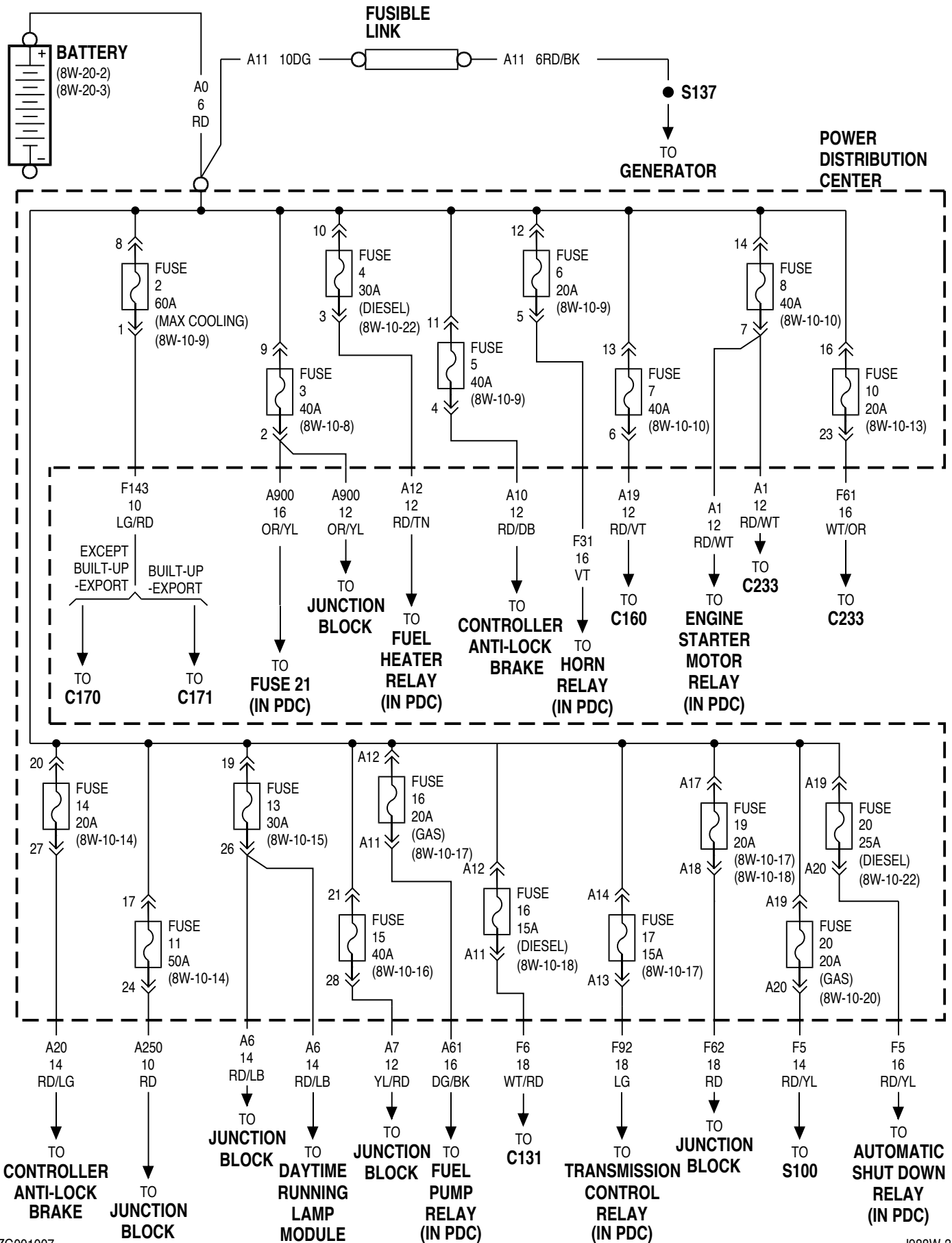
**INTERMITTENT
WIPER
RELAY**

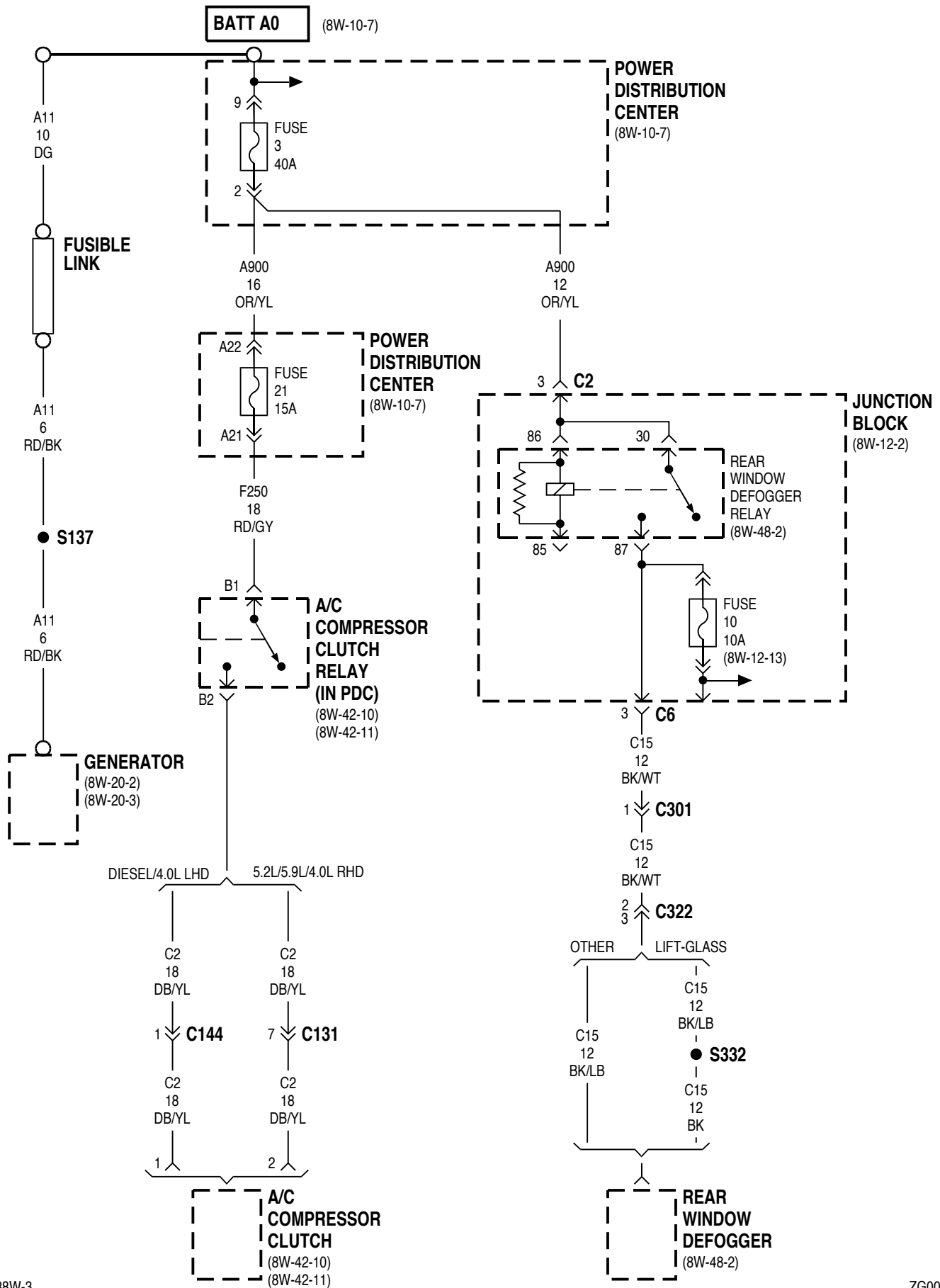
CAV	CIRCUIT	FUNCTION
C1	V6 16DB	WIPER PARK SWITCH SENSE
C2	F86 16LG/RD	FUSED B(+)
	F86 16LG/RD *	FUSED B(+)
C3 *	F86 16LG/RD	FUSED B(+)
C3 **	F86 16LG/BK	FUSED B(+)
C4 *	V66 18VT/WT	WIPER PARK SWITCH SENSE
C4 **	V66 16VT/WT	WIPER PARK SWITCH SENSE
C5	V18 20YL/LG	INTERMITTENT WIPER RELAY CONTROL

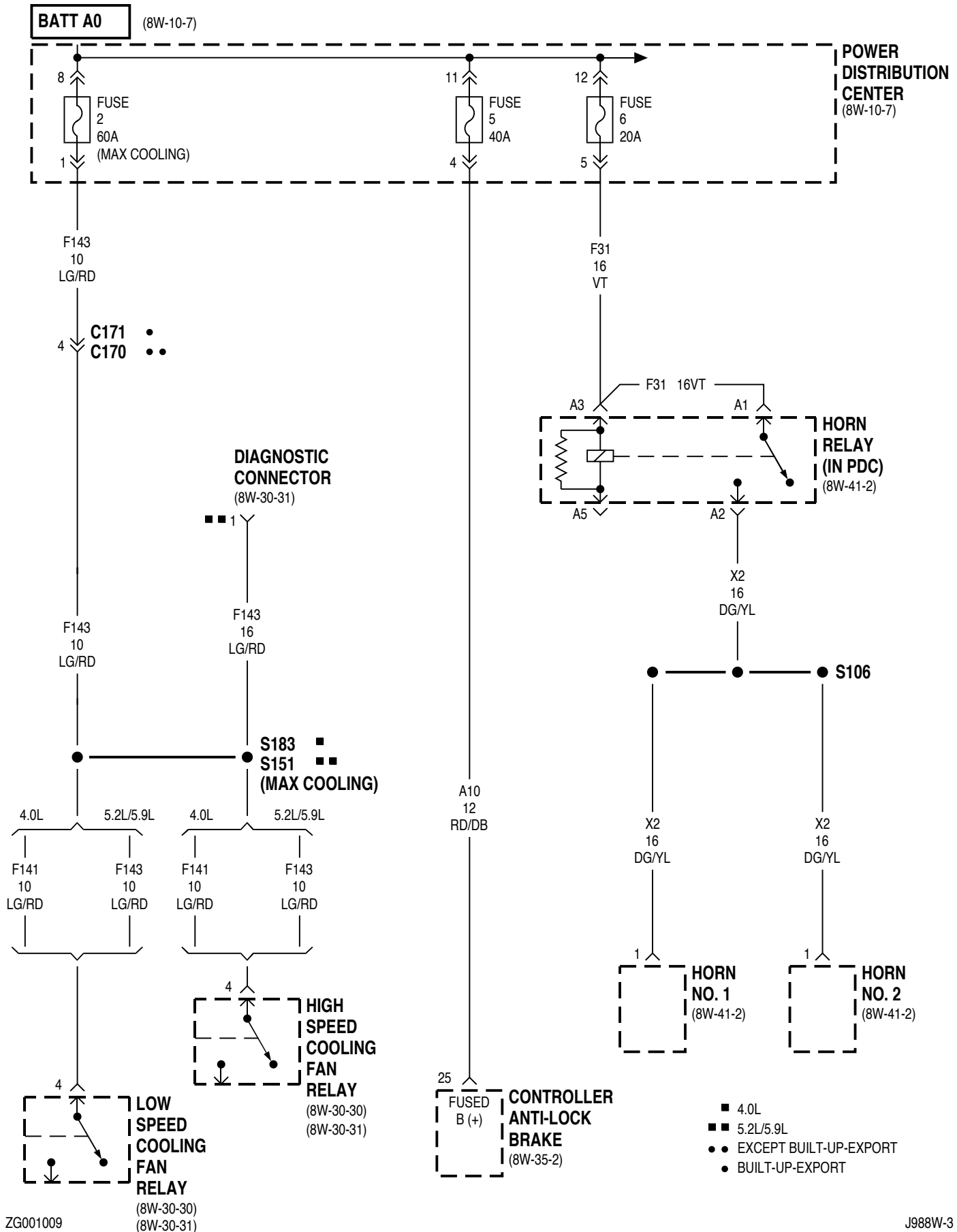
**TRANSMISSION
CONTROL
RELAY**

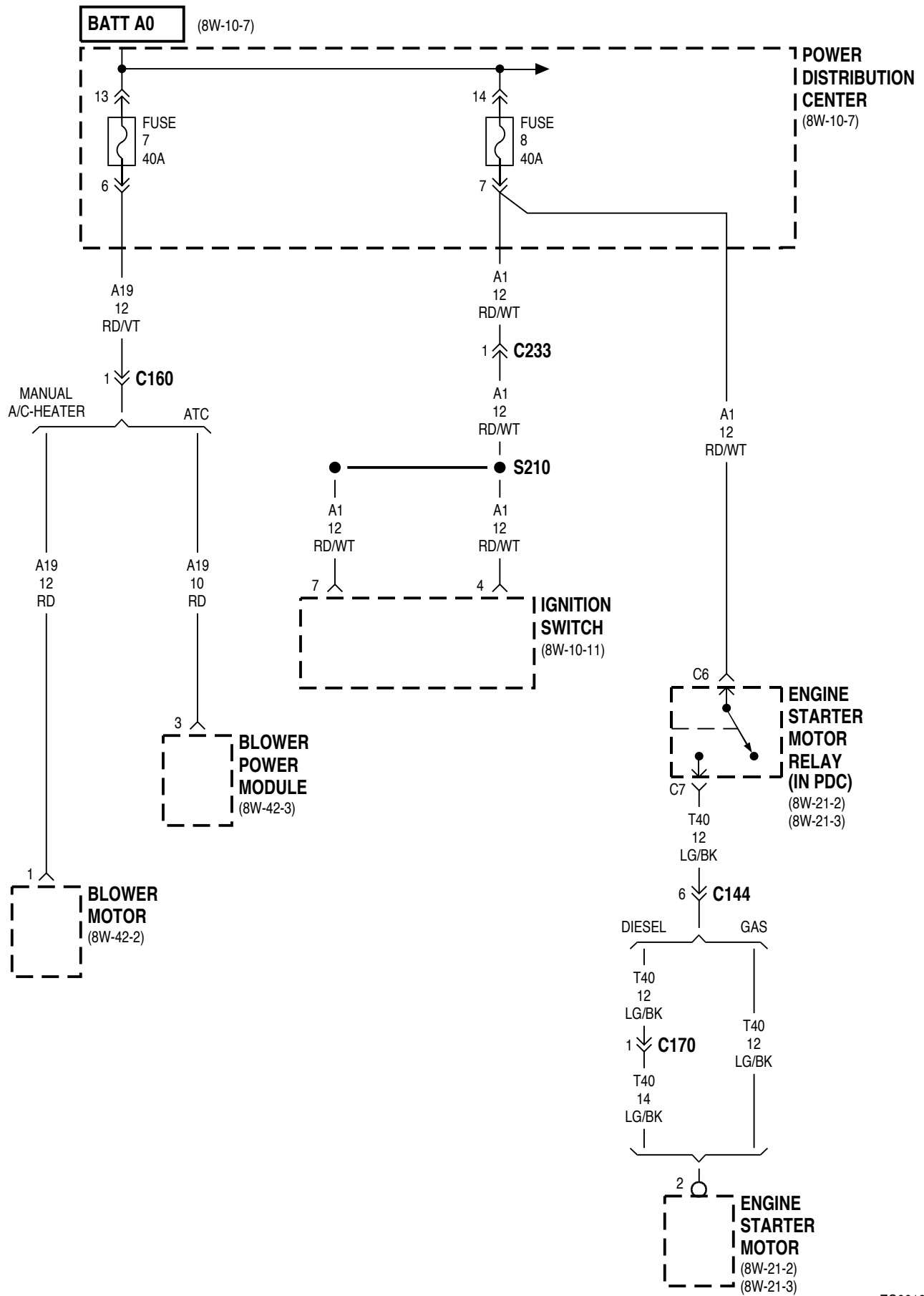
CAV	CIRCUIT	FUNCTION
A6	F92 18LG	FUSED B(+)
A7	T20 18LB	TRANSMISSION CONTROL RELAY OUTPUT
A8	K72 18DG/VT	GENERATOR DRIVER
	K72 18DG/VT	GENERATOR DRIVER
A9	-	-
A10	T66 20BR/OR	TRANSMISSION CONTROL RELAY OUTPUT

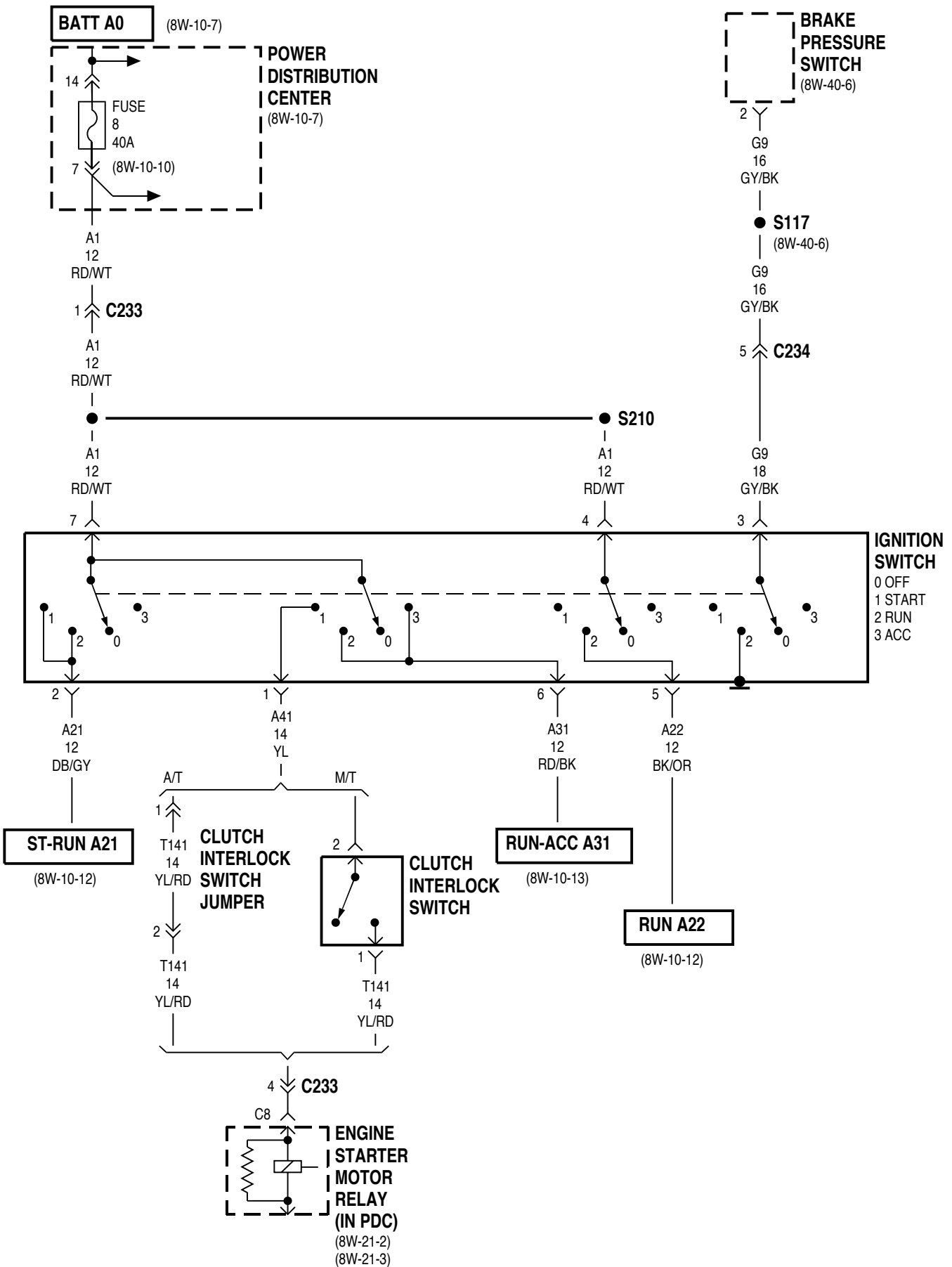
* GAS
** DIESEL

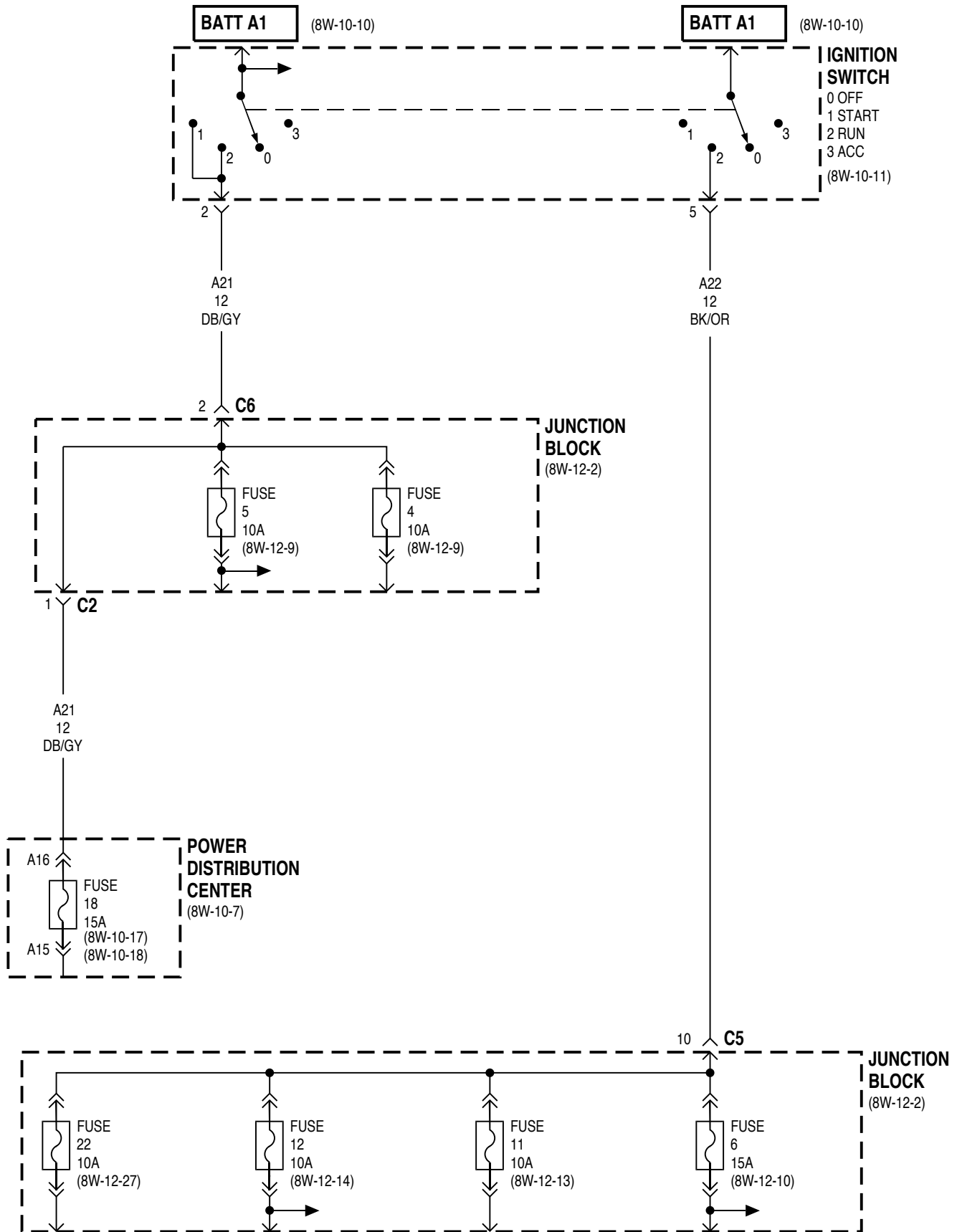


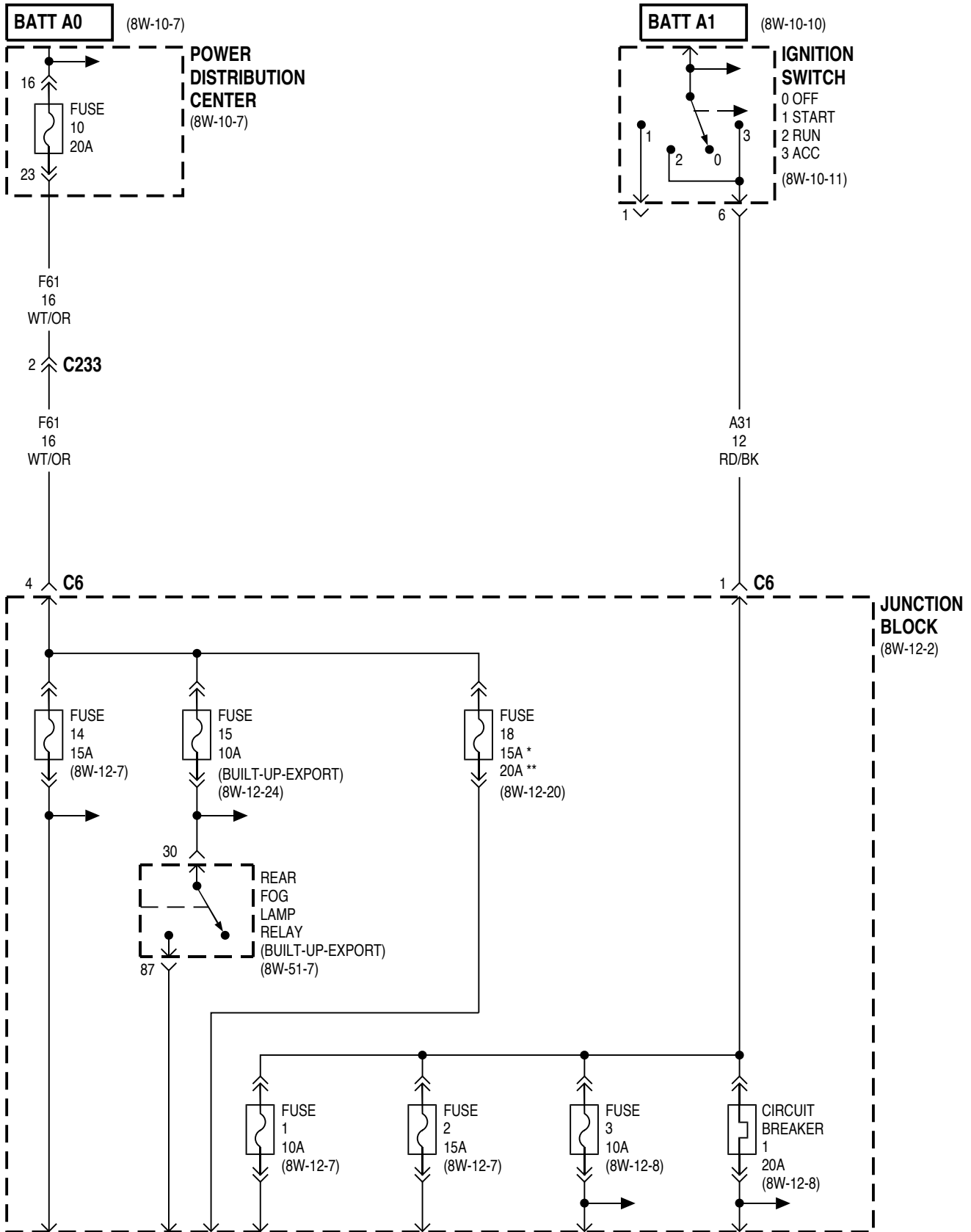






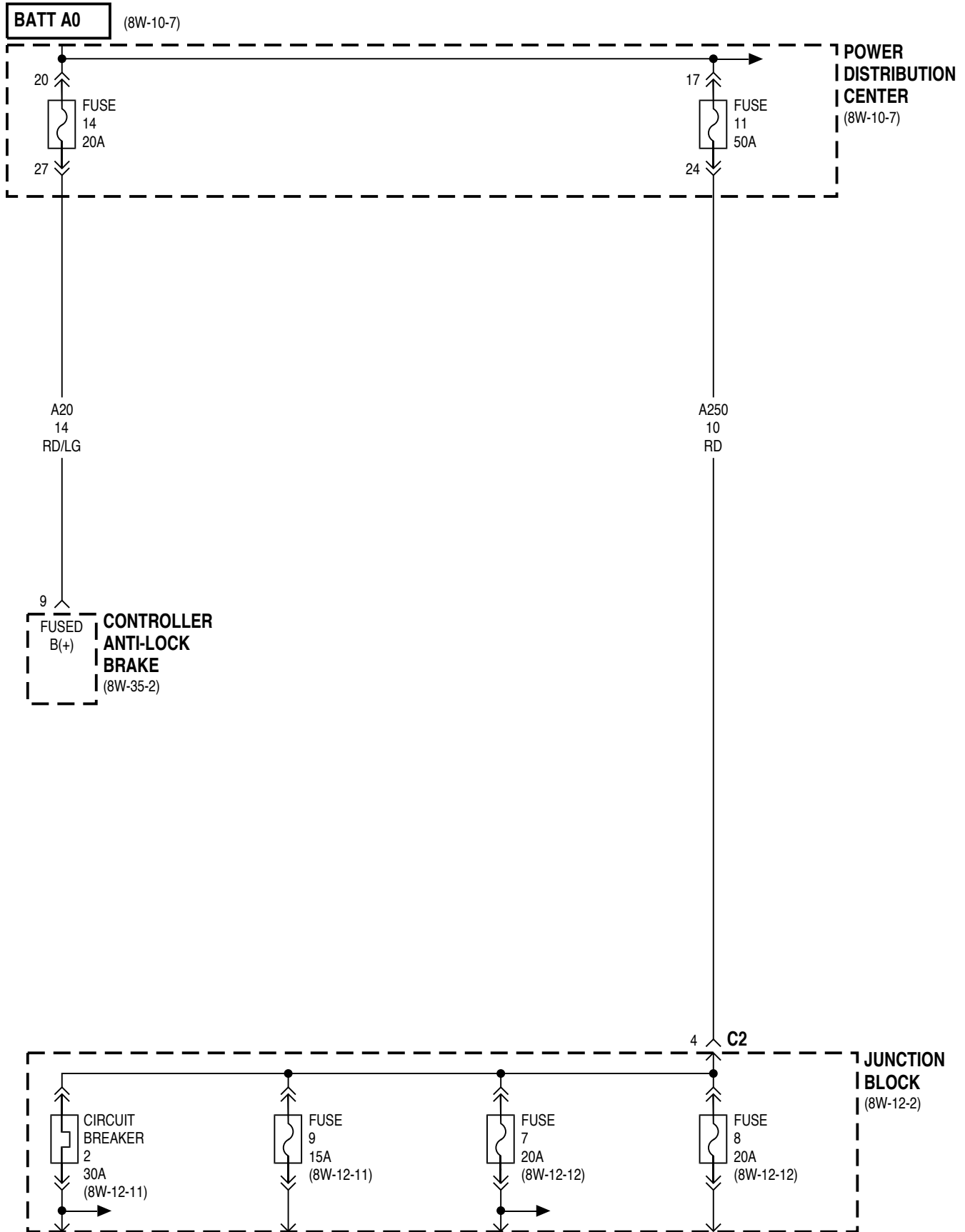


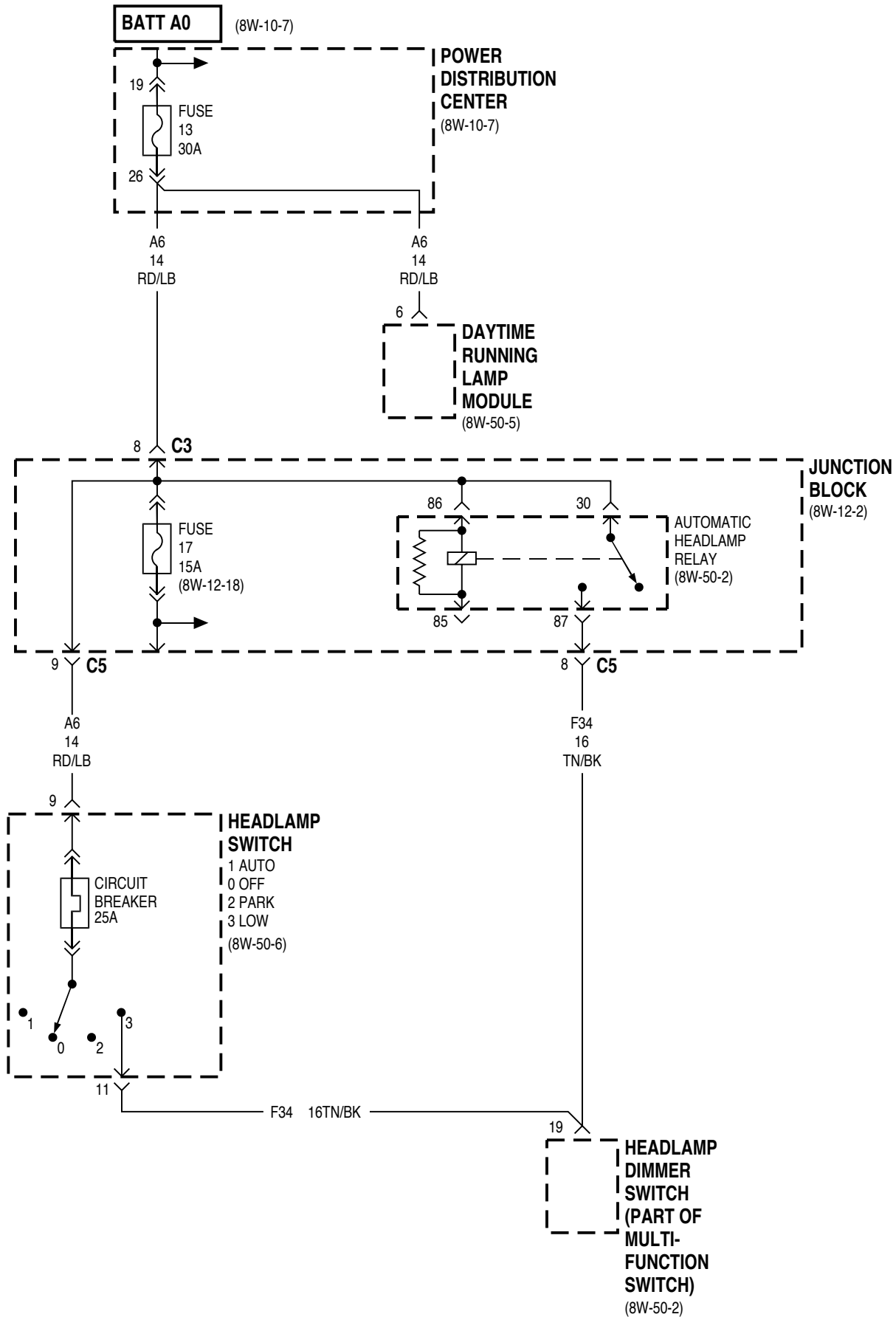


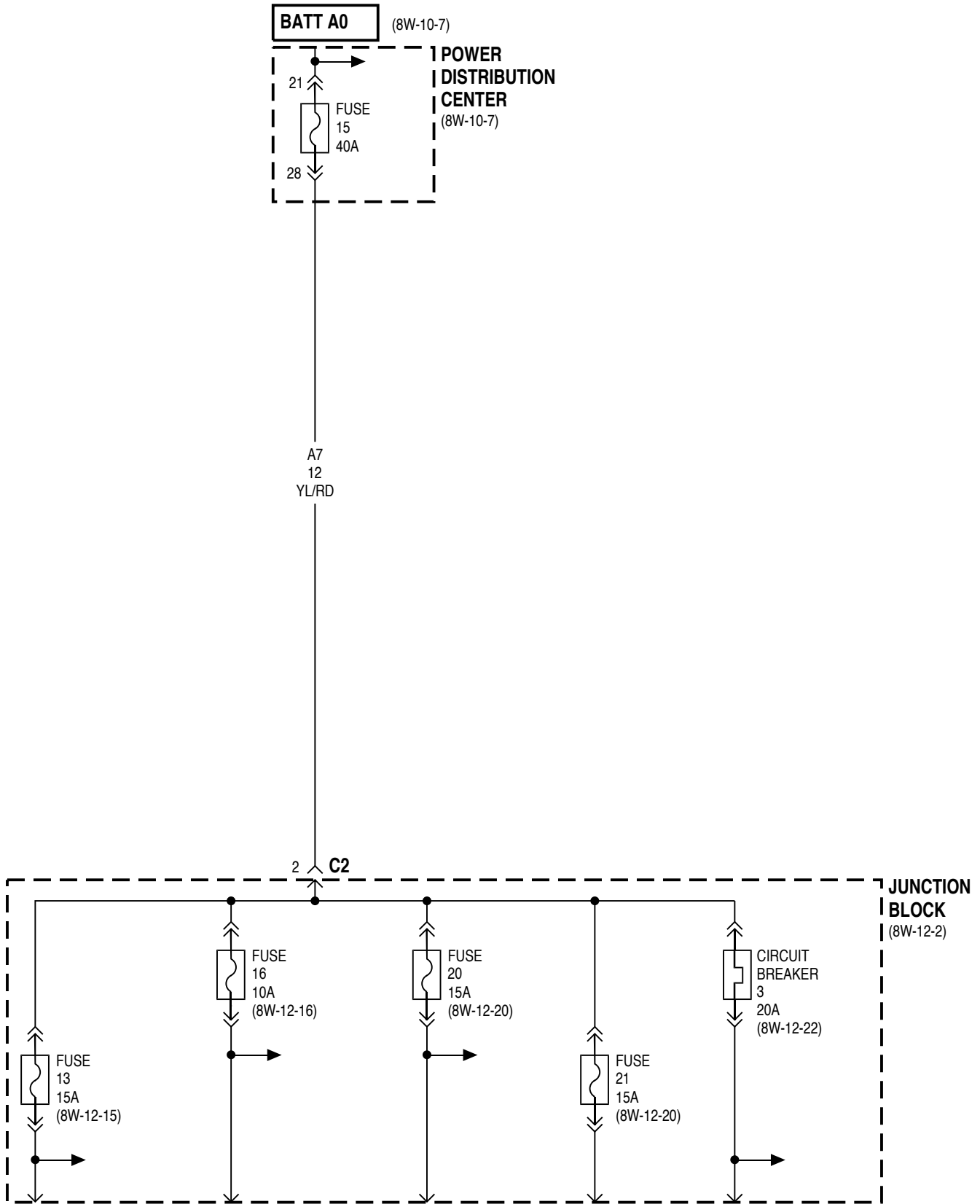


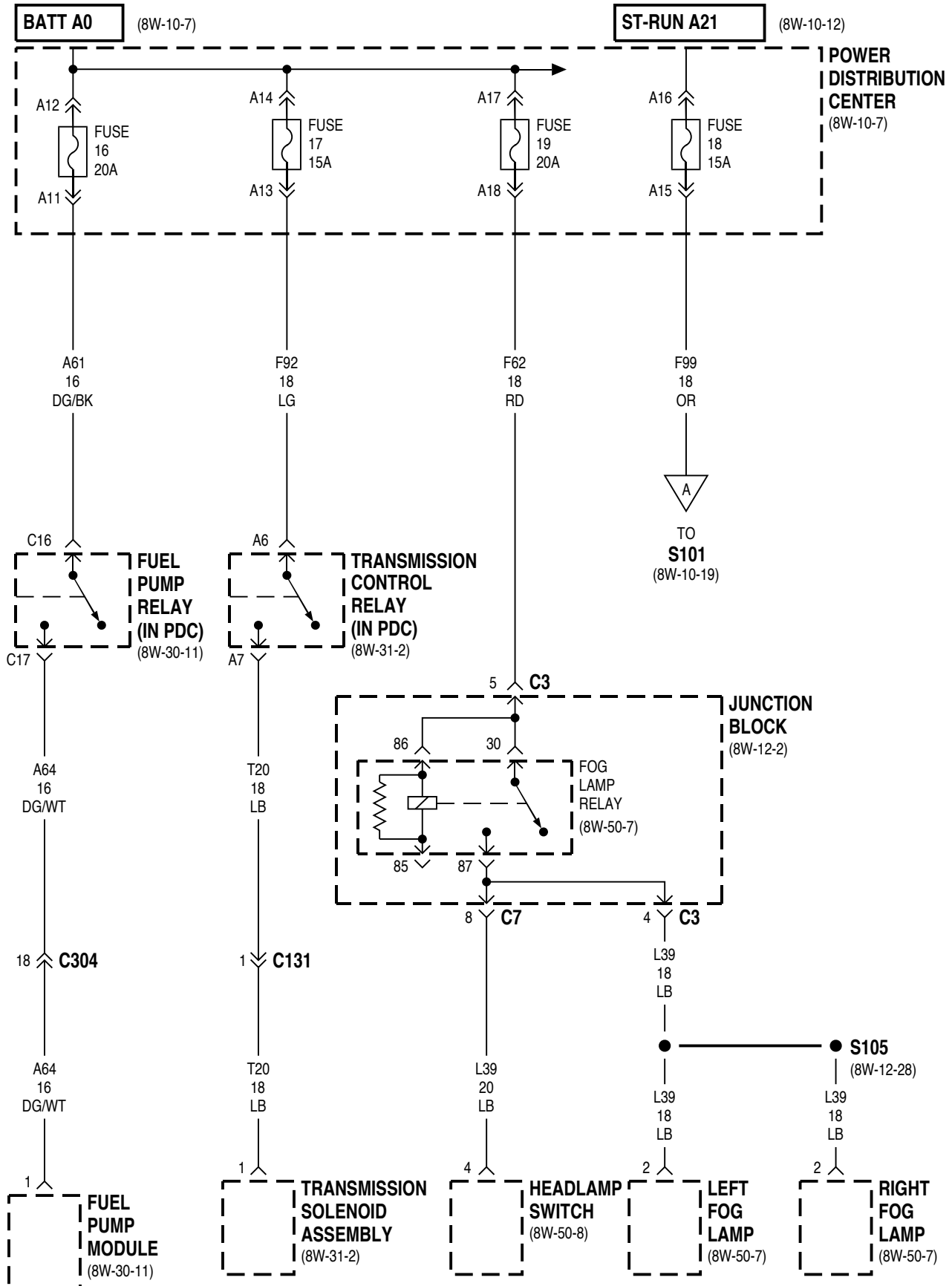
* GAS

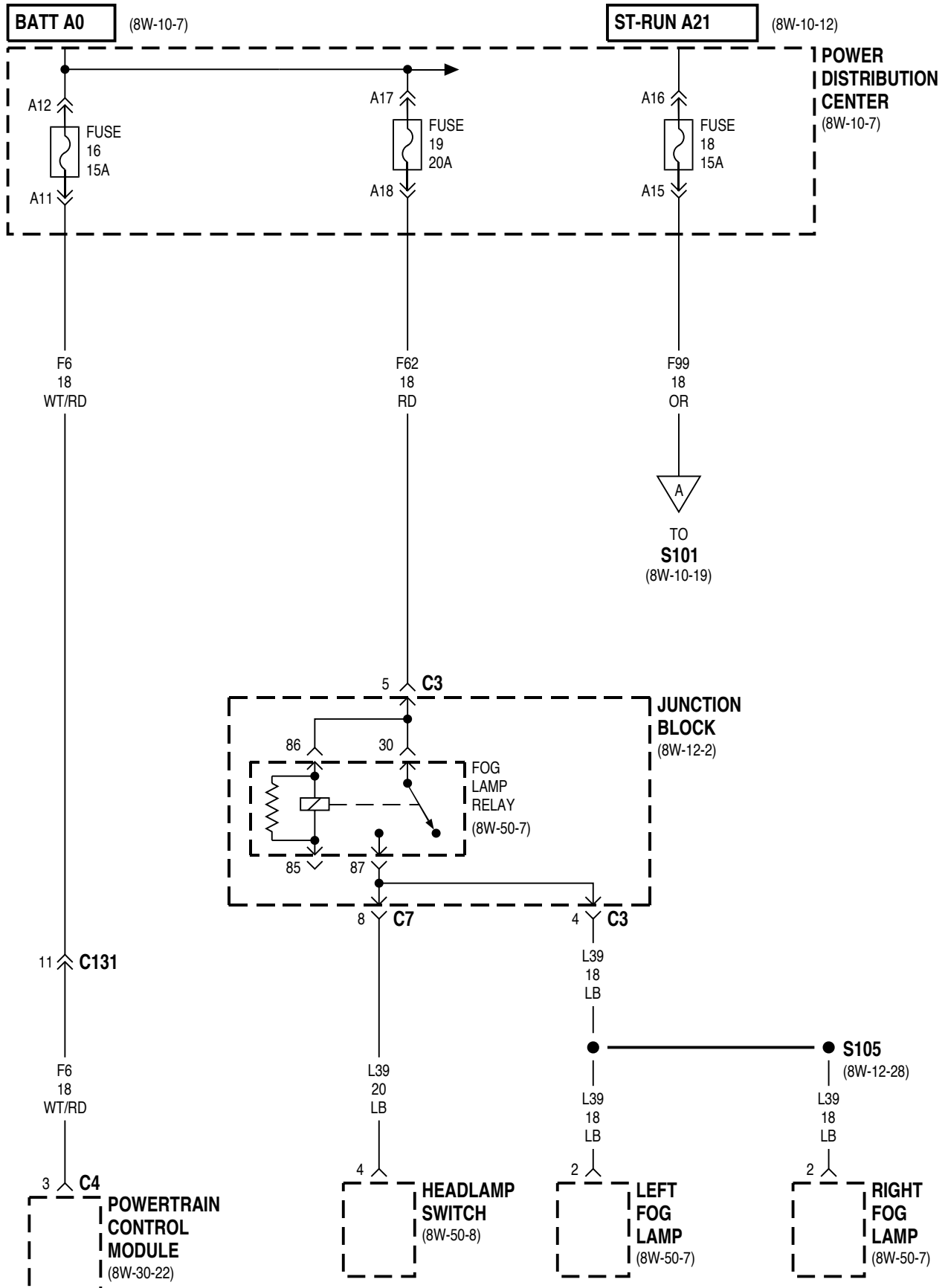
** DIESEL

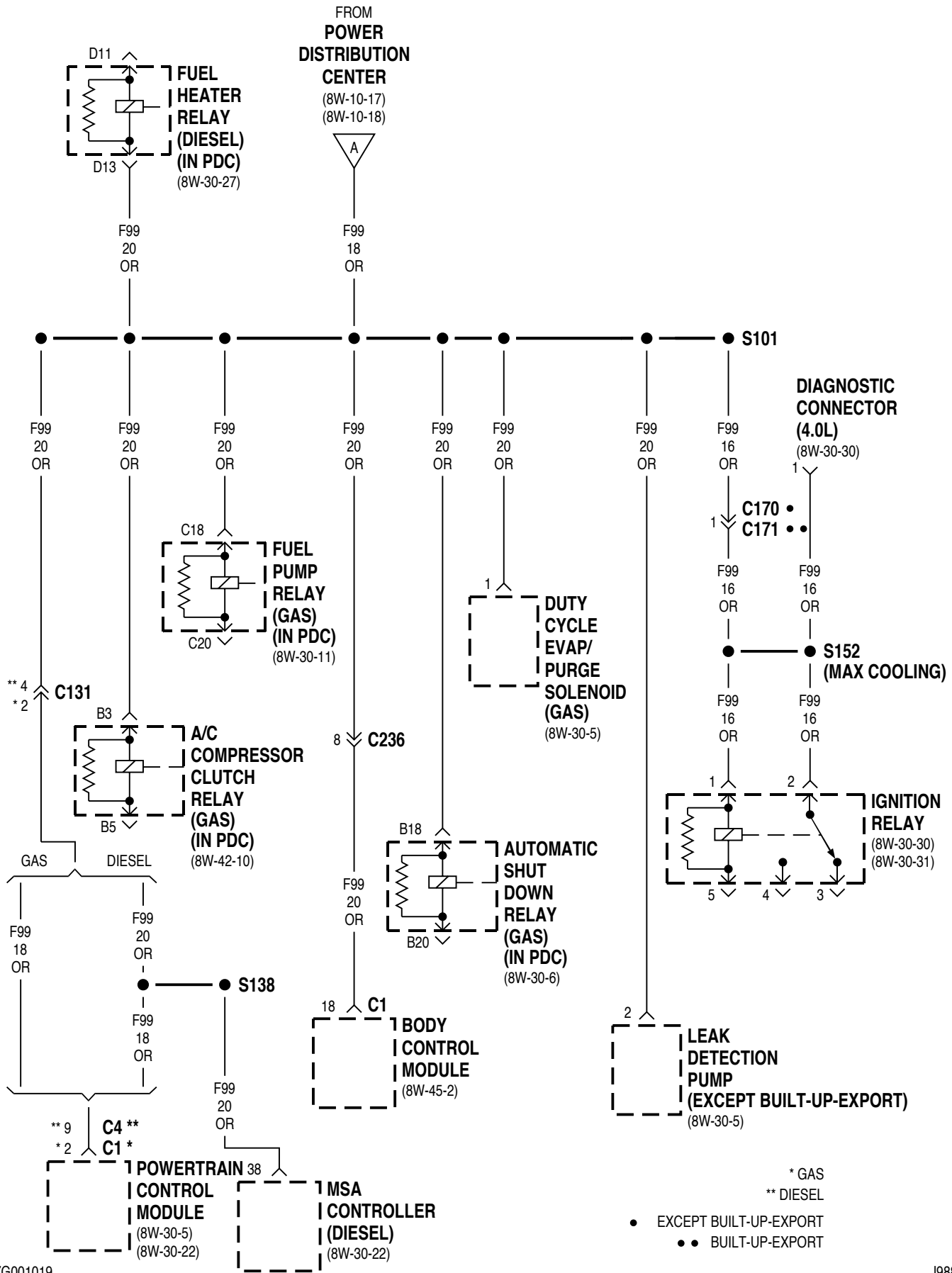


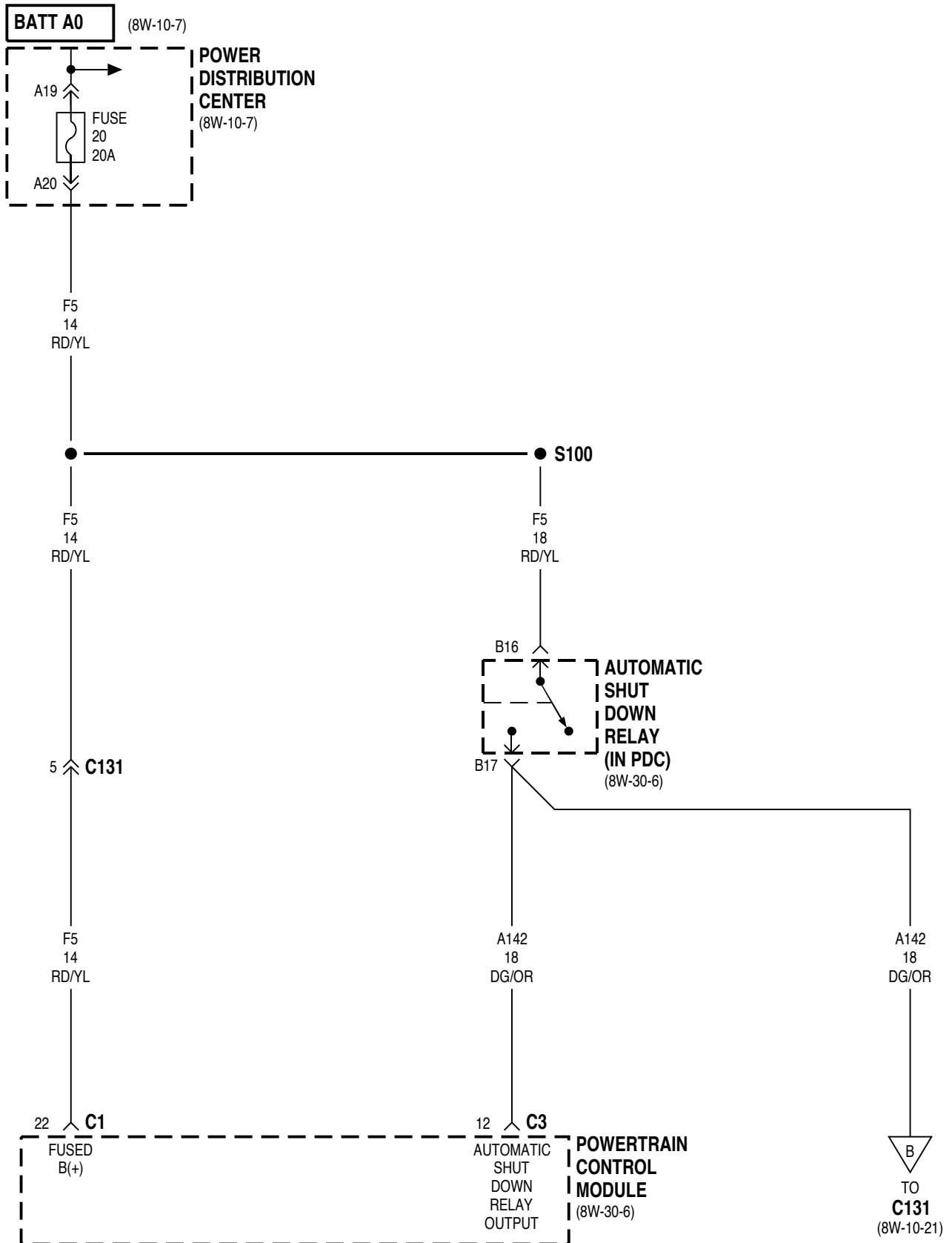


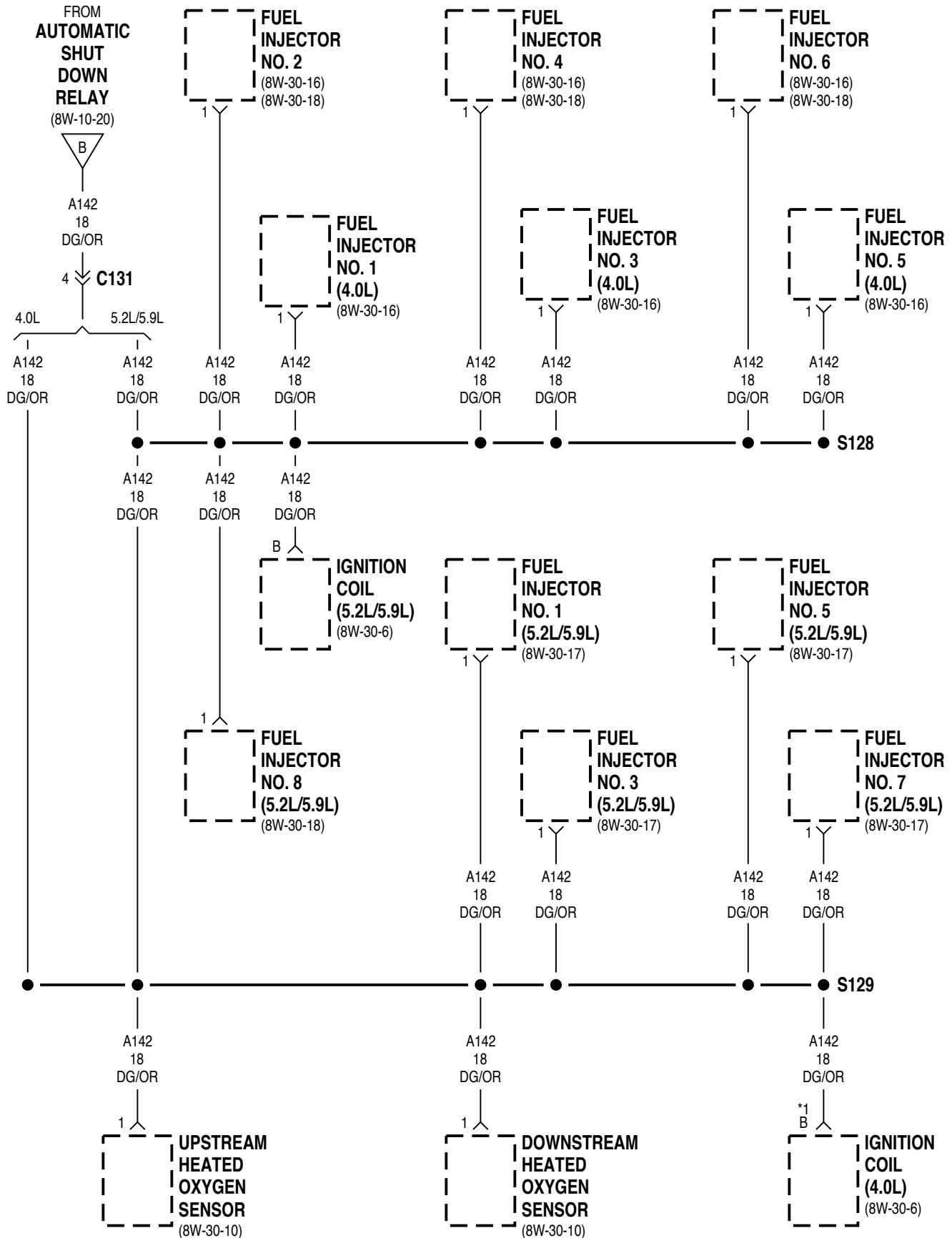




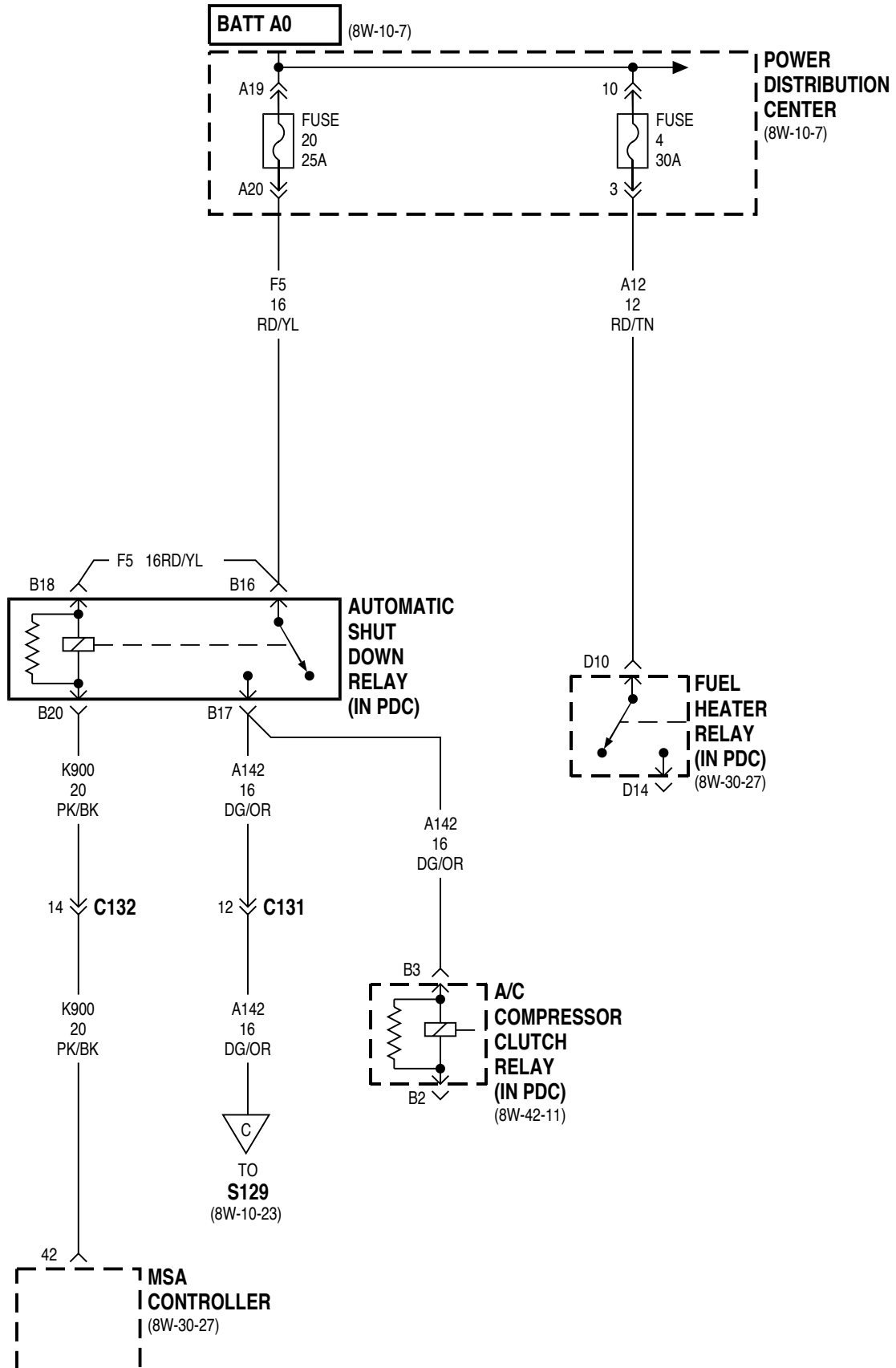


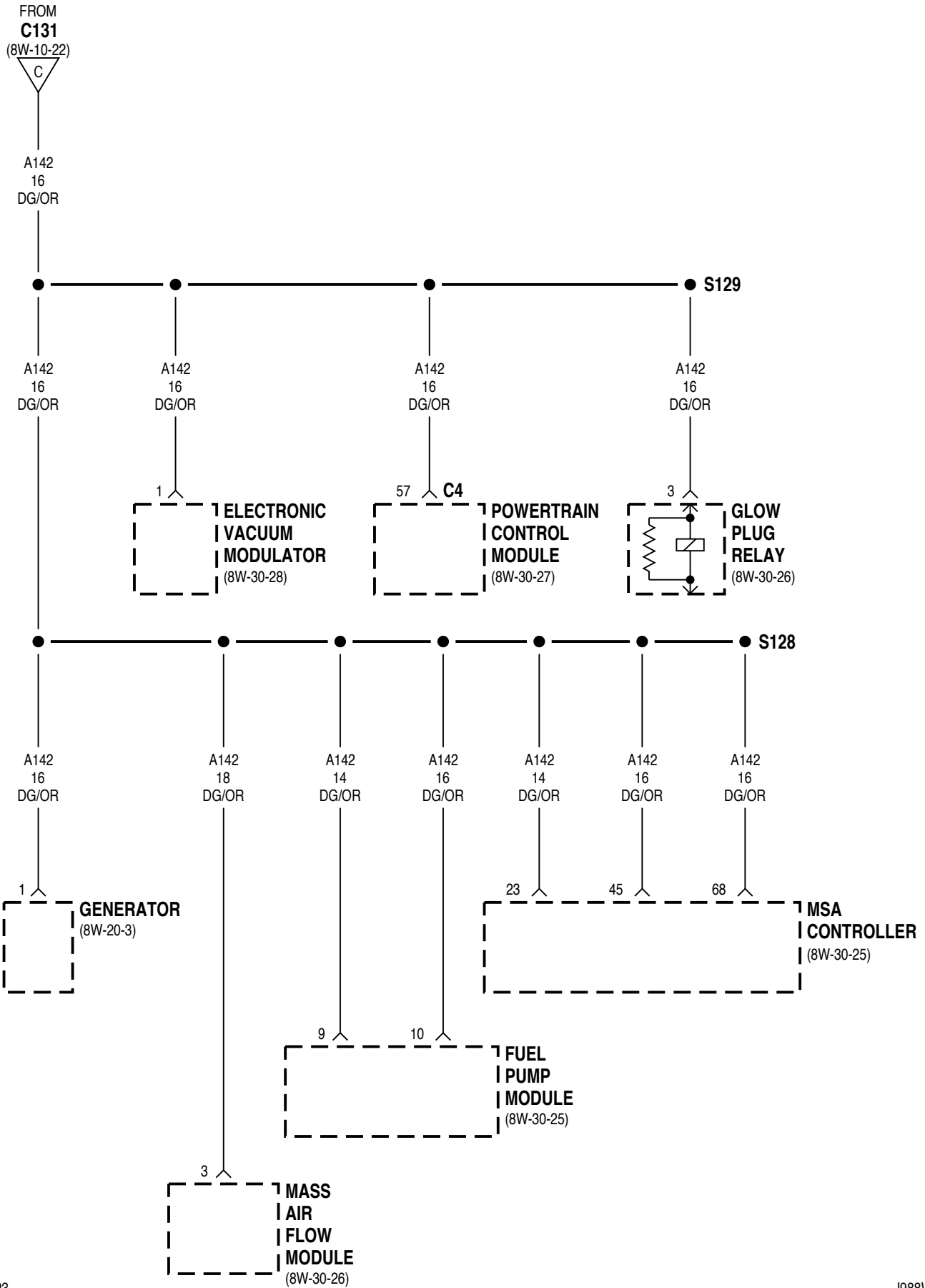






* RHD

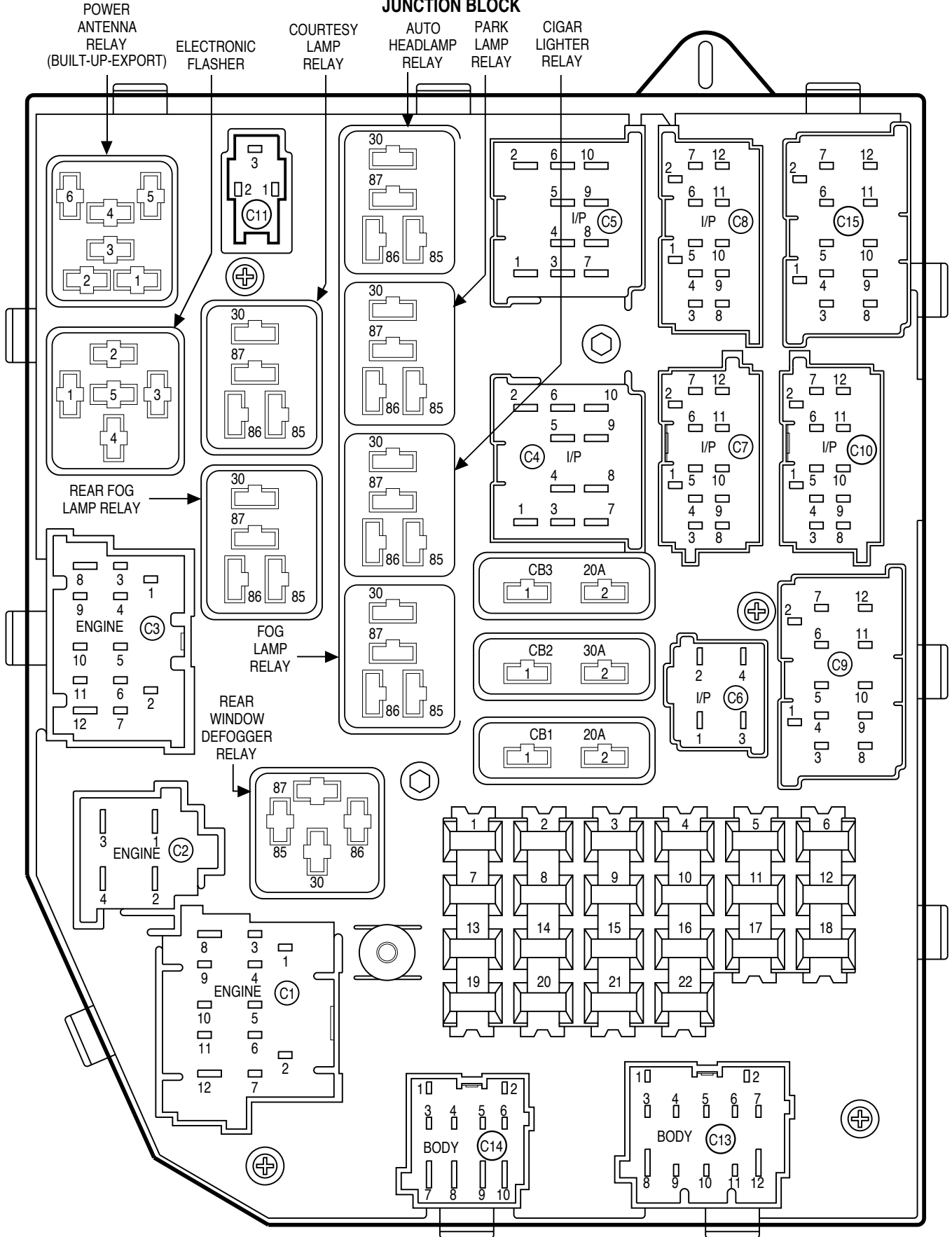




8W-12 JUNCTION BLOCK

Component	Page	Component	Page
A/C Heater Control	8W-12-14	Glove Box Lamp	8W-12-16
Aftermarket Trailer Tow Connector	8W-12-12	Headlamp Dimmer Switch	8W-12-10, 20, 28
Airbag Control Module	8W-12-9, 27	Headlamp Switch	8W-12-18, 24, 28
Automatic Day/Night Mirror.	8W-12-11, 21, 25	Horn Relay	8W-12-27
Automatic Headlamp Light Sensor/VTSS LED	8W-12-12	Instrument Cluster	8W-12-9, 12, 21
Automatic Headlamp Relay	8W-12-28	Intermittent Wiper Relay	8W-12-8
Automatic Temperature Control Module	8W-12-14, 20	Intermittent Wiper Switch	8W-12-8
Back-Up Lamp Switch	8W-12-10, 21	Junction Block.	8W-12-2, 7, 8, 9, 10, 11, 12, 13, 14, 15, 16, 18, 19, 20, 21, 22, 23, 24, 26, 27, 28
Blend Door Actuator	8W-12-14	Key-In Switch/Halo Lamp	8W-12-16, 26
Body Control Module	8W-12-8, 12, 13, 18, 26, 27, 28	Lamp Outage Module	8W-12-9, 19, 24
Cargo Lamp.	8W-12-16, 26	Left Back-Up Lamp	8W-12-21
Cigar Lighter	8W-12-7	Left Courtesy Lamp	8W-12-16, 26
Cigar Lighter Relay.	8W-12-7	Left Fog Lamp	8W-12-28
Cigar Lighter/Power Outlet.	8W-12-7, 20	Left Visor/Vanity Lamp.	8W-12-17, 25
Circuit Breaker 1	8W-12-8	Liftglass Limit Switch	8W-12-12
Circuit Breaker 2.	8W-12-11	Memory Seat Module.	8W-12-22
Circuit Breaker 3	8W-12-22	Overhead Console	8W-12-11, 17, 25
Clockspring	8W-12-27	Park Lamp Relay	8W-12-18
Controller Anti-Lock Brake.	8W-12-13	Park/Neutral Position Switch.	8W-12-10, 21
Courtesy Lamp Relay	8W-12-16, 26	Passenger Door Module	8W-12-11
Data Link Connector	8W-12-12	Passenger Lumbar Switch	8W-12-22
Daytime Running Lamp Module	8W-12-10	Passenger Power Seat Switch	8W-12-22
Dome/Reading Lamp.	8W-12-17, 25	Passenger Seat Heater Control Module.	8W-12-14, 22
Driver Door Module	8W-12-11	Power Amplifier.	8W-12-12, 15
Driver Lumbar Switch	8W-12-22	Power Antenna	8W-12-15
Driver Power Seat Switch.	8W-12-22	Power Antenna Relay.	8W-12-15
Driver Seat Heater Control Module	8W-12-14, 22	Power Distribution Center	8W-12-9
Electronic Flasher	8W-12-10, 15	Power Outlet	8W-12-20
Factory Trailer Tow Connector	8W-12-21	Radio	8W-12-7, 15, 19, 20
Fog Lamp Relay	8W-12-28	Rear Fog Lamp Relay	8W-12-24
Four Wheel Drive Switch	8W-12-23	Rear Window Defogger.	8W-12-13
Fuse 1 (JB)	8W-12-7	Rear Window Defogger Relay	8W-12-13
Fuse 2 (JB)	8W-12-7	Rear Window Defogger Switch	8W-12-13
Fuse 3 (JB)	8W-12-8	Rear Wiper Module	8W-12-12
Fuse 4 (JB)	8W-12-9	Rear Wiper/Washer Switch.	8W-12-8
Fuse 5 (JB)	8W-12-9	Recirculation Door Actuator	8W-12-14
Fuse 6 (JB).	8W-12-10	Right Back-Up Lamp	8W-12-21
Fuse 7 (JB).	8W-12-12	Right Courtesy Lamp	8W-12-16, 26
Fuse 8 (JB).	8W-12-12	Right Fog Lamp	8W-12-28
Fuse 9 (JB).	8W-12-11	Right Front Turn Signal Lamp	8W-12-21
Fuse 10 (JB).	8W-12-13	Right Side Repeater.	8W-12-21
Fuse 11 (JB).	8W-12-13	Right Visor/Vanity Lamp	8W-12-17, 25
Fuse 12 (JB).	8W-12-14	Shift Interlock	8W-12-9
Fuse 13 (JB).	8W-12-15	Stop Lamp Switch	8W-12-11
Fuse 14 (JB).	8W-12-7	Sunroof Control Module	8W-12-9, 25
Fuse 15 (JB).	8W-12-24	Sunroof Switch	8W-12-9
Fuse 16 (JB).	8W-12-16	Switch Pod	8W-12-14
Fuse 17 (JB).	8W-12-18	Trailer Tow Circuit Breaker	8W-12-12
Fuse 18 (JB).	8W-12-20	Turn Signal/Hazard Warning Switch.	8W-12-15, 21
Fuse 18 (PDC)	8W-12-9	Underhood Lamp.	8W-12-16
Fuse 20 (JB).	8W-12-20	Vehicle Information Center/ Graphic Display Module	8W-12-10, 15, 19, 20, 23
Fuse 21 (JB).	8W-12-20	Windshield Wiper Motor	8W-12-8
Fuse 22 (JB).	8W-12-27		
G303	8W-12-15, 26		

TOP OF
JUNCTION BLOCK



FUSES

FUSE NO.	AMPS	FUSED CIRCUIT	FEED CIRCUIT
1	10A	X12 18RD/GY	INTERNAL
2	15A	A31 18RD/BK	INTERNAL
3	10A	INTERNAL	INTERNAL
4	10A	G5 18DB/WT	INTERNAL
5	10A	INTERNAL	INTERNAL
6	15A	INTERNAL	INTERNAL
7	20A	INTERNAL	INTERNAL
8	20A	F70 14PK/BK	INTERNAL
9	15A	L16 18RD/LG	INTERNAL
10	10A	INTERNAL	INTERNAL
11 *	10A	F12 18DB/WT	INTERNAL
11 **	10A	F12 20DB/WT	INTERNAL
12	10A	INTERNAL	INTERNAL
13	15A	INTERNAL	INTERNAL
14	15A	INTERNAL	INTERNAL
15 •	10A	INTERNAL	INTERNAL
16	10A	INTERNAL	INTERNAL
17	15A	INTERNAL	INTERNAL
18 *	15A	L11 16LG/BK	INTERNAL
18 **	20A	L11 16LG/BK	INTERNAL
19	-	-	-
20	15A	INTERNAL	INTERNAL
21	15A	F38 18OR	INTERNAL
22	10A	F20 18WT	INTERNAL

* GAS

** DIESEL

• BUILT-UP-EXPORT

CIRCUIT BREAKERS

CIRCUIT BREAKER	AMPS	FUSED CIRCUIT	FEED CIRCUIT
1	20A	INTERNAL	INTERNAL
2	30A	INTERNAL	INTERNAL
3	20A	INTERNAL	INTERNAL

ELECTRONIC
FLASHER

CAVITY	CIRCUIT	FUNCTION
1	INTERNAL	FUSED B(+)
2	L5 18OR/BK	TURN SIGNAL
3	INTERNAL	GROUND
4	INTERNAL	FUSED IGNITION (RUN)
5	L12 18VT/TN	HAZARD SIGNAL

AUTOMATIC
HEADLAMP
RELAY

CAVITY	CIRCUIT	FUNCTION
30	INTERNAL	FUSED B(+)
85	714 20BK/OR	AUTOMATIC HEADLAMP RELAY CONTROL
86	INTERNAL	FUSED B(+)
87	F34 16TN/BK	AUTOMATIC HEADLAMP RELAY OUTPUT

**CIGAR
LIGHTER
RELAY**

CAVITY	CIRCUIT	FUNCTION
30	INTERNAL	FUSED B(+)
85	Z1 18BK	GROUND
86	A31 18RD/BK	FUSED IGNITION SWITCH OUPUT (RUN-ACC)
87	F30 18RD/DB	FUSED IGNITION SWITCH OUTPUT (RUN-ACC)

**COURTESY
LAMP
RELAY**

CAVITY	CIRCUIT	FUNCTION
30	INTERNAL	COURTESY LAMP RELAY OUTPUT
85	M112 20BR/LG	COURTESY LAMP RELAY CONTROL
86	INTERNAL	FUSED B(+)
87	INTERNAL	GROUND

**FOG
LAMP
RELAY**

CAVITY	CIRCUIT	FUNCTION
30	INTERNAL	FUSED B(+)
85	L95 20DG/YL	FOG LAMP RELAY CONTROL
86	INTERNAL	FUSED B(+)
87	INTERNAL	FOG LAMP RELAY OUTPUT

**PARK
LAMP
RELAY**

CAVITY	CIRCUIT	FUNCTION
30	INTERNAL	FUSED B(+)
85	L79 20TN	PARK LAMP RELAY CONTROL
86	INTERNAL	FUSED B(+)
87	INTERNAL	PARK LAMP RELAY OUTPUT

**POWER
ANTENNA
RELAY
(BUILT-UP
-EXPORT)**

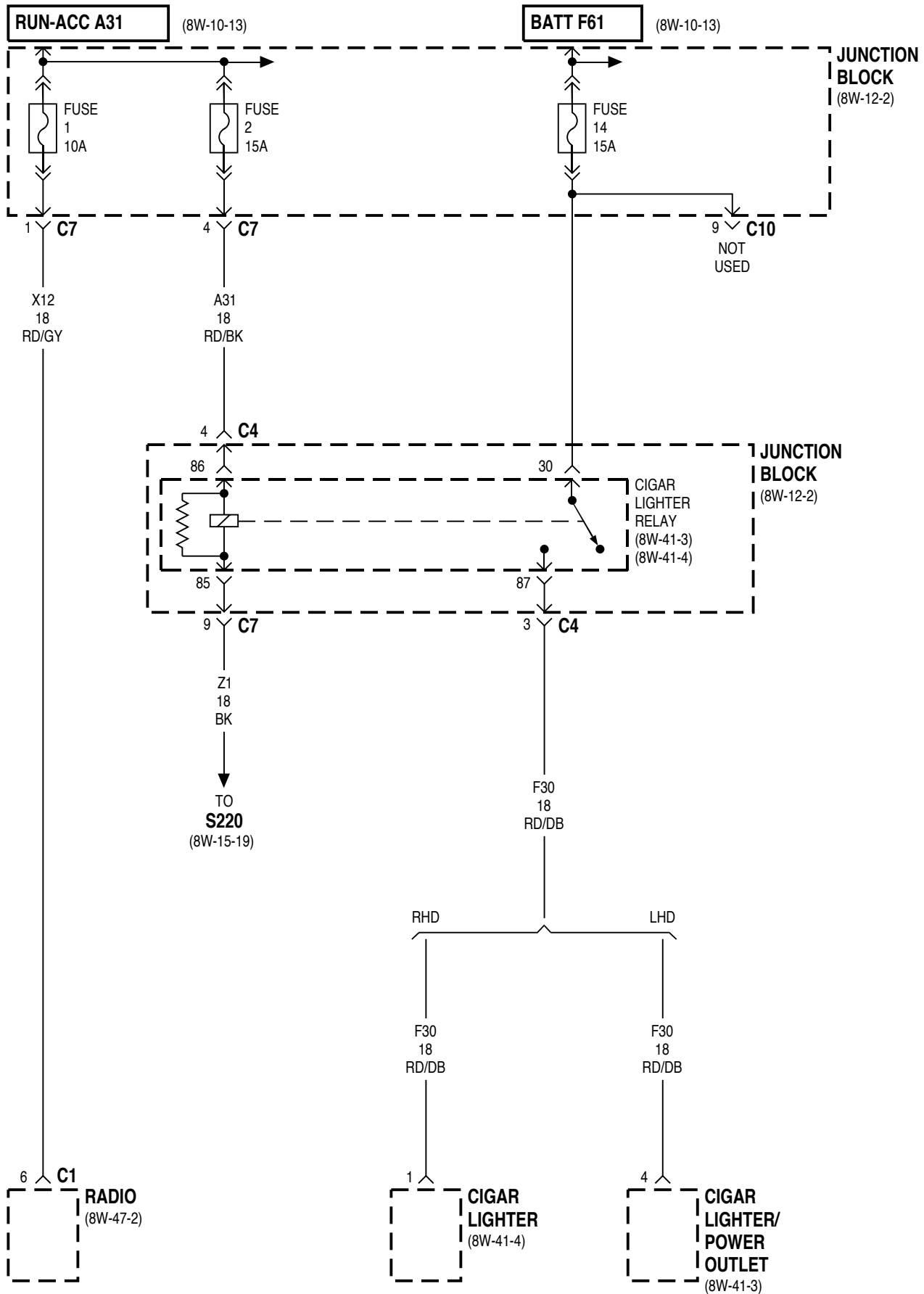
CAVITY	CIRCUIT	FUNCTION
1	INTERNAL	FUSED B(+)
2	INTERNAL	GROUND
3	INTERNAL	RADIO 12 VOLT OUTPUT
4	X16 20GY	POWER ANTENNA DRIVER
5	X14 20WT	POWER ANTENNA DOWN CONTROL
6	X17 20DG	POWER ANTENNA UP CONTROL

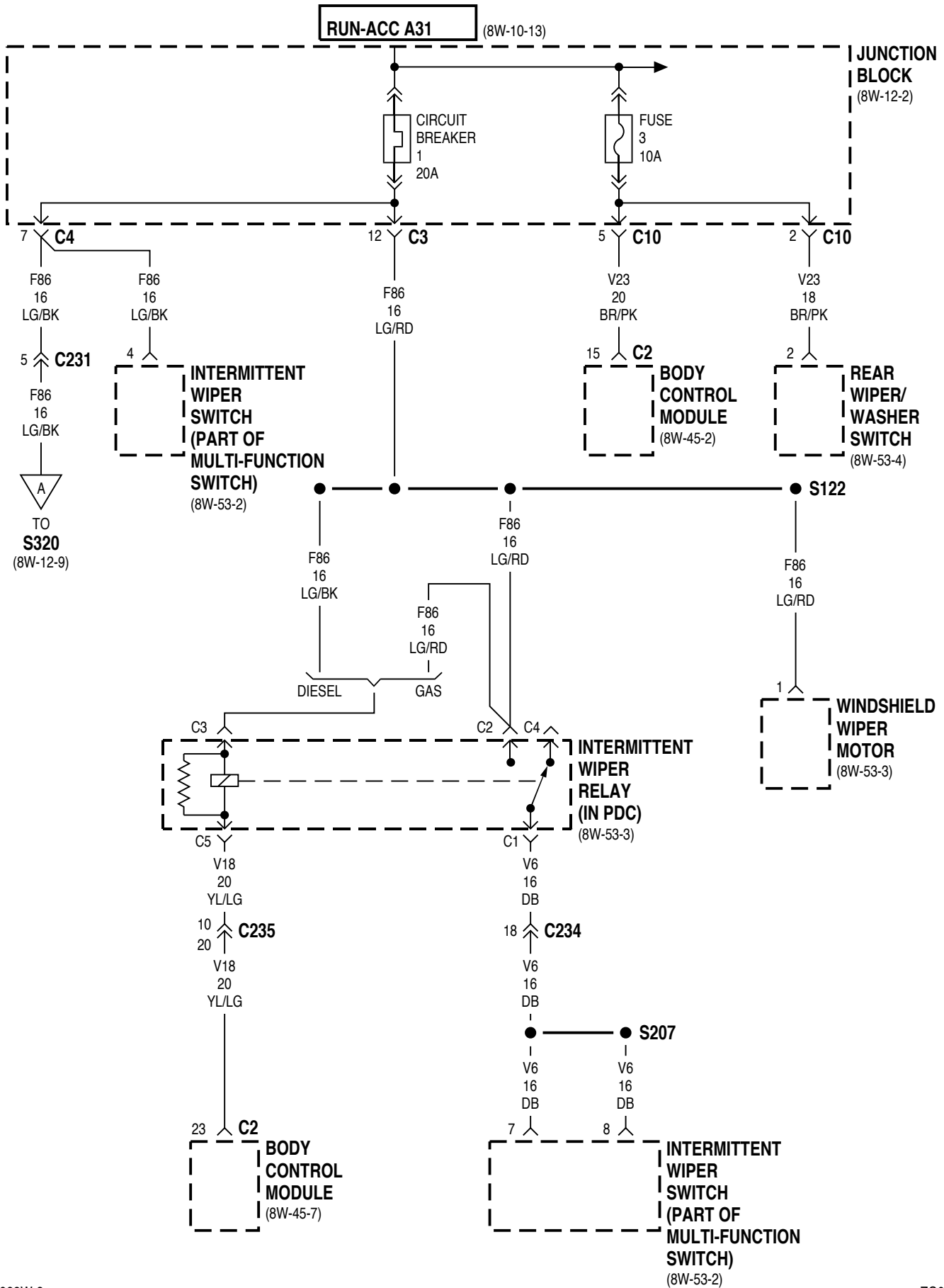
**REAR
FOG LAMP
RELAY
(BUILT-UP
-EXPORT)**

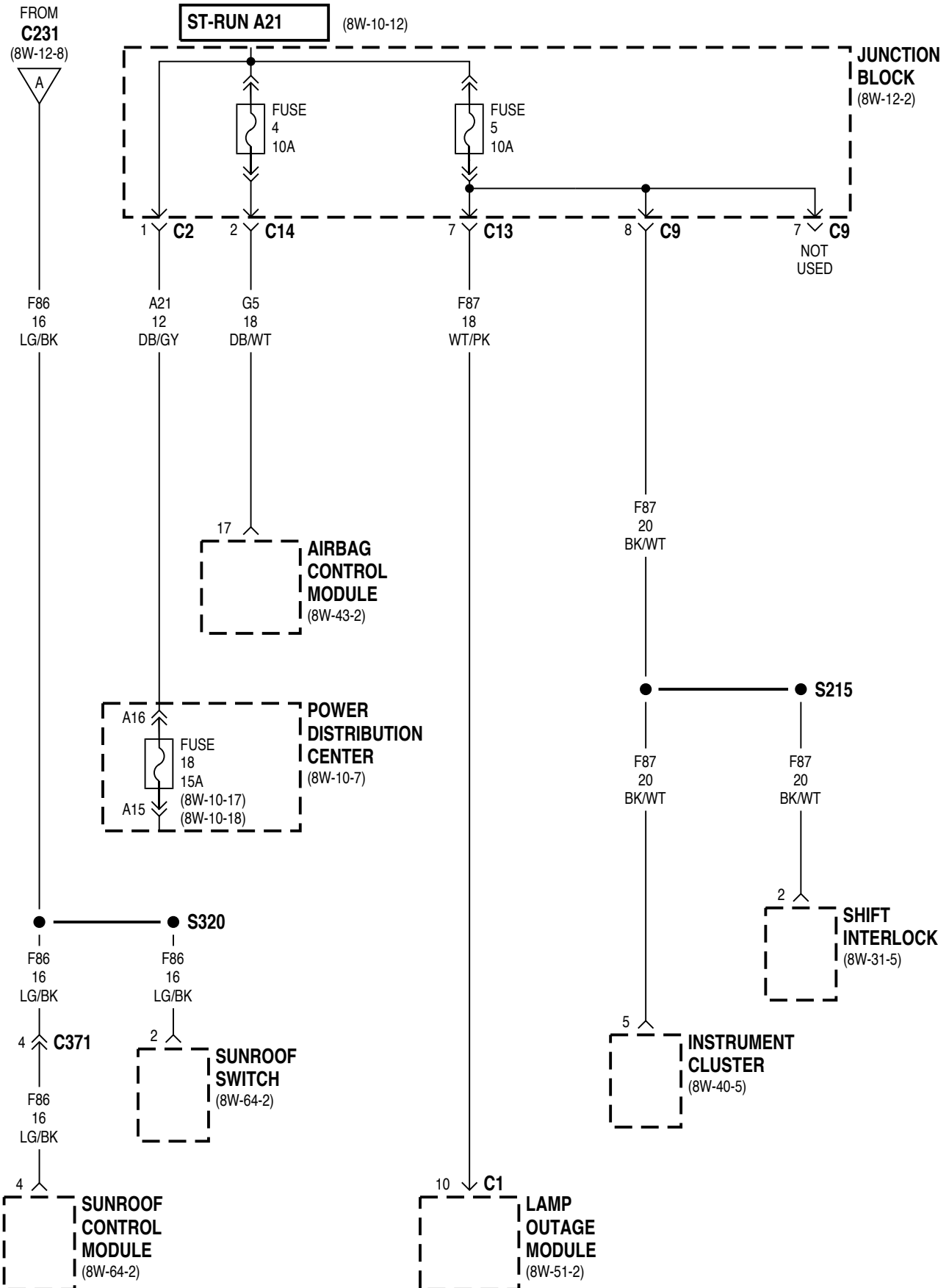
CAVITY	CIRCUIT	FUNCTION
30	INTERNAL	FUSED B(+)
85	L96 20LG/RD	REAR FOG LAMP RELAY CONTROL
86	L95 18DG/YL	FUSED B(+)
87	L36 18LG	REAR FOG LAMP RELAY OUTPUT

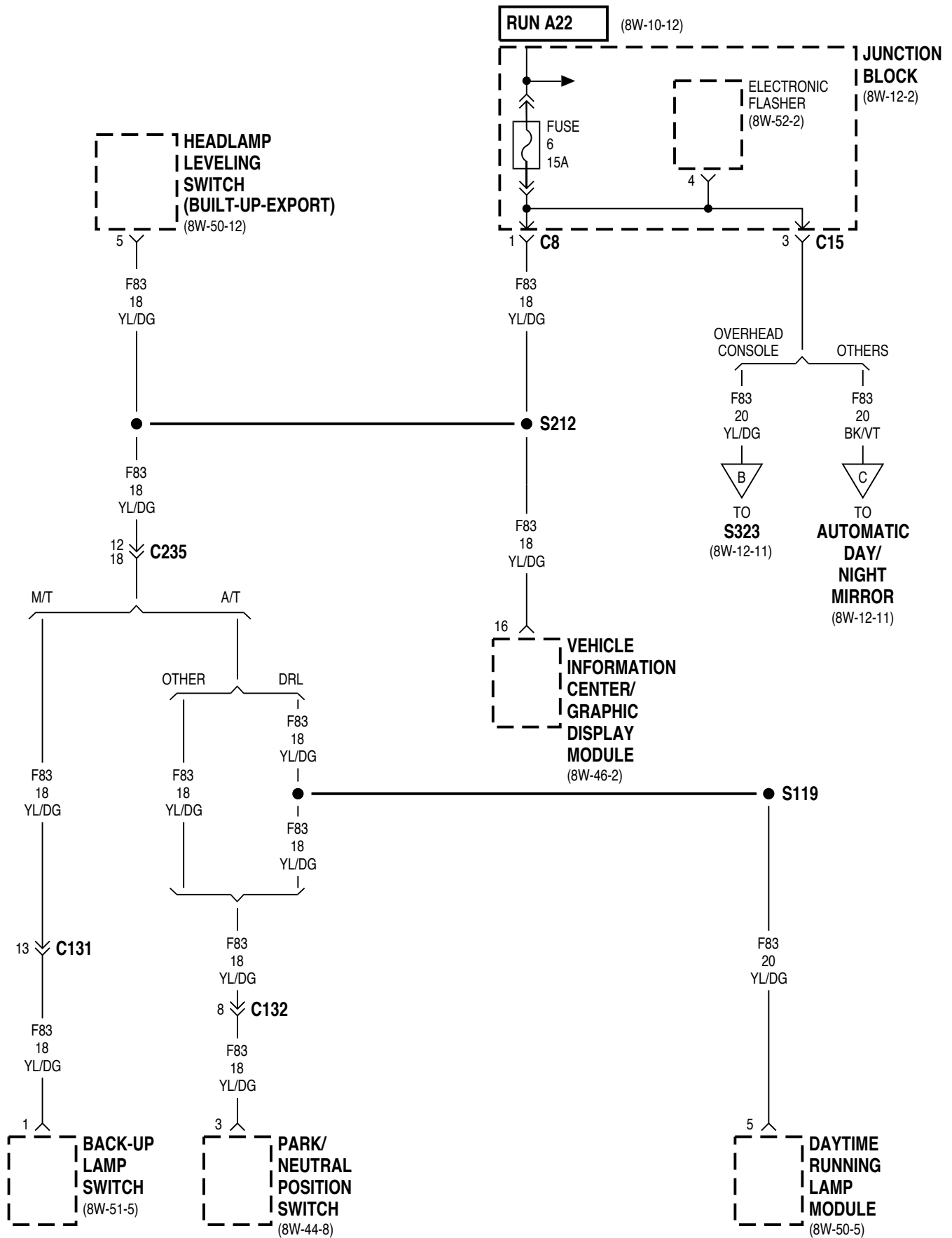
**REAR
WINDOW
DEFOGGER
RELAY**

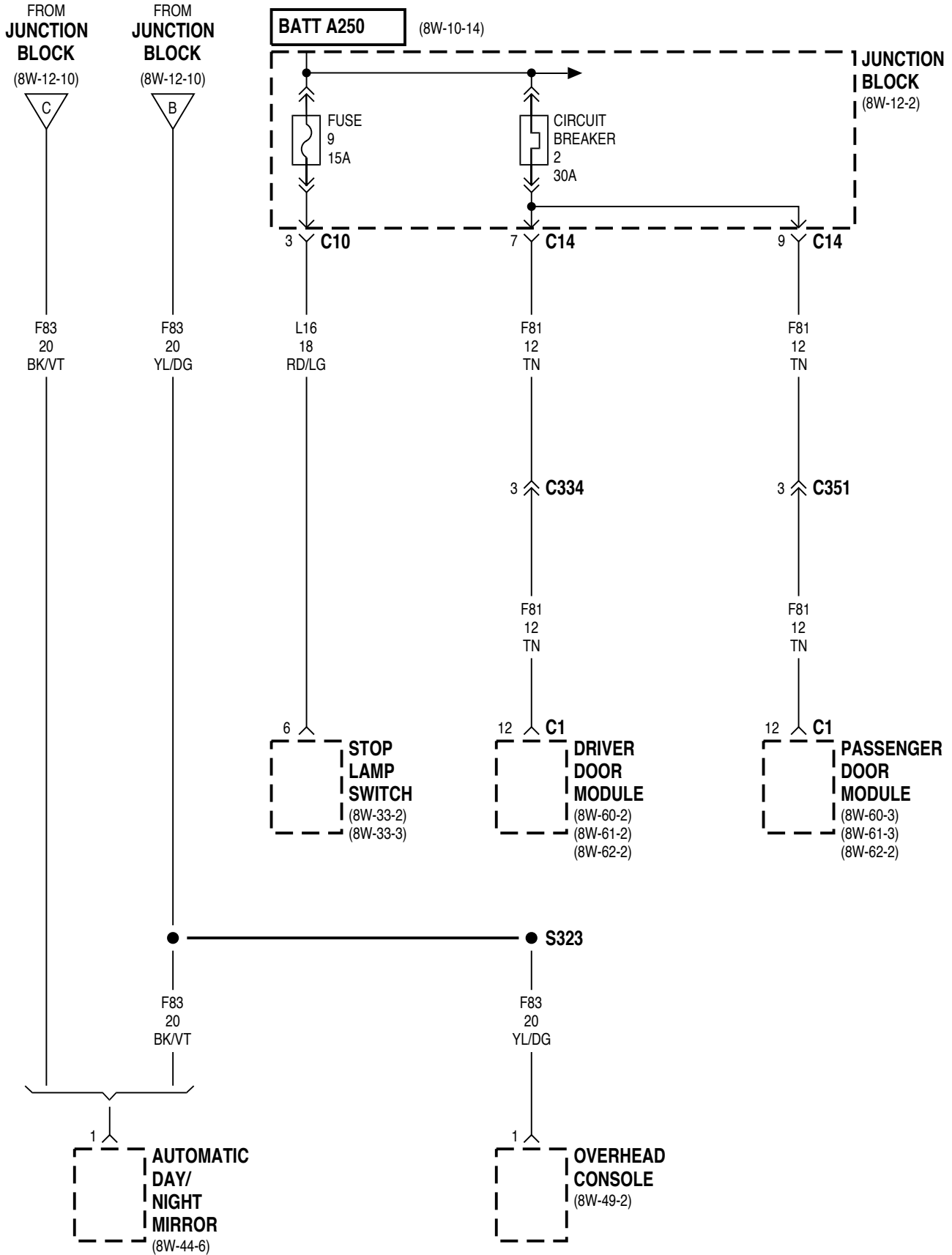
CAVITY	CIRCUIT	FUNCTION
30	INTERNAL	FUSED B(+)
85	C14 20WT/RD	REAR WINDOW DEFOGGER RELAY CONTROL
86	INTERNAL	FUSED B(+)
87	INTERNAL	REAR WINDOW DEFOGGER RELAY OUTPUT

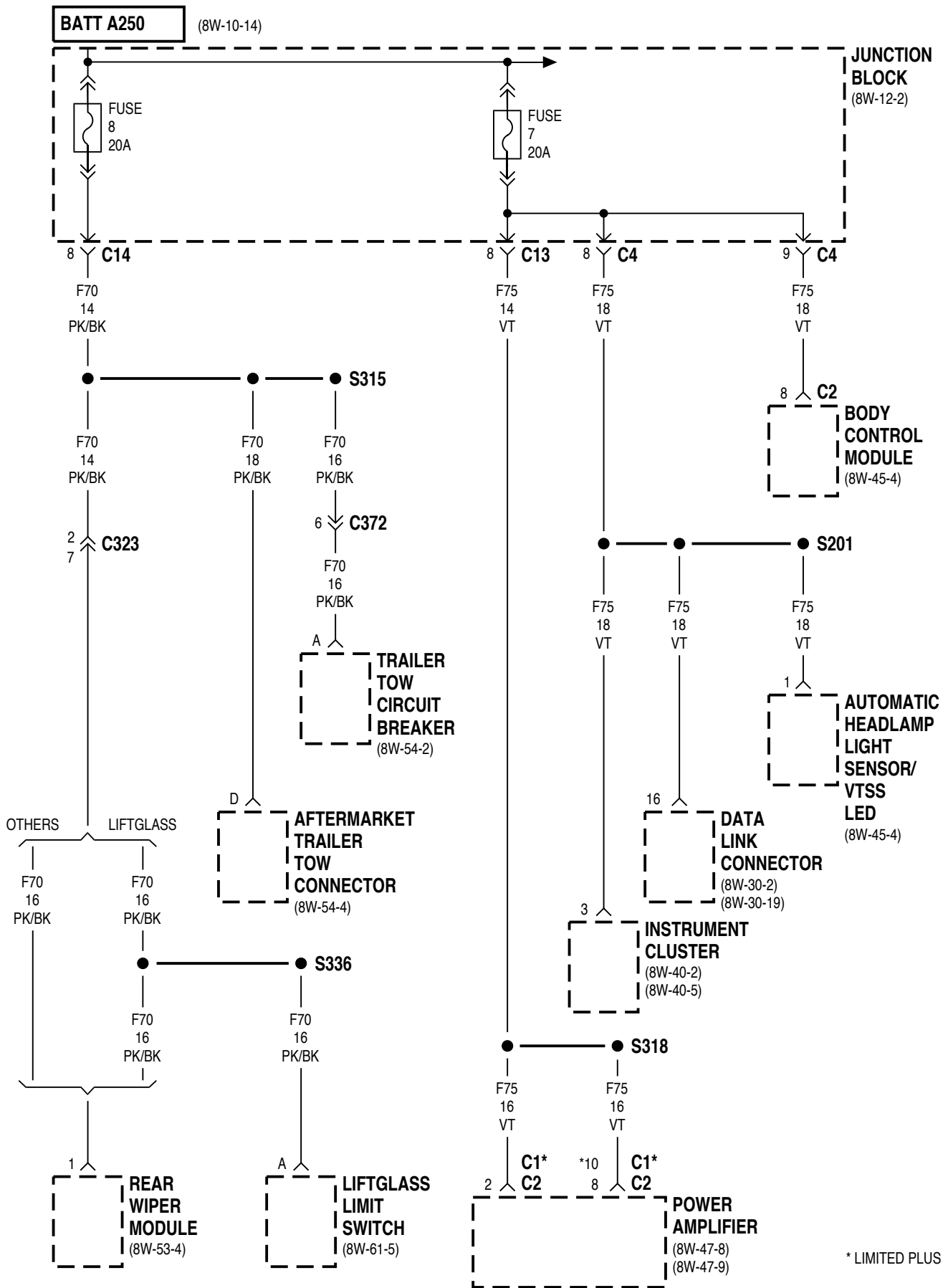




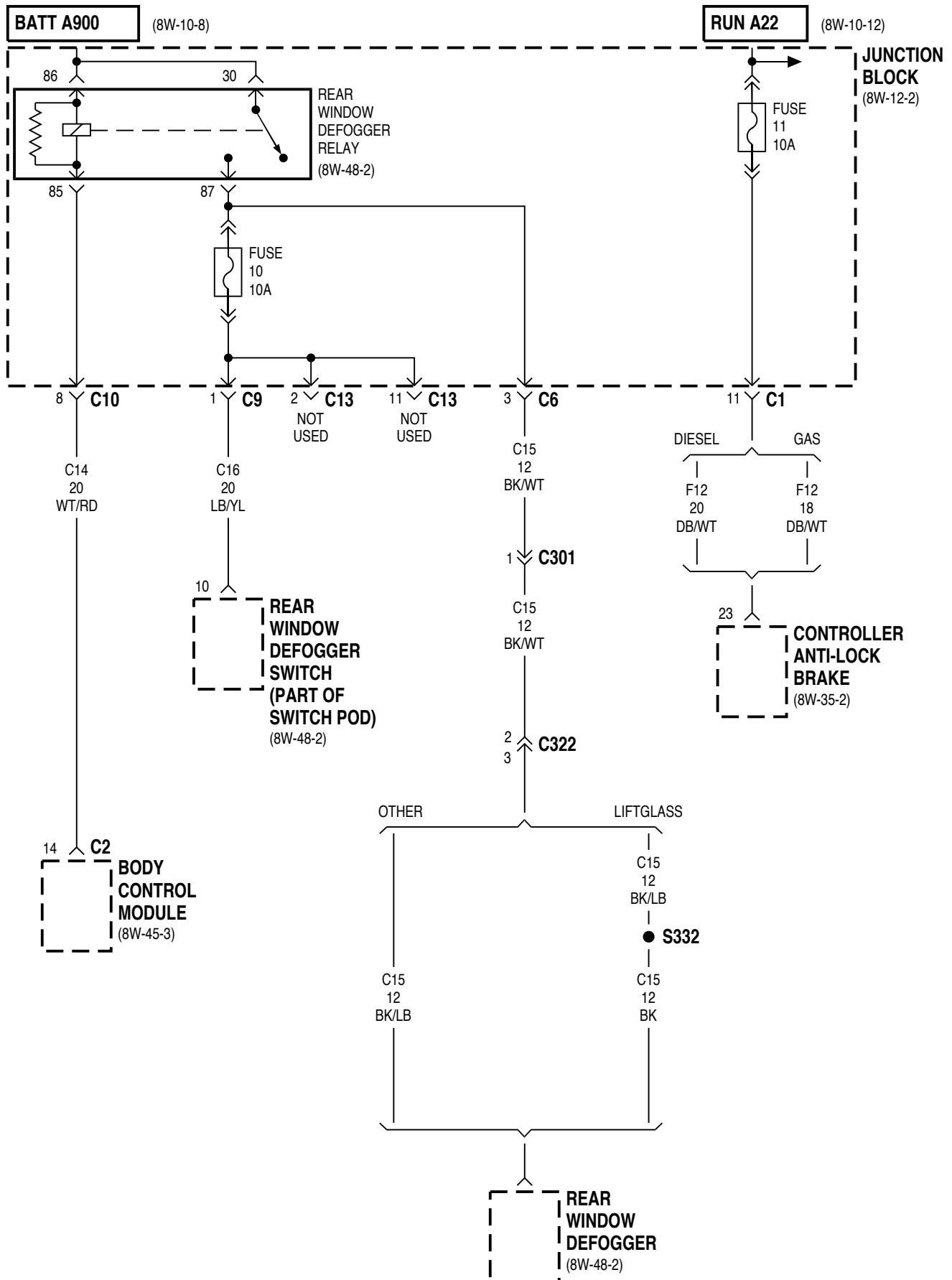


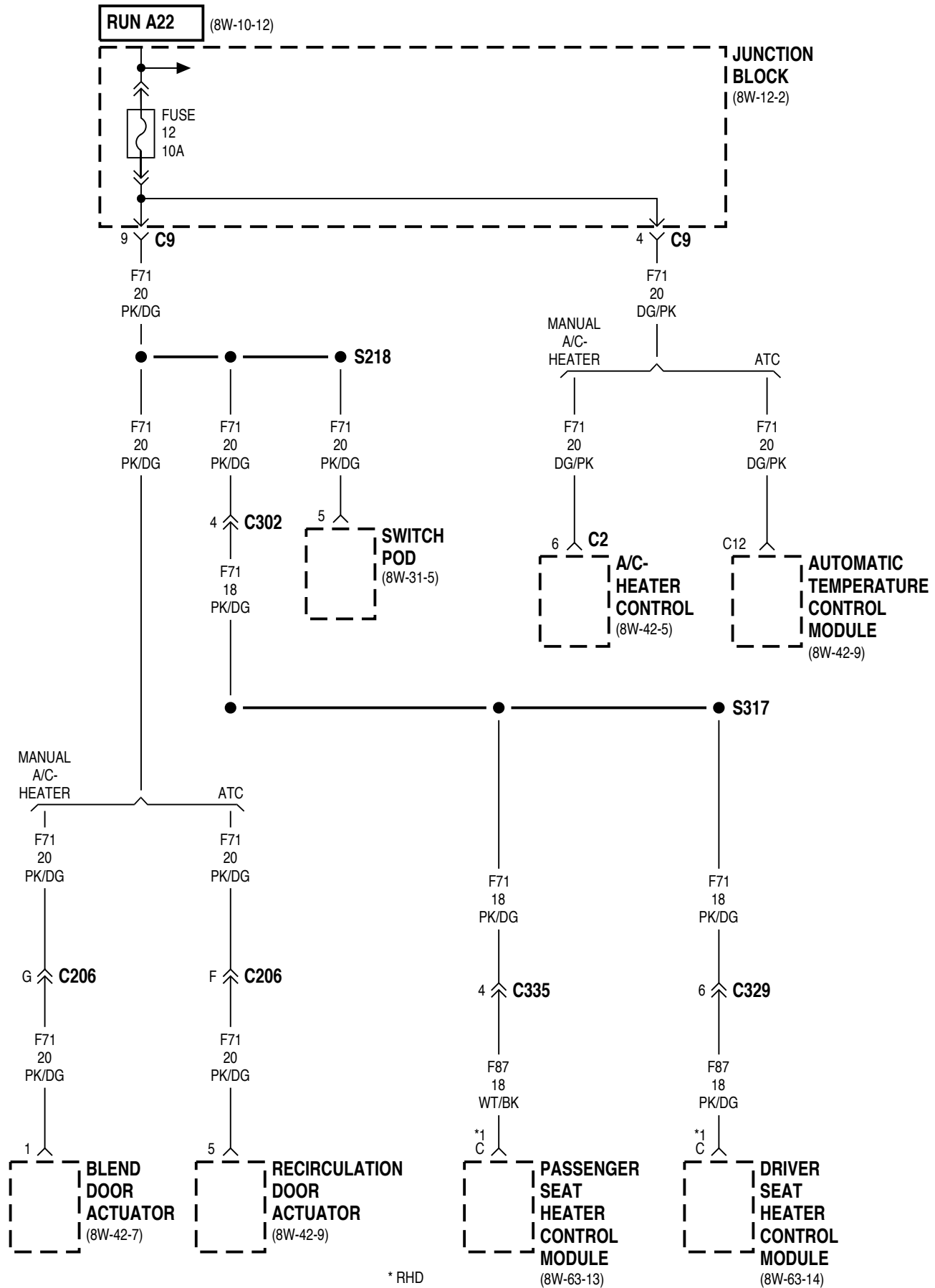


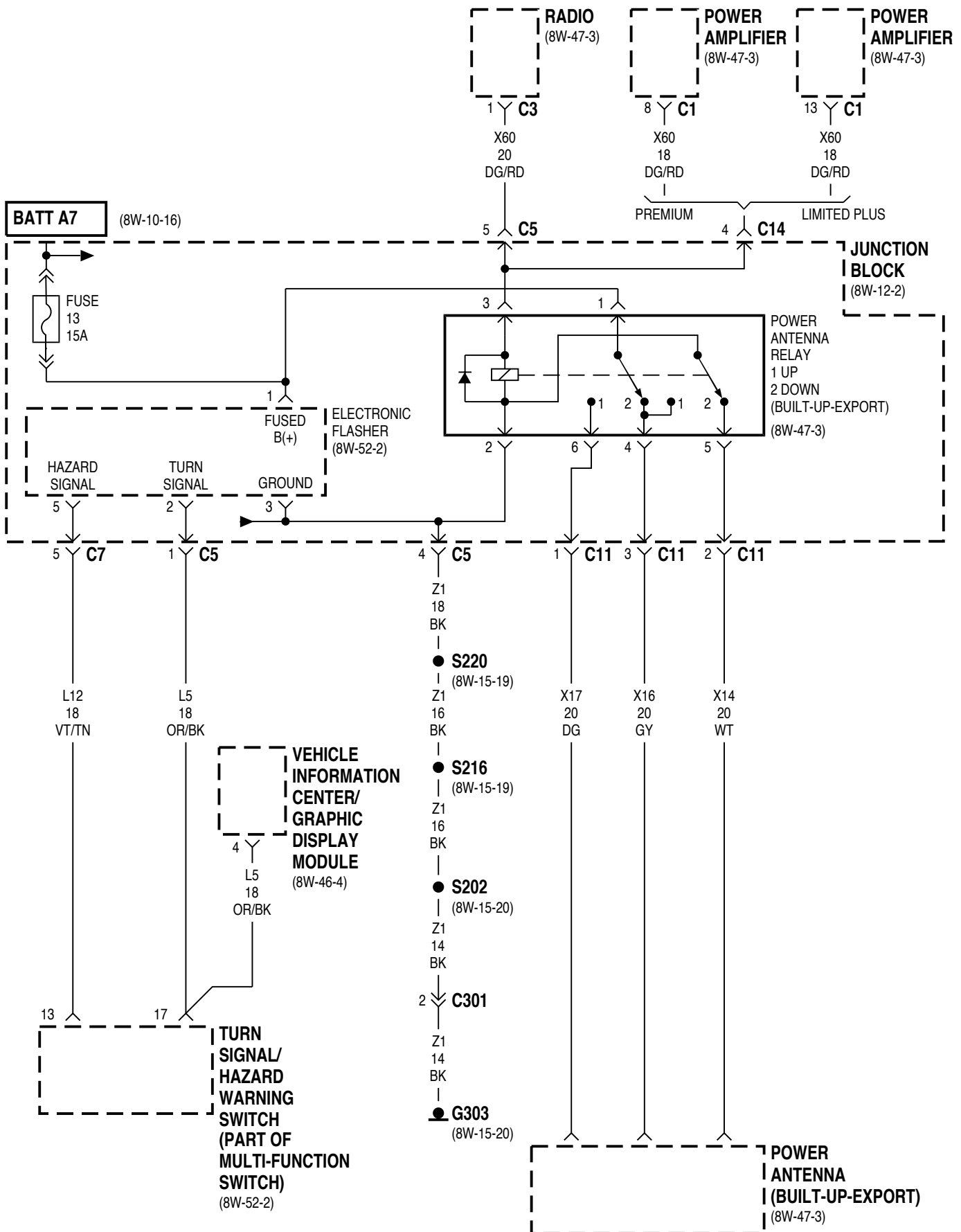


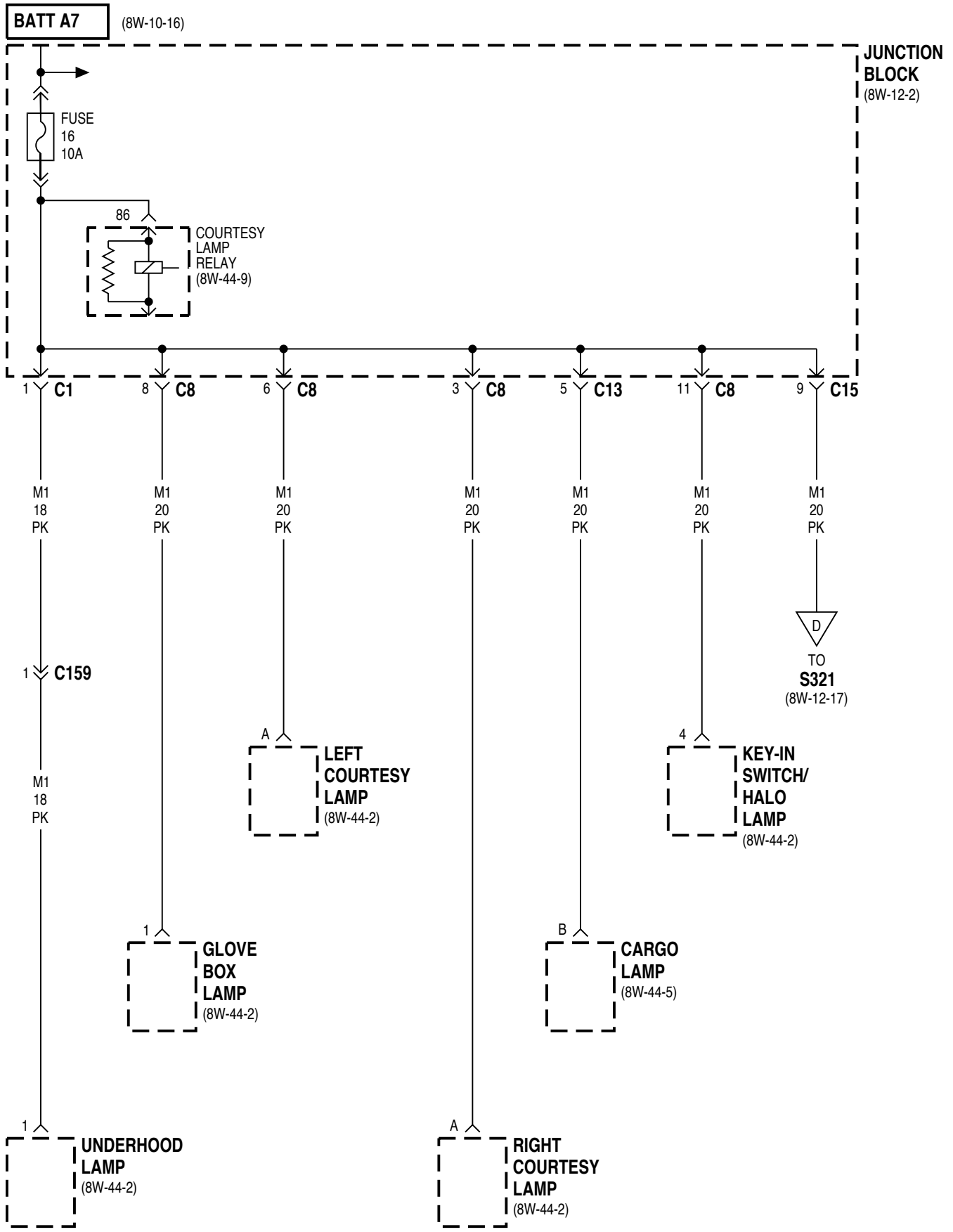


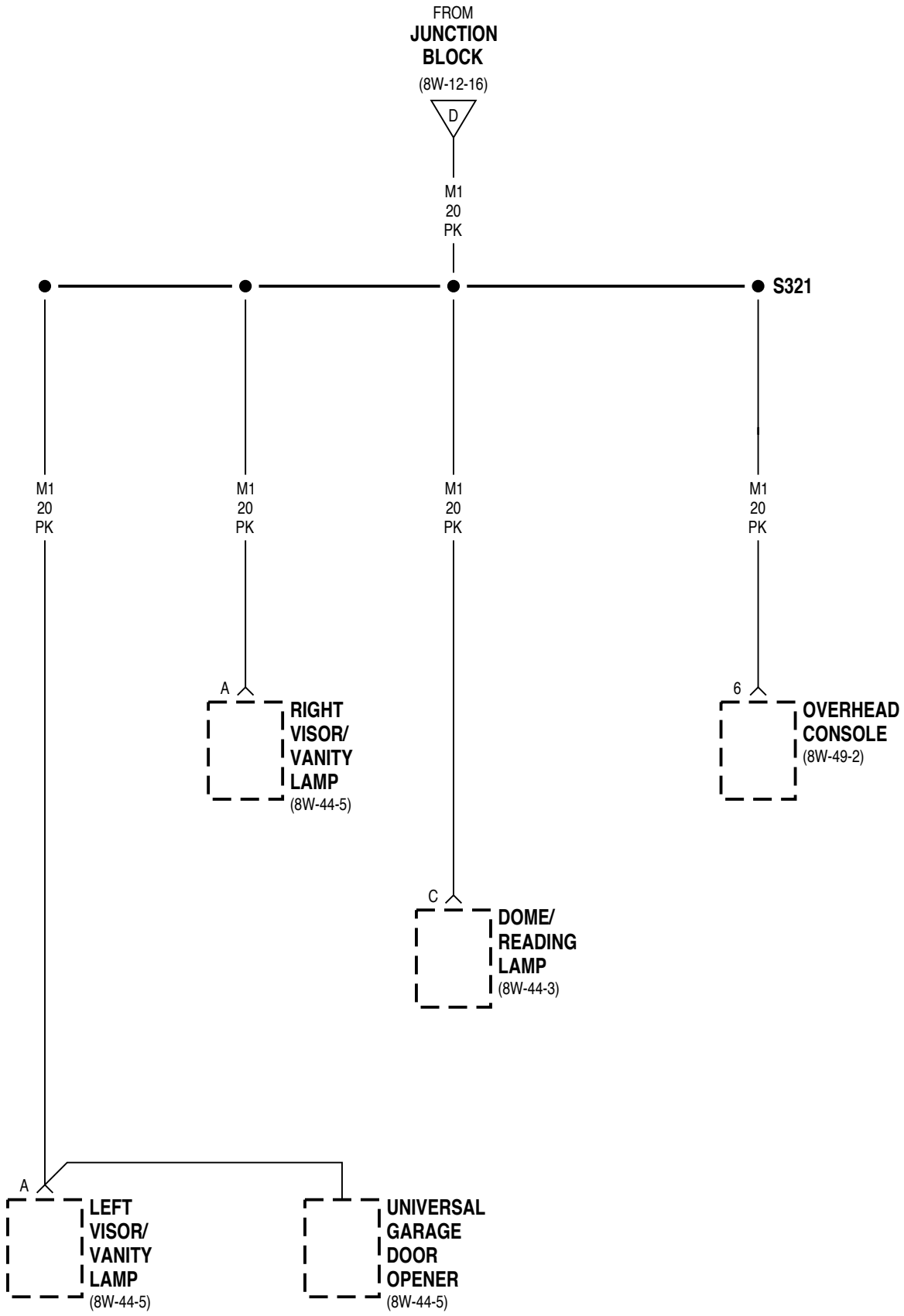
* LIMITED PLUS

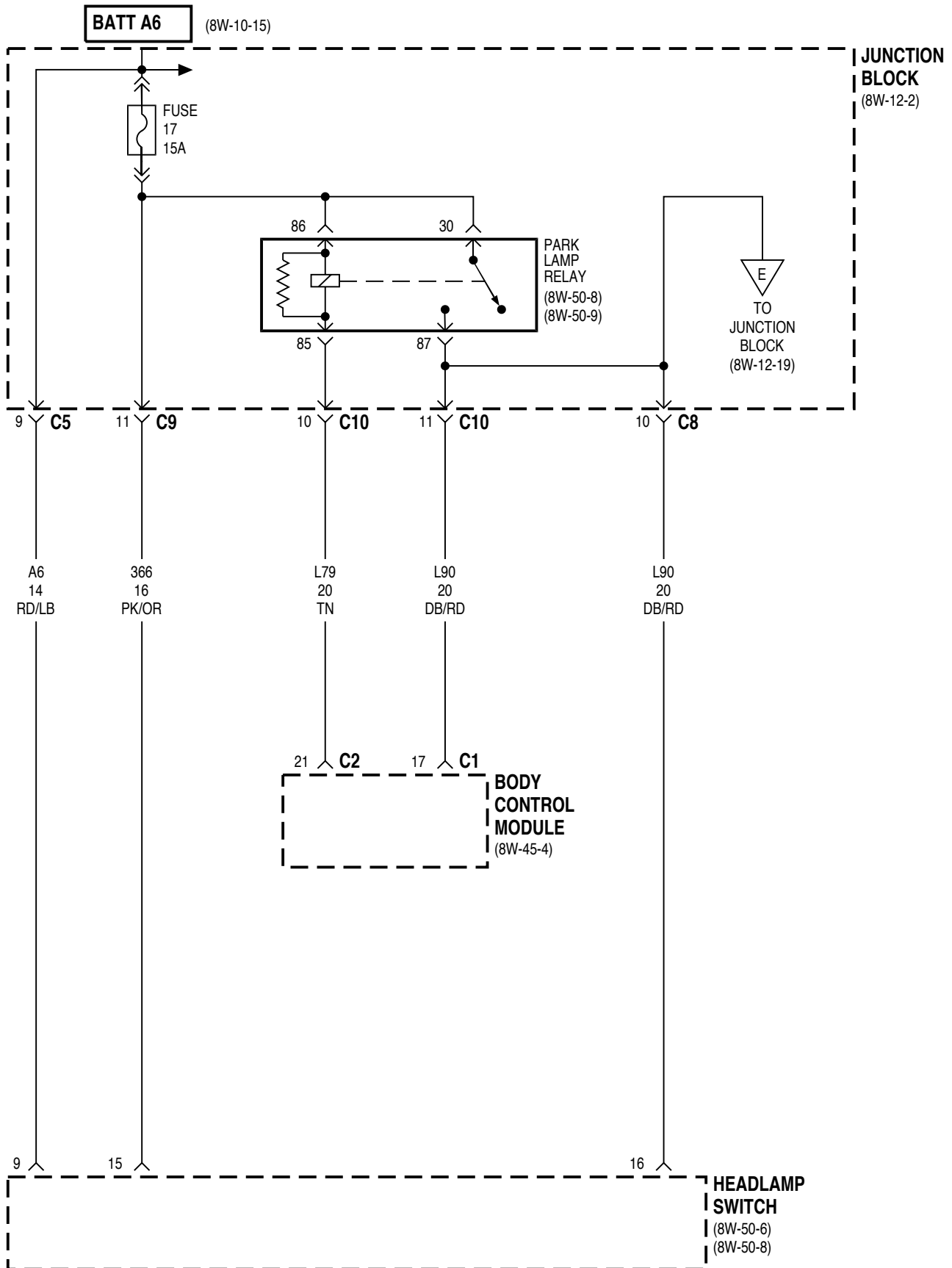


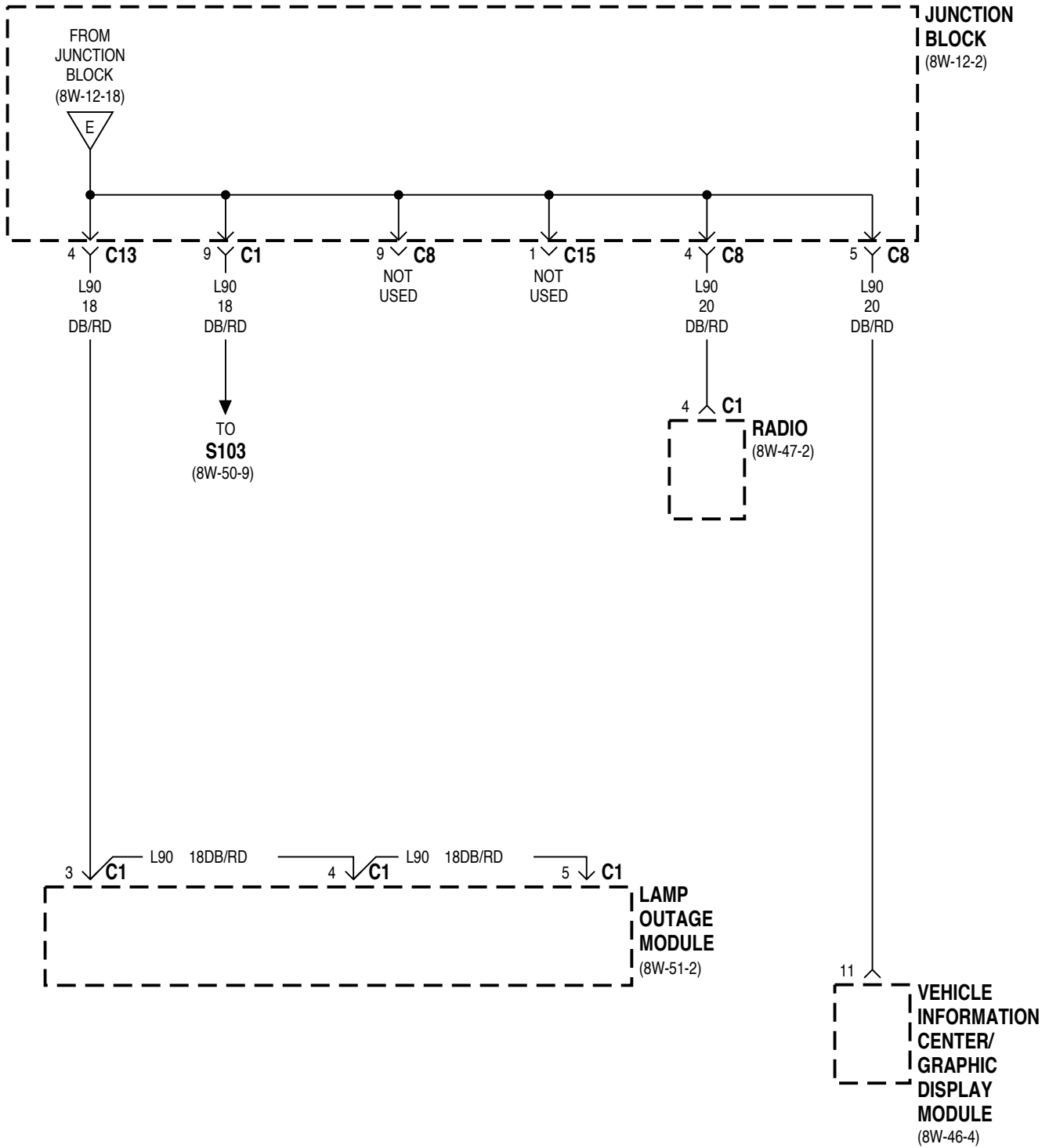


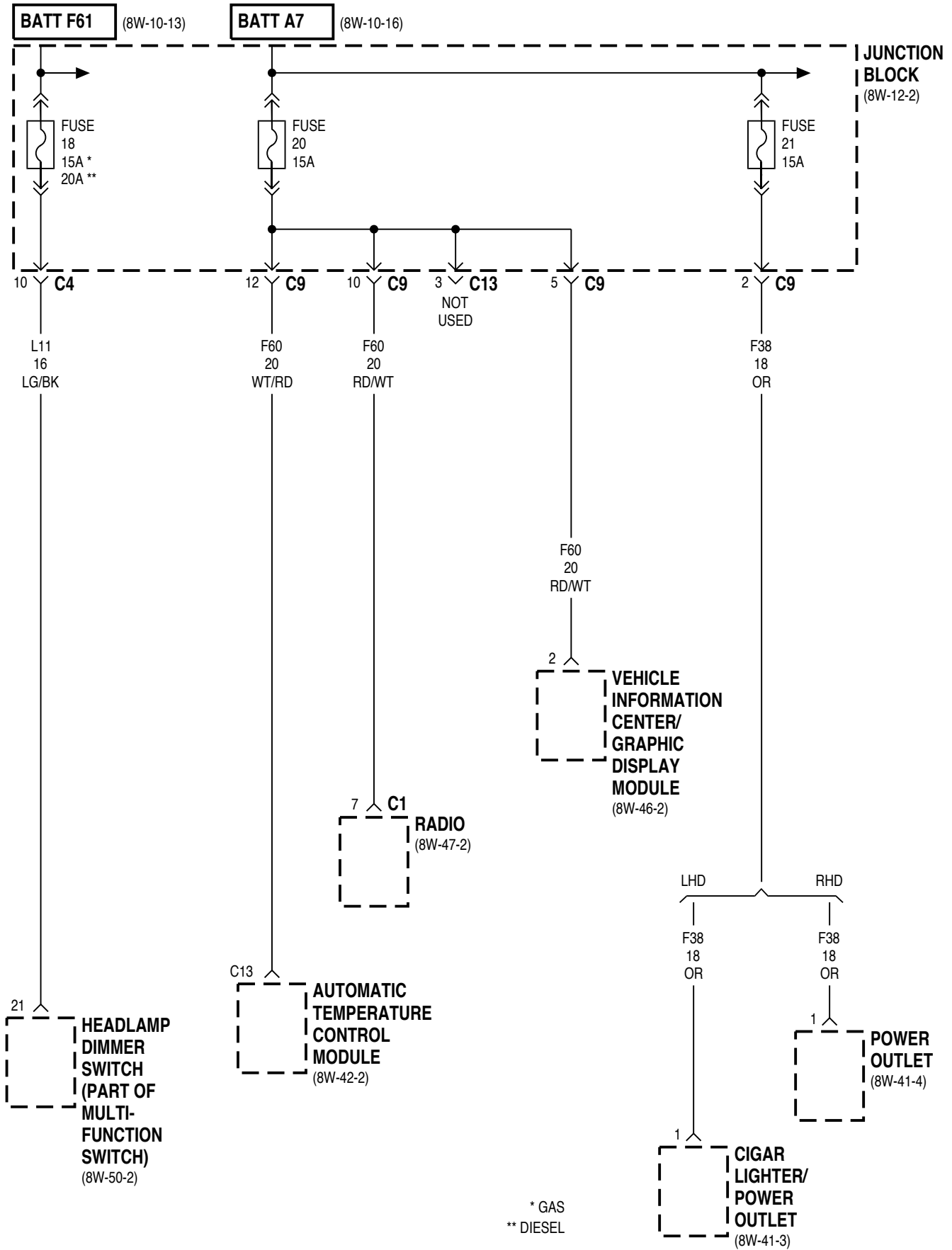




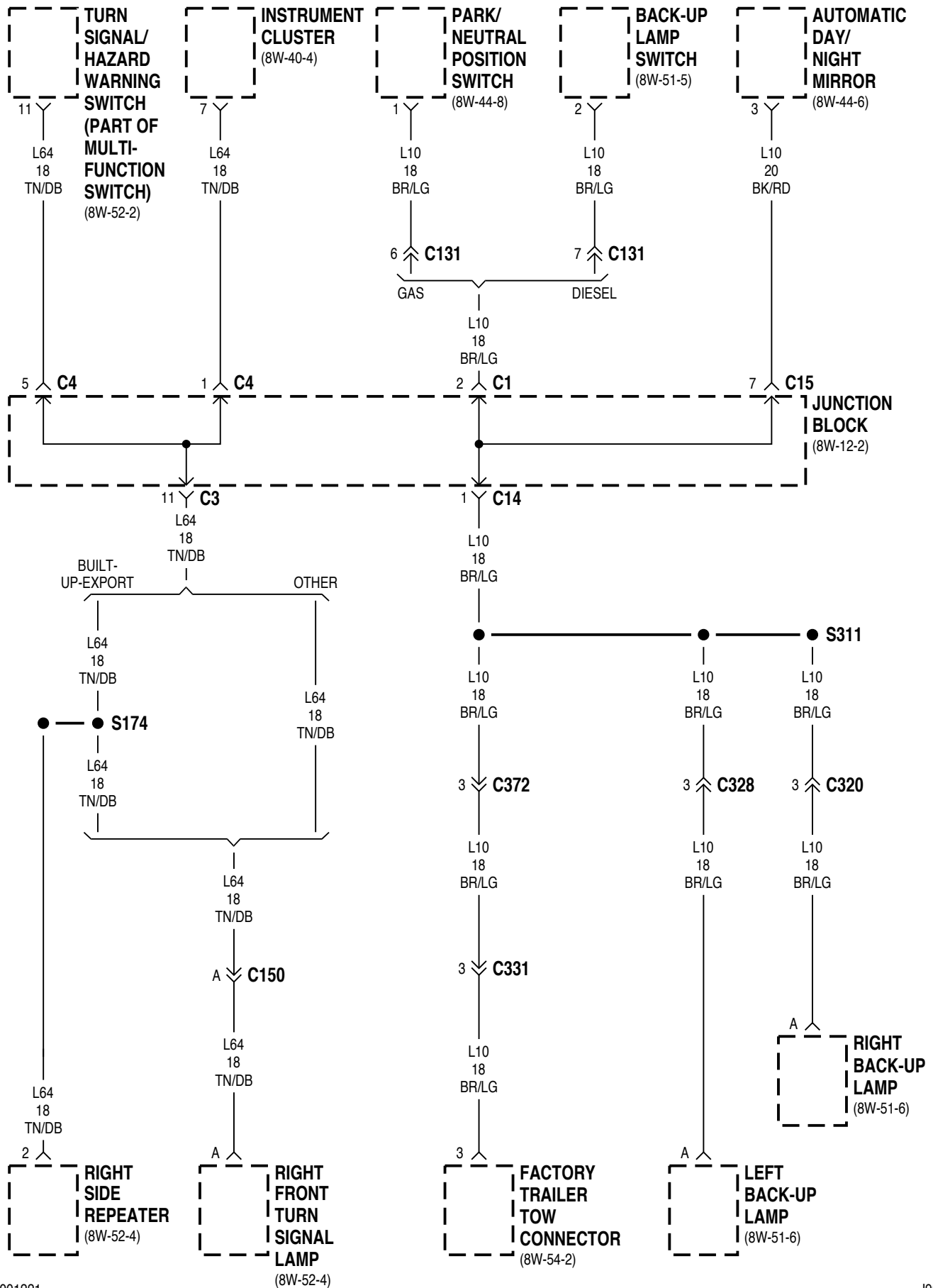


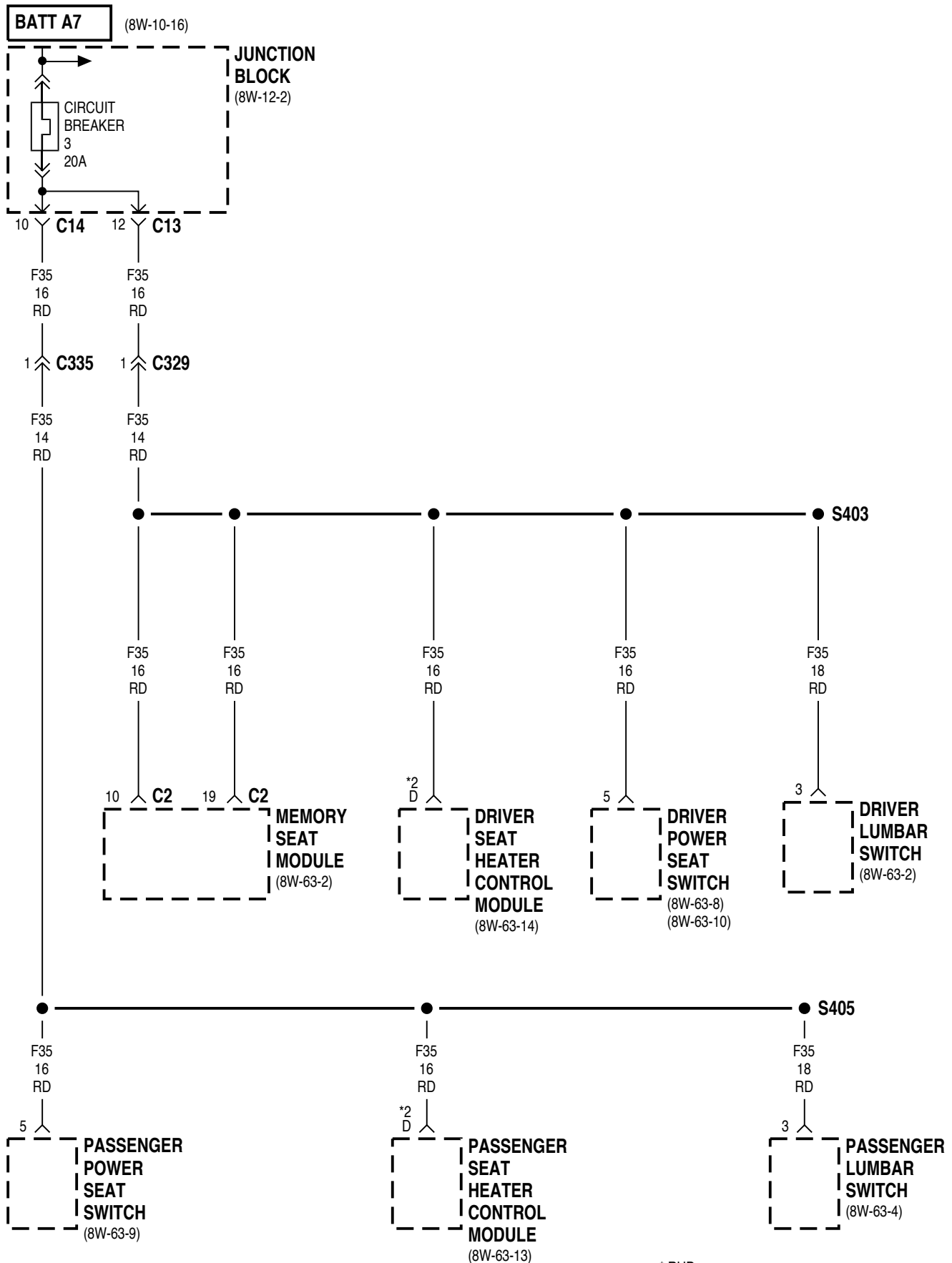


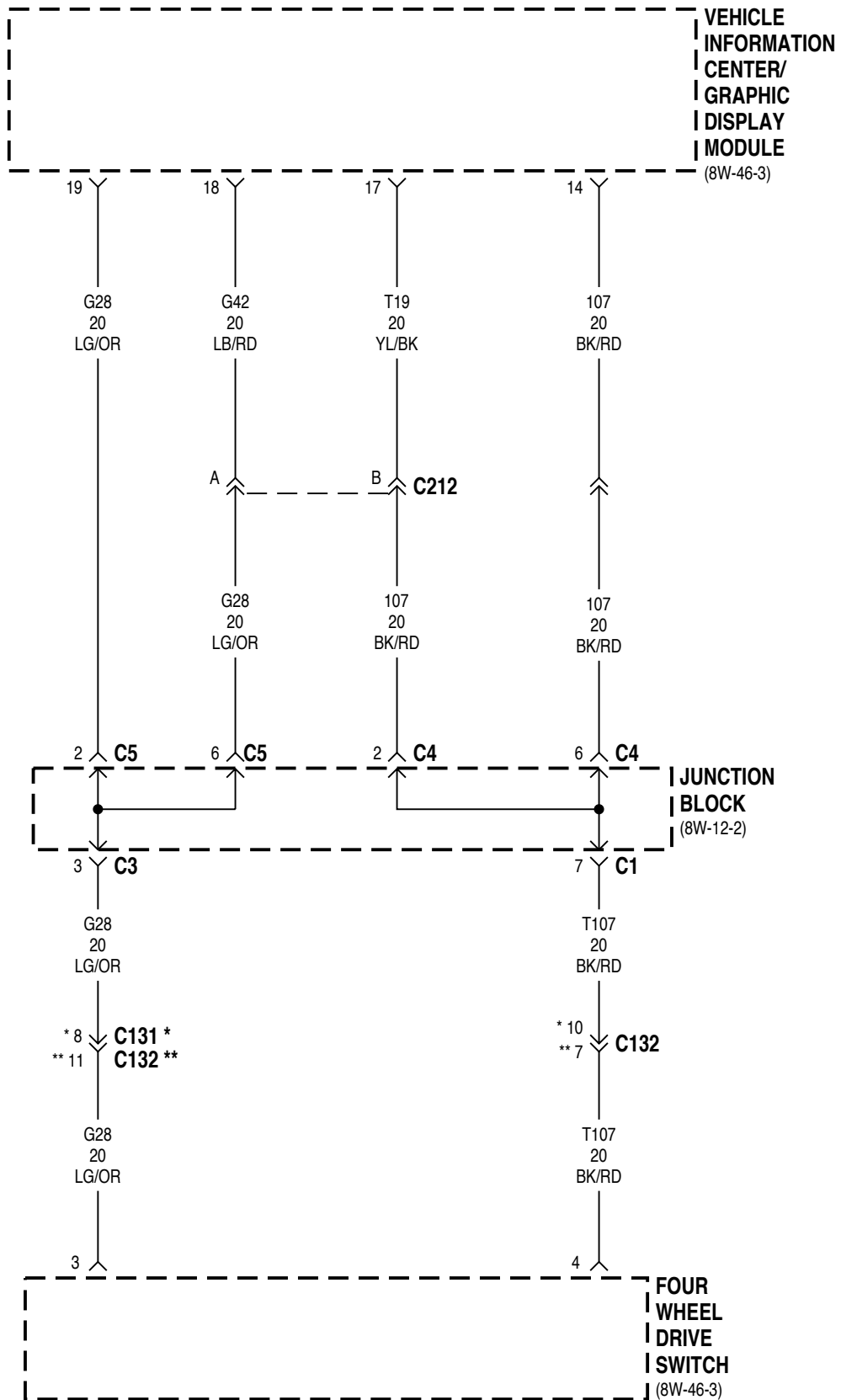


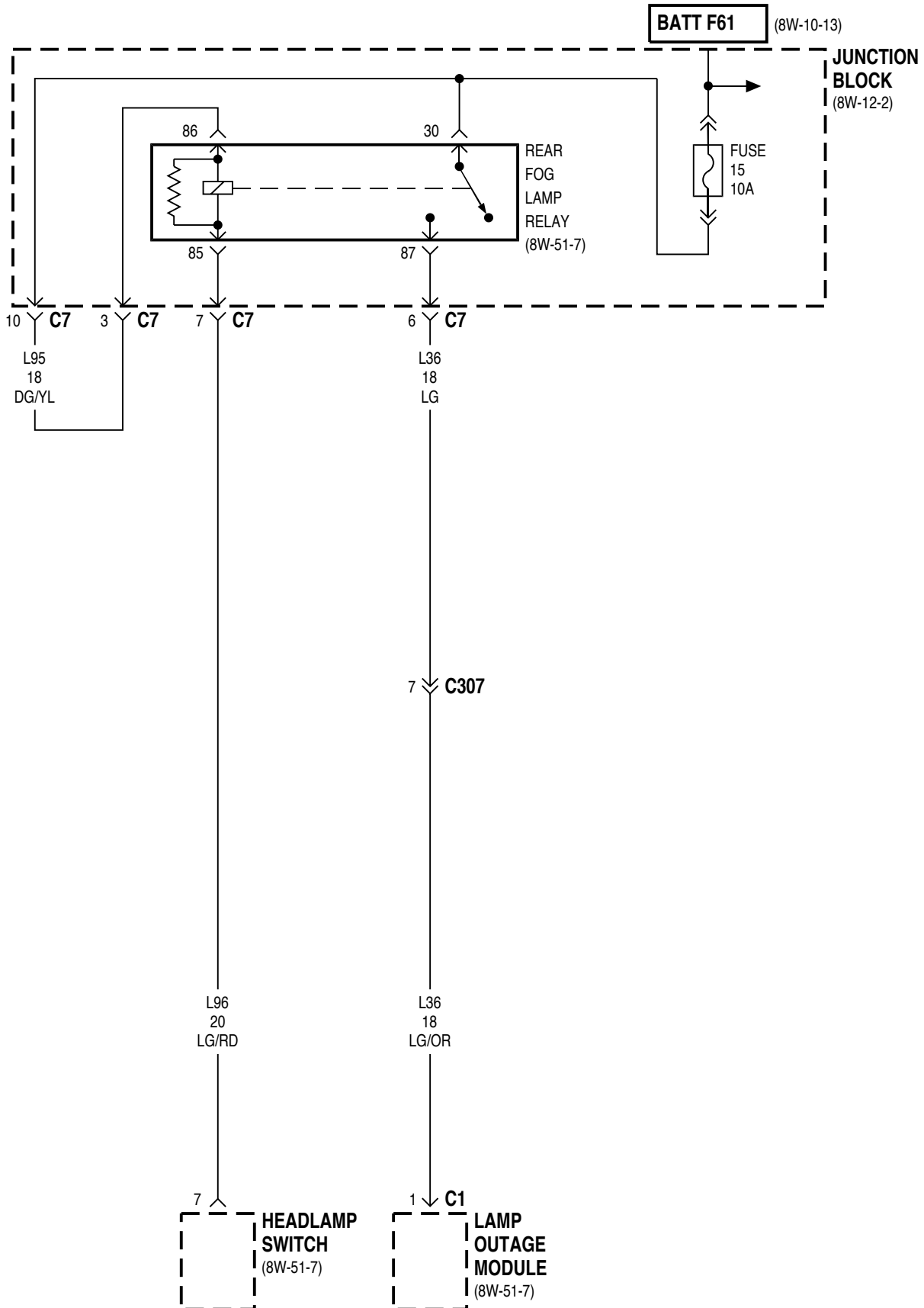


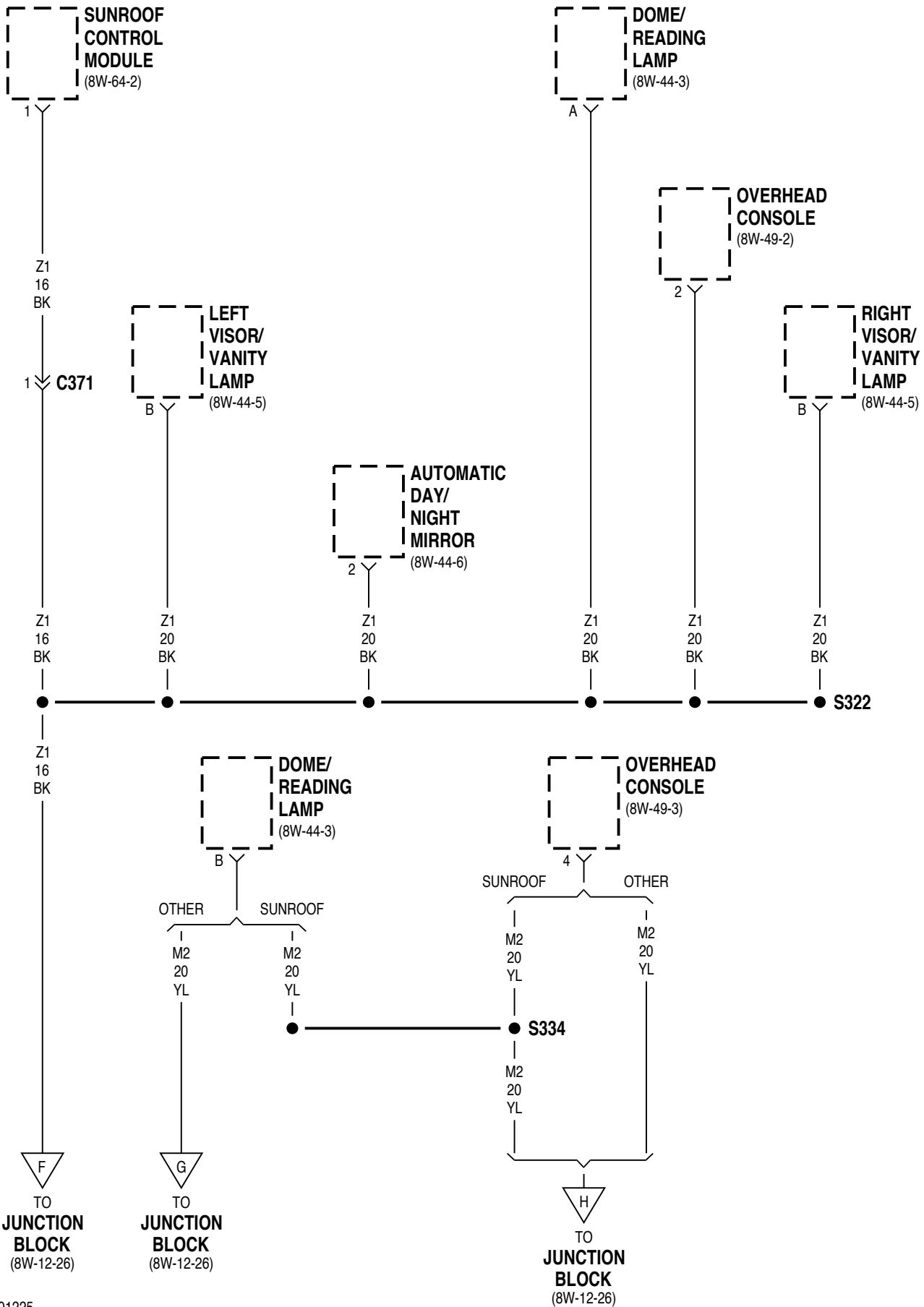
* GAS
** DIESEL

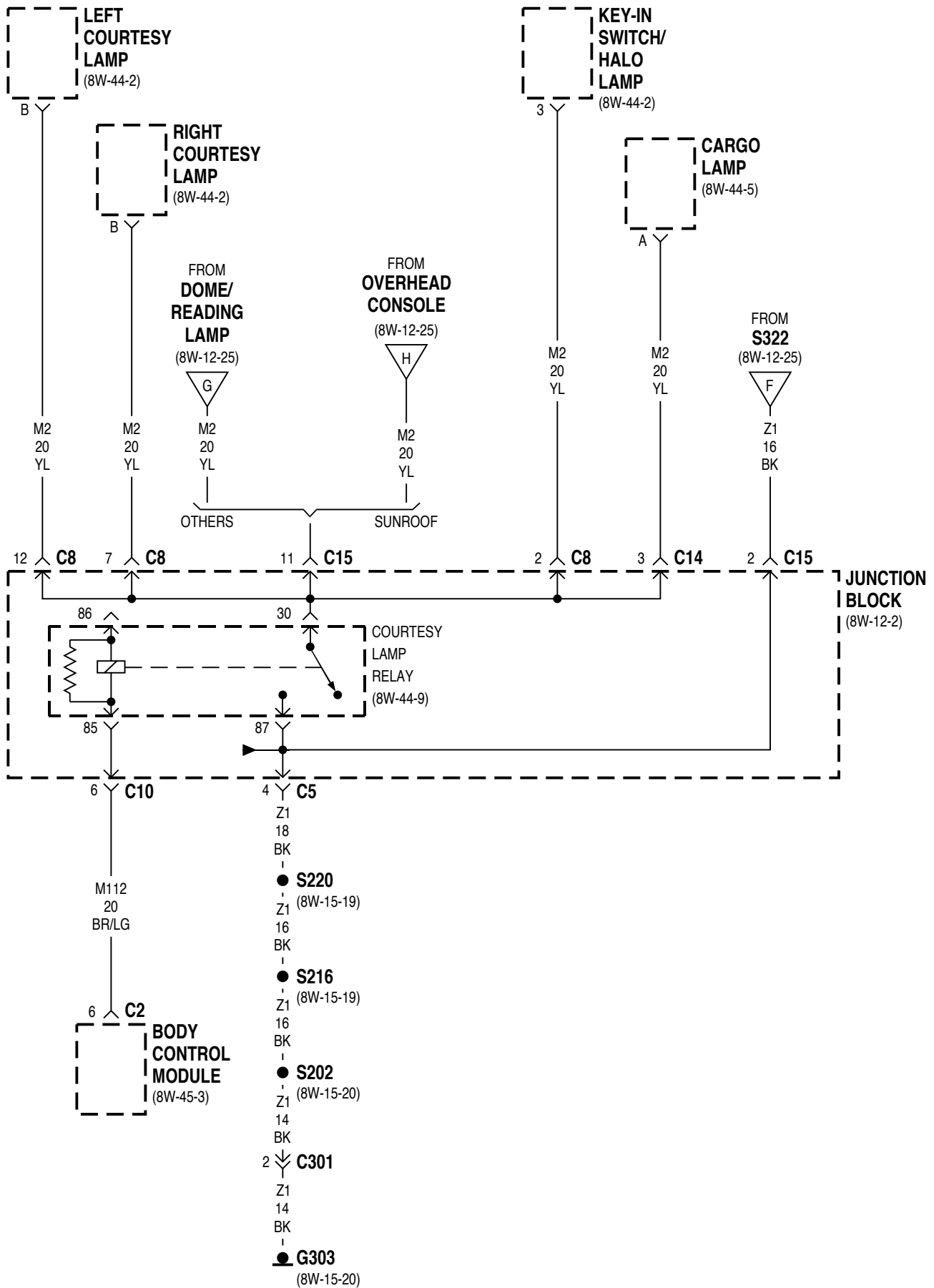


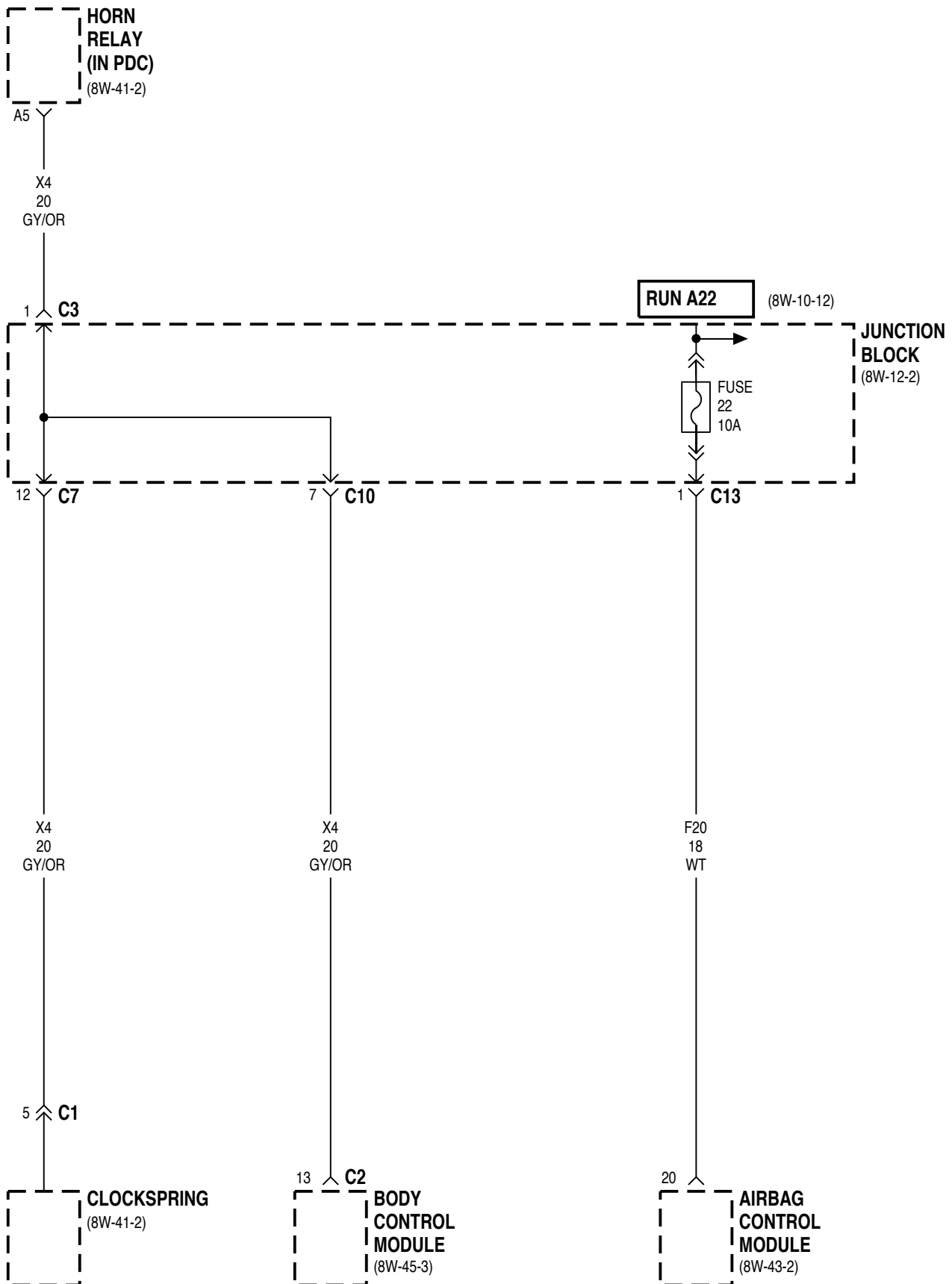


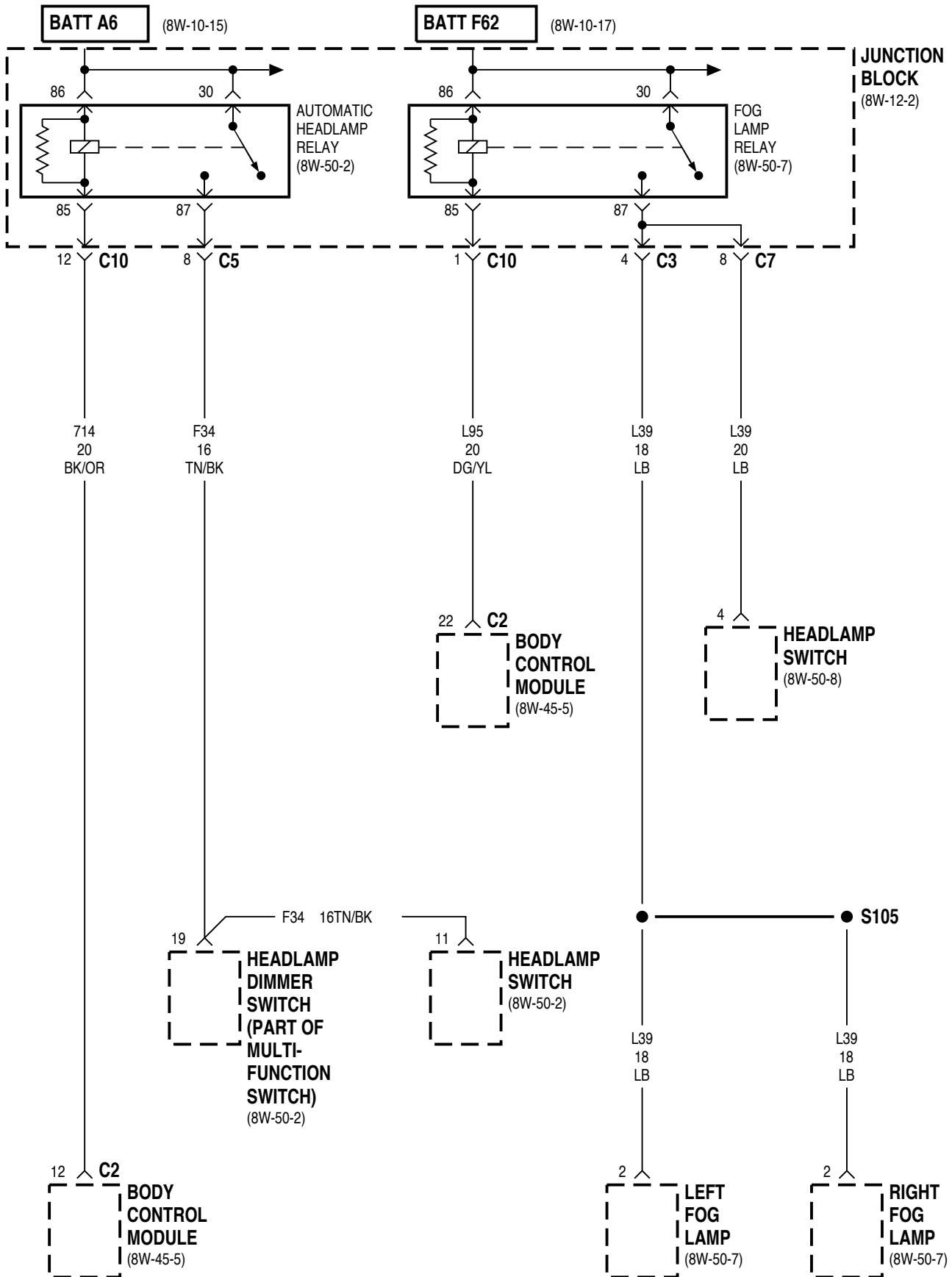






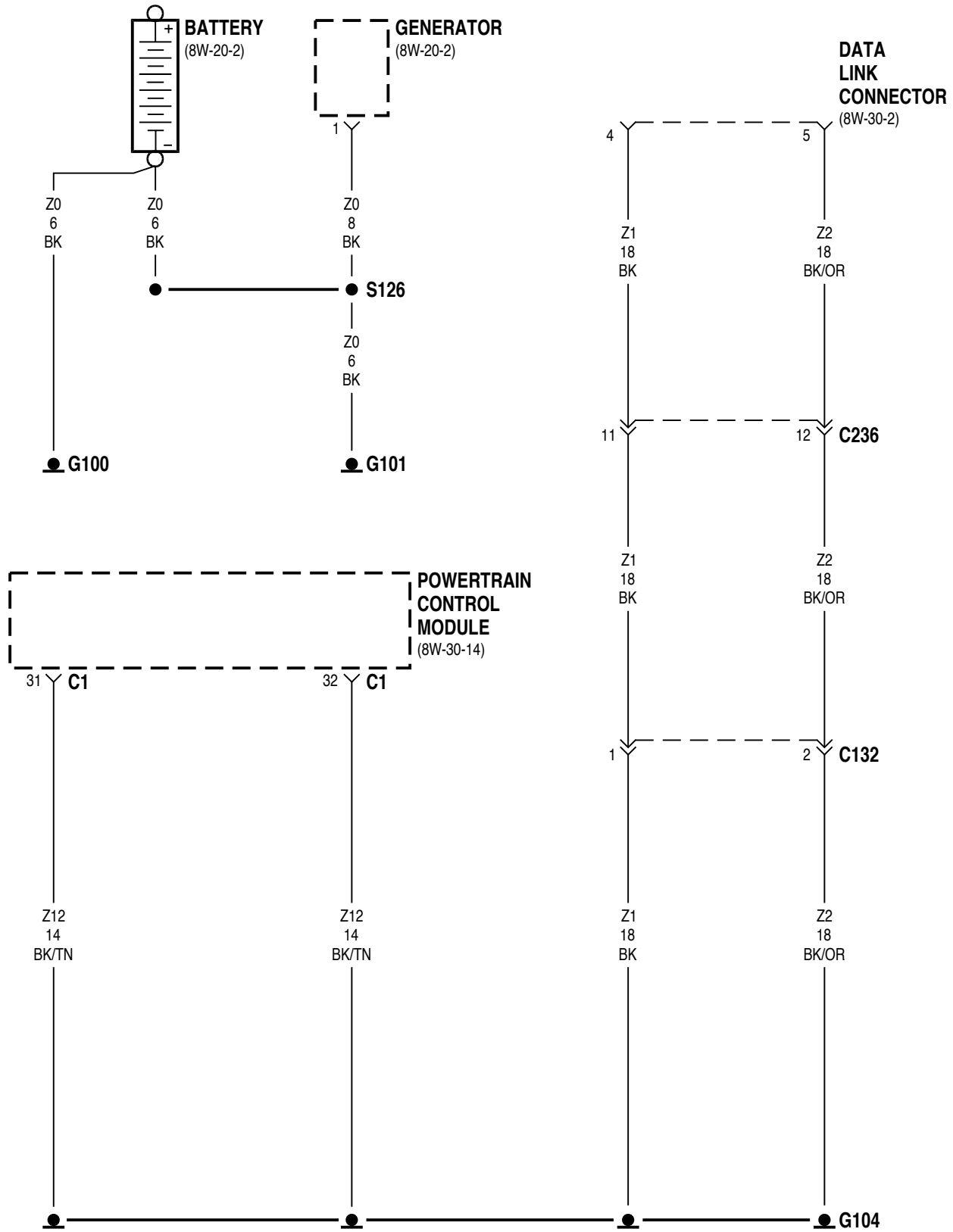


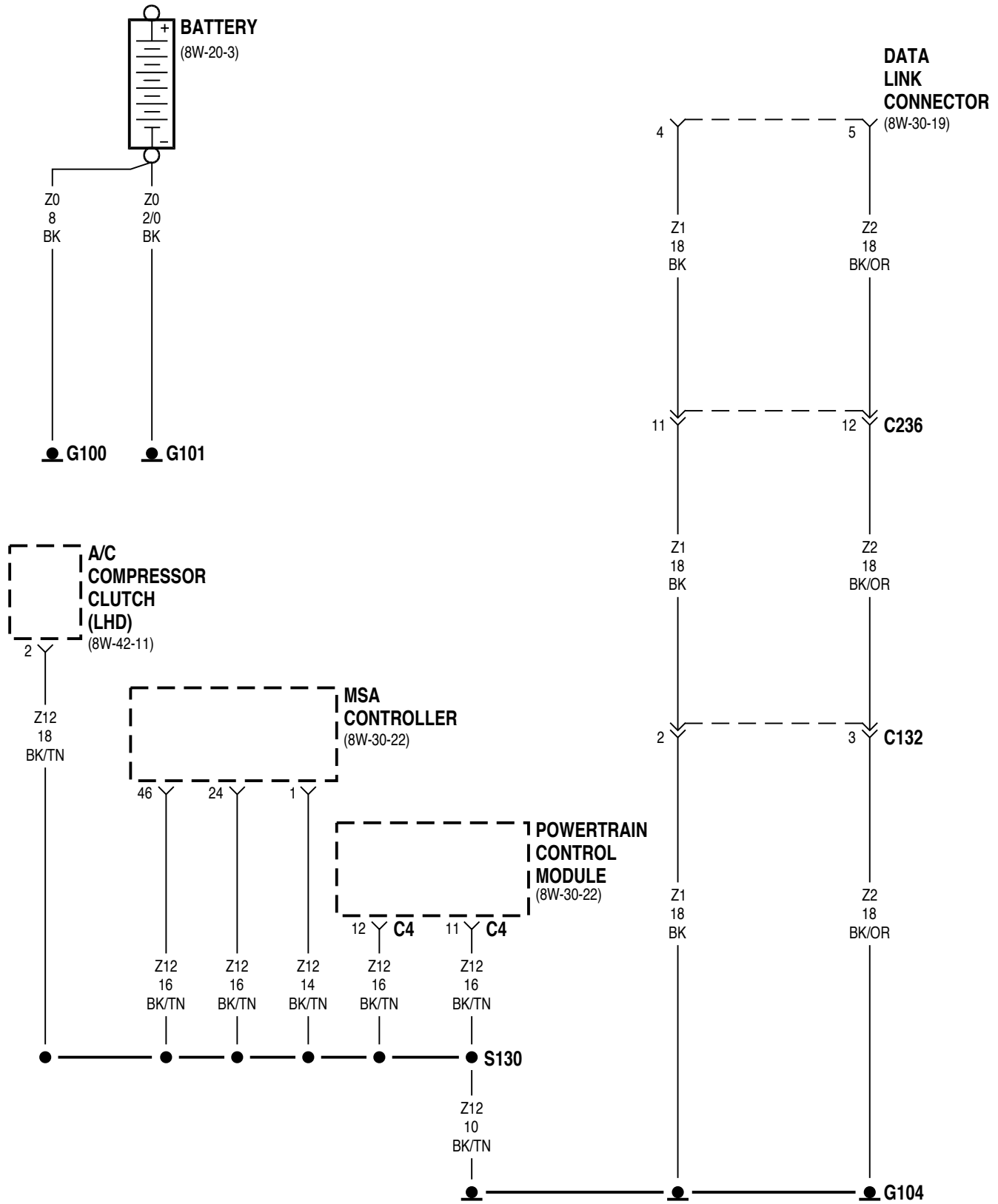


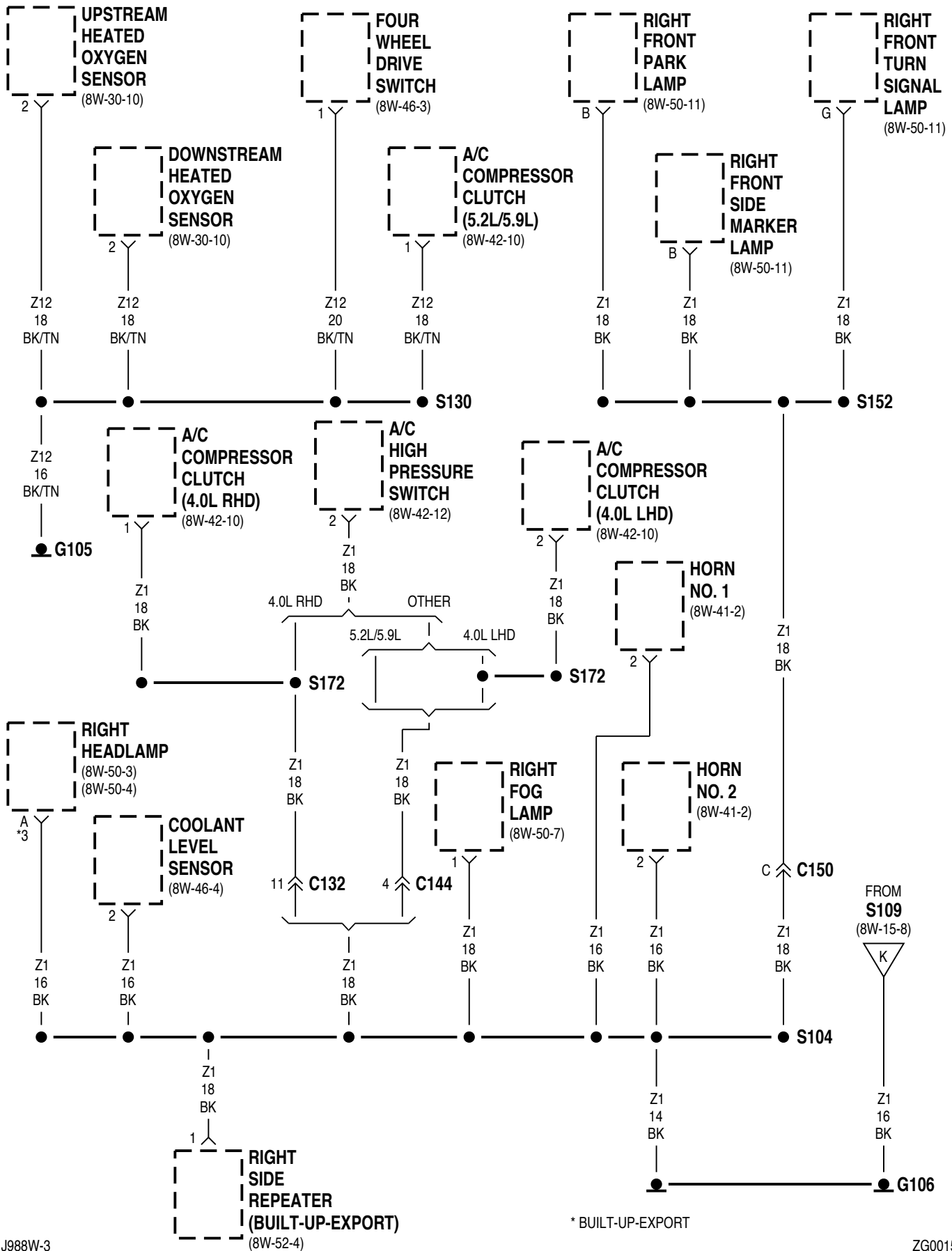


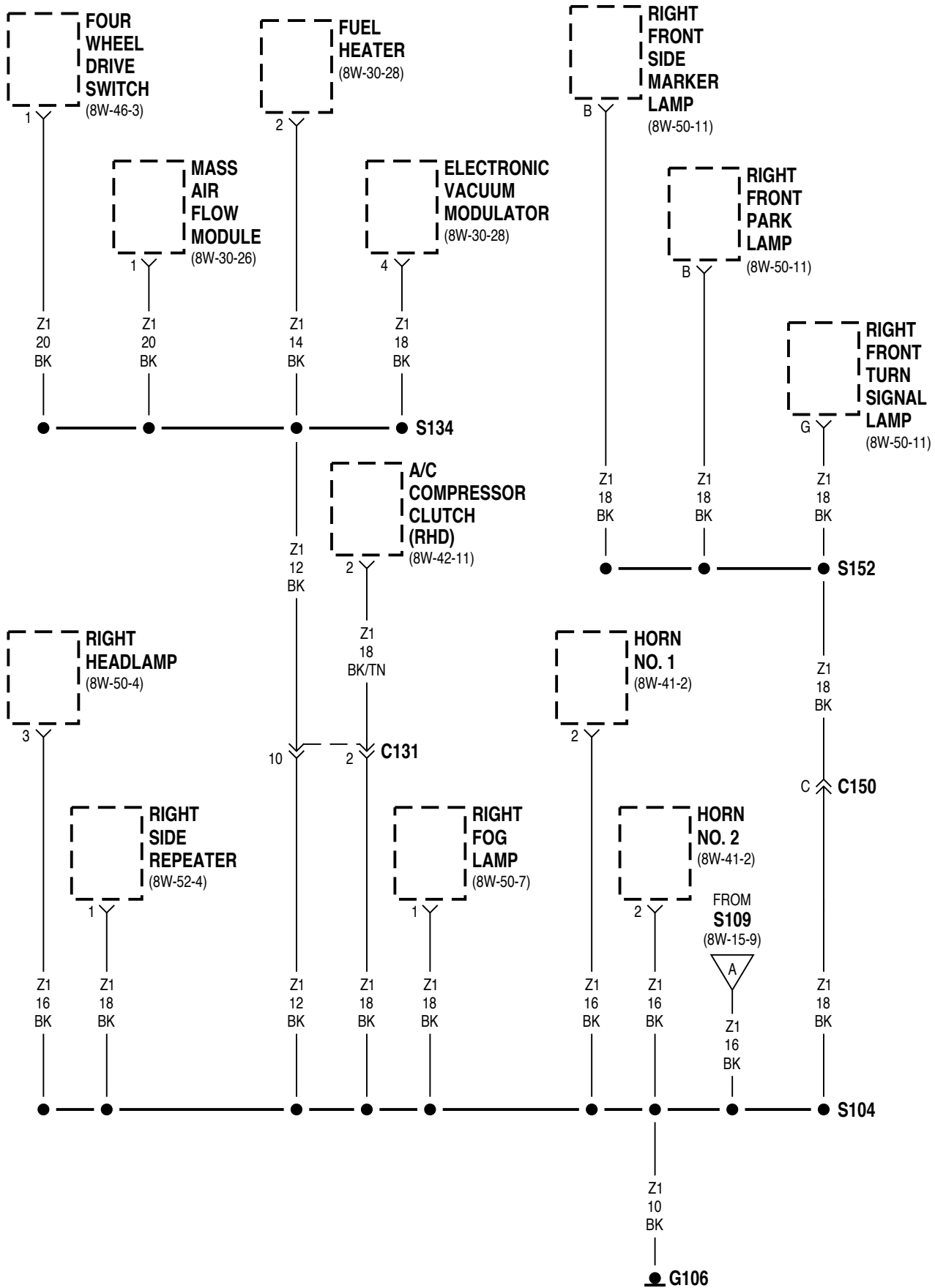
8W-15 GROUND DISTRIBUTION

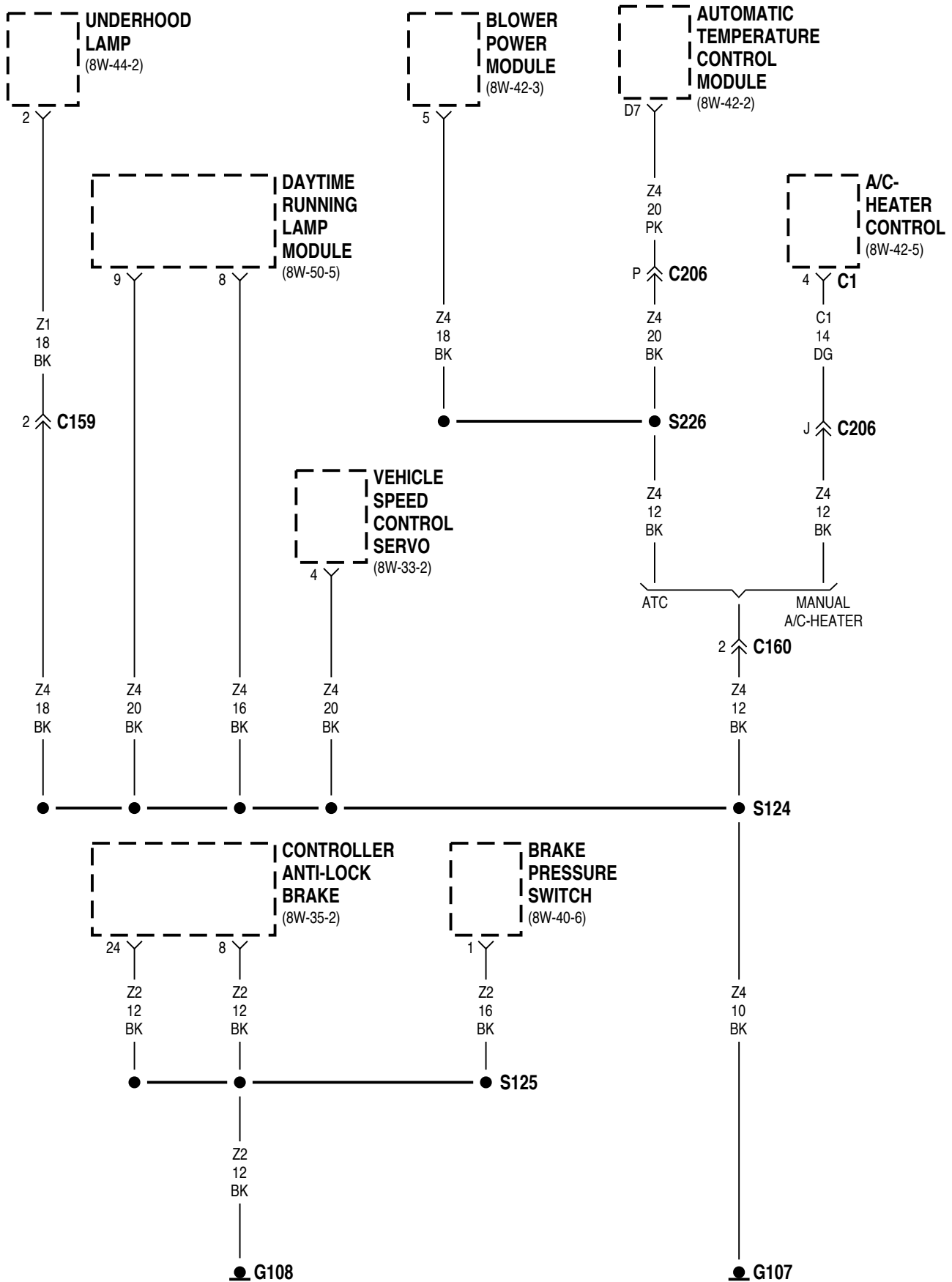
Component	Page	Component	Page
A/C Compressor Clutch	.8W-15-3, 4, 5	Junction Block	.8W-15-18, 19
A/C Heater Control	.8W-15-6, 7, 19	Key-In Switch/Halo Lamp	.8W-15-19
A/C High Pressure Switch	.8W-15-4	Lamp Outage Module	.8W-15-16
Airbag Control Module	.8W-15-20	Left Back-Up Lamp	.8W-15-11
Ash Receiver Lamp	.8W-15-19	Left Fog Lamp	.8W-15-8, 9
Automatic Day/Night Mirror	.8W-15-18	Left Front Park Lamp	.8W-15-8, 9
Automatic Temperature Control Module	.8W-15-6, 7	Left Front Side Marker Lamp	.8W-15-8, 9
Battery	.8W-15-2, 3	Left Front Turn Signal Lamp	.8W-15-8, 9
Blend Door Actuator	.8W-15-19	Left Headlamp	.8W-15-8, 9
Blower Power Module	.8W-15-6, 7	Left License Lamp	.8W-15-12
Body Control Module	.8W-15-20	Left Rear Fog Lamp	.8W-15-11
Brake Pressure Switch	.8W-15-6, 7	Left Rear Side Marker Lamp	.8W-15-11
Center High Mounted Stop Lamp No. 1	.8W-15-11	Left Rear Turn Signal Lamp	.8W-15-11
Center High Mounted Stop Lamp No. 2	.8W-15-11	Left Side Repeater	.8W-15-8, 9
Center High Mounted Stop Lamp No. 3	.8W-15-11	Left Tail/Stop Lamp	.8W-15-11
Cigar Lighter	.8W-15-19	Left Visor/Vanity Lamp	.8W-15-18
Cigar Lighter Relay	.8W-15-19	Liftgate Ajar Switch	.8W-15-12
Cigar Lighter/Power Outlet	.8W-15-19	Liftgate Cylinder Lock Switch	.8W-15-12
Clockspring	.8W-15-20	Liftglass Ajar Switch	.8W-15-12
Controller Anti-Lock Brake	.8W-15-6, 7	Liftglass Release Solenoid	.8W-15-12
Coolant Level Sensor	.8W-15-4	Lower Hose Coolant Switch	.8W-15-10
Cooling Fan Motor	.8W-15-10	Mass Air Flow Module	.8W-15-5
Courtesy Lamp Relay	.8W-15-18	Memory Seat Module	.8W-15-17
Data Link Connector	.8W-15-2, 3	MSA Controller	.8W-15-3
Daytime Running Lamp Module	.8W-15-6	Overhead Console	.8W-15-18
Diagnostic Connector	.8W-15-10	Passenger Door Courtesy Lamp	.8W-15-14
Dome/Reading Lamp	.8W-15-18	Passenger Door Module	.8W-15-14
Downstream Heated Oxygen Sensor	.8W-15-4	Passenger Front Cylinder Lock Switch	.8W-15-14
Driver Door Courtesy Lamp	.8W-15-16	Passenger Heated Seat Back	.8W-15-15
Driver Door Module	.8W-15-16	Passenger Heated Seat Cushion	.8W-15-15
Driver Front Cylinder Lock Switch	.8W-15-16	Passenger Lumbar Switch	.8W-15-15
Driver Heated Seat Back	.8W-15-17	Passenger Power Seat Switch	.8W-15-15
Driver Heated Seat Cushion	.8W-15-17	Passenger Rear Power Window Switch	.8W-15-14
Driver Lumbar Switch	.8W-15-17	Passenger Seat Heater Control Module	.8W-15-15
Driver Power Seat Switch	.8W-15-17	Power Amplifier	.8W-15-17
Driver Rear Power Window Switch	.8W-15-15	Power Outlet	.8W-15-19
Driver Seat Heater Control Module	.8W-15-17	Powertrain Control Module	.8W-15-2, 3
Electronic Flasher	.8W-15-18	Radio	.8W-15-17
Electronic Vacuum Modulator	.8W-15-5	Rear Washer Pump Motor	.8W-15-8, 9
Engine Starter Motor Relay	.8W-15-7	Rear Window Defogger	.8W-15-12
Factory Trailer Tow Connector	.8W-15-11	Rear Wiper Module	.8W-15-12
Floor Console Lamps	.8W-15-15	Right Back-Up Lamp	.8W-15-13
Four Wheel Drive Switch	.8W-15-4, 5	Right Fog Lamp	.8W-15-4, 5
Fuel Heater	.8W-15-5	Right Front Park Lamp	.8W-15-4, 5
Fuel Heater Relay	.8W-15-7	Right Front Side Marker Lamp	.8W-15-4, 5
Fuel Pump Module	.8W-15-14	Right Front Turn Signal Lamp	.8W-15-4, 5
Fuel Sender Unit	.8W-15-15	Right Headlamp	.8W-15-4, 5
G100	.8W-15-2, 3	Right License Lamp	.8W-15-12
G101	.8W-15-2, 3	Right Rear Fog Lamp	.8W-15-13
G104	.8W-15-2, 3	Right Rear Side Marker Lamp	.8W-15-13
G105	.8W-15-4	Right Rear Turn Signal Lamp	.8W-15-13
G106	.8W-15-4, 5	Right Side Repeater	.8W-15-4, 5
G107	.8W-15-6, 7	Right Tail/Stop Lamp	.8W-15-13
G108	.8W-15-6, 7	Right Visor/Vanity Lamp	.8W-15-18
G109	.8W-15-8, 9	Seat Belt Switch	.8W-15-15
G110	.8W-15-10	Stop Lamp Switch	.8W-15-9, 20
G111	.8W-15-7	Sunroof Control Module	.8W-15-18
G300	.8W-15-13	Switch Pod	.8W-15-19
G301	.8W-15-14	Trailer Tow Left Turn Relay	.8W-15-11
G302	.8W-15-15, 26	Trailer Tow Right Turn Relay	.8W-15-11
G303	.8W-15-20	Trailer Tow Stop Lamp Relay	.8W-15-11
Generator	.8W-15-2	Underhood Lamp	.8W-15-6, 7, 9
Glove Box Lamp	.8W-15-19	Upper Hose Coolant Switch	.8W-15-10
Headlamp Leveling Switch	.8W-15-20	Upstream Heated Oxygen Sensor	.8W-15-4
Headlamp Switch	.8W-15-20	Vehicle Information Center/ Graphic Display Module	.8W-15-16, 19, 20
High Pressure Cut-Out Switch	.8W-15-10	Vehicle Speed Control Servo	.8W-15-6, 7
High Speed Cooling Fan Relay	.8W-15-10	Windshield Washer Pump Motor	.8W-15-8, 9
Horn No. 1	.8W-15-4, 5	Windshield Wiper Motor	.8W-15-8, 9
Horn No. 2	.8W-15-4, 5	Wiper Fluid Level Sensor	.8W-15-8, 9
Instrument Cluster	.8W-15-19, 20		

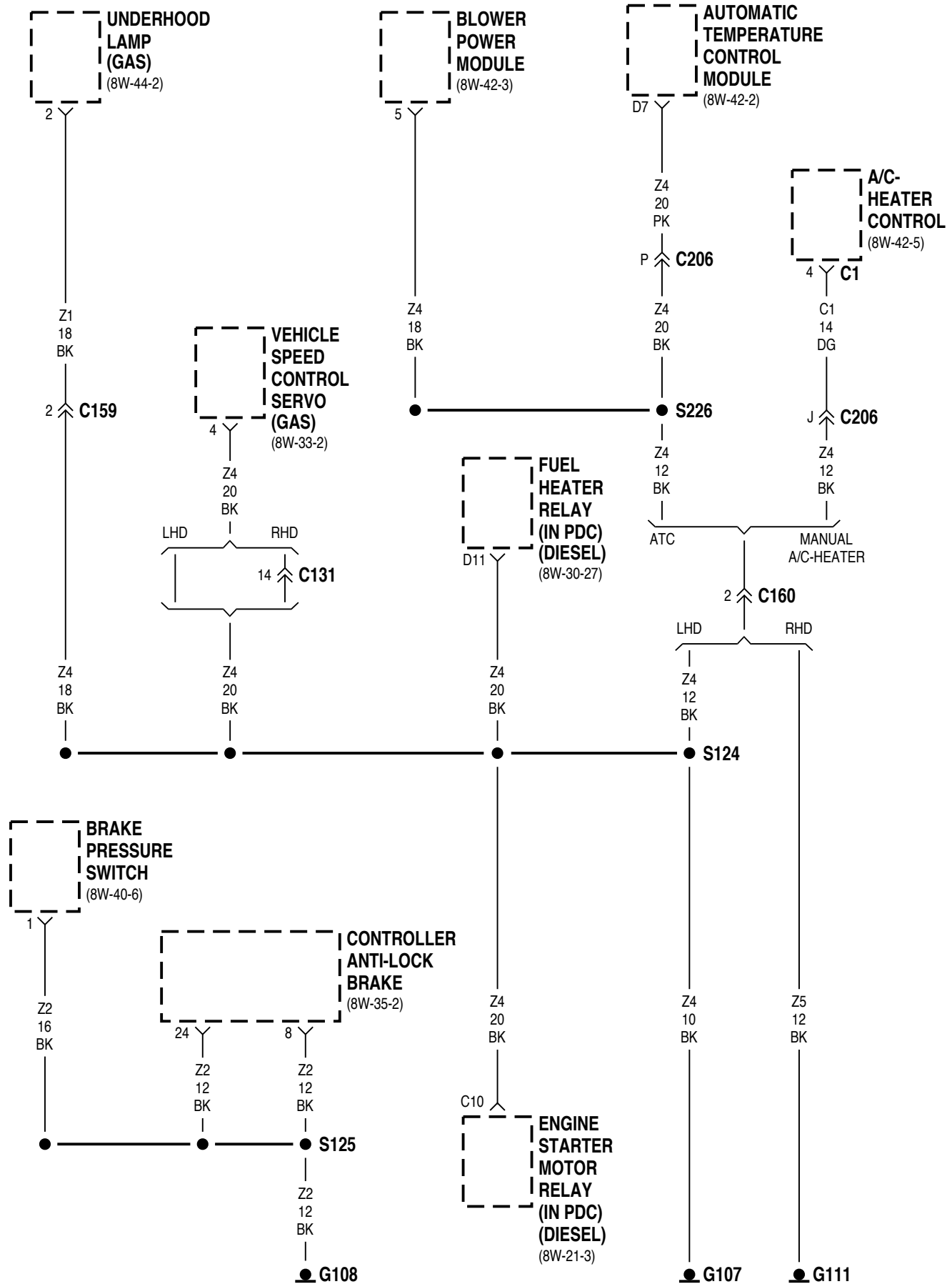


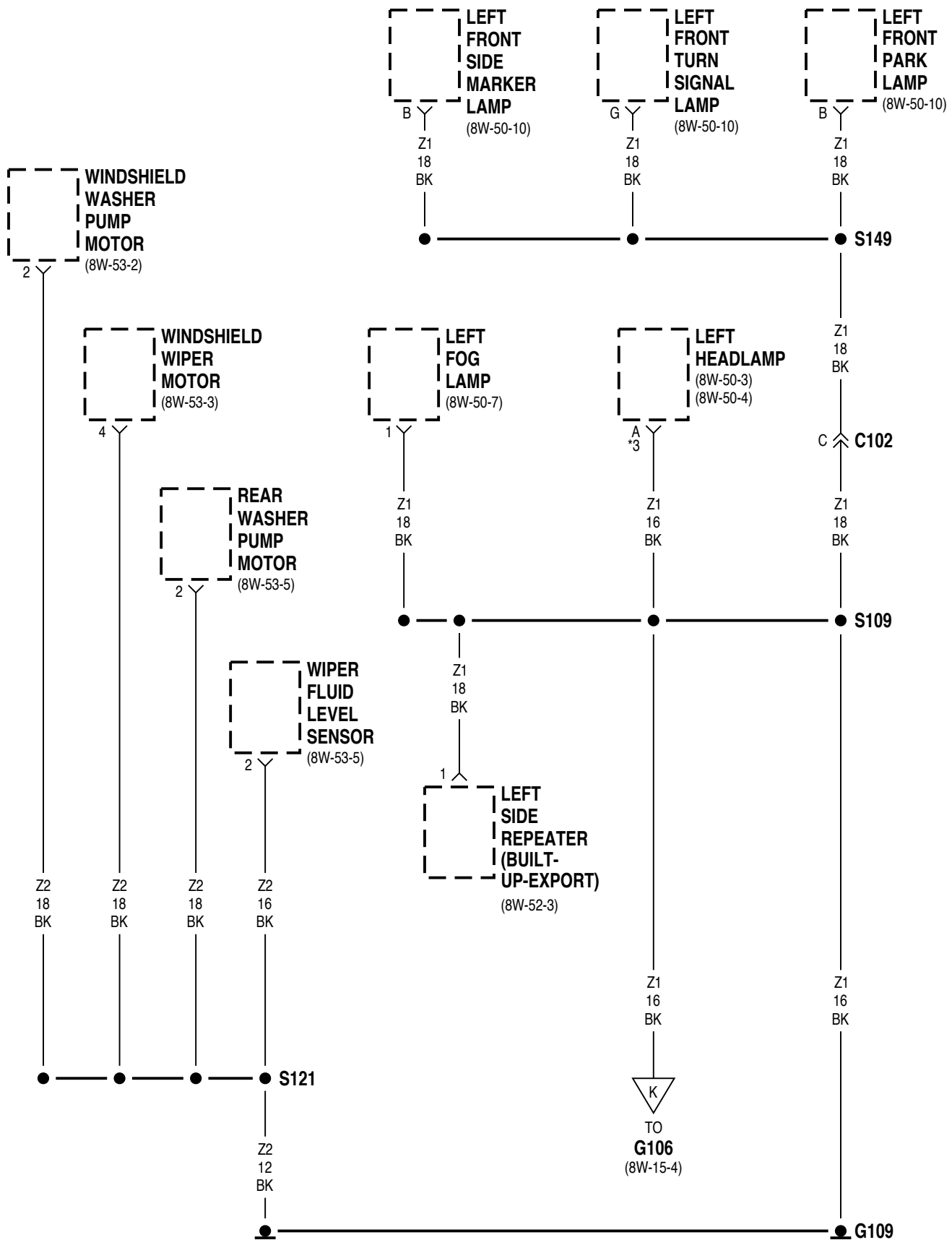




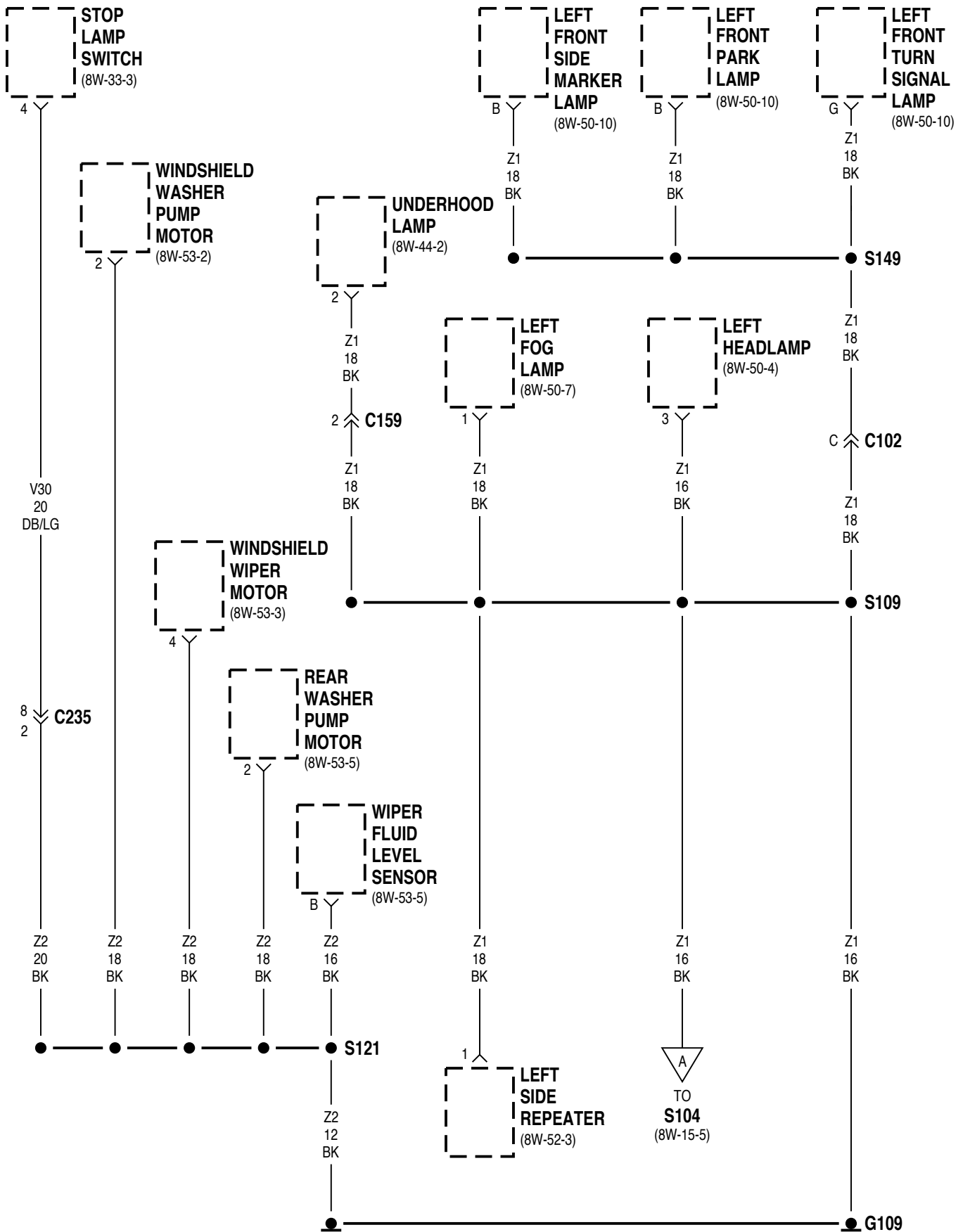


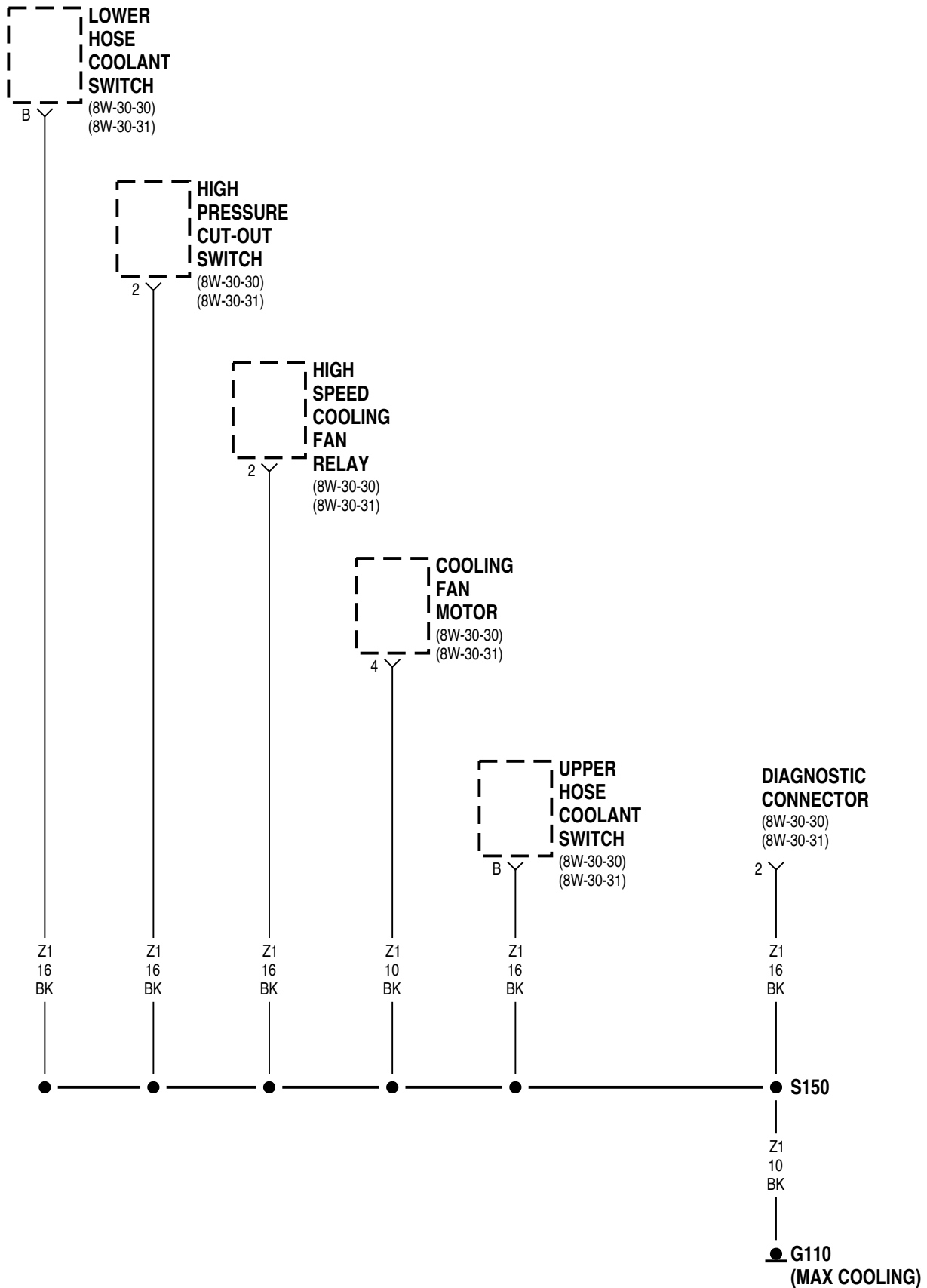


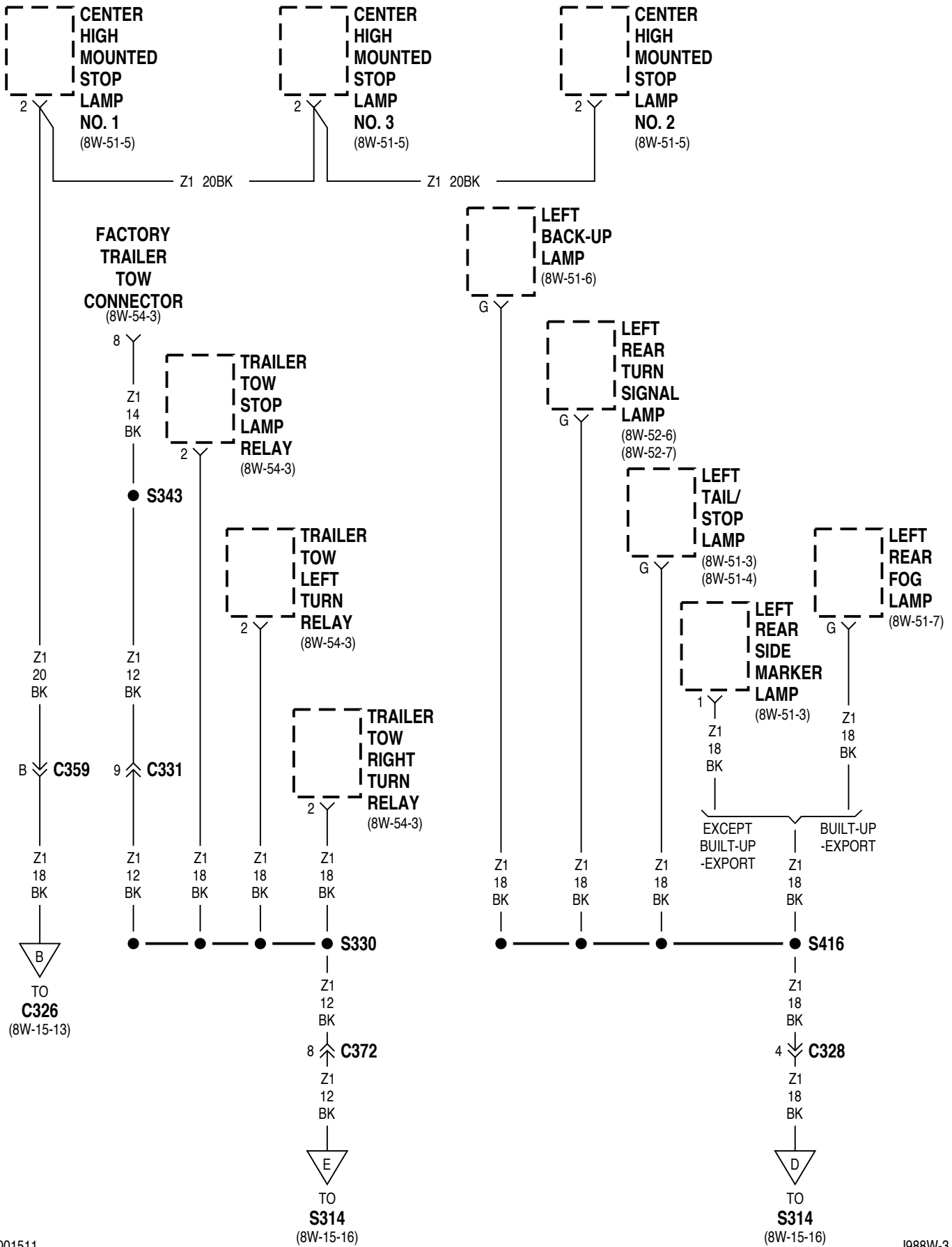


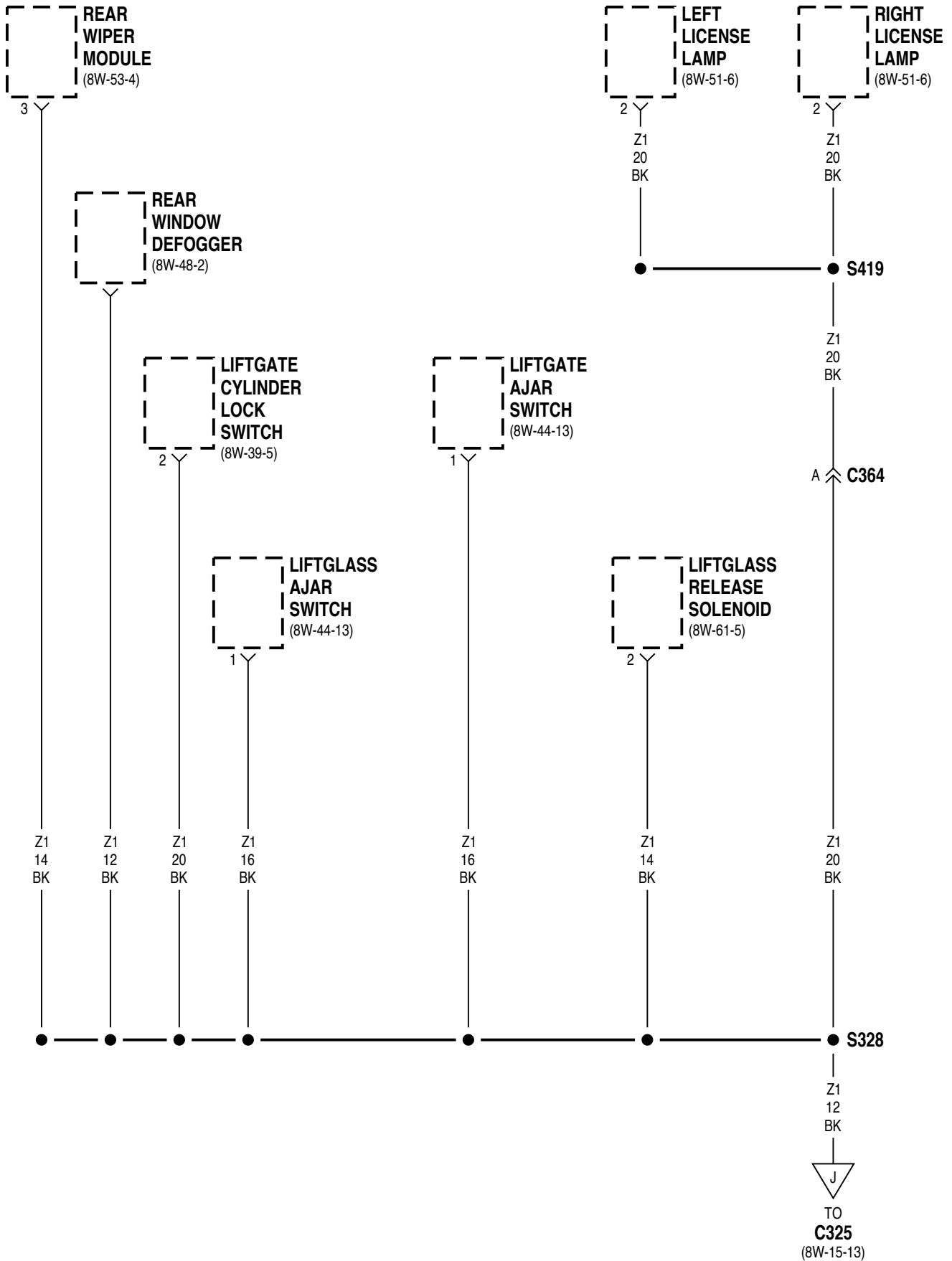


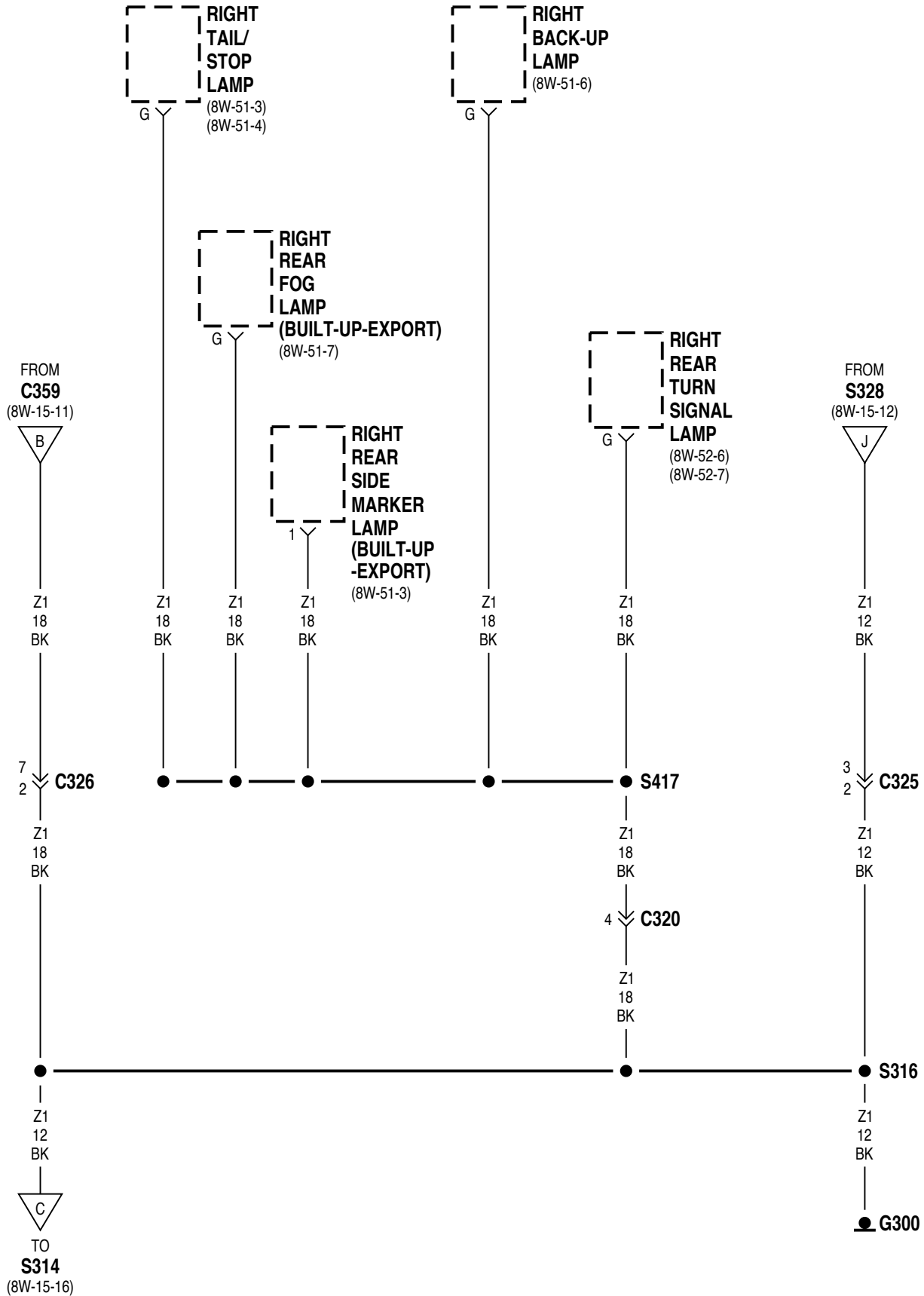
* BUILT-UP-EXPORT

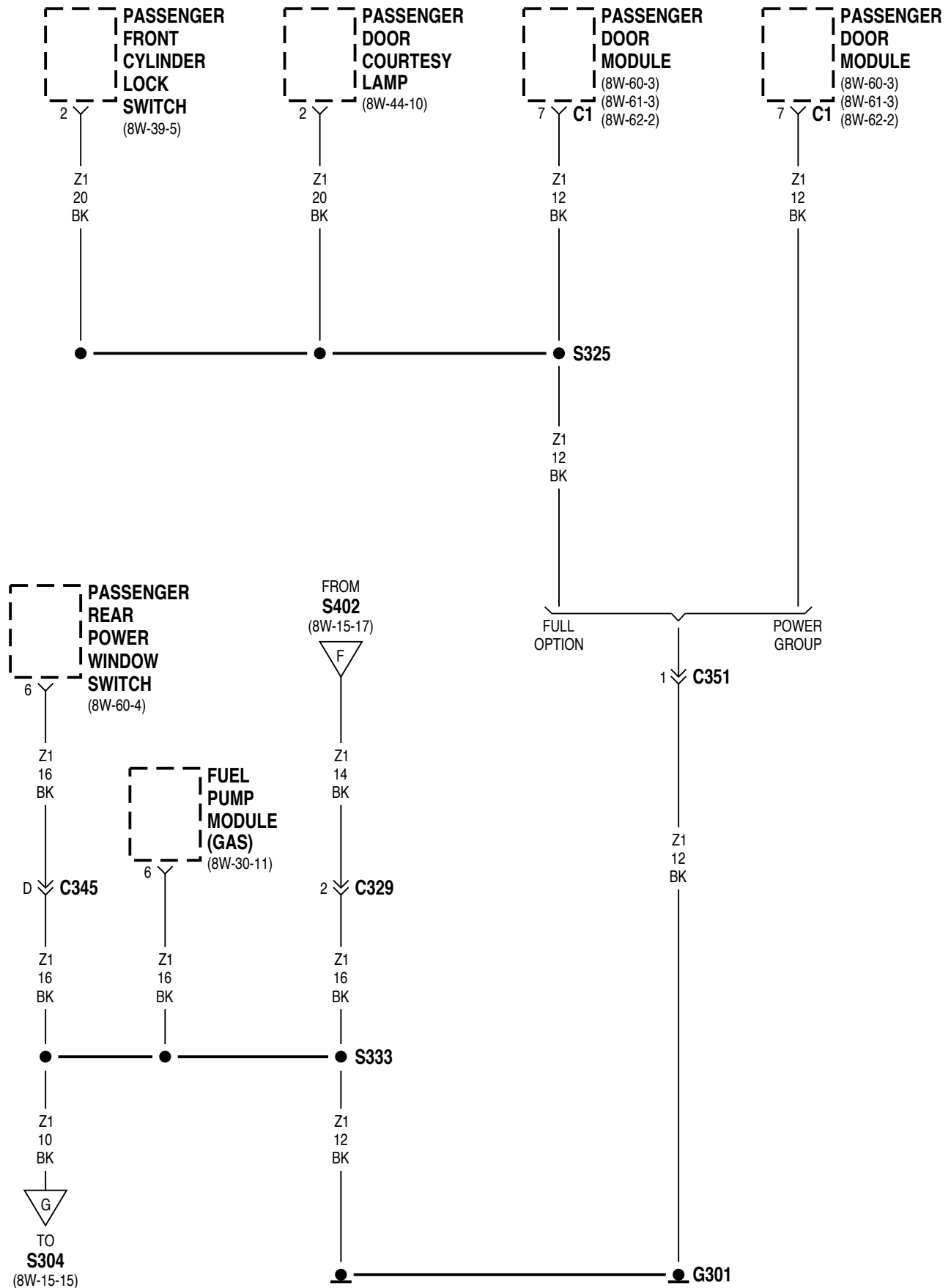


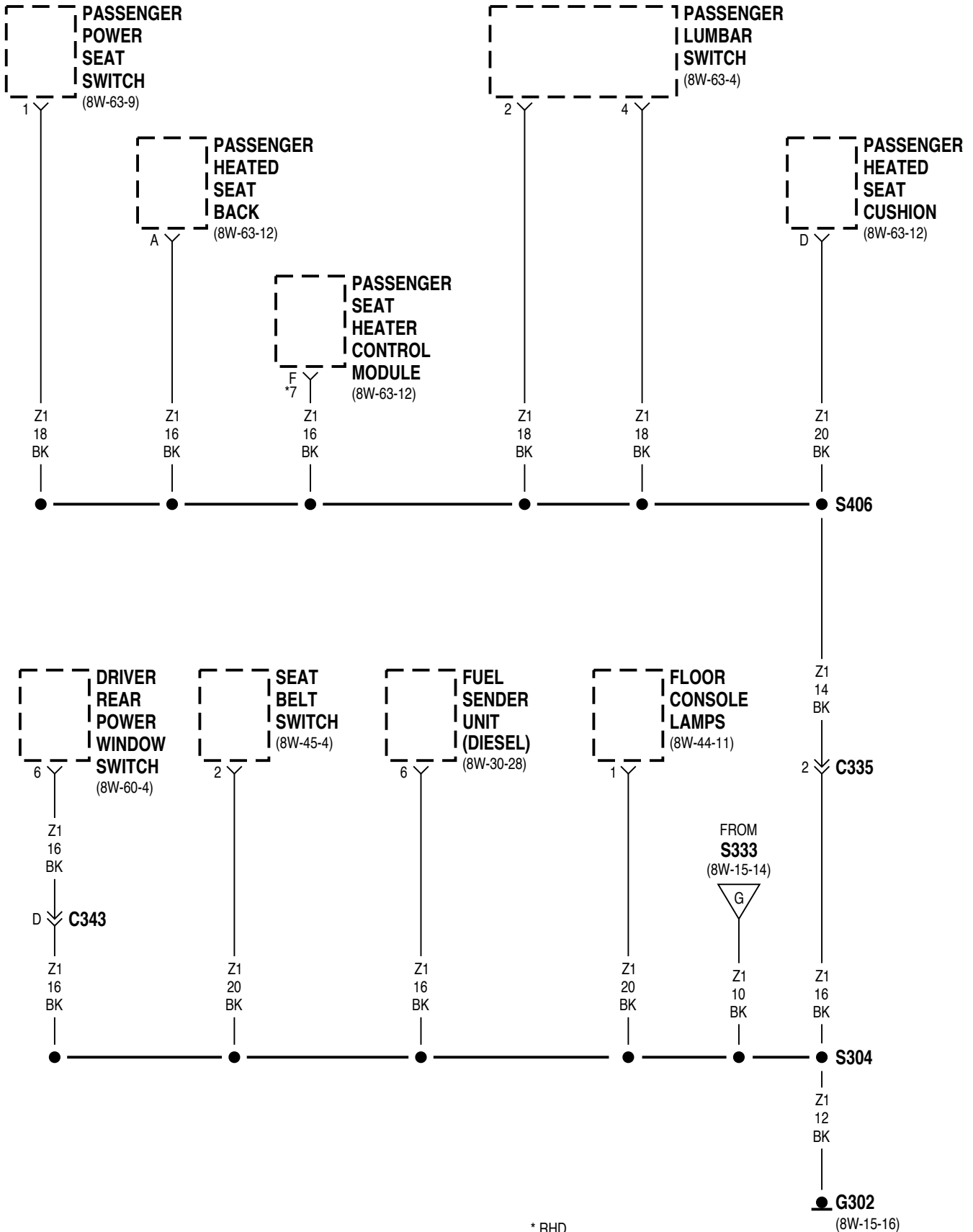


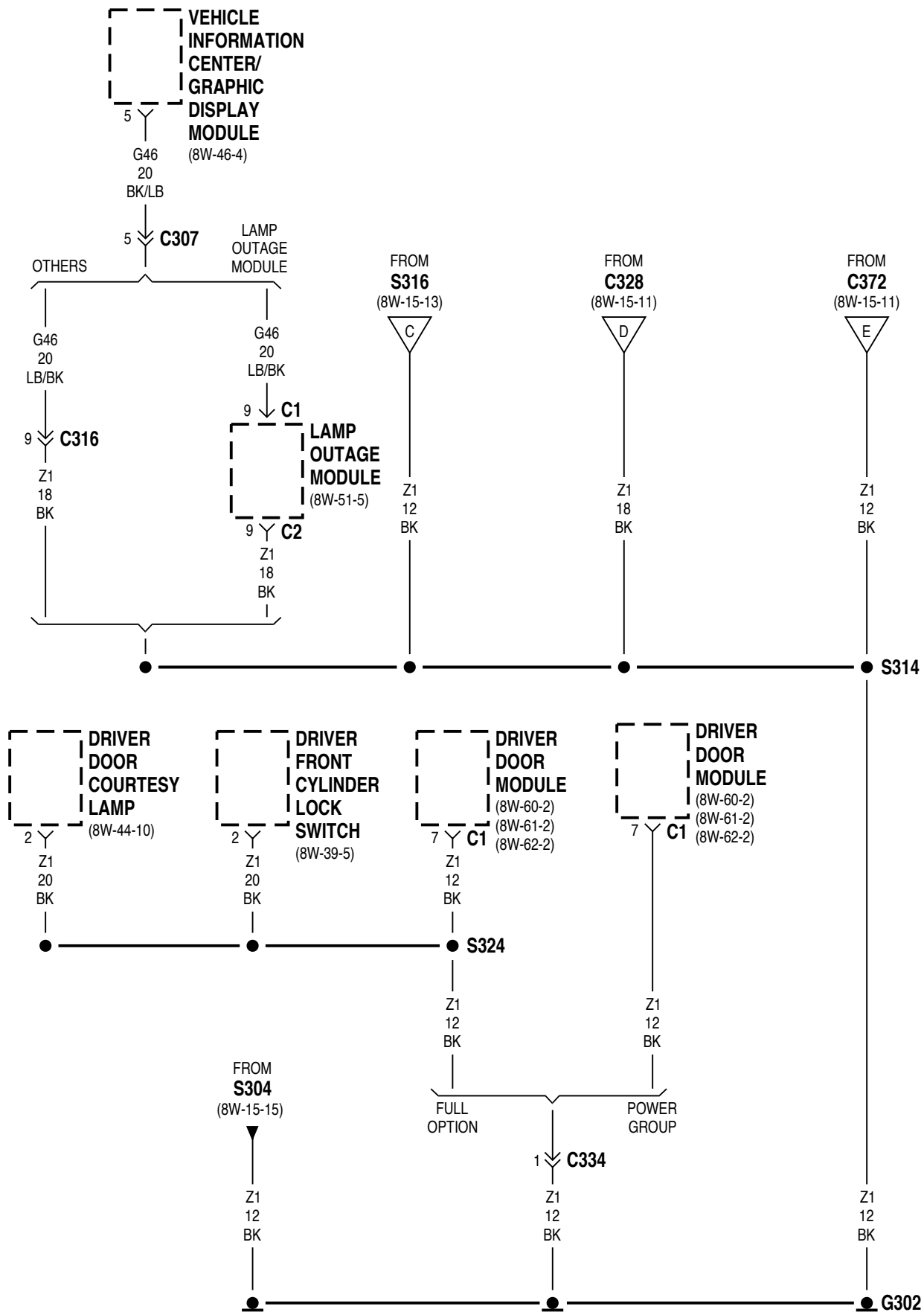


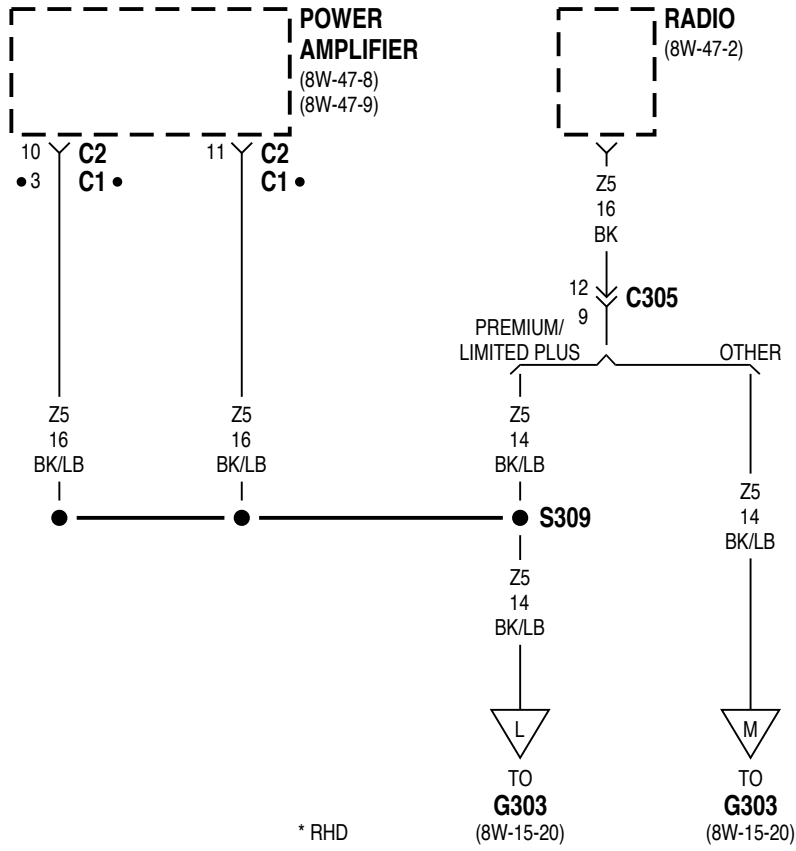
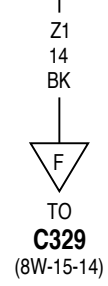
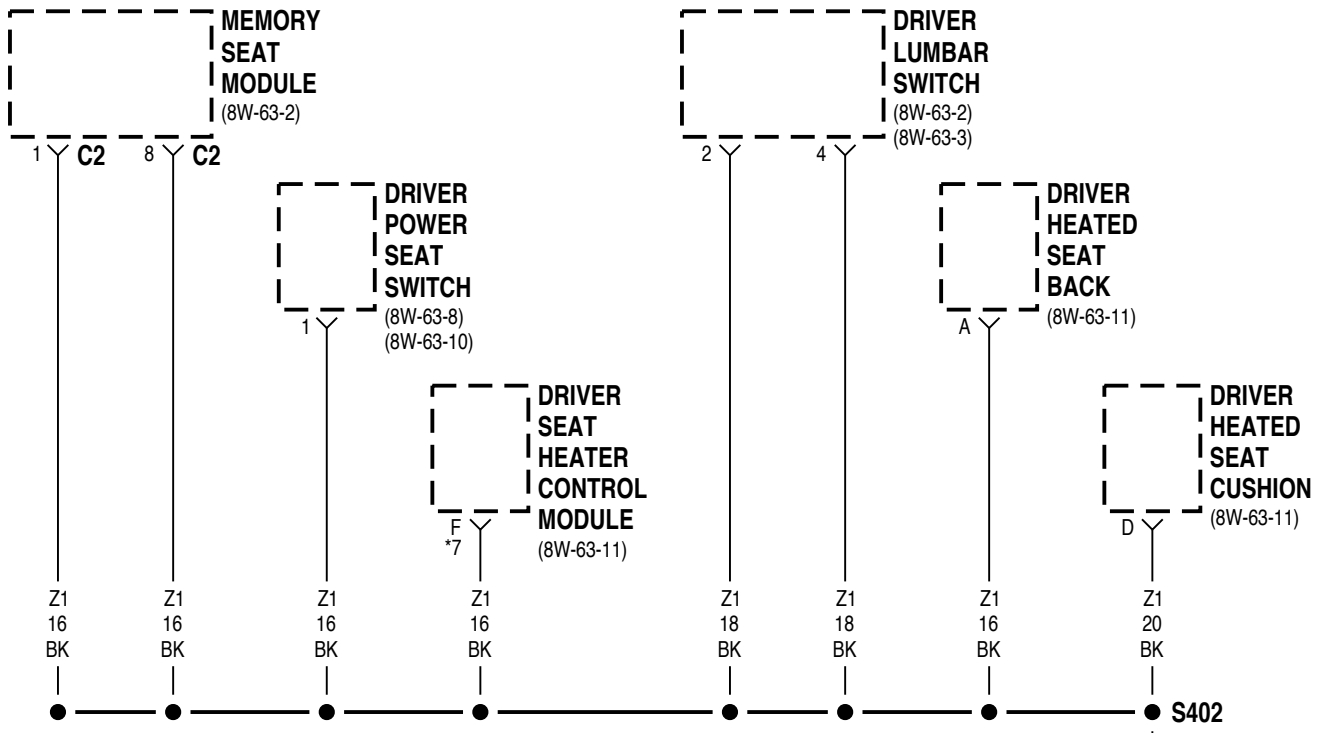




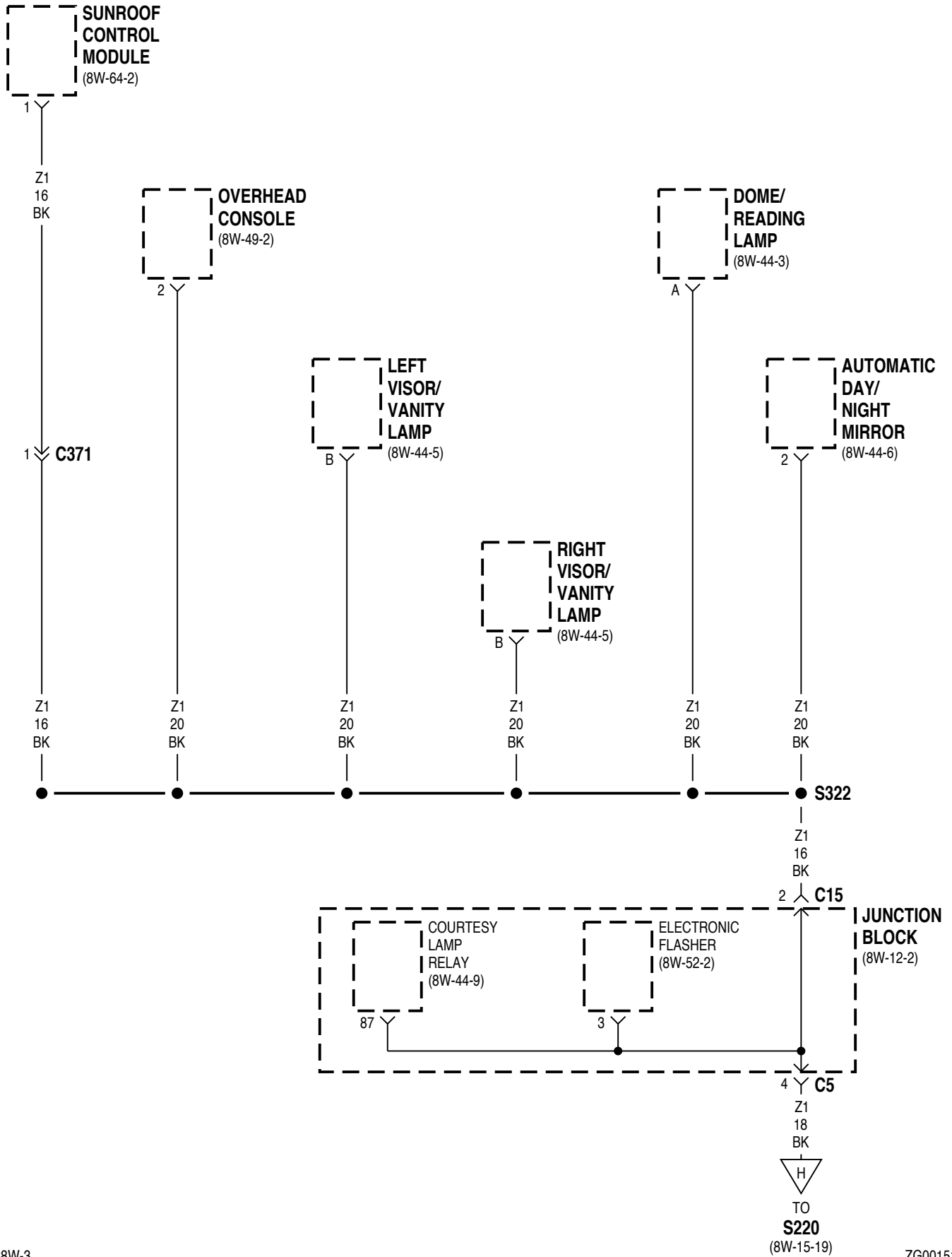


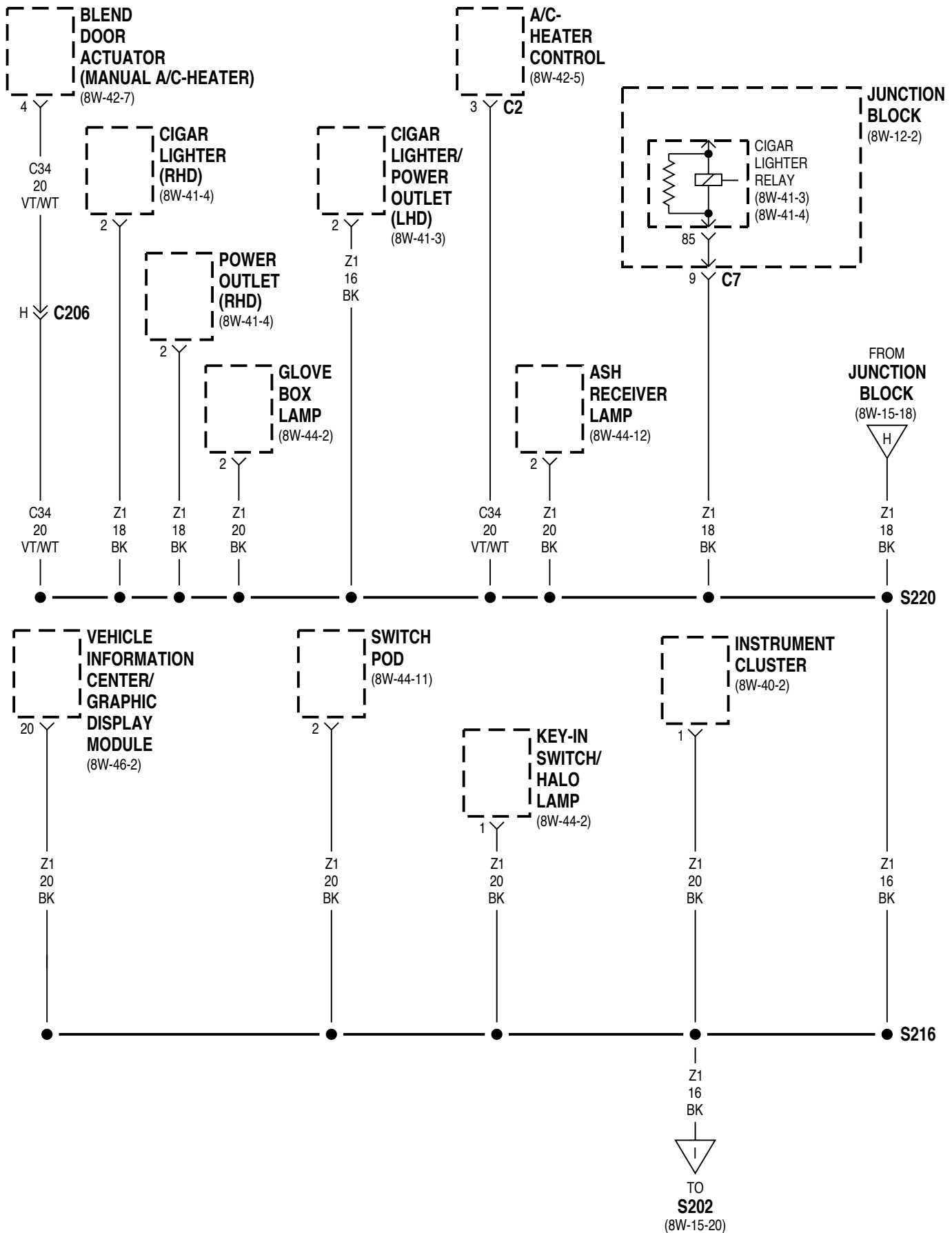


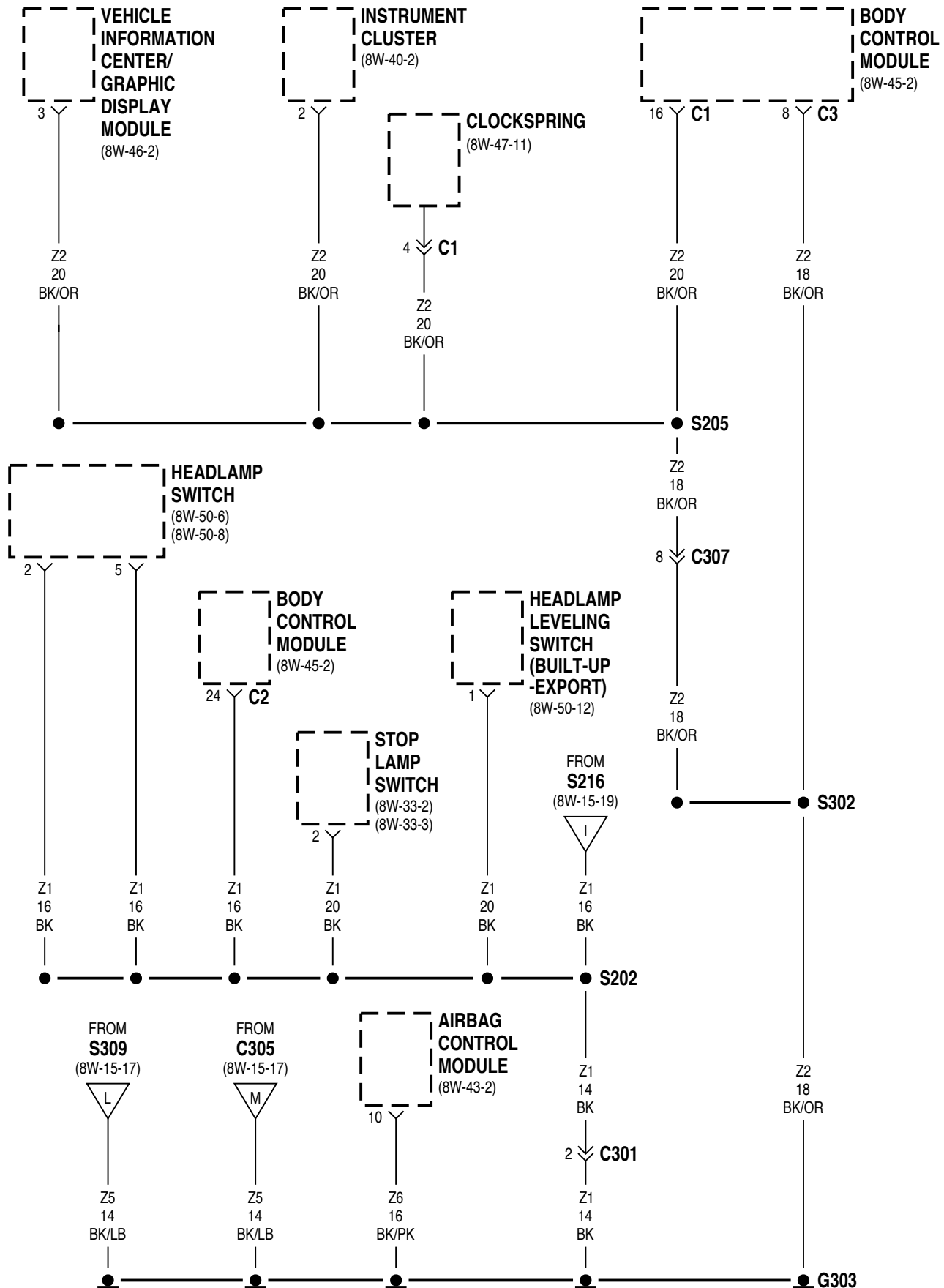




* RHD
 • LIMITED PLUS

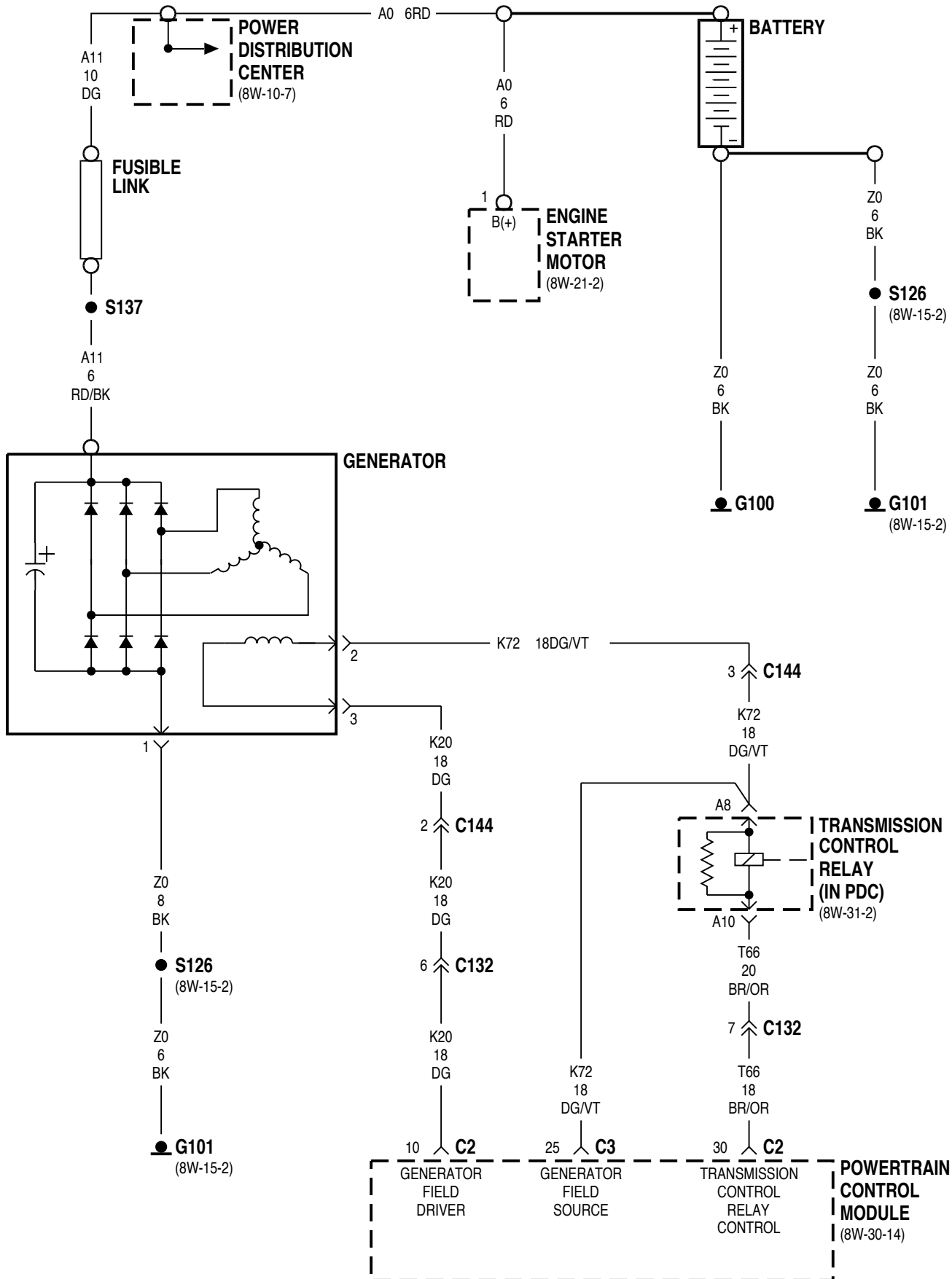


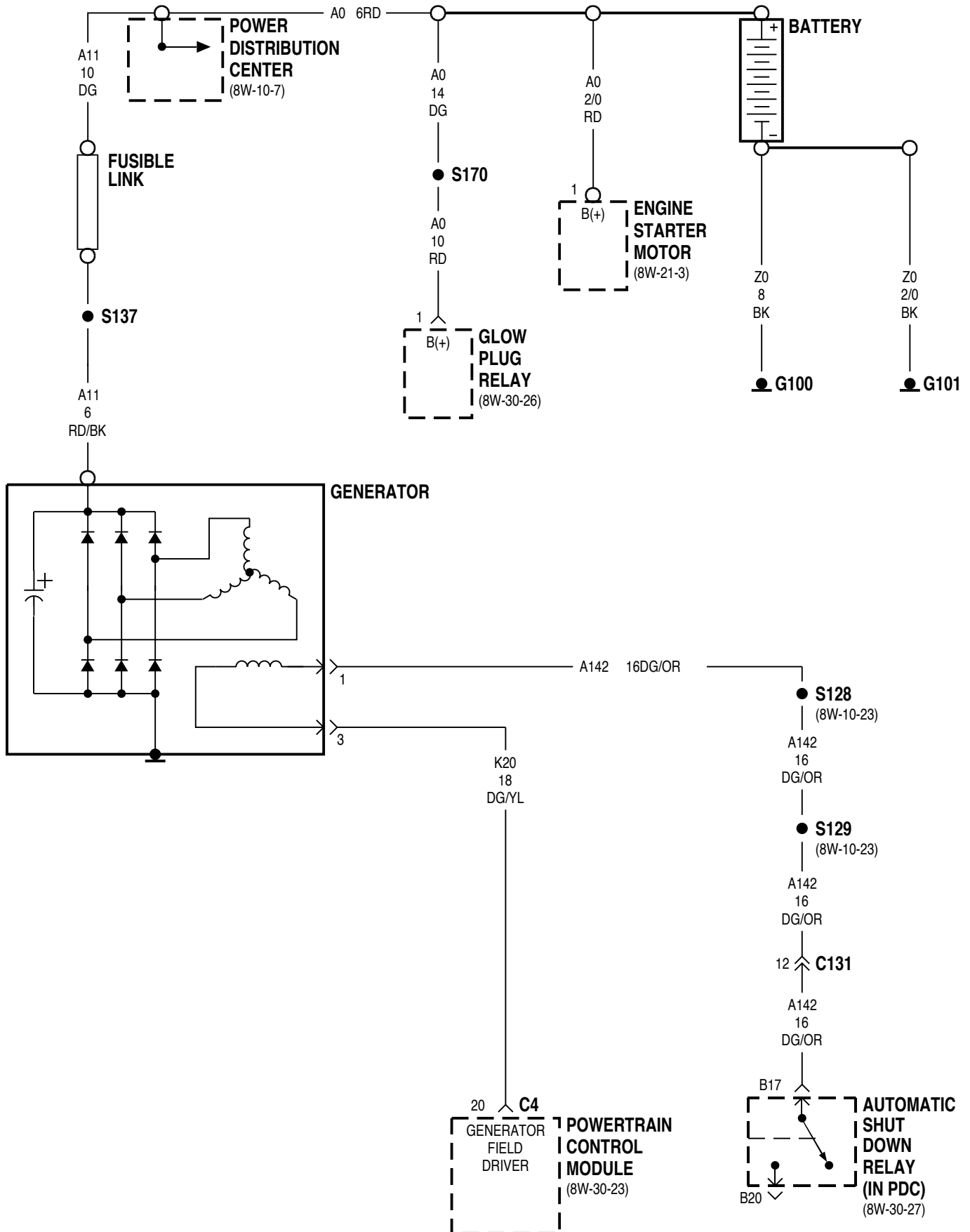




8W-20 CHARGING SYSTEM

Component	Page	Component	Page
Automatic Shutdown Relay8W-20-3	Generator8W-20-, 3
Battery8W-20-2, 3	Glow Plug Relay8W-20-3
Engine Starter Motor8W-20-2, 3	Power Distribution Center8W-20-2, 3
Fusible Link8W-20-2, 3	Powertrain Control Module.8W-20-2, 3
G1008W-20-2, 3	Transmission Control Relay8W-20-2
G1018W-20-2, 3		

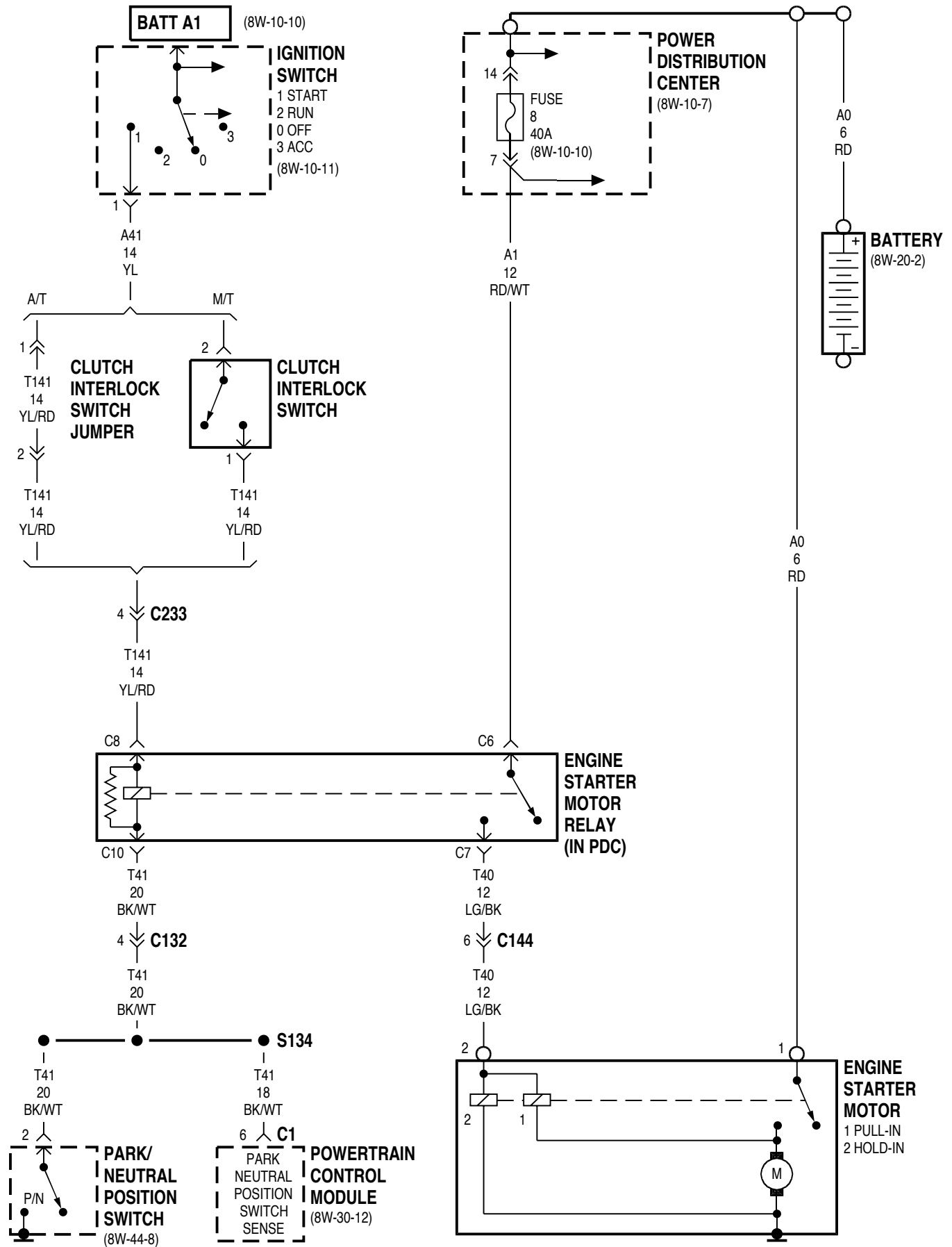


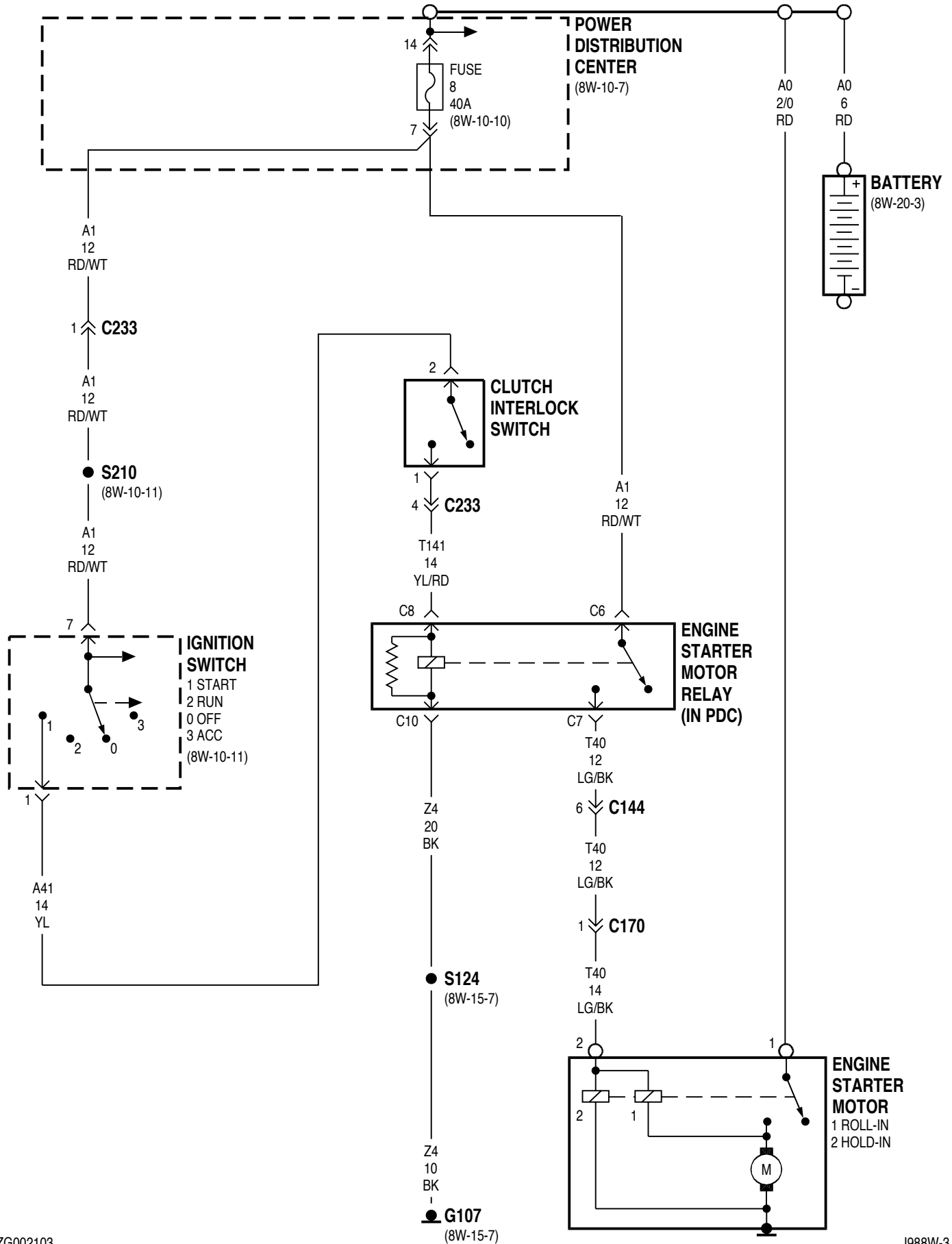


8W-21 STARTING SYSTEM

Component	Page	Component	Page
Battery8W-21-2, 3	G1078W-21-3
Clutch Interlock Switch8W-21-2, 3	Ignition Switch8W-21-2, 3
Clutch Interlock Switch Jumper8W-21-2	Park/Neutral Position Switch8W-21-2
Engine Starter Motor8W-21-2, 3	Power Distribution Center8W-21-2, 3
Engine Starter Motor Relay8W-21-2, 3	Powertrain Control Module.8W-21-2
Fuse 8 (PDC)8W-21-2, 3		

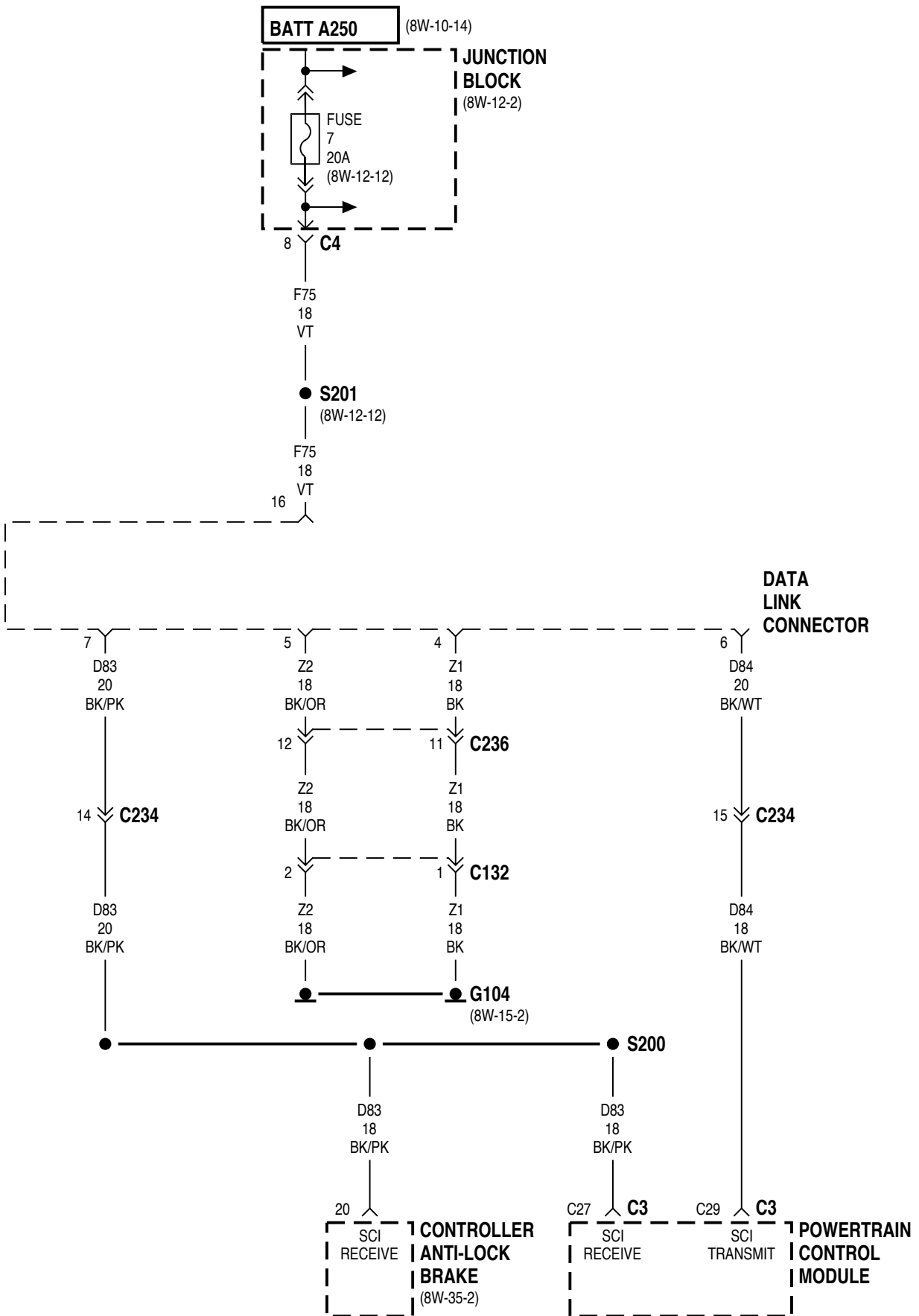
GAS

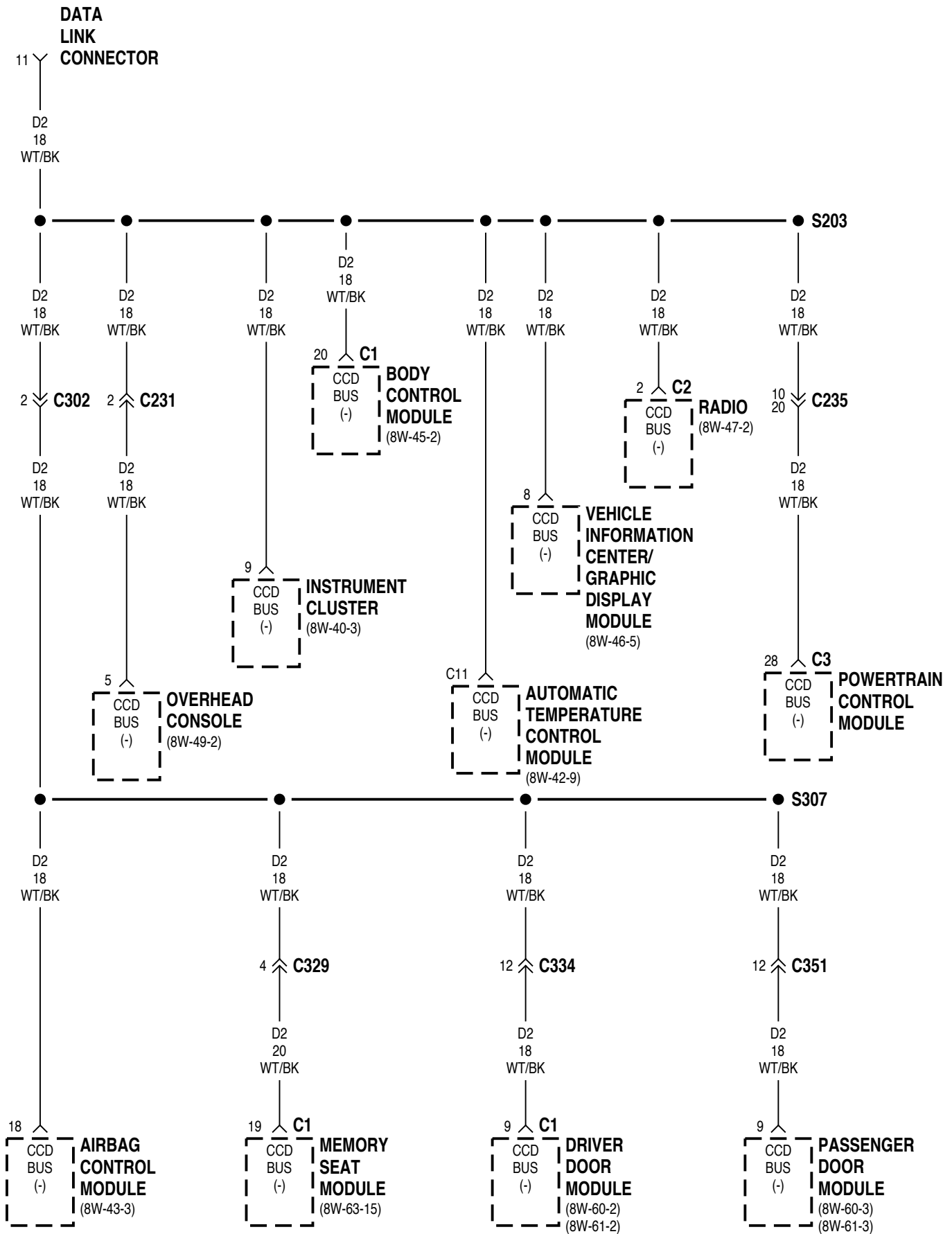


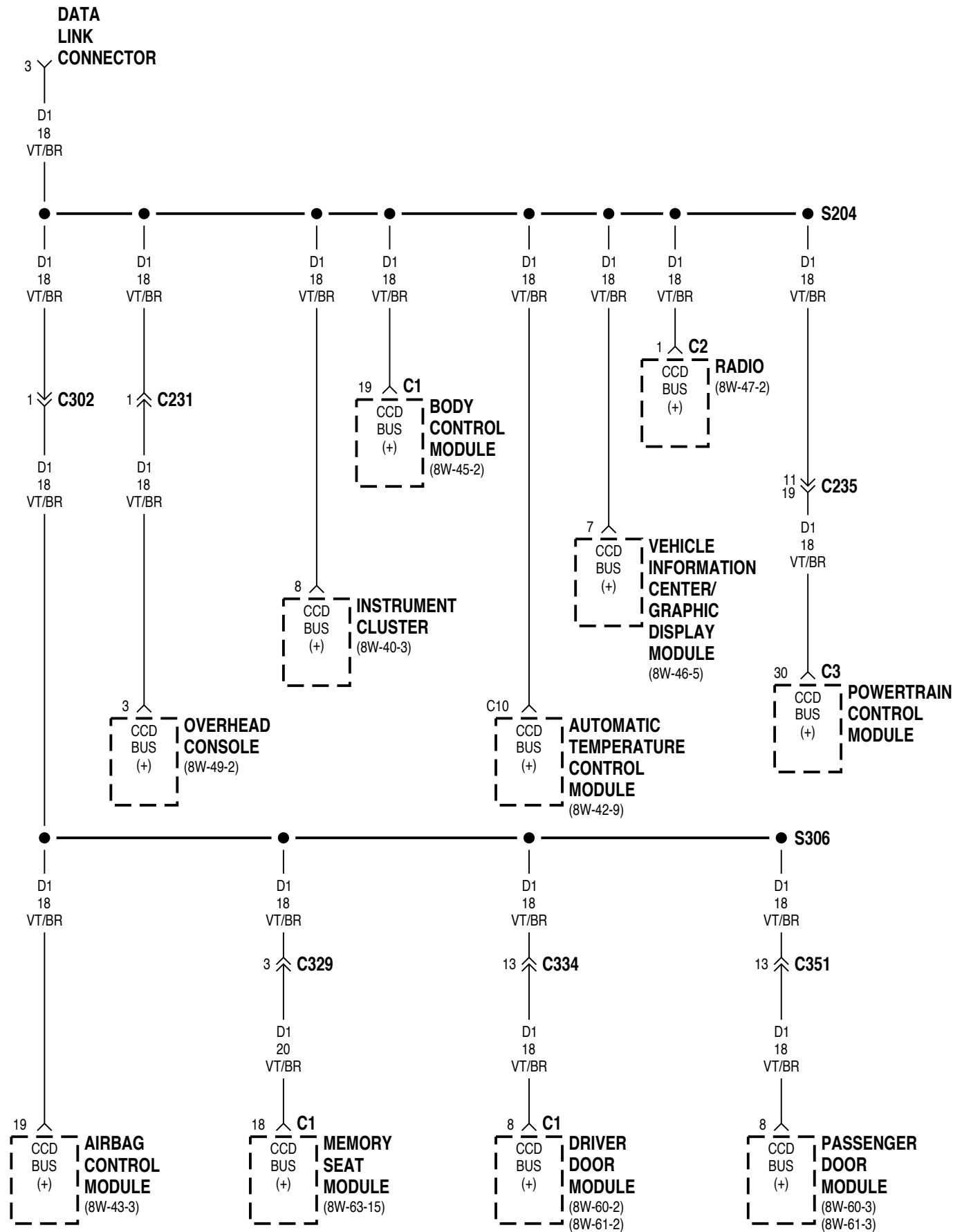


8W-30 FUEL/IGNITION SYSTEMS

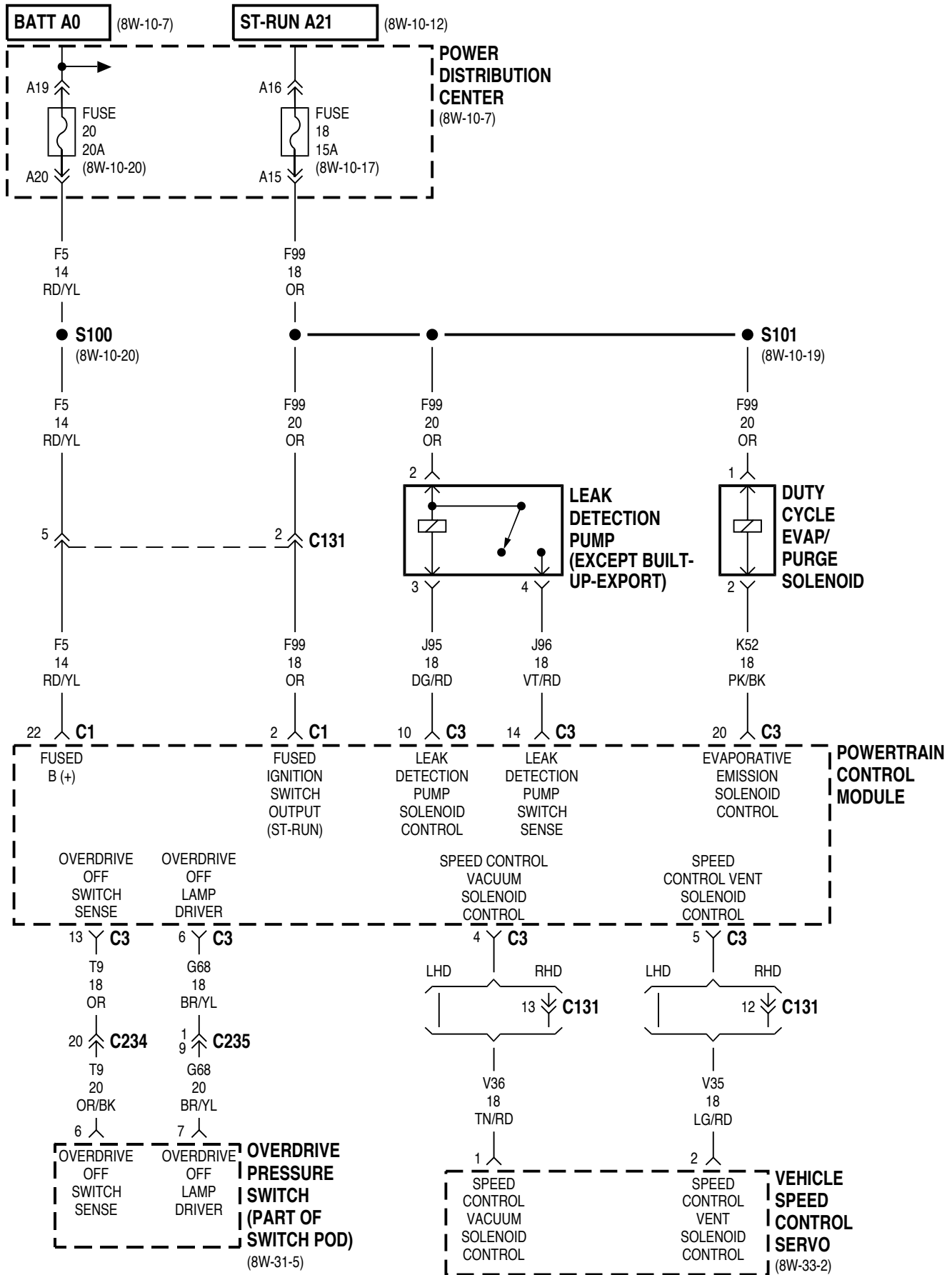
Component	Page	Component	Page
A/C Compressor Clutch Relay	8W-30-15, 27	G123	8W-30-24
A/C Low Pressure Switch	8W-30-15, 22	G301	8W-30-11
Airbag Control Module	8W-30-3, 4, 20, 21	G302	8W-30-28
Automatic Shutdown		G303	8W-30-12
Relay	8W-30-6, 10, 16, 17, 18, 27	Generator	8W-30-14, 23
Automatic Temperature Control		Glow Plug	8W-30-26
Module	8W-30-3, 4, 20, 21	Glow Plug Relay	8W-30-26
Battery	8W-30-26	High Pressure Cut-Out Switch	8W-30-30, 31
Battery Temperature Sensor	8W-30-11	High Speed Cooling Fan Relay	8W-30-30, 31
Body Control Module	8W-30-3, 4, 20, 21	Idle Air Control Motor	8W-30-9
Camshaft Position Sensor	8W-30-7	Ignition Coil	8W-30-6
Clockspring	8W-30-11, 13, 24	Ignition Relay	8W-30-30, 31
Controller Anti-Lock Brake	8W-30-2, 19	Instrument Cluster	8W-30-3, 4, 20, 21
Coolant Level Sensor	8W-30-29	Intake Air Temperature Sensor	8W-30-8
Cooling Fan Motor	8W-30-30, 31	Junction Block	8W-30-2, 19
Crankshaft Position Sensor	8W-30-7, 24	Leak Detection Pump	8W-30-5
Cruise Switch No. 1	8W-30-13	Low Speed Cooling Fan Relay	8W-30-30, 31
Cruise Switch No. 2	8W-30-13	Lower Hose Coolant Switch	8W-30-30, 31
Data Link Connector	8W-30-2, 3, 4, 19, 20, 21	Manifold Absolute Pressure Sensor	8W-30-7, 8
Diagnostic Connector	8W-30-30, 31	Mass Air Flow Module	8W-30-26
Downstream Heated Oxygen Sensor	8W-30-10	Memory Seat Module	8W-30-3, 4, 20, 21
Driver Door Module	8W-30-3, 4, 20, 21	MSA Controller	8W-30-19, 22, 23, 24, 25, 26, 27, 29
Duty Cycle Evap/Purge Solenoid	8W-30-5	Needle Sensor	8W-30-24
Electronic Vacuum Modulator	8W-30-28	Oil Pressure Sensor	8W-30-12, 29
Engine Coolant Temperature Sensor	8W-30-8, 29	Output Shaft Speed Sensor	8W-30-12
Fuel Heater	8W-30-28	Overdrive Pressure Switch	8W-30-5
Fuel Heater Relay	8W-30-27	Overhead Console	8W-30-3, 4, 20, 21
Fuel Injector No. 1	8W-30-16, 17	Park/Neutral Position Switch	8W-30-12
Fuel Injector No. 2	8W-30-16, 18	Passenger Door Module	8W-30-3, 4, 20, 21
Fuel Injector No. 3	8W-30-16, 17	Pedal Position Sensor	8W-30-23
Fuel Injector No. 4	8W-30-16, 18	Power Distribution Center	8W-30-5, 6, 10, 11, 14, 16, 17, 18, 22, 27, 30, 31
Fuel Injector No. 5	8W-30-16, 17	Powertrain Control Module	8W-30-2, 3, 4, 5, 6, 7, 8, 9, 10, 11, 12, 13, 14, 15, 16, 17, 18, 19, 20, 21, 22, 23, 24, 27, 28, 29
Fuel Injector No. 6	8W-30-16, 18	Radio	8W-30-3, 4, 20, 21
Fuel Injector No. 7	8W-30-17	Stop Lamp Switch	8W-30-12, 29
Fuel Injector No. 8	8W-30-18	Throttle Position Sensor	8W-30-7, 8
Fuel Pump Module	8W-30-11, 25, 26	Transmission Control Relay	8W-30-14
Fuel Pump Relay	8W-30-11	Transmission Solenoid Assembly	8W-30-14, 15
Fuel Sender Unit	8W-30-28	Upper Hose Coolant Switch	8W-30-30, 31
Fuse 2 (PDC)	8W-30-30, 31	Upstream Heated Oxygen Sensor	8W-30-10
Fuse 4 (PDC)	8W-30-27	Vehicle Information Center/Graphic Display Module	8W-30-3, 4, 20, 21, 28
Fuse 7 (JB)	8W-30-2, 19	Vehicle Speed Control Servo	8W-30-5, 12
Fuse 16 (PDC)	8W-30-11, 22	Vehicle Speed Sensor	8W-30-13, 24
Fuse 17 (PDC)	8W-30-14	Water In Fuel Sensor	8W-30-24
Fuse 18 (PDC)	8W-30-5, 6, 11, 22, 27, 30, 31		
Fuse 20 (PDC)	8W-30-5, 6, 27		
G104	8W-30-2, 14, 19, 22		
G105	8W-30-10		
G106	8W-30-26, 28		
G107	8W-30-27		
G110	8W-30-30, 31		
G118	8W-30-28		



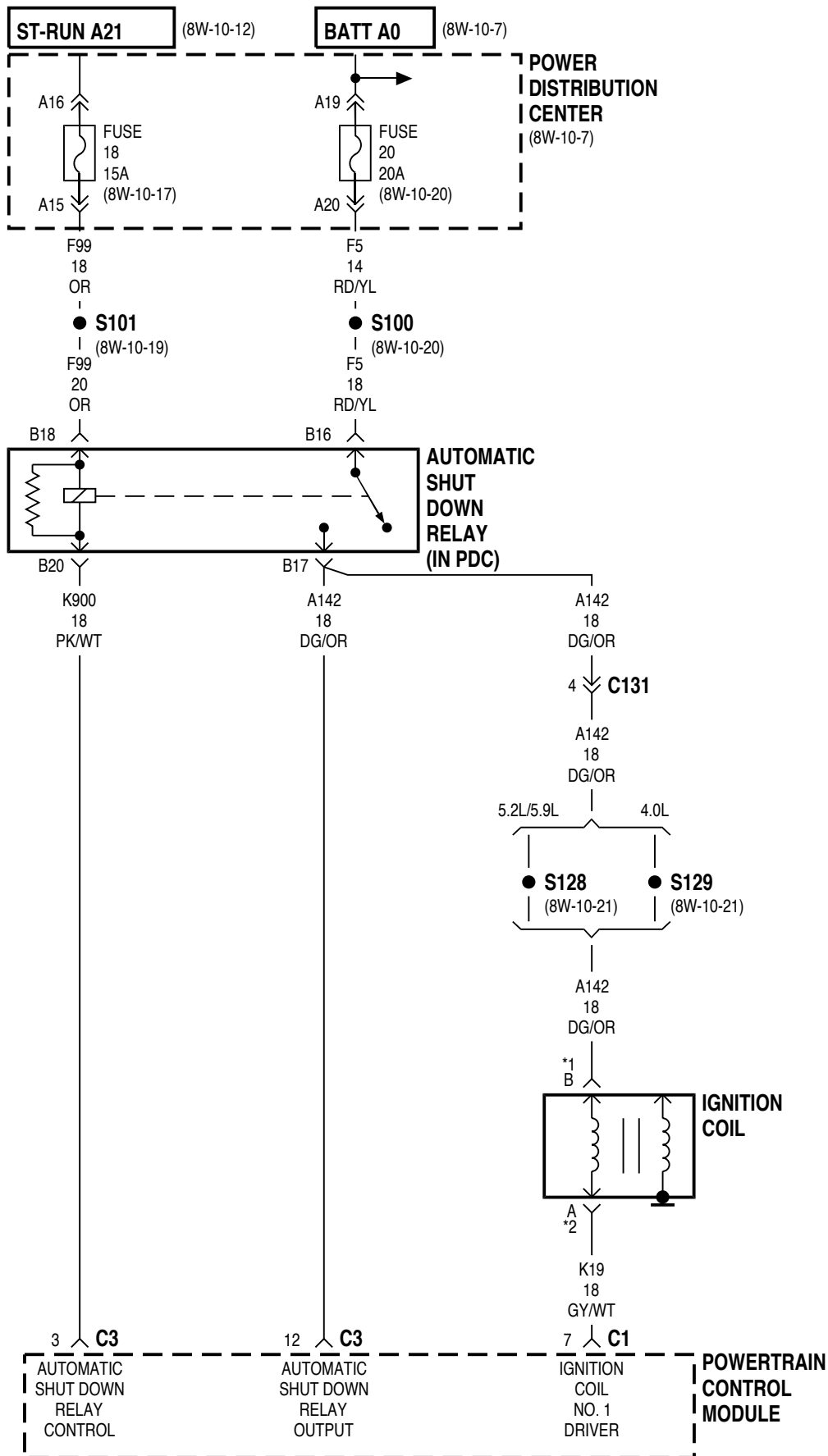




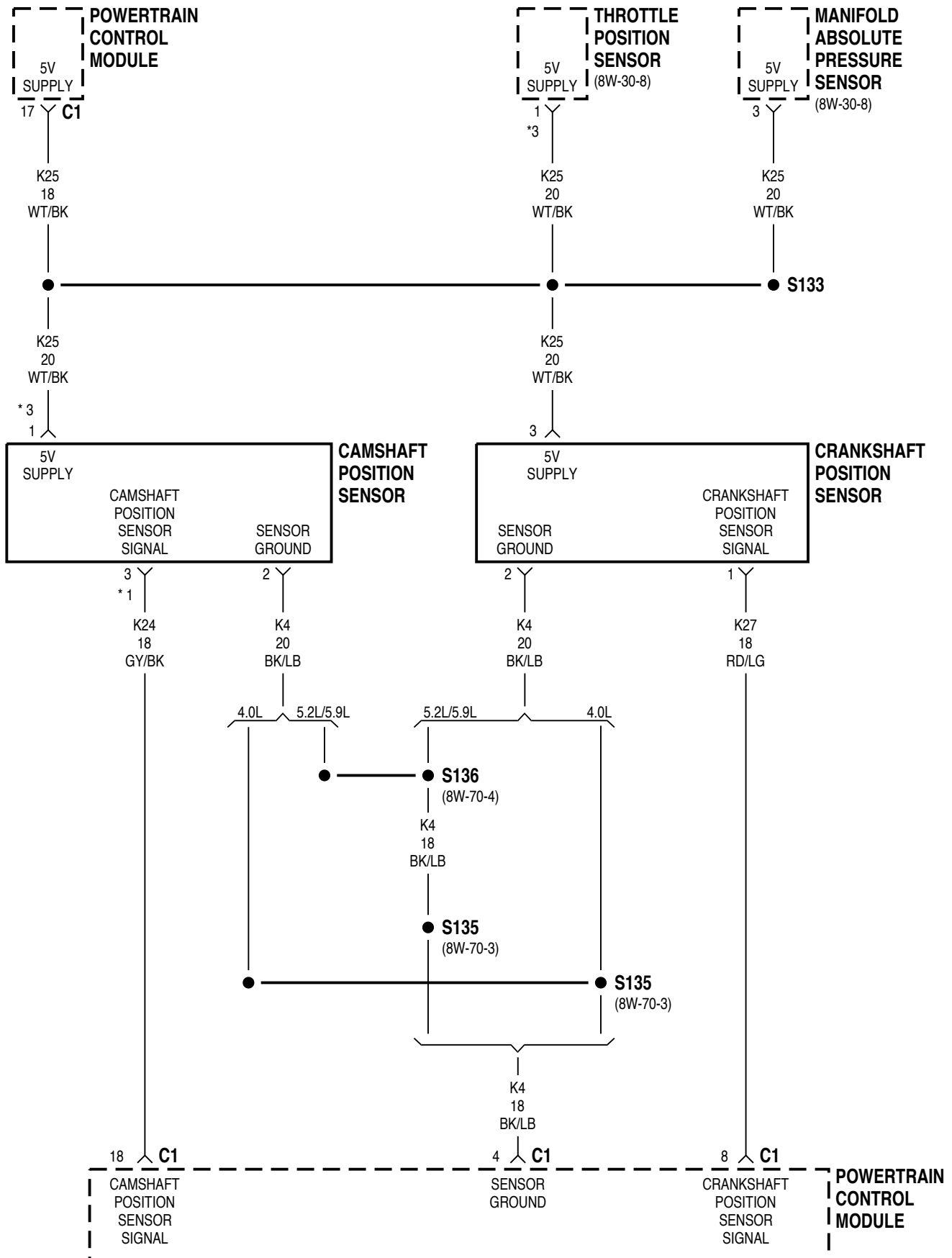
GAS

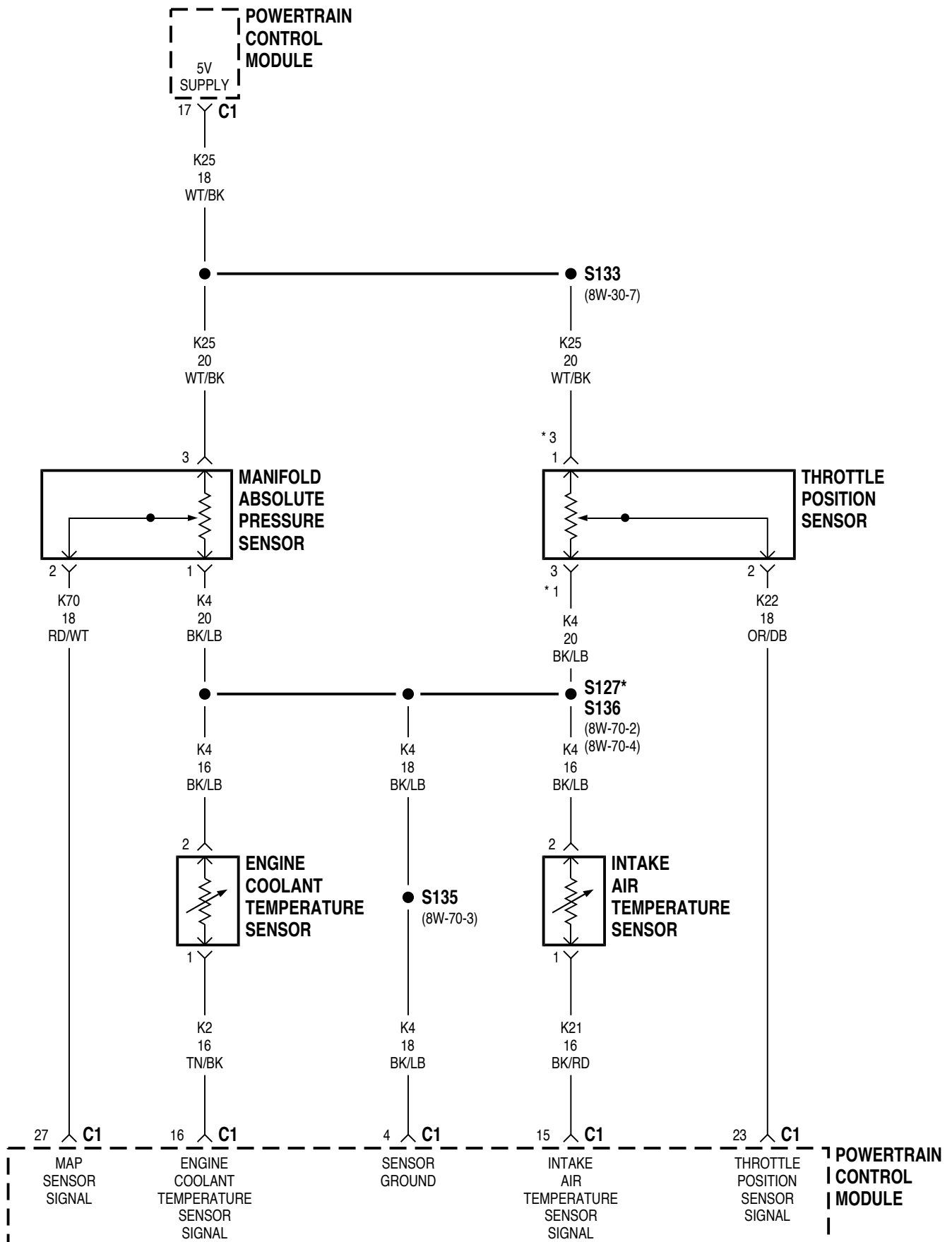


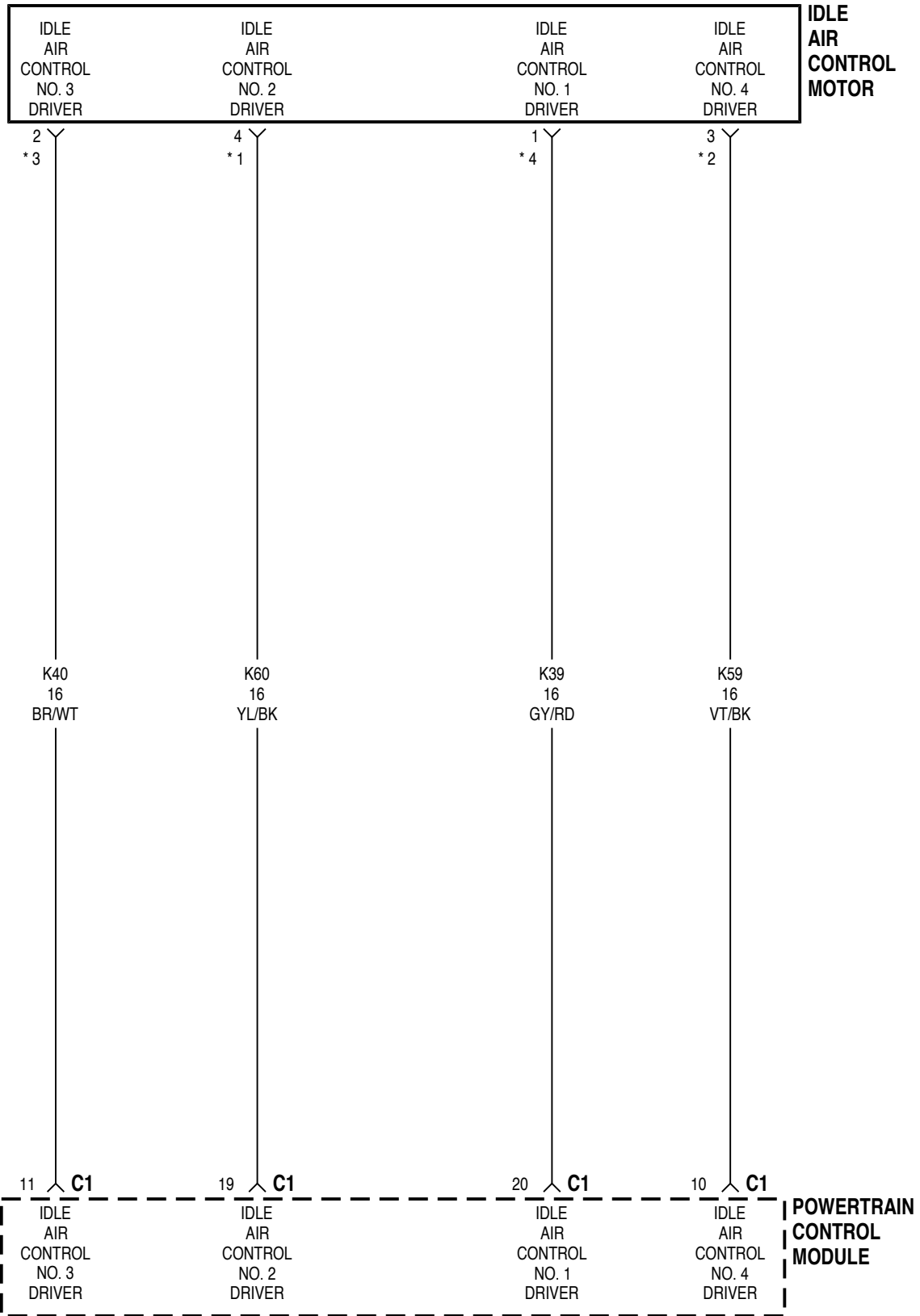
GAS



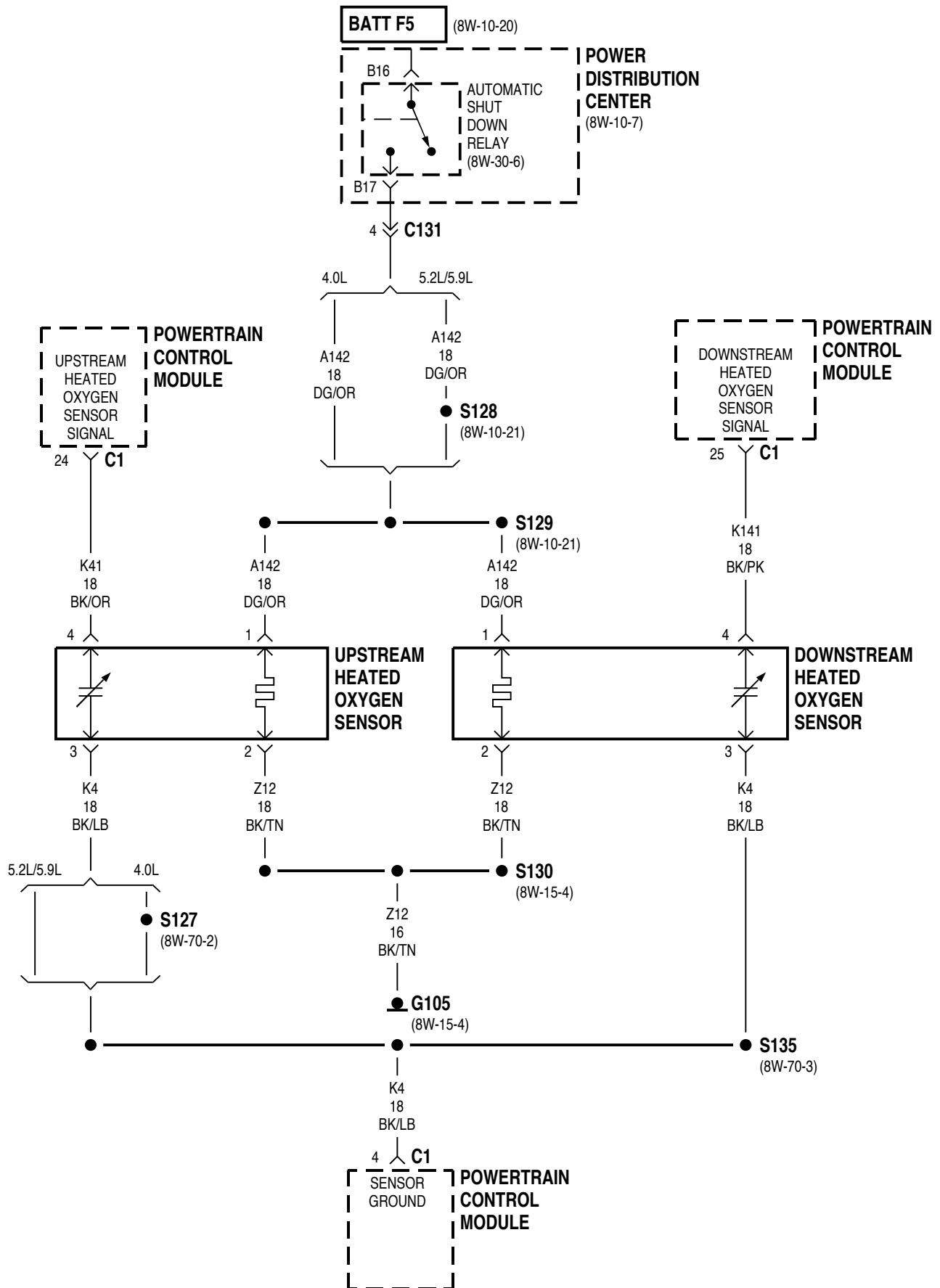
* 4.0L RHD

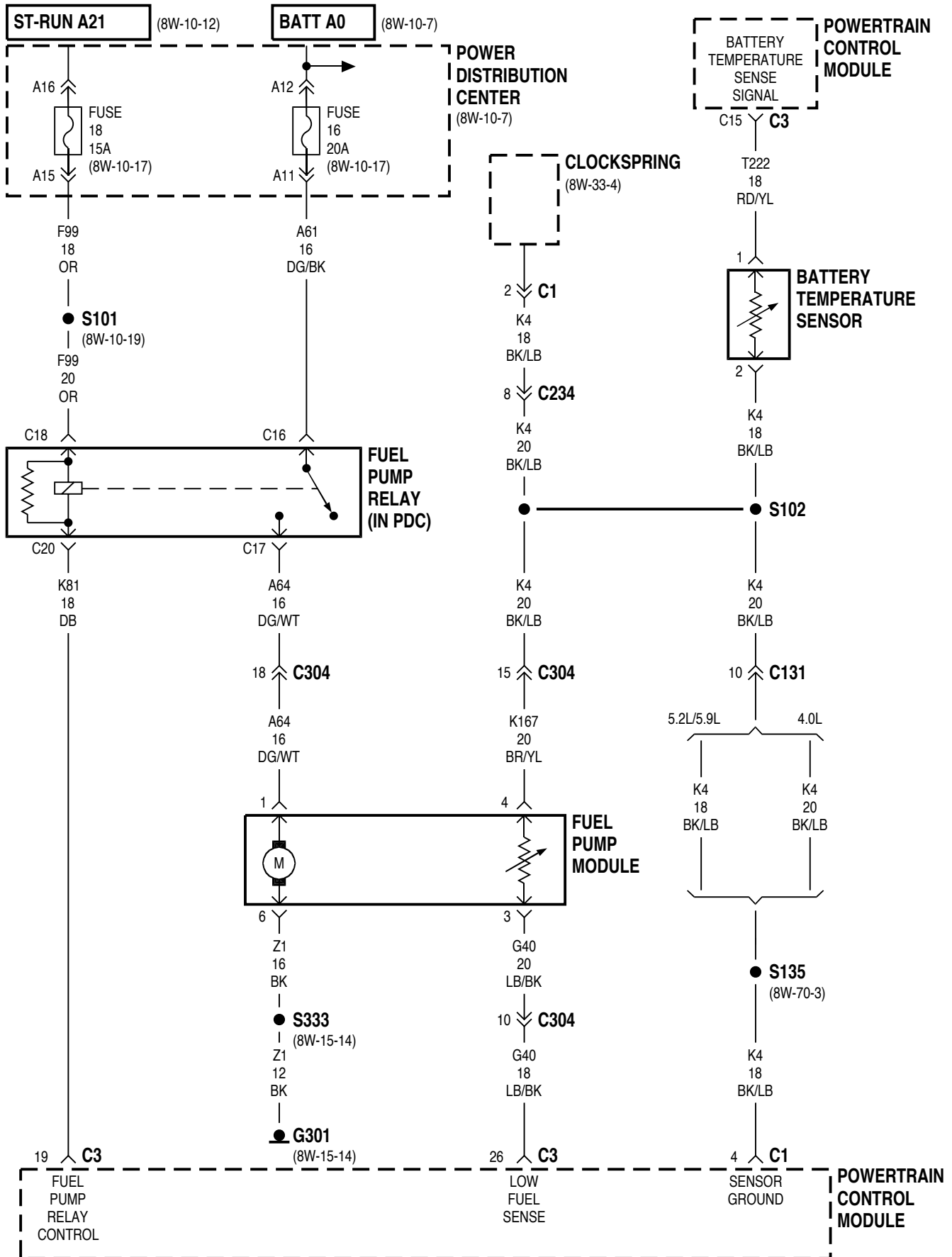


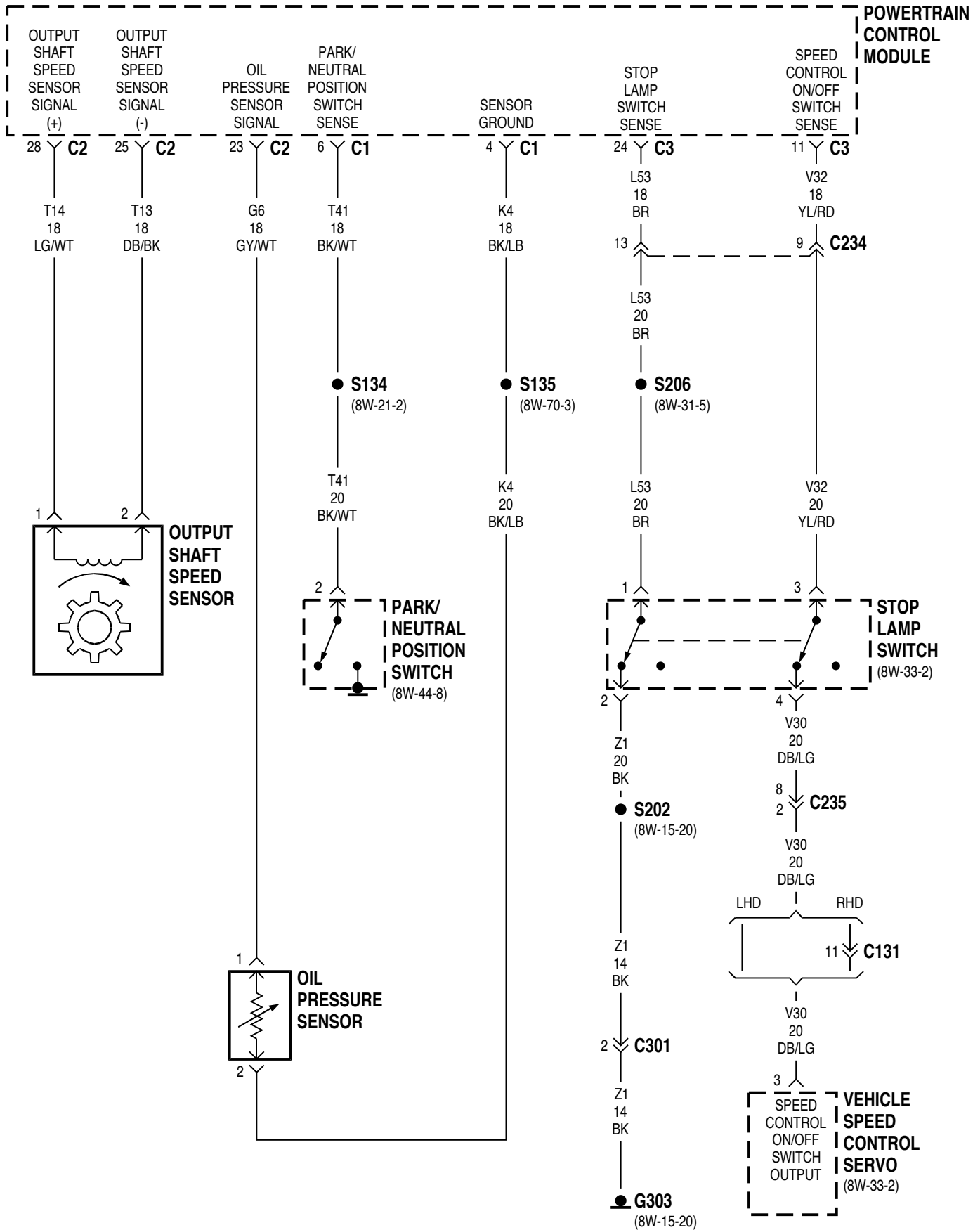




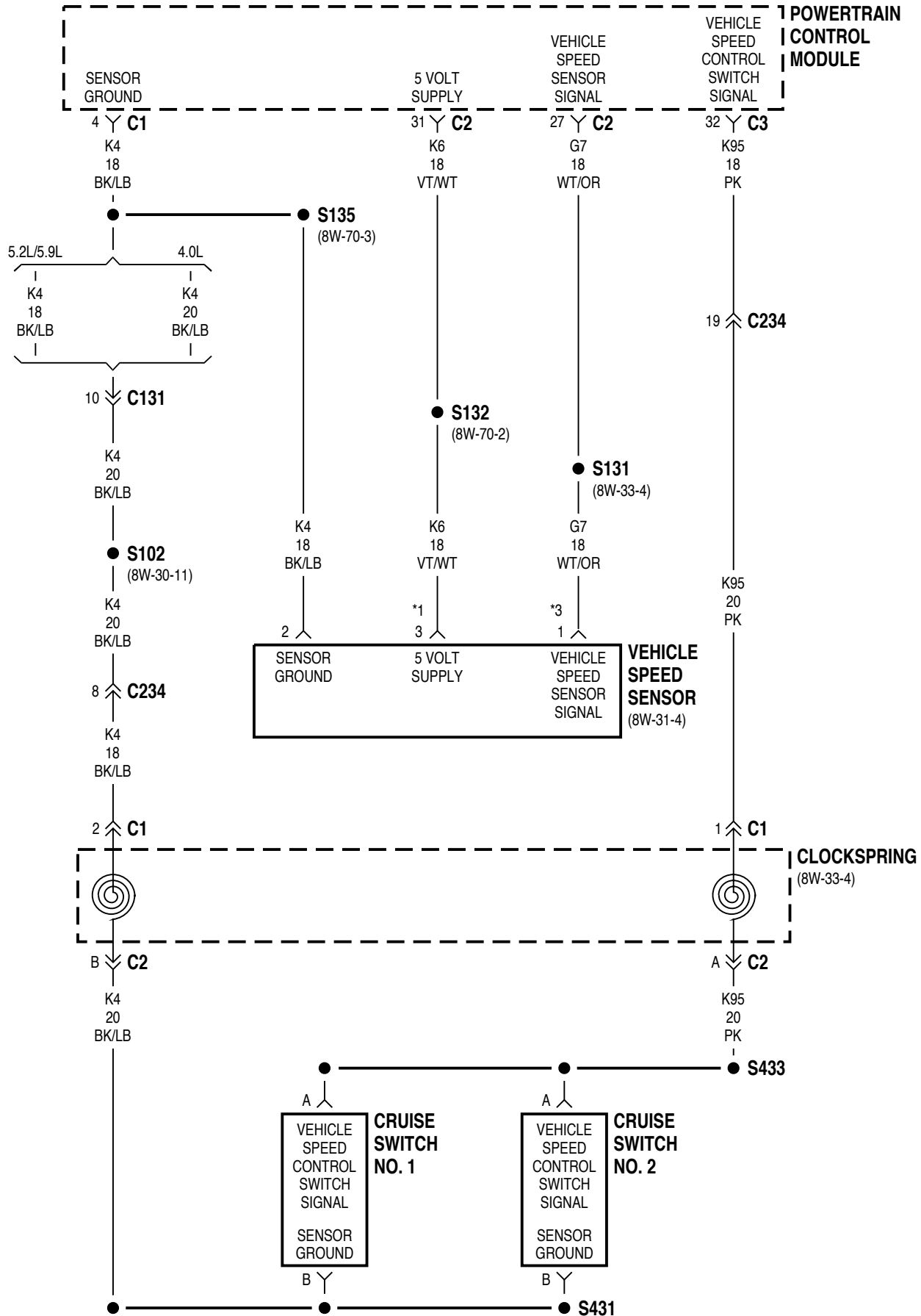
* 4.0L



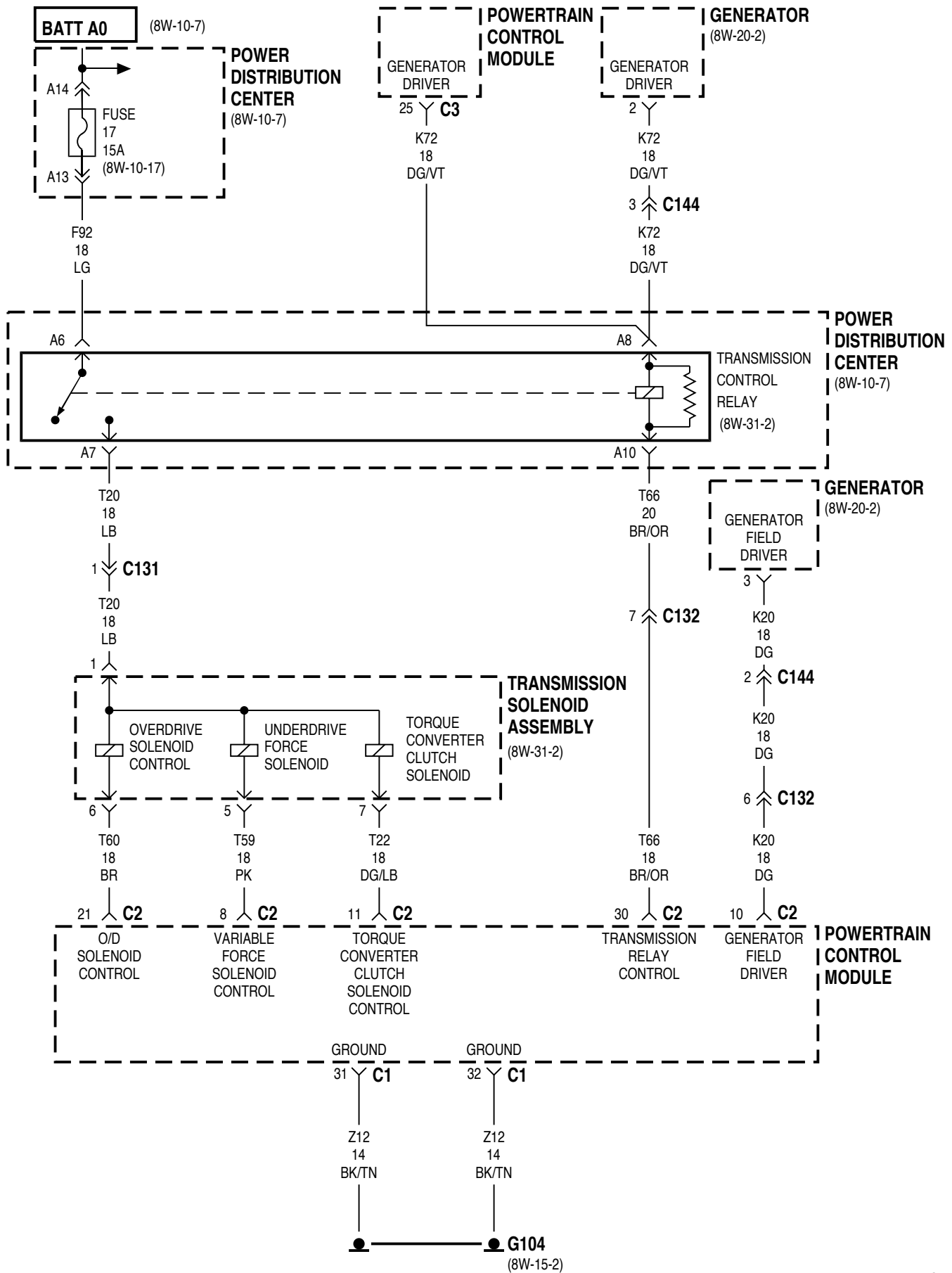


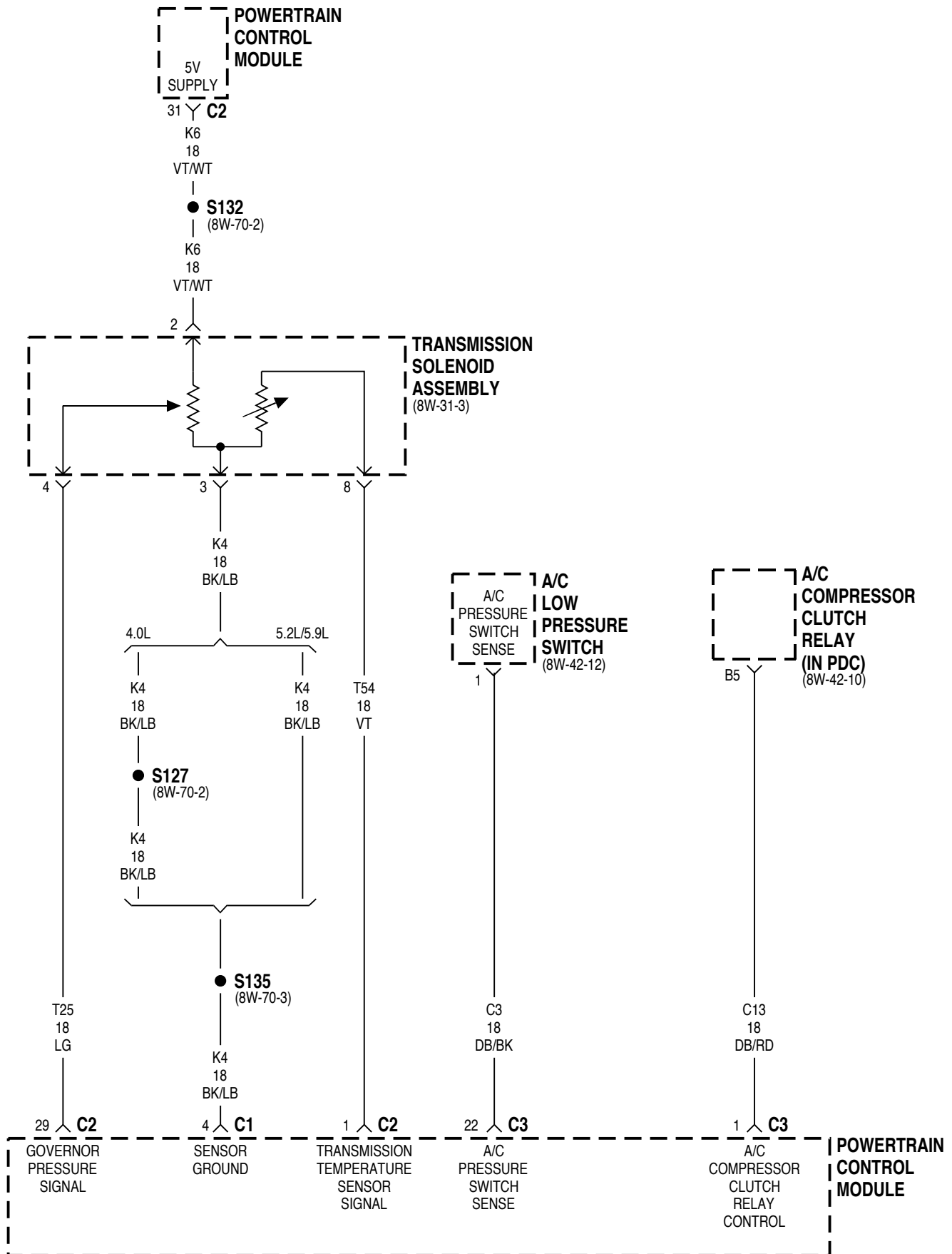


GAS

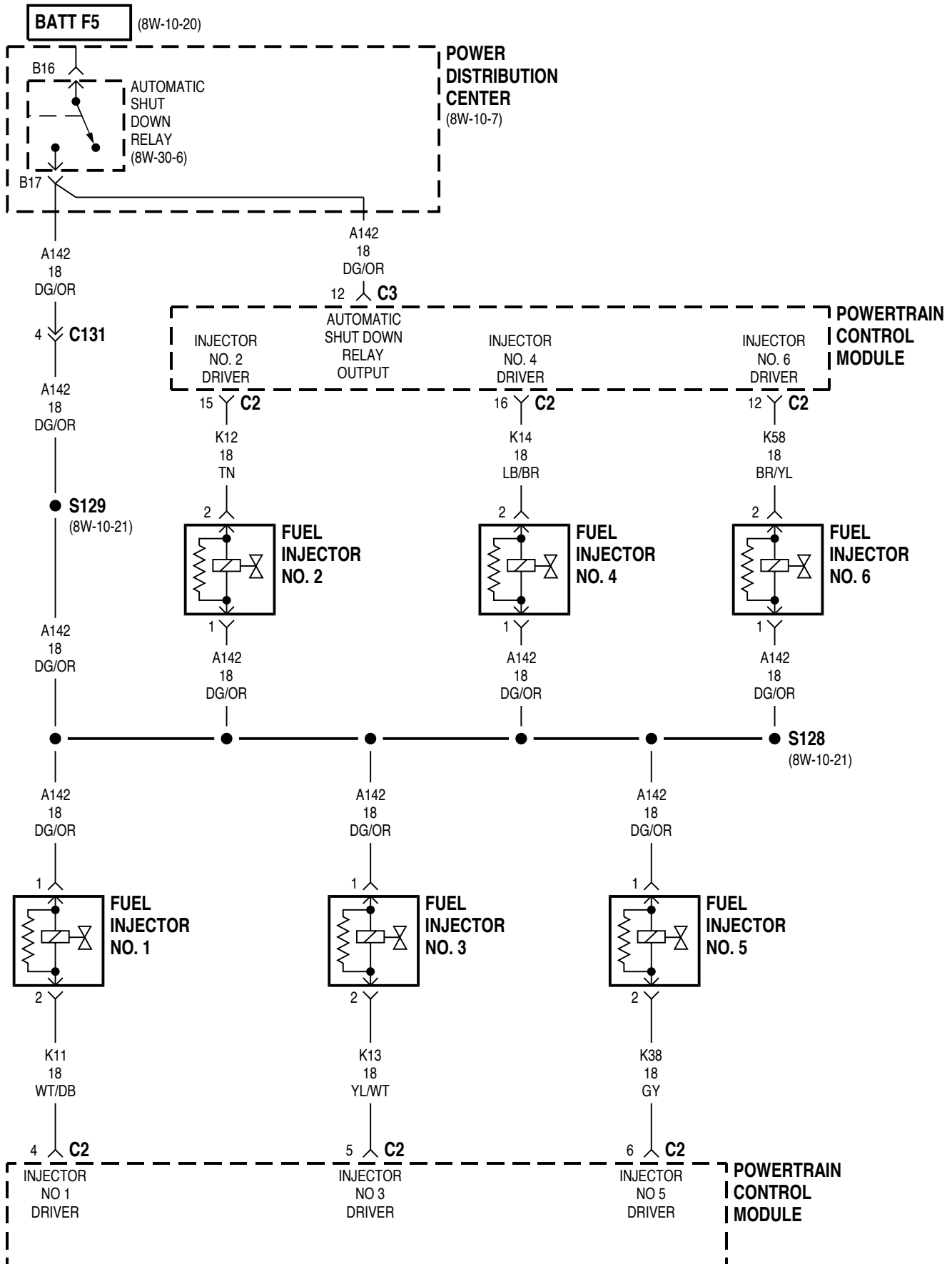


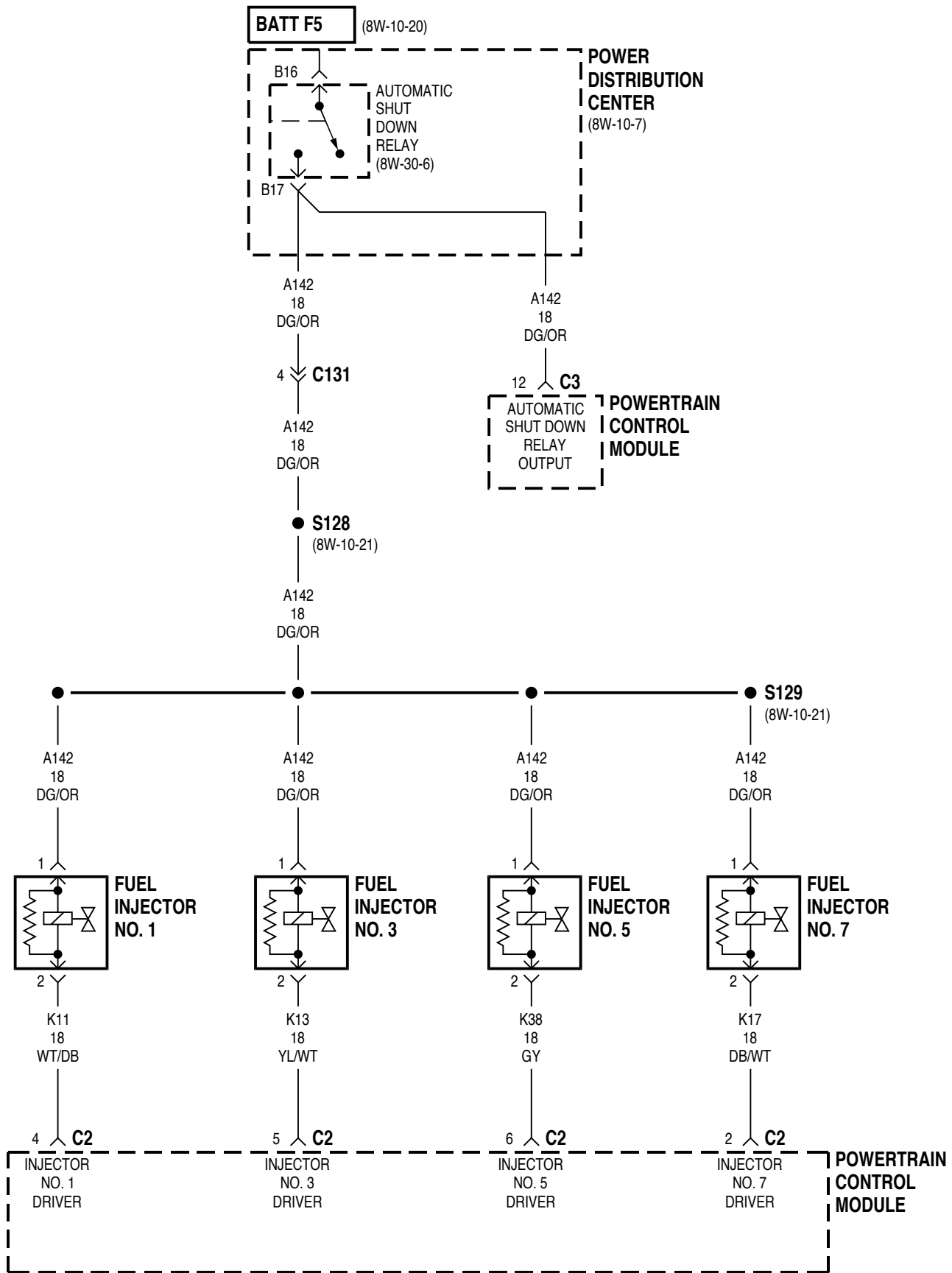
GAS

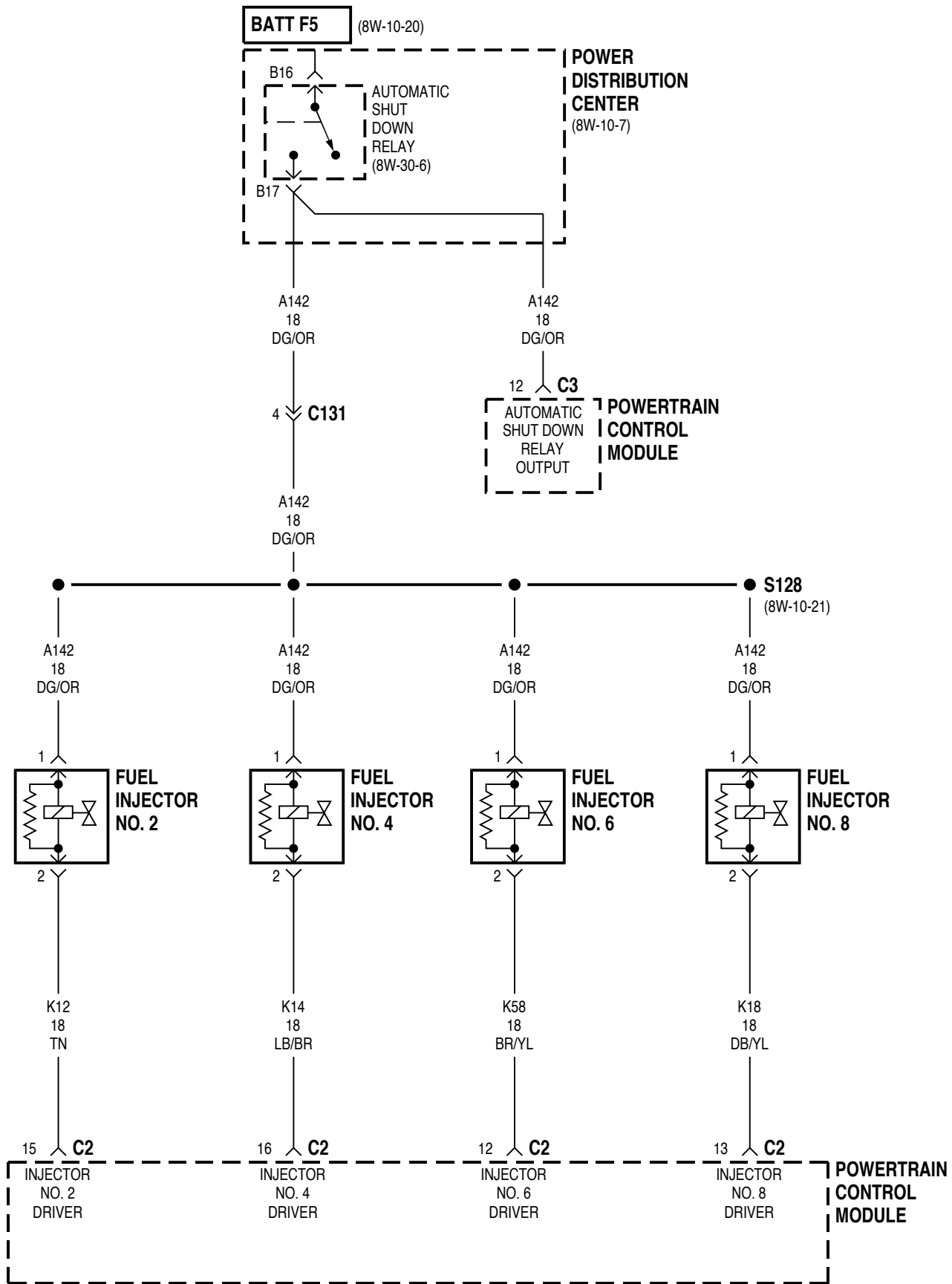


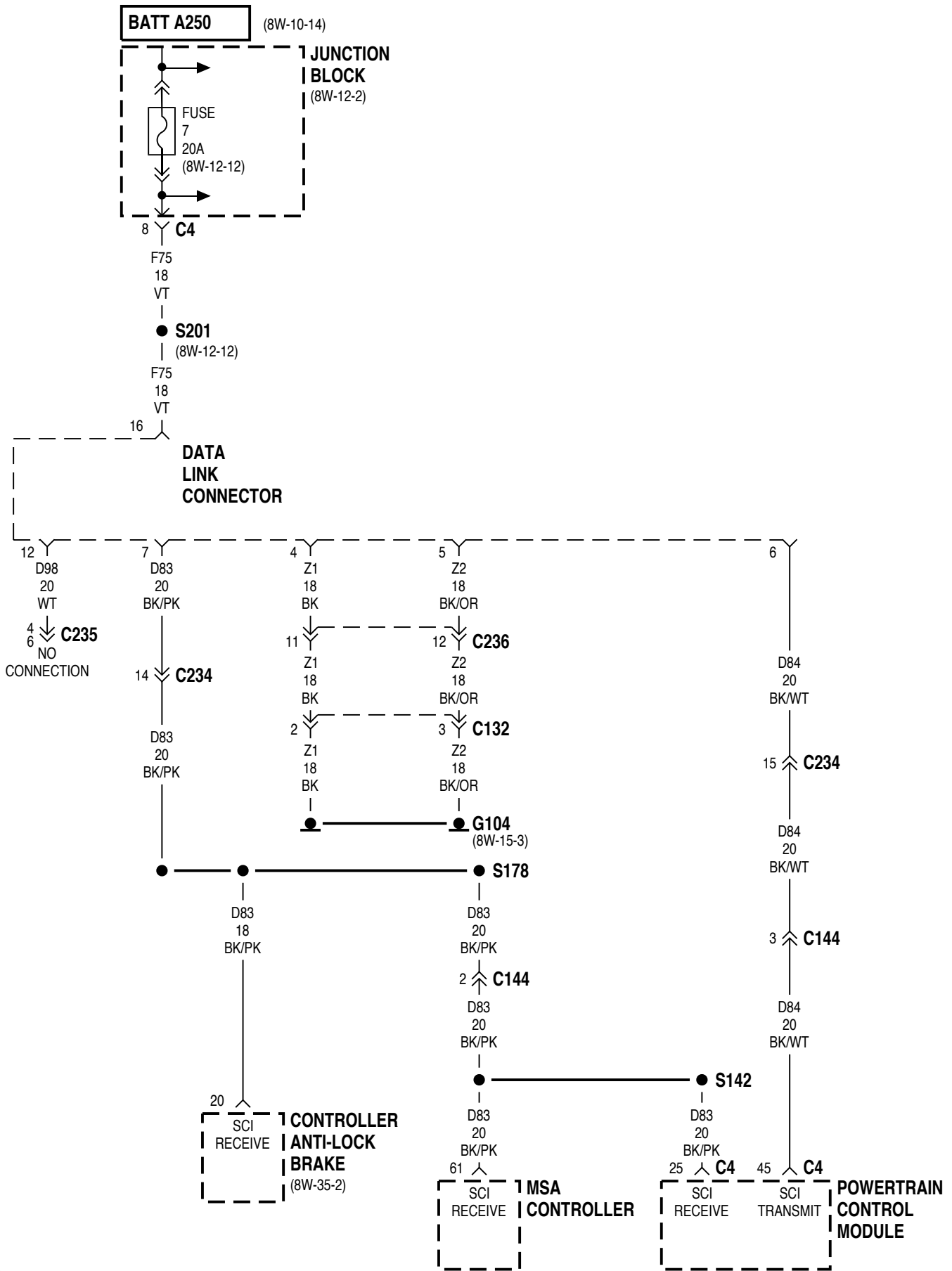


4.0L

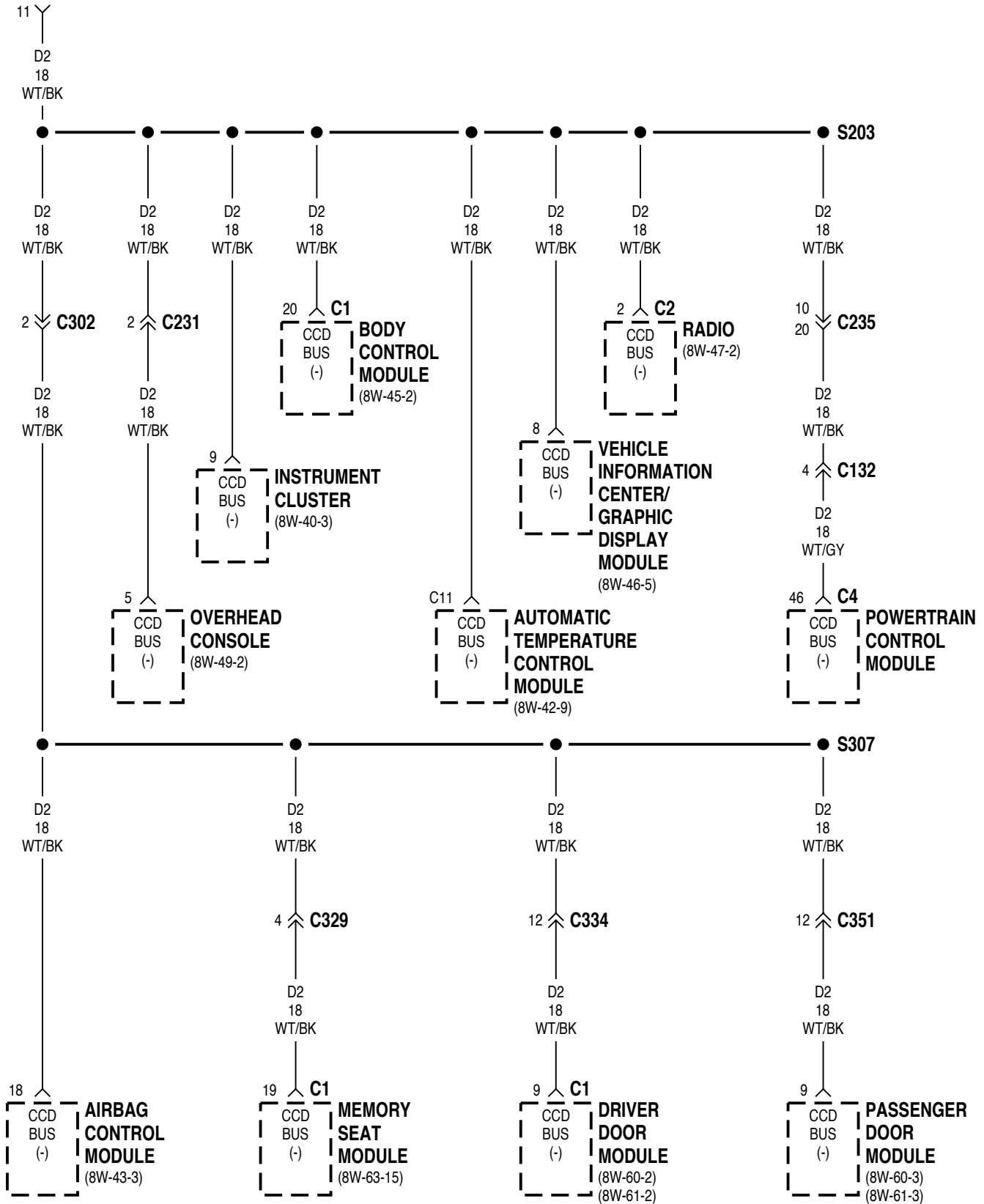


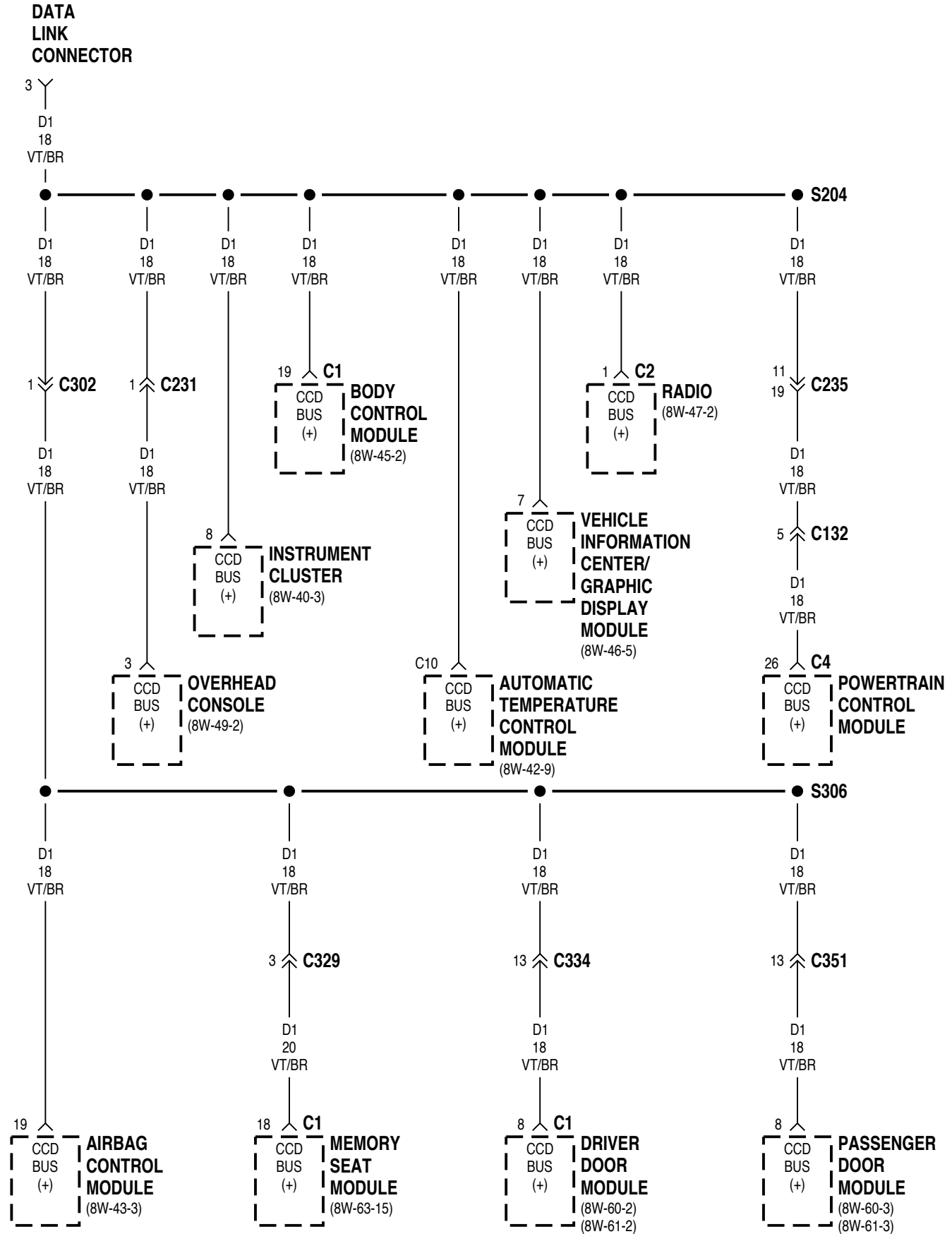


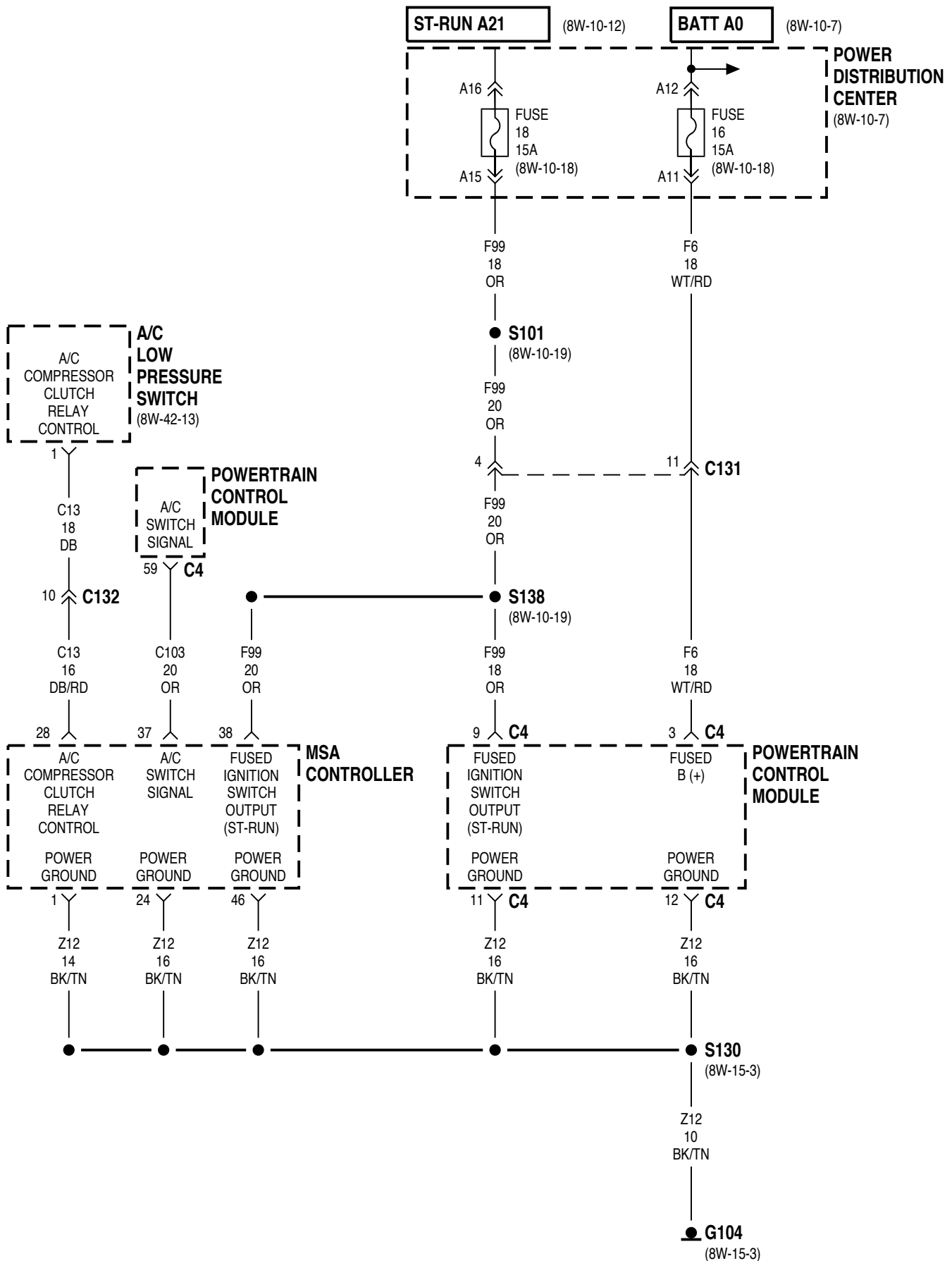


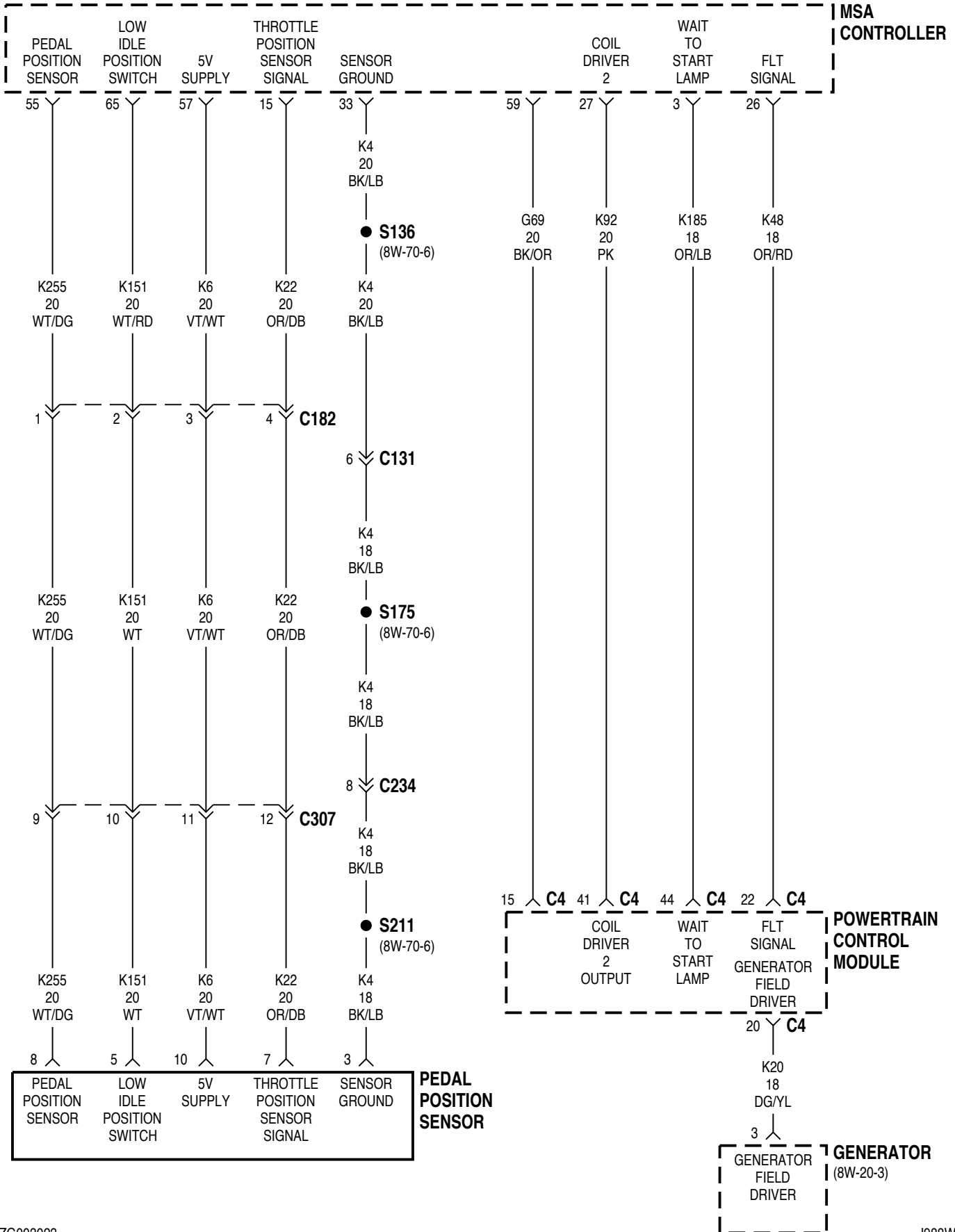


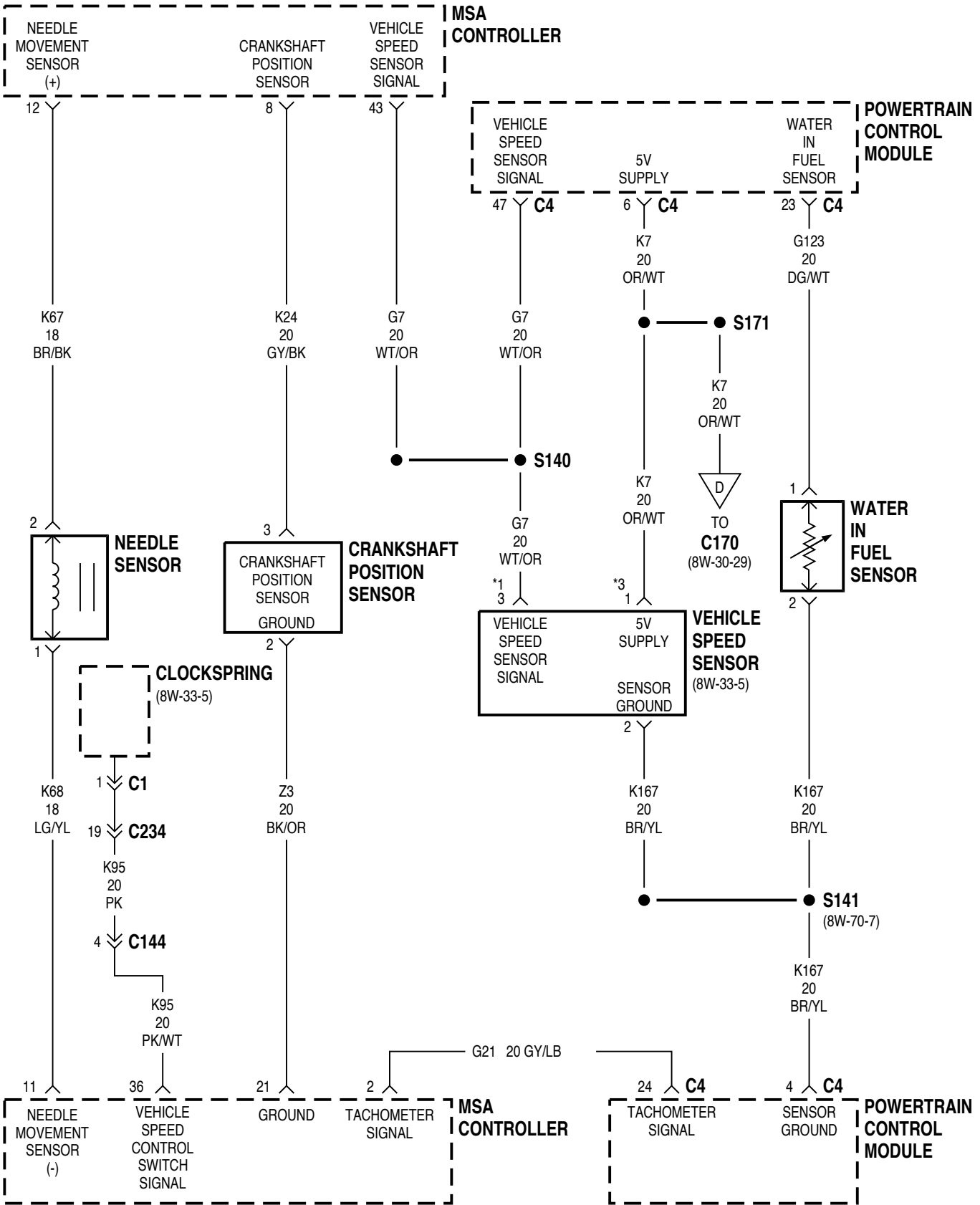
DATA
LINK
CONNECTOR

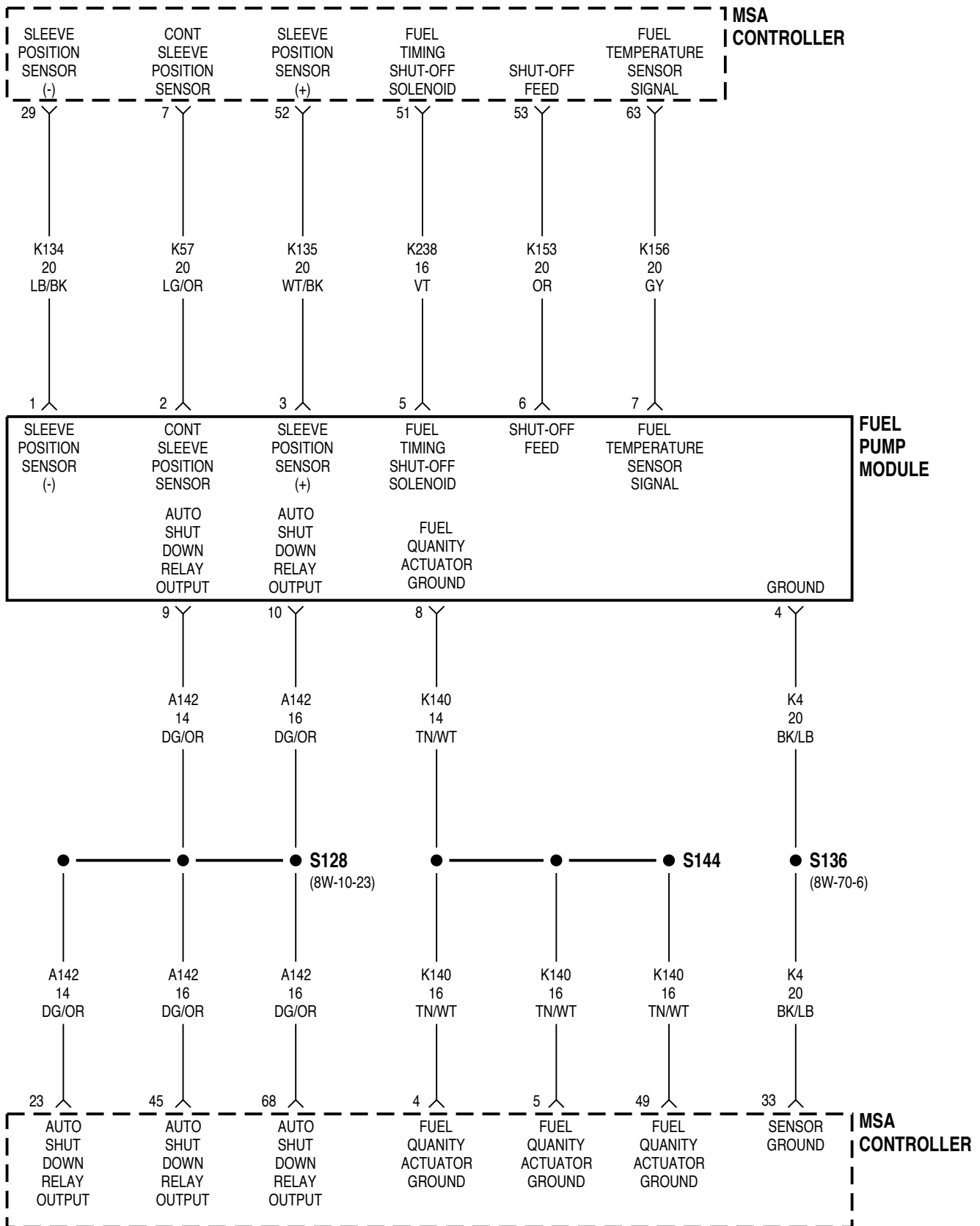


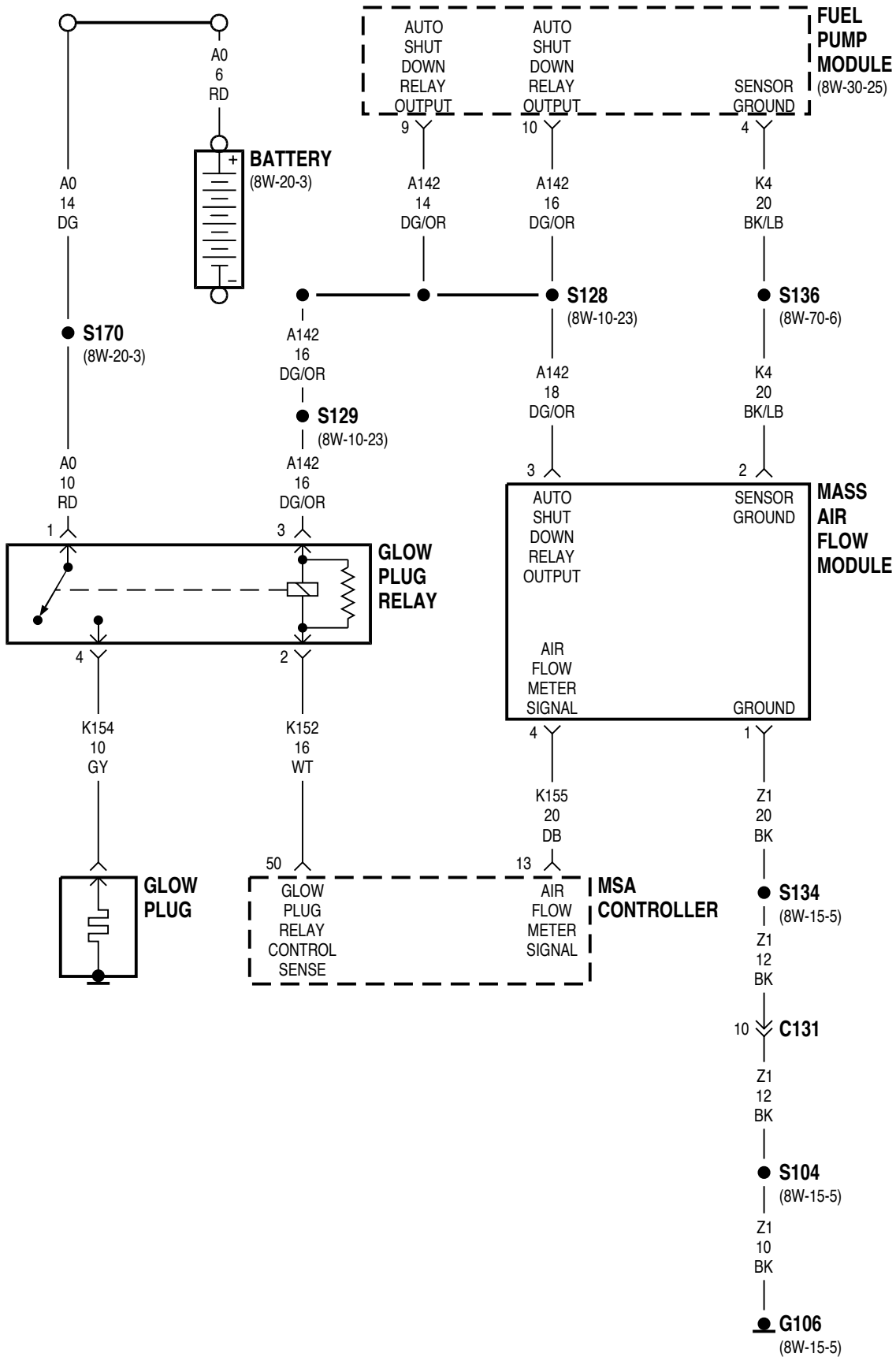




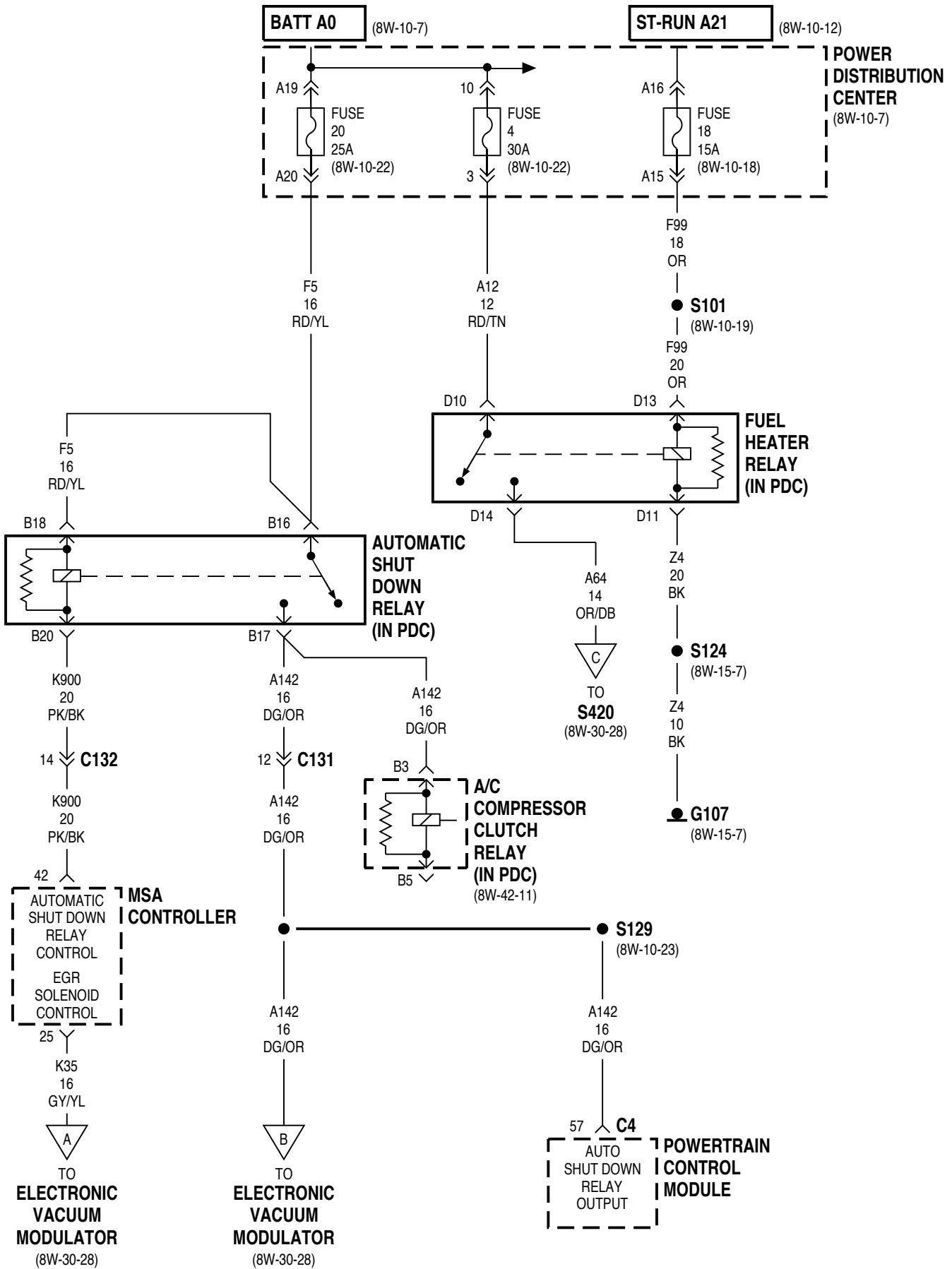


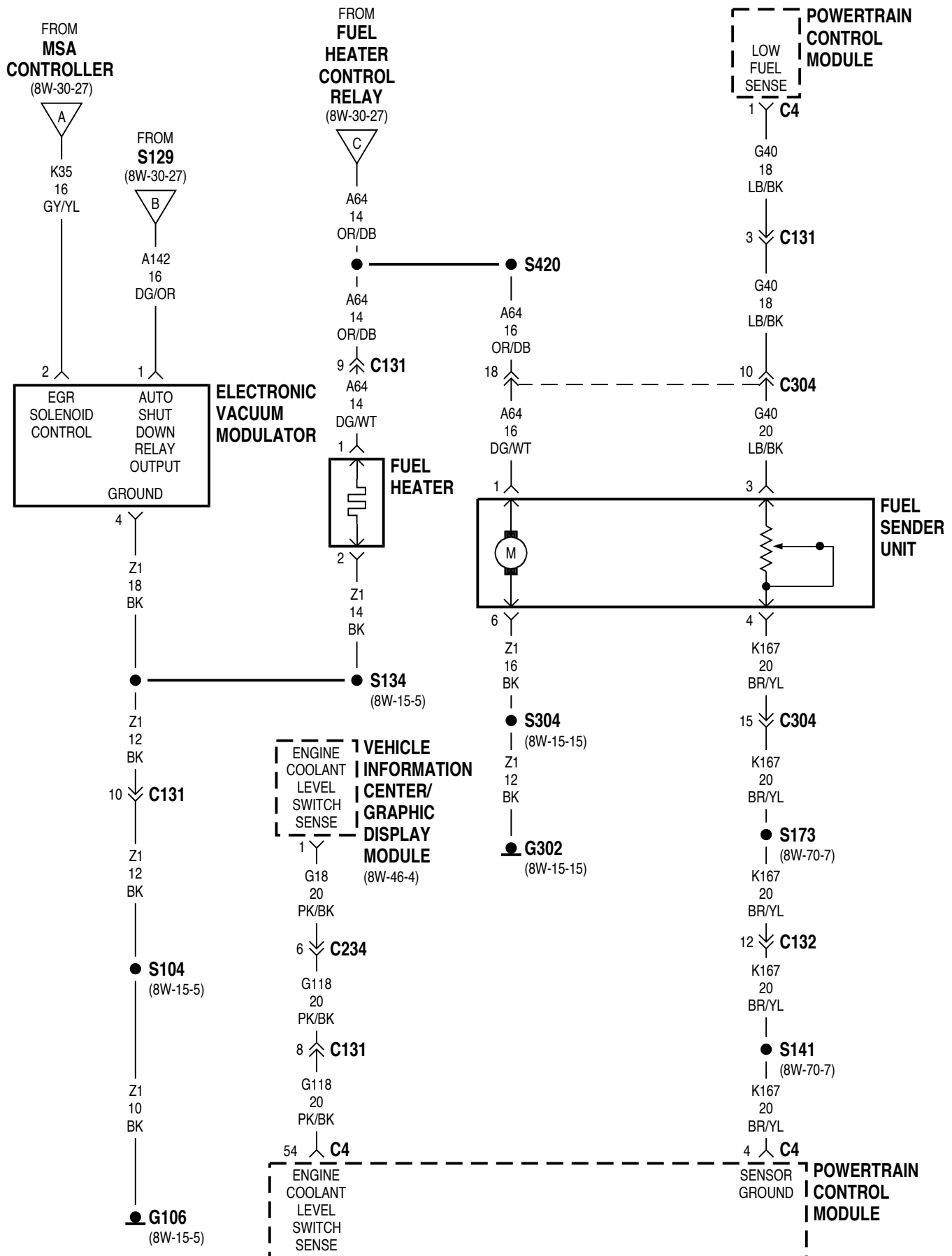




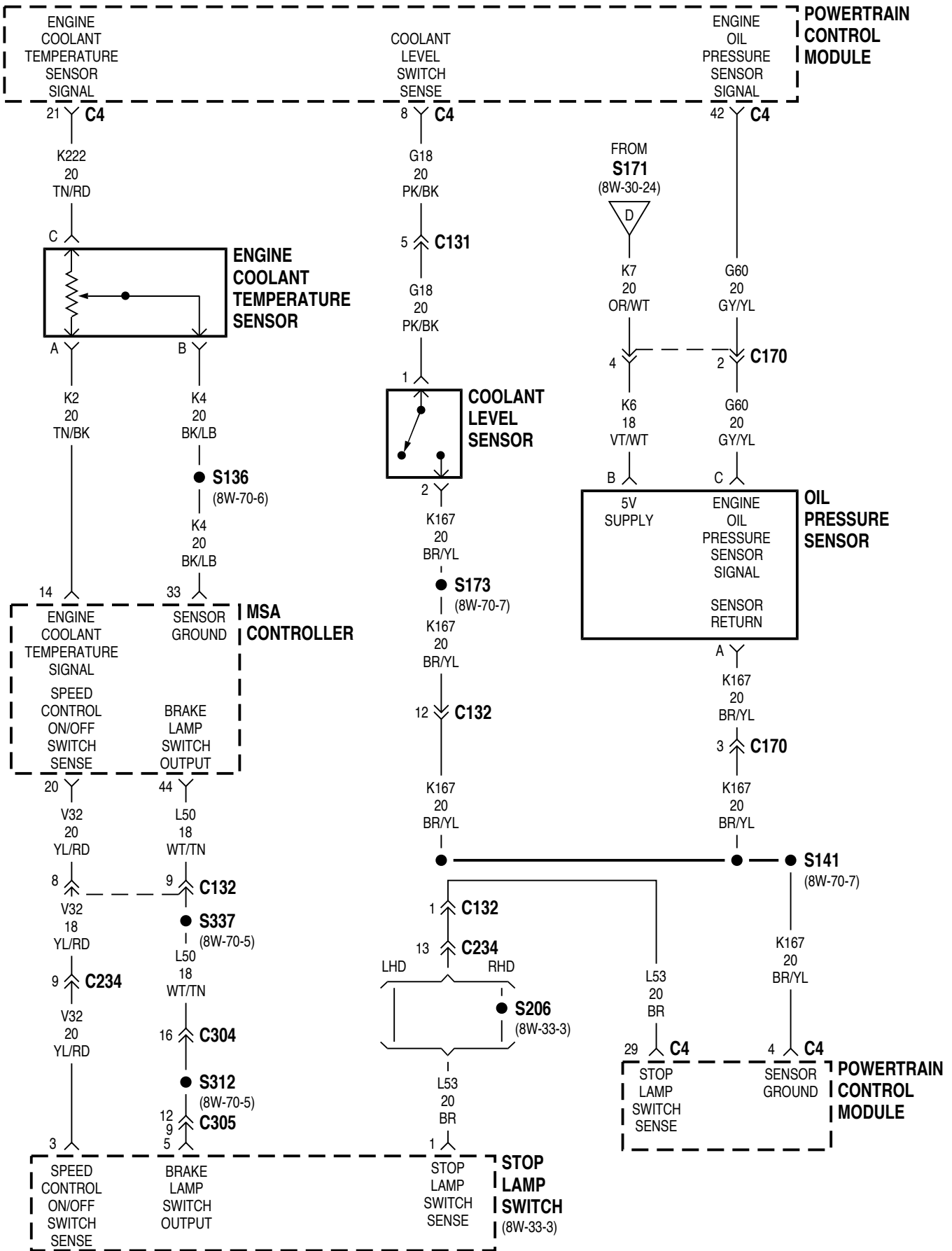


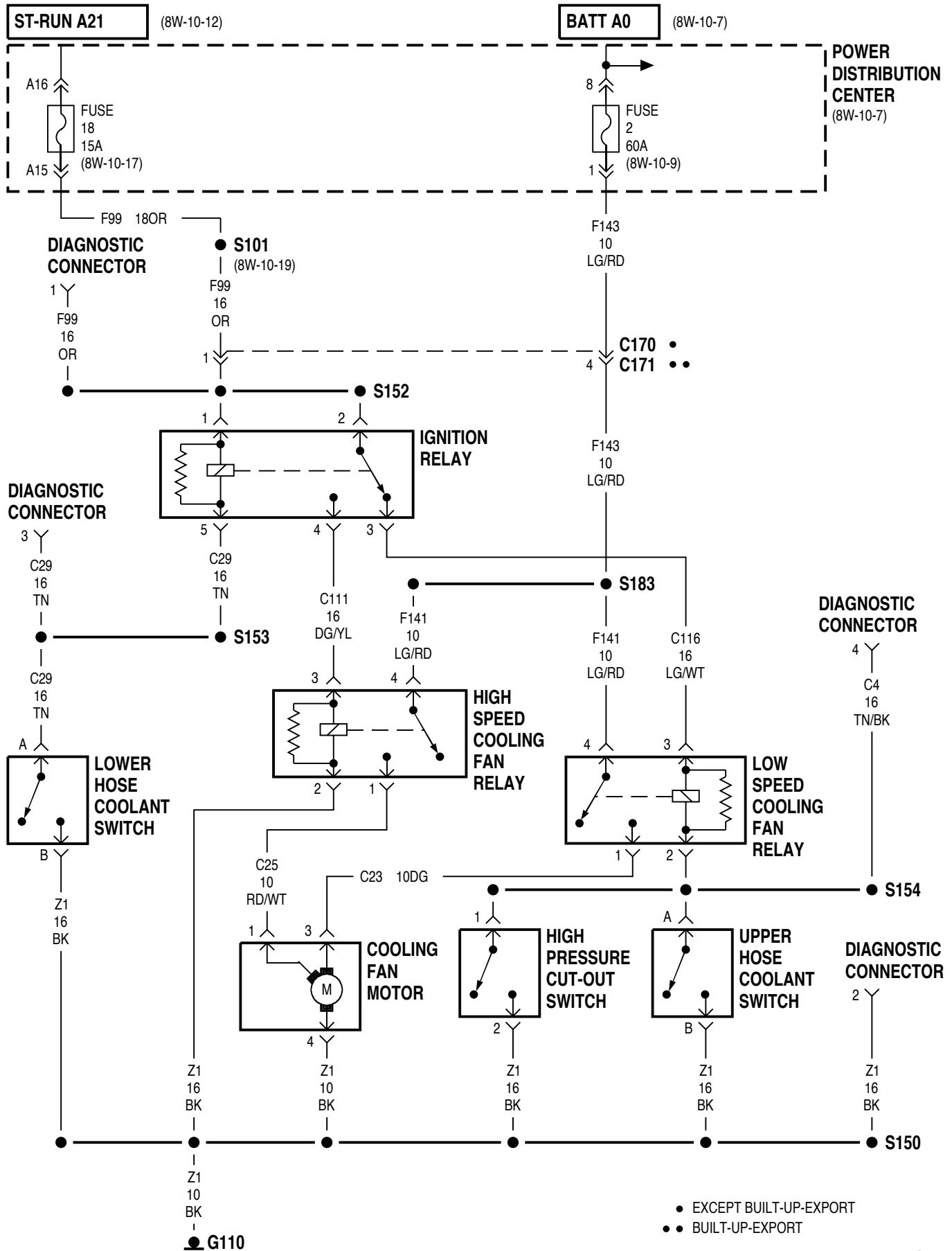
DIESEL

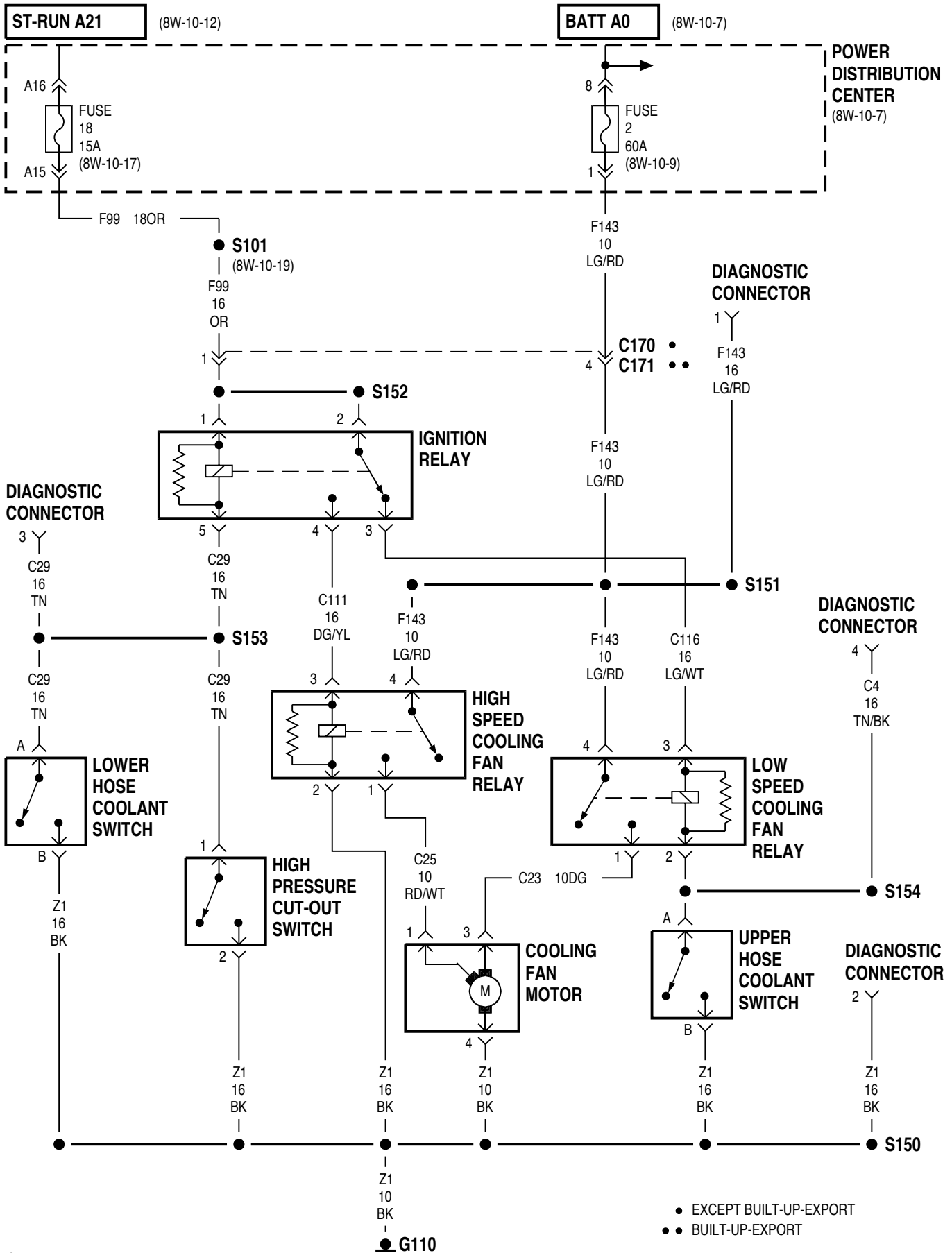




DIESEL

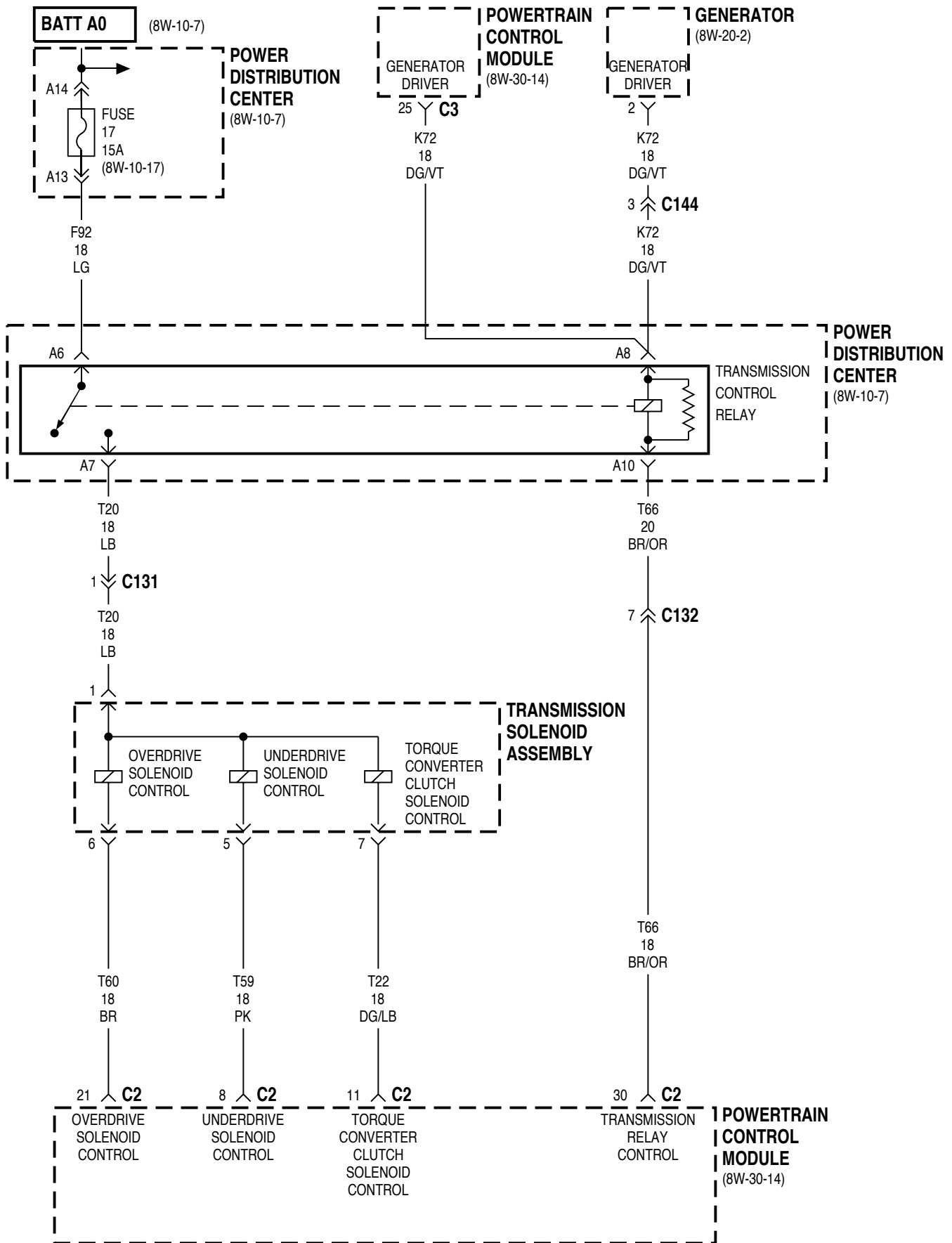


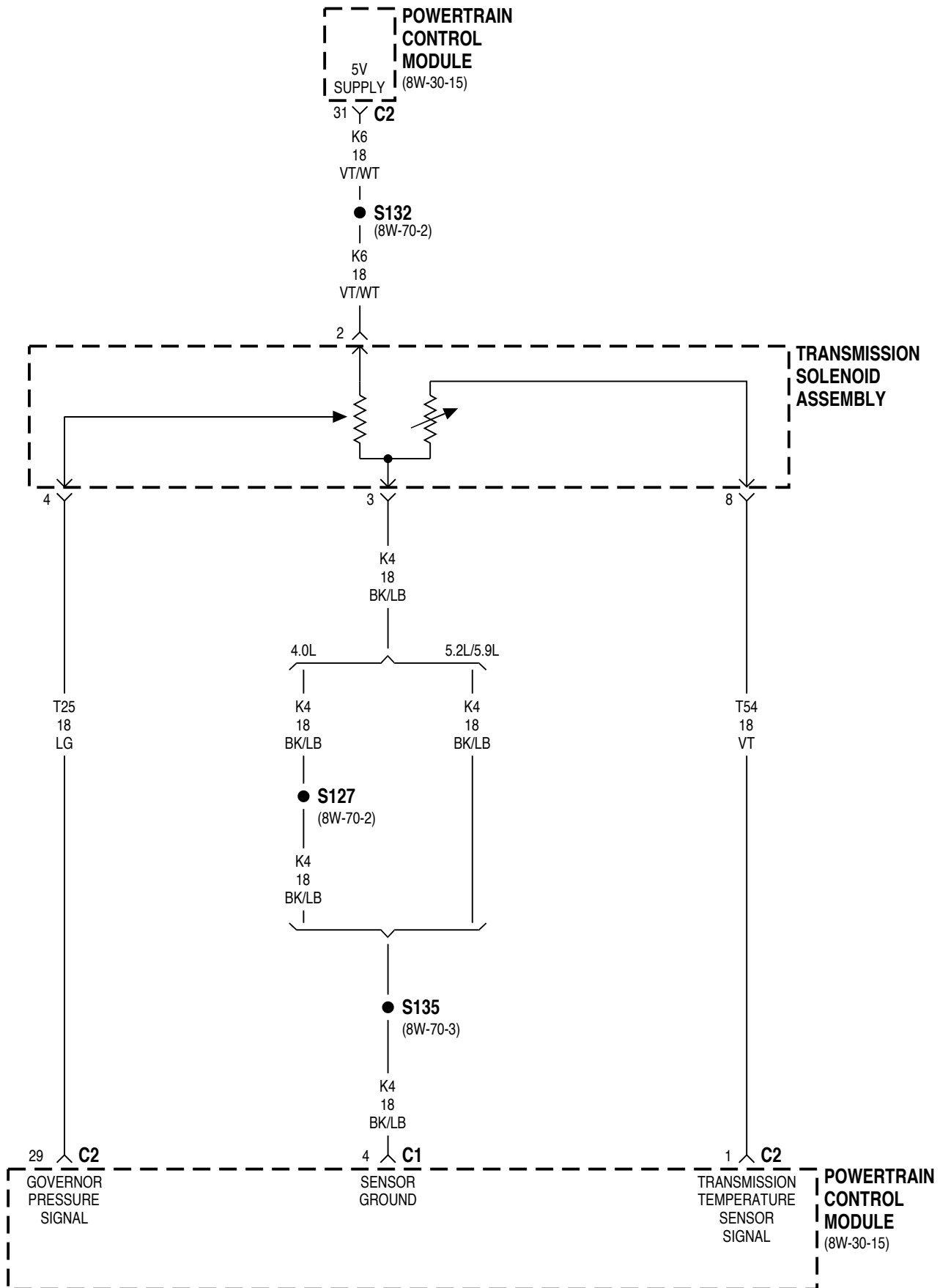


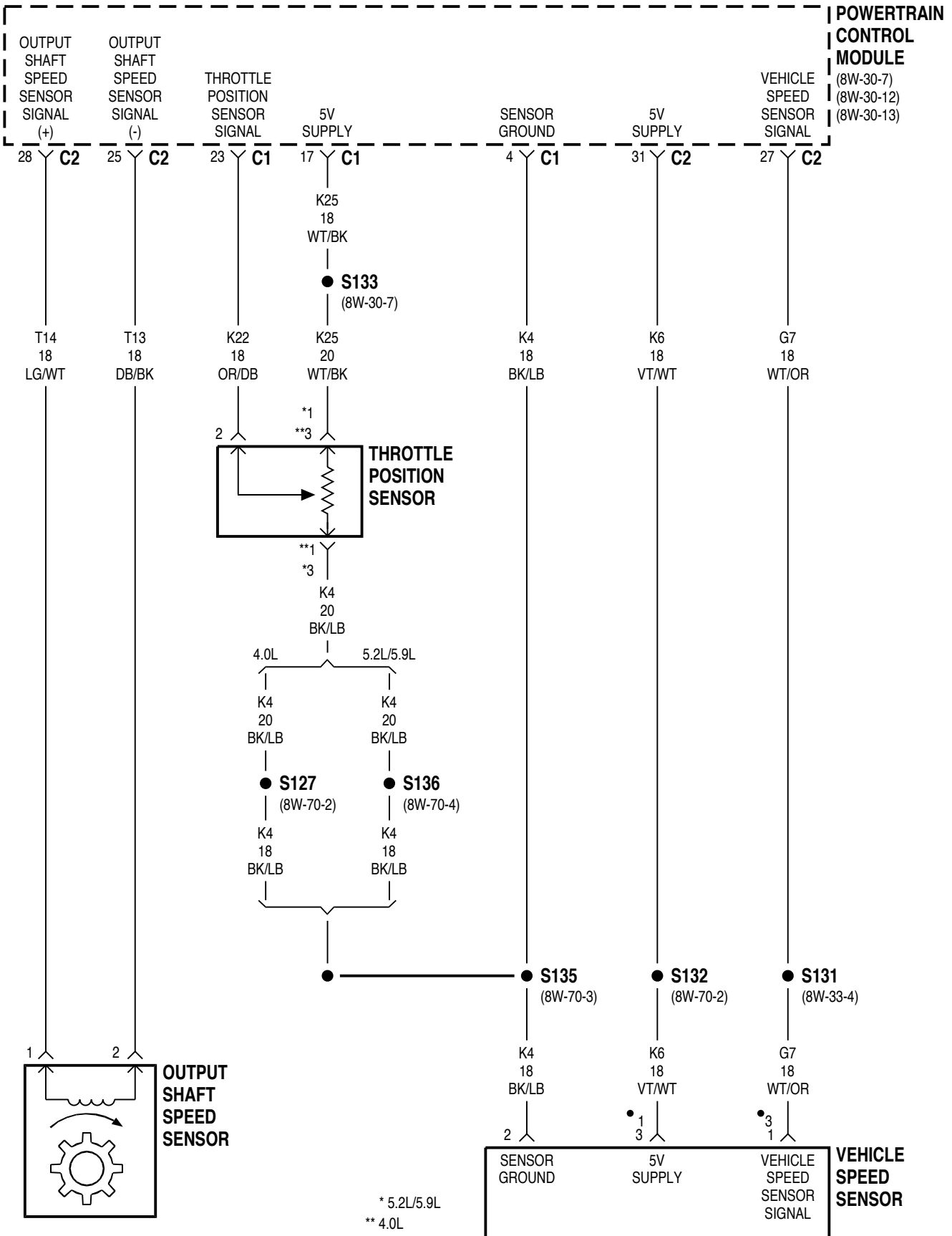


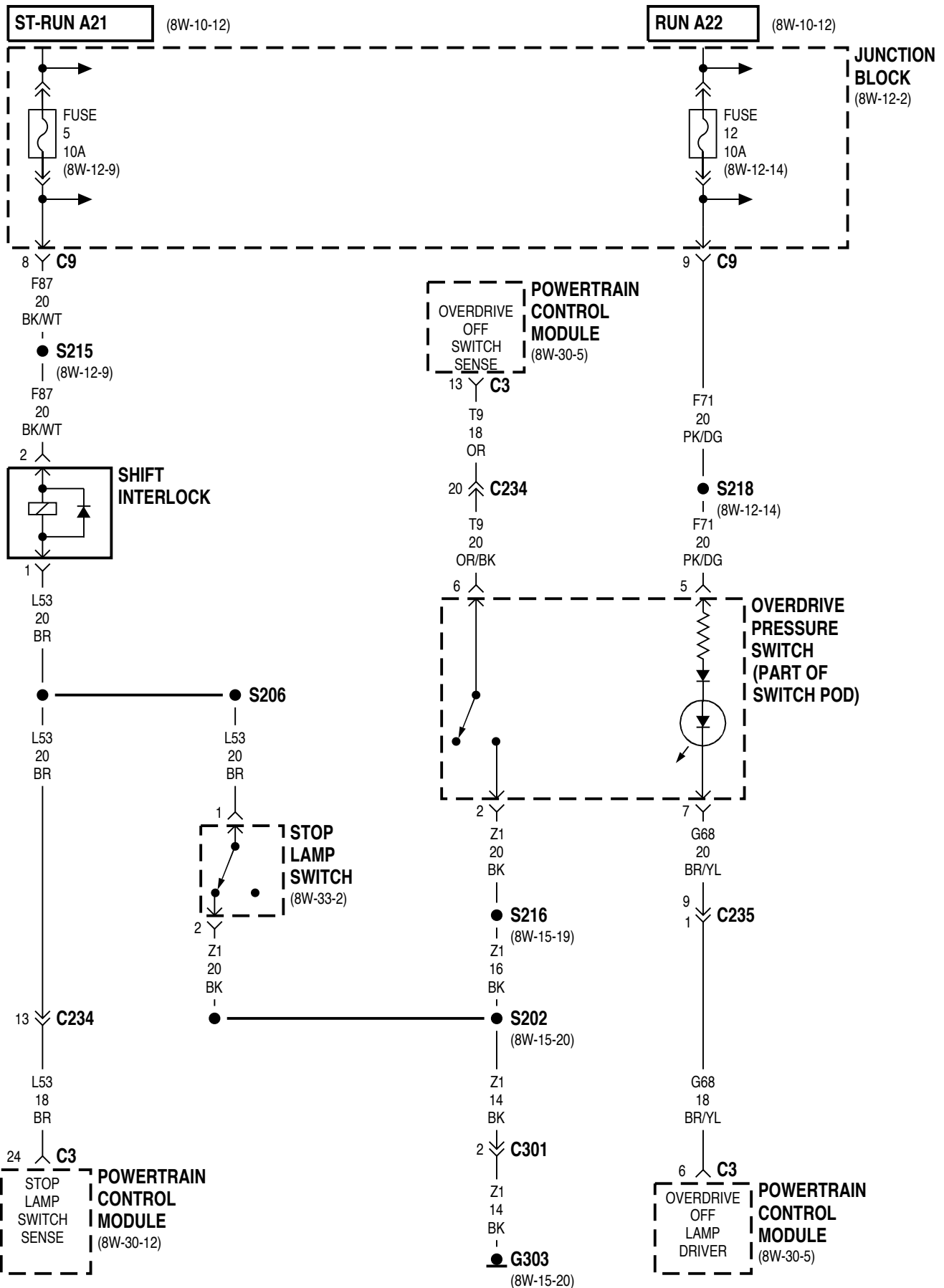
8W-31 TRANSMISSION CONTROL SYSTEM

Component	Page	Component	Page
Fuse 5 (JB)8W-31-5	Powertrain Control Module8W-31-2, 3, 4, 5
Fuse 12 (JB)8W-31-5	Shift Interlock8W-31-5
Fuse 17 (PDC)8W-31-2	Stop Lamp Switch8W-31-5
G3038W-31-5	Throttle Position Sensor8W-31-4
Generator8W-31-2	Torque Converter Clutch Solenoid Control8W-31-2
Junction Block8W-31-5	Transmission Control Relay8W-31-2
Output Shaft Speed Sensor8W-31-4	Transmission Solenoid Assembly8W-31-2, 3
Overdrive Pressure Switch8W-31-5	Underdrive Solenoid Control8W-31-2
Overdrive Solenoid Control8W-31-2	Vehicle Speed Sensor8W-31-4
Power Distribution Center8W-31-2		



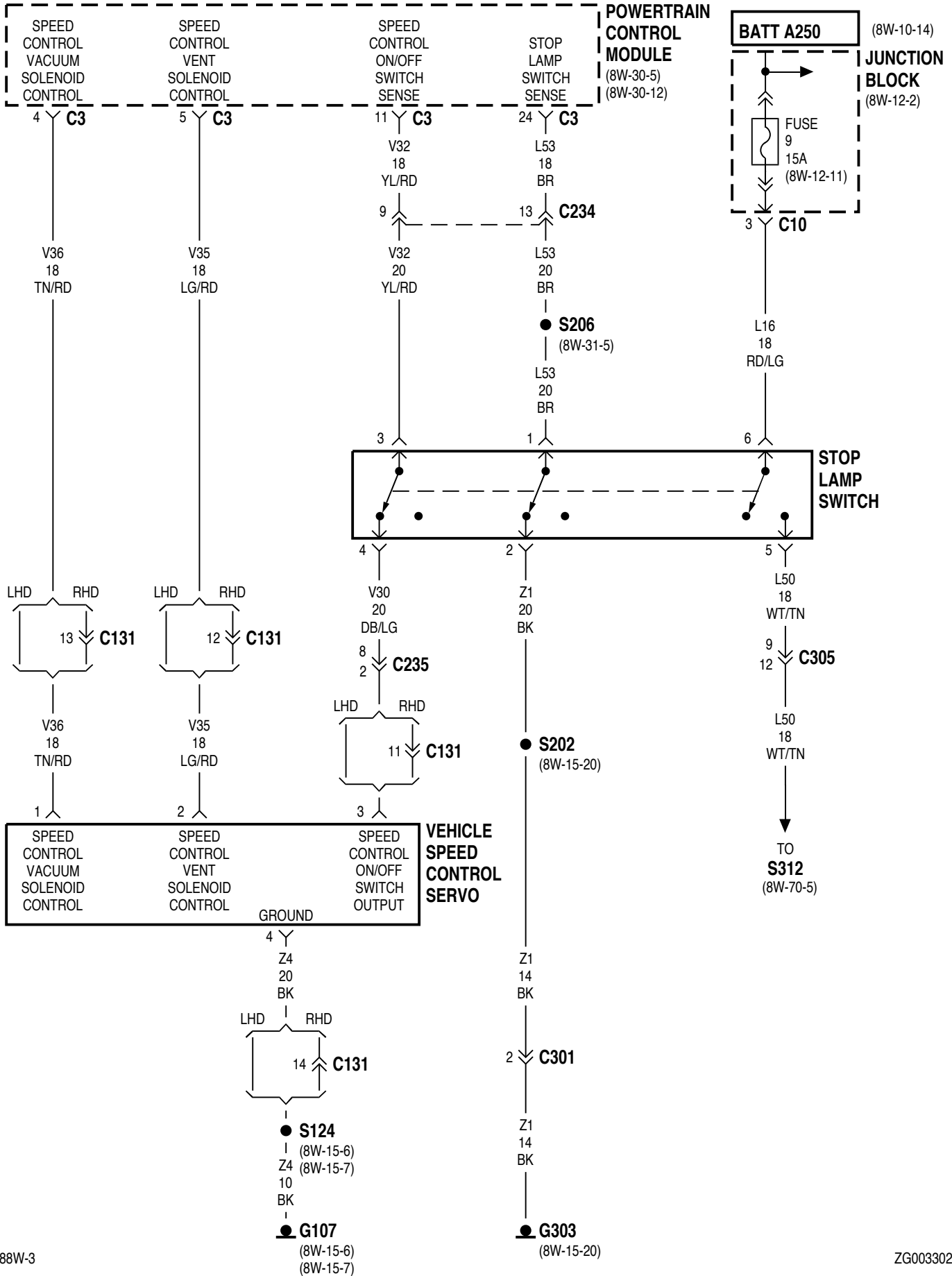


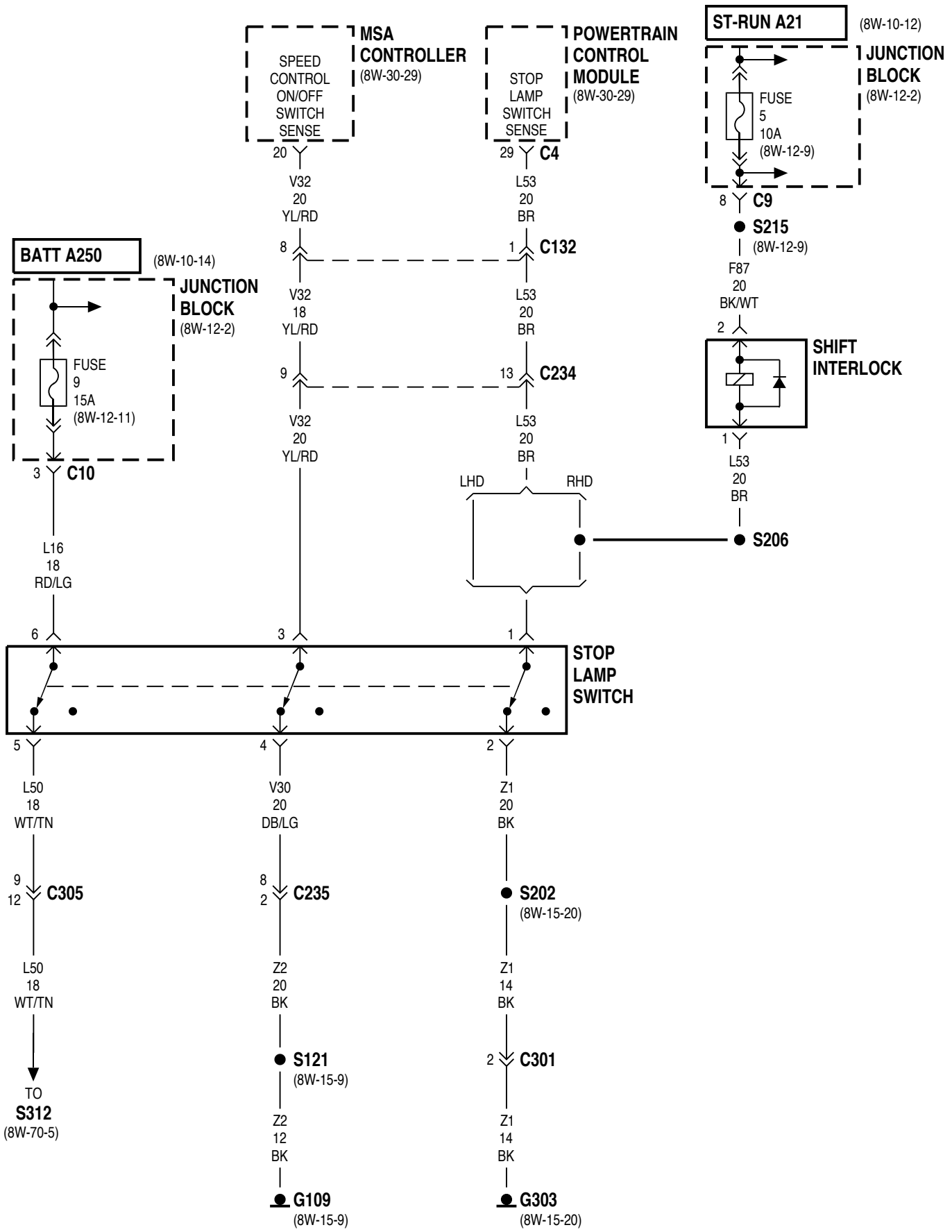


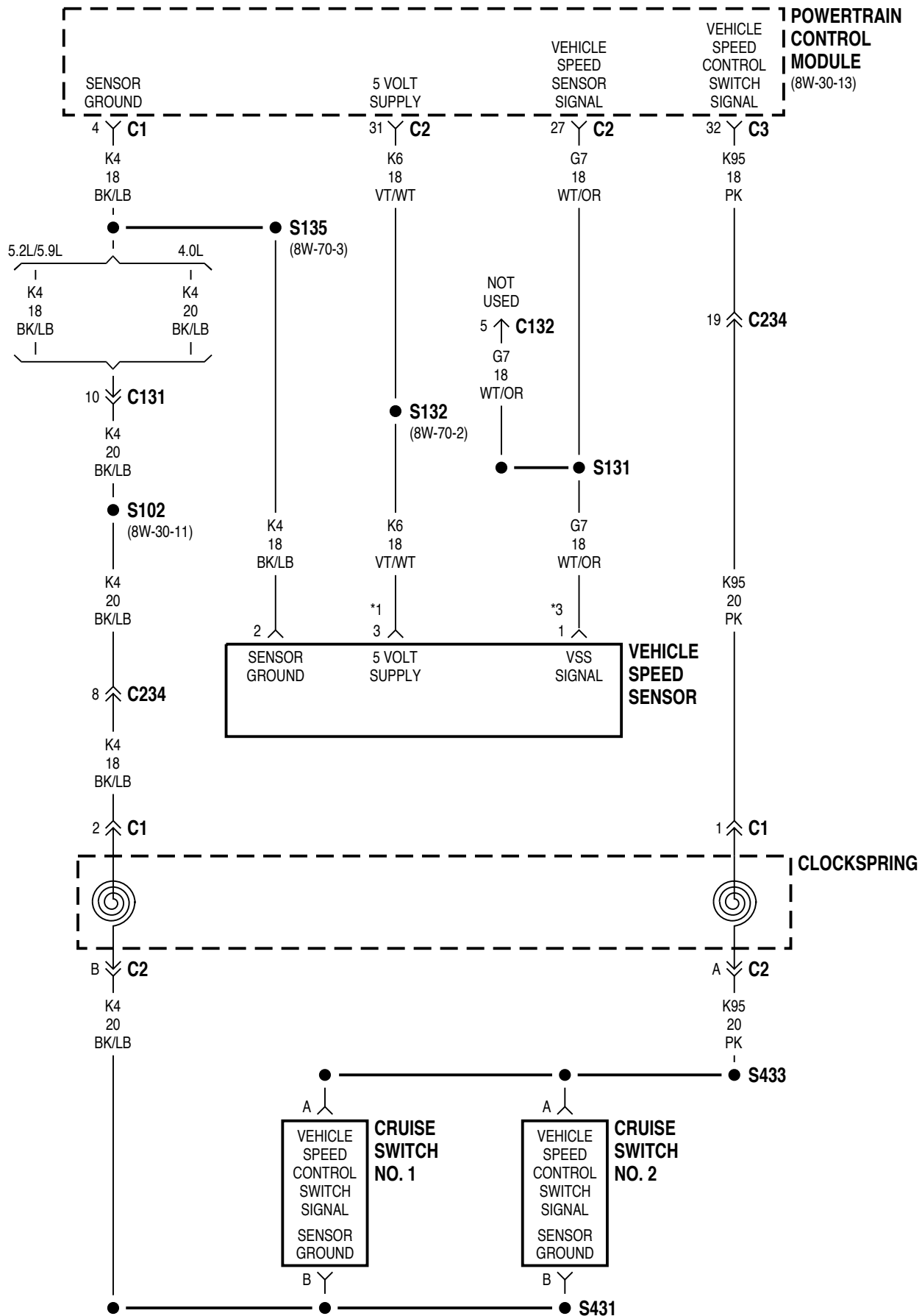


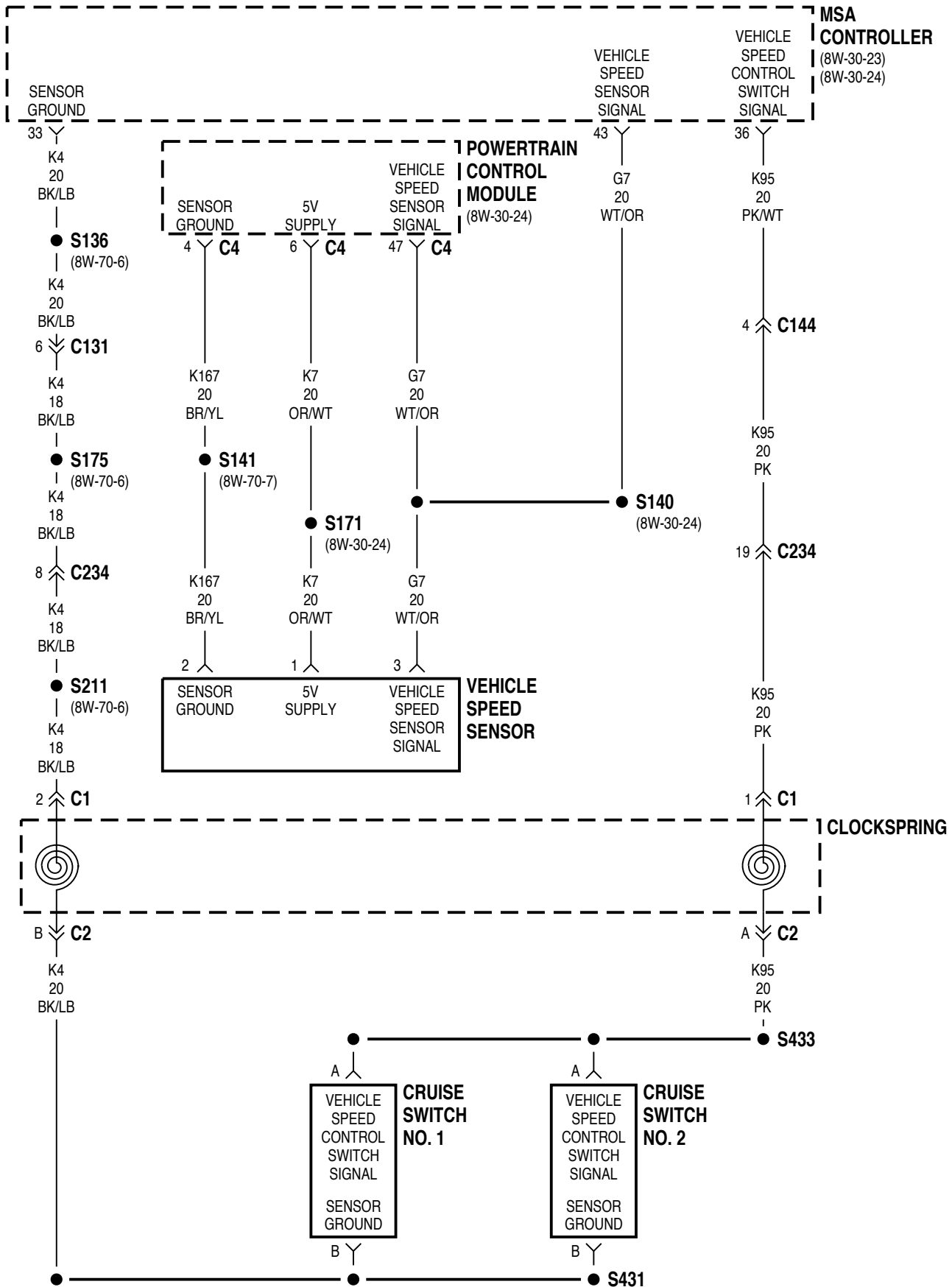
8W-33 VEHICLE SPEED CONTROL

Component	Page	Component	Page
Clockspring8W-33-4, 5	Junction Block8W-33-2, 3
Cruise Switch No. 18W-33-4, 5	MSA Controller8W-33-3, 5
Cruise Switch No. 28W-33-4, 5	Powertrain Control Module8W-33-2, 3, 4, 5
Fuse 5 (JB)8W-33-3	Shift Interlock8W-33-3
Fuse 9 (JB)8W-33-2, 3	Stop Lamp Switch8W-33-2, 3
G1078W-33-2	Vehicle Speed Control Servo8W-33-2
G1098W-33-3	Vehicle Speed Sensor8W-33-4, 5
G3038W-33-2, 3		



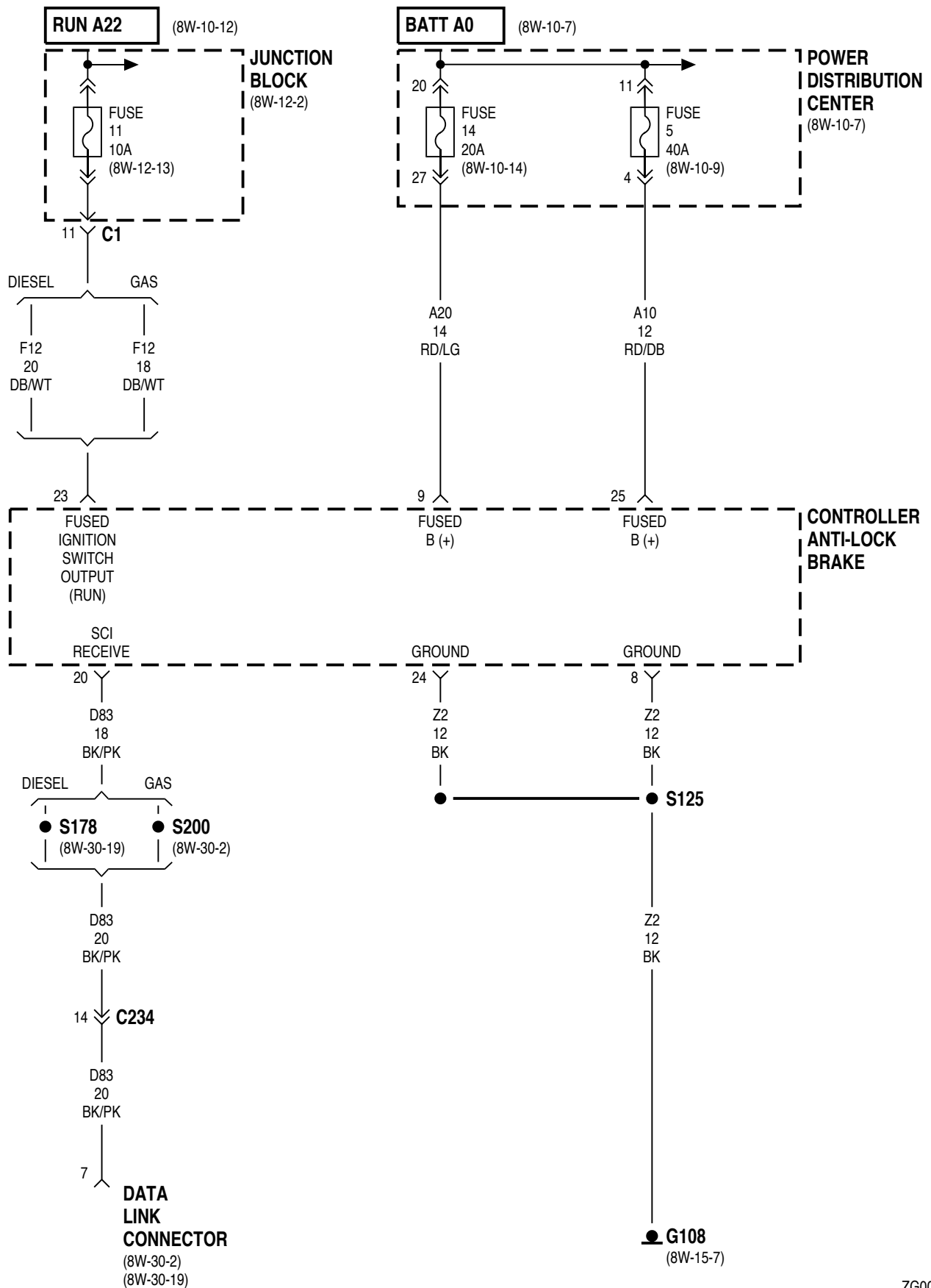


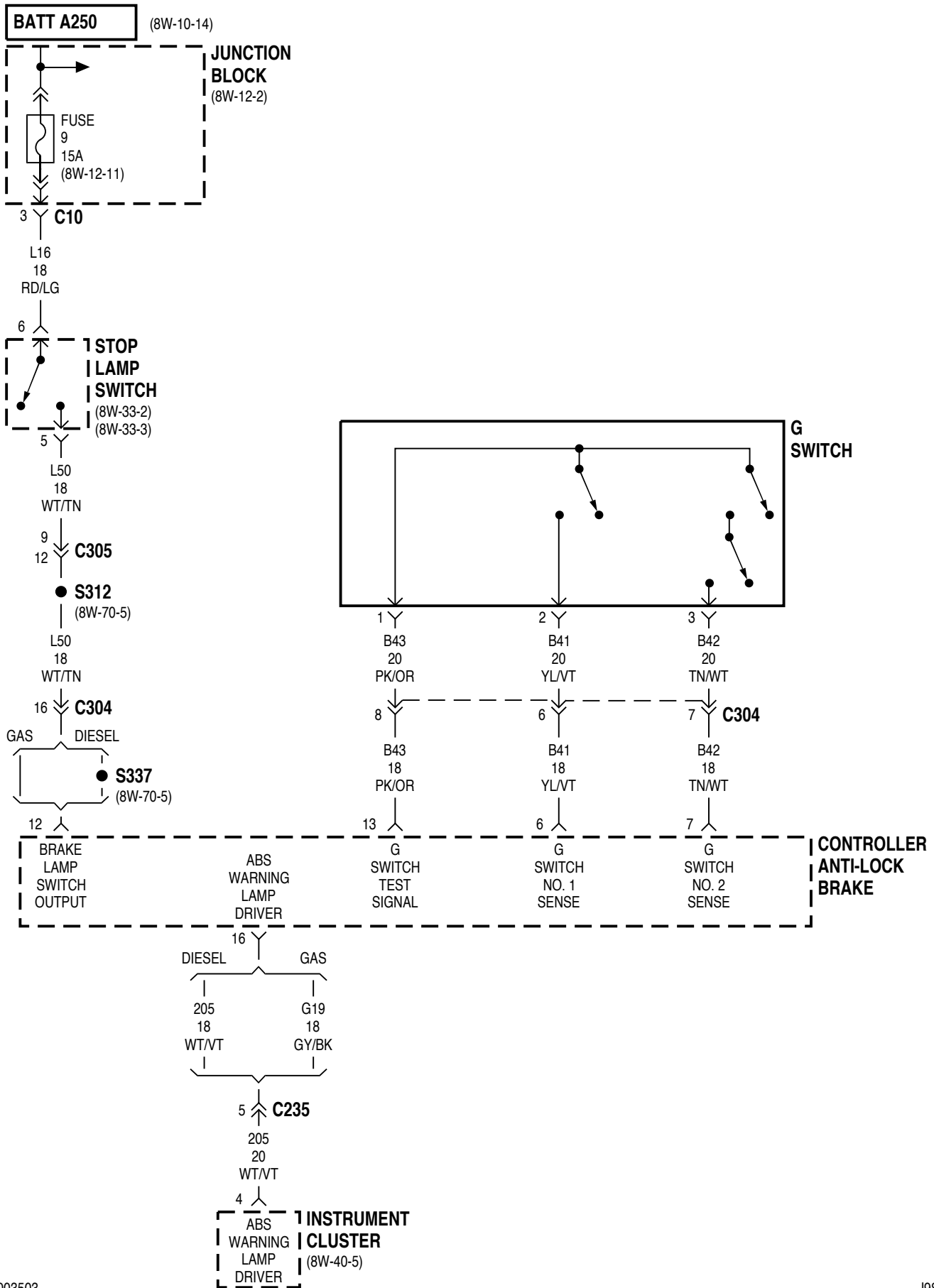


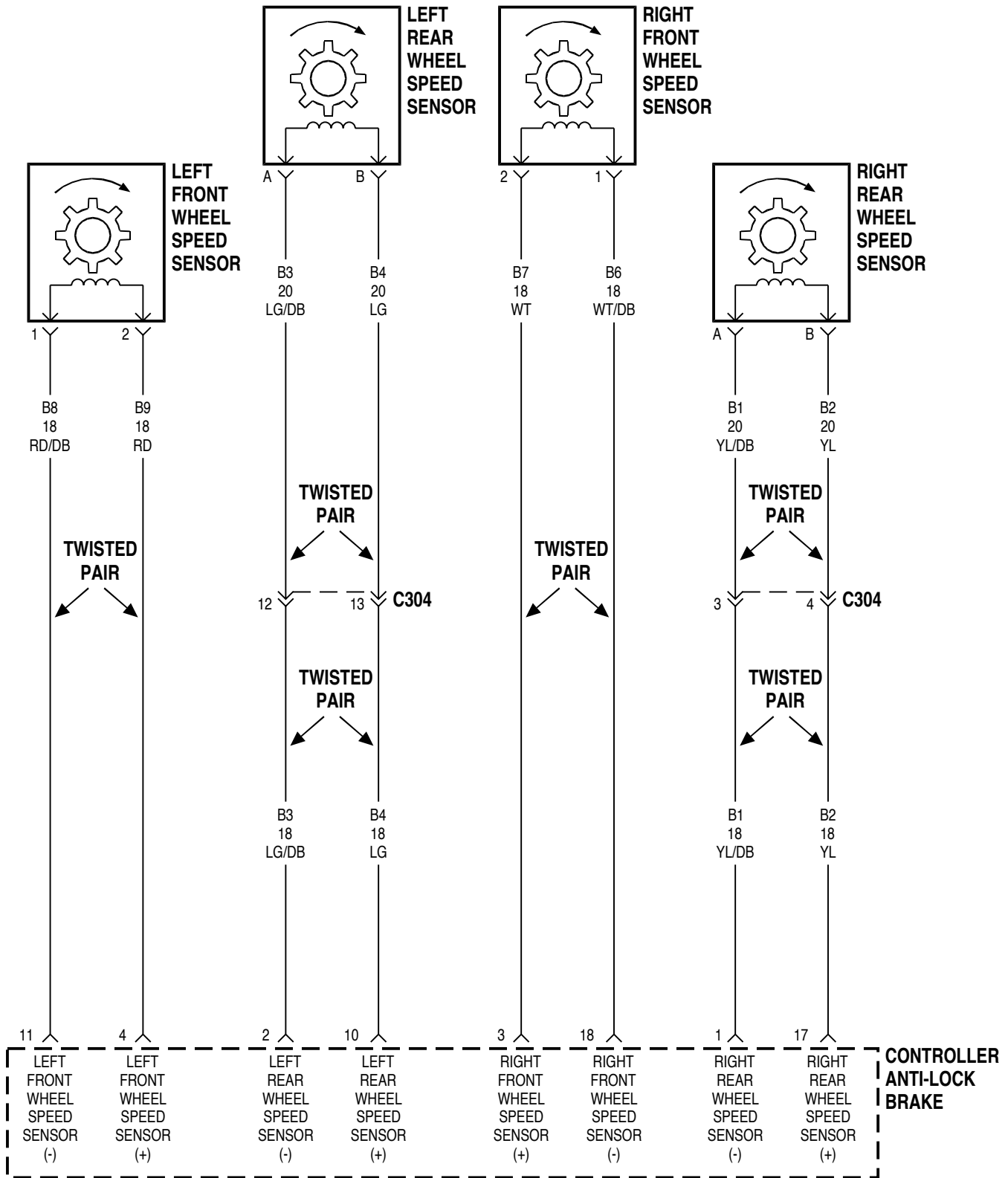


8W-35 ANTI-LOCK BRAKES

Component	Page	Component	Page
Controller Anti-Lock Brake	8W-35-2, 3, 4	Instrument Cluster	8W-35-3
Data Link Connector	8W-35-2	Junction Block	8W-35-2, 3
Fuse 5 (PDC)	8W-35-2	Left Front Wheel Speed Sensor	8W-35-4
Fuse 9 (JB)	8W-35-3	Left Rear Wheel Speed Sensor	8W-35-4
Fuse 11 (JB)	8W-35-2	Power Distribution Center	8W-35-2
Fuse 14 (PDC)	8W-35-2	Right Front Wheel Speed Sensor	8W-35-4
G Switch	8W-35-3	Right Rear Wheel Speed Sensor	8W-35-4
G108	8W-35-2	Stop Lamp Switch	8W-35-3

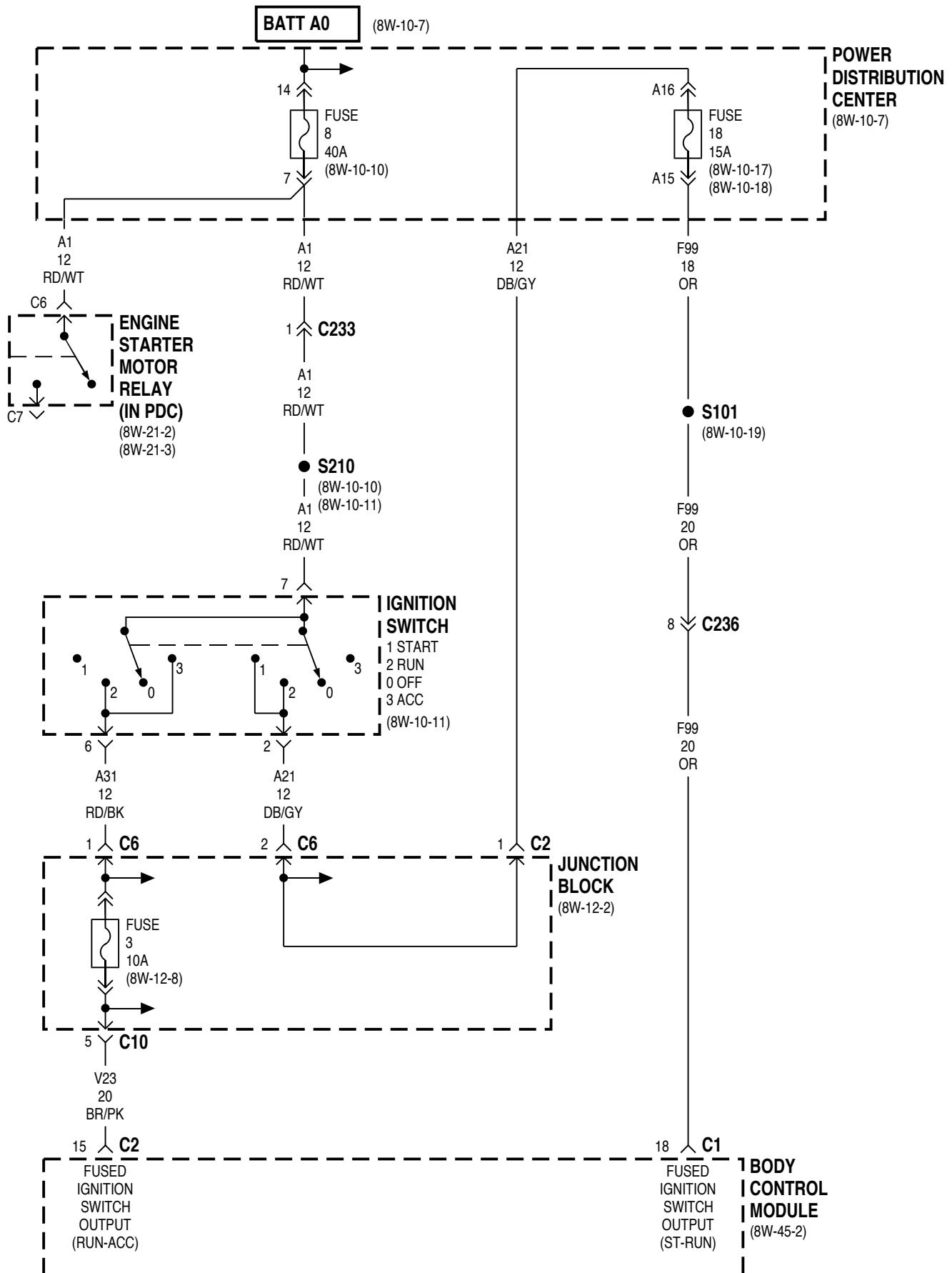


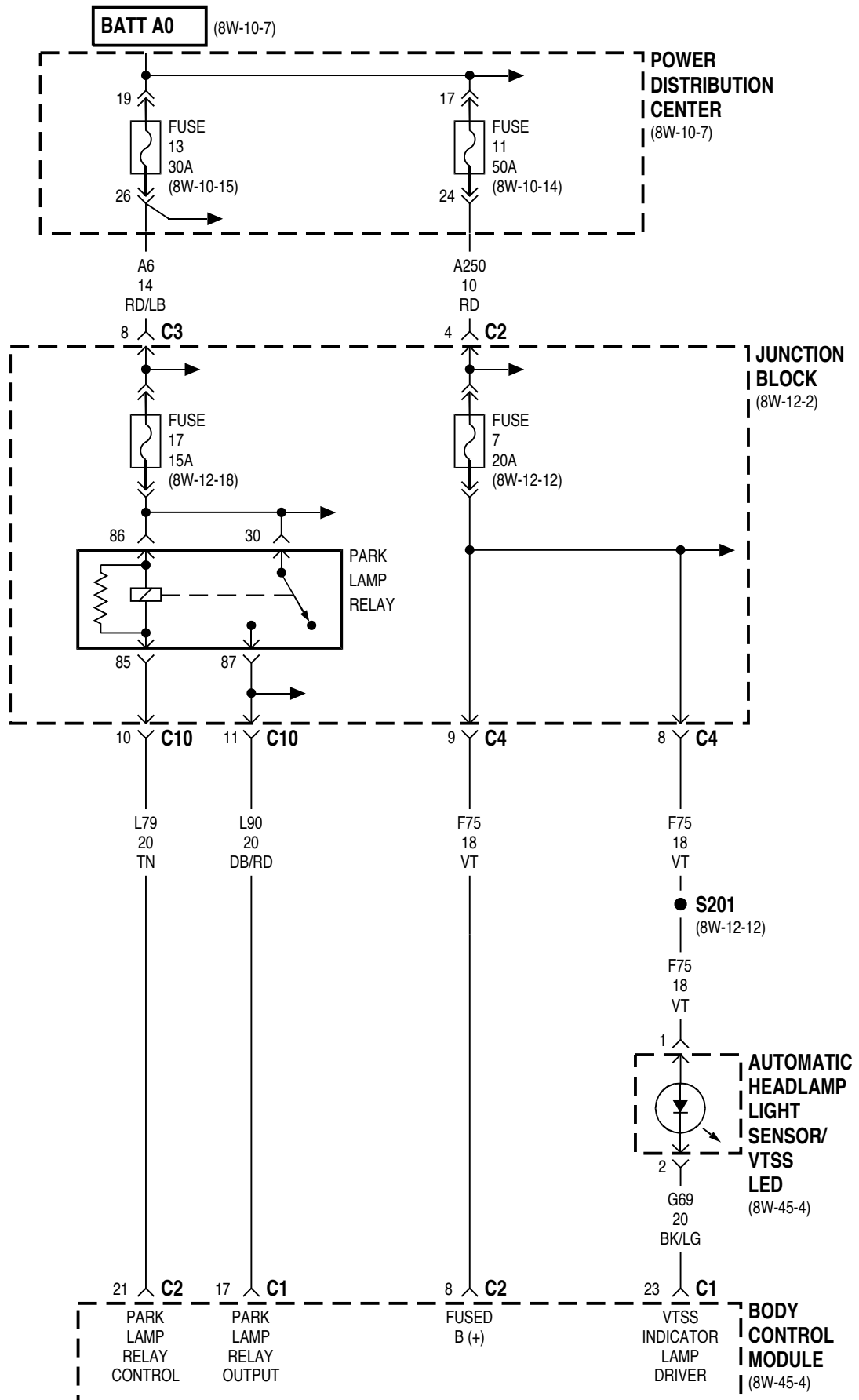


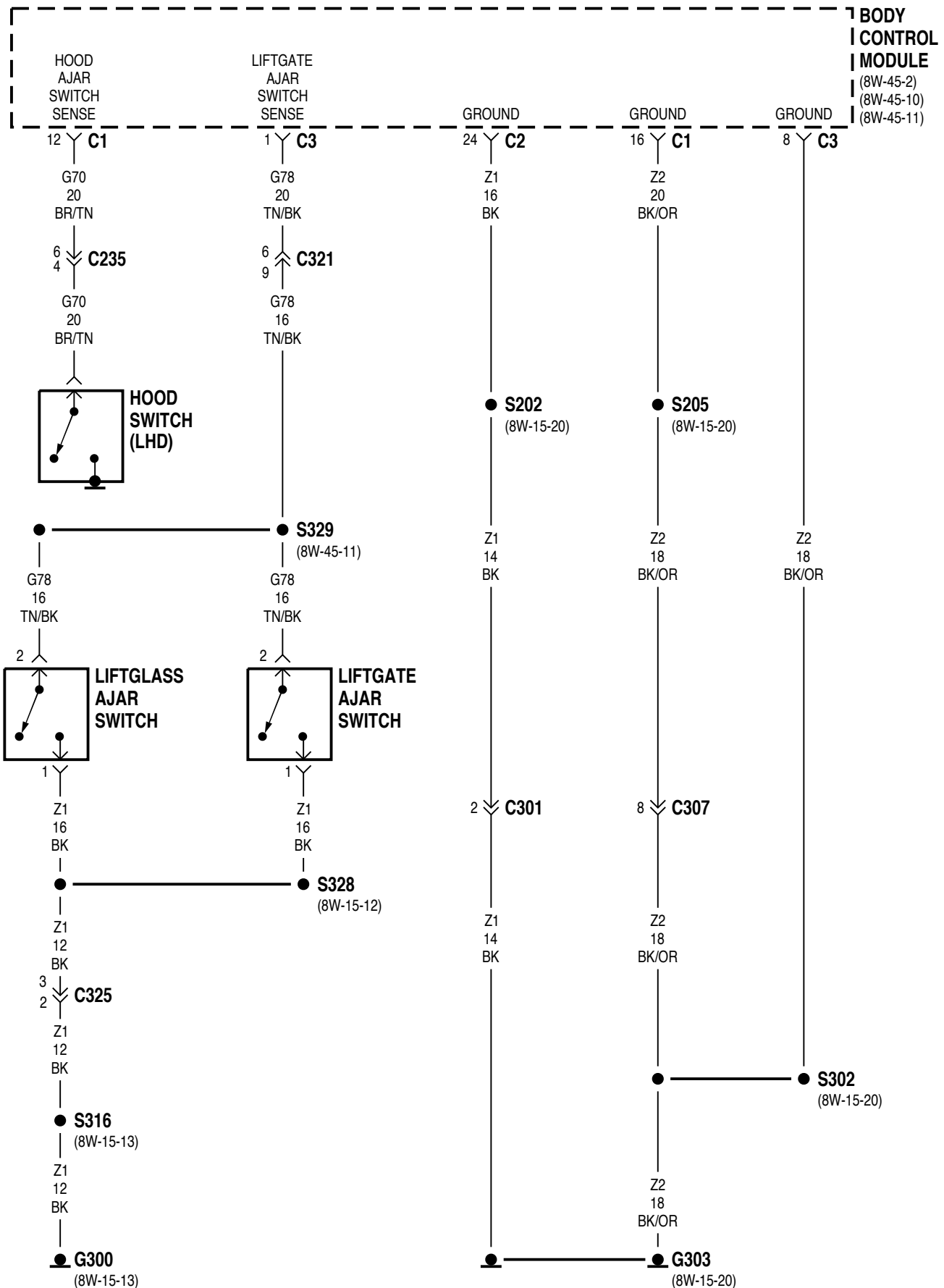


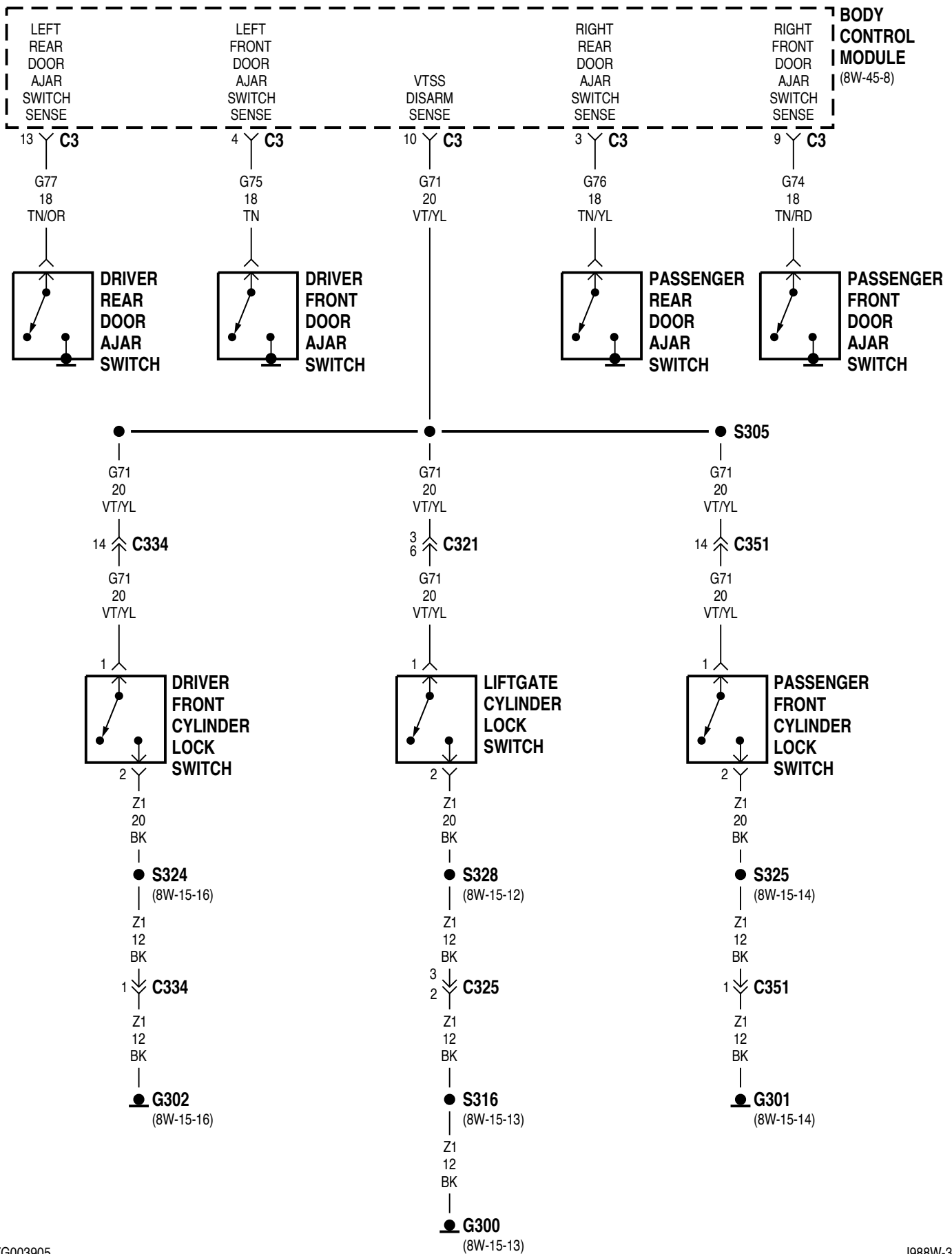
8W-39 VEHICLE THEFT SECURITY SYSTEM

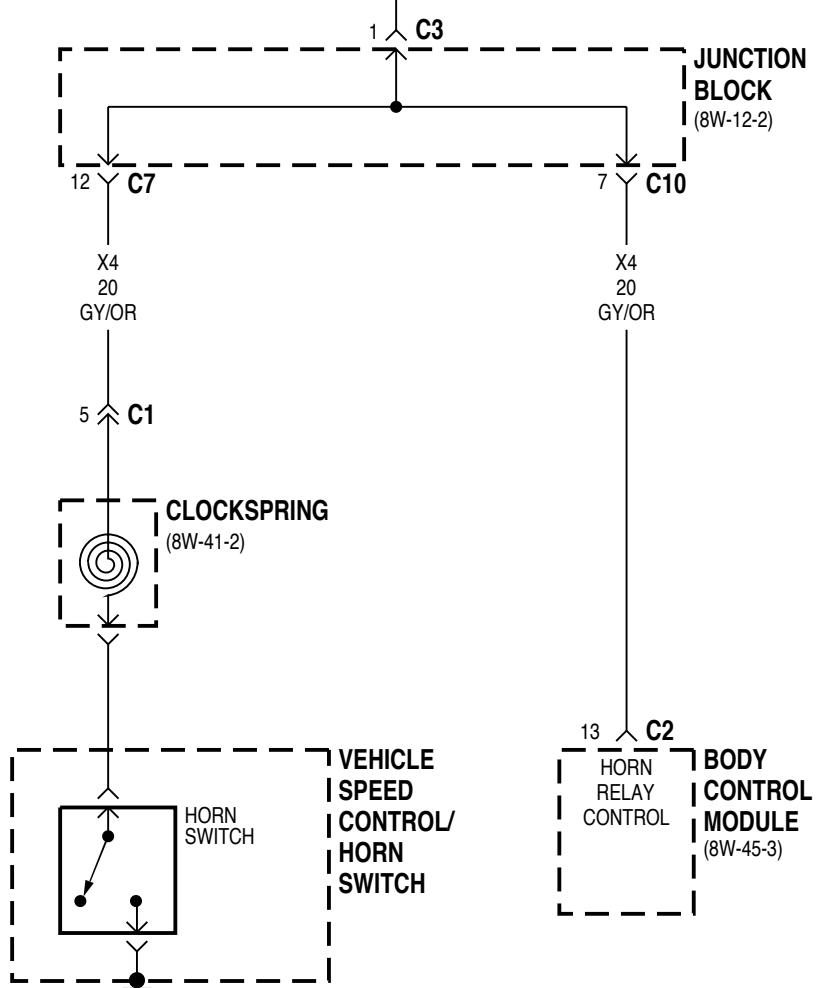
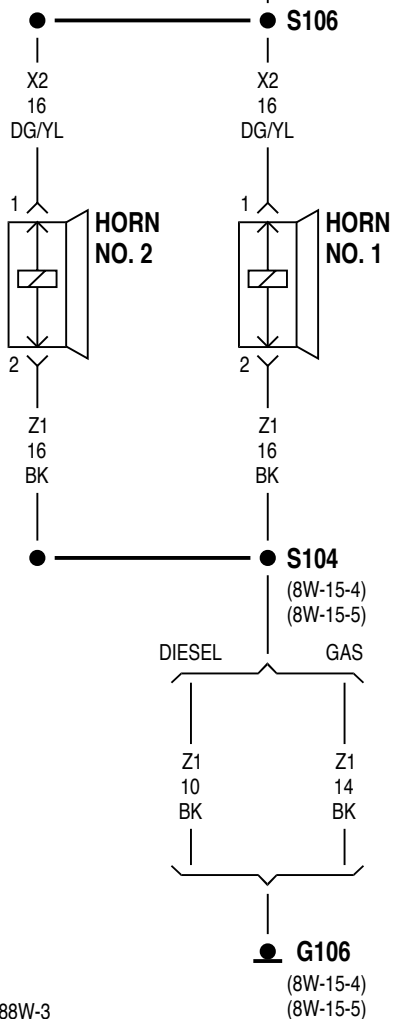
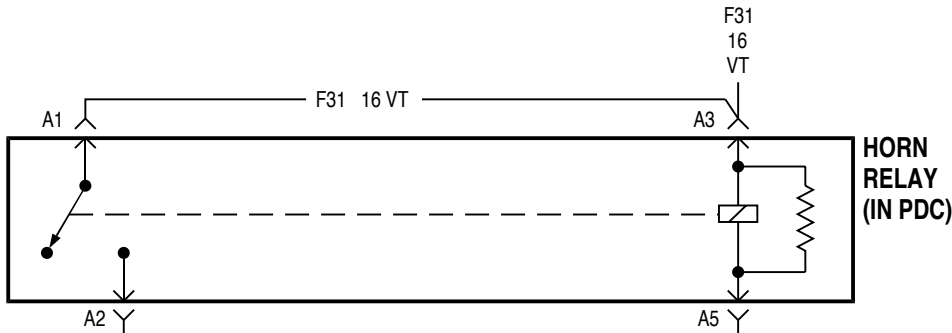
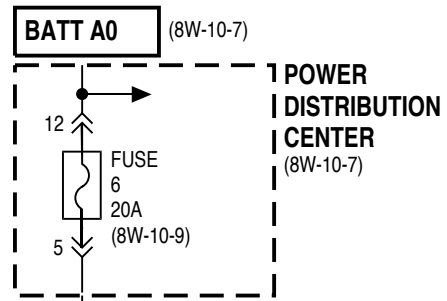
Component	Page	Component	Page
Automatic Headlamp Light Sensor/ Vtss Led8W-39-3	G3028W-39-5
Body Control Module.8W-39-2, 3, 4, 5, 6	G3038W-39-4
Clockspring No. 18W-39-6	Hood Switch8W-39-4
Driver Front Cylinder Lock Switch.8W-39-5	Horn No. 18W-39-6
Driver Front Door Ajar Switch8W-39-5	Horn No. 28W-39-6
Driver Rear Door Ajar Switch.8W-39-5	Horn Relay8W-39-6
Engine Starter Motor Relay8W-39-2	Horn Switch8W-39-6
Fuse 11 (PDC).8W-39-3	Ignition Switch8W-39-2
Fuse 13 (PDC)8W-39-3	Junction Block8W-39-2, 3, 6
Fuse 17 (JB)8W-39-3	Liftgate Ajar Switch8W-39-4
Fuse 18 (PDC)8W-39-2	Liftgate Cylinder Lock Switch8W-39-5
Fuse 3 (JB)8W-39-2	Liftglass Ajar Switch.8W-39-4
Fuse 6 (PDC)8W-39-6	Park Lamp Relay8W-39-3
Fuse 7 (JB)8W-39-3	Passenger Front Cylinder Lock Switch8W-39-5
Fuse 8 (PDC)8W-39-2	Passenger Front Door Ajar Switch8W-39-5
G1068W-39-6	Passenger Rear Door Ajar Switch8W-39-5
G3008W-39-4, 5	Power Distribution Center8W-39-2, 3, 6
G3018W-39-5	Vehicle Speed Control/Horn Switch.8W-39-6





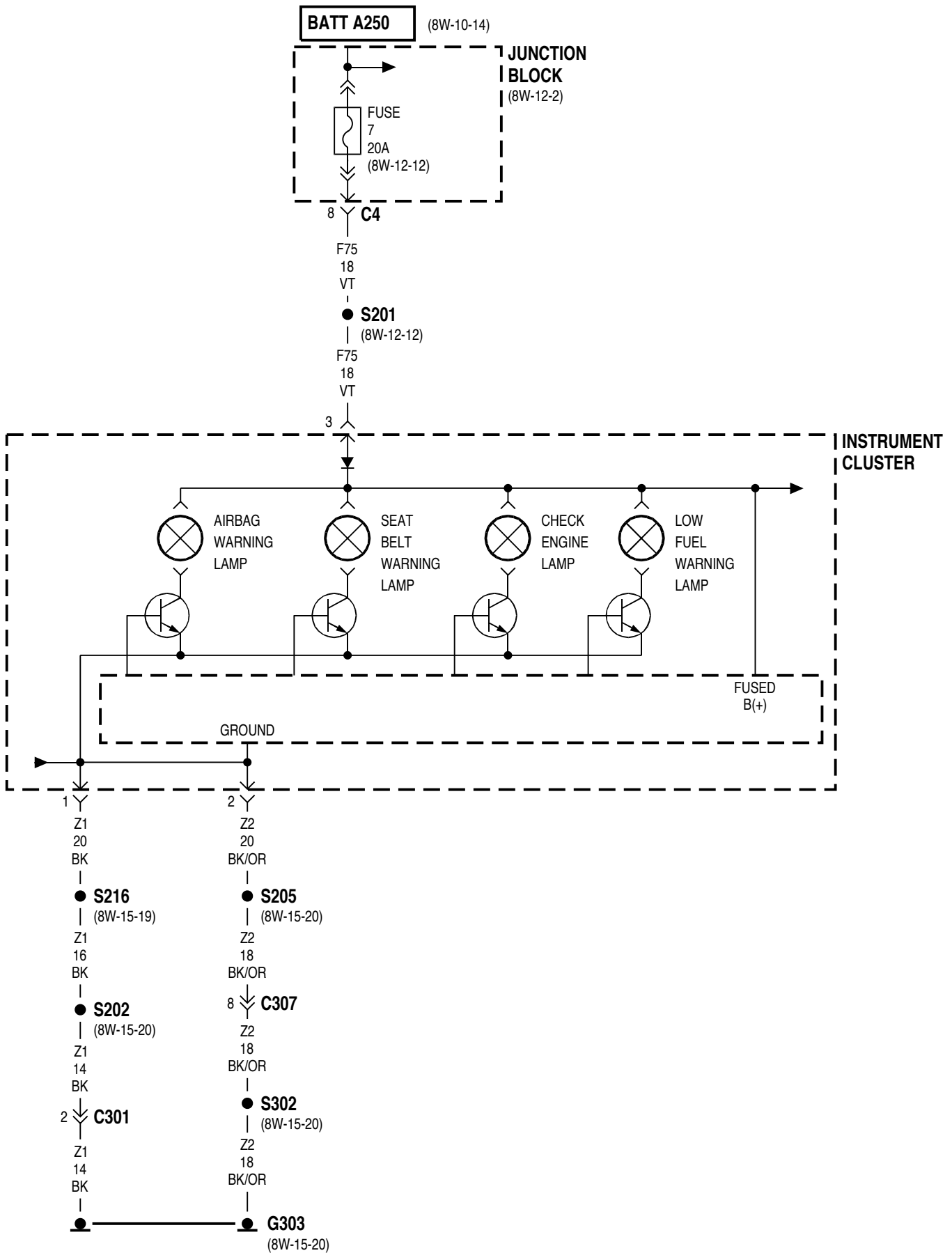


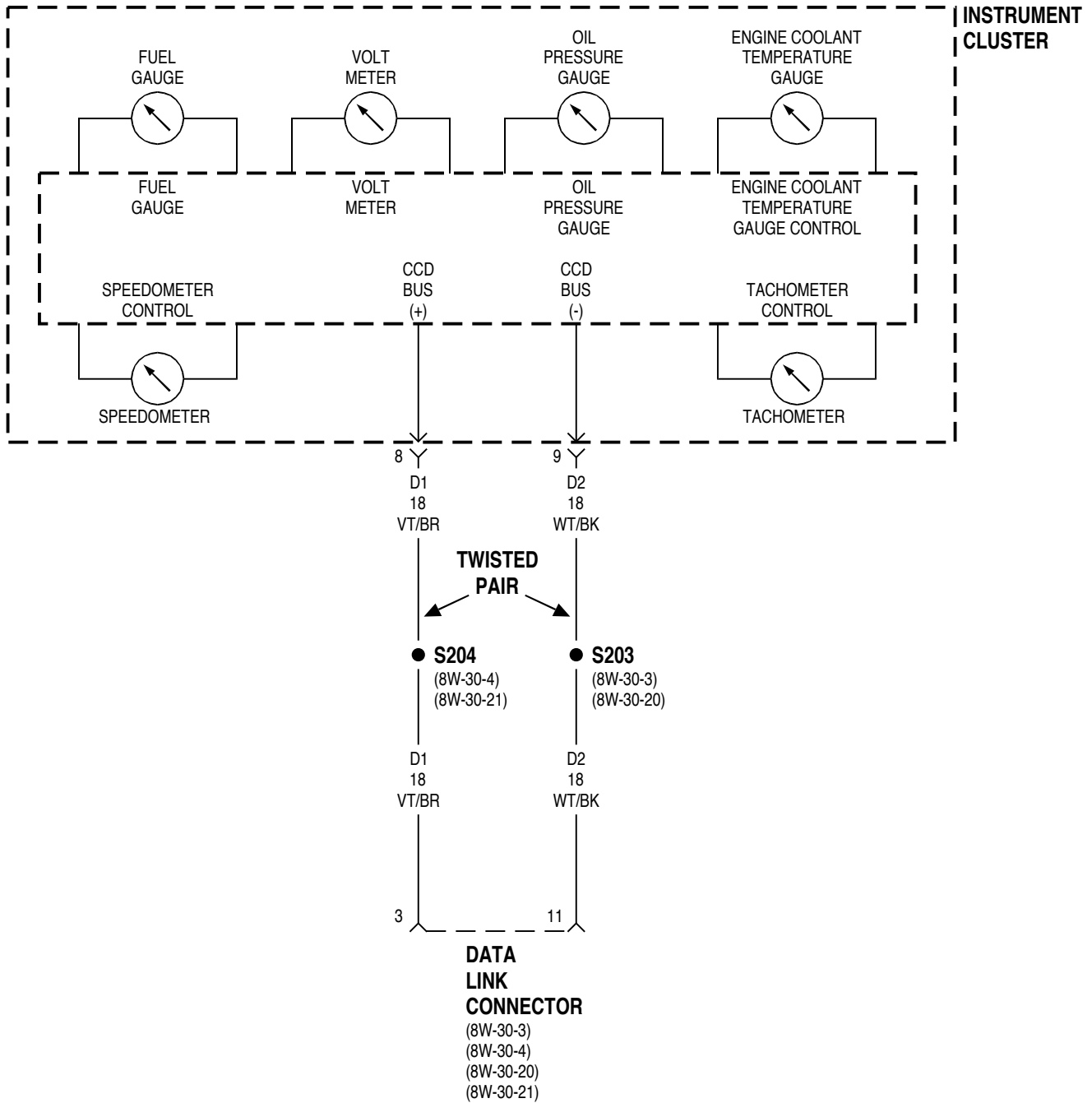


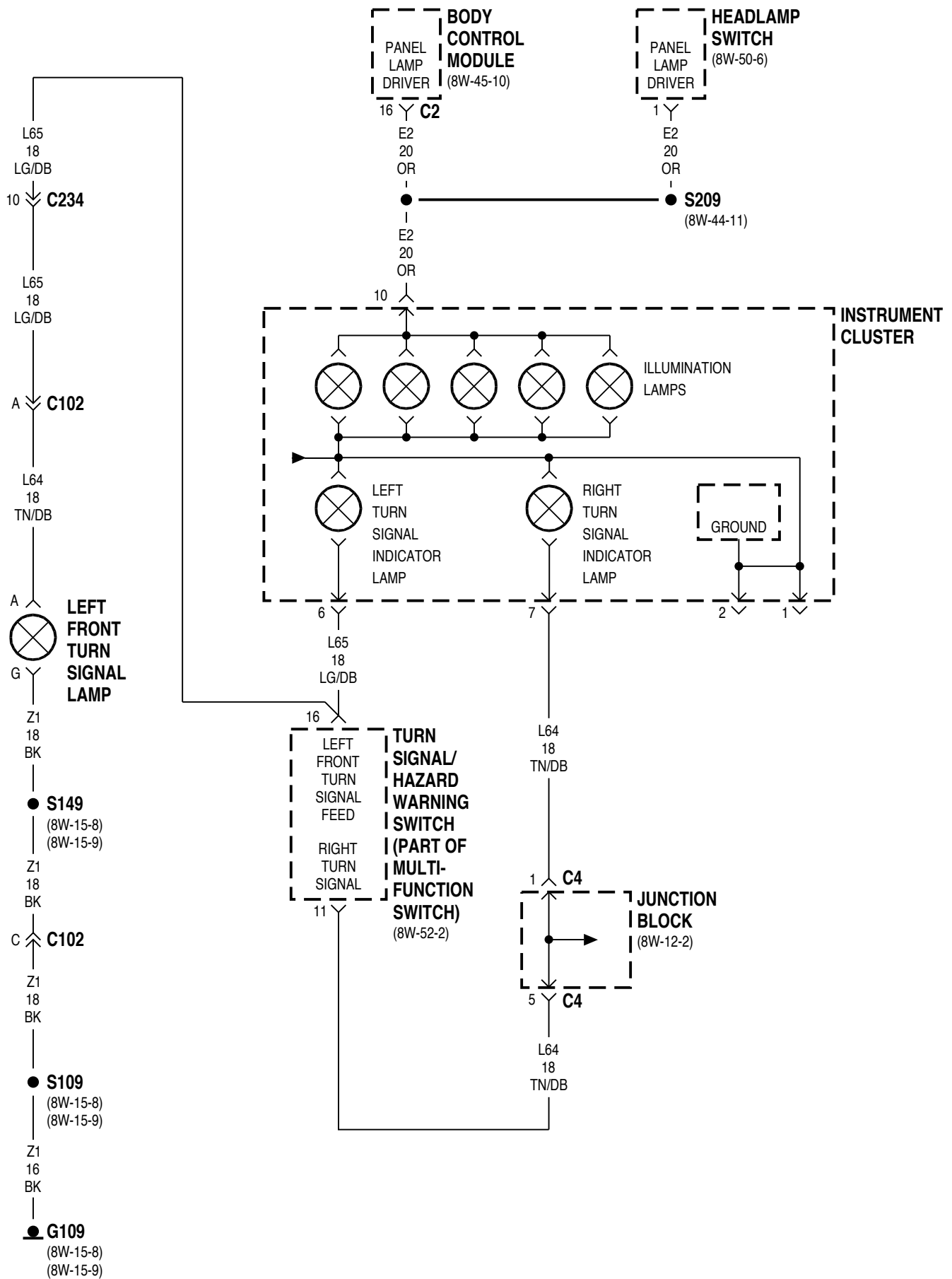


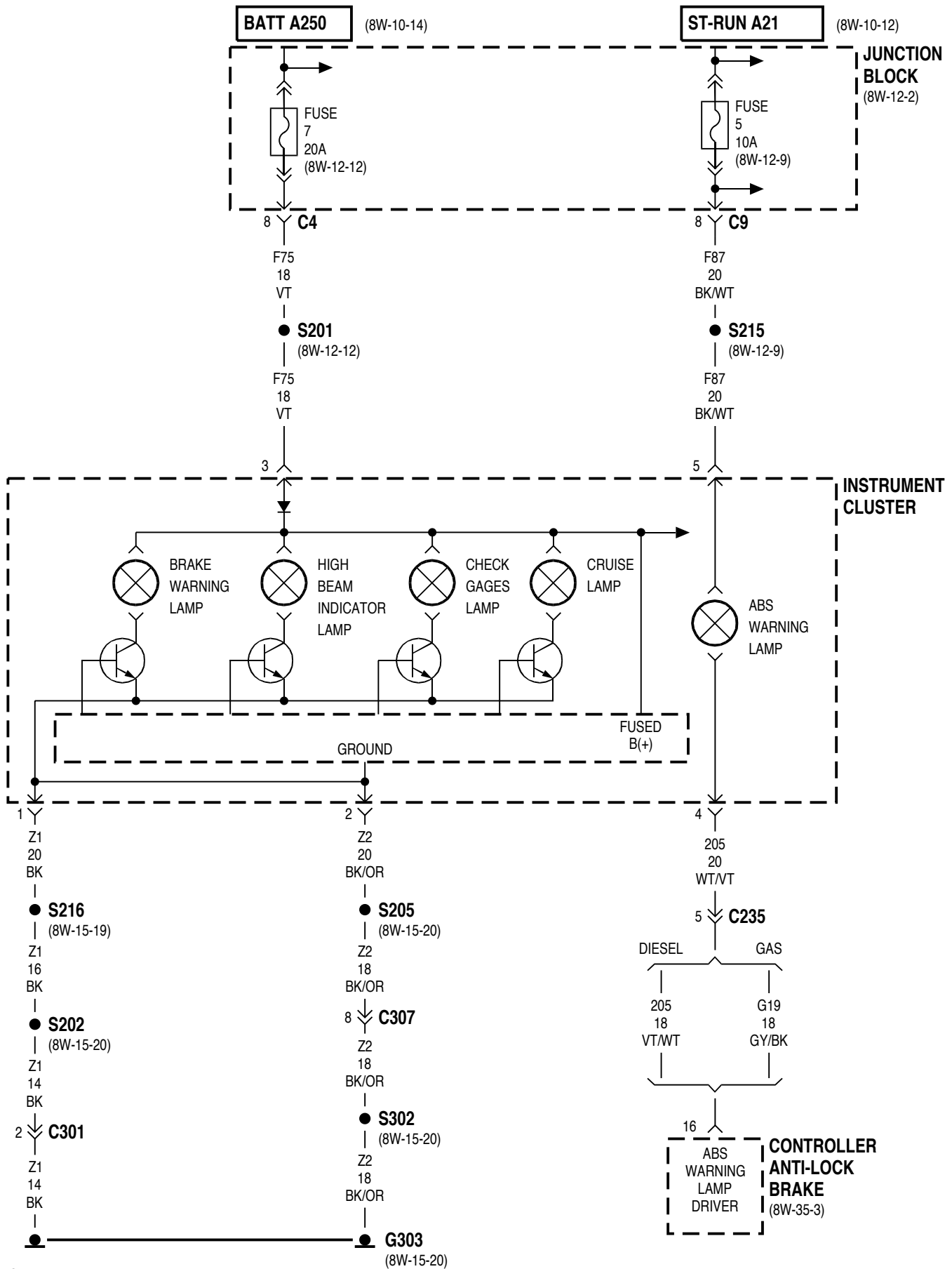
8W-40 INSTRUMENT CLUSTER

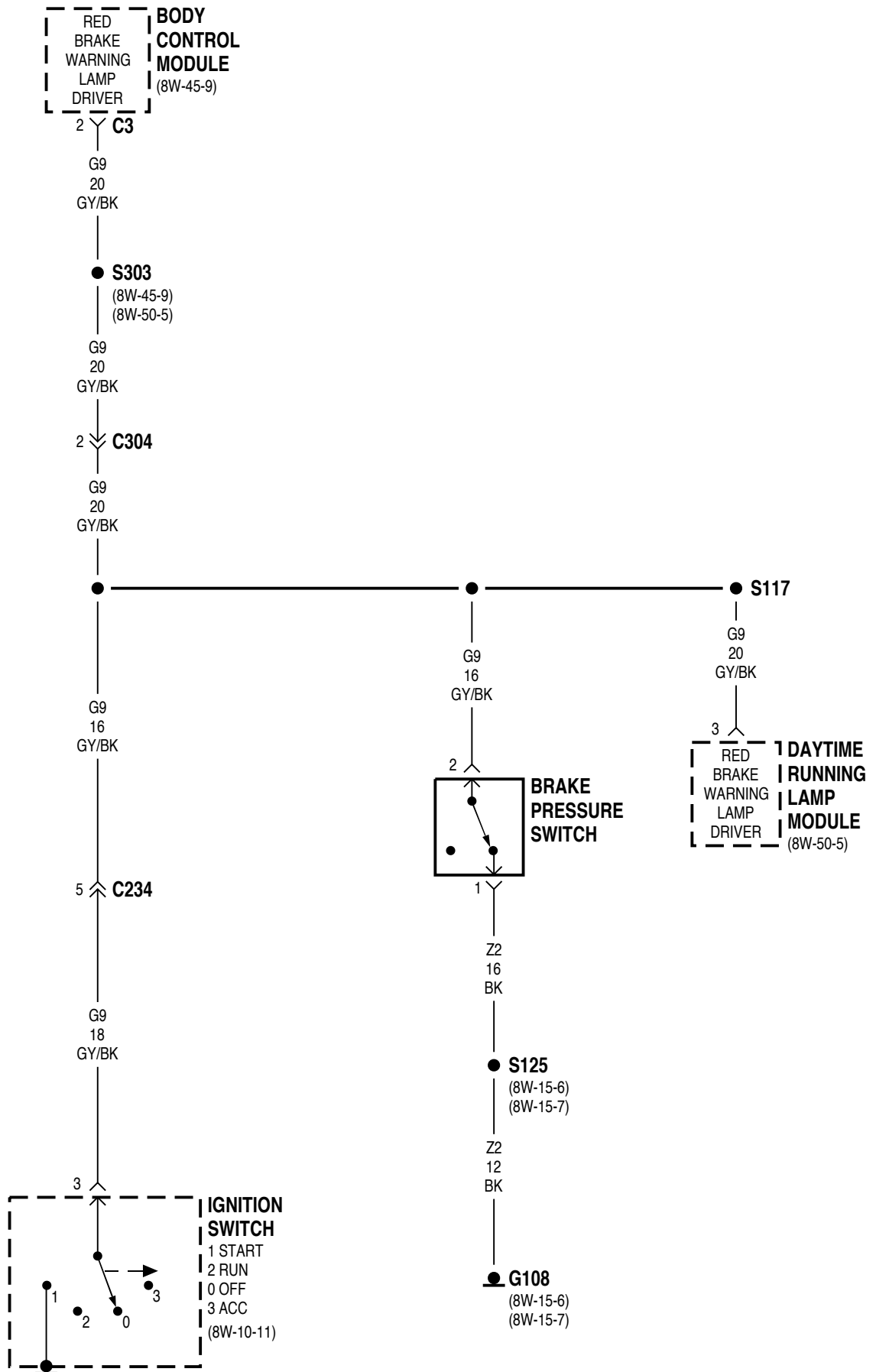
Component	Page	Component	Page
ABS Warning Lamp	8W-40-5	G303	8W-40-2, 5
Airbag Warning Lamp	8W-40-2	Headlamp Switch	8W-40-4
Body Control Module	8W-40-4, 6	High Beam Indicator Lamp	8W-40-5
Brake Pressure Switch	8W-40-6	Ignition Switch	8W-40-6
Brake Warning Lamp	8W-40-5	Illumination Lamps	8W-40-4
Check Engine Lamp	8W-40-2	Instrument Cluster	8W-40-2, 3, 4, 5
Check Gages Lamp	8W-40-5	Junction Block	8W-40-2, 4, 5
Controller Anti-Lock Brake	8W-40-5	Left Front Turn Signal Lamp	8W-40-4
Cruise Lamp	8W-40-5	Left Turn Signal Indicator Lamp	8W-40-4
Data Link Connector	8W-40-3	Low Fuel Warning Lamp	8W-40-2
Daytime Running Lamp Module	8W-40-6	Oil Pressure Gauge	8W-40-3
Engine Coolant Temperature Gauge	8W-40-3	Right Turn Signal Indicator Lamp	8W-40-4
Fuel Gauge	8W-40-3	Seat Belt Warning Lamp	8W-40-2
Fuse 5 (JB)	8W-40-5	Speedometer	8W-40-3
Fuse 7 (JB)	8W-40-2, 5	Tachometer	8W-40-3
G108	8W-40-6	Turn Signal/Hazard Warning Switch	8W-40-4
G109	8W-40-4	Volt Meter	8W-40-3





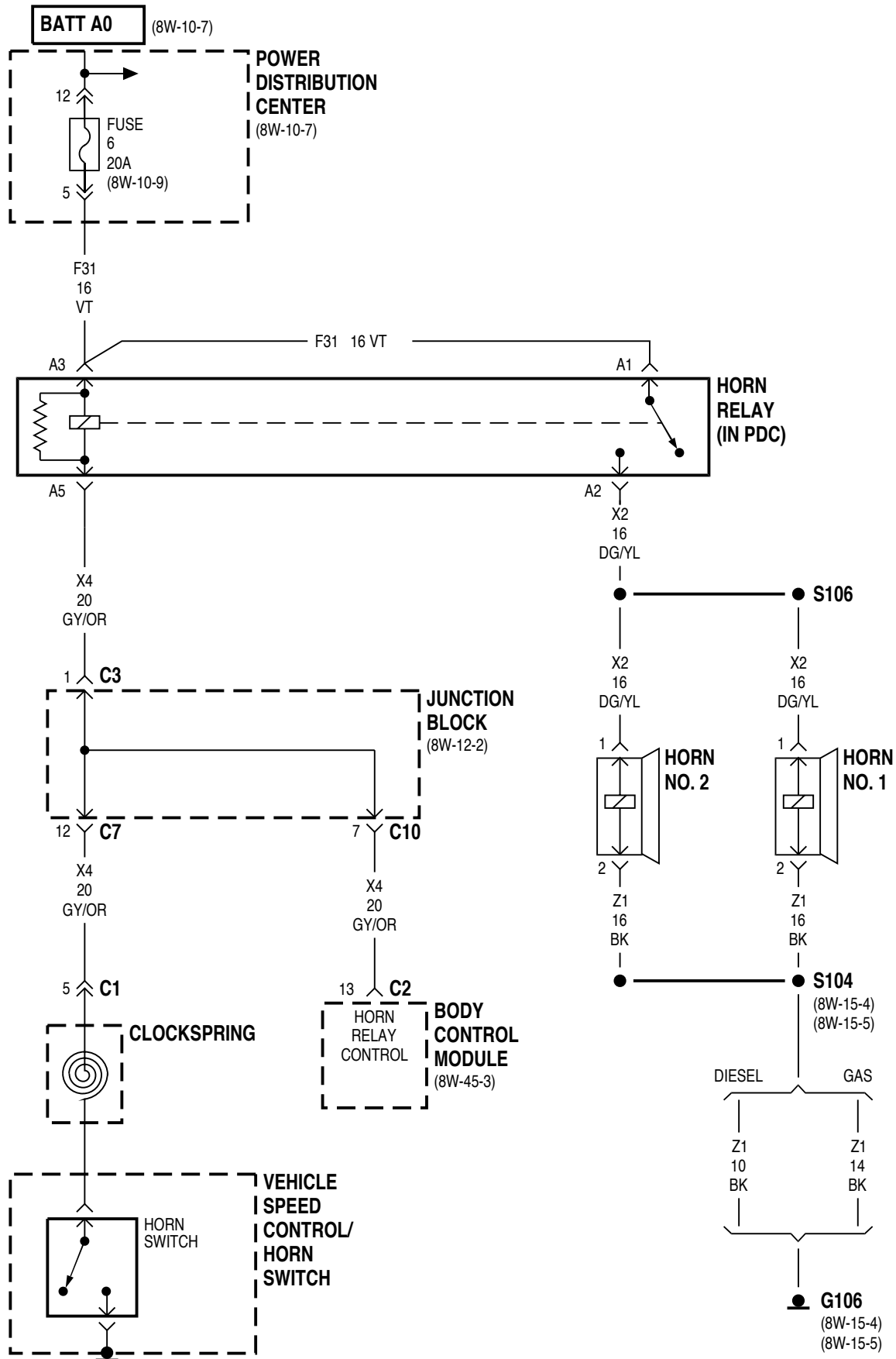




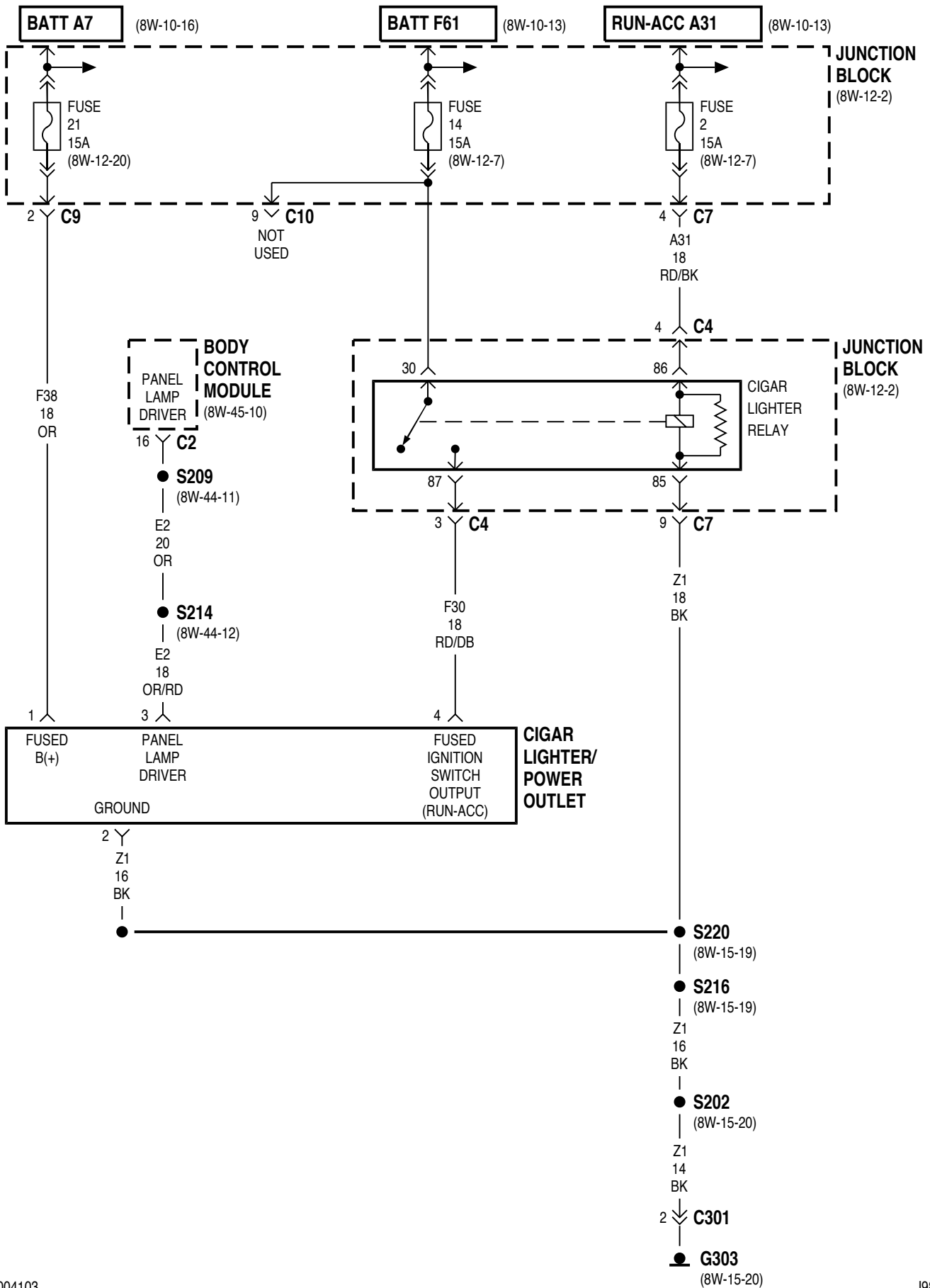


8W-41 HORN/CIGAR LIGHTER

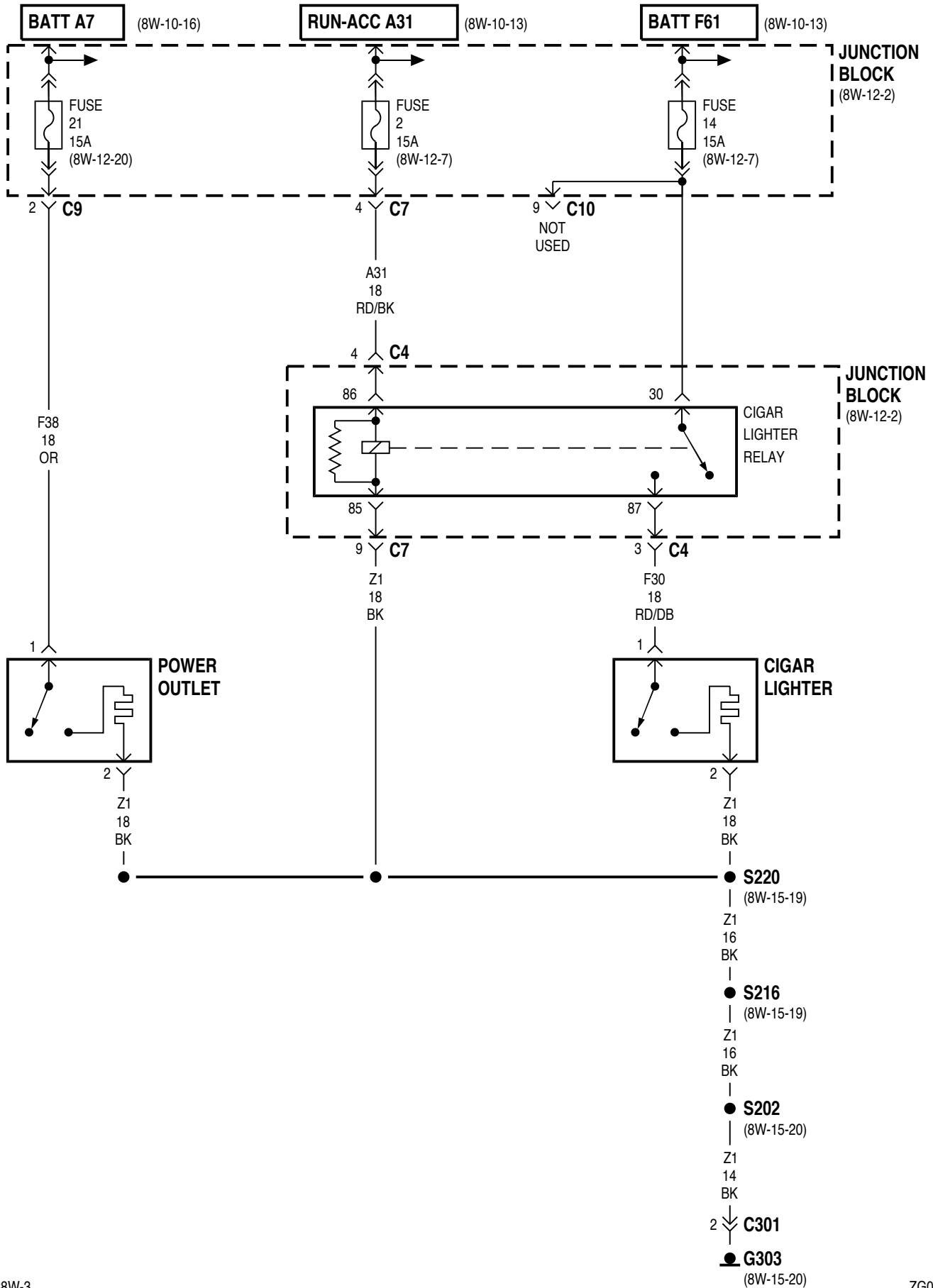
Component	Page	Component	Page
Body Control Module	8W-41-2, 3	G303	8W-41-3, 4
Cigar Lighter	8W-41-4	Horn No. 1	8W-41-2
Cigar Lighter Relay	8W-41-3, 4	Horn No. 2	8W-41-2
Cigar Lighter/Power Outlet	8W-41-3	Horn Relay	8W-41-2
Clockspring	8W-41-2	Horn Switch	8W-41-2
Fuse 2 (JB)	8W-41-3, 4	Junction Block	8W-41-2, 3, 4
Fuse 6 (PDC)	8W-41-2	Power Distribution Center	8W-41-2
Fuse 14 (JB)	8W-41-3, 4	Power Outlet	8W-41-4
Fuse 21 (JB)	8W-41-3, 4	Vehicle Speed Control/Horn Switch.	8W-41-2
G106	8W-41-2		



LHD

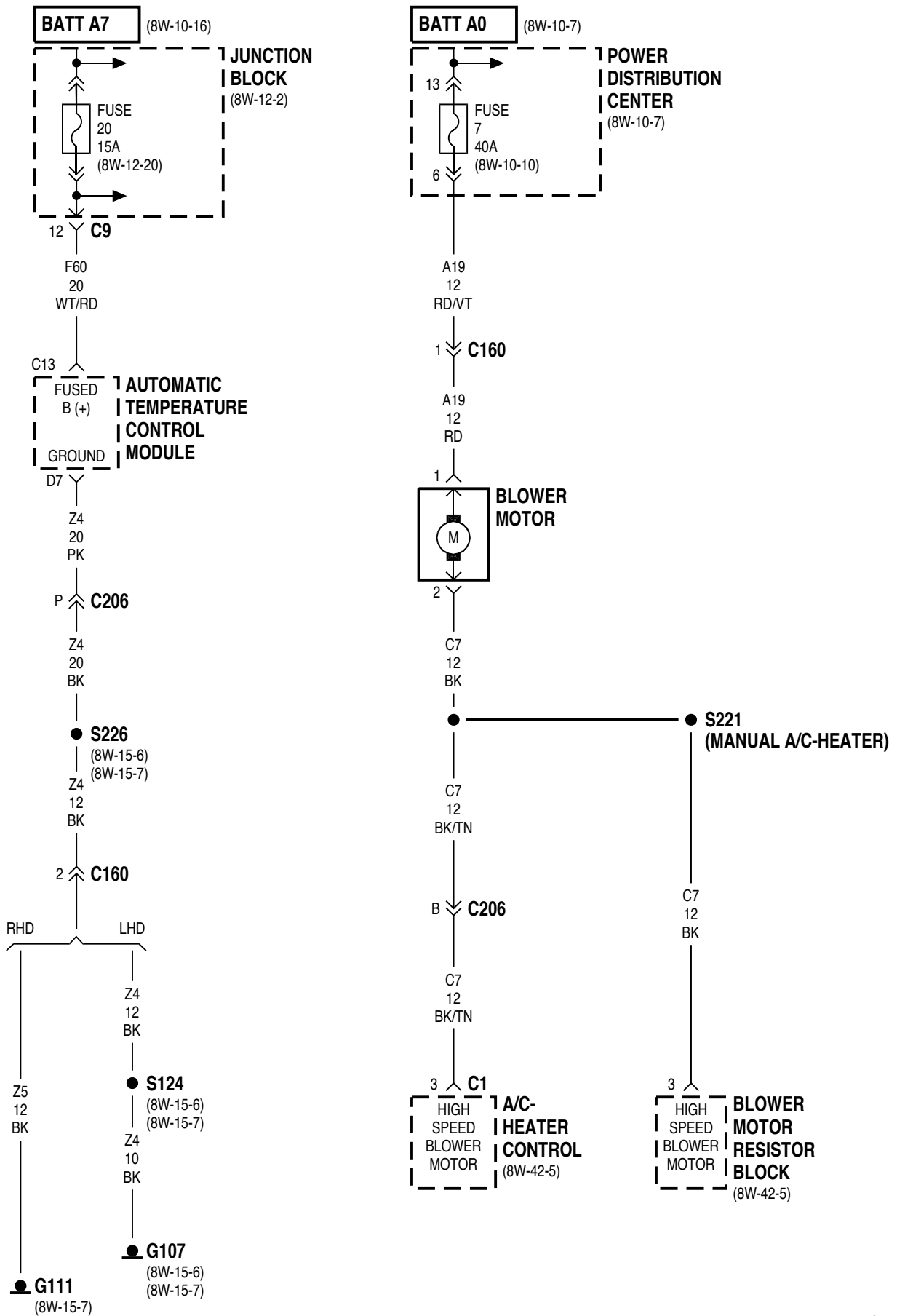


RHD

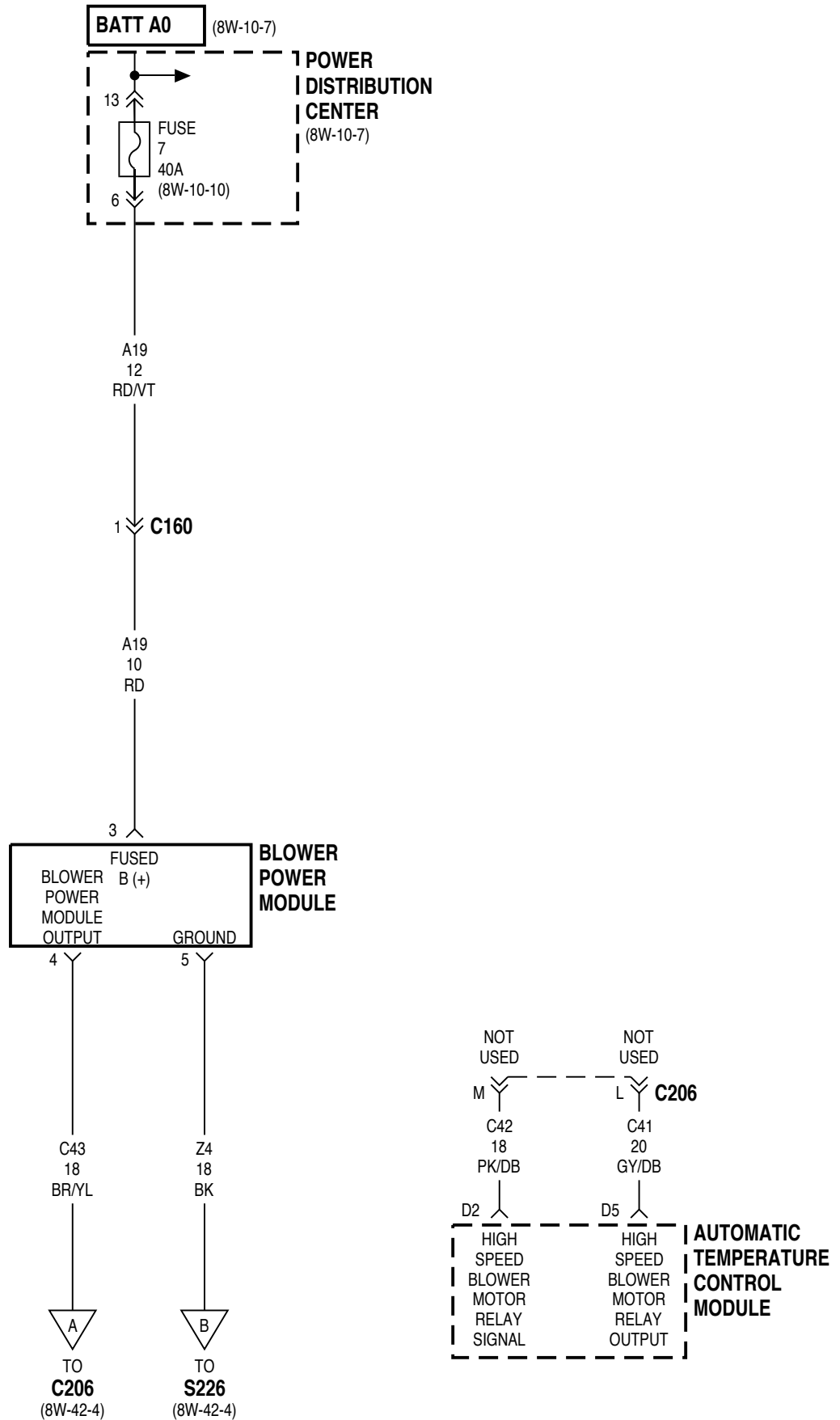


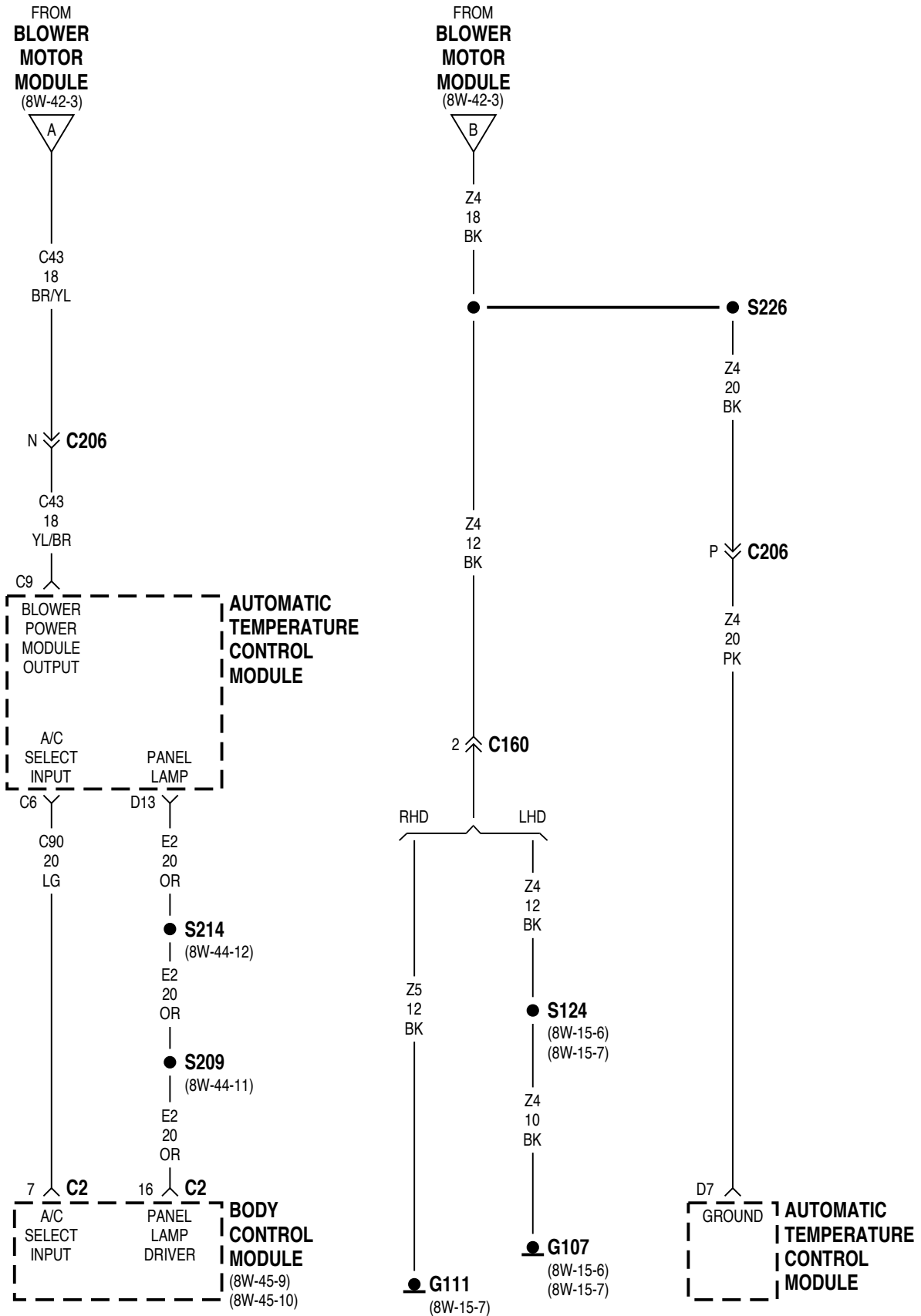
8W-42 AIR CONDITIONING/HEATER

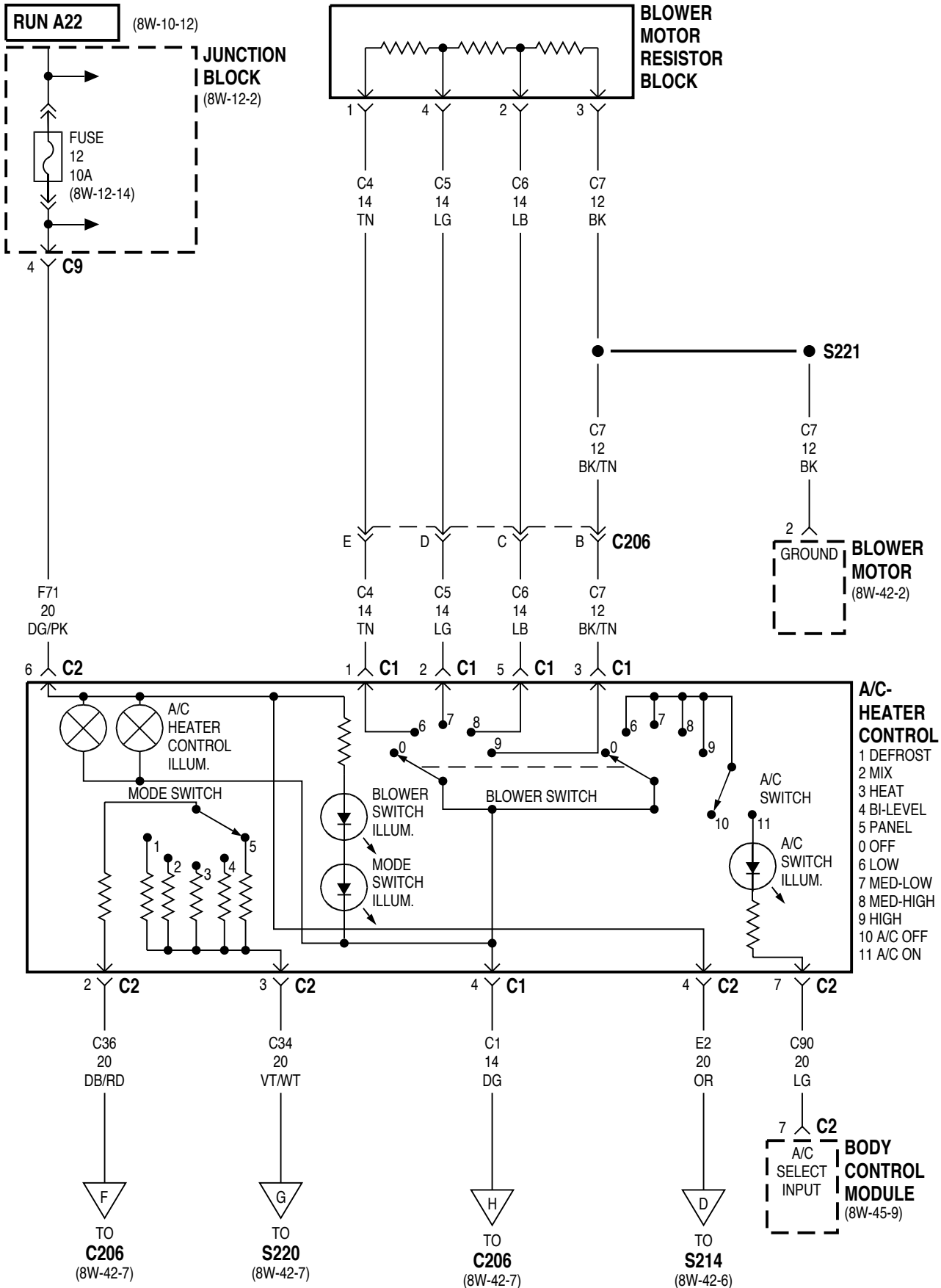
Component	Page	Component	Page
A/C Compressor Clutch	8W-42-10, 11	Fuse 18 (PDC).	8W-42-10
A/C Compressor Clutch Relay	8W-42-10, 11	Fuse 20 (JB)	8W-42-2
A/C Heater Control	8W-42-2, 5	Fuse 20 (PDC).	8W-42-11
A/C High Pressure Switch.	8W-42-12, 13	Fuse 21 (PDC).	8W-42-10, 11
A/C Low Pressure Switch	8W-42-12, 13	G104	8W-42-11
Ambient Temperature Sensor	8W-42-6	G105	8W-42-10
Automatic Shutdown Relay	8W-42-11	G106	8W-42-10, 11, 12
Automatic Temperature Control		G107	8W-42-2, 4, 7
Module	8W-42-2, 3, 4, 6, 8, 9	G111	8W-42-2, 4, 7
Blend Door Actuator	8W-42-6, 7, 8	G303	8W-42-7
Blower Motor	8W-42-2, 5	In-Car Temperature Sensor	8W-42-6
Blower Motor Resistor Block.	8W-42-2, 5	Junction Block	8W-42-2, 5, 7, 9
Blower Power Module	8W-42-3	Mode Door Actuator	8W-42-6, 8
Body Control Module	8W-42-4, 5, 6	MSA Controller	8W-42-13
Data Link Connector	8W-42-9	Power Distribution Center.	8W-42-2, 3, 10, 11
Fuse 3 (PDC).	8W-42-11	Powertrain Control Module.	8W-42-12, 13
Fuse 7 (PDC)	8W-42-2, 3	Recirculation Door Actuator	8W-42-9
Fuse 12 (JB)	8W-42-5, 7, 9	Solar Sensor	8W-42-6

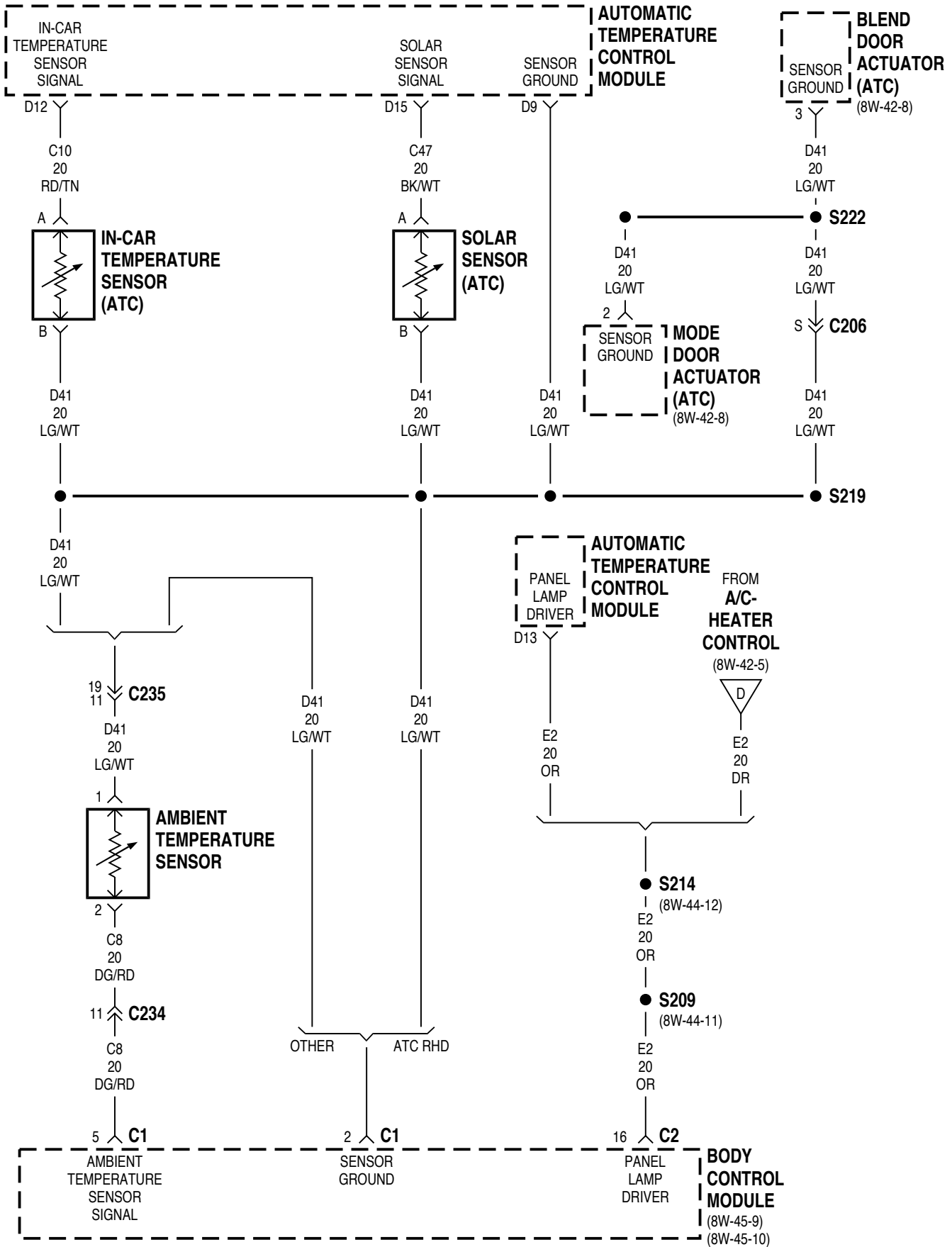


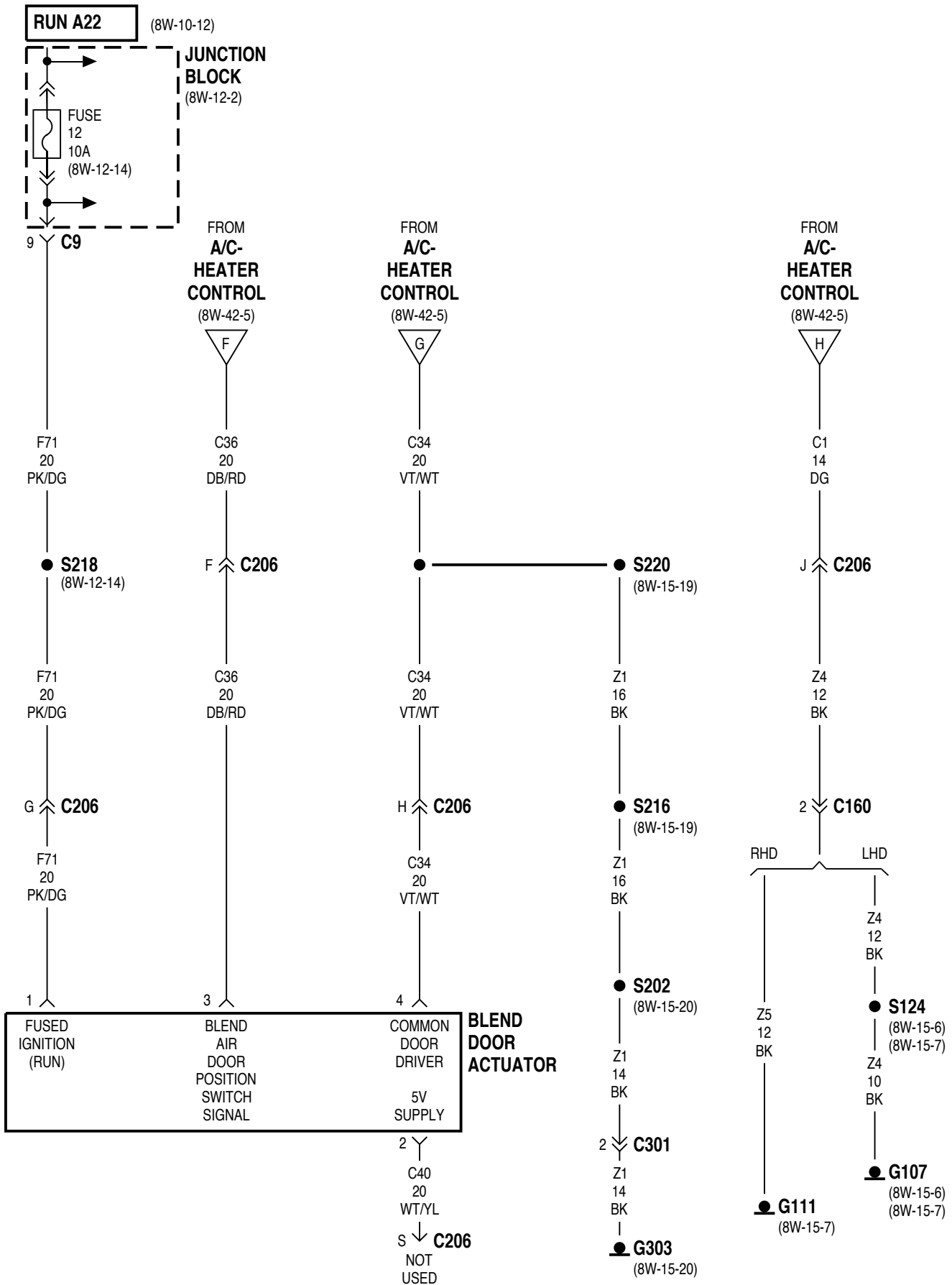
ATC

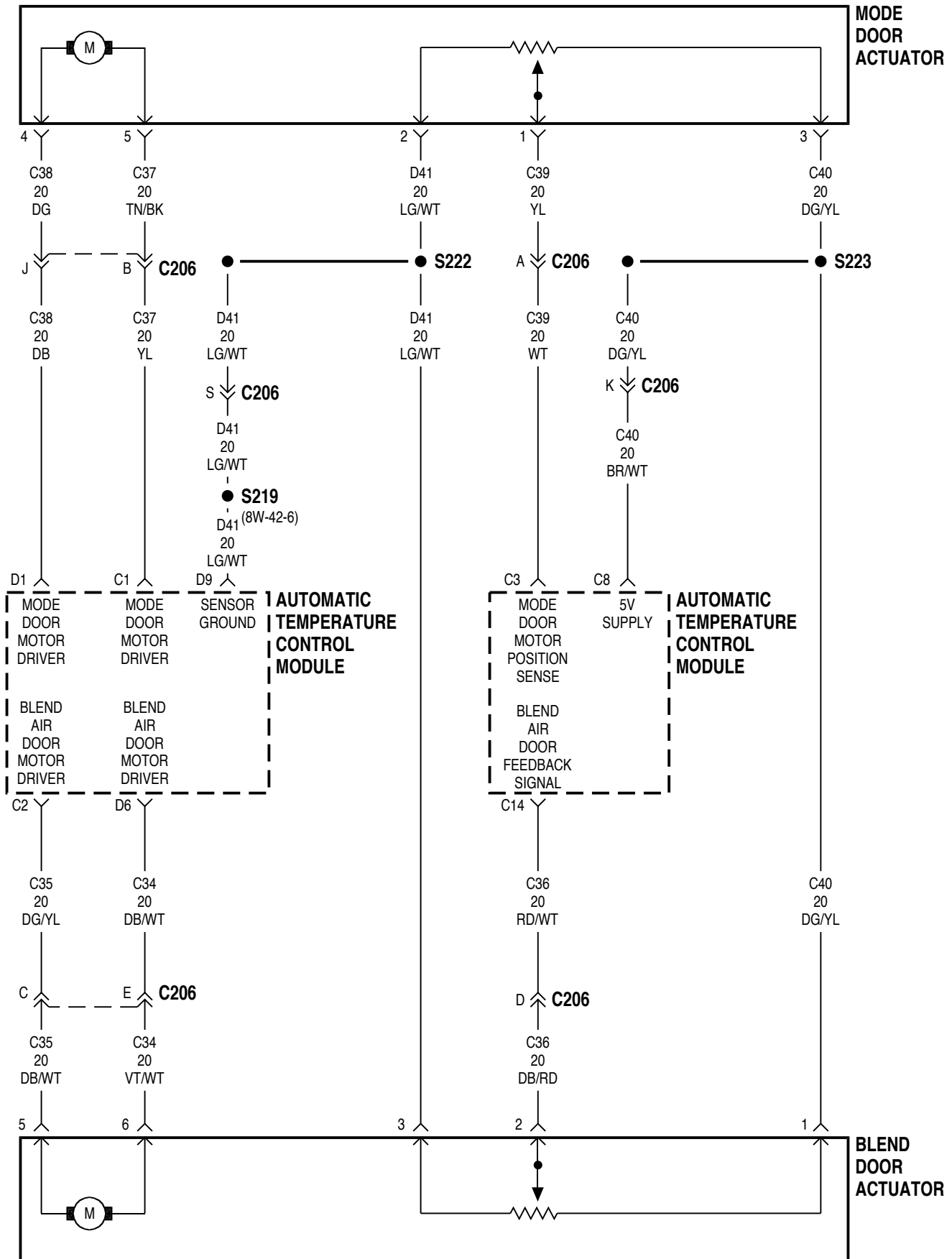


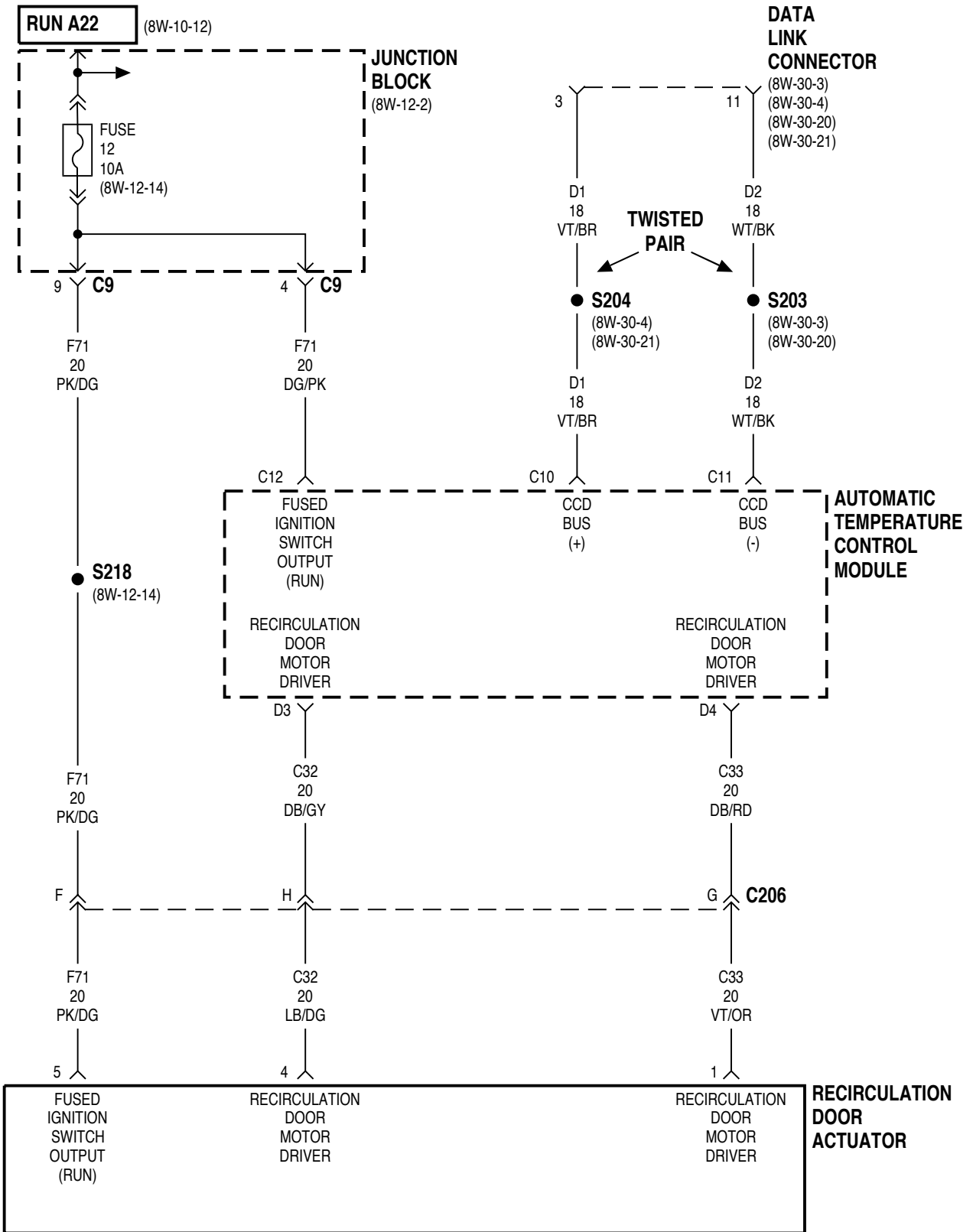


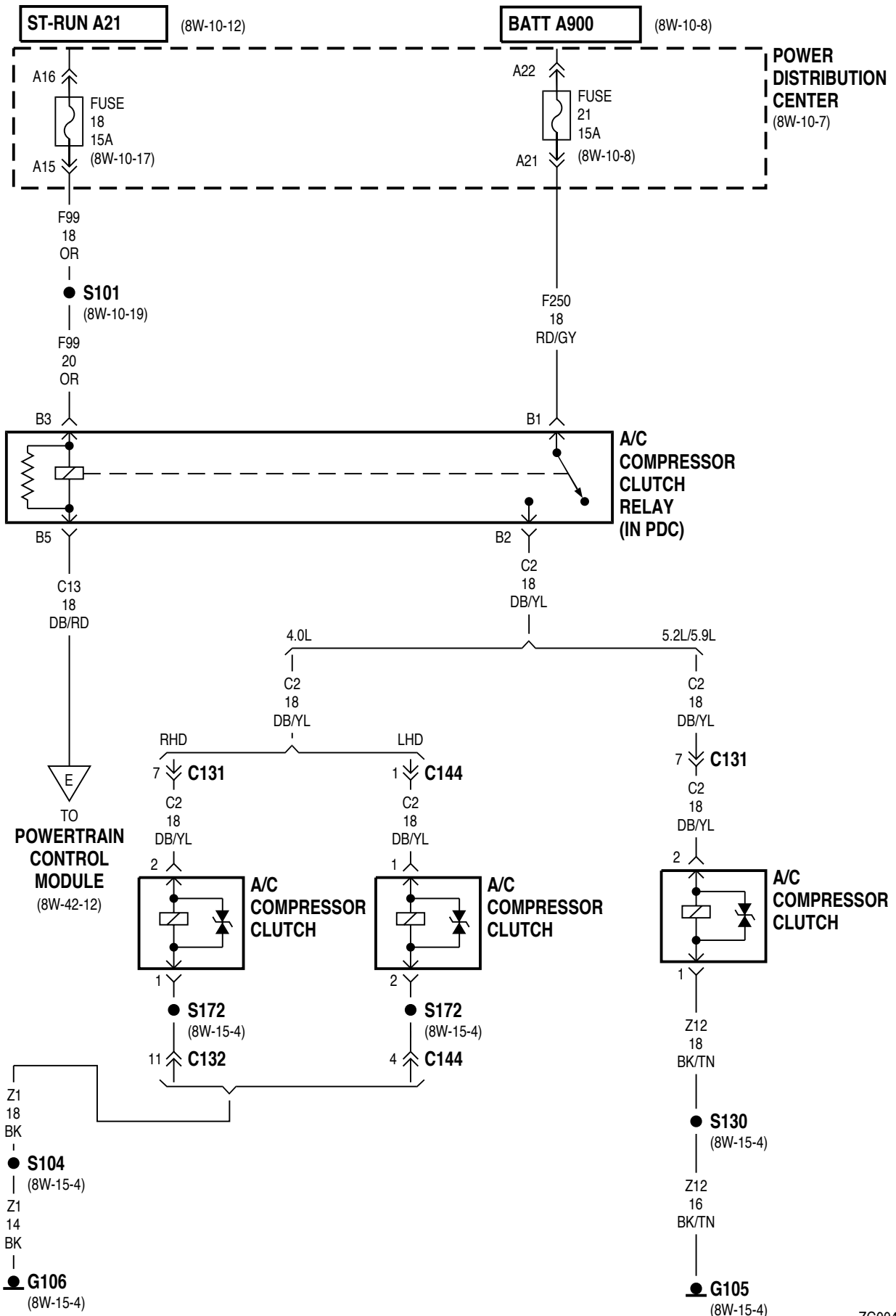


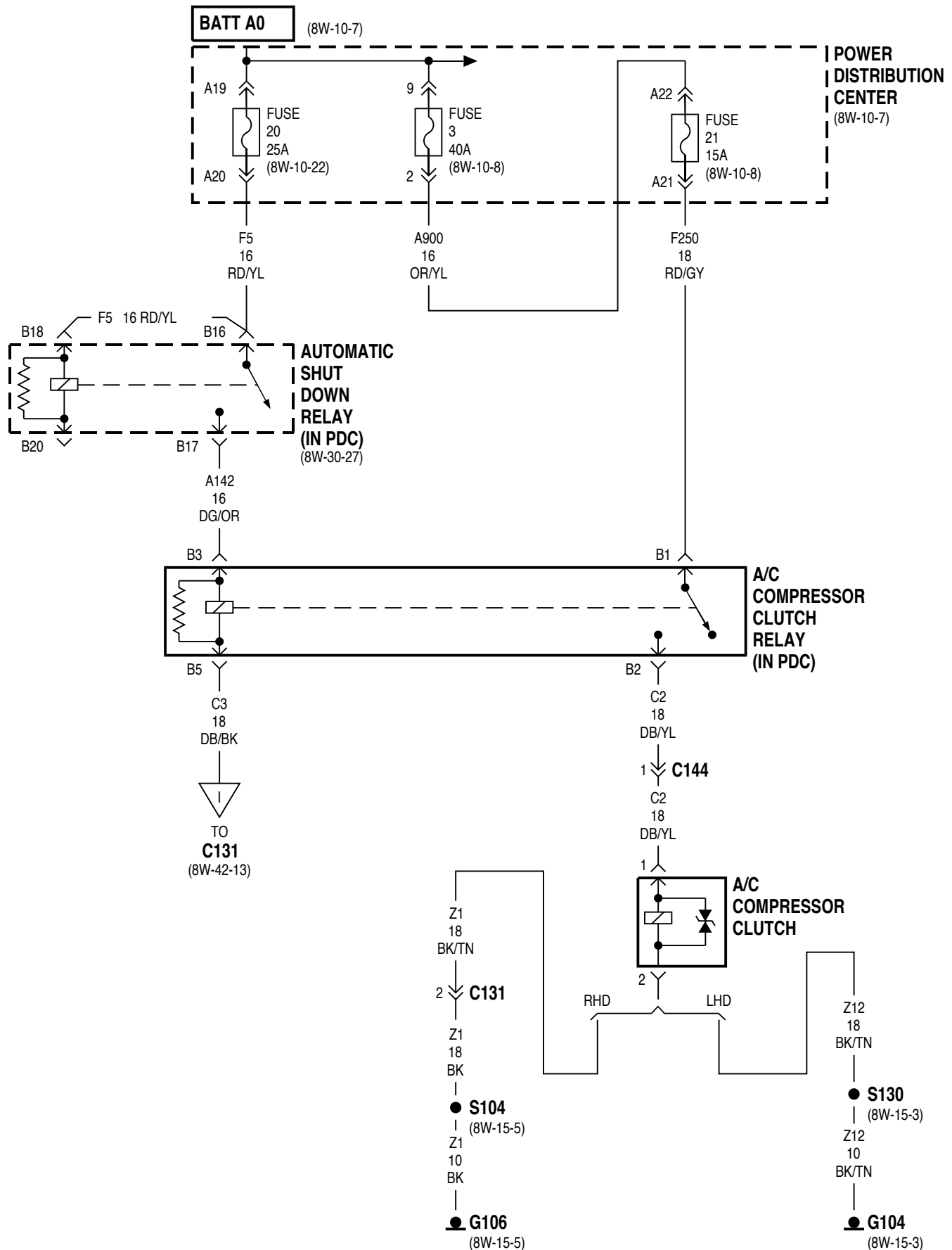


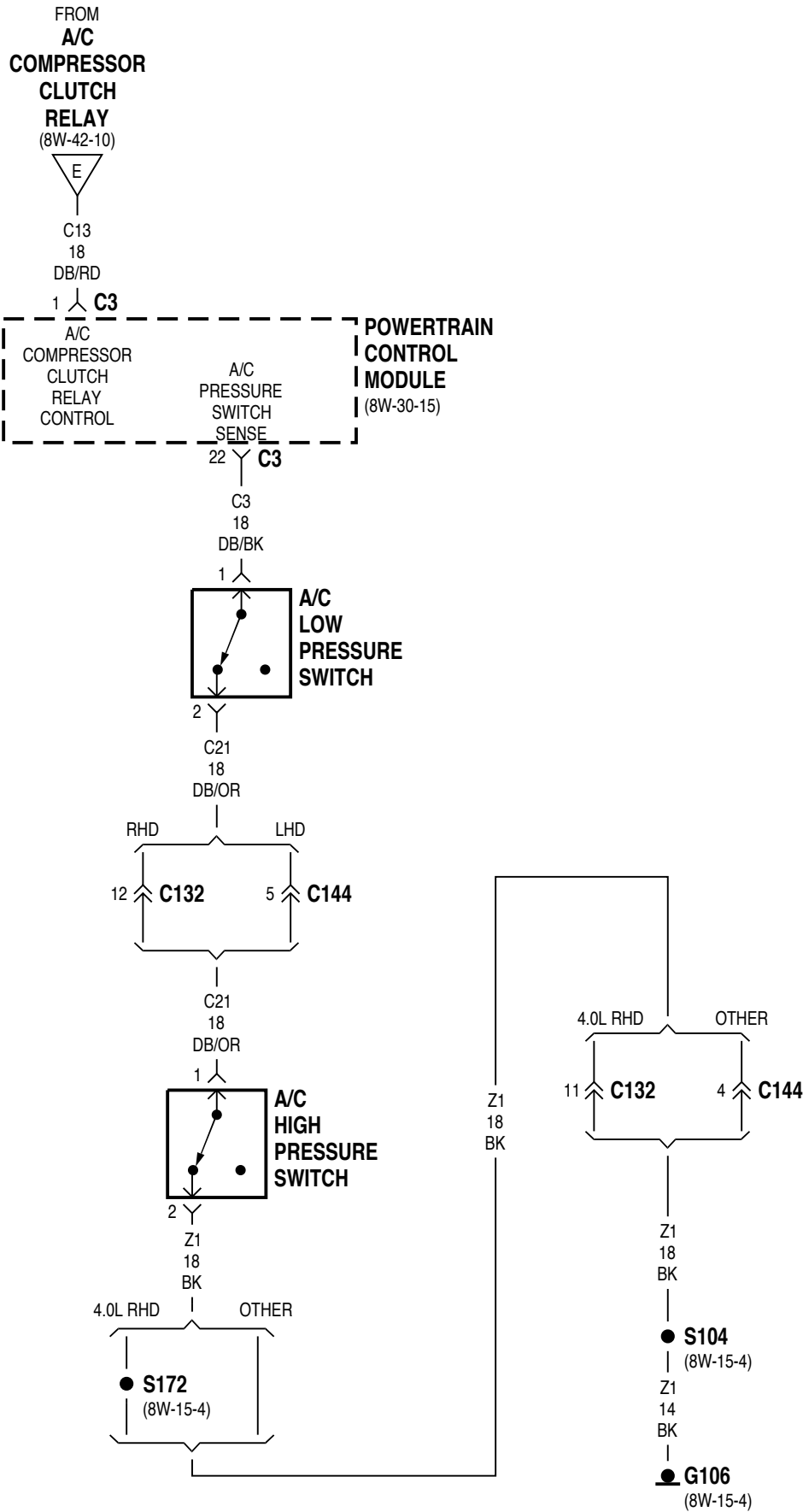


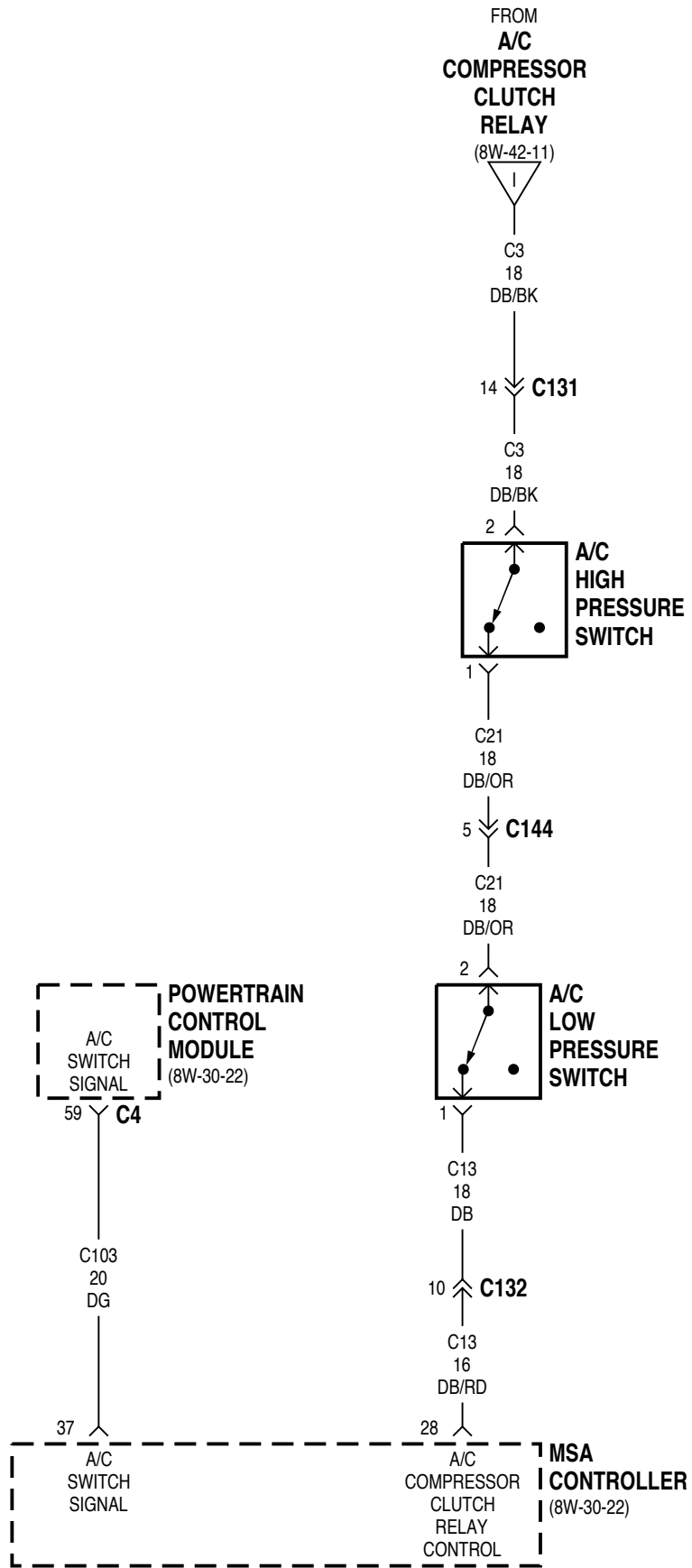






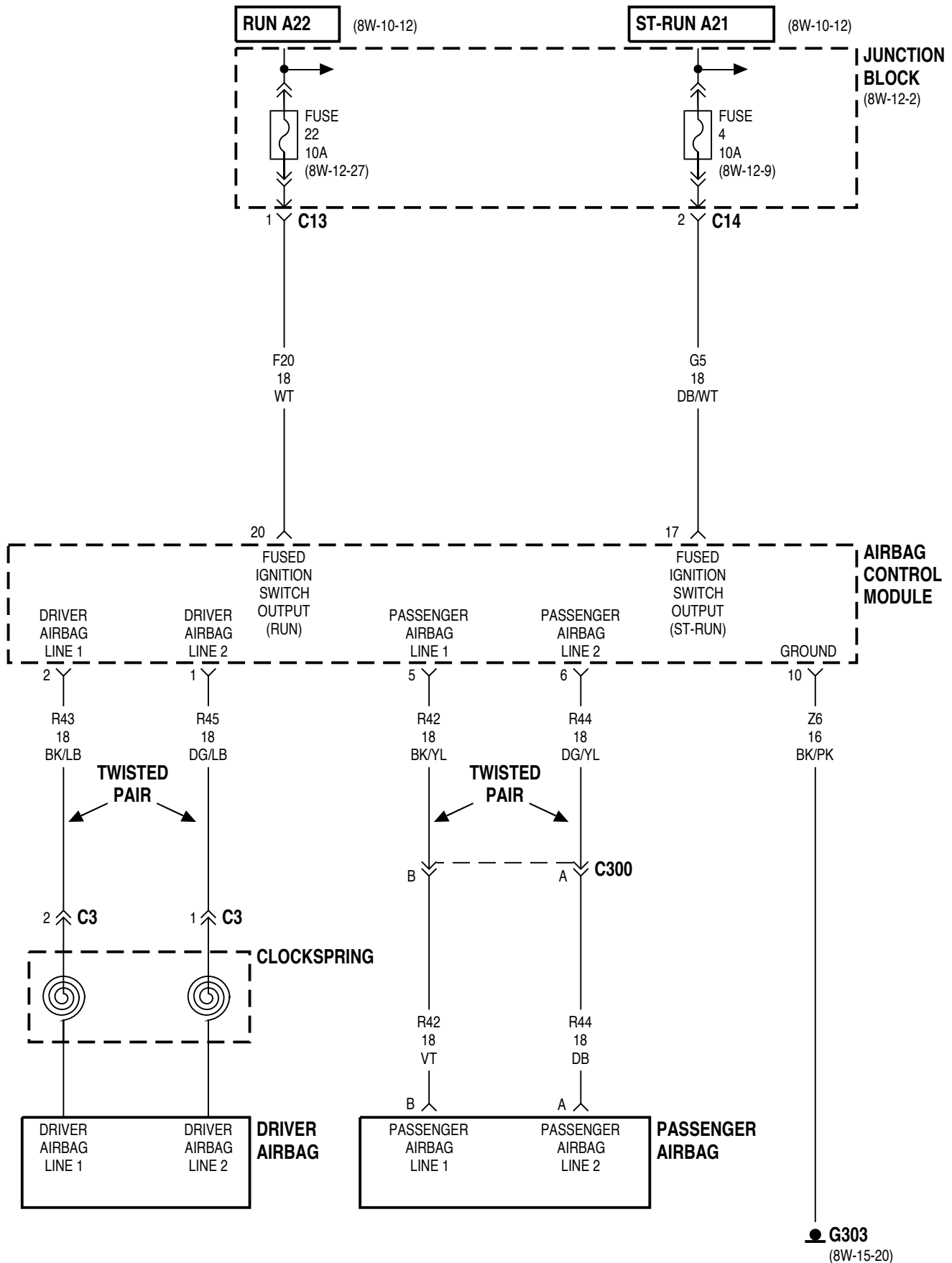


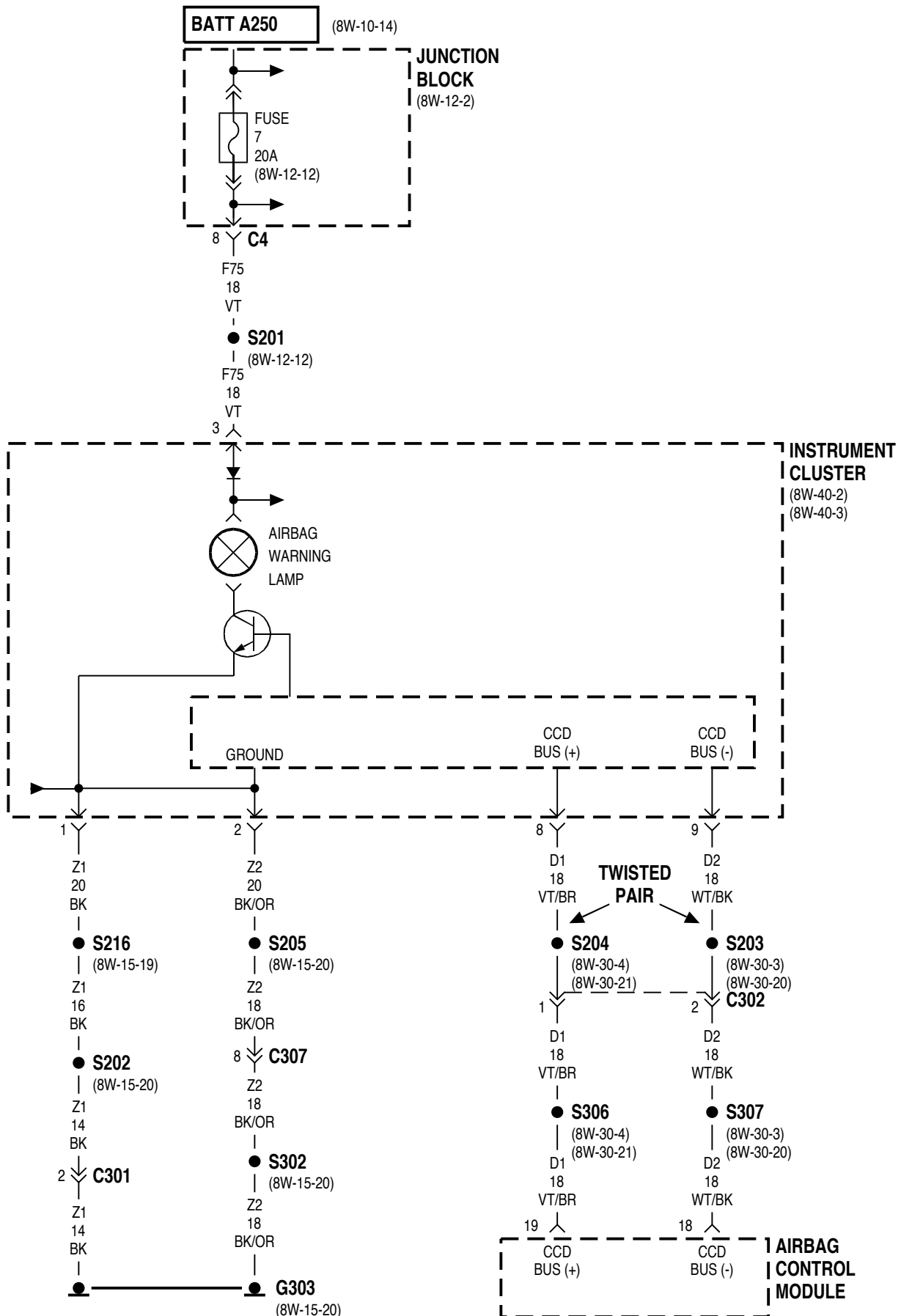




8W-43 AIRBAG SYSTEM

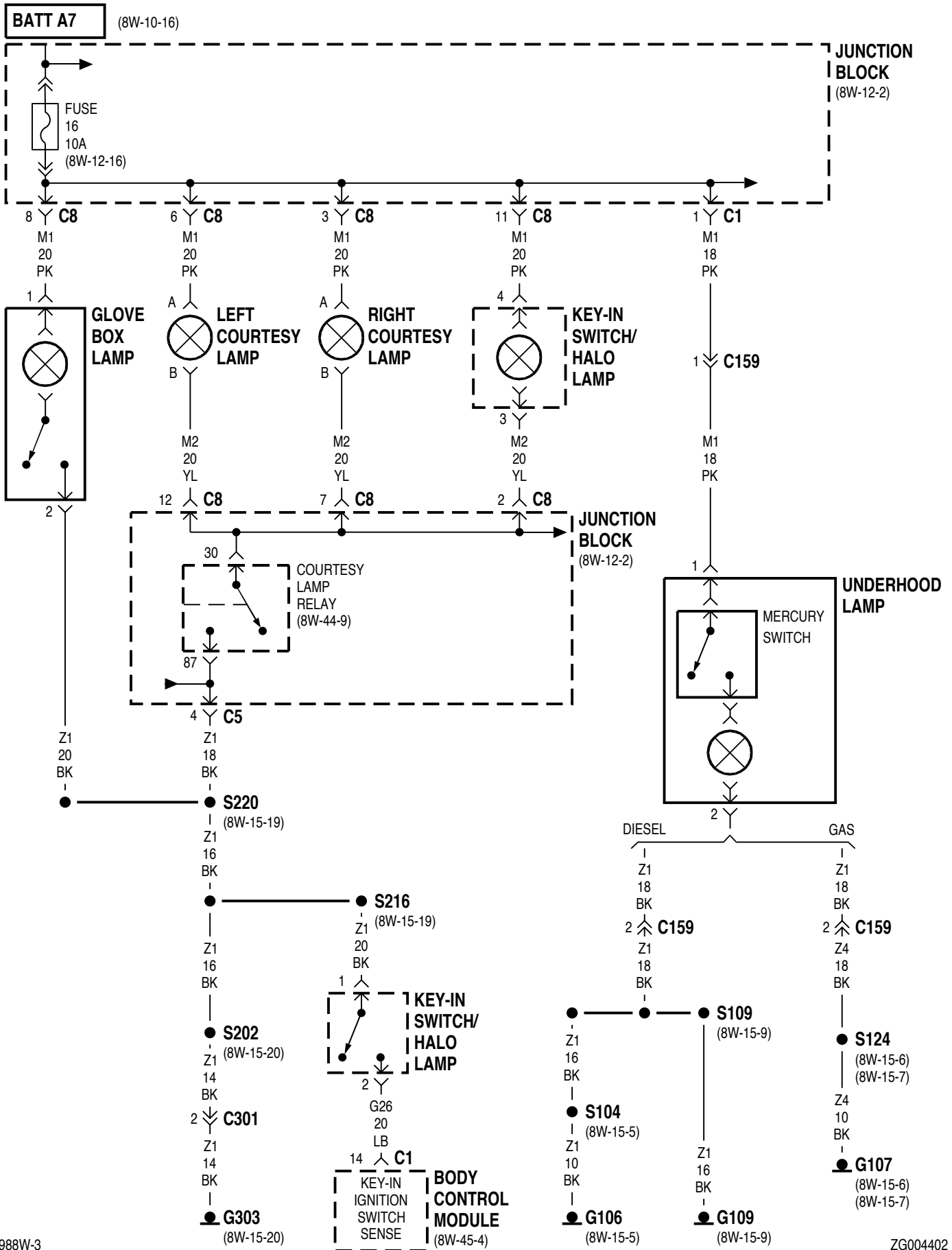
Component	Page	Component	Page
Airbag Control Module	8W-43-2, 3	Fuse 22 (JB)	8W-43-2
Airbag Warning Lamp	8W-43-3	G303	8W-43-2, 3
Clockspring	8W-43-2	Instrument Cluster	8W-43-3
Driver Airbag	8W-43-2	Junction Block	8W-43-2, 3
Fuse 4 (JB)	8W-43-2	Passenger Airbag	8W-43-2
Fuse 7 (JB)	8W-43-3		

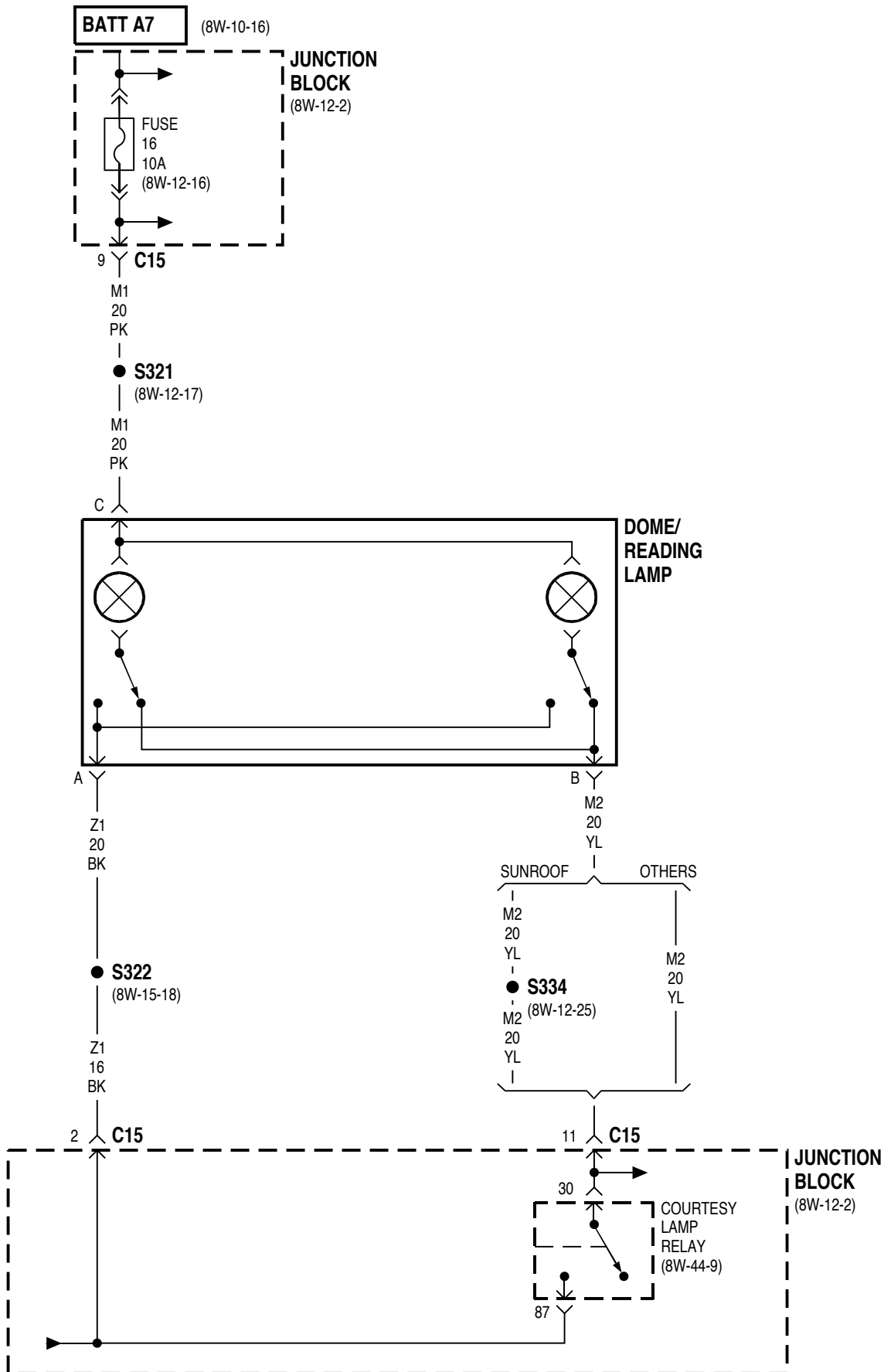


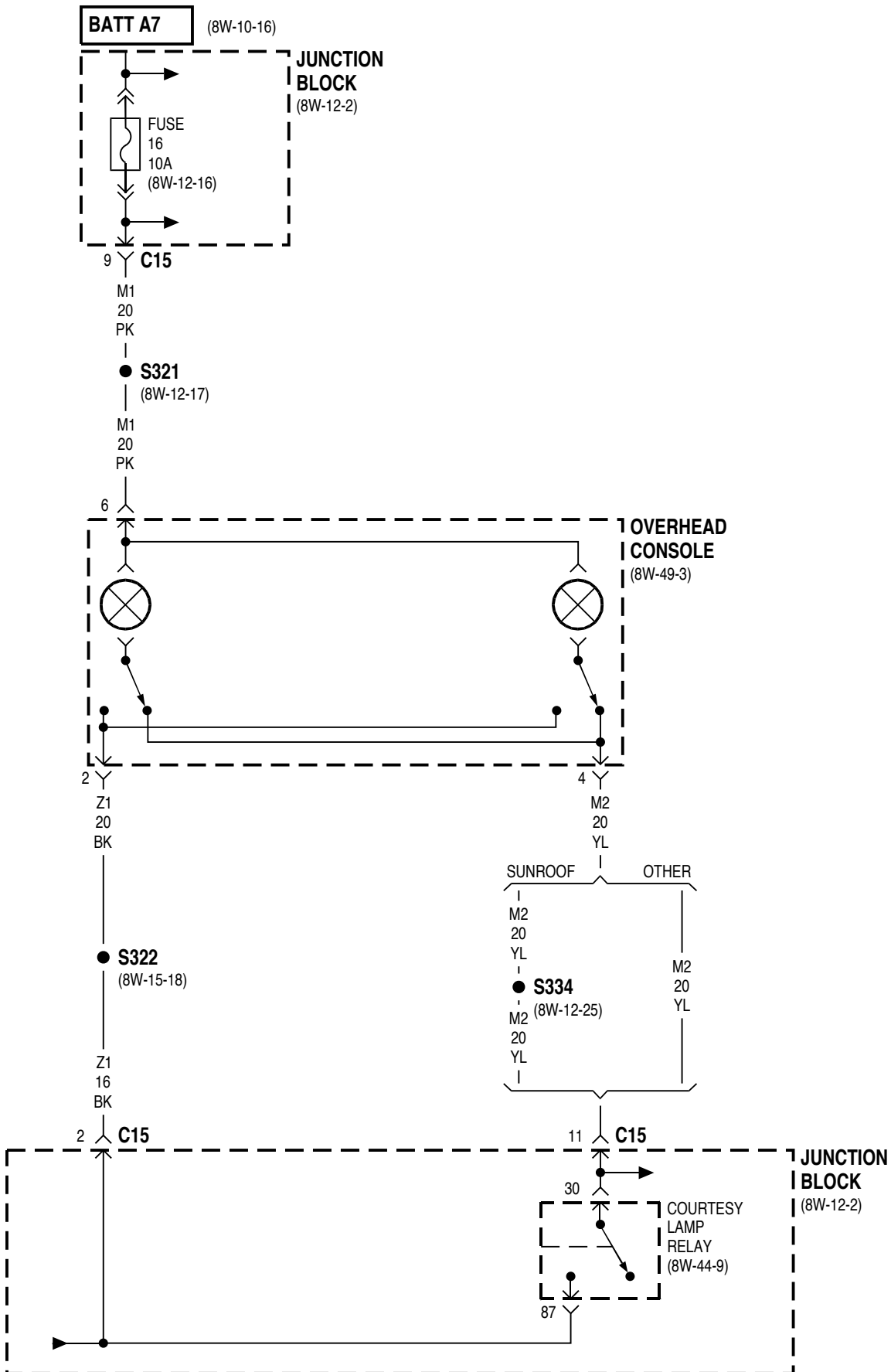


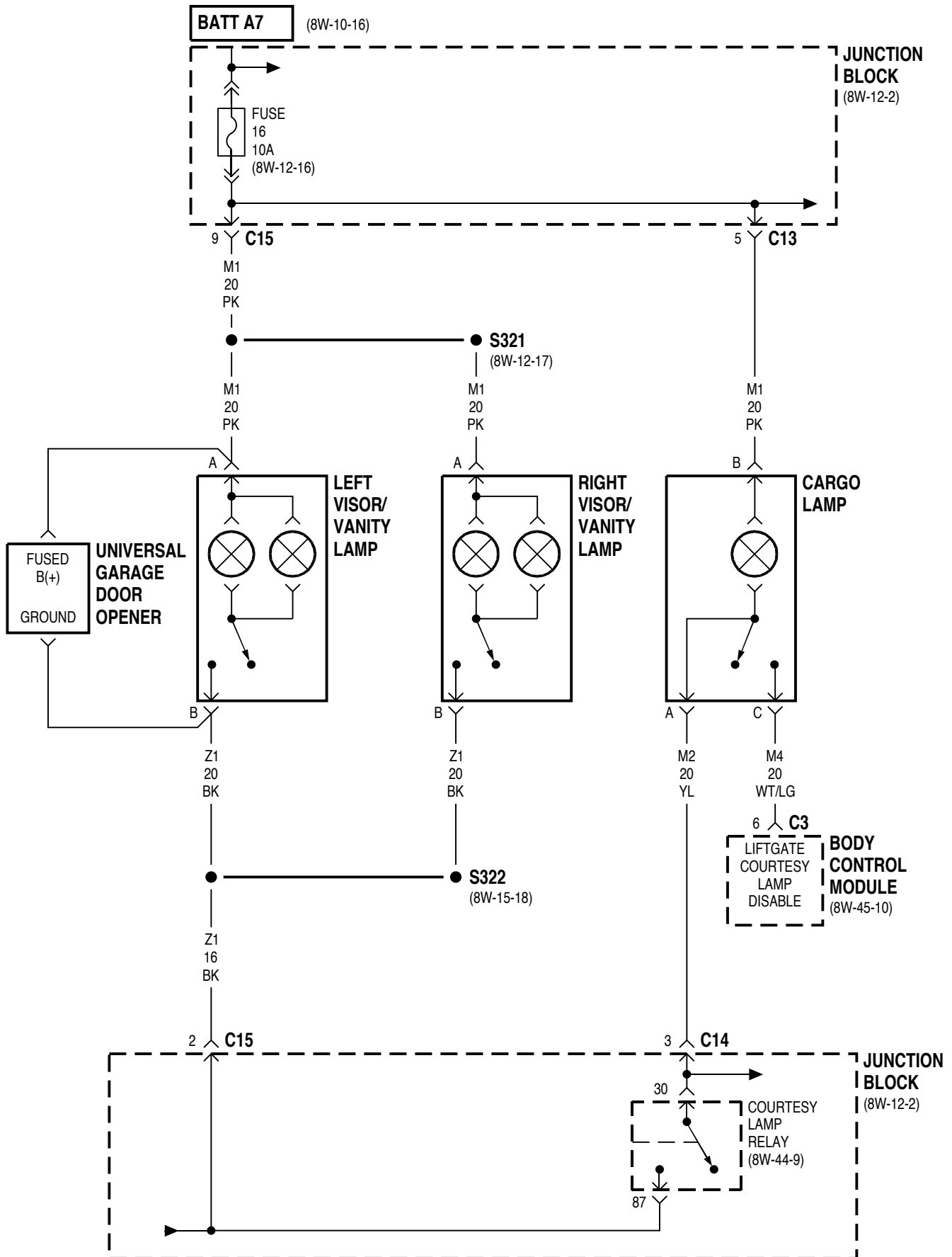
8W-44 INTERIOR LIGHTING

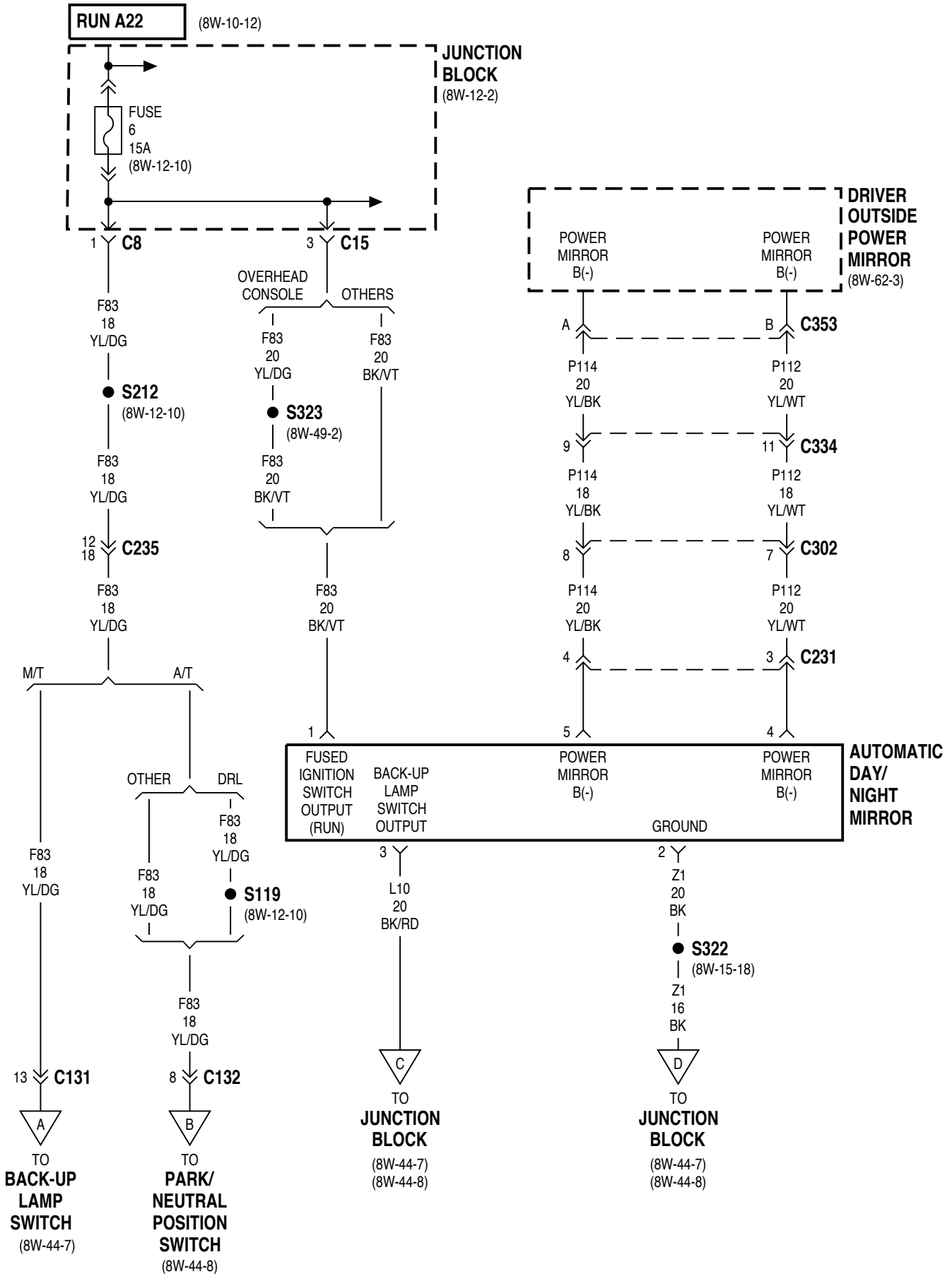
Component	Page	Component	Page
A/C Heater Control	8W-44-12	Glove Box Lamp	8W-44-2
Ash Receiver Lamp	8W-44-11, 12	Headlamp Switch	8W-44-11
Automatic Day/Night Mirror	8W-44-6	Instrument Cluster	8W-44-11
Automatic Temperature Control Module	8W-44-12	Junction Block	8W-44-2, 3, 4, 5, 6, 7, 8, 9, 10
Back-Up Lamp Switch	8W-44-7	Key-In Switch/Halo Lamp	8W-44-2
Body Control Module	8W-44-2, 5, 9, 11, 12, 13	Left Courtesy Lamp	8W-44-2, 9
Cargo Lamp	8W-44-5	Left Visor/Vanity Lamp	8W-44-5
Cigar Lighter Lamp	8W-44-12	Liftgate Ajar Switch	8W-44-13
Cigar Lighter/Power Outlet	8W-44-12	Liftglass Ajar Switch	8W-44-13
Circuit Breaker 2	8W-44-10	Mercury Switch	8W-44-2
Courtesy Lamp Relay	8W-44-2, 3, 4, 5, 9	Overhead Console	8W-44-4
Dome/Reading Lamp	8W-44-3	Park/Neutral Position Switch	8W-44-8
Driver Door Courtesy Lamp	8W-44-10	Passenger Door Courtesy Lamp	8W-44-10
Driver Door Module	8W-44-10	Passenger Door Module	8W-44-10
Driver Front Door Ajar Switch	8W-44-13	Passenger Front Door Ajar Switch	8W-44-13
Driver Outside Power Mirror	8W-44-6	Passenger Rear Door Ajar Switch	8W-44-13
Driver Rear Door Ajar Switch	8W-44-13	Powertrain Control Module	8W-44-8
Floor Console Lamps	8W-44-11	Radio	8W-44-9
Fuse 6 (JB)	8W-44-6	Right Courtesy Lamp	8W-44-2, 9
Fuse 16 (JB)	8W-44-2, 3, 4, 5, 9	Right Visor/Vanity Lamp	8W-44-5
G107	8W-44-2	Switch Pod	8W-44-11
G109	8W-44-2	Underhood Lamp	8W-44-2
G300	8W-44-13	Universal Garage Door Opener	8W-44-5
G301	8W-44-10	Vehicle Information Center/ Graphic Display Module	8W-44-12
G302	8W-44-10, 11		
G303	8W-44-2, 7, 8, 9, 11, 12		

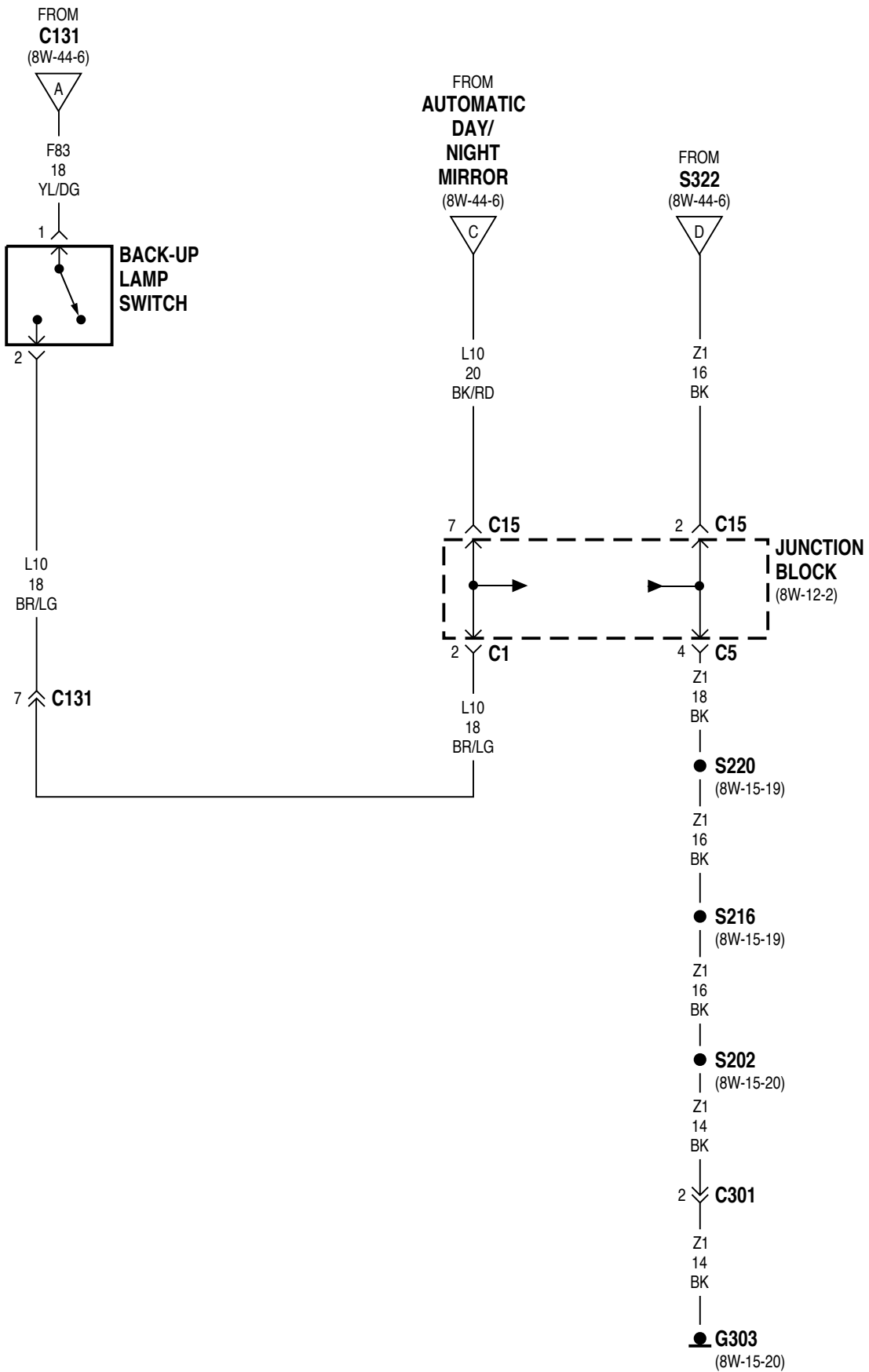


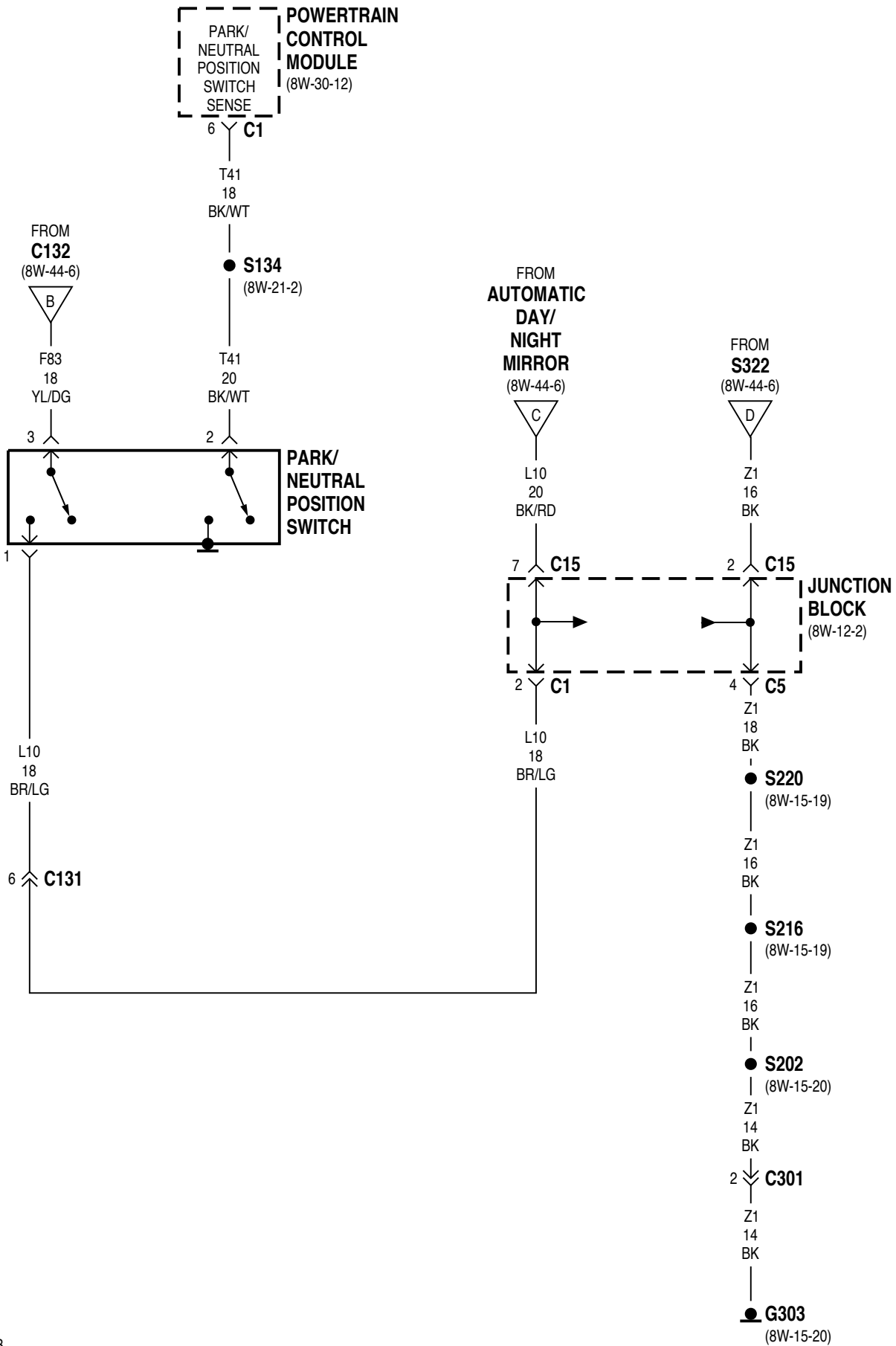


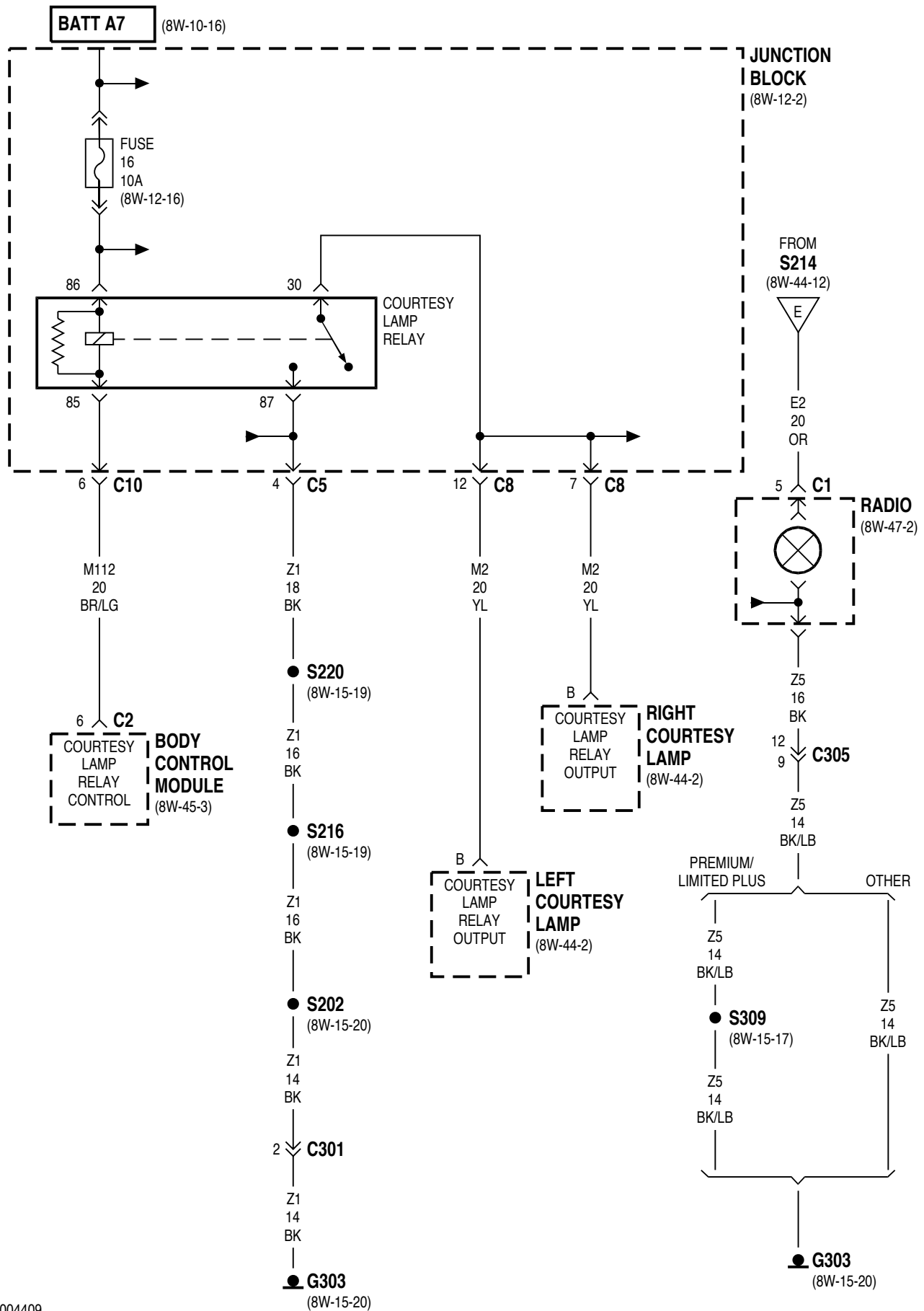


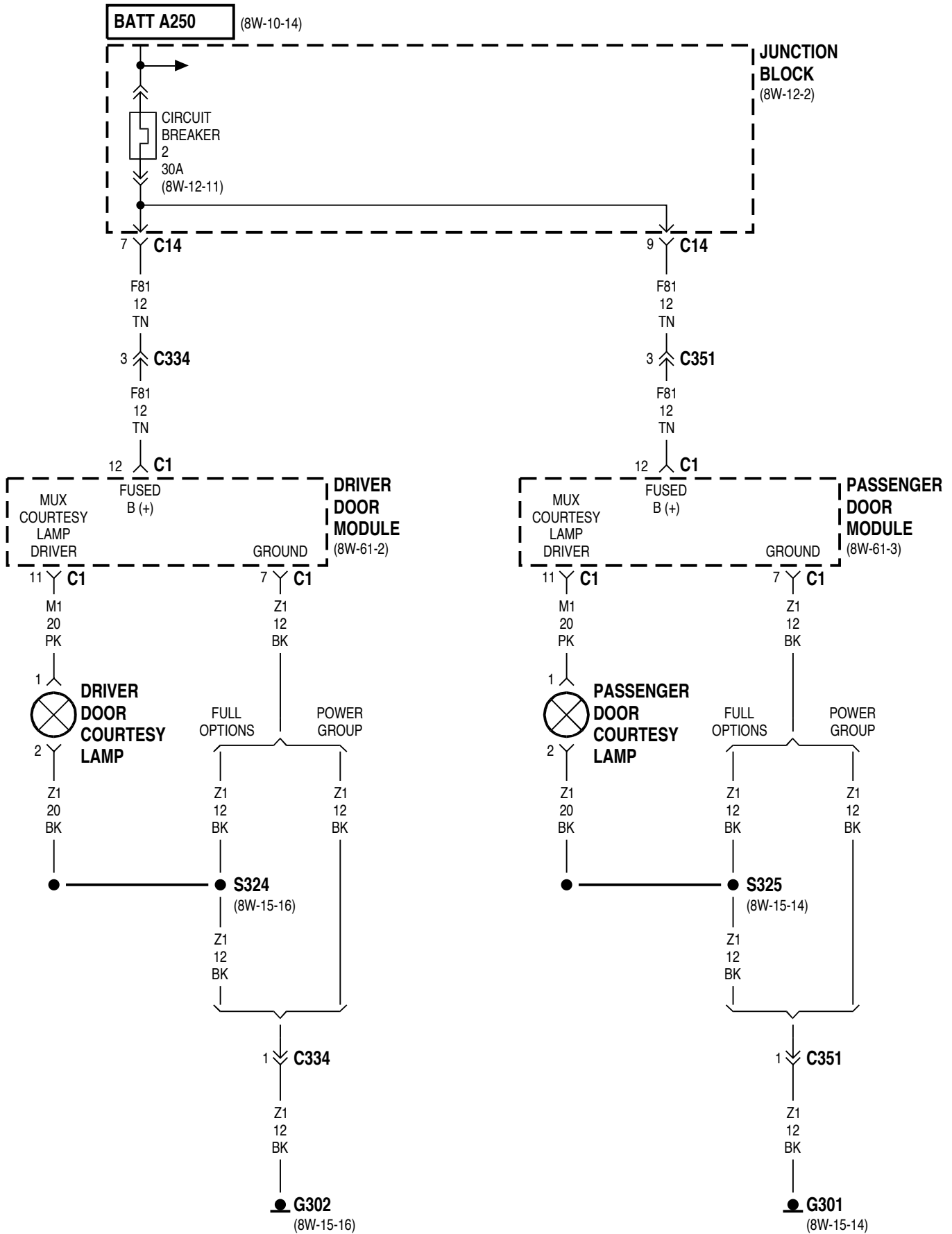


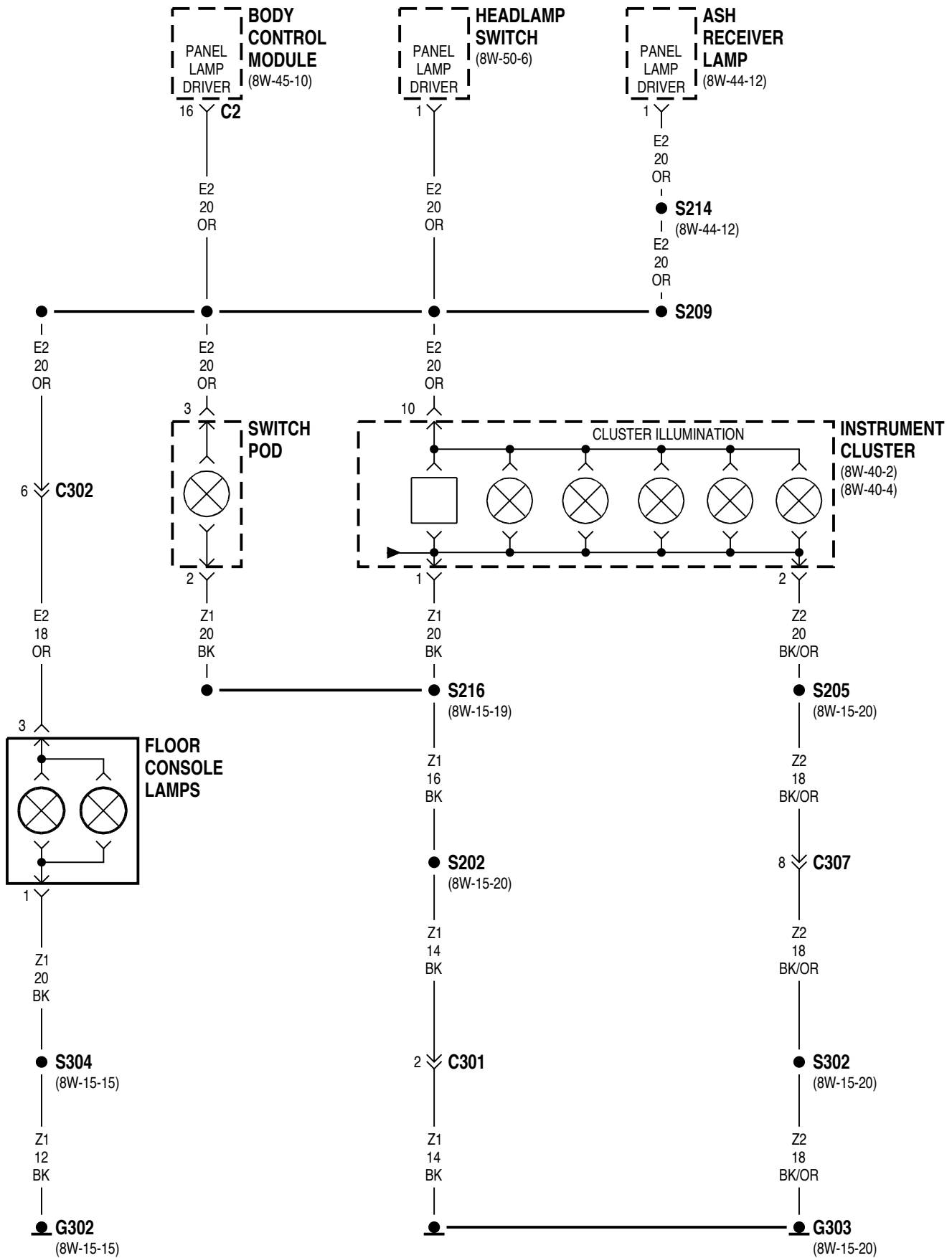


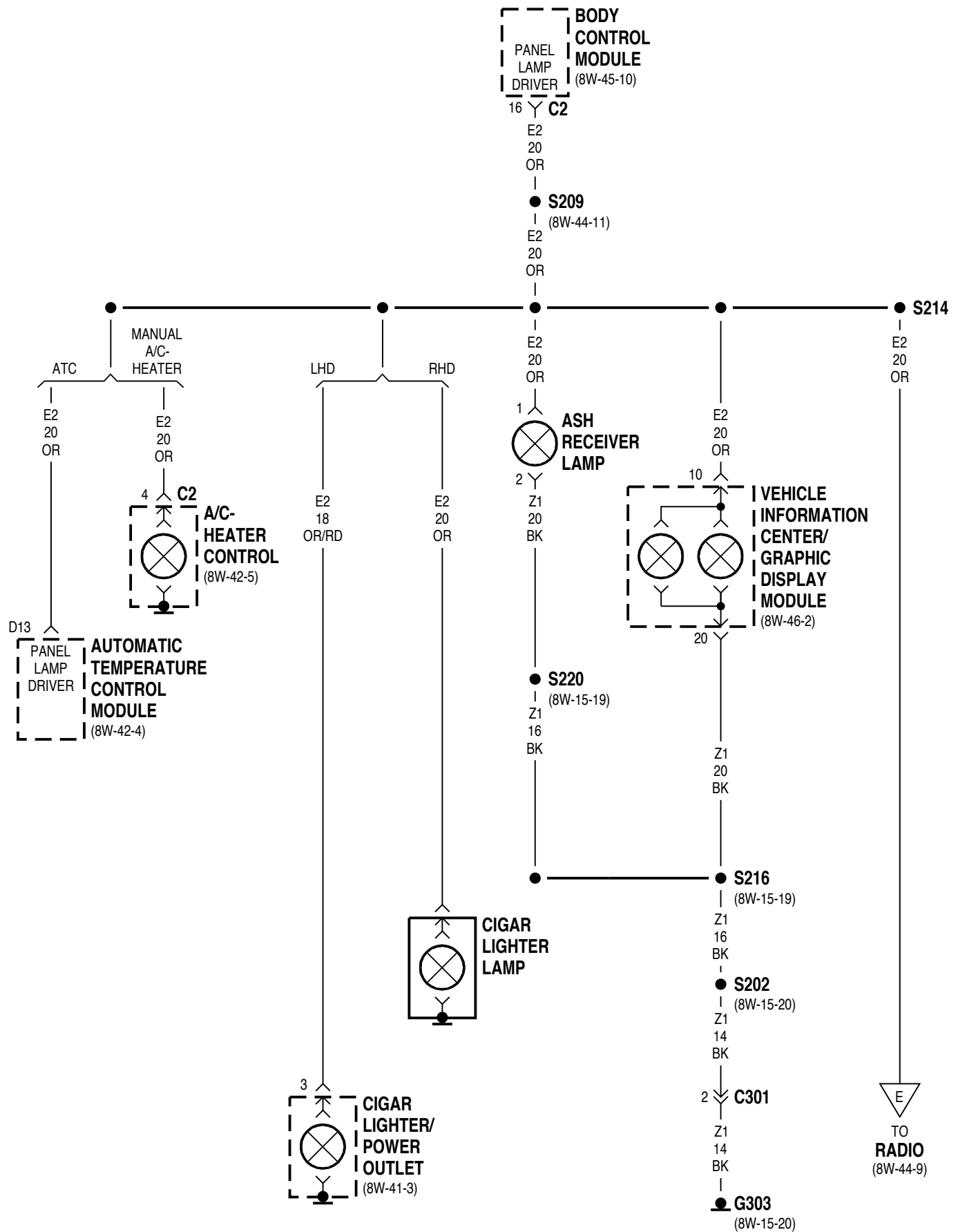


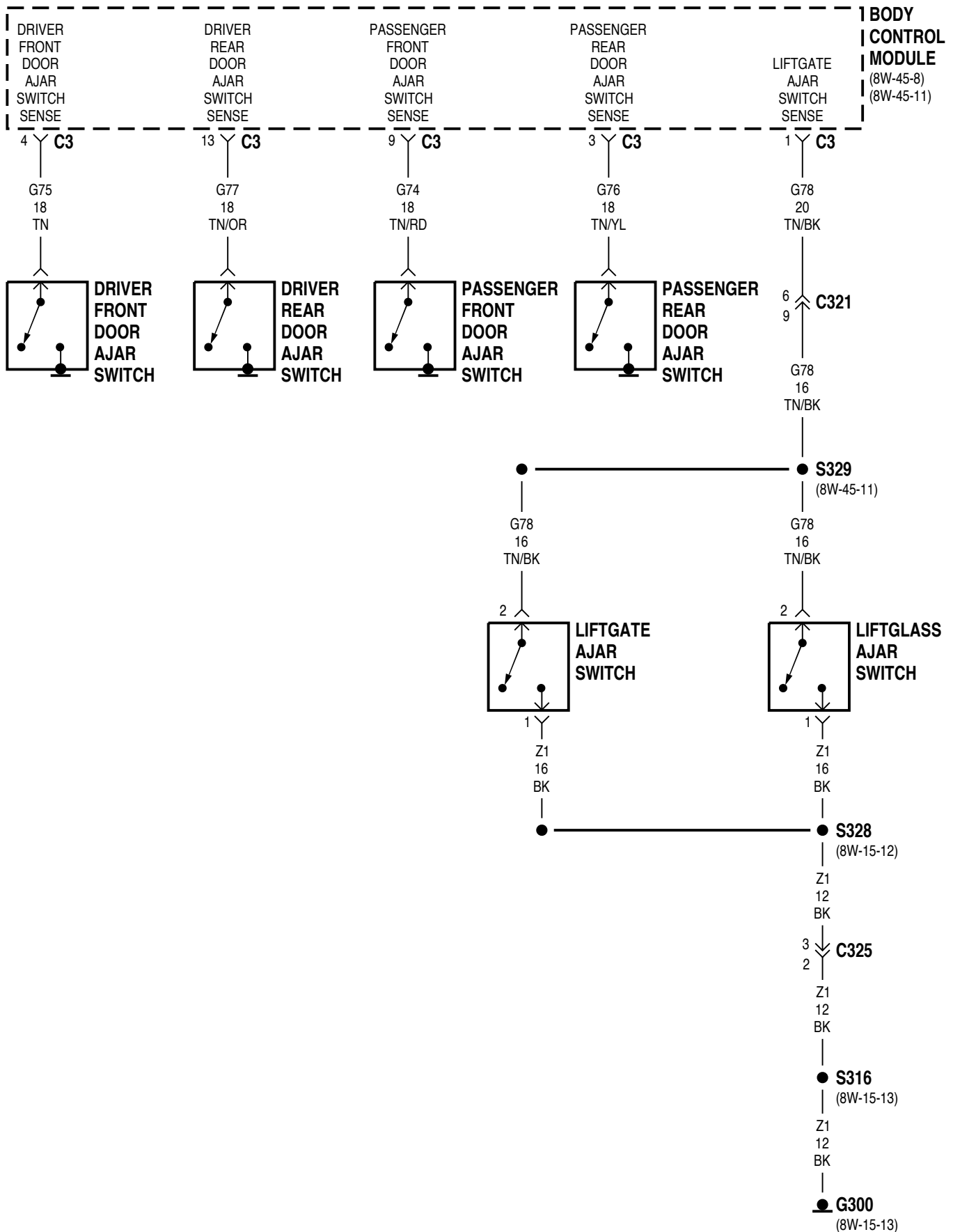






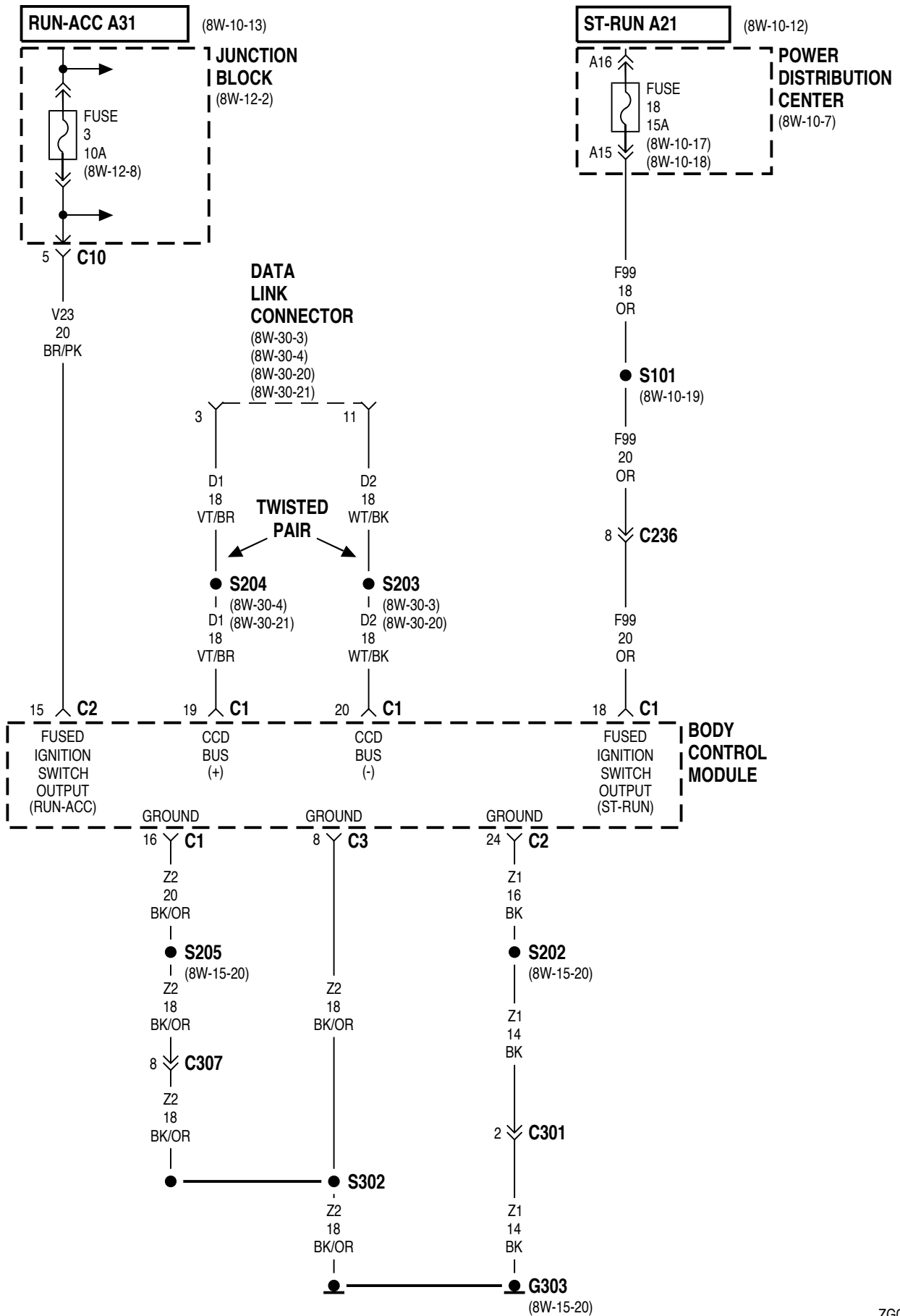


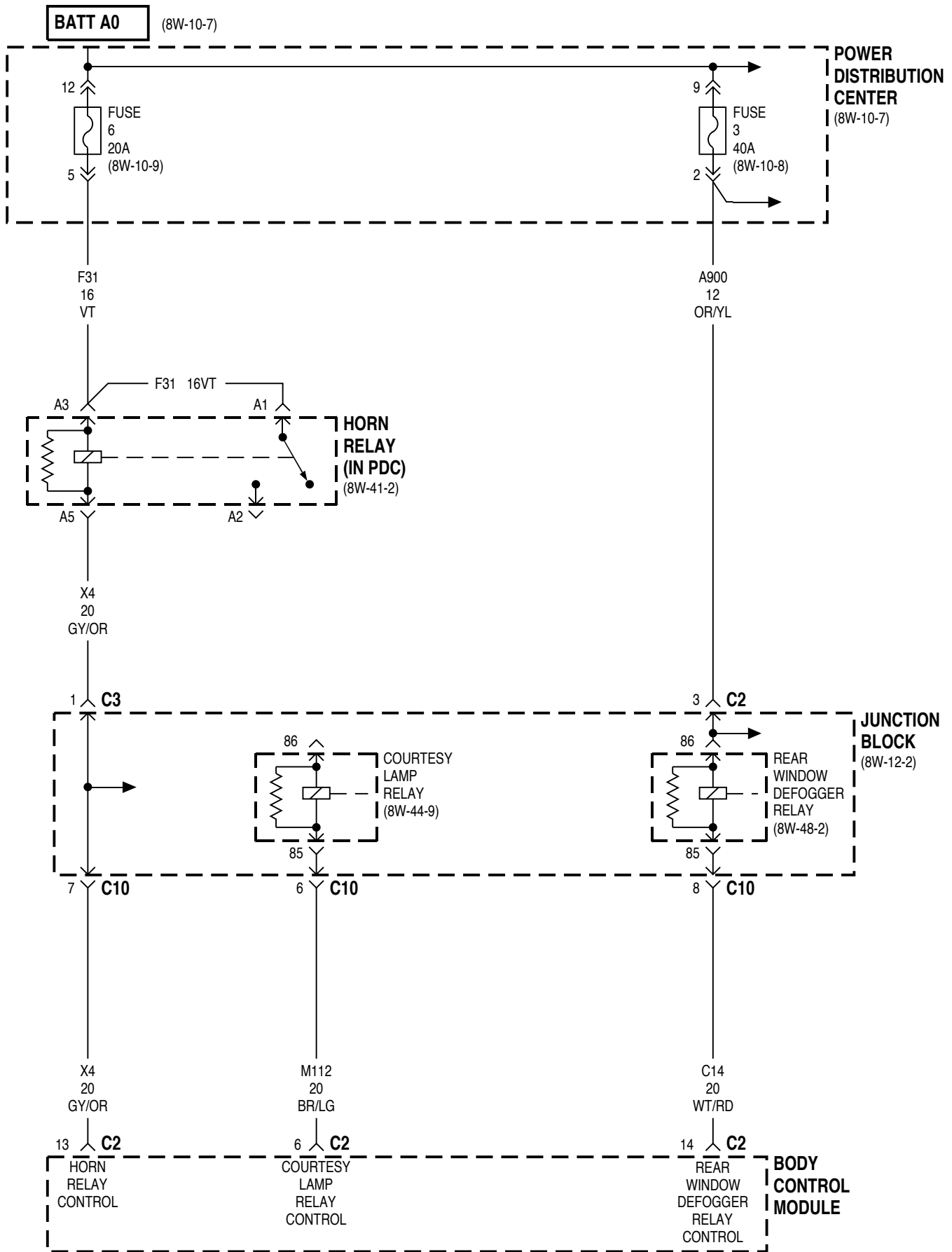


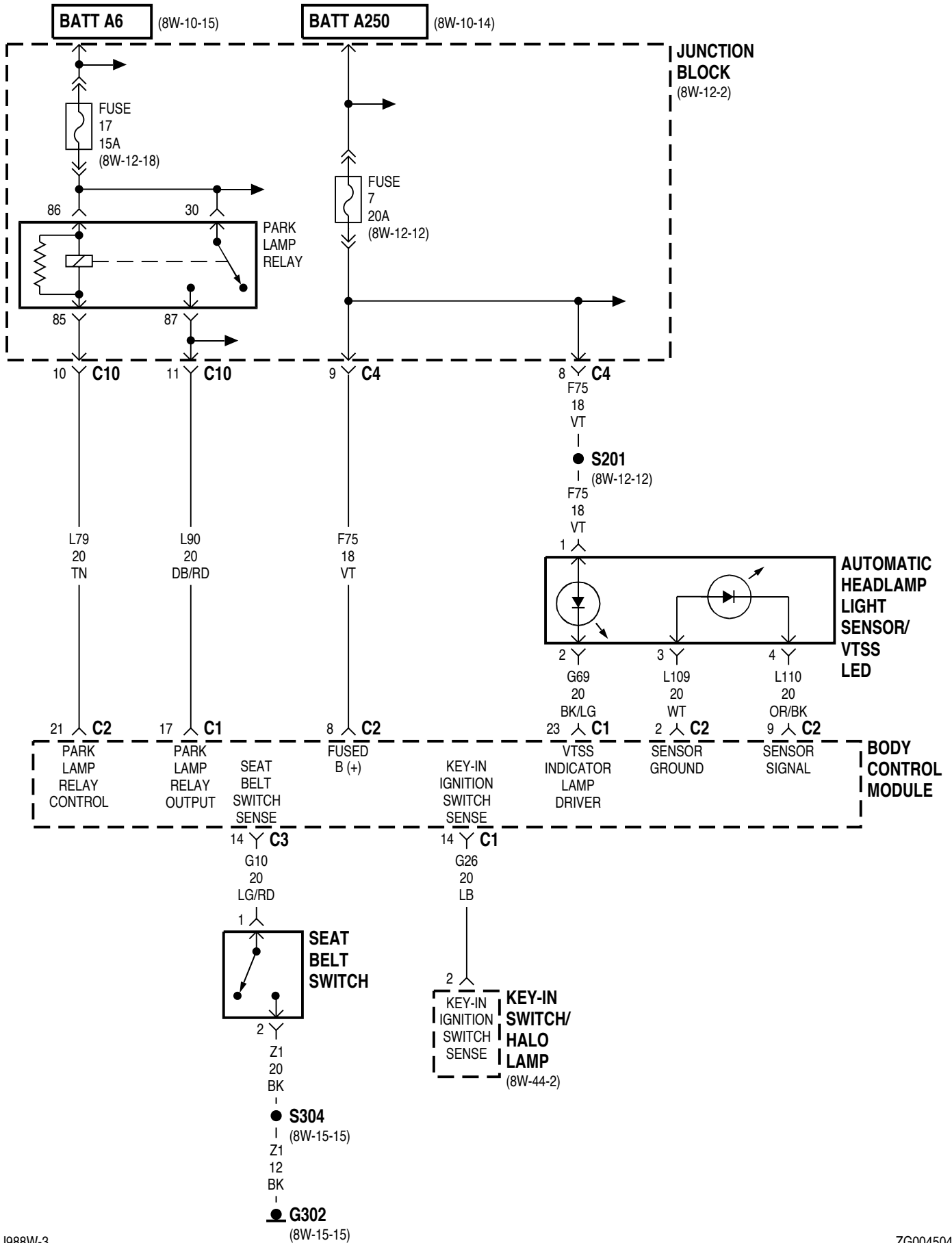


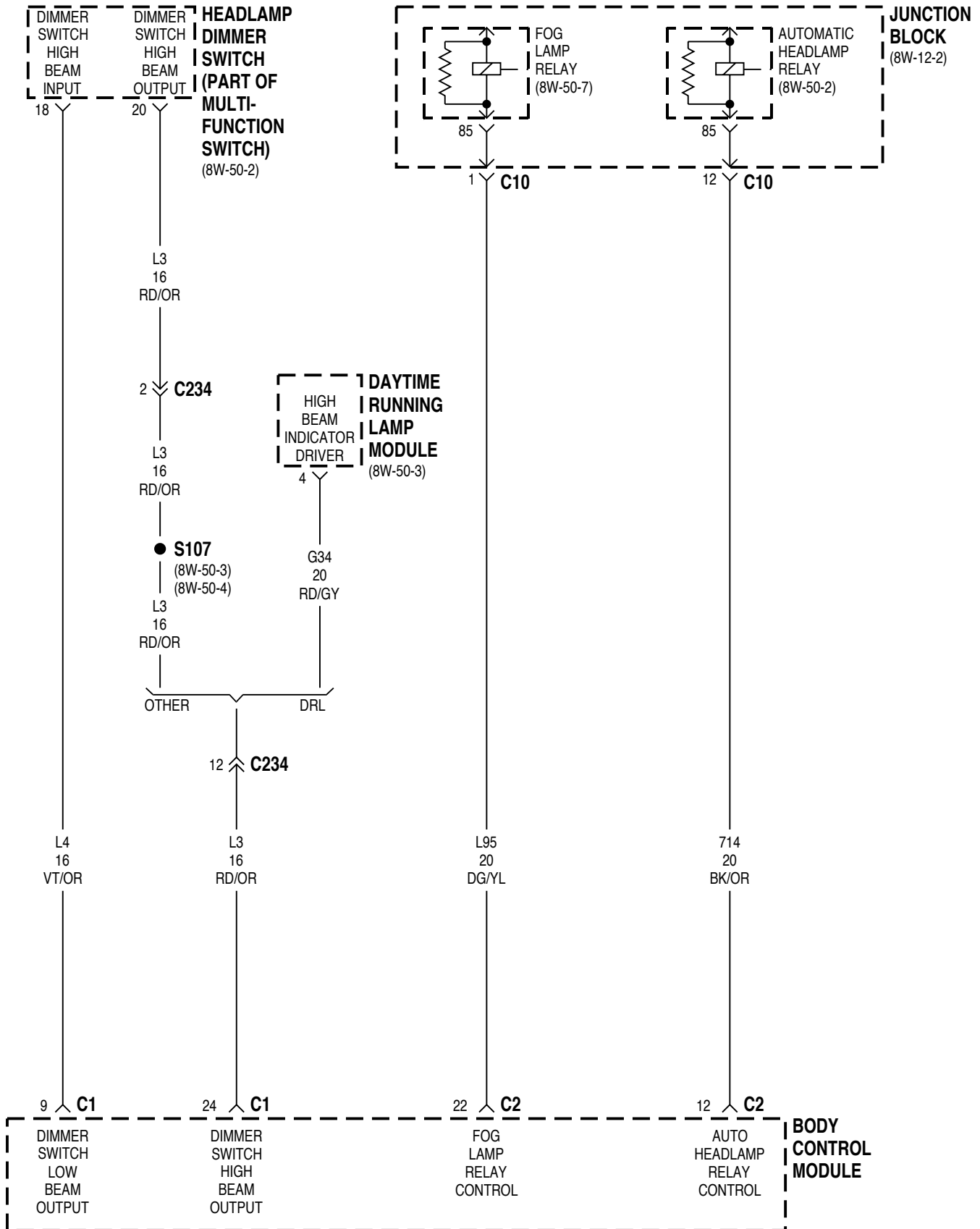
8W-45 BODY CONTROL MODULE

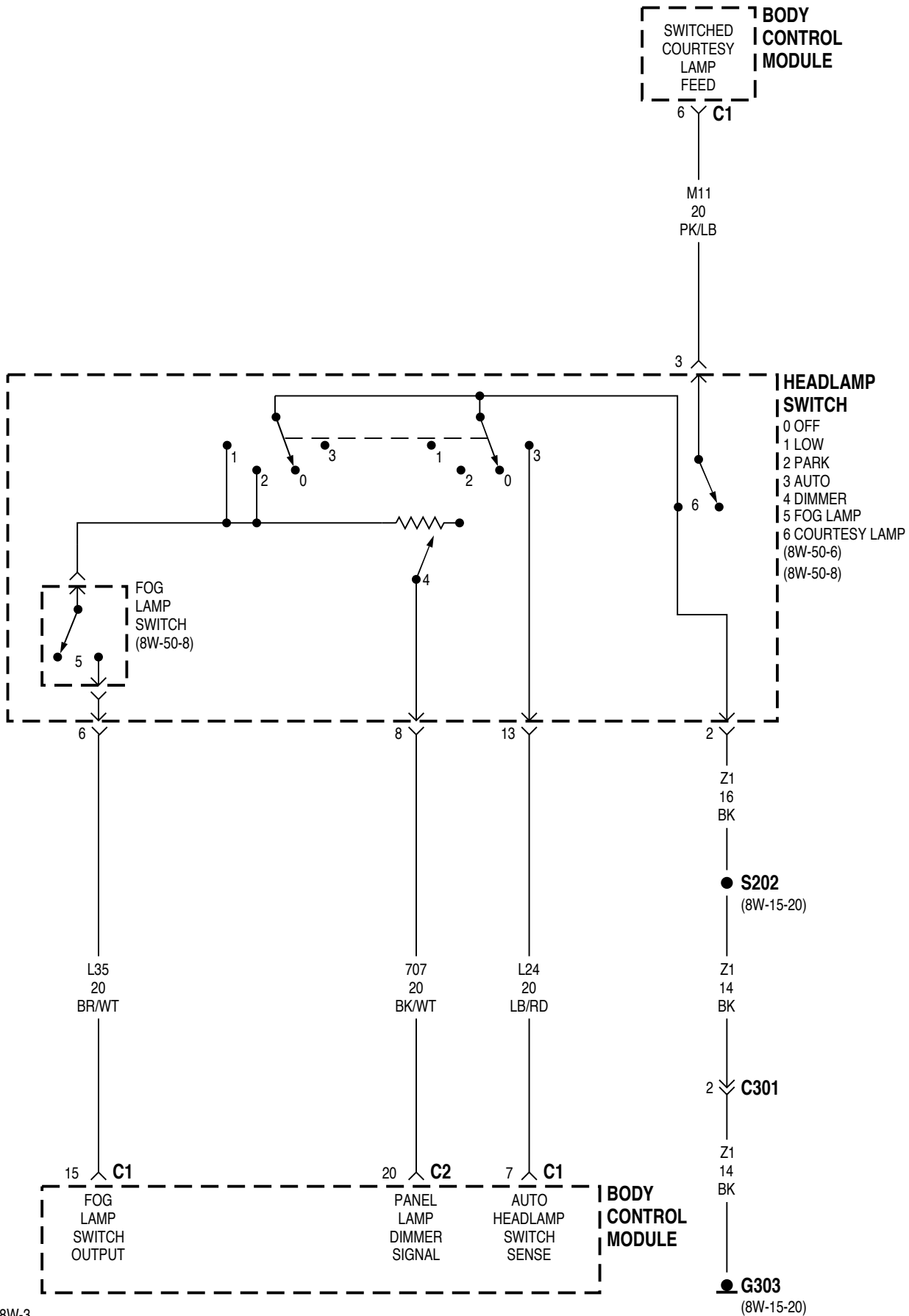
Component	Page	Component	Page
A/C Heater Control	8W-45-9	G300	8W-45-11
Ambient Temperature Sensor	8W-45-9	G302	8W-45-4
Ash Receiver Lamp	8W-45-10	G303	8W-45-2, 6
Automatic Headlamp Light Sensor/ Vtss Led	8W-45-4	Headlamp Dimmer Switch	8W-45-5
Automatic Headlamp Relay	8W-45-5	Headlamp Switch	8W-45-6
Automatic Temperature Control Module	8W-45-9	Hood Switch	8W-45-10
Body Control Module . .8W-45-2, 3, 4, 5, 6, 7, 8, 9, 10		Horn Relay	8W-45-3
Brake Pressure Switch	8W-45-9	Instrument Cluster	8W-45-10
Cargo Lamp	8W-45-10	Intermittent Wiper Relay	8W-45-7
Circuit Breaker 1	8W-45-7	Intermittent Wiper Switch	8W-45-7
Clockspring	8W-45-7	Junction Block.	8W-45-2, 3, 4, 5, 7
Courtesy Lamp Relay	8W-45-3	Key-In Switch/Halo Lamp.	8W-45-4
Data Link Connector	8W-45-2	Liftgate Ajar Switch	8W-45-11
Daytime Running Lamp Module	8W-45-5	Liftgate Cylinder Lock Switch	8W-45-8
Driver Front Cylinder Lock Switch.	8W-45-8	Liftglass Ajar Switch.	8W-45-11
Driver Front Door Ajar Switch	8W-45-8	Park Brake Switch	8W-45-9
Driver Rear Door Ajar Switch.	8W-45-8	Park Lamp Relay	8W-45-4
Floor Console Lamps.	8W-45-10	Passenger Front Cylinder Lock Switch.	8W-45-8
Fog Lamp Relay	8W-45-5	Passenger Front Door Ajar Switch	8W-45-8
Fog Lamp Switch	8W-45-6	Passenger Rear Door Ajar Switch	8W-45-8
Fuse 3 (JB)	8W-45-2	Power Distribution Center	8W-45-2, 3
Fuse 3 (PDC)	8W-45-3	Rear Window Defogger Relay	8W-45-3
Fuse 6 (PDC)	8W-45-3	Rear Window Defogger Switch	8W-45-9
Fuse 7 (JB)	8W-45-4	Rear Wiper Module	8W-45-11
Fuse 17 (JB)	8W-45-4	Seat Belt Switch	8W-45-4
Fuse 18 (PDC)	8W-45-2	Switch Pod	8W-45-10

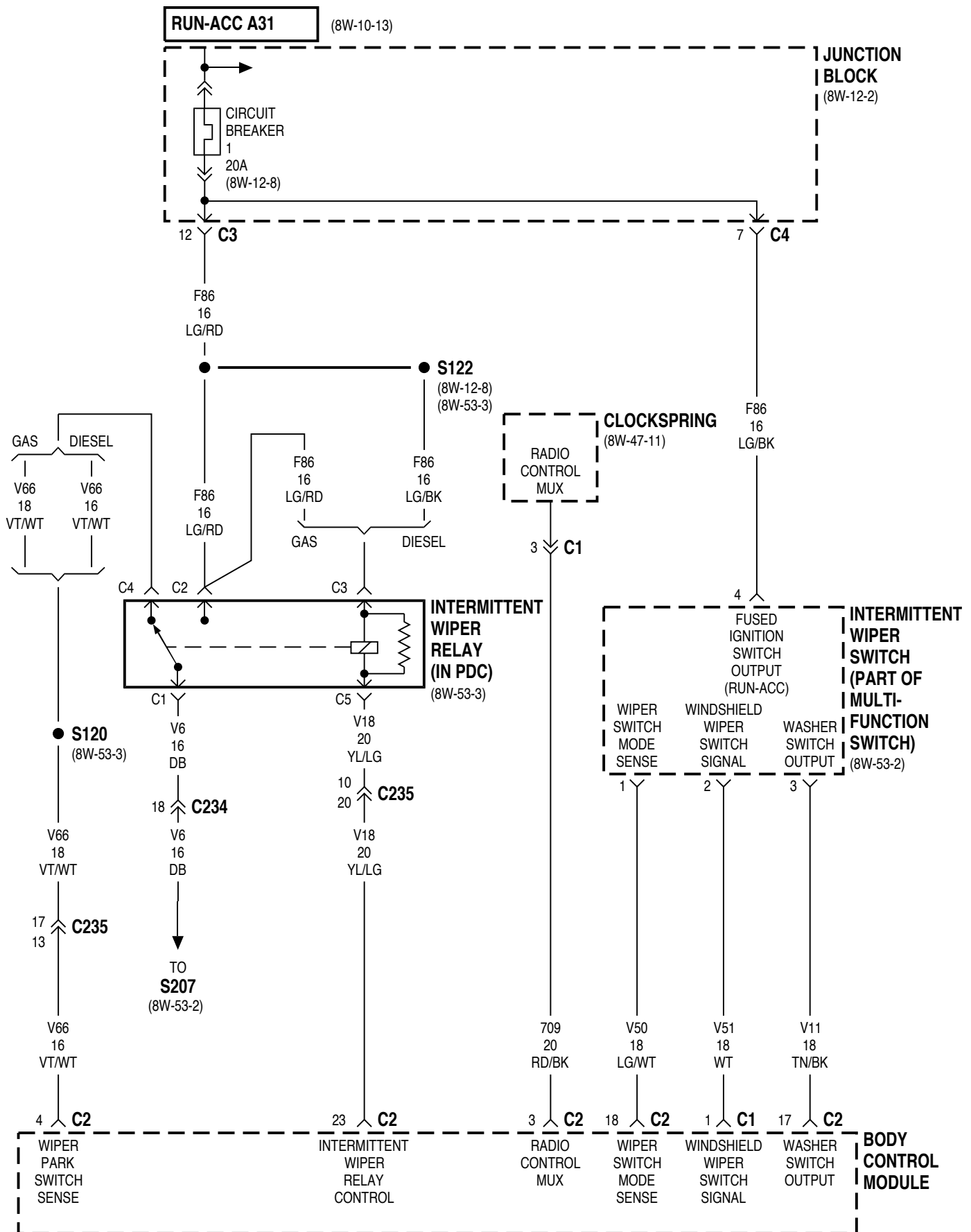


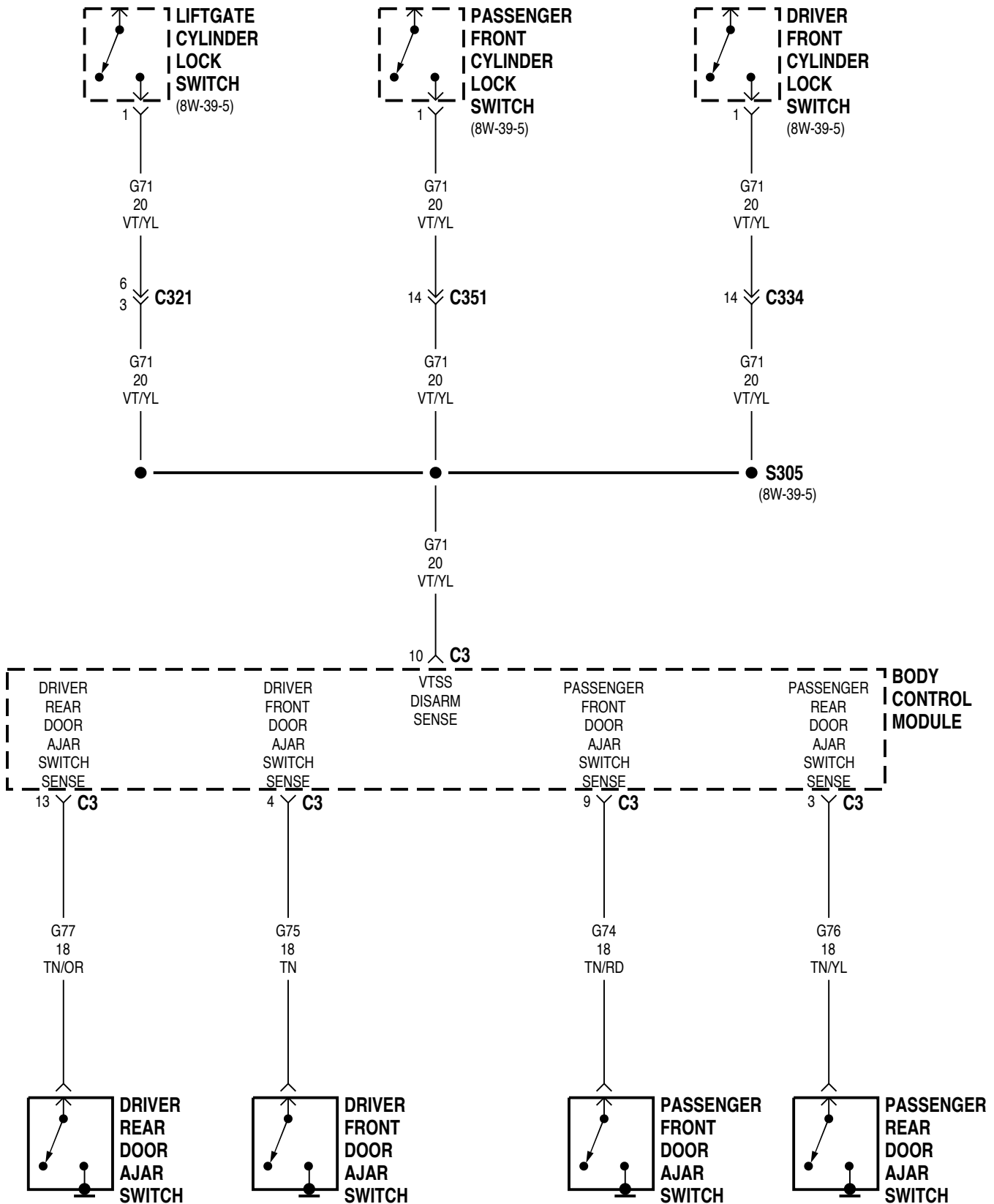


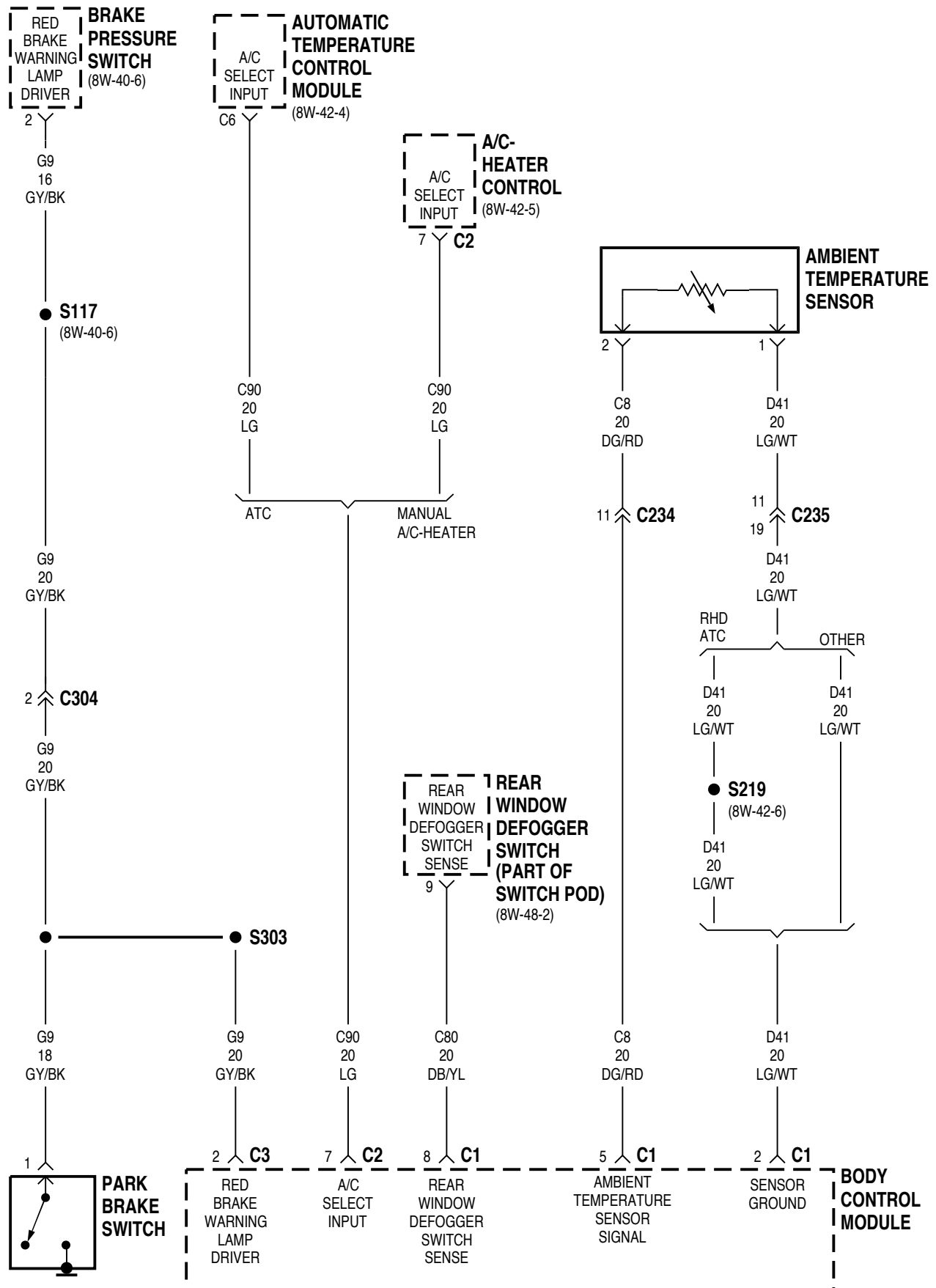


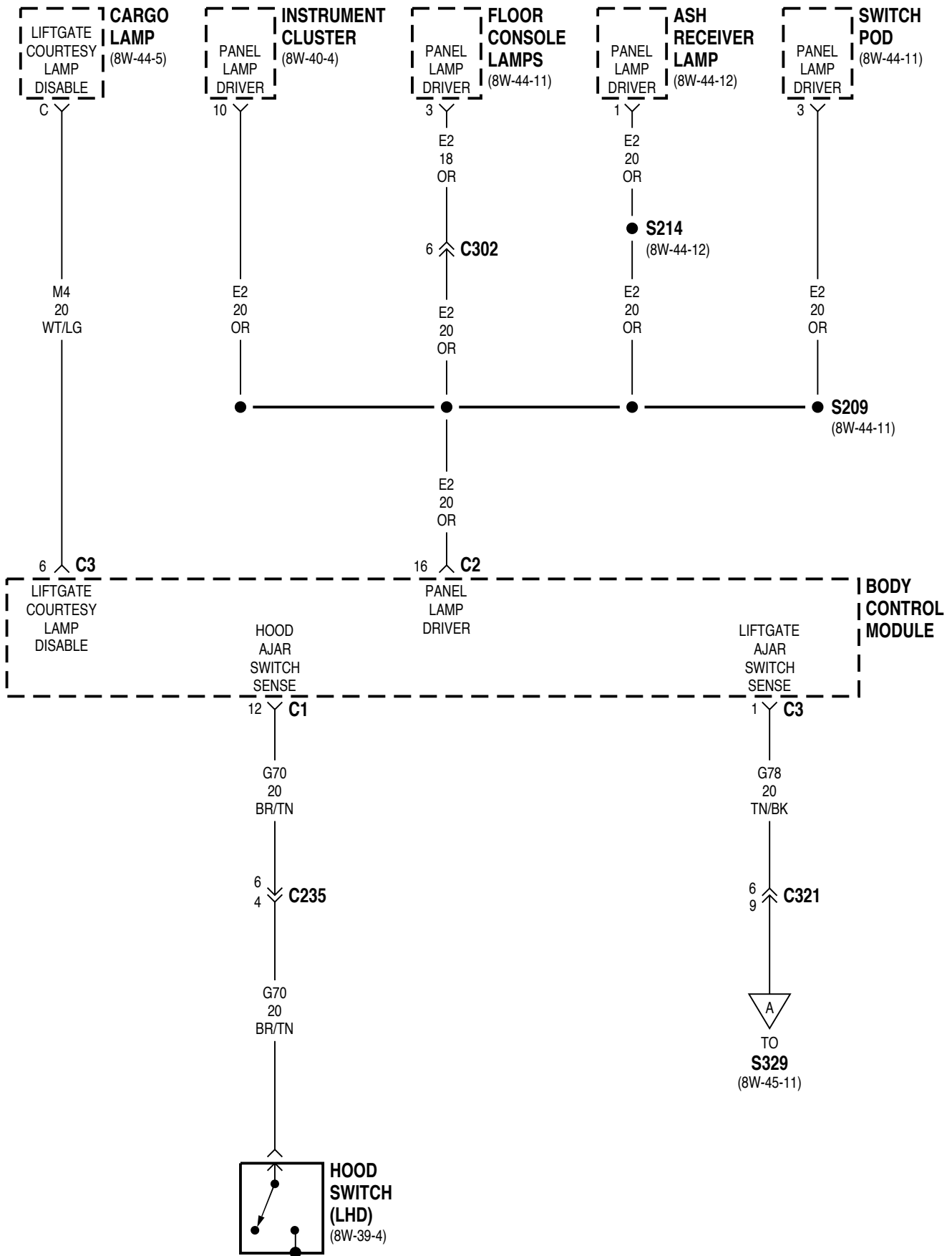


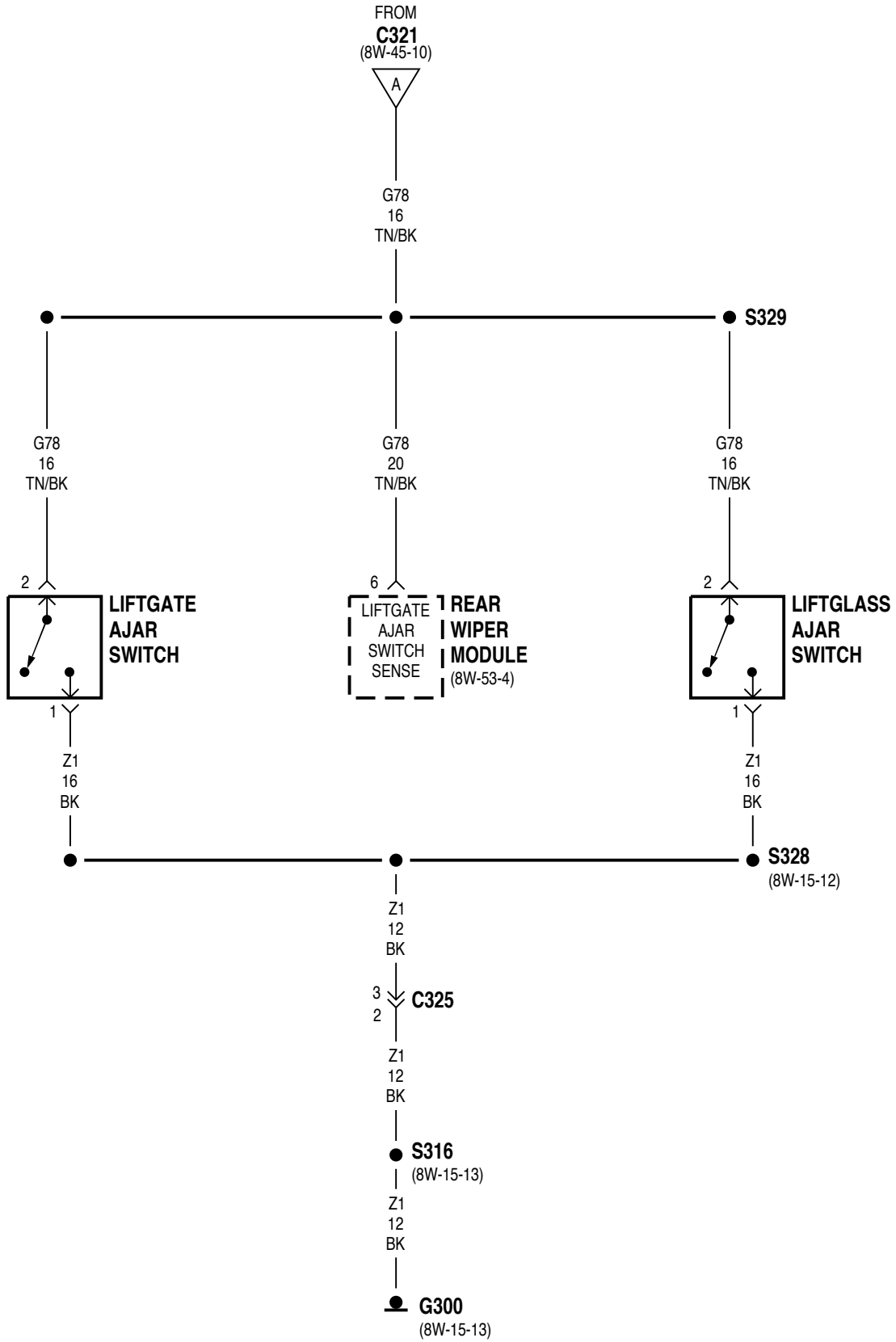






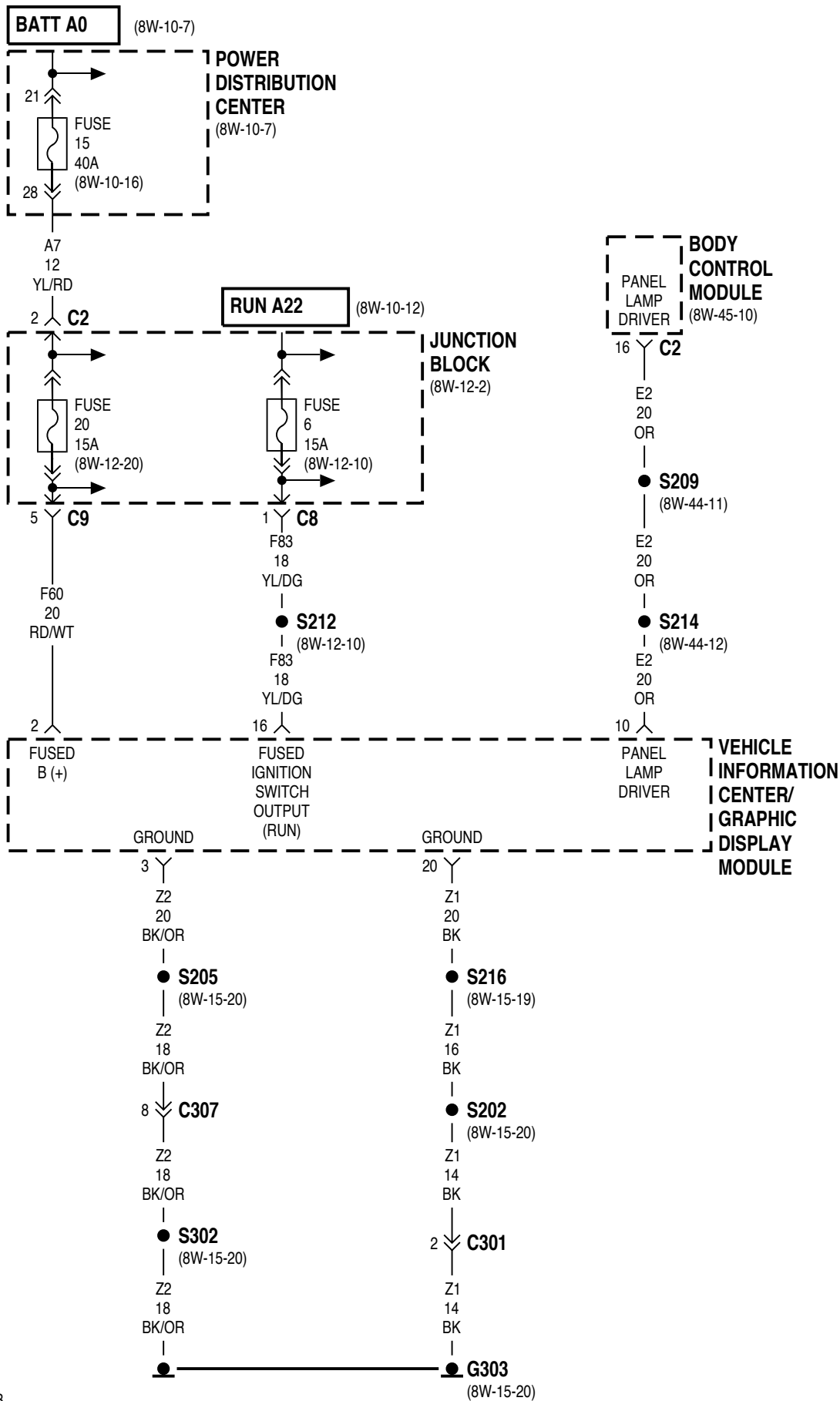


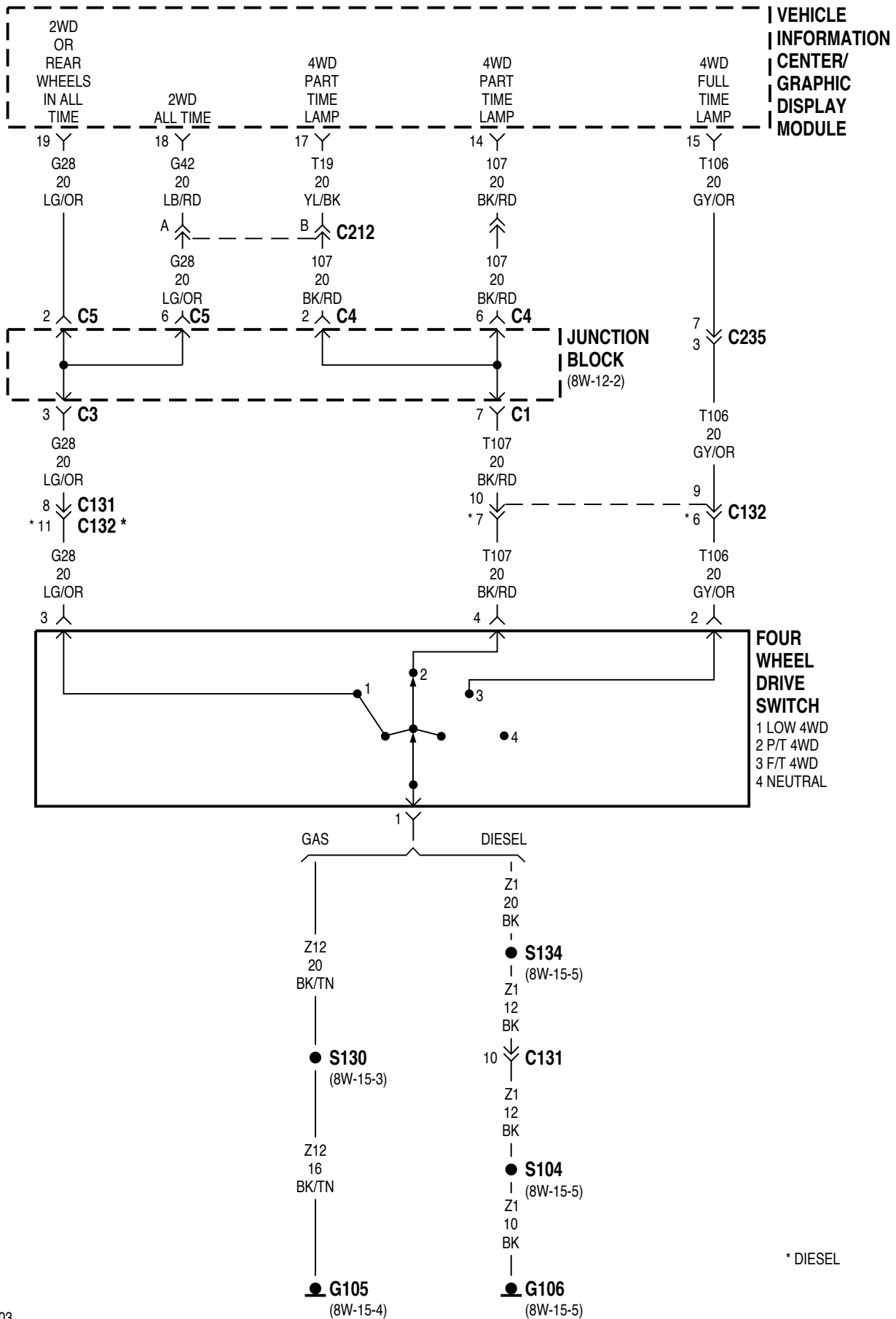


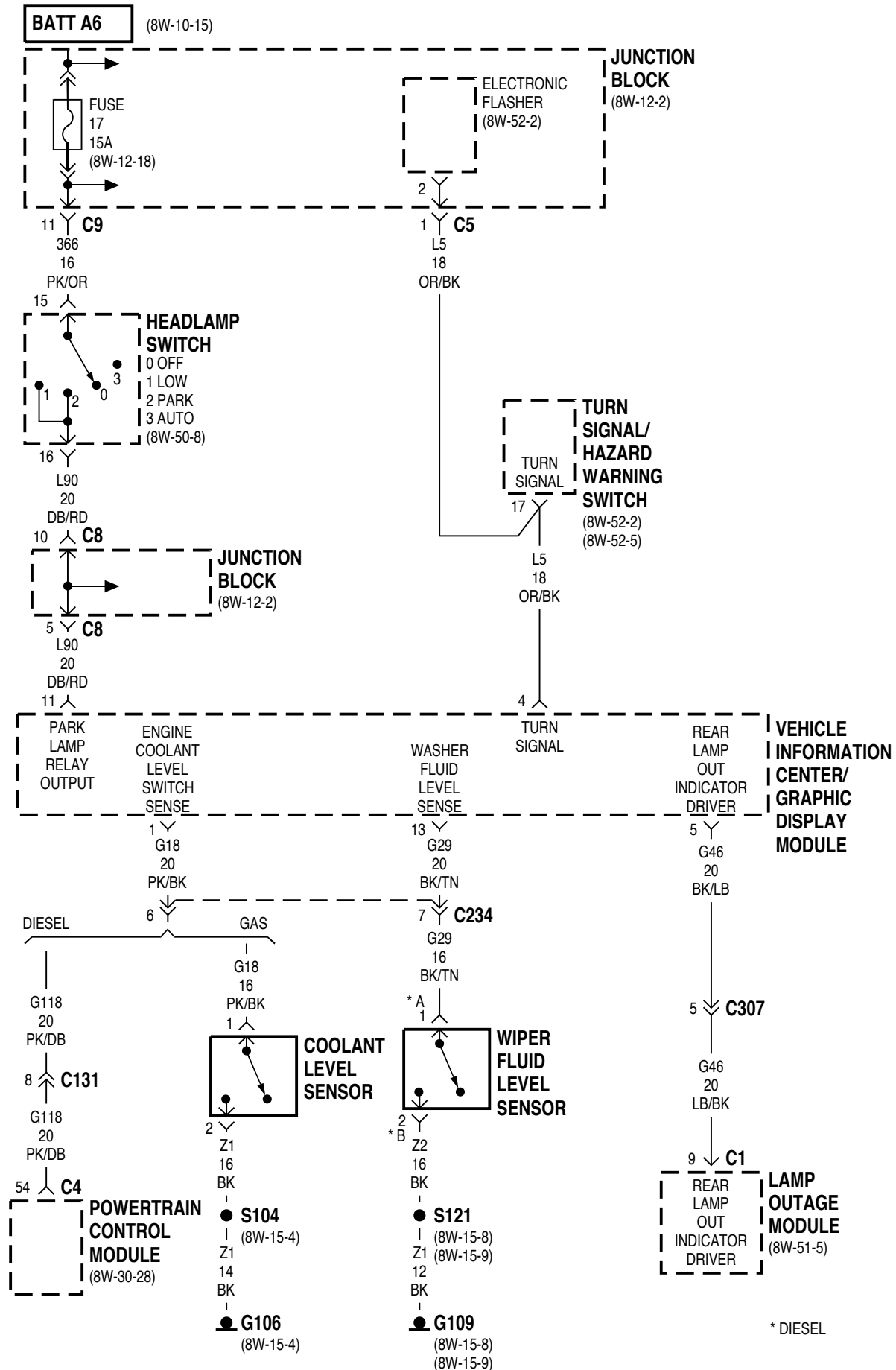


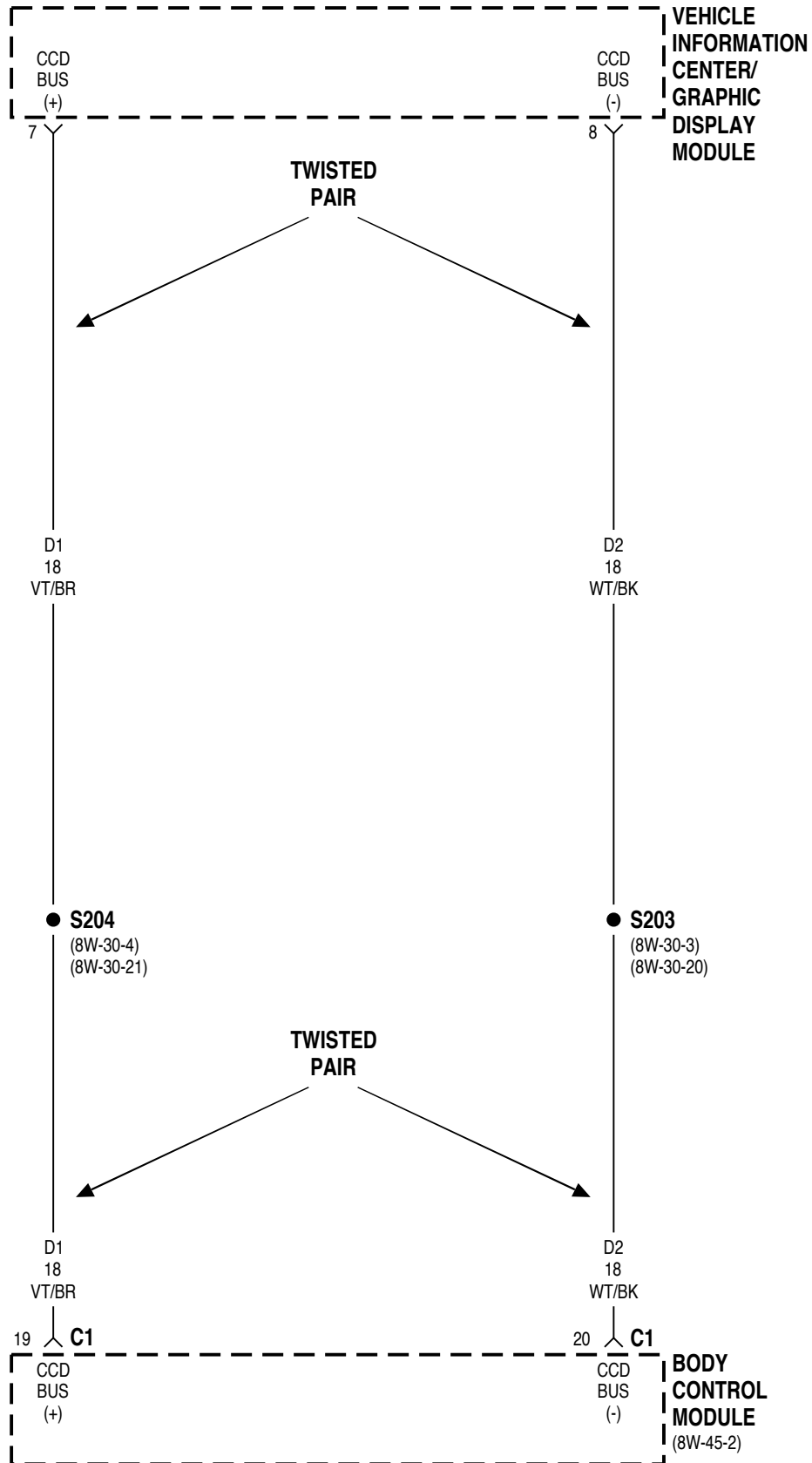
8W-46 MESSAGE CENTER

Component	Page	Component	Page
Body Control Module	8W-46-2, 5	G118	8W-46-4
Coolant Level Sensor	8W-46-4	G303	8W-46-2
Electronic Flasher	8W-46-4	Headlamp Switch	8W-46-4
Four Wheel Drive Switch	8W-46-3	Junction Block	8W-46-2, 3, 4
Fuse 6 (JB)	8W-46-2	Lamp Outage Module	8W-46-4
Fuse 15 (PDC)	8W-46-2	Power Distribution Center	8W-46-2
Fuse 17 (JB)	8W-46-4	Powertrain Control Module	8W-46-4
Fuse 20 (JB)	8W-46-2	Turn Signal/Hazard Warning Switch	8W-46-4
G105	8W-46-3	Vehicle Information Center/ Graphic Display Module	8W-46-2, 3, 4, 5
G106	8W-46-3, 4	Wiper Fluid Level Sensor	8W-46-4
G109	8W-46-4		



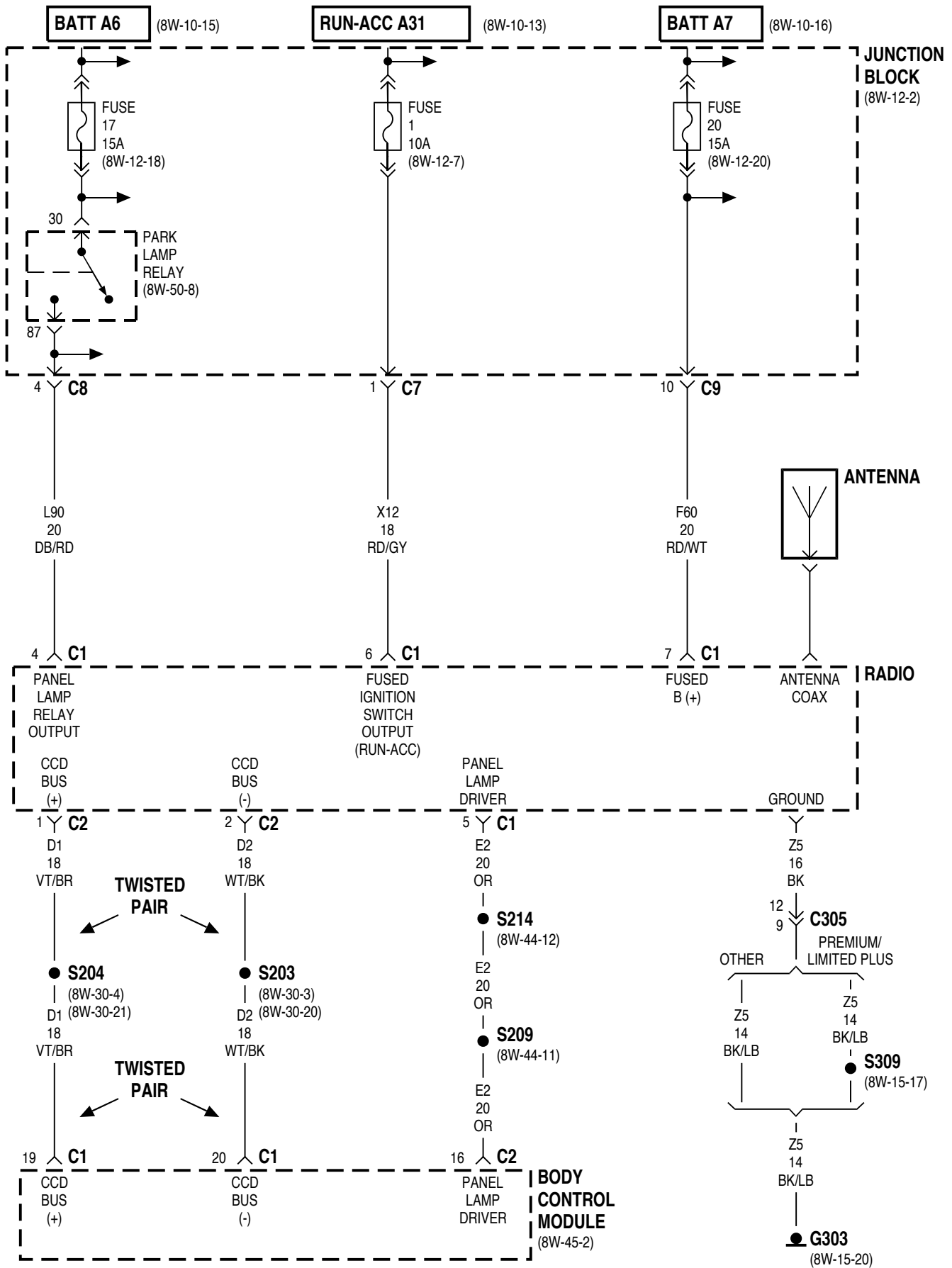


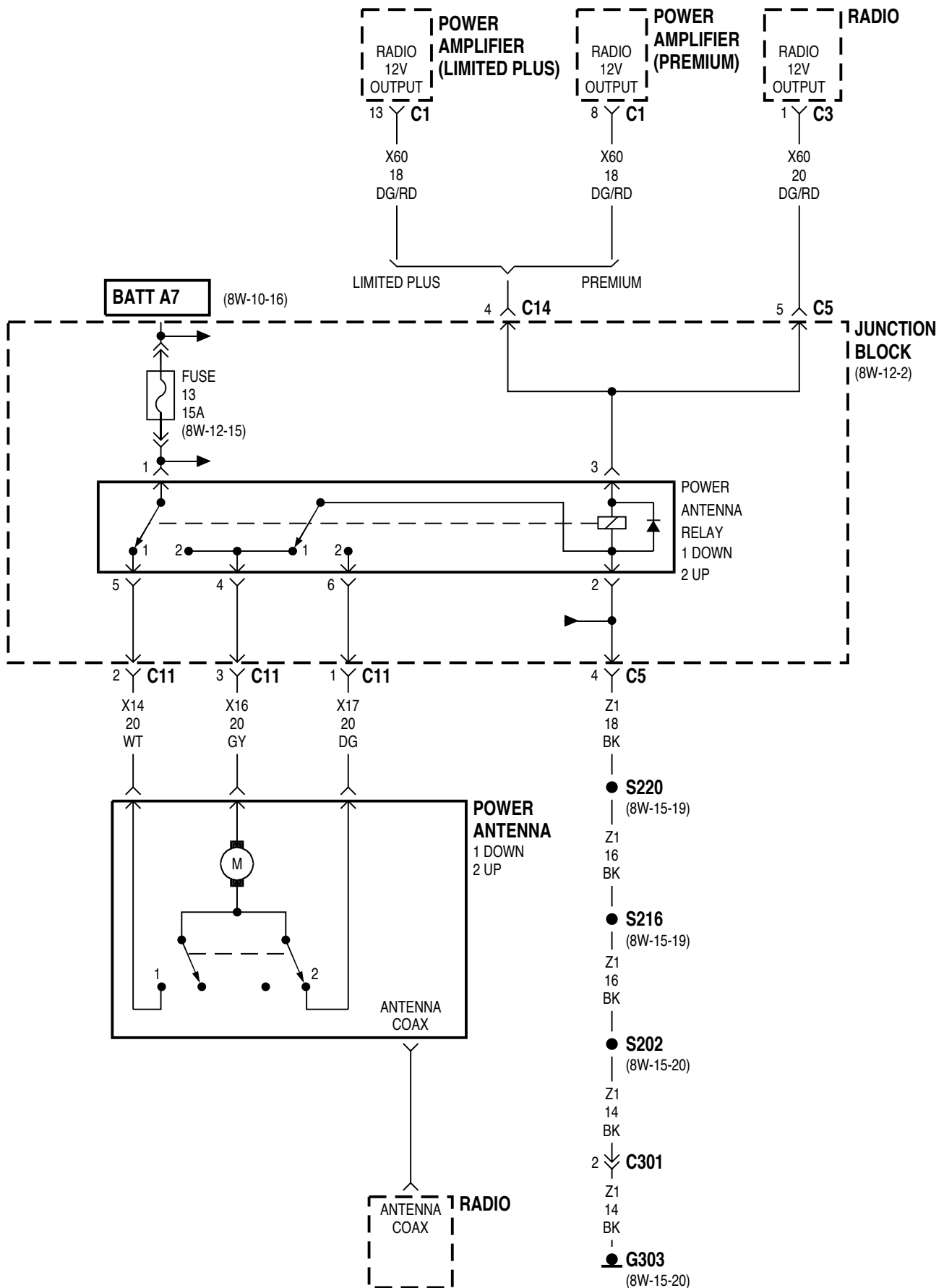


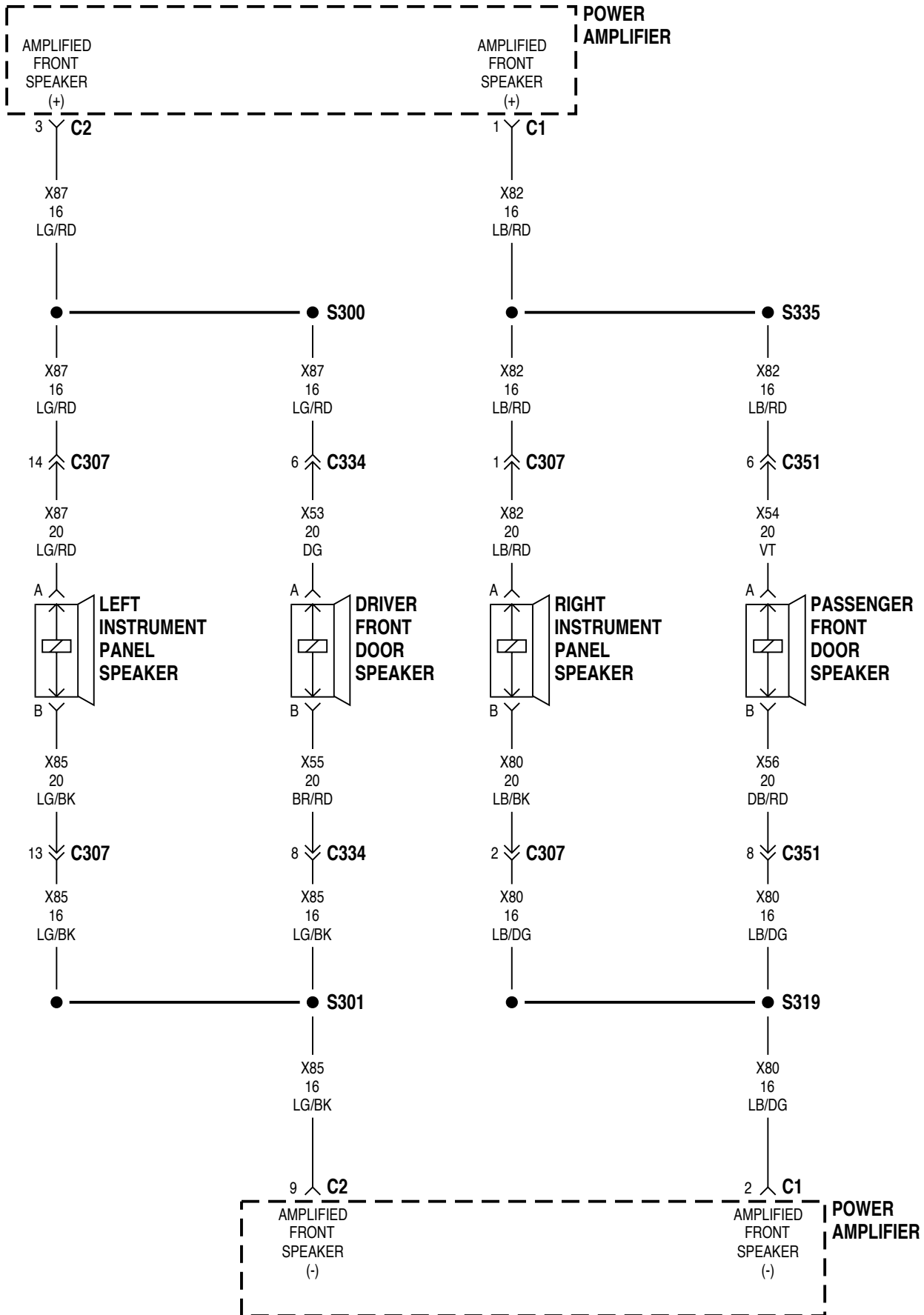


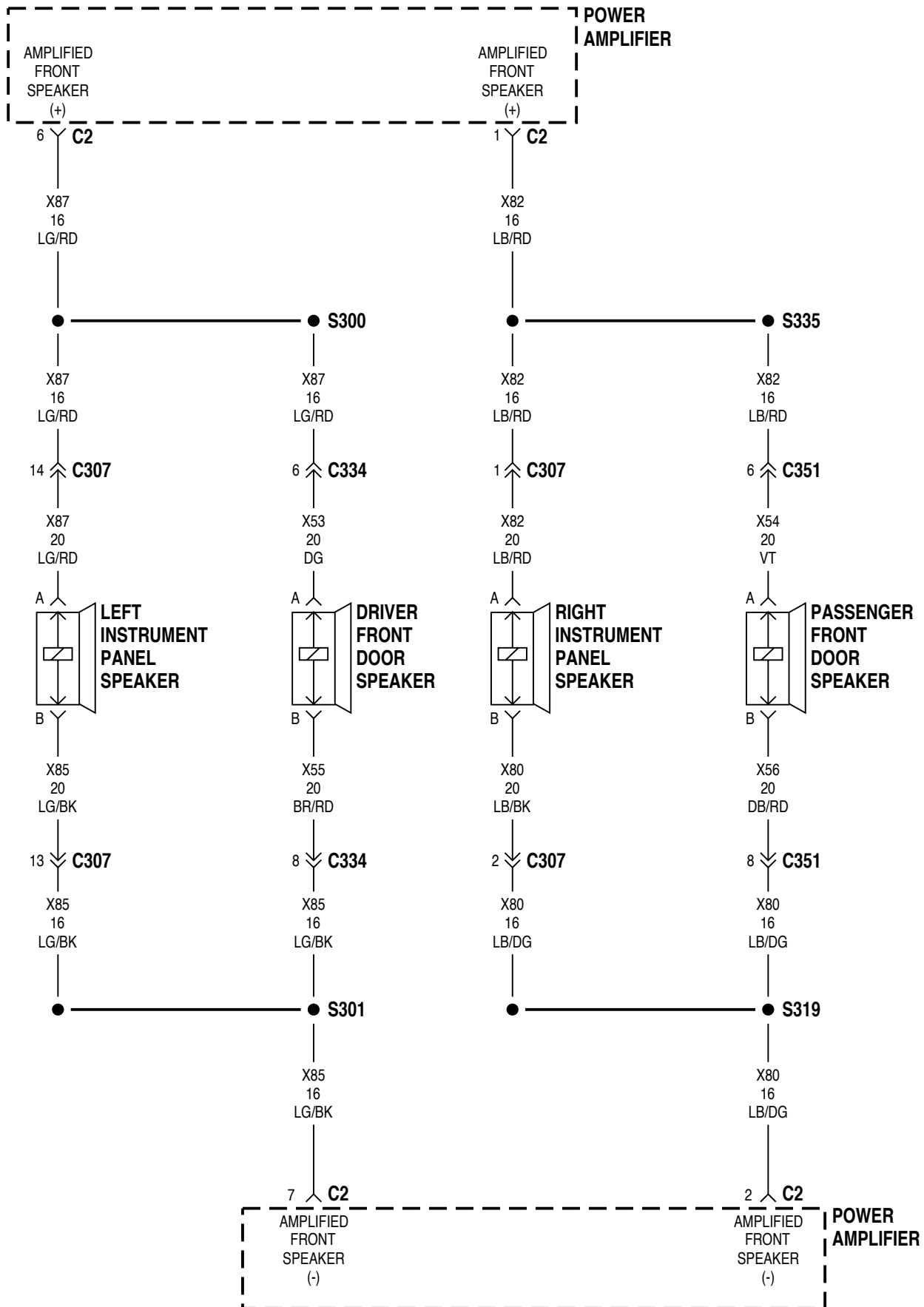
8W-47 AUDIO SYSTEM

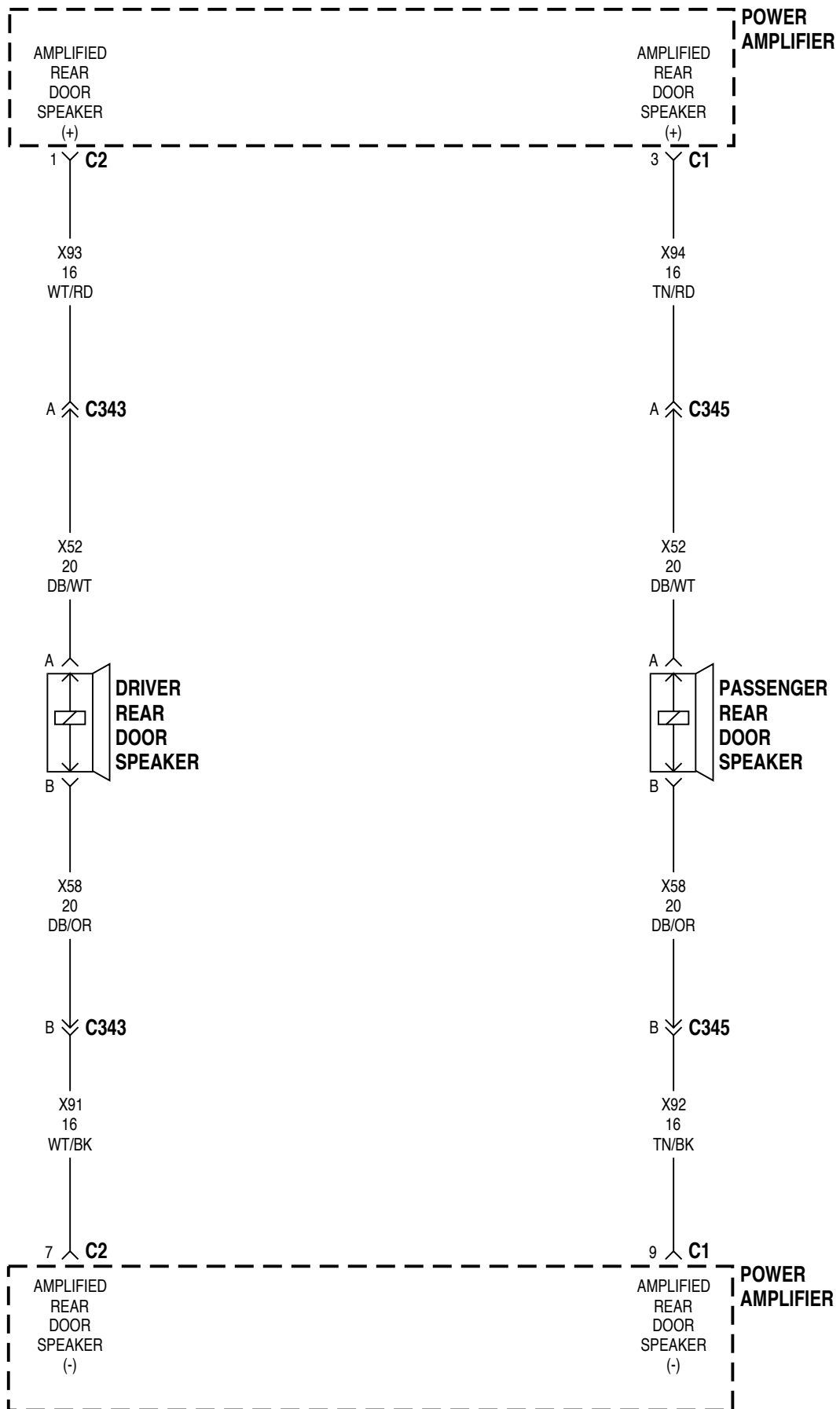
Component	Page	Component	Page
Antenna8W-47-2	Left Instrument Panel Speaker8W-47-4, 5
Body Control Module8W-47-2, 11	Park Lamp Relay8W-47-2
Clockspring8W-47-11	Passenger Front Door Speaker8W-47-4, 5, 7
Driver Front Door Speaker8W-47-4, 5, 7	Passenger Rear Door Speaker8W-47-6, 7, 10
Driver Rear Door Speaker8W-47-6, 7, 10	Power Amplifier8W-47-3, 4, 5, 6, 7, 8, 9, 10
Fuse 1 (JB)8W-47-2	Power Antenna8W-47-3
Fuse 7 (JB)8W-47-8, 9	Power Antenna Relay8W-47-3
Fuse 13 (JB)8W-47-3	Radio8W-47-2, 3, 7, 8, 9
Fuse 17 (JB)8W-47-2	Rear Speaker8W-47-10
Fuse 20 (JB)8W-47-2	Remote Radio Switch No. 18W-47-11
G3038W-47-2, 3, 8, 9, 11	Remote Radio Switch No. 28W-47-11
Junction Block8W-47-2, 3, 8, 9	Right Instrument Panel Speaker8W-47-4, 5

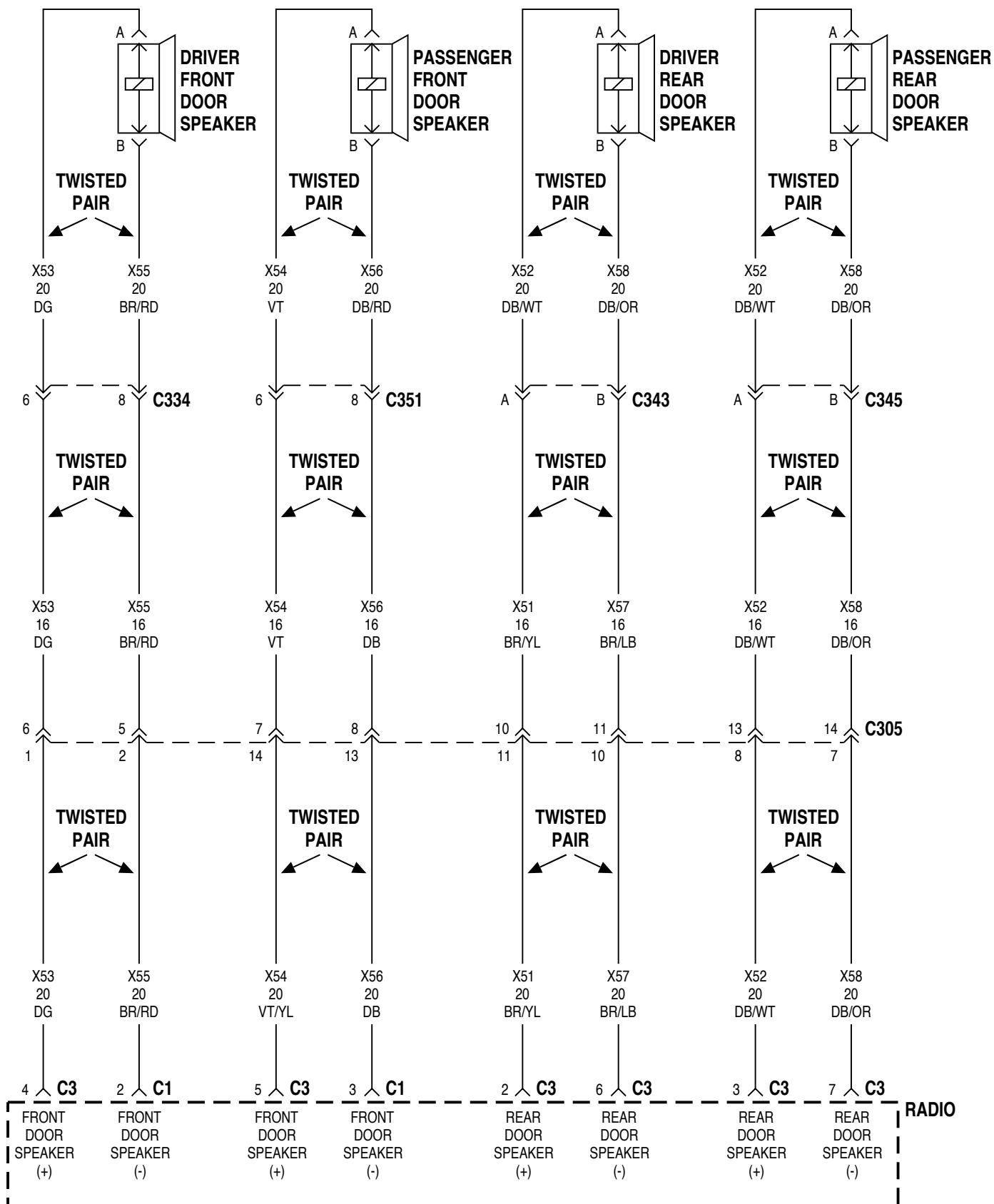


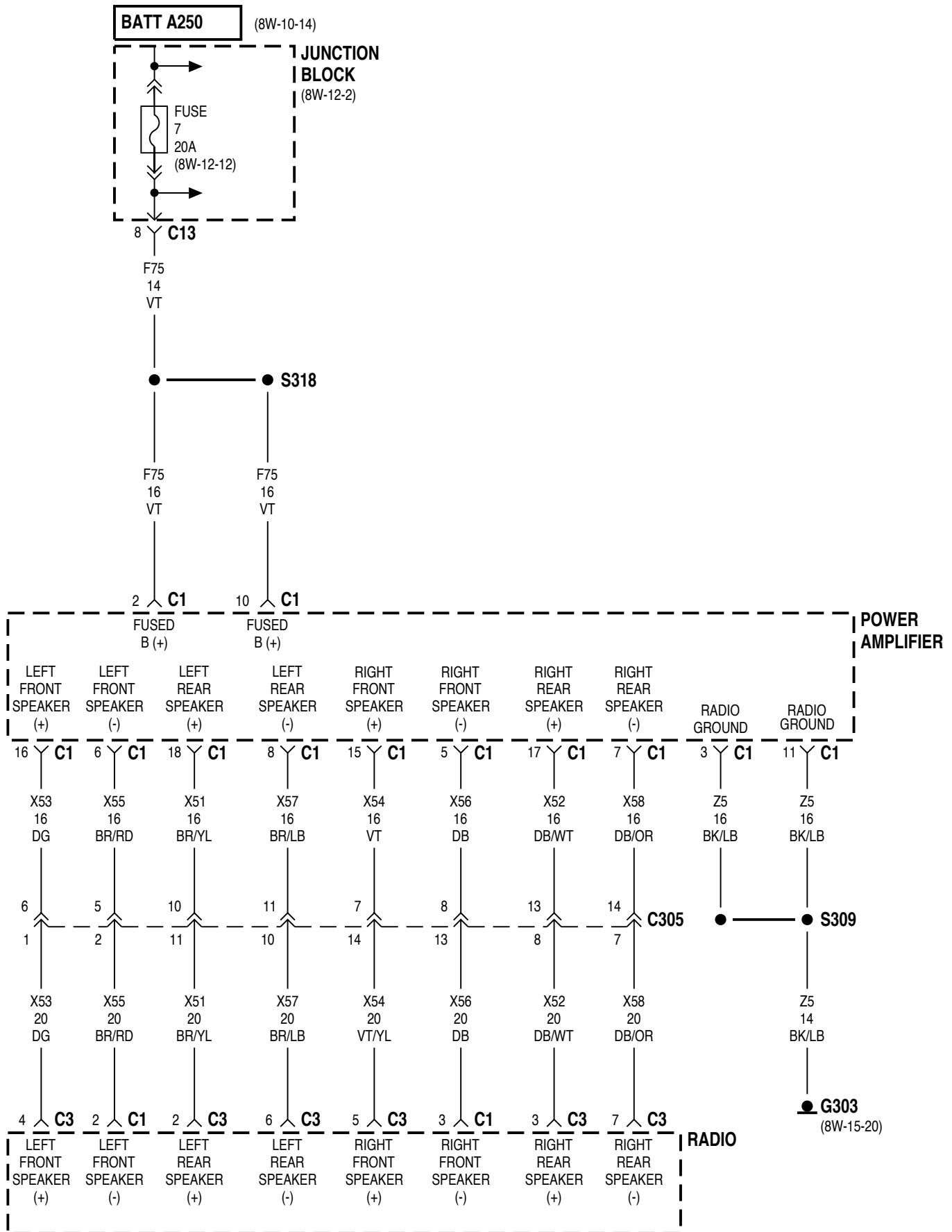


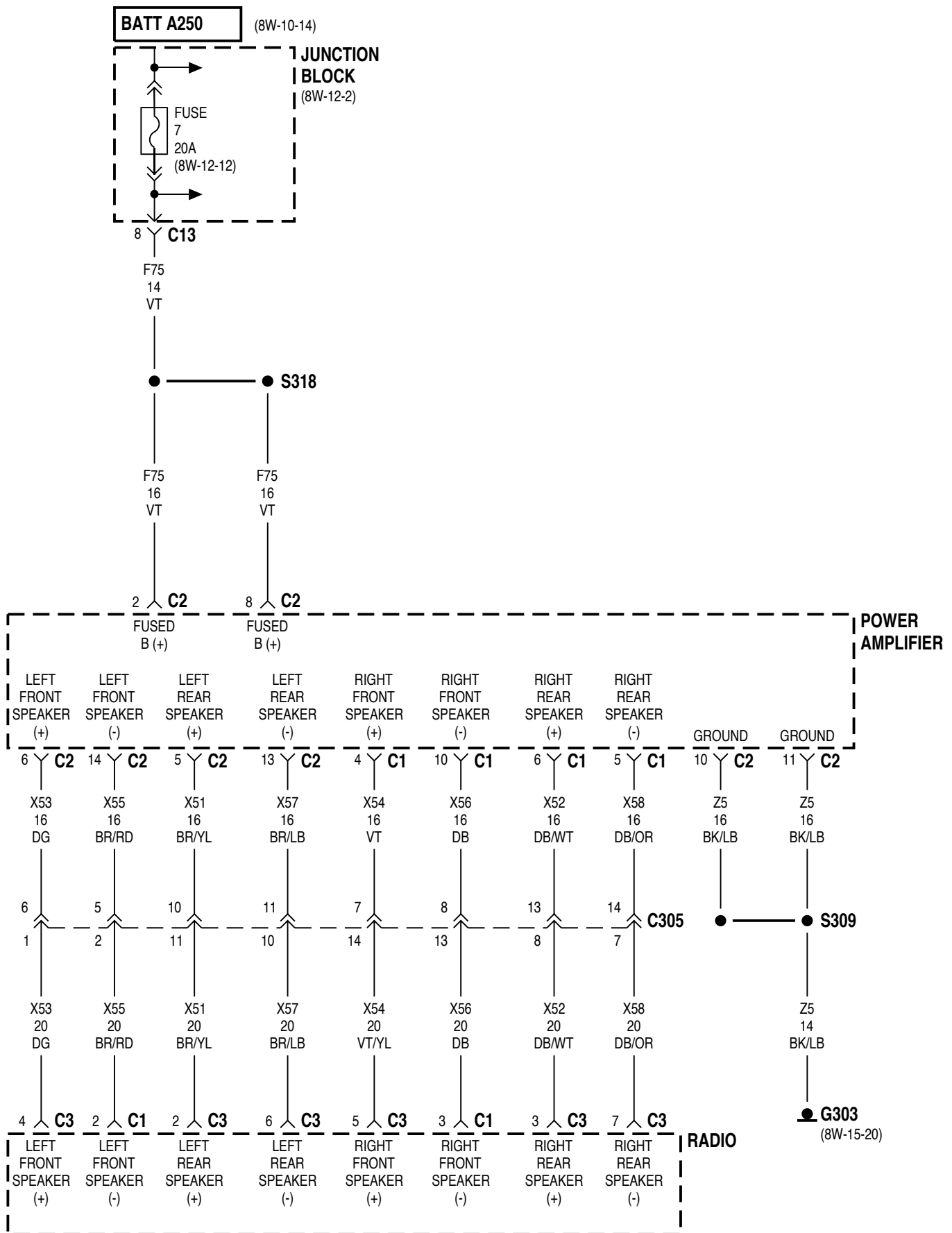


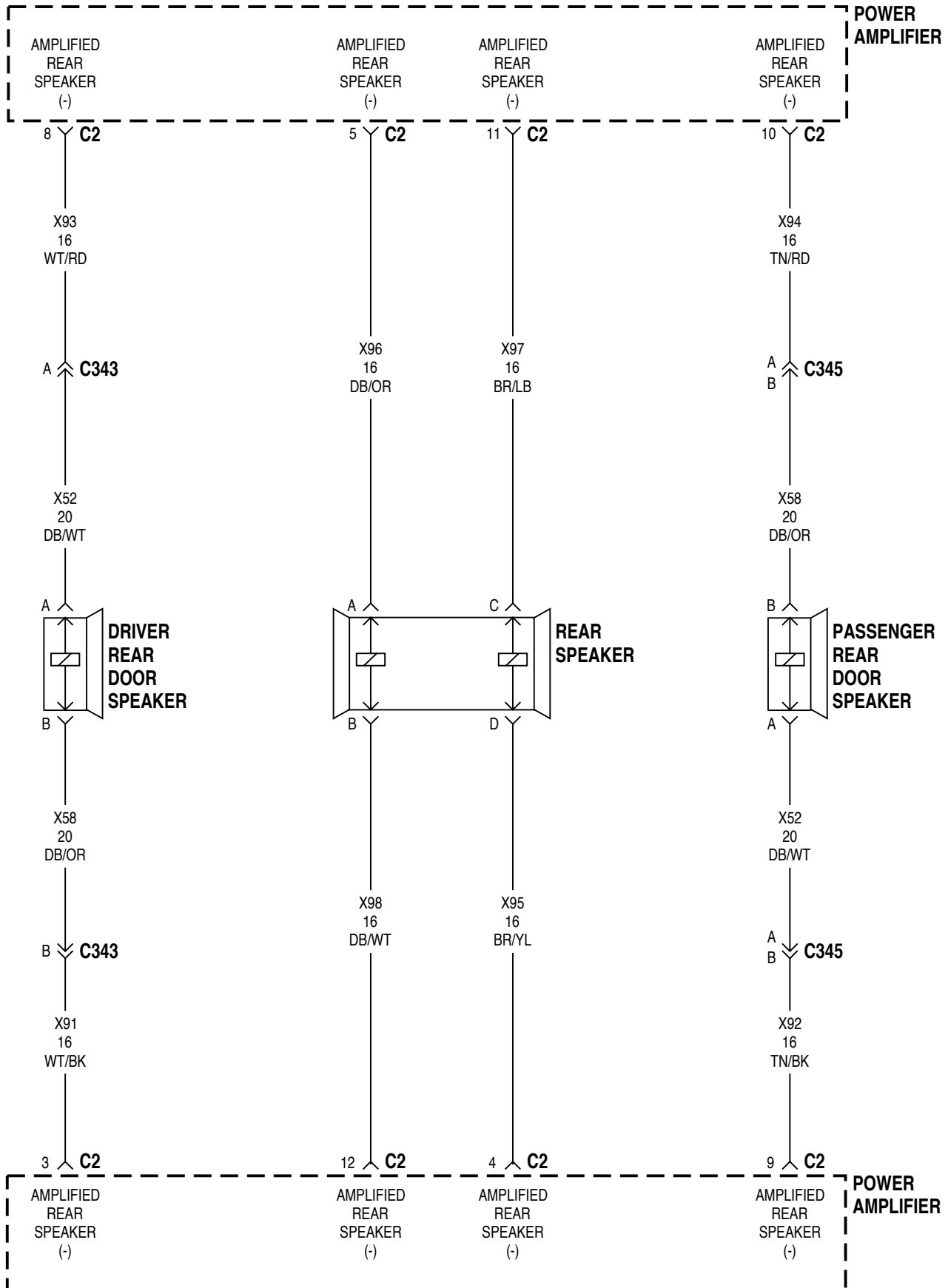


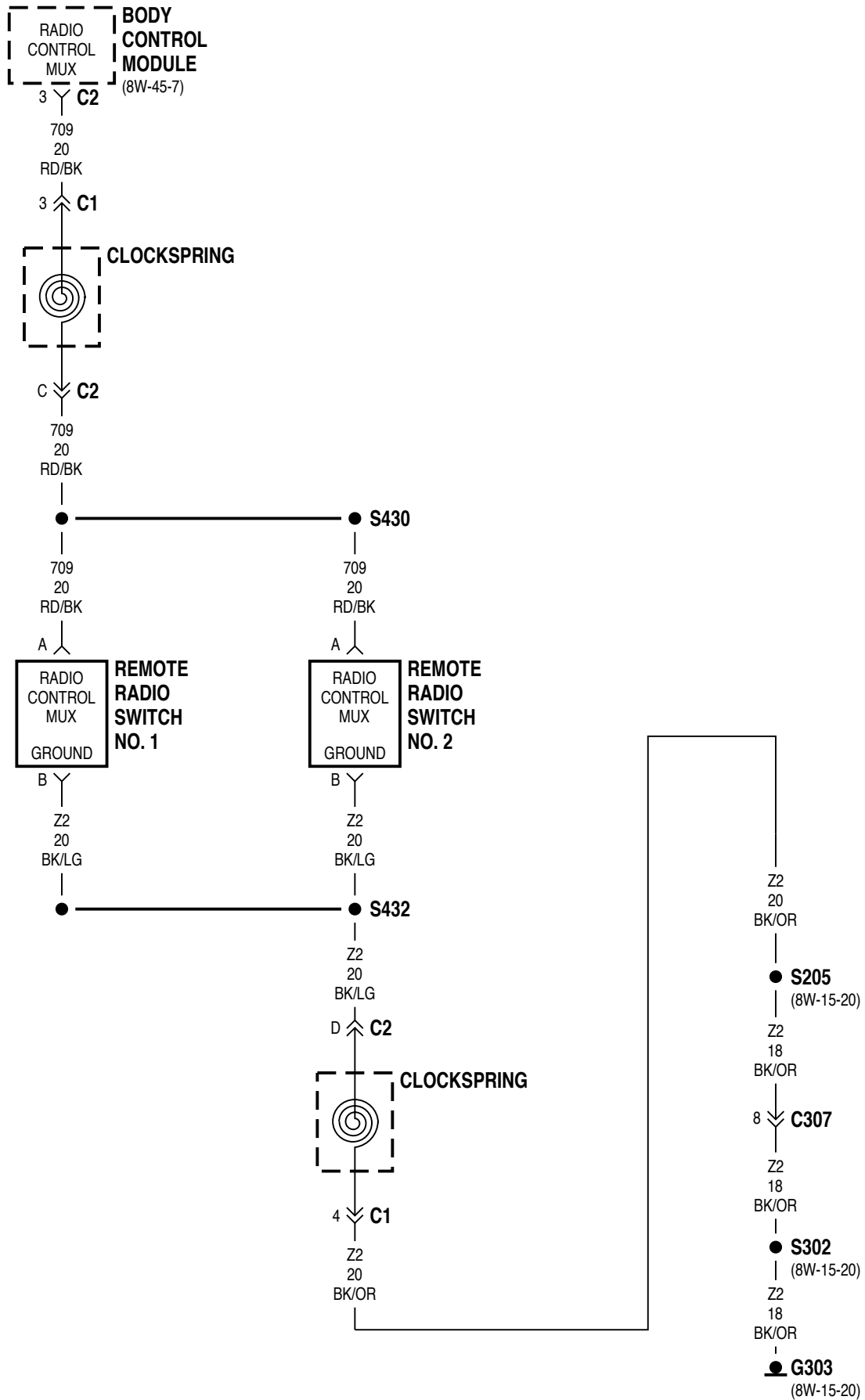






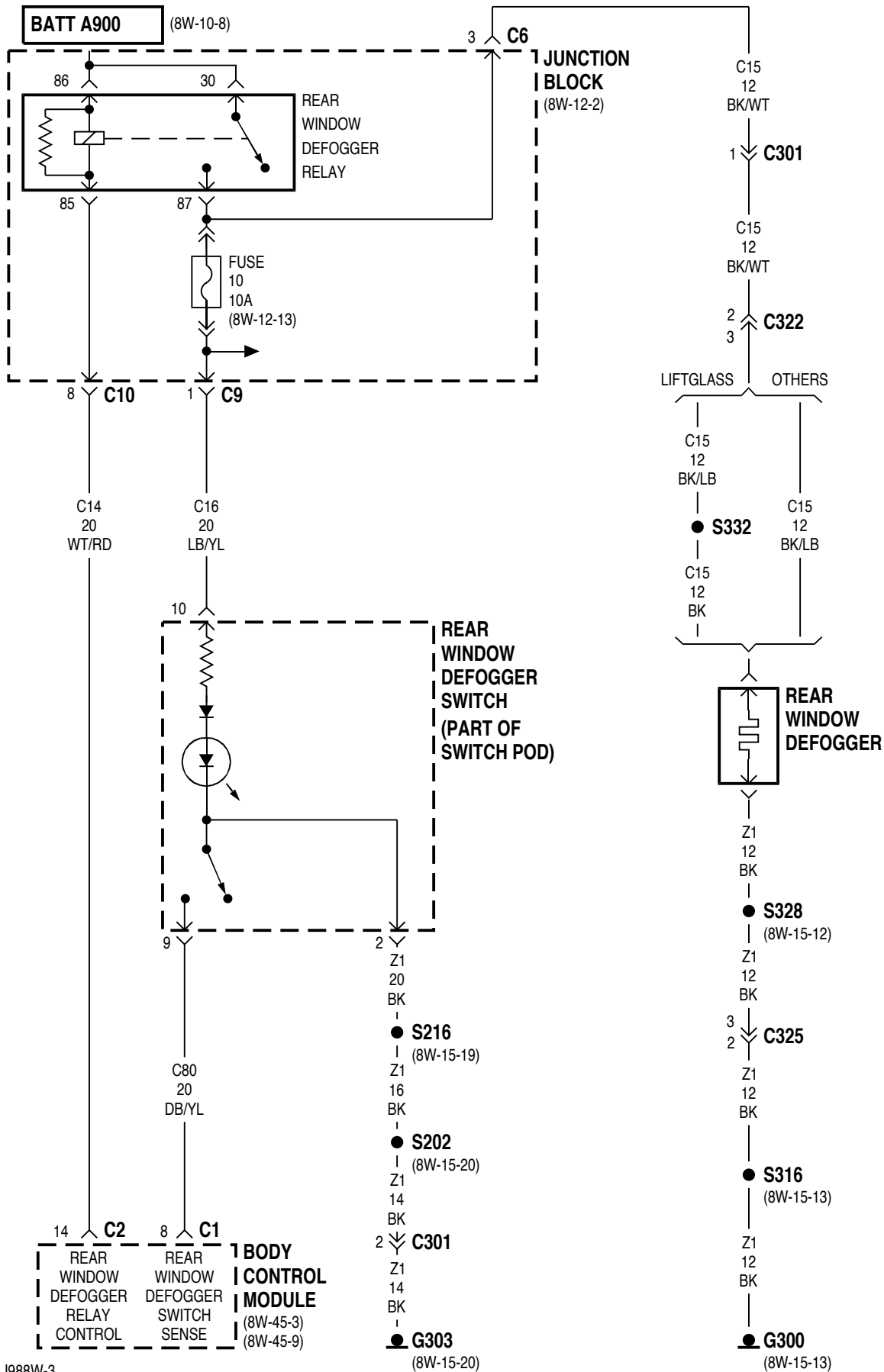






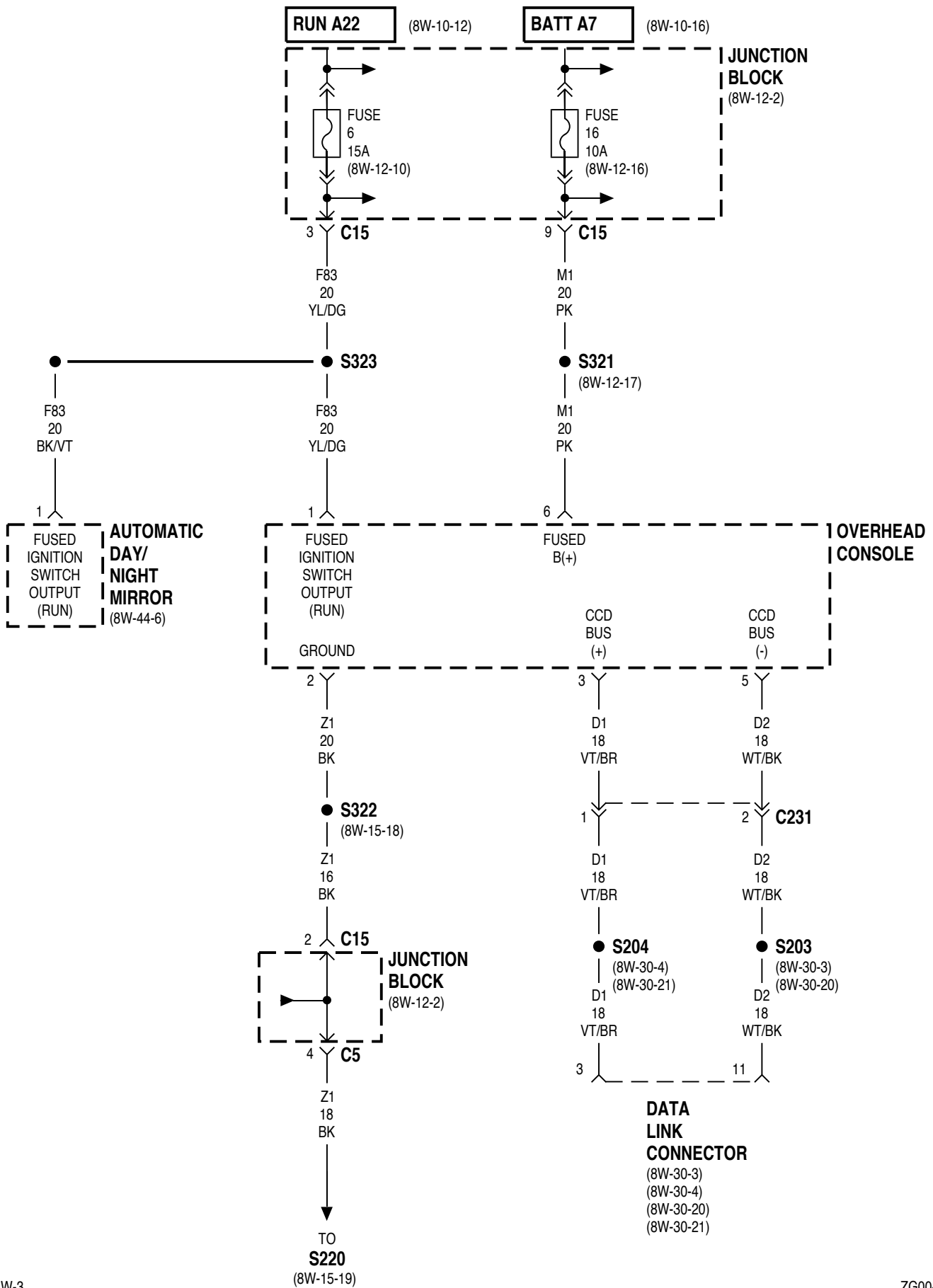
8W-48 REAR WINDOW DEFOGGER

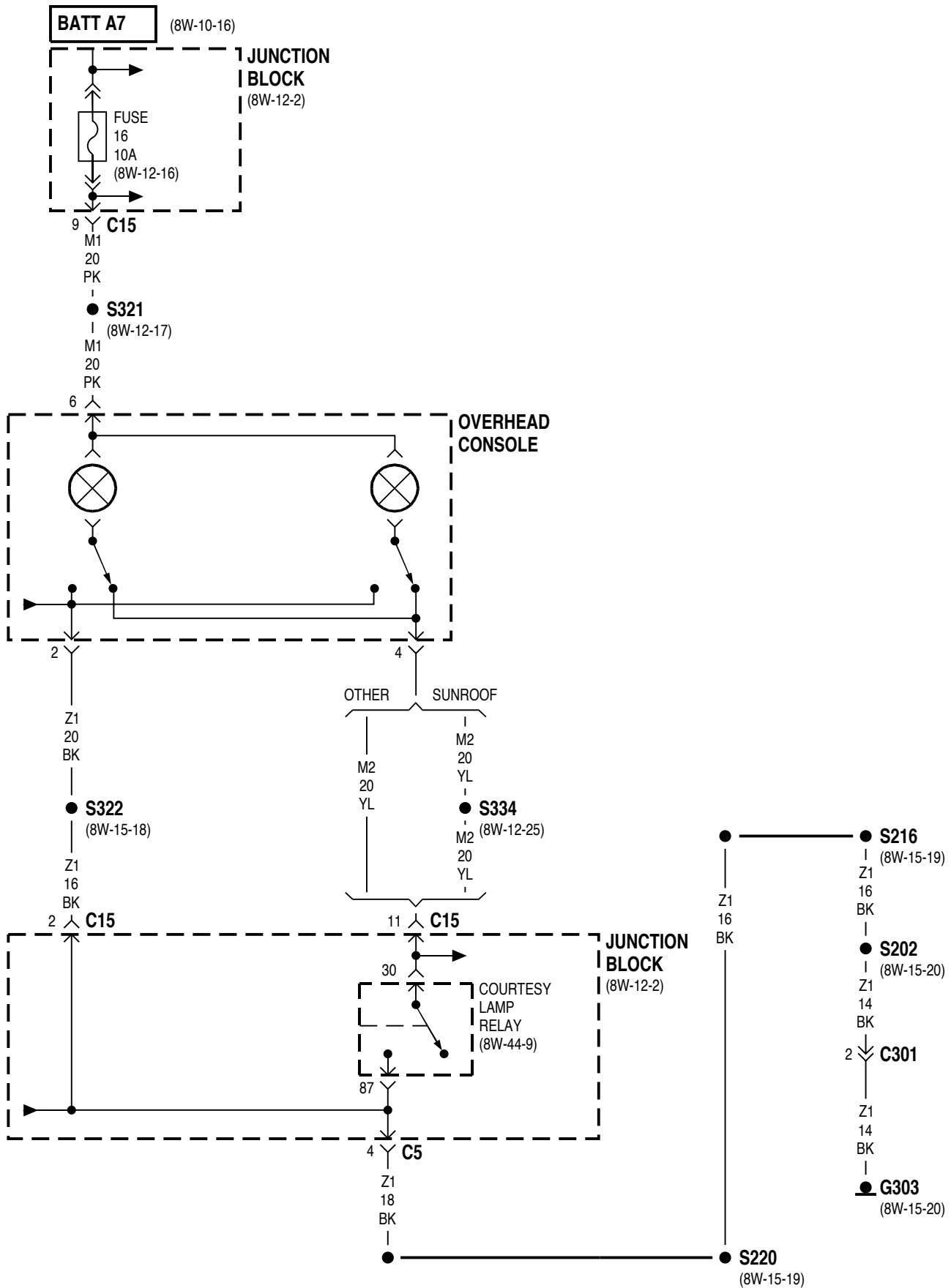
Component	Page	Component	Page
Body Control Module8W-48-2	Junction Block8W-48-2
Fuse 10 (JB)8W-48-2	Rear Window Defogger8W-48-2
G3008W-48-2	Rear Window Defogger Relay8W-48-2
G3038W-48-2	Rear Window Defogger Switch8W-48-2



8W-49 OVERHEAD CONSOLE

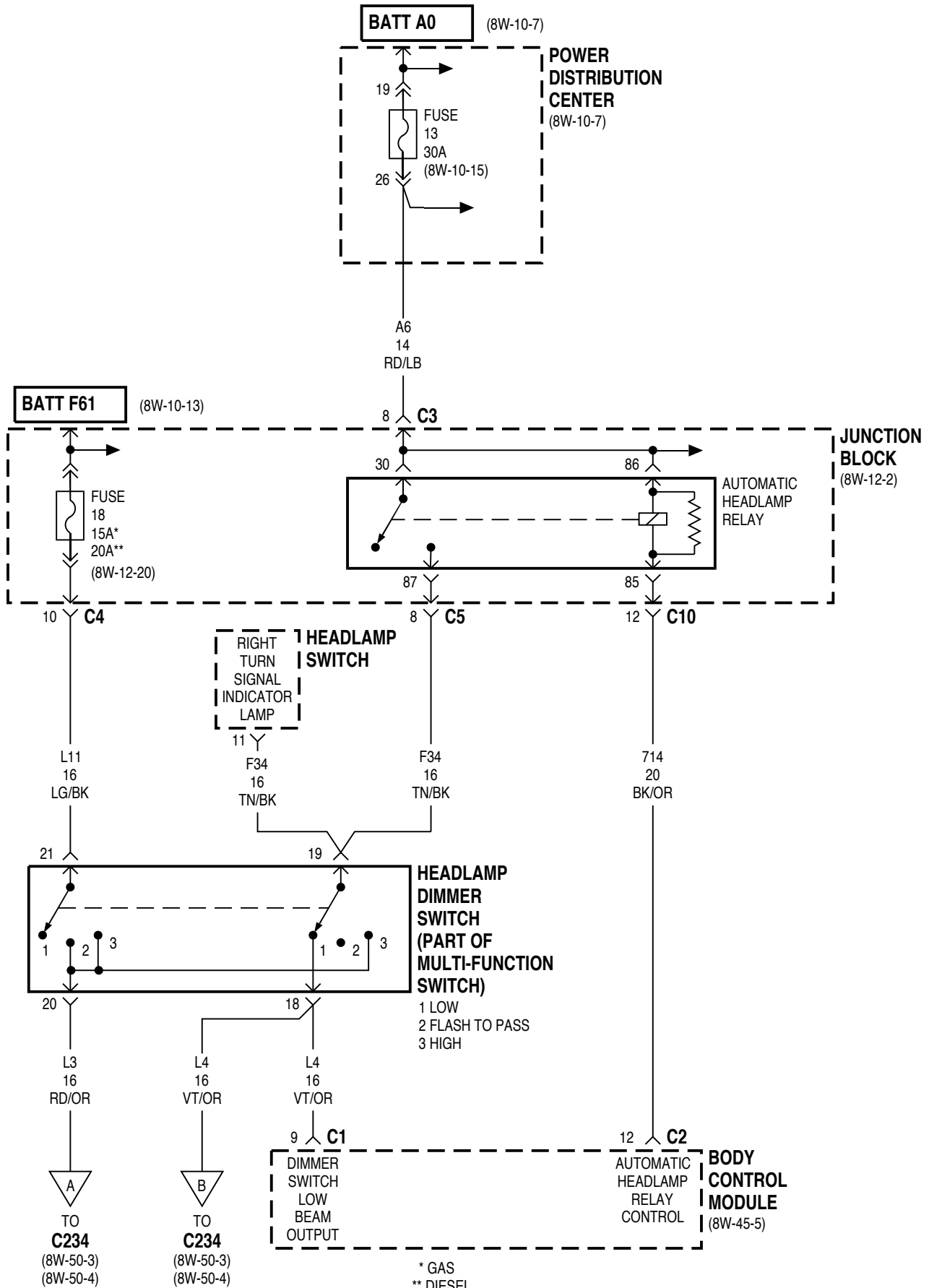
Component	Page	Component	Page
Automatic Day/Night Mirror	8W-49-2	Fuse 16 (JB)	8W-49-2, 3
Courtesy Lamp Relay	8W-49-3	G303	8W-49-3
Data Link Connector	8W-49-2	Junction Block	8W-49-2, 3
Fuse 6 (JB)	8W-49-2	Overhead Console	8W-49-2, 3

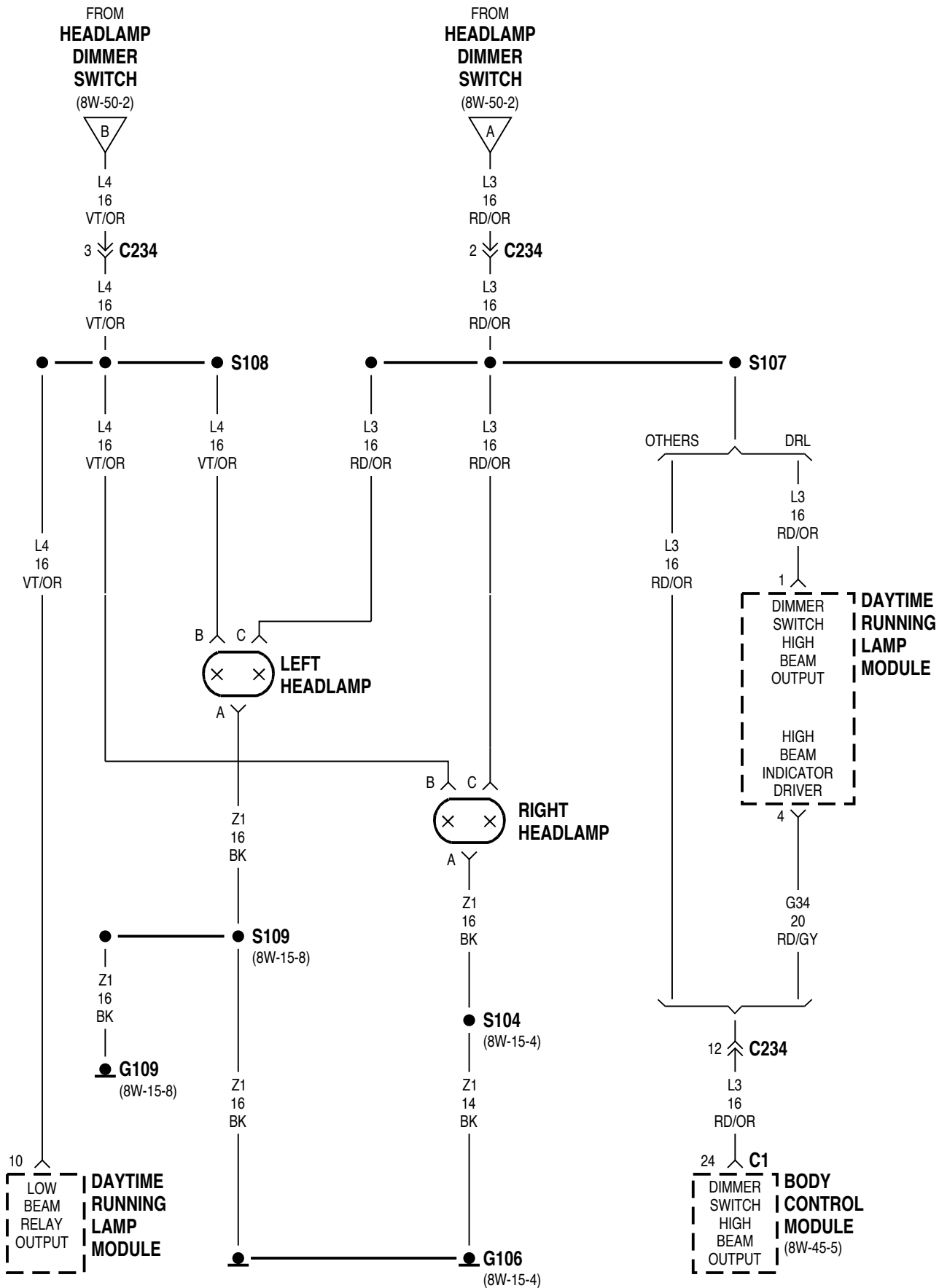


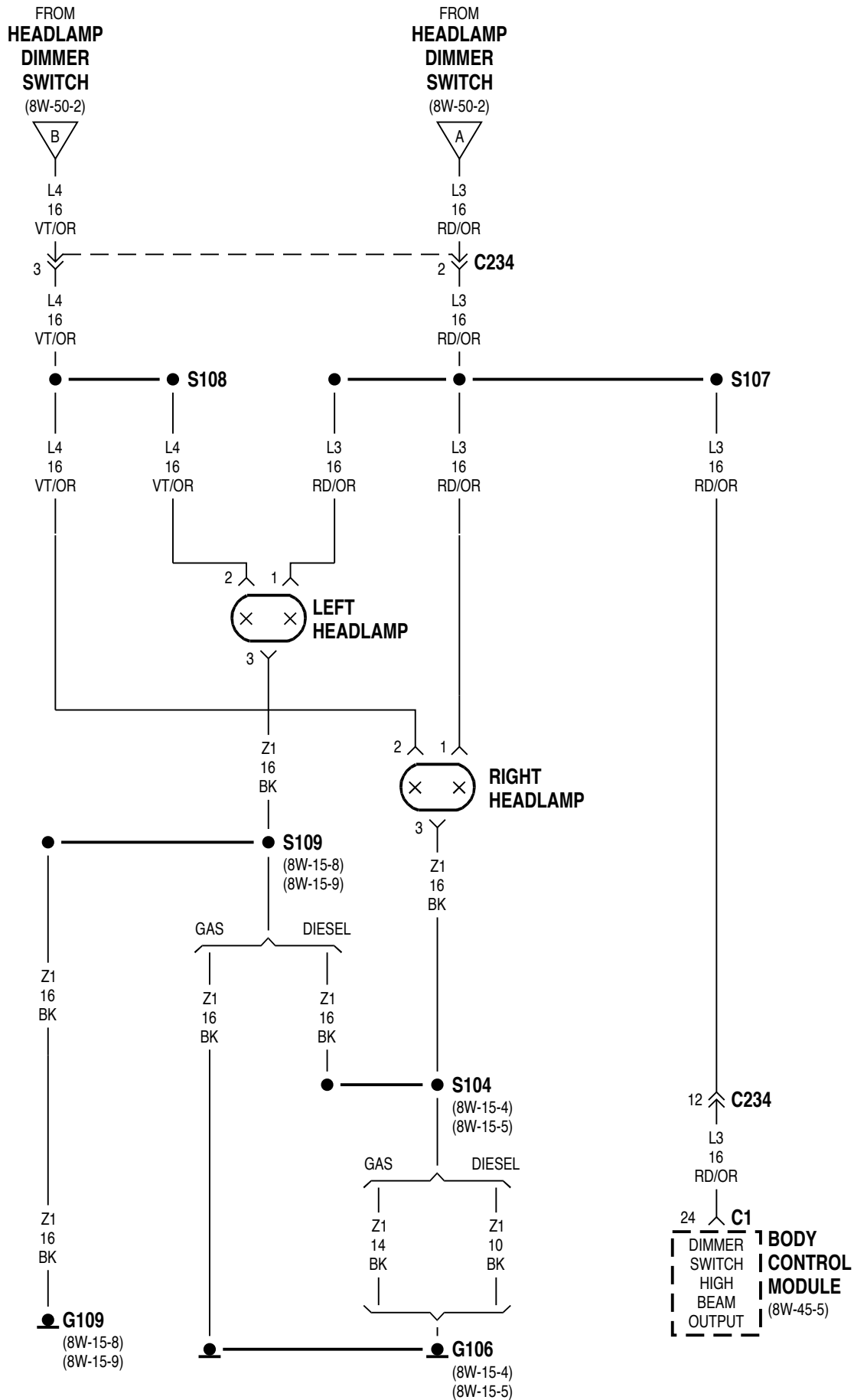


8W-50 FRONT LIGHTING

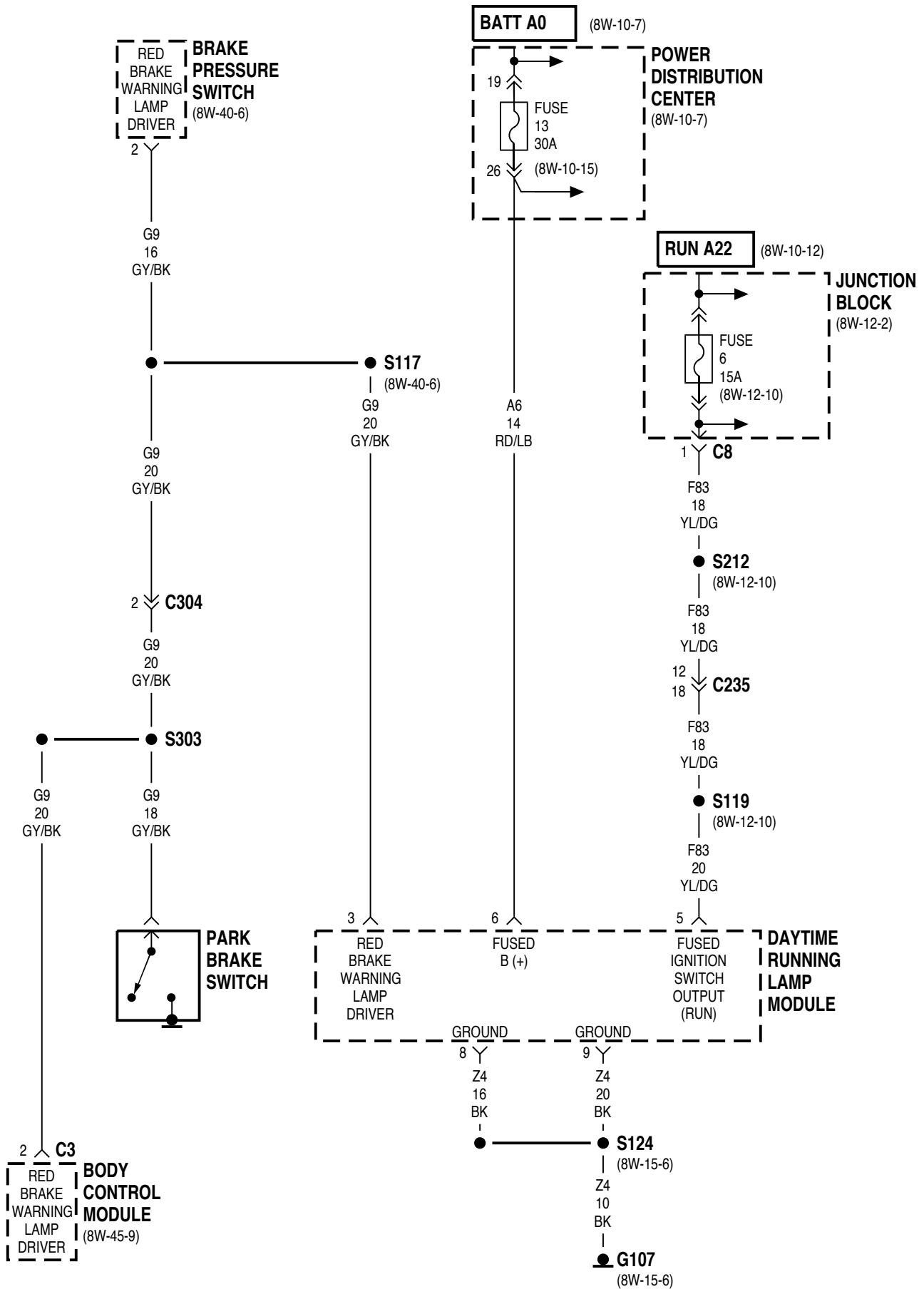
Component	Page	Component	Page
Automatic Headlamp Light Sensor/ Vtss Led8W-50-6	Instrument Cluster8W-50-10, 11
Automatic Headlamp Relay8W-50-2	Junction Block8W-50-2, 5, 7, 8, 9, 11, 12
Body Control Module8W-50-2, 3, 4, 5, 6, 7, 8, 9	Left Fog Lamp8W-50-7
Brake Pressure Switch8W-50-5	Left Front Park Lamp.8W-50-10
Circuit Breaker8W-50-6	Left Front Side Marker Lamp.8W-50-10
Daytime Running Lamp Module8W-50-3, 5	Left Front Turn Signal Lamp8W-50-10
Fog Lamp Relay8W-50-7	Left Headlamp8W-50-3, 4
Fog Lamp Switch8W-50-8	Left Headlamp Leveling Motor8W-50-12
Fuse 6 (JB)8W-50-5, 12	Left Side Repeater8W-50-10
Fuse 13 (PDC).8W-50-2, 5	Park Brake Switch8W-50-5
Fuse 17 (JB)8W-50-8, 9	Park Lamp Relay8W-50-8, 9
Fuse 18 (JB)8W-50-2	Power Distribution Center8W-50-2, 5, 7
Fuse 19 (PDC)8W-50-7	Right Fog Lamp8W-50-7
G1068W-50-3, 4, 7, 11	Right Front Park Lamp.8W-50-11
G1078W-50-5	Right Front Side Marker Lamp.8W-50-11
G1098W-50-4, 7, 10	Right Front Turn Signal Lamp8W-50-11
G3038W-50-6, 8, 12	Right Headlamp8W-50-3, 4
Headlamp Dimmer Switch8W-50-2	Right Headlamp Leveling Motor8W-50-12
Headlamp Leveling Switch8W-50-12	Right Side Repeater8W-50-11
Headlamp Switch8W-50-2, 6, 8	Turn Signal/Hazard Warning Switch. . .	.8W-50-10, 11

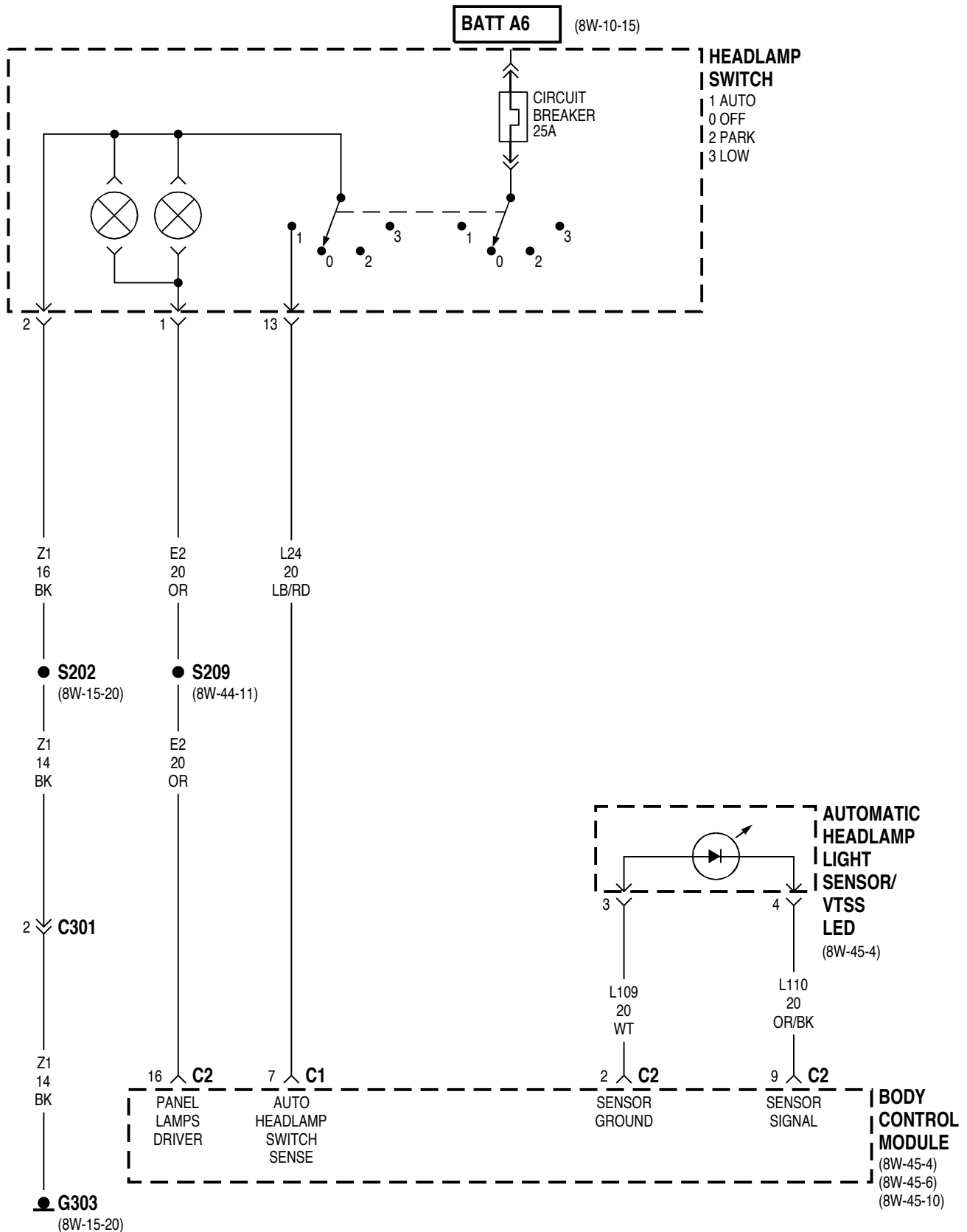


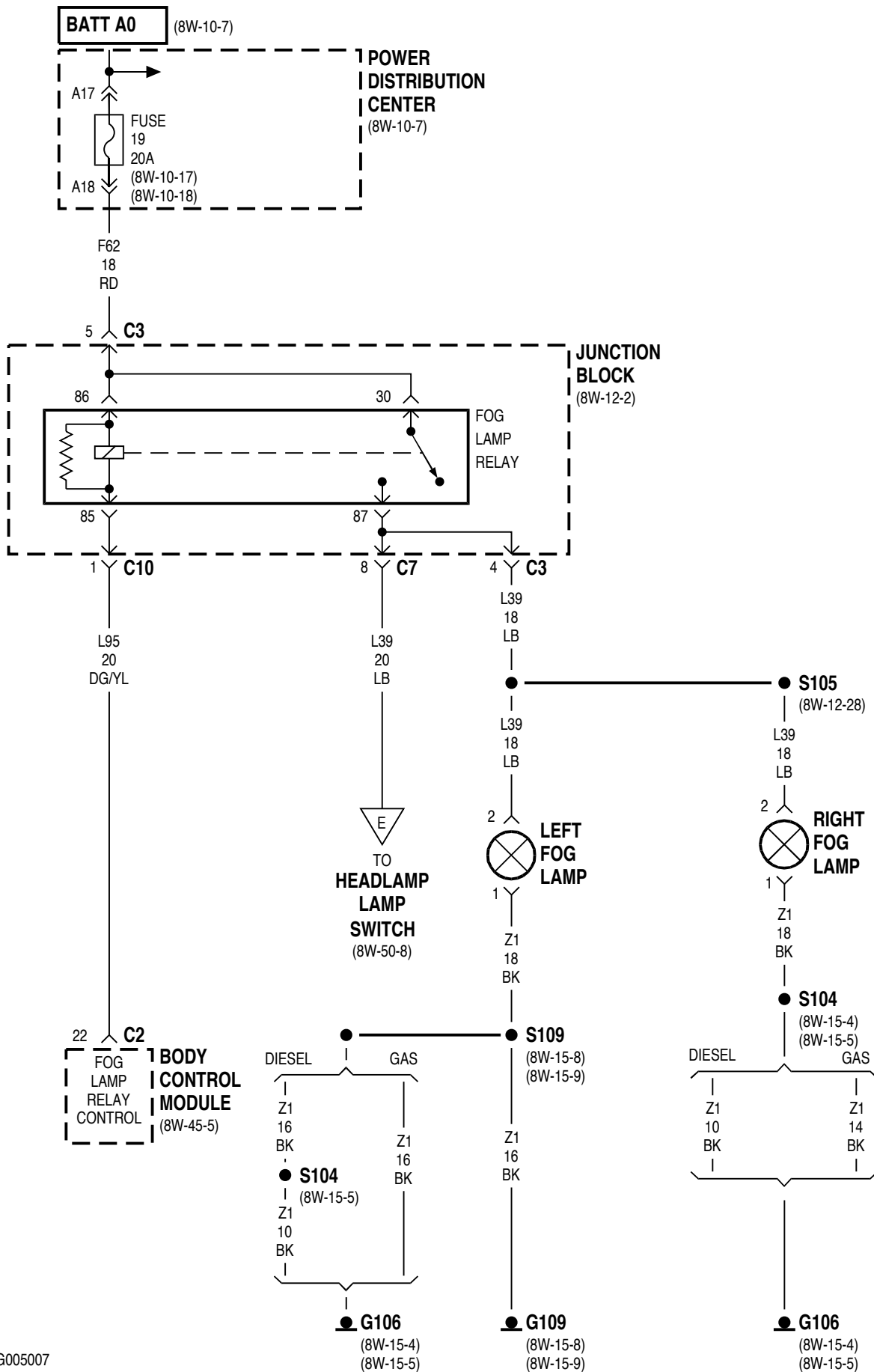


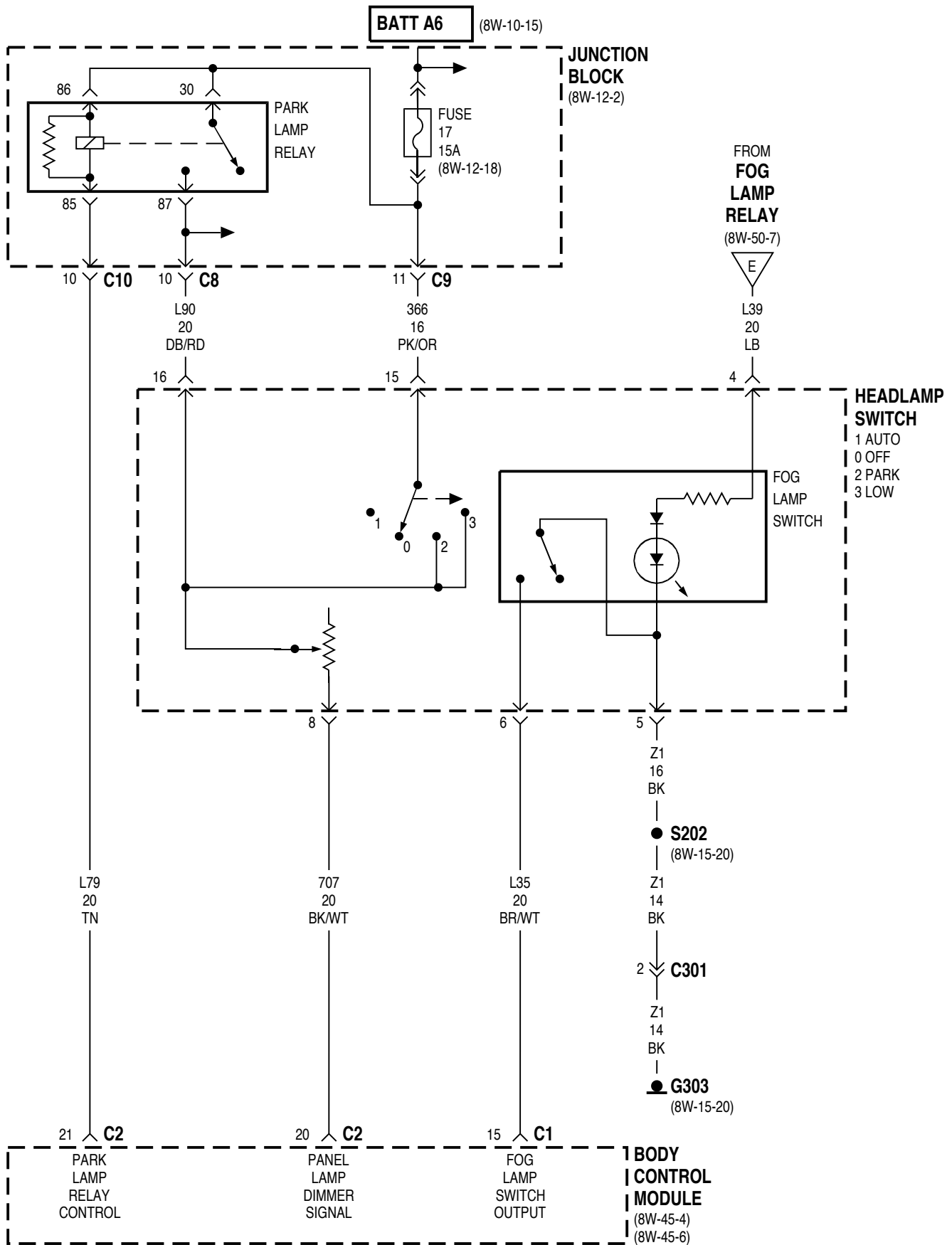


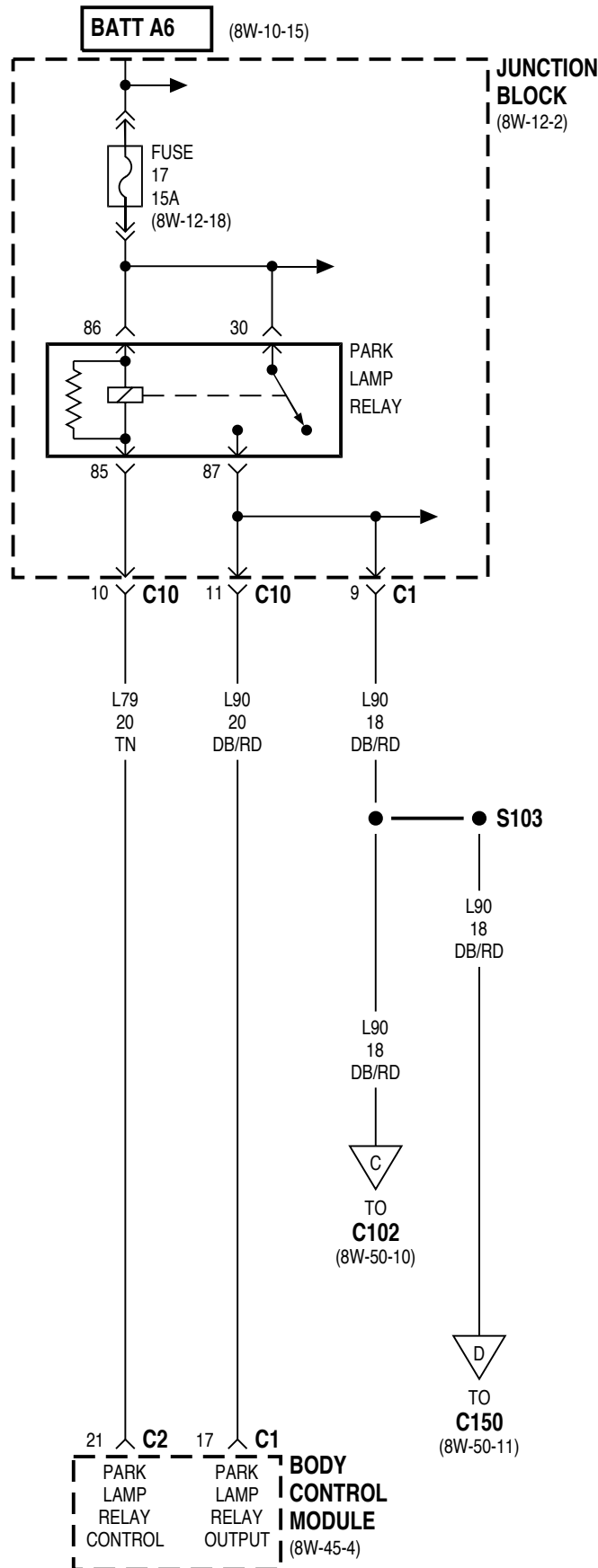
DRL

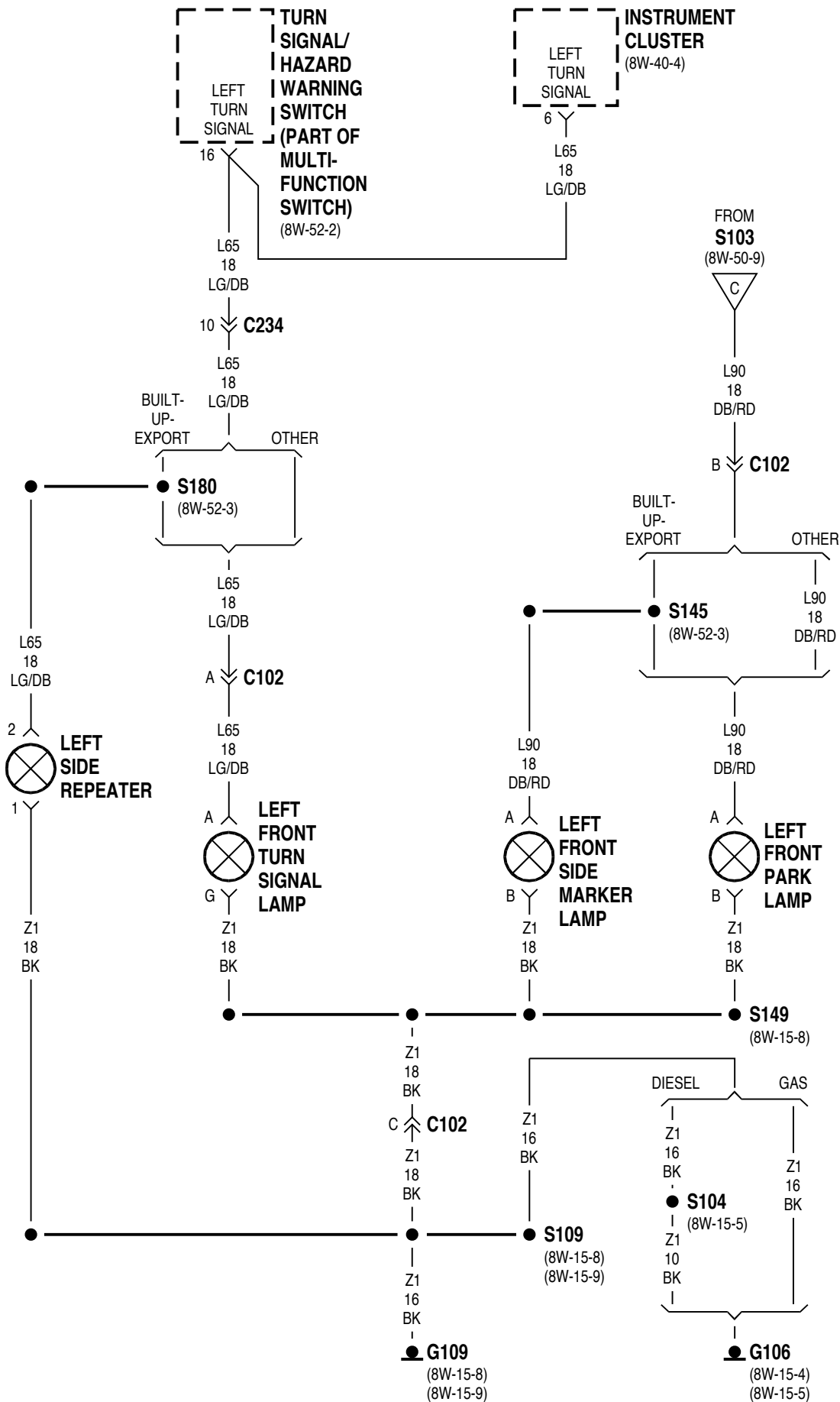


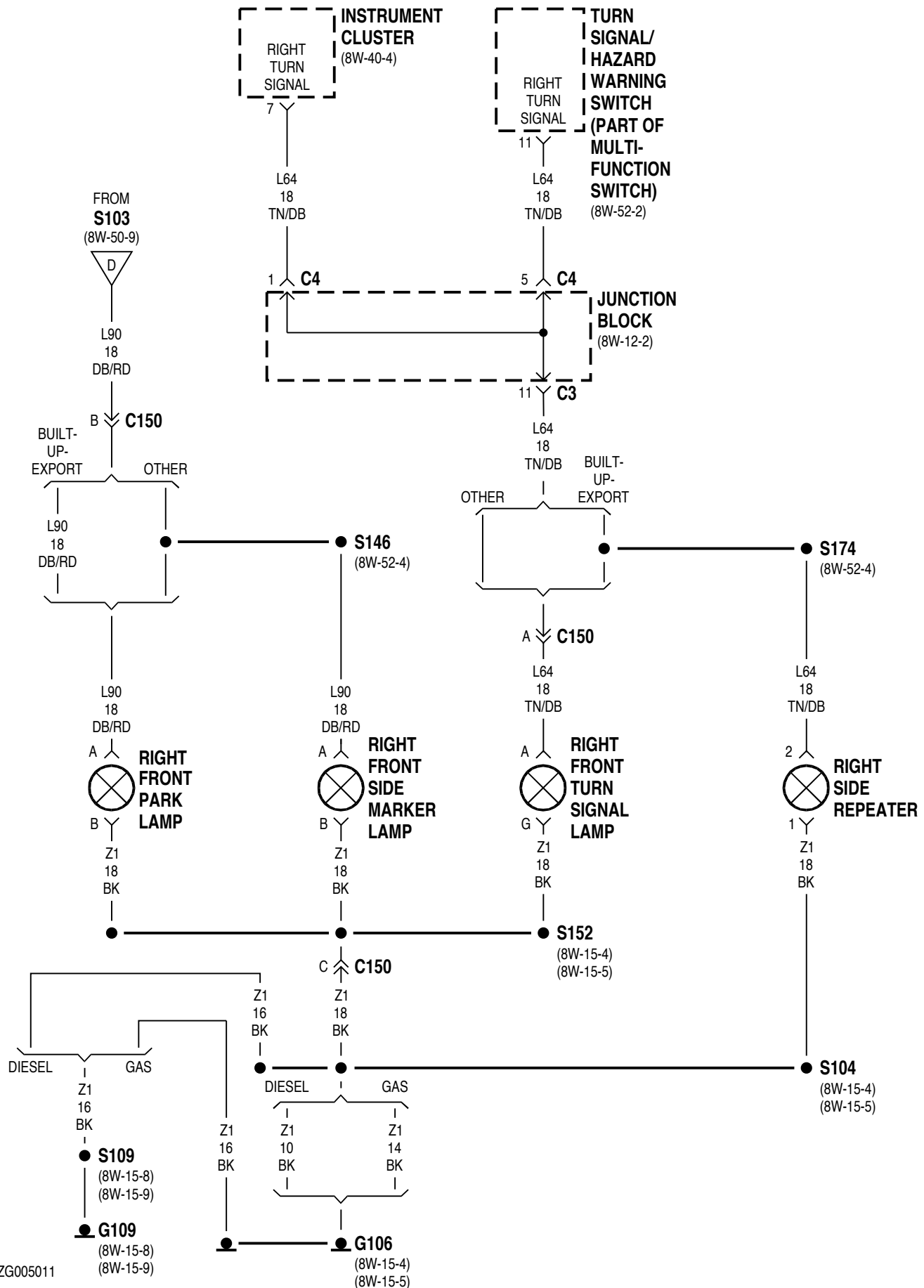


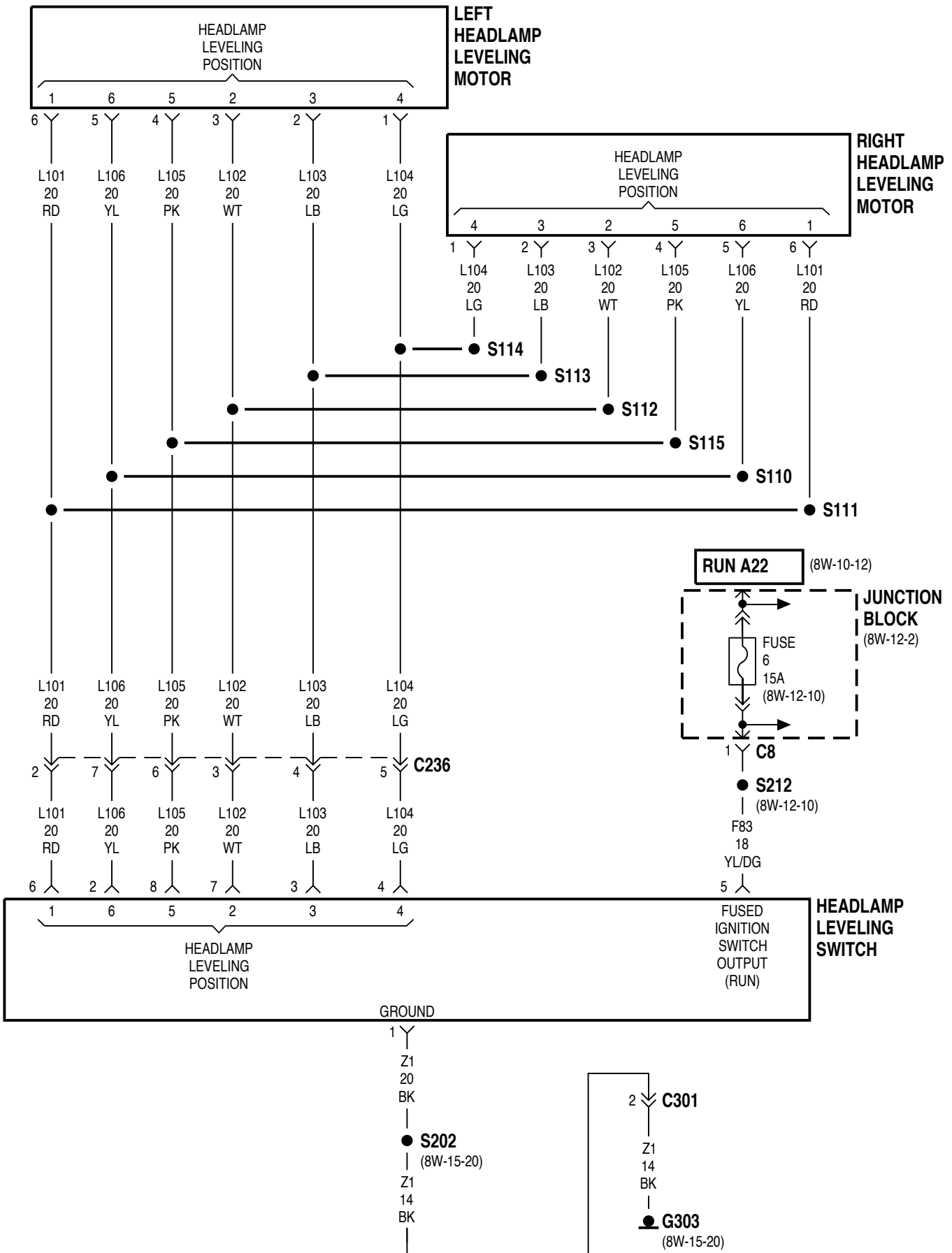






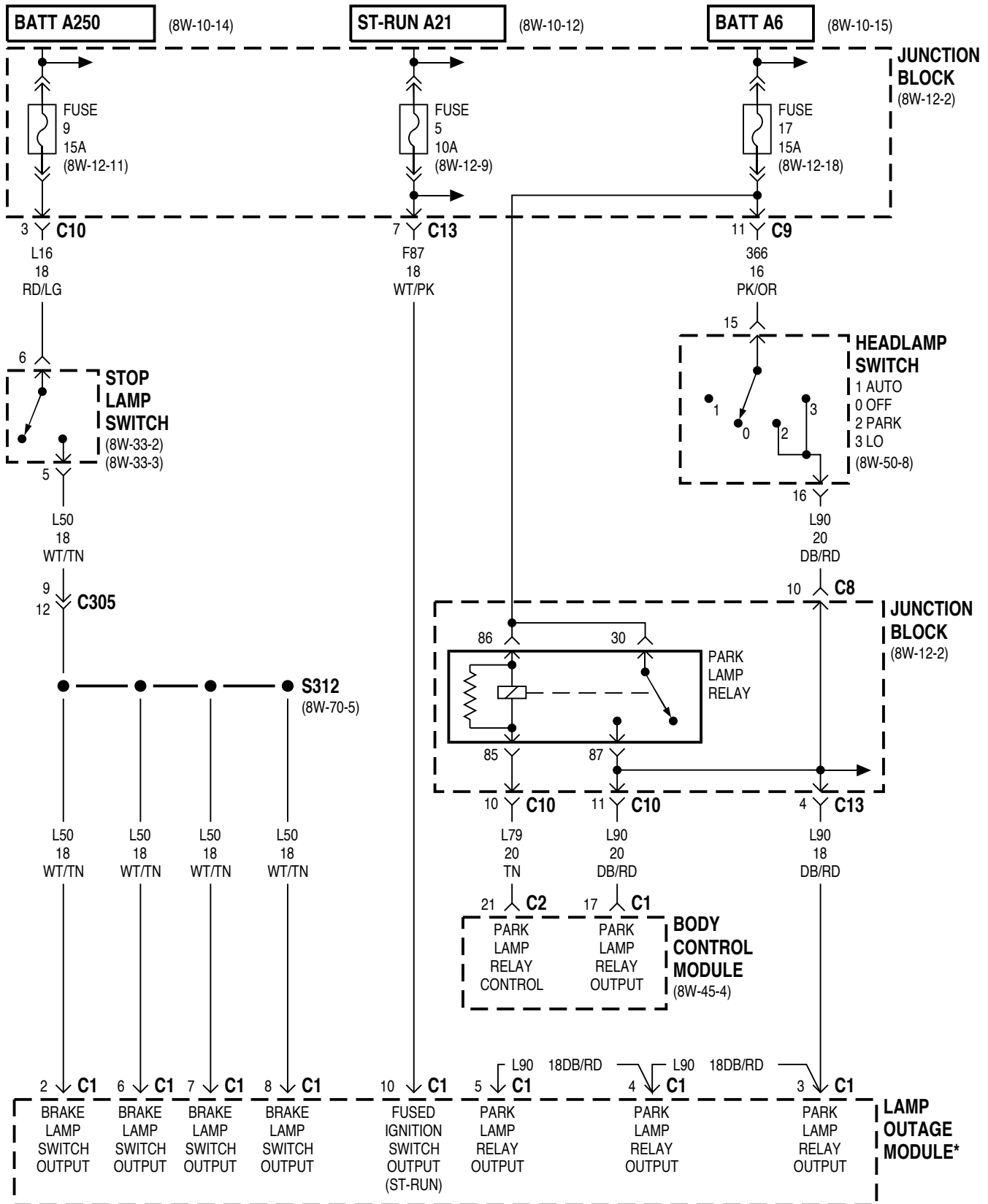




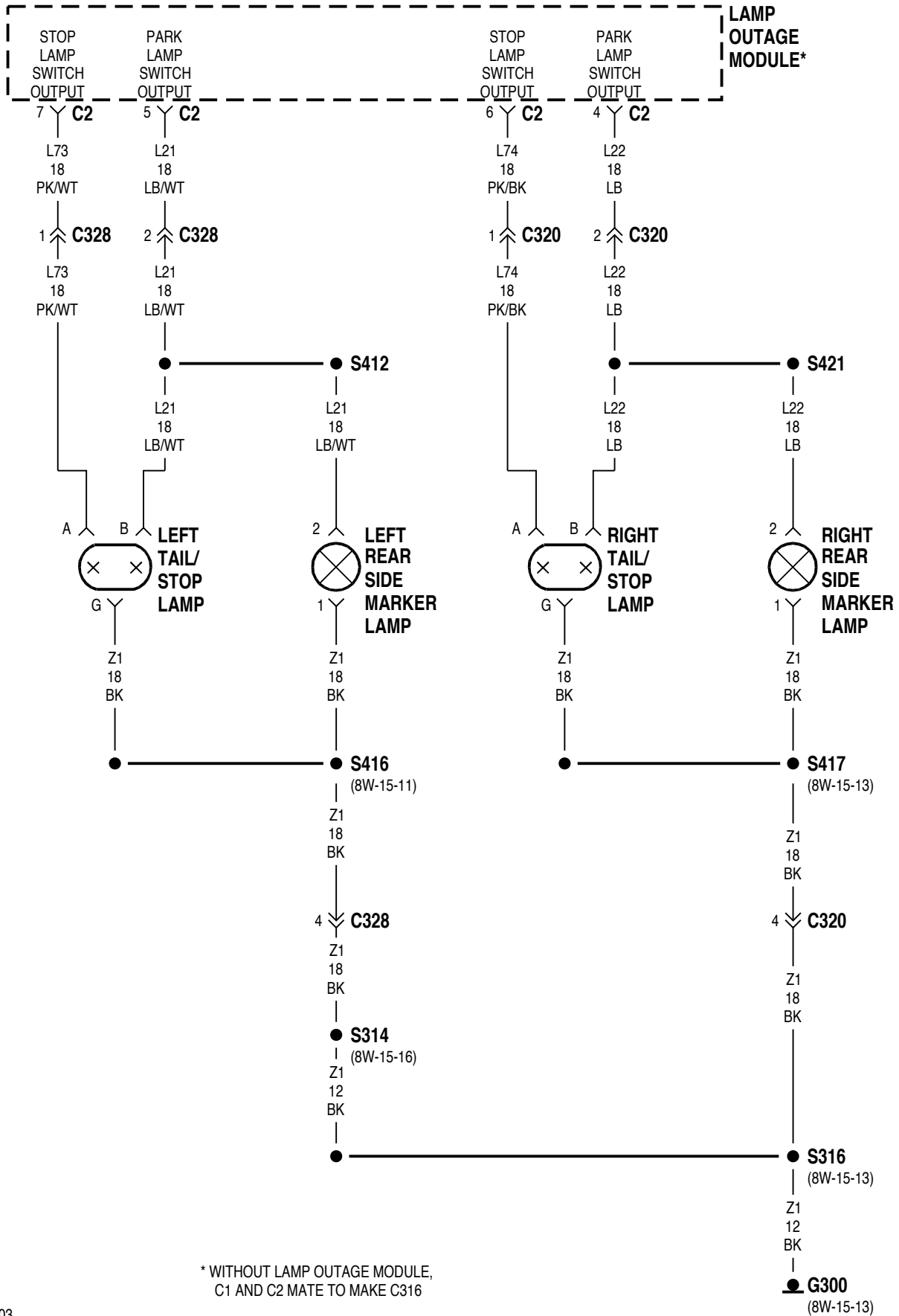


8W-51 REAR LIGHTING

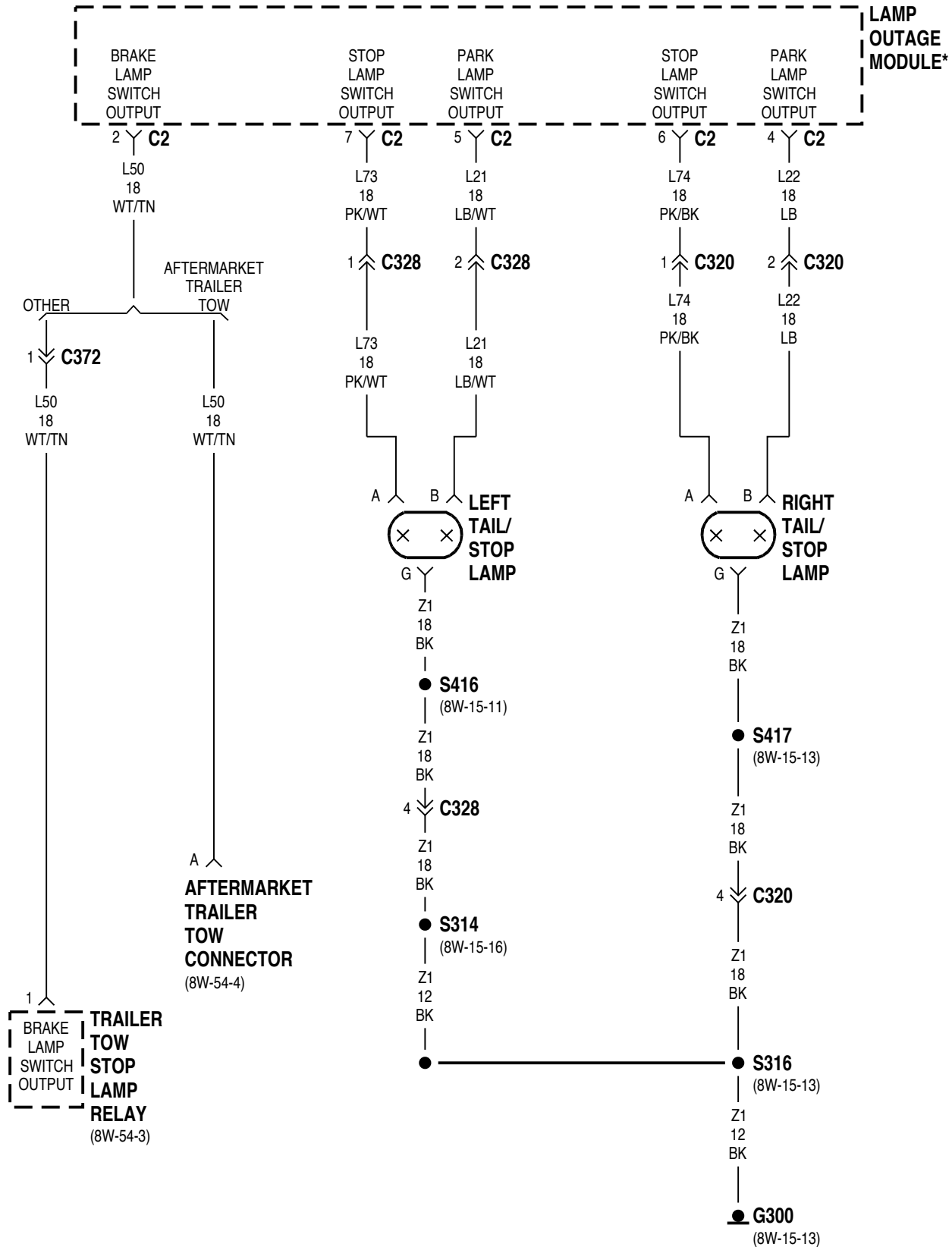
Component	Page	Component	Page
Aftermarket Trailer Tow Connector	8W-51-4, 6	Lamp Outage Module	8W-51-2, 3, 4, 5, 6, 7
Back-Up Lamp Switch	8W-51-5	Left Back-Up Lamp	8W-51-6
Body Control Module	8W-51-2	Left License Lamp	8W-51-6
Center High Mounted Stop Lamp No. 1	8W-51-5	Left Rear Fog Lamp	8W-51-7
Center High Mounted Stop Lamp No. 2	8W-51-5	Left Rear Side Marker Lamp	8W-51-3
Center High Mounted Stop Lamp No. 3	8W-51-5	Left Tail/Stop Lamp	8W-51-3, 4
Factory Trailer Tow Connector	8W-51-6	Park Lamp Relay	8W-51-2
Fuse 5 (JB)	8W-51-2	Park/Neutral Position Switch	8W-51-5
Fuse 6 (JB)	8W-51-5	Rear Fog Lamp Relay	8W-51-7
Fuse 9 (JB)	8W-51-2	Right Back-Up Lamp	8W-51-6
Fuse 15 (JB)	8W-51-7	Right License Lamp	8W-51-6
Fuse 17 (JB)	8W-51-2, 7	Right Rear Fog Lamp	8W-51-7
G300	8W-51-3, 4, 5, 6, 7	Right Rear Side Marker Lamp	8W-51-3
G302	8W-51-5, 6	Right Tail/Stop Lamp	8W-51-3, 4
G303	8W-51-7	Stop Lamp Switch	8W-51-2
Headlamp Switch	8W-51-2, 7	Trailer Tow Stop Lamp Relay	8W-51-4
Junction Block	8W-51-2, 5, 6, 7	Vehicle Information Center/ Graphic Display Module	8W-51-5



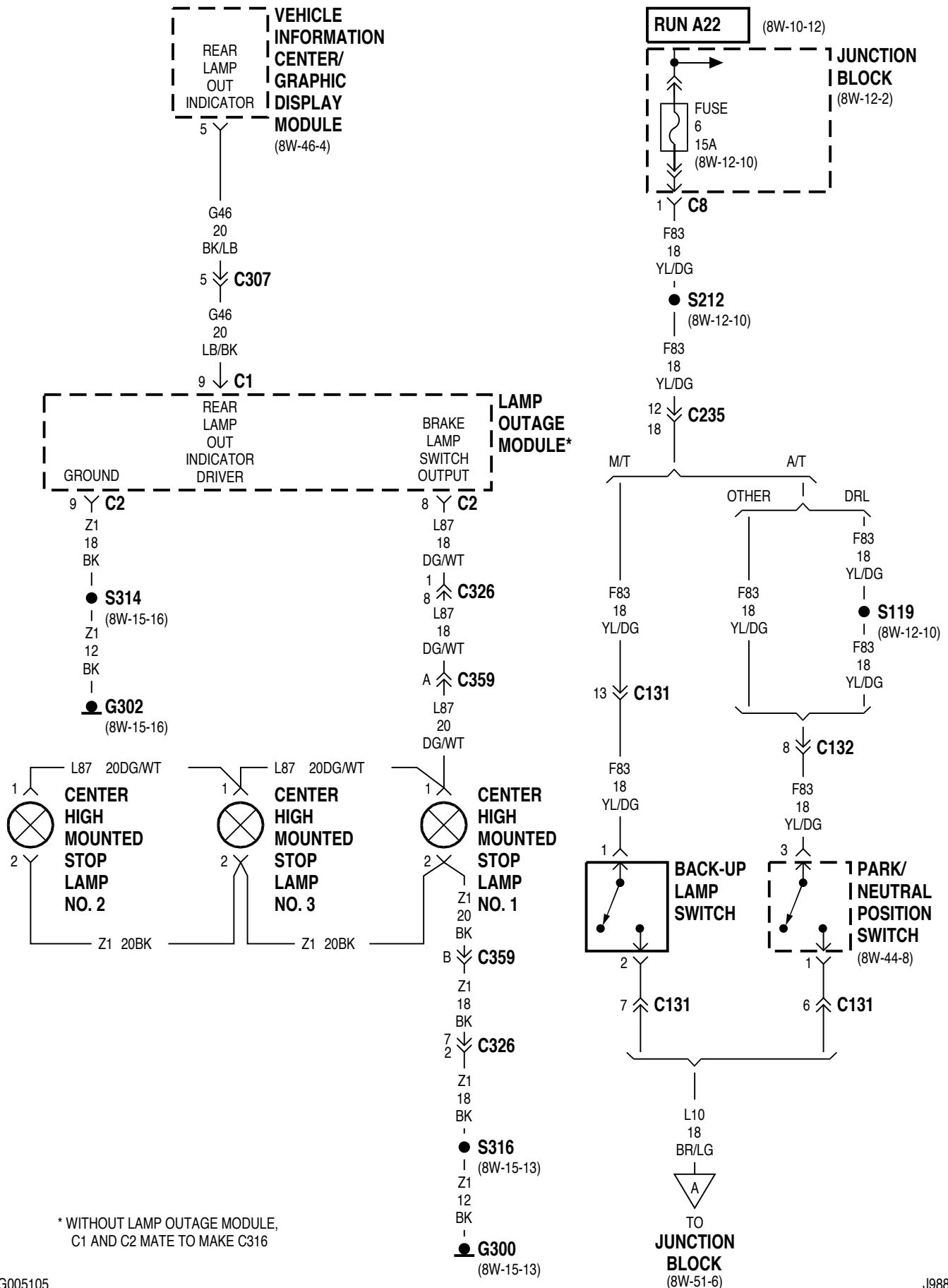
* WITHOUT LAMP OUTAGE MODULE,
C1 AND C2 MATE TO MAKE C316



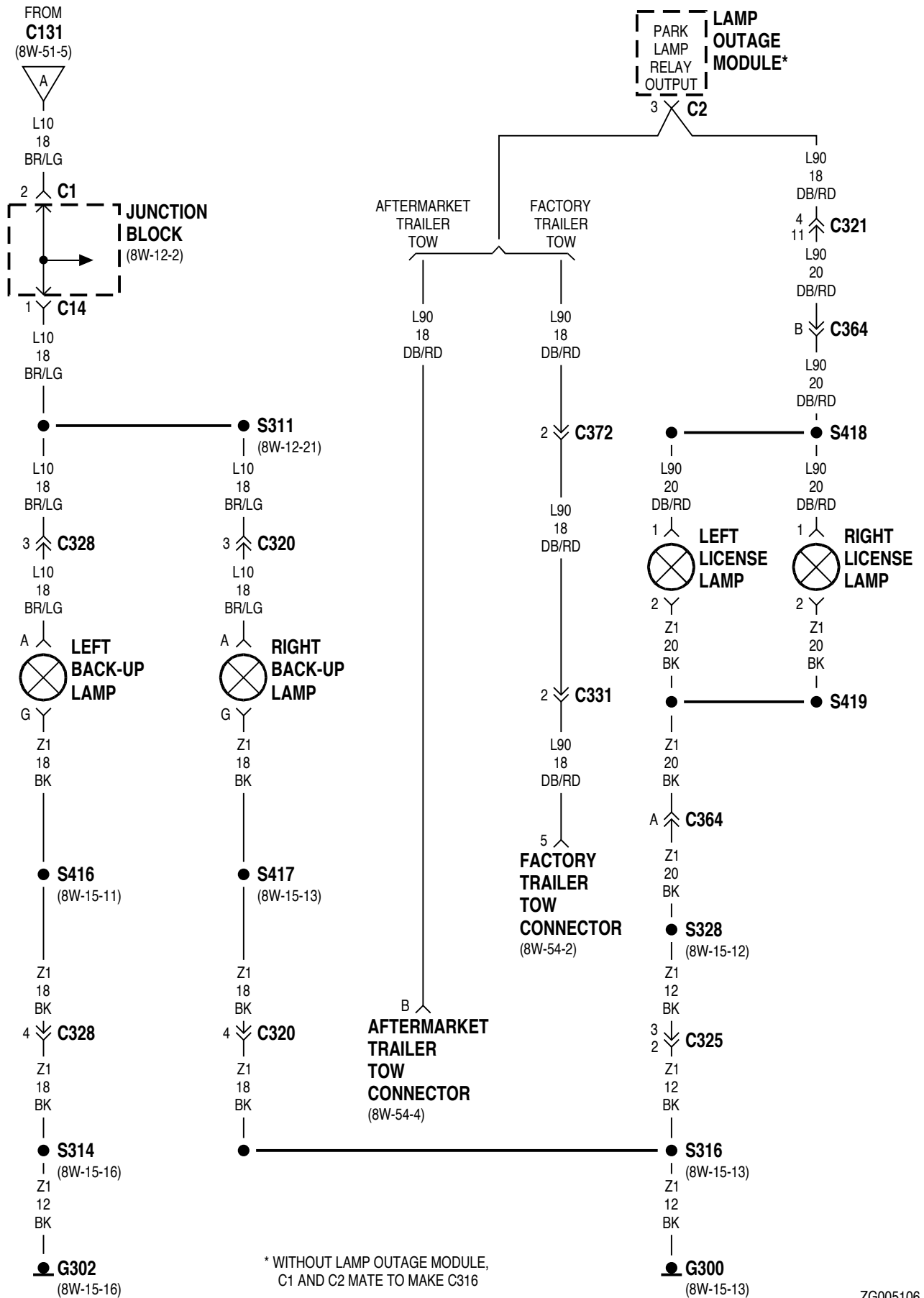
* WITHOUT LAMP OUTAGE MODULE,
C1 AND C2 MATE TO MAKE C316

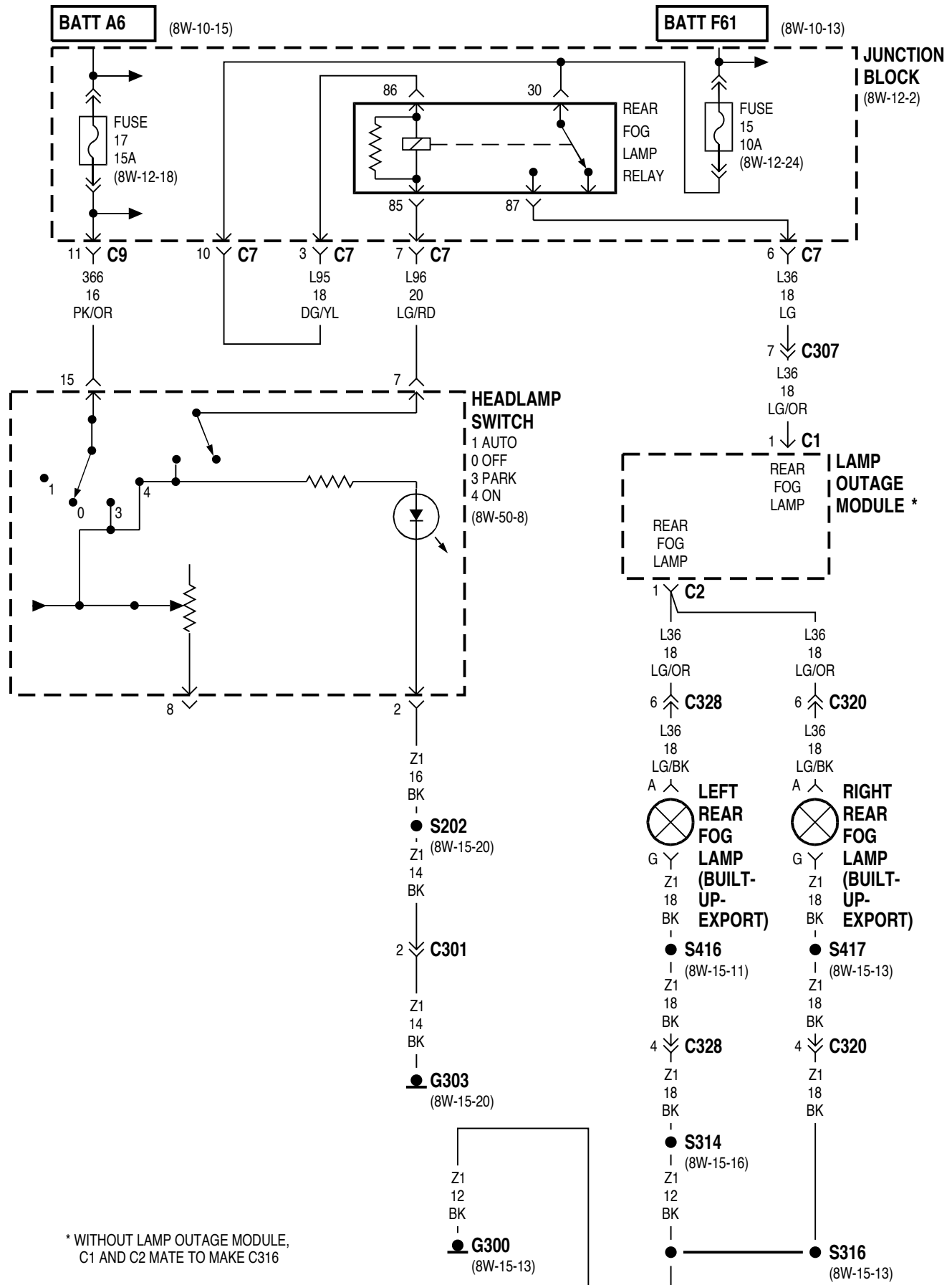


* WITHOUT LAMP OUTAGE MODULE,
C1 AND C2 MATE TO MAKE C316



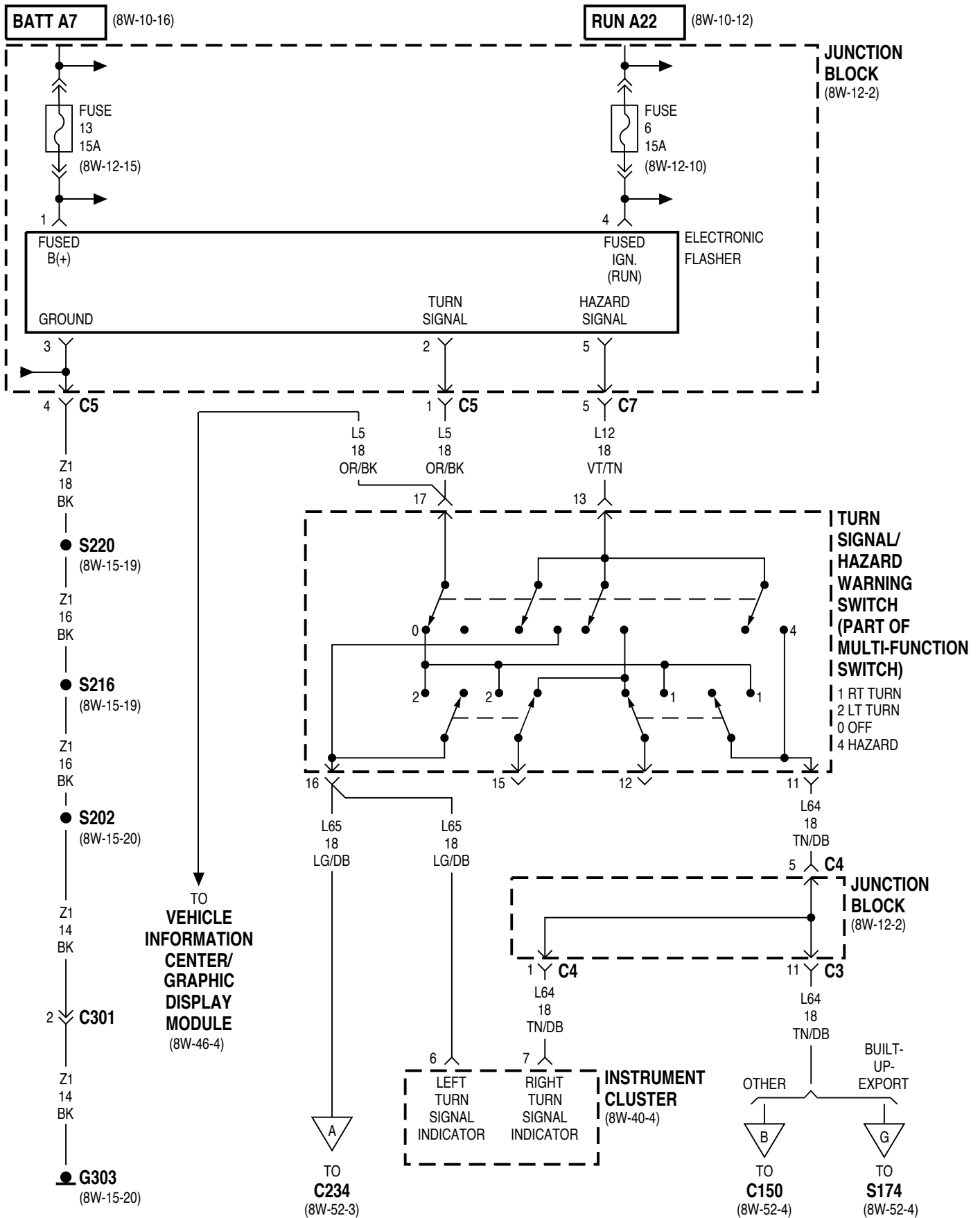
* WITHOUT LAMP OUTAGE MODULE, C1 AND C2 MATE TO MAKE C316

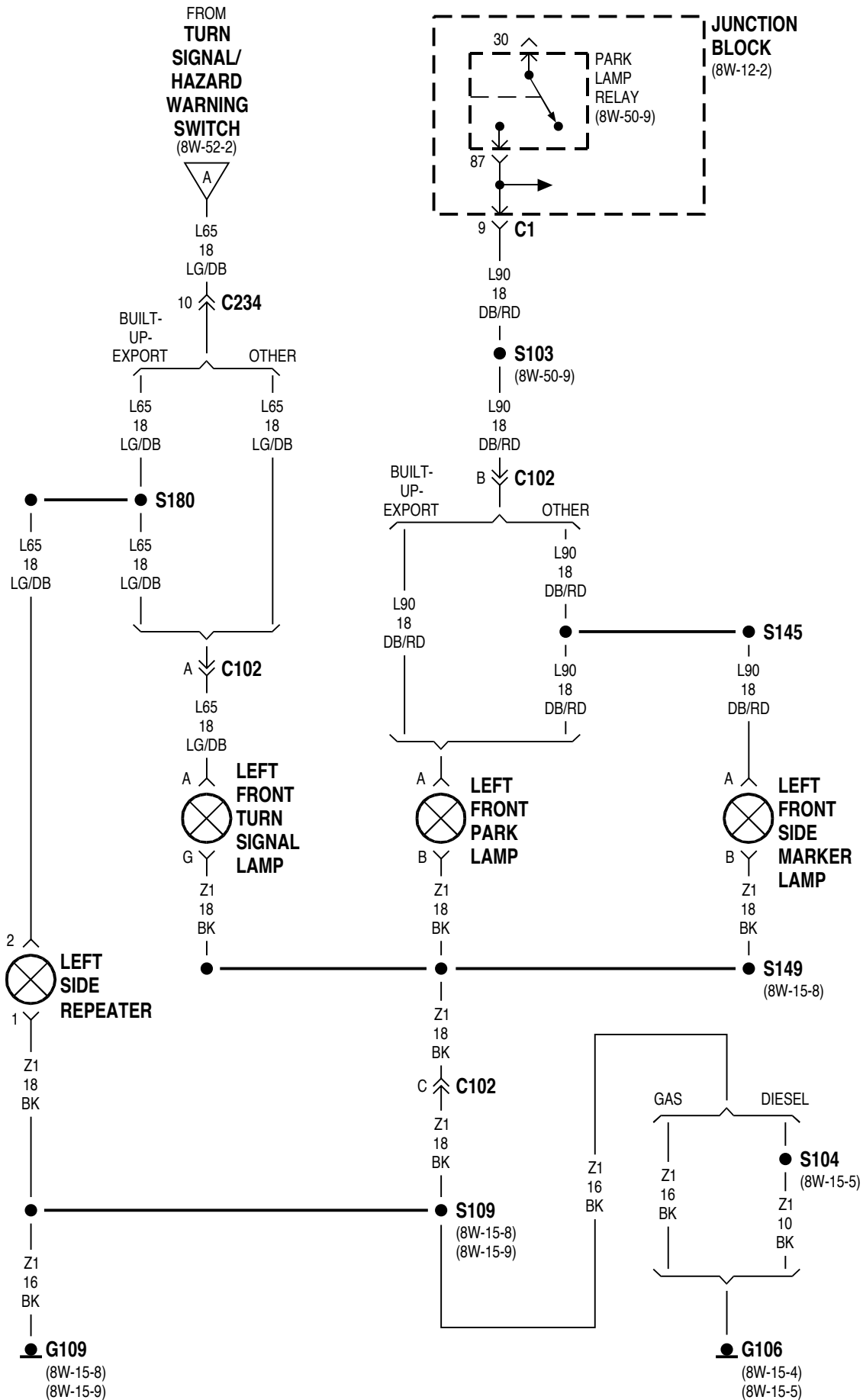


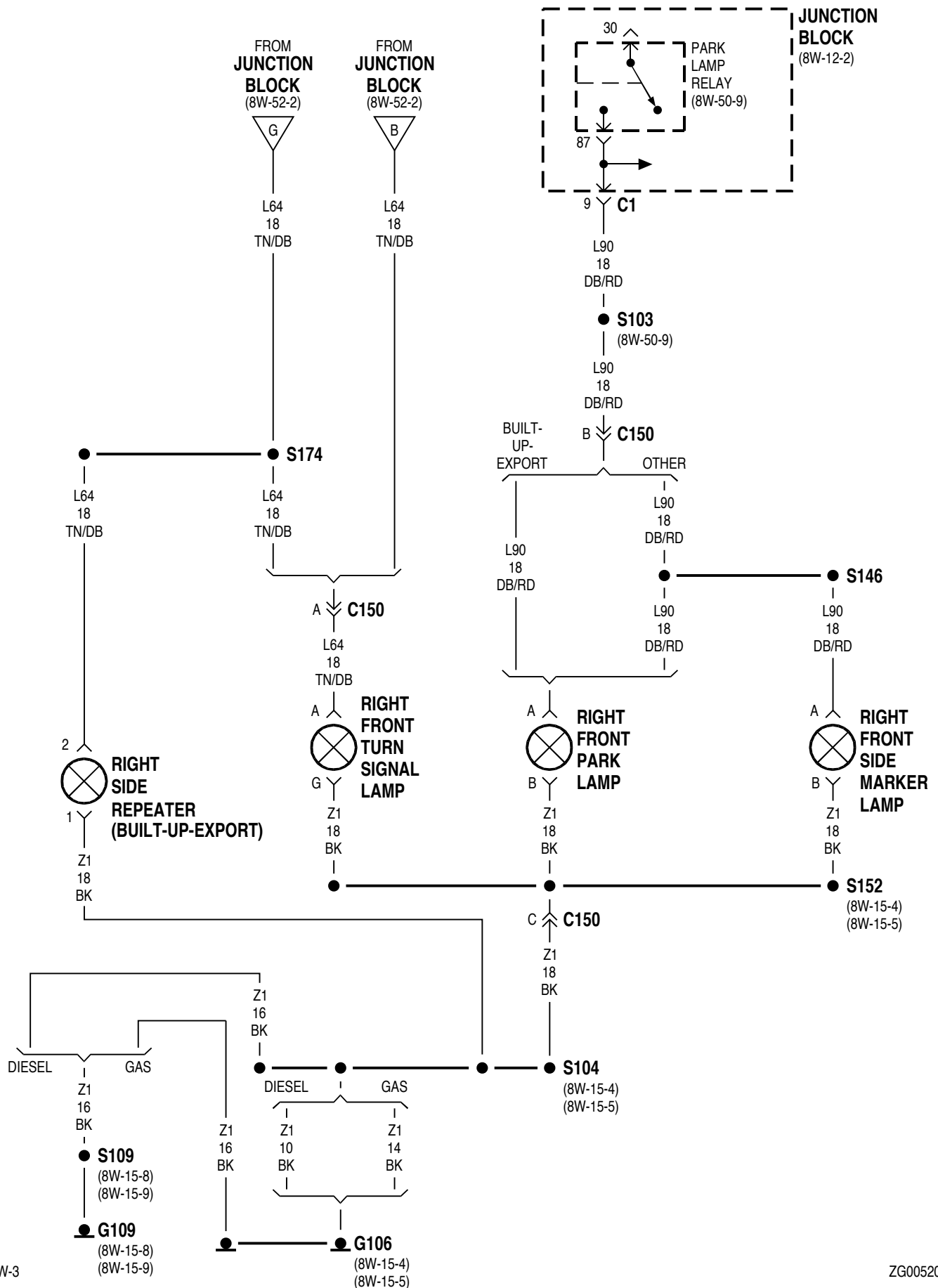


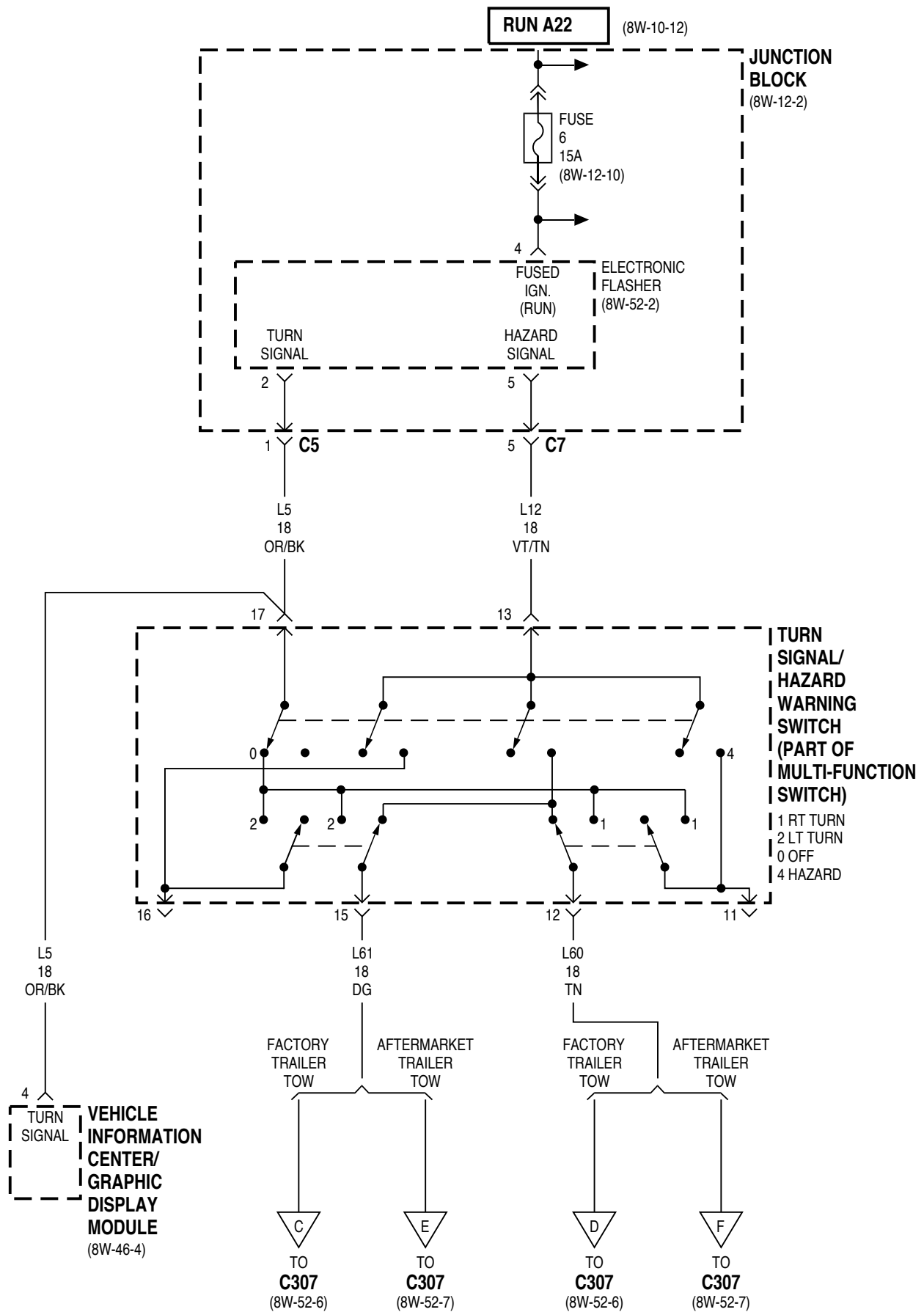
8W-52 TURN SIGNALS

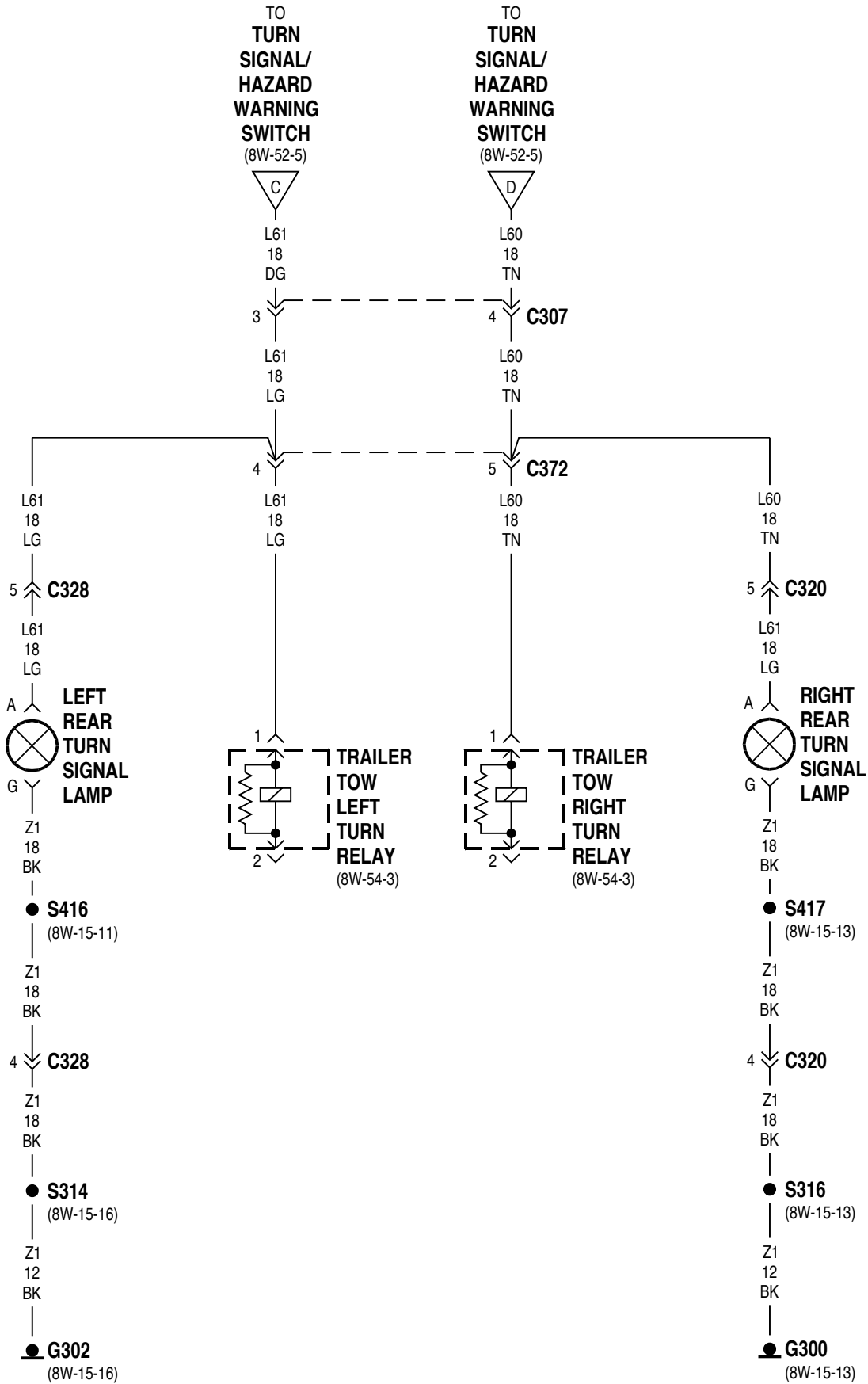
Component	Page	Component	Page
Aftermarket Trailer Tow Connector8W-52-7	Left Front Turn Signal Lamp8W-52-3
Electronic Flasher8W-52-2, 5	Left Rear Turn Signal Lamp8W-52-6, 7
Fuse 6 (JB)8W-52-2, 5	Left Side Repeater8W-52-3
Fuse 8 (JB)8W-52-7	Park Lamp Relay8W-52-3, 4
Fuse 13 (JB)8W-52-2	Right Front Park Lamp8W-52-4
G1068W-52-4	Right Front Side Marker Lamp8W-52-4
G1098W-52-3	Right Front Turn Signal Lamp8W-52-4
G3008W-52-6, 7	Right Rear Turn Signal Lamp8W-52-6, 7
G3028W-52-6, 7	Right Side Repeater8W-52-4
G3038W-52-2	Trailer Tow Left Turn Relay8W-52-6
Instrument Cluster8W-52-2	Trailer Tow Right Turn Relay8W-52-6
Junction Block8W-52-2, 3, 4, 5, 7	Turn Signal/Hazard Warning Switch8W-52-2, 5
Left Front Park Lamp8W-52-3	Vehicle Information Center/ Graphic Display Module8W-52-2, 5
Left Front Side Marker Lamp8W-52-3		

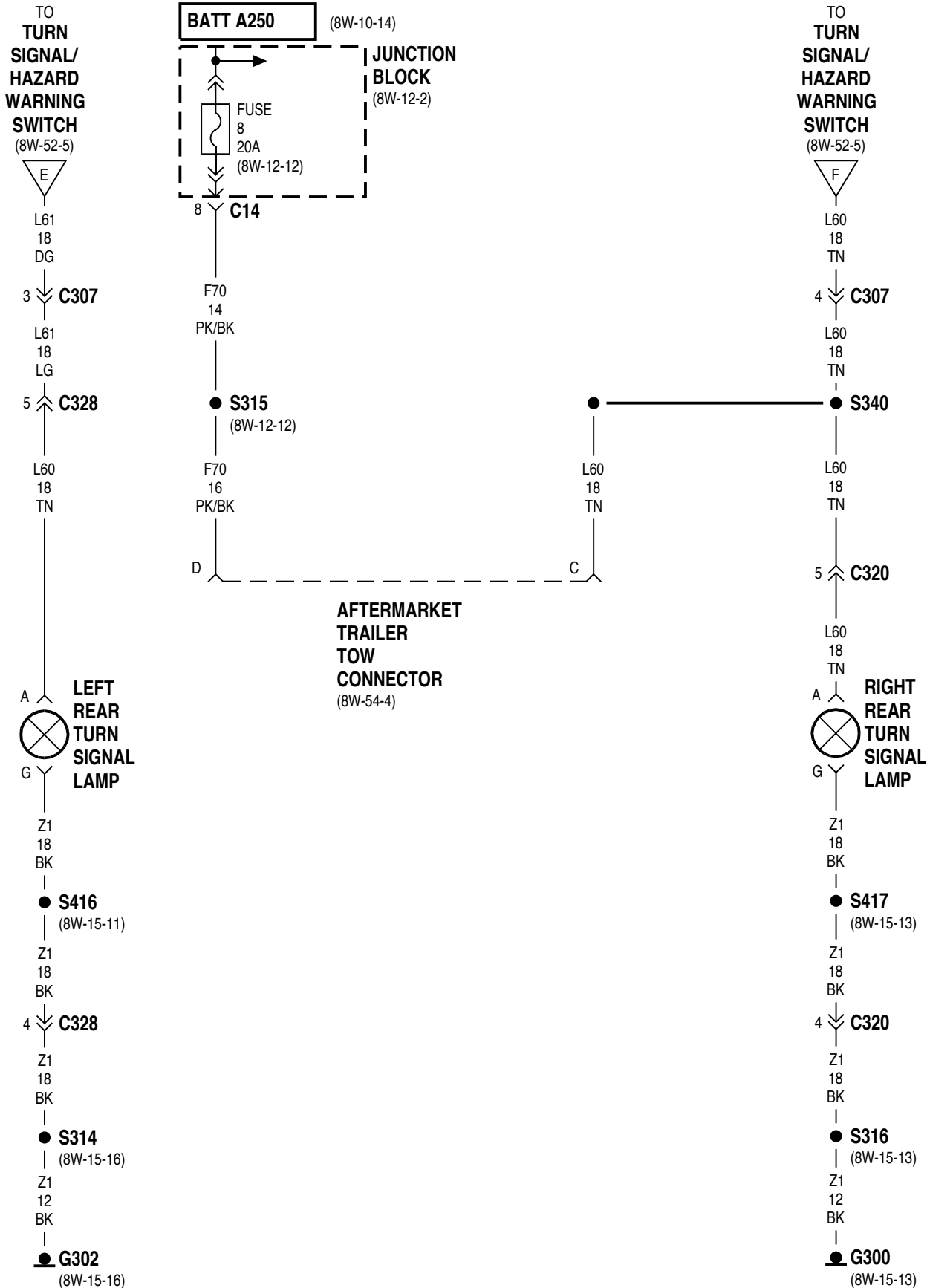






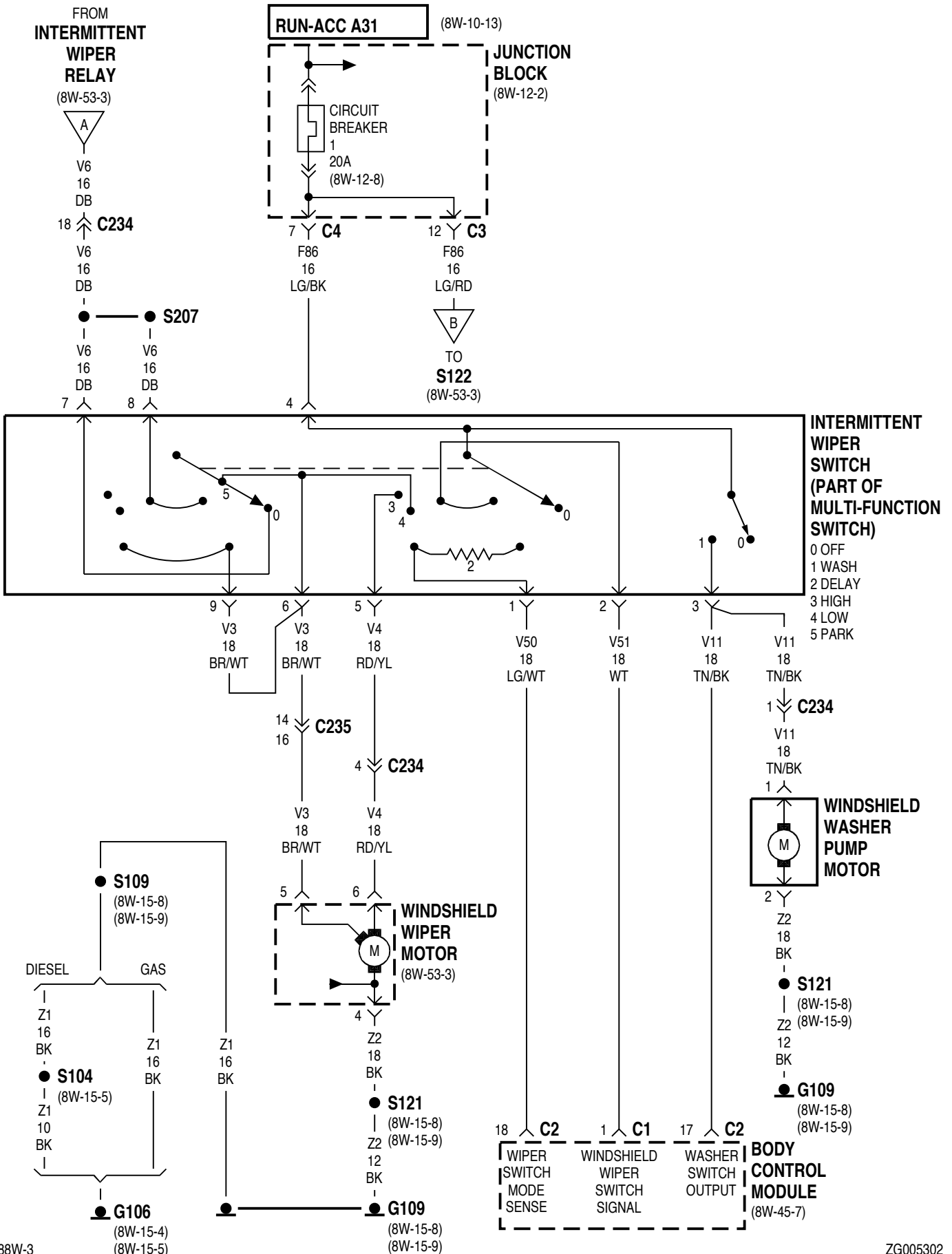


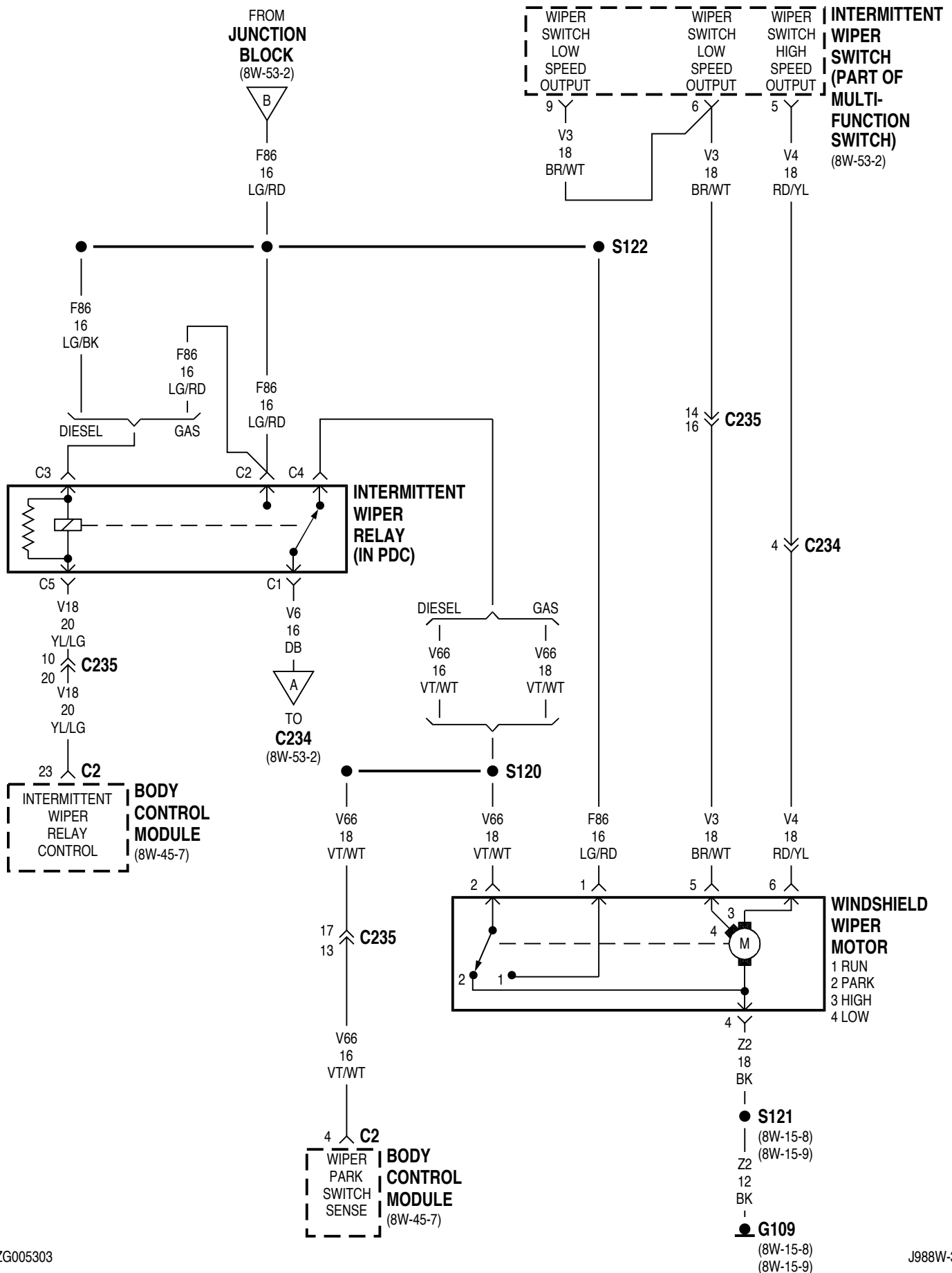


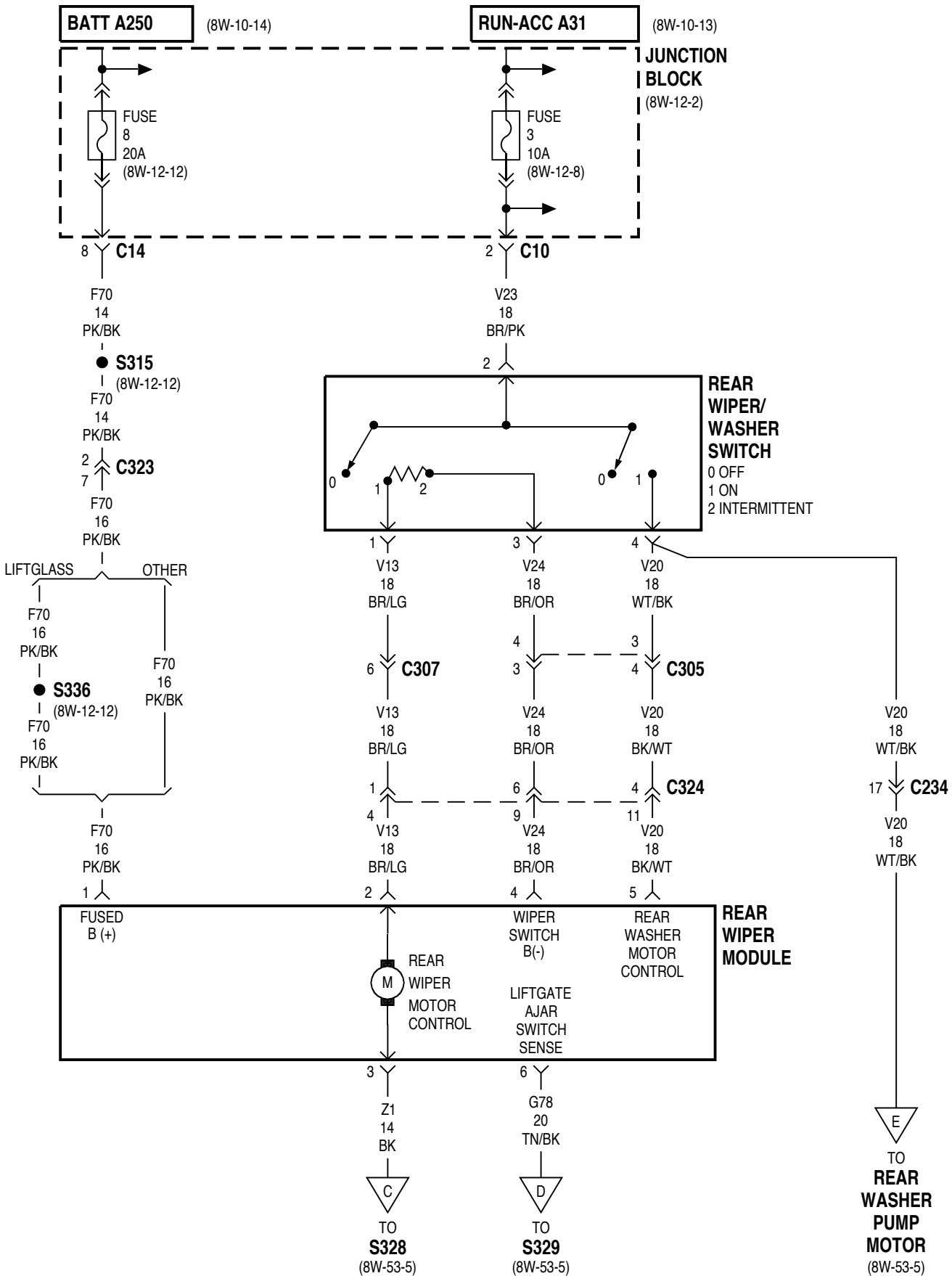


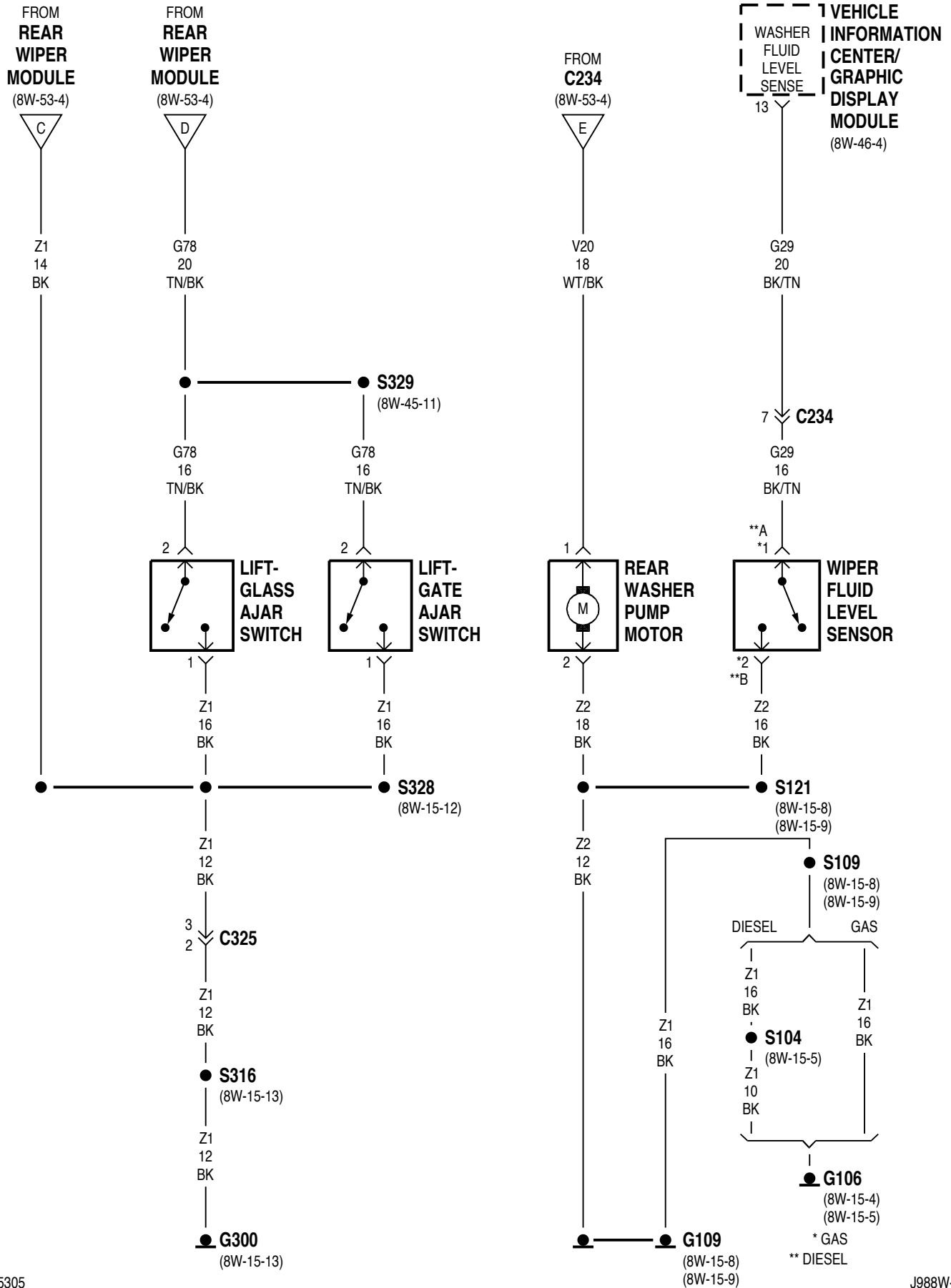
8W-53 WIPERS

Component	Page	Component	Page
Body Control Module	8W-53-2, 3	Liftglass Ajar Switch.	8W-53-5
Circuit Breaker 1	8W-53-2	Rear Washer Pump Motor.	8W-53-5
Fuse 3 (JB)	8W-53-4	Rear Wiper Module.	8W-53-4
Fuse 8 (JB)	8W-53-4	Rear Wiper Motor Control	8W-53-4
G109	8W-53-2, 3, 5	Rear Wiper/Washer Switch	8W-53-4
G300	8W-53-5	Vehicle Information Center/ Graphic Display Module	8W-53-5
Intermittent Wiper Relay	8W-53-3	Windshield Washer Pump Motor.	8W-53-2
Intermittent Wiper Switch	8W-53-2, 3	Windshield Wiper Motor	8W-53-2, 3
Junction Block	8W-53-2, 4	Wiper Fluid Level Sensor	8W-53-5
Liftgate Ajar Switch	8W-53-5		



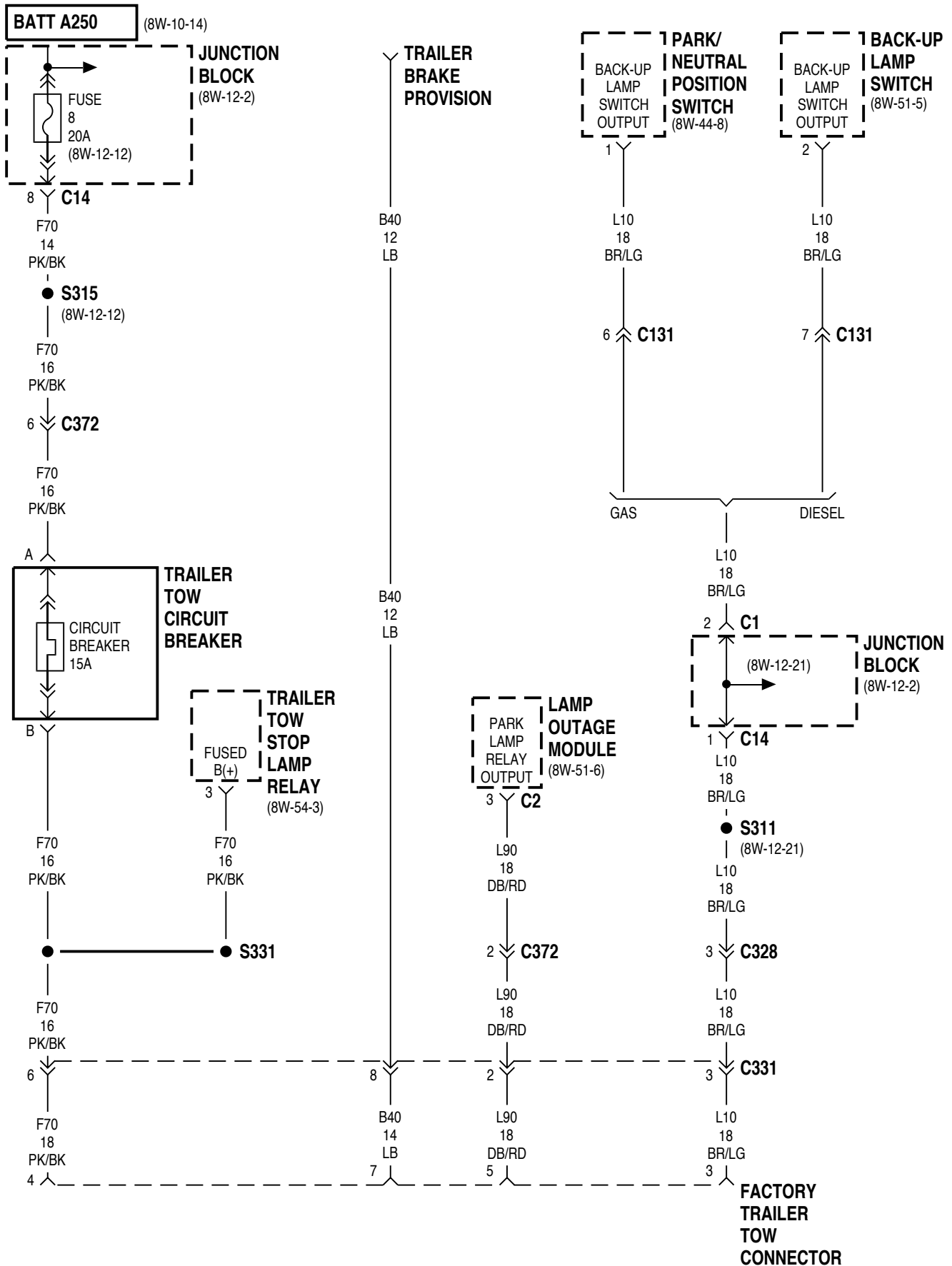


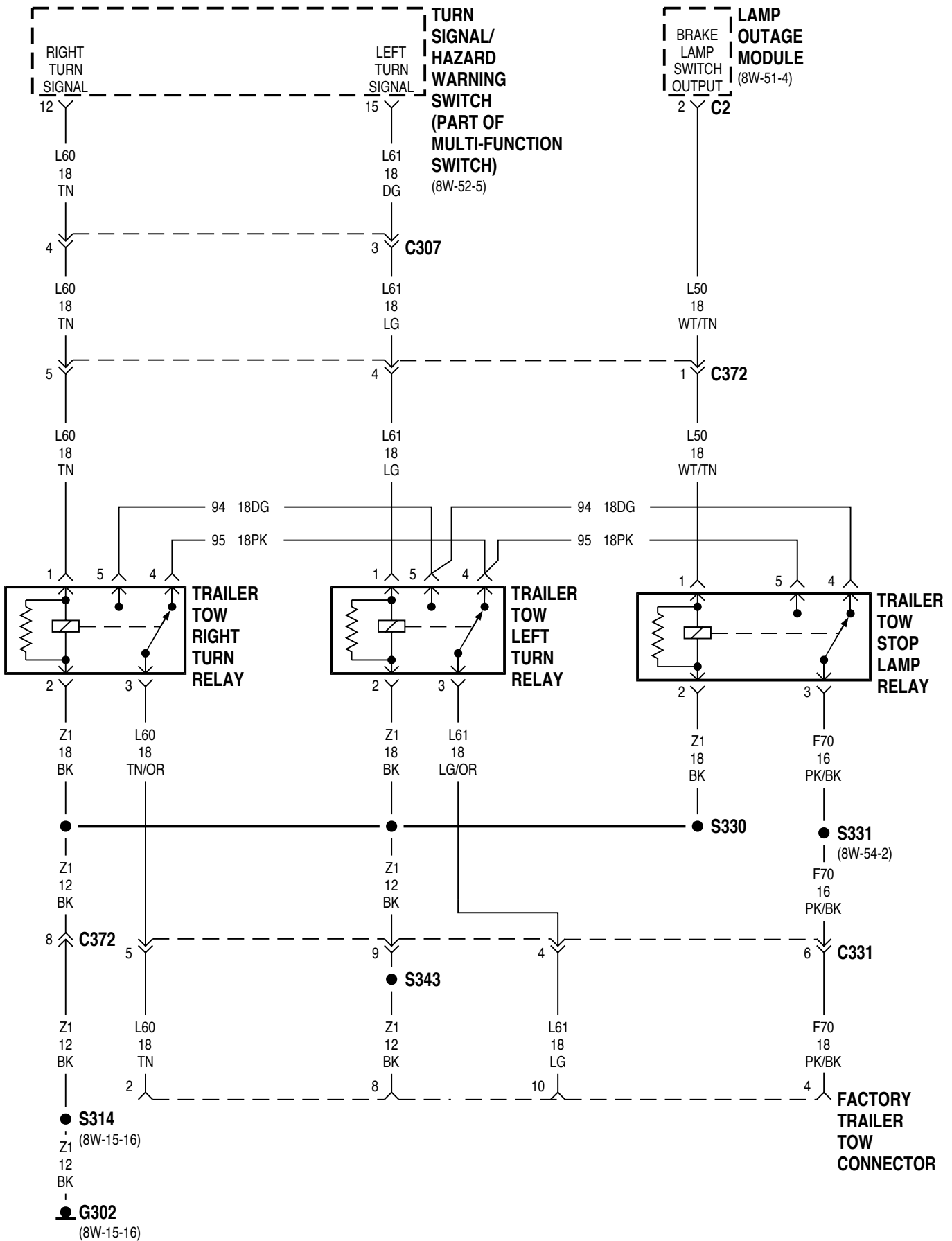


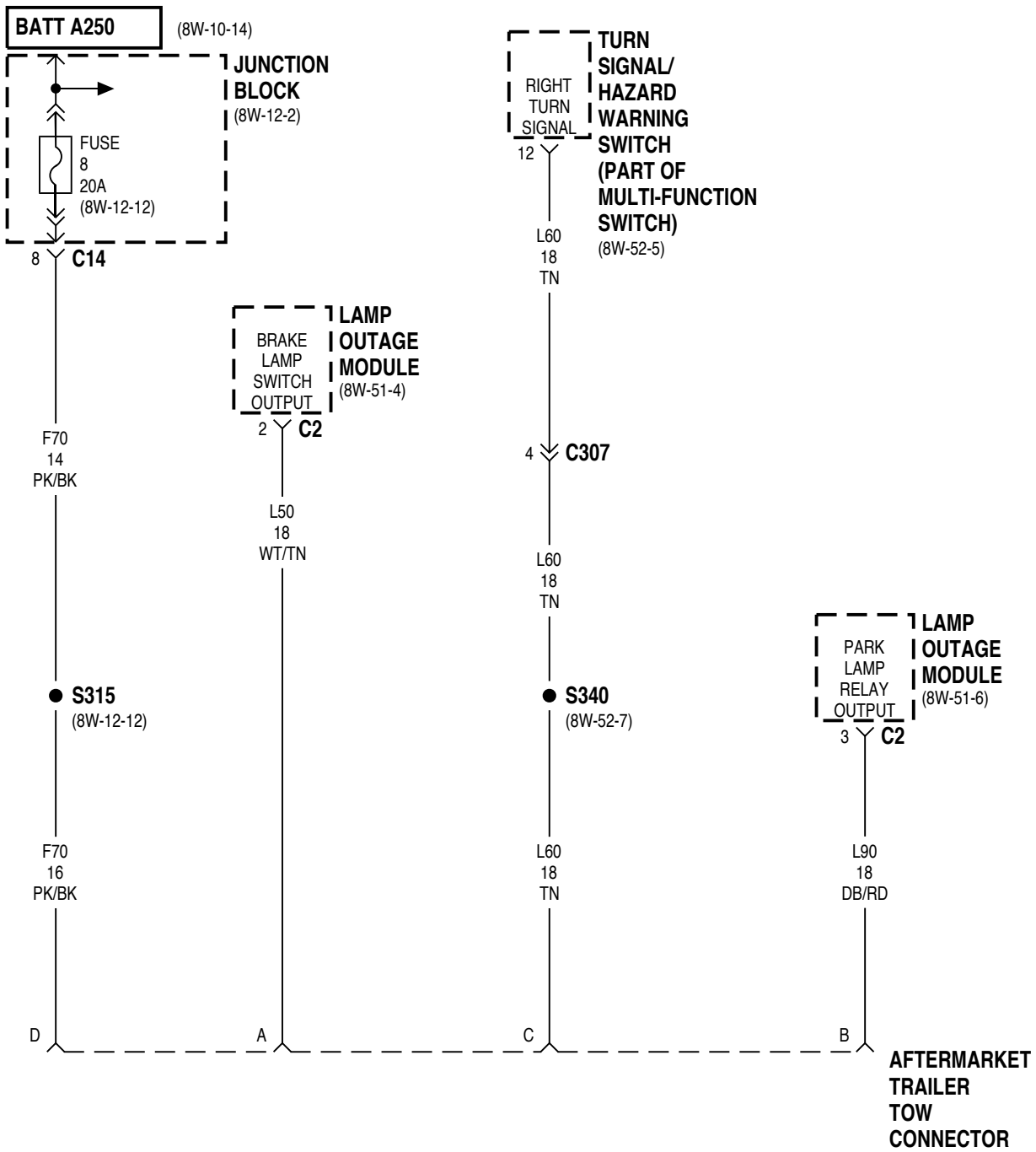


8W-54 TRAILER TOW

Component	Page	Component	Page
Aftermarket Trailer Tow Connector	8W-54-4	Park/Neutral Position Switch	8W-54-2
Back-Up Lamp Switch	8W-54-2	Trailer Brake Provision.	8W-54-2
Factory Trailer Tow Connector	8W-54-2, 3	Trailer Tow Circuit Breaker	8W-54-2
Fuse 8 (JB)	8W-54-2, 4	Trailer Tow Left Turn Relay	8W-54-3
G302	8W-54-3	Trailer Tow Right Turn Relay	8W-54-3
Junction Block	8W-54-2, 4	Trailer Tow Stop Lamp Relay	8W-54-2, 3
Lamp Outage Module	8W-54-2, 3, 4	Turn Signal/Hazard Warning Switch	8W-54-3, 4

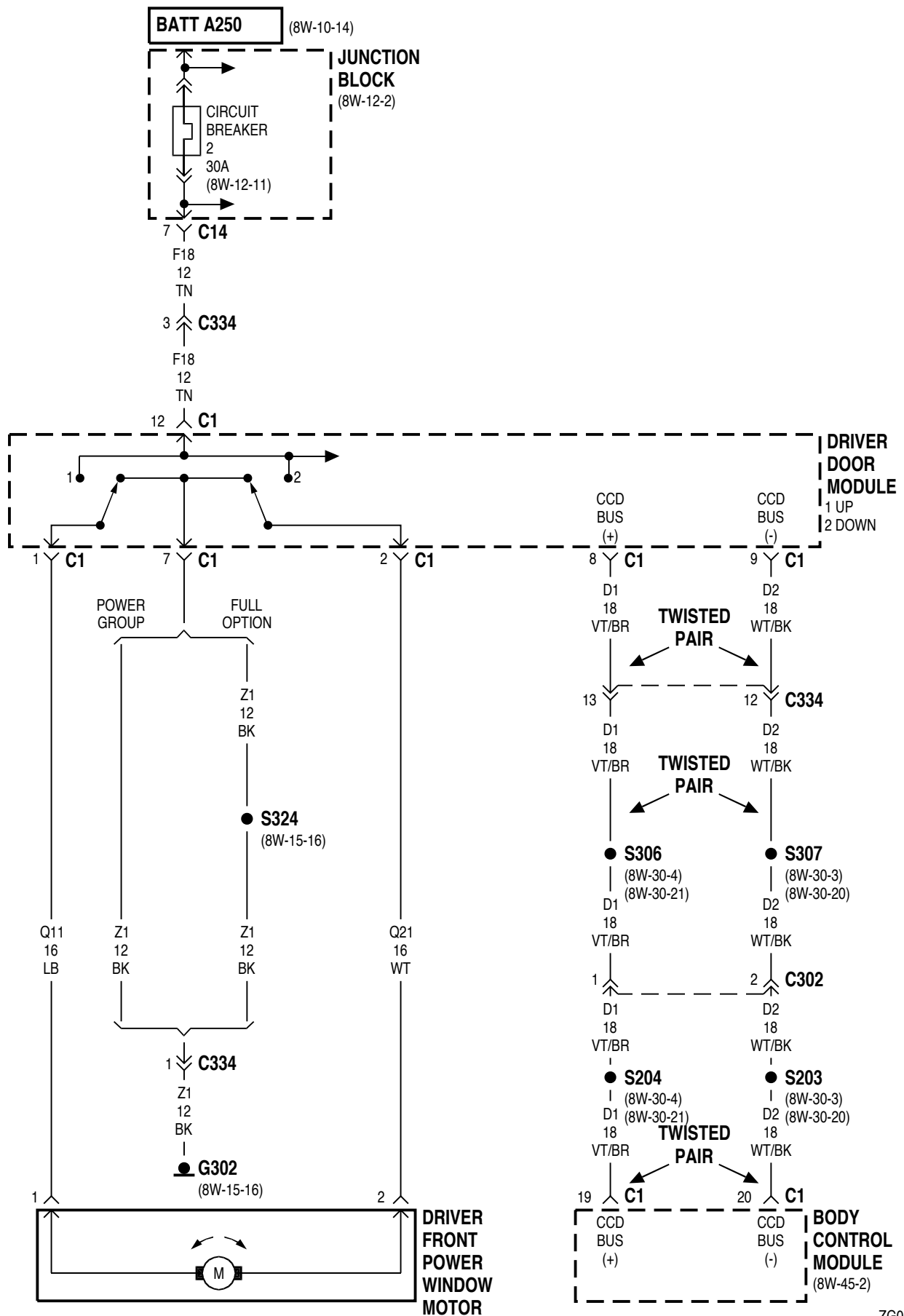


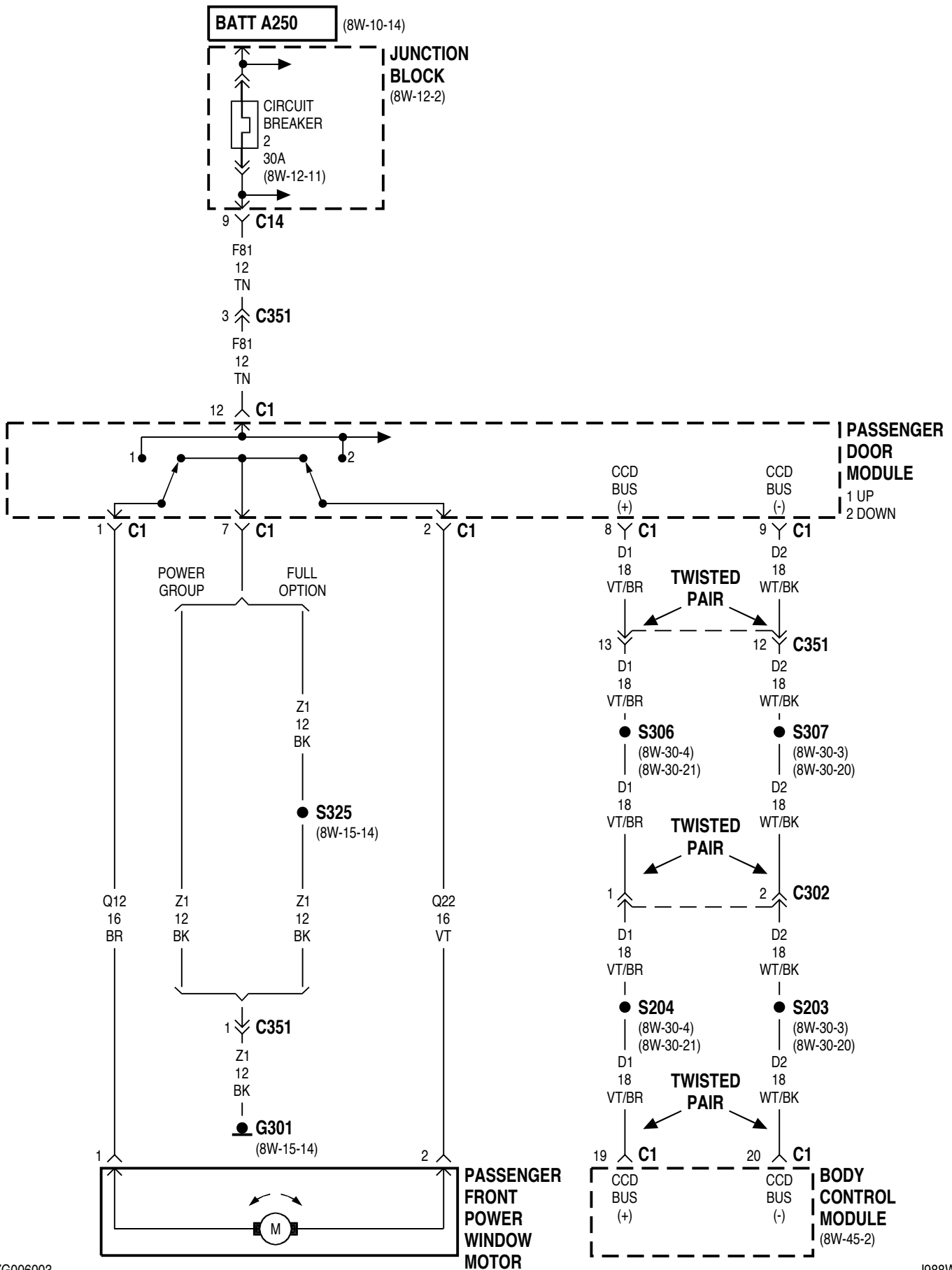


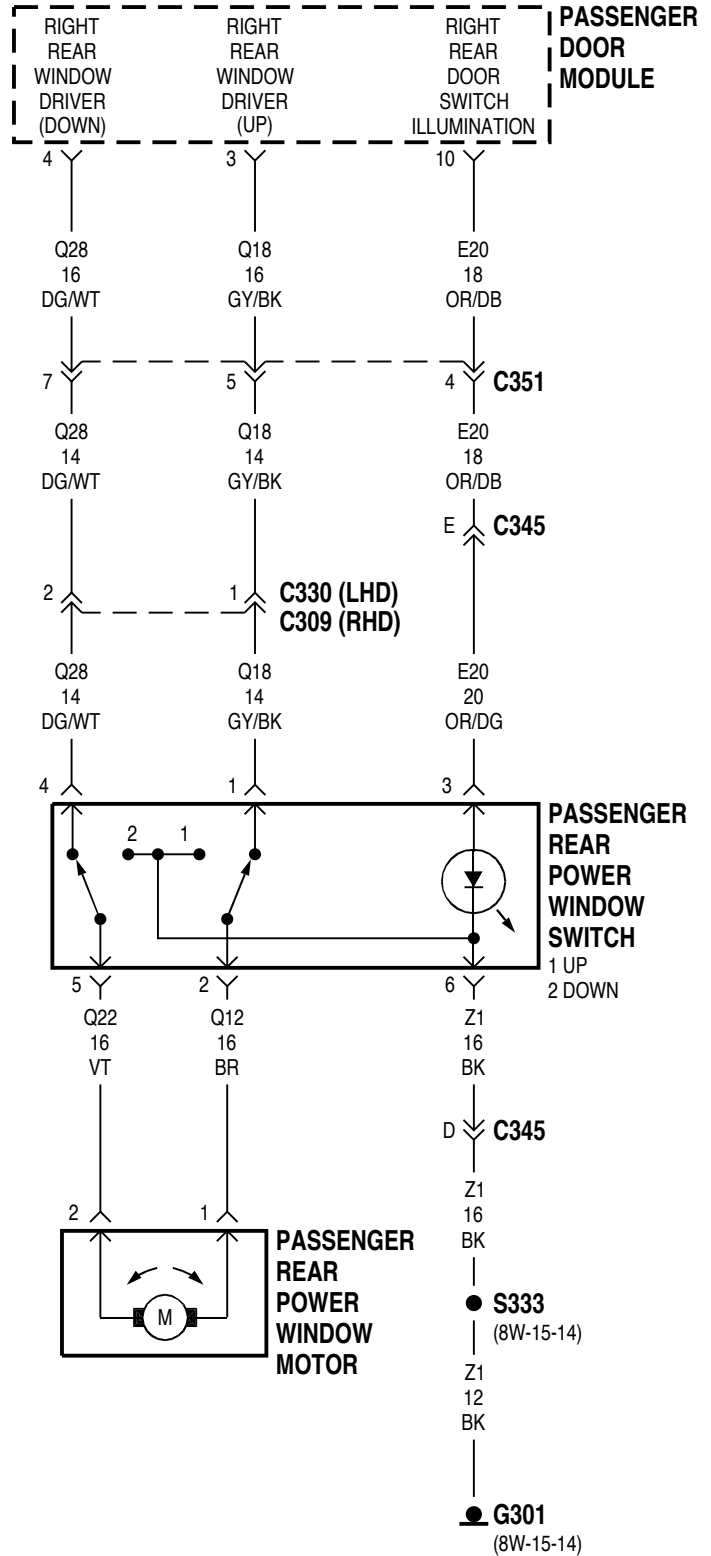
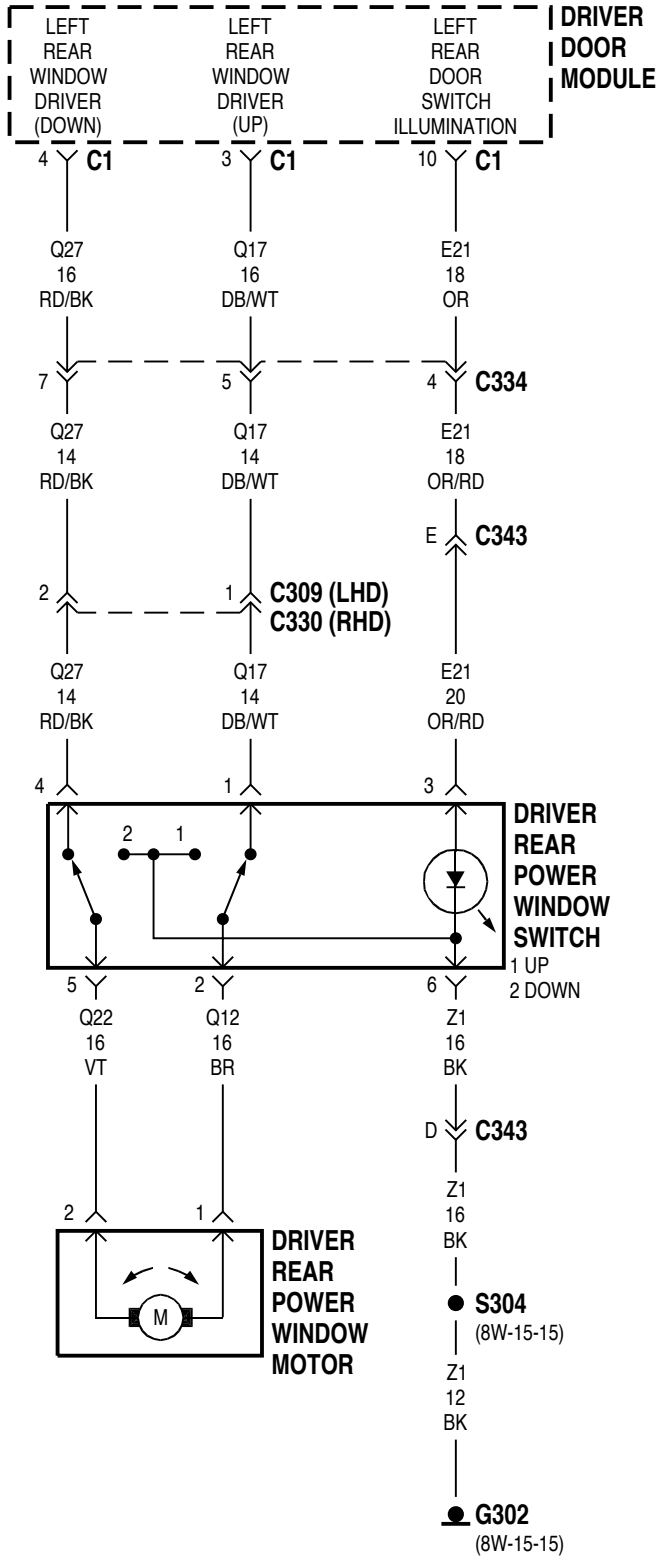


8W-60 POWER WINDOWS

Component	Page	Component	Page
Body Control Module8W-60-2, 3	G3028W-60-2, 4
Circuit Breaker 28W-60-2, 3	Junction Block8W-60-2, 3
Driver Door Module8W-60-2, 4	Passenger Door Module.8W-60-3, 4
Driver Front Power Window Motor.8W-60-2	Passenger Front Power Window Motor8W-60-3
Driver Rear Power Window Motor8W-60-4	Passenger Rear Power Window Motor8W-60-4
Driver Rear Power Window Switch.8W-60-4	Passenger Rear Power Window Switch8W-60-4
G3018W-60-3, 4		

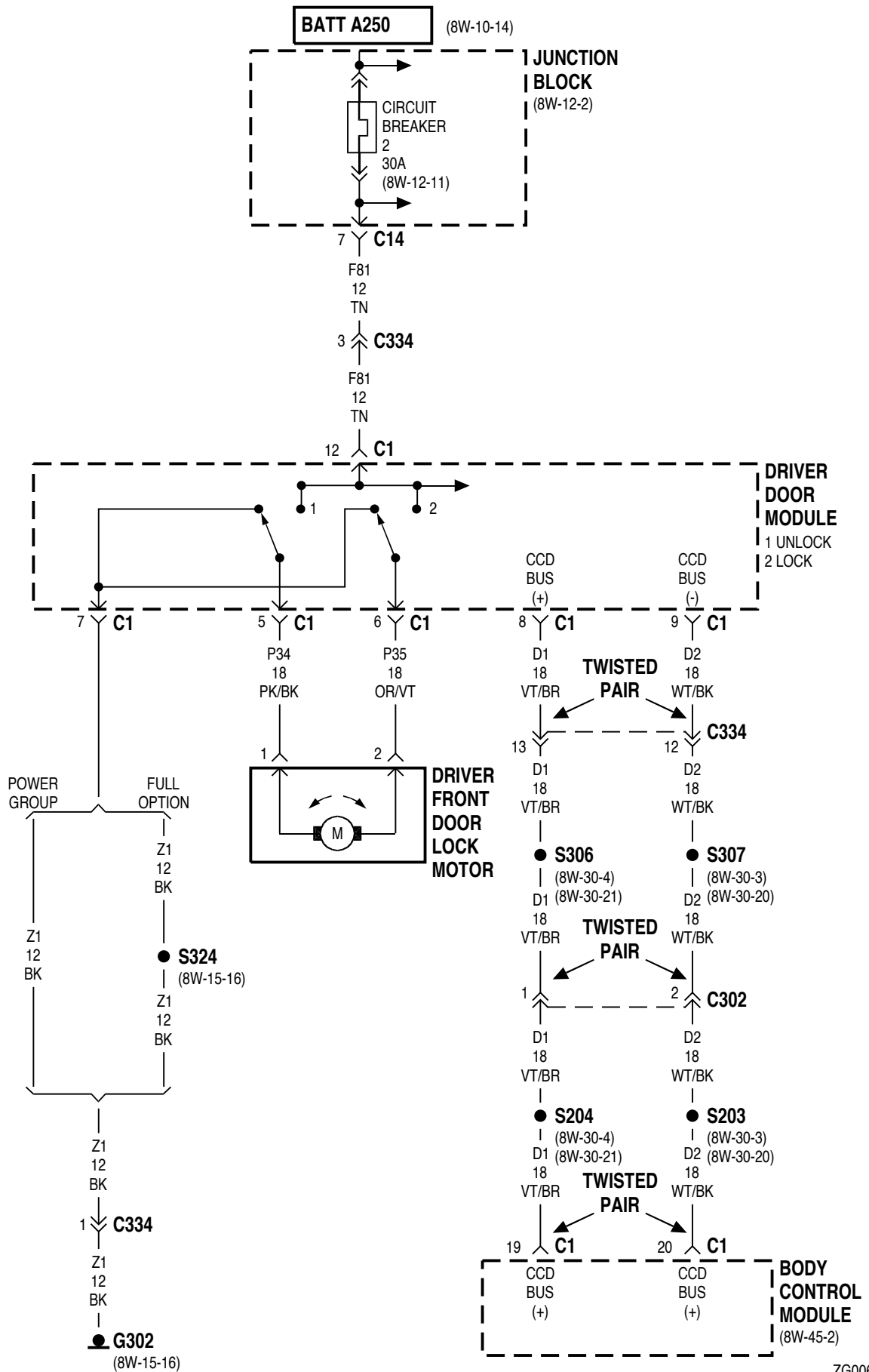


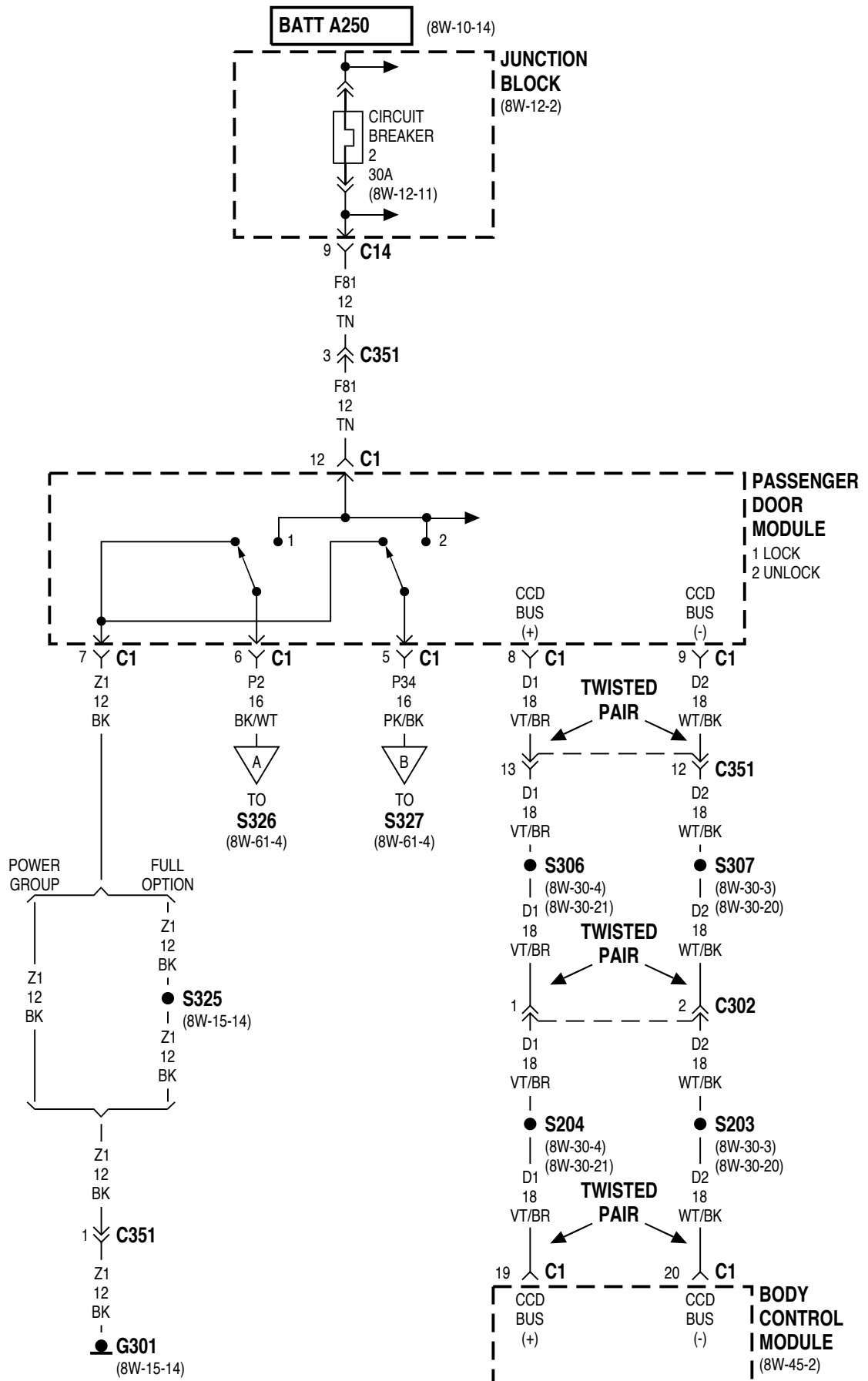


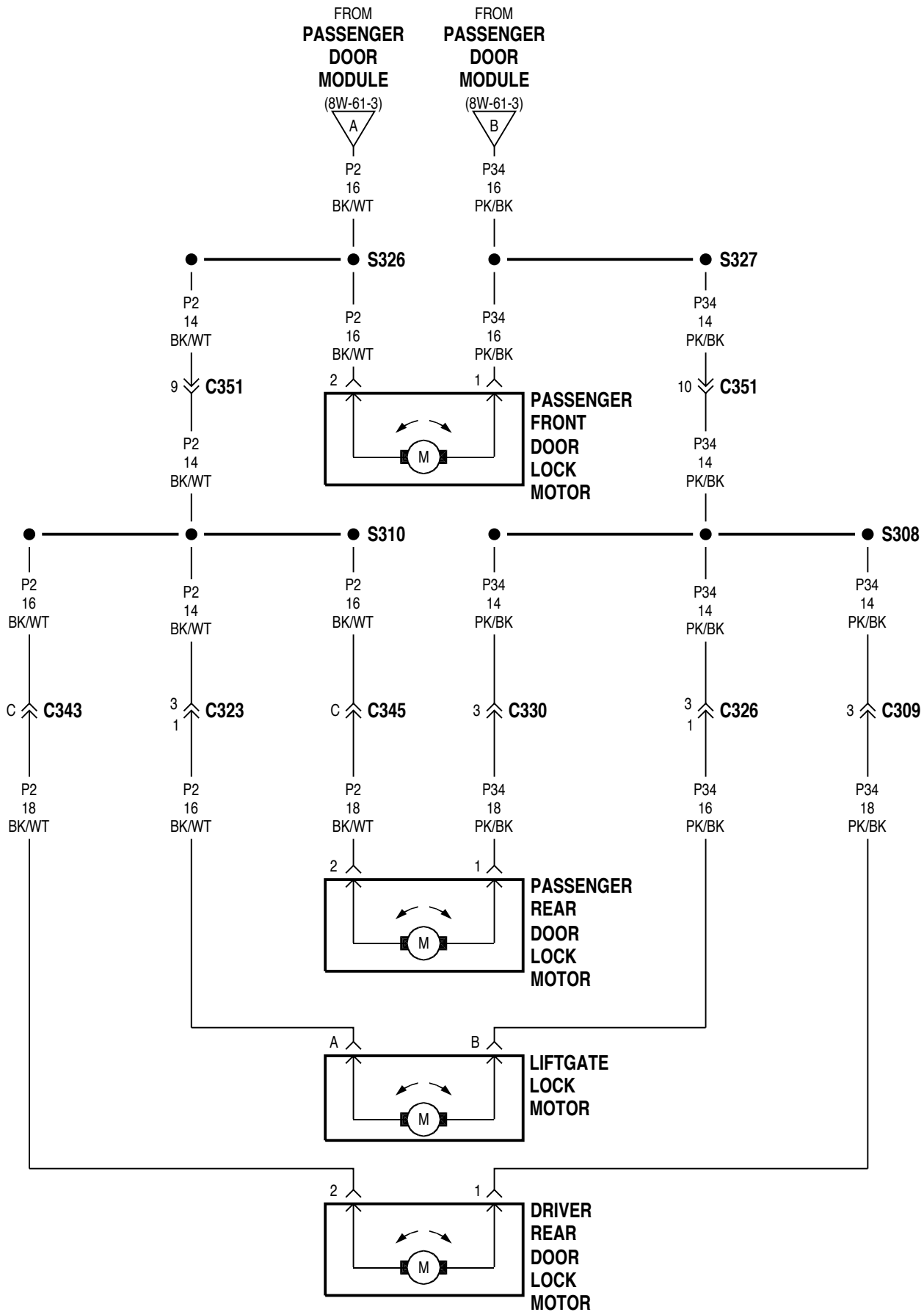


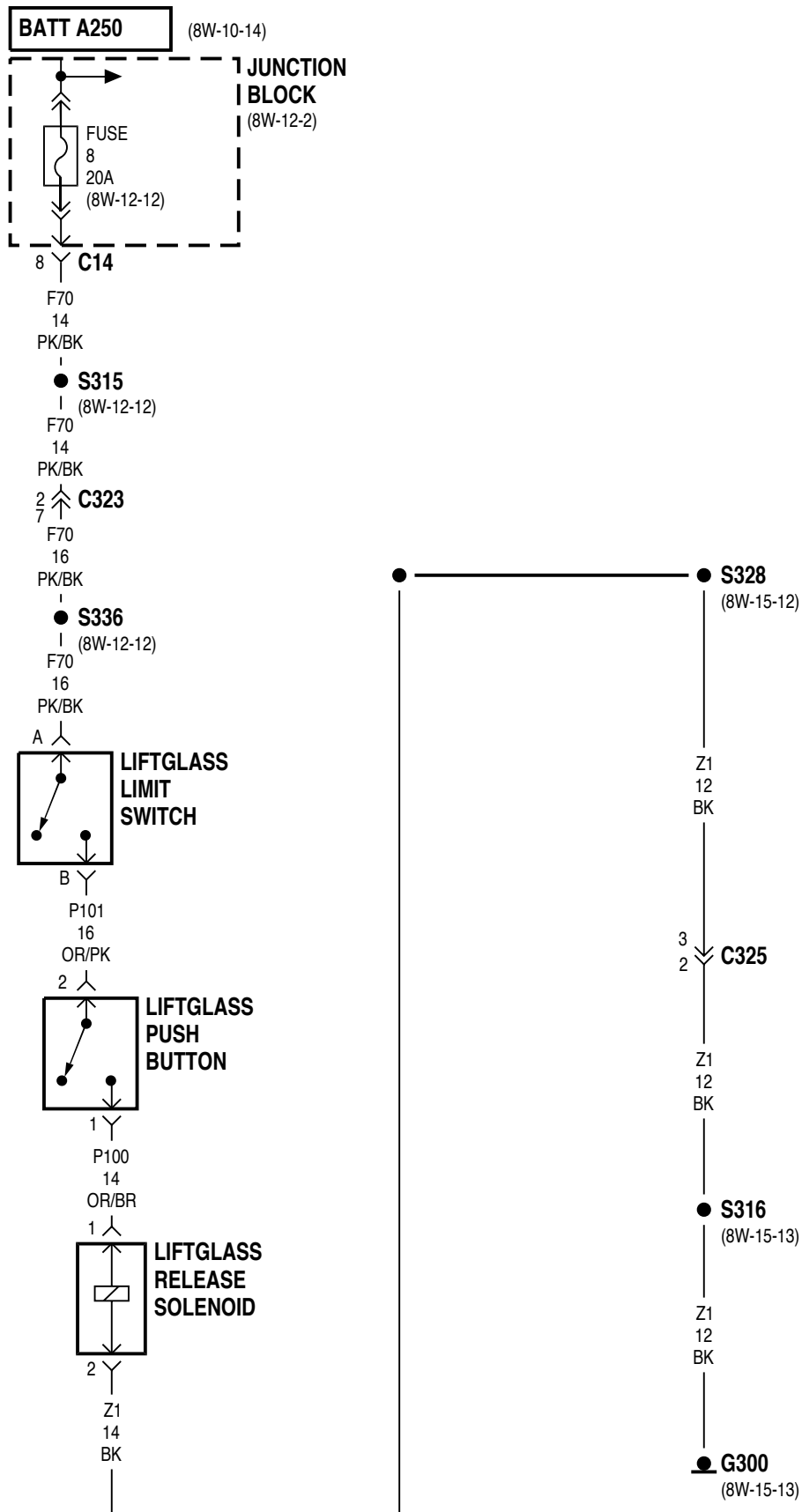
8W-61 POWER DOOR LOCKS

Component	Page	Component	Page
Body Control Module8W-61-2, 3	Junction Block8W-61-2, 3, 5
Circuit Breaker 28W-61-2, 3	Liftgate Lock Motor8W-61-4
Driver Door Module8W-61-2	Liftglass Limit Switch8W-61-5
Driver Front Door Lock Motor8W-61-2	Liftglass Push Button8W-61-5
Driver Rear Door Lock Motor8W-61-4	Liftglass Release Solenoid8W-61-5
Fuse 8 (JB)8W-61-5	Passenger Door Module8W-61-3
G3008W-61-5	Passenger Front Door Lock Motor8W-61-4
G3018W-61-3	Passenger Rear Door Lock Motor8W-61-4
G3028W-61-2		



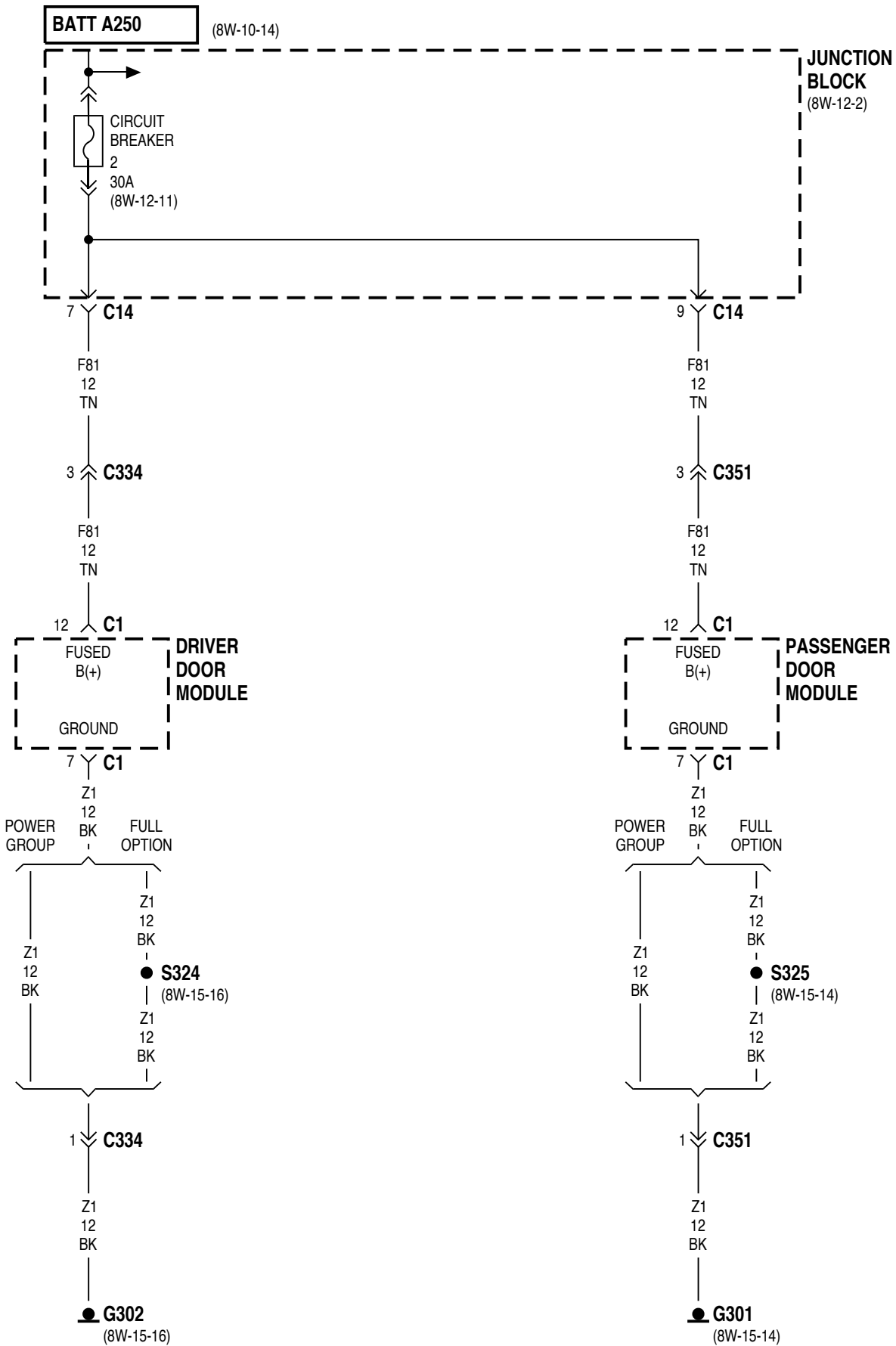


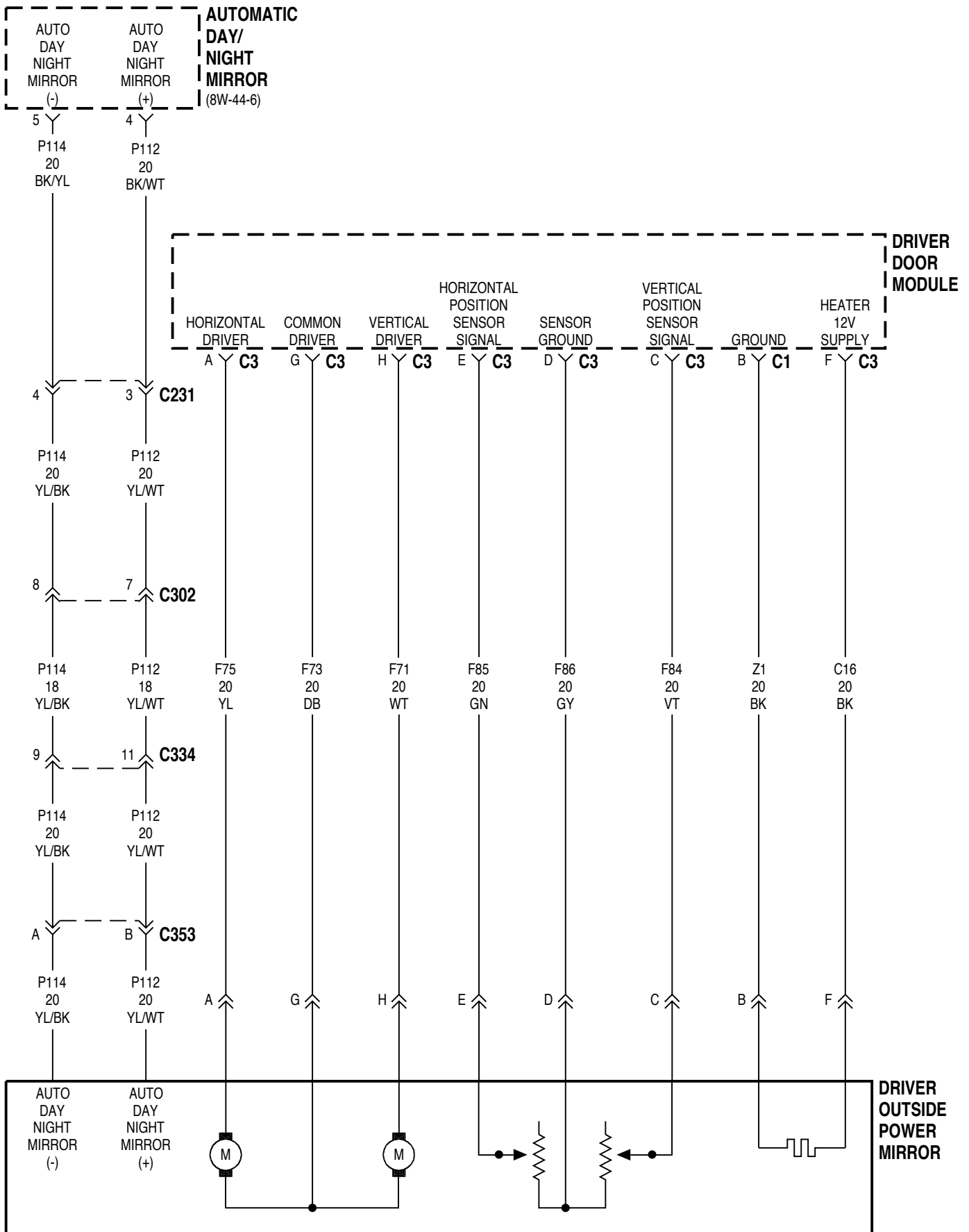


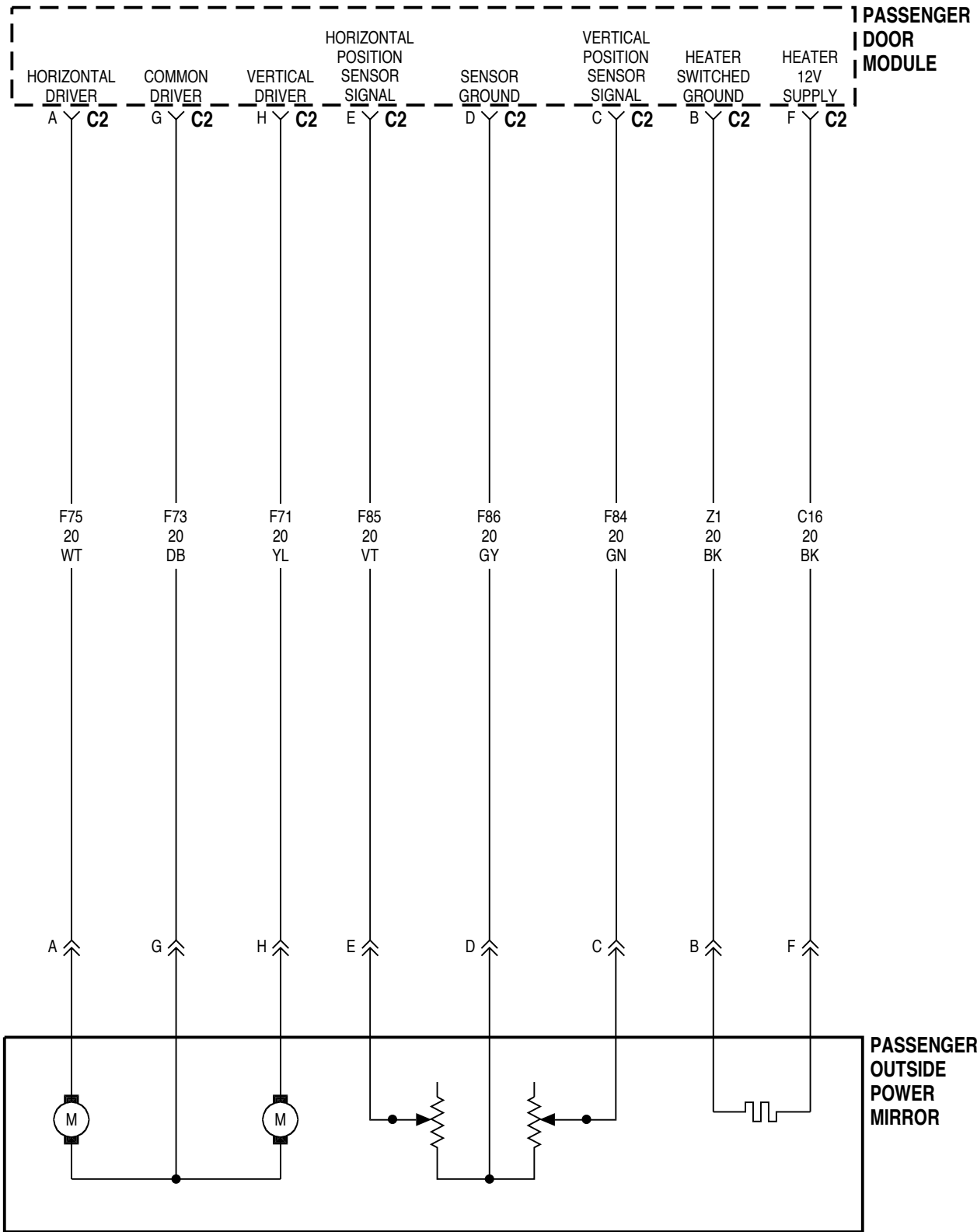


8W-62 POWER MIRRORS

Component	Page	Component	Page
Automatic Day/Night Mirror	8W-62-3	G302	8W-62-2
Circuit Breaker 2	8W-62-2	Junction Block	8W-62-2
Driver Door Module	8W-62-2, 3	Passenger Door Module	8W-62-2, 4
Driver Outside Power Mirror	8W-62-3	Passenger Outside Power Mirror	8W-62-4
G301	8W-62-2		

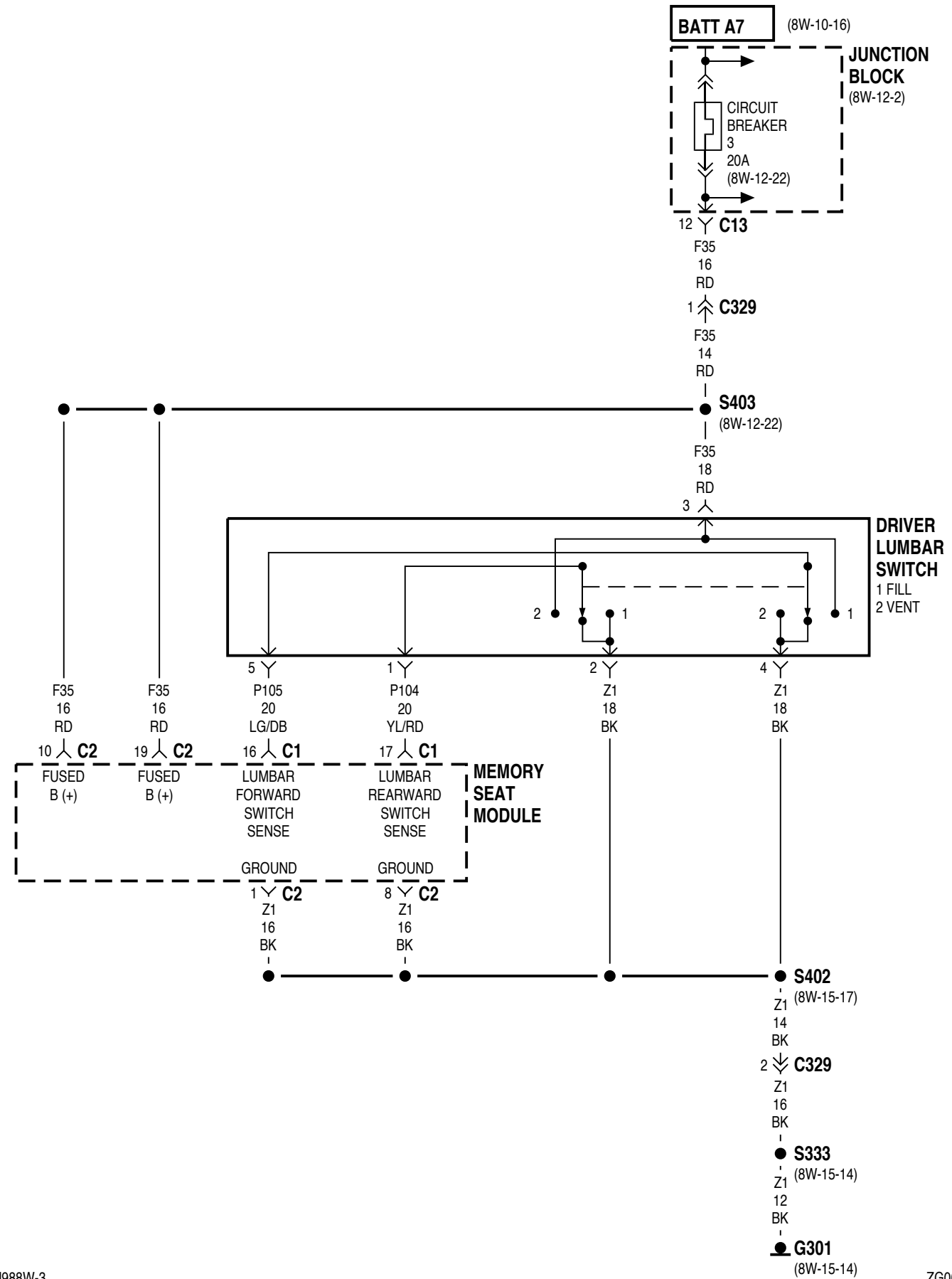


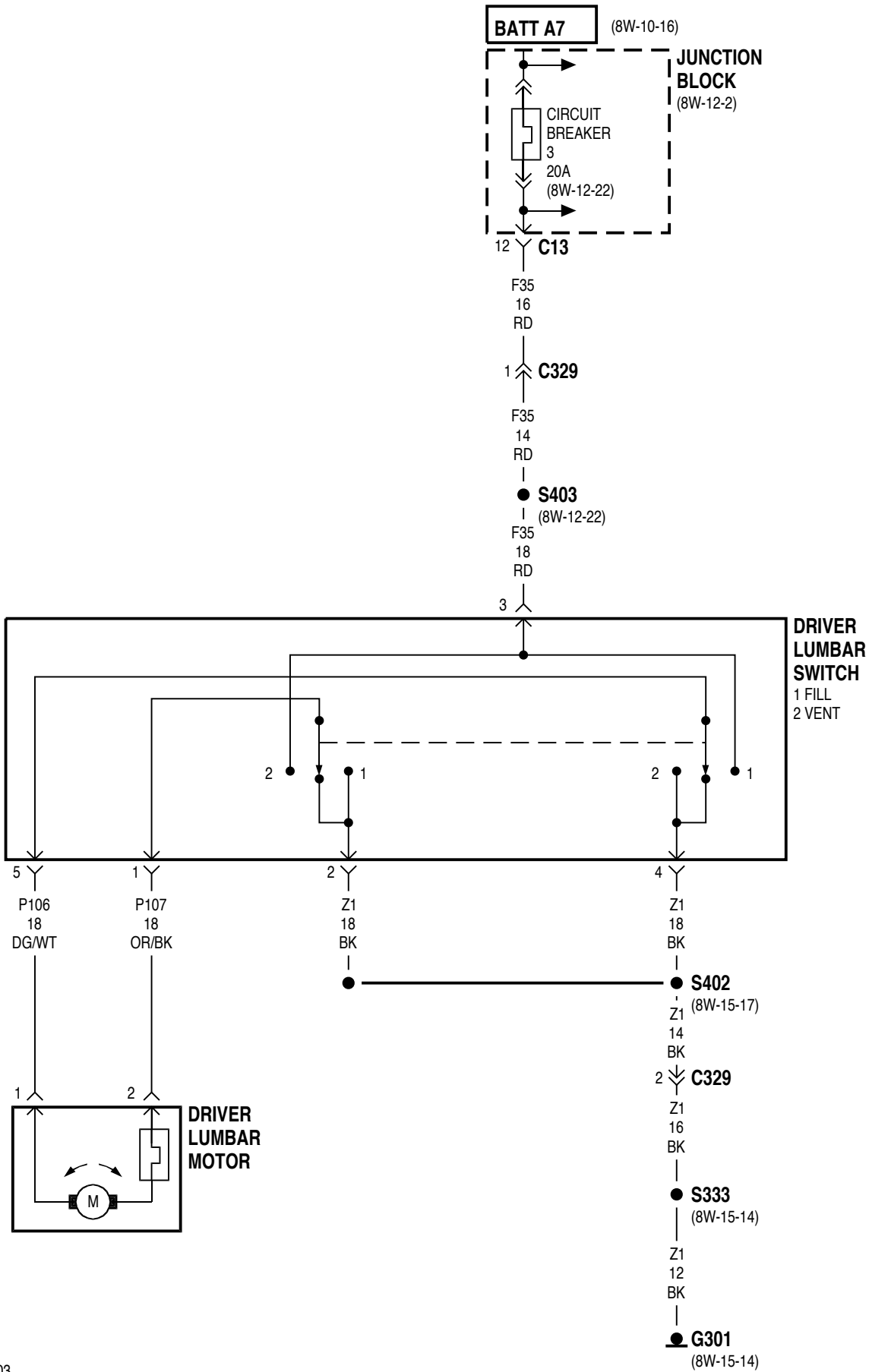


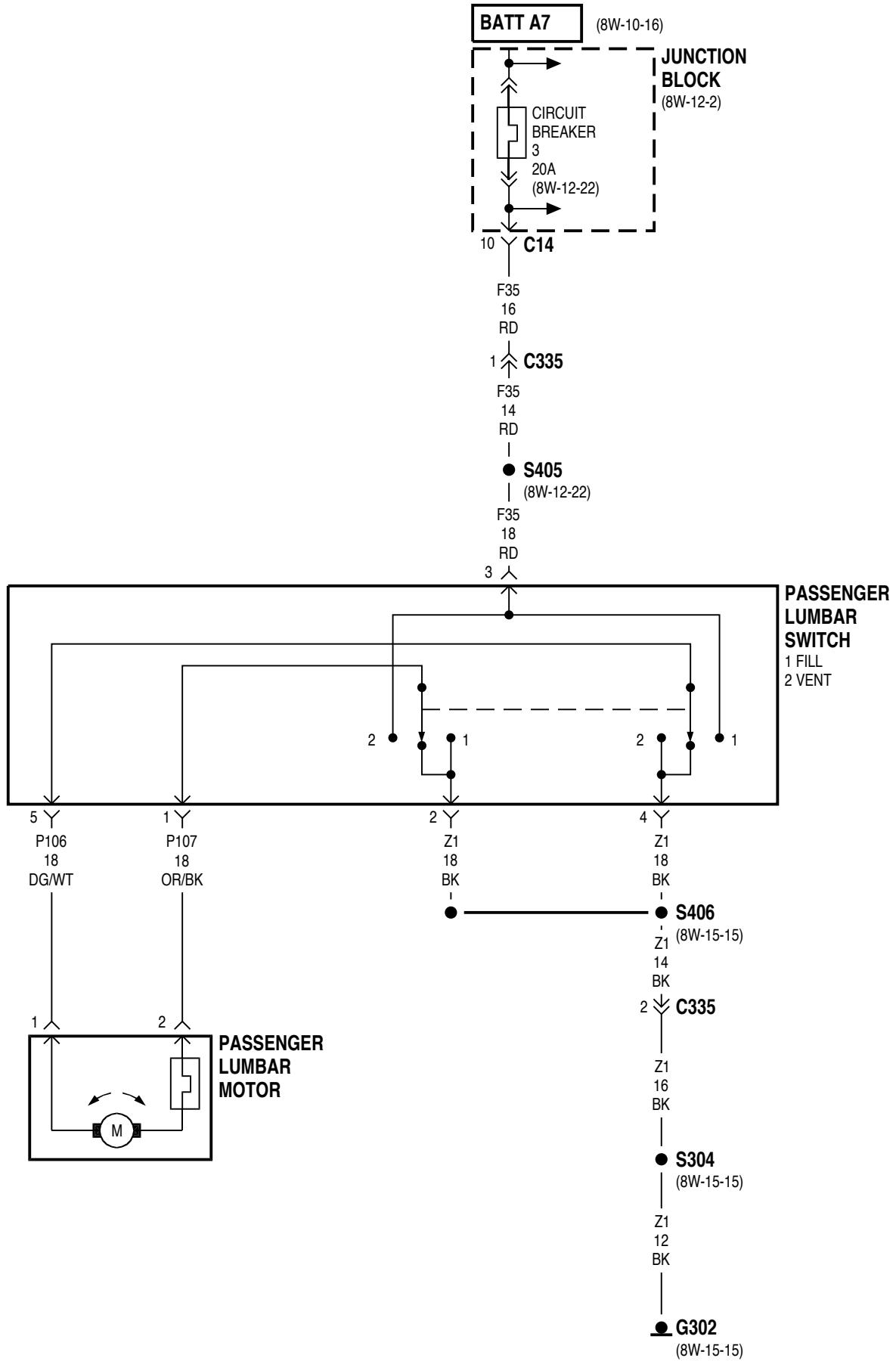


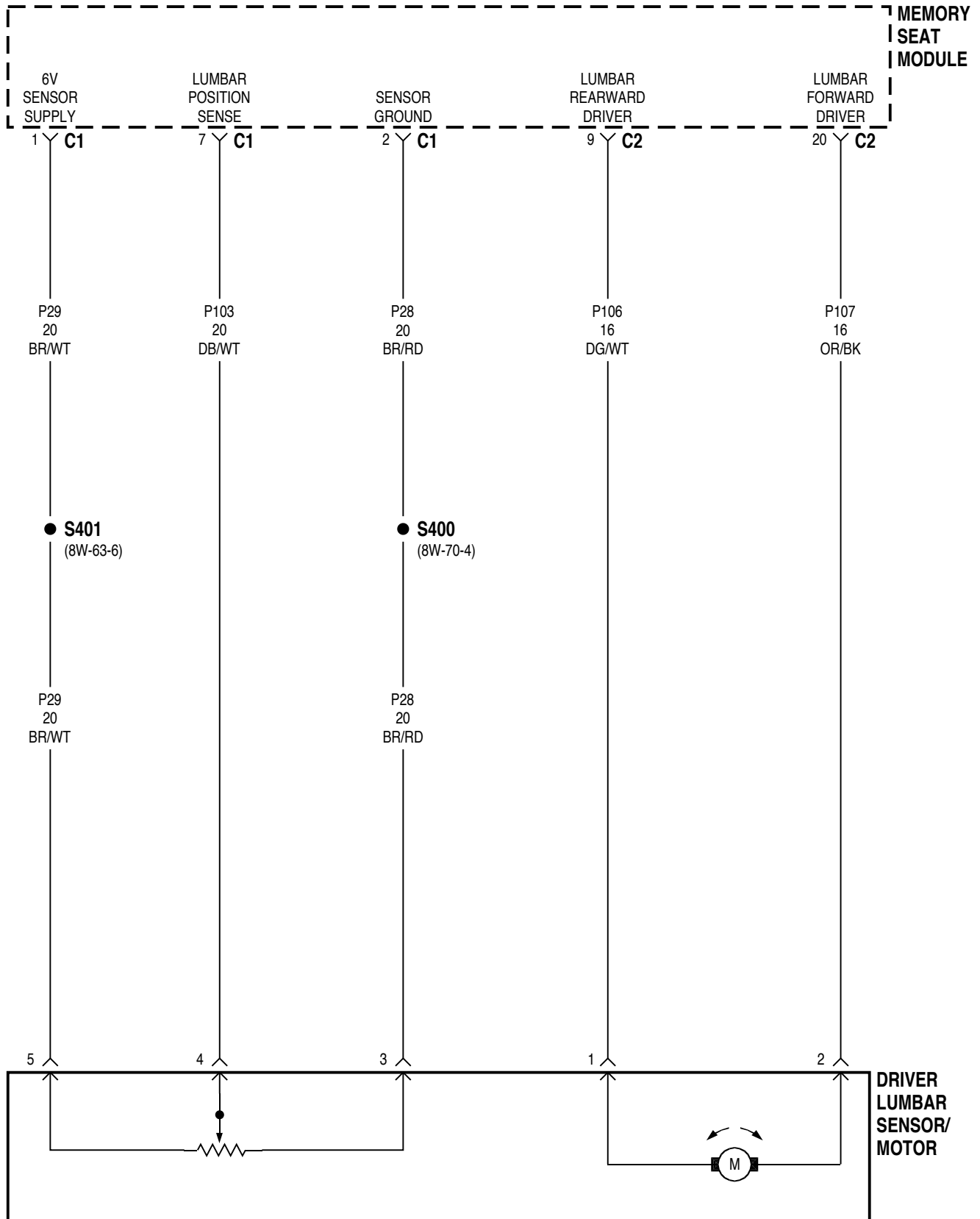
8W-63 POWER SEAT

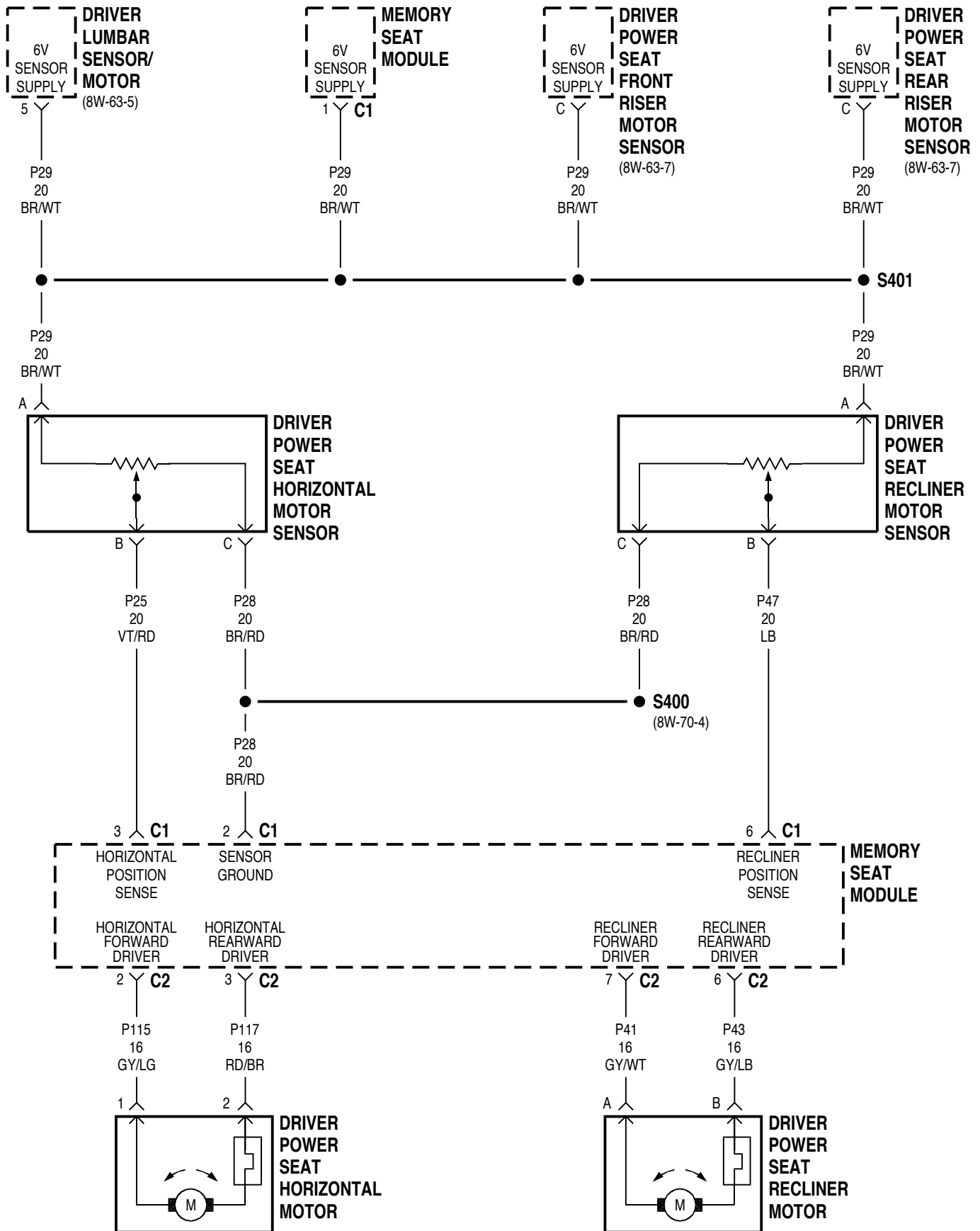
Component	Page	Component	Page
Circuit Breaker 38W-63-2, 3, 4, 8, 9, 10, 13, 14	Fuse 12 (JB)8W-63-13, 14
Driver Door Module8W-63-15	G3018W-63-2, 3, 8, 10, 11
Driver Heated Seat Back8W-63-11	G3028W-63-4, 9, 12
Driver Heated Seat Cushion8W-63-11	G3038W-63-13, 14
Driver Lumbar Motor8W-63-3	Heated Seat Switch8W-63-11, 12, 13, 14
Driver Lumbar Sensor/Motor8W-63-5, 6	Junction Block8W-63-2, 3, 4, 8, 9, 10, 13, 14
Driver Lumbar Switch8W-63-2, 3	Memory Seat Module8W-63-2, 5, 6, 7, 8, 15
Driver Power Seat Front Riser Motor8W-63-7, 10	Memory Set Switch8W-63-15
Driver Power Seat Front Riser Motor Sensor8W-63-6, 7	Passenger Door Module8W-63-15
Driver Power Seat Horizontal Motor8W-63-6, 10	Passenger Heated Seat Back8W-63-12
Driver Power Seat Horizontal Motor Sensor8W-63-6	Passenger Heated Seat Cushion8W-63-12
Driver Power Seat Rear Riser Motor8W-63-7, 10	Passenger Lumbar Motor8W-63-4
Driver Power Seat Rear Riser Motor Sensor8W-63-6, 7	Passenger Lumbar Switch8W-63-4
Driver Power Seat Recliner Motor8W-63-6, 10	Passenger Power Seat Front Riser Motor8W-63-9
Driver Power Seat Recliner Motor Sensor8W-63-6	Passenger Power Seat Horizontal Motor8W-63-9
Driver Power Seat Switch8W-63-8, 10	Passenger Power Seat Rear Riser Motor8W-63-9
Driver Seat Heater Control Module8W-63-11, 14	Passenger Power Seat Recliner Motor8W-63-9
		Passenger Power Seat Switch8W-63-9
		Passenger Seat Heater Control Module8W-63-12, 13

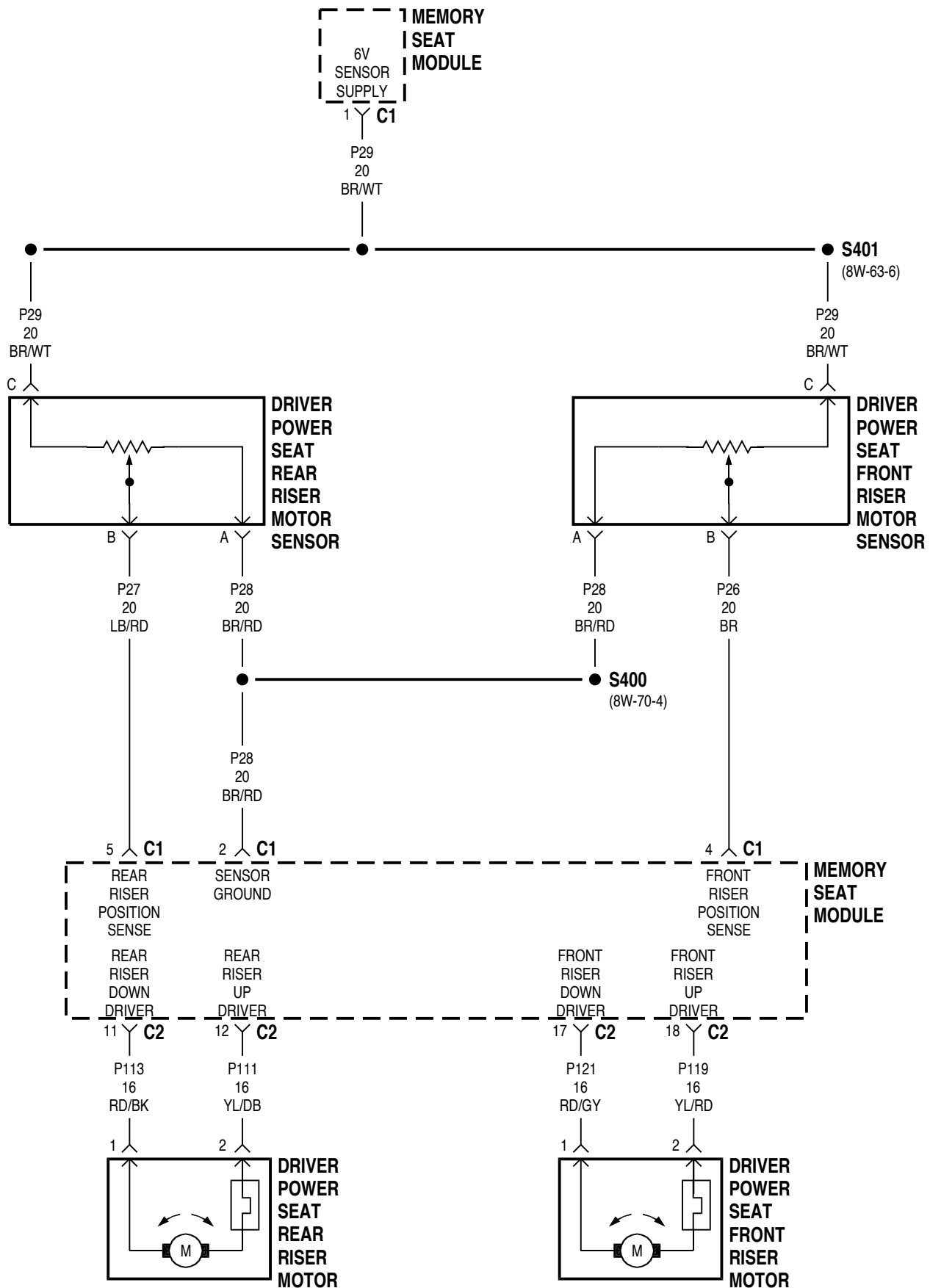


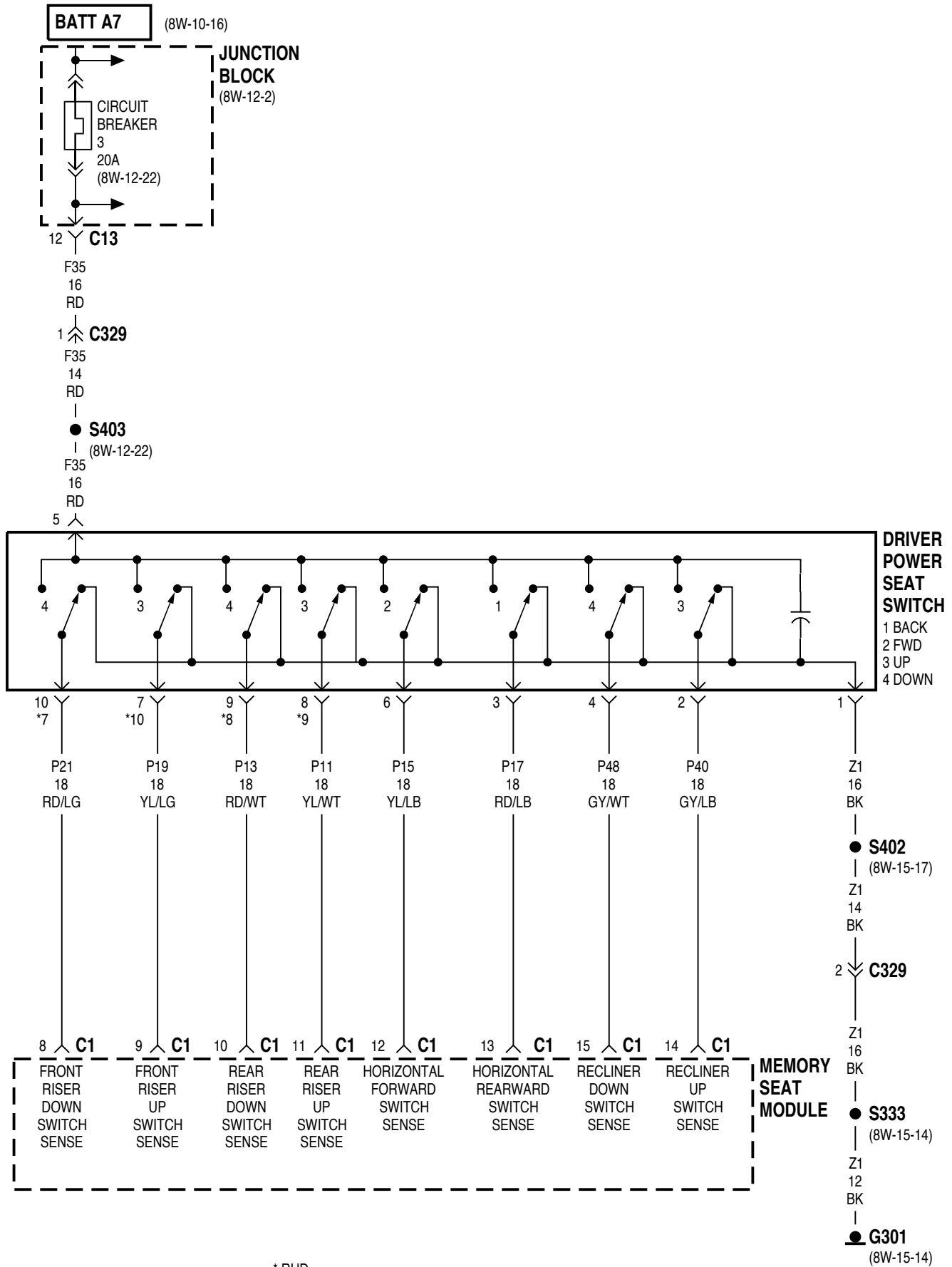




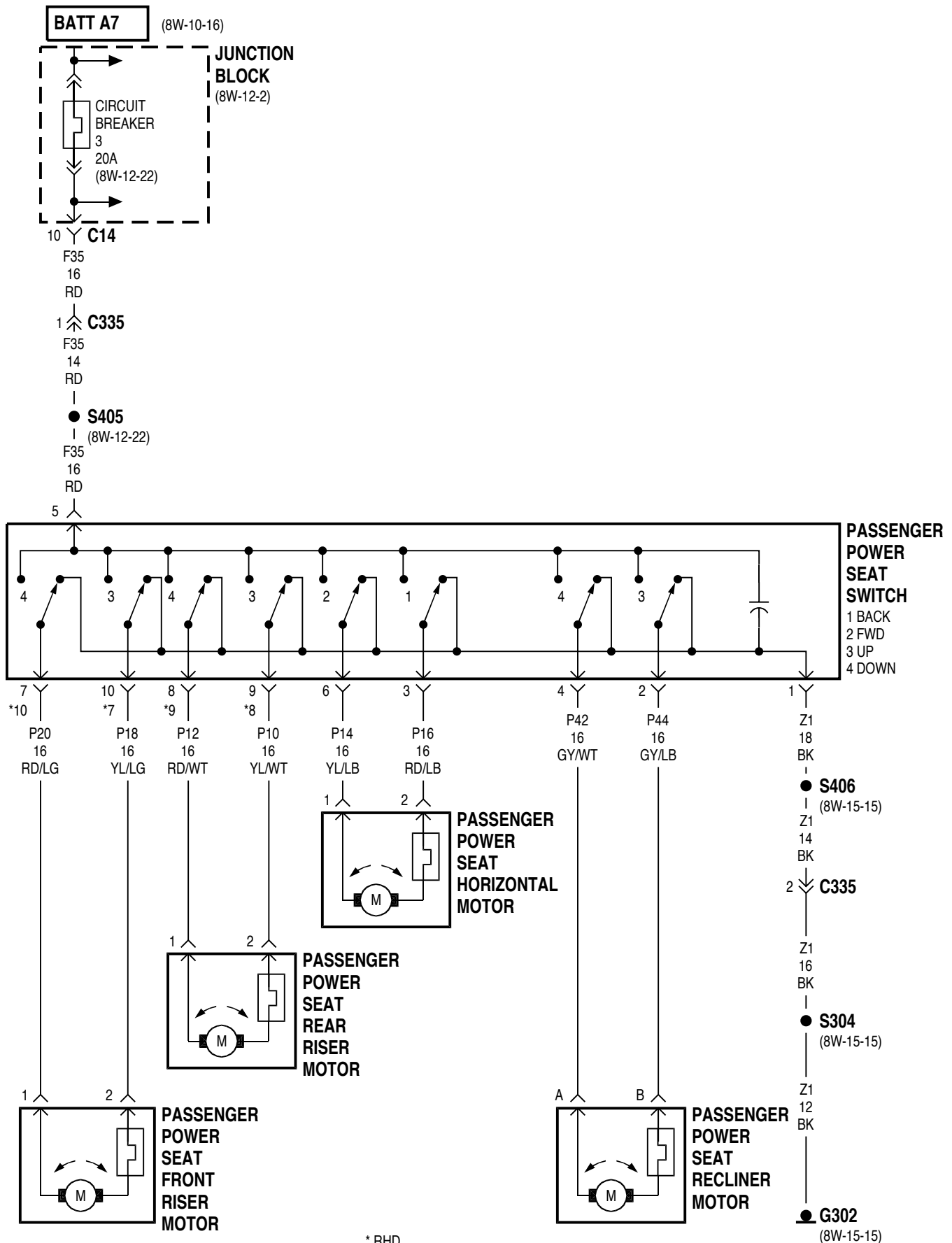




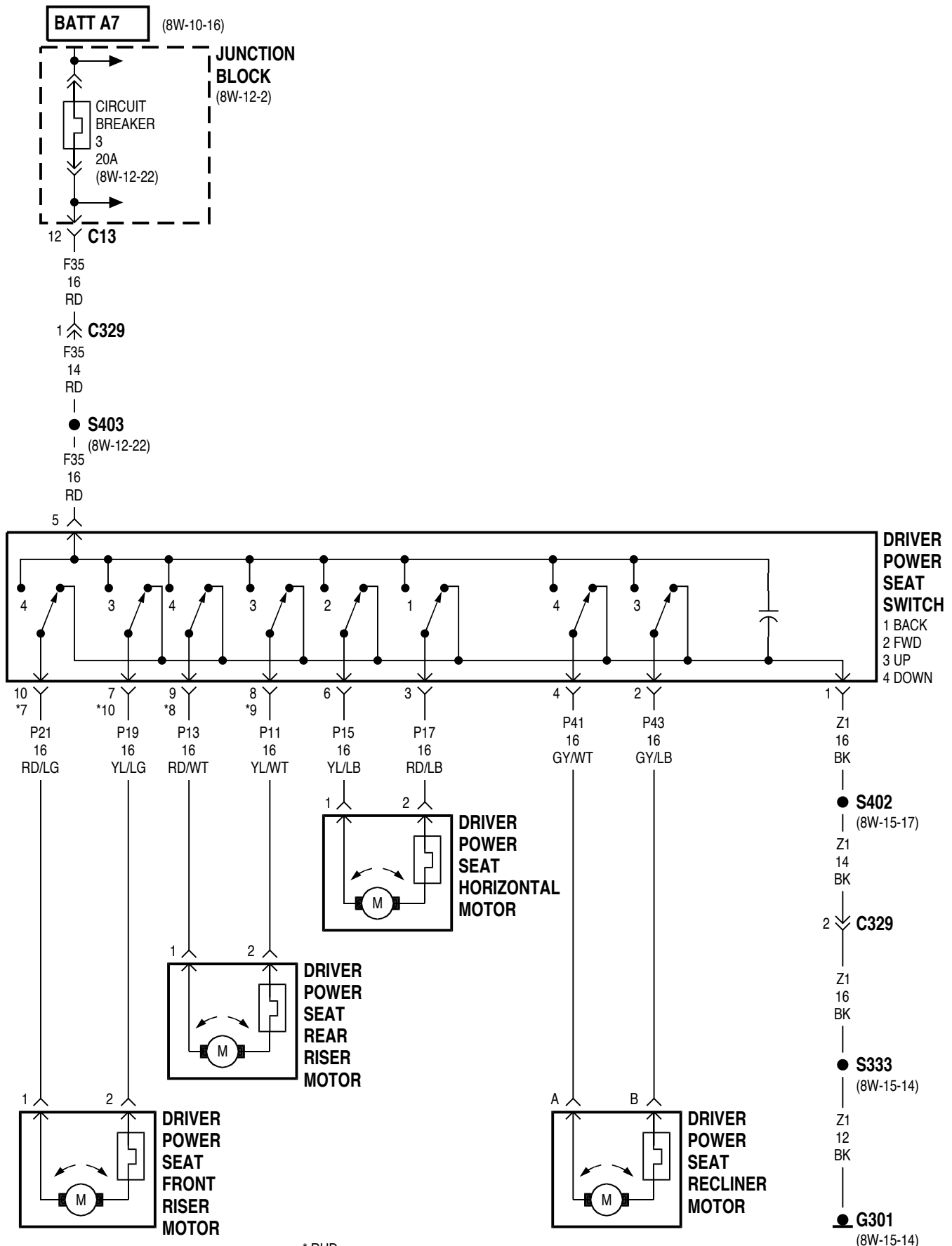




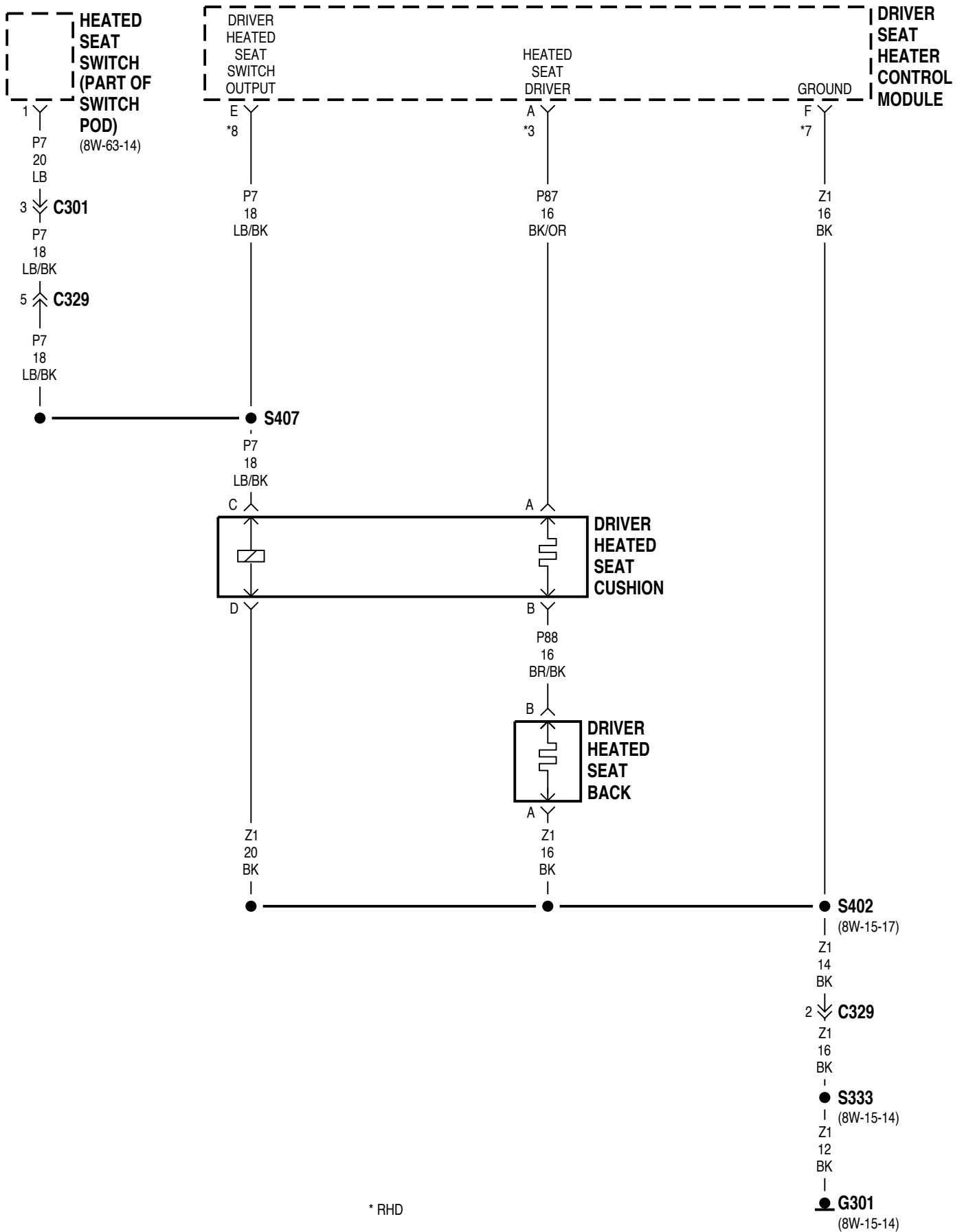
* RHD



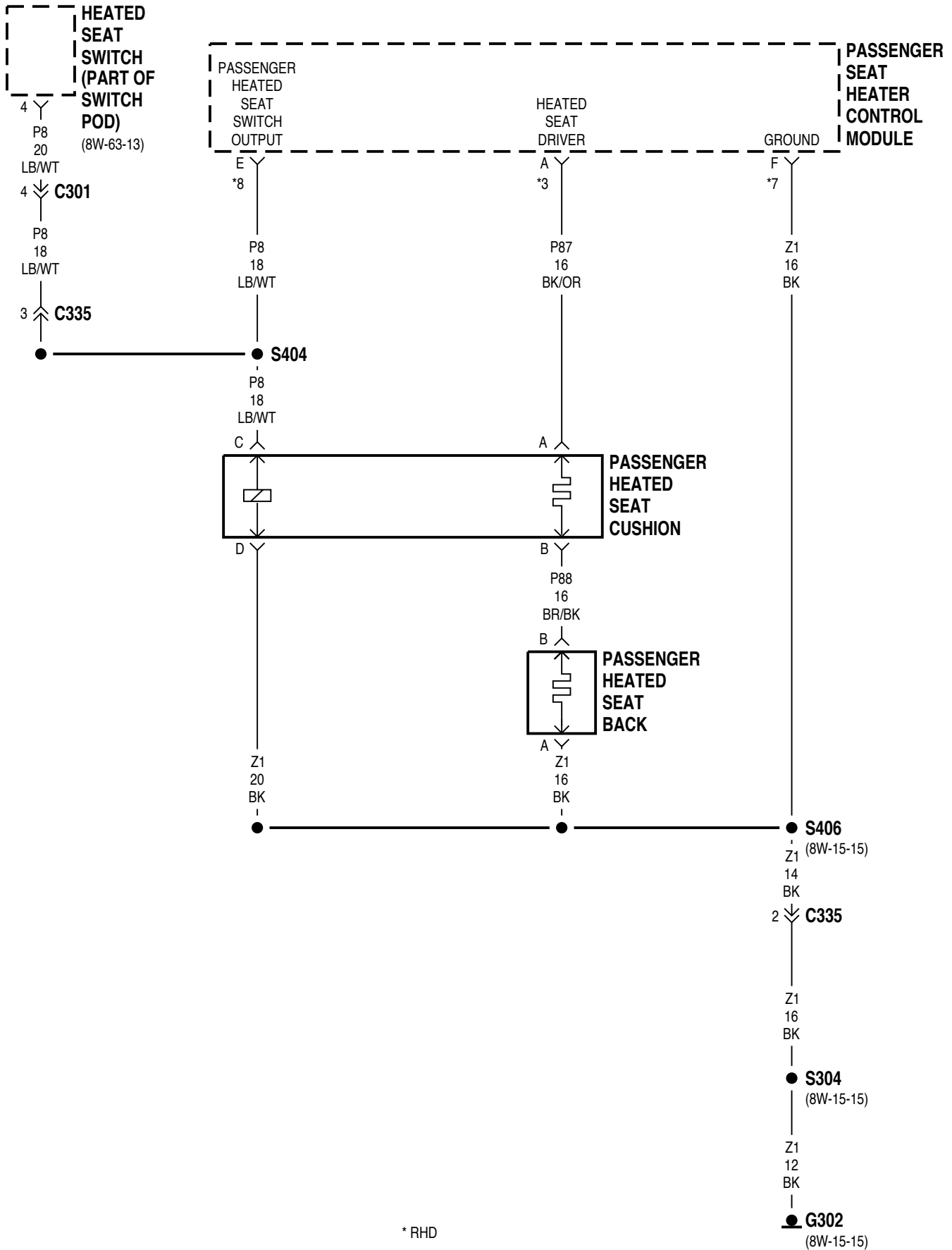
* RHD



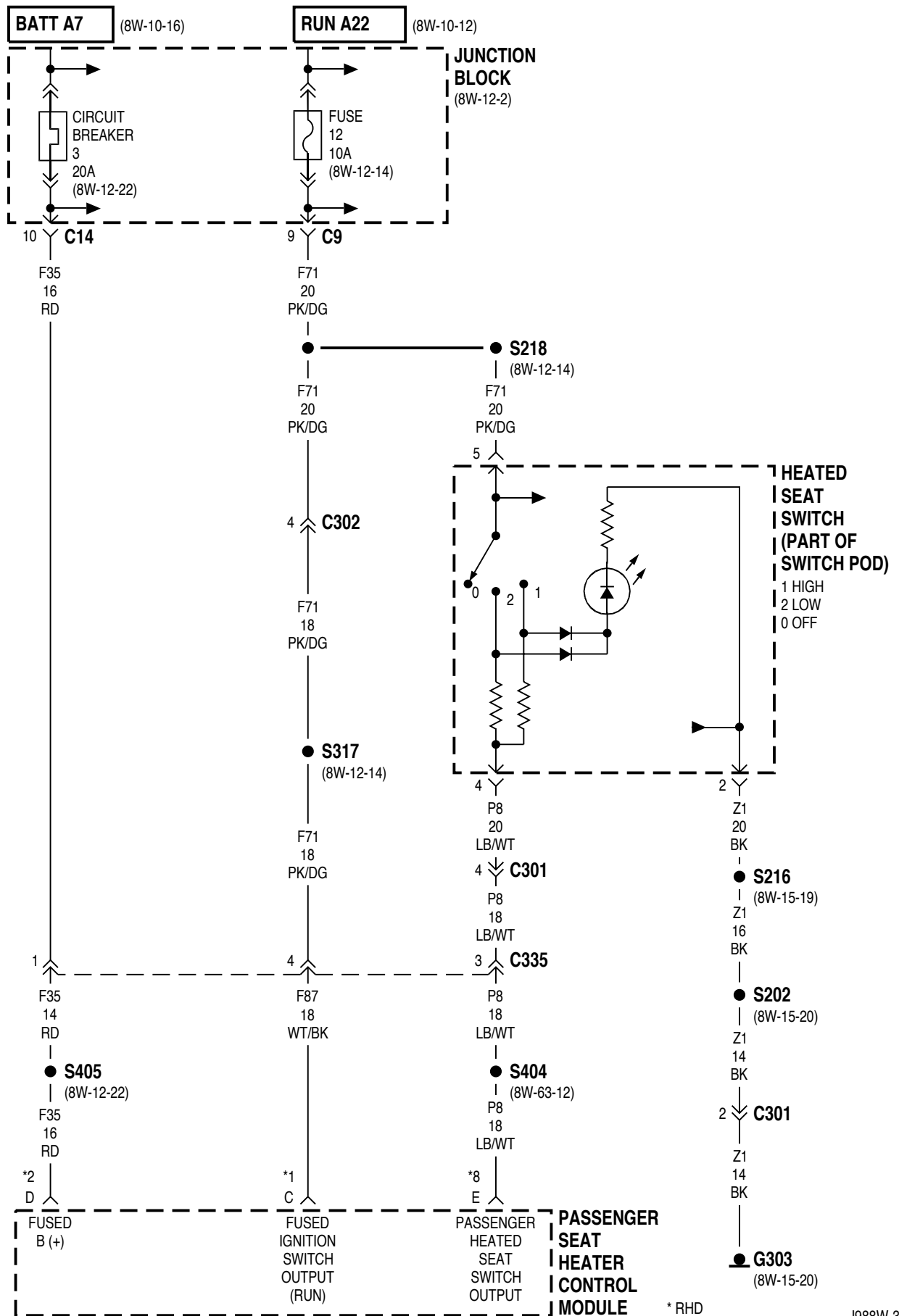
* RHD

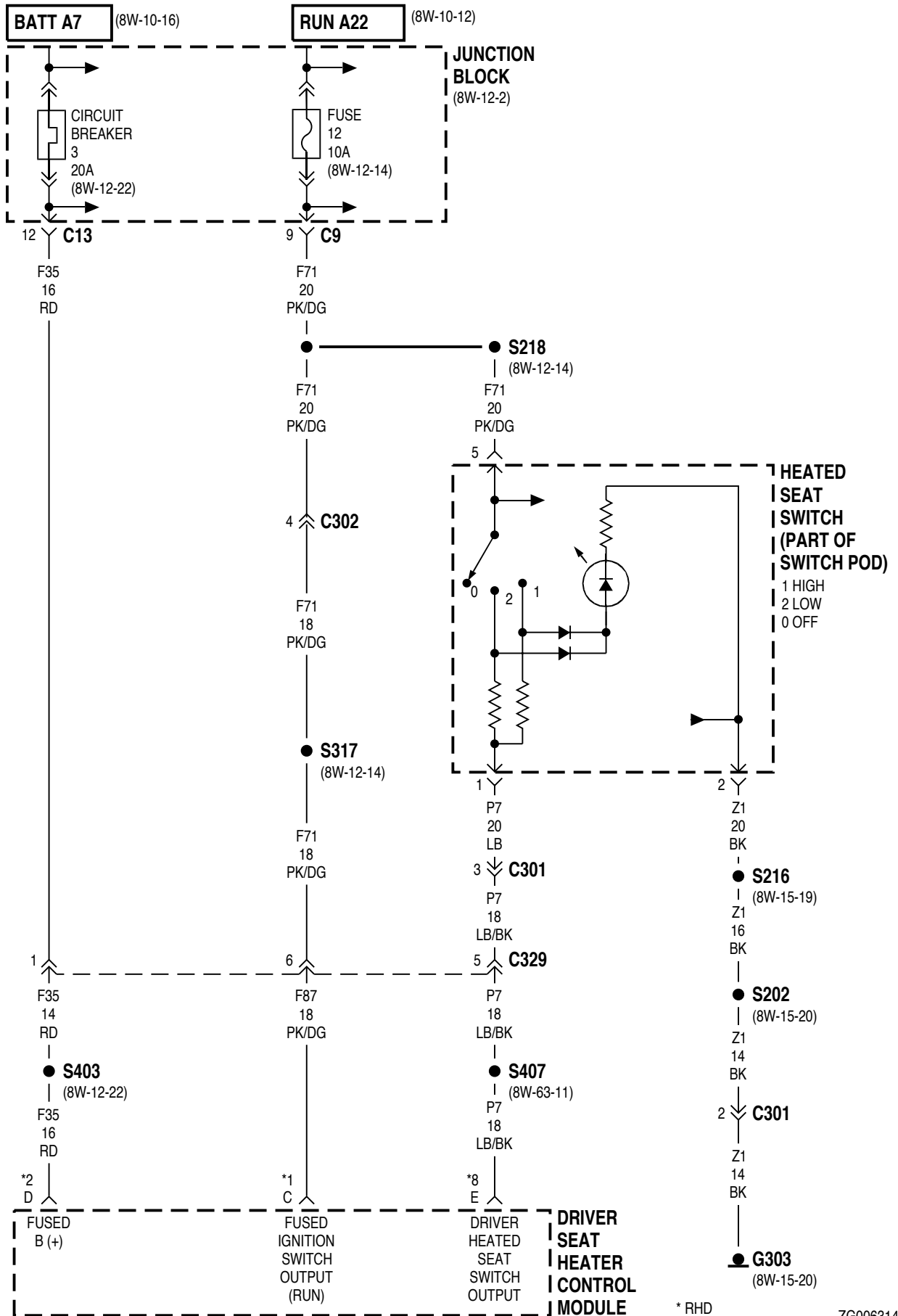


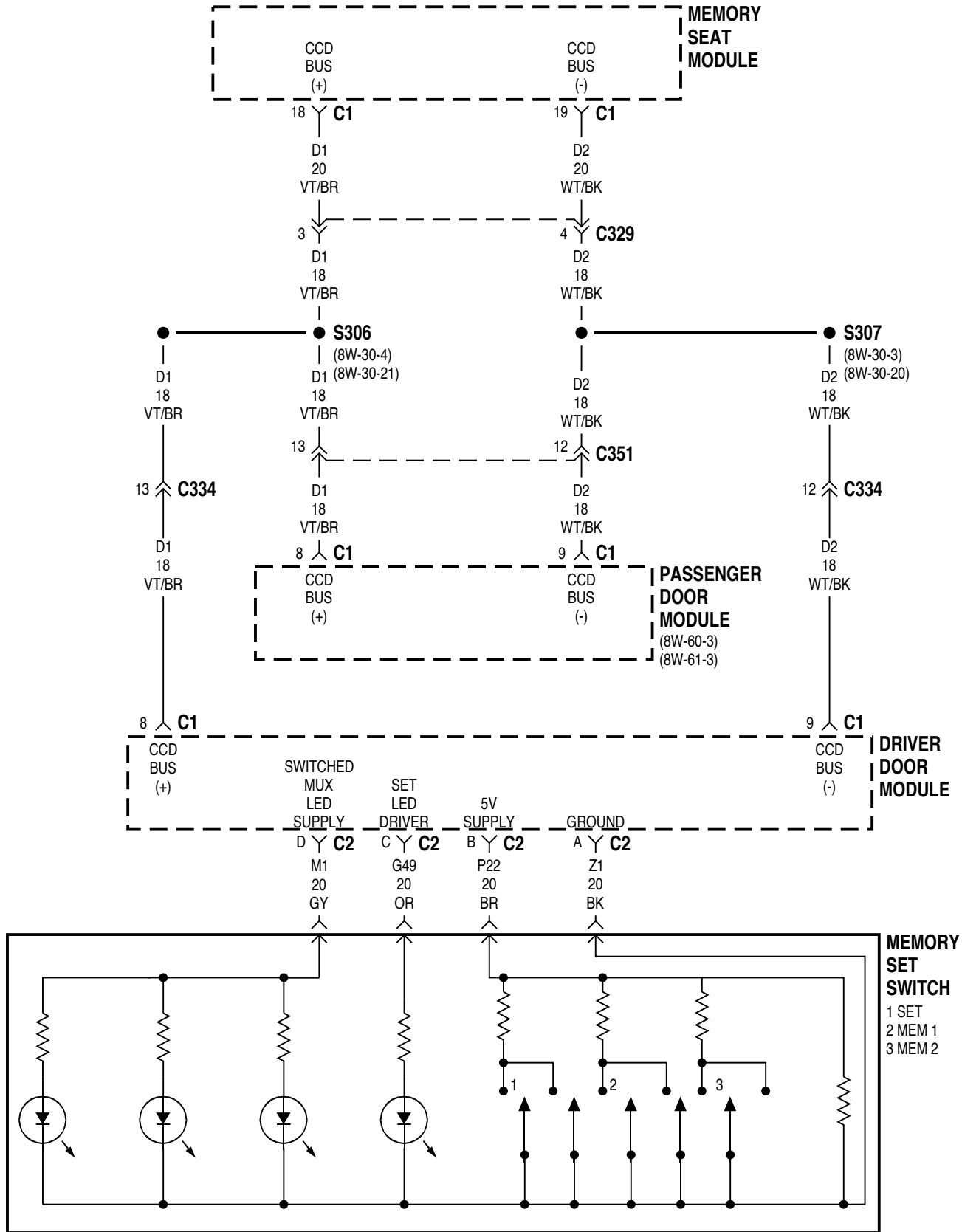
* RHD



* RHD

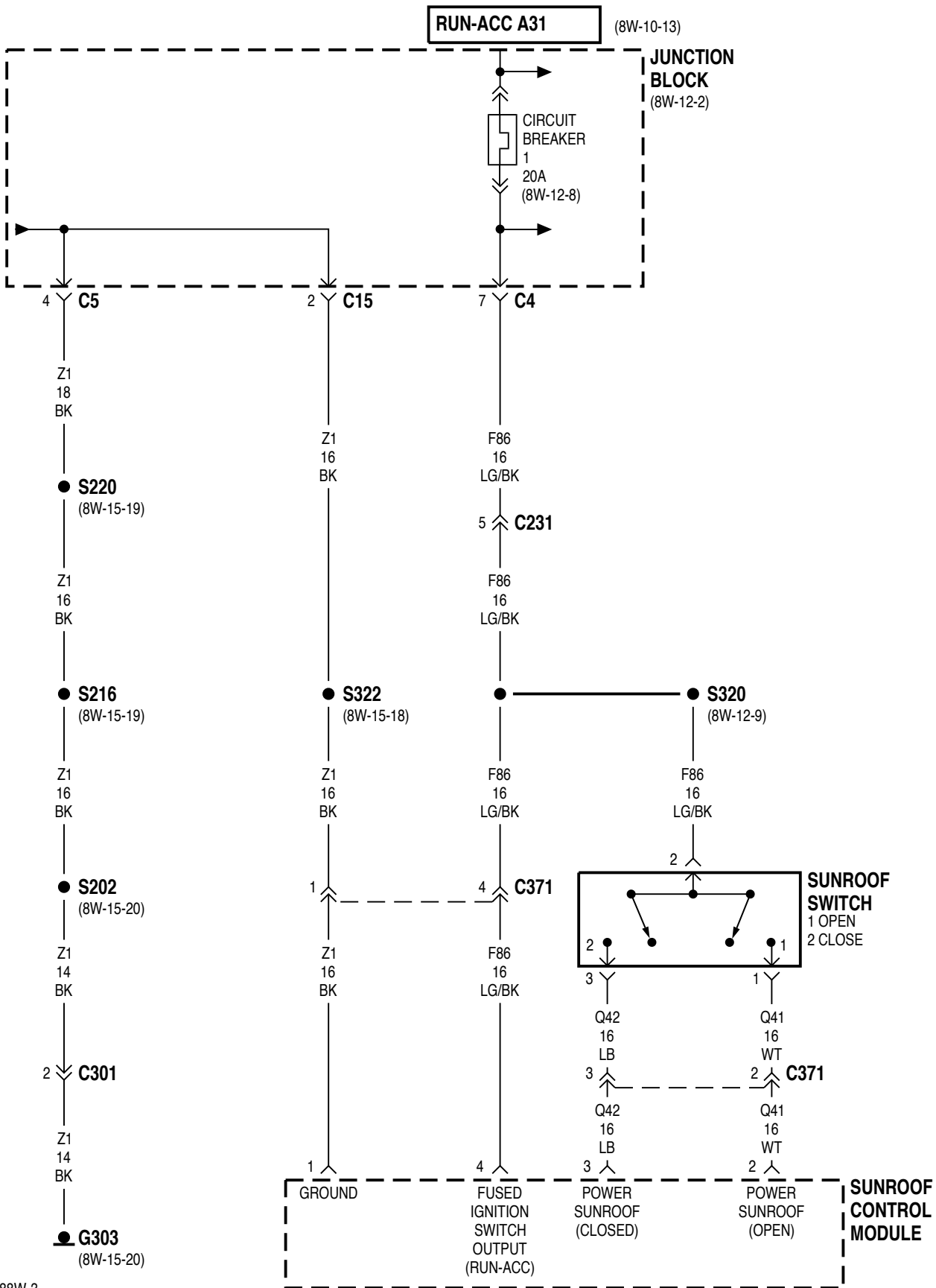


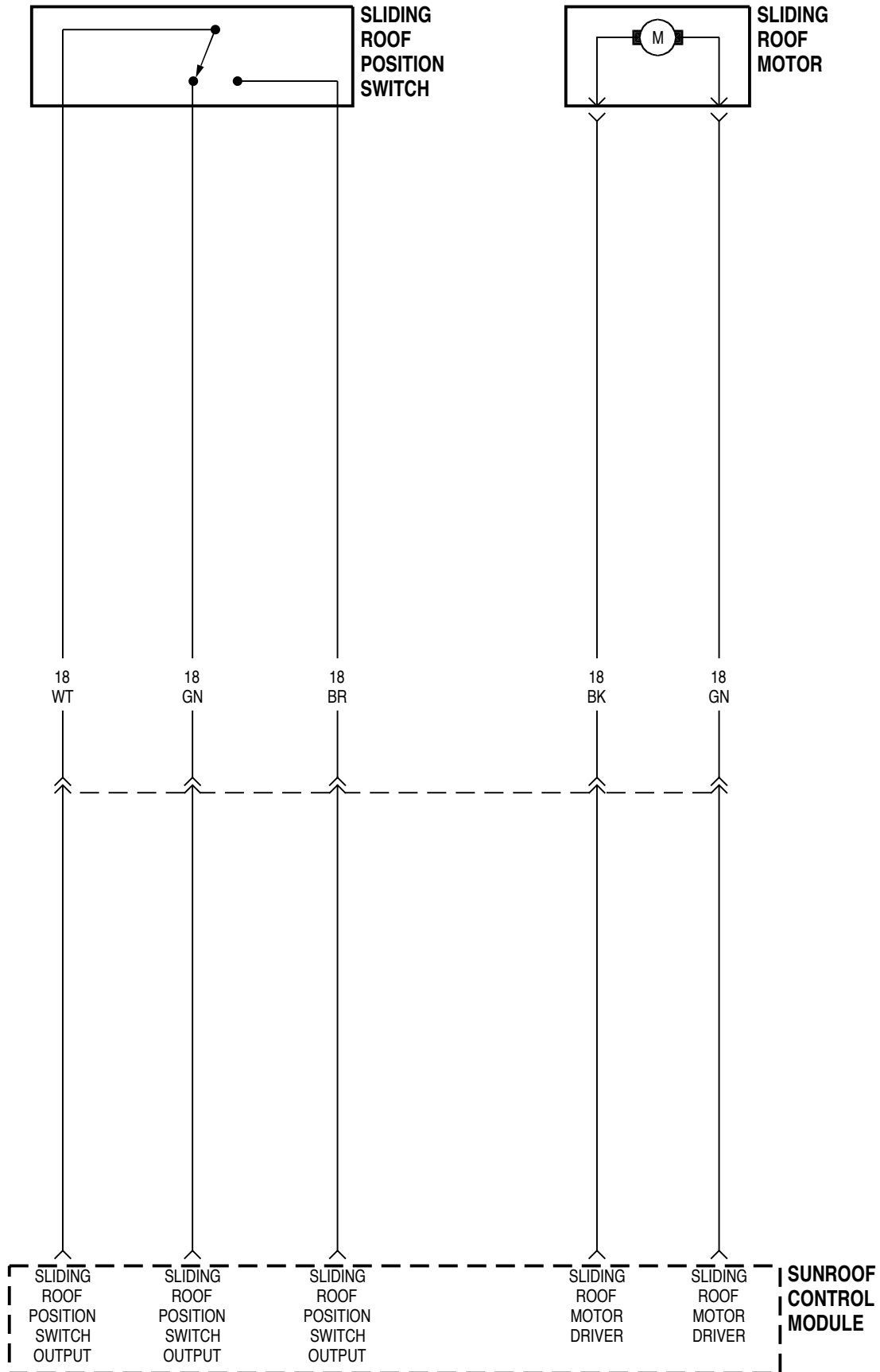




8W-64 POWER SUNROOF

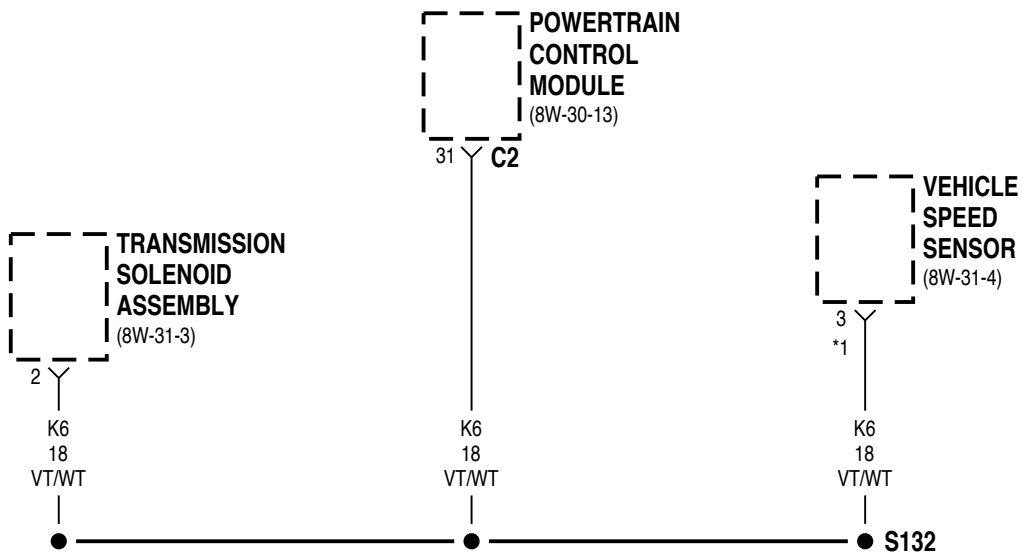
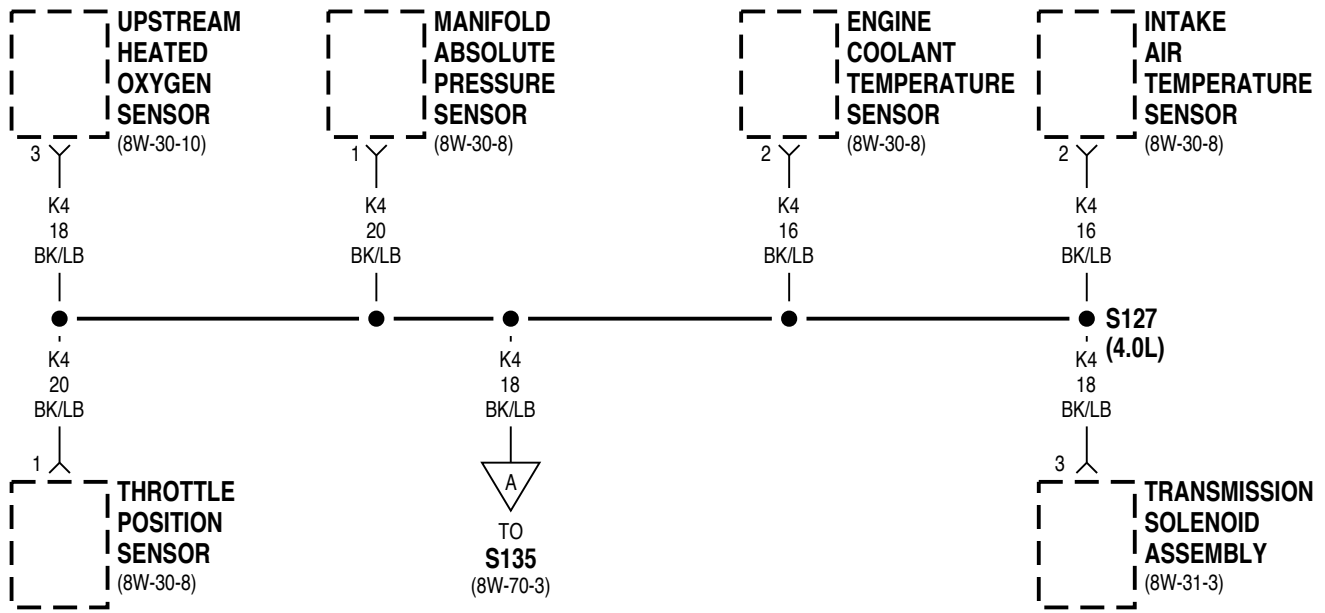
Component	Page	Component	Page
Circuit Breaker 1	8W-64-2	Sliding Roof Position Switch	8W-64-3
G303	8W-64-2	Sunroof Control Module	8W-64-2, 3
Junction Block	8W-64-2	Sunroof Switch	8W-64-2
Sliding Roof Motor	8W-64-3		



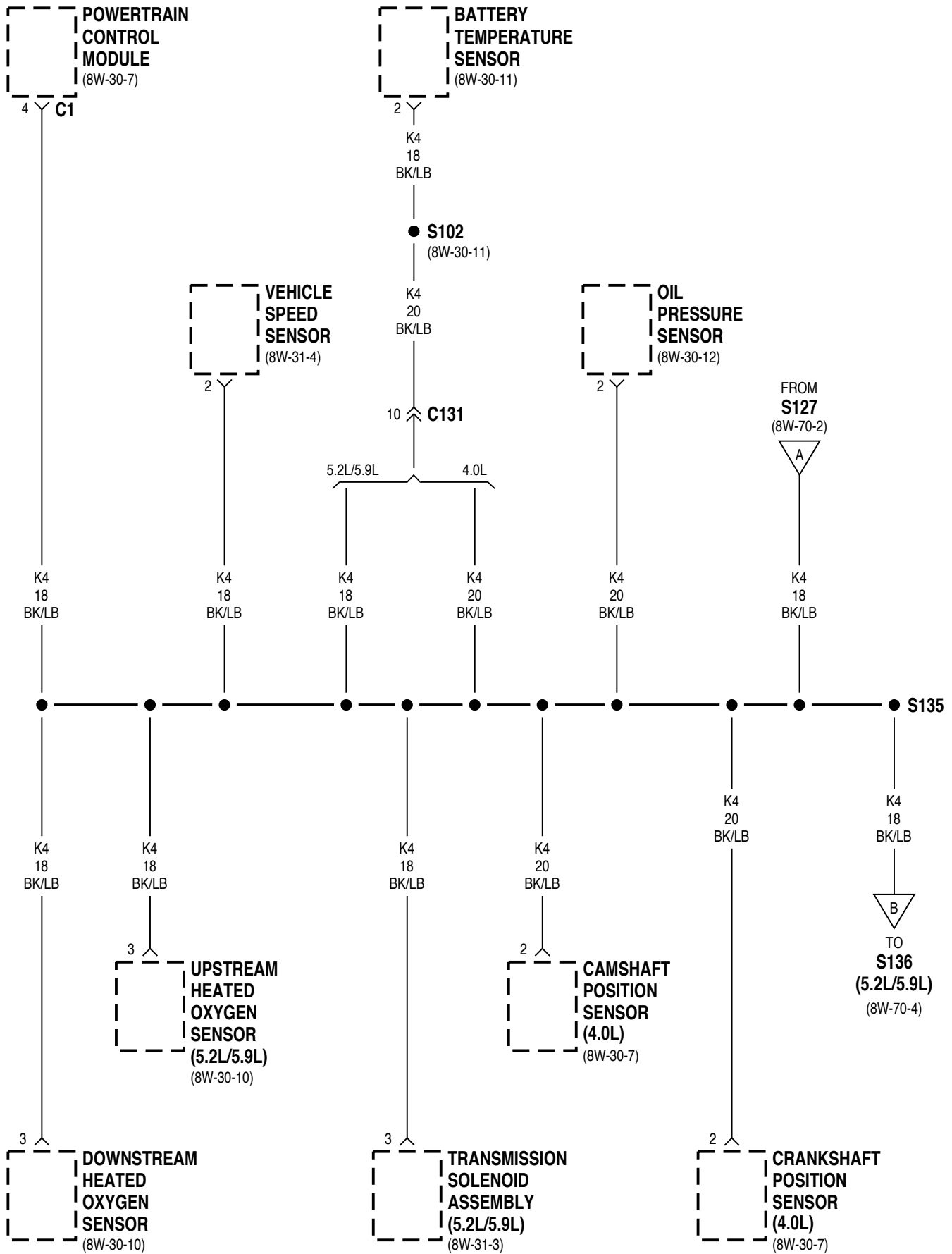


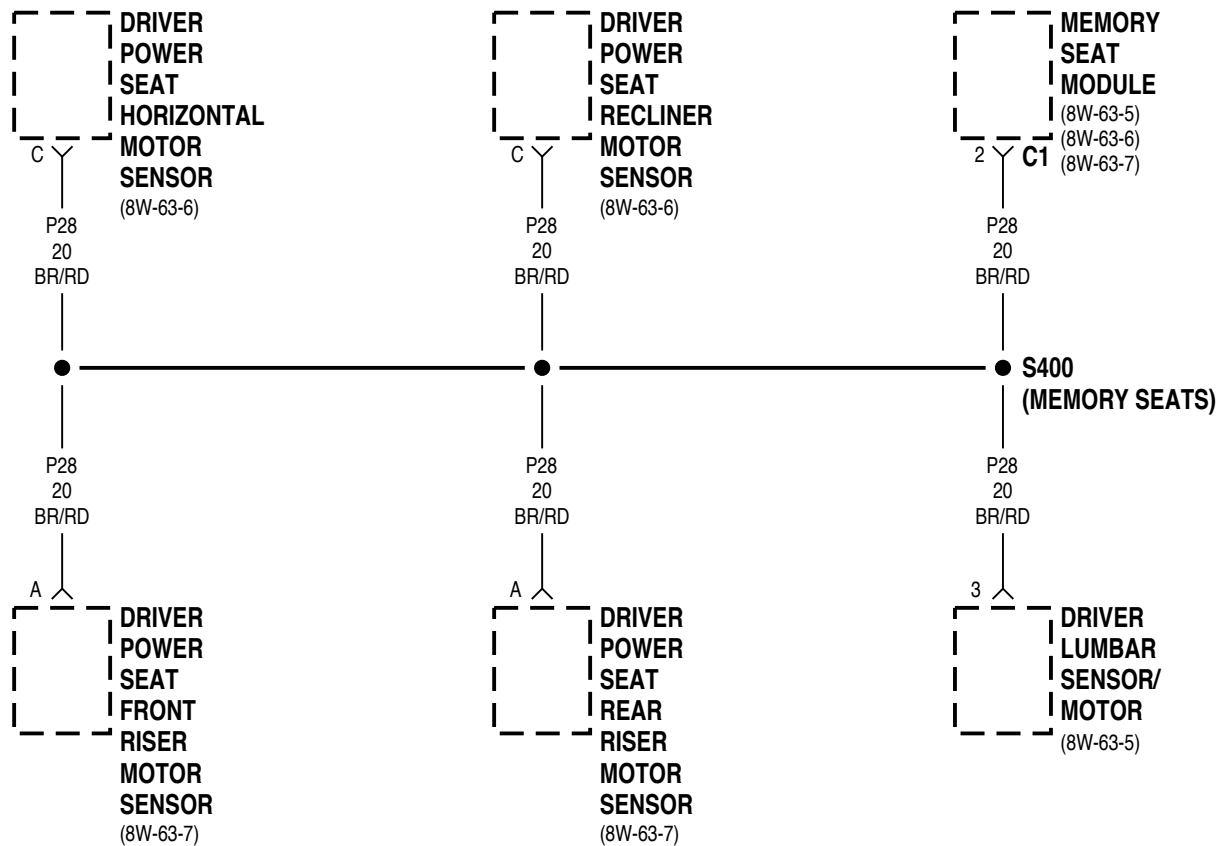
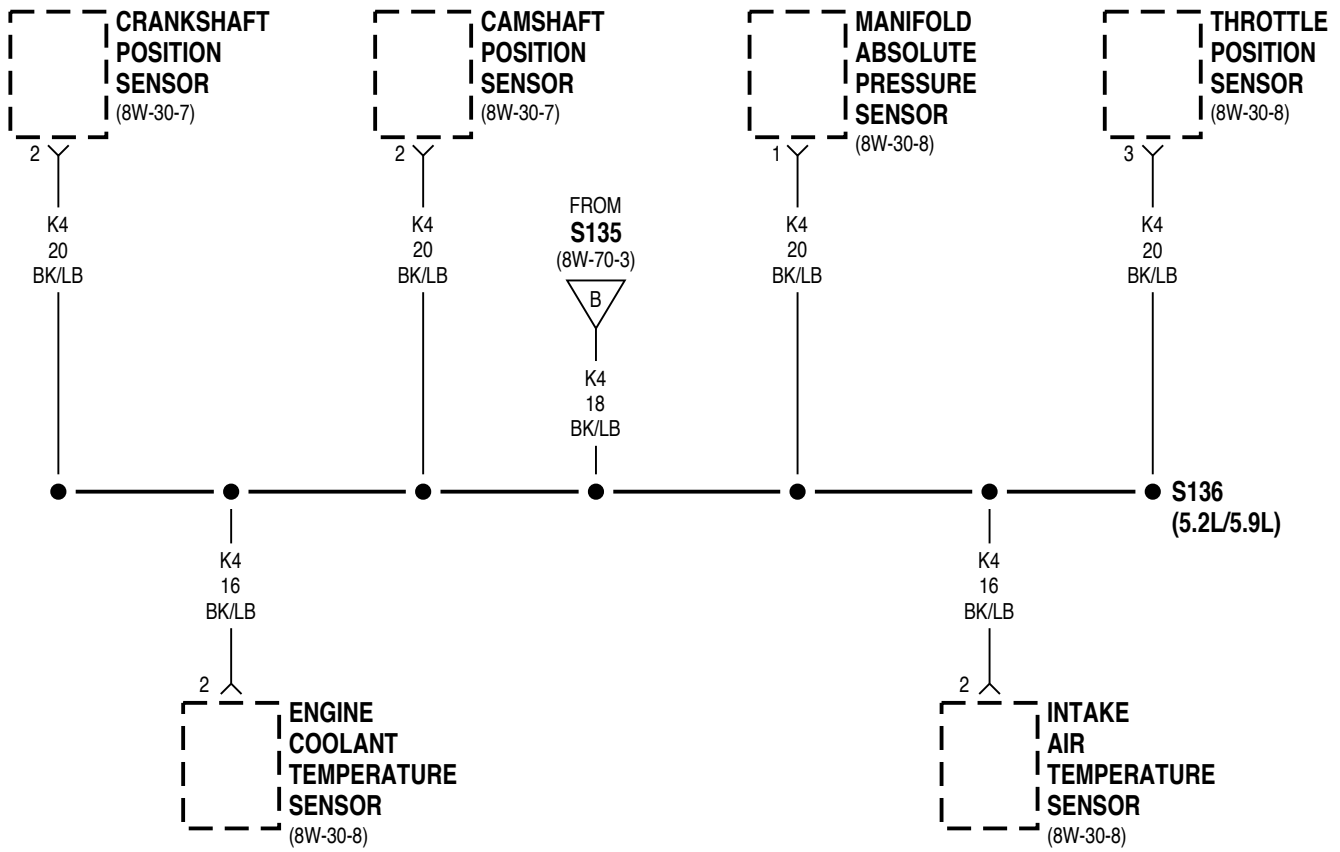
8W-70 SPLICE INFORMATION

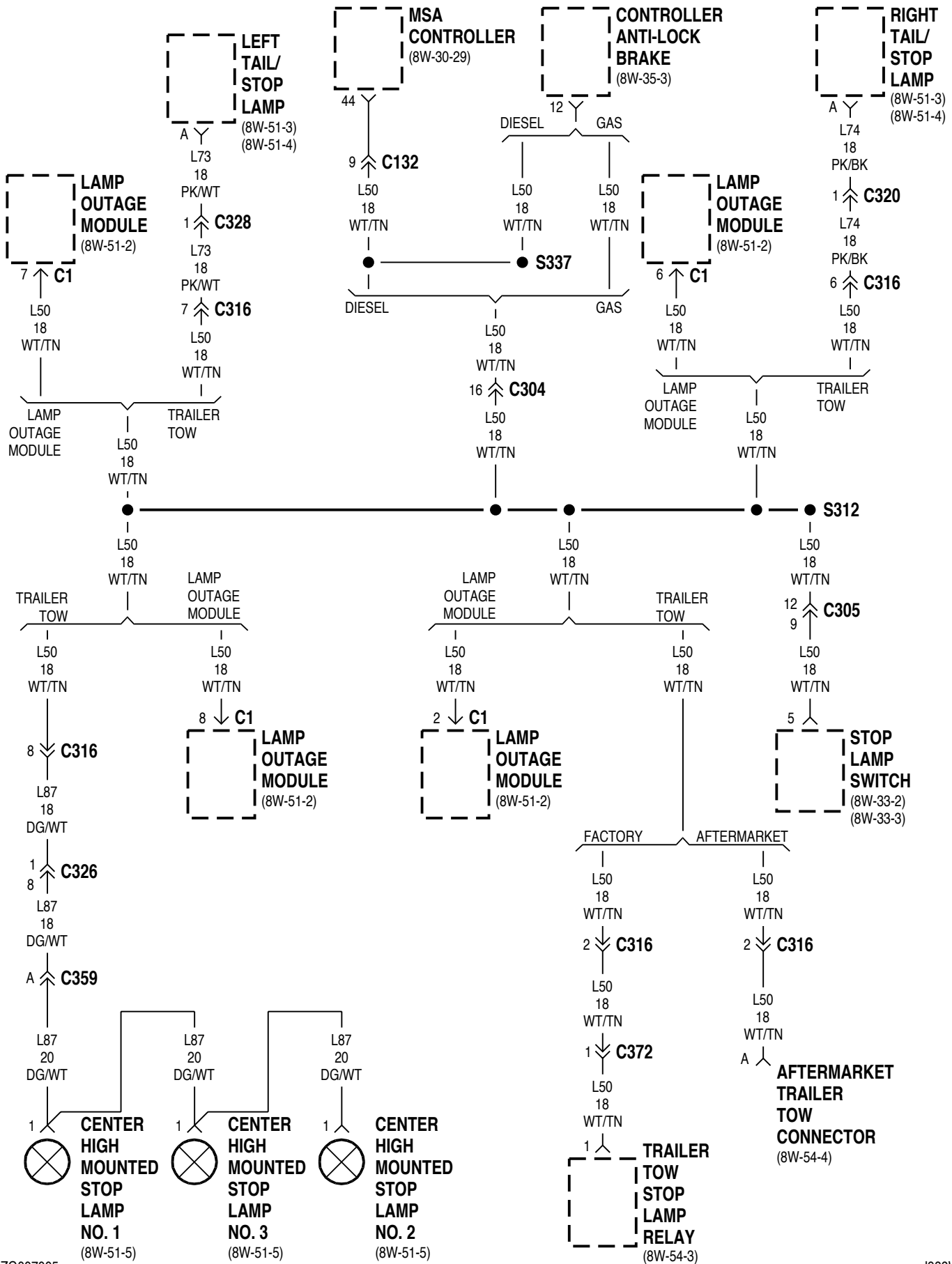
Component	Page	Component	Page
S100	8W-10-20	S212	8W-12-10
S101	8W-10-19	S214	8W-44-12
S102	8W-30-11	S215	8W-12-9
S103	8W-50-9	S216	8W-15-19
S104	8W-15-4, 5	S218	8W-12-14
S105	8W-12-28	S219	8W-42-6
S106	8W-10-9	S220	8W-15-19
S107	8W-50-3, 4	S221	8W-42-2, 5
S108	8W-50-3, 4	S222	8W-42-6, 8
S109	8W-15-8, 9	S223	8W-42-8
S110	8W-50-12	S226	8W-15-6, 7
S111	8W-50-12	S300	8W-47-4, 5
S112	8W-50-12	S301	8W-47-4, 5
S113	8W-50-12	S302	8W-15-20
S114	8W-50-12	S303	8W-45-9
S115	8W-50-12	S304	8W-15-15
S117	8W-40-6	S305	8W-39-5
S119	8W-12-10	S306	8W-30-4, 21
S120	8W-53-3	S307	8W-30-3, 20
S121	8W-15-8, 9	S308	8W-61-4
S122	8W-12-8	S309	8W-15-17
S124	8W-15-6, 7	S310	8W-61-4
S125	8W-15-6, 7	S311	8W-12-21
S126	8W-15-2	S312	8W-70-5
S127	8W-70-2	S314	8W-15-16
S128	8W-10-21, 23	S315	8W-12-12
S129	8W-10-21, 23	S316	8W-15-13
S130	8W-15-3, 4	S317	8W-12-14
S131	8W-33-4	S318	8W-12-12
S132	8W-70-2	S319	8W-47-4, 5
S133	8W-30-7	S320	8W-12-9
S134	8W-15-5	S321	8W-12-17
S135	8W-70-3	S322	8W-15-18
S136	8W-70-4, 6	S323	8W-12-11
S137	8W-10-7, 8	S324	8W-15-16
S138	8W-10-19	S325	8W-15-14
S140	8W-30-24	S326	8W-61-4
S141	8W-70-7	S327	8W-61-4
S142	8W-30-19	S328	8W-15-12
S144	8W-30-25	S329	8W-45-11
S145	8W-52-3	S330	8W-15-11
S146	8W-52-4	S331	8W-54-2
S149	8W-15-8	S332	8W-48-2
S149	8W-15-9	S333	8W-15-14
S150	8W-15-10	S334	8W-12-25
S151	8W-30-31	S335	8W-47-4, 5
S152	8W-15-4, 5	S336	8W-12-12
S153	8W-30-30, 31	S337	8W-70-5
S154	8W-30-30, 31	S340	8W-52-7
S170	8W-20-3	S343	8W-15-11
S171	8W-30-24	S400	8W-70-4
S172	8W-15-4	S401	8W-63-6
S173	8W-70-7	S402	8W-15-17
S174	8W-12-21	S403	8W-12-22
S175	8W-70-6	S404	8W-63-12
S178	8W-30-19	S405	8W-12-22
S180	8W-52-3	S406	8W-15-15
S183	8W-30-30	S407	8W-63-11
S200	8W-30-2	S412	8W-51-3
S201	8W-12-12	S416	8W-15-11
S202	8W-15-20	S417	8W-15-13
S203	8W-30-3, 20	S418	8W-51-6
S204	8W-30-4, 21	S419	8W-15-12
S205	8W-15-20	S420	8W-30-28
S206 (Gas)	8W-31-5	S421	8W-51-3
S206 (Diesel)	8W-33-3	S430	8W-47-11
S207	8W-12-8	S431	8W-33-4, 5
S209	8W-44-11	S432	8W-47-11
S210	8W-10-10, 11	S433	8W-33-4, 5
S211	8W-70-6		

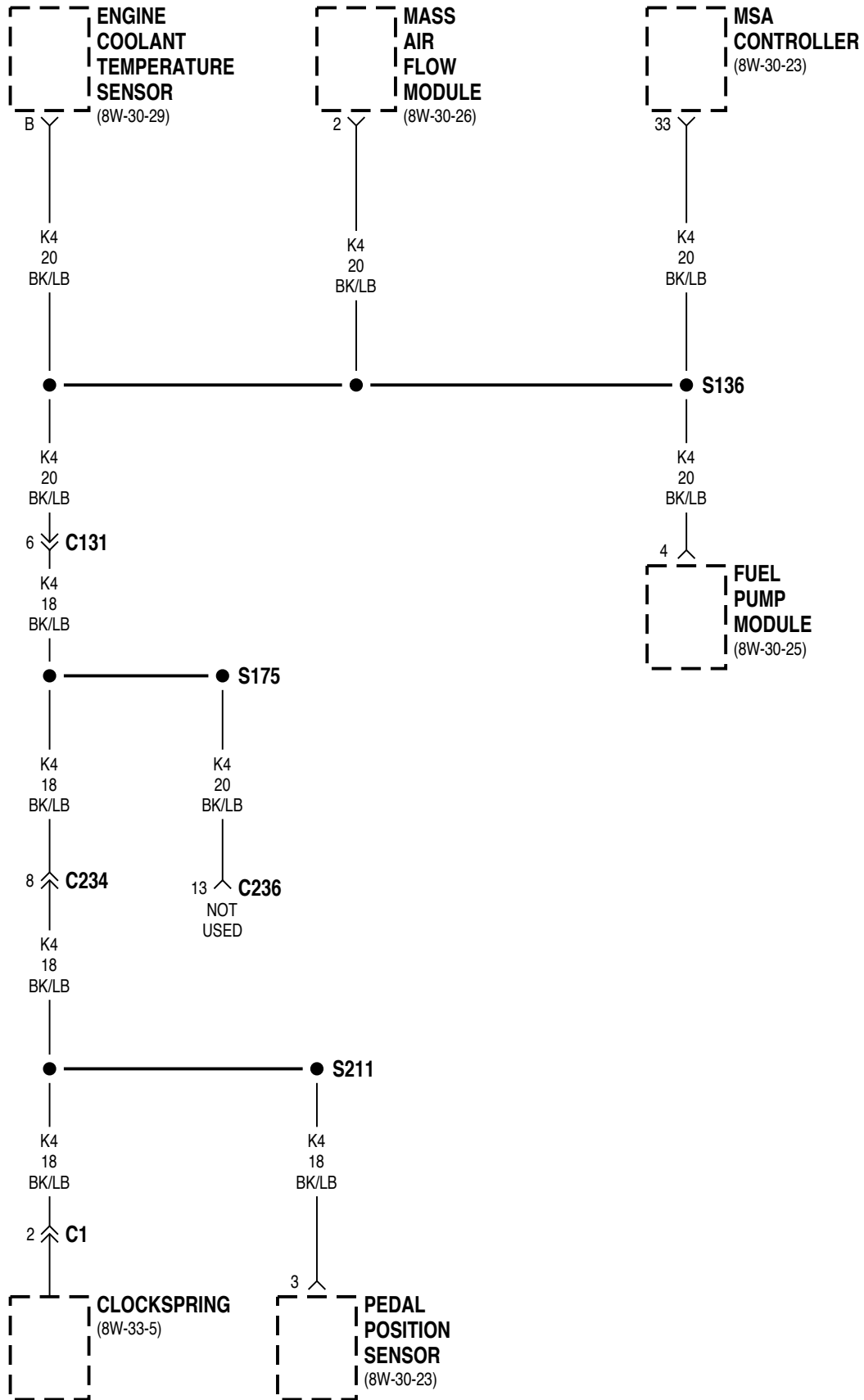


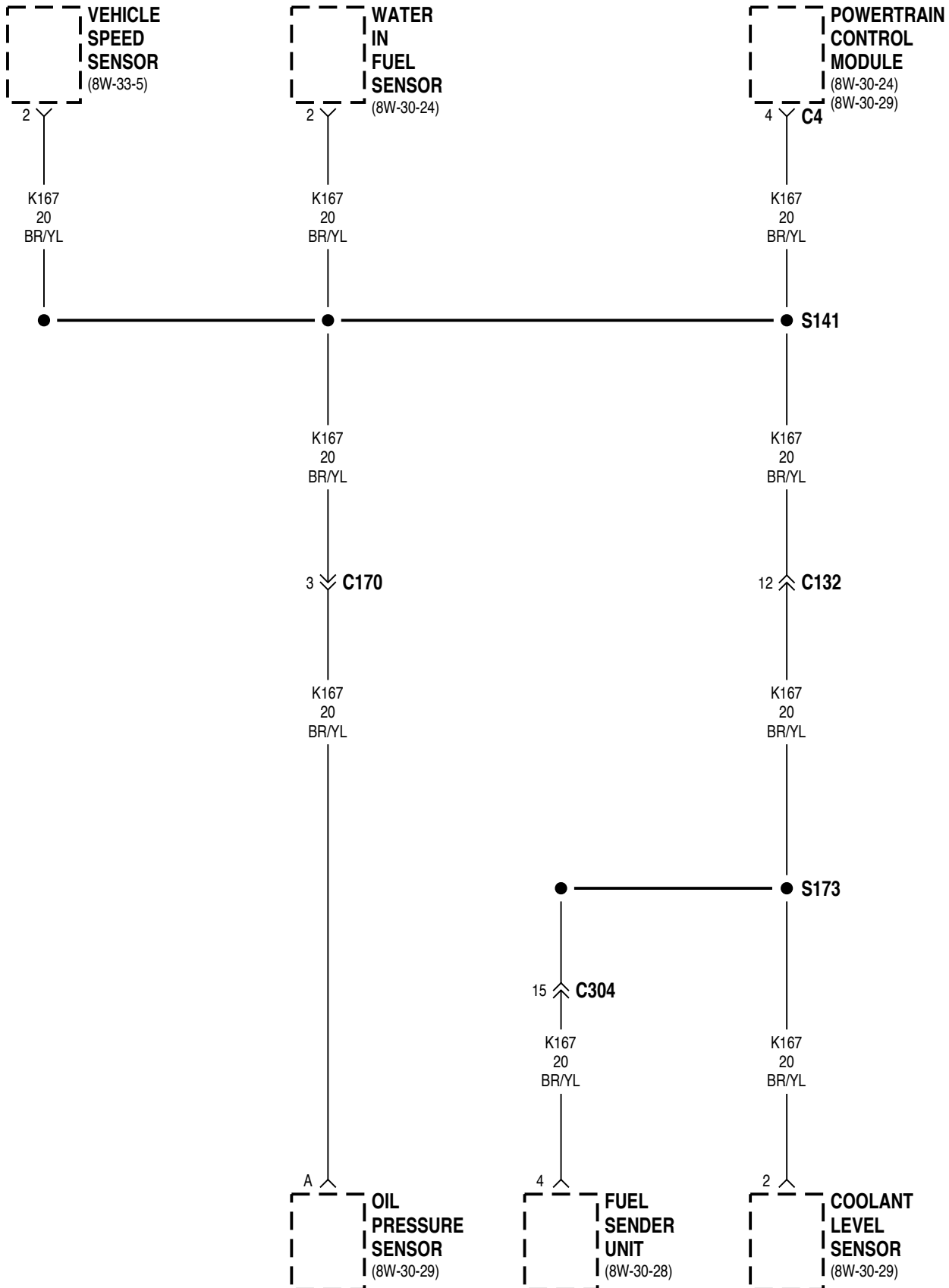
GAS











8W-80 CONNECTOR PIN-OUTS

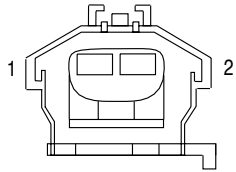
Component	Page	Component	Page
A/C Compressor Clutch	8W-80-4	C321	8W-80-22
A/C Heater Control-C1	8W-80-4	C322	8W-80-23
A/C Heater Control-C2	8W-80-5	C323	8W-80-23
A/C High Pressure Switch	8W-80-5	C324	8W-80-23
A/C Low Pressure Switch	8W-80-5	C325	8W-80-23
Aftermarket Trailer Tow Connector	8W-80-5	C326	8W-80-23
Airbag Control Module	8W-80-6	C328	8W-80-24
Ambient Temperature Sensor	8W-80-6	C329	8W-80-24
Ash Receiver Lamp	8W-80-6	C330 (LHD)	8W-80-24
Automatic Day/Night Mirror	8W-80-6	C330 (RHD)	8W-80-24
Automatic Headlamp Light Sensor/ VTSS LED	8W-80-6	C331	8W-80-24
Automatic Temperature Control Module	8W-80-7	C334	8W-80-25
Back-Up Lamp Switch	8W-80-7	C335	8W-80-25
Battery Temperature Sensor	8W-80-7	C343	8W-80-25
Blend Door Actuator	8W-80-8	C345	8W-80-26
Blower Motor	8W-80-8	C351	8W-80-26
Blower Motor Resistor Block	8W-80-8	C353	8W-80-26
Blower Power Module	8W-80-9	C359	8W-80-27
Body Control Module-C1	8W-80-9	C364	8W-80-27
Body Control Module-C2	8W-80-10	C371	8W-80-27
Body Control Module-C3	8W-80-11	C372	8W-80-27
Brake Pressure Switch	8W-80-11	Camshaft Position Sensor	8W-80-28
C102	8W-80-11	Cargo Lamp	8W-80-28
C131 (Diesel)	8W-80-11	Center High Mounted Stop Lamp No. 1	8W-80-28
C131 (Diesel)	8W-80-12	Center High Mounted Stop Lamp No. 2	8W-80-28
C131 (Gas) (LHD)	8W-80-12	Center High Mounted Stop Lamp No. 3	8W-80-29
C131 (Gas) (RHD)	8W-80-12	Cigar Lighter (RHD)	8W-80-29
C132 (Gas) (LHD)	8W-80-13	Cigar Lighter/Power Outlet (LHD)	8W-80-29
C132 (Gas) (RHD)	8W-80-13	Clockspring - C1	8W-80-29
C144	8W-80-14	Clockspring - C2	8W-80-29
C150	8W-80-14	Clockspring - C3	8W-80-29
C159	8W-80-14	Clutch Interlock Switch (M/T)	8W-80-30
C160	8W-80-14	Clutch Interlock Switch Jumper (A/T)	8W-80-30
C170 (Diesel)	8W-80-14	Controller Anti-Lock Brake	8W-80-30
C170 (Except Built-Up-Export)	8W-80-15	Coolant Level Sensor	8W-80-30
C170 (Gas) (Built-Up-Export)	8W-80-15	Cooling Fan Motor (Max Cooling)	8W-80-30
C171 (Built-Up-Export) (Max Cooling)	8W-80-15	Crankshaft Position Sensor (Diesel)	8W-80-31
C182 (Diesel)	8W-80-15	Crankshaft Position Sensor (Gas)	8W-80-31
C206 (Automatic Temperature Control)	8W-80-16	Cruise Switch No. 1	8W-80-31
C206 (Manual A/C-Heater)	8W-80-16	Cruise Switch No. 2	8W-80-31
C212	8W-80-17	Data Link Connector	8W-80-31
C231	8W-80-17	Daytime Running Lamp Module	8W-80-31
C233	8W-80-17	Diagnostic Connector (Max Cooling)	8W-80-32
C234	8W-80-18	Dome/Reading Lamp	8W-80-32
C235	8W-80-18	Downstream Heated Oxygen Sensor	8W-80-32
C236	8W-80-19	Driver Door Courtesy Lamp	8W-80-32
C300	8W-80-19	Driver Door Module- C1	8W-80-32
C301	8W-80-19	Driver Door Module- C2	8W-80-33
C302	8W-80-19	Driver Front Cylinder Lock Switch	8W-80-33
C304	8W-80-20	Driver Front Door Lock Motor	8W-80-33
C305	8W-80-20	Driver Front Door Speaker	8W-80-33
C307	8W-80-21	Driver Heated Seat Back	8W-80-33
C309 (LHD)	8W-80-21	Driver Heated Seat Cushion	8W-80-33
C309 (RHD)	8W-80-21	Driver Lumbar Motor	8W-80-33
C316	8W-80-22	Driver Lumbar Sensor/Motor	8W-80-34
C320	8W-80-22	Driver Lumbar Switch	8W-80-34
		Driver Outside Power Mirror	8W-80-34

Component	Page
Driver Power Seat Front Riser Motor	8W-80-34
Driver Power Seat Front Riser Motor Sensor (Memory)	8W-80-34
Driver Power Seat Horizontal Motor	8W-80-35
Driver Power Seat Horizontal Motor Sensor (Memory)	8W-80-35
Driver Power Seat Rear Riser Motor	8W-80-35
Driver Power Seat Rear Riser Motor Sensor (Memory)	8W-80-35
Driver Power Seat Recliner Motor	8W-80-35
Driver Power Seat Recliner Motor Sensor (Memory)	8W-80-36
Driver Power Seat Switch	8W-80-36
Driver Power Window Motor	8W-80-36
Driver Rear Door Lock Motor	8W-80-36
Driver Rear Door Speaker	8W-80-36
Driver Rear Power Window Motor	8W-80-37
Driver Rear Power Window Switch	8W-80-37
Driver Seat Heater Control Module (LHD)	8W-80-37
Driver Seat Heater Control Module (RHD)	8W-80-37
Duty Cycle Evap/Purge Solenoid	8W-80-38
Electronic Vacuum Modulator (Diesel)	8W-80-38
Engine Coolant Temperature Sensor (2.5L/5.9L)	8W-80-38
Engine Coolant Temperature Sensor (4.0L)	8W-80-38
Engine Coolant Temperature Sensor (Diesel)	8W-80-38
Engine Starter Motor	8W-80-39
Factory Trailer Tow Connector	8W-80-39
Floor Console Lamps	8W-80-39
Four Wheel Drive Switch	8W-80-39
Fuel Heater	8W-80-40
Fuel Injector No. 1	8W-80-40
Fuel Injector No. 2	8W-80-40
Fuel Injector No. 3	8W-80-40
Fuel Injector No. 4	8W-80-40
Fuel Injector No. 5	8W-80-40
Fuel Injector No. 6	8W-80-41
Fuel Injector No. 7 (5.2L/5.9L)	8W-80-41
Fuel Injector No. 8 (5.2L/5.9L)	8W-80-41
Fuel Pump Module (Diesel)	8W-80-41
Fuel Pump Module (Gas)	8W-80-42
Fuel Sender Unit (Diesel)	8W-80-42
Fuel Timing Solenoid (Diesel)	8W-80-42
G Switch	8W-80-43
Generator (Diesel)	8W-80-43
Generator (Gas)	8W-80-43
Glove Box Lamp	8W-80-43
Glow Plug Relay (Diesel)	8W-80-43
Headlamp Leveling Switch (Built-Up-Export)	8W-80-44
Headlamp Switch	8W-80-44
High Pressure Cut-Out Switch (Max Cooling)	8W-80-45
High Speed Blower Motor Relay	8W-80-45
High Speed Cooling Fan Relay (Max Cooling)	8W-80-45
Horn No. 1	8W-80-45
Horn No. 2	8W-80-45
Idle Air Control Motor (2.5L)	8W-80-46

Component	Page
Idle Air Control Motor (4.0L)	8W-80-46
Ignition Coil	8W-80-46
Ignition Relay (Max Cooling)	8W-80-46
Ignition Switch	8W-80-46
In-Car Temperature Sensor	8W-80-46
Instrument Cluster	8W-80-47
Intake Air Temperature Sensor	8W-80-47
Junction Block- C1	8W-80-47
Junction Block- C10	8W-80-50
Junction Block- C11	8W-80-50
Junction Block- C13	8W-80-50
Junction Block- C14	8W-80-51
Junction Block- C15	8W-80-51
Junction Block- C2	8W-80-48
Junction Block- C3	8W-80-48
Junction Block- C4	8W-80-48
Junction Block- C5	8W-80-48
Junction Block- C6	8W-80-49
Junction Block- C7	8W-80-49
Junction Block- C8	8W-80-49
Junction Block- C9	8W-80-50
Key-In Switch/Halo Lamp	8W-80-51
Lamp Outage Module- C1	8W-80-52
Lamp Outage Module- C2	8W-80-52
Leak Detection Pump (Except Built-Up-Export)	8W-80-52
Left Airbag Sensor	8W-80-52
Left Back-Up Lamp	8W-80-53
Left Courtesy Lamp	8W-80-53
Left Fog Lamp	8W-80-53
Left Front Park Lamp	8W-80-53
Left Front Side Marker Lamp	8W-80-53
Left Front Turn Signal Lamp	8W-80-54
Left Front Wheel Speed Sensor	8W-80-54
Left Headlamp (Built-Up-Export)	8W-80-54
Left Headlamp (Except Built-Up-Export)	8W-80-54
Left Headlamp Leveling Motor	8W-80-54
Left Instrument Panel Speaker	8W-80-55
Left License Lamp	8W-80-55
Left Park Lamp	8W-80-55
Left Park/Turn Signal Marker	8W-80-55
Left Rear Fog Lamp (Built-Up-Export)	8W-80-55
Left Rear Side Marker Lamp (Except Built-Up-Export)	8W-80-56
Left Rear Turn Signal Lamp	8W-80-56
Left Rear Wheel Speed Sensor	8W-80-56
Left Side Repeater	8W-80-56
Left Tail/Stop Lamp	8W-80-57
Left Visor/Vanity Lamp	8W-80-57
Liftgate Ajar Switch	8W-80-57
Liftgate Cylinder Lock Switch	8W-80-57
Liftgate Lock Motor	8W-80-57
Liftglass Ajar Switch	8W-80-58
Liftglass Limit Switch	8W-80-58
Liftglass Push Button	8W-80-58
Liftglass Release Solenoid	8W-80-58
Low Speed Cooling Fan Relay (Max Cooling)	8W-80-58
Lower Hose Coolant Switch (Max Cooling)	8W-80-58

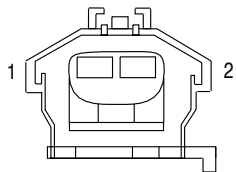
Component	Page
Manifold Absolute Pressure Sensor	8W-80-58
Mass Air Flow Module	8W-80-59
Memory Seat Module- C1	8W-80-59
Memory Seat Module- C2	8W-80-60
Mode Door Actuator	8W-80-61
MSA Controller (Diesel)	8W-80-61
Multi-Function Switch	8W-80-62
Needle Sensor (Diesel)	8W-80-63
Oil Pressure Sensor (Diesel)	8W-80-63
Oil Pressure Sensor (Gas)	8W-80-63
Output Shaft Speed Sensor	8W-80-63
Overhead Console	8W-80-63
Park/Neutral Position Switch	8W-80-64
Passenger Airbag	8W-80-64
Passenger Door Courtesy Lamp	8W-80-64
Passenger Door Module- C1	8W-80-64
Passenger Front Cylinder Lock Switch	8W-80-64
Passenger Front Door Lock Motor	8W-80-64
Passenger Front Door Speaker	8W-80-65
Passenger Front Power Window Motor	8W-80-65
Passenger Heated Seat Back	8W-80-65
Passenger Heated Seat Cushion	8W-80-65
Passenger Lumbar Motor	8W-80-65
Passenger Lumbar Switch	8W-80-65
Passenger Outside Power Mirror - C2	8W-80-66
Passenger Power Seat Front Riser Motor	8W-80-66
Passenger Power Seat Horizontal Motor	8W-80-66
Passenger Power Seat Rear Riser Motor	8W-80-66
Passenger Power Seat Recliner Motor	8W-80-66
Passenger Power Seat Switch	8W-80-67
Passenger Rear Door Lock Motor	8W-80-67
Passenger Rear Door Speaker	8W-80-67
Passenger Rear Power Window Motor	8W-80-67
Passenger Rear Power Window Switch	8W-80-67
Passenger Seat Heater Control Module (LHD)	8W-80-68
Passenger Seat Heater Control Module (RHD)	8W-80-68
Pedal Position Sensor (Diesel)	8W-80-68
Power Amplifier - C1 (Limited Plus)	8W-80-69
Power Amplifier - C1 (Premium)	8W-80-70
Power Amplifier - C2 (Limited Plus)	8W-80-69
Power Amplifier - C2 (Premium)	8W-80-70
Power Outlet	8W-80-71
Powertrain Control Module- C1	8W-80-71
Powertrain Control Module- C2	8W-80-72
Powertrain Control Module- C3	8W-80-73
Powertrain Control Module- C4 (Diesel)	8W-80-74
Radio- C1	8W-80-75
Radio- C2	8W-80-75
Radio- C3	8W-80-75
Rear Speaker	8W-80-75
Rear Washer Pump Motor	8W-80-76

Component	Page
Rear Wiper Module	8W-80-76
Rear Wiper/Washer Switch	8W-80-75
Recirculation Door Actuator (Automatic Temperature Control)	8W-80-76
Remote Radio Switch No. 1	8W-80-76
Remote Radio Switch No. 2	8W-80-76
Right Airbag Sensor	8W-80-77
Right Back-Up Lamp	8W-80-77
Right Courtesy Lamp	8W-80-77
Right Fog Lamp	8W-80-77
Right Front Park Lamp	8W-80-77
Right Front Side Marker Lamp	8W-80-78
Right Front Turn Signal Lamp	8W-80-78
Right Front Wheel Speed Sensor	8W-80-78
Right Headlamp	8W-80-78
Right Headlamp (Except Built-Up-Export)	8W-80-78
Right Headlamp Leveling Motor	8W-80-78
Right Instrument Panel Speaker	8W-80-79
Right License Lamp	8W-80-79
Right Park/Turn Signal Marker	8W-80-79
Right Rear Fog Lamp (Built-Up-Export)	8W-80-79
Right Rear Side Marker Lamp (Built-Up-Export)	8W-80-80
Right Rear Turn Signal Lamp	8W-80-80
Right Rear Wheel Speed Sensor	8W-80-80
Right Side Repeater	8W-80-81
Right Tail/Stop Lamp	8W-80-81
Right Visor/Vanity Lamp	8W-80-81
Seat Belt Switch	8W-80-81
Shift Interlock	8W-80-81
Solar Sensor	8W-80-81
Stop Lamp Switch	8W-80-82
Sunroof Control Module	8W-80-82
Switch Pod	8W-80-82
Throttle Position Sensor	8W-80-83
Trailer Tow Circuit Breaker	8W-80-83
Trailer Tow Left Turn Relay	8W-80-83
Trailer Tow Right Turn Relay	8W-80-83
Trailer Tow Stop Lamp Relay	8W-80-84
Transmission Solenoid Assembly	8W-80-84
Underhood Lamp	8W-80-84
Upper Hose Coolant Switch (Max Cooling)	8W-80-84
Upstream Heated Oxygen Sensor	8W-80-84
Vehicle Information Center/ Graphic Display Module	8W-80-85
Vehicle Speed Control Servo	8W-80-85
Vehicle Speed Sensor (Gas)	8W-80-85
Vehicle Speed Sensor (Diesel)	8W-80-86
Water In Fuel Sensor (Diesel)	8W-80-86
Windshield Washer Pump Motor	8W-80-86
Windshield Wiper Motor	8W-80-86
Wiper Fluid Level Sensor	8W-80-86



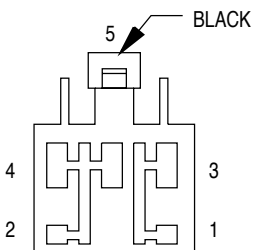
A/C COMPRESSOR CLUTCH (DIESEL)

CAV	CIRCUIT	FUNCTION
1	C2 18DB/YL	A/C COMPRESSOR CLUTCH RELAY OUTPUT
2	Z1 18BK/TN*	GROUND
2	Z12 18BK/TN**	GROUND



A/C COMPRESSOR CLUTCH (GAS)

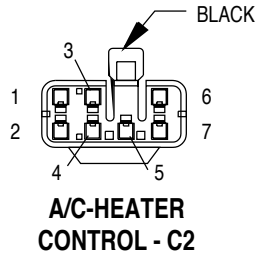
CAV	CIRCUIT	FUNCTION
1	C2 18DB/YL** ●	A/C CLUTCH RELAY OUTPUT
1	Z12 18BK/TN ●●	GROUND
1	Z1 18BK* ●	GROUND
2	C2 18DB/YL* ●	A/C CLUTCH RELAY OUTPUT
2	Z1 18BK** ●	GROUND
2	C2 18DB/YL ●●	A/C CLUTCH RELAY OUTPUT



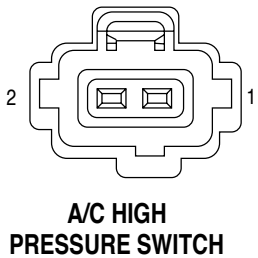
A/C-HEATER CONTROL - C1

CAV	CIRCUIT	FUNCTION
1	C4 14TN	LOW BLOWER MOTOR DRIVER
2	C5 14LG	M1 BLOWER MOTOR DRIVER
3	C7 12BK/TN	HIGH SPEED BLOWER MOTOR
4	C1 14DG	GROUND
5	C6 14LB	M2 BLOWER MOTOR DRIVER

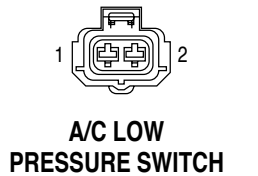
●● 5.2L/5.9L * RHD
● 4.0L ** LHD



CAV	CIRCUIT	FUNCTION
1	-	-
2	C36 20DB/RD	BLEND AIR DOOR POSITION SWITCH SIGNAL
3	C34 20VT/WT	GROUND
4	E2 20OR	PANEL LAMP DRIVER
5	-	-
6	F71 20DG/PK	FUSED IGNITION SWITCH OUTPUT (RUN)
7	C90 20LG	A/C SELECT INPUT



CAV	CIRCUIT	FUNCTION
1	C21 18DB/OR	A/C PRESSURE SWITCH SENSE
2	Z1 18BK	GROUND

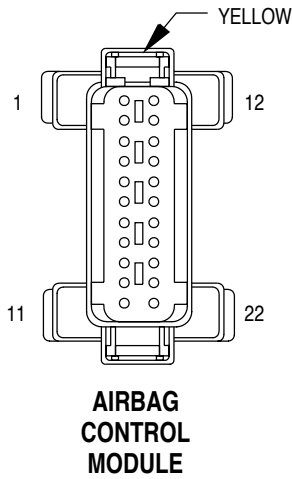


CAV	CIRCUIT	FUNCTION
1	C3 18DB/BK*	A/C PRESSURE SWITCH SENSE
1	C13 18DB**	A/C COMPRESSOR CLUTCH RELAY CONTROL
2	C21 18DB/OR	A/C PRESSURE SWITCH SENSE

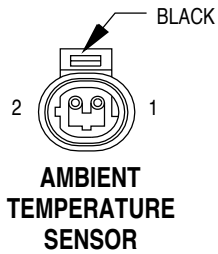


CAV	CIRCUIT	FUNCTION
A	L50 18WT/TN	STOP LAMP SWITCH OUTPUT
B	L90 18DB/RD	PARK LAMP RELAY OUTPUT
C	L60 18TN	RIGHT TURN SIGNAL
D	F70 16PK/BK	FUSED B(+)

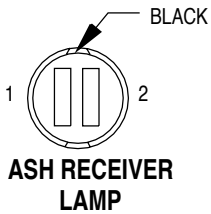
* GAS
** DIESEL



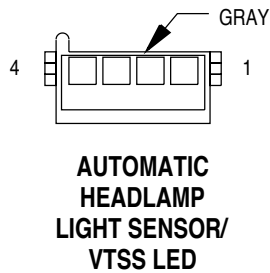
CAV	CIRCUIT	FUNCTION
1	R45 18DG/LB	DRIVER AIRBAG LINE 2
2	R43 18BK/LB	DRIVER AIRBAG LINE 1
3	-	-
4	-	-
5	R42 18BK/YL	PASSENGER AIRBAG LINE 1
6	R44 18DG/YL	PASSENGER AIRBAG LINE 2
7	-	-
8	-	-
9	-	-
10	Z6 16BK/PK	GROUND
11	-	-
12	-	-
13	-	-
14	-	-
15	-	-
16	-	-
17	G5 18DB/WT	FUSED IGNITION SWITCH OUTPUT (ST-RUN)
18	D2 18WT/BK	CCD BUS (-)
19	D1 18VT/BR	CCD BUS (+)
20	F20 18WT	FUSED IGNITION SWITCH OUTPUT (RUN)
21	-	-
22	-	-



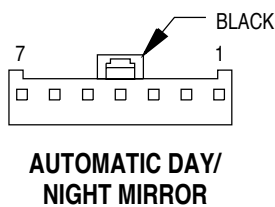
CAV	CIRCUIT	FUNCTION
1	D41 20LG/WT	SENSOR RETURN
2	C8 20DG/RD	AMBIENT TEMPERATURE SENSOR SIGNAL



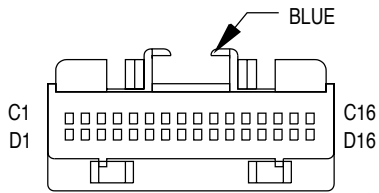
CAV	CIRCUIT	FUNCTION
1	E2 20OR	PANEL LAMP DRIVER
2	Z1 20BK	GROUND



CAV	CIRCUIT	FUNCTION
1	F75 18VT	FUSED B(+)
2	G69 20BK/LG	VTSS INDICATOR LAMP DRIVER
3	L109 20WT	ULTRALIGHT LIGHT SENSOR DRIVER
4	L110 20OR/BK	ULTRALIGHT LIGHT SENSOR SIGNAL

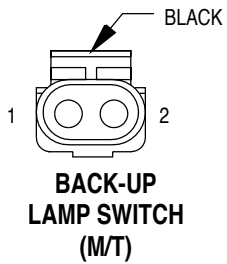


CAV	CIRCUIT	FUNCTION
1	F83 20BK/VT	FUSED IGNITION SWITCH OUTPUT (RUN)
2	Z1 20BK	GROUND
3	L10 20BK/RD	BACK-UP LAMP SWITCH OUTPUT
4	P112 20BK/WT	POWER MIRROR B(-)
5	P114 20BK/YL	POWER MIRROR B(-)
6	-	-
7	-	-



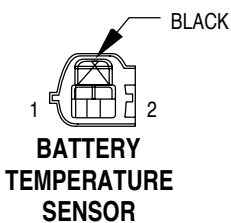
**AUTOMATIC
TEMPERATURE
CONTROL
MODULE**

CAV	CIRCUIT	FUNCTION
C1	C37 20YL	MODE DOOR MOTOR DRIVER
C2	C35 20DG/YL	BLEND AIR DOOR MOTOR DRIVER
C3	C39 20WT	MODE DOOR MOTOR POSITION SENSE
C4	-	-
C5	-	-
C6	C90 20LG	A/C SELECT INPUT
C7	-	-
C8	C40 20BR/WT	5 VOLT SUPPLY
C9	C43 18YL/BR	BLOWER POWER MODULE OUTPUT
C10	D1 18VT/BR	CCD BUS(+)
C11	D2 18WT/BK	CCD BUS(-)
C12	F71 20DG/PK	FUSED IGNITION SWITCH OUTPUT (RUN)
C13	F60 20WT/RD	FUSED B(+)
C14	C36 20RD/WT	BLEND AIR DOOR FEEDBACK SIGNAL
C15	-	-
C16	-	-
D1	C38 20DB	MODE DOOR MOTOR DRIVER
D2	C42 18PK/DB	HIGH SPEED BLOWER MOTOR RELAY SIGNAL
D3	C32 20DB/GY	RECIRCULATION DOOR MOTOR DRIVER
D4	C33 20DB/RD	RECIRCULATION DOOR MOTOR DRIVER
D5	C41 20GY/DB	HIGH SPEED BLOWER MOTOR RELAY CONTROL
D6	C34 20DB/WT	BLEND AIR DOOR MOTOR DRIVER
D7	Z4 20PK	GROUND
D8	-	-
D9	D41 20LG/WT	SENSOR GROUND
D10	-	-
D11	-	-
D12	C10 20RD/TN	IN-CAR TEMPERATURE SENSOR SIGNAL
D13	E2 20OR	PANEL LAMP DRIVER
D14	-	-
D15	C47 20BK/WT	SOLAR SENSOR SIGNAL
D16	-	-



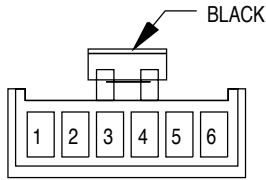
**BACK-UP
LAMP SWITCH
(M/T)**

CAV	CIRCUIT	FUNCTION
1	F83 18YL/DG	FUSED IGNITION SWITCH OUTPUT (RUN)
2	L10 18BR/LG	BACK-UP SWITCH OUTPUT



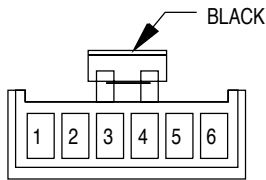
**BATTERY
TEMPERATURE
SENSOR**

CAV	CIRCUIT	FUNCTION
1	T222 18RD/YL	BATTERY TEMPERATURE SENSE SIGNAL
2	K4 18BK/LB	SENSOR GROUND



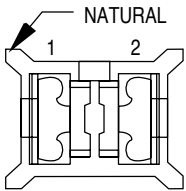
BLEND DOOR ACTUATOR (AUTOMATIC TEMPERATURE CONTROL)

CAV	CIRCUIT	FUNCTION
1	C40 20DG/YL	5-VOLT SUPPLY
2	C36 20DB/RD	BLEND AIR DOOR FEEDBACK SIGNAL
3	D41 20LG/WT	SENSOR GROUND
4	-	-
5	C35 20DB/WT	BLEND AIR DOOR MOTOR DRIVER
6	C34 20VT/WT	BLEND AIR DOOR MOTOR DRIVER



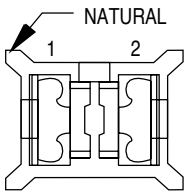
BLEND DOOR ACTUATOR (MANUAL A/C-HEATER)

CAV	CIRCUIT	FUNCTION
1	F71 20PK/DG	FUSED IGNITION SWITCH OUTPUT (RUN)
2	C40 20WT/YL	5-VOLT SUPPLY
3	C36 20DB/RD	BLEND AIR DOOR POSITION SWITCH SIGNAL
4	C34 20VT/WT	COMMON DOOR DRIVER
5	-	-
6	-	-



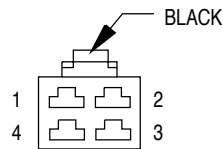
BLOWER MOTOR (AUTOMATIC TEMPERATURE CONTROL)

CAV	CIRCUIT	FUNCTION
1	C42 12RD	HIGH SPEED BLOWER MOTOR RELAY SIGNAL
2	Z4 12BK	GROUND



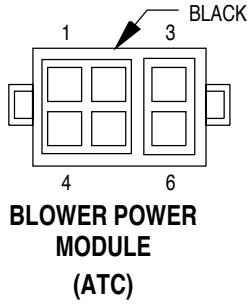
BLOWER MOTOR (MANUAL A/C-HEATER)

CAV	CIRCUIT	FUNCTION
1	A19 12RD	BLOWER MOTOR DRIVER
2	C7 12BK	GROUND

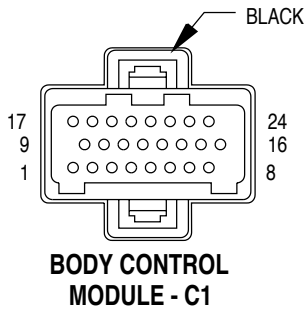


BLOWER MOTOR RESISTOR BLOCK (MANUAL A/C-HEATER)

CAV	CIRCUIT	FUNCTION
1	C4 14TN	LOW BLOWER MOTOR DRIVER
2	C6 14LB	M2 BLOWER MOTOR DRIVER
3	C7 12BK	HIGH SPEED BLOWER MOTOR
4	C5 14LG	M1 BLOWER MOTOR DRIVER

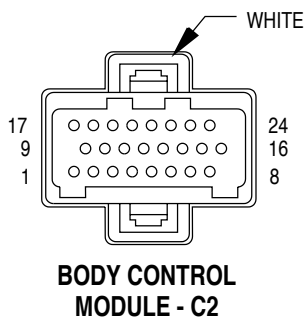


CAV	CIRCUIT	FUNCTION
1	C42 12BR/RD	BLOWER MOTOR DRIVER
2	-	-
3	A19 10RD	FUSED B(+)
4	C43 18BR/YL	BLOWER POWER MODULE OUTPUT
5	Z4 18BK	GROUND
6	-	-

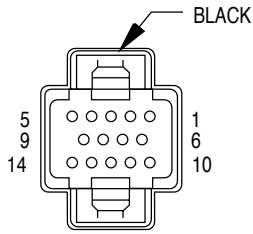


CAV	CIRCUIT	FUNCTION
1	V51 18WT	WINDSHIELD WIPER SWITCH SIGNAL
2	D41 20LG/WT	SENSOR GROUND
3	-	-
4	-	-
5	C8 20DG/RD	AMBIENT TEMPERATURE SENSOR SIGNAL
6	M11 20PK/LB	SWITCHED COURTESY LAMP FEED
7	L24 20LB/RD	AUTO HEADLAMP SWITCH SENSE
8	C80 20DB/YL	REAR WINDOW DEFOGGER SWITCH SENSE
9	L4 16VT/OR	DIMMER SWITCH LOW BEAM OUTPUT
10	-	-
11	-	-
12	G70 20BR/TN*	HOOD AJAR SWITCH SENSE
13	-	-
14	G26 20LB	KEY-IN IGNITION SWITCH SENSE
15	L35 20BR/WT	FOG LAMP SWITCH OUTPUT
16	Z2 20BK/OR	GROUND
17	L90 20DB/RD	PARK LAMP RELAY OUTPUT
18	F99 20OR	FUSED IGNITION SWITCH OUTPUT (ST-RUN)
19	D1 18VT/BR	CCD BUS (+)
20	D2 18WT/BK	CCD BUS (-)
21	-	-
22	-	-
23	G69 20BK/LG	VTSS INDICATOR LAMP DRIVER
24	L3 16RD/OR	DIMMER SWITCH HIGH BEAM OUTPUT

* LHD

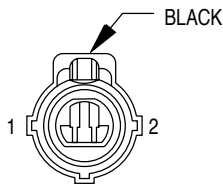


CAV	CIRCUIT	FUNCTION
1	-	-
2	L109 20WT	SENSOR GROUND
3	709 20RD/BK	RADIO CONTROL MUX
4	V66 16VT/WT	WIPER PARK SWITCH SENSE
5	-	-
6	M112 20BR/LG	COURTESY LAMP RELAY CONTROL
7	C90 20LG	A/C SELECT INPUT
8	F75 18VT	FUSED B(+)
9	L110 20OR/BK	SENSOR SIGNAL
10	-	-
11	-	-
12	714 20BK/OR	AUTOMATIC HEADLAMP RELAY CONTROL
13	X4 20GY/OR	HORN RELAY CONTROL
14	C14 20WT/RD	REAR WINDOW DEFOGGER RELAY CONTROL
15	V23 20BR/PK	FUSED IGNITION SWITCH OUTPUT (RUN-ACC)
16	E2 20OR	PANEL LAMP DRIVER
17	V11 18TN/BK	WASHER SWITCH OUTPUT
18	V50 18LG/WT	WIPER SWITCH MODE SENSE
19	-	-
20	707 20BK/WT	PANEL LAMP DIMMER SIGNAL
21	L79 20TN	PARK LAMP RELAY CONTROL
22	L95 20DG/YL	FOG LAMP RELAY CONTROL
23	V18 20YL/LG	INTERMITTENT WIPER RELAY CONTROL
24	Z1 16BK	GROUND



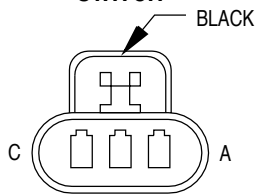
BODY CONTROL MODULE - C3

CAV	CIRCUIT	FUNCTION
1	G78 20TN/BK	LIFTGATE AJAR SWITCH SENSE
2	G9 20GY/BK	RED BRAKE WARNING LAMP DRIVER
3	G76 18TN/YL	PASSENGER REAR DOOR AJAR SWITCH SENSE
4	G75 18TN	LEFT FRONT DOOR AJAR SWITCH SENSE
5	-	-
6	M4 20WT/LG	LIFTGATE COURTESY LAMP DISABLE
7	-	-
8	Z2 18BK/OR	GROUND
9	G74 18TN/RD	PASSENGER FRONT DOOR AJAR SWITCH SENSE
10	G71 20VT/YL	VTSS DISARM SENSE
11	-	-
12	-	-
13	G77 18TN/OR	DRIVER REAR DOOR AJAR SWITCH SENSE
14	G10 20LG/RD	SEAT BELT SWITCH SENSE



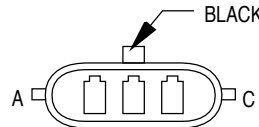
BRAKE PRESSURE SWITCH

CAV	CIRCUIT	FUNCTION
1	Z2 16BK	GROUND
2	G9 16GY/BK	RED BRAKE WARNING LAMP DRIVER



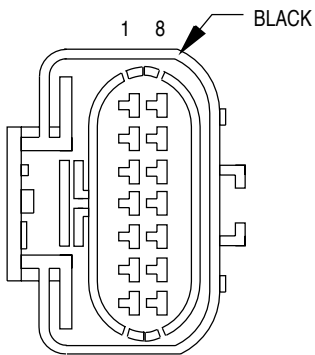
C102

CAV	CIRCUIT
A	L65 18LG/DB
B	L90 18DB/RD
C	Z1 18BK



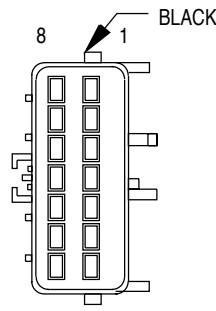
C102

CAV	CIRCUIT
A	L65 18LG/DB
B	L90 18DB/RD
C	Z1 18BK



C131 (DIESEL)

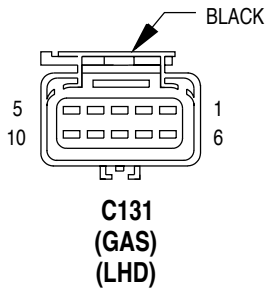
CAV	CIRCUIT
1	-
2	Z1 18BK*
3	G40 18LB/BK
4	F99 20OR
5	G18 20PK/BK
6	K4 18BK/LB
7	L10 18BR/LG
8	G118 20PK/DB
9	A64 14OR/DB
10	Z1 12BK
11	F6 18WT/RD
12	A142 16DG/OR
13	F83 18YL/DG
14	C3 18DB/BK



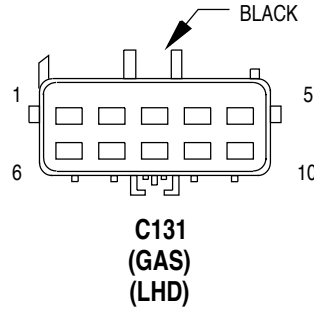
C131 (DIESEL)

CAV	CIRCUIT
1	-
2	Z1 18BK/TN*
3	G40 18LB/BK
4	F99 20OR
5	G18 20PK/BK
6	K4 20BK/LB
7	L10 18BR/LG
8	G118 20PK/DB
9	A64 14DG/WT
10	Z1 12BK
11	F6 18WT/RD
12	A142 16DG/OR
13	F83 18YL/DG
14	C3 18DB/BK

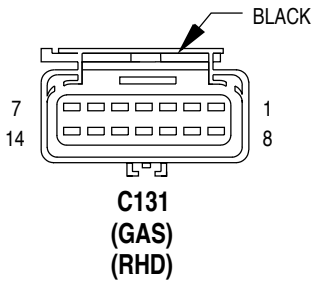
* RHD



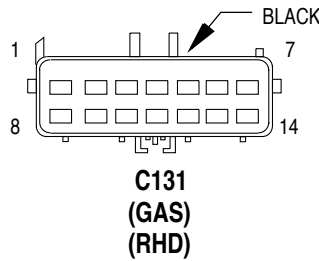
CAV	CIRCUIT
1	T20 18LB
2	F99 20OR
3	-
4	A142 18DG/OR
5	F5 14RD/YL
6	L10 18BR/LG
7	C2 18DB/YL*
8	G28 20LG/OR
9	-
10	K4 20BK/LB



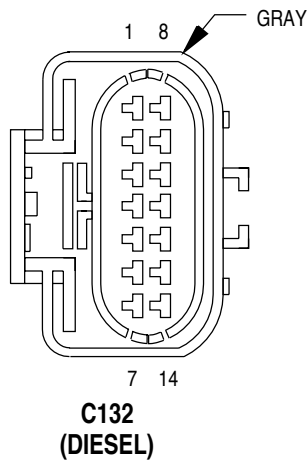
CAV	CIRCUIT
1	T20 18LB
2	F99 18OR
3	-
4	A142 18DG/OR
5	F5 14RD/YL
6	L10 18BR/LG
7	C2 18DB/YL*
8	G28 20LG/OR •
9	-
10	K4 18BK/LB*
10	K4 20BK/LB**



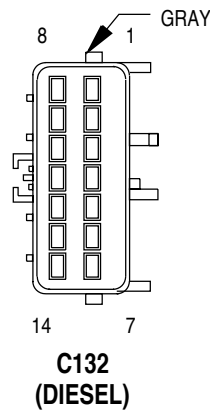
CAV	CIRCUIT
1	T20 18LB
2	F99 20OR
3	-
4	A142 18DG/OR
5	F5 14RD/YL
6	L10 18BR/LG
7	C2 18DB/YL
8	G28 20LG/OR
9	-
10	K4 20BK/LB
11	V30 20DB/LG
12	V35 18LG/RD
13	V36 18TN/RD
14	Z4 20BK



CAV	CIRCUIT
1	T20 18LB
2	F99 18OR
3	-
4	A142 18DG/OR
5	F5 14RD/YL
6	L10 18BR/LG
7	C2 18DB/YL
8	G28 20LG/OR
9	-
10	K4 20BK/LB
11	V30 20DB/LG
12	V35 18LG/RD
13	V36 18TN/RD
14	Z4 20BK

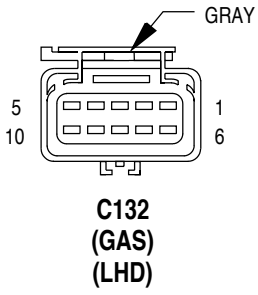


CAV	CIRCUIT
1	L53 20BR
2	Z1 18BK
3	Z2 18BK/OR
4	D2 18WT/BK
5	D1 18VT/BR
6	T106 20GY/OR
7	T107 20BK/RD
8	V32 20YL/RD
9	L50 18WT/TN
10	C13 18DB
11	G28 20LG/OR
12	K167 20BR/YL
13	-
14	K900 20PK/BK

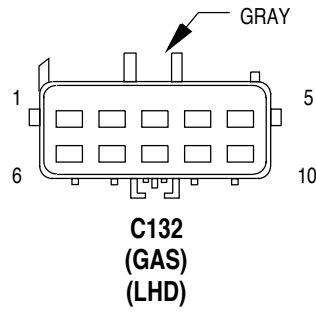


CAV	CIRCUIT
1	L53 20BR
2	Z1 18BK
3	Z2 18BK/OR
4	D2 18WT/BK
5	D1 18VT/BR
6	T106 20GY/OR
7	T107 20BK/RD
8	V32 18YL/RD
9	L50 18WT/TN
10	C13 16DB/RD
11	G28 20LG/OR
12	K167 20BR/YL
13	-
14	K900 20PK/BK

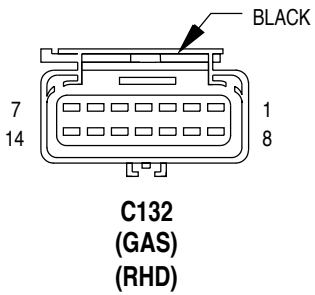
• 4WD
* 5.2L/5.9L
** 4.0L



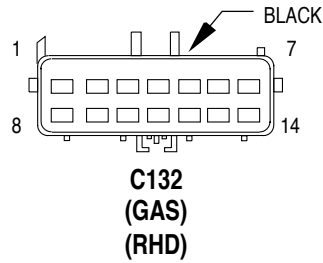
CAV	CIRCUIT
1	Z1 18BK
2	Z2 18BK/OR
3	-
4	T41 20BK/WT
5	G7 18WT/OR*
6	K20 18DG
7	T66 20BR/OR
8	F83 18YL/DG
9	T106 20GY/OR
10	T107 20BK/RD



CAV	CIRCUIT
1	Z1 18BK
2	Z2 18BK/OR
3	-
4	T41 20BK/WT
5	G7 18WT/OR
6	K20 18DG
7	T66 18BR/OR
8	F83 18YL/DG
9	T106 20GY/OR •
10	T107 20BK/RD •

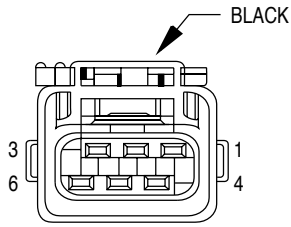


CAV	CIRCUIT
1	Z1 18BK
2	Z2 18BK/OR
3	-
4	T41 20BK/WT
5	-
6	K20 18DG
7	T66 20BR/OR
8	F83 18YL/DG
9	T106 20GY/OR
10	T107 20BK/RD
11	Z1 18BK
12	C21 18DB/OR
13	-
14	-



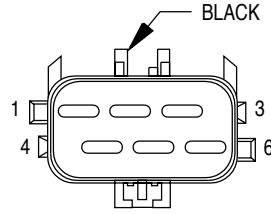
CAV	CIRCUIT
1	Z1 18BK
2	Z2 18BK/OR
3	-
4	T41 20BK/WT
5	G7 18WT/OR
6	K20 18DG
7	T66 18BR/OR
8	F83 18YL/DG
9	T106 20GY/OR
10	T107 20BK/RD
11	Z1 18BK
12	C21 18DB/OR
13	-
14	-

• 4WD
* LHD



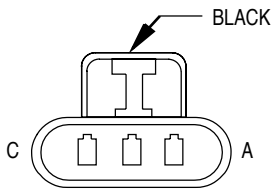
C144

CAV	CIRCUIT
1	C2 18DB/YL
2	K20 18DG
2	D83 20BK/PK**
3	K72 18DG/VT
3	D84 20BK/WT**
4	Z1 18BK
4	K95 20PK/WT**
5	C21 18DB/OR
6	T40 12LG/BK



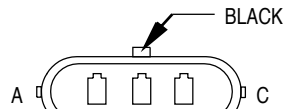
C144

CAV	CIRCUIT
1	C2 18DB/YL
2	K20 18DG
2	D83 20BK/PK**
3	K72 18DG/VT
3	D84 20BK/WT**
4	Z1 18BK
4	K95 20PK**
5	C21 18DB/OR
6	T40 12LG/BK



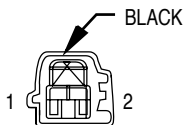
C150

CAV	CIRCUIT
A	L64 18TN/DB
B	L90 18DB/RD
C	Z1 18BK



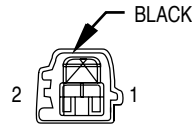
C150

CAV	CIRCUIT
A	L64 18TN/DB
B	L90 18DB/RD
C	Z1 18BK



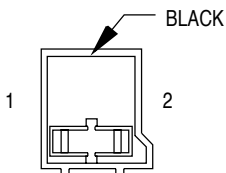
C159

CAV	CIRCUIT
1	M1 18PK
2	Z1 18BK



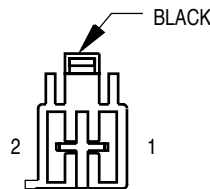
C159

CAV	CIRCUIT
1	M1 18PK
2	Z1 18BK**
2	Z4 18BK*



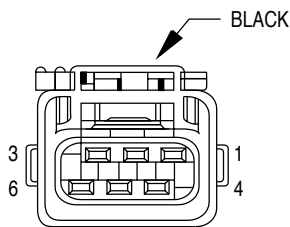
C160

CAV	CIRCUIT
1	A19 10RD ■
1	A19 12RD ■■
2	Z4 12BK ▲
2	Z5 12BK ▲▲



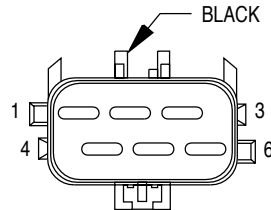
C160

CAV	CIRCUIT
1	A19 12RD/VT
2	Z4 12BK



**C170
(DIESEL)**

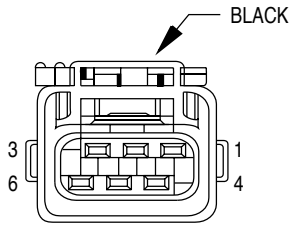
CAV	CIRCUIT
1	T40 14LG/BK
2	G60 20GY/YL
3	K167 20BR/YL
4	K6 18VT/WT
5	-
6	-



**C170
(DIESEL)**

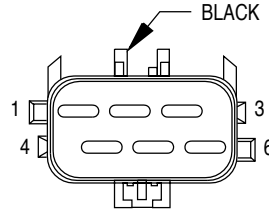
CAV	CIRCUIT
1	T40 12LG/BK
2	G60 20GY/YL
3	K167 20BR/YL
4	K7 20OR/WT
5	-
6	-

- * GAS
- ** DIESEL
- 4.0L
- ▲ LHD
- ▲▲ RHD
- ATC
- MANUAL A/C-HEATER



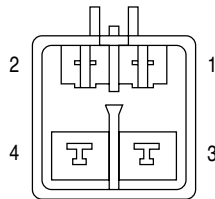
**C170
(GAS)
(BUILT-UP-EXPORT)**

CAV	CIRCUIT
1	-
2	K20 18DG
3	K72 18DG/VT
4	-
5	-
6	T40 12LG/BK



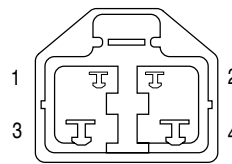
**C170
(GAS)
(BUILT-UP-EXPORT)**

CAV	CIRCUIT
1	-
2	K20 18DG
3	K72 18DG/VT
4	-
5	-
6	T40 12LG/BK



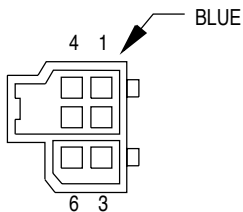
**C170 (EXCEPT
BUILT-UP-EXPORT)
C171 (BUILT-
UP-EXPORT)
(MAX COOLING)**

CAV	CIRCUIT
1	F99 16OR
2	-
3	-
4	F143 10LG/RD



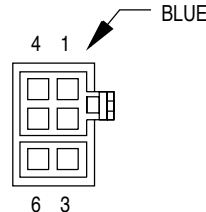
**C170 (EXCEPT
BUILT-UP-EXPORT)
C171 (BUILT-
UP-EXPORT)
(MAX COOLING)**

CAV	CIRCUIT
1	F99 16OR
2	-
3	-
4	F143 10LG/RD



**C182
(DIESEL)**

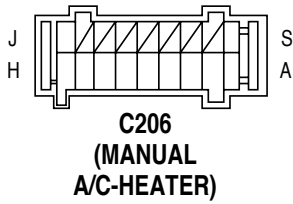
CAV	CIRCUIT
1	K255 20WT/DG
2	K151 20WT
3	K6 20VT/WT
4	K22 20OR/DB



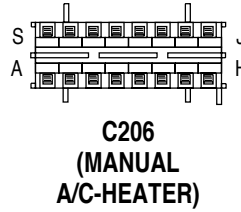
**C182
(DIESEL)**

CAV	CIRCUIT
1	K255 20WT/DG
2	K151 20WT/RD
3	K6 20VT/WT
4	K22 20OR/DB

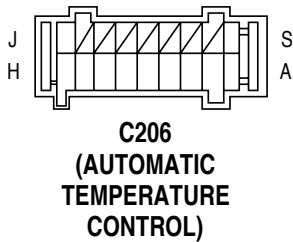
* GAS
** DIESEL



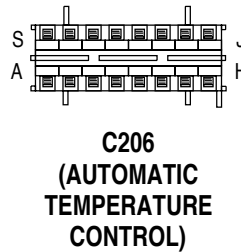
CAV	CIRCUIT
A	-
B	C7 12BK/TN
C	C6 14LB
D	C5 14LG
E	C4 14TN
F	C36 20DB/RD
G	F71 20PK/DG
H	C34 20VT/WT
J	Z4 12BK
K	-
L	-
M	-
N	-
P	-
R	-
S	-



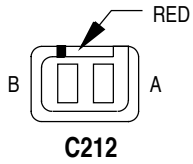
CAV	CIRCUIT
A	-
B	C7 12BK/TN
C	C6 14LB
D	C5 14LG
E	C4 14TN
F	C36 20DB/RD
G	F71 20PK/DG
H	C34 20VT/WT
J	C1 14DG
K	-
L	-
M	-
N	-
P	-
R	-
S	-



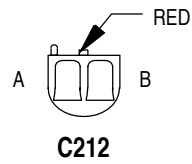
CAV	CIRCUIT
A	C39 20YL
B	C37 20TN/BK
C	C35 20DB/WT
D	C36 20DB/RD
E	C34 20VT/WT
F	F71 20PK/DG
G	C33 20VT/OR
H	C32 20LB/DG
J	C38 20DG
K	C40 20DG/YL
L	C41 20BR
M	C42 12BR/RD
N	C43 18BR/YL
P	Z4 20BK
R	-
S	D41 20LG/WT



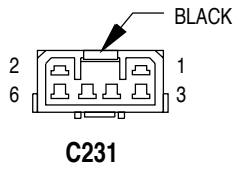
CAV	CIRCUIT
A	C39 20WT
B	C37 20YL
C	C35 20DG/YL
D	C36 20RD/WT
E	C34 20DB/WT
F	F71 20PK/DG
G	C33 20DB/RD
H	C32 20DB/GY
J	C38 20DB
K	C40 20BR/WT
L	C41 20GY/DB
M	C42 18PK/DB
N	C43 18YL/BR
P	Z4 20PK
R	-
S	D41 20LG/WT



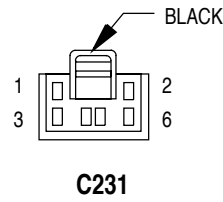
CAV	CIRCUIT
A	G42 20LB/RD
B	T19 20YL/BK



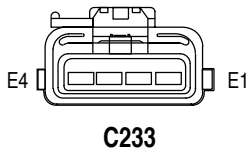
CAV	CIRCUIT
A	G28 20LG/OR
B	107 20BK/RD



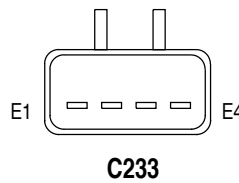
CAV	CIRCUIT
1	D1 18VT/BR
2	D2 18WT/BK
3	P112 20YL/WT
4	P114 20YL/BK
5	F86 16LG/BK
6	-



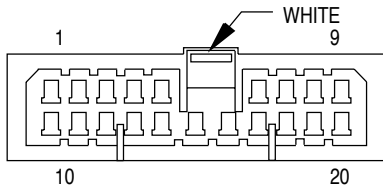
CAV	CIRCUIT
1	D1 18VT/BR
2	D2 18WT/BK
3	P112 20BK/WT
4	P114 20BK/YL
5	F86 16LG/BK
6	-



CAV	CIRCUIT
1	A1 12RD/WT
2	F61 16WT/OR
3	-
4	T141 14YL/RD

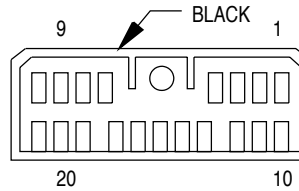


CAV	CIRCUIT
1	A1 12RD/WT
2	F61 16WT/OR
3	-
4	T141 14YL/RD



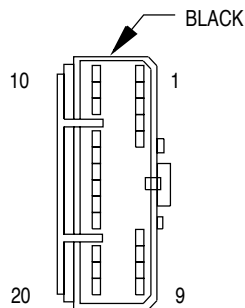
C234

CAV	CIRCUIT
1	V11 18TN/BK
2	L3 16RD/OR
3	L4 16VT/OR
4	V4 18RD/YL
5	G9 16GY/BK
6	G18 16PK/BK
6	G118 20PK/DB**
7	G29 16BK/TN
8	K4 20BK/LB*
8	K4 18BK/LB**
9	V32 18YL/RD
10	L65 18LG/DB
11	C8 20DG/RD
12	G34 20RD/GY ●●
12	L3 16RD/OR*
13	L53 18BR
13	L53 20BR**
14	D21 20BK/PK
14	D83 20BK/PK
15	D84 20BK/WT
16	L53 20BR*
17	V20 18WT/BK
18	V6 16DB
19	K95 18PK
19	K95 20PK**
20	T9 18OR



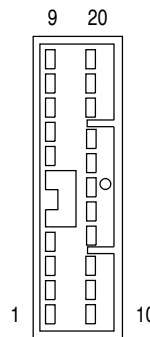
C234

CAV	CIRCUIT
1	V11 18TN/BK
2	L3 16RD/OR
3	L4 16VT/OR
4	V4 18RD/YL
5	G9 18GY/BK
6	G18 20PK/BK
7	G29 20BK/TN
8	K4 18BK/LB
9	V32 20YL/RD
10	L65 18LG/DB
11	C8 20DG/RD
12	L3 16RD/OR
13	L53 20BR
14	D83 20BK/PK
14	D83 20BK/PK
15	D84 20BK/WT
16	L53 20BR ■
17	V20 18WT/BK
18	V6 16DB
19	K95 20PK
20	T9 20OR/BK



C235

CAV	CIRCUIT
1	G68 18BR/YL*
2	V30 20DB/LG
2	Z2 20BK**
3	T106 20GY/OR
4	G70 20BR/TN
5	G19 18GY/BK*
5	205 18WT/VT**
6	D98 20WT* ▲
7	D1 18VT/BR ▲
8	D2 18WT/BK ▲
9	D21 20BK/PK
10	V18 20YL/LG
11	D41 20LG/WT
12	S1 20BK/YL* ▲
13	S2 20BK/LG* ▲
14	S3 20PK/WT* ▲
14	F83 18YL/DG ▲▲
15	S4 20VT* ▲
16	V3 18BR/WT
17	V66 18VT/WT
18	F83 18YL/DG
19	D1 18VT/BR
20	D2 18WT/BK



C235

CAV	CIRCUIT
1	D83 20BK/PK ▲
2	D2 18WT/BK ▲
3	D1 18VT/BR ▲
4	D98 20WT▲
5	205 20WT/VT
6	G70 20BR/TN ▲
7	T106 20GY/OR
8	V30 20DB/LG
9	G68 20BR/YL
10	D2 18WT/BK
11	D1 18VT/BR
12	F83 18YL/DG
13	V66 16VT/WT
14	V3 18BR/WT
15	S4 20VT* ▲
16	S3 20PK/WT* ▲
17	S2 20BK/LG* ▲
18	S1 20BK/YL* ▲
19	D41 20LG/WT
20	V18 20YL/LG

* GAS

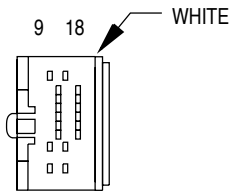
** DIESEL

● UNITED STATES

●● DAYTIME RUNNING LAMPS

▲ LHD

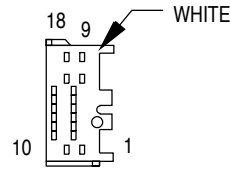
▲▲ RHD ■ ATC



1 10

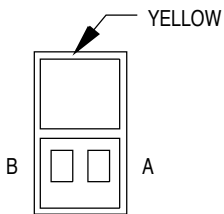
C236

CAV	CIRCUIT
1	-
2	L101 20RD
3	L102 20WT
4	L103 20LB
5	L104 20LG
6	L105 20PK
7	L106 20YL
8	F99 20OR
9	-
10	-
11	Z1 18BK
12	Z2 18BK/OR
13	K4 20BK/LB**
14	-
15	-
16	-
17	-
18	-



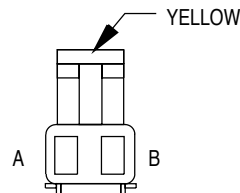
C236

CAV	CIRCUIT
1	-
2	L101 20RD
3	L102 20WT
4	L103 20LB
5	L104 20LG
6	L105 20PK
7	L106 20YL
8	F99 20OR
9	-
10	-
11	Z1 18BK
12	Z2 18BK/OR
13	-
14	-
15	-
16	-
17	-
18	-



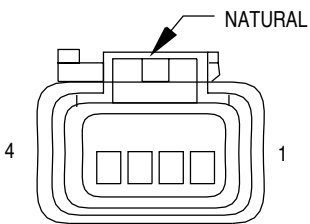
C300

CAV	CIRCUIT
A	R44 18DB
B	R42 18VT



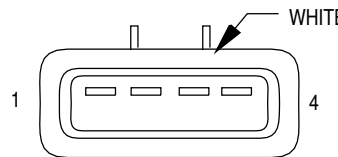
C300

CAV	CIRCUIT
A	R44 18DG/YL
B	R42 18BK/YL



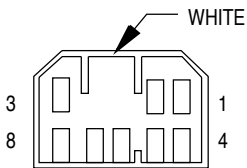
C301

CAV	CIRCUIT
1	C15 12BK/WT
2	Z1 14BK
3	P7 18LB/BK
4	P8 18LB/WT



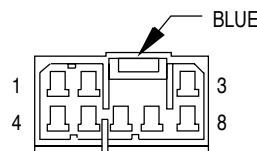
C301

CAV	CIRCUIT
1	C15 12BK/WT
2	Z1 14BK
3	P7 20LB*
4	P8 20LB/WT*



C302

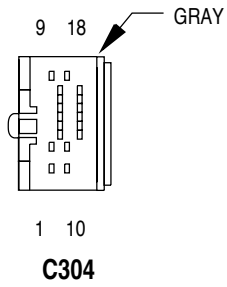
CAV	CIRCUIT
1	D1 18VT/BR
2	D2 18WT/BK
3	-
4	F71 20PK/DG
5	-
6	E2 20OR
7	P112 20YL/WT
8	P114 20YL/BK



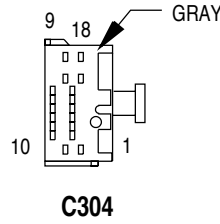
C302

CAV	CIRCUIT
1	D1 18VT/BR
2	D2 18WT/BK
3	-
4	F71 18PK/DG
5	-
6	E2 18OR
7	P112 18YL/WT
8	P114 18YL/BK

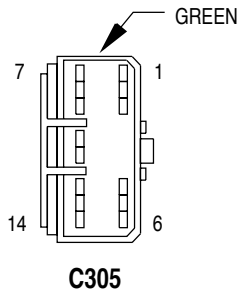
* HEATED SEATS
** DIESEL



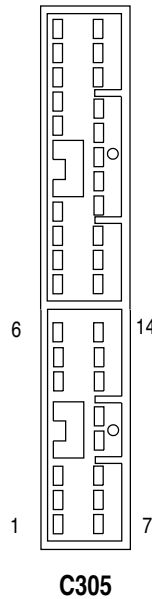
CAV	CIRCUIT
1	-
2	G9 20GY/BK
3	B1 18YL/DB
4	B2 18YL
5	-
6	B41 18YL/VT
7	B42 18TN/WT
8	B43 18PK/OR
9	-
10	G40 18LB/BK
11	-
12	B3 18LG/DB
13	B4 18LG
14	-
15	K4 20BK/LB*
15	K167 20BR/YL**
16	L50 18WT/TN
17	-
18	A64 16DG/WT*
18	A64 16OR/DB**



CAV	CIRCUIT
1	-
2	G9 20GY/BK
3	B1 20YL/DB
4	B2 20YL
5	-
6	B41 20YL/VT
7	B42 20TN/WT
8	B43 20PK/OR
9	-
10	G40 20LB/BK
11	-
12	B3 20LG/DB
13	B4 20LG
14	-
15	K167 20BR/YL
16	L50 18WT/TN
17	-
18	A64 16DG/WT

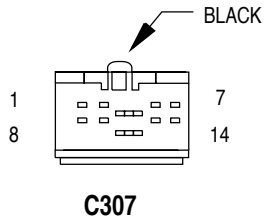


CAV	CIRCUIT
1	-
2	-
3	V24 18BR/OR
4	V20 18BK/WT
5	X55 16BR/RD
6	X53 16DG
7	X54 16VT
8	X56 16DB
9	Z5 14BK/LB
10	X51 16BR/YL
11	X57 16BR/LB
12	L50 18WT/TN
13	X52 16DB/WT
14	X58 16DB/OR

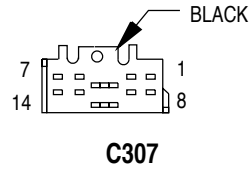


CAV	CIRCUIT
1	X53 20DG
2	X55 20BR/RD
3	V20 18WT/BK
4	V24 18BR/OR
5	-
6	-
7	X58 20DB/OR
8	X52 20DB/WT
9	L50 18WT/TN
10	X57 20BR/LB
11	X51 20BR/YL
12	Z5 16BK
13	X56 20DB
14	X54 20VT/YL

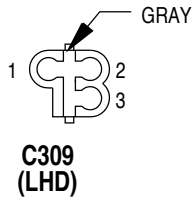
* GAS
** DIESEL



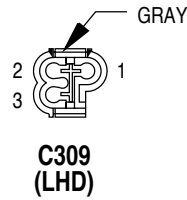
CAV	CIRCUIT
1	X82 16LB/RD
2	X80 16LB/DG
3	L61 18LG
3	L61 18LG
4	L60 18TN
4	L60 18TN
5	G46 20LB/BK
6	V13 18BR/LG
7	L36 18LG/OR
8	Z2 18BK/OR
9	K255 20WT/DG**
10	K151 20WT**
11	K6 20VT/WT**
12	K22 20OR/DB**
13	X85 16LG/BK
14	X87 16LG/RD



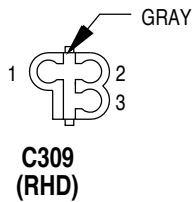
CAV	CIRCUIT
1	X82 20LB/RD
2	X80 20LB/BK
3	L61 18DG
4	L60 18TN
5	G46 20BK/LB
6	V13 18BR/LG
7	L36 18LG
8	Z2 18BK/OR
9	K255 20WT/DG**
10	K151 20WT**
11	K6 20VT/WT**
12	K22 20OR/DB**
13	X85 20LG/BK
14	X87 20LG/RD



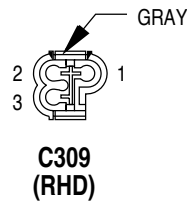
CAV	CIRCUIT
1	Q17 14DB/WT
2	Q27 14RD/BK
3	P34 14PK/BK



CAV	CIRCUIT
1	Q17 14DB/WT
2	Q27 14RD/BK
3	P34 14PK/BK

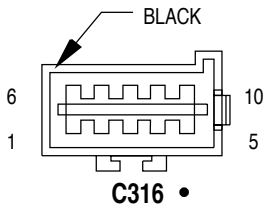


CAV	CIRCUIT
1	Q18 14GY/BK
2	Q28 14DG/WT
3	P34 14PK/BK

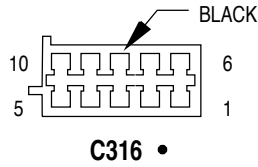


CAV	CIRCUIT
1	Q18 14GY/BK
2	Q28 14DG/WT
3	P34 14PK/BK

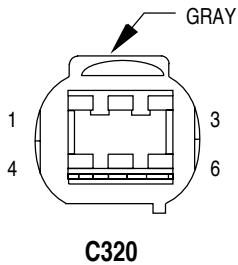
** DIESEL



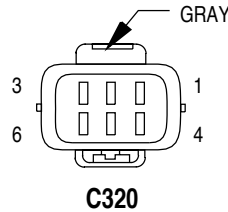
CAV	CIRCUIT
1	L36 18LG/OR
	L36 18LG/OR
2	L50 18WT/TN
3	L90 18DB/RD*
	L90 18DB/RD
4	L22 18LB
5	L21 18LB/WT
6	L74 18PK/BK
7	L73 18PK/WT
8	L87 18DG/WT
9	Z1 18BK
10	-



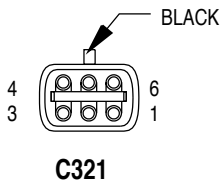
CAV	CIRCUIT
1	L36 18LG/OR
2	L50 18WT/TN
3	L90 18DB/RD
	L90 18DB/RD
4	L90 18DB/RD
	L90 18DB/RD
5	L90 18DB/RD
6	L50 18WT/TN
7	L50 18WT/TN
8	L50 18WT/TN
9	G46 20LB/BK
10	F87 18WT/PK



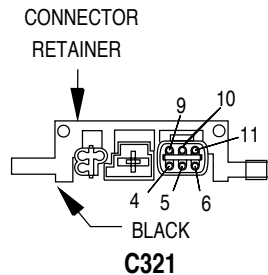
CAV	CIRCUIT
1	L74 18PK/BK
2	L22 18LB
3	L10 18BR/LG
4	Z1 18BK
5	L60 18TN
5	L60 18TN
6	L36 18LG/OR



CAV	CIRCUIT
1	L74 18PK/BK
2	L22 18LB
3	L10 18BR/LG
4	Z1 18BK
5	L61 18LG
6	L36 18LG/BK



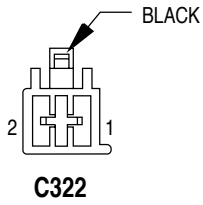
CAV	CIRCUIT
1	-
2	-
3	G71 20VT/YL
4	L90 18DB/RD
5	-
6	G78 20TN/BK



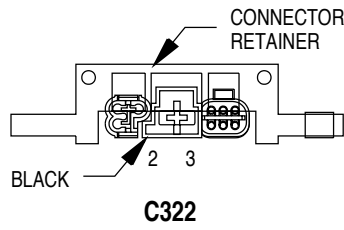
CAV	CIRCUIT
4	-
5	-
6	G71 20VT/YL
9	G78 16DB/RD
10	-
11	L90 20DB/RD

• WITHOUT LAMP OUTAGE MODULE, C1 AND C2 MATE TO MAKE C316

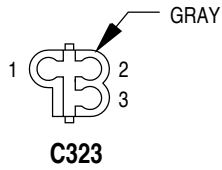
* OPTIONAL
** DIESEL



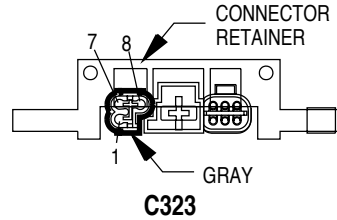
CAV	CIRCUIT
1	-
2	C15 12BK/WT



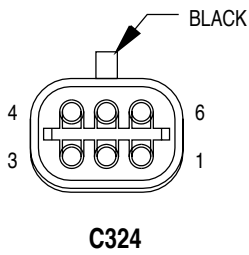
CAV	CIRCUIT
2	-
3	C15 12BK/LB



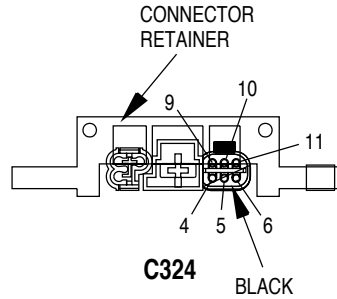
CAV	CIRCUIT
1	-
2	F70 14PK/BK
3	P2 14BKWT



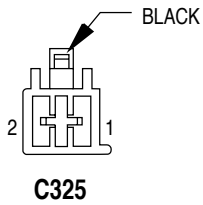
CAV	CIRCUIT
1	P2 16BK/WT
7	F70 16PK/BK
8	-



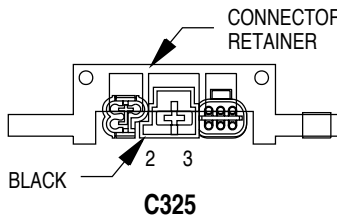
CAV	CIRCUIT
1	V13 18BR/LG
2	-
3	-
4	V20 18BK/WT
5	-
6	V24 18BR/OR



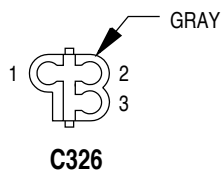
CAV	CIRCUIT
4	V13 18BR/LG
5	-
6	-
9	V24 18BR/OR
10	-
11	V20 18BK/WT



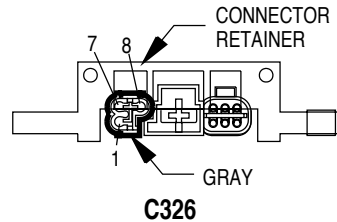
CAV	CIRCUIT
1	-
2	Z1 12BK



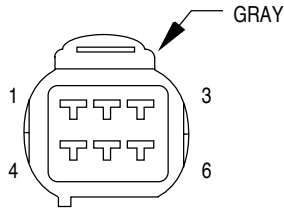
CAV	CIRCUIT
2	-
3	Z1 12BK



CAV	CIRCUIT
1	L87 18DG/WT
2	Z1 18BK
3	P34 14PK/BK

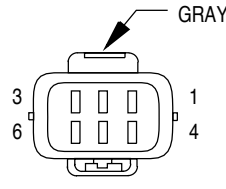


CAV	CIRCUIT
1	P34 16PK/BK
7	Z1 18BK
8	L87 18DG/WT



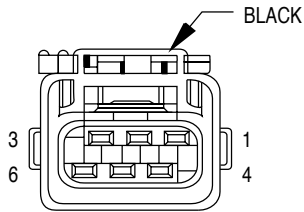
C328

CAV	CIRCUIT
1	L73 18PK/WT
2	L21 18LB/WT
3	L10 18BR/LG
4	Z1 18BK
5	L61 18LG
6	L36 18LG/OR



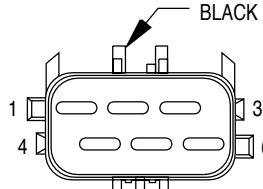
C328

CAV	CIRCUIT
1	L73 18PK/WT
2	L21 18LB/WT
3	L10 18BR/LG
4	Z1 18BK
5	L61 18LG
6	L36 18LG/BK



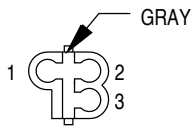
C329

CAV	CIRCUIT
1	F35 16RD
2	Z1 16BK
3	D1 18VT/BR
4	D2 18WT/BK
5	P7 18LB/BK
6	F71 18PK/DG



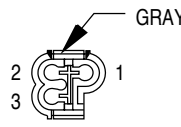
C329

CAV	CIRCUIT
1	F35 14RD
2	Z1 14BK
3	D1 20VT/BR
4	D2 20WT/BK
5	P7 18LB/BK
6	F87 18PK/DG



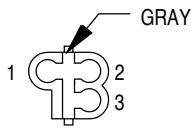
**C330
(LHD)**

CAV	CIRCUIT
1	Q18 14GY/BK
2	Q28 14DG/WT
3	P34 14PK/BK



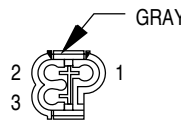
**C330
(LHD)**

CAV	CIRCUIT
1	Q18 14GY/BK
2	Q28 14DG/WT
3	P34 14PK/BK



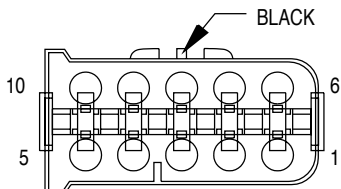
**C330
(RHD)**

CAV	CIRCUIT
1	Q17 14DB/WT
2	Q27 14RD/BK
3	P34 14PK/BK



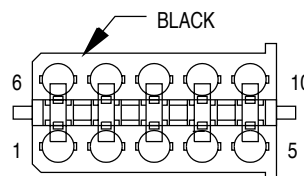
**C330
(RHD)**

CAV	CIRCUIT
1	Q17 14DB/WT
2	Q27 14RD/BK
3	P34 14PK/BK



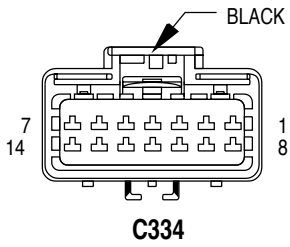
C331

CAV	CIRCUIT
1	-
2	L90 18DB/RD
3	L10 18BR/LG
4	L61 18LG/OR
5	L60 18TN/OR
6	F70 18PK/BK
7	-
8	B40 12LB
9	Z1 12BK
10	-

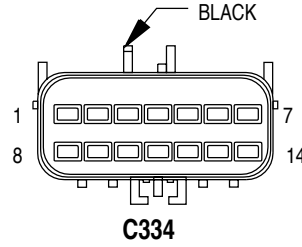


C331

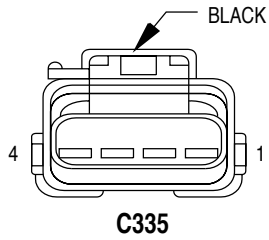
CAV	CIRCUIT
1	-
2	L90 18DB/RD
3	L10 18BR/LG
4	L61 18LG
5	L60 18TN
6	F70 18PK/BK
7	-
8	B40 12LB
9	Z1 12BK
10	-



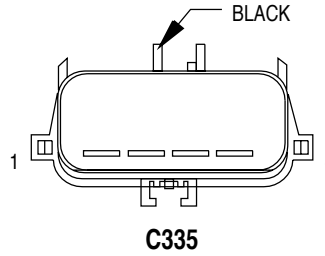
CAV	CIRCUIT
1	Z1 12BK
2	-
3	F81 12TN
4	E21 18OR/RD
5	Q17 14DB/WT
6	X53 16DG**
6	X87 16LG/RD*
7	Q27 14RD/BK
8	X55 16BR/RD**
8	X85 16LG/BK*
9	P114 18YL/BK
10	-
11	P112 18YL/WT
12	D2 18WT/BK
13	D1 18VT/BR
14	G71 20VT/YL



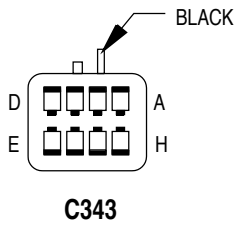
CAV	CIRCUIT
1	Z1 12BK
2	-
3	F81 12TN
4	E21 18OR
5	Q17 16DB/WT
6	X53 20DG
7	Q27 16RD/BK
8	X55 20BR/RD
9	P114 20YL/BK
10	-
11	P112 20YL/WT
12	D2 18WT/BK
13	D1 18VT/BR
14	G71 20VT/YL



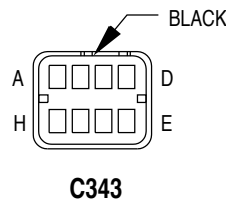
CAV	CIRCUIT
1	F35 16RD
2	Z1 16BK
3	P8 18LB/WT
4	F71 18PK/DG



CAV	CIRCUIT
1	F35 14RD
2	Z1 14BK
3	P8 18LB/WT
4	F87 18WT/BK

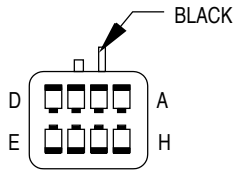


CAV	CIRCUIT
A	X93 16WT/RD*
A	X51 16BR/YL**
B	X91 16WT/BK*
B	X57 16BR/LB**
C	P2 16BK/WT
D	Z1 16BK
E	E21 18OR/RD



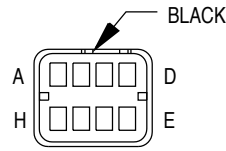
CAV	CIRCUIT
A	X52 20DB/WT
B	X58 20DB/OR
C	P2 18BK/WT
D	Z1 16BK
E	E21 20OR/RD

* PREMIUM RADIO
 ** STANDARD RADIO



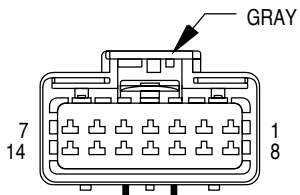
C345

CAV	CIRCUIT
A	X94 16TN/RD*
A	X52 16DB/WT**
B	X92 16TN/BK*
B	X58 16DB/OR**
C	P2 16BK/WT
D	Z1 16BK
E	E20 18OR/DB
F	-
G	-
H	-



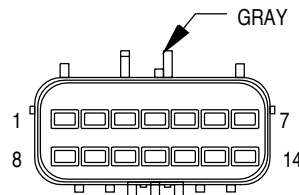
C345

CAV	CIRCUIT
A	X52 20DB/WT
B	X58 20DB/OR
C	P2 18BK/WT
D	Z1 16BK
E	E20 20OR/DG
F	-
G	-
H	-



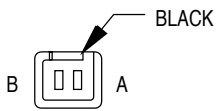
C351

CAV	CIRCUIT
1	Z1 12BK
2	-
3	F81 12TN
4	E20 18OR/DB
5	Q18 14GY/BK
6	X54 16VT**
6	X82 16LB/RD*
7	Q28 14DG/WT
8	X56 16DB**
8	X80 16LB/DG*
9	P2 14BK/WT
10	P34 14PK/BK
11	-
12	D2 18WT/BK
13	D1 18VT/BR
14	G71 20VT/YL



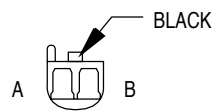
C351

CAV	CIRCUIT
1	Z1 12BK
2	-
3	F81 12TN
4	E20 18OR/DB
5	Q18 16GY/BK
6	X54 20VT
7	Q28 16DG/WT
8	X56 20DB/RD
9	P2 14BK/WT
10	P34 14PK/BK
11	-
12	D2 18WT/BK
13	D1 18VT/BR
14	G71 20VT/YL



C353

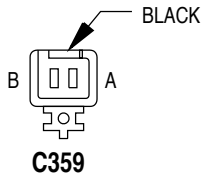
CAV	CIRCUIT
A	P114 20YL/BK
B	P112 20YL/WT



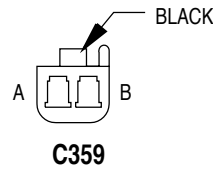
C353

CAV	CIRCUIT
A	P114 20YL/BK
B	P112 20YL/WT

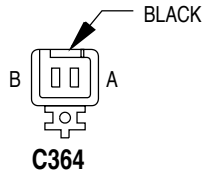
* PREMIUM RADIO
 ** STANDARD RADIO



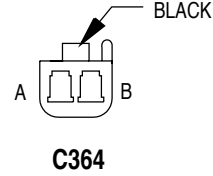
CAV	CIRCUIT
A	L87 18DG/WT
B	Z1 18BK



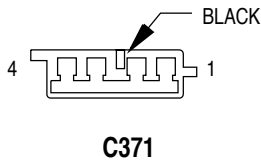
CAV	CIRCUIT
A	L87 20DG/WT
B	Z1 20BK



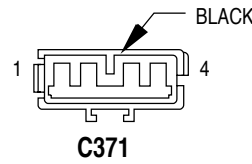
CAV	CIRCUIT
A	Z1 20BK
B	L90 20DB/RD



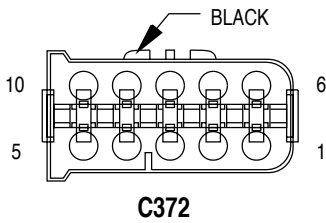
CAV	CIRCUIT
A	Z1 20BK
B	L90 20DB/RD



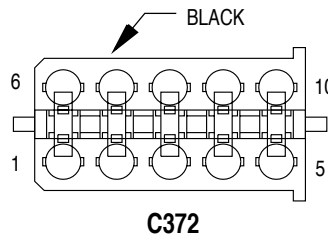
CAV	CIRCUIT
1	Z1 16BK
2	Q41 16WT
3	Q42 16LB
4	F86 16LG/BK



CAV	CIRCUIT
1	Z1 16BK
2	Q41 16WT
3	Q42 16LB
4	F86 16LG/BK

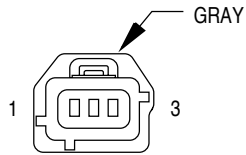


CAV	CIRCUIT
1	L50 18WT/TN
2	L90 18DB/RD
3	L10 18BR/LG
4	L61 18LG
	L61 18LG*
5	L60 18TN
	L60 18TN*
6	F70 16PK/BK
7	B40 12LB
8	Z1 12BK
9	-
10	-



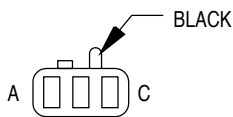
CAV	CIRCUIT
1	L50 18WT/TN
2	L90 18DB/RD
3	L10 18BR/LG
4	L61 18LG
5	L60 18TN
6	F70 16PK/BK
7	B40 12LB
8	Z1 12BK
9	-
10	-

* FACTORY TRAILER
TOW ONLY



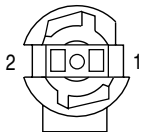
**CAMSHAFT
POSITION SENSOR
(GAS)**

CAV	CIRCUIT	FUNCTION
1	K25 20WT/BK	5-VOLT SUPPLY
1	K24 18GY/BK*	CAMSHAFT POSITION SENSOR SIGNAL
2	K4 20BK/LB	SENSOR GROUND
3	K25 20WT/BK*	5-VOLT SUPPLY
3	K24 18GY/BK	CAMSHAFT POSITION SENSOR SIGNAL



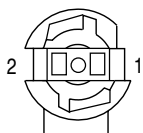
CARGO LAMP

CAV	CIRCUIT	FUNCTION
A	M2 20YL	COURTESY LAMP RELAY OUTPUT
B	M1 20PK	FUSED B(+)
C	M4 20WT/LG	LIFTGATE COURTESY LAMP DISABLE



**CENTER HIGH
MOUNTED STOP
LAMP NO. 1**

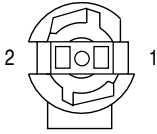
CAV	CIRCUIT	FUNCTION
1	L87 20DG/WT	STOP LAMP SWITCH OUTPUT
	L87 20DG/WT	STOP LAMP SWITCH OUTPUT
2	Z1 20BK	GROUND
	Z1 20BK	GROUND



**CENTER HIGH
MOUNTED STOP
LAMP NO. 2**

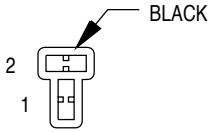
CAV	CIRCUIT	FUNCTION
1	L87 20DG/WT	STOP LAMP SWITCH OUTPUT
2	Z1 20BK	GROUND

*4.0L



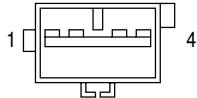
CENTER HIGH MOUNTED STOP LAMP NO. 3

CAV	CIRCUIT	FUNCTION
1	L87 20DG/WT	STOP LAMP SWITCH OUTPUT
	L87 20DG/WT	STOP LAMP SWITCH OUTPUT
2	Z1 20BK	GROUND
	Z1 20BK	GROUND



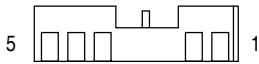
CIGAR LIGHTER (RHD)

CAV	CIRCUIT	FUNCTION
1	F30 18RD/DB	FUSED IGNITION SWITCH OUTPUT (RUN-ACC)
2	Z1 18BK	GROUND



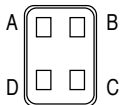
CIGAR LIGHTER/POWER OUTLET (LHD)

CAV	CIRCUIT	FUNCTION
1	F38 18OR	FUSED B(+)
2	Z1 16BK	GROUND
3	E2 18OR/RD	FUSED PANEL LAMPS DIMMER SWITCH SIGNAL
4	F30 18RD/DB	FUSED IGNITION SWITCH OUTPUT (RUN-ACC)



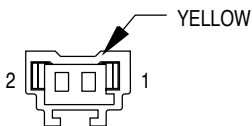
CLOCKSPRING - C1

CAV	CIRCUIT	FUNCTION
1	K95 20PK	VEHICLE SPEED CONTROL SWITCH SIGNAL
2	K4 18BK/LB	SENSOR GROUND
3	709 20RD/BK	RADIO CONTROL MUX
4	Z2 20BK/OR	GROUND
5	X4 20GY/OR	HORN RELAY CONTROL



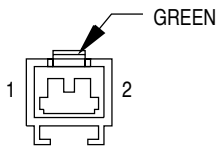
CLOCKSPRING - C2

CAV	CIRCUIT	FUNCTION
A	K95 20PK	VEHICLE SPEED CONTROL SWITCH SIGNAL
B	K4 20BK/LB	SENSOR GROUND
C	709 20RD/BK	RADIO CONTROL MUX
D	Z2 20BK/LG	GROUND

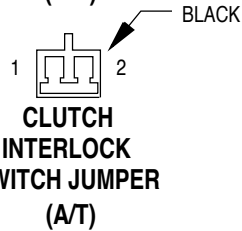


CLOCKSPRING - C3

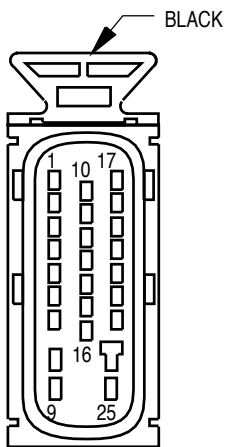
CAV	CIRCUIT	FUNCTION
1	R45 18DG/LB	DRIVER AIR BAG LINE 2
2	R43 18BK/LB	DRIVER AIR BAG LINE 1



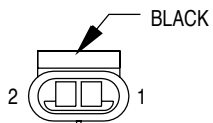
CLUTCH INTERLOCK SWITCH (M/T)



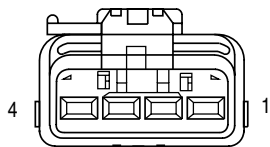
CLUTCH INTERLOCK SWITCH JUMPER (A/T)



CONTROLLER ANTI-LOCK BRAKE



COOLANT LEVEL SENSOR



COOLING FAN MOTOR (MAX COOLING)

CAV	CIRCUIT	FUNCTION
1	T141 14YL/RD	CLUTCH INTERLOCK SWITCH SENSE
2	A41 14YL	IGNITION SWITCH OUTPUT START

CAV	CIRCUIT	FUNCTION
1	T141 14YL/RD	
2	T141 14YL/RD	

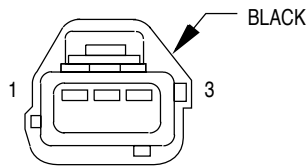
CAV	CIRCUIT	FUNCTION
1	B1 18YL/DB	RIGHT REAR WHEEL SPEED SENSOR (-)
2	B3 18LG/DB	LEFT REAR WHEEL SPEED SENSOR (-)
3	B7 18WT	RIGHT FRONT WHEEL SPEED SENSOR (+)
4	B9 18RD	LEFT FRONT WHEEL SPEED SENSOR (+)
5	-	-
6	B41 18YL/VT	G SWITCH NO. 1 SENSE
7	B42 18TN/WT	G SWITCH NO. 2 SENSE
8	Z2 12BK	GROUND
9	A20 14RD/LG	FUSED B(+)
10	B4 18LG	LEFT REAR WHEEL SPEED SENSOR (+)
11	B8 18RD/DB	LEFT FRONT WHEEL SPEED SENSOR (-)
12	L50 18WT/TN	BRAKE LAMP SWITCH OUTPUT
13	B43 18PK/OR	G SWITCH TEST SIGNAL
14	-	-
15	-	-
16	G19 18GY/BK*	ABS WARNING LAMP DRIVER
16	205 18WT/VT**	ABS WARNING LAMP DRIVER
17	B2 18YL	RIGHT REAR WHEEL SPEED SENSOR (+)
18	B6 18WT/DB	RIGHT FRONT WHEEL SPEED SENSOR (-)
19	-	-
20	D21 18BK/PK	SCI RECEIVE
20	D83 18BK/PK**	SCI RECEIVE
21	-	-
22	-	-
23	F12 18DB/WT*	FUSED IGNITION SWITCH OUTPUT (RUN)
23	F12 20DB/WT**	FUSED IGNITION SWITCH OUTPUT (RUN)
24	Z2 12BK	GROUND
25	A10 12RD/DB	FUSED B(+)

CAV	CIRCUIT	FUNCTION
1	G18 20PK/BK**	ENGINE COOLANT LEVEL SENSE
1	G18 16PK/BK*	ENGINE COOLANT LEVEL SENSE
2	K167 20BR/YL**	SENSOR RETURN
2	Z1 16BK*	GROUND

CAV	CIRCUIT	FUNCTION
1	C25 10RD/WT	HIGH SPEED RADIATOR FAN OUTPUT
2	-	-
3	C23 10DG	LOW SPEED RADIATOR FAN OUTPUT
4	Z1 10BK	GROUND

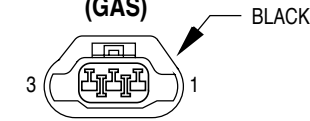
* GAS

** DIESEL



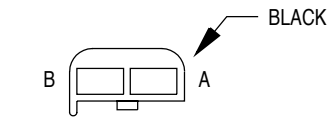
CRANKSHAFT POSITION SENSOR (GAS)

CAV	CIRCUIT	FUNCTION
1	K27 18RD/LG	CRANKSHAFT POSITION SENSOR SIGNAL
2	K4 20BK/LB	SENSOR GROUND
3	K25 20WT/BK	5-VOLT SUPPLY



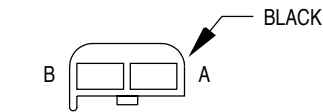
CRANKSHAFT POSITION SENSOR (DIESEL)

CAV	CIRCUIT	FUNCTION
1	Z3 20BK/OR	GROUND
2	-	-
3	K24 20GY/BK	CRANKSHAFT POSITION SENSOR SIGNAL



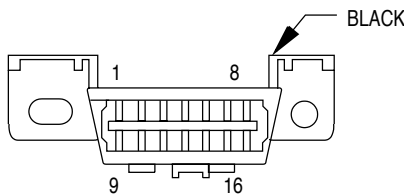
CRUISE SWITCH NO. 1

CAV	CIRCUIT	FUNCTION
A	K95 20PK	VEHICLE SPEED CONTROL SWITCH SIGNAL
B	K4 20BK/LB	SENSOR GROUND



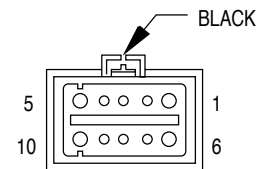
CRUISE SWITCH NO. 2

CAV	CIRCUIT	FUNCTION
A	K95 20PK	VEHICLE SPEED CONTROL SWITCH SIGNAL
B	K4 20BK/LB	SENSOR GROUND



DATA LINK CONNECTOR

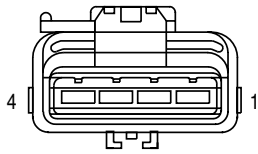
CAV	CIRCUIT	FUNCTION
1	-	-
2	-	-
3	D1 18VT/BR	CCD BUS(+)
4	Z1 18BK	GROUND
5	Z2 18BK/OR	GROUND
6	D84 20BK/WT	SCI TRANSMIT
7	D83 20BK/PK	SCI RECIEVE
8	-	-
9	-	-
10	-	-
11	D2 18WT/BK	CCD BUS (-)
12	D98 20WT*	SCI TRANSMIT
13	-	-
14	-	-
15	-	-
16	F75 18VT	FUSED B(+)



DAYTIME RUNNING LAMP MODULE

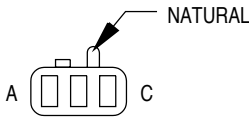
CAV	CIRCUIT	FUNCTION
1	L3 16RD/OR	DIMMER SWITCH HIGH BEAM OUTPUT
2	-	-
3	G9 20GY/BK	RED BRAKE WARNING LAMP DRIVER
4	G34 20RD/GY	HIGH BEAM INDICATOR DRIVER
5	F83 20YL/DG	FUSED IGNITION SWITCH OUTPUT (RUN)
6	A6 14RD/LB	FUSED B(+)
7	-	-
8	Z4 16BK	HVAC GROUND
9	Z4 20BK	HVAC GROUND
10	L4 16VT/OR	LOW BEAM RELAY OUTPUT

* LHD



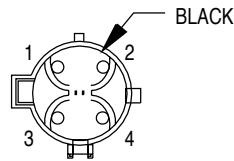
DIAGNOSTIC CONNECTOR (MAX COOLING)

CAV	CIRCUIT	FUNCTION
1	F143 16LG/RD	FUSED B(+)
1	F99 16OR*	FUSED B(+)
2	Z1 16BK	GROUND
3	C29 16TN	IGNITION RELAY
4	C4 16TN/BK	LOW SPEED COOLING FAN RELAY



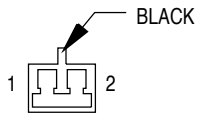
DOME/READING LAMP

CAV	CIRCUIT	FUNCTION
A	Z1 20BK	GROUND
B	M2 20YL	COURTESY LAMP RELAY OUTPUT
C	M1 20PK	FUSED B(+)



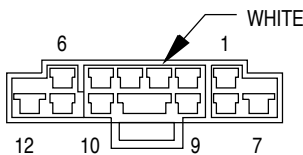
DOWNSTREAM HEATED OXYGEN SENSOR

CAV	CIRCUIT	FUNCTION
1	A142 18DG/OR	AUTOMATIC SHUT DOWN RELAY OUTPUT
2	Z12 18BK/TN	GROUND
3	K4 18BK/LB	SENSOR GROUND
4	K141 18BK/PK	DOWNSTREAM HEATED OXYGEN SENSOR SIGNAL



DRIVER DOOR COURTESY LAMP

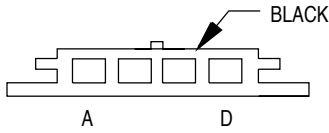
CAV	CIRCUIT	FUNCTION
1	M1 20PK	FUSED B(+)
2	Z1 20BK	GROUND



DRIVER DOOR MODULE - C1

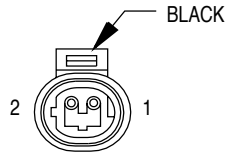
CAV	CIRCUIT	FUNCTION
1	Q11 16LB	LEFT FRONT WINDOW DRIVER (UP)
2	Q21 16WT	LEFT FRONT WINDOW DRIVER (DOWN)
3	Q17 16DB/WT	LEFT REAR WINDOW DRIVER (UP)
4	Q27 16RD/BK	LEFT REAR WINDOW DRIVER (DOWN)
5	P34 18PK/BK	LEFT FRONT DOOR UNLOCK DRIVER
6	P35 18OR/VT	LEFT FRONT DOOR LOCK DRIVER
7	Z1 12BK	GROUND
8	D1 18VT/BR	CCD BUS (+)
9	D2 18WT/BK	CCD BUS (-)
10	E21 18OR	LEFT REAR DOOR SWITCH ILLUMINATION
11	M1 20PK	MUX COURTESY LAMP DRIVER
12	F81 12TN	FUSED B(+)

* 4.0L



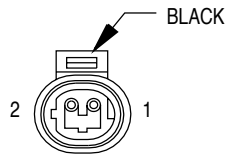
**DRIVER DOOR
MODULE - C2**

CAV	CIRCUIT	FUNCTION
A	Z1 20BK	GROUND
B	P22 20BR	5 VOLT SUPPLY
C	G49 20OR	SET LED DRIVER
D	M1 20GY	SWITCHED MUX LED SUPPLY



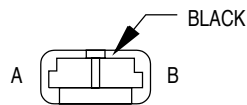
**DRIVER FRONT
CYLINDER
LOCK SWITCH**

CAV	CIRCUIT	FUNCTION
1	G71 20VT/YL	VTSS DISARM SENSE
2	Z1 20BK	GROUND



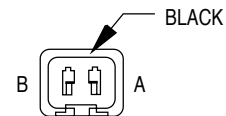
**DRIVER FRONT
DOOR LOCK
MOTOR**

CAV	CIRCUIT	FUNCTION
1	P34 18PK/BK	LEFT FRONT DOOR UNLOCK DRIVER
2	P35 18OR/VT	LEFT FRONT DOOR LOCK DRIVER



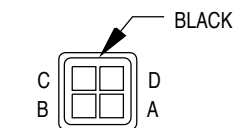
**DRIVER FRONT
DOOR SPEAKER**

CAV	CIRCUIT	FUNCTION
A	X53 20DG	LEFT FRONT (+)
B	X55 20BR/RD	LEFT FRONT (-)



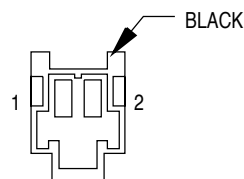
**DRIVER HEATED
SEAT BACK**

CAV	CIRCUIT	FUNCTION
A	Z1 16BK	GROUND
B	P88 16BR/BK	HEATED SEAT DRIVER



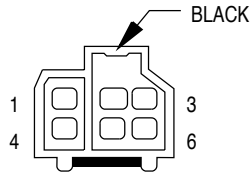
**DRIVER HEATED
SEAT CUSHION**

CAV	CIRCUIT	FUNCTION
A	P87 16BK/OR	HEATED SEAT DRIVER
B	P88 16BR/BK	HEATED SEAT DRIVER
C	P7 18LB/BK	DRIVER HEATED SEAT SWITCH OUTPUT
D	Z1 20BK	GROUND



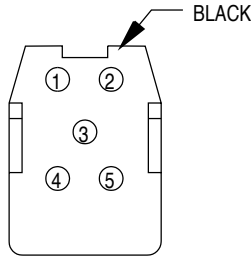
**DRIVER LUMBAR
MOTOR**

CAV	CIRCUIT	FUNCTION
1	P106 18DG/WT	LUMBAR FORWARD DRIVER
2	P107 18OR/BK	LUMBAR REARWARD DRIVER



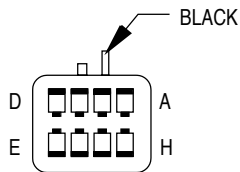
**DRIVER LUMBAR
SENSOR/MOTOR**

CAV	CIRCUIT	FUNCTION
1	P106 16DG/WT	LUMBAR REARWARD DRIVER
2	P107 16OR/BK	LUMBAR FORWARD DRIVER
3	P28 20BR/RD	SENSOR GROUND
4	P103 20DB/WT	LUMBAR POSITION SENSE
5	P29 20BR/WT	6-VOLT SENSOR SUPPLY



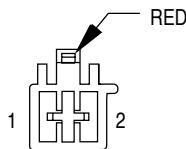
**DRIVER LUMBAR
SWITCH**

CAV	CIRCUIT	FUNCTION
1	P104 20YL/RD*	LUMBAR REARWARD SWITCH SENSE
1	P107 18OR/BK	LUMBAR FORWARD DRIVER
2	Z1 18BK	GROUND
3	F35 18RD	FUSED B(+)
4	Z1 18BK	GROUND LUMBAR FORWARD SWITCH SENSE
5	P105 20LG/DB*	LUMBAR FORWARD SWITCH SENSE
5	P106 18DG/WT	LUMBAR REARWARD DRIVER



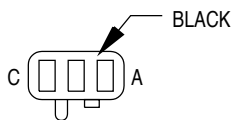
**DRIVER OUTSIDE
POWER MIRROR**

CAV	CIRCUIT	FUNCTION
A	F75 20YL	HORIZONTAL DRIVER
B	Z1 20BK	HEATER SWITCHED GROUND
C	F84 20VT	VERTICAL POSITION SENSOR SIGNAL
D	F86 20GY	SENSOR GROUND
E	F85 20GN	HORIZONTAL POSITION SENSOR SIGNAL
F	C16 20BK	HEATER 12-VOLT SUPPLY
G	F73 20DB	COMMON DRIVER
H	F71 20WT	VERTICAL DRIVER



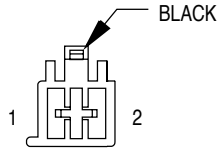
**DRIVER POWER
SEAT FRONT
RISER MOTOR**

CAV	CIRCUIT	FUNCTION
1	P121 16RD/GY*	FRONT RISER DOWN DRIVER
	P21 16RD/LG	FRONT RISER DOWN SWITCH SENSE
2	P119 16YL/RD*	FRONT RISER UP DRIVER
	P19 16YL/LG	FRONT RISER UP SWITCH SENSE



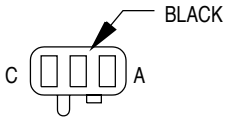
**DRIVER POWER
SEAT FRONT
RISER MOTOR
SENSOR (MEMORY)**

CAV	CIRCUIT	FUNCTION
A	P28 20BR/RD	SENSOR GROUND
B	P26 20BR	FRONT RISER POSITION SENSE
C	P29 20BR/WT	6-VOLT SENSOR SUPPLY



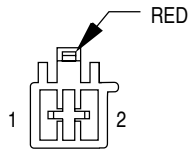
**DRIVER POWER
SEAT HORIZONTAL
MOTOR**

CAV	CIRCUIT	FUNCTION
1	P115 16GY/LG*	HORIZONTAL FORWARD DRIVER
1	P15 16YL/LB	HORIZONTAL FORWARD SWITCH SENSE
2	P117 16RD/BR*	HORIZONTAL REARWARD DRIVER
2	P17 16RD/LB	HORIZONTAL REARWARD SWITCH SENSE



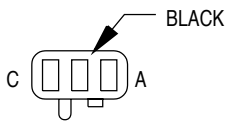
**DRIVER POWER
SEAT HORIZONTAL
MOTOR SENSOR
(MEMORY)**

CAV	CIRCUIT	FUNCTION
A	P29 20BR/WT	6-VOLT SENSOR SUPPLY
B	P25 20VT/RD	HORIZONTAL POSITION SENSE
C	P28 20BR/RD	SENSOR GROUND



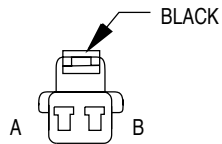
**DRIVER POWER
SEAT REAR
RISER MOTOR**

CAV	CIRCUIT	FUNCTION
1	P113 16RD/BK*	REAR RISER DOWN DRIVER
	P13 16RD/WT	REAR RISER DOWN SWITCH SENSE
2	P111 16YL/DB*	REAR RISER UP DRIVER
	P11 16YL/WT	REAR RISER UP SWITCH SENSE



**DRIVER POWER
SEAT REAR
RISER MOTOR
SENSOR (MEMORY)**

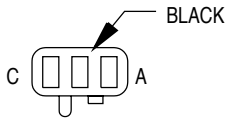
CAV	CIRCUIT	FUNCTION
A	P28 20BR/RD	SENSOR GROUND
B	P27 20LB/RD	REAR RISER POSITION SENSE
C	P29 20BR/WT	6-VOLT SENSOR SUPPLY



**DRIVER POWER
SEAT RECLINER
MOTOR**

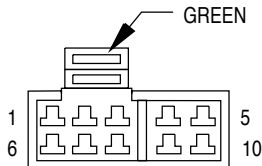
CAV	CIRCUIT	FUNCTION
A	P41 16GY/WT	RECLINER DOWN DRIVER
B	P43 16GY/LB	RECLINER DOWN DRIVER

* MEMORY SEATS



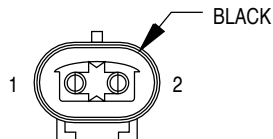
DRIVER POWER SEAT RECLINER MOTOR SENSOR (MEMORY)

CAV	CIRCUIT	FUNCTION
A	P29 20BR/WT	6-VOLT SENSOR SUPPLY
B	P47 20LB	HORIZONTAL POSITION SENSE
C	P28 20BR/RD	SENSOR GROUND



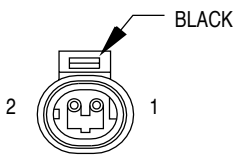
DRIVER POWER SEAT SWITCH

CAV	CIRCUIT	FUNCTION
1	Z1 16BK	GROUND
2	P40 18GY/LB*	RECLINER UP SWITCH SENSE
2	P43 16GY/LB	RECLINER UP DRIVER
3	P17 18RD/LB*	HORIZONTAL REARWARD SWITCH SENSE
3	P17 16RD/LB	HORIZONTAL REARWARD SWITCH SENSE
4	P48 18GY/WT*	RECLINER DOWN SWITCH SENSE
4	P41 16GY/WT	RECLINER DOWN DRIVER
5	F35 16RD	FUSED B(+)
6	P15 18YL/LB*	HORIZONTAL FORWARD SWITCH SENSE
6	P15 16YL/LB	HORIZONTAL FORWARD SWITCH SENSE
7	P19 18YL/LG*	FRONT RISER UP SWITCH SENSE
7	P19 16YL/LG	FRONT RISER UP SWITCH SENSE
•7	P21 18RD/LG*	FRONT RISER DOWN SWITCH SENSE
•7	P21 16RD/LG	FRONT RISER DOWN SWITCH SENSE
8	P11 18YL/WT*	REAR RISER UP SWITCH SENSE
8	P11 16YL/WT	REAR RISER UP SWITCH SENSE
•8	P13 18RD/WT*	REAR RISER DOWN SWITCH SENSE
•8	P13 16RD/WT	REAR RISER DOWN SWITCH SENSE
9	P13 18RD/WT*	REAR RISER DOWN SWITCH SENSE
9	P13 16RD/WT	REAR RISER DOWN SWITCH SENSE
•9	P11 18YL/WT*	REAR RISER UP SWITCH SENSE
•9	P11 16YL/WT	REAR RISER UP SWITCH SENSE
10	P21 18RD/LG*	FRONT RISER DOWN SWITCH SENSE
10	P21 16RD/LG	FRONT RISER DOWN SWITCH SENSE
•10	P19 18YL/LG*	FRONT RISER UP SWITCH SENSE
•10	P19 16YL/LG	FRONT RISER UP SWITCH SENSE



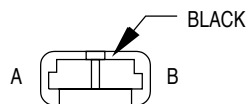
DRIVER POWER WINDOW MOTOR

CAV	CIRCUIT	FUNCTION
1	Q11 16LB	LEFT FRONT WINDOW DRIVER (UP)
2	Q21 16WT	LEFT FRONT WINDOW DRIVER (DOWN)



DRIVER REAR DOOR LOCK MOTOR

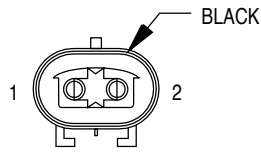
CAV	CIRCUIT	FUNCTION
1	P34 18PK/BK	DOOR UNLOCK DRIVER
2	P2 18BK/WT	DOOR LOCK DRIVER



DRIVER REAR DOOR SPEAKER

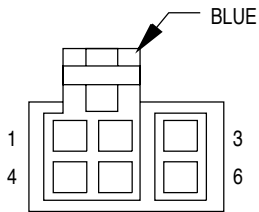
CAV	CIRCUIT	FUNCTION
A	X52 20DB/WT	LEFT REAR (+)
B	X58 20DB/OR	LEFT REAR (-)

* MEMORY SEATS
• RHD



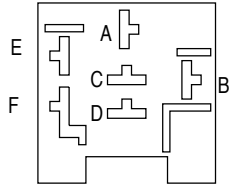
**DRIVER REAR
POWER WINDOW
MOTOR**

CAV	CIRCUIT	FUNCTION
1	Q12 16BR	LEFT REAR WINDOW DRIVER (UP)
2	Q22 16VT	LEFT REAR WINDOW DRIVER (DOWN)



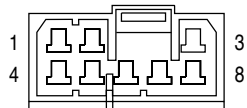
**DRIVER REAR
POWER WINDOW
SWITCH**

CAV	CIRCUIT	FUNCTION
1	Q17 14DB/WT	LEFT REAR WINDOW DRIVER (UP)
2	Q12 16BR	LEFT REAR WINDOW DRIVER (UP)
3	E21 20OR/DG	LEFT REAR DOOR SWITCH ILLUMINATION
4	Q27 14RD/BK	LEFT REAR WINDOW DRIVER (DOWN)
5	Q22 16VT	LEFT REAR WINDOW DRIVER (DOWN)
6	Z1 16BK	GROUND



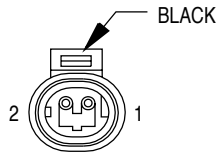
**DRIVER SEAT
HEATER CONTROL
MODULE (LHD)**

CAV	CIRCUIT	FUNCTION
A	P87 16BK/OR	HEATED SEAT DRIVER
B	-	-
C	F87 18PK/DG	FUSED IGNITION SWITCH OUTPUT (RUN)
D	F35 16RD	FUSED B(+)
E	P7 18LB/BK	DRIVER HEATED SEAT SWITCH OUTPUT
F	Z1 16BK	GROUND
G	-	-
H	-	-



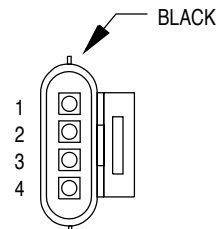
**DRIVER SEAT
HEATER CONTROL
MODULE (RHD)**

CAV	CIRCUIT	FUNCTION
1	F87 18PK/DG	FUSED IGNITION SWITCH OUTPUT (RUN)
2	F35 16RD	FUSED B(+)
3	P87 16BK/OR	HEATED SEAT DRIVER
4	-	-
5	-	-
6	-	-
7	Z1 16BK	GROUND
8	P7 18LB/BK	DRIVER HEATED SEAT SWITCH OUTPUT



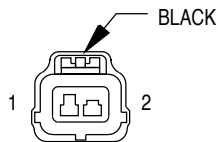
**DUTY CYCLE
EVAP/PURGE
SOLENOID**

CAV	CIRCUIT	FUNCTION
1	F99 20OR	IGNITION SWITCH OUTPUT (ST-RUN)
2	K52 18PK/BK	EVAPORATIVE EMISSION SOLENOID CONTROL



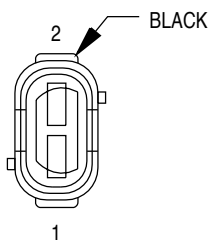
**ELECTRONIC
VACUUM
MODULATOR
(DIESEL)**

CAV	CIRCUIT	FUNCTION
1	A142 16DG/OR	AUTO SHUTDOWN RELAY OUTPUT
2	K35 16GY/YL	EGR SOLENOID CONTROL
4	Z1 18BK	GROUND



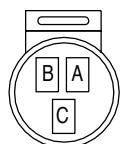
**ENGINE COOLANT
TEMPERATURE
SENSOR (4.0L)**

CAV	CIRCUIT	FUNCTION
1	K2 16TN/BK	ENGINE COOLANT TEMPERATURE SENSOR SIGNAL
2	K4 16BK/LB	SENSOR GROUND



**ENGINE COOLANT
TEMPERATURE
SENSOR (5.2L/5.9L)**

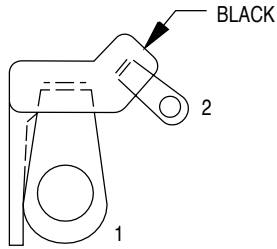
CAV	CIRCUIT	FUNCTION
1	K2 16TN/BK	ENGINE COOLANT TEMPERATURE SENSOR SIGNAL
2	K4 16BK/LB	SENSOR GROUND



**ENGINE COOLANT
TEMPERATURE
SENSOR (DIESEL)**

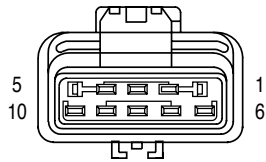
CAV	CIRCUIT	FUNCTION
A	K2 20TN/BK	ENGINE COOLANT TEMPERATURE SENSOR SIGNAL
B	K4 20BK/LB	SENSOR GROUND
C	K222 20TN/RD	SECONDARY ENGINE COOLANT TEMPERATURE SENSOR

** DIESEL



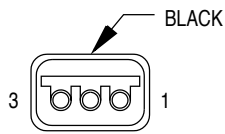
ENGINE STARTER MOTOR

CAV	CIRCUIT	FUNCTION
1	A0 6RD*	B(+)
1	A0 20RD**	B(+)
2	T40 12LG/BK*	ENGINE STARTER MOTOR RELAY OUTPUT
2	T40 14LG/BK**	ENGINE STARTER MOTOR RELAY OUTPUT



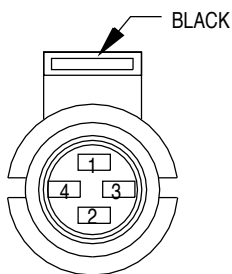
FACTORY TRAILER TOW CONNECTOR

CAV	CIRCUIT	FUNCTION
1	-	-
2	L60 18TN	RIGHT TURN SIGNAL
3	L10 18BR/LG	BACK-UP LAMP SWITCH OUTPUT
4	F70 18PK/BK	FUSED B(+)
5	L90 18DB/RD	PARK LAMP RELAY OUTPUT
6	-	-
7	B40 14LB	TRAILER TOW OUTPUT
8	Z1 14BK	GROUND
9	-	-
10	L61 18LG	LEFT TURN SIGNAL



FLOOR CONSOLE LAMPS

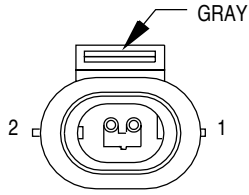
CAV	CIRCUIT	FUNCTION
1	Z1 20BK	GROUND
2	-	-
3	E2 18OR	PANEL LAMP DRIVER



FOUR WHEEL DRIVE SWITCH

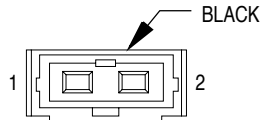
CAV	CIRCUIT	FUNCTION
1	Z12 20BK/TN*	POWER GROUND
1	Z1 20BK**	GROUND
2	T106 20GY/OR	-
3	G28 20LG/OR	TRANSMISSION TEMPERATURE LAMP DRIVER
4	T107 20BK/RD	-

* GAS
** DIESEL



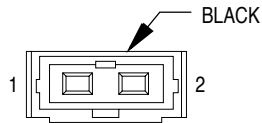
**FUEL HEATER
(DIESEL)**

CAV	CIRCUIT	FUNCTION
1	A64 14DG/WT	ELECTRIC PUMP FEED
2	Z1 14BK	GROUND



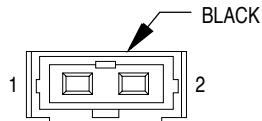
**FUEL INJECTOR
NO. 1**

CAV	CIRCUIT	FUNCTION
1	A142 18DG/OR	AUTOMATIC SHUT DOWN RELAY OUTPUT
2	K11 18WT/DB	INJECTOR NO.1 DRIVER



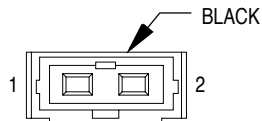
**FUEL INJECTOR
NO. 2**

CAV	CIRCUIT	FUNCTION
1	A142 18DG/OR	AUTOMATIC SHUT DOWN RELAY OUTPUT
2	K12 18TN	INJECTOR NO. 2 DRIVER



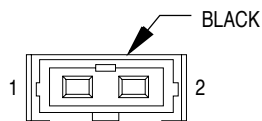
**FUEL INJECTOR
NO. 3**

CAV	CIRCUIT	FUNCTION
1	A142 18DG/OR	AUTOMATIC SHUT DOWN RELAY OUTPUT
2	K13 18YL/WT	INJECTOR NO. 3 DRIVER



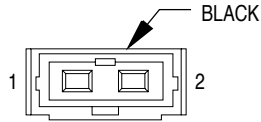
**FUEL INJECTOR
NO. 4**

CAV	CIRCUIT	FUNCTION
1	A142 18DG/OR	AUTOMATIC SHUT DOWN RELAY OUTPUT
2	K14 18LB/BR	INJECTOR NO. 4 DRIVER



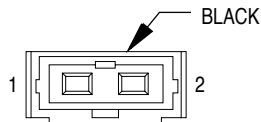
**FUEL INJECTOR
NO. 5**

CAV	CIRCUIT	FUNCTION
1	A142 18DG/OR	AUTOMATIC SHUT DOWN RELAY OUTPUT
2	K38 18GY	INJECTOR NO. 5 DRIVER



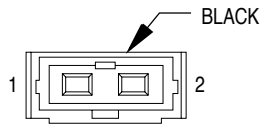
**FUEL INJECTOR
NO. 6**

CAV	CIRCUIT	FUNCTION
1	A142 18DG/OR	AUTOMATIC SHUT DOWN RELAY OUTPUT
2	K58 18BR/YL	INJECTOR NO. 6 DRIVER



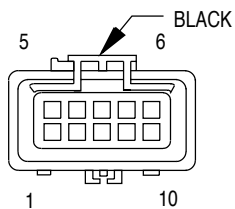
**FUEL INJECTOR
NO. 7
(5.2L/5.9L)**

CAV	CIRCUIT	FUNCTION
1	A142 18DG/OR	AUTOMATIC SHUT DOWN RELAY OUTPUT
2	K17 18DB/WT	INJECTOR NO. 7 DRIVER



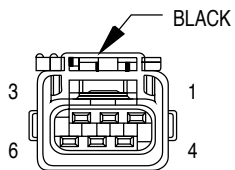
**FUEL INJECTOR
NO. 8
(5.2L/5.9L)**

CAV	CIRCUIT	FUNCTION
1	A142 18DG/OR	AUTOMATIC SHUT DOWN RELAY OUTPUT
2	K18 18DB/YL	INJECTOR NO. 8 DRIVER



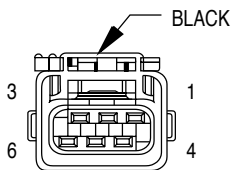
**FUEL PUMP
MODULE (DIESEL)**

CAV	CIRCUIT	FUNCTION
1	K134 20LB/BK	SLEEVE POSITION SENSOR (-)
2	K57 20LG/OR	CONT SLEEVE POSITION SENSOR
3	K135 20WT/BK	SLEEVE POSITION SENSOR (+)
4	K4 20BK/LB	SENSOR GROUND
5	K238 16VT	FUEL TIMING SHUTOFF SOLENOID
6	K153 20OR	SHUTOFF FEED
7	K156 20GY	FUEL TEMP SENSOR SIGNAL
8	K140 14TN/WT	FUEL QUANTITY ACTUATOR GROUND
9	A142 14DG/OR	AUTOMATIC SHUT DOWN RELAY OUTPUT
10	A142 16DG/OR	AUTOMATIC SHUT DOWN RELAY OUTPUT



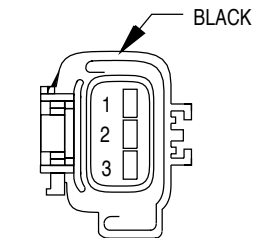
**FUEL PUMP
MODULE (GAS)**

CAV	CIRCUIT	FUNCTION
1	A64 16DG/WT	FUEL PUMP RELAY OUTPUT
2	-	-
3	G40 20LB/BK	LOW
4	K167 20BR/YL	SENSOR RETURN
5	-	-
6	Z1 16BK	GROUND



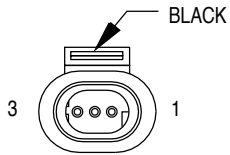
**FUEL SENDER
UNIT (DIESEL)**

CAV	CIRCUIT	FUNCTION
1	A64 16DG/WT	FUEL PUMP RELAY OUTPUT
2	-	-
3	G40 20LB/BK	LOW
4	K167 20BR/YL	SENSOR RETURN
5	-	-
6	Z1 16BK	GROUND



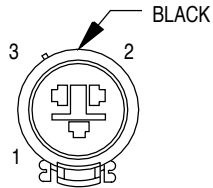
**FUEL TIMING
SOLENOID (DIESEL)**

CAV	CIRCUIT	FUNCTION
1	A142 16DG/BK	AUTOMATIC SHUTDOWN RELAY OUTPUT
2	D238 16VT	FUEL TIMING SHUTOFF SOLENOID
3	K153 20OR	SHUTOFF (+)



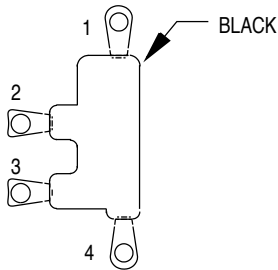
G-SWITCH

CAV	CIRCUIT	FUNCTION
1	B43 20PK/OR	G SWITCH GROUND
2	B41 20YL/VT	G SWITCH NO. 1 SENSE
3	B42 20TN/WT	G SWITCH NO. 2 SENSE



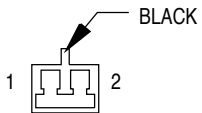
GENERATOR (DIESEL)

CAV	CIRCUIT	FUNCTION
1	A142 16DG/OR	AUTOMATIC SHUT DOWN RELAY OUTPUT
2	-	-
3	K20 18DG/YL	GENERATOR FIELD DRIVER



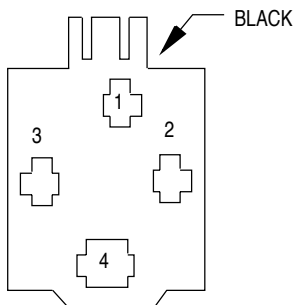
GENERATOR (GAS)

CAV	CIRCUIT	FUNCTION
1	Z0 8BK	GROUND
2	K72 18DG/VT	GENERATOR DRIVER
3	K20 18DG	GENERATOR FIELD DRIVER
4	-	-



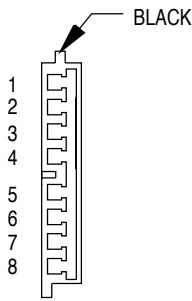
GLOVE BOX LAMP

CAV	CIRCUIT	FUNCTION
1	M1 20PK	FUSED B(+)
2	Z1 20BK	GROUND



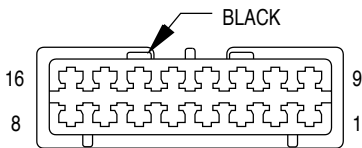
GLOW PLUG RELAY (DIESEL)

CAV	CIRCUIT	FUNCTION
1	A0 10RD	BATTERY POSITIVE
2	K152 16WT	GLOW PLUG RELAY CONTROL SENSE
3	A142 16DG/OR	AUTOMATIC SHUT DOWN RELAY OUTPUT
4	K154 10GY	GLOW PLUG RELAY CONTROL



**HEADLAMP LEVELING SWITCH
(BUILT-UP-EXPORT)**

CAV	CIRCUIT	FUNCTION
1	Z1 20BK	GROUND
2	L106 20YL	HEADLAMP LEVELING POSITION 6
3	L103 20LB	HEADLAMP LEVELING POSITION 3
4	L104 20LG	HEADLAMP LEVELING POSITION 4
5	F83 18YL/DG	FUSED IGNITION SWITCH OUTPUT (RUN)
6	L101 20RD	HEADLAMP LEVELING POSITION 1
7	L102 20WT	HEADLAMP LEVELING POSITION 2
8	L105 20PK	HEADLAMP LEVELING POSITION 5



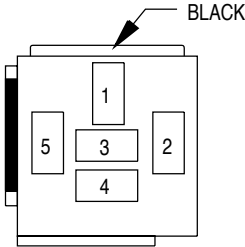
HEADLAMP SWITCH

CAV	CIRCUIT	FUNCTION
1	E2 20OR	PANEL LAMP DRIVER
2	Z1 16BK	GROUND
3	M11 20PK/LB	SWITCHED COURTESY LAMP FEED
4	L39 20LB	FOG LAMP RELAY OUTPUT
5	Z1 16BK	GROUND
6	L35 20BR/WT	FOG LAMP SWITCH OUTPUT
7	L96 20LG/RD	REAR FOG LAMP SWITCH GROUND
8	707 20BK/WT	PANEL LAMP DIMMER SWITCH SIGNAL
9	A6 14RD/LB	FUSED B(+)
10	-	-
11	F34 16TN/BK	LOW HEADLAMP SWITCH SENSE
12	-	-
13	L24 20LB/RD	AUTO HEADLAMP SWITCH SENSE
14	-	-
15	366 16PK/OR	PARK LAMP FEED
16	L90 20DB/RD	PARK LAMP RELAY OUTPUT



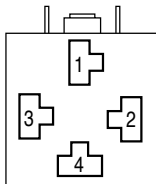
HIGH PRESSURE CUT-OUT SWITCH (MAX COOLING)

CAV	CIRCUIT	FUNCTION
1	C29 16TN	IGNITION RELAY CONTROL
1	C4 16TN/BK*	
2	Z1 16BK	GROUND



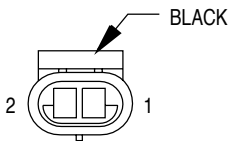
HIGH SPEED BLOWER MOTOR RELAY

CAV	CIRCUIT	FUNCTION
1	A19 14RD/VT	FUSED B(+)
2	C42 12BR/RD	BLOWER MOTOR DRIVER
3	-	-
4	C41 20BR	HIGH BLOWER MOTOR RELAY CONTROL
5	A19 12DG/RD	FUSED B(+)
6	-	-



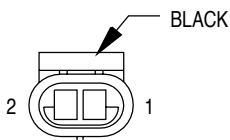
HIGH SPEED COOLING FAN RELAY (MAX COOLING)

CAV	CIRCUIT	FUNCTION
1	C25 10RD/WT	RADIATOR FAN RELAY OUTPUT
2	Z1 16BK	GROUND
3	C111 16DG/YL	BLOWER RELAY FEED
4	F143 10LG/RD	FUSED B(+)
4	F141 10LG/RD*	FUSED B(+)



HORN NO. 1

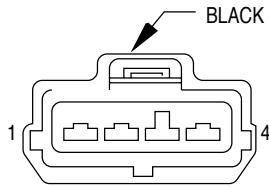
CAV	CIRCUIT	FUNCTION
1	X2 16DG/YL	HORN RELAY OUTPUT
2	Z1 16BK	GROUND



HORN NO. 2

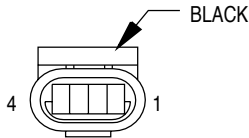
CAV	CIRCUIT	FUNCTION
1	X2 16DG/YL	HORN RELAY OUTPUT
2	Z1 16BK	GROUND

* 4.0L



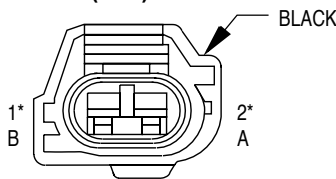
IDLE AIR CONTROL MOTOR (4.0L)

CAV	CIRCUIT	FUNCTION
1	K60 16YL/BK	IDLE AIR CONTROL NO. 2 DRIVER
2	K59 16VT/BK	IDLE AIR CONTROL NO. 4 DRIVER
3	K40 16BR/WT	IDLE AIR CONTROL NO. 3 DRIVER
4	K39 16GY/RD	IDLE AIR CONTROL NO. 1 DRIVER



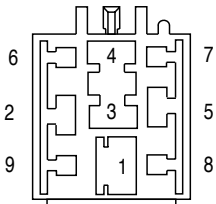
IDLE AIR CONTROL MOTOR (5.2L)

CAV	CIRCUIT	FUNCTION
1	K39 16GY/RD	IDLE AIR CONTROL NO. 1 DRIVER
2	K40 16BR/WT	IDLE AIR CONTROL NO. 3 DRIVER
3	K59 16VT/BK	IDLE AIR CONTROL NO. 4 DRIVER
4	K60 16YL/BK	IDLE AIR CONTROL NO. 2 DRIVER



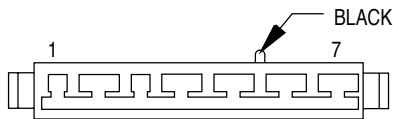
IGNITION COIL

CAV	CIRCUIT	FUNCTION
A	K19 18GY/WT	IGNITION COIL NO. 1 DRIVER
B	A142 18DG/OR	AUTOMATIC SHUTDOWN RELAY OUTPUT
1*	A142 18DG/OR	AUTOMATIC SHUTDOWN RELAY OUTPUT
2*	K19 18GY/WT	IGNITION COIL NO. 1 DRIVER



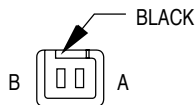
IGNITION RELAY (MAX COOLING)

CAV	CIRCUIT	FUNCTION
1	F99 16OR	FUSED IGNITION (ST-RUN)
2	F99 16OR	FUSED IGNITION (ST-RUN)
3	C116 16LG/WT	LOW SPEED RELAY FEED
4	C111 16DG/YL	RELAY OUTPUT
5	C29 16TN	RELAY CONTROL
6	-	-
7	-	-
8	-	-
9	-	-



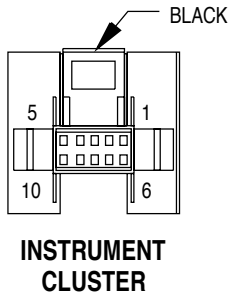
IGNITION SWITCH

CAV	CIRCUIT	FUNCTION
1	A41 14YL	IGNITION SWITCH OUTPUT (ST)
2	A21 12DB/GY	IGNITION SWITCH OUTPUT (ST-RUN)
3	G9 18GY/BK	RED BRAKE WARNING LAMP DRIVER
4	A1 12RD/WT	FUSED B(+)
5	A22 12BK/OR	IGNITION SWITCH OUTPUT (RUN)
6	A31 12RD/BK	IGNITION SWITCH OUTPUT (RUN-ACC)
7	A1 12RD/WT	FUSED B(+)

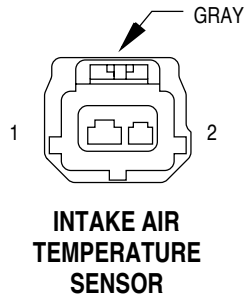


IN-CAR TEMPERATURE SENSOR

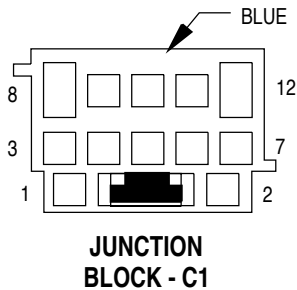
CAV	CIRCUIT	FUNCTION
A	C10 20RD/TN	IN-CAR TEMPERATURE SENSOR SIGNAL
B	D41 20LG/WT	SENSOR GROUND



CAV	CIRCUIT	FUNCTION
1	Z1 20BK	GROUND
2	Z2 20BK/OR	GROUND
3	F75 18VT	FUSED B(+)
4	205 20WT/VT	ABS WARNING LAMP DRIVER
5	F87 20BK/WT	FUSED IGNITION SWITCH OUTPUT (ST-RUN)
6	L65 18LG/DB	LEFT TURN SIGNAL
7	L64 18TN/DB	RIGHT TURN SIGNAL
8	D1 18VT/BR	CCD BUS (+)
9	D2 18WT/BK	CCD BUS (-)
10	E2 20OR	PANEL LAMP DRIVER

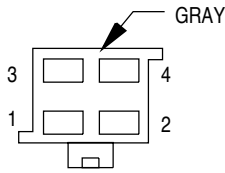


CAV	CIRCUIT	FUNCTION
1	K21 16BK/RD	INTAKE AIR TEMPERATURE SENSOR SIGNAL
2	K4 16BK/LB	SENSOR GROUND



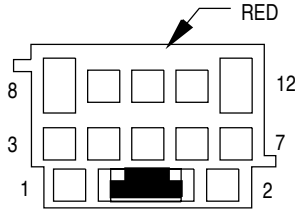
CAV	CIRCUIT	FUNCTION
1	M1 18PK	FUSED B(+)
2	L10 18BR/LG	BACK-UP LAMP SWITCH OUTPUT
3	-	-
4	-	-
5	-	-
6	-	-
7	T107 20BK/RD	4-WHEEL DRIVE PART TIME LAMP
8	-	-
9	L90 18DB/RD	PARK LAMP RELAY OUTPUT
10	-	-
11	F12 18DB/WT*	FUSED IGNITION SWITCH OUTPUT (RUN)
11	F12 20DB/WT**	FUSED IGNITION SWITCH OUTPUT (RUN)
12	-	-

* GAS
** DIESEL



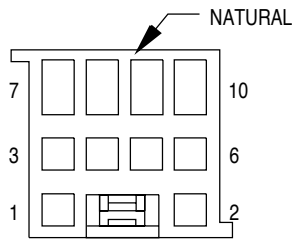
**JUNCTION
BLOCK - C2**

CAV	CIRCUIT	FUNCTION
1	A21 12DB/GY	IGNITION SWITCH OUTPUT (ST-RUN)
2	A7 12YL/RD	FUSED B(+)
3	A900 12OR/YL	FUSED B(+)
4	A250 10RD	FUSED B(+)



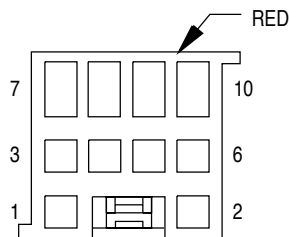
**JUNCTION
BLOCK - C3**

CAV	CIRCUIT	FUNCTION
1	X4 20GY/OR	HORN RELAY CONTROL
2	-	-
3	G28 20LG/OR	2-WHEEL DRIVE LAMP/LOW RANGE
4	L39 18LB	FOG LAMP RELAY OUTPUT
5	F62 18RD	FUSED B(+)
6	-	-
7	-	-
8	A6 14RD/LB	FUSED B(+)
9	-	-
10	-	-
11	L64 18TN/DB	TURN SIGNAL SWITCH OUTPUT
12	F86 16LG/RD	FUSED IGNITION SWITCH OUTPUT (RUN-ACC)



**JUNCTION
BLOCK - C4**

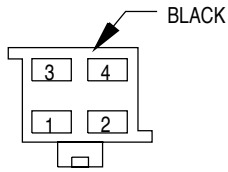
CAV	CIRCUIT	FUNCTION
1	L64 18TN/DB	RIGHT TURN SIGNAL INDICATOR LAMP
2	107 20BK/RD	4-WHEEL DRIVE PART TIME LAMP
3	F30 18RD/DB	FUSED IGNITION SWITCH OUTPUT (RUN-ACC)
4	A31 18RD/BK	FUSED IGNITION SWITCH OUTPUT (RUN-ACC)
5	L64 18TN/DB	RIGHT TURN SIGNAL INDICATOR LAMP
6	107 20BK/RD**	4-WHEEL DRIVE PART TIME LAMP
7	F86 16LG/BK*	FUSED IGNITION SWITCH OUTPUT (RUN-ACC)
	F86 16LG/BK	FUSED IGNITION SWITCH OUTPUT (RUN-ACC)
8	F75 18VT	FUSED B(+)
9	F75 18VT	FUSED B(+)
10	L11 16LG/BK**	FLASH TO PASS



**JUNCTION
BLOCK - C5**

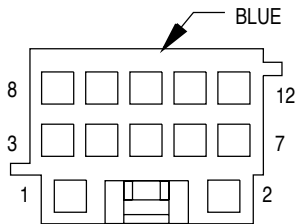
CAV	CIRCUIT	FUNCTION
1	L5 18OR/BK	TURN SIGNAL
2	G28 20LG/OR	2-WHEEL DRIVE OR REAR WHEEL IN ALL TIME
3	-	-
4	Z1 18BK	GROUND
5	X60 20DG/RD	RADIO 12 VOLT OUTPUT
6	G28 20LG/OR	ALL TIME FRONT WHEELS
7	-	-
8	F34 16TN/BK	AUTOMATIC HEADLAMP RELAY OUTPUT
9	A6 14RD/LB	FUSED B(+)
10	A22 12BK/OR	FUSED IGNITION SWITCH OUTPUT (RUN)

* POWER SUNROOF
** LHD



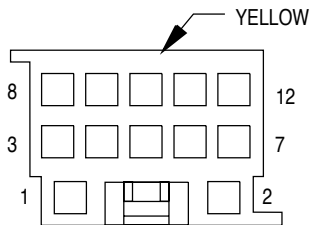
**JUNCTION
BLOCK - C6**

CAV	CIRCUIT	FUNCTION
1	A31 12RD/BK	FUSED IGNITION SWITCH OUTPUT (RUN-ACC)
2	A21 12DB/GY	FUSED IGNITION SWITCH OUTPUT (ST-RUN)
3	C15 12BK/WT	REAR WINDOW DEFOGGER RELAY OUTPUT
4	F61 16WT/OR	FUSED B(+)



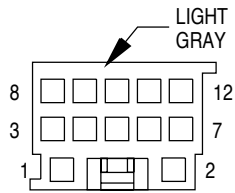
**JUNCTION
BLOCK - C7**

CAV	CIRCUIT	FUNCTION
1	X12 18RD/GY	FUSED IGNITION SWITCH OUTPUT (RUN-ACC)
2	-	-
3	L95 18DG/YL	FUSED B(+)
4	A31 18RD/BK	FUSED IGNITION SWITCH OUTPUT (RUN-ACC)
5	L12 18VT/TN	HAZARD SIGNAL
6	L36 18LG	REAR FOG LAMP
7	L96 20LG/RD	REAR FOG LAMP RELAY CONTROL
8	L39 20LB	FOG LAMP RELAY OUTPUT
9	Z1 18BK	GROUND
10	L95 18DG/YL	FUSED B(+)
11	-	-
12	X4 20GY/OR	HORN RELAY CONTROL



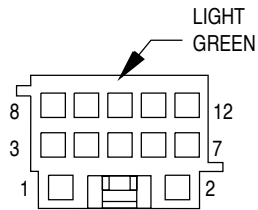
**JUNCTION
BLOCK - C8**

CAV	CIRCUIT	FUNCTION
1	F83 18YL/DG	FUSED IGNITION SWITCH OUTPUT (RUN)
2	M2 20YL	COURTESY LAMP RELAY OUTPUT
3	M1 20PK	FUSED B(+)
4	L90 20DB/RD	PARK LAMP RELAY OUTPUT
5	L90 20DB/RD	PARK LAMP RELAY OUTPUT
6	M1 20PK	FUSED B(+)
7	M2 20YL	COURTESY LAMP RELAY OUTPUT
8	M1 20PK	FUSED B(+)
9	-	-
10	L90 20DB/RD	PARK LAMP SWITCH OUTPUT
11	M1 20PK	FUSED B(+)
12	M2 20YL	COURTESY LAMP RELAY OUTPUT



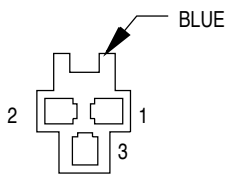
JUNCTION BLOCK - C9

CAV	CIRCUIT	FUNCTION
1	C16 20LB/YL	REAR WINDOW DEFOGGER LAMP DRIVER
2	F38 18OR	FUSED B(+)
3	-	-
4	F71 20DG/PK	FUSED IGNITION SWITCH OUTPUT (RUN)
5	F60 20RD/WT	FUSED B(+)
6	-	-
7	-	-
8	F87 20BK/WT	FUSED IGNITION SWITCH OUTPUT (ST-RUN)
9	F71 20PK/DG	FUSED IGNITION SWITCH OUTPUT (RUN)
10	F60 20RD/WT	FUSED B(+)
11	366 16PK/OR	PARK LAMP FEED
12	F60 20WT/RD*	FUSED B(+)



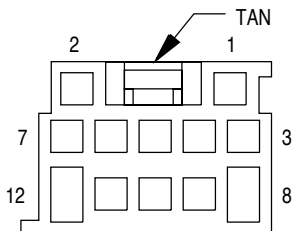
JUNCTION BLOCK - C10

CAV	CIRCUIT	FUNCTION
1	L95 20DG/YL	FOG LAMP RELAY CONTROL
2	V23 18BR/PK	FUSED IGNITION SWITCH OUTPUT (RUN-ACC)
3	L16 18RD/LG	FUSED B(+)
4	-	-
5	V23 20BR/PK	FUSED IGNITION SWITCH OUTPUT (RUN-ACC)
6	M112 20BR/LG	COURTESY LAMP RELAY CONTROL
7	X4 20GY/OR	HORN RELAY CONTROL
8	C14 20WT/RD	REAR WINDOW DEFOGGER RELAY CONTROL
9	-	-
10	L79 20TN	PARK LAMP RELAY CONTROL
11	L90 20DB/RD	PARK LAMP RELAY OUTPUT
12	714 20BK/OR	AUTOMATIC HEADLAMP RELAY CONTROL



JUNCTION BLOCK - C11

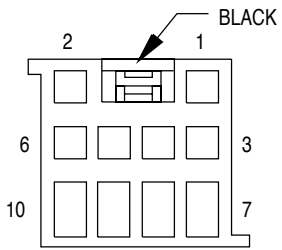
CAV	CIRCUIT	FUNCTION
1	X17 20DG	POWER ANTENNA UP CONTROL
2	X14 20WT	POWER ANTENNA DOWN CONTROL
3	X16 20GY	POWER ANTENNA DRIVER



JUNCTION BLOCK - C13

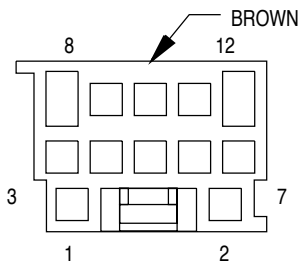
CAV	CIRCUIT	FUNCTION
1	F20 18WT	FUSED IGNITION SWITCH OUTPUT (RUN)
2	-	-
3	-	-
4	L90 18DB/RD	PARK LAMP RELAY OUTPUT
5	M1 20PK	FUSED B(+)
6	-	-
7	F87 18WT/PK	FUSED IGNITION SWITCH OUTPUT (ST-RUN)
8	F75 14VT	FUSED B(+)
9	-	-
10	-	-
11	-	-
12	F35 16RD	FUSED B(+)

* ATC



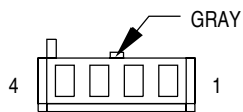
**JUNCTION
BLOCK - C14**

CAV	CIRCUIT	FUNCTION
1	L10 18BR/LG	BACK-UP LAMP SWITCH OUTPUT
2	G5 18DB/WT	FUSED IGNITION SWITCH OUTPUT (ST-RUN)
3	M2 20YL	COURTESY LAMP RELAY OUTPUT
4	X60 18DG/RD	RADIO 12-VOLT OUTPUT
5	-	-
6	-	-
7	F81 12TN	FUSED B(+)
8	F70 14PK/BK	FUSED B(+)
9	F81 12TN	FUSED B(+)
10	F35 16RD	FUSED B(+)



**JUNCTION
BLOCK - C15**

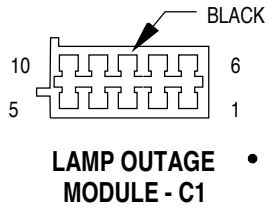
CAV	CIRCUIT	FUNCTION
1	-	-
2	Z1 16BK	GROUND
3	F83 20YL/DG*	FUSED IGNITION SWITCH OUTPUT (RUN)
3	F83 20BK/VT	FUSED IGNITION SWITCH OUTPUT (RUN)
4	-	-
5	-	-
6	-	-
7	L10 20BK/RD	BACK-UP LAMP SWITCH OUTPUT
8	-	-
9	M1 20PK	FUSED B(+)
10	-	-
11	M2 20YL	COURTESY LAMP RELAY OUTPUT
12	-	-



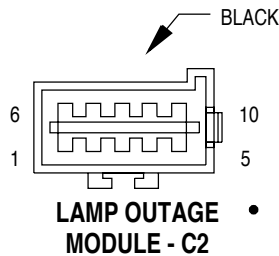
**KEY-IN SWITCH/
HALO LAMP**

CAV	CIRCUIT	FUNCTION
1	Z1 20BK	GROUND
2	G26 20LB	KEY-IN IGNITION SWITCH SENSE
3	M2 20YL	COURTESY LAMP RELAY OUTPUT
4	M1 20PK	FUSED B(+)

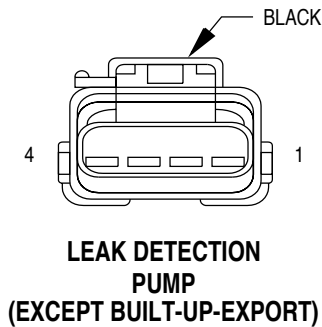
* OVERHEAD CONSOLE



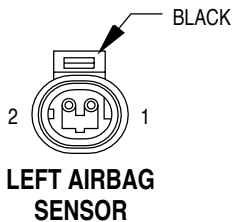
CAV	CIRCUIT	FUNCTION
1	L36 18LG/OR	REAR FOG LAMP
2	L50 18WT/TN	STOP LAMP SWITCH OUTPUT
3	L90 18DB/RD	PARK LAMP RELAY OUTPUT
	L90 18DB/RD	PARK LAMP RELAY OUTPUT
4	L90 18DB/RD	PARK LAMP RELAY OUTPUT
	L90 18DB/RD	PARK LAMP RELAY OUTPUT
5	L90 18DB/RD	PARK LAMP RELAY OUTPUT
6	L50 18WT/TN	STOP LAMP SWITCH OUTPUT
7	L50 18WT/TN	STOP LAMP SWITCH OUTPUT
8	L50 18WT/TN	STOP LAMP SWITCH OUTPUT
9	G46 20LB/BK	REAR LAMP OUT INDICATOR DRIVER
10	F87 18WT/PK	FUSED IGNITION SWITCH OUTPUT (ST-RUN)



CAV	CIRCUIT	FUNCTION
1	L36 18LG/OR	REAR FOG LAMP
	L36 18LG/OR	REAR FOG LAMP
2	L50 18WT/TN	BRAKE LAMP SWITCH OUTPUT
3	L90 18DB/RD*	PARK LAMP RELAY OUTPUT
	L90 18DB/RD	PARK LAMP RELAY OUTPUT
4	L22 18LB	PARK LAMP SWITCH OUTPUT
5	L21 18LB/WT	PARK LAMP SWITCH OUTPUT
6	L74 18PK/BK	STOP LAMP SWITCH OUTPUT
7	L73 18PK/WT	STOP LAMP SWITCH OUTPUT
8	L87 18DG/WT	BRAKE LAMP SWITCH OUTPUT
9	Z1 18BK	GROUND
10	-	-



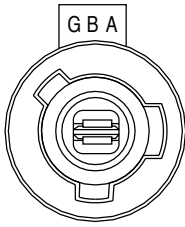
CAV	CIRCUIT	FUNCTION
1	-	-
2	F99 20OR	FUSED IGNITION SWITCH OUTPUT (ST-RUN)
3	J95 18DG/RD	VAPOR CANISTER SOLENOID DRIVER
4	J96 18VT/RD	VAPOR CANISTER PUMP SWITCH DRIVER



CAV	CIRCUIT	FUNCTION
1	R47 18DB/LB	LEFT IMPACT SENSOR LINE 1
2	R49 18LB	LEFT IMPACT SENSOR LINE 2

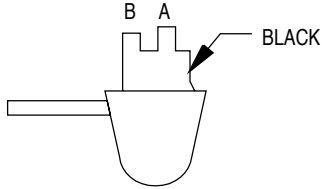
• WITHOUT LAMP OUTAGE MODULE, C1 AND C2 MATE TO MAKE C316

* TRAILER TOW



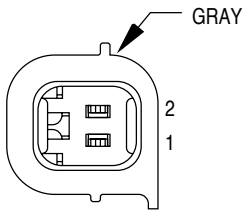
LEFT BACK-UP LAMP

CAV	CIRCUIT	FUNCTION
A	L10 18BR/LG	BACK-UP LAMP SWITCH OUTPUT
G	Z1 18BK	GROUND



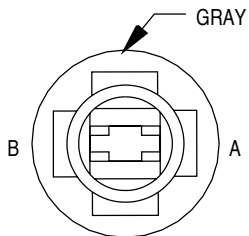
LEFT COURTESY LAMP

CAV	CIRCUIT	FUNCTION
A	M1 20PK	FUSED B(+)
B	M2 20YL	COURTESY LAMP RELAY OUTPUT



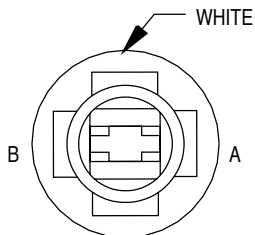
LEFT FOG LAMP

CAV	CIRCUIT	FUNCTION
1	Z1 18BK	GROUND
2	L39 18LB	FOG LAMP RELAY SWITCH OUTPUT



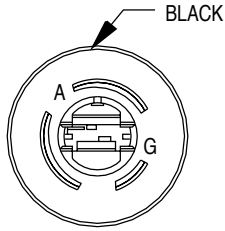
LEFT FRONT SIDE MARKER LAMP

CAV	CIRCUIT	FUNCTION
A	L90 18DB/RD	PARK LAMP RELAY OUTPUT
B	Z1 18BK	GROUND



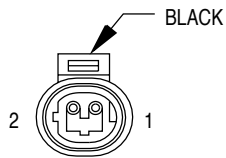
LEFT FRONT PARK LAMP

CAV	CIRCUIT	FUNCTION
A	L90 18DB/RD	PARK LAMP RELAY OUTPUT
B	Z1 18BK	GROUND



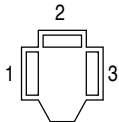
**LEFT FRONT
TURN SIGNAL
LAMP**

CAV	CIRCUIT	FUNCTION
A	L65 18LG/DB	TURN SIGNAL SWITCH OUTPUT
G	Z1 18BK	GROUND



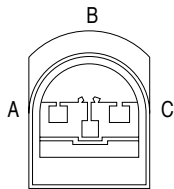
**LEFT FRONT
WHEEL SPEED
SENSOR**

CAV	CIRCUIT	FUNCTION
1	B8 18RD/DB	LEFT FRONT WHEEL SPEED SENSOR (-)
2	B9 18RD	LEFT FRONT WHEEL SPEED SENSOR (+)



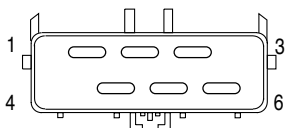
**LEFT HEADLAMP
(BUILT-UP-EXPORT)**

CAV	CIRCUIT	FUNCTION
1	L3 16RD/OR	DIMMER SWITCH HIGH BEAM OUTPUT
2	L4 16VT/OR	DIMMER SWITCH LOW BEAM OUTPUT
3	Z1 16BK	GROUND



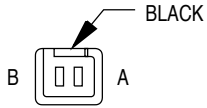
**LEFT HEADLAMP
(EXCEPT BUILT-
UP-EXPORT)**

CAV	CIRCUIT	FUNCTION
A	Z1 16BK	GROUND
B	L4 16VT/OR	DIMMER SWITCH LOW BEAM OUTPUT
C	L3 16RD/OR	DIMMER SWITCH HIGH BEAM OUTPUT



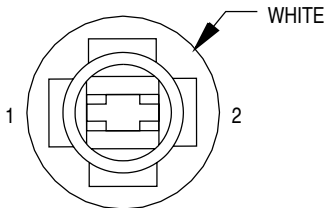
**LEFT HEADLAMP
LEVELING MOTOR**

CAV	CIRCUIT	FUNCTION
1	L104 20LG	HEADLAMP LEVELING POSITION 4
2	L103 20LB	HEADLAMP LEVELING POSITION 3
3	L102 20WT	HEADLAMP LEVELING POSITION 2
4	L105 20PK	HEADLAMP LEVELING POSITION 5
5	L106 20YL	HEADLAMP LEVELING POSITION 6
6	L101 20RD	HEADLAMP LEVELING POSITION 1



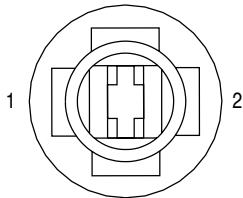
**LEFT INSTRUMENT
PANEL SPEAKER**

CAV	CIRCUIT	FUNCTION
A	X87 20LG/RD	AMPLIFIED LEFT FRONT (+)
B	X85 20LG/BK	AMPLIFIED LEFT FRONT (-)



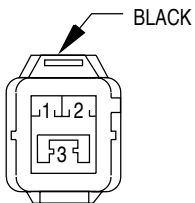
**LEFT LICENSE
LAMP**

CAV	CIRCUIT	FUNCTION
1	L90 20DB/RD	PARK LAMP RELAY OUTPUT
2	Z1 20BK	GROUND



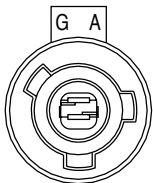
**LEFT PARK
LAMP**

CAV	CIRCUIT	FUNCTION
1	L90 18DB/RD	PARK LAMP RELAY
2	Z1 18BK	GROUND



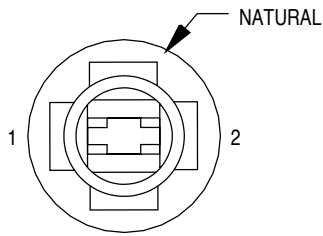
**LEFT PARK/
TURN SIGNAL
MARKER**

CAV	CIRCUIT	FUNCTION
1	L65 18LG/DB	LEFT FRONT TURN SIGNAL FEED
2	L90 18DB/RD	PARK LAMP SWITCH OUTPUT
3	Z1 18BK	GROUND



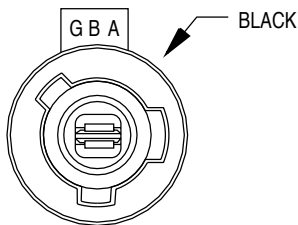
**LEFT REAR
FOG LAMP
(BUILT-UP-EXPORT)**

CAV	CIRCUIT	FUNCTION
A	L36 18LG/BK	REAR FOG LAMP
G	Z1 18BK	GROUND



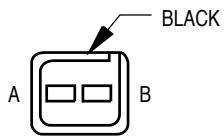
**LEFT REAR
SIDE MARKER
LAMP
(EXCEPT BUILT-UP-EXPORT)**

CAV	CIRCUIT	FUNCTION
1	Z1 18BK	GROUND
2	L21 18LB/WT	PARK LAMP SWITCH OUTPUT



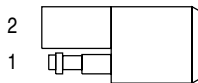
**LEFT REAR
TURN SIGNAL
LAMP**

CAV	CIRCUIT	FUNCTION
A	L60 18TN	TURN SIGNAL SWITCH OUTPUT
G	Z1 18BK	GROUND



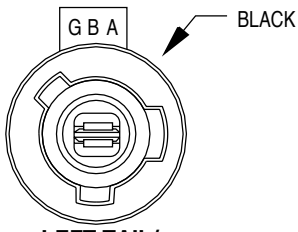
**LEFT REAR
WHEEL SPEED
SENSOR**

CAV	CIRCUIT	FUNCTION
A	B3 20LG/DB	LEFT REAR WHEEL SPEED SENSOR (-)
B	B4 20LG	LEFT REAR WHEEL SPEED SENSOR (+)



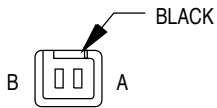
**LEFT SIDE
REPEATER**

CAV	CIRCUIT	FUNCTION
1	Z1 18BK	GROUND
2	L65 18LG/DB	LEFT FRONT TURN SIGNAL FEED



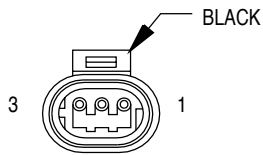
**LEFT TAIL/
STOP LAMP**

CAV	CIRCUIT	FUNCTION
A	L73 18PK/WT	STOP LAMP SWITCH OUTPUT
B	L21 18LB/WT	PARK LAMP SWITCH OUTPUT
G	Z1 18BK	GROUND



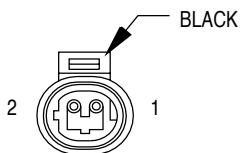
**LEFT VISOR/
VANITY LAMP**

CAV	CIRCUIT	FUNCTION
A	M1 20PK	FUSED B(+)
B	Z1 20BK	GROUND



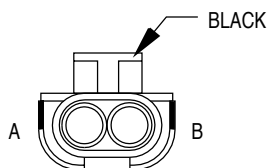
**LIFTGATE
AJAR SWITCH**

CAV	CIRCUIT	FUNCTION
1	Z1 16BK	GROUND
2	G78 16TN/BK	LIFTGATE AJAR SWITCH SENSE
3	-	-



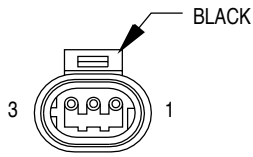
**LIFTGATE
CYLINDER LOCK
SWITCH**

CAV	CIRCUIT	FUNCTION
1	G71 20VT/YL	VTSS DISARM SENSE
2	Z1 20BK	GROUND



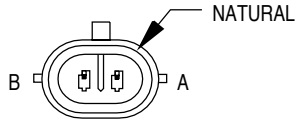
**LIFTGATE
LOCK MOTOR**

CAV	CIRCUIT	FUNCTION
A	P2 16BK/WT	DOOR LOCK DRIVER
B	P34 16PK/BK	DOOR UNLOCK DRIVER



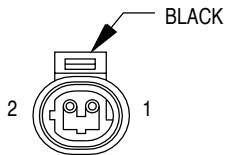
**LIFTGLASS
AJAR SWITCH**

CAV	CIRCUIT	FUNCTION
1	Z1 16BK	GROUND
2	G78 16TN/BK	LIFTGLASS AJAR SWITCH SENSE
3	-	-



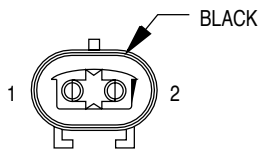
**LIFTGLASS
LIMIT SWITCH**

CAV	CIRCUIT	FUNCTION
A	F70 16PK/BK	FUSED B(+)
B	P101 16OR/PK	LIFTGLASS LIMIT SWITCH OUTPUT



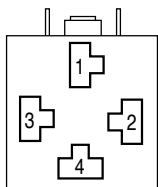
**LIFTGLASS
PUSH BUTTON**

CAV	CIRCUIT	FUNCTION
1	P100 14OR/BR	LIFTGLASS PUSH BUTTON OUTPUT
2	P101 16OR/PK	LIFTGLASS LIMIT SWITCH OUTPUT



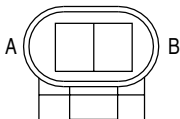
**LIFTGLASS
RELEASE
SOLENOID**

CAV	CIRCUIT	FUNCTION
1	P100 14OR/BR	LIFTGLASS PUSH BUTTON OUTPUT
2	Z1 14BK	GROUND



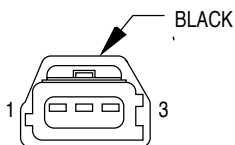
**LOW SPEED COOLING
FAN RELAY
(MAX COOLING)**

CAV	CIRCUIT	FUNCTION
1	C23 10DG	RELAY OUTPUT
2	C4 16TN/BK	RELAY CONTROL
3	C116 16LG/WT	FUSED IGNITION (ST-RUN)
4	F143 10LG/RD	FUSED B(+)
4	F141 10LG/RD*	FUSED B(+)



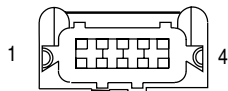
**LOWER HOSE
COOLANT SWITCH
(MAX COOLING)**

CAV	CIRCUIT	FUNCTION
A	C29 16TN	IGNITION RELAY CONTROL
B	Z1 16BK	GROUND



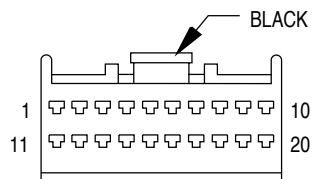
**MANIFOLD
ABSOLUTE
PRESSURE
SENSOR**

CAV	CIRCUIT	FUNCTION
1	K4 20BK/LB	SENSOR GROUND
2	K70 18RD/WT	MAP SENSOR SIGNAL
3	K25 20WT/BK	5-VOLT SUPPLY



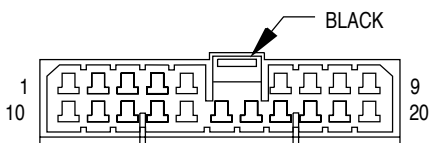
**MASS AIR
FLOW MODULE**

CAV	CIRCUIT	FUNCTION
1	Z1 20BK	GROUND
2	K4 20BK/LB	SENSOR GROUND
3	A142 18DG/OR	AUTOMATIC SHUT DOWN RELAY OUTPUT
4	K155 20DB	AIR FLOW METER SIGNAL



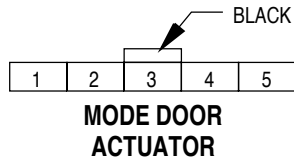
**MEMORY SEAT
MODULE - C1**

CAV	CIRCUIT	FUNCTION
1	P29 20BR/WT	6 VOLT SENSOR SUPPLY
2	P28 20BR/RD	SENSOR GROUND
3	P25 20VT/RD	HORIZONTAL POSITION SENSE
4	P26 20BR	FRONT RISER POSITION SENSE
5	P27 20LB/RD	REAR RISER POSITION SENSE
6	P47 20LB	RECLINER POSITION SENSE
7	P103 20DB/WT	LUMBAR POSITION SENSE
8	P21 18RD/LG	FRONT RISER DOWN SWITCH SENSE
9	P19 18YL/LG	FRONT RISER UP SWITCH SENSE
10	P13 18RD/WT	REAR RISER DOWN SWITCH SENSE
11	P11 18YL/WT	REAR RISER UP SWITCH SENSE
12	P15 18YL/LB	HORIZONTAL FORWARD SWITCH SENSE
13	P17 18RD/LB	HORIZONTAL REARWARD SWITCH SENSE
14	P40 18GY/LB	RECLINER UP SWITCH SENSE
15	P48 18GY/WT	RECLINER DOWN SWITCH SENSE
16	P105 20LG/DB	LUMBAR FORWARD SWITCH SENSE
17	P104 20YL/RD	LUMBAR REARWARD SWITCH SENSE
18	D1 20VT/BR	CCD BUS (+)
19	D2 20WT/BK	CCD BUS (-)
20	-	-

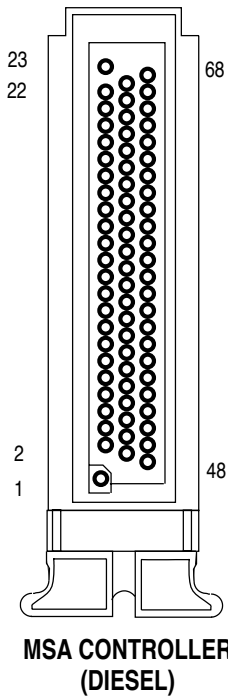


**MEMORY SEAT
MODULE - C2**

CAV	CIRCUIT	FUNCTION
1	Z1 16BK	GROUND
2	P115 16GY/LG	HORIZONTAL FORWARD DRIVER
3	P117 16RD/BR	HORIZONTAL REARWARD DRIVER
4	-	-
5	-	-
6	P43 16GY/LB	RECLINER REARWARD DRIVER
7	P41 16GY/WT	RECLINER FORWARD DRIVER
8	Z1 16BK	GROUND
9	P106 16DG/WT	LUMBAR REARWARD DRIVER
10	F35 16RD	FUSED B(+)
11	P113 16RD/BK	REAR RISER DOWN DRIVER
12	P111 16YL/DB	REAR RISER UP DRIVER
13	-	-
14	-	-
15	-	-
16	-	-
17	P121 16RD/GY	FRONT RISER DOWN DRIVER
18	P119 16YL/RD	FRONT RISER UP DRIVER
19	F35 16RD	FUSED B(+)
20	P107 16OR/BK	LUMBAR FORWARD DRIVER

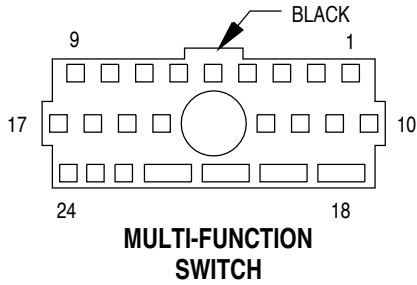


CAV	CIRCUIT	FUNCTION
1	C39 20YL	MODE DOOR MOTOR POSITION SENSE
2	C40 20DG/YL	5-VOLT SUPPLY
3	D41 20LG/WT	SENSOR RETURN
4	C38 20DG	MODE DOOR MOTOR DRIVER
5	C37 20TN/BK	MODE DOOR MOTOR DRIVER



CAV	CIRCUIT	FUNCTION
1	Z12 14BK/TN	POWER GROUND
2	G21 20GY/LB	TACHOMETER SIGNAL
3	K185 18OR/LB	WAIT TO START LAMP
4	K140 16TN/WT	FUEL QUANTITY ACTUATOR GROUND
5	K140 16TN/WT	FUEL QUANTITY ACTUATOR GROUND
7	K57 20LG/OR	CONT SLEEVE POSITION SENSE
8	K24 20GY/BK	CRANKSHAFT POSITION SENSOR
11	K68 18LG/YL	NEEDLE MOVE SENSOR (-)
12	K67 18BR/BK	NEEDLE MOVE SENSOR (+)
13	K155 20DB	AIR FLOW METER SIGNAL
14	K2 20TN/BK	ENGINE COOLANT TEMPERATURE SENSOR SIGNAL
15	K22 20OR/DB	THROTTLE POSITION SENSOR SIGNAL
20	V32 20YL/RD	SPEED CONTROL ON/OFF SWITCH SENSE
21	Z3 20BK/OR	GROUND
23	A142 14DG/OR	AUTOMATIC SHUT DOWN RELAY OUTPUT
24	Z12 16BK/TN	POWER GROUND
25	K35 16GY/YL	EGR SOLENOID CONTROL
26	K48 18OR/RD	FLT SIGNAL
27	K92 20PK	COIL DRIVER #2
28	C13 16DB/RD	A/C COMPRESSOR CLUTCH RELAY CONTROL
29	K134 20LB/BK	SLEEVE POSITION SENSOR (-)
33	K4 20BK/LB	SENSOR GROUND
36	K95 20PK/WT	VEHICLE SPEED CONTROL SWITCH SIGNAL
37	C103 20DG	A/C SWITCH SIGNAL
38	F99 20OR	FUSED IGNITION SWITCH OUTPUT (ST-RUN)
42	K900 20PK/BK	AUTOMATIC SHUT DOWN RELAY CONTROL
43	G7 20WT/OR	VEHICLE SPEED SENSOR SIGNAL
44	L50 18WT/TN	BRAKE LAMP SWITCH OUTPUT
45	A142 16DG/OR	AUTOMATIC SHUT DOWN RELAY OUTPUT
46	Z12 16BK/TN	POWER GROUND
49	K140 16TN/WT	FUEL QUANTITY ACTUATOR GROUND
50	K152 16WT	GLOW PLUG RELAY CONTROL SENSE
51	K238 16VT	FUEL TIMING SHUTOFF SOLENOID
52	K135 20WT/BK	SLEEVE POSITION SENSOR (+)
53	K153 20OR	SHUTOFF FEED
55	K255 20WT/DG	PEDAL POSITION SENSOR
57	K6 20VT/WT	5-VOLT SUPPLY
59	G69 20BK/OR	
61	D83 20BK/PK	SCI RECEIVE
63	K156 20GY	FUEL TEMPERATURE SENSOR SIGNAL
65	K151 20WT/RD	LOW IDLE POSITION SWITCH
68	A142 16DG/OR	AUTOMATIC SHUT DOWN RELAY OUTPUT

(CAVITIES NOT SHOWN ARE NOT USED)

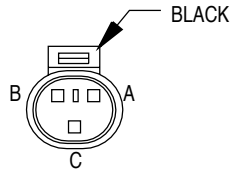


CAV	CIRCUIT	FUNCTION
1	V50 18LG/WT	WIPER SWITCH MODE SENSE
2	V51 18WT	WINDSHIELD WIPER SWITCH SIGNAL
3	V11 18TN/BK	WASHER SWITCH OUTPUT
	V11 18TN/BK	WASHER SWITCH OUTPUT
4	F86 16LG/BK	FUSED IGNITION SWITCH OUTPUT (RUN-ACC)
5	V4 18RD/YL	WIPER SWITCH HIGH SPEED OUTPUT
6	V3 18BR/WT	WIPER SWITCH LOW SPEED OUTPUT
	V3 18BR/WT	WIPER SWITCH LOW SPEED OUTPUT
7	V6 16DB	FUSED IGNITION SWITCH OUTPUT (RUN-ACC)
8	V6 16DB	FUSED IGNITION SWITCH OUTPUT (RUN-ACC)
9	V3 18BR/WT	WIPER SWITCH LOW SPEED OUTPUT
10	-	-
11	L64 18TN/DB	RIGHT TURN SIGNAL
12	L60 18TN	RIGHT TURN SIGNAL
13	L12 18VT/TN	HAZARD SIGNAL
14	-	-
15	L61 18DG	LEFT TURN SIGNAL
16	L65 18LG/DB	LEFT TURN SIGNAL
	L65 18LG/DB	LEFT TURN SIGNAL
17	L5 18OR/BK	TURN SIGNAL
	L5 18OR/BK	TURN SIGNAL
18	L4 16VT/OR	DIMMER SWITCH LOW BEAM OUTPUT
	L4 16VT/OR	DIMMER SWITCH LOW BEAM OUTPUT
19	F34 16TN/BK	LOW HEADLAMP SWITCH SENSE
	F34 16TN/BK	LOW HEADLAMP SWITCH SENSE
20	L3 16RD/OR	DIMMER SWITCH HIGH BEAM OUTPUT
21	L11 16LG/BK	FUSED B(+)
22	-	-
23	-	-
24	-	-



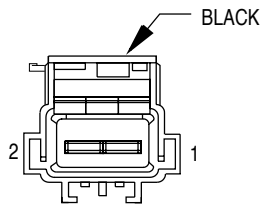
**NEEDLE SENSOR
(DIESEL)**

CAV	CIRCUIT	FUNCTION
1	K68 18LG/YL	NEEDLE MOVEMENT SENSOR (-)
2	K67 18BR/BK	NEEDLE MOVEMENT SENSOR (+)



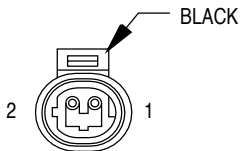
**OIL PRESSURE
SENSOR
(DIESEL)**

CAV	CIRCUIT	FUNCTION
A	K167 20BR/YL	SENSOR RETURN
B	K6 18VT/WT	5-VOLT SUPPLY
C	G60 20GY/YL	ENGINE OIL PRESSURE SENSOR SIGNAL



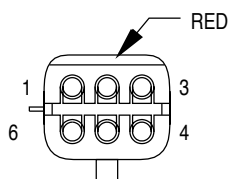
**OIL PRESSURE
SENSOR
(GAS)**

CAV	CIRCUIT	FUNCTION
1	G6 18GY/WT	OIL PRESSURE SENSOR SIGNAL
2	K4 20BK/LB	SENSOR GROUND



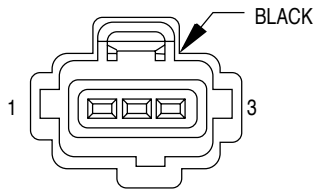
**OUTPUT SHAFT
SPEED SENSOR**

CAV	CIRCUIT	FUNCTION
1	T14 18LG/WT	OUTPUT SHAFT SPEED SENSOR SIGNAL (+)
2	T13 18DB/BK	OUTPUT SHAFT SPEED SENSOR SIGNAL (-)



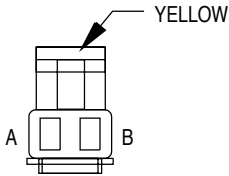
**OVERHEAD
CONSOLE**

CAV	CIRCUIT	FUNCTION
1	F83 20YL/DG	FUSED IGNITION SWITCH OUTPUT (RUN)
2	Z1 20BK	GROUND
3	D1 18VT/BR	CCD BUS(+)
4	M2 20YL	COURTESY LAMP RELAY OUTPUT
5	D2 18WT/BK	CCD BUS(-)
6	M1 20PK	FUSED B(+)



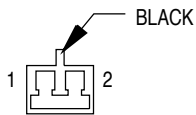
PARK/NEUTRAL POSITION SWITCH

CAV	CIRCUIT	FUNCTION
1	L10 18BR/LG	BACK-UP LAMP SWITCH OUTPUT
2	T41 20BK/WT	PARK/NEUTRAL POSITION SWITCH SENSE
3	F83 18YL/DG	FUSED IGNITION SWITCH OUTPUT (RUN)



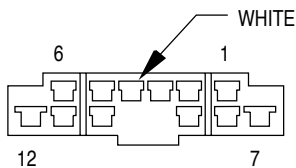
PASSENGER AIRBAG

CAV	CIRCUIT	FUNCTION
A	R44 18DB	PASSENGER AIRBAG LINE 2
B	R42 18VT	PASSENGER AIRBAG LINE 1



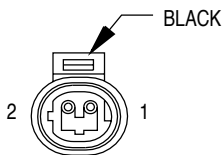
PASSENGER DOOR COURTESY LAMP

CAV	CIRCUIT	FUNCTION
1	M1 20PK	FUSED B(+)
2	Z1 20BK	GROUND



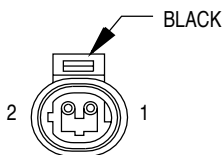
PASSENGER DOOR MODULE - C1

CAV	CIRCUIT	FUNCTION
1	Q12 16BR	RIGHT FRONT WINDOW DRIVER (UP)
2	Q22 16VT	RIGHT FRONT WINDOW DRIVER (DOWN)
3	Q18 16GY/BK	RIGHT REAR WINDOW DRIVER (UP)
4	Q28 16DG/WT	RIGHT REAR WINDOW DRIVER (DOWN)
5	P34 16PK/BK	RIGHT FRONT DOOR UNLOCK DRIVER
6	P2 16BK/WT	RIGHT FRONT DOOR LOCK DRIVER
7	Z1 12BK	GROUND
8	D1 18VT/BR	CCD BUS(+)
9	D2 18WT/BK	CCD BUS(-)
10	E20 18OR/DB	RIGHT REAR DOOR SWITCH ILLUMINATION
11	M1 20PK	MUX COURTESY LAMP DRIVER
12	F81 12TN	FUSED B(+)



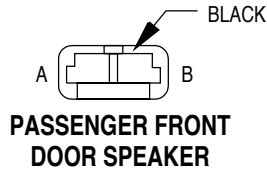
PASSENGER FRONT CYLINDER LOCK SWITCH

CAV	CIRCUIT	FUNCTION
1	G71 20VT/YL	VTSS DISARM SENSE
2	Z1 20BK	GROUND

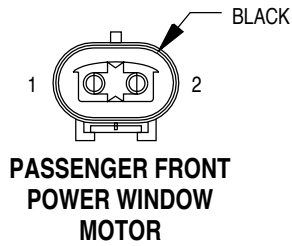


PASSENGER FRONT DOOR LOCK MOTOR

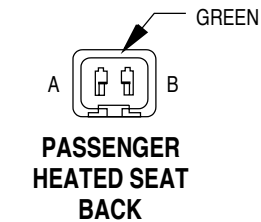
CAV	CIRCUIT	FUNCTION
1	P34 16PK/BK	DOOR UNLOCK DRIVER
2	P2 16BK/WT	DOOR LOCK DRIVER



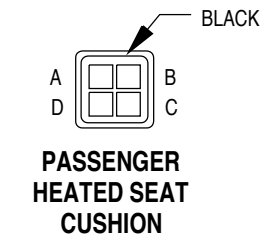
CAV	CIRCUIT	FUNCTION
A	X54 20VT	RIGHT FRONT (+)
B	X56 20DB/RD	RIGHT FRONT (-)



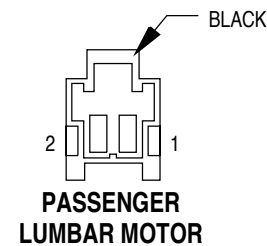
CAV	CIRCUIT	FUNCTION
1	Q12 16BR	RIGHT FRONT WINDOW DRIVER (UP)
2	Q22 16VT	RIGHT FRONT WINDOW DRIVER (DOWN)



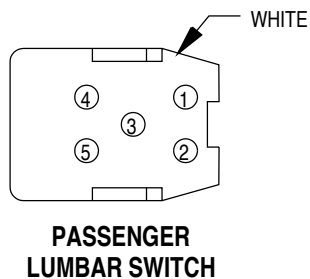
CAV	CIRCUIT	FUNCTION
A	Z1 16BK	GROUND
B	P88 16BR/BK	HEATED SEAT DRIVER



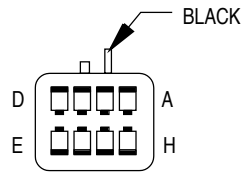
CAV	CIRCUIT	FUNCTION
A	P87 16BK/OR	HEATED SEAT DRIVER
B	P88 16BR/BK	HEATED SEAT DRIVER
C	P8 18LB/WT	PASSENGER HEATED SEAT SWITCH OUTPUT
D	Z1 20BK	GROUND



CAV	CIRCUIT	FUNCTION
1	P106 18DG/WT	LUMBAR FORWARD DRIVER
2	P107 18OR/BK	LUMBAR REARWARD DRIVER

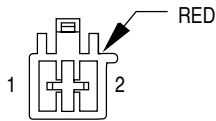


CAV	CIRCUIT	FUNCTION
1	P107 18OR/BK	LUMBAR REARWARD DRIVER
2	Z1 18BK	GROUND
3	F35 18RD	FUSED B(+)
4	Z1 18BK	GROUND
5	P106 18DG/WT	LUMBAR FORWARD DRIVER



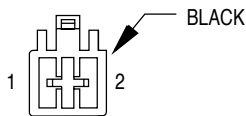
**PASSENGER
OUTSIDE POWER
MIRROR - C2**

CAV	CIRCUIT	FUNCTION
A	F75 20WT	HORIZONTAL DRIVER
B	Z1 20BK	HEATER SWITCHED GROUND
C	F84 20GN	VERTICAL POSITION SENSOR SIGNAL
D	F86 20GY	SENSOR GROUND
E	F85 20VT	HORIZONTAL POSITION SENSOR SIGNAL
F	C16 20BK	HEATER 12-VOLT SUPPLY
G	F73 20DB	COMMON DRIVER
H	F71 20YL	VERTICAL DRIVER



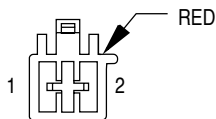
**PASSENGER
POWER SEAT
FRONT RISER
MOTOR**

CAV	CIRCUIT	FUNCTION
1	P20 16RD/LG	FRONT RISER DOWN SWITCH SENSE
2	P18 16YL/LG	FRONT RISER UP SWITCH SENSE



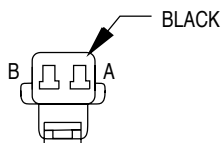
**PASSENGER
POWER SEAT
HORIZONTAL
MOTOR**

CAV	CIRCUIT	FUNCTION
1	P14 16YL/LB	HORIZONTAL FORWARD SWITCH SENSE
2	P16 16RD/LB	HORIZONTAL REARWARD SWITCH SENSE



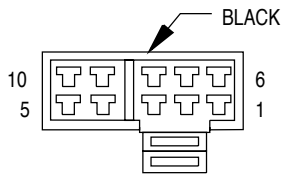
**PASSENGER
POWER SEAT
REAR RISER
MOTOR**

CAV	CIRCUIT	FUNCTION
1	P12 16RD/WT	REAR RISER DOWN SWITCH SENSE
2	P10 16YL/WT	REAR RISER UP SWITCH SENSE



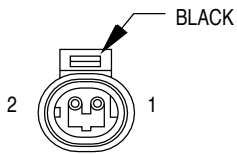
**PASSENGER
POWER SEAT
RECLINER
MOTOR**

CAV	CIRCUIT	FUNCTION
A	P42 16GY/WT	RECLINER DOWN DRIVER
B	P44 16GY/LB	RECLINER UP DRIVER



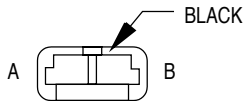
**PASSENGER
POWER SEAT
SWITCH**

CAV	CIRCUIT	FUNCTION
1	Z1 18BK	GROUND
2	P44 16GY/LB	RECLINER UP DRIVER
3	P16 16RD/LB	HORIZONTAL REARWARD SWITCH SENSE
4	P42 16GY/WT	RECLINER DOWN DRIVER
5	F35 16RD	FUSED B(+)
6	P14 16YL/LB	HORIZONTAL FORWARD SWITCH SENSE
7	P20 16RD/LG*	FRONT RISER DOWN SWITCH SENSE
7	P18 16YL/LG**	
8	P12 16RD/WT*	REAR RISER DOWN SWITCH SENSE
8	P10 16YL/WT**	
9	P10 16YL/WT*	REAR RISER UP SWITCH SENSE
9	P12 16RD/WT**	REAR RISER UP SWITCH SENSE
10	P18 16YL/LG*	FRONT RISER UP SWITCH SENSE
10	P20 16RD/LG**	FRONT RISER UP SWITCH SENSE



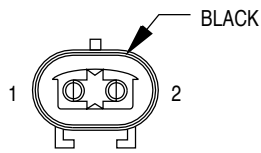
**PASSENGER REAR
DOOR LOCK
MOTOR**

CAV	CIRCUIT	FUNCTION
1	P34 18PK/BK	DOOR UNLOCK DRIVER
2	P2 18BK/WT	DOOR LOCK DRIVER



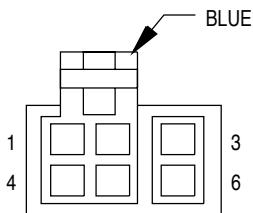
**PASSENGER REAR
DOOR SPEAKER**

CAV	CIRCUIT	FUNCTION
A	X52 20DB/WT	RIGHT REAR (+)
B	X58 20DB/OR	RIGHT REAR (-)



**PASSENGER REAR
POWER WINDOW
MOTOR**

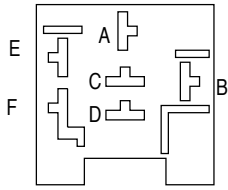
CAV	CIRCUIT	FUNCTION
1	Q12 16BR	RIGHT REAR WINDOW DRIVER (UP)
2	Q22 16VT	RIGHT REAR WINDOW DRIVER (DOWN)



**PASSENGER REAR
POWER WINDOW
SWITCH**

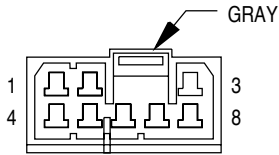
CAV	CIRCUIT	FUNCTION
1	Q18 14GY/BK	RIGHT REAR WINDOW DRIVER (UP)
2	Q12 16BR	RIGHT REAR WINDOW DRIVER (UP)
3	E20 20OR/DG	RIGHT REAR DOOR SWITCH ILLUMINATION
4	Q28 14DG/WT	RIGHT REAR WINDOW DRIVER (DOWN)
5	Q22 16VT	RIGHT REAR WINDOW DRIVER (DOWN)
6	Z1 16BK	GROUND

* LHD ** RHD



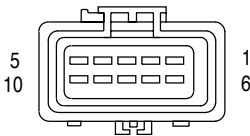
PASSENGER SEAT HEATER CONTROL MODULE (LHD)

CAV	CIRCUIT	FUNCTION
A	P87 16BK/OR	HEATED SEAT DRIVER
B	-	-
C	F87 18WT/BK	FUSED IGNITION SWITCH OUTPUT (RUN)
D	F35 16RD	FUSED B(+)
E	P8 18LB/WT	PASSENGER HEATED SEAT SWITCH OUTPUT
F	Z1 16BK	GROUND



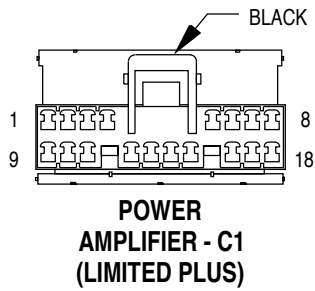
PASSENGER SEAT HEATER CONTROL MODULE (RHD)

CAV	CIRCUIT	FUNCTION
1	F87 18WT/BK	FUSED IGNITION SWITCH OUTPUT (RUN)
2	F35 16RD	FUSED B(+)
3	P87 16BK/OR	HEATED SEAT DRIVER
4	-	-
5	-	-
6	-	-
7	Z1 16BK	GROUND
8	P8 18LB/WT	PASSENGER HEATED SEAT SWITCH OUTPUT

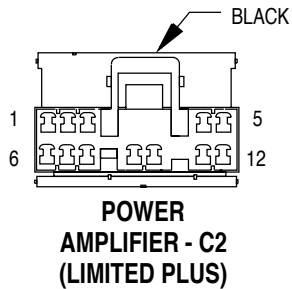


PEDAL POSITION SENSOR (DIESEL)

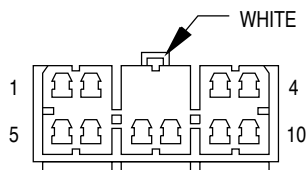
CAV	CIRCUIT	FUNCTION
1	-	-
2	-	-
3	K4 18BK/LB	SENSOR GROUND
4	-	-
5	K151 20WT	LOW IDLE POSITION SWITCH
6	-	-
7	K22 20OR/DB	THROTTLE POSITION SENSOR SIGNAL
8	K255 20WT/DG	PEDAL POSITION SENSOR
9	-	-
10	K6 20VT/WT	5-VOLT SUPPLY



CAV	CIRCUIT	FUNCTION
1	-	
2	F75 16VT	FUSED B(+)
3	Z5 16BK/LB	RADIO GROUND
4	-	-
5	X56 16DB	RIGHT FRONT SPEAKER (-)
6	X55 16BR/RD	LEFT FRONT SPEAKER (-)
7	X58 16DB/OR	RIGHT REAR SPEAKER (-)
8	X57 16BR/LB	LEFT REAR SPEAKER (-)
9	-	-
10	F75 16VT	FUSED B(+)
11	Z5 16BK/LB	RADIO GROUND
12	-	-
13	X60 18DG/RD	RADIO 12-VOLT OUTPUT
14	-	-
15	X54 16VT	RIGHT FRONT SPEAKER (+)
16	X53 16DG	LEFT FRONT SPEAKER (+)
17	X52 16DB/WT	RIGHT REAR SPEAKER (+)
18	X51 16BR/YL	LEFT REAR SPEAKER (+)

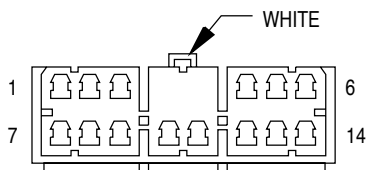


CAV	CIRCUIT	FUNCTION
1	X82 16LB/RD	AMPLIFIED FRONT SPEAKER (+)
2	X80 16LB/DG	AMPLIFIED FRONT SPEAKER (-)
3	X91 16WT/BK	AMPLIFIED REAR SPEAKER (-)
4	X95 16BR/YL	AMPLIFIED REAR SPEAKER (+)
5	X96 16DB/OR	AMPLIFIED RIGHT REAR SPEAKER (-)
6	X87 16LG/RD	AMPLIFIED FRONT SPEAKER (+)
7	X85 16LG/BK	AMPLIFIED FRONT SPEAKER (-)
8	X93 16WT/RD	AMPLIFIED REAR SPEAKER (+)
9	X92 16TN/BK	AMPLIFIED REAR SPEAKER (+)
10	X94 16TN/RD	AMPLIFIED REAR SPEAKER (-)
11	X97 16BR/LB	AMPLIFIED REAR SPEAKER (-)
12	X98 16DB/WT	AMPLIFIED REAR SPEAKER (+)



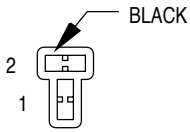
**POWER
AMPLIFIER - C1
(PREMIUM)**

CAV	CIRCUIT	FUNCTION
1	X82 16LB/RD	AMPLIFIED FRONT SPEAKER (+)
2	X80 16LB/DG	AMPLIFIED FRONT SPEAKER (-)
3	X94 16TN/RD	AMPLIFIED REAR DOOR SPEAKER (+)
4	X54 16VT	RIGHT FRONT SPEAKER (+)
5	X58 16DB/OR	RIGHT REAR SPEAKER (-)
6	X52 16DB/WT	RIGHT REAR SPEAKER (+)
7	-	-
8	X60 18DG/RD	RADIO 12-VOLT OUTPUT
9	X92 16TN/BK	AMPLIFIED REAR DOOR SPEAKER (-)
10	X56 16DB	RIGHT FRONT SPEAKER (-)



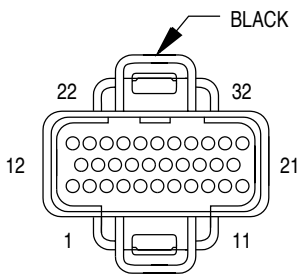
**POWER
AMPLIFIER - C2
(PREMIUM)**

CAV	CIRCUIT	FUNCTION
1	X93 16WT/RD	AMPLIFIED REAR DOOR SPEAKER (+)
2	F75 16VT	FUSED B(+)
3	X87 16LG/RD	AMPLIFIED FRONT SPEAKER (+)
4	-	-
5	X51 16BR/YL	LEFT REAR SPEAKER (+)
6	X53 16DG	LEFT FRONT SPEAKER (+)
7	X91 16WT/BK	AMPLIFIED REAR DOOR SPEAKER (-)
8	F75 16VT	FUSED B(+)
9	X85 16LG/BK	AMPLIFIED FRONT SPEAKER (-)
10	Z5 16BK/LB	GROUND
11	Z5 16BK/LB	GROUND
12	-	-
13	X57 16BR/LB	LEFT REAR SPEAKER (-)
14	X55 16BR/RD	LEFT FRONT SPEAKER (-)



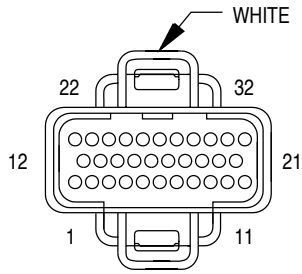
**POWER OUTLET
(RHD)**

CAV	CIRCUIT	FUNCTION
1	F38 18OR	FUSED B(+)
2	Z1 18BK	GROUND



**POWERTRAIN
CONTROL
MODULE - C1**

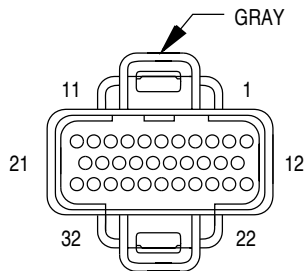
CAV	CIRCUIT	FUNCTION
1	-	-
2	F99 18OR	FUSED IGNITION SWITCH OUTPUT (ST-RUN)
3	-	-
4	K4 18BK/LB	SENSOR GROUND
5	-	-
6	T41 18BK/WT	PARK/NEUTRAL POSITION SWITCH SENSE
7	K19 18GY/WT	IGNITION COIL NO. 1 DRIVER
8	K27 18RD/LG	CRANKSHAFT POSITION SENSOR SIGNAL
9	-	-
10	K59 16VT/BK	IDLE AIR CONTROL NO. 4 DRIVER
11	K40 16BR/WT	IDLE AIR CONTROL NO. 3 DRIVER
12	-	-
13	-	-
14	-	-
15	K21 16BK/RD	INTAKE AIR TEMPERATURE SENSOR SIGNAL
16	K2 16TN/BK	ENGINE COOLANT TEMPERATURE SENSOR SIGNAL
17	K25 18WT/BK	5-VOLT SUPPLY
18	K24 18GY/BK	CAMSHAFT POSITION SENSOR SIGNAL
19	K60 16YL/BK	IDLE AIR CONTROL NO. 2 DRIVER
20	K39 16GY/RD	IDLE AIR CONTROL NO. 1 DRIVER
21	-	-
22	F5 14RD/YL	FUSED B(+)
23	K22 18OR/DB	THROTTLE POSITION SENSOR SIGNAL
24	K41 18BK/OR	UPSTREAM HEATED OXYGEN SENSOR SIGNAL
25	K141 18BK/PK	DOWNSTREAM HEATED OXYGEN SENSOR SIGNAL
26	-	-
27	K70 18RD/WT	MAP SENSOR SIGNAL
28	-	-
29	-	-
30	-	-
31	Z12 14BK/TN	GROUND
32	Z12 14BK/TN	GROUND



**POWERTRAIN
CONTROL
MODULE - C2**

CAV	CIRCUIT	FUNCTION
1	T54 18VT	TRANSMISSION TEMPERATURE SENSOR SIGNAL
2	K17 18DB/WT*	INJECTOR NO. 7 DRIVER
3	-	-
4	K11 18WT/DB	INJECTOR NO. 1 DRIVER
5	K13 18YL/WT	INJECTOR NO. 3 DRIVER
6	K38 18GY	INJECTOR NO. 5 DRIVER
7	-	-
8	T59 18PK	UNDERDRIVE SOLENOID CONTROL
9	-	-
10	K20 18DG	GENERATOR FIELD DRIVER
11	T22 18DG/LB	TORQUE CONVERTER CLUTCH SOLENOID CONTROL
12	K58 18BR/YL	INJECTOR NO. 6 DRIVER
13	K18 18DB/YL*	INJECTOR NO. 8 DRIVER
14	-	-
15	K12 18TN	INJECTOR NO. 2 DRIVER
16	K14 18LB/BR	INJECTOR NO. 4 DRIVER
17	-	-
18	-	-
19	-	-
20	-	-
21	T60 18BR	OVERDRIVE SOLENOID CONTROL
22	-	-
23	G6 18GY/WT	OIL PRESSURE SENSOR SIGNAL
24	-	-
25	T13 18DB/BK	OUTPUT SHAFT SPEED SENSOR SIGNAL (-)
26	-	-
27	G7 18WT/OR	VEHICLE SPEED SENSOR SIGNAL
28	T14 18LG/WT	OUTPUT SHAFT SPEED SENSOR SIGNAL (+)
29	T25 18LG	GOVERNOR PRESSURE SIGNAL
30	T66 18BR/OR	TRANSMISSION RELAY CONTROL
31	K6 18VT/WT	5-VOLT SUPPLY
32	-	-

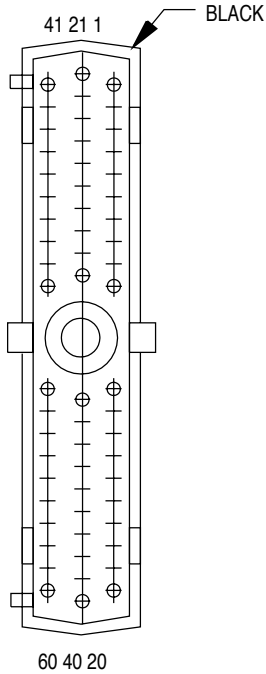
* 5.2L/5.9L



**POWERTRAIN
CONTROL
MODULE - C3**

CAV	CIRCUIT	FUNCTION
1	C13 18DB/RD	A/C COMPRESSOR CLUTCH RELAY CONTROL
2	-	-
3	K900 18PK/WT	AUTOMATIC SHUTDOWN RELAY CONTROL
4	V36 18TN/RD	SPEED CONTROL VACUUM SOLENOID CONTROL
5	V35 18LG/RD	SPEED CONTROL VENT SOLENOID CONTROL
6	G68 18BR/YL	OVERDRIVE OFF LAMP DRIVER
7	-	-
8	-	-
9	-	-
10	J95 18DG/RD*	LEAK DETECTION PUMP SOLENOID CONTROL
11	V32 18YL/RD	SPEED CONTROL ON/OFF SWITCH SENSE
12	A142 18DG/OR	AUTOMATIC SHUTDOWN RELAY OUTPUT
13	T9 18OR	OVERDRIVE OFF SWITCH SENSE
14	J96 18VT/RD*	LEAK DETECTION PUMP SWITCH SENSE
15	T222 18RD/YL	BATTERY TEMPERATURE SENSE SIGNAL
16	-	-
17	-	-
18	-	-
19	K81 18DB	FUEL PUMP RELAY CONTROL
20	K52 18PK/BK	EVAPORATIVE EMISSION SOLENOID CONTROL
21	-	-
22	C3 18DB/BK	A/C PRESSURE SWITCH SENSE
23	-	-
24	L53 18BR	STOP LAMP SWITCH SENSE
25	K72 18DG/VT	GENERATOR DRIVER
26	G40 18LB/BK	LOW FUEL SENSE
27	D21 18BK/PK	SCI RECEIVE
28	D2 18WT/BK	CCD BUS (-)
29	D84 18BK/WT	SCI TRANSMIT
30	D1 18VT/BR	CCD BUS (+)
31	-	-
32	K95 18PK	VEHICLE SPEED CONTROL SWITCH SIGNAL

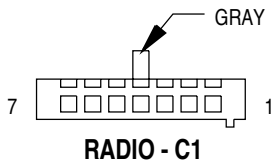
* EXCEPT BUILT-UP-EXPORT



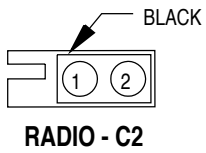
**POWERTRAIN
CONTROL
MODULE - C4
(DIESEL)**

CAV	CIRCUIT	FUNCTION
1	G40 18LB/BK	LOW FUEL SENSE
3	F6 18WT/RD	FUSED B(+)
4	K167 20BR/YL	SENSOR RETURN
6	K7 20OR/WT	5-VOLT SUPPLY
8	G18 20PK/BK	COOLANT LEVEL SWITCH SENSE
9	F99 18OR	FUSED IGNITION SWITCH OUTPUT (ST-RUN)
11	Z12 16BK/TN	POWER GROUND
12	Z12 16BK/TN	POWER GROUND
15	G69 20BK/OR	VTSS INDICATOR LAMP DRIVER
20	K20 18DG/YL	GENERATOR FIELD DRIVER
21	K222 20TN/RD	ENGINE COOLANT TEMPERATURE SENSOR SIGNAL
22	K48 18OR/RD	FLT SIGNAL
23	G123 20DG/WT	WATER-IN-FUEL SENSE
24	G21 20GY/LB	TACHOMETER SIGNAL
25	D83 20BK/PK	SCI RECEIVE
26	D1 18VT/BR	CCD BUS(+)
29	L53 20BR	STOP LAMP SWITCH SENSE
41	K92 20PK	COIL DRIVER 2 OUTPUT
42	G60 20GY/YL	ENGINE OIL PRESSURE SENSOR SIGNAL
44	K185 18OR/LB	WAIT TO START LAMP
45	D84 20BK/WT	SCI TRANSMIT
46	D2 18WT/GY	CCD BUS(-)
47	G7 20WT/OR	VEHICLE SPEED SENSOR SIGNAL
54	G118 20PK/DB	
57	A142 16DG/OR	AUTOMATIC SHUT DOWN RELAY OUTPUT
59	C103 20DG	A/C SWITCH SIGNAL

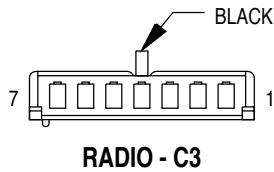
(CAVITIES NOT SHOWN ARE NOT USED)



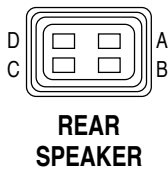
CAV	CIRCUIT	FUNCTION
1	-	-
2	X55 20BR/RD	FRONT DOOR SPEAKER (-)
3	X56 20DB	FRONT DOOR SPEAKER (-)
4	L90 20DB/RD	PARK LAMP RELAY OUTPUT
5	E2 20OR	PANEL LAMP DRIVER
6	X12 18RD/GY	FUSED IGNITION SWITCH OUTPUT (RUN-ACC)
7	F60 20RD/WT	FUSED B(+)



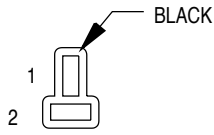
CAV	CIRCUIT	FUNCTION
1	D1 18VT/BR	CCD BUS (+)
2	D2 18WT/BK	CCD BUS (-)



CAV	CIRCUIT	FUNCTION
1	X60 20DG/RD	RADIO 12-VOLT OUTPUT
2	X51 20BR/YL	REAR DOOR SPEAKER (+)
3	X52 20DB/WT	REAR DOOR SPEAKER (+)
4	X53 20DG	FRONT DOOR SPEAKER (+)
5	X54 20VT/YL	FRONT DOOR SPEAKER (+)
6	X57 20BR/LB	REAR DOOR SPEAKER (-)
7	X58 20DB/OR	REAR SPEAKER DOOR (-)

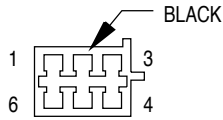


CAV	CIRCUIT	FUNCTION
A	X96 16DB/OR	AMPLIFIED HIGH RIGHT REAR SPEAKER (-)
B	X98 16DB/WT	AMPLIFIED HIGH RIGHT REAR SPEAKER (+)
C	X97 16BR/LB	AMPLIFIED HIGH LEFT REAR SPEAKER (-)
D	X95 16BR/YL	AMPLIFIED HIGH LEFT REAR SPEAKER (+)



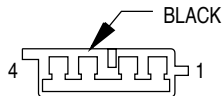
REAR WASHER PUMP MOTOR

CAV	CIRCUIT	FUNCTION
1	V20 18WT/BK	REAR WASHER MOTOR CONTROL
2	Z2 18BK	GROUND



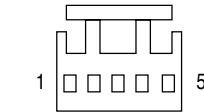
REAR WIPER MODULE

CAV	CIRCUIT	FUNCTION
1	F70 16PK/BK	FUSED (B+)
2	V13 18BR/LG	REAR WIPER MOTOR CONTROL
3	Z1 14BK	GROUND
4	V24 18BR/OR	WIPER SWITCH B(-)
5	V20 18BK/WT	REAR WASHER MOTOR CONTROL
6	G78 20TN/BK	LIFTGATE AJAR SWITCH SENSE



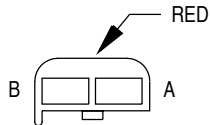
REAR WIPER/WASHER SWITCH

CAV	CIRCUIT	FUNCTION
1	V13 18BR/LG	REAR WIPER MOTOR CONTROL
2	V23 18BR/PK	FUSED IGNITION SWITCH OUTPUT (RUN-ACC)
3	V24 18BR/OR	REAR WIPER MOTOR CONTROL (INT)
4	V20 18WT/BK	REAR WASHER MOTOR CONTROL
	V20 18WT/BK	REAR WASHER MOTOR CONTROL



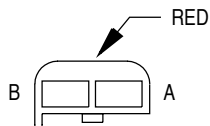
RECIRCULATION DOOR ACTUATOR (AUTOMATIC TEMPERATURE CONTROL)

CAV	CIRCUIT	FUNCTION
1	C33 20VT/OR	RECIRCULATION DOOR MOTOR DRIVER
2	-	-
3	-	-
4	C32 20LB/DG	RECIRCULATION DOOR MOTOR DRIVER
5	F71 20PK/DG	FUSED IGNITION SWITCH OUTPUT (RUN)



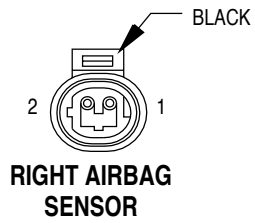
REMOTE RADIO SWITCH NO. 1

CAV	CIRCUIT	FUNCTION
A	709 20RD/BK	RADIO CONTROL MUX
B	Z2 20BK/LG	GROUND

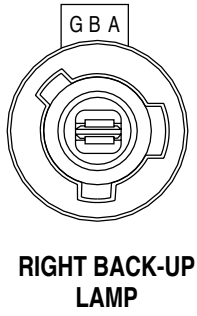


REMOTE RADIO SWITCH NO. 2

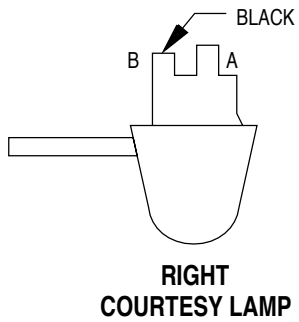
CAV	CIRCUIT	FUNCTION
A	709 20RD/BK	RADIO CONTROL MUX
B	Z2 20BK/LG	GROUND



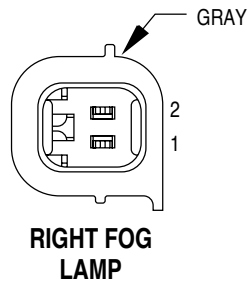
CAV	CIRCUIT	FUNCTION
1	R46 18BR/LB	RIGHT IMPACT SENSOR LINE 1
2	R48 18TN	RIGHT IMPACT SENSOR LINE 2



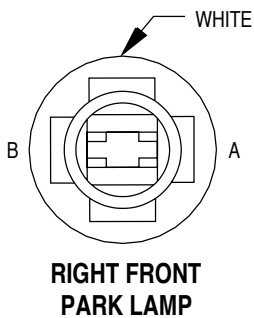
CAV	CIRCUIT	FUNCTION
A	L10 18BR/LG	BACK-UP LAMP SWITCH OUTPUT
G	Z1 18BK	GROUND



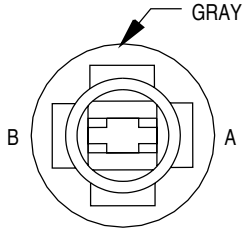
CAV	CIRCUIT	FUNCTION
A	M1 20PK	FUSED B(+)
B	M2 20YL	COURTESY LAMP RELAY OUTPUT



CAV	CIRCUIT	FUNCTION
1	Z1 18BK	GROUND
2	L39 18LB	FOG LAMP RELAY OUTPUT

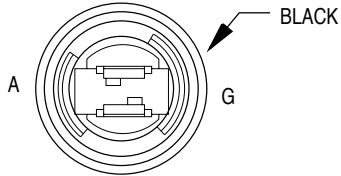


CAV	CIRCUIT	FUNCTION
A	L90 18DB/RD	PARK LAMP RELAY OUTPUT
B	Z1 18BK	GROUND



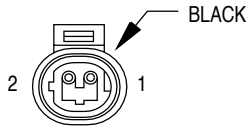
**RIGHT FRONT
SIDE MARKER
LAMP**

CAV	CIRCUIT	FUNCTION
A	L90 18DB/RD	PARK LAMP RELAY OUTPUT
B	Z1 18BK	GROUND



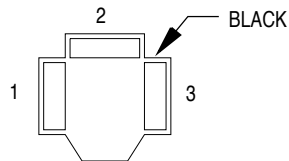
**RIGHT FRONT
TURN SIGNAL
LAMP**

CAV	CIRCUIT	FUNCTION
A	L64 18TN/DB	RIGHT TURN SIGNAL
G	Z1 18BK	GROUND



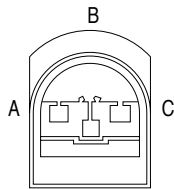
**RIGHT FRONT
WHEEL SPEED
SENSOR**

CAV	CIRCUIT	FUNCTION
1	B6 18WT/DB	RIGHT FRONT WHEEL SPEED SENSOR (-)
2	B7 18WT	RIGHT FRONT WHEEL SPEED SENSOR (+)



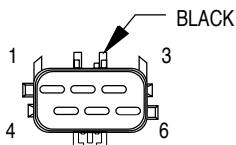
RIGHT HEADLAMP

CAV	CIRCUIT	FUNCTION
1	L3 16RD/OR	DIMMER SWITCH HIGH BEAM OUTPUT
2	L4 16VT/OR	DIMMER SWITCH LOW BEAM OUTPUT
3	Z1 16BK	GROUND



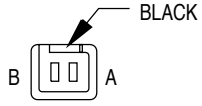
**RIGHT HEADLAMP
(EXCEPT BUILT-
UP-EXPORT)**

CAV	CIRCUIT	FUNCTION
A	Z1 16BK	GROUND
B	L4 16VT/OR	DIMMER SWITCH LOW BEAM OUTPUT
C	L3 16RD/OR	DIMMER SWITCH HIGH BEAM OUTPUT



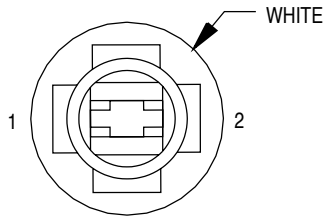
**RIGHT HEADLAMP
LEVELING MOTOR**

CAV	CIRCUIT	FUNCTION
1	L104 20LG	HEADLAMP LEVELING POSITION 4
2	L103 20LB	HEADLAMP LEVELING POSITION 3
3	L102 20WT	HEADLAMP LEVELING POSITION 2
4	L105 20PK	HEADLAMP LEVELING POSITION 5
5	L106 20YL	HEADLAMP LEVELING POSITION 6
6	L101 20RD	HEADLAMP LEVELING POSITION 1



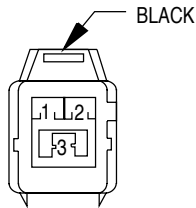
**RIGHT INSTRUMENT
PANEL SPEAKER**

CAV	CIRCUIT	FUNCTION
A	X82 20LB/RD	AMPLIFIED RIGHT FRONT (+)
B	X80 20LB/BK	AMPLIFIED RIGHT FRONT (-)



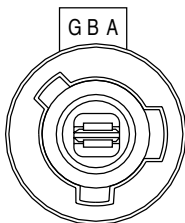
**RIGHT LICENSE
LAMP**

CAV	CIRCUIT	FUNCTION
1	L90 20DB/RD	PARK LAMP RELAY OUTPUT
2	Z1 20BK	GROUND



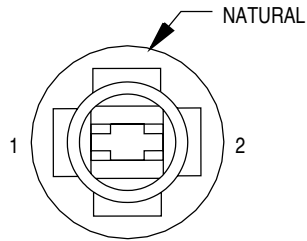
**RIGHT PARK/
TURN SIGNAL
MARKER**

CAV	CIRCUIT	FUNCTION
1	L64 18TN/DB	RIGHT TURN SIGNAL
2	L90 18DB/RD	PARK LAMP SWITCH OUTPUT
3	Z1 18BK	GROUND



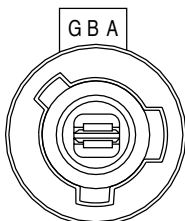
**RIGHT REAR
FOG LAMP
(BUILT-UP-EXPORT)**

CAV	CIRCUIT	FUNCTION
A	L36 18LG/BK	REAR FOG LAMP
G	Z1 18BK	GROUND



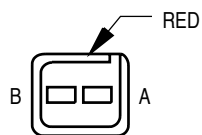
**RIGHT REAR
SIDE MARKER
LAMP
(BUILT-UP-EXPORT)**

CAV	CIRCUIT	FUNCTION
1	Z1 18BK	GROUND
2	L22 18LB	PARK LAMP SWITCH OUTPUT



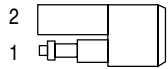
**RIGHT REAR
TURN SIGNAL
LAMP**

CAV	CIRCUIT	FUNCTION
A	L61 18LG	TURN SIGNAL SWITCH OUTPUT
G	Z1 18BK	GROUND



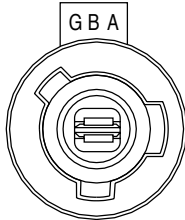
**RIGHT REAR
WHEEL SPEED
SENSOR**

CAV	CIRCUIT	FUNCTION
A	B1 20YL/DB	RIGHT REAR WHEEL SPEED SENSOR (-)
B	B2 20YL	RIGHT REAR WHEEL SPEED SENSOR (+)



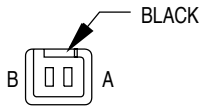
RIGHT SIDE REPEATER

CAV	CIRCUIT	FUNCTION
1	Z1 18BK	GROUND
2	L64 18TN/DB	RIGHT TURN SIGNAL



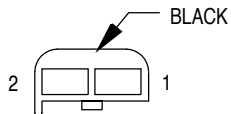
RIGHT TAIL/ STOP LAMP

CAV	CIRCUIT	FUNCTION
A	L74 18PK/BK	STOP LAMP SWITCH OUTPUT
B	L22 18LB	PARK LAMP SWITCH OUTPUT
G	Z1 18BK	GROUND



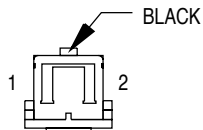
RIGHT VISOR/ VANITY LAMP

CAV	CIRCUIT	FUNCTION
A	M1 20PK	FUSED B(+)
B	Z1 20BK	GROUND



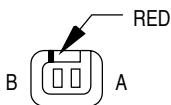
SEAT BELT SWITCH

CAV	CIRCUIT	FUNCTION
1	G10 20LG/RD	SEAT BELT SWITCH SENSE
2	Z1 20BK	GROUND



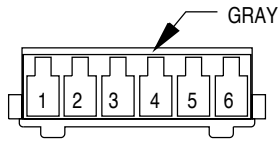
SHIFT INTERLOCK

CAV	CIRCUIT	FUNCTION
1	L53 20BR	SHIFT INTERLOCK SOLENOID SENSE
2	F87 20BK/WT	FUSED IGNITION SWITCH OUTPUT (ST-RUN)



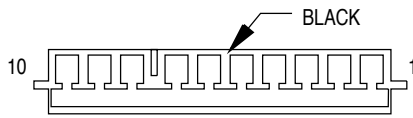
SOLAR SENSOR

CAV	CIRCUIT	FUNCTION
A	C47 20BK/WT	SOLAR SENSOR SIGNAL
B	D41 20LG/WT	SENSOR GROUND



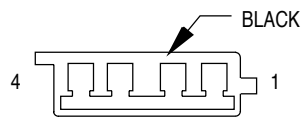
STOP LAMP SWITCH

CAV	CIRCUIT	FUNCTION
1	L53 20BR	STOP LAMP SWITCH SENSE
2	Z1 20BK	GROUND
3	V32 20YL/RD	SPEED CONTROL ON/OFF SWITCH SENSE
4	V30 20DB/LG	SPEED CONTROL ON/OFF SWITCH OUTPUT
5	L50 18WT/TN	BRAKE LAMP SWITCH OUTPUT
6	L16 18RD/LG	FUSED B(+)



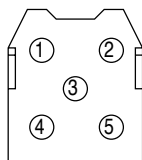
SWITCH POD

CAV	CIRCUIT	FUNCTION
1	P7 20LB*	DRIVER HEATED SEAT SWITCH OUTPUT
2	Z1 20BK	GROUND
3	E2 20OR	PANEL LAMP DRIVER
4	P8 20LB/WT*	PASSENGER HEATED SEAT SWITCH OUTPUT
5	F71 20PK/DG	FUSED IGNITION SWITCH OUTPUT (RUN)
6	T9 20OR/BK	OVERDRIVE OFF SWITCH SENSE
7	G68 20BR/YL	OVERDRIVE OFF LAMP DRIVER
8	-	-
9	C80 20DB/YL	REAR WINDOW DEFOGGER SWITCH SENSE
10	C16 20LB/YL	FUSED REAR WINDOW DEFOGGER RELAY OUTPUT



SUNROOF CONTROL MODULE

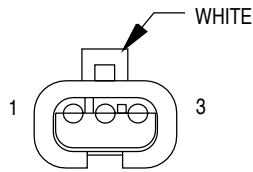
CAV	CIRCUIT	FUNCTION
1	Z1 16BK	GROUND
2	Q41 16WT	POWER SUNROOF OPEN
3	Q42 16LB	POWER SUNROOF CLOSE
4	F86 16LG/BK	FUSED IGNITION SWITCH OUTPUT (RUN-ACC)



SUNROOF SWITCH

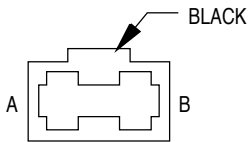
CAV	CIRCUIT	FUNCTION
1	Q41 16WT	POWER SUNROOF OPEN
2	F86 16LG/BK	FUSED IGNITION SWITCH OUTPUT (RUN-ACC)
3	Q42 16LB	POWER SUNROOF CLOSE
4	-	-
5	-	-

* HEATED SEATS



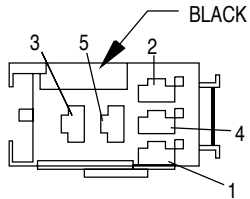
THROTTLE POSITION SENSOR

CAV	CAV	CIRCUIT	FUNCTION
•3	*1	K25 20WT/BK	5-VOLT SUPPLY
•2	*2	K22 18OR/DB	THROTTLE POSITION SENSOR SIGNAL
•1	*3	K4 20BK/LB	SENSOR GROUND



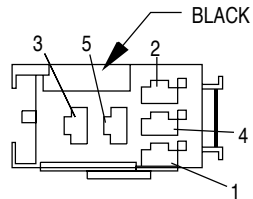
TRAILER TOW CIRCUIT BREAKER

CAV	CIRCUIT	FUNCTION
A	F70 16PK/BK	FUSED B(+)
B	F70 16PK/BK	FUSED B(+)



TRAILER TOW LEFT TURN RELAY

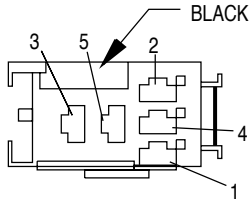
CAV	CIRCUIT	FUNCTION
1	L61 18LG	LEFT TURN SIGNAL
2	Z1 18BK	GROUND
3	L61 18LG/OR	LEFT TURN SIGNAL
4	95 18PK	FACTORY TRAILER TOW RELAY OUTPUTS
	95 18PK	FACTORY TRAILER TOW RELAY OUTPUTS
5	94 18DG	FACTORY TRAILER TOW RELAY OUTPUTS
	94 18DG	FACTORY TRAILER TOW RELAY OUTPUTS



TRAILER TOW RIGHT TURN RELAY

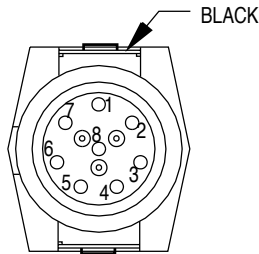
CAV	CIRCUIT	FUNCTION
1	L60 18TN	RIGHT TURN SIGNAL
2	Z1 18BK	GROUND
3	L60 18TN/OR	RIGHT TURN SIGNAL
4	95 18PK	FACTORY TRAILER TOW RELAY OUTPUTS
5	94 18DG	FACTORY TRAILER TOW RELAY OUTPUTS
6	-	-
7	-	-
8	-	-

* 5.2L/5.9L
• 4.0L



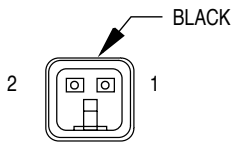
**TRAILER TOW
STOP LAMP RELAY**

CAV	CIRCUIT	FUNCTION
1	L50 18WT/TN	BRAKE LAMP SWITCH OUTPUT
2	Z1 18BK	GROUND
3	F70 16PK/BK	FUSED B(+)
4	94 18DG	FACTORY TRAILER TOW RELAY OUTPUTS
5	95 18PK	FACTORY TRAILER TOW RELAY OUTPUTS



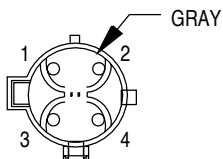
**TRANSMISSION
SOLENOID
ASSEMBLY**

CAV	CIRCUIT	FUNCTION
1	T20 18LB	LOW/REVERSE SOLENOID CONTROL
2	K6 18VT/WT	5 VOLT SUPPLY
3	K4 18BK/LB	SENSOR GROUND
4	T25 18LG	GOVERNOR PRESSURE SIGNAL
5	T59 18PK	UNDERDRIVE SOLENOID CONTROL
6	T60 18BR	OVERDRIVE SOLENOID CONTROL
7	T22 18DG/LB	TORQUE CONVERTER CLUTCH SOLENOID CONTROL
8	T54 18VT	TRANSMISSION TEMPERATURE SENSOR SIGNAL



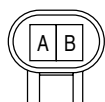
UNDERHOOD LAMP

CAV	CIRCUIT	FUNCTION
1	M1 18PK	FUSED B(+)
2	Z1 18BK	GROUND



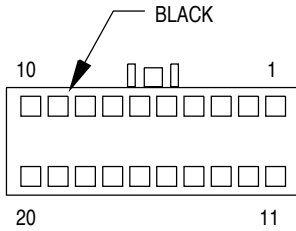
**UPSTREAM
HEATED OXYGEN
SENSOR**

CAV	CIRCUIT	FUNCTION
1	A142 18DG/OR	AUTOMATIC SHUTDOWN RELAY OUTPUT
2	Z12 18BK/TN	GROUND
3	K4 18BK/LB	SENSOR GROUND
4	K41 18BK/OR	UPSTREAM HEATED OXYGEN SENSOR SIGNAL



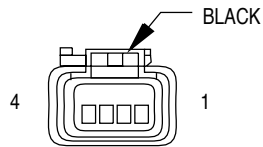
**UPPER HOSE
COOLANT SWITCH
(MAX COOLING)**

CAV	CIRCUIT	FUNCTION
A	C4 16TN/BK	COOLING FAN RELAY CONTROL
B	Z1 16BK	GROUND



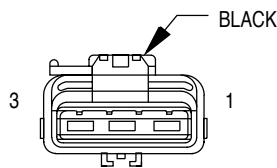
**VEHICLE
INFORMATION CENTER/
GRAPHIC DISPLAY
MODULE**

CAV	CIRCUIT	FUNCTION
1	G18 20PK/BK	ENGINE COOLANT LEVEL SWITCH SENSE
2	F60 20RD/WT	FUSED B(+)
3	Z2 20BK/OR	GROUND
4	L5 18OR/BK	TURN SIGNAL
5	G46 20BK/LB	REAR LAMP OUT INDICATOR DRIVER
6	-	-
7	D1 18VT/BR	CCD BUS (+)
8	D2 18WT/BK	CCD BUS (-)
9	-	-
10	E2 20OR	PANEL LAMP DRIVER
11	L90 20DB/RD	PARK LAMP RELAY OUTPUT
12	-	-
13	G29 20BK/TN	WASHER FLUID LEVEL SENSE
14	107 20BK/RD	4-WHEEL DRIVE PART TIME LAMP
15	T106 20GY/OR	4-WHEEL DRIVE FULL TIME LAMP
16	F83 18YL/DG	FUSED IGNITION SWITCH OUTPUT (RUN)
17	T19 20YL/BK	4-WHEEL DRIVE PART TIME LAMP
18	G42 20LB/RD	ALL TIME FRONT WHEELS
19	G28 20LG/OR	2-WHEEL DRIVE OR REAR WHEELS IN ALL TIME
20	Z1 20BK	GROUND



**VEHICLE SPEED
CONTROL SERVO**

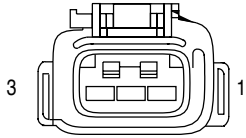
CAV	CIRCUIT	FUNCTION
1	V36 18TN/RD	SPEED CONTROL VACUUM SOLENOID CONTROL
2	V35 18LG/RD	SPEED CONTROL VENT SOLENOID CONTROL
3	V30 20DB/LG	SPEED CONTROL ON/OFF SWITCH OUTPUT
4	Z4 20BK	GROUND



**VEHICLE SPEED
SENSOR
(GAS)**

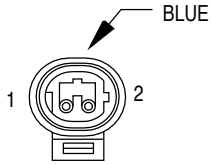
CAV	CIRCUIT	FUNCTION
1	K6 18VT/WT**	5-VOLT SUPPLY
1	G7 18WT/OR*	VEHICLE SPEED SENSOR SIGNAL
2	K4 18BK/LB	SENSOR GROUND
3	G7 18WT/OR**	VEHICLE SPEED SENSOR SIGNAL
3	K6 18VT/WT*	5-VOLT SUPPLY

* LHD
** RHD



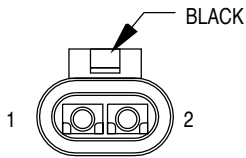
VEHICLE SPEED SENSOR (DIESEL)

CAV	CIRCUIT	FUNCTION
1	K7 20OR/WT	5 VOLT SUPPLY
2	K167 20BR/YL	SENSOR RETURN
3	G7 20WT/OR	VEHICLE SPEED SENSOR SIGNAL



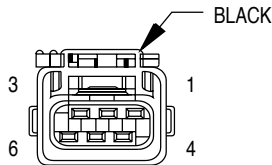
WATER IN FUEL SENSOR (DIESEL)

CAV	CIRCUIT	FUNCTION
1	G123 20DG/WT	WATER IN FUEL SENSE
2	K167 20BR/YL	SENSOR RETURN



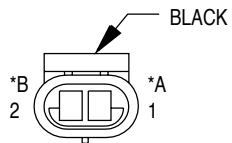
WINDSHIELD WASHER PUMP MOTOR

CAV	CIRCUIT	FUNCTION
1	V11 18TN/BK	WASHER SWITCH OUTPUT
2	Z2 18BK	GROUND



WINDSHIELD WIPER MOTOR

CAV	CIRCUIT	FUNCTION
1	F86 16LG/RD	FUSED IGNITION SWITCH OUTPUT (RUN-ACC)
2	V66 18VT/WT	WIPER PARK SWITCH SENSE
3	-	-
4	Z2 18BK	GROUND
5	V3 18BR/WT	WIPER SWITCH LOW SPEED OUTPUT
6	V4 18RD/YL	WIPER SWITCH HIGH SPEED OUTPUT



WIPER FLUID LEVEL SENSOR

CAV	CIRCUIT	FUNCTION
1	G29 16BK/TN	WASHER FLUID LEVEL SENSE
2	Z2 16BK	GROUND
A	G29 16BK/TN*	WASHER FLUID LEVEL SENSE
B	Z2 16BK*	GROUND

* DIESEL

8W-90 CONNECTOR LOCATIONS

DESCRIPTION AND OPERATION

INTRODUCTION

This section provides illustrations identifying component and connector locations in the vehicle. A connector index is provided. Use the wiring diagrams in each section for connector number identification. Refer to the index for the proper figure number.

CONNECTOR/GROUND LOCATIONS (LHD)

For items that are not shown in this section N/S is placed in the Fig. column.

Connector Name/Number	Color	Location	Fig.
A/C Compressor Clutch	BK	Near Compressor	6,9, 12
A/C Heater Control	BK	Rear of Switch	N/S
A/C High Pressure Switch	BK	Near A/C Compressor	6,8, 12
A/C Low Pressure Switch	BK	Right Rear Corner of Engine Compartment	2
After Market Trailer Tow Connector	BK	Left Rear Quarter Panel	N/S
Airbag Control Module	YL	Below Center Floor Console, Near Park Brake	20
Ambient Temperature Sensor	BK	On Radiator Center Support	1
Auto Headlamp Light Sensor VTSS LED	BK	Top of Instrument Panel, Between Steering Column and Center Floor Console	15
Automatic Day/Night Rearview Mirror	BK	Behind Rear View Mirror	19
Automatic Temperature Control Module	BK	Left Side of HVAC Housing	N/S
Back-Up Lamp Switch	BK	Right Side of Transmission	14

Connector Name/Number	Color	Location	Fig.
Battery Temperature Sensor	BK	Below Battery Tray	4
Blend Air Door Motor	BK	On Bottom of HVAC Unit	N/S
Blend Air Actuator	BK	On Bottom of HVAC Unit	N/S
Blower Motor	NAT	Right Side of HVAC	N/S
Blower Motor Resistor Block	BK	Right Side of HVAC	N/S
Blower Motor Switch	BK	On HVAC Unit	N/S
Blower Power Module	BK	On HVAC Unit	N/S
Body Control Module C1	BK	Lower Left of Instrument Panel	17
Body Control Module C2	WT	Lower Left of Instrument Panel	17
Body Control Module C3	BK	Lower Left of Instrument Panel	17
Brake Pressure Switch	BK	Right Fender Side Shield, Near Brake Master Cylinder	3
Brake Shift Interlock	BK	Top of Brake Pedal	N/S
C102	BK	Rear of Left Headlamp	1

DESCRIPTION AND OPERATION (Continued)

Connector Name/Number	Color	Location	Fig.
C131	BK	Right Rear Corner of Engine Compartment, Near PCM	2
C132	BK	Right Rear Corner of Engine Compartment, Near PCM	2
C144	BK	Below PDC	6,13
C150	BK	Rear of Right Headlamp	1
C159	BK	Right Rear Corner of Engine Compartment	25
C160	BK	Right Corner of Instrument Panel	16
C170	BK	Near PDC	N/S
C182	BK	Under Rear Seat	N/S
C206	BK	On Front of HVAC Unit	16
C212	RD	Center of Instrument Panel	14
C231	BK	Right End of Instrument Panel	N/S
C233	BK	Lower Left of Instrument Panel, In Connector Bracket	17
C234	WT	Lower Left of Instrument Panel, In Connector Bracket	17
C235	BK	Lower Left of Instrument Panel, In Connector Bracket	17

Connector Name/Number	Color	Location	Fig.
C236	WT	Lower Left of Instrument Panel, In Connector Bracket	17
C300	YL	Lower Left of Instrument Panel	17
C301	NAT	Lower Left of Instrument Panel, In Connector Bracket	17
C302	WT	Lower Left of Instrument Panel, In Connector Bracket	17
C304	GY	Lower Left of Instrument Panel	N/S
C305	BK	Lower Left of Instrument Panel, In Connector Bracket	17
C307	BK	Lower Left of Instrument Panel	17
C309	GY	In Left Rear Door	23
C320	GY	Right Rear Quarter Panel, Near Bottom of Liftgate Opening	20
C321	BK	In Liftgate	25
C322	GN	In Liftgate	25
C323	GY	In Liftgate	25
C324	BK	In Liftgate	25
C325	BK	In Liftgate	25
C326	GY	In Liftgate	25
C328	GY	Left Rear Quarter Panel, Near Bottom of Liftgate Opening	21

DESCRIPTION AND OPERATION (Continued)

Connector Name/Number	Color	Location	Fig.
C329	BK	Below Left Rear Passenger Seat	21
C330	GY	In Right Rear Door	23
C331	BK	Left Rear Quarter Panel	24
C334	BK	In Left Front Door	22
C335	BK	Below Left Rear Passenger Seat	20
C343	BK	In Left Rear Door	23
C345	BK	In Right Rear Door	23
C351	GY	In Right Front Door	22
C353	BK	In Left Front Door	22
C359	BK	In Liftgate	25
C364	BK	In Liftgate	25
C372	BK	Right Rear Quarter Panel	24
C380	BK	Left Rear Quarter Panel	N/S
Camshaft Position Sensor	BK	Near Distributor	5, 9
Cargo Lamp	BK	Rear of Cargo Lamp	21
Center High Mounted Stop Lamp Bulb No. 1	BK	At Lamp	N/S
Center High Mounted Stop Lamp Bulb No. 2	BK	At Lamp	N/S
Center High Mounted Stop Lamp Bulb No. 3	BK	At Lamp	N/S
Cigar Lighter	BK	Rear of Cigar Lighter	15
Clockspring	YL	Below Steering Column	3

Connector Name/Number	Color	Location	Fig.
Controller Anti-Lock Brake	BK	At Anti-Lock Brake Controller	N/S
Coolant Switch-Upper Hose (5.2L/ 5.9L)	BK	Upper Radiator Hose	11
Coolant Switch-Lower Hose (5.2L/ 5.9L)	BK	Lower Radiator Hose	11
Cooling Fan	BK	At Fan	11
Cooling Fan Relay	BK	Right Fender Side Shield	11
Crankshaft Position Sensor	BK	Right Rear of Engine 4.0L Engine Rear of Engine 5.2L Engine Rear of Engine 2.5L	5,9, 14
Data Link Connector	BK	Lower Left of Instrument Panel	15
Daytime Running Lamp Module	BK	Right Fender Side Shield, Below PDC	2
Dome/Reading Lamp	NAT	Behind Dome Lamp	19
Downstream Heated Oxygen Sensor	BK	Above Rear of Catalytic Converter	7,10
Driver Door Module C1	WT	In Left Front Door	22
Driver Heated Seat Back	BK	Under Driver's Seat	N/S
Driver Heated Seat Cushion	BK	Under Driver's Seat	N/S
Driver Lumbar Motor	BK	Under Driver's Seat	N/S
Driver Power Seat Front Riser Motor	RD	Under Driver's Seat	N/S
Driver Power Seat Front Riser Motor Sensor	BK	Under Driver's Seat	N/S
Driver Power Seat Horizontal Motor	BK	Under Driver's Seat	N/S

DESCRIPTION AND OPERATION (Continued)

Connector Name/Number	Color	Location	Fig.
Driver Power Seat Horizontal Motor Sensor	BK	Under Driver's Seat	N/S
Driver Power Seat Lumbar Motor Sensor	BK	Under Driver's Seat	N/S
Driver Power Seat Lumbar Switch	BK	Under Driver's Seat	N/S
Driver Power Seat Rear Riser Motor	RD	Under Driver's Seat	N/S
Driver Power Seat Rear Riser Motor Sensor	BK	Under Driver's Seat	N/S
Driver Power Seat Recliner Motor	BK	Under Driver's Seat	N/S
Driver Power Seat Recliner Motor Sensor	BK	Under Driver's Seat	N/S
Driver Power Seat Switch	GN	Under Driver's Seat	N/S
Driver Seat Heater Control Module	BK	Under Driver's Seat	N/S
Duty Cycle EVAP/Purge Solenoid	BK	Front of Left Fender Side Shield	3
Electric Vacuum Modulator	BK	Under PDC	13
Engine Coolant Level Sensor	BK	Right Rear Corner of Engine Compartment	2
Engine Coolant Temperature Sensor	BK	On Thermostat Housing Rear of Generator	5,8, 12
Engine Oil Pressure Sensor	BK	Near Distributor (Gas) Left Side of Engine (Diesel)	5,9, 13
Engine Speed Sensor	BK	Top of Transmission	14
Engine Starter Motor	BK	At Starter Motor	6, 8
Engine Starter Motor Jumper		At Starter Motor	13

Connector Name/Number	Color	Location	Fig.
Factory Trailer Tow Connector	BK	On Trailer Hitch	24
Floor Console Lamps	BK	Left Side of Center Floor Console	20
Four-Wheel Drive Switch	BK	Left Front of Transfer Case	7, 10,14
Fuel Heater	BK	At Fuel Heater/Filter	12
Fuel Injector #1	GY	At Injector	5,9
Fuel Injector #2	GY	At Injector	5,8
Fuel Injector #3	GY	At Injector	5,9
Fuel Injector #4	GY	At Injector	5,8
Fuel Injector #5	GY	At Injector	5,9
Fuel Injector #6	GY	At Injector	5,8
Fuel Injector #7	GY	At Injector	9
Fuel Injector #8	GY	At Injector	8
Fuel Pump (Diesel)	BK	At Pump	12
Fuel Pump Module	BK	Near Fuel Tank	20, 21
G100		Right Fender Side Shield	2
G101		Right Side of Engine Block 4.0L Engine Below Generator 5.2L Engine Right Front of Engine 2.5L	6,8, 13
G103		Right Side of Engine Block 4.0L Engine Below Generator 5.2L Engine	6, 8
G104		Right Side of Engine Block 4.0L Engine	6
G104		Below Generator 5.2L Engine	8
G104		Below A/C Compressor Diesel Engine	12

DESCRIPTION AND OPERATION (Continued)

Connector Name/Number	Color	Location	Fig.
G105		Right Rear of Engine 4.0L Engine front of Left cylinder Head 5.2L Engine	5, 9
G106		Right Fender Side Shield	2
G107		Right Fender Side Shield	2
G108		Front of Left Fender Side Shield	3
G109		Front of Left Fender Side Shield	3
G110		Right Fender Side Shield	11
G300		Right Rear Quarter Panel	20
G301		Rear of Passenger's Seat	20
G302		On Floor Pan Rear of Driver's Seat	21
G303		On Floor Pan Rear of Driver's Seat	21
G-Switch	BK	Below Right Rear Passenger Seat	20
Generator	BK	At Generator	6,8
Glove Box Lamp	BK	At Glove Box Lamp	15
Glow Plug	BK	Left Side of Engine	12
Glow Plug Relay	BK	At PDC (Diesel Engine)	N/S
Graphic Display Module/Vehicle Information Center	BK	Rear of Vehivle Information Center (VIC)	15
Headlamp Leveling Switch	BK	At Switch	15
Headlamp Switch	BK	Rear of Headlamp Switch	15

Connector Name/Number	Color	Location	Fig.
High Speed Blower Motor Relay	BK	Right Side of HVAC	N/S
Horn No. 1	BK	At Horn, Lower Right Front of Vehicle	1
Horn No. 2	BK	At Horn, Lower Right Front of Vehicle	1
Idle Air Control Motor	BK	On Throttle Body	5, 9
Ignition Coil	BK	Right Front of Engine	5, 8
Ignition Relay	BK	In PDC	N/S
Ignition Switch	BK	On Steering Column	18
In-Car Temperature Sensor	BK	Center, Top of Instrument Panel	14
Instrument Cluster	BK	Rear of Instrument Cluster	15
Intake Air Temperature Sensor	GY	On Intake Manifold	5, 8
Junction Block - C1	BK	Behind Right Kick Panel	16
Junction Block - C2	BK	Behind Right Kick Panel	16
Junction Block - C3	BK	Behind Right Kick Panel	16
Junction Block - C4	BL*	Behind Right Kick Panel	16
Junction Block - C5	YL	Behind Right Kick Panel	16
Junction Block - C6	GY	Behind Right Kick Panel	16
Junction Block - C7	GN	Behind Right Kick Panel	16
Junction Block - C8	BK	Behind Right Kick Panel	16
Junction Block - C9	BK	Behind Right Kick Panel	16
Junction Block - C10	BK	Behind Right Kick Panel	16

DESCRIPTION AND OPERATION (Continued)

Connector Name/Number	Color	Location	Fig.
Junction Block Body Connector - C13	BK	Behind Right Kick Panel	N/S
Junction Block Body Connector - C14	BK	Behind Right Kick Panel	N/S
Key-In Switch/Halo Lamp	GY	On Steering Column, Near Ignition Switch	17
Lamp Outage Module C1	BK	Left Rear Quarter Panel, Near Bottom of Liftgate Opening	21
Lamp Outage Module C2	BK	Left Rear Quarter Panel, Near Bottom of Liftgate Opening	21
Left Back-Up Lamp	BK	At Lamp	N/S
Left Courtesy Lamp	BK	At Lamp	15
Left Front Door Courtesy Lamp	BK	In Left Front Door	22
Left Front Fog Lamp	BK	Left Fog Lamp	N/S
Left Front Cylinder Lock Switch	BK	In Left Front Door	22
Left Front Power Door Lock Motor	BK	In Left Front Door	22
Left Front Door Ajar Switch	BK	At Switch	21
Left Front Door Speaker	BK	In Left Front Door	22
Left Front Park Lamp	WT	At Lamp	N/S
Left Front Power Window Motor	BK	In Left Front Door	22
Left Front Side Marker Lamp	GY	At Lamp	N/S
Left Front Turn Signal Lamp	BK	At Lamp	N/S

Connector Name/Number	Color	Location	Fig.
Left Front Wheel Speed Sensor	BK	Left Rear Corner of Engine Compartment	3
Left Headlamp	BK	Rear of Headlamp	1
Left Headlamp Leveling Motor	BK	At Headlamp	1
Left Instrument Panel Speaker	BK	Rear of Left Instrument Panel Speaker	15
Left License Lamp	NAT	In Liftgate Behind License Plate Lamps	27
Left Rear Door Ajar Switch	BK	At Switch	21
Left Rear Door Lock Motor	BK	In Left Rear Door	23
Left Rear Door Speaker	BK	In Left Rear Door	23
Left Rear Power Window Motor	BK	In Left Rear Door	23
Left Rear Power Window switch	BL	In Left Rear Door	23
Left Rear Side Marker Lamp	NAT	At Lamp	N/S
Left Rear Turn Signal Lamp	BK	At Lamp	N/S
Left Rear Wheel Speed Sensor	BK	Below Right Rear Passenger Seat	20
Left Side Repeater Lamp	BK	At Lamp	N/S
Left Tail/Stop Lamp	BK	At Lamp	N/S
Left Visor/Vanity Mirror	BK	Top of Left A-Pillar	19
Liftgate Ajar Switch	BK	In Liftgate	25
Liftgate Cylinder Lock Switch	BK	In Liftgate	25
Liftgate Lock Motor	BK	In Liftgate	25
Liftglass Ajar Switch	BK	In Liftgate	25
Liftglass Limit Switch	NAT	In Liftgate	25

DESCRIPTION AND OPERATION (Continued)

Connector Name/Number	Color	Location	Fig.
Liftglass Push Button	BK	In Liftgate	25
Liftglass Release Solenoid	BK	In Liftgate	25
Low Washer Fluid Level Sensor	BK	Below Battery Tray	4
Manifold Absolute Pressure Sensor	BK	On Throttle Body	5, 9
Mass Airflow Sensor	BK	At Air Cleaner	N/S
Memory Seat Module Connector C1	BK	At Driver's Seat	N/S
Memory Seat Module Connector C2	BK	At Driver's Seat	N/S
Mini Overhead Console	GY	Under Passenger's Seat	N/S
Mode Door Motor	BK	Left Side of HVAC	N/S
MSA Controller	BK	At Controller	N/S
Multi-Function Switch	BK	On Steering Column	18
Needle Movement Sensor	BK	In #1 Injector	12
Output Shaft Speed Sensor	BK	Left Side of Transmission	7, 10
Overdrive Switch	BK	At Switch	15
Overhead Console	RD	Center of Headliner, Above Rear View Mirror	18
Overhead Console Junction Block	BK	Behind Right Kick Panel, At Junction Block	15
Park Brake Switch	BK	At Park Brake Lever	20
Park/Neutral Position Switch	BK	Left Side of Transmission	7, 10

Connector Name/Number	Color	Location	Fig.
Passenger Airbag	YL	Behind Passenger Airbag	14
Passenger Door Module C1	WT	In Right Front Door	N/S
Passenger Heated Seat Back	GN	Under Passenger's Seat	N/S
Passenger Heated Seat Cushion	BK	Under Passenger's Seat	N/S
Passenger Lumbar Motor	BK	Under Passenger's Seat	N/S
Passenger Lumbar Switch	WT	Under Passenger's Seat	N/S
Passenger Power Seat Front Riser Motor	RD	Under Passenger's Seat	N/S
Passenger Power Seat Horizontal Motor	BK	Under Passenger's Seat	N/S
Passenger Power Seat Rear Riser Motor	RD	Under Passenger's Seat	N/S
Passenger Power Seat Recliner Motor	BK	Under Passenger's Front Seat	N/S
Passenger Power Seat Switch	BK	Under Passenger's Front Seat	N/S
Passenger Seat Heater Control Module	GY	Under Passenger's Seat	N/S
Pedal Position Sensor	BK	At Throttle Pedal	N/S
Power Amplifier C1	WT	Below Right Rear Passenger Seat	20
Power Amplifier C2	WT	Below Right Rear Passenger Seat	20
Power Antenna Motor	BK	At Junction Block	N/S
Power Outlet	BK	Rear of Power Outlet	15

DESCRIPTION AND OPERATION (Continued)

Connector Name/Number	Color	Location	Fig.
Powertrain Control Module C1	BK	Right Rear Corner of Engine Compartment At PCM	2
Powertrain Control Module C2	WT	Right Rear Corner of Engine Compartment At PCM	2
Powertrain Control Module C3	GY	Right Rear Corner of Engine Compartment At PCM	2
Radio C1	GY	Rear of Radio	15
Radio C2	BK	Rear of Radio	15
Radio C3	BK	Rear of Radio	15
Rear Speaker	BK	Rear Door	23
Rear Washer Pump Motor	BK	Bottom of Windshield Washer Fluid Reservoir	4
Rear Wiper Motor	BK	In Liftgate	24
Rear Wiper/Washer Switch	BK	Behind Rear Wiper Switch	15
Recirculation Door Motor	YL	Top of HVAC	N/S
Right Back-Up Lamp	BK	At Lamp	N/S
Right Courtesy Lamp	BK	Right Courtesy Lamp	15
Right Door Courtesy Lamp	BK	In Right Front Door	22
Right Front Door Ajar Switch	WT	At Switch	22
Right Front Fog Lamp	BK	Rear of Fog Lamp	1
Right Front Cylinder Lock Switch	BK	In Right Front Door	22
Right Front Power Door Lock Motor	BK	In Right Front Door	22
Right Front Door Speaker	BK	In Right Front Door	22

Connector Name/Number	Color	Location	Fig.
Right Front Park Lamp	WT	At Lamp	N/S
Right Front Power Window Motor	BK	In Right Front Door	22
Right Front Turn Signal Lamp	BK	At Lamp	N/S
Right Front Wheel Speed Sensor	BK	Right Rear Corner of Engine Compartment	2
Right Headlamp	BK	Right Fog Lamp	1
Right Headlamp Leveling Motor	BK	At Headlamp	1
Right Instrument Panel Speaker	BK	Top Right of Instrument Panel	15
Right License Lamp	NAT	In Liftgate, Behind License Plate Lamps	27
Right Rear Door Ajar Switch	BK	At Switch	N/S
Right Rear Door Lock Motor	BK	In Right Rear Door	23
Right Rear Door Speaker	BK	In Right Rear Door	23
Right Rear Fog Lamp	BK	At Lamp	N/S
Right Rear Power Window Motor	BK	In Right Rear Door	23
Right Rear Power Window Switch	BL	In Right Rear Door	23
Right Rear Side Marker Lamp	NAT	At Lamp	N/S
Right Rear Speaker	BK	At Speaker	N/S
Right Rear Turn Signal Lamp	BK	At Lamp	N/S
Right Rear Wheel Speed Sensor	RD	Below Right Rear Passenger Seat	20
Right Side Repeater Lamp	BK	At Lamp	N/S
Right Tail/Stop Lamp	BK	At Lamp	N/S

DESCRIPTION AND OPERATION (Continued)

Connector Name/Number	Color	Location	Fig.
Right Visor/ Vanity Mirror	BK	Top of Right A-Pillar	19
Seat Belt Switch	BK	Near Bottom of Driver's Seat Belt Clasp	20
Shift Interlock	BK	Steering Column, On Shift Cable	N/S
Solar Sensor	RD	Above Glove Box	15
Stop Lamp Switch	GY	Top of Brake Pedal Arm	17
Sunroof Control Module	BK	Rear of Sunroof	N/S
Sunroof Motor	BK	Rear of Sun Roof	N/S
Sunroof Switch	NAT	Center of Headliner, Above Rear View Mirror	19
Switch Pod	BK	Rear of Overdrive Switch	15
Throttle Position Sensor	BK	On Throttle Body	5, 9
Trailer Tow Circuit Breaker	BK	Right Rear Quarter Panel	24
Trailer Tow Left Turn Relay	BK	Right Rear Quarter Panel	24
Trailer Tow Right Turn Relay	BK	Right Rear Quarter Panel	24

Connector Name/Number	Color	Location	Fig.
Trailer Tow Stop Lamp Relay	BK	Right Rear Quarter Panel	24
Transmission Solenoid Assembly	BK	Left Side of Transmission	7, 10
Underhood Lamp	BK	On Underside of Hood	26
Upstream Heated Oxygen Sensor	GY	Right Front of Transmission (5.2L/5.9L) Rear of Power Steering Pump (4.0L)	5,10
Vehicle Speed Control Servo	BK	Right Fender Side Shield	2
Vehicle Speed Control/Horn Switch	NAT	On Steering Column	18
Vehicle Speed Sensor	BK	Rear of Transfer Case	7, 10,14
Water in Fuel Separater	BK	At Fuel Heater / Filter	12
Windshield Washer Pump Motor	BK	Bottom of Windshield Washer Fluid Reservoir	4
Windshield Wiper Motor	BK	Center of Cowl	4

DESCRIPTION AND OPERATION (Continued)

80b3c906

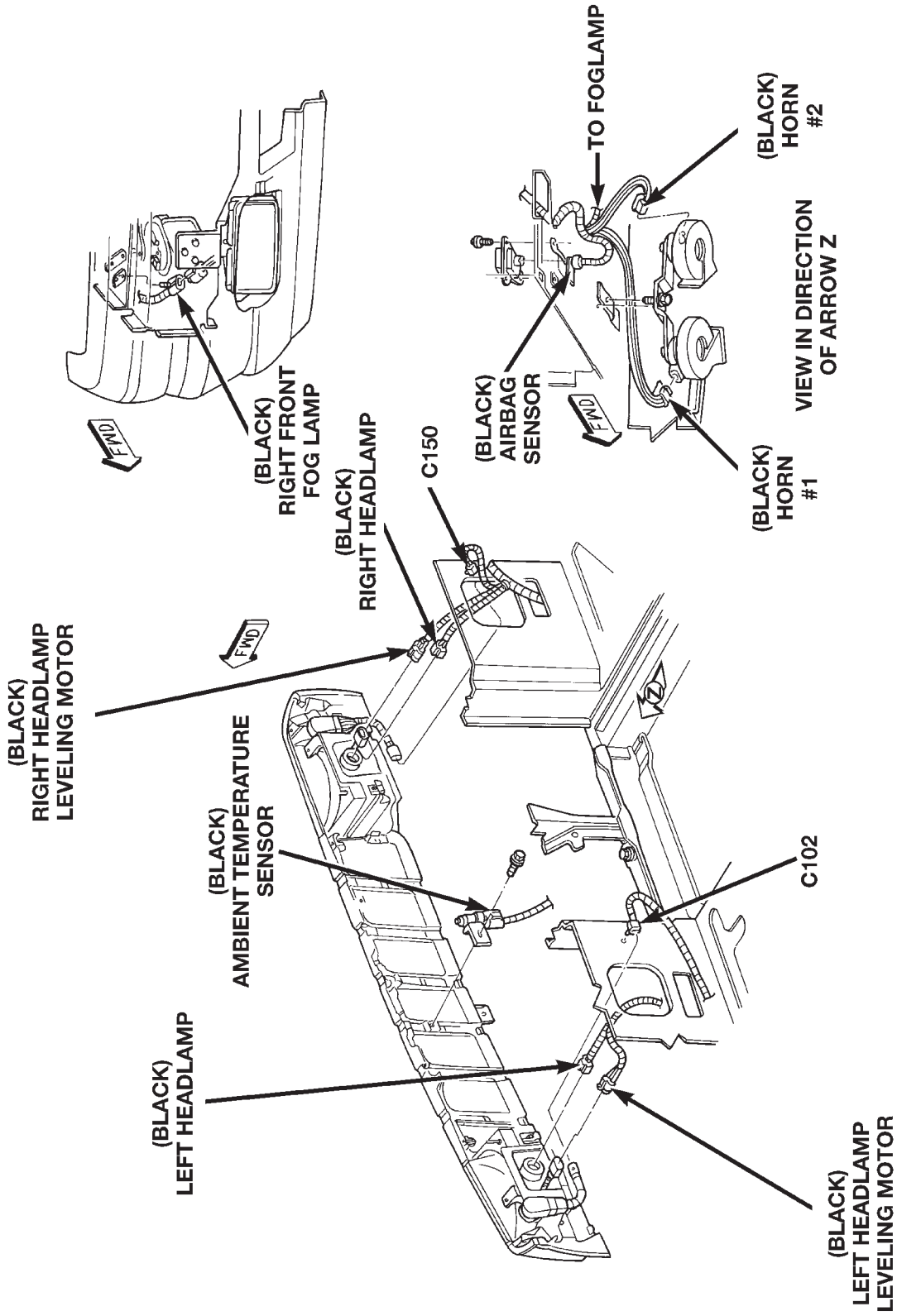


Fig. 1 Front End Lighting—LHD

DESCRIPTION AND OPERATION (Continued)

80b3c907

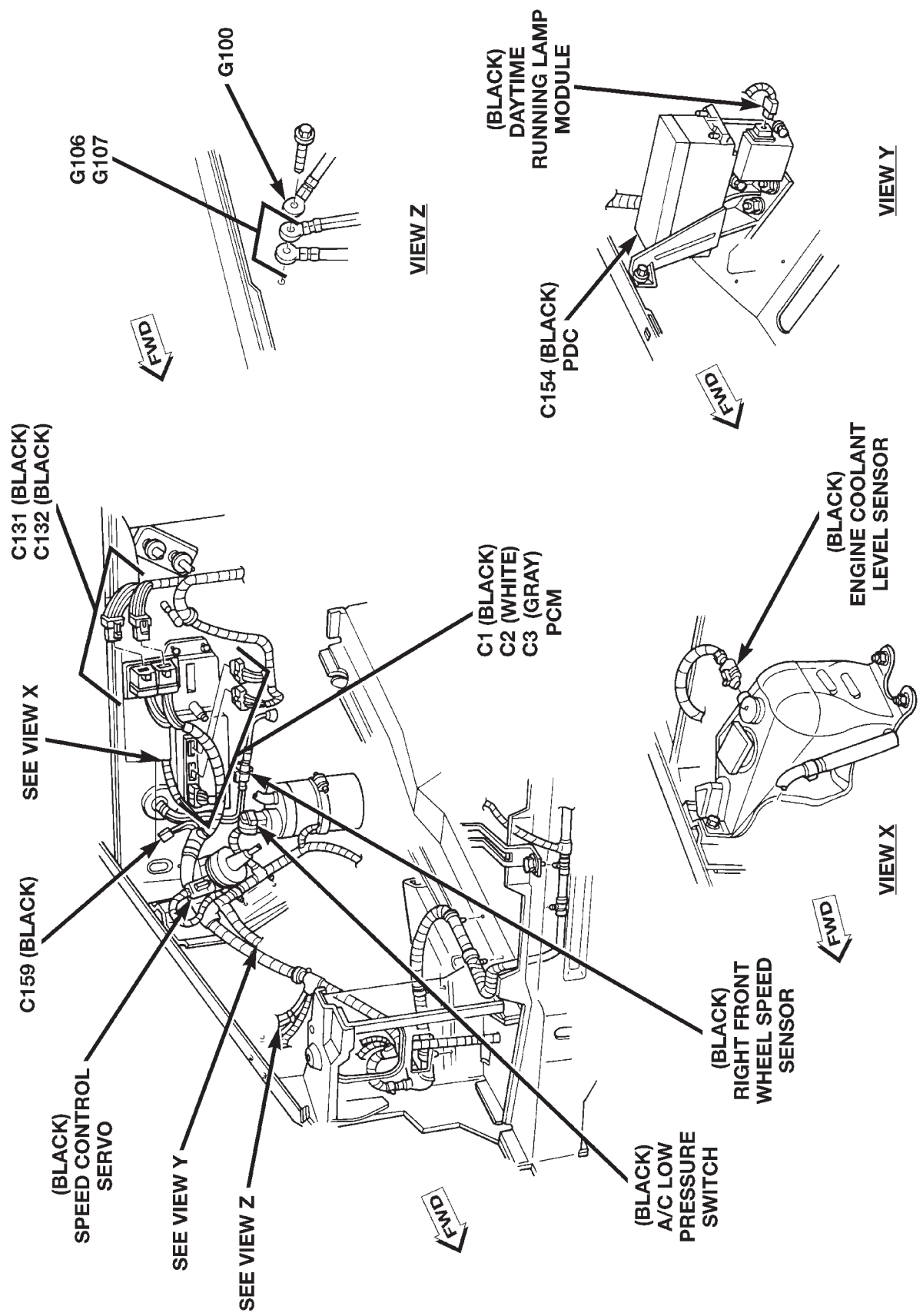


Fig. 2 Engine Compartment — Left Side, LHD

DESCRIPTION AND OPERATION (Continued)

80b3c909

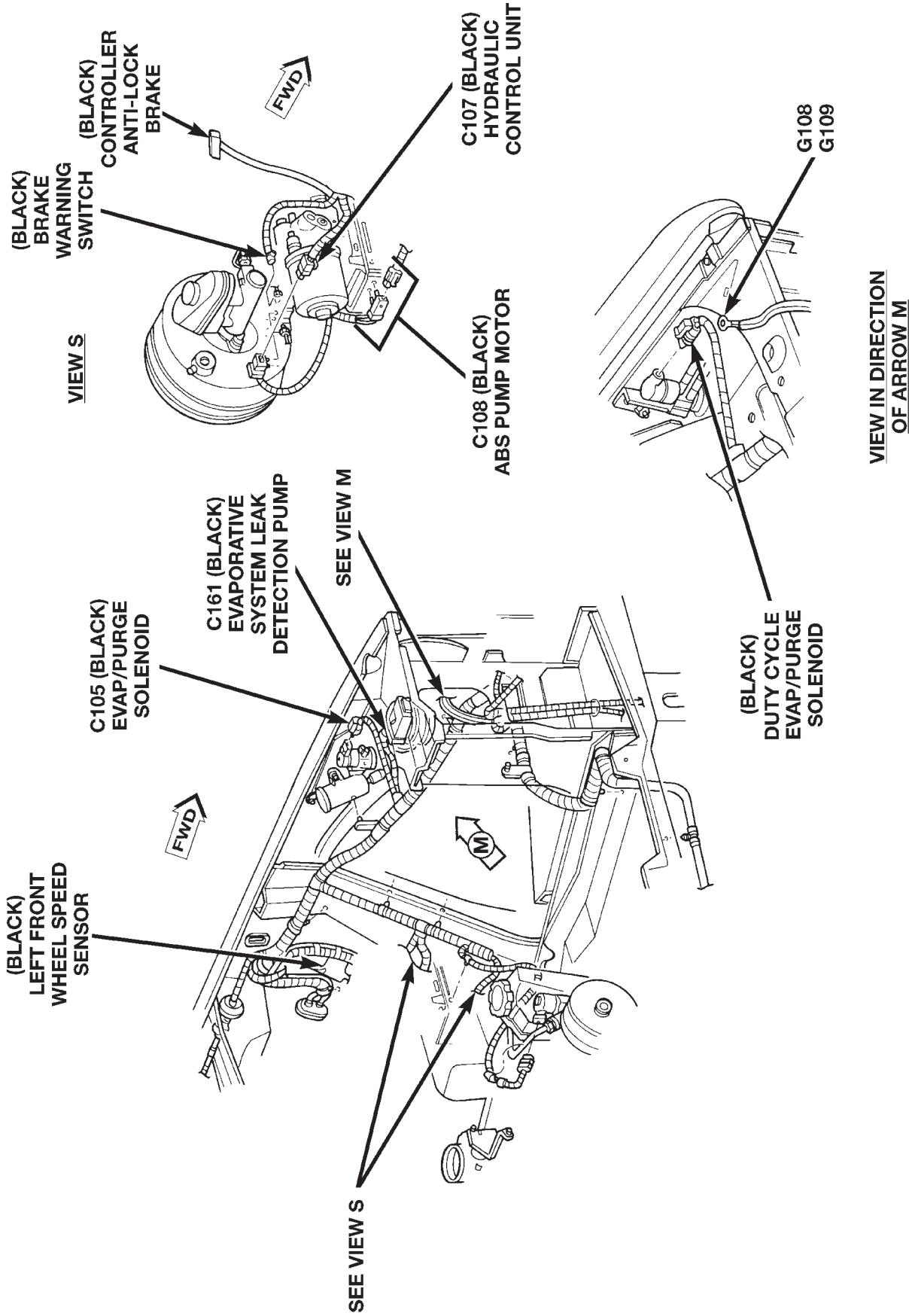


Fig. 3 Engine Compartment—Right Side, LHD

DESCRIPTION AND OPERATION (Continued)

80b3c90a

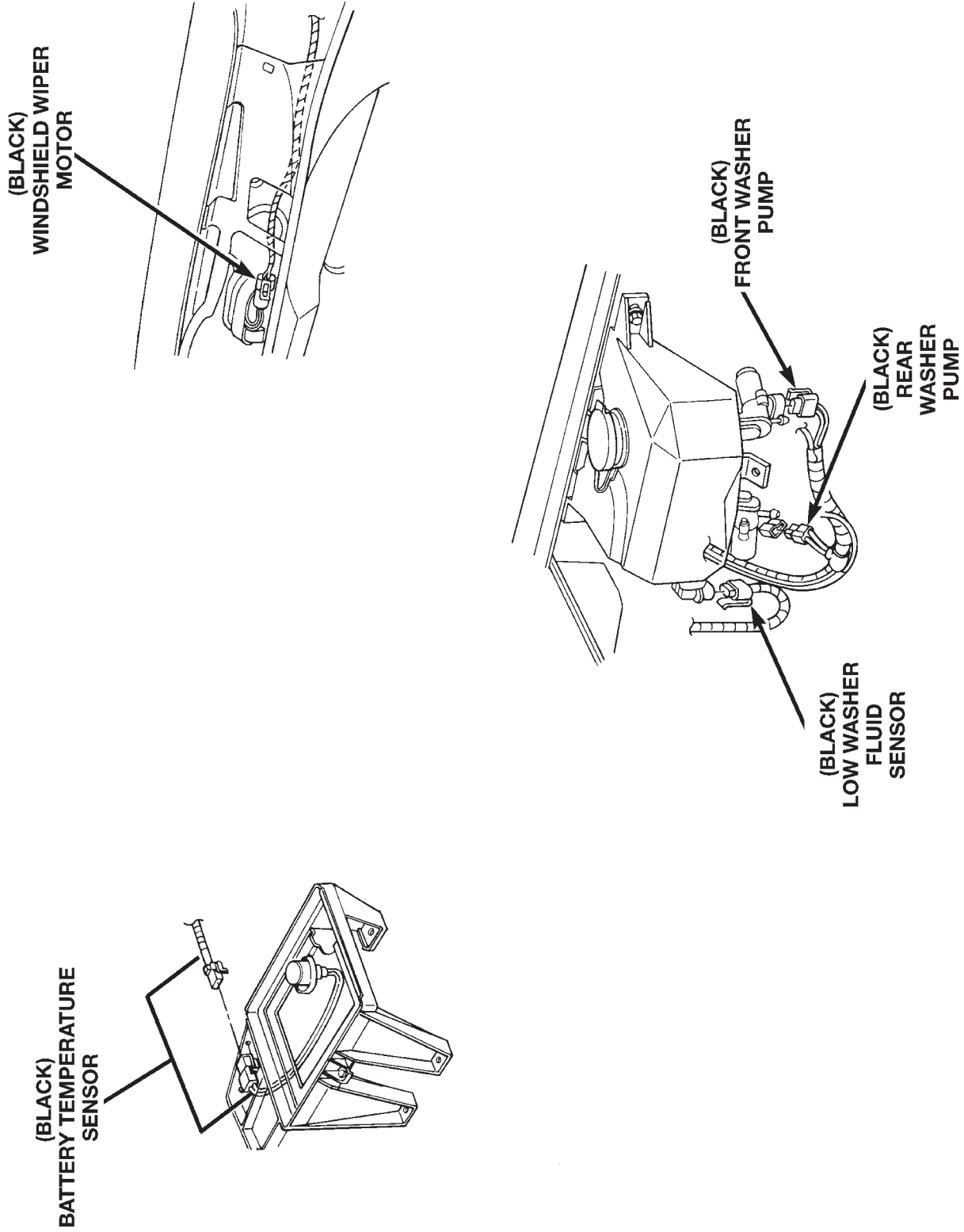
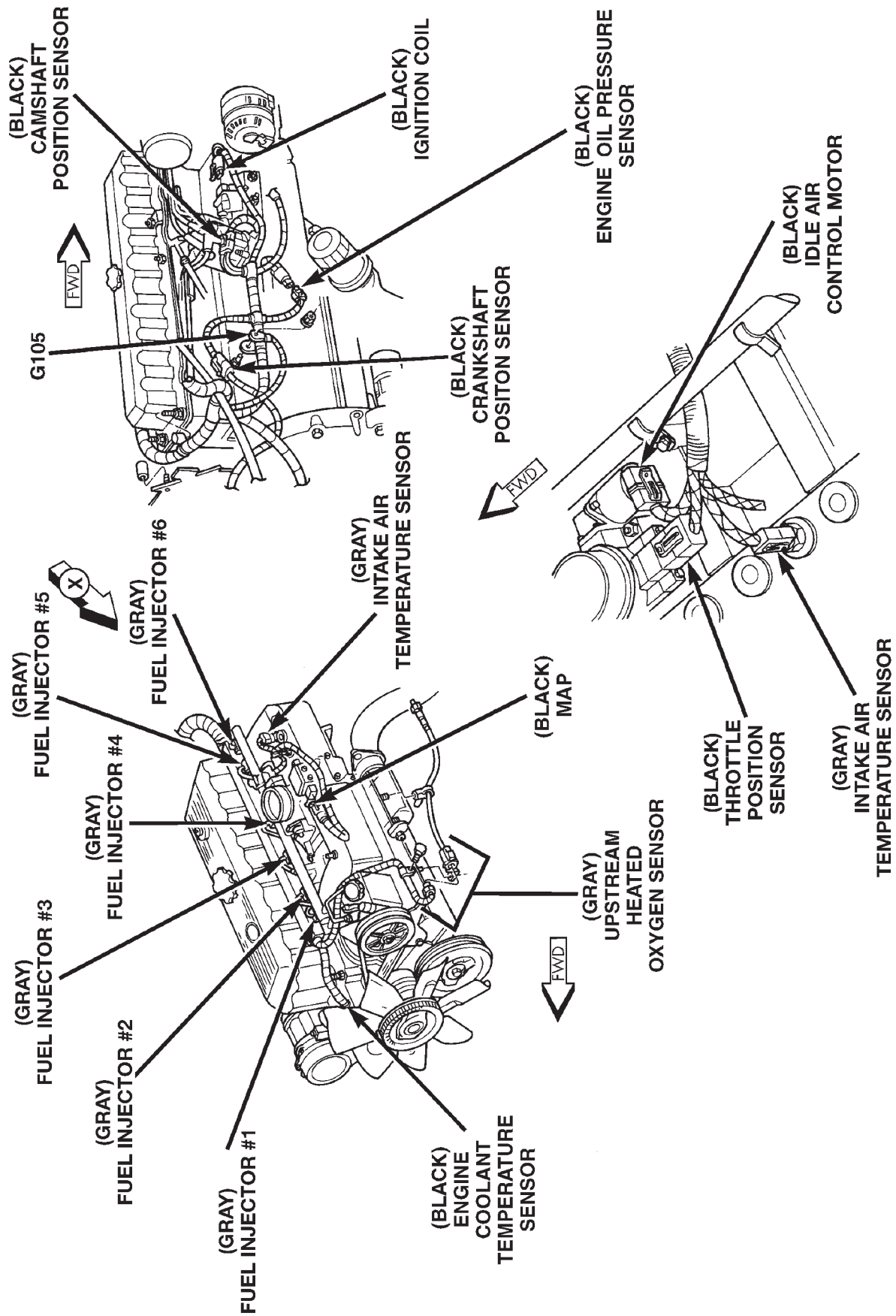


Fig. 4 Engine Compartment Connectors — LHD

DESCRIPTION AND OPERATION (Continued)



80b3c90b

Fig. 5 Engine Connectors—4.0L Engine, LHD

DESCRIPTION AND OPERATION (Continued)

80b3c90c

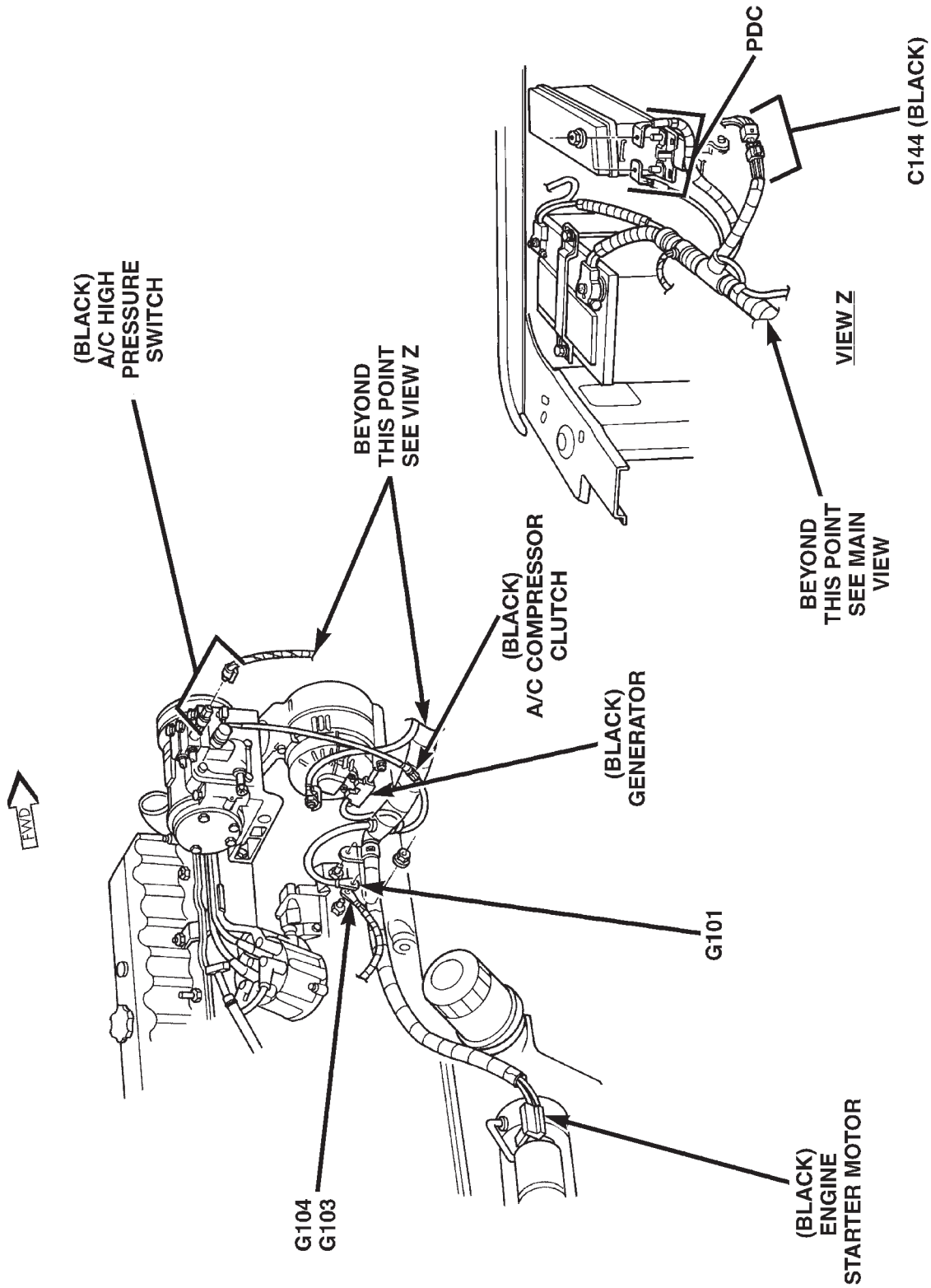
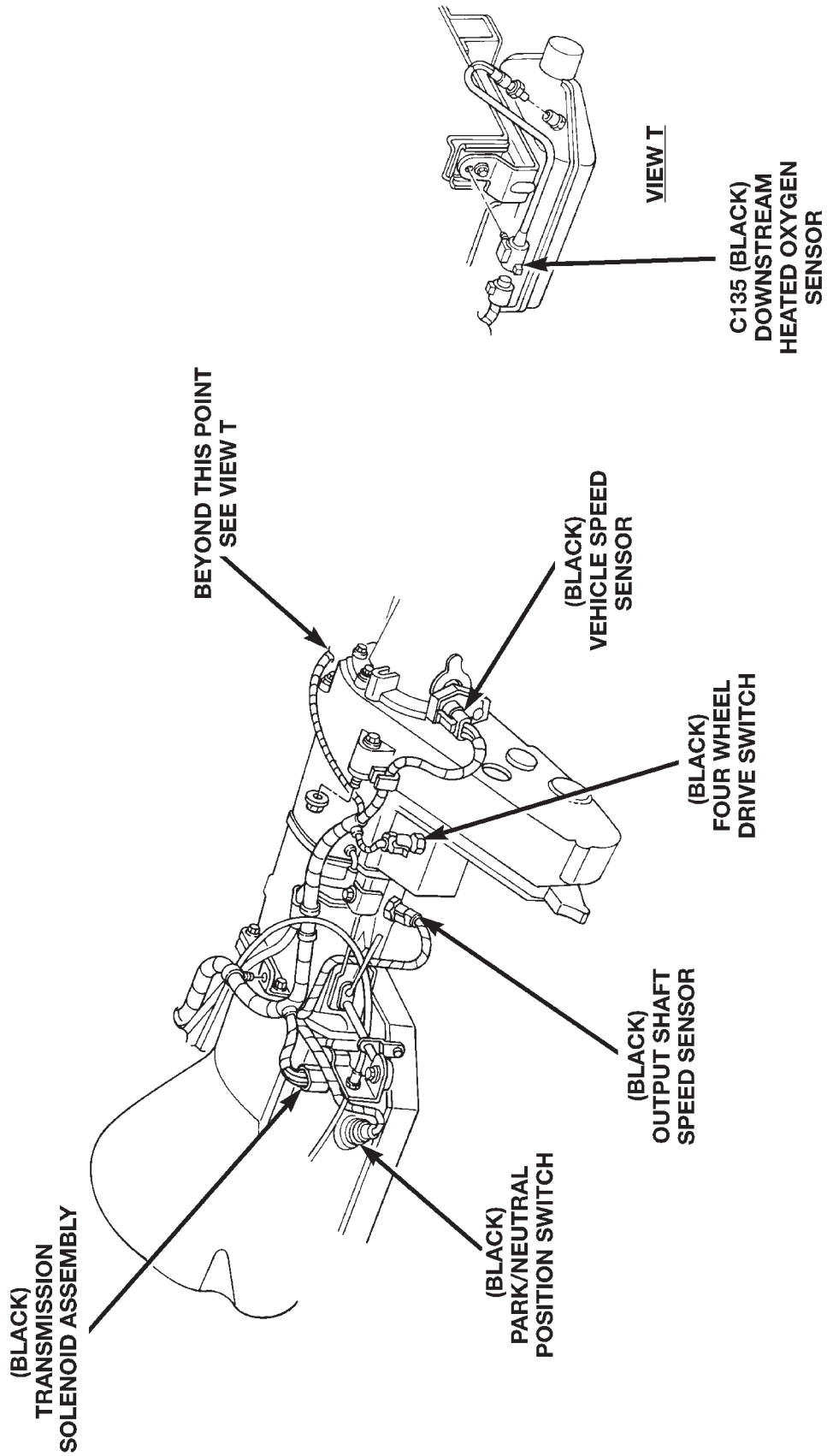


Fig. 6 Charging System Connectors—4.0L Engine, LHD

DESCRIPTION AND OPERATION (Continued)



80a8376c

Fig. 7 Transmission Connectors—4.0L Engine, LHD

DESCRIPTION AND OPERATION (Continued)

80b3c90e

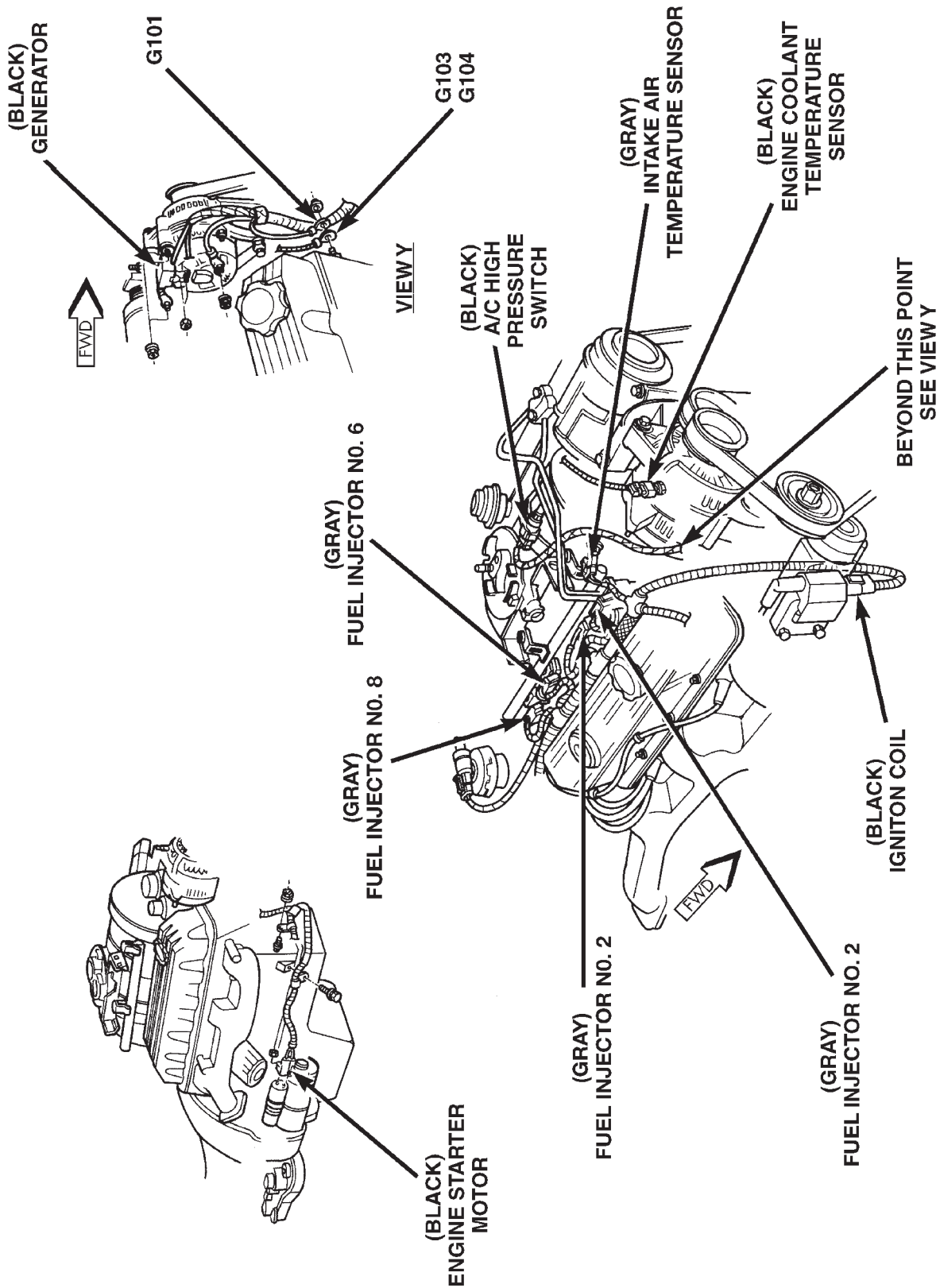
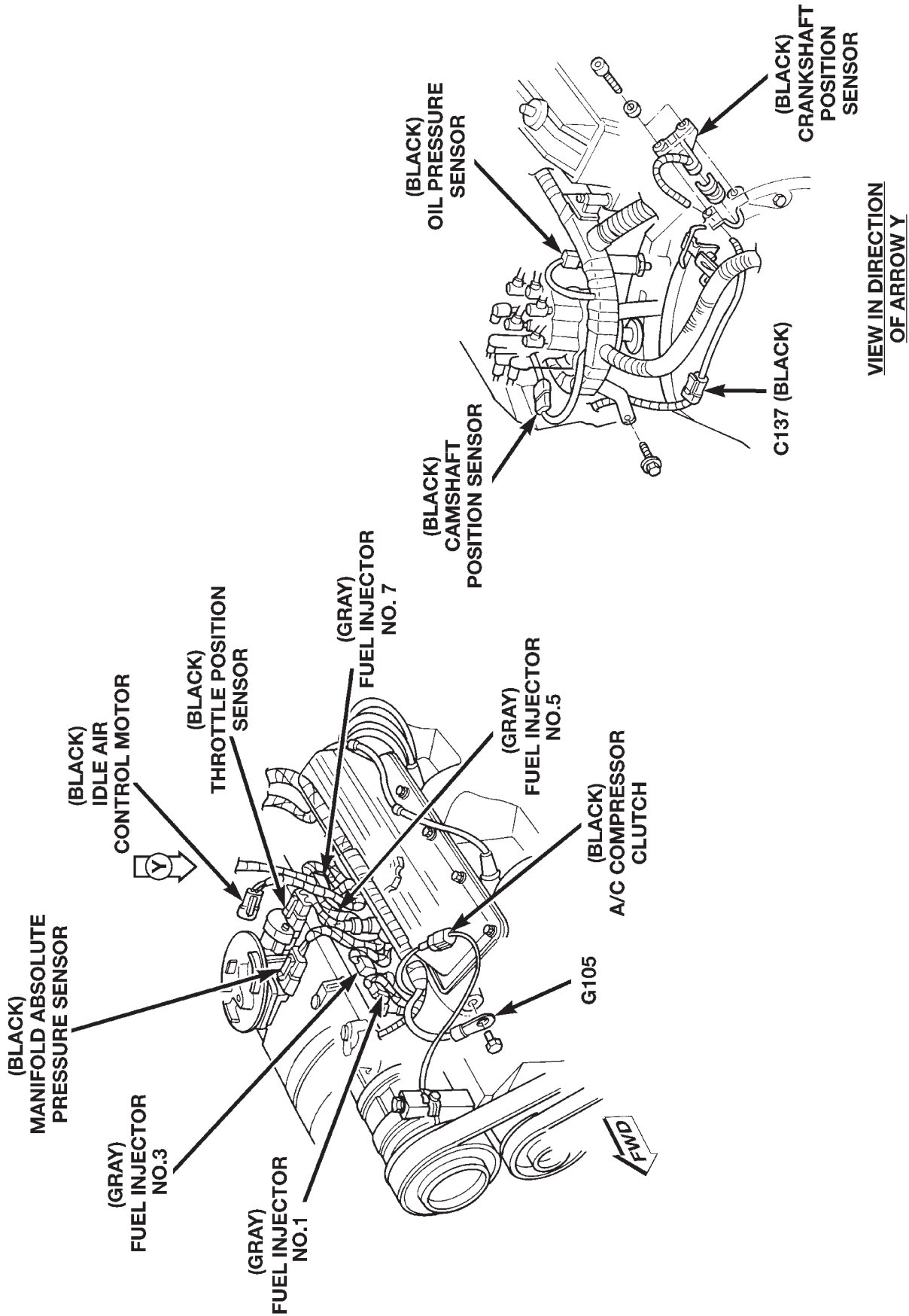


Fig. 8 Engine Connectors—5.2L Engine, LHD

DESCRIPTION AND OPERATION (Continued)



80b3c90f

Fig. 9 Engine Connectors — 5.2L Engine, LHD

DESCRIPTION AND OPERATION (Continued)

80b3c910

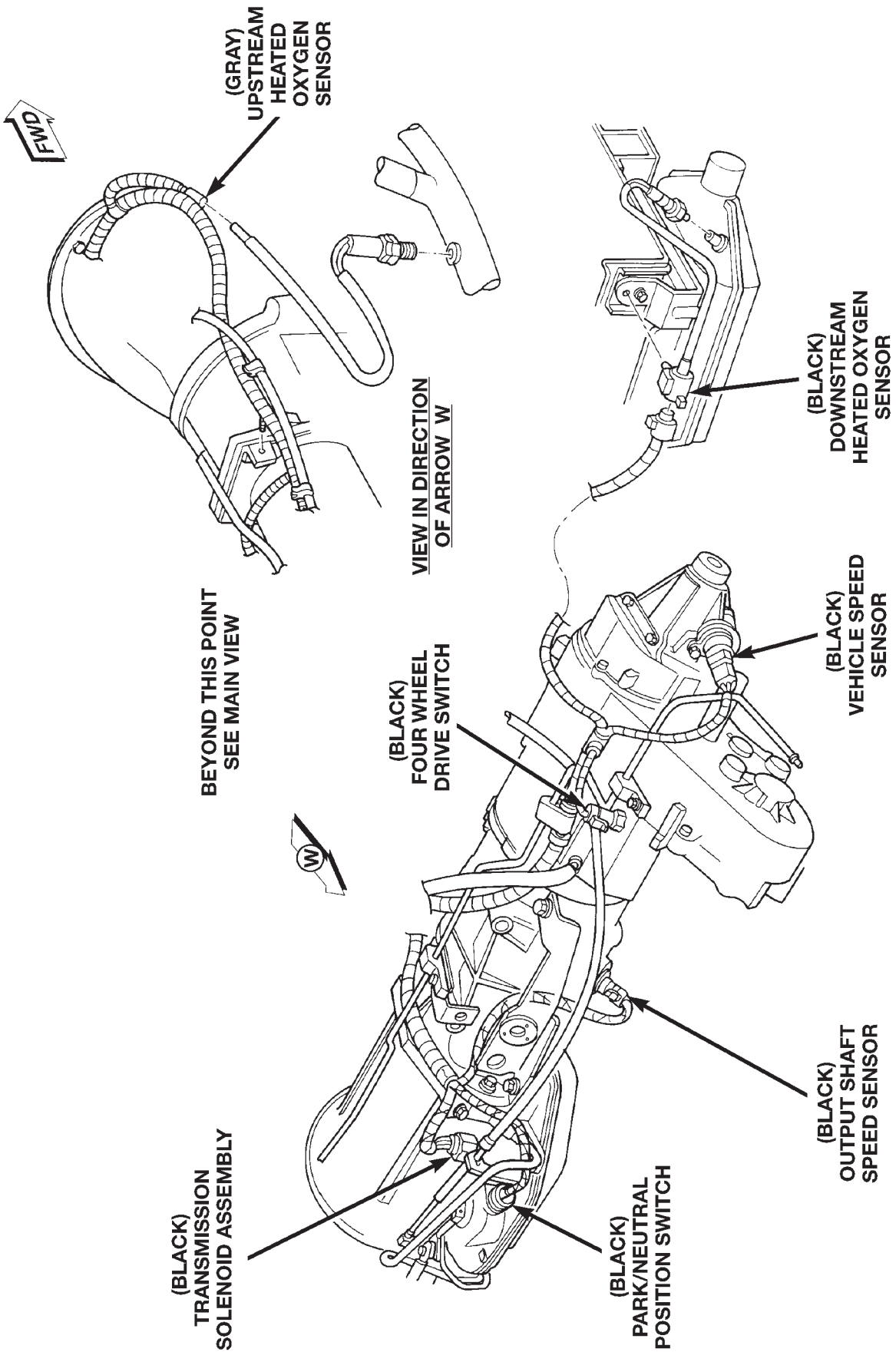


Fig. 10 Transmission Connectors—5.2L, LHD

DESCRIPTION AND OPERATION (Continued)

8063c911

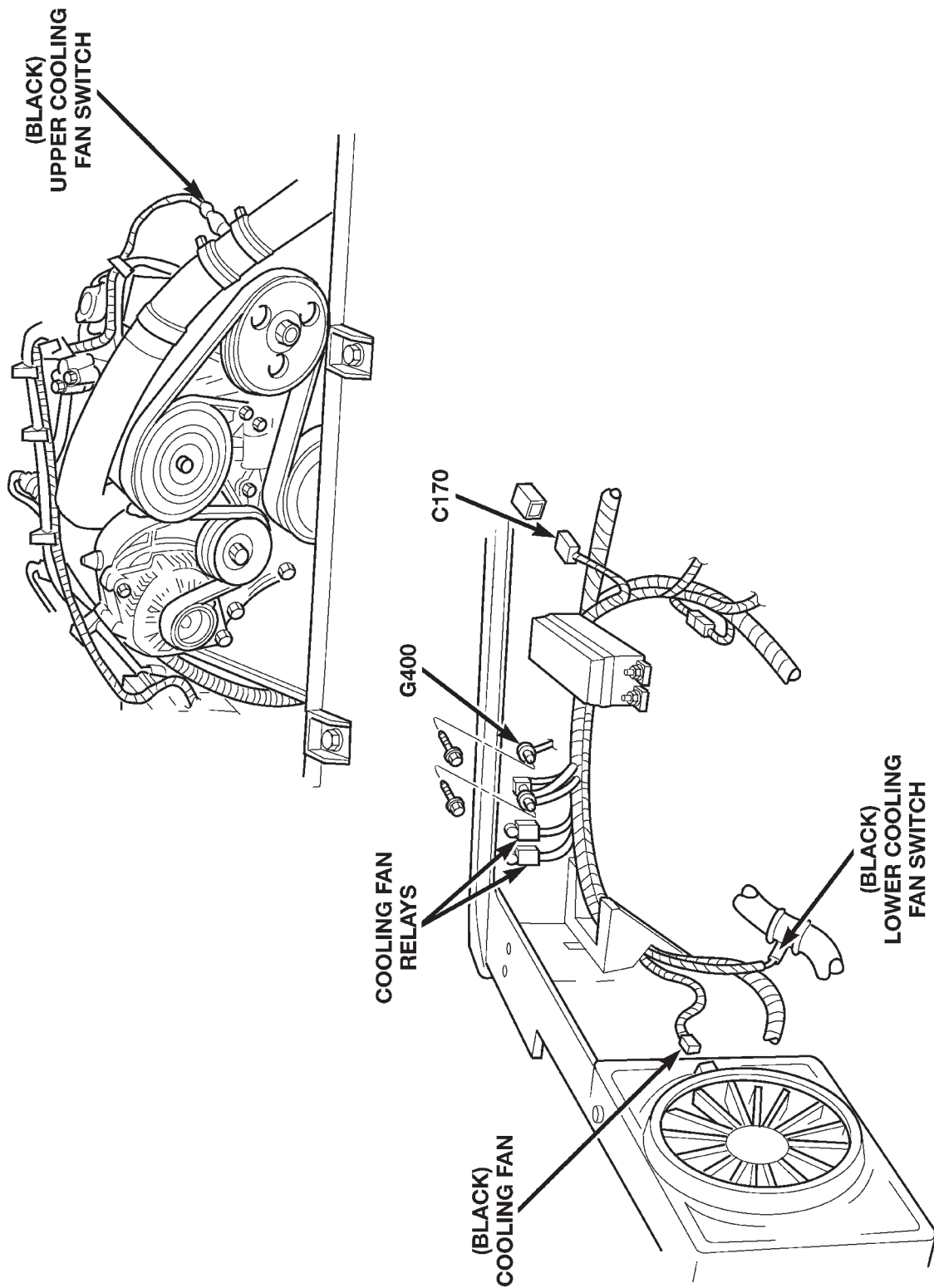


Fig. 11 Cooling Fan—5.2L/5.9L, LHD

DESCRIPTION AND OPERATION (Continued)

80b3c912

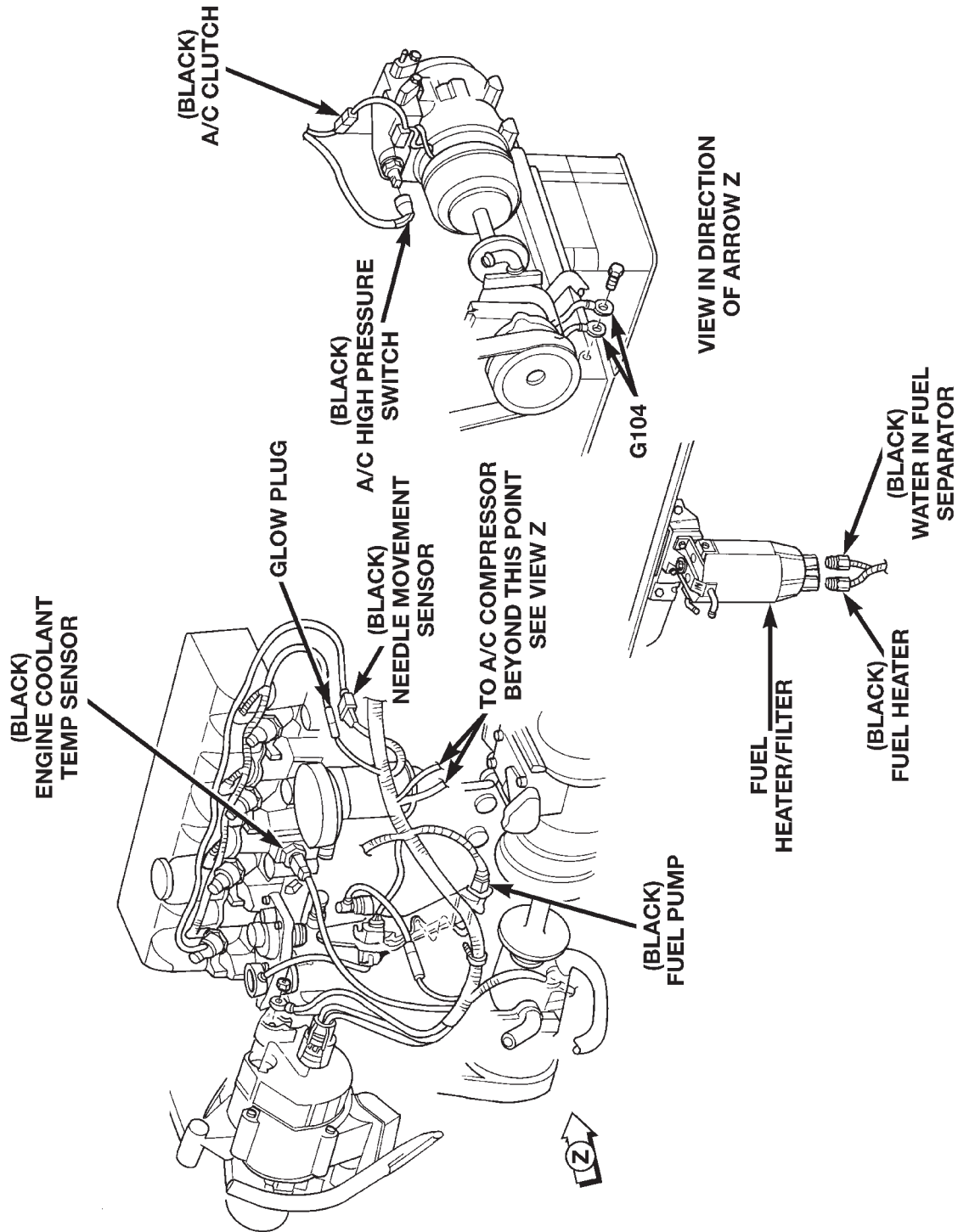


Fig. 12 Engine Connectors— Diesel Engine, LHD

DESCRIPTION AND OPERATION (Continued)

8053c913

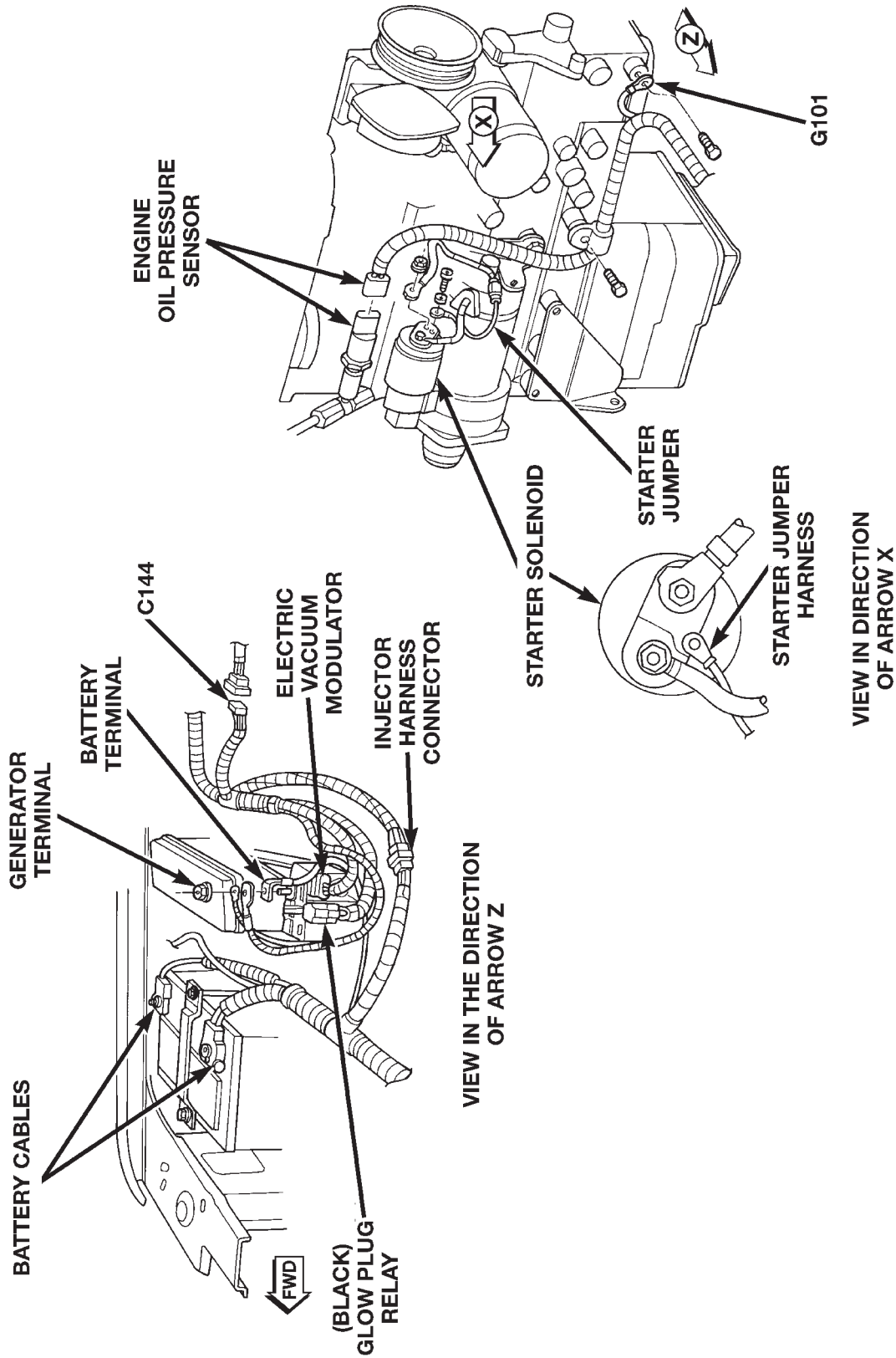


Fig. 13 Battery and Starter Motor Connectors—Diesel Engine, LHD

DESCRIPTION AND OPERATION (Continued)

8053c914

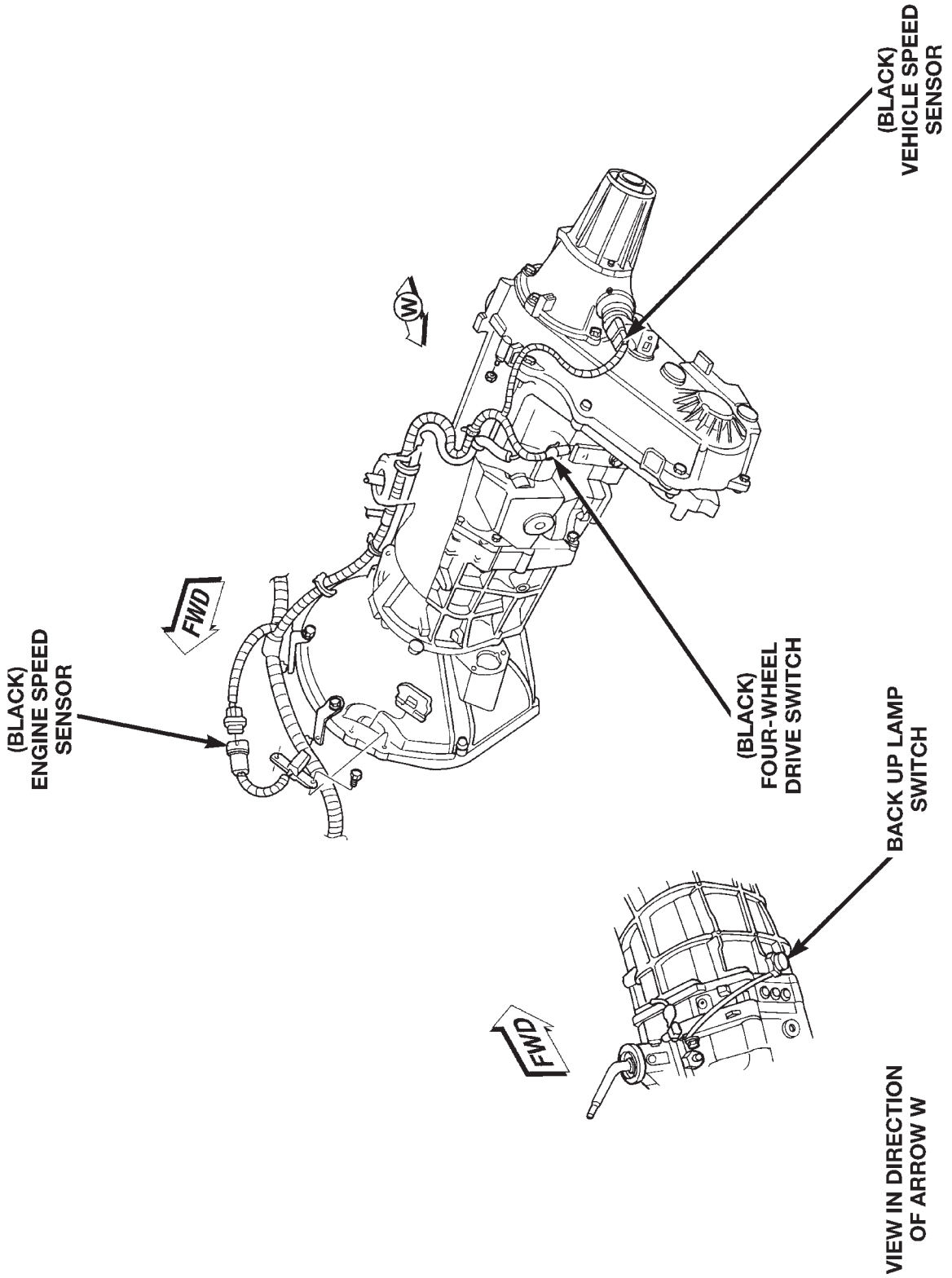
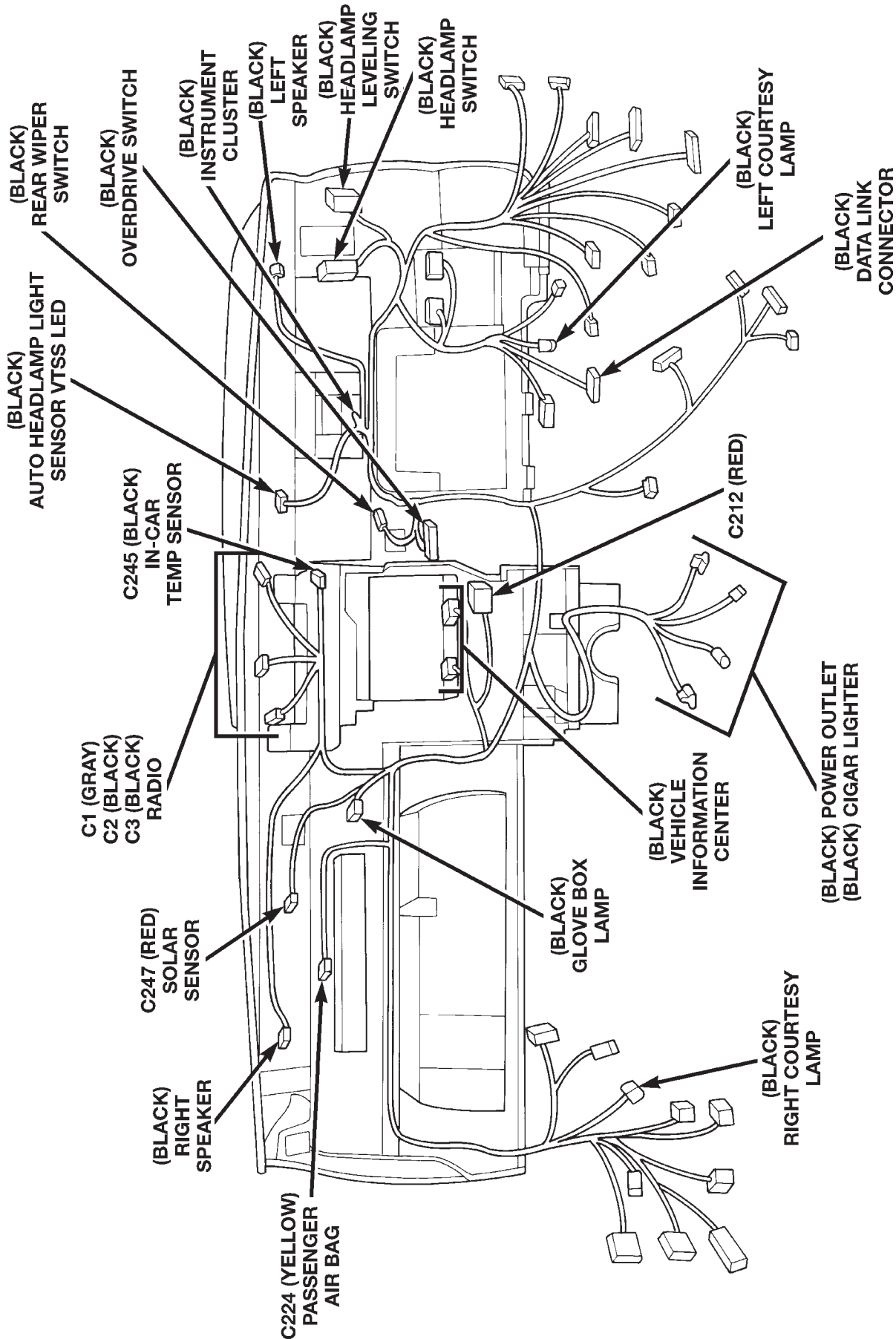


Fig. 14 Transmission Connectors—Diesel Engine, LHD

DESCRIPTION AND OPERATION (Continued)



80b3c915

Fig. 15 Instrument Panel Connectors—LHD

DESCRIPTION AND OPERATION (Continued)

80b3c916

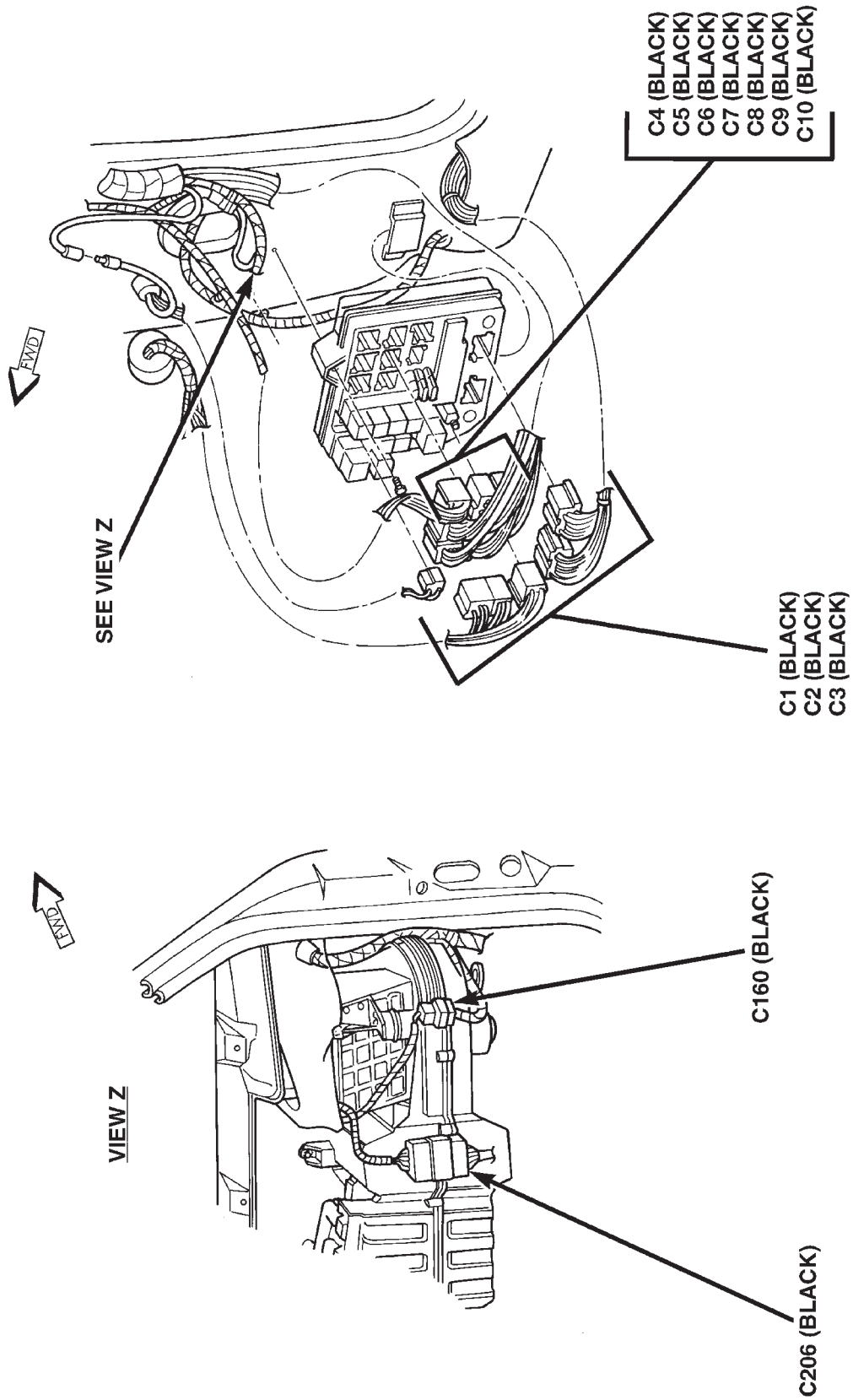


Fig. 16 Junction Block and HVAC Unit Connectors—LHD

DESCRIPTION AND OPERATION (Continued)

80b3c917

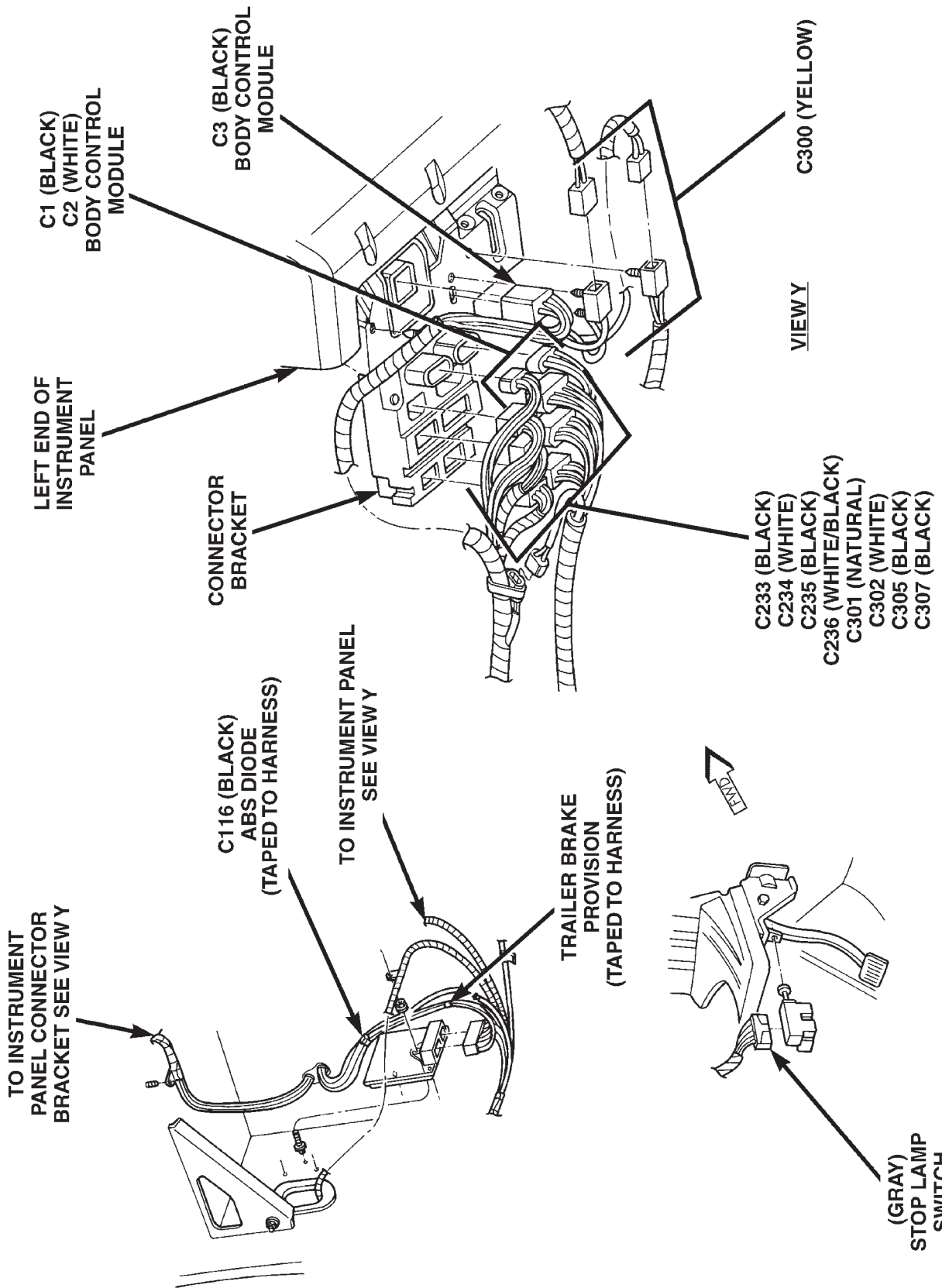


Fig. 17 Instrument Panel Connectors—Left Side, LHD

DESCRIPTION AND OPERATION (Continued)

80b3c918

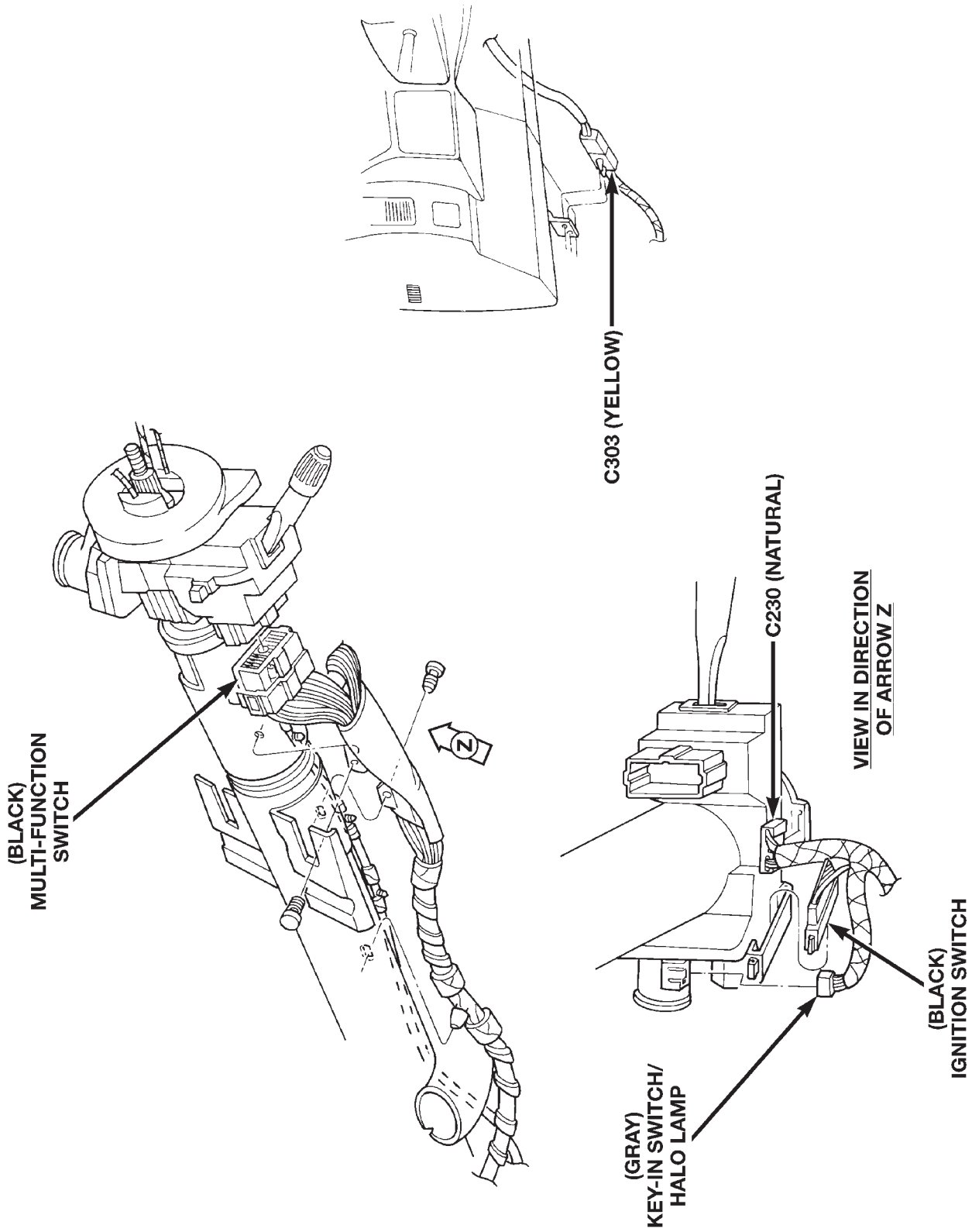


Fig. 18 Steering Column Connectors—LHD

DESCRIPTION AND OPERATION (Continued)

80b3c919

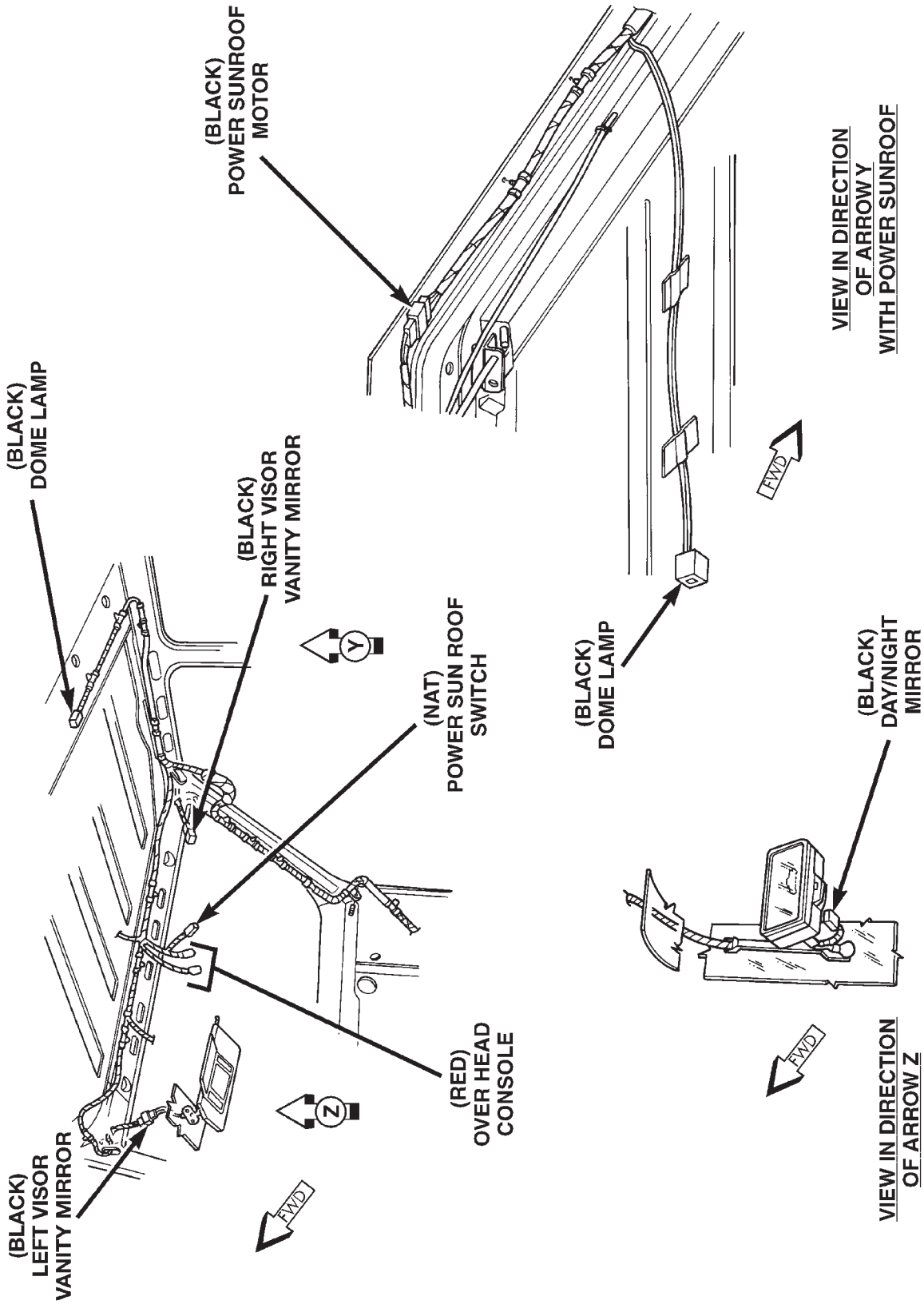


Fig. 19 Roof Connectors—LHD

DESCRIPTION AND OPERATION (Continued)

80b3c91a

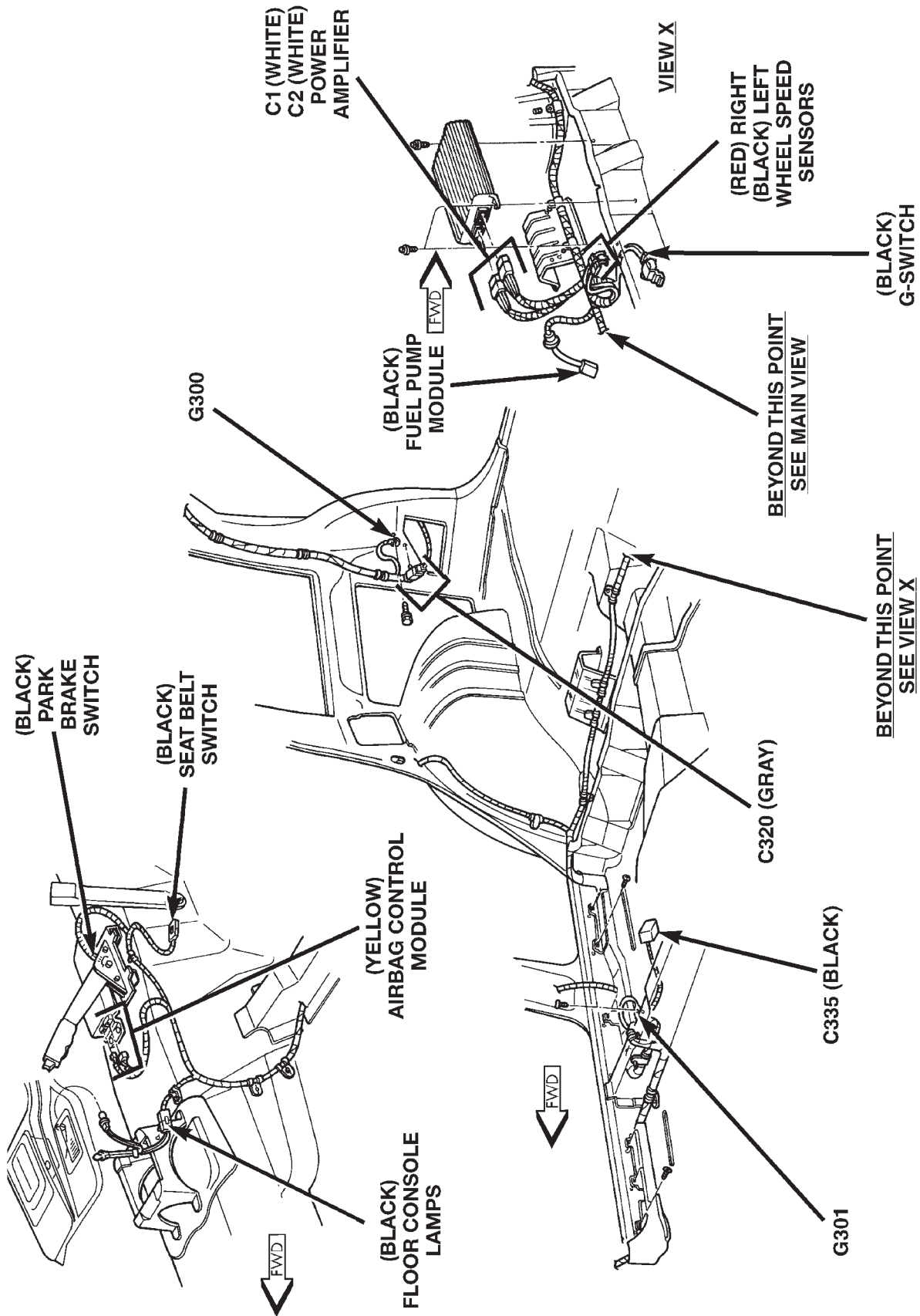
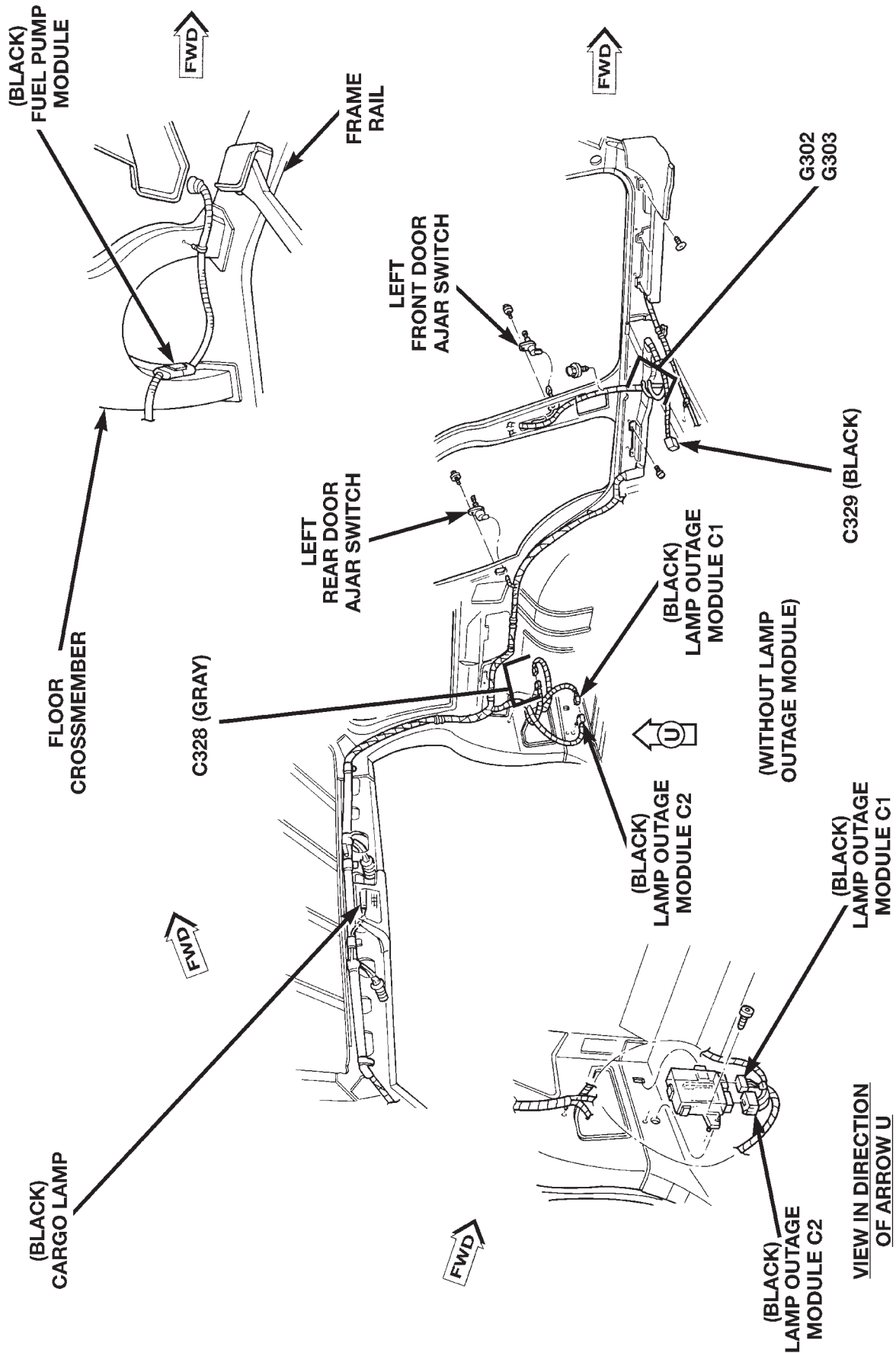


Fig. 20 Body Connectors — Right Side, LHD

DESCRIPTION AND OPERATION (Continued)



80b3c91b

Fig. 21 Body Connectors—Left Side, LHD

DESCRIPTION AND OPERATION (Continued)

80b3c91c

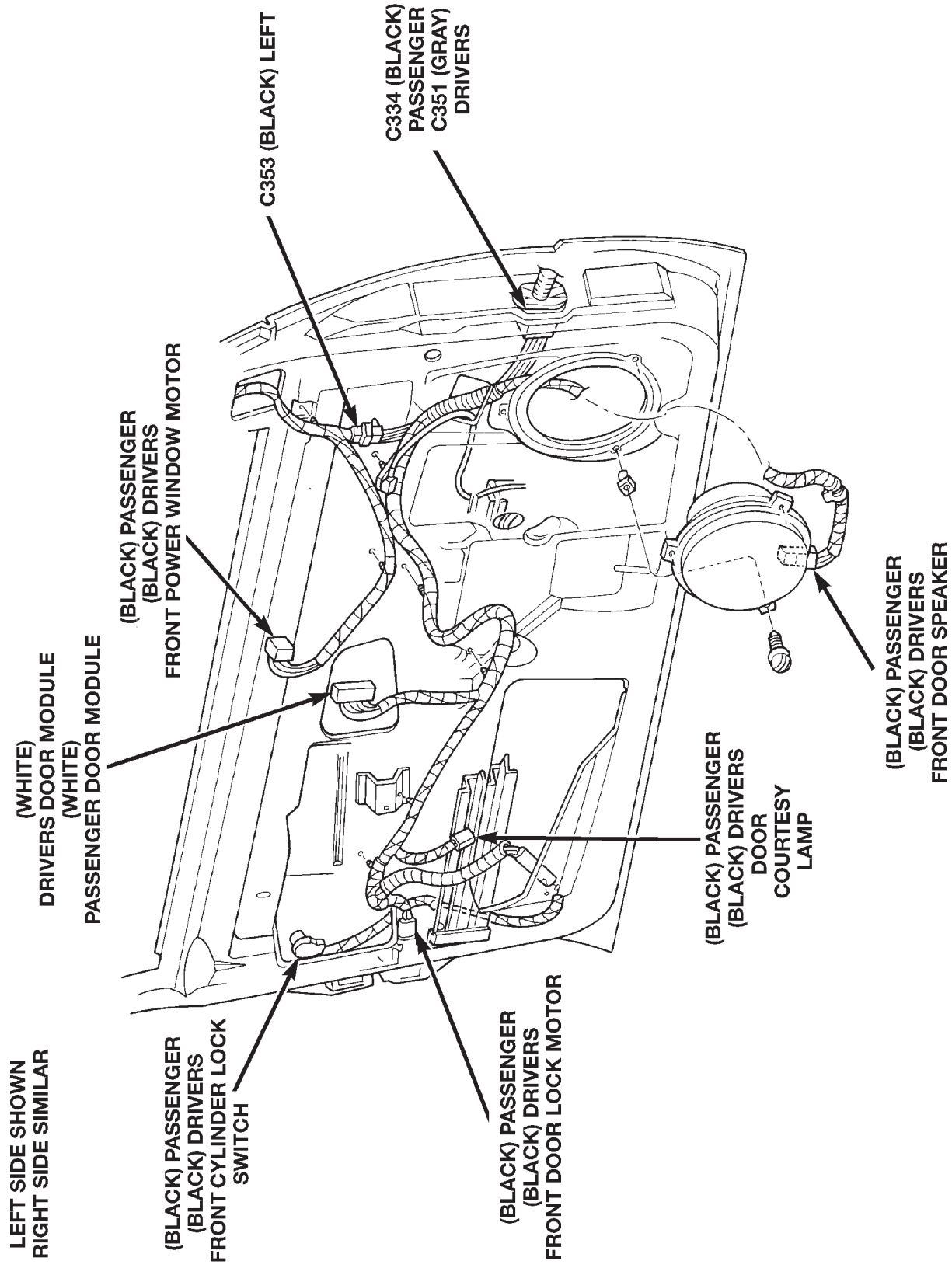
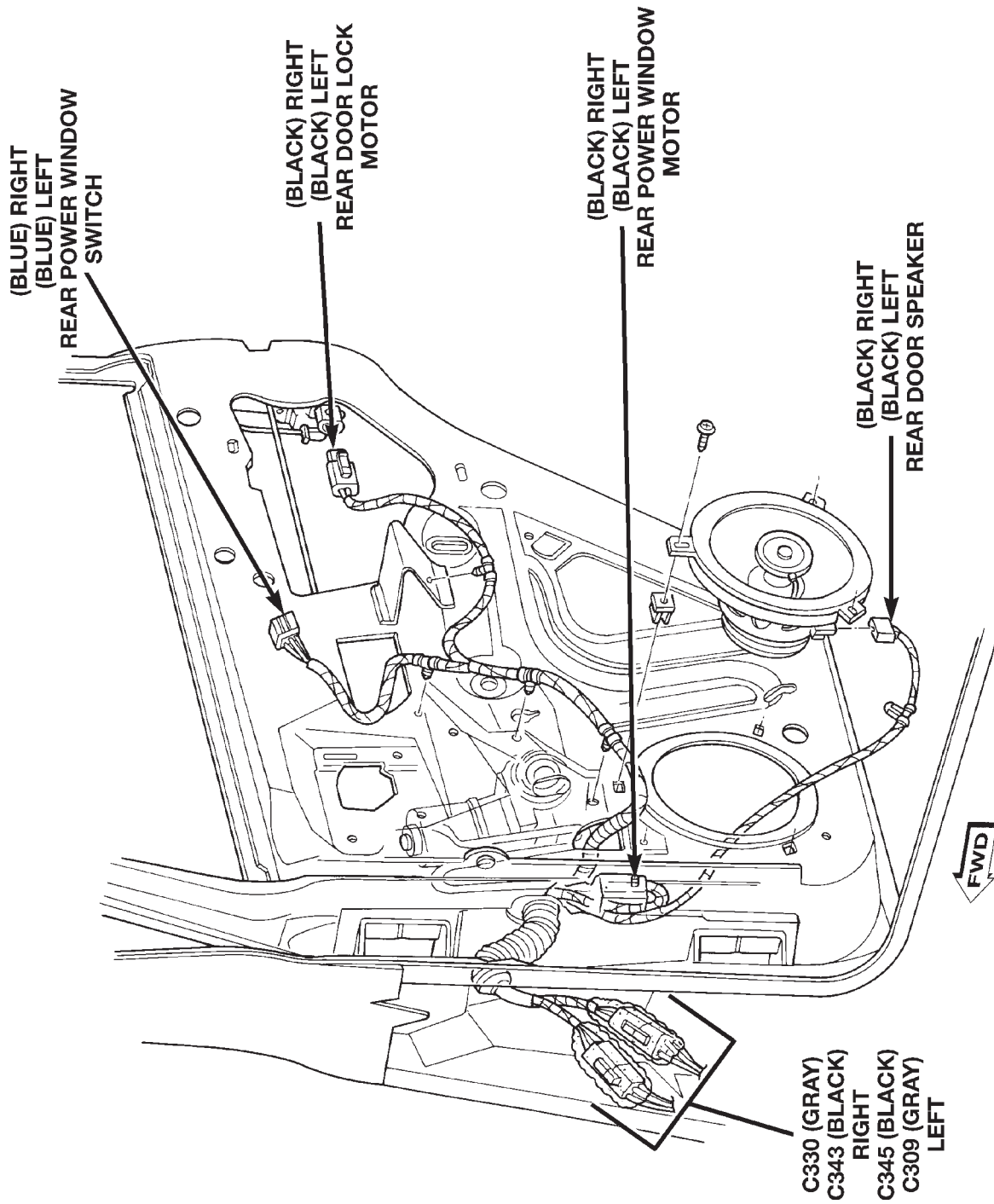


Fig. 22 Front Door Connectors—LHD

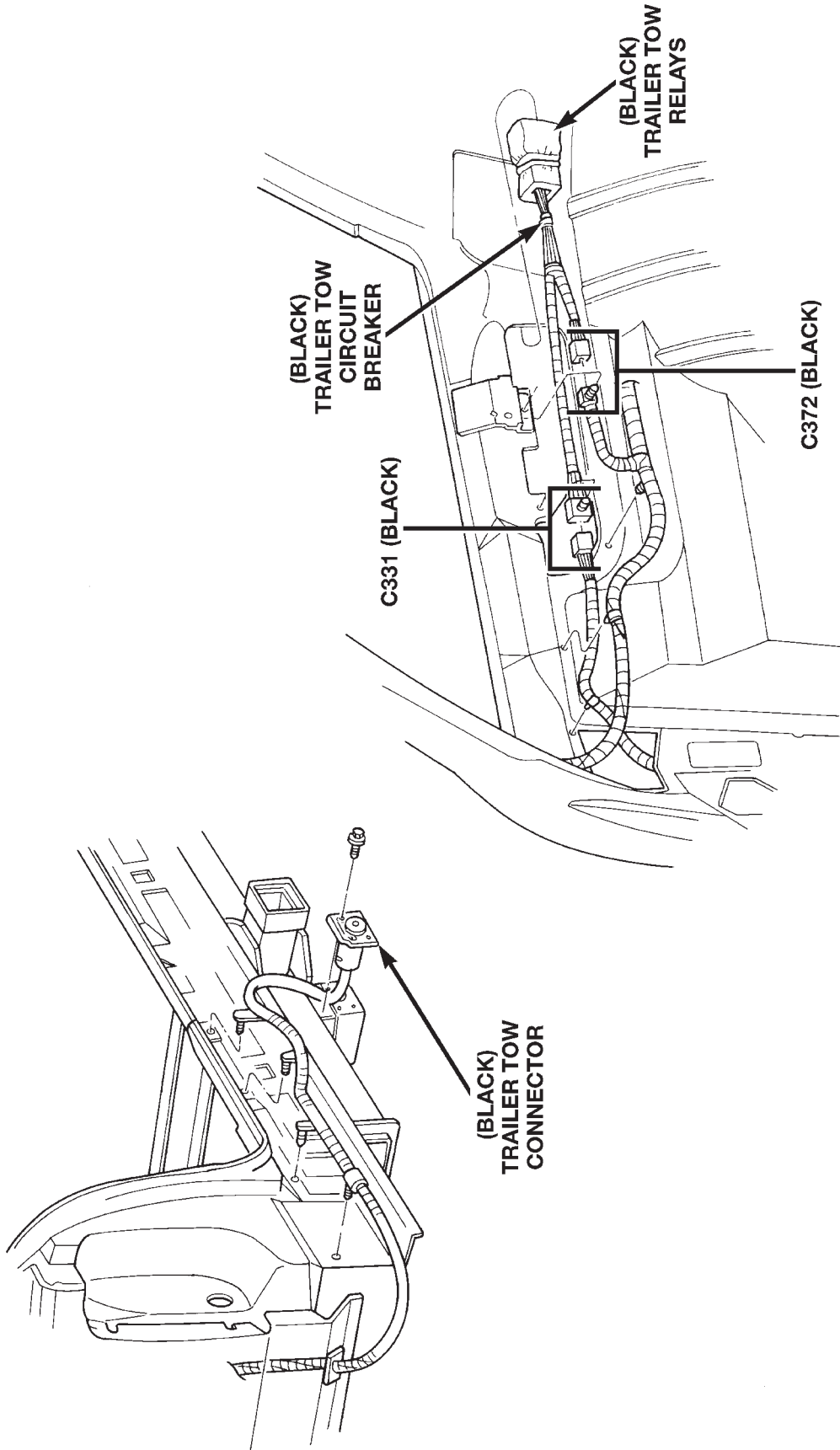
DESCRIPTION AND OPERATION (Continued)



80b3c91e

Fig. 23 Rear Door Connectors — LHD

DESCRIPTION AND OPERATION (Continued)



80b3c91f

Fig. 24 Factory Trailer Tow—LHD

DESCRIPTION AND OPERATION (Continued)

80b3c920

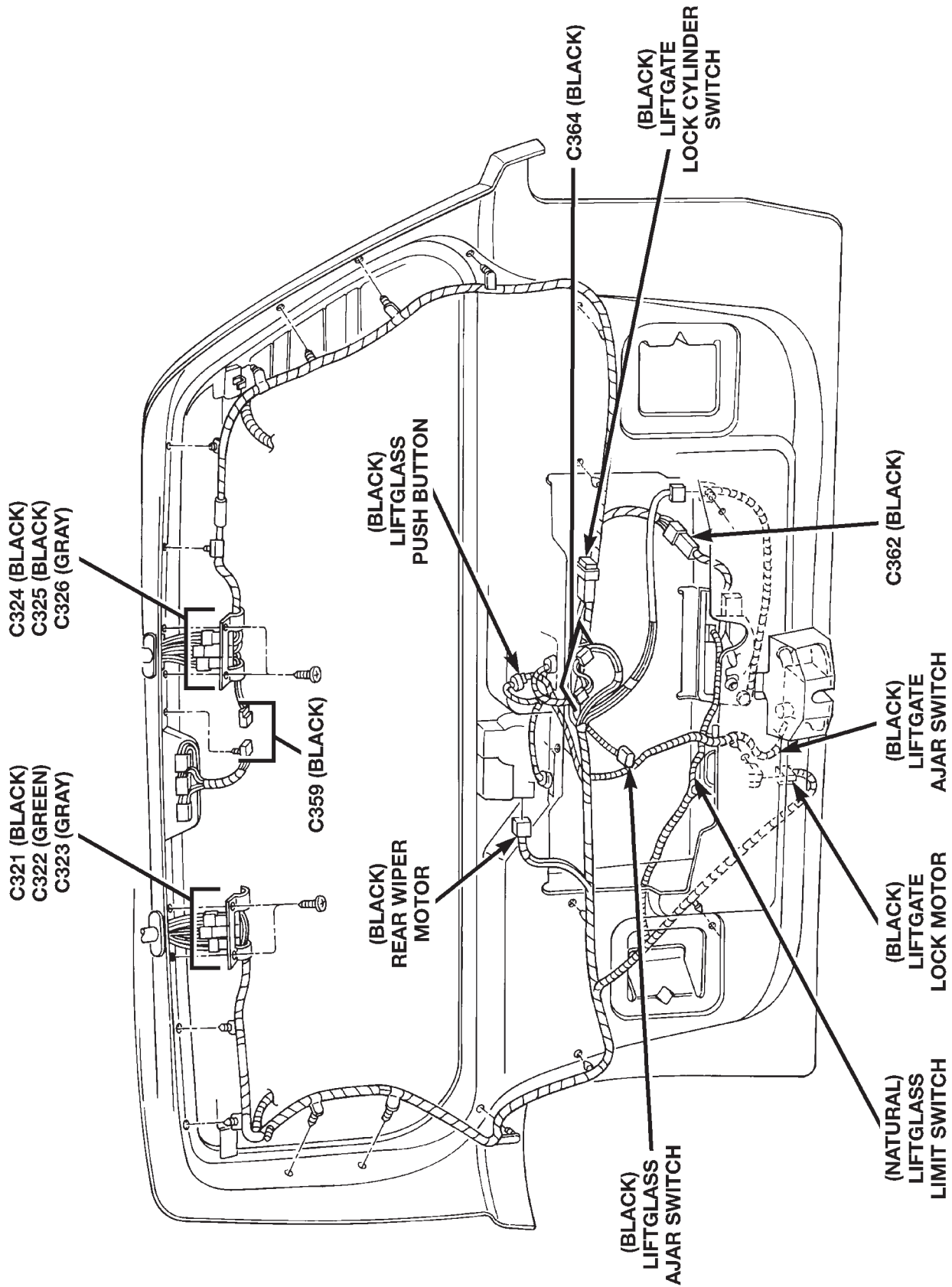


Fig. 25 Liftgate Connectors — LHD

DESCRIPTION AND OPERATION (Continued)

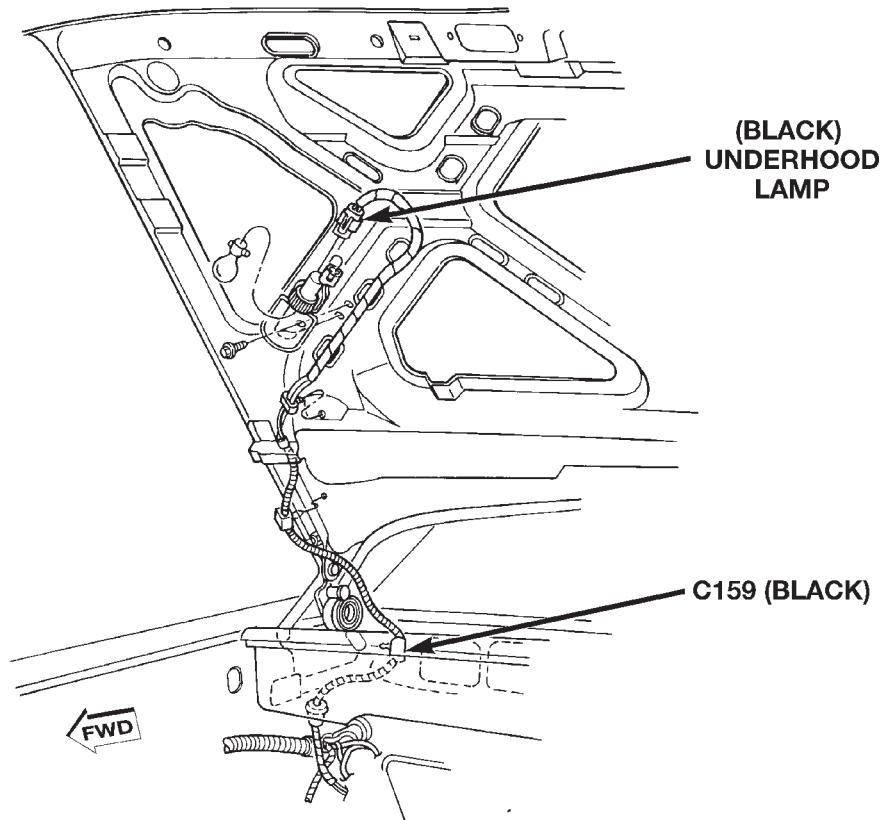


Fig. 26 Underhood Lamp—LHD

80b2b70a

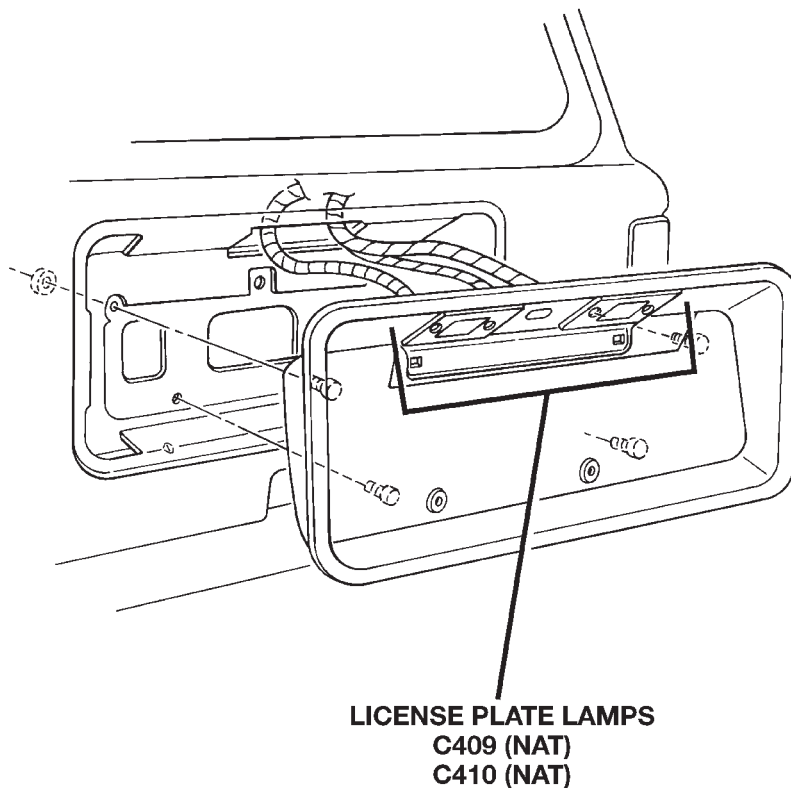


Fig. 27 License Plate Lamps—LHD

80b2b708

DESCRIPTION AND OPERATION (Continued)**CONNECTOR/GROUND LOCATIONS (RHD)**

For items that are not shown in this section N/S is placed in the Fig. column.

Connector Name/Number	Color	Location	Fig.
A/C Heater Control C1	BK	Rear of Switch	N/S
A/C Heater Control C2	BK	Rear of Switch	N/S
A/C High Pressure Switch	BK	Near A/C Compressor	5
A/C Low Pressure Switch	BK	Right Rear Corner of Engine Compartment (4.0L) Near T/O for Left Fog Lamp (Diesel) Not Shown	2
After Market Trailer Tow Connector	BK	Left Rear Quarter Panel	N/S
Airbag Control Module	BK	Below Center Floor Console, Near Park Brake	15
Ambient Temperature Sensor	BK	On Radiator Center Support	1
Ash Receiver Lamp		At Lamp	11
Auto Headlamp Light Sensor/ VTSS LED	BK	Top of Instrument Panel, Left Side	11
Automatic Temperature Control Module	BK	Left Side of HVAC Housing	12
Battery Temperature Sensor	BK	Below Battery Tray	3
Blend Air Door Motor	BK	On Bottom of HVAC Unit	N/S
Blend Air Actuator	BK	On Bottom of HVAC Unit	N/S
Blower Motor	NAT	Right Side of HVAC	N/S

Connector Name/Number	Color	Location	Fig.
Blower Motor Resistor Block	BK	Right Side of HVAC	N/S
Blower Motor Switch	BK	On HVAC Unit	N/S
Blower Power Module	BK	On HVAC Unit	N/S
Body Control Module C1	BK	Lower Right of Instrument Panel	N/S
Body Control Module C2	WT	Lower Right of Instrument Panel	N/S
Body Control Module C3	BK	Lower Left of Instrument Panel	N/S
Brake Pressure Switch	BK	Near Brake Master Cylinder	3
C102	BK	Rear of Left HeadLamp	1
C131	BK	Right Rear Corner of Engine Compartment, Near PCM	2
C132	BK	Right Rear Corner of Engine Compartment, Near PCM	2
C144	BK	Near PDC	9
C150	BK	Rear of Right HeadLamp	1
C160	BK	Left Corner of Instrument Panel	N/S
C170		Front Right of Engine Compartment	N/S
C171		Front Right of Engine Compartment	N/S
C182		Near G-Switch T/O	N/S

DESCRIPTION AND OPERATION (Continued)

Connector Name/Number	Color	Location	Fig.
C206	BK	On Front of HVAC Unit	N/S
C212	RD	Center of Instrument Panel	N/S
C231	BK	Right End of Instrument Panel	N/S
C233	BK	Lower Left Instrument Panel, In Connector Bracket	12
C234	WT	Lower Left Instrument Panel, In Connector Bracket	12
C235	BK	Lower Left Instrument Panel, In Connector Bracket	12
C236	WT	Lower Left Instrument Panel, In Connector Bracket	12
C300	YL	Lower Instrument Panel	11
C301	NAT	Lower Instrument Panel, In Connector Bracket	11
C302	WT	Lower Instrument Panel, In Connector Bracket	11
C304	GY	Near Blower Motor T/O	N/S
C305	BK	Lower Instrument Panel, In Connector Bracket	N/S

Connector Name/Number	Color	Location	Fig.
C307	BK	Lower Instrument Panel	11
C309	GY	In Left Rear Door	18
C316	BK	Left Rear Quarter	16
C320	GY	Right Rear Quarter Panel, Near Bottom of Liftgate Opening	15
C321	BK	In Liftgate	20
C322	GN	In Liftgate	20
C323	GY	In Liftgate	20
C324	BK	In Liftgate	20
C325	BK	In Liftgate	20
C326	GY	In Liftgate	20
C328	GY	Left Rear Quarter Panel, Near Bottom of Liftgate Opening	16
C329	BK	Below Left Rear Seat	15
C330	GY	In Right Rear Door	18
C334	BK	In Right Front Door	17
C335	BK	Under Left Rear Passenger Seat	16
C343	BK	In Left Rear Door	18
C345	BK	In Right Rear Door	18
C351	GY	In Left Front Door	17
C353	BK	In Right Front Door	17
C359	BK	In Liftgate	20
C362	BK	In Liftgate	20
C364	BK	In Liftgate	20
C372	BK	Left Rear Quarter Panel	19
Camshaft Position Sensor	BK	Near Distributor	5, 9

DESCRIPTION AND OPERATION (Continued)

Connector Name/Number	Color	Location	Fig.
Cargo Lamp	BK	Rear of Cargo Lamp	16
Center High Mounted Stop Lamp Bulb No. 1	BK	At Lamp	N/S
Center High Mounted Stop Lamp Bulb No. 2	BK	At Lamp	N/S
Center High Mounted Stop Lamp Bulb No. 3	BK	At Lamp	N/S
Cigar Lighter	BK	Rear of Cigar Lighter	11
Cigar Lighter Lamp		At Lamp	11
Clockspring C1		At Clockspring Column Side	N/S
Clockspring C2		At Clockspring Column Side	N/S
Clutch Interlock Switch		Left Side of Steering Column	11
Controller Anti-Lock Brake C1	BK	At Anti-Lock Brake Controller	N/S
Crankshaft Position Sensor	BK	Right Rear of Engine 4.0L Engine Rear of Engine 5.2L Engine	5, 9
Data Link Connector	BK	Lower Right Instrument Panel	N/S
Daytime Running Lamp Module	BK	Right Fender Side Shield, Below PDC	N/S
Dome/Reading Lamp	NAT	Behind Dome Lamp	14
Downstream Heated Oxygen Sensor	BK	Above Rear of Catalytic Converter	7, 10
Driver Door Module C1	WT	In Right Front Door	17
Driver Door Module C2	BK	In Driver's Door	N/S

Connector Name/Number	Color	Location	Fig.
Driver Door Module C3	BK	In Driver's Door	N/S
Driver Heated Seat Back	BK	Under Driver's Seat	N/S
Driver Heated Seat Cushion	BK	Under Driver's Seat	N/S
Driver Lumbar Motor	BK	Under Driver's Seat	N/S
Driver Power Seat Front Riser Motor	RD	Under Driver's Seat	N/S
Driver Power Seat Front Riser Motor Sensor	BK	Under Driver's Seat	N/S
Driver Power Seat Horizontal Motor	BK	Under Driver's Seat	N/S
Driver Power Seat Horizontal Motor Sensor	BK	Under Driver's Seat	N/S
Driver Lumbar Sensor/Motor	BK	Under Driver's Seat	N/S
Driver Power Seat Lumbar Switch	BK	Under Driver's Seat	N/S
Driver Power Seat Rear Riser Motor	RD	Under Driver's Seat	N/S
Driver Power Seat Rear Riser Motor Sensor	BK	Under Driver's Seat	N/S
Driver Power Seat Recliner Motor	BK	Under Driver's Seat	N/S
Driver Power Seat Recliner Motor Sensor	BK	Under Driver's Seat	N/S
Driver Power Seat Switch	GN	Under Driver's Seat	N/S
Driver Seat Heater Control Module	BK	Under Driver's Seat	N/S
Driver Side Airbag	YL	Lower Instrument Panel	N/S
Duty Cycle EVAP/Purge Solenoid	BK	Front of Left Fender Side Shield	4

DESCRIPTION AND OPERATION (Continued)

Connector Name/Number	Color	Location	Fig.
Engine Coolant Level Sensor	BK	Top of Reserve Tank	3
Engine Coolant Temperature Sensor	BK	On Thermostat Housing Rear of Generator	5, 8
Engine Starter Motor	BK	At Starter Motor	6,8
Factory Trailer Tow Connector	BK	On Trailer Hitch	22
Floor Console Lamps	BK	Left Side of Center Floor Console	15
Four-Wheel Drive Switch	BK	Left Front of Transfer Case	7, 10
Fuel Heater	BK	At Fuel Heater/Filter	8
Fuel Injector #1	GY	At Injector	5
Fuel Injector #2	GY	At Injector	5
Fuel Injector #3	GY	At Injector	5
Fuel Injector #4	GY	At Injector	5
Fuel Injector #5	GY	At Injector	5
Fuel Injector #6	GY	At Injector	5
Fuel Pump Module	BK	Near Fuel Tank	15, 16
G100		Right Fender Side Shield	2
G101		Right Side of Engine Block 4.0L Engine	6
G104		Right Side of Engine Block 4.0L Engine	N/S
G104		Below A/C Compressor Diesel Engine	8
G105		Right Rear of Engine 4.0L Engine	5, 9
G106		Right Fender Side Shield	2,3
G107		Right Fender Side Shield	2,3
G108		Front of Left Fender Side Shield	4

Connector Name/Number	Color	Location	Fig.
G109		Front of Left Fender Side Shield	4
G110		Near Headlamp Leveling Motor	N/S
G300		Right Rear Quarter Panel	15
G301		Rear of Driver's Seat	15
G302		On Floor Pan Rear of Seat	16
G303		On Floor Pan Rear of Seat	16
G-Switch	BK	Below Right Rear Seat	15
Generator	BK	At Generator	6
Glove Box Lamp	BK	At Glove Box Lamp	12
Glow Plug Relay	BK	At PDC (Diesel Engine)	N/S
Graphic Display Module/Vehicle Information Center	BK	Rear of Vehicle Information Center (VIC)	12
Headlamp Leveling Switch	BK	At Switch	12
Headlamp Switch	BK	Rear of Headlamp Switch	11
High Speed Blower Motor Relay	BK	Right Side of HVAC	N/S
Horn No. 1	BK	At Horn, Lower Right Front of Vehicle	1
Horn No. 2	BK	At Horn, Lower Right Front of Vehicle	1
Idle Air Control Motor	BK	On Throttle Body	5
Ignition Coil	BK	Right Front of Engine	5
Ignition Switch	BK	On Steering Column	13
In-Car Temperature Sensor	BK	Center, Top of Instrument Panel	15

DESCRIPTION AND OPERATION (Continued)

Connector Name/Number	Color	Location	Fig.
Instrument Cluster	BK	Rear of Instrument Cluster	11
Intake Air Temperature Sensor	GY	On Intake Manifold	5
Junction Block - C1	RD	Behind Left Kick Panel	N/S
Junction Block - C2	BK	Behind Left Kick Panel	N/S
Junction Block - C3	BL	Behind Left Kick Panel	N/S
Junction Block - C4	TN	Behind Left Kick Panel	N/S
Junction Block - C5	RD	Behind Left Kick Panel	N/S
Junction Block - C6	BK	Behind Left Kick Panel	N/S
Junction Block - C7	BL	Behind Left Kick Panel	N/S
Junction Block - C8	YL	Behind Left Kick Panel	N/S
Junction Block - C9	BK	Behind Left Kick Panel	N/S
Junction Block - C10	LT GN	Behind Left Kick Panel	N/S
Junction Block Body Connector - C13	TN	Behind Left Kick Panel	N/S
Junction Block Body Connector - C14	BK	Behind Left Kick Panel	N/S
Key-In Switch/Halo Lamp	GY	On Steering Column, Near Ignition Switch	13
Lamp Outage Module C1	BK	Left Rear Quarter Panel, Near Bottom of Liftgate Opening	16
Lamp Outage Module C2	BK	Left Rear Quarter Panel, Near Bottom of Liftgate Opening	16
Left Back-Up Lamp	BK	At Lamp	N/S

Connector Name/Number	Color	Location	Fig.
Left Courtesy Lamp	BK	At Lamp	11
Left Door Courtesy Lamp	BK	In Left Front Door	17
Left Fog Lamp	BK	Left Fog Lamp	N/S
Left Front Cylinder Lock Switch	BK	In Left Front Door	17
Left Front Door Ajar Switch		At Left B-Pillar	16
Left Front Door Lock Motor	BK	In Left Front Door	17
Left Front Door Speaker	BK	In Left Front Door	17
Left Front Park Lamp	WT	At Lamp	N/S
Left Front Power Window Motor	BK	In Left Front Door	17
Left Front Side Marker Lamp	GY	At Lamp	N/S
Left Front Turn Signal Lamp	BK	At Lamp	N/S
Left Front Wheel Speed Sensor	BK	Left Rear Corner of Engine Compartment	N/S
Left Headlamp	BK	Rear of Headlamp	1
Left Headlamp Leveling Motor	BK	At Headlamp	1
Left Instrument Panel Speaker	BK	Rear of Left Instrument Panel Speaker	11
Left License Lamp	NAT	In Liftgate Behind License Plate Lamps	22
Left Rear Door Ajar Switch		Rear of Left Door	16
Left Rear Door Lock Motor	BK	In Left Rear Door	18
Left Rear Door Speaker	BK	In Left Rear Door	18
Left Rear Power Window Motor	BK	In Left Rear Door	18
Left Rear Power Window switch	BL	In Left Rear Door	18

DESCRIPTION AND OPERATION (Continued)

Connector Name/Number	Color	Location	Fig.
Left Rear Side Marker Lamp	NAT	At Lamp	N/S
Left Rear Turn Signal Lamp	BK	At Lamp	N/S
Left Rear Wheel Speed Sensor	BK	Below Left Rear Passenger Seat	15
Left Side Repeater Lamp	BK	At Lamp	N/S
Left Tail/Stop Lamp	BK	At Lamp	N/S
Left Visor/Vanity Mirror	BK	Top of Left A-Pillar	14
Liftgate Ajar Switch	BK	In Liftgate	20
Liftgate Cylinder Lock Switch	BK	In Liftgate	20
Liftgate Lock Motor	BK	In Liftgate	20
Liftglass Ajar Switch	BK	In Liftgate	20
Liftglass Limit Switch	NAT	In Liftgate	20
Liftglass Push Button	BK	In Liftgate	20
Liftglass Release Solenoid	BK	In Liftgate	20
Low Washer Fluid Level Sensor	BK	At Washer Reservoir	4
Manifold Absolute Pressure Sensor	BK	On Throttle Body	5
Memory Seat Module Connector C1	BK	At Driver's Seat	N/S
Memory Seat Module Connector C2	BK	At Driver's Seat	N/S
Mini Overhead Console	GY	Under Front Seat	N/S
Mode Door Motor	BK	Left Side of HVAC	N/S
Multi-Function Switch	BK	On Steering Column	13

Connector Name/Number	Color	Location	Fig.
Oil Pressure Sensor	BK	Near Distributor	5, 9
Output Shaft Speed Sensor	BK	Left Side of Transmission	7, 10
Overhead Console	RD	Center of Headliner, Above Rear View Mirror	14
Overhead Console Junction Block	BK	Behind Kick Panel, At Junction Block	N/S
Park Brake Switch		At Park Brake	15
Park/Neutral Position Switch	BK	Left Side of Transmission	7, 10
Passenger Airbag	YL	Behind Passenger Airbag	11
Passenger Door Module	WT	In Left Front Door	17
Passenger Heated Seat Back	GN	Under Passenger's Seat	N/S
Passenger Heated Seat Cushion	BK	Under Passenger's Seat	N/S
Passenger Lumbar Motor	BK	Under Passenger's Seat	N/S
Passenger Lumbar Switch	WT	Under Passenger's Seat	N/S
Passenger Power Seat Front Riser Motor	RD	Under Passenger's Seat	N/S
Passenger Power Seat Horizontal Motor	BK	Under Passenger's Seat	N/S
Passenger Power Seat Rear Riser Motor	RD	Under Passenger's Seat	N/S
Passenger Power Seat Recliner Motor	BK	Under Passenger's Front Seat	N/S
Passenger Power Seat Switch	BK	Under Passenger's Front Seat	N/S

DESCRIPTION AND OPERATION (Continued)

Connector Name/Number	Color	Location	Fig.
Passenger Seat Heater Control Module	GY	Under Passenger's Seat	N/S
Pedal Position Sensor		Lower Right of Instrument Panel	N/S
Power Amplifier C1	WT	Below Right Rear Passenger Seat	15
Power Amplifier C2	WT	Below Right Rear Passenger Seat	15
Power Antenna Motor	BK	At Antenna	N/S
Power Distribution Center		Right of Engine Compartment	2
Power Outlet	BK	Rear of Power Outlet	11
Powertrain Control Module C1	BK	Right Rear Corner of Engine Compartment At PCM	3
Powertrain Control Module C2	WT	Right Rear Corner of Engine Compartment At PCM	3
Powertrain Control Module C3	GY	Right Rear Corner of Engine Compartment At PCM	3
Radio C1	GY	Rear of Radio	11
Radio C2	BK	Rear of Radio	11
Rear Washer Pump Motor	BK	Bottom of Windshield Washer Fluid Reservoir	4
Rear Wiper Motor	BK	In Liftgate	20
Rear Wiper/Washer Switch	BK	Behind Rear Wiper Switch	11
Recirculation Door Motor	YL	Top of HVAC	N/S
Right Back-Up Lamp	BK	At Lamp	N/S

Connector Name/Number	Color	Location	Fig.
Right Courtesy Lamp	BK	Right Courtesy Lamp	12
Right Door Courtesy Lamp	BK	In Right Front Door	17
Right Fog Lamp	BK	Rear of Fog Lamp	1
Right Front Cylinder Lock Switch	BK	In Right Front Door	N/S
Right Front Door Ajar Switch		At Right B-Pillar	N/S
Right Front Door Lock Motor	BK	In Right Front Door	17
Right Front Door Speaker	BK	In Right Front Door	17
Right Front Park Lamp	WT	At Lamp	N/S
Right Front Power Window Motor	BK	In Right Front Door	17
Right Front Side Marker Lamp	GY	At Lamp	N/S
Right Front Turn Signal Lamp	BK	At Lamp	N/S
Right Front Wheel Speed Sensor	BK	Right Rear Corner of Engine Compartment	2
Right Headlamp	BK	Rear of HeadLamp	1
Right Headlamp Leveling Motor	BK	At Headlamp	1,2
Right Instrument Panel Speaker	BK	Top Right of Instrument Panel	11
Right License Lamp	NAT	In Liftgate, Behind License Plate Lamps	22
Right Rear Door Ajar Switch		Rear of Door	N/S
Right Rear Door Lock Motor	BK	In Right Rear Door	18
Right Rear Door Speaker	BK	In Right Rear Door	18

DESCRIPTION AND OPERATION (Continued)

Connector Name/Number	Color	Location	Fig.
Right Rear Power Window Motor	BK	In Right Rear Door	18
Right Rear Power Window Switch	BL	In Right Rear Door	18
Right Rear Side Marker Lamp	NAT	At Lamp	N/S
Right Rear Turn Signal Lamp	BK	At Lamp	N/S
Right Rear Wheel Speed Sensor	RD	Below Right Rear Passenger Seat	15
Right Side Repeater Lamp	BK	At Lamp	N/S
Right Tail/Stop Lamp	BK	At Lamp	N/S
Right Visor/Vanity Mirror	BK	Top of Right A-Pillar	14
Seat Belt Switch	BK	Near Bottom of Driver's Seat Belt Clasp	N/S
Shift Interlock	BK	Steering Column, On Shift Cable	12
Solar Sensor	RD	Above Glove Box	11
Stop Lamp Switch	GY	Top of Brake Pedal Arm	12
Sunroof Control Module	BK	Rear of Sunroof	N/S
Sunroof Motor	BK	Rear of Sun Roof	N/S
Sunroof Switch	NAT	Center of Headliner, Above Rear View Mirror	14
Switch Pod	BK	Rear of Overdrive Switch	12

Connector Name/Number	Color	Location	Fig.
Throttle Position Sensor	BK	On Throttle Body	5
Trailer Tow Circuit Breaker	BK	Right Rear Quarter Panel	19
Trailer Tow Left Turn Relay	BK	Right Rear Quarter Panel	19
Trailer Tow Right Turn Relay	BK	Right Rear Quarter Panel	19
Trailer Tow Stop Lamp Relay	BK	Right Rear Quarter Panel	19
Transmission Solenoid Assembly	BK	Left Side of Transmission	7, 10
Underhood Lamp	BK	On Underside of Hood	21
Upstream Heated Oxygen Sensor	GY	Right Front of Transmission	5
Vehicle Speed Control Servo	BK	At Servo	N/S
Vehicle Speed Control/Horn Switch	NAT	On Steering Column	13
Vehicle Speed Sensor	BK	Rear of Transfer Case	7, 10
Windshield Washer Fluid Level Sensor		Top of Reservoir	4
Windshield Washer Pump Motor	BK	Bottom of Windshield Washer Fluid Reservoir	4
Windshield Wiper Motor	BK	Center of Cowl	4

DESCRIPTION AND OPERATION (Continued)

80b3c906

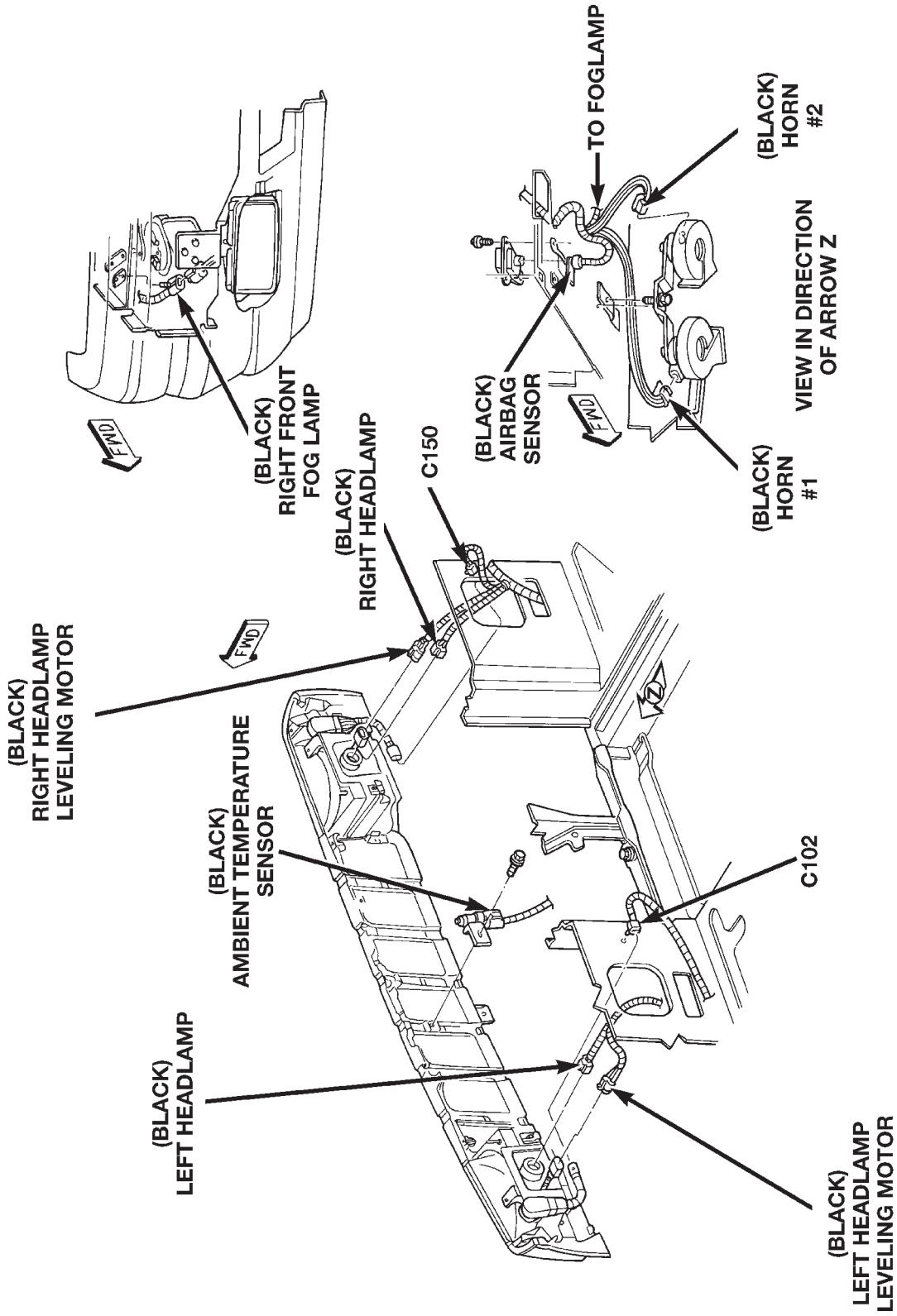


Fig. 1 Front End Lighting — RHD

DESCRIPTION AND OPERATION (Continued)

80b3c921

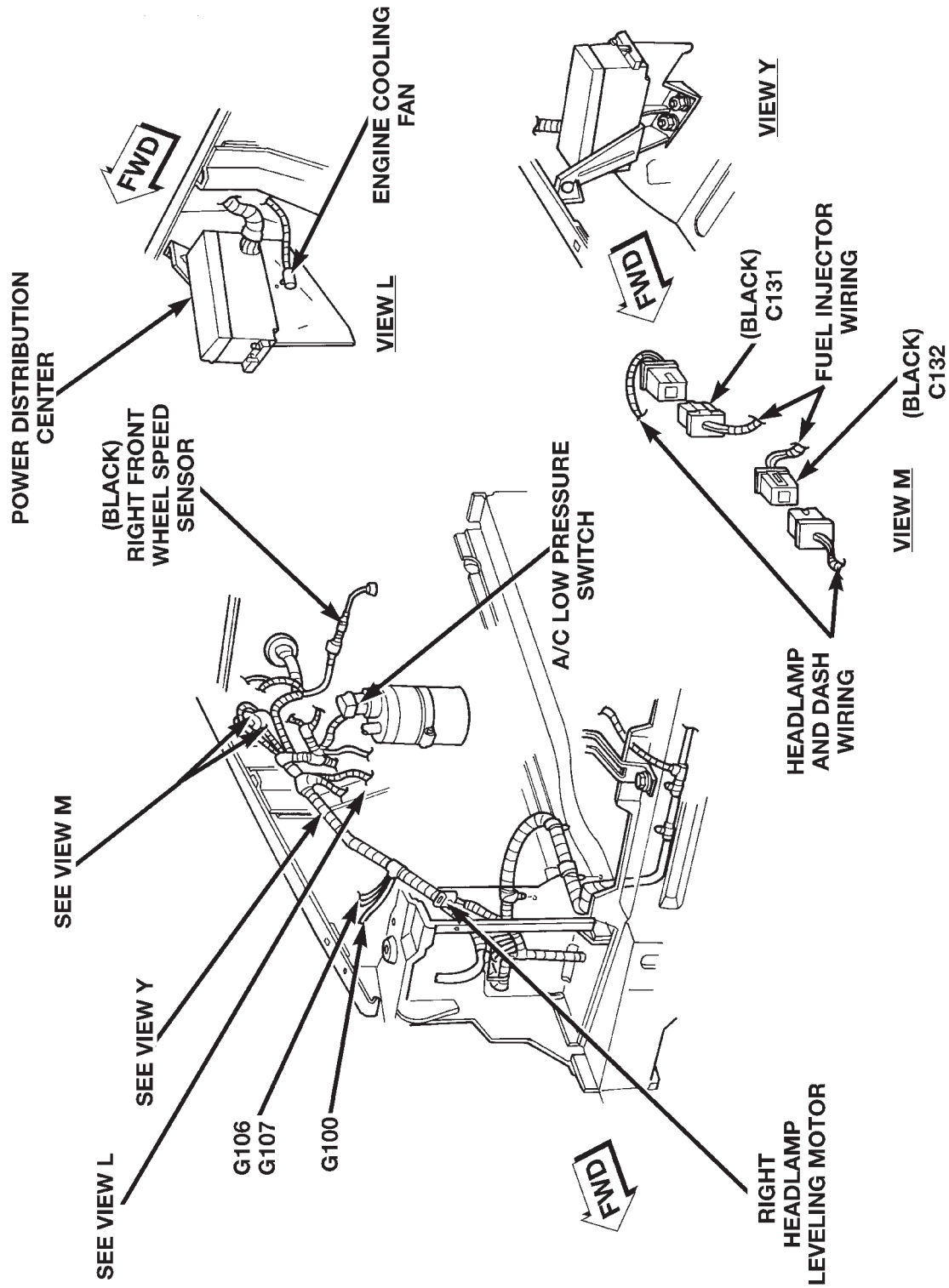


Fig. 2 Engine Compartment—Right Side, RHD

DESCRIPTION AND OPERATION (Continued)

80b3c922

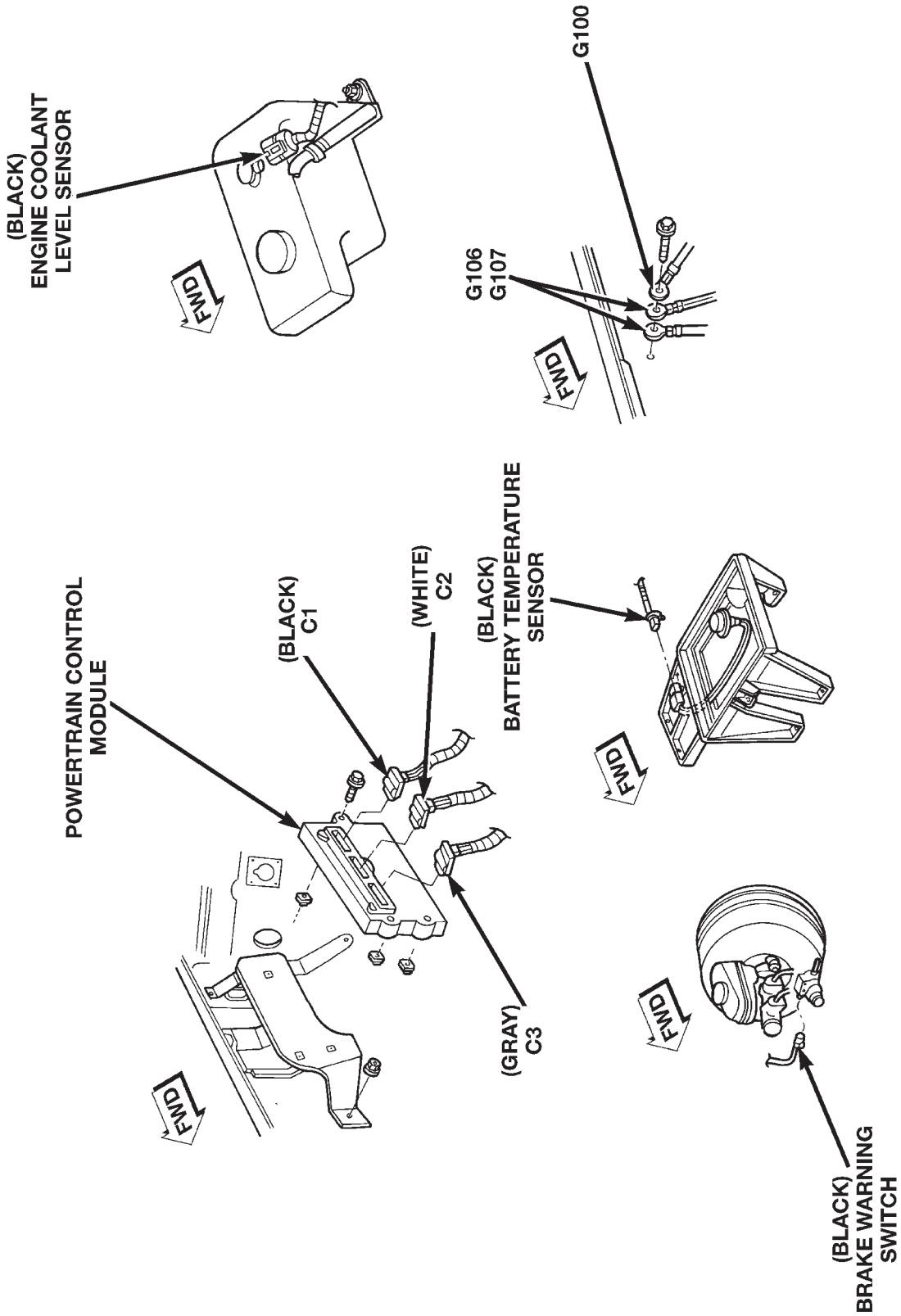


Fig. 3 Engine Compartment — RHd

DESCRIPTION AND OPERATION (Continued)

80b3c923

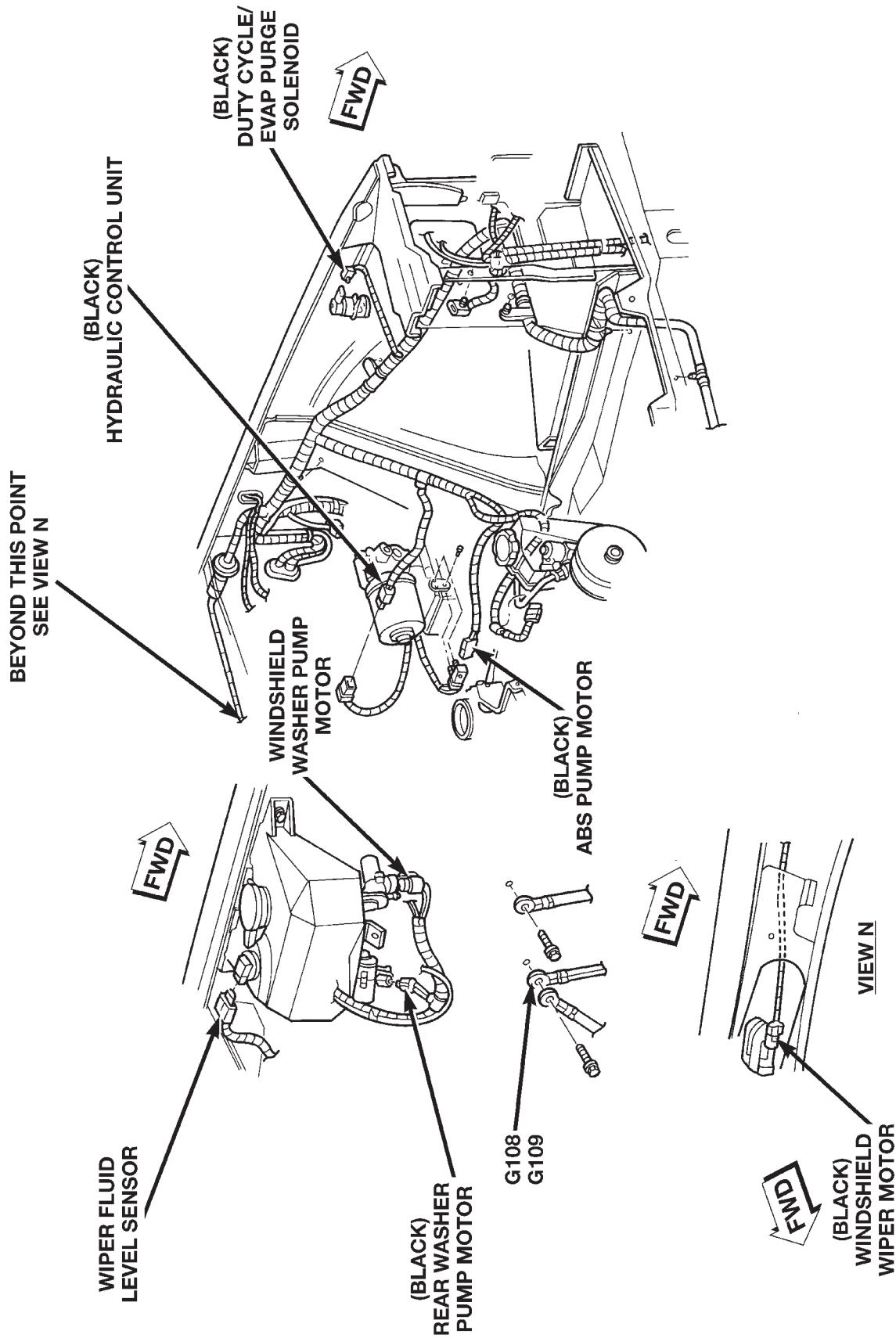
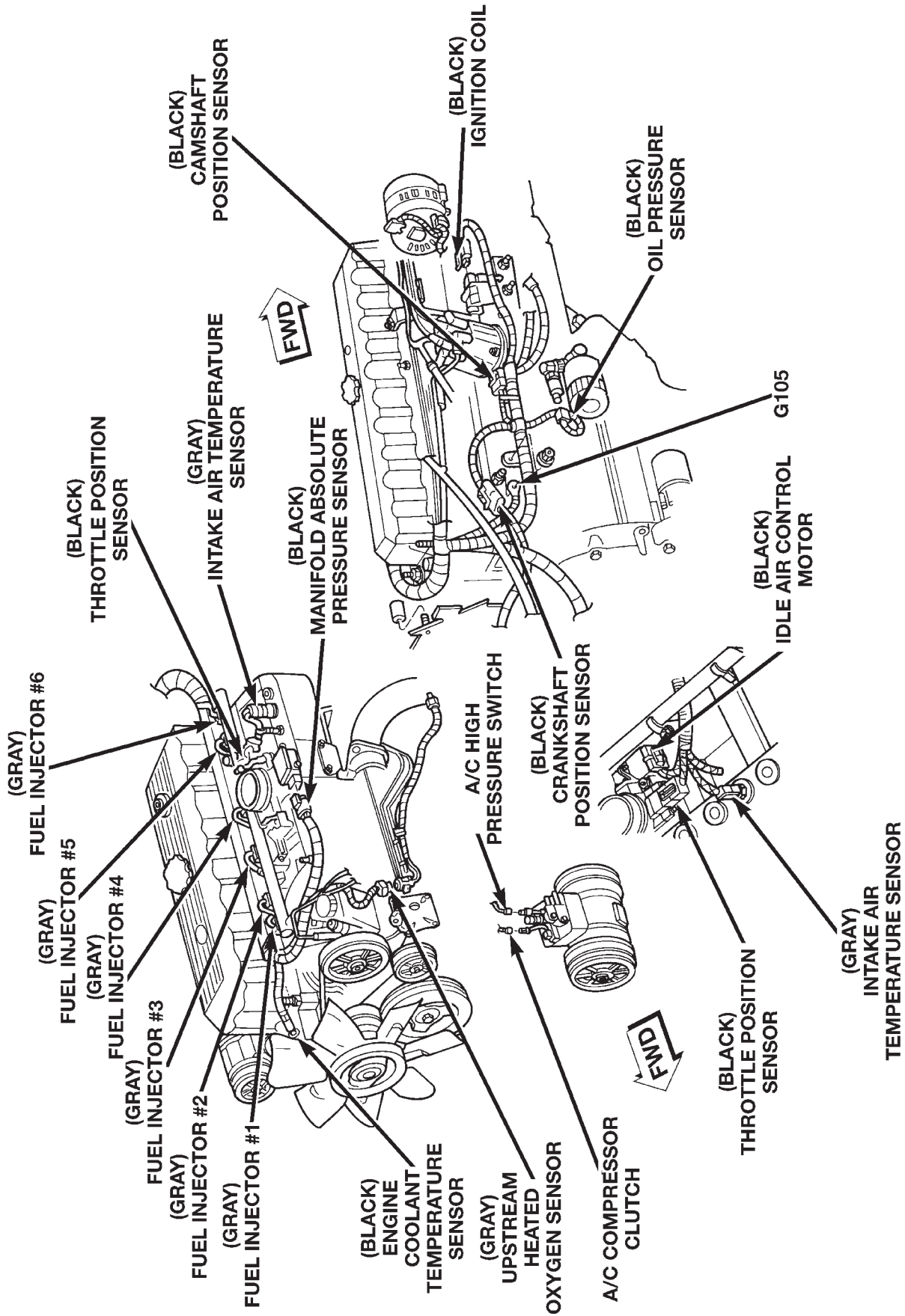


Fig. 4 Engine Compartment — Left Side, RHD

DESCRIPTION AND OPERATION (Continued)



8063c924

Fig. 5 Engine Connectors—4.0L Engine, RHD

DESCRIPTION AND OPERATION (Continued)

80b3c925

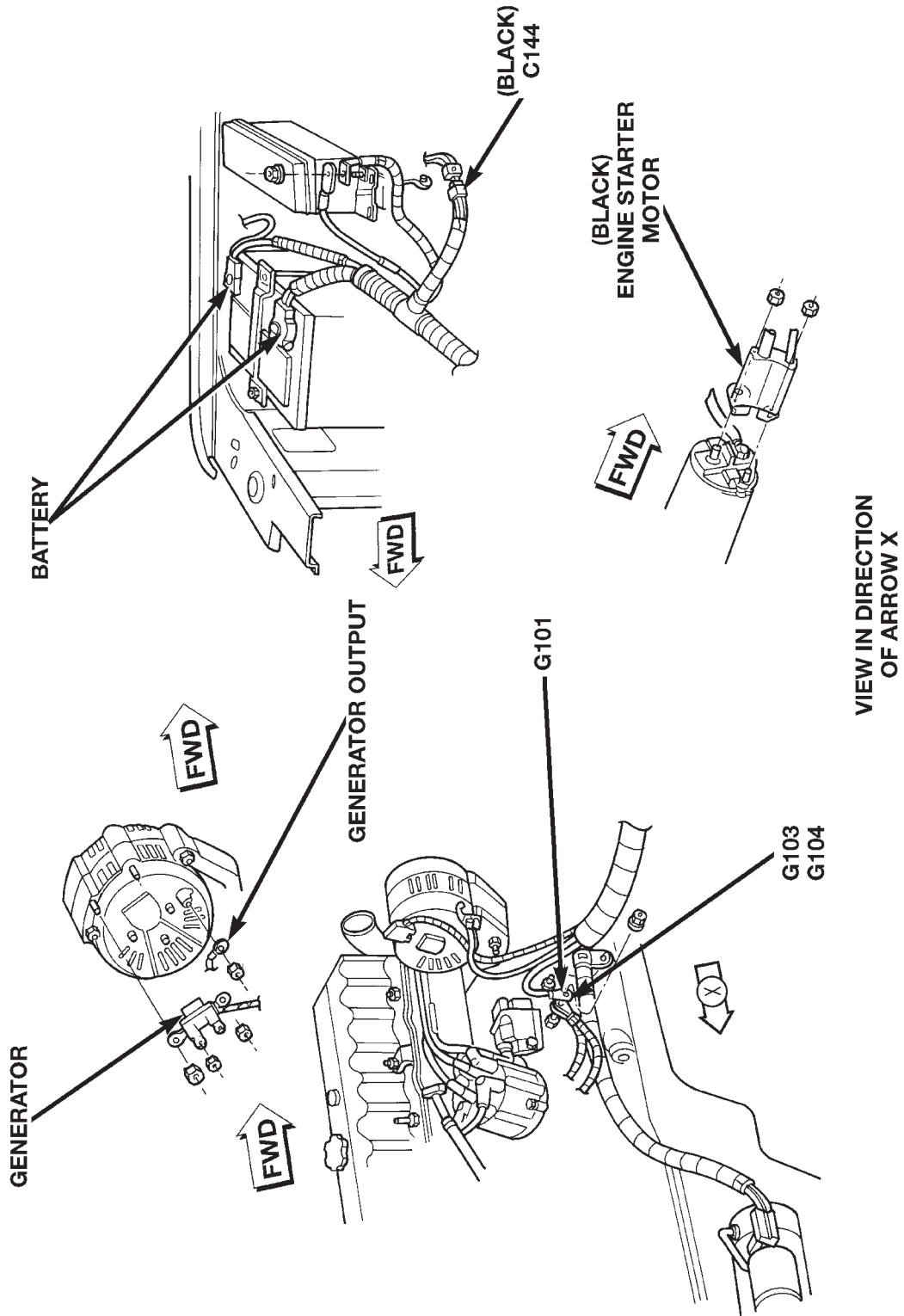
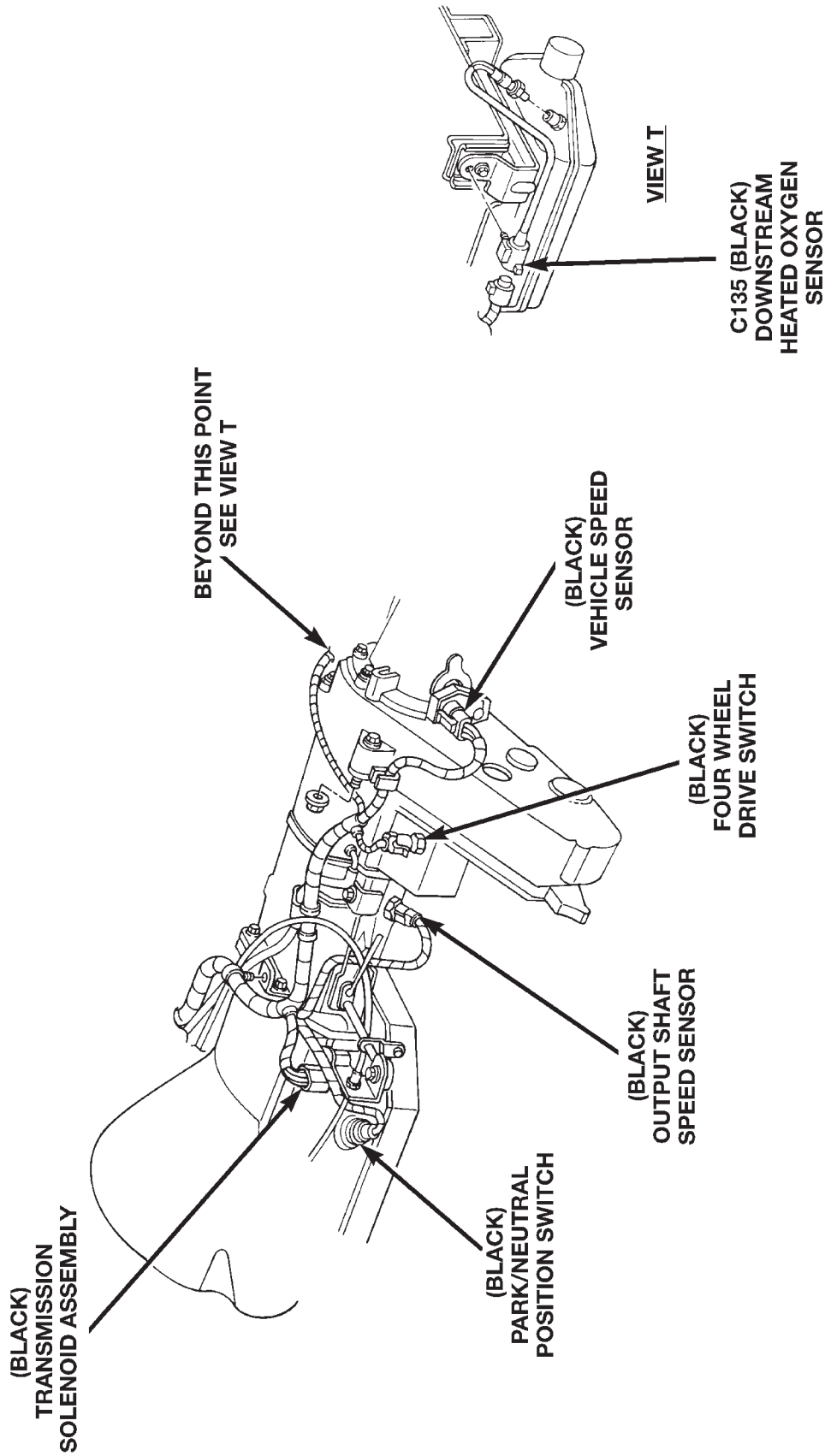


Fig. 6 Charging System Connectors — 4.0L Engine, RHD

DESCRIPTION AND OPERATION (Continued)



80a8376c

Fig. 7 Transmission Connectors—4.0L Engine, RHD

DESCRIPTION AND OPERATION (Continued)

80b3c912

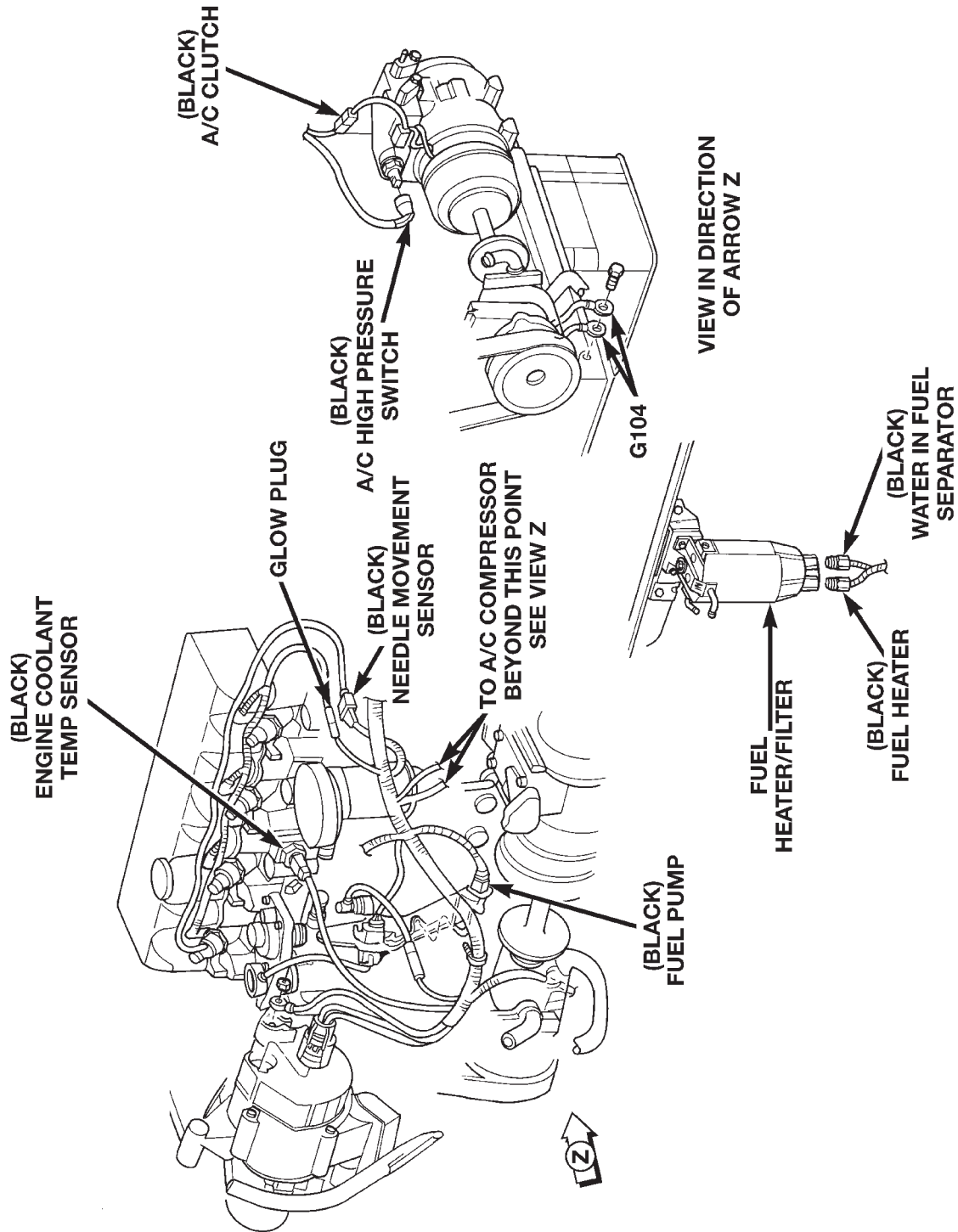


Fig. 8 Engine Connectors — Diesel Engine, RHD

DESCRIPTION AND OPERATION (Continued)

8053c913

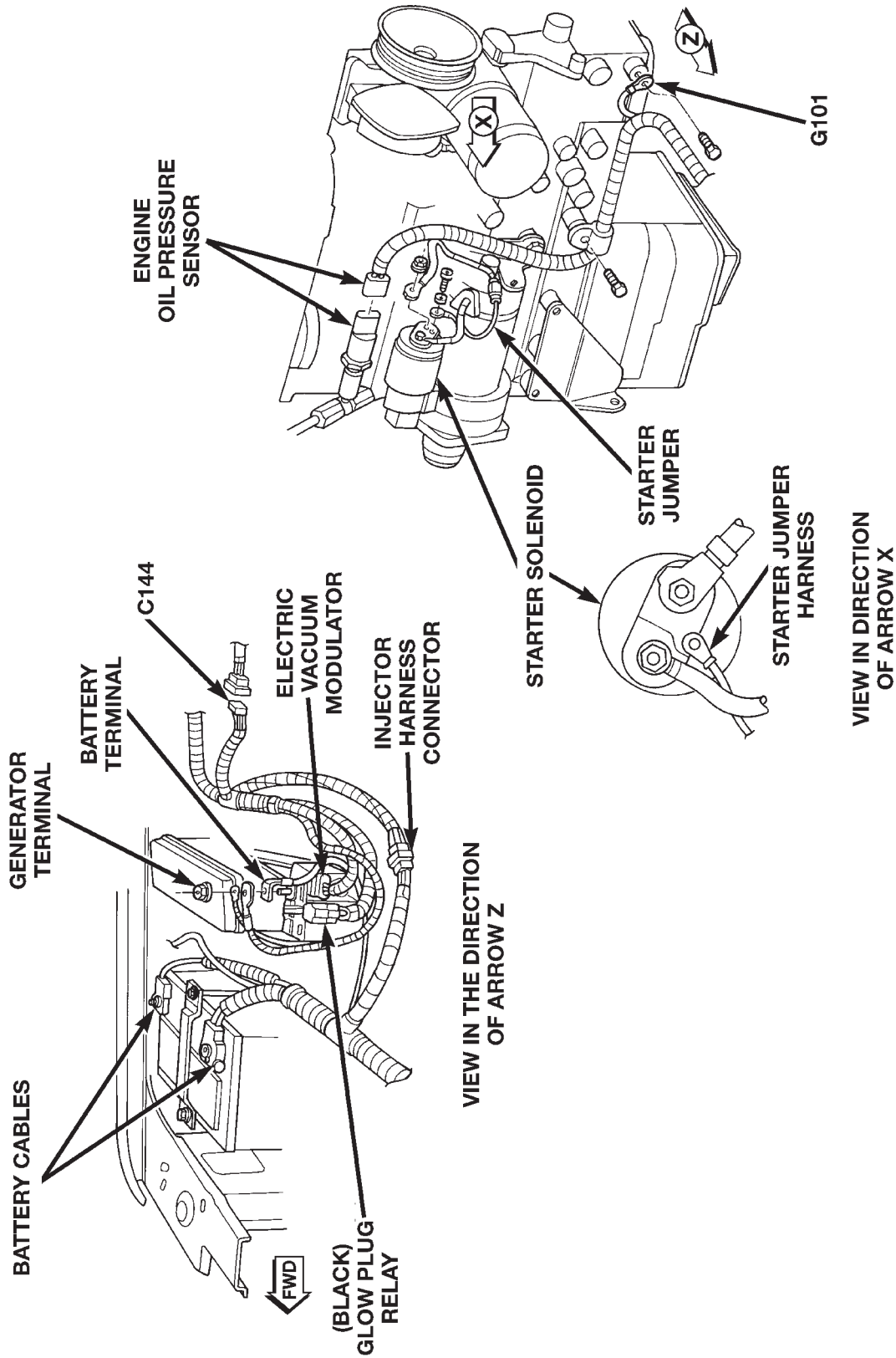


Fig. 9 Battery and Starter Motor—Diesel Engine, RHD

DESCRIPTION AND OPERATION (Continued)

8053c914

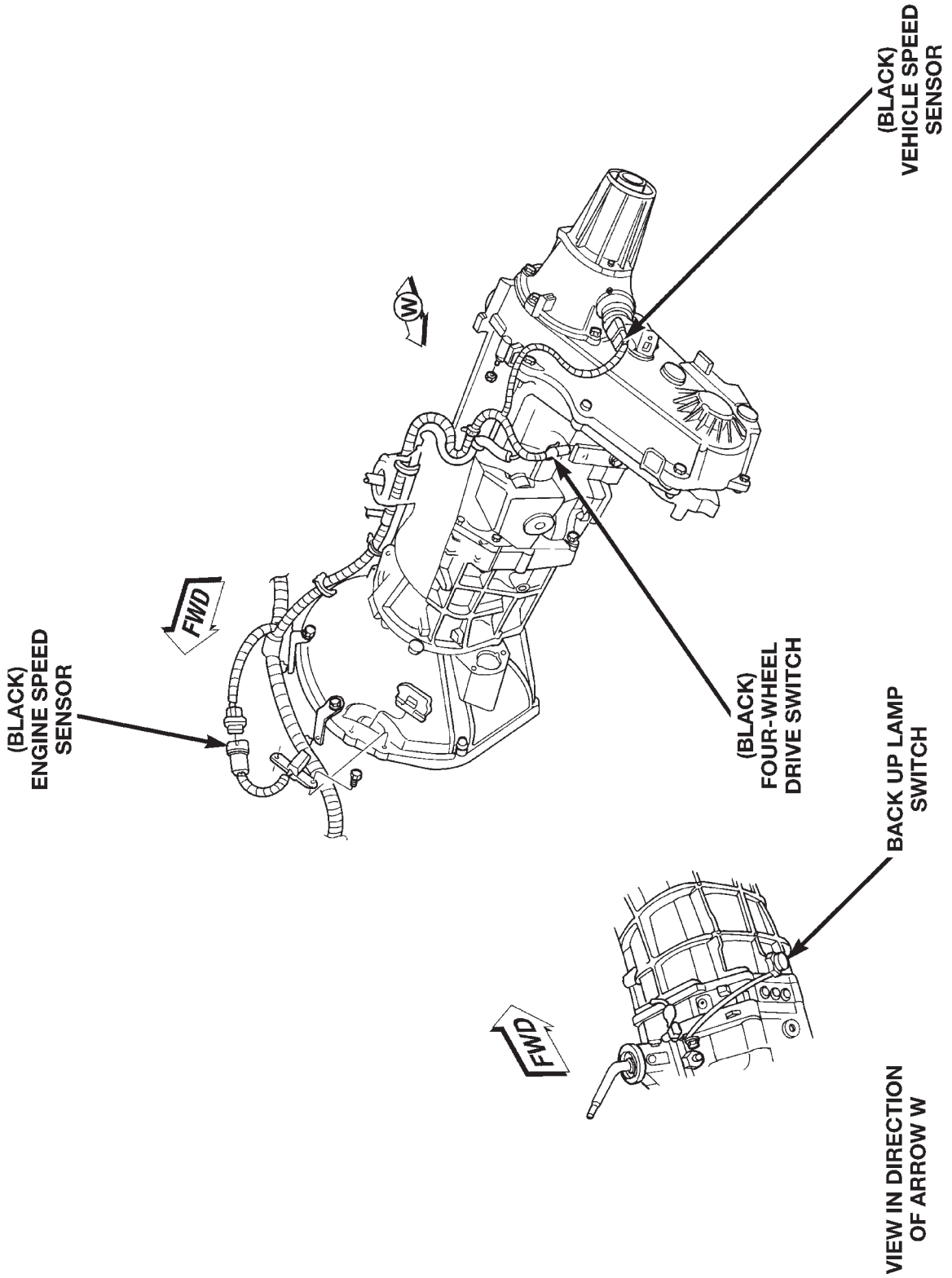


Fig. 10 Transmission Connectors—Diesel Engine, RHD

DESCRIPTION AND OPERATION (Continued)

80b3c927

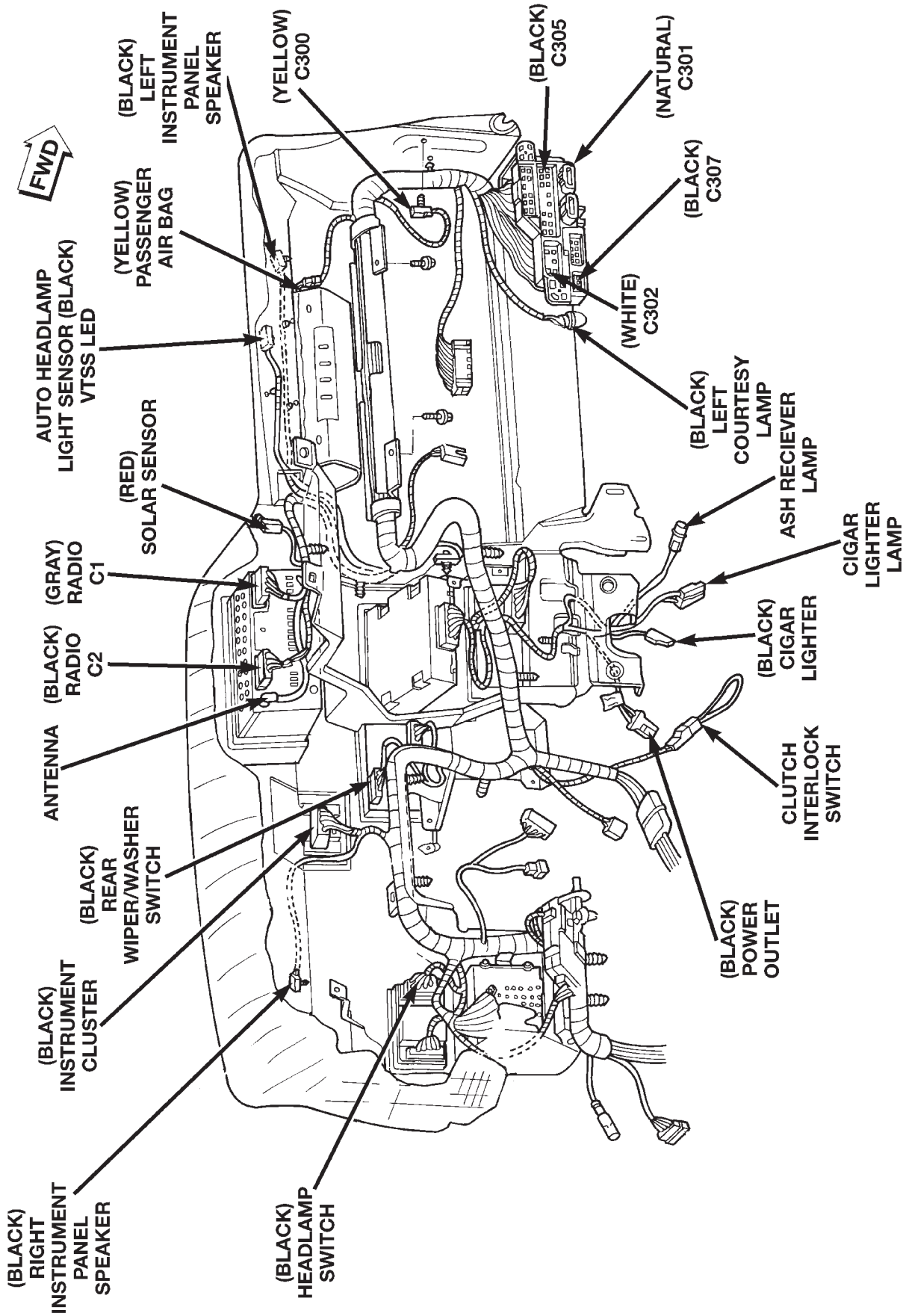


Fig. 11 Instrument Panel Connectors—RHD

DESCRIPTION AND OPERATION (Continued)

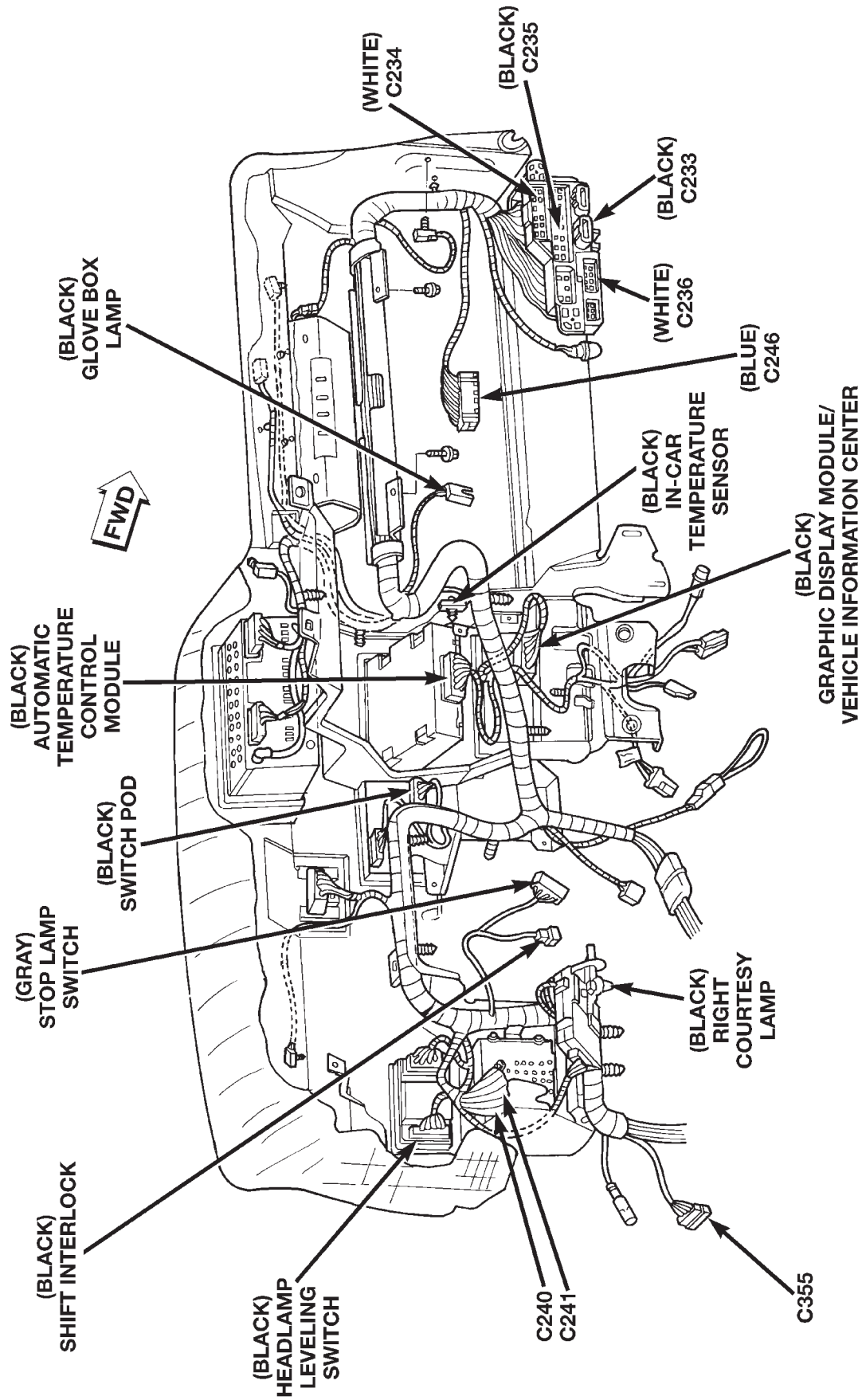


Fig. 12 Instrument Panel Connectors—RHD

DESCRIPTION AND OPERATION (Continued)

80b3c918

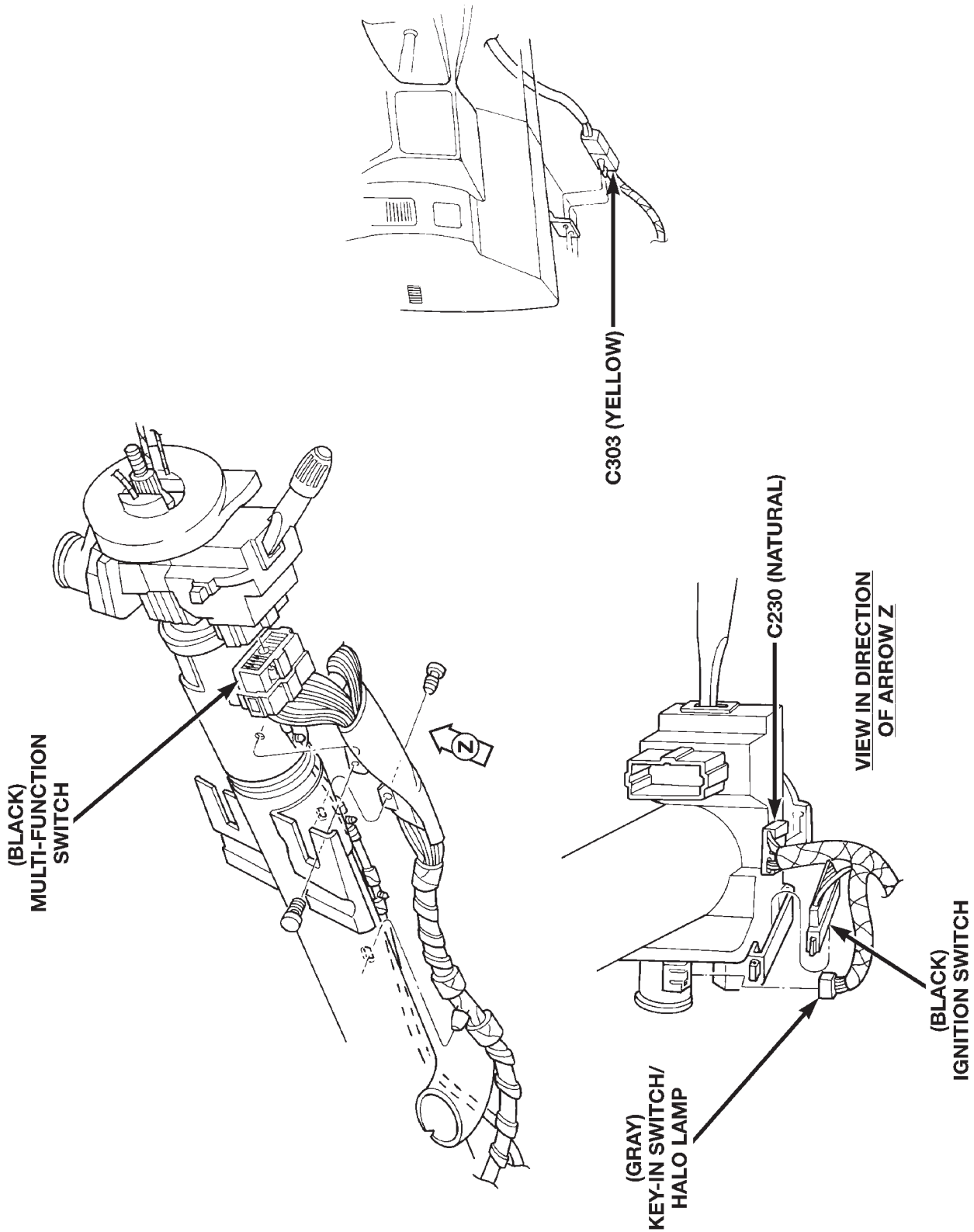


Fig. 13 Steering Column Connectors—RHD

DESCRIPTION AND OPERATION (Continued)

80b3c919

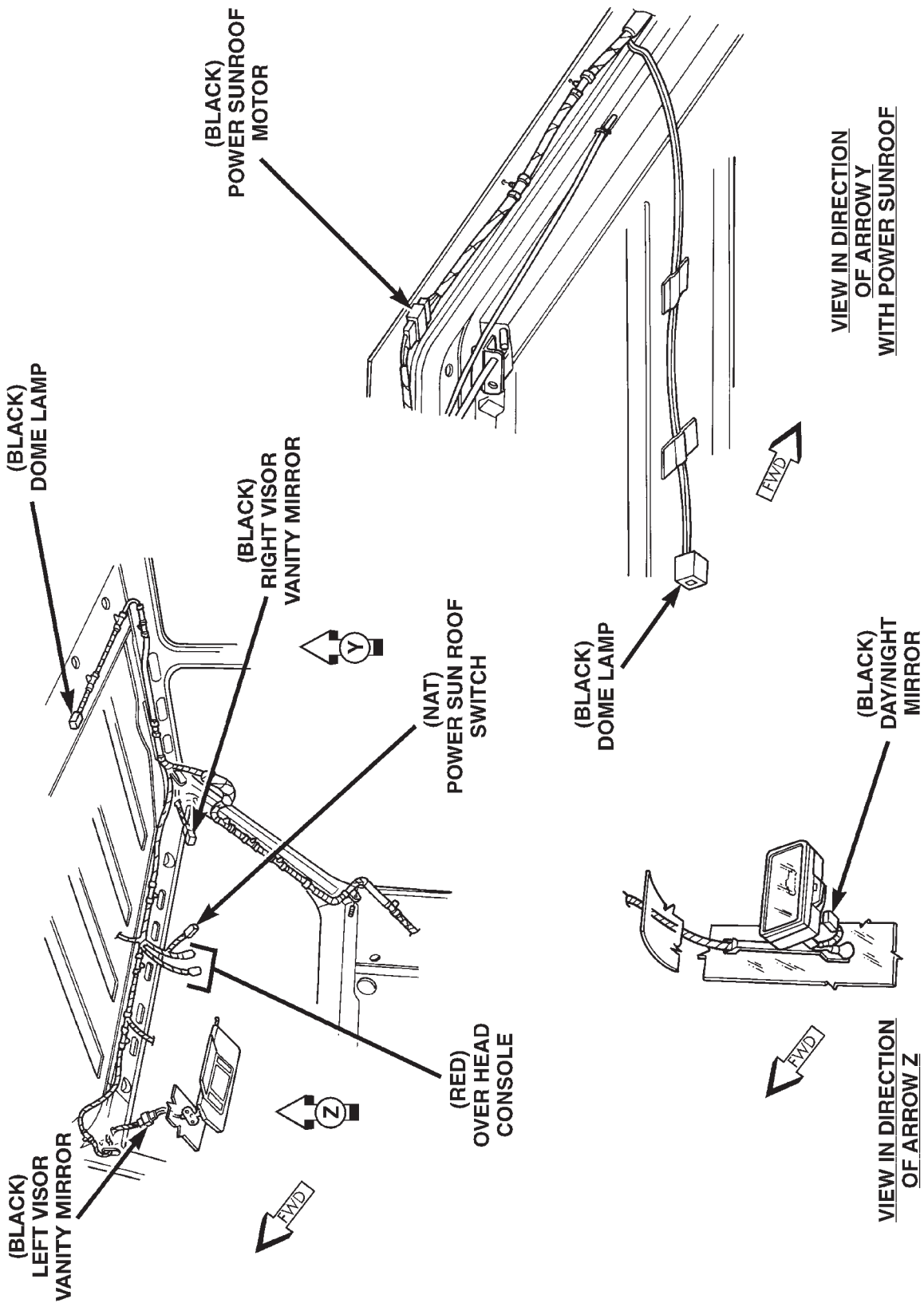


Fig. 14 Roof Connectors — RHD

DESCRIPTION AND OPERATION (Continued)

80b3c91a

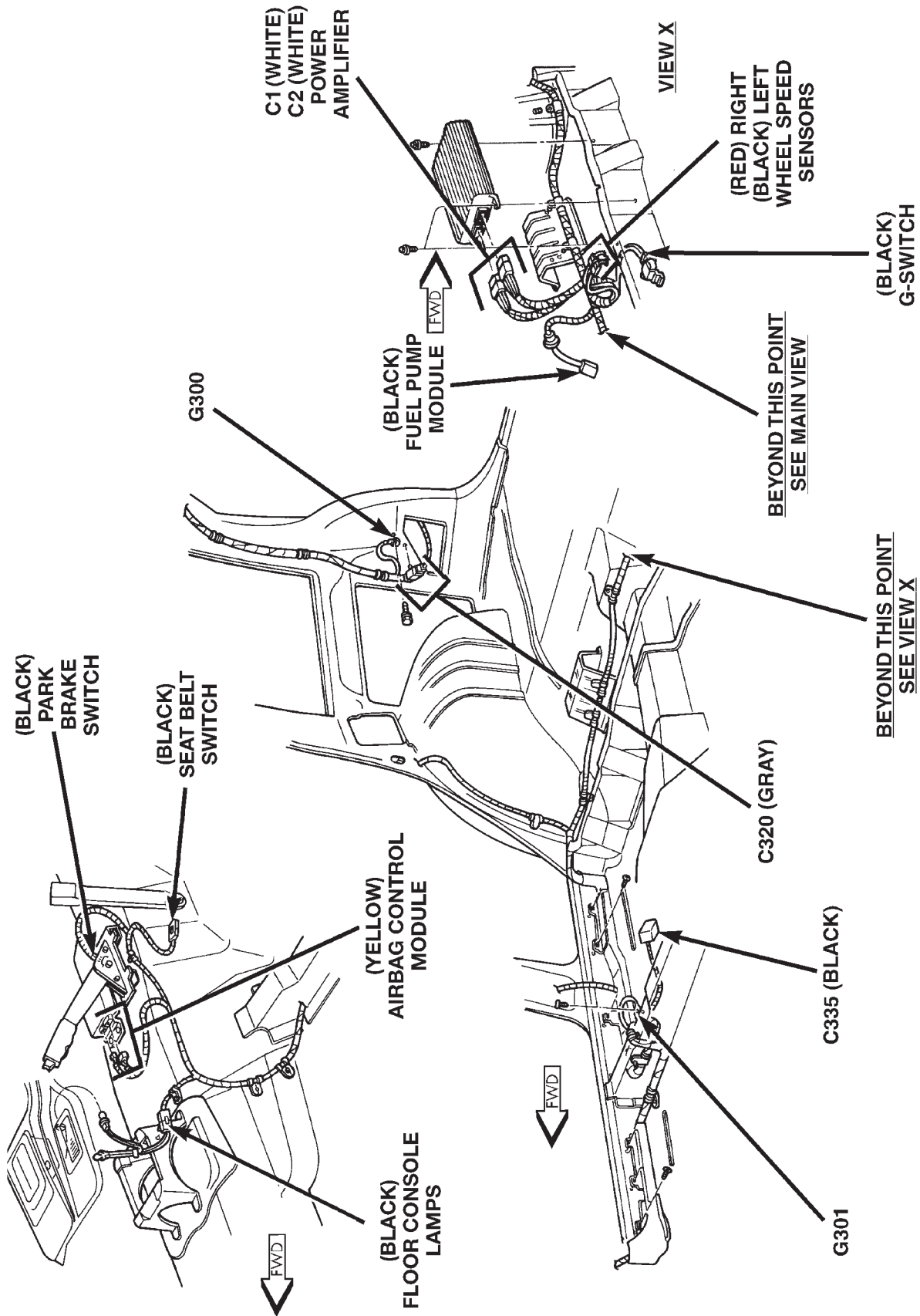
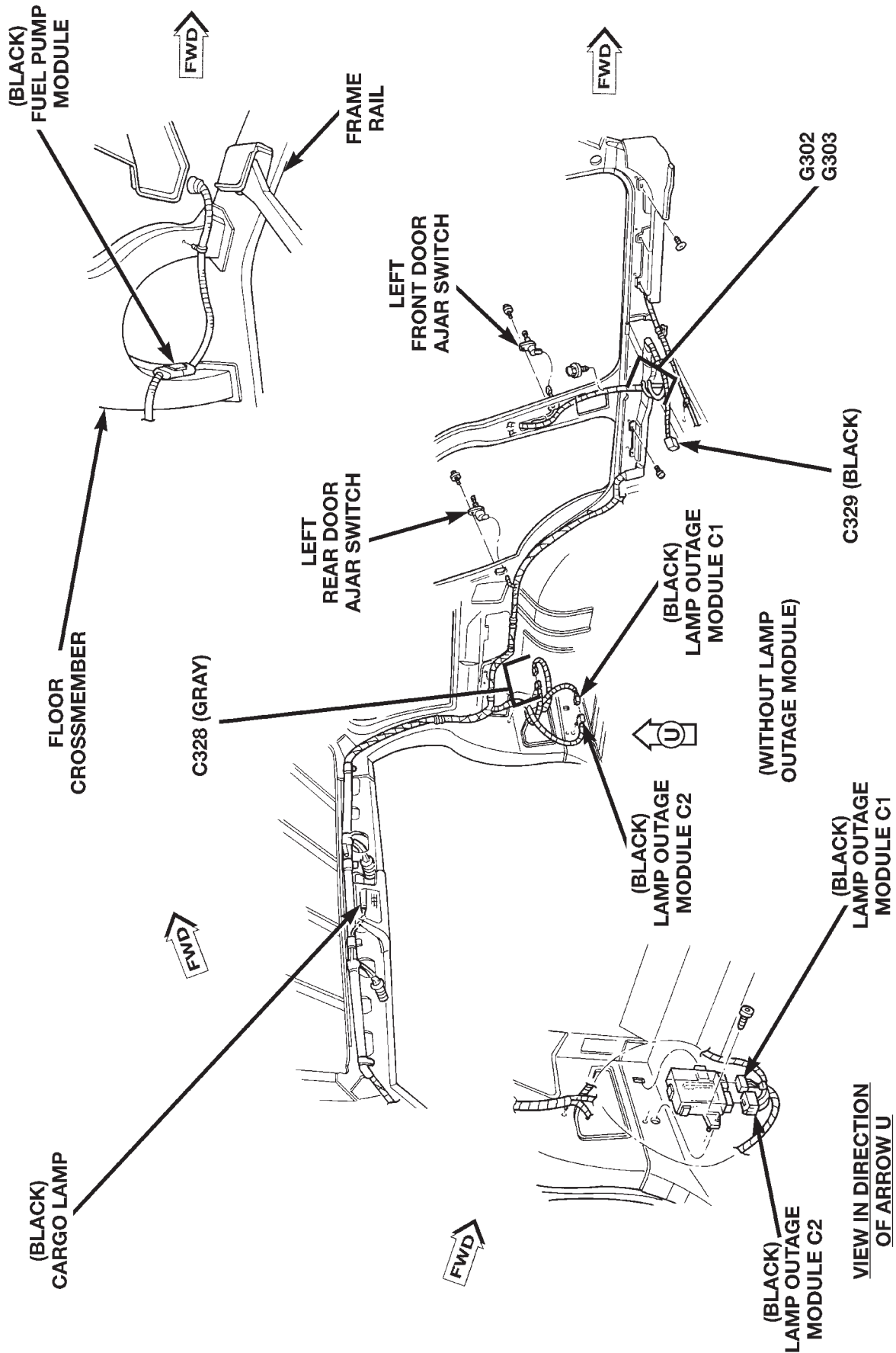


Fig. 15 Body Connectors — Right Side, RHD

DESCRIPTION AND OPERATION (Continued)



80b3c91b

Fig. 16 Body Connectors—Left Side, RHD

DESCRIPTION AND OPERATION (Continued)

80b3c91c

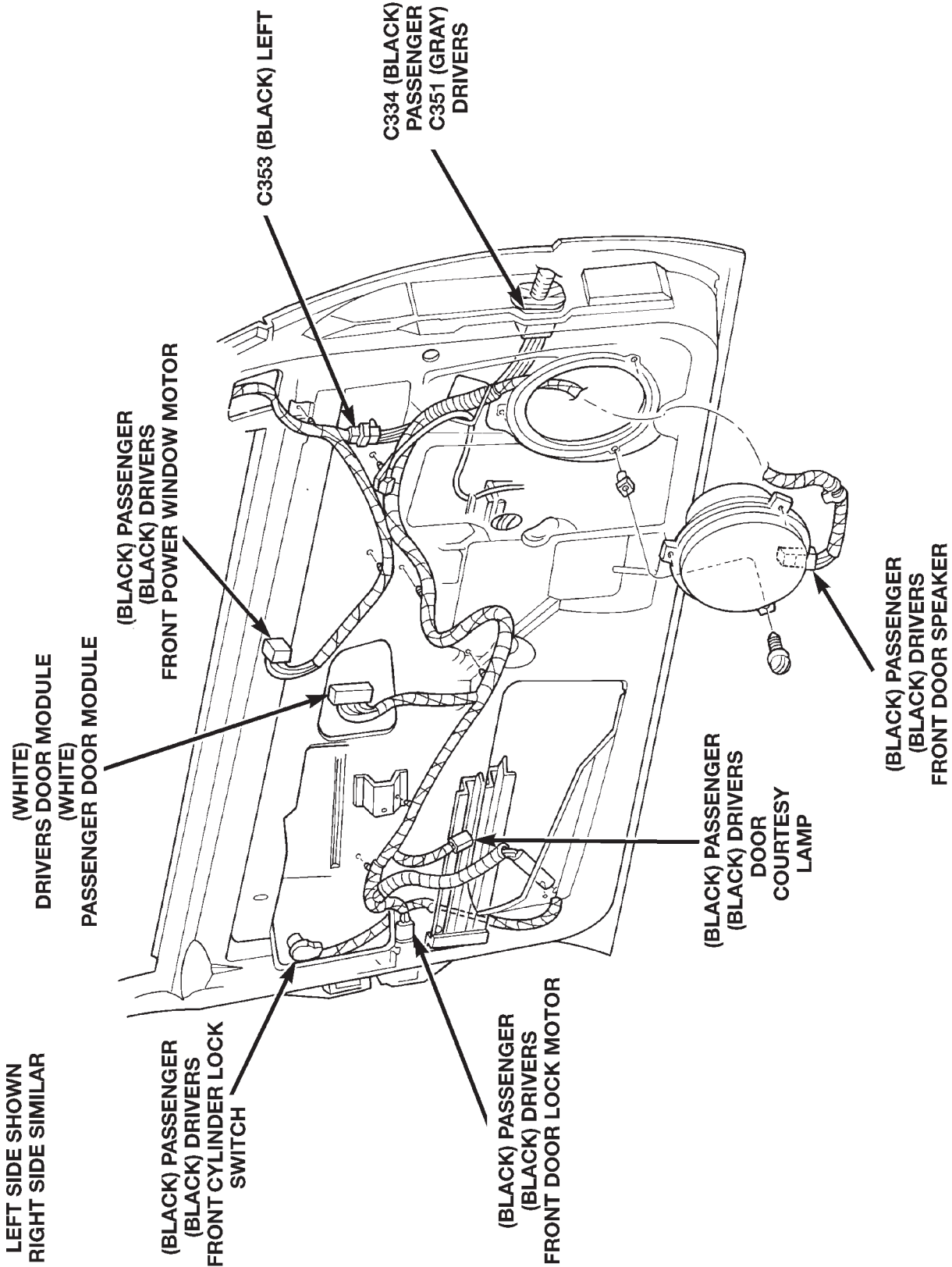
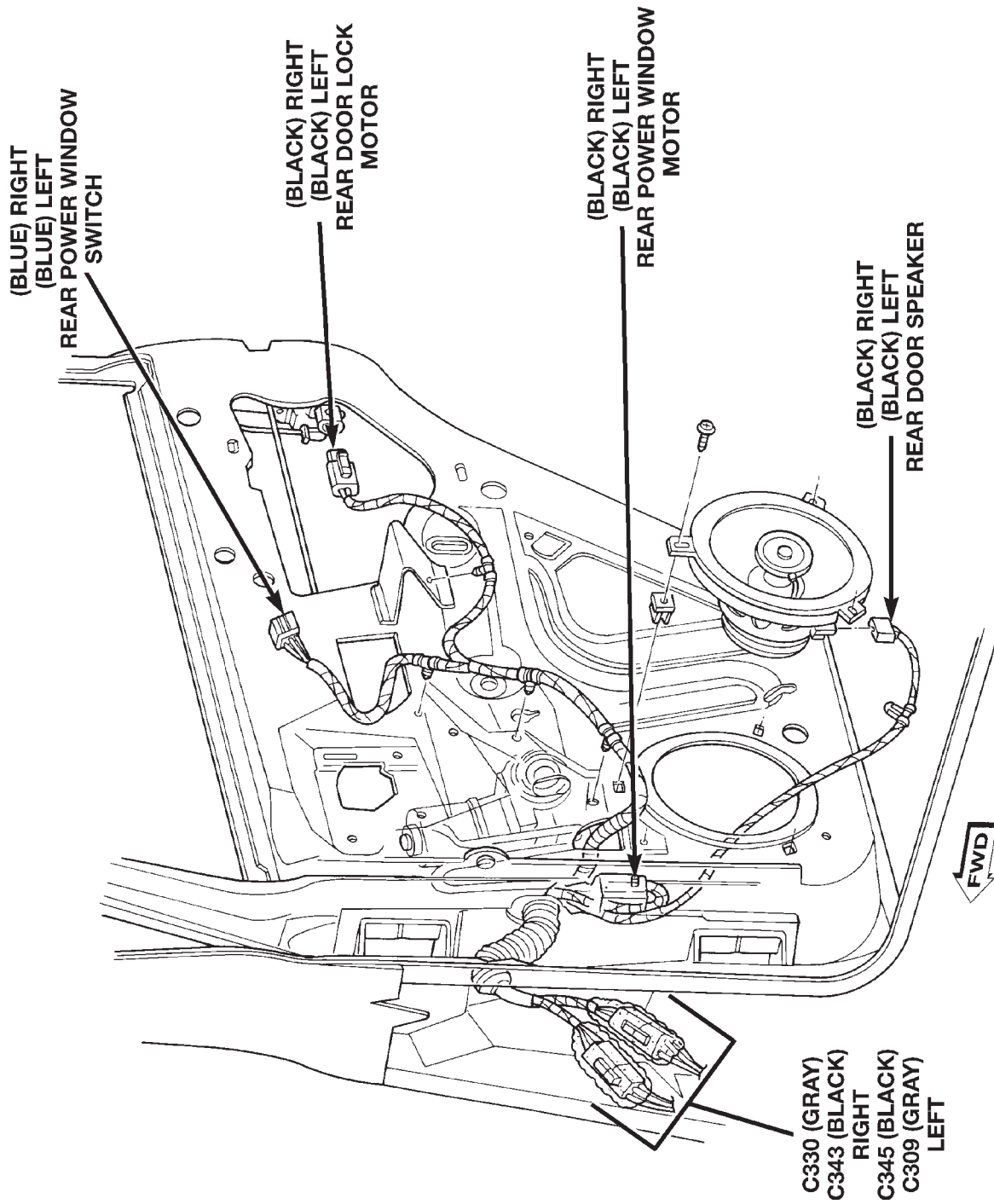


Fig. 17 Front Door Connectors — RHD

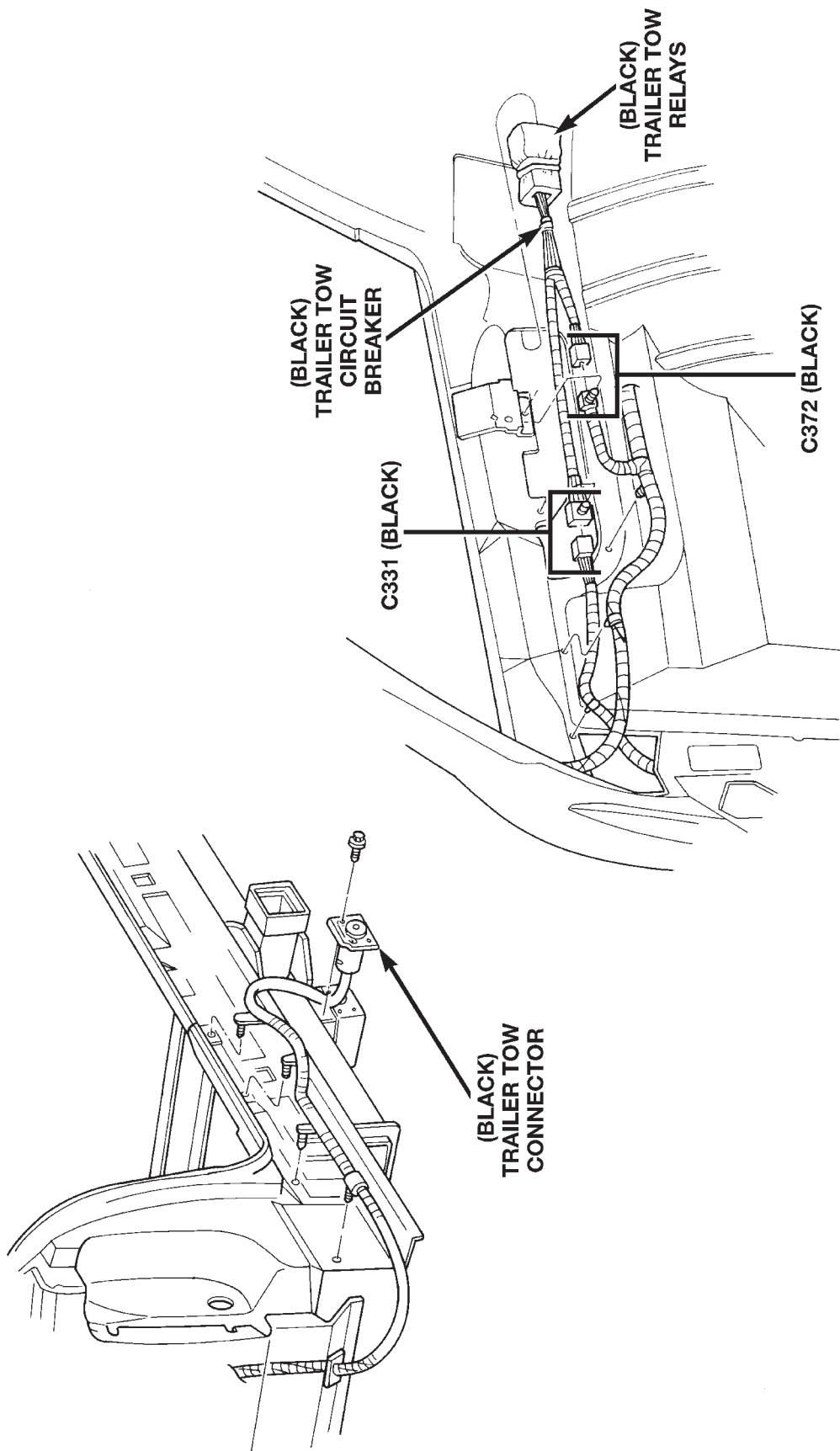
DESCRIPTION AND OPERATION (Continued)



80b3c91e

Fig. 18 Rear Door Connectors — RHD

DESCRIPTION AND OPERATION (Continued)



80b3c91f

Fig. 19 Factory Trailer Tow—RHD

DESCRIPTION AND OPERATION (Continued)

80f3c920

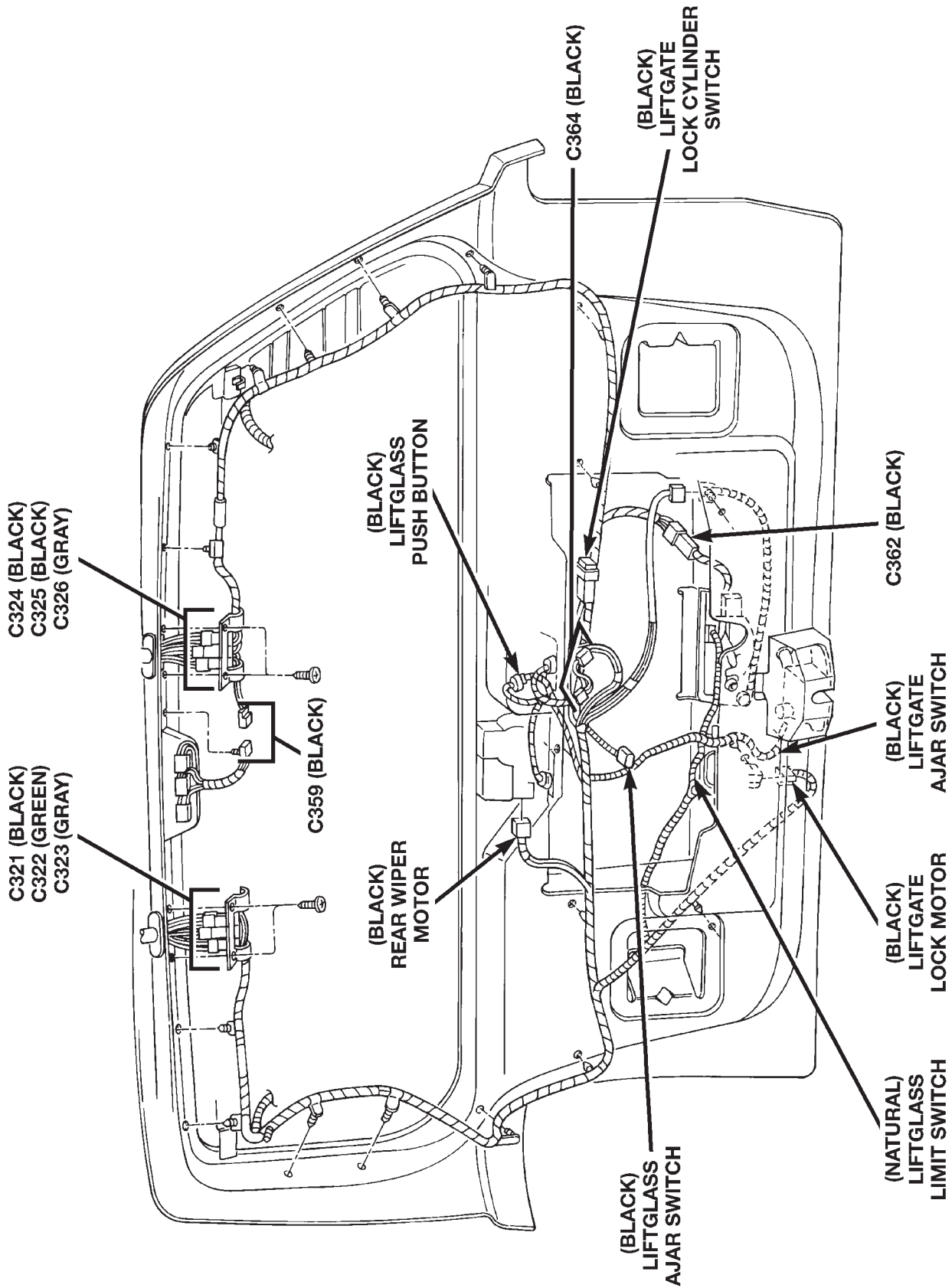


Fig. 20 Liftgate Connectors—RHD

DESCRIPTION AND OPERATION (Continued)

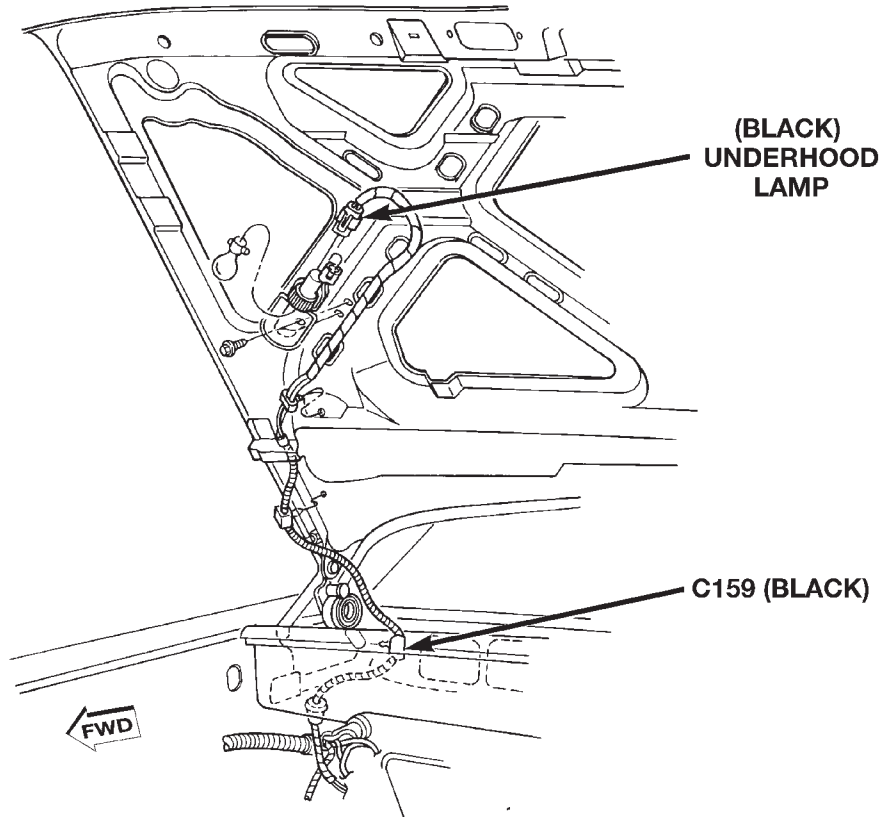


Fig. 21 Underhood Lamp—RHD

80b2b70a

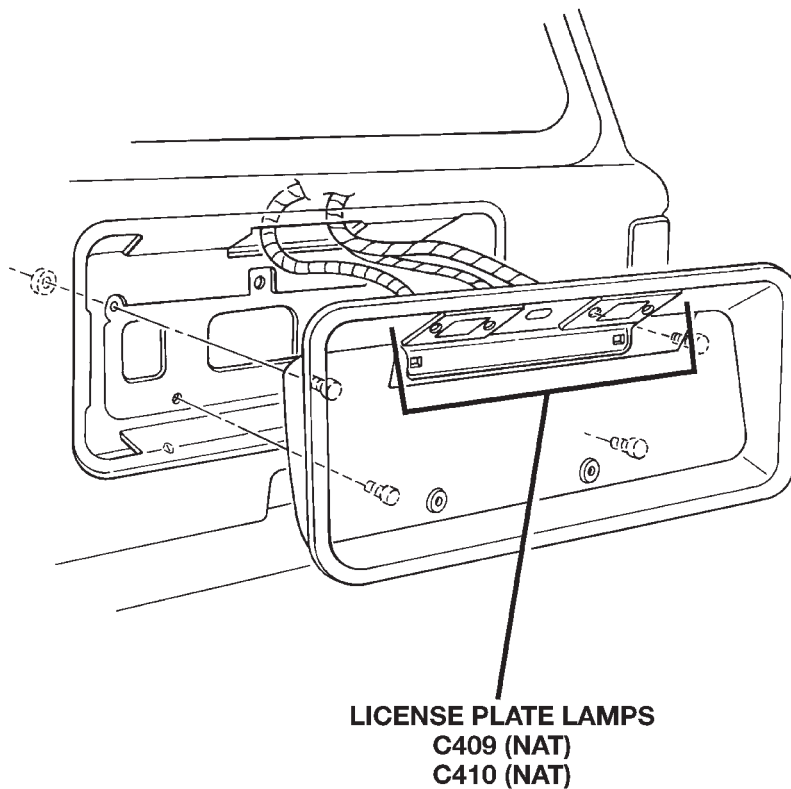


Fig. 22 License Plate Lamps—RHD

80b2b708

8W-95 SPLICE LOCATIONS

DESCRIPTION AND OPERATION

INTRODUCTION

This section provides illustrations identifying the general location of the splices in this vehicle. A splice index is provided. Use the wiring diagrams in each section for splice number identification. Refer to the index for proper splice number.

SPLICE LOCATIONS (LHDO)

For splices that are not shown in the figures in this section a N/S is placed in the Fig. column.

Splice Number	Location	Fig.
S100	In Injector Harness T/O	1
S101	Near Engine Harness T/O	1
S102	Near Battery Temperature Sensor T/O	1
S103	Near Battery Temperature Sensor T/O (4.0L) Near Body Ground (Diesel)	1
S104	Right Front Corner of Engine Compartment	1
S105	Right Front Corner of Engine Compartment	1
S106	Right Front Corner of Engine Compartment	1
S107	Left Front Corner of Engine Compartment	1
S108	Left Front Corner of Engine Compartment	1
S109	Left Front Corner of Engine Compartment	1
S110	Left Side of Engine Compartment	1
S111	Left Side of Engine Compartment	1
S112	Left Side of Engine Compartment	1
S113	Left Side of Engine Compartment	1
S114	Left Side of Engine Compartment	1
S115	Left Rear of Engine Compartment	1
S116	Near Branch to Brake Warning Switch	1
S117	In Branch to Brake Warning Switch	1
S118	In Branch to Brake Warning Switch	1
S119	Left Rear of Engine Compartment	1
S120	Left Rear of Engine Compartment	1

Splice Number	Location	Fig.
S121	Left Rear of Engine Compartment	1
S122	Near PDC T/O	1
S123	Near Vehicle Speed Control Servo T/O	1
S124	Near PDC T/O	1
S125	Near Controller, Antilock Brakes	1
S126	Near A/C High Pressure Switch T/O (4.0L Engine)	1
S126	In Branch to Starter Motor (5.2L Engine)	3
S127	Near Injector No. 3 T/O (4.0L Engine)	2
S128	Near Injector No. 5 T/O (4.0L Engine)	2
S128	Near T/Os for Injectors 6 and 8 (5.2L Engine)	3
S128	Near Coolant Level Sensor	4
S129	Rear of Engine (4.0L Engine)	2
S129	Near Injector No. 3 T/O (5.2L Engine)	3
S130	Rear of Engine (4.0L Engine)	2
S130	Near Camshaft Position Sensor T/O (5.2L Engine)	3
S130	Near Crankshaft Position Sensor (Diesel)	4
S131	Near PCM T/O	2
S131	Right Rear of Engine (5.2L Engine)	3
S132	Near Transmission T/O (4.0L Engine)	2
S132	Rear of Engine (5.2L Engine)	3

DESCRIPTION AND OPERATION (Continued)

Splice Number	Location	Fig.	Splice Number	Location	Fig.
S133	In T/O to Oil Pressure Sensor and Crankshaft Position Sensor (4.0L Engine)	2	S205	Near Branch to Instrument Cluster	4
S133	Near Injector No. 5 T/O (5.2L Engine)	3	S206	Near BCM T/O	4
S134	Near Branch to Powertrain Control Module (4.0L Engine)	2	S207	Near Shift Interlock T/O	4
S134	Rear of Engine (5.2L Engine)	3	S208	Near Branch to Shift Interlock T/O	4
S135	Near Engine Ground T/O (4.0L Engine)	2	S209	Near Body Harness T/O	4
S135	Right Rear of Engine (5.2L Engine)	3	S210	Near Shift Interlock T/O	4
S136	Near Injector No. 7 T/O (5.2L Engine)	3	S211	Near Branch to Graphic Display Module/Vehicle Information Center	4
S137	In Generator T/O	N/S	S212	Near Cigar Lighter/Power Outlet T/O	4
S150	Near G110 T/O	N/S	S214	Near Passenger Airbag T/O	4
S151	In High Speed Cooling Fan T/O	N/S	S215	Near Shift Interlock T/O	4
S152	Near Datalink Connector T/O	N/S	S216	Near Cigar Lighter/Power Outlet T/O	4
S153	Near High Pressure Cut-Out Switch T/O (5.2L/5.9L) Near G110 T/O (4.0L)	N/S	S218	Near Passenger Airbag T/O	4
S154	Near Datalink Connector T/O (5.2L/5.9L) Near G110 T/O (4.0L)	N/S	S219	Near Branch to Graphic Display Module/Vehicle Information Center	4
S170	In PDC T/O	N/S	S220	Near Passenger Airbag T/O	4
S171	Near Crankshaft Position Sensor T/O	4	S221	On HVAC Harness	6
S173	Near Body Ground T/O	1	S222	On HVAC Harness	6
S174	Near PDC T/O	1	S223	On HVAC Harness	6
S175	Near PDC T/O	1	S226	On HVAC Harness	6
S176	Near PDC T/O	1	S300	Near Left Kick Panel	5
S177	Near PDC T/O	1	S301	Near Left Kick Panel	5
S178	Left Side of Engine Compartment	1	S302	Near Left Kick Panel	5
S179	Left Side of Engine Compartment	1	S303	Near T/O to Floor Console	7
S180	Left Rear of Engine Compartment	1	S304	Near Amplifier T/O	7
S181	Near ABS Controller T/O	N/S	S305	Near Branch to Left Rear Door	7
S182	Near ABS Controller T/O	1	S306	Near T/O to Left Rear Door	7
S190	Near Engine Ground T/O	2	S307	Near T/O to Left Rear Door	7
S200	In Body Harness T/O	4	S308	Near T/O to Power Amplifier	7
S201	Near Rear Wiper/washer Switch T/O	4	S309	In T/O to Power Amplifier	7
S202	Near Stop Lamp Switch T/O	4	S310	Near T/O to Power Amplifier	7
S203	Near Stop Lamp Switch T/O	4	S311	Left Rear Quarter Panel	7
S204	Near Branch to Instrument Cluster	4	S312	Left Rear Quarter Panel	7
			S313	Left Rear Quarter Panel	7
			S314	Near Trailer Harness T/O	7
			S315	Top of Left Rear Quarter Panel	7
			S316	Near Right Side T/O for Liftgate	8
			S317	In T/O to Power Amplifier	7
			S318	In Branch to Power Amplifier	7
			S319	Near Branch to Right Rear Door Ajar Switch	8

DESCRIPTION AND OPERATION (Continued)

Splice Number	Location	Fig.
S320	In Branch to Dome/Reading Lamp	10
S321	Between Day/Night Mirror T/O and Right Vanity Mirror T/O	9
S322	Between Day/Night Mirror T/O and Right Vanity Mirror T/O	9
S323	Near Day/Night Mirror T/O	9
S324	In Left Front Door, Between Power Window Motor T/O and Power Mirror T/O	10
S325	In Right Front Door, Near Power Window Motor T/O	10
S326	In Right Front Door, Near Power Window Motor T/O	10
S327	In Right Front Door, Near Power Window Motor T/O	10
S328	In Liftgate, Near Rear Window Defogger T/O	11
S329	In Liftgate, Near Rear Wiper Motor T/O	11
S330	In Factory Trailer Tow Harness, Near Body Harness Connector	7
S331	In Aftermarket Trailer Tow Harness, Near Trailer Receptacle Harness Connector	N/S
S332	In Liftgate, Near Left Body Connectors	11
S333	Near T/O to Right Power Seat	8
S334	In Branch to Dome Reading Lamp	9
S335	In Branch to Power Amplifier	7
S336	In Liftgate, Between Rear Wiper Motor T/O and Liftgate Lock Motor T/O	11
S400	In Left Power Seat Harness, Near Lumbar Motor T/O	N/S
S401	In Left Power Seat Harness, Near Riser Motor Sensor T/O	N/S
S402	In Left Power Seat Harness, Between Riser Motor Sensor T/O and Heated Seat Module T/O	N/S

Splice Number	Location	Fig.
S403	In Left Power Seat Harness, Near Seat Switch T/O	N/S
S404	In Right Power Seat Harness, Near Seat Motor T/Os	N/S
S405	In Right Power Seat Harness, Near Seat Motor T/Os	N/S
S406	In Right Power Seat Harness, In Branch to Seat Switch	N/S
S407	In Left Power Seat Harness, Near Lumbar Motor T/O	N/S
S408	Near Left Front Turn Signal Bulb Socket	N/S
S409	Near Left Front Turn Signal Bulb Socket	N/S
S410	Near Left Front Park Lamp Bulb Socket	N/S
S411	In Left Tail Lamp Harness, Between Body Connector and Grommet	N/S
S412	In Left Tail Lamp Harness, Between Body Connector and Grommet	N/S
S413	Near Right Front Turn Signal Bulb Socket	N/S
S414	Near Left Front Turn Signal Bulb Socket	N/S
S415	Near Right Front Park Lamp Bulb Socket	N/S
S416	In Left Tail Lamp Harness, Between Body Connector and Grommet	N/S
S417	In Right Tail Lamp Harness, Between Body Connector and Grommet	N/S
S418	In License Plate Lamp Harness	11
S419	In License Plate Lamp Harness	11

DESCRIPTION AND OPERATION (Continued)

80b3c92e

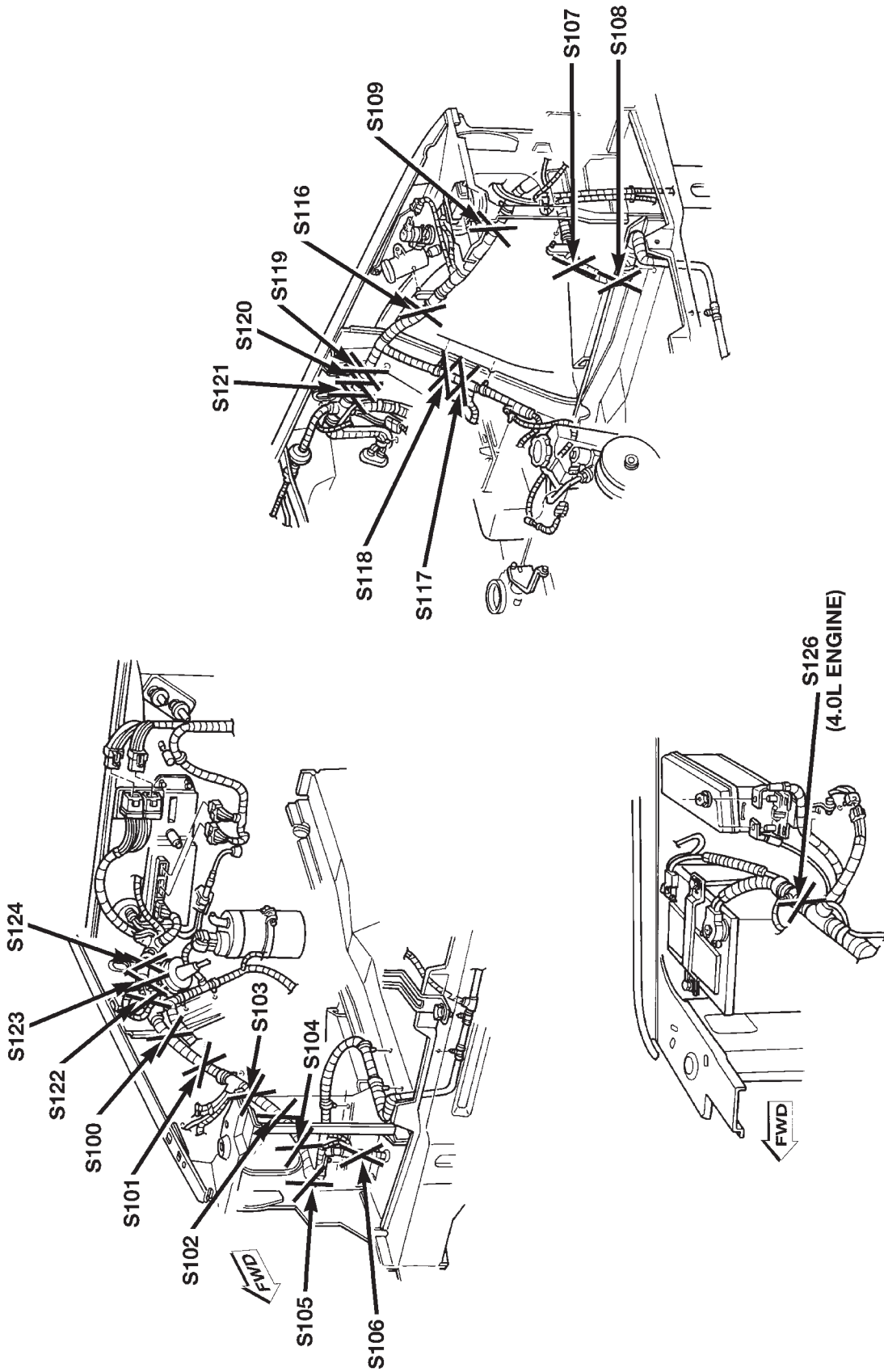


Fig. 1 Engine Compartment Splices—LHD

DESCRIPTION AND OPERATION (Continued)

80b3c92f

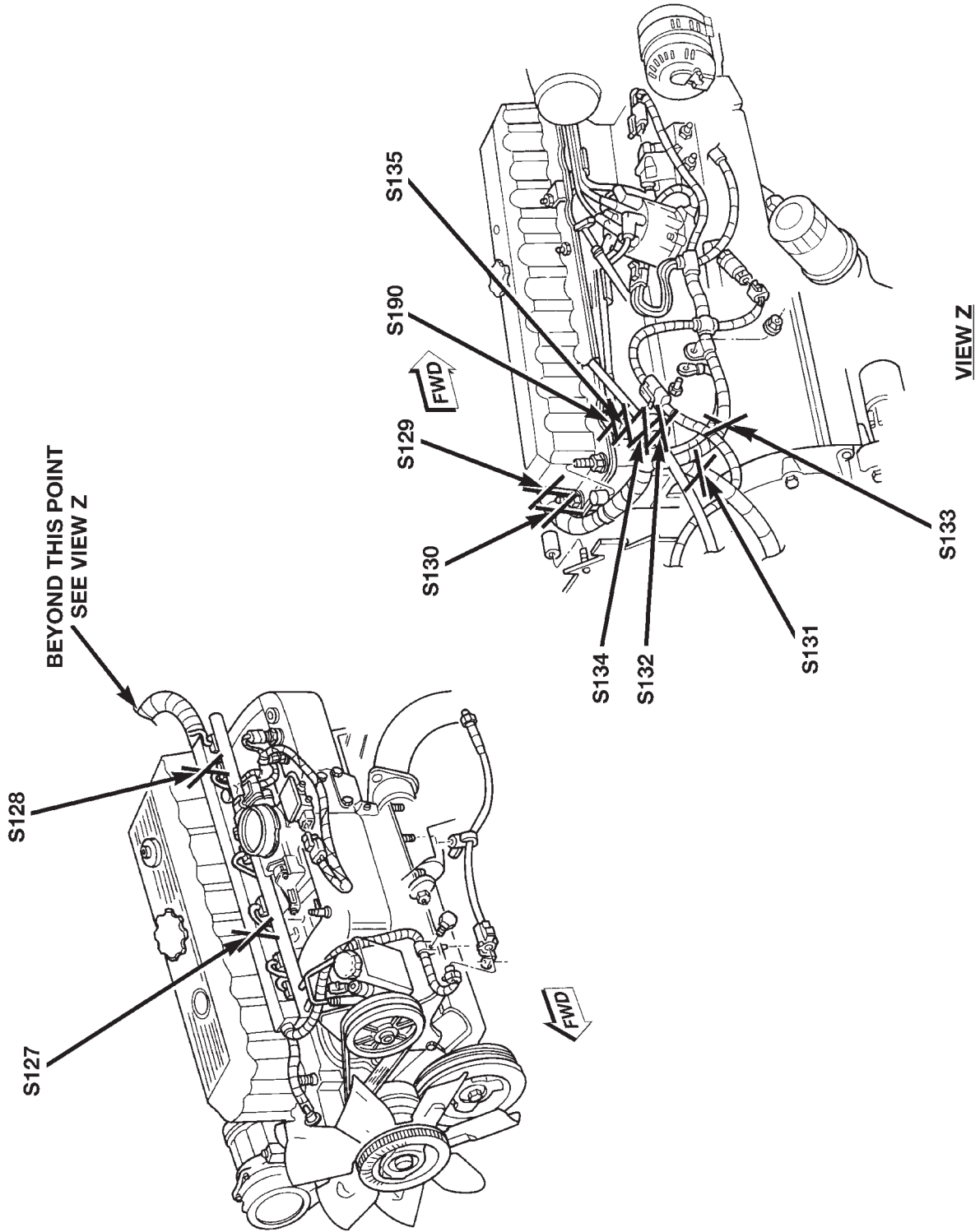


Fig. 2 Engine Wiring Splices — 4.0L Engine, LHD

DESCRIPTION AND OPERATION (Continued)

8053C930

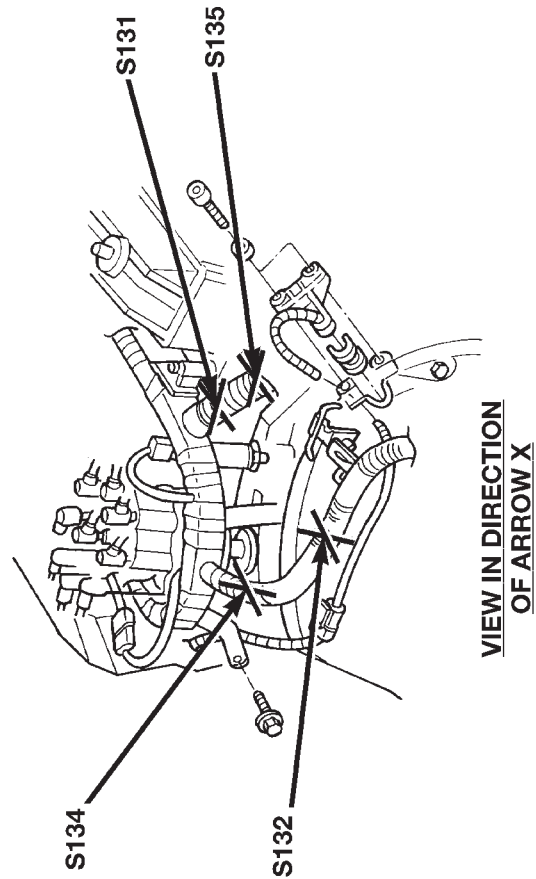
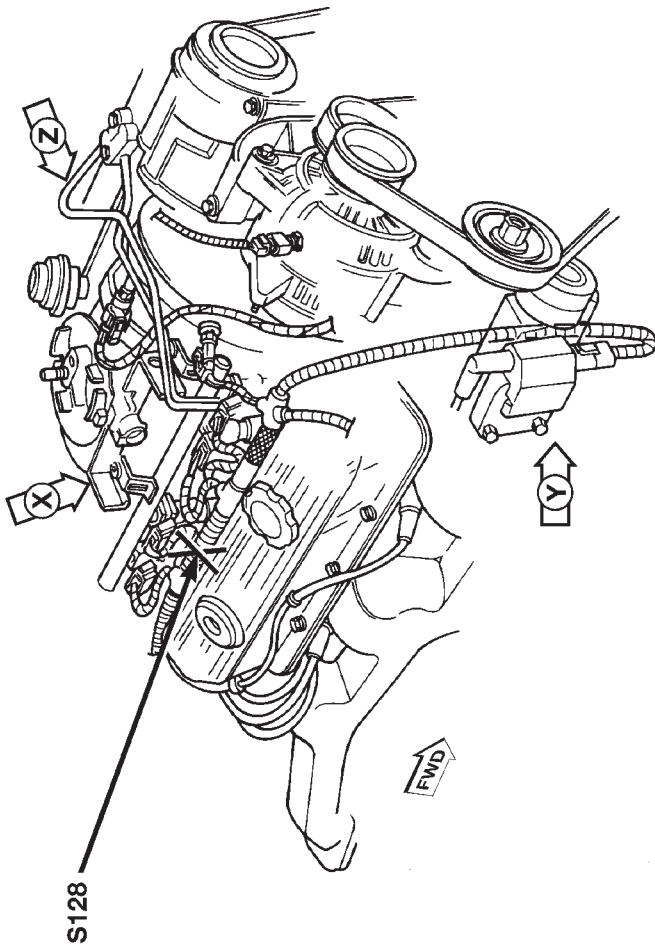
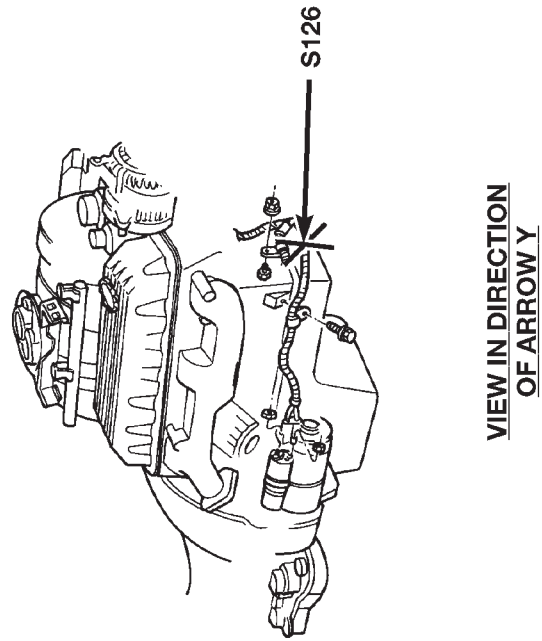
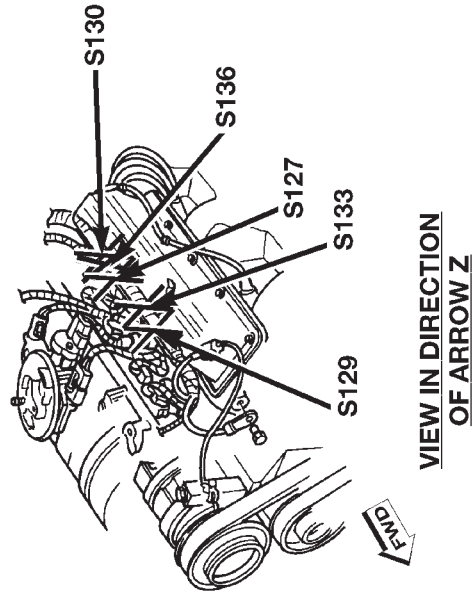


Fig. 3 Engine Wiring Splices—5.2L Engine, LHD

DESCRIPTION AND OPERATION (Continued)

80b3c931

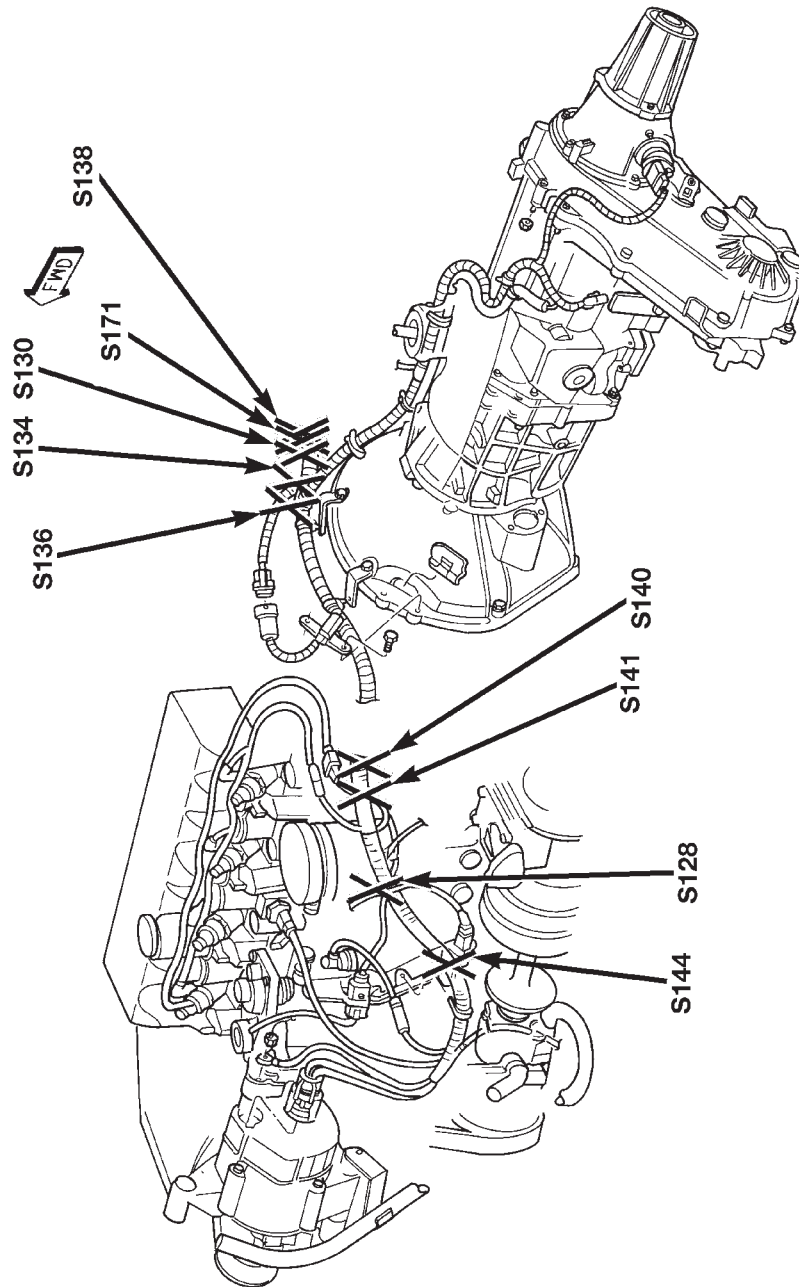


Fig. 4 Engine and Transmission Wiring Splices — Diesel, LHD

DESCRIPTION AND OPERATION (Continued)

80b3c932

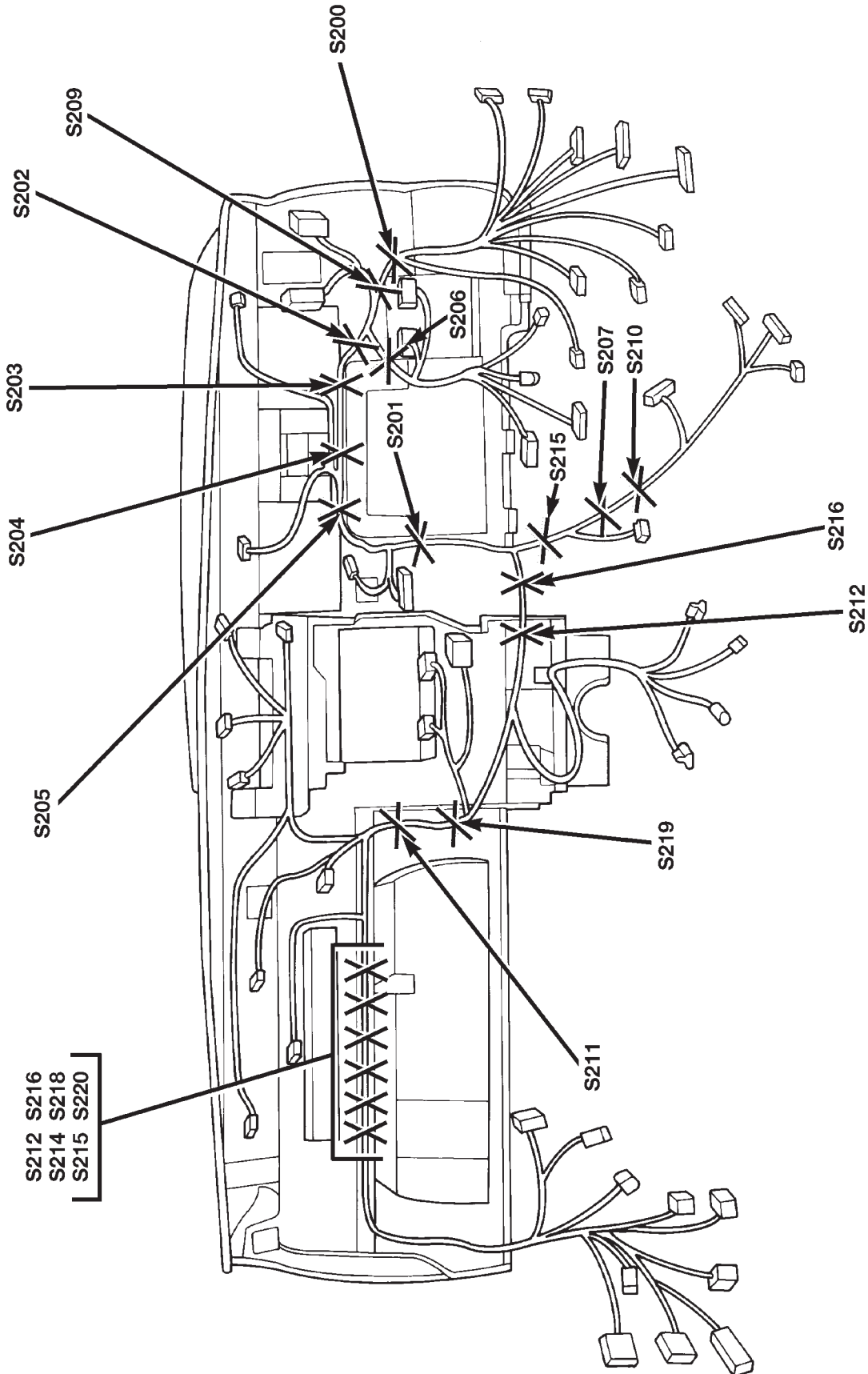


Fig. 5 Instrument Panel Splices—LHD

DESCRIPTION AND OPERATION (Continued)

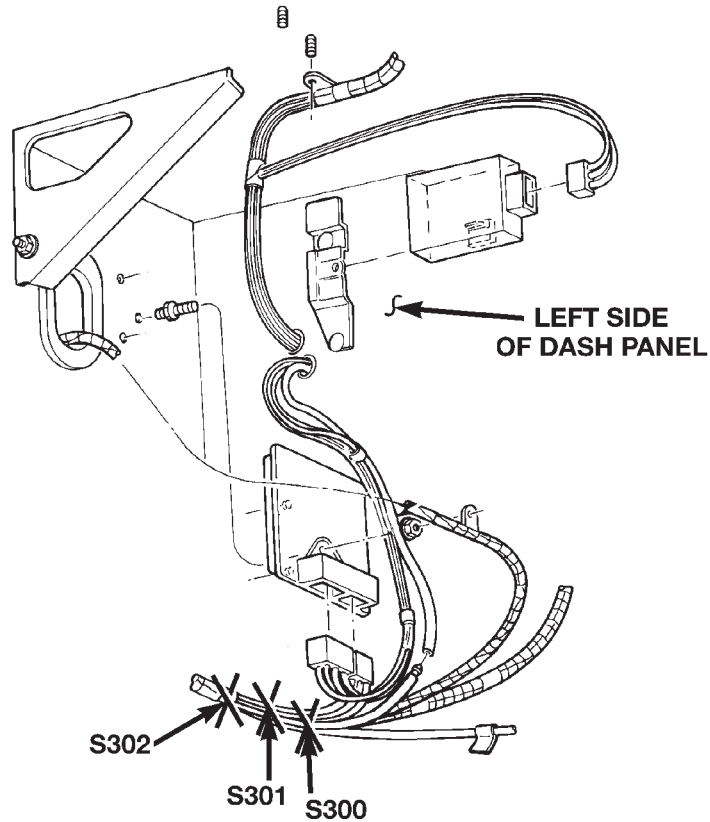


Fig. 6 Body Splices—LHD

80b2b70c

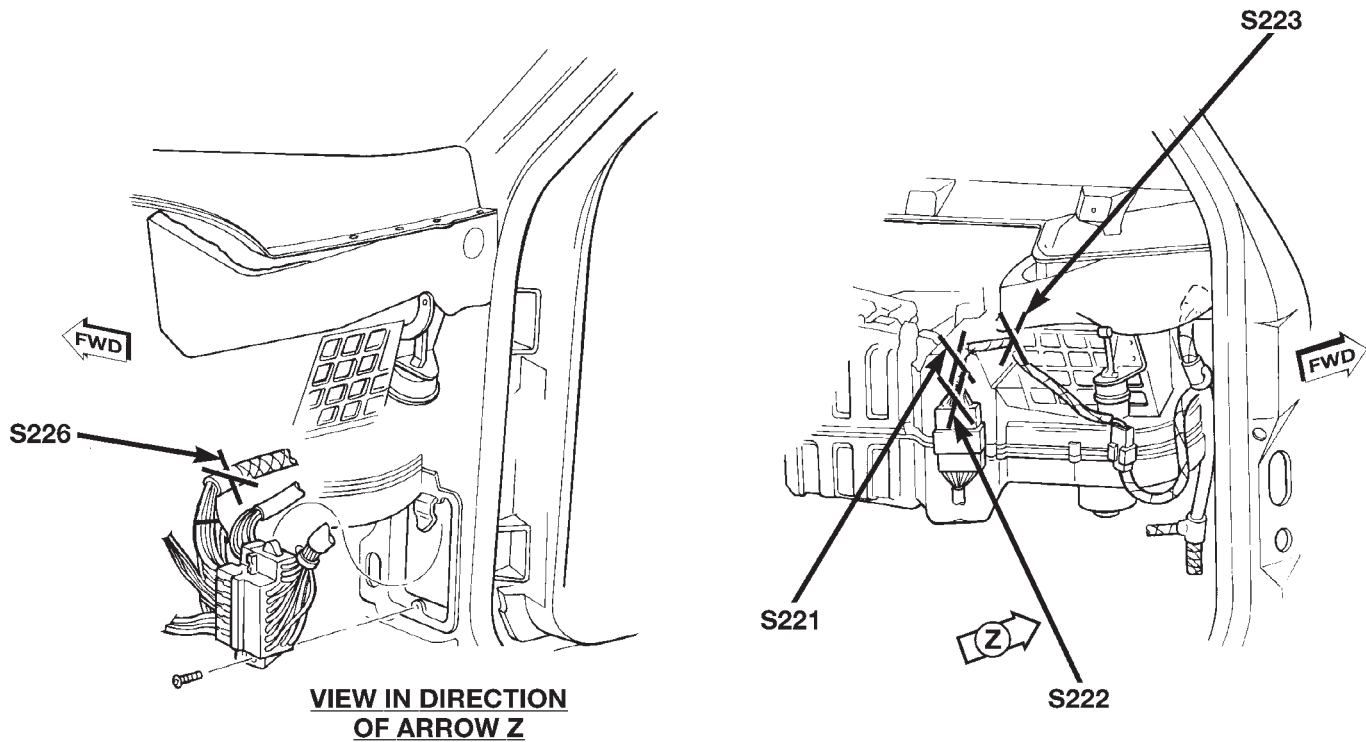
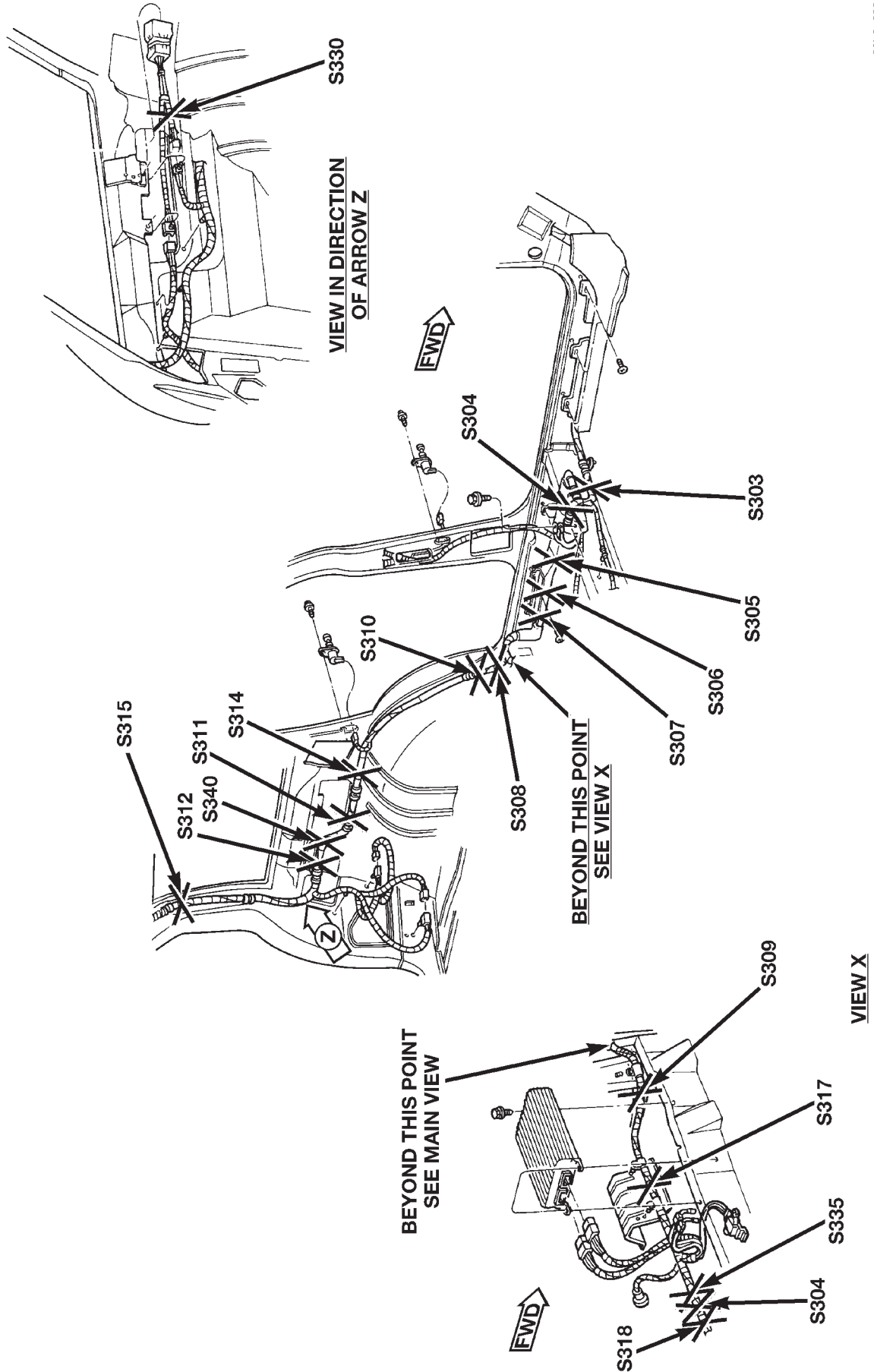


Fig. 7 HVAC Harness Splices—LHD

80b2b70d

DESCRIPTION AND OPERATION (Continued)



80b3c933

Fig. 8 Left Body Side Wiring Splices—LHD

DESCRIPTION AND OPERATION (Continued)

805fe520

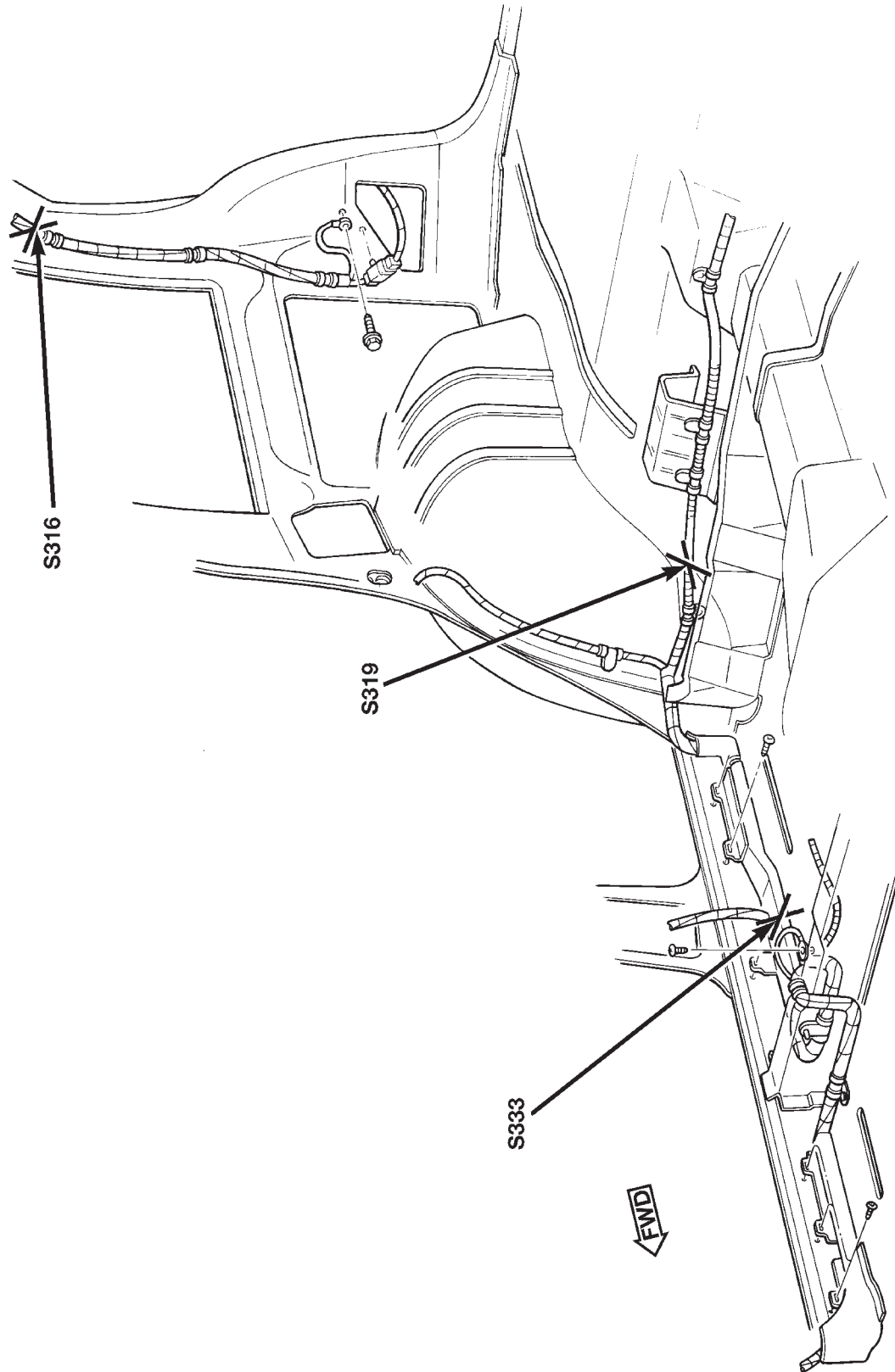


Fig. 9 Right Side Body Wiring Splices—LHD

DESCRIPTION AND OPERATION (Continued)

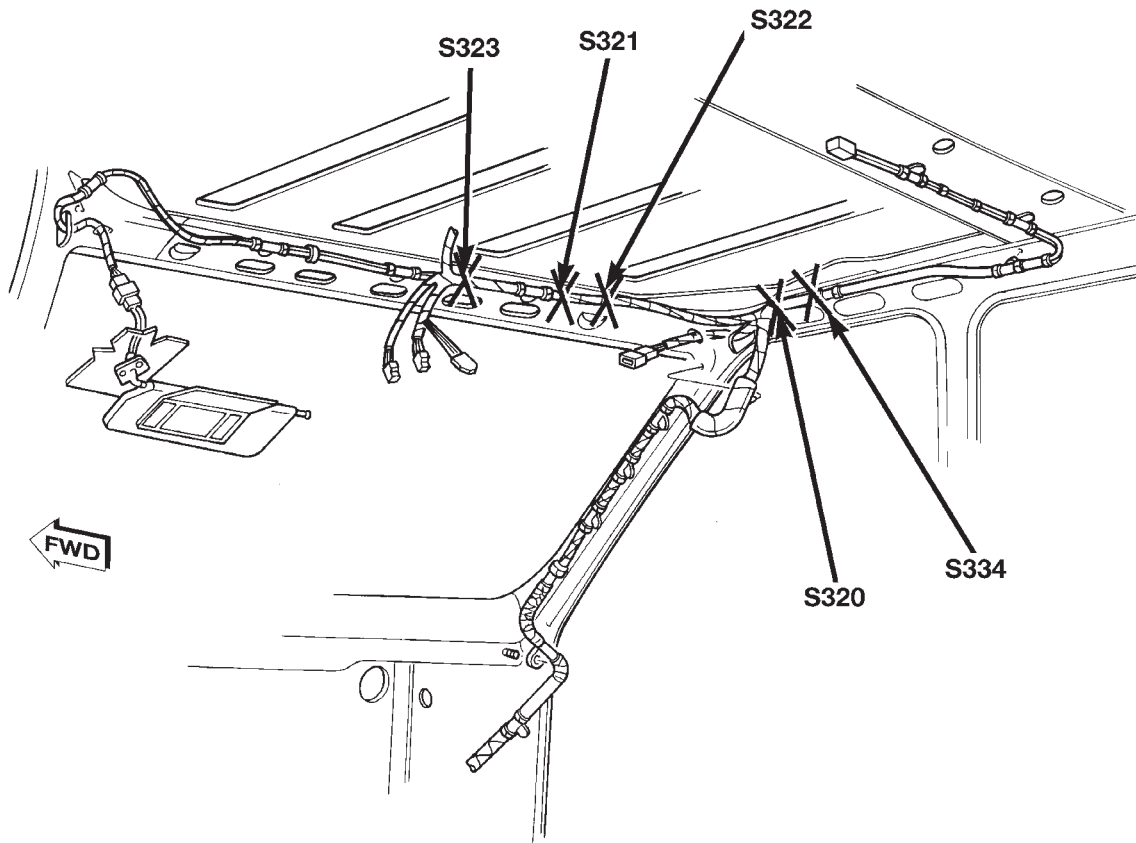


Fig. 10 Roof Wiring Splices—LHD

80500593

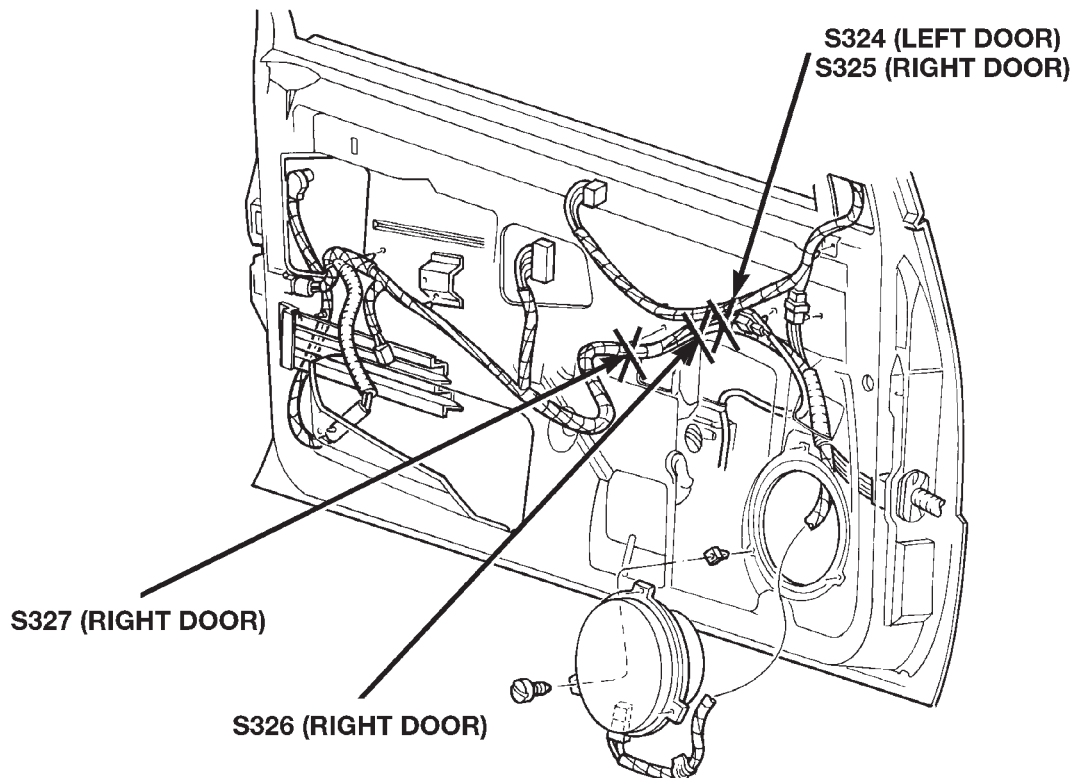


Fig. 11 Front Door Harness Splices—LHD

80a01407

DESCRIPTION AND OPERATION (Continued)

80516501

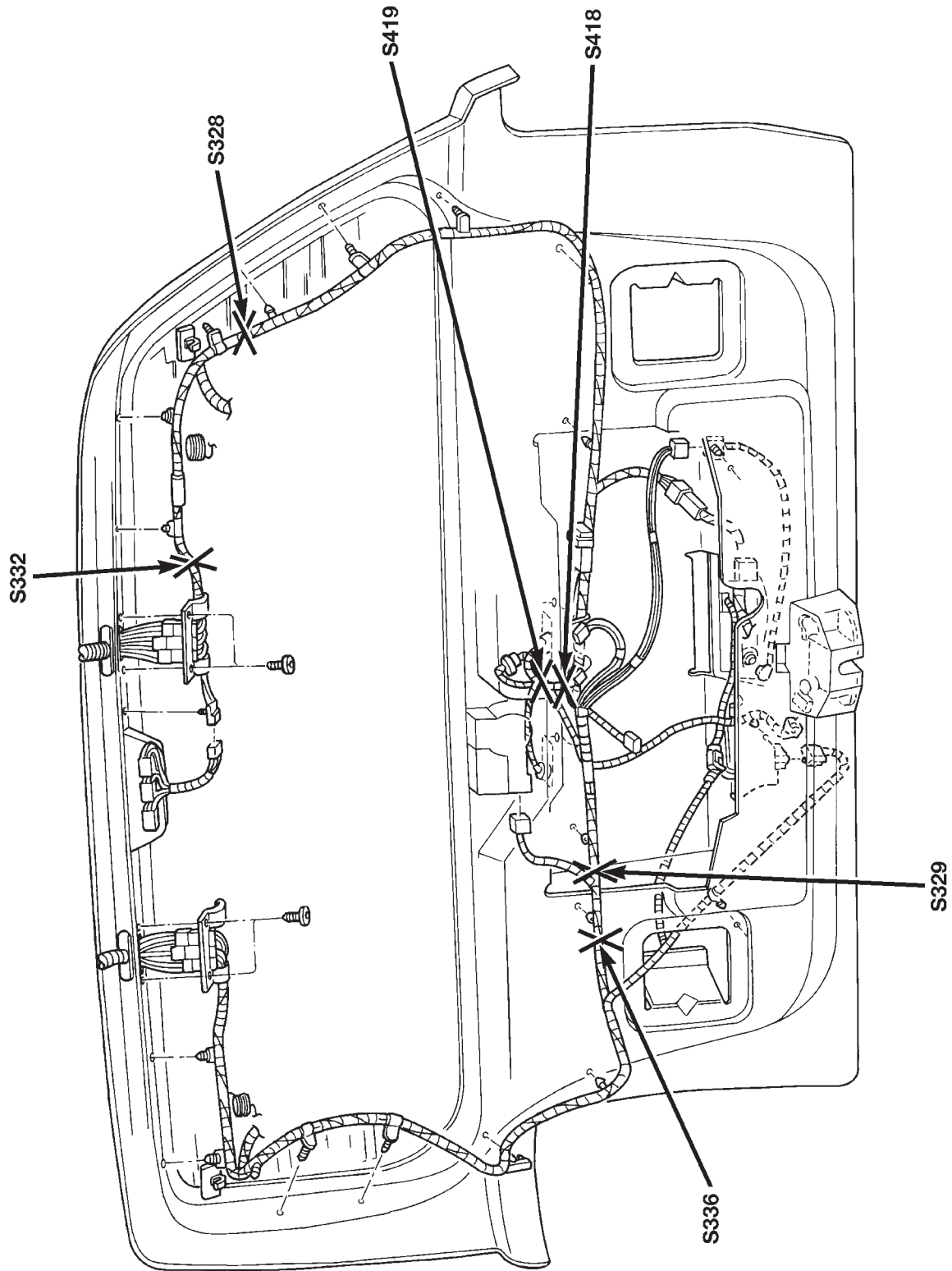


Fig. 12 Liftgate Splices — LHD

DESCRIPTION AND OPERATION (Continued)**SPLICE LOCATIONS (RHD)**

For splices that are not shown in the figures in this section an N/S is placed in the Fig. column.

Splice Number	Location	Fig.
S100	Near Power Distribution Center	1
S101	Near Engine Harness T/O	1
S102	Near Battery Temperature Sensor T/O	1
S103	Near Battery Temperature Sensor T/O (4.0L) Near Body Ground (Diesel)	1
S104	Right Front Corner of Engine Compartment	1
S105	Right Front Corner of Engine Compartment	1
S106	Right Front Corner of Engine Compartment	1
S107	Left Front Corner of Engine Compartment	1
S108	Left Front Corner of Engine Compartment	1
S109	Near A/C Low Pressure T/O	1
S110	Near ABS Controller T/O	1
S111	Near ABS Controller T/O	1
S112	Near ABS Controller T/O	1
S113	Near ABS Controller T/O	1
S114	Near ABS Controller T/O	1
S115	Near ABS Controller T/O	1
S119	Near Low Washer Fluid Level Sensor T/O	1
S120	Near T/O to Low Washer Fluid Level Sensor	1
S121	Near T/O to Low Washer Fluid Level Sensor	1
S122	Near Vehicle Speed Control Servo T/O (4.0L) Near Washer Reservoir (Diesel)	1
S124	Near Washer Reservoir	1
S125	Near Controller, Antilock Brakes	5
S126	Near PDC T/O	3
S127	Near Injector No. 3 T/O (4.0L Engine)	2
S128	Near T/Os for A/C Compressor	4
S129	Rear of Engine (4.0L Engine)	2

Splice Number	Location	Fig.
S129	Rear of Engine (Diesel Engine)	4
S130	Rear of Engine (4.0L Engine)	2
S130	Near Crankshaft Position Sensor T/O (Diesel Engine)	3
S131	In Branch to PCM(4.0L Engine)	2
S132	Near Branch to Transmission (4.0L Engine)	2
S133	In Branch to Oil Pressure Sensor and Crankshaft Position Sensor (4.0L Engine)	2
S134	Near Branch to Powertrain Control Module (4.0L Engine)	2
S134	Near Crankshaft Position Sensor T/O (Diesel Engine)	3
S135	Near Branch to PCM (4.0L Engine)	2
S136	Near Crankshaft Position Sensor T/O (Diesel Engine)	3
S137	Near PDC	N/S
S138	Near Crankshaft Position Sensor T/O (Diesel Engine)	3
S140	Rear of Engine (Diesel Engine)	3
S141	Rear of Engine (Diesel Engine)	3
S142	Rear of Engine(Diesel)	N/S
S150	Near G110 T/O	N/S
S152	Near Data Link Connector T/O	N/S
S153	Near G110 T/O	N/S
S154	Near G110 T/O	N/S
S171	Near Crankshaft Position Sensor	3
S173	Near Body Grounds G106 and G107	1
S174	Near Body Grounds G106 and G107	1
S175	Near Engine Harness T/O	1
S176	Near Engine Harness T/O	1
S177	Near Engine Harness T/O	1
S178	Near ABS Controller T/O	1
S179	Near ABS Controller T/O	1
S180	Left Rear of Engine Compartment	N/S

DESCRIPTION AND OPERATION (Continued)

Splice Number	Location	Fig.
S181	Near ABS Controller T/O	1
S182	Near Engine Harness T/O	1
S183	Near G110 T/O	N/S
S201	Near Headlamp Switch T/O	4
S202	Near Stop Lamp Switch T/O	4
S203	Near Stop Lamp Switch T/O	4
S204	Near Branch to Instrument Cluster	4
S205	Near Branch to Instrument Cluster	4
S206	Near Branch to Rear Window Defogger Switch	4
S207	Near Shift Interlock T/O	4
S209	Near Branch to Shift Interlock T/O	4
S210	Near Transfer Case Illumination Lamp T/O	4
S211	Near Branch to Graphic Display Module/Vehicle Information Center	4
S212	Near Stoplamp T/O	4
S214	Near Passenger Airbag T/O	4
S215	Left Side of Steering Column	4
S216	Near Passenger Airbag T/O	4
S218	Near Passenger Airbag T/O	4
S219	Near Branch to Graphic Display Module/Vehicle Information Center	4
S220	Near Passenger Airbag T/O	4
S221	On HVAC Harness	6
S222	On HVAC Harness	6
S223	On HVAC Harness	6
S226	On HVAC Harness	6
S300	Near Left Kick Panel	5
S301	Near Left Kick Panel	5
S302	Near Left Kick Panel	5
S303	Near Branch to Floor Console	7
S304	Near Power Amp T/O	8
S305	Near Branch to Left Rear Door	7
S306	Near Branch to Left Rear Door	7
S307	Near Branch to Left Rear Door	7
S308	Near Branch to Power Amplifier	7
S309	In Branch to Power Amplifier	7
S310	Near Branch to Power Amplifier	7
S311	Left Rear Quarter Panel	7
S312	Left Rear Quarter Panel	7
S314	Top of Left Rear Quarter Panel	7

Splice Number	Location	Fig.
S315	Top of Left Rear Quarter Panel	7
S316	Near Right Side T/O for Liftgate	8
S317	In Branch to Power Amplifier	7
S318	In Branch to Power Amplifier	7
S319	Near Branch to Right Rear Door Ajar Switch	8
S320	In Branch to Dome/Reading Lamp	9
S321	Between Day/Night Mirror T/O and Right Vanity Mirror T/O	9
S322	Between Day/Night Mirror T/O and Right Vanity Mirror T/O	9
S323	Near Day/Night Mirror T/O	9
S324	In Left Front Door, Between Power Window Motor T/O and Power Mirror T/O	10
S325	In Right Front Door, Near Power Window Motor T/O	10
S326	In Right Front Door, Near Power Window Motor T/O	10
S327	In Right Front Door, Near Power Window Motor T/O	10
S328	In Liftgate, Near Rear Window Defogger T/O	11
S329	In Liftgate, Near Rear Wiper Motor T/O	11
S330	In Factory Trailer Tow Harness, Near Body Harness Connector	7
S331	In Aftermarket Trailer Tow Harness	N/S
S332	In Liftgate, Near Left Body Connectors	11
S333	Near T/O to Right Power Seat	8
S334	In Branch to Dome Reading Lamp	9
S335	In Branch to Power Amplifier	7
S336	In Liftgate, Between Rear Wiper Motor T/O and Liftgate Lock Motor T/O	11
S340	In Aftermarket Trailer Tow Harness	N/S
S341	Near Body Harness Connector	N/S
S342	Near Body Harness Connector	N/S
S343	Near Body Harness Connector	N/S
S400	In Right Power Seat Harness, Near Lumbar Motor T/O	N/S
S401	In Right Power Seat Harness, Near Riser Motor Sensor T/O	N/S

DESCRIPTION AND OPERATION (Continued)

Splice Number	Location	Fig.
S402	In Right Power Seat Harness, Between Riser Motor Sensor T/O and Heated Seat Module T/O	N/S
S403	In Right Power Seat Harness, Near Seat Switch T/O	N/S
S404	In Left Power Seat Harness, Near Seat Motor T/Os	N/S
S405	In Left Power Seat Harness, Near Seat Motor T/Os	N/S
S406	In Left Power Seat Harness, In Branch to Seat Switch	N/S
S407	In Right Power Seat Harness, Near Lumbar Motor T/O	N/S
S414	Near Left Front Turn Signal Bulb Socket	N/S
S415	Near Right Front Park Lamp Bulb Socket	N/S

Splice Number	Location	Fig.
S416	In Left Tail Lamp Harness, Between Body Connector and Grommet	N/S
S417	In Right Tail Lamp Harness, Between Body Connector and Grommet	N/S
S418	In License Plate Lamp Harness	11
S419	In License Lamp Harness	11
S421	Fuse Link at PDC	N/S
S430	Behind Drivers Airbag	N/S
S431	Behind Drivers Airbag	N/S
S432	Behind Drivers Airbag	N/S
S433	Behind Drivers Airbag	N/S

DESCRIPTION AND OPERATION (Continued)

80b3c328

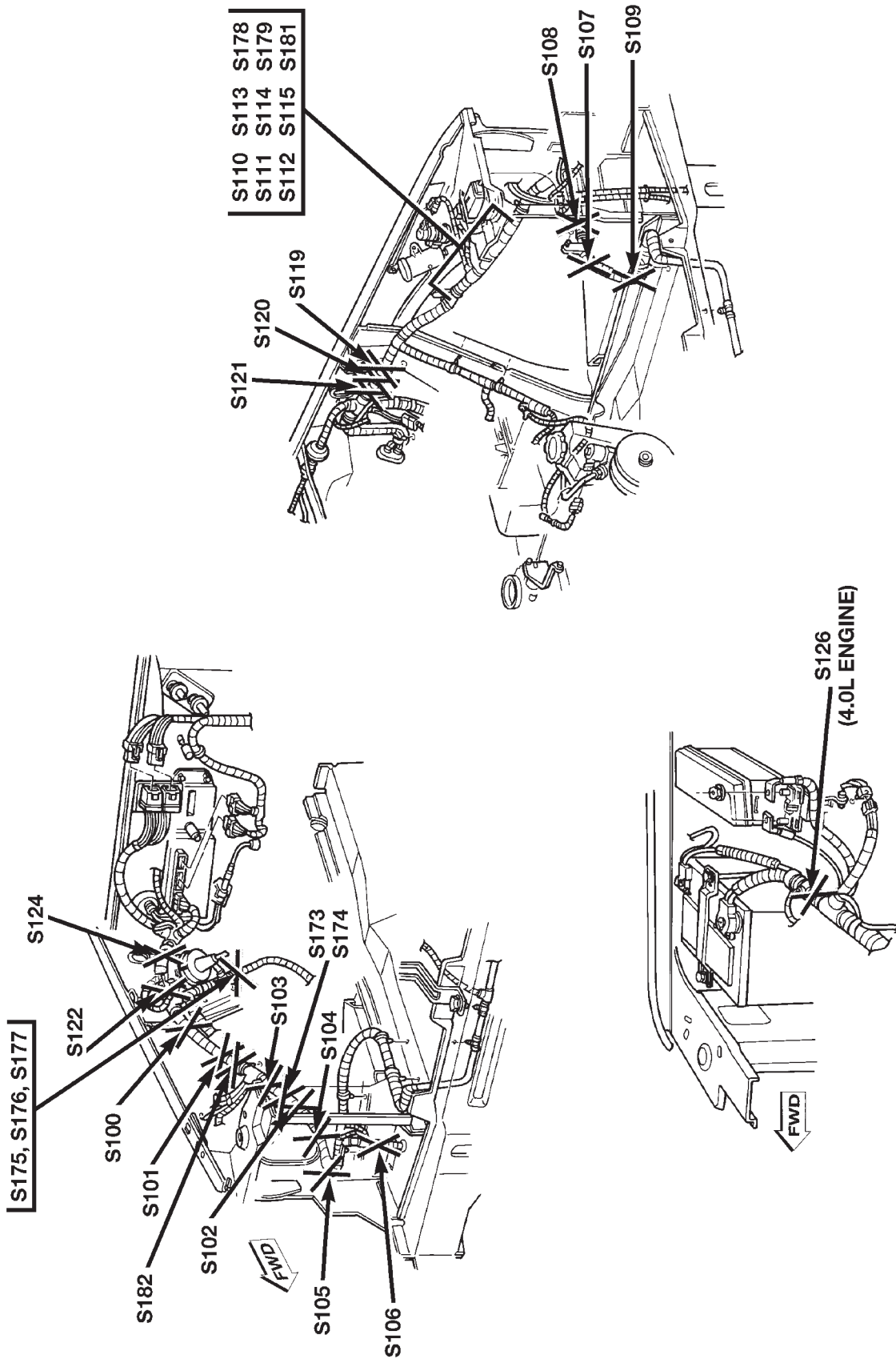


Fig. 1 Engine Compartment Splices — RHD

DESCRIPTION AND OPERATION (Continued)

80036929

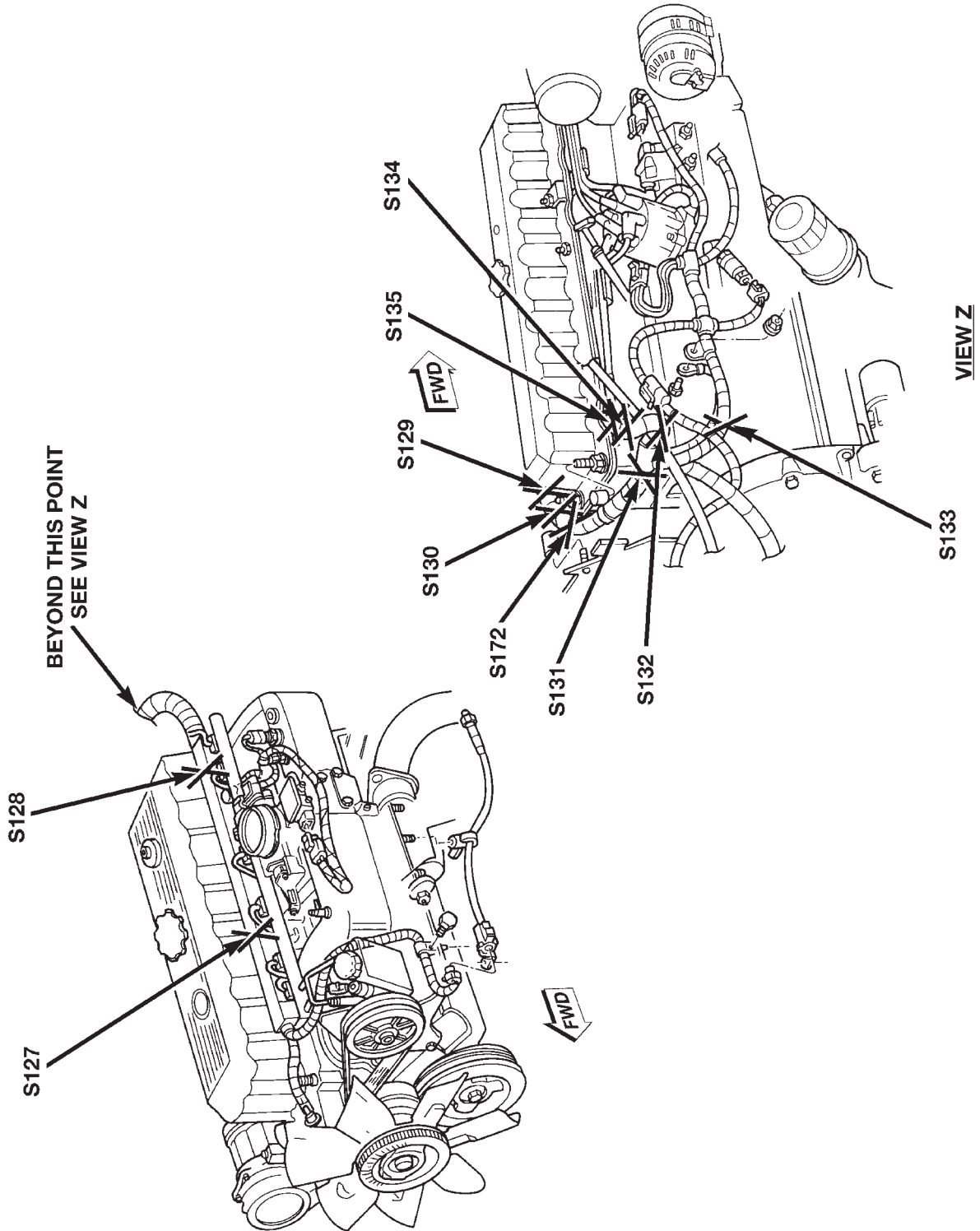


Fig. 2 Engine Wiring Splices — 4.0L Engine, RHD

DESCRIPTION AND OPERATION (Continued)

80b3c92a

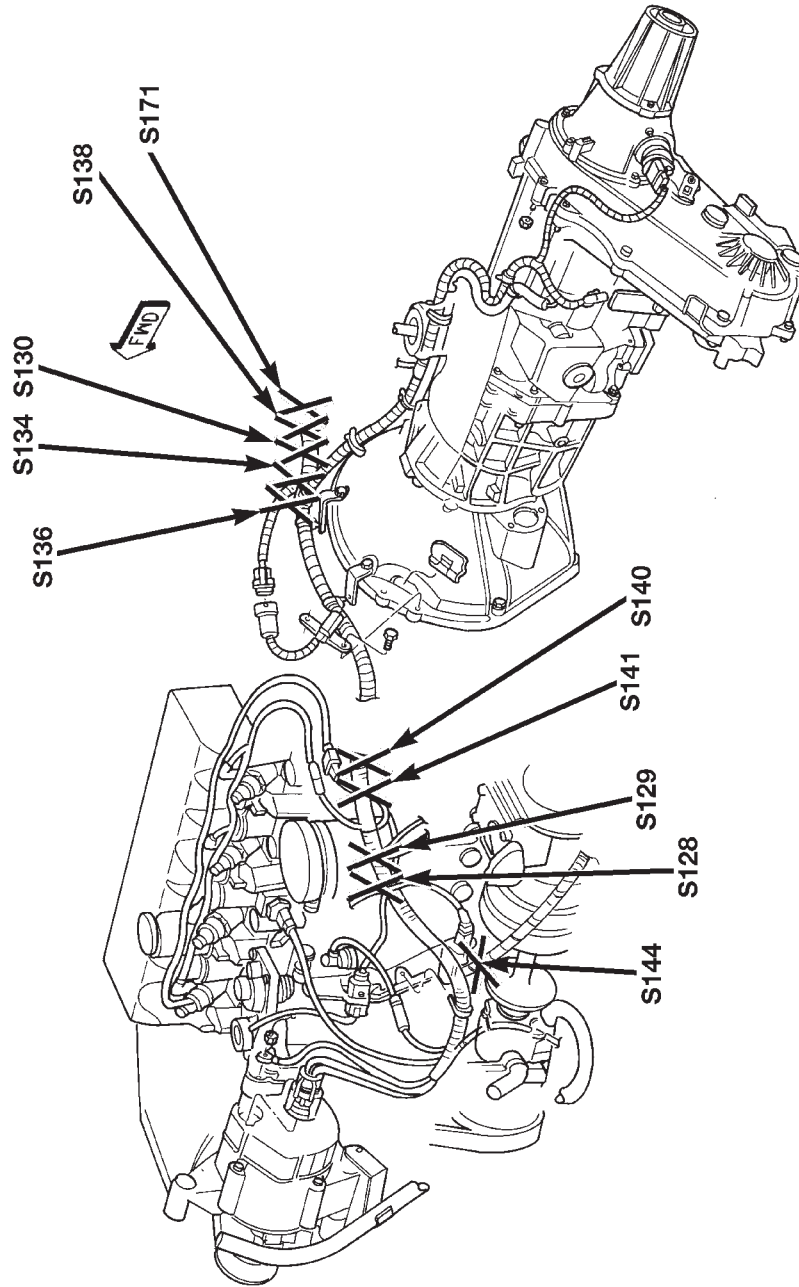
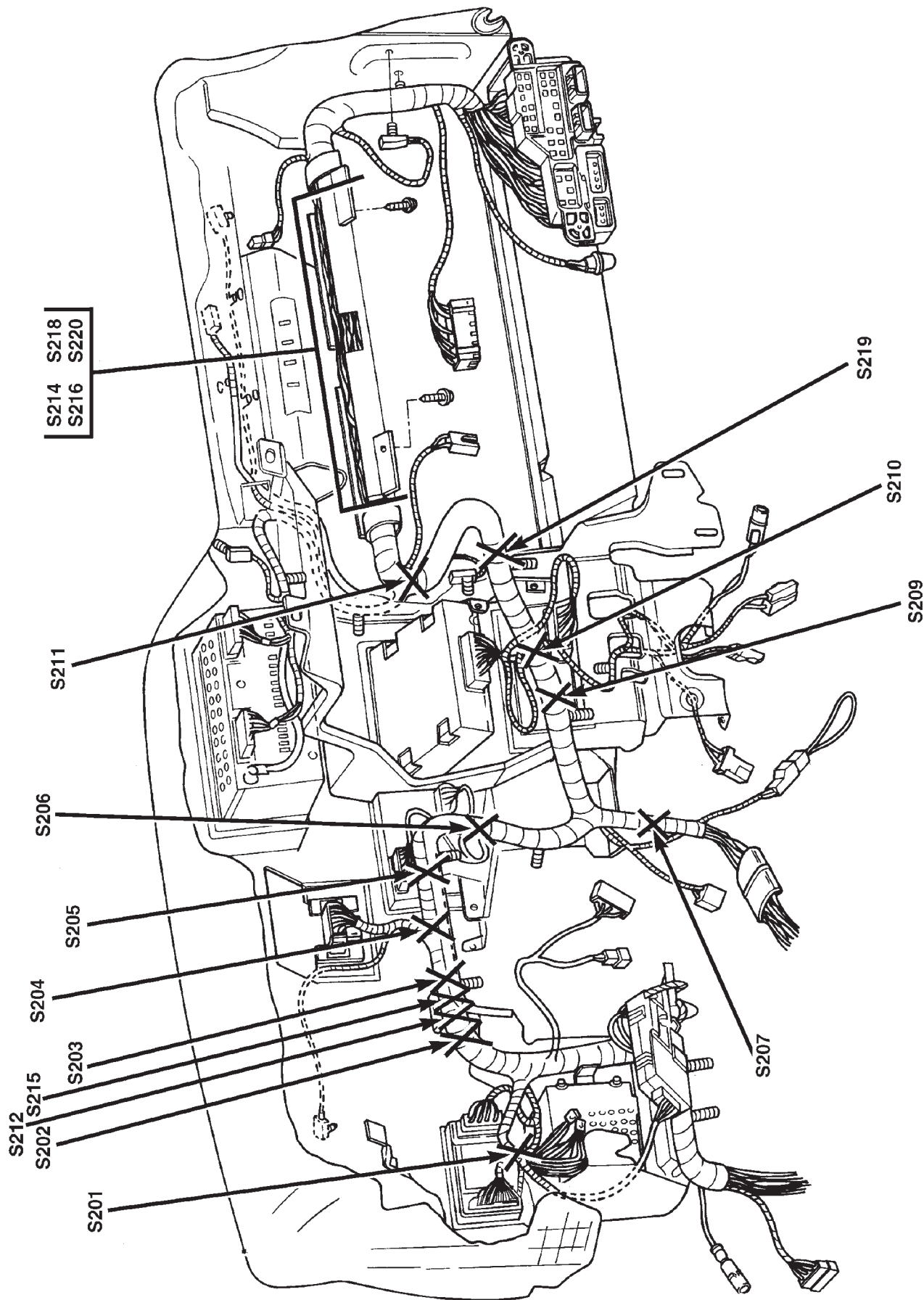


Fig. 3 Engine and Transmission Wiring Splices—Diesel Engine, RHD

DESCRIPTION AND OPERATION (Continued)



80b3c92b

Fig. 4 Instrument Panel Splices—RHD

DESCRIPTION AND OPERATION (Continued)

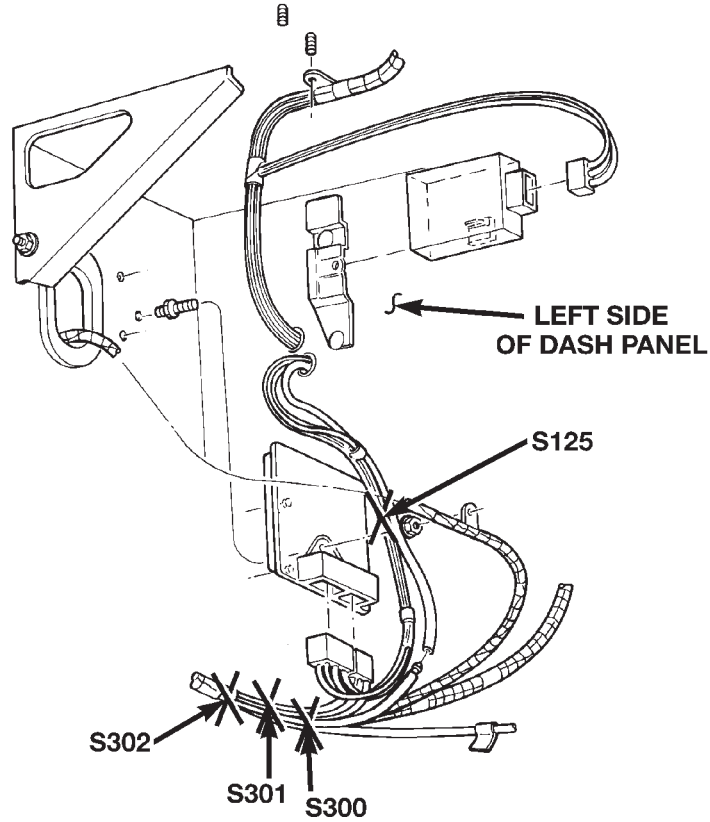


Fig. 5 Body Splices—RHD

8050058f

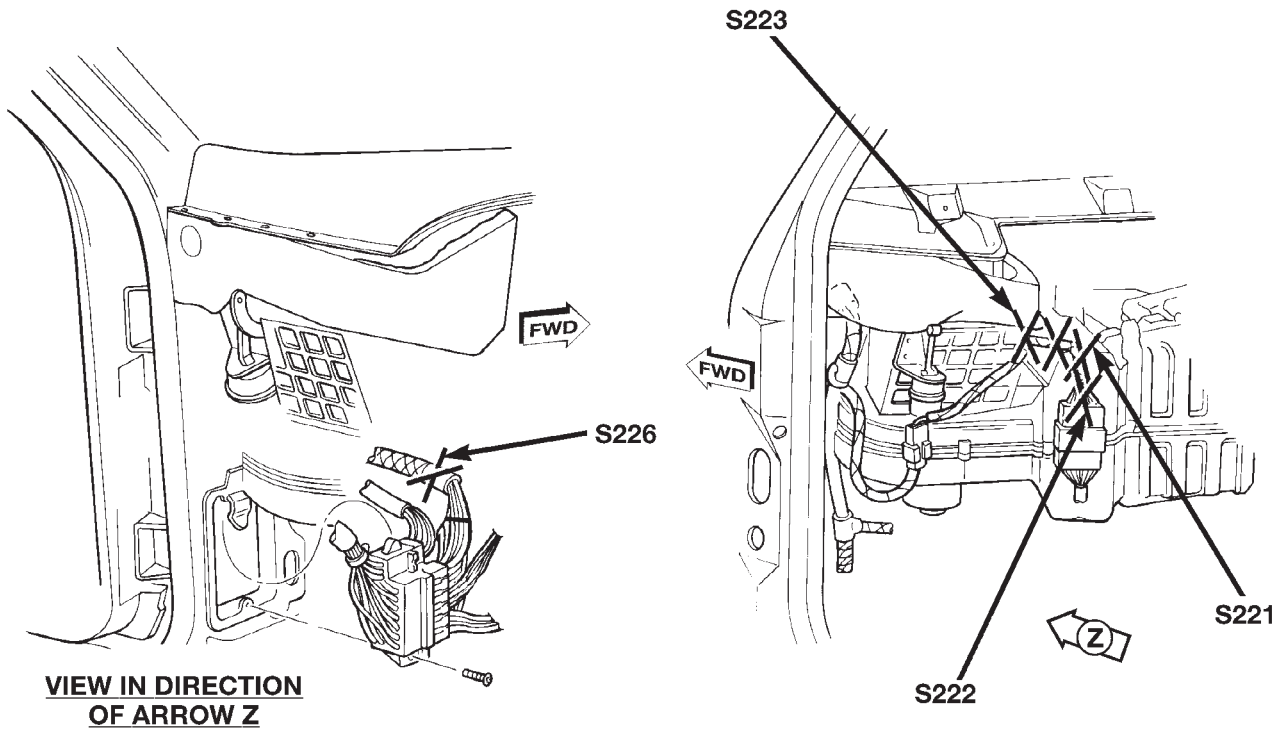
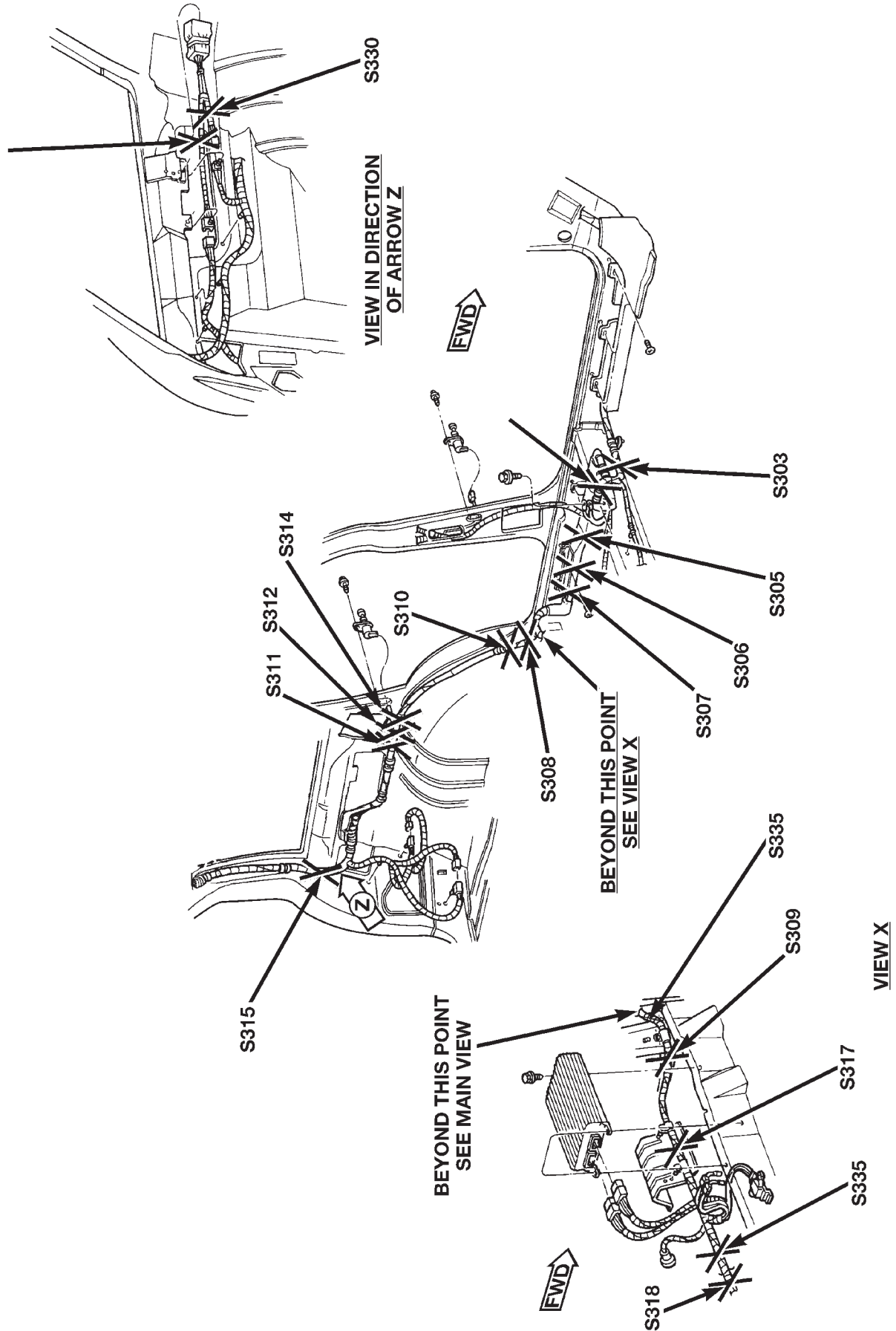


Fig. 6 HVAC Harness Splices—RHD

80b2b70b

DESCRIPTION AND OPERATION (Continued)



80b3c92c

Fig. 7 Left Body Side Wiring Splices—RHD

DESCRIPTION AND OPERATION (Continued)

80b3c92d

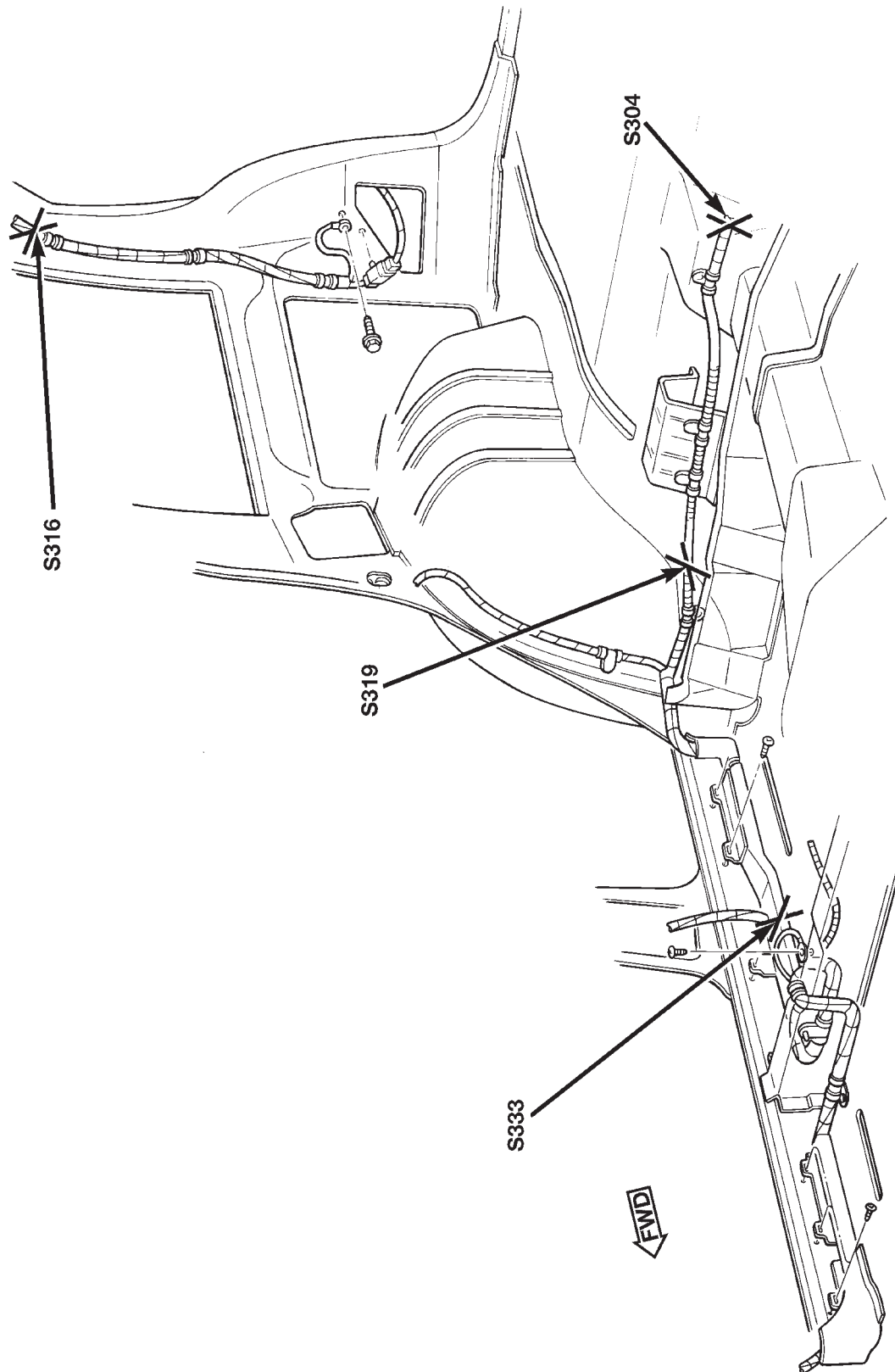


Fig. 8 Right Side Body Wiring Splices — RHD

DESCRIPTION AND OPERATION (Continued)

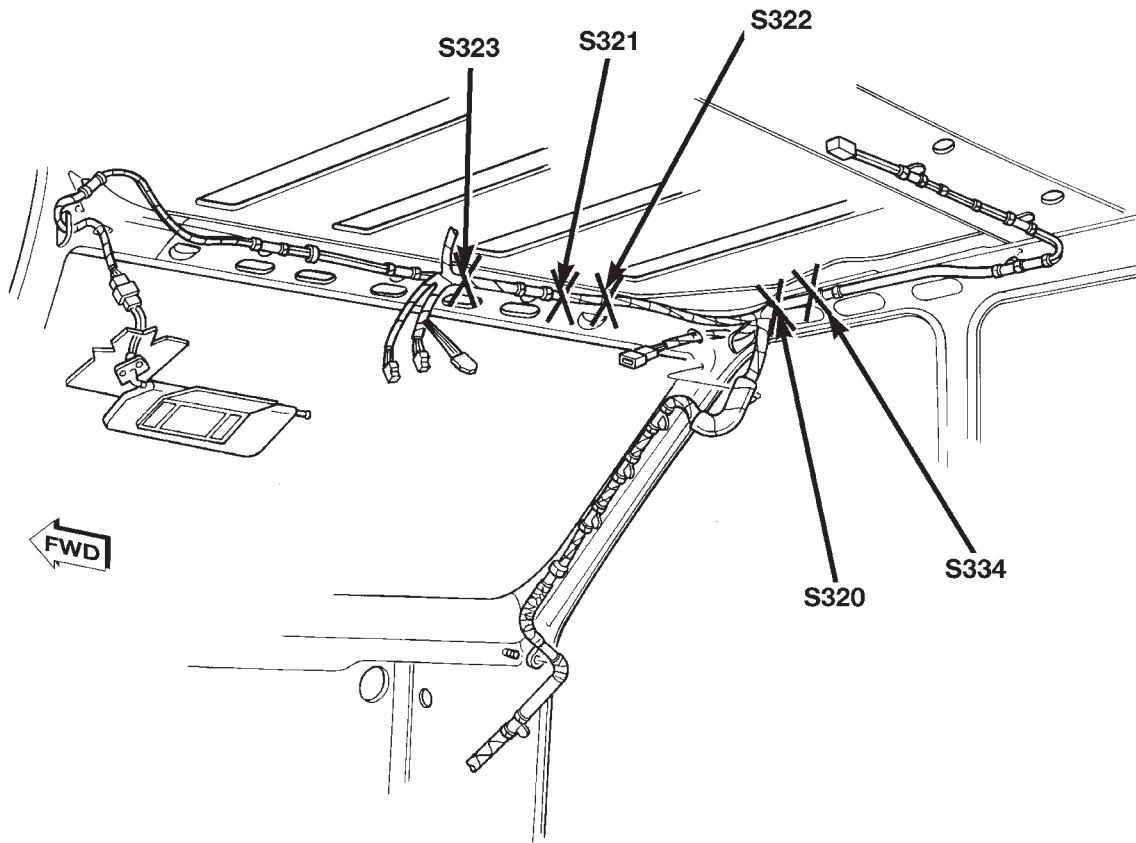


Fig. 9 Roof Wiring Splices—RHD

80500593

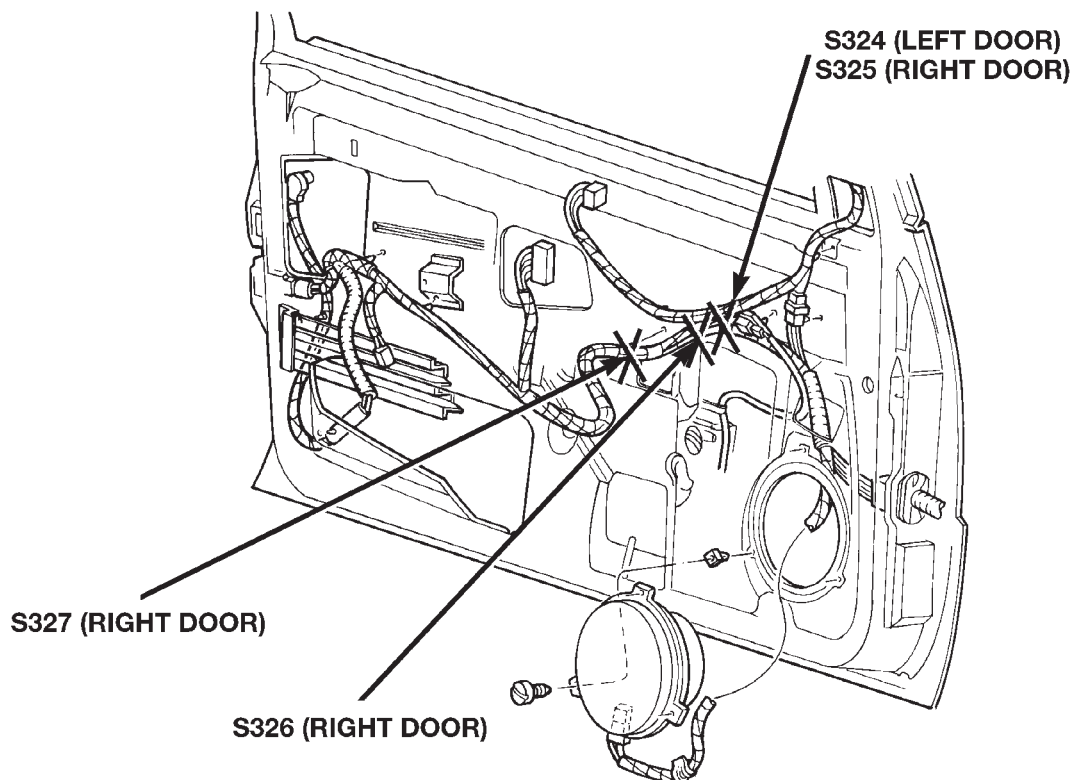


Fig. 10 Front Door Harness Splices—RHD

80a01407

DESCRIPTION AND OPERATION (Continued)

805650F

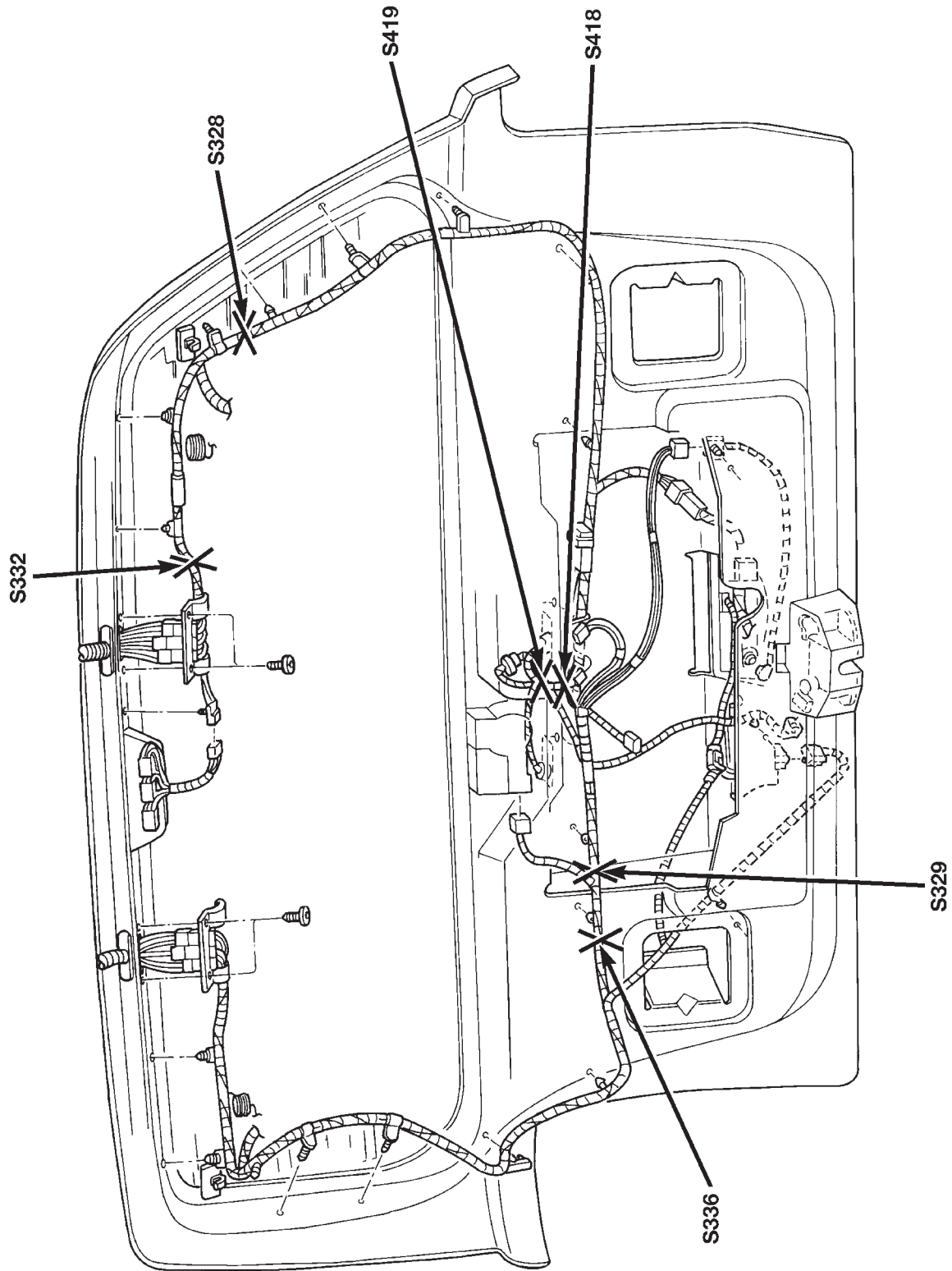


Fig. 11 Liftgate Splices — RHD

ENGINE

CONTENTS

	page		page
4.0L ENGINE	16	ENGINE DIAGNOSIS	8
5.2L ENGINE	55	STANDARD SERVICE INFORMATION	1
5.9L ENGINE	88		

STANDARD SERVICE INFORMATION

INDEX

	page		page
GENERAL INFORMATION		HYDROSTATIC LOCK	4
ENGINE OIL	5	MEASURING WITH PLASTIGAGE	3
ENGINE PERFORMANCE	2	REPAIR DAMAGED OR WORN THREADS	4
FORM-IN-PLACE GASKETS—GASOLINE		SERVICE ENGINE ASSEMBLY	
ENGINES	1	(SHORT BLOCK)	4
HONING CYLINDER BORES	2		

GENERAL INFORMATION

FORM-IN-PLACE GASKETS—GASOLINE ENGINES

There are several places where form-in-place gaskets are used on the engine. **DO NOT use form-in-place gasket material unless specified.** Care must be taken when applying form-in-place gaskets. Bead size, continuity, and location are of great importance. Too-thin a bead can result in leakage, while too much can result in spill-over. A continuous bead of the proper width is essential to obtain a leak-free joint.

Two types of form-in-place gasket materials are used in the engine area (Mopar® Silicone Rubber Adhesive Sealant and Mopar® Gasket Maker). Each has different properties and they cannot be used interchangeably.

MOPAR® SILICONE RUBBER ADHESIVE SEALANT

Mopar® Silicone Rubber Adhesive Sealant, normally black in color, is available in both three ounce tubes and four and one-half ounce power tubes. Moisture in the air causes the sealant material to cure. This material is normally used on flexible metal flanges. The regular tubes have a shelf life of one year and the power tubes a two year shelf life, and

will not properly cure if over-aged. Always inspect the package for the expiration date before use.

MOPAR® GASKET MAKER

Mopar® Gasket Maker, normally red in color, is available in six-cc tubes. This anaerobic type gasket material cures in the absence of air when squeezed between smooth machined metallic surfaces. It will not cure if left in the uncovered tube. DO NOT use on flexible metal flanges.

SURFACE PREPARATION

Parts assembled with form-in-place gaskets may be disassembled without unusual effort. In some instances, it may be necessary to lightly tap the part with a mallet, or other suitable tool, to break the seal between the mating surfaces. A flat gasket-scraper may also be lightly tapped into the joint, but care must be taken not to damage the mating surfaces.

Scrape or wire brush all gasket surfaces to remove all loose material. Inspect stamped parts to ensure that gasket rails are flat. Flatten rails with a hammer on a flat plate, if required. Gasket surfaces must be free of oil and dirt. Be sure the old gasket material is removed from blind attaching holes.

GENERAL INFORMATION (Continued)

GASKET APPLICATION

Assembling parts using a form-in-place gasket requires care.

Mopar® Silicone Rubber Adhesive Sealant should be applied in a continuous bead approximately 3 mm (0.12 inch) in diameter. All mounting holes must be circled. For corner sealing, a 3 or 6 mm (1/8 or 1/4 inch) drop is placed in the center of the gasket contact area. Uncured sealant may be removed with a shop towel. Components should be torqued in place while the sealant is still wet to the touch (within ten minutes). The use of a locating dowel is recommended during assembly to prevent smearing the material off location.

Mopar® Gasket Maker should be applied sparingly to one gasket surface. The sealant diameter should be 1.00 mm (0.04 inch) or less. Be certain the material surrounds each mounting hole. Excess material can be easily wiped off. Components should be torqued in place within 15 minutes. The use of a locating dowel is recommended during assembly to prevent smearing the material off location.

ENGINE PERFORMANCE

It is important that the vehicle is operating to its optimum performance level to maintain fuel economy and the lowest emission levels. If vehicle is not operating to these standards, refer to Engine Diagnosis outlined in this section. The following procedures can assist in achieving the proper engine diagnosis.

- (1) Test cranking amperage draw. Refer to Electrical Group 8B, Cold Cranking Test.
- (2) Check intake manifold bolt torque; Refer to Group 11, Exhaust System and Intake Manifold.
- (3) Perform cylinder compression test. Refer to Cylinder Compression Pressure Test in the Engine Diagnosis area of this section.
- (4) Clean or replace spark plugs as necessary and adjust gap as specified in Electrical Group 8D. Tighten to specifications.
- (5) Test resistance of spark plug cables. Refer to Electrical Group 8D, Spark Plug Cables.
- (6) Inspect the primary wires. Test coil output voltage and primary resistance. Replace parts as necessary. Refer to Electrical Group 8D, for specifications.
- (7) Test fuel pump for pressure. Refer to Group 14, Fuel System Specifications.
- (8) The air filter elements should be replaced as specified in Lubrication and Maintenance, Group 0.
- (9) Inspect crankcase ventilation system as outlined in Group 0, Lubrication and Maintenance. For emission controls see Group 25, Emission Controls for service procedures.
- (10) Road test vehicle as a final test.

HONING CYLINDER BORES

Before honing, stuff plenty of clean shop towels under the bores and over the crankshaft to keep abrasive materials from entering the crankshaft area.

(1) Used carefully, the Cylinder Bore Sizing Hone C-823 equipped with 220 grit stones, is the best tool for this job. In addition to deglazing, it will reduce taper and out-of-round as well as removing light scuffing, scoring or scratches. Usually a few strokes will clean up a bore and maintain the required limits.

CAUTION: DO NOT use rigid type hones to remove cylinder wall glaze.

(2) Deglazing of the cylinder walls may be done if the cylinder bore is straight and round. Use a cylinder surfacing hone, Honing Tool C-3501, equipped with 280 grit stones (C-3501-3810). 20-60 strokes, depending on the bore condition, will be sufficient to provide a satisfactory surface. Using honing oil C-3501-3880 or a light honing oil available from major oil distributors.

CAUTION: DO NOT use engine or transmission oil, mineral spirits or kerosene.

(3) Honing should be done by moving the hone up and down fast enough to get a crosshatch pattern. The hone marks should INTERSECT at 50° to 60° for proper seating of rings (Fig. 1).

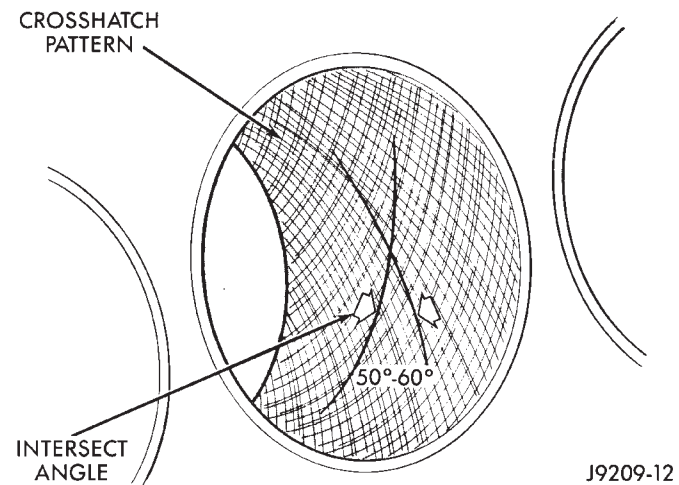


Fig. 1 Cylinder Bore Crosshatch Pattern

(4) A controlled hone motor speed between 200 and 300 RPM is necessary to obtain the proper crosshatch angle. The number of up and down strokes per minute can be regulated to get the desired 50° to 60° angle. Faster up and down strokes increase the crosshatch angle.

GENERAL INFORMATION (Continued)

(5) After honing, it is necessary that the block be cleaned to remove all traces of abrasive. Use a brush to wash parts with a solution of hot water and detergent. Dry parts thoroughly. Use a clean, white, lint-free cloth to check that the bore is clean. Oil the bores after cleaning to prevent rusting.

MEASURING WITH PLASTIGAGE

CRANKSHAFT MAIN BEARING CLEARANCE

Engine crankshaft bearing clearances can be determined by use of Plastigage, or equivalent. The following is the recommended procedures for the use of Plastigage:

(1) Remove oil film from surface to be checked. Plastigage is soluble in oil.

(2) The total clearance of the main bearings can only be determined by removing the weight of the crankshaft. This can be accomplished by either of two methods:

METHOD - 1 (PREFERRED)

Shim the bearings adjacent to the bearing to be checked. This will remove the clearance between upper bearing shell and the crankshaft. Place a minimum of 0.254 mm (0.010 inch) shim between the bearing shell and the adjacent bearing cap. Tighten the bolts to 18 N·m (13 ft. lbs.) torque.

- **ALL ENGINES**—When checking No.1 main bearing; shim No.2 main bearing.

- **ALL ENGINES**—When checking No.2 main bearing; shim No.1 and No.3 main bearing.

- **ALL ENGINES**—When checking No.3 main bearing; shim No.2 and No.4 main bearing.

- **ALL ENGINES**—When checking No.4 main bearing; shim No.3 and No.5 main bearing.

- **5.2/5.9L ENGINE**—When checking No.5 main bearing; shim No.4 main bearing.

- **4.0L ENGINE**—When checking No.5 main bearing; shim No.4 and No.6 main bearing.

- **4.0L ENGINE**—When checking No.6 main bearing; shim No.5 and No.7 main bearing.

- **4.0L ENGINE**—When checking No.7 main bearing; shim No.6 main bearing.

NOTE: Remove all shims before assembling engine.

METHOD - 2 (ALTERNATIVE)

The weight of the crankshaft is supported by a jack under the counterweight adjacent to the bearing being checked.

(1) Place a piece of Plastigage across the entire width of the bearing cap shell (Fig. 2). Position the Plastigage approximately 6.35 mm (1/4 inch) off center and away from the oil holes. In addition, suspect

areas can be checked by placing the Plastigage in that area. Tighten the bearing cap bolts of the bearing being checked to 108 N·m (80 ft. lbs.) torque (4.0L Engine). Tighten the bearing cap bolts of the bearing being checked to 115 N·m (85 ft. lbs.) torque (5.2/5.9L Engine). **DO NOT rotate the crankshaft or the Plastigage may be smeared, giving inaccurate results.**

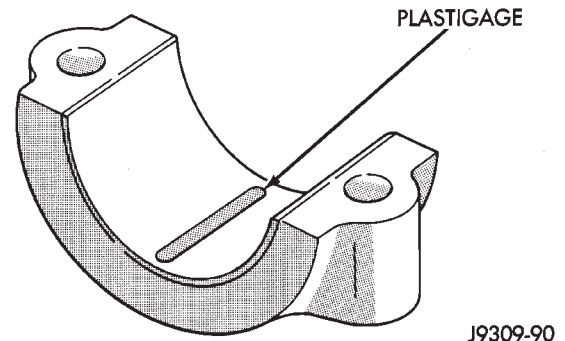


Fig. 2 Placement of Plastigage in Bearing Shell

(2) Remove the bearing cap and compare the width of the flattened Plastigage with the scale provided on the package (Fig. 3). Plastigage generally comes in 2 scales (one scale is in inches and the other is a metric scale). Locate the band closest to the same width. This band shows the amount of clearance. Differences in readings between the ends indicate the amount of taper present. Record all readings taken (refer to Engine Specifications).

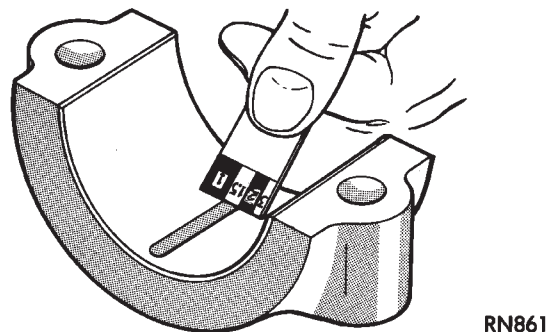


Fig. 3 Clearance Measurement

(3) Plastigage is available in a variety of clearance ranges. The 0.025-0.076 mm (0.001-0.003 inch) range is usually the most appropriate for checking engine bearing clearances.

CONNECTING ROD BEARING CLEARANCE

Engine connecting rod bearing clearances can be determined by use of Plastigage, or equivalent. The following is the recommended procedures for the use of Plastigage:

(1) Remove oil film from surface to be checked. Plastigage is soluble in oil.

GENERAL INFORMATION (Continued)

(2) Place a piece of Plastigage across the entire width of the bearing cap shell (Fig. 2). Position the Plastigage approximately 6.35 mm (1/4 inch) off center and away from the oil holes. In addition, suspect areas can be checked by placing the Plastigage in the suspect area.

(3) The crankshaft must be turned until the connecting rod to be checked starts moving toward the top of the engine. Only then should the rod cap with Plastigage in place be assembled. Tighten the 4.0L rod cap nut to 45 N·m (33 ft. lbs.) torque. Tighten the 5.2/5.9L rod cap nut to 61 N·m (45 ft. lbs.) torque. **DO NOT rotate the crankshaft or the Plastigage may be smeared, giving inaccurate results.**

(4) Remove the bearing cap and compare the width of the flattened Plastigage with the scale provided on the package (Fig. 3). Plastigage generally comes in 2 scales (one scale is in inches and the other is a metric scale). Locate the band closest to the same width. This band shows the amount of clearance. Differences in readings between the ends indicate the amount of taper present. Record all readings taken (refer to Engine Specifications).

(5) Plastigage is available in a variety of clearance ranges. The 0.025-0.076 mm (0.001-0.003 inch) range is usually the most appropriate for checking engine bearing clearances.

REPAIR DAMAGED OR WORN THREADS

Damaged or worn threads can be repaired. Essentially, this repair consists of:

- Drilling out worn or damaged threads.
- Tapping the hole with a special Heli-Coil Tap, or equivalent.
- Installing an insert into the tapped hole to bring the hole back to its original thread size.

CAUTION: Be sure that the tapped holes maintain the original center line.

Heli-Coil tools and inserts are readily available from automotive parts jobbers.

SERVICE ENGINE ASSEMBLY (SHORT BLOCK)

A service replacement engine assembly (short block) may be installed whenever the original cylinder block is defective or damaged beyond repair. It consists of the cylinder block, crankshaft, piston and rod assemblies. If needed, the camshaft must be procured separately and installed before the engine is installed in the vehicle.

A short block is identified with the letter "S" stamped on the same machined surface where the build date code is stamped for complete engine assemblies.

Installation includes the transfer of components from the defective or damaged original engine. Follow the appropriate procedures for cleaning, inspection and torque tightening.

HYDROSTATIC LOCK

When an engine is suspected of hydrostatic lock (regardless of what caused the problem), follow the steps below.

(1) Perform the Fuel Pressure Release Procedure (refer to Group 14, Fuel System).

(2) Disconnect the battery negative cable.

(3) Inspect air cleaner, induction system and intake manifold to ensure system is dry and clear of foreign material.

(4) Place a shop towel around the spark plugs to catch any fluid that may possibly be under pressure in the cylinder head. Remove the plugs from the engine.

CAUTION: DO NOT use the starter motor to rotate the crankshaft. Severe damage could occur.

(5) With all spark plugs removed, rotate the crankshaft using a breaker bar and socket.

(6) Identify the fluid in the cylinders (i.e. coolant, fuel, oil, etc.).

(7) Make sure all fluid has been removed from the cylinders.

(8) Repair engine or components as necessary to prevent this problem from occurring again.

(9) Squirt engine oil into the cylinders to lubricate the walls. This will prevent damage on restart.

(10) Install new spark plugs. Tighten the 4.0L engine spark plugs to 37 N·m (27 ft. lbs.) torque. Tighten the 5.2/5.9L engine spark plugs to 41 N·m (30 ft. lbs.) torque.

(11) Drain engine oil. Remove and discard the oil filter.

(12) Install the drain plug. Tighten the plug to 34 N·m (25 ft. lbs.) torque.

(13) Install a new oil filter.

(14) Fill engine crankcase with the specified amount and grade of oil.

(15) Connect the battery negative cable.

(16) Start the engine and check for any leaks.

GENERAL INFORMATION (Continued)

ENGINE OIL

WARNING: NEW OR USED ENGINE OIL CAN BE IRRITATING TO THE SKIN. AVOID PROLONGED OR REPEATED SKIN CONTACT WITH ENGINE OIL. CONTAMINANTS IN USED ENGINE OIL, CAUSED BY INTERNAL COMBUSTION, CAN BE HAZARDOUS TO YOUR HEALTH. THOROUGHLY WASH EXPOSED SKIN WITH SOAP AND WATER. DO NOT WASH SKIN WITH GASOLINE, DIESEL FUEL, THINNER, OR SOLVENTS, HEALTH PROBLEMS CAN RESULT. DO NOT POLLUTE, DISPOSE OF USED ENGINE OIL PROPERLY.

ENGINE OIL SPECIFICATION

CAUTION: Do not use non-detergent or straight mineral oil when adding or changing crankcase lubricant. Engine failure can result.

API SERVICE GRADE CERTIFIED

Use an engine oil that is API Service Grade Certified or an oil that conforms to the API Service Grade SH or SH/CD. MOPAR provides engine oils that conform to all of these service grades.

SAE VISCOSITY

An SAE viscosity grade is used to specify the viscosity of engine oil. SAE 30 specifies a single viscosity engine oil. Engine oils also have multiple viscosities. These are specified with a dual SAE viscosity grade which indicates the cold-to-hot temperature viscosity range. Select an engine oil that is best suited to your particular temperature range and variation (Fig. 4).

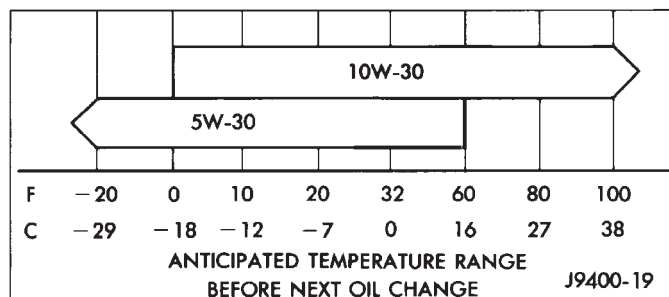


Fig. 4 Temperature/Engine Oil Viscosity

ENERGY CONSERVING OIL

An Energy Conserving type oil is recommended for gasoline engines. They are designated as either ENERGY CONSERVING or ENERGY CONSERVING II.

CONTAINER IDENTIFICATION

Standard engine oil identification notations have been adopted to aid in the proper selection of engine oil. The identifying notations are located on the label of engine oil plastic bottles and the top of engine oil cans (Fig. 5).



9400-9

Fig. 5 Engine Oil Container Standard Notations

OIL LEVEL INDICATOR (DIPSTICK)

The engine oil level indicator is located at the right rear of engine on 4.0L engines (Fig. 6) and the right front of the engine on 5.2/5.9L engines (Fig. 7).

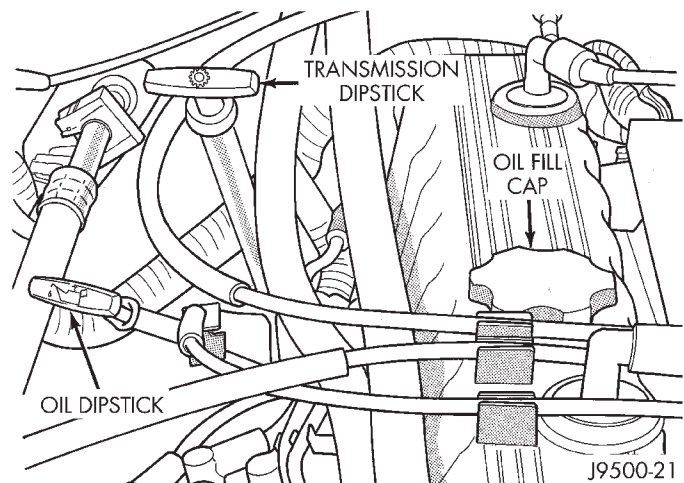


Fig. 6 Engine Oil Dipstick 4.0L Engine

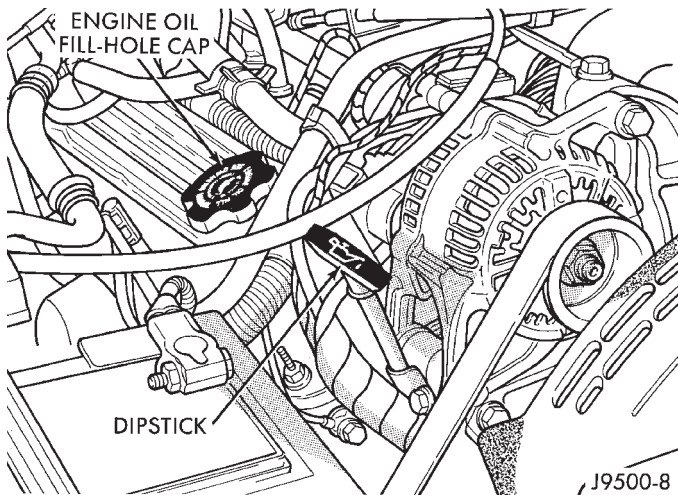
CRANKCASE OIL LEVEL INSPECTION

CAUTION: Do not overfill crankcase with engine oil, oil foaming and oil pressure loss can result.

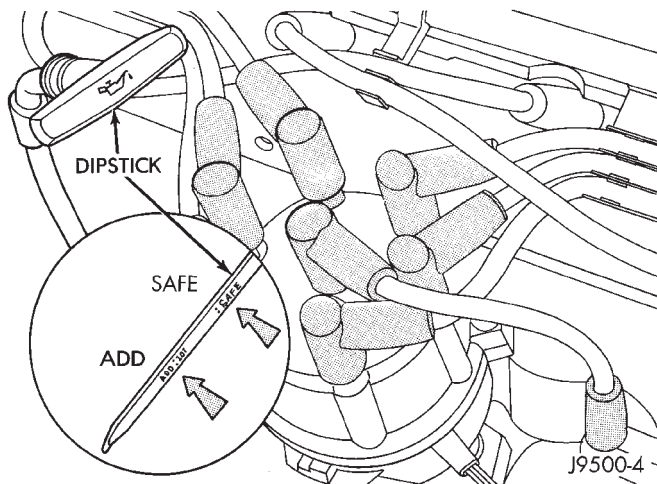
Inspect engine oil level approximately every 800 kilometers (500 miles). Unless the engine has exhibited loss of oil pressure, run the engine for about five minutes before checking oil level. Checking engine oil level on a cold engine is not accurate.

To ensure proper lubrication of an engine, the engine oil must be maintained at an acceptable level. The acceptable levels are indicated between the ADD and SAFE marks on the engine oil dipstick (Fig. 8).

- (1) Position vehicle on level surface.

GENERAL INFORMATION (Continued)**Fig. 7 Engine Oil Dipstick 5.2/5.9L Engine**

- (2) With engine OFF, allow approximately ten minutes for oil to settle to bottom of crankcase, remove engine oil dipstick.
- (3) Wipe dipstick clean.
- (4) Install dipstick and verify it is seated in the tube.
- (5) Remove dipstick, with handle held above the tip, take oil level reading (Fig. 8).
- (6) Add oil only if level is below the ADD mark on dipstick.

**Fig. 8 Engine Oil Dipstick—4.0L Engine****ENGINE OIL CHANGE**

Change engine oil at mileage and time intervals described in Maintenance Schedules.

Run engine until achieving normal operating temperature.

- (1) Position the vehicle on a level surface and turn engine off.
- (2) Hoist and support vehicle on safety stands.
- (3) Remove oil fill cap.
- (4) Place a suitable drain pan under crankcase drain.

(5) Remove drain plug from crankcase and allow oil to drain into pan. Inspect drain plug threads for stretching or other damage. Replace drain plug if damaged.

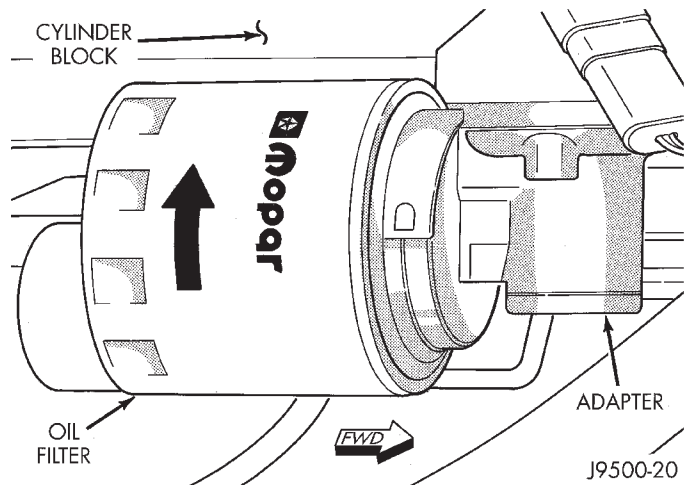
- (6) Install drain plug in crankcase.
- (7) Lower vehicle and fill crankcase with specified type and amount of engine oil described in this section.
- (8) Install oil fill cap.
- (9) Start engine and inspect for leaks.
- (10) Stop engine and inspect oil level.

ENGINE OIL FILTER CHANGE**FILTER SPECIFICATION**

All engines are equipped with a high quality full-flow, disposable type oil filter. Chrysler Corporation recommends a Mopar or equivalent oil filter be used.

OIL FILTER REMOVAL

- (1) Position a drain pan under the oil filter.
- (2) Using a suitable oil filter wrench loosen filter.
- (3) Rotate the oil filter counterclockwise (Fig. 9) to remove it from the cylinder block oil filter boss.

**Fig. 9 Oil Filter—4.0L Engine**

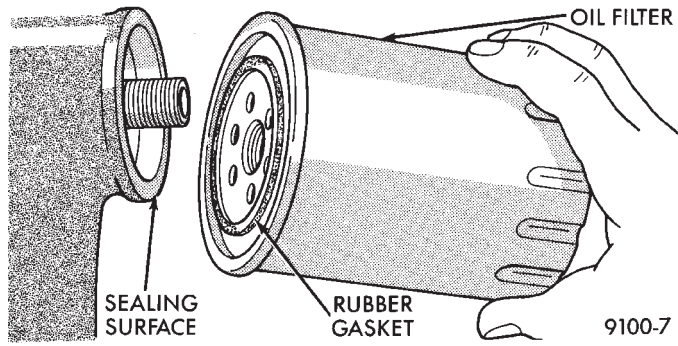
(4) When filter separates from adapter nipple, tip gasket end upward to minimize oil spill. Remove filter from vehicle.

(5) With a wiping cloth, clean the gasket sealing surface (Fig. 10) of oil and grime.

OIL FILTER INSTALLATION

- (1) Lightly lubricate oil filter gasket with engine oil or chassis grease.
- (2) Thread filter onto adapter nipple. When gasket makes contact with sealing surface, (Fig. 10) hand tighten filter one full turn, do not over tighten.
- (3) Add oil, verify crankcase oil level and start engine. Inspect for oil leaks.

GENERAL INFORMATION (Continued)



USED ENGINE OIL DISPOSAL

Care should be exercised when disposing used engine oil after it has been drained from a vehicle engine. Refer to the WARNING at beginning of this section.

Fig. 10 Oil Filter Sealing Surface—Typical

ENGINE DIAGNOSIS

INDEX

	page		page
DIAGNOSIS AND TESTING		ENGINE OIL PRESSURE	11
CYLINDER COMBUSTION PRESSURE		GENERAL INFORMATION	8
LEAKAGE TEST	9	HYDRAULIC TAPPETS	10
CYLINDER COMPRESSION PRESSURE TEST ..	8	INTAKE MANIFOLD LEAKAGE DIAGNOSIS	8
ENGINE CYLINDER HEAD GASKET FAILURE		SERVICE DIAGNOSIS—MECHANICAL	14
DIAGNOSIS	8	SERVICE DIAGNOSIS—PERFORMANCE	12
ENGINE OIL LEAK INSPECTION	9		

DIAGNOSIS AND TESTING

GENERAL INFORMATION

Engine diagnosis is helpful in determining the causes of malfunctions not detected and remedied by routine maintenance.

These malfunctions may be classified as either performance (e.g., engine idles rough and stalls) or mechanical (e.g., a strange noise).

Refer to the Service Diagnosis—Performance chart and the Service Diagnosis—Mechanical chart for possible causes and corrections of malfunctions. Refer to Group 14, Fuel System for the fuel system diagnosis.

Additional tests and diagnostic procedures may be necessary for specific engine malfunctions that can not be isolated with the Service Diagnosis charts. Information concerning additional tests and diagnosis is provided within the following diagnosis:

- Cylinder Compression Pressure Test.
- Cylinder Combustion Pressure Leakage Test.
- Engine Cylinder Head Gasket Failure Diagnosis.
- Intake Manifold Leakage Diagnosis.

INTAKE MANIFOLD LEAKAGE DIAGNOSIS

An intake manifold air leak is characterized by lower than normal manifold vacuum. Also, one or more cylinders may not be functioning.

WARNING: USE EXTREME CAUTION WHEN THE ENGINE IS OPERATING. DO NOT STAND IN A DIRECT LINE WITH THE FAN. DO NOT PUT YOUR HANDS NEAR THE PULLEYS, BELTS OR THE FAN. DO NOT WEAR LOOSE CLOTHING.

- (1) Start the engine.
- (2) Spray a small stream of water at the suspected leak area.
- (3) If a change in RPM is observed the area of the suspected leak has been found.
- (4) Repair as required.

CYLINDER COMPRESSION PRESSURE TEST

The results of a cylinder compression pressure test can be utilized to diagnose several engine malfunctions.

Ensure the battery is completely charged and the engine starter motor is in good operating condition. Otherwise the indicated compression pressures may not be valid for diagnosis purposes.

- (1) Clean the spark plug recesses with compressed air.
- (2) Remove the spark plugs.
- (3) Secure the throttle in the wide-open position.
- (4) Disable the fuel system. (Refer to Group 14, Fuel System for the correct procedure)
- (5) Disconnect the ignition coil.
- (6) Insert a compression pressure gauge and rotate the engine with the engine starter motor for three revolutions.
- (7) Record the compression pressure on the 3rd revolution. Continue the test for the remaining cylinders.

Refer to Engine Specifications for the correct engine compression pressures.

ENGINE CYLINDER HEAD GASKET FAILURE DIAGNOSIS

A leaking engine cylinder head gasket usually results in loss of power, loss of coolant and engine misfiring.

An engine cylinder head gasket leak can be located between adjacent cylinders or between a cylinder and the adjacent water jacket.

- An engine cylinder head gasket leaking between adjacent cylinders is indicated by a loss of power and/or engine misfire.
- An engine cylinder head gasket leaking between a cylinder and an adjacent water jacket is indicated by coolant foaming or overheating and loss of coolant.

DIAGNOSIS AND TESTING (Continued)

CYLINDER-TO-CYLINDER LEAKAGE TEST

To determine if an engine cylinder head gasket is leaking between adjacent cylinders; follow the procedures outlined in Cylinder Compression Pressure Test. An engine cylinder head gasket leaking between adjacent cylinders will result in approximately a 50-70% reduction in compression pressure.

CYLINDER-TO-WATER JACKET LEAKAGE TEST

WARNING: USE EXTREME CAUTION WHEN THE ENGINE IS OPERATING. DO NOT STAND IN A DIRECT LINE WITH THE FAN. DO NOT PUT YOUR HANDS NEAR THE PULLEYS, BELTS OR THE FAN. DO NOT WEAR LOOSE CLOTHING.

Remove the radiator cap.

Start the engine and allow it to warm up until the engine thermostat opens.

If a large combustion/compression pressure leak exists, bubbles will be visible in the coolant.

If bubbles are not visible, install a radiator pressure tester and pressurize the coolant system.

If a cylinder is leaking combustion pressure into the water jacket, the tester pointer will pulsate with every combustion stroke of the cylinder.

CYLINDER COMBUSTION PRESSURE LEAKAGE TEST

The combustion pressure leakage test provides an accurate means for determining engine condition.

Combustion pressure leakage testing will detect:

- Exhaust and intake valve leaks (improper seating).
- Leaks between adjacent cylinders or into water jacket.
- Any causes for combustion/compression pressure loss.

(1) Check the coolant level and fill as required. DO NOT install the radiator cap.

(2) Start and operate the engine until it attains normal operating temperature, then turn the engine OFF.

(3) Remove the spark plugs.

(4) Remove the oil filler cap.

(5) Remove the air cleaner.

(6) Calibrate the tester according to the manufacturer's instructions. The shop air source for testing should maintain 483 kPa (70 psi) minimum, 1,379 kPa (200 psi) maximum and 552 kPa (80 psi) recommended.

(7) Perform the test procedures on each cylinder according to the tester manufacturer's instructions. While testing, listen for pressurized air escaping through the throttle body, tailpipe and oil filler cap opening. Check for bubbles in the radiator coolant.

All gauge pressure indications should be equal, with no more than 25% leakage.

FOR EXAMPLE: At 552 kPa (80 psi) input pressure, a minimum of 414 kPa (60 psi) should be maintained in the cylinder.

Refer to the Cylinder Combustion Pressure Leakage Test Diagnosis chart.

ENGINE OIL LEAK INSPECTION

Begin with a thorough visual inspection of the engine, particularly at the area of the suspected leak. If an oil leak source is not readily identifiable, the following steps should be followed:

(1) Do not clean or degrease the engine at this time because some solvents may cause rubber to swell, temporarily stopping the leak.

(2) Add an oil soluble dye (use as recommended by manufacturer). Start the engine and let idle for approximately 15 minutes. Check the oil dipstick to make sure the dye is thoroughly mixed as indicated with a bright yellow color under a black light.

(3) Using a black light, inspect the entire engine for fluorescent dye, particularly at the suspected area of oil leak. If the oil leak is found and identified, repair per service manual instructions.

(4) If dye is not observed, drive the vehicle at various speeds for approximately 24km (15 miles), and repeat inspection.

(5) **If the oil leak source is not positively identified at this time**, proceed with the air leak detection test method.

Air Leak Detection Test Method

(1) Disconnect the breather cap to air cleaner hose at the breather cap end. Cap or plug breather cap nipple.

(2) Remove the PCV valve from the cylinder head cover. Cap or plug the PCV valve grommet.

(3) Attach an air hose with pressure gauge and regulator to the dipstick tube.

CAUTION: Do not subject the engine assembly to more than 20.6 kpa (3 PSI) of test pressure.

(4) Gradually apply air pressure from 1 psi to 2.5 psi maximum while applying soapy water at the suspected source. Adjust the regulator to the suitable test pressure that provide the best bubbles which will pinpoint the leak source. If the oil leak is detected and identified, repair per service manual procedures.

(5) If the leakage occurs at the rear oil seal area, refer to the section, Inspection for Rear Seal Area Leak.

(6) If no leaks are detected, turn off the air supply and remove the air hose and all plugs and caps. Install the PCV valve and breather cap hose.

DIAGNOSIS AND TESTING (Continued)**CYLINDER COMBUSTION PRESSURE LEAKAGE DIAGNOSIS CHART**

CONDITION	POSSIBLE CAUSE	CORRECTION
AIR ESCAPES THROUGH THROTTLE BODY	Intake valve bent, burnt, or not seated properly	Inspect valve and valve seat. Reface or replace, as necessary
AIR ESCAPES THROUGH TAILPIPE	Exhaust valve bent, burnt, or not seated properly	Inspect valve and valve seat. Reface or replace, as necessary
AIR ESCAPES THROUGH RADIATOR	Head gasket leaking or cracked cylinder head or block	Remove cylinder head and inspect. Replace defective part
MORE THAN 50% LEAKAGE FROM ADJACENT CYLINDERS	Head gasket leaking or crack in cylinder head or block between adjacent cylinders	Remove cylinder head and inspect. Replace gasket, head, or block as necessary
MORE THAN 25% LEAKAGE AND AIR ESCAPES THROUGH OIL FILLER CAP OPENING ONLY	Stuck or broken piston rings; cracked piston; worn rings and/or cylinder wall	Inspect for broken rings or piston. Measure ring gap and cylinder diameter, taper and out-of-round. Replace defective part as necessary

(7) Clean the oil off the suspect oil leak area using a suitable solvent. Drive the vehicle at various speeds approximately 24 km (15 miles). Inspect the engine for signs of an oil leak by using a black light.

INSPECTION FOR REAR SEAL AREA LEAKS

Since it is sometimes difficult to determine the source of an oil leak in the rear seal area of the engine, a more involved inspection is necessary. The following steps should be followed to help pinpoint the source of the leak.

If the leakage occurs at the crankshaft rear oil seal area:

- (1) Disconnect the battery.
- (2) Raise the vehicle.
- (3) Remove torque converter or clutch housing cover and inspect rear of block for evidence of oil. Use a black light to check for the oil leak:

(a) Circular spray pattern generally indicates seal leakage or crankshaft damage.

(b) Where leakage tends to run straight down, possible causes are a porous block, distributor seal, camshaft bore cup plugs oil galley pipe plugs, oil filter runoff, and main bearing cap to cylinder block mating surfaces.

- (4) If no leaks are detected, pressurize the crankcase as outlined in the, Inspection (Engine oil Leaks in general)

CAUTION: Do not exceed 20.6 kPa (3 psi).

(5) If the leak is not detected, very slowly turn the crankshaft and watch for leakage. If a leak is detected between the crankshaft and seal while slowly turning the crankshaft, it is possible the crankshaft seal surface is damaged. The seal area on the crankshaft could have minor nicks or scratches that can be polished out with emery cloth.

CAUTION: Use extreme caution when crankshaft polishing is necessary to remove minor nicks and scratches. The crankshaft seal flange is especially machined to complement the function of the rear oil seal.

(6) For bubbles that remain steady with shaft rotation, no further inspection can be done until disassembled.

HYDRAULIC TAPPETS

Before disassembling any part of the engine to correct tappet noise, check the oil pressure. If vehicle has no oil pressure gauge, install a reliable gauge at the pressure sending-unit. The pressure should be between 207-552 kPa (30-80 psi) at 3,000 RPM.

Check the oil level after the engine reaches normal operating temperature. Allow 5 minutes to stabilize oil level, check dipstick. The oil level in the pan should never be above the FULL mark or below the ADD OIL mark on dipstick. Either of these two conditions could be responsible for noisy tappets.

OIL LEVEL**HIGH**

If oil level is above the FULL mark, it is possible for the connecting rods to dip into the oil. With the engine running, this condition could create foam in the oil pan. Foam in oil pan would be fed to the hydraulic tappets by the oil pump causing them to lose length and allow valves to seat noisily.

LOW

Low oil level may allow oil pump to take in air. When air is fed to the tappets, they lose length, which allows valves to seat noisily. Any leaks on intake side of oil pump through which air can be

DIAGNOSIS AND TESTING (Continued)

drawn will create the same tappet action. Check the lubrication system from the intake strainer to the pump cover, including the relief valve retainer cap. When tappet noise is due to aeration, it may be intermittent or constant, and usually more than one tappet will be noisy. When oil level and leaks have been corrected, operate the engine at fast idle. Run engine for a sufficient time to allow all of the air inside the tappets to be bled out.

TAPPET NOISE DIAGNOSIS

(1) To determine source of tappet noise, operate engine at idle with cylinder head covers removed.

(2) Feel each valve spring or rocker arm to detect noisy tappet. The noisy tappet will cause the affected spring and/or rocker arm to vibrate or feel rough in operation.

NOTE: Worn valve guides or cocked springs are sometimes mistaken for noisy tappets. If such is the case, noise may be dampened by applying side thrust on the valve spring. If noise is not appreciably reduced, it can be assumed the noise is in the tappet. Inspect the rocker arm push rod sockets and push rod ends for wear.

(3) Valve tappet noise ranges from light noise to a heavy click. A light noise is usually caused by exces-

sive leak-down around the unit plunger, or by the plunger partially sticking in the tappet body cylinder. The tappet should be replaced. A heavy click is caused by a tappet check valve not seating, or by foreign particles wedged between the plunger and the tappet body. This will cause the plunger to stick in the down position. This heavy click will be accompanied by excessive clearance between the valve stem and rocker arm as valve closes. In either case, tappet assembly should be removed for inspection and cleaning.

(4) The valve train generates a noise very much like a light tappet noise during normal operation. Care must be taken to ensure that tappets are making the noise. If more than one tappet seems to be noisy, it's probably not the tappets.

ENGINE OIL PRESSURE

(1) Disconnect connector and remove oil pressure sending unit.

(2) Install Oil Pressure Line and Gauge Tool C-3292 or equivalent. Start engine and record pressure. Refer to Oil Pressure in Engine Specifications for the correct pressures.

DIAGNOSIS AND TESTING (Continued)**SERVICE DIAGNOSIS—PERFORMANCE****ENGINE PERFORMANCE DIAGNOSIS CHART**

CONDITION	POSSIBLE CAUSES	CORRECTION
ENGINE WILL NOT CRANK	<ol style="list-style-type: none"> 1. Weak or dead battery 2. Corroded or loose battery connections 3. Faulty starter or related circuit(s) 4. Seized accessory drive component 5. Engine internal mechanical failure or hydro-static lock 	<ol style="list-style-type: none"> 1. Charge/Replace Battery. Refer to Group 8A, Battery, for correct procedures. Check charging system. Refer to Group 8C, Charging Systems, for correct procedures. 2. Clean/tighten suspect battery/ starter connections 3. Check starting system. Refer to Group 8B, Starting Systems, for correct diagnostics/procedures 4. Remove accessory drive belt and attempt to start engine. If engine starts, repair/replace seized component. 5. Refer to Group 9, Engine, for correct diagnostics/procedures
ENGINE CRANKS BUT WILL NOT START	<ol style="list-style-type: none"> 1. No spark 2. No fuel 3. Low or no engine compression 	<ol style="list-style-type: none"> 1. Check for spark. Refer to Group 8D, Ignition System, for correct procedures. 2. Perform fuel pressure test, and if necessary, inspect fuel injector(s) and driver circuits. Refer to Group 14, Fuel System, for correct procedures. 3. Perform cylinder compression pressure test. Refer to Group 9, Engine, for correct procedures.
ENGINE LOSS OF POWER	<ol style="list-style-type: none"> 1. Worn or burned distributor rotor 2. Worn distributor shaft 3. Worn or incorrect gapped spark plugs 4. Dirt or water in fuel system 5. Faulty fuel pump 6. Incorrect valve timing 7. Blown cylinder head gasket 8. Low compression 9. Burned, warped, or pitted valves 10. Plugged or restricted exhaust system 11. Faulty ignition cables 12. Faulty ignition coil 	<ol style="list-style-type: none"> 1. Install new distributor rotor 2. Remove and repair distributor (Refer to group 8D, Ignition System) 3. Clean plugs and set gap. (Refer to group 8D, Ignition System) 4. Clean system and replace fuel filter 5. Install new fuel pump 6. Correct valve timing 7. Install new cylinder head gasket 8. Test cylinder compression 9. Install/Reface valves as necessary 10. Install new parts as necessary 11. Replace any cracked or shorted cables 12. Test and replace, as necessary (Refer to Group 8D, ignition system)

DIAGNOSIS AND TESTING (Continued)

CONDITION	POSSIBLE CAUSES	CORRECTION
ENGINE STALLS OR ROUGH IDLE	<ol style="list-style-type: none"> 1. Carbon build-up on throttle plate 2. Engine idle speed too low 3. Worn or incorrectly gapped spark plugs 4. Worn or burned distributor rotor 5. Spark plug cables defective or crossed 6. Faulty coil 7. Intake manifold vacuum leak 8. EGR valve leaking or stuck open 	<ol style="list-style-type: none"> 1. Remove throttle body and de-carbon. (Refer to Group 14 for correct procedures) 2. Check Idle Air Control circuit. (Refer to Group 14, Fuel System) 3. Replace or clean and re-gap spark plugs (Refer to group 8D, Ignition System) 4. Install new distributor rotor 5. Check for correct firing order or replace spark plug cables. (Refer to Group 8D, Ignition System for correct procedures.) 6. Test and replace, if necessary (Refer to group 8D, Ignition System) 7. Inspect intake manifold gasket and vacuum hoses. Replace if necessary (Refer to Group 11, Exhaust System & Intake Manifold) 8. Test and replace, if necessary (Refer to group 25, Emission Control Systems)
ENGINE MISSES ON ACCELERATION	<ol style="list-style-type: none"> 1. Worn or incorrectly gapped spark plugs 2. Spark plug cables defective or crossed 3. Dirt in fuel system 4. Burned, warped or pitted valves 5. Faulty coil 	<ol style="list-style-type: none"> 1. Replace spark plugs or clean and set gap. (Refer to group 8D, Ignition System) 2. Check Idle Air Control circuit. (Refer to Group 14, Fuel System) 3. Clean fuel system 4. Install new valves 5. Test and replace as necessary (refer to group 8D, Ignition System)

DIAGNOSIS AND TESTING (Continued)**SERVICE DIAGNOSIS—MECHANICAL****ENGINE MECHANICAL DIAGNOSIS CHART**

CONDITION	POSSIBLE CAUSES	CORRECTION
NOISY VALVES/LIFTERS	<ol style="list-style-type: none"> 1. High or low oil level in crankcase 2. Thin or diluted oil 3. Low oil pressure 4. Dirt in tappets/lash adjusters 5. Bent push rod(s) 6. Worn rocker arms 7. Worn tappets/lash adjusters 8. Worn valve guides 9. Excessive runout of valve seats or valve faces 	<ol style="list-style-type: none"> 1. Check for correct oil level. Adjust oil level by draining or adding as needed 2. Change oil (Refer to Engine Oil Service in this group) 3. Check engine oil level. If ok, Perform oil pressure test. Refer to this group for engine oil pressure test/specifications 4. Clean/replace hydraulic tappets/lash adjusters 5. Install new push rods 6. Inspect oil supply to rocker arms and replace worn arms as needed 7. Install new hydraulic tappets/lash adjusters 8. Inspect all valve guides and replace as necessary 9. Grind valves and seats
CONNECTING ROD NOISE	<ol style="list-style-type: none"> 1. Insufficient oil supply 2. Low oil pressure 3. Thin or diluted oil 4. Excessive connecting rod bearing clearance 5. Connecting rod journal out of round 6. Misaligned connecting rods 	<ol style="list-style-type: none"> 1. Check engine oil level. (Refer to group 0, Lubrication and Maintenance) 2. Check engine oil level. If ok, Perform oil pressure test. Refer to this group for engine oil pressure test/specifications 3. Change oil to correct viscosity. Refer to this group for correct procedure/engine oil specifications Measure bearings for correct clearance with plasti-gage. Repair as necessary 5. Replace crankshaft or grind journals 6. Replace bent connecting rods
MAIN BEARING NOISE	<ol style="list-style-type: none"> 1. Insufficient oil supply 2. Low oil pressure 3. Thin or diluted oil 4. Excessive main bearing clearance 5. Excessive end play 	<ol style="list-style-type: none"> 1. Check engine oil level. (Refer to group 0, Lubrication and Maintenance) 2. Check engine oil level. If ok, Perform oil pressure test. Refer to this group for engine oil pressure test/specifications 3. Change oil to correct viscosity. Refer to this group for correct procedure/engine oil specifications 4. Measure bearings for correct clearance. Repair as necessary 5. Check crankshaft thrust bearing for excessive wear on flanges

DIAGNOSIS AND TESTING (Continued)

CONDITION	POSSIBLE CAUSES	CORRECTION
MAIN BEARING NOISE (CONT'D)	6. Crankshaft main journal out of round or worn 7. Loose flywheel or torque converter	6. Grind journals or replace crankshaft 7. Inspect crankshaft, flexplate/flywheel and bolts for damage. Tighten to correct torque
LOW OIL PRESSURE	1. Low oil level 2. Faulty oil pressure sending unit 3. Clogged oil filter 4. Worn oil pump 5. Thin or diluted oil 6. Excessive bearing clearance 7. Oil pump relief valve stuck 8. Oil pump suction tube loose, broken, bent or clogged 9. Oil pump cover warped or cracked	1. Check oil level and fill if necessary 2. Install new sending unit 3. Install new oil filter 4. Replace worn gears or oil pump assy 5. Change oil to correct viscosity. Refer to this group for correct procedure/engine oil specifications 6. Measure bearings for correct clearance 7. Remove valve to inspect, clean and reinstall 8. Inspect suction tube and clean or replace if necessary 9. Install new oil pump
OIL LEAKS	1. Misaligned or deteriorated gaskets 2. Loose fastener, broken or porous metal part 3. Front or rear crankshaft oil seal leaking 4. Leaking oil gallery plug or cup plug	1. Replace gasket 2. Tighten, repair or replace the part 3. Replace seal 4. Remove and reseal threaded plug. Replace cup style plug
EXCESSIVE OIL CONSUMPTION OR SPARK PLUGS OIL FOULED	1. PCV System malfunction 2. Defective valve stem seal(s) 3. Worn or broken piston rings 4. Scuffed pistons/cylinder walls 5. Carbon in oil control ring groove 6. Worn valve guides 7. Piston rings fitted too tightly in grooves	1. Refer to group 25, Emission Control System for correct operation 2. Repair or replace seal(s) 3. Hone cylinder bores. Install new rings 4. Hone cylinder bores and replace pistons as required 5. Remove rings and de-carbon piston 6. Inspect/replace valve guides as necessary 7. Remove rings and check ring end gap and side clearance. Replace if necessary

4.0L ENGINE

INDEX

	page		page
DESCRIPTION AND OPERATION			
ENGINE DESCRIPTION	16	OIL PUMP	46
LUBRICATION SYSTEM	17	PISTONS AND CONNECTING RODS	44
OIL PUMP PRESSURE	19	REAR MAIN OIL SEALS	45
OVERSIZE AND UNDERSIZE COMPONENT CODES	19	ROCKER ARMS AND PUSH RODS	32
SERVICE PROCEDURES			
FITTING CONNECTING ROD BEARINGS	22	TIMING CASE COVER OIL SEAL	47
FITTING CRANKSHAFT MAIN BEARINGS	24	TIMING CASE COVER	37
PISTON FITTING	19	TIMING CHAIN AND SPROCKETS	37
PISTON RING FITTING	20	VALVE STEM SEAL AND SPRING	33
VALVE TIMING	19	VALVES AND VALVE SPRINGS	35
REMOVAL AND INSTALLATION			
CAMSHAFT PIN REPLACEMENT	40	VIBRATION DAMPER	36
CAMSHAFT	39	DISASSEMBLY AND ASSEMBLY	
CRANKSHAFT MAIN BEARINGS	42	CYLINDER BLOCK	49
CYLINDER HEAD COVER	31	VALVE SERVICE	47
CYLINDER HEAD	33	CLEANING AND INSPECTION	
ENGINE ASSEMBLY	29	CYLINDER BLOCK	51
ENGINE MOUNTS—FRONT	28	CYLINDER HEAD COVER	50
ENGINE MOUNT—REAR	28	CYLINDER HEAD	50
HYDRAULIC TAPPETS	36	HYDRAULIC TAPPETS	50
OIL PAN	43	ROCKER ARMS AND PUSH RODS	50
		SPECIFICATIONS	
		4.0L ENGINE SPECIFICATIONS	52
		SPECIAL TOOLS	
		4.0L ENGINE	54

DESCRIPTION AND OPERATION

ENGINE DESCRIPTION

The 4.0 Liter (242 CID) six-cylinder engine is an In-line, lightweight, overhead valve engine. This engine is designed for unleaded fuel.

The engine cylinder head has dual quench-type combustion chambers that create turbulence and fast burning of the air/fuel mixture. This results in good fuel economy.

The cylinders are numbered 1 through 6 from front to rear. The firing order is 1-5-3-6-2-4 (Fig. 1).

The crankshaft rotation is clockwise, when viewed from the front of the engine. The crankshaft rotates within seven main bearings. The camshaft rotates within four bearings.

BUILD DATE CODE

The engine Build Date Code is located on a machined surface on the right side of the cylinder block between the No.2 and No.3 cylinders (Fig. 2).

The digits of the code identify:

- 1st Digit—The year (8 = 1998).
- 2nd & 3rd Digits—The month (01 - 12).

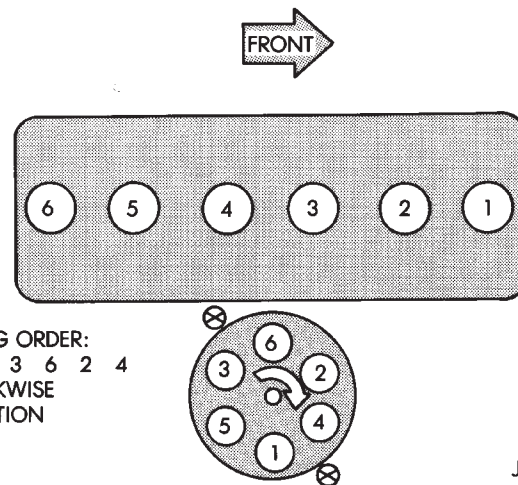


Fig. 1 Engine Firing Order

- 4th & 5th Digits—The engine type/fuel system/compression ratio (MX = A 4.0 Liter (242 CID) 8.7:1 compression ratio engine with a multi-point fuel injection system).
- 6th & 7th Digits—The day of engine build (01 - 31).

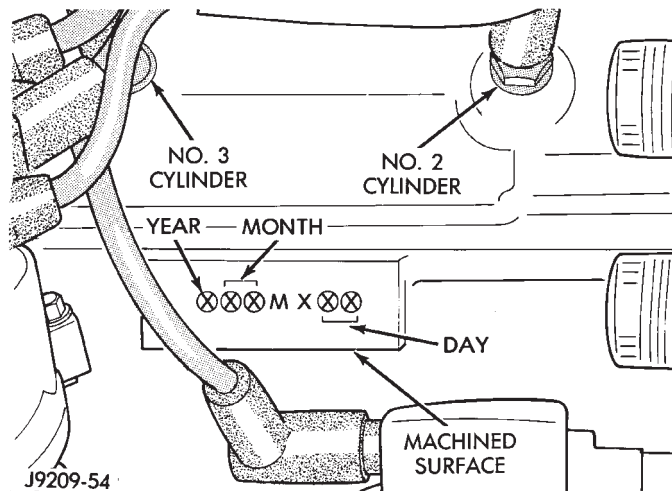
DESCRIPTION AND OPERATION (Continued)

Fig. 2 Build Date Code Location

(1) **FOR EXAMPLE:** Code * 801MX12 * identifies a 4.0 Liter (242 CID) engine with a multi-point fuel injection system, 8.7:1 compression ratio and built on January 12, 1998.

LUBRICATION SYSTEM

A gear-type positive displacement pump is mounted at the underside of the block opposite the No. 4 main bearing. The pump draws oil through the screen and inlet tube from the sump at the rear of the oil pan. The oil is driven between the drive and idler gears and pump body, then forced through the outlet to the block. An oil gallery in the block chan-

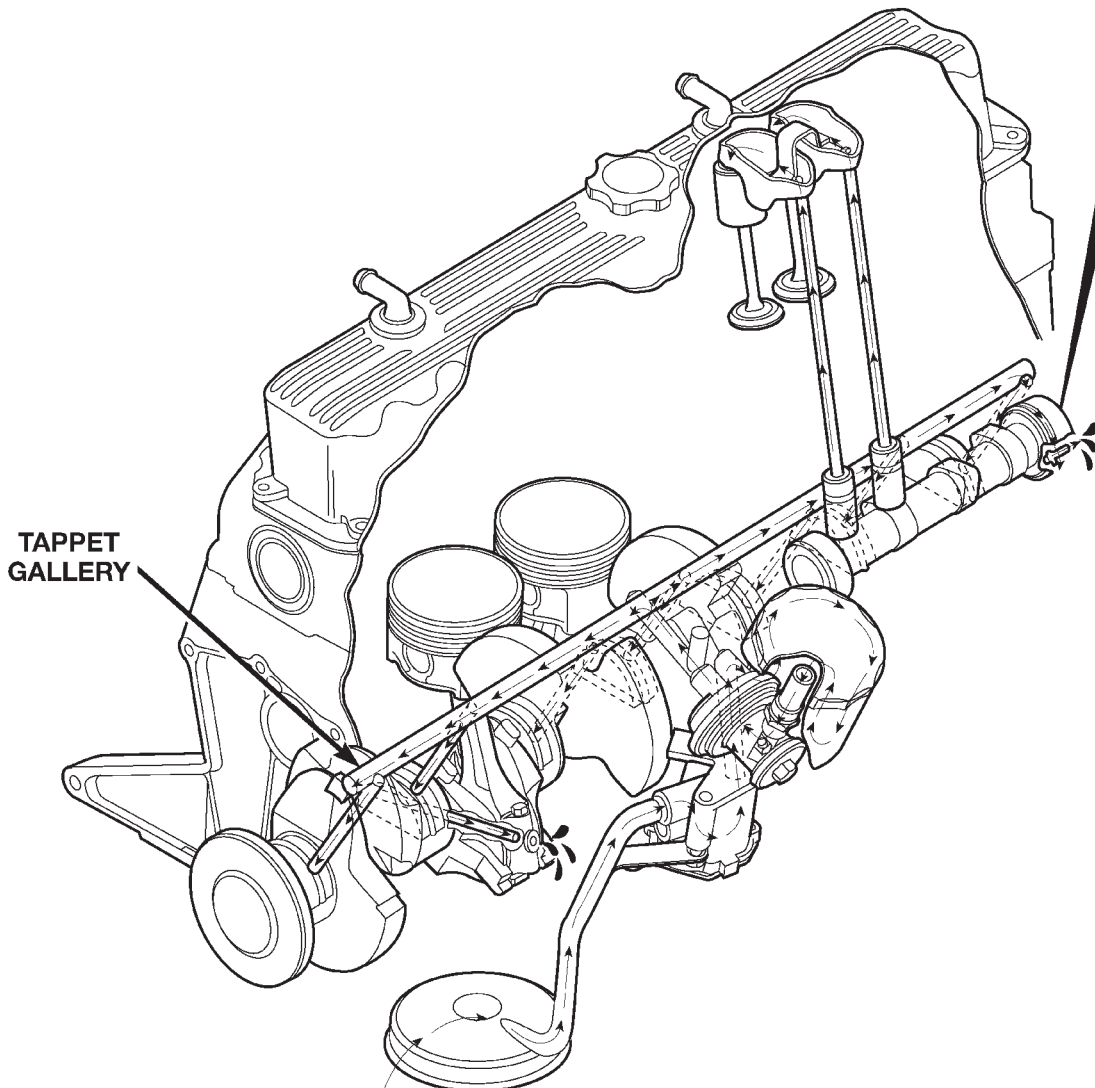
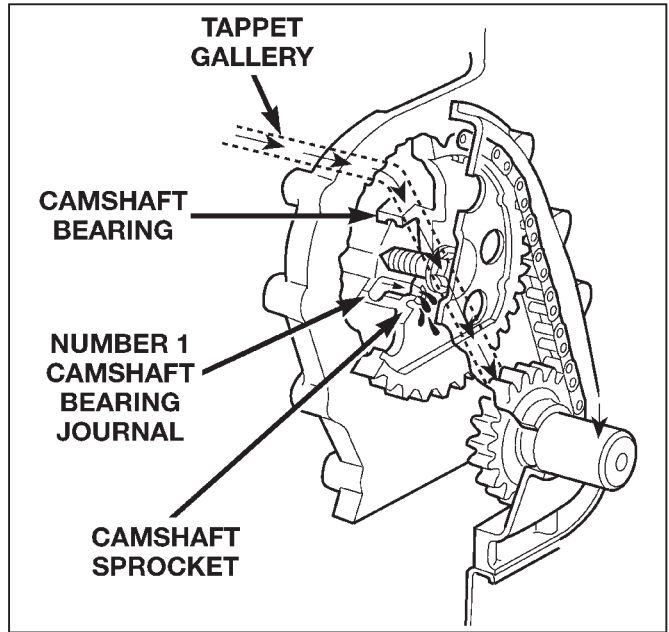
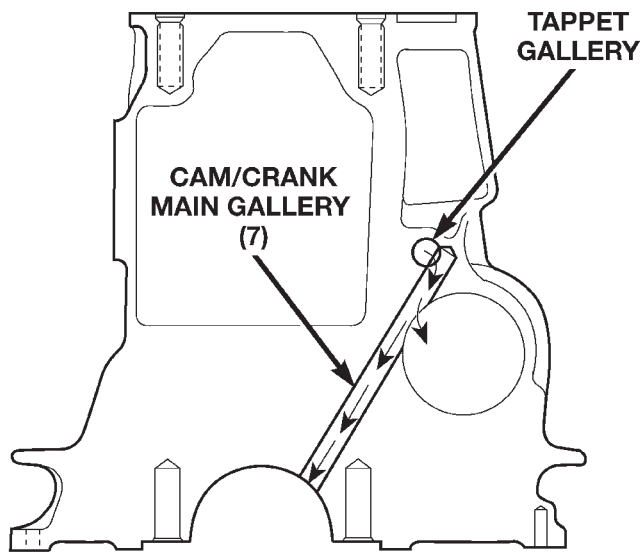
nels the oil to the inlet side of the full flow oil filter. After passing through the filter element, the oil passes from the center outlet of the filter through an oil gallery that channels the oil up to the main gallery which extends the entire length of the block.

Galleries extend downward from the main oil gallery to the upper shell of each main bearing. The crankshaft is drilled internally to pass oil from the main bearing journals (except number 4 main bearing journal) to the connecting rod journals. Each connecting rod bearing cap has a small squirt hole, oil passes through the squirt hole and is thrown off as the rod rotates. This oil throwoff lubricates the camshaft lobes, distributor drive gear, cylinder walls, and piston pins.

The hydraulic valve tappets receive oil directly from the main oil gallery. Oil is provided to the camshaft bearing journal passes oil through the camshaft sprocket to the timing chain. Oil drains back to the oil pan under the number one main bearing cap.

The oil supply for the rocker arms and bridged pivot assemblies is provided by the hydraulic valve tappets which pass oil through hollow push rods to a hole in the corresponding rocker arm. Oil from the rocker arm lubricates the valve train components, then passes down through the push rod guide holes in the cylinder head past the valve tappet area, and returns to the oil pan.

DESCRIPTION AND OPERATION (Continued)



Oil Lubrication System—4.0L Engine

DESCRIPTION AND OPERATION (Continued)**OIL PUMP PRESSURE**

The MINIMUM oil pump pressure is 89.6 kPa (13 psi) at 600 rpm. The NORMAL oil pump pressure is 517 kPa (75 psi) at 1600 rpm or more.

OVERSIZE AND UNDERSIZE COMPONENT CODES

Some engines may be built with oversize or undersize components such as:

- Oversize cylinder bores.
- Oversize camshaft bearing bores.
- Undersize crankshaft main bearing journals.
- Undersize connecting rod journals.

These engines are identified by a letter code (Fig. 3) stamped on a boss between the ignition coil and the distributor (Fig. 4).

CODE	COMPONENT	UNDERSIZE
P	One or more connecting rod bearing journals	0.254 mm (0.010 in)
M	All crankshaft main bearing journals	0.254 mm (0.010 in)
PM	All crankshaft main bearing journals and one or more connecting rod journals	0.254 mm (0.010 in)
CODE	COMPONENT	OVERSIZE
B	All cylinder bores	0.254 mm (0.010 in)
C	All camshaft bearing bores	0.254 mm (0.010 in)

J8909-54

Fig. 3 Oversize and Undersize Component Codes

SERVICE PROCEDURES**VALVE TIMING**

Disconnect the spark plug wires and remove the spark plugs.

Remove the engine cylinder head cover.

Remove the capscrews, bridge and pivot assembly, and rocker arms from above the No.1 cylinder.

Alternately loosen each capscrew, one turn at a time, to avoid damaging the bridge.

Rotate the crankshaft until the No.6 piston is at top dead center (TDC) on the compression stroke.

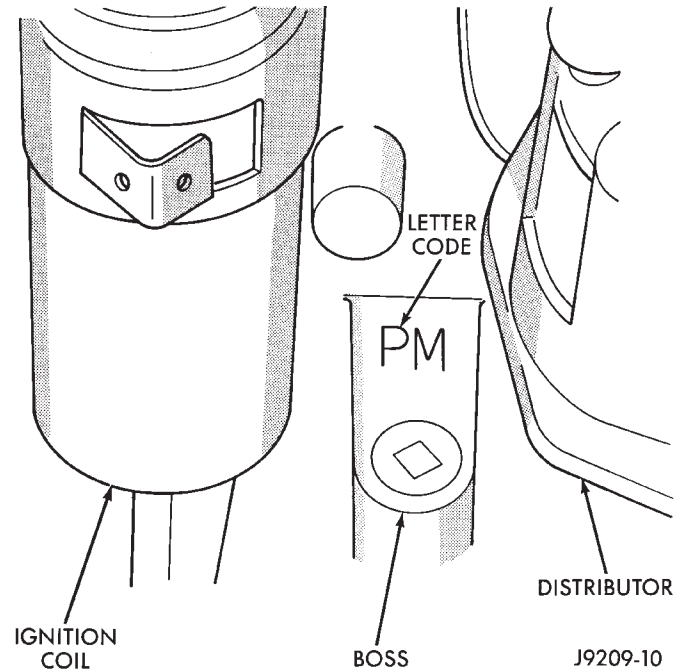


Fig. 4 Oversize and Undersize Component Code Location

Rotate the crankshaft counterclockwise (viewed from the front of the engine) 90°.

Install a dial indicator on the end of the No.1 cylinder intake valve push rod. Use rubber tubing to secure the indicator stem on the push rod.

Set the dial indicator pointer at zero.

Rotate the crankshaft clockwise (viewed from the front of the engine) until the dial indicator pointer indicates 0.305 mm (0.012 inch) travel distance (lift).

The timing notch index on the vibration damper should be aligned with the TDC mark on the timing degree scale.

If the timing notch is more than 13 mm (1/2 inch) away from the TDC mark in either direction, the valve timing is incorrect.

If the valve timing is incorrect, the cause may be a broken camshaft pin. It is not necessary to replace the camshaft because of pin failure. A spring pin is available for service replacement.

PISTON FITTING**BORE GAGE METHOD**

(1) To correctly select the proper size piston, a cylinder bore gauge, capable of reading in 0.003 mm (.0001 in.) INCREMENTS is required. If a bore gauge is not available, do not use an inside micrometer.

(2) Measure the inside diameter of the cylinder bore at a point 49.5 mm (1-15/16 inches) below top of bore. Start perpendicular (across or at 90 degrees) to the axis of the crankshaft at point A and then take

SERVICE PROCEDURES (Continued)

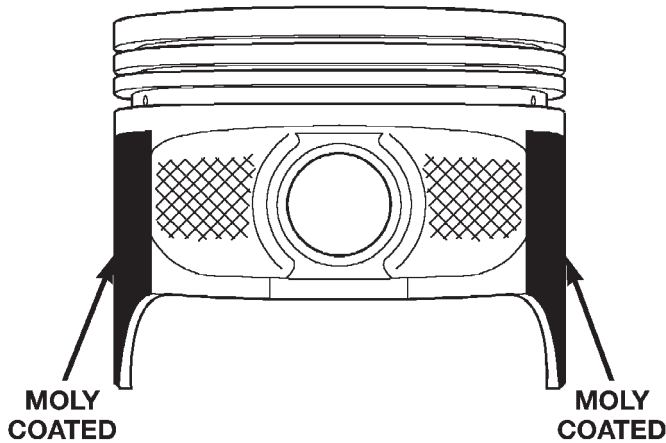
an additional bore reading 90 degrees to that at point B (Fig. 6).

(3) The coated pistons will be serviced with the piston pin and connecting rod pre-assembled. **The coated piston connecting rod assembly can be used to service previous built engines and MUST be replaced as complete sets.** Tin coated pistons should not be used as replacements for coated pistons.

(4) The coating material is applied to the piston after the final piston machining process. Measuring the outside diameter of a coated piston will not provide accurate results (Fig. 5). Therefore measuring the inside diameter of the cylinder bore with a dial Bore Gauge is **MANDATORY**. To correctly select the proper size piston, a cylinder bore gauge capable of reading in 0.003 mm (.0001 in.) increments is required.

(5) Piston installation into the cylinder bore requires slightly more pressure than that required for non-coated pistons. The bonded coating on the piston will give the appearance of a line-to-line fit with the cylinder bore.

DO NOT MEASURE MOLY COATED PISTON

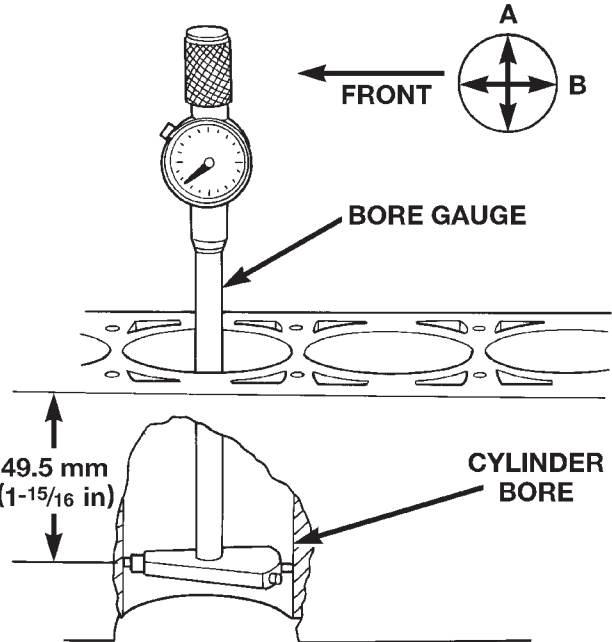


80aac2ao

Fig. 5 Moly Coated Piston

PISTON SIZE CHART

CYLINDER BORE SIZE	PISTON LETTER SIZE
98.438 to 98.448 mm (3.8755 to 3.8759 in.)	A
98.448 to 98.458 mm (3.8759 to 3.8763 in.)	B
98.458 to 98.468 mm (3.8763 to 3.8767 in.)	C
98.468 to 98.478 mm (3.8767 to 3.8771 in.)	D
98.478 to 98.488 mm (3.8771 to 3.8775 in.)	E
98.488 to 98.498 mm (3.8775 to 3.8779 in.)	F



805dd884

Fig. 6 Bore Gauge

PISTON RING FITTING

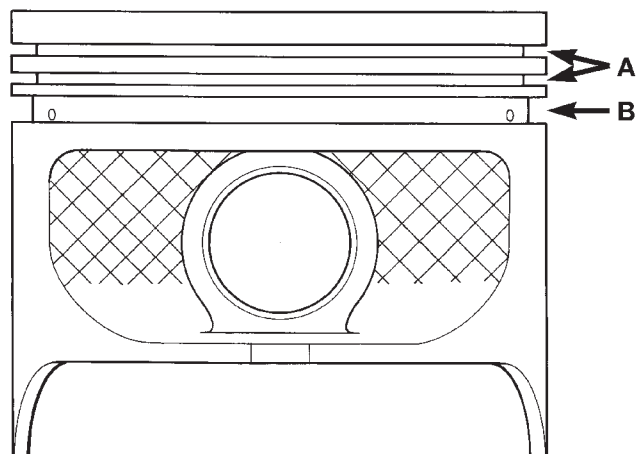
(1) Carefully clean the carbon from all ring grooves. Oil drain openings in the oil ring groove and pin boss must be clear. **DO NOT** remove metal from the grooves or lands. This will change ring-to-groove clearances and will damage the ring-to-land seating.

(2) Be sure the piston ring grooves are free of nicks and burrs.

(3) Measure the ring side clearance with a feeler gauge fitted snugly between the ring land and ring (Fig. 7) (Fig. 8). Rotate the ring in the groove. It must move freely around circumference of the groove.

GROOVE HEIGHT

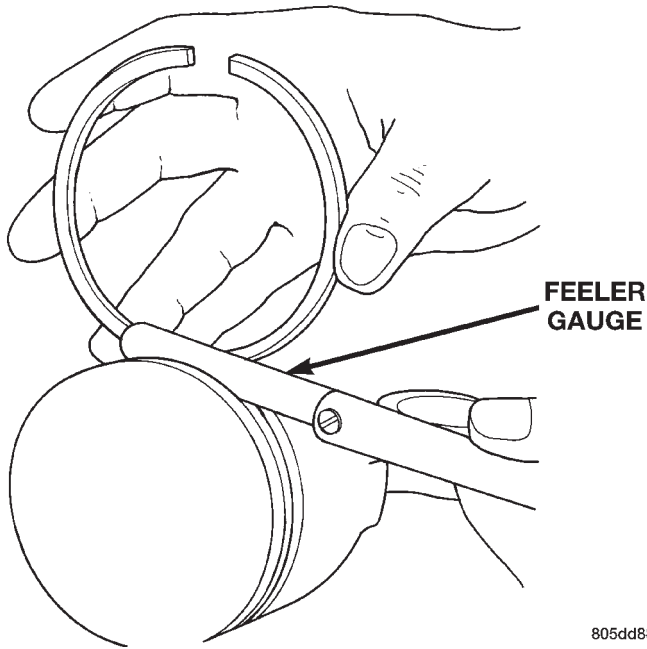
- A 1.530-1.555 mm (0.0602-0.0612 in)
- B 4.035-4.060 mm (0.1589-0.1598 in)



805dd885

Fig. 7 Piston Dimensions

SERVICE PROCEDURES (Continued)



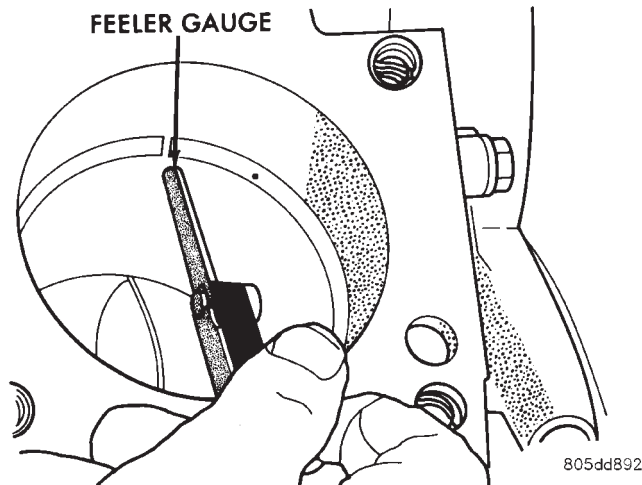
805dd887

Fig. 8 Ring Side Clearance Measurement

Ring Side Clearance Measurement

- Top Compression Ring 0.042 to 0.084 mm
(0.0017 to 0.0033 in.)
- Second Compression Ring 0.042 to 0.084 mm
(0.0017 to 0.0033 in.)
- Oil Control Ring 0.06 to 0.21 mm
(0.0024 to 0.0083 in.)

(4) Place ring in the cylinder bore and push down with inverted piston to position near lower end of the ring travel. Measure ring gap with a feeler gauge fitting snugly between ring ends (Fig. 9).



805dd892

Fig. 9 Gap Measurement

Ring Gap Measurement

- Top Compression Ring 0.229 to 0.610 mm
(0.0090 to 0.0240 inch)
- Second Compression Ring 0.483 to 0.965 mm
(0.0190 to 0.080 inch)
- Oil Control Ring 0.254 to 1.500 mm
(0.010 to 0.060 inch)

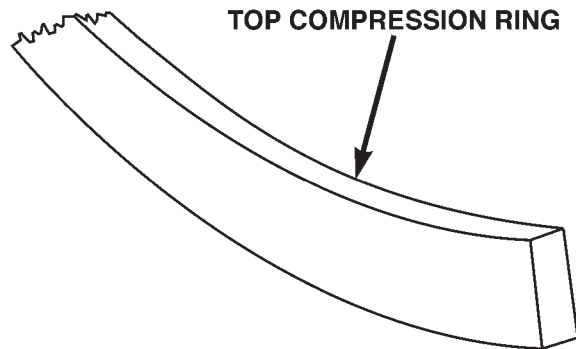
(5) The oil control rings are symmetrical, and can be installed with either side up. It is not necessary to use a tool to install the upper and lower rails. Insert oil rail spacer first, then side rails.

(6) The two compression rings are different and cannot be interchanged. The top compression ring can be identified by the shiny coating on the outer sealing surface and can be installed with either side up. (Fig. 10).

(7) The second compression ring has a slight chamfer on the bottom of the inside edge and a dot on the top for correct installation (Fig. 11).

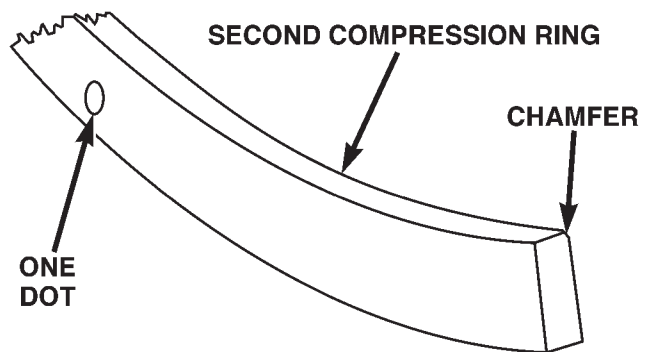
(8) Using a ring installer, install the second compression ring with the dot facing up (Fig. 11) (Fig. 13).

(9) Using a ring installer, install the top compression ring (either side up).



80a7231f

Fig. 10 Top Compression ring identification



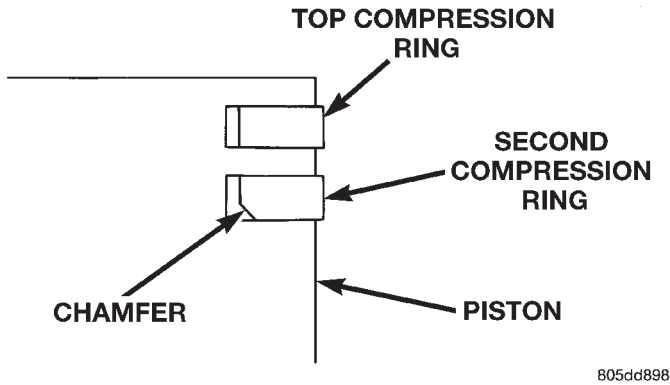
80a722da

Fig. 11 Second Compression Ring Identification

Ring Gap Orientation

- Position the gaps on the piston as shown (Fig. 14).
- Oil spacer - Gap on center line of piston skirt.

SERVICE PROCEDURES (Continued)



805dd898

Fig. 12 Compression Ring Chamfer Location

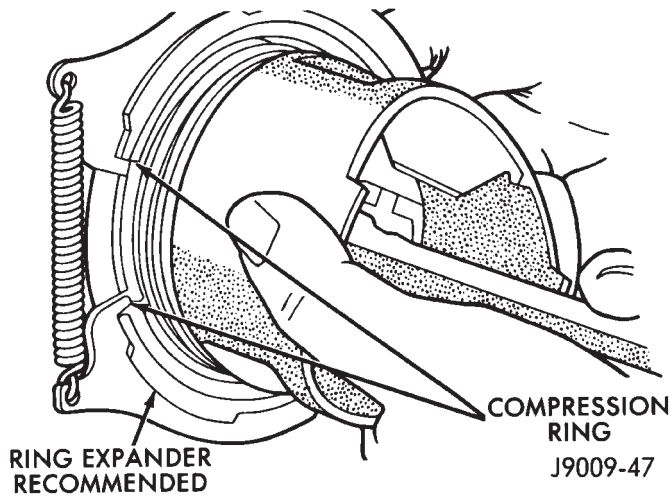


Fig. 13 Compression Ring Installation

- Oil rails - gap 180° apart on centerline of piston pin bore.
- No. 2 Compression ring - Gap 180° from top oil rail gap.
- No. 1 Compression ring - Gap 180° from No. 2 compression ring gap.

FITTING CONNECTING ROD BEARINGS

INSPECTION

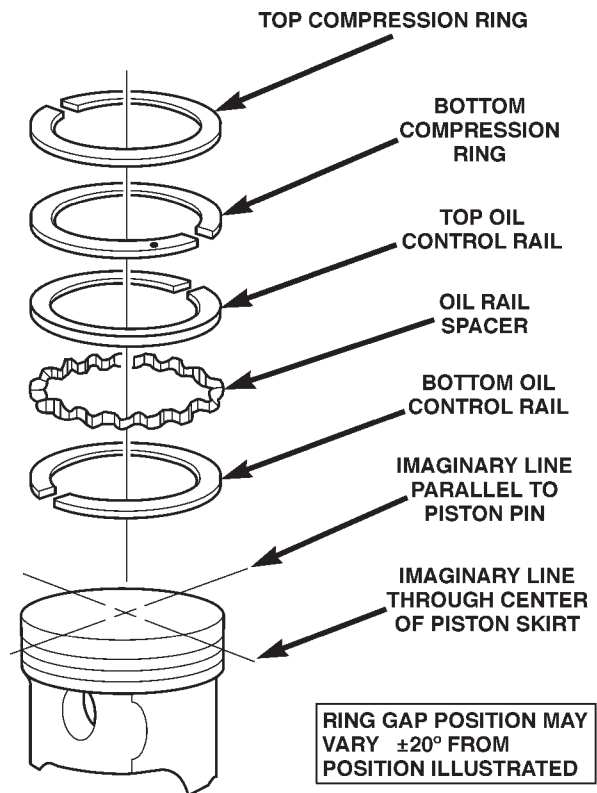
BEARINGS

Inspect the connecting rod bearings for scoring and bent alignment tabs (Fig. 15) (Fig. 16). Check the bearings for normal wear patterns, scoring, grooving, fatigue and pitting (Fig. 17). Replace any bearing that shows abnormal wear.

Inspect the connecting rod journals for signs of scoring, nicks and burrs.

CONNECTING RODS

Misaligned or bent connecting rods can cause abnormal wear on pistons, piston rings, cylinder walls, connecting rod bearings and crankshaft connecting rod journals. If wear patterns or damage to



80a72339

Fig. 14 Ring Gap Orientation

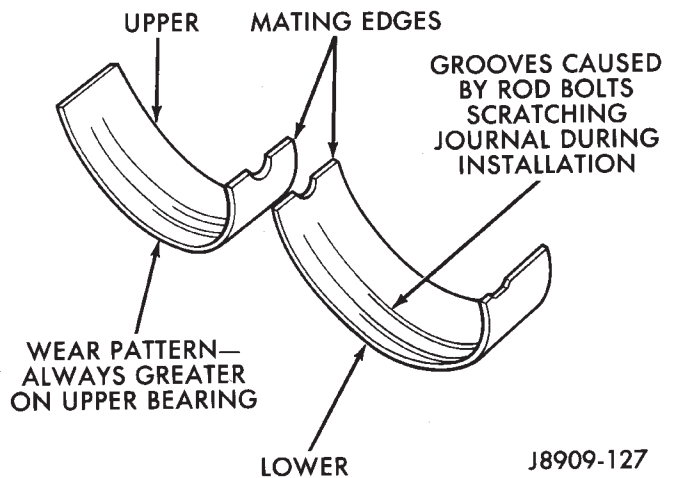


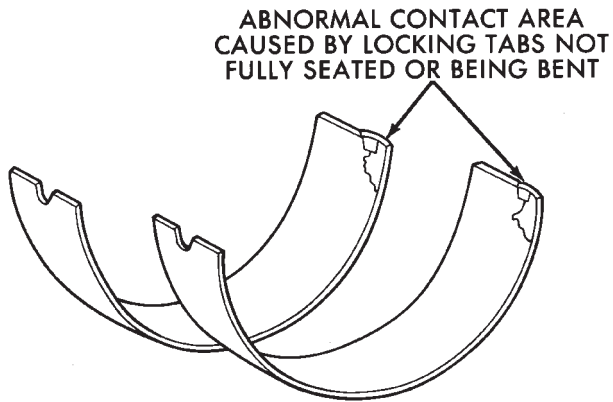
Fig. 15 Connecting Rod Bearing Inspection

any of these components indicate the probability of a misaligned connecting rod, inspect it for correct rod alignment. Replace misaligned, bent or twisted connecting rods.

BEARING-TO-JOURNAL CLEARANCE

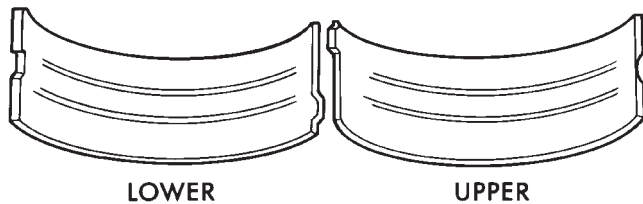
- (1) Wipe the oil from the connecting rod journal.
- (2) Use short rubber hose sections over rod bolts during installation.

SERVICE PROCEDURES (Continued)



J8909-128

Fig. 16 Locking Tab Inspection

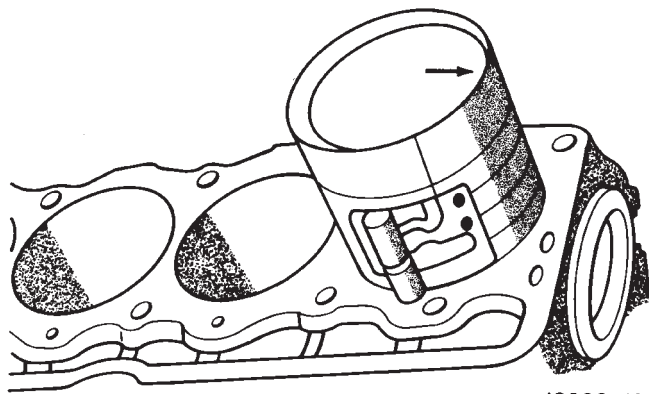


J8909-129

Fig. 17 Scoring Caused by Insufficient Lubrication or by Damaged Crankshaft Pin Journal

(3) Lubricate the upper bearing insert and install in connecting rod.

(4) Use piston ring compressor to install the rod and piston assemblies. The oil squirt holes in the rods must face the camshaft. The arrow on the piston crown should point to the front of the engine (Fig. 18). Verify that the oil squirt holes in the rods face the camshaft and that the arrows on the pistons face the front of the engine.



J9009-41

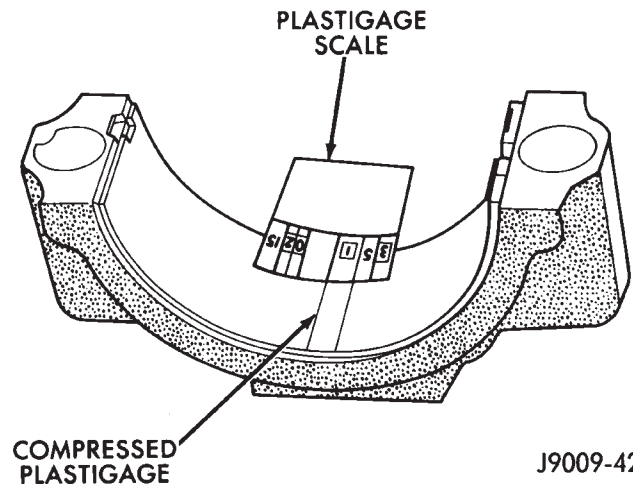
Fig. 18 Rod and Piston Assembly Installation

(5) Install the lower bearing insert in the bearing cap. The lower insert must be dry. Place strip of Plastigage across full width of the lower insert at the cen-

ter of bearing cap. Plastigage must not crumble in use. If brittle, obtain fresh stock.

(6) Install bearing cap and connecting rod on the journal and tighten nuts to 45 N·m (33 ft. lbs.) torque. DO NOT rotate crankshaft. Plastigage will smear, resulting in inaccurate indication.

(7) Remove the bearing cap and determine amount of bearing-to-journal clearance by measuring the width of compressed Plastigage (Fig. 19). Refer to Engine Specifications for the proper clearance. **Plastigage should indicate the same clearance across the entire width of the insert. If the clearance varies, it may be caused by either a tapered journal, bent connecting rod or foreign material trapped between the insert and cap or rod.**



J9009-42

Fig. 19 Measuring Bearing Clearance with Plastigage

(8) If the correct clearance is indicated, replacement of the bearing inserts is not necessary. Remove the Plastigage from crankshaft journal and bearing insert. Proceed with installation.

(9) If bearing-to-journal clearance exceeds the specification, install a pair of 0.0254 mm (0.001 inch) undersize bearing inserts. All the odd size inserts must be on the bottom. The sizes of the service replacement bearing inserts are stamped on the backs of the inserts. Measure the clearance as described in the previous steps.

(10) The clearance is measured with a pair of 0.0254 mm (0.001 inch) undersize bearing inserts installed. This will determine if two 0.0254 mm (0.001 inch) undersize inserts or another combination is needed to provide the correct clearance (refer to Connecting Rod Bearing Fitting Chart).

(11) **FOR EXAMPLE:** If the initial clearance was 0.0762 mm (0.003 inch), 0.025 mm (0.001 inch) undersize inserts would reduce the clearance by 0.025 mm (0.001 inch). The clearance would be 0.002

SERVICE PROCEDURES (Continued)**CONNECTING ROD BEARING FITTING CHART**

CRANKSHAFT JOURNAL		CORRESPONDING ROD BEARING INSERT	
Color Code	Diameter	Upper Insert Size	Lower Insert Size
Yellow	53.2257 - 53.2079 mm (2.0955 - 2.0948 in.)	Yellow - Standard	Yellow - Standard
Orange	53.2079 - 53.1901 mm (2.0948 - 2.0941 in.) 0.0178 mm (0.0007 in.) Undersize	Yellow - Standard	Blue - Undersize 0.025 mm (0.001 in.)
Blue	53.1901 - 53.1724 mm (2.0941 - 2.0934 in.) 0.0356 mm (0.0014 in.) Undersize	Blue - Undersize 0.025 mm (0.001 in.)	Blue - Undersize 0.025 mm (0.001 in.)
Red	52.9717 - 52.9539 mm (2.0855 - 2.0848 in.) 0.254 mm (0.010 in.) Undersize	Red - Undersize 0.254 mm (0.010 in.)	Red - Undersize 0.254 mm (0.010 in.)

inch and within specification. A 0.051 mm (0.002 inch) undersize insert would reduce the initial clearance an additional 0.013 mm (0.0005 inch). The clearance would then be 0.038 mm (0.0015 inch).

(12) Repeat the Plastigage measurement to verify your bearing selection prior to final assembly.

(13) Once you have selected the proper insert, install the insert and cap. Tighten the connecting rod bolts to 45 N·m (33 ft. lbs.) torque.

SIDE CLEARANCE MEASUREMENT

Slide snug-fitting feeler gauge between the connecting rod and crankshaft journal flange (Fig. 20). Refer to Engine Specifications for the proper clearance. Replace the connecting rod if the side clearance is not within specification.

FITTING CRANKSHAFT MAIN BEARINGS**INSPECTION**

Wipe the inserts clean and inspect for abnormal wear patterns and for metal or other foreign material imbedded in the lining. Normal main bearing insert wear patterns are illustrated (Fig. 21).

NOTE: If any of the crankshaft journals are scored, remove the engine for crankshaft repair.

Inspect the back of the inserts for fractures, scrapings or irregular wear patterns.

Inspect the upper insert locking tabs for damage.

Replace all damaged or worn bearing inserts.

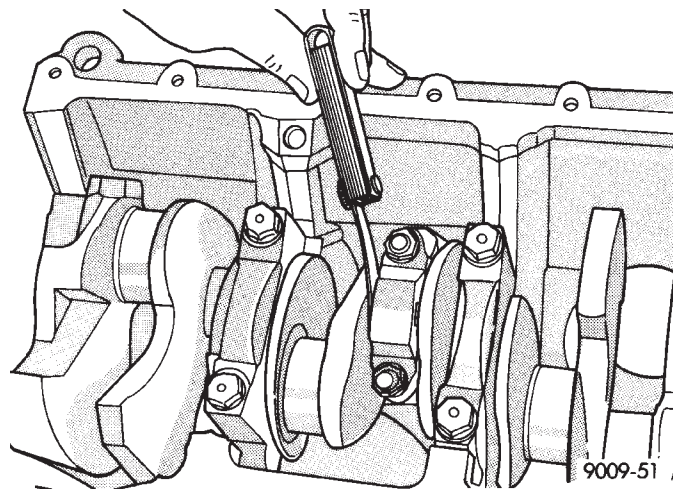


Fig. 20 Checking Connecting Rod Side Clearance—Typical

FITTING BEARINGS (CRANKSHAFT INSTALLED)

The main bearing caps, numbered (front to rear) from 1 through 7 have an arrow to indicate the forward position. The upper main bearing inserts are grooved to provide oil channels while the lower inserts are smooth.

Each bearing insert pair is selectively fitted to its respective journal to obtain the specified operating clearance. In production, the select fit is obtained by using various-sized color-coded bearing insert pairs as listed in the Main Bearing Fitting Chart. The bearing color code appears on the edge of the insert. **The size is not stamped on bearing inserts used for engine production.**

SERVICE PROCEDURES (Continued)

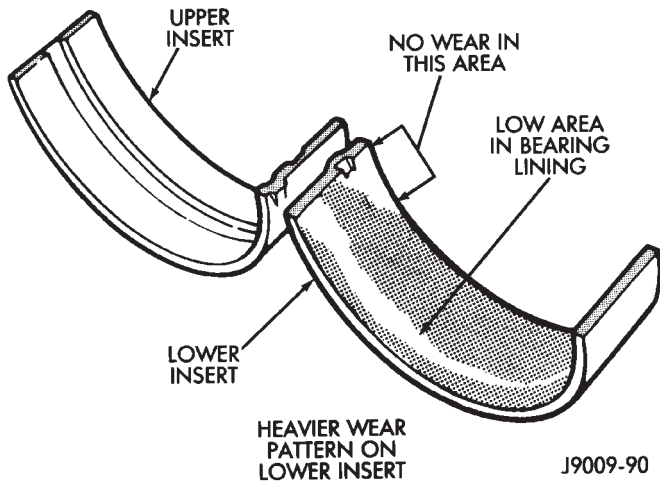


Fig. 21 Main Bearing Wear Patterns

The main bearing journal size (diameter) is identified by a color-coded paint mark (Fig. 22) on the adjacent cheek or counterweight towards the rear of the crankshaft (flange end). The rear main journal, is identified by a color-coded paint mark on the crankshaft rear flange.

When required, upper and lower bearing inserts of different sizes may be used as a pair. A standard size insert is sometimes used in combination with a 0.025 mm (0.001 inch) undersize insert to reduce the clearance by 0.013 mm (0.0005 inch). **Never use a pair of bearing inserts with greater than a 0.025 mm (0.001 inch) difference in size (Fig. 23).**

NOTE: When replacing inserts, the odd size inserts must be either all on the top (in cylinder block) or all on the bottom (in main bearing cap).

Insert	Correct	Incorrect
Upper	Standard	Standard
Lower	0.025 mm (0.001 in.) Undersize	0.051 mm (0.002 in.) Undersize

J9109-179

Fig. 23 Bearing Insert Pairs

Once the bearings have been properly fitted, proceed to Crankshaft Main Bearing—Installation.

BEARING-TO-JOURNAL CLEARANCE (CRANKSHAFT INSTALLED)

When using Plastigage, check only one bearing clearance at a time.

Install the grooved main bearings into the cylinder block and the non-grooved bearings into the bearing caps.

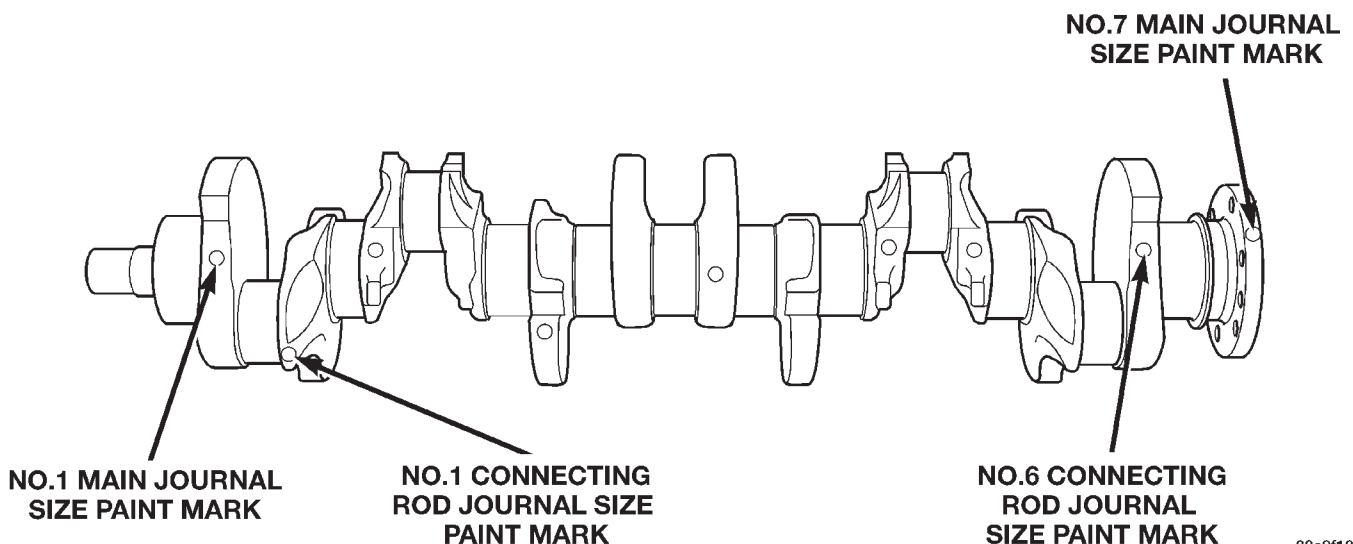
Install the crankshaft into the upper bearings dry.

Place a strip of Plastigage across full width of the crankshaft journal to be checked.

Install the bearing cap and tighten the bolts to 108 N·m (80 ft. lbs.) torque.

NOTE: DO NOT rotate the crankshaft. This will cause the Plastigage to shift, resulting in an inaccurate reading. Plastigage must not be permitted to crumble. If brittle, obtain fresh stock.

Remove the bearing cap. Determine the amount of clearance by measuring the width of the compressed



80a9f121

Fig. 22 Crankshaft Journal Size Paint I.D. Location

SERVICE PROCEDURES (Continued)

Plastigage with the scale on the Plastigage envelope (Fig. 24). Refer to Engine Specifications for the proper clearance.

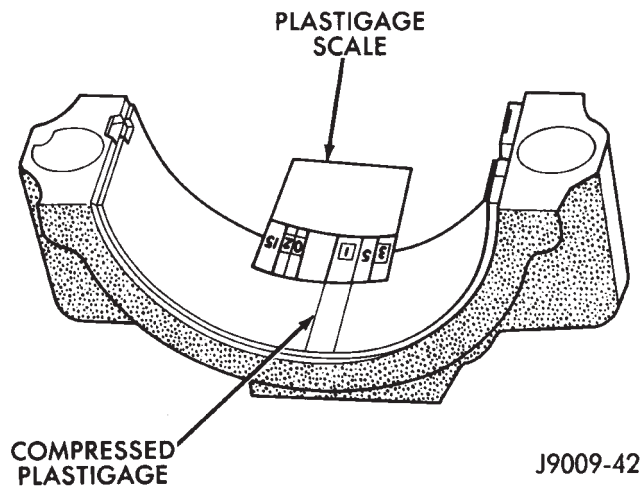


Fig. 24 Measuring Bearing Clearance with Plastigage

Plastigage should indicate the same clearance across the entire width of the insert. If clearance varies, it may indicate a tapered journal or foreign material trapped behind the insert.

If the specified clearance is indicated and there are no abnormal wear patterns, replacement of the bearing inserts is not necessary. Remove the Plastigage from the crankshaft journal and bearing insert. Proceed to Crankshaft Main Bearing—Installation.

If the clearance exceeds specification, install a pair of 0.025 mm (0.001 inch) undersize bearing inserts and measure the clearance as described in the previous steps.

The clearance indicate with the 0.025 mm (0.001 inch) undersize insert pair installed will determine if this insert size or some other combination will provide the specified clearance. **FOR EXAMPLE:** If the clearance was 0.0762 mm (0.003 inch) originally, a pair of 0.0254 mm (0.001 inch) undersize inserts would reduce the clearance by 0.0254 mm (0.001 inch). The clearance would then be 0.0508 mm (0.002

inch) and within the specification. A 0.051 mm (0.002 inch) undersize bearing insert and a 0.0254 mm (0.001 inch) undersize insert would reduce the original clearance an additional 0.0127 mm (0.0005 inch). The clearance would then be 0.0381 mm (0.0015 inch).

CAUTION: Never use a pair of inserts that differ more than one bearing size as a pair.

FOR EXAMPLE: DO NOT use a standard size upper insert and a 0.051 mm (0.002 inch) undersize lower insert.

If the clearance exceeds specification using a pair of 0.051 mm (0.002 inch) undersize bearing inserts, measure crankshaft journal diameter with a micrometer. If the journal diameter is correct, the crankshaft bore in the cylinder block may be misaligned, which requires cylinder block replacement or machining to true bore.

Replace the crankshaft or grind to accept the appropriate undersize bearing inserts if:

- Journal diameters 1 through 6 are less than 63.4517 mm (2.4981 inches)
- Journal 7 diameter is less than 63.4365 mm (2.4975 inches).

Once the proper clearances have been obtained, proceed to Crankshaft Main Bearing—Installation.

MAIN BEARING JOURNAL DIAMETER (CRANKSHAFT REMOVED)

Remove the crankshaft from the cylinder block (refer to Cylinder Block - Disassemble).

Clean the oil off the main bearing journal.

Determine the maximum diameter of the journal with a micrometer. Measure at two locations 90° apart at each end of the journal.

The maximum allowable taper and out of round is 0.013 mm (0.0005 inch). Compare the measured diameter with the journal diameter specification (Main Bearing Fitting Chart). Select inserts required to obtain the specified bearing-to-journal clearance.

Install the crankshaft into the cylinder block (refer to Cylinder Block - Assemble and Crankshaft Main Bearings - Installation).

SERVICE PROCEDURES (Continued)

MAIN BEARING FITTING CHART

Crankshaft Journals #1-6		Corresponding Crankshaft Bearing Insert	
Color Code	Diameter	Upper Insert Size	Lower Insert Size
Yellow	63.5025 - 63.4898 mm	Yellow - Standard	Yellow - Standard
	(2.5001 - 2.4996 in.)		
Orange	63.4898 - 63.4771 mm	Yellow - Standard	Blue - Undersize 0.025 mm (0.001 in.)
	(2.4996 - 2.4991 in.)		
	0.0127 mm (0.0015 in.) Undersize		
Blue	63.4771 - 63.4644 mm	Blue - Undersize 0.025 mm (0.001 in.)	Blue - Undersize 0.025 mm (0.001 in.)
	(2.4991 - 2.4986 in.)		
	0.0254 mm (0.001 in.) Undersize		
Green	63.4644 - 63.4517 mm	Blue - Undersize 0.025 mm (0.001 in.)	Green - Undersize 0.051 mm (0.002 in.)
	(2.4986 - 2.4981 in.)		
	0.0381 mm (0.0015 in.) Undersize		
Red	63.2485 - 63.2358 mm	Red - Undersize 0.254 mm (0.010 in.)	Red - Undersize 0.254 mm (0.010 in.)
	(2.4901 - 2.4896 in.)		
	0.254 mm (0.010 in.) Undersize		

Crankshaft Journal #7 Only		Corresponding Bearing Insert	
Color Code	Diameter	Upper Insert Size	Lower Insert Size
Yellow	63.4873 - 63.4746 mm (2.4995 - 2.4990 in.)	Yellow - Standard	Yellow - Standard
Orange	63.4746 - 63.4619 mm (2.4996 - 2.4991 in.) 0.0127 mm (0.0005 in.) Undersize	Yellow - Standard	Blue - Undersize 0.025 mm (0.001 in.)
Blue	63.4619 - 63.4492 mm (2.4985 - 2.4980 in.) 0.0254 mm (0.001 in.) Undersize	Blue - Undersize 0.025 mm (0.001 in.)	Blue - Undersize 0.025 mm (0.001 in.)
Green	63.4492 - 63.4365 mm (2.4980 - 2.4975 in.) 0.0381 mm (0.0015 in.) Undersize	Blue - Undersize 0.025 mm (0.001 in.)	Green - Undersize 0.051 mm (0.002 in.)
Red	63.2333 - 63.2206 mm (2.4895 - 2.4890 in.) 0.254 mm (0.010 in.) Undersize	Red - Undersize 0.254 mm (0.010 in.)	Red - Undersize 0.254 mm (0.010 in.)

REMOVAL AND INSTALLATION

ENGINE MOUNTS—FRONT

The front mounts support the engine at each side. These insulators are made of resilient rubber.

REMOVAL

- (1) Disconnect the negative cable from the battery.
- (2) Support the engine.
- (3) Raise the vehicle.
- (4) Remove the insulator assembly-to-lower front sill bolts (Fig. 25) (Fig. 26).
- (5) Raise the engine slightly.
- (6) Remove the thru-bolt nut and thru-bolt (Fig. 25) (Fig. 26). Remove the insulator.

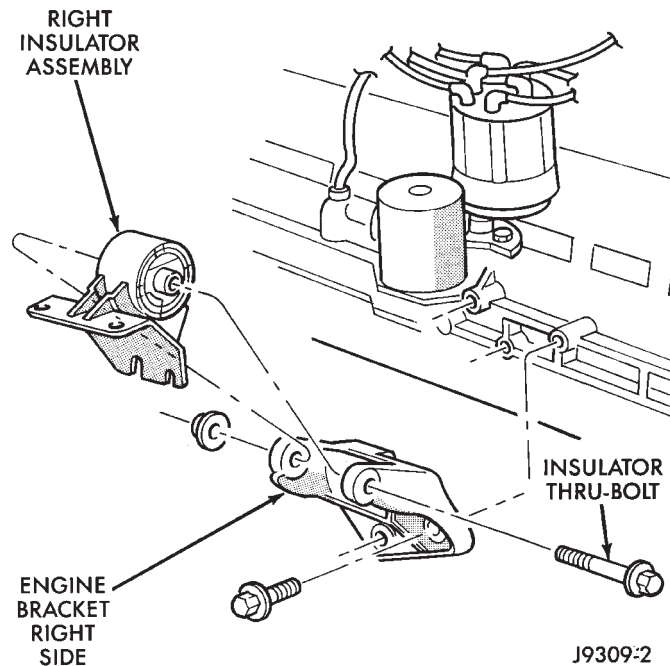


Fig. 25 Front Engine Mount—Right Side

- (7) If required, remove the engine bracket from the block (Fig. 25) (Fig. 26).

INSTALLATION

- (1) If removed, install the engine bracket to the block (Fig. 25) (Fig. 26). Tighten the bolts to 61 N·m (45 ft. lbs.) torque.
- (2) Install the insulator assembly to the lower front sill. Tighten the bolts to 65 N·m (48 ft. lbs.) torque.
- (3) With the engine insulator assembly and engine bracket in position, install the thru-bolt and nut (Fig. 25) (Fig. 26). Tighten the thru-bolt nut to 121 N·m (89 ft. lbs.) torque.
- (4) Lower the vehicle.
- (5) Remove the engine support.
- (6) Connect the negative cable to the battery.

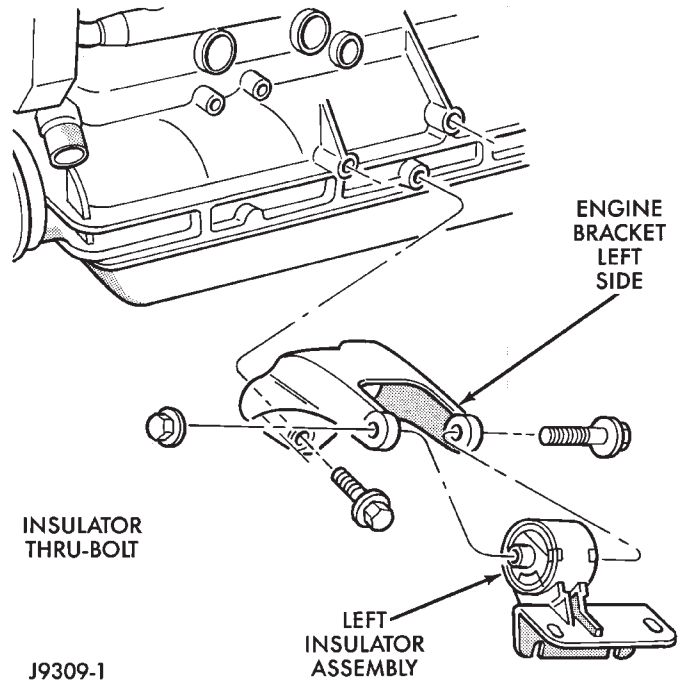


Fig. 26 Front Engine Mount—Left Side

ENGINE MOUNT—REAR

A resilient rubber cushion bracket assembly supports the transmission at the rear. This bracket is attached to the crossmember (Fig. 27) (Fig. 28).

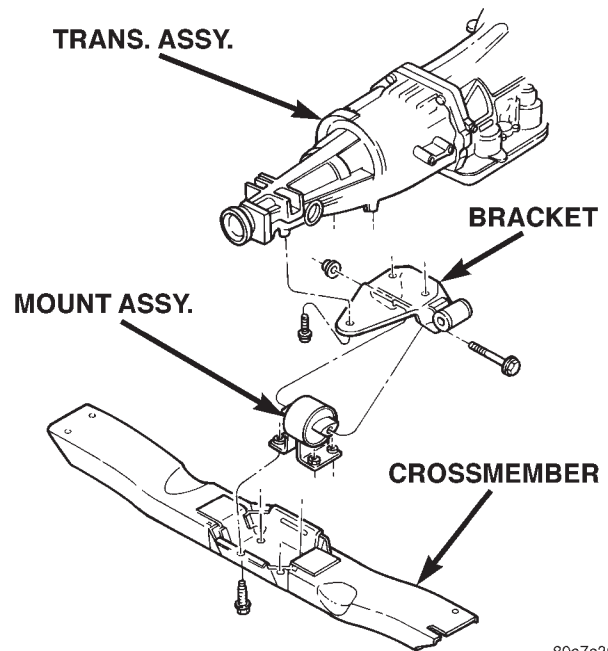
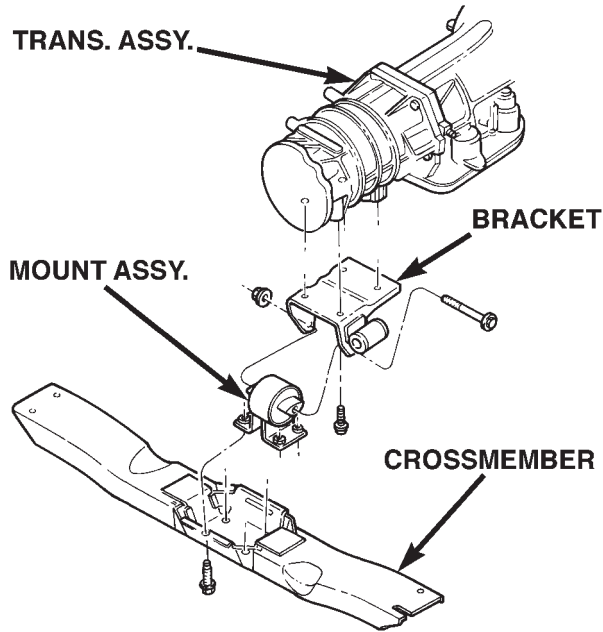


Fig. 27 Rear Engine Mount—(4x2)

REMOVAL

- (1) Disconnect the negative cable from the battery.
- (2) Raise the vehicle and support the transmission.
- (3) Remove the bolts holding the mount assy. to the crossmember.

REMOVAL AND INSTALLATION (Continued)



80a7e302

Fig. 28 Rear Engine Mount—(4x4)

- (4) Raise the transmission SLIGHTLY.
- (5) Remove the thru-bolt and nut. Remove the rear mount assy (Fig. 27) (Fig. 28).
- (6) If necessary, remove the bolts holding the rear mount bracket to the transmission. Remove the bracket from the exhaust pipe hanger. Remove the bracket.

INSTALLATION

- (1) Position the rear mount bracket onto the exhaust hanger (if previously removed). Position the rear mount bracket assembly onto the transmission and install the bolts. Tighten the bolts to 46 N·m (34 ft. lbs.)
- (2) Position mount into mount bracket and install thru-bolt and nut. DO NOT tighten the bolt at this time.
- (3) Lower the transmission until the mount fastening studs are in position in the crossmember.
- (4) Remove the transmission support.
- (5) Install the mount fastening nuts and tighten the nuts to 54 N·m (40 ft. lbs.) torque.
- (6) Tighten the thru-bolt nut to 65 N·m (48 ft. lbs.) torque.
- (7) Lower the vehicle.
- (8) Connect the negative cable to the battery.

ENGINE ASSEMBLY

REMOVAL

- (1) Disconnect the battery negative cable.

(2) Mark the hinge locations on the hood panel for alignment reference during installation. Remove the engine compartment lamp. Remove the hood.

(3) Remove the radiator drain cock and radiator cap to drain the coolant. DO NOT waste usable coolant. If the solution is clean, drain the coolant into a clean container for reuse.

(4) Remove the upper radiator hose and coolant recovery hose (Fig. 29).

(5) Remove the lower radiator hose.

(6) Remove upper radiator support retaining bolts and remove radiator support.

(7) Remove the fan assembly from the water pump.

(8) Remove the fan shroud (Fig. 29).

(9) Disconnect the transmission fluid cooler lines (automatic transmission).

(10) Discharge the A/C system. (Refer to Group 24, Heating and Air Conditioning)

(11) Remove the service valves and cap the compressor ports.

(12) Remove the radiator or radiator/condenser (if equipped with A/C).

(13) Disconnect the heater hoses at the engine thermostat housing and water pump (Fig. 29).

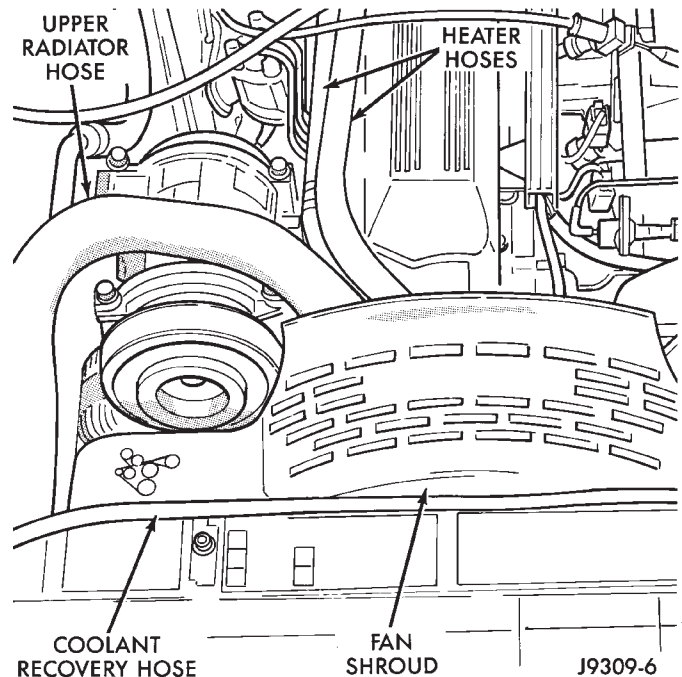


Fig. 29 Upper Radiator Hose, Coolant Recovery Hose, Fan Shroud & Heater hoses

(14) Disconnect the accelerator cable, transmission line pressure cable and speed control cable (if equipped) from the throttle body (Fig. 30).

(15) Remove cables from the bracket and secure out of the way.

(16) Disconnect the body ground at the engine.

REMOVAL AND INSTALLATION (Continued)

(17) Disconnect the following connectors and secure their harness out of the way.

- Power steering pressure switch
- Coolant temperature sensor
- Six (6) fuel injector connectors
- Intake air temperature sensor
- Throttle position sensor
- Map sensor
- Crankshaft position sensor
- Oxygen sensor

(18) Disconnect the distributor electrical connection and the oil pressure switch connector.

(19) Perform the fuel pressure release procedure. (Refer to Group 14, Fuel System for correct procedure)

(20) Disconnect the fuel supply line at the injector rail. (Refer to Group 14, Quick-Connect Fittings for the correct procedure)

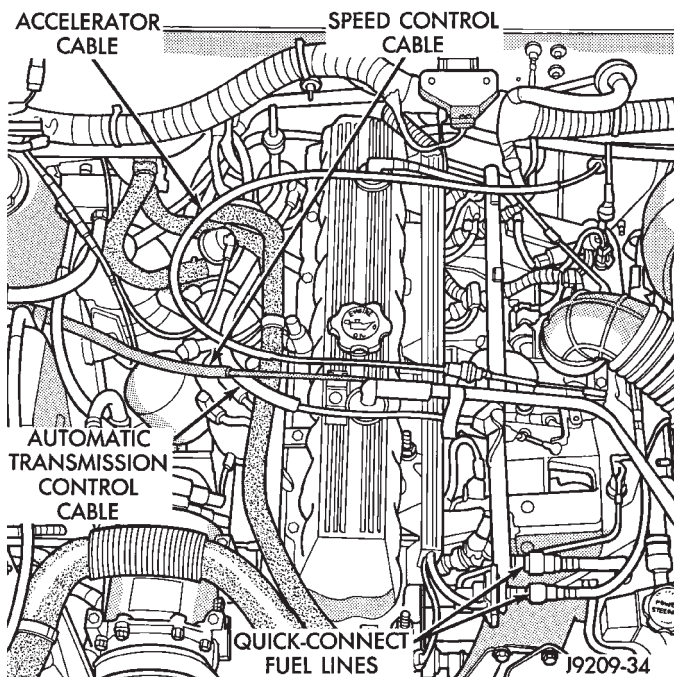


Fig. 30 Accelerator Cable, Vehicle Speed Control Cable, Automatic Transmission Control Cable & Quick-Connect Fuel Lines

(21) Remove the fuel line bracket from the intake manifold.

(22) Remove the air cleaner assembly (Fig. 31).

(23) Disconnect the hoses from the fittings at the steering gear.

(24) Drain the pump reservoir.

(25) Cap the fittings on the hoses and steering gear to prevent foreign objects from entering the system.

(26) Raise and support the vehicle.

(27) Disconnect the wires from the engine starter motor solenoid.

(28) Remove the engine starter motor.

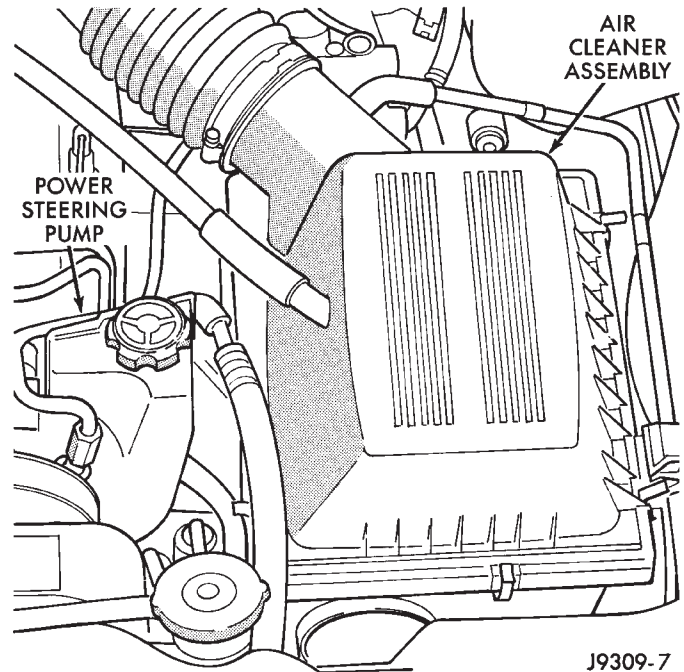


Fig. 31 Air Cleaner Assembly & Power Steering Pump

(29) Disconnect the oxygen sensor from the exhaust pipe.

(30) Disconnect the exhaust pipe from the manifold. Discard the seal.

(31) Remove the exhaust pipe support.

(32) Remove the engine flywheel/converter housing access cover.

(33) Mark the converter and drive plate location.

(34) Remove the converter-to-drive plate bolts.

(35) Remove the upper engine flywheel/converter housing bolts and loosen the bottom bolts.

(36) Remove the engine mount cushion-to-engine compartment bracket bolts.

(37) Lower the vehicle.

(38) Attach a lifting device to the engine.

(39) Raise the engine off the front supports.

(40) Place a support or floor jack under the converter (or engine flywheel) housing.

(41) Remove the remaining converter (or engine flywheel) housing bolts.

(42) Lift the engine out of the engine compartment.

INSTALLATION

CAUTION: When installing the engine into a vehicle equipped with an automatic transmission, be careful not to damage the trigger wheel on the engine flywheel.

(1) Attach a lifting device to the engine and lower the engine into the engine compartment. For easier installation, it may be necessary to remove the

REMOVAL AND INSTALLATION (Continued)

engine mount bracket as an aid in alignment of the engine to the transmission.

(2) Align the transmission torque converter housing with the engine.

(3) Loosely install the converter housing lower bolts and install the next higher bolt and nut on each side.

(4) Tighten all 4 bolts finger tight.

(5) Install the engine mount brackets (if removed).

(6) Lower the engine and engine mount brackets onto the engine compartment cushions. Install the bolts and finger tighten the nuts.

(7) Remove the engine lifting device.

(8) Raise and support the vehicle.

(9) Install the remaining engine flywheel/converter housing bolts. Tighten all bolts to 38 N·m (28 ft. lbs.) torque.

(10) Install the converter-to-drive plate bolts.

(11) Ensure the installation reference marks are aligned.

(12) Install the engine flywheel/converter housing access cover.

(13) Install the exhaust pipe support and tighten the screw.

(14) Tighten the engine mount-to-bracket bolts.

(15) Connect the vehicle speed sensor wire connections and tighten the screws.

(16) Connect the exhaust pipe to the manifold.

(17) Install the engine starter motor and connect the cable.

(18) Connect the wires to the engine starter motor solenoid.

(19) Lower the vehicle.

(20) Connect all the vacuum hoses and wire connectors identified during engine removal.

(21) Remove protective caps from the power steering hoses.

(22) Connect the hoses to the fittings at the steering gear. Tighten the nut to 52 N·m (38 ft. lbs.) torque.

(23) Fill the pump reservoir with fluid.

(24) Inspect the fuel supply line o-ring(s) and replace if necessary. Connect fuel supply line to injector rail and verify connection by pulling outward on the line.

(25) Install the fuel line bracket to the intake manifold.

(26) Connect the distributor electrical connector and oil pressure switch connector.

(27) Connect the following electrical connectors:

- Power steering pressure switch
- Coolant temperature sensor
- Six (6) fuel injector connectors
- Intake air temperature sensor
- Throttle position sensor
- Map sensor

- Crankshaft position sensor

- Oxygen sensor

(28) Connect all previously removed vacuum hoses.

(29) Connect the body ground strap.

(30) Install the throttle, transmission line pressure, and speed control cables to their mounting bracket and connect them to the throttle body.

(31) Connect the heater hoses at the engine thermostat housing and water pump.

(32) Install the fan assembly to the water pump.

(33) Place the fan shroud in position over the fan.

(34) Install the radiator or radiator/condenser.

(35) Connect the service valves to the A/C compressor ports, if equipped with A/C.

(36) Charge the air conditioner system (refer to Group 24, Heating and Air Conditioning).

(37) Connect the radiator hoses and automatic transmission fluid cooler pipes, if equipped.

(38) Install the fan shroud to the radiator or radiator/condenser (if equipped with A/C).

(39) Install upper radiator support.

(40) Connect the upper radiator hose and tighten the clamp.

(41) Connect the lower radiator hose and tighten the clamp.

(42) Fill crankcase with engine oil. (Refer to Group 0, Lubrication and Maintenance for correct capacities.)

(43) Fill the cooling system with reusable coolant or new coolant (refer to Group 7, Cooling System).

(44) Align the hood to the scribe marks. Install the hood.

(45) Install the air cleaner assembly.

(46) Install the battery and connect the battery cable.

WARNING: USE EXTREME CAUTION WHEN THE ENGINE IS OPERATING. DO NOT STAND IN A DIRECT LINE WITH THE FAN. DO NOT PUT YOUR HANDS NEAR THE PULLEYS, BELTS OR FAN. DO NOT WEAR LOOSE CLOTHING.

(47) Start the engine, inspect for leaks and correct the fluid levels, as necessary.

CYLINDER HEAD COVER

The cylinder head cover is isolated from the cylinder head via grommets and a reusable molded rubber gasket. The grommet and limiter are retained in the cylinder head cover.

There are two cylinder head bolts that have a pin to locate the cylinder head cover gasket, they are located at position 8 and 9 (Fig. 33)

REMOVAL

(1) Disconnect negative cable from battery.

REMOVAL AND INSTALLATION (Continued)

(2) Disconnect the Crankcase Ventilation (CCV) vacuum hose from engine cylinder head cover.

(3) Disconnect the fresh air inlet hose from the engine cylinder head cover.

(4) Disconnect the accelerator, transmission, and speed (if equipped) control cables from the throttle body (Fig. 32).

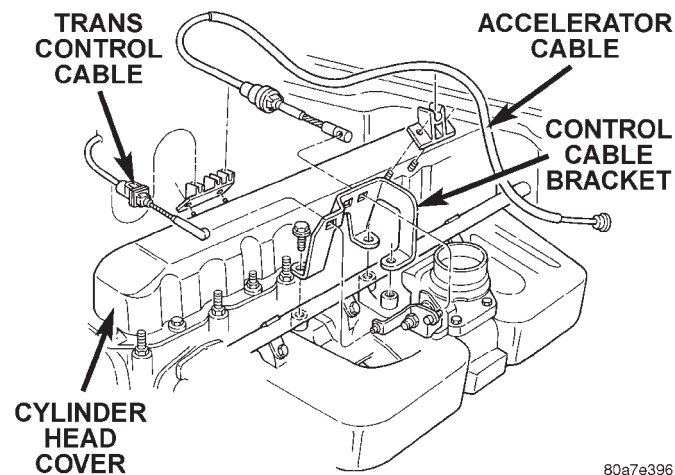
(5) Remove the three bolts that fasten the control cable bracket to the intake manifold.

(6) Remove control cables from cylinder head cover clip.

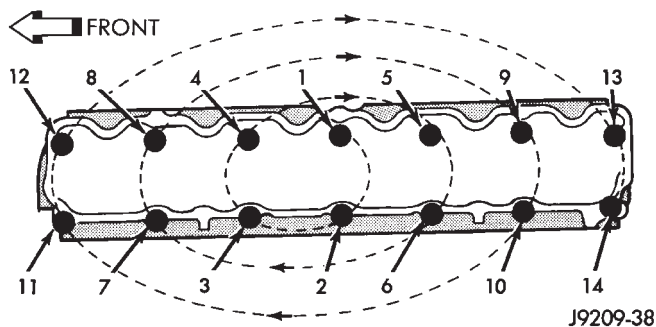
(7) Position control cables and bracket away from cylinder head cover secure with tie straps.

(8) Remove the engine cylinder head cover mounting bolts.

(9) Remove the engine cylinder head cover and gasket.



80a7e396

Fig. 32 Engine Cylinder Head Cover

J9209-38

Fig. 33 Cylinder Head Cover Gasket Locator Pins at #8 & #9**INSTALLATION**

(1) If a replacement cover is installed, transfer the CCV valve grommet and oil filler cap from the original cover to the replacement cover.

(2) Install cylinder head cover and gasket. Tighten the mounting bolts to 10 N-m (85 in. lbs.) torque.

(3) Connect the CCV hoses.

(4) Install control cables and bracket on intake manifold and tighten bolts to 8.7 N-m (77 in. lbs.) torque.

(5) Connect control cables to throttle body linkage.

(6) Snap control cables into cylinder head cover clip.

(7) Connect negative cable to battery.

ROCKER ARMS AND PUSH RODS

This procedure can be done with the engine in or out of the vehicle.

REMOVAL

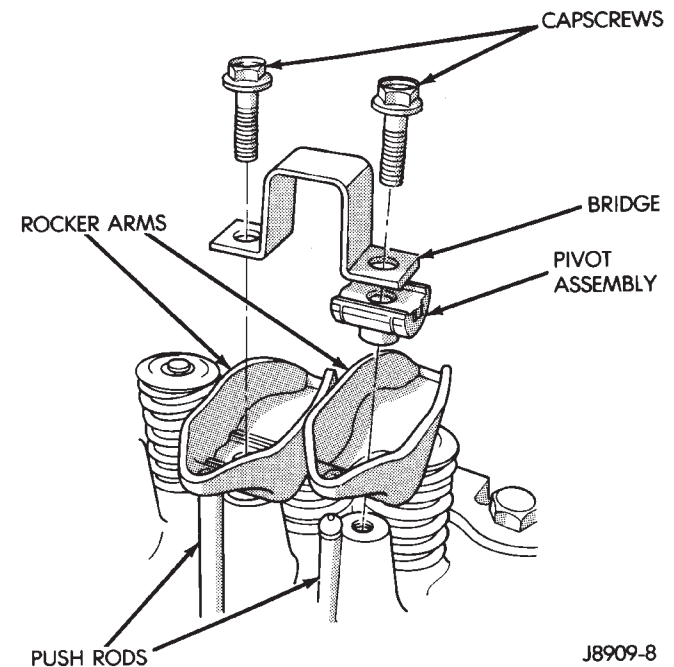
(1) Remove the engine cylinder head cover.

(2) Check for rocker arm bridges which are causing misalignment of the rocker arm to valve tip area.

(3) Remove the capscrews at each bridge and pivot assembly (Fig. 34). Alternately loosen the capscrews one turn at a time to avoid damaging the bridges.

(4) Remove the bridges, pivots and corresponding pairs of rocker arms (Fig. 34). Place them on a bench in the same order as removed.

(5) Remove the push rods and place them on a bench in the same order as removed.



J8909-8

Fig. 34 Rocker Arm Assembly**INSTALLATION**

(1) Lubricate the ball ends of the push rods with Mopar Engine Oil Supplement, or equivalent and install push rods in their original locations. Ensure that the bottom end of each push rod is centered in the tappet plunger cap seat.

(2) Using Mopar Engine Oil Supplement, or equivalent, lubricate the area of the rocker arm that the

REMOVAL AND INSTALLATION (Continued)

pivot contacts. Install rocker arms, pivots and bridge above each cylinder in their originally position.

(3) Loosely install the capscrews through each bridge.

(4) At each bridge, tighten the capscrews alternately, one turn at a time, to avoid damaging the bridge. Tighten the capscrews to 28 N·m (21 ft. lbs.) torque.

(5) Install the engine cylinder head cover.

VALVE STEM SEAL AND SPRING

This procedure can be done with the engine cylinder head installed on the block.

REMOVAL

Inspect the valve stems, especially the grooves. An Arkansas smooth stone should be used to remove nicks and high spots.

Each valve spring is held in place by a retainer and a set of conical valve locks. The locks can be removed only by compressing the valve spring.

(1) Remove the engine cylinder head cover.

(2) Remove capscrews, bridge and pivot assemblies and rocker arms for access to each valve spring to be removed.

(3) Remove push rods. **Retain the push rods, bridges, pivots and rocker arms in the same order and position as removed.**

(4) Inspect the springs and retainer for cracks and possible signs of weakening.

(5) Remove the spark plug(s) adjacent to the cylinder(s) below the valve springs to be removed.

(6) Connect an air hose to the adapter and apply air pressure slowly. Maintain at least 621 kPa (90 psi) of air pressure in the cylinder to hold the valves against their seats. For vehicles equipped with an air conditioner, use a flexible air adaptor when servicing the No.1 cylinder.

(7) Tap the retainer or tip with a rawhide hammer to loosen the lock from the retainer. Use Valve Spring Compressor Tool MD-998772A to compress the spring and remove the locks (Fig. 35).

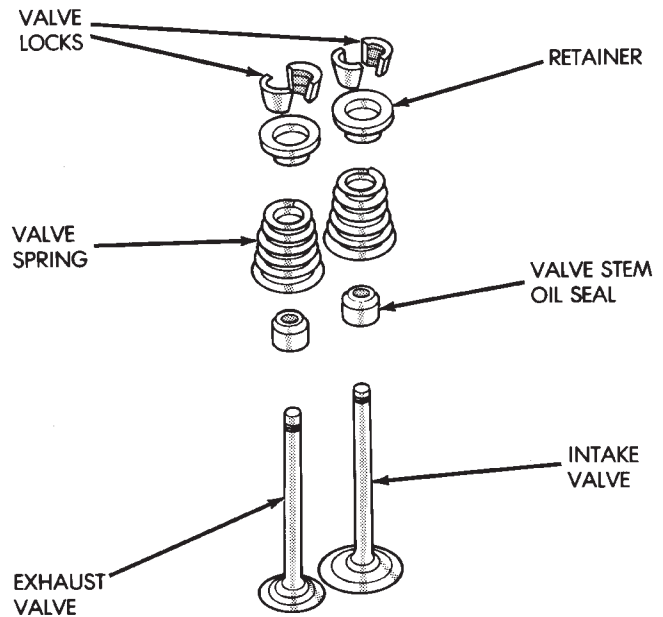
(8) Remove valve spring and retainer (Fig. 35).

(9) Remove valve stem oil seals (Fig. 35). Note the valve seals are different for intake and exhaust valves. The top of each seal is marked either INT (Intake) or EXH (Exhaust). DO NOT mix the seals.

INSTALLATION

CAUTION: Install oil seals carefully to prevent damage from the sharp edges of the valve spring lock groove.

(1) Lightly push the valve seal over the valve stem and valve guide boss. Be sure the seal is completely seated on the valve guide boss.



J8909-88

Fig. 35 Valve and Valve Components

(2) Install valve spring and retainer.

(3) Compress the valve spring with Valve Spring Compressor Tool MD-998772A and insert the valve locks. Release the spring tension and remove the tool. Tap the spring from side-to-side to ensure that the spring is seated properly on the engine cylinder head.

(4) Release air pressure and disconnect the air hose. Remove the adaptor from the spark plug hole and install the spark plug.

(5) Repeat the procedures for each remaining valve spring to be removed.

(6) Install the push rods. Ensure the bottom end of each rod is centered in the plunger cap seat of the hydraulic valve tappet.

(7) Install the rocker arms, pivots and bridge at their original location.

(8) Tighten the bridge capscrews alternately, one at a time, to avoid damaging the bridge. Tighten the capscrews to 28 N·m (21 ft. lbs.) torque.

(9) Install the engine cylinder head cover.

CYLINDER HEAD

This procedure can be done with the engine in or out of the vehicle.

REMOVAL

(1) Disconnect the battery negative cable.

WARNING: DO NOT REMOVE THE CYLINDER BLOCK DRAIN PLUGS OR LOOSEN THE RADIATOR DRAIN COCK WITH THE SYSTEM HOT AND PRESSURIZED BECAUSE SERIOUS BURNS FROM THE COOLANT CAN OCCUR.

REMOVAL AND INSTALLATION (Continued)

(2) Drain the coolant and disconnect the hoses at the engine thermostat housing and the water pump inlet. **DO NOT** waste reusable coolant. If the solution is clean and is being drained only to service the engine or cooling system, drain the coolant into a clean container for reuse.

(3) Remove the air cleaner assembly.

(4) Remove the engine cylinder head cover.

(5) Remove the capscrews, bridge and pivot assemblies and rocker arms.

(6) Remove the push rods. **Retain the push rods, bridges, pivots and rocker arms in the same order as removed.**

(7) Loosen the accessory drive belt at the power steering pump. (Refer to Group 7, Cooling System for the correct procedure). Slip the belt off of the power steering pulley.

(8) Remove the air conditioning compressor mounting bolts and secure the compressor to the side.

(9) Remove the power steering pump and bracket from the intake manifold and water pump. Set the pump and bracket aside. **DO NOT** disconnect the hoses.

(10) Perform the Fuel System Pressure Release procedure. (Refer to Group 14, Fuel System)

(11) Disconnect the fuel supply line at the fuel rail. (Refer to Group 14, Quick-Connect Fittings for the correct procedures)

(12) Remove the intake and engine exhaust manifolds from the engine cylinder head. (Refer to Group 11, Exhaust System and Intake Manifold for the proper procedures)

(13) Disconnect the ignition wires and remove the spark plugs.

(14) Disconnect the temperature sending unit wire connector.

(15) Remove the ignition coil and bracket assembly.

(16) Remove the engine cylinder head bolts. Bolt No.14 cannot be removed until the head is moved forward (Fig. 36). Pull bolt No.14 out as far as it will go and then suspend the bolt in this position (tape around the bolt).

(17) Remove the engine cylinder head and gasket (Fig. 36).

(18) If this was the first time the bolts were removed, put a paint dab on the top of the bolt. If the bolts have a paint dab on the top of the bolt or it isn't known if they were used before, discard the bolts.

(19) Stuff clean lint free shop towels into the cylinder bores.

INSTALLATION

The engine cylinder head gasket is a composition gasket. The gasket is to be installed **DRY**. **DO NOT** use a gasket sealing compound on the gasket.

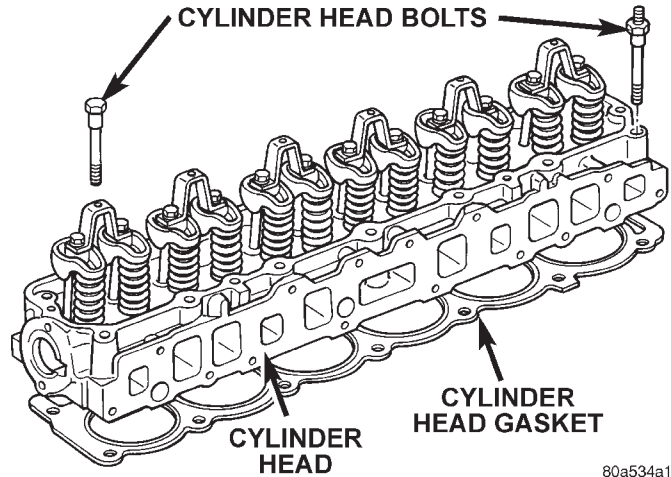


Fig. 36 Engine Cylinder Head Assembly

If the engine cylinder head is to be replaced and the original valves used, measure the valve stem diameter. Only standard size valves can be used with a service replacement engine cylinder head unless the replacement head valve stem guide bores are reamed to accommodate oversize valve stems. Remove all carbon buildup and reface the valves.

(1) Remove the shop towels from the cylinder bores. Coat the bores with clean engine oil.

(2) Position the engine cylinder head gasket (with the numbers facing up) using the alignment dowels in the cylinder block, to position the gasket.

CAUTION: Engine cylinder head bolts should be reused only once. Replace the head bolts if they were used before or if they have a paint dab on the top of the bolt.

(3) With bolt No.14 held in place (tape around bolt), install the engine cylinder head over the same dowels used to locate the gasket. Remove the tape from bolt No.14.

(4) Coat the threads of stud bolt No.11 with Loctite 592 sealant, or equivalent.

(5) Tighten the engine cylinder head bolts in sequence according to the following procedure (Fig. 37).

CAUTION: During the final tightening sequence, bolt No.11 will be tightened to a lower torque than the rest of the bolts. DO NOT overtighten bolt No.11.

(a) Tighten all bolts in sequence (1 through 14) to 30 N·m (22 ft. lbs.) torque.

(b) Tighten all bolts in sequence (1 through 14) to 61 N·m (45 ft. lbs.) torque.

(c) Check all bolts to verify they are set to 61 N·m (45 ft. lbs.) torque.

REMOVAL AND INSTALLATION (Continued)

- (d) Tighten bolts in sequence:
 - Bolts 1 through 10 to 149 N·m (110 ft. lbs.) torque.
 - Bolt 11 to 13 N·m (100 ft. lbs.) torque.
 - Bolts 12 through 14 to 149 N·m (110 ft. lbs.) torque.

CYLINDER HEAD BOLTS

POSITION	DESCRIPTION
1,4,5,12,13	1/2 in.-13 BOLT
8,9	1/2 in.-13 BOLT WITH DOWEL POINT
2,3,6,7,10,11,14	1/2 in.-13 WITH 7/16 in.-14 STUD END
All bolts are 12 point drives for rocker cover clearance	

- (e) Check all bolts in sequence to verify the correct torque.
- (f) If not already done, clean and mark each bolt with a dab of paint after tightening. Should you encounter bolts which were painted in an earlier service operation, replace them.

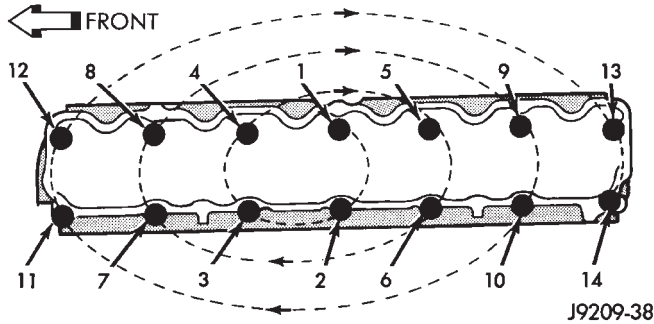


Fig. 37 Engine Cylinder Head Bolt Tightening Sequence

- (6) Install the ignition coil and bracket assembly.
- (7) Connect the temperature sending unit wire connector.
- (8) Install the spark plugs and tighten to 37 N·m (27 ft. lbs.) torque. Connect the ignition wires.
- (9) Install the intake and engine exhaust manifolds (refer to Group 11, Exhaust System and Intake Manifold for the proper procedures).
- (10) Install the fuel lines and the vacuum advance hose.
- (11) If equipped, attach the power steering pump and bracket.
- (12) Install the push rods, rocker arms, pivots and bridges in the order they were removed (refer to Rocker Arms and Push Rods in this section).
- (13) Install the engine cylinder head cover.
- (14) Attach the air conditioner compressor mounting bracket to the engine cylinder head and block. Tighten the bolts to 40 N·m (30 ft. lbs.) torque.

- (15) Attach the air conditioning compressor to the bracket. Tighten the bolts to 27 N·m (20 ft. lbs.) torque.

CAUTION: The serpentine drive belt must be routed correctly. Incorrect routing can cause the water pump to turn in the opposite direction causing the engine to overheat.

- (16) Install the serpentine drive belt and correctly tension the belt (refer to Group 7, Cooling System for the proper procedure).
- (17) Install the air cleaner and ducting.
- (18) Install the engine cylinder head cover.
- (19) Connect the hoses to the engine thermostat housing and fill the cooling system to the specified level (refer to Group 7, Cooling Systems for the proper procedure).
- (20) The automatic transmission throttle linkage and cable must be adjusted after completing the engine cylinder head installation (refer to Group 21, Transmissions for the proper procedures).
- (21) Install the temperature sending unit and connect the wire connector.
- (22) Connect the fuel line.
- (23) If equipped with air conditioning, install air compressor and charge A/C system (refer to Group 24 Heating and Air Conditioning).
- (24) Connect negative cable to battery.
- (25) Connect the upper radiator hose and heater hose at the engine thermostat housing.
- (26) Fill the cooling system. Check for leaks.

WARNING: USE EXTREME CAUTION WHEN THE ENGINE IS OPERATING. DO NOT STAND IN DIRECT LINE WITH THE FAN. DO NOT PUT HANDS NEAR THE PULLEYS, BELTS OR FAN. DO NOT WEAR LOOSE CLOTHING.

- (27) Operate the engine with the radiator cap off. Inspect for leaks and continue operating the engine until the engine thermostat opens. Add coolant, if required.

VALVES AND VALVE SPRINGS

This procedure is done with the engine cylinder head removed from the block.

REMOVAL

- (1) Remove the engine cylinder head from the cylinder block.
- (2) Use Valve Spring Compressor Tool MD-998772A and compress each valve spring.
- (3) Remove the valve locks, retainers, springs and valve stem oil seals. Discard the oil seals.

REMOVAL AND INSTALLATION (Continued)

(4) Use a smooth stone or a jewelers file to remove any burrs on the top of the valve stem, especially around the groove for the locks.

(5) Remove the valves, and place them in a rack in the same order as removed.

INSTALLATION

(1) Thoroughly clean the valve stems and the valve guide bores.

(2) Lightly lubricate the stem.

(3) Install the valve in the original valve guide bore.

(4) Install the replacement valve stem oil seals on the valve stems. If the 0.381 mm (0.015 inch) oversize valve stems are used, oversize oil seals are required.

(5) Position the valve spring and retainer on the engine cylinder head and compress the valve spring with Valve Spring Compressor Tool MD-998772A.

(6) Install the valve locks and release the tool.

(7) Tap the valve spring from side to side with a hammer to ensure that the spring is properly seated at the engine cylinder head. Also tap the top of the retainer to seat the valve locks.

(8) Install the engine cylinder head.

HYDRAULIC TAPPETS

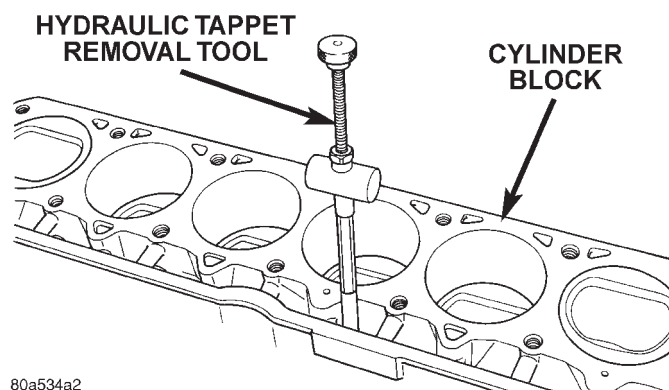
Retain all the components in the same order as removed.

REMOVAL

(1) Remove the engine cylinder head (Refer to cylinder head r&i in this section).

(2) Remove the push rods.

(3) Remove the tappets through the push rod openings in the cylinder block with a Hydraulic Valve Tappet Removal/Installation Tool (Fig. 38).



80a534a2

Fig. 38 Hydraulic Valve Tappet Removal—Installation Tool

INSTALLATION

It is not necessary to charge the tappets with engine oil. They will charge themselves within a very short period of engine operation.

(1) Dip each tappet in Mopar Engine Oil Supplement, or equivalent.

(2) Use Hydraulic Valve Tappet Removal/Installation Tool to install each tappet in the same bore from where it was originally removed.

(3) Install the cylinder head assy (Refer to cylinder head r&i in this section).

(4) Install the push rods in their original locations.

(5) Install the rocker arms and bridge and pivot assemblies at their original locations. Loosely install the capscrews at each bridge.

(6) Tighten the capscrews alternately, one turn at a time, to avoid damaging the bridges. Tighten the capscrews to 28 N·m (21 ft. lbs.) torque.

(7) Pour the remaining Mopar Engine Oil Supplement, or equivalent over the entire valve actuating assembly. The Mopar Engine Oil Supplement, or equivalent must remain with the engine oil for at least 1 609 km (1,000 miles). The oil supplement need not be drained until the next scheduled oil change.

(8) Install the engine cylinder head cover.

VIBRATION DAMPER

REMOVAL

(1) Disconnect negative cable from battery.

(2) Remove the serpentine drive belt and fan shroud.

(3) Remove the vibration damper retaining bolt and washer.

(4) Use Vibration Damper Removal Tool 7697 to remove the damper from the crankshaft (Fig. 39).

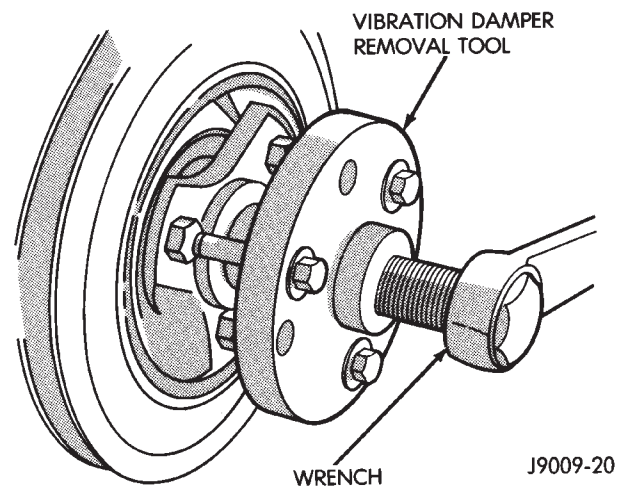


Fig. 39 Vibration Damper Removal Tool 7697

INSTALLATION

(1) Apply Mopar Silicone Rubber Adhesive Sealant to the keyway in the crankshaft and insert the key. With the key in position, align the keyway on the vibration damper hub with the crankshaft key and tap the damper onto the crankshaft.

REMOVAL AND INSTALLATION (Continued)

(2) Install the vibration damper retaining bolt and washer.

(3) Tighten the damper retaining bolt to 108 N·m (80 ft. lbs.) torque.

(4) Install the serpentine drive belt and tighten to the specified tension (refer to Group 7, Cooling Systems for the proper specifications and procedures).

(5) Connect negative cable to battery.

TIMING CASE COVER

REMOVAL

(1) Disconnect negative cable from battery.

(2) Remove the vibration damper.

(3) Remove the fan and hub assembly and remove the fan shroud.

(4) Remove the accessory drive brackets that are attached to the timing case cover.

(5) Remove the A/C compressor (if equipped) and generator bracket assembly from the engine cylinder head and move to one side.

(6) Remove the oil pan-to-timing case cover bolts and timing case cover-to-cylinder block bolts.

(7) Remove the timing case cover and gasket from the engine. Make sure the tension spring and thrust pin do not fall out of the preload bolt.

(8) Pry the crankshaft oil seal from the front of the timing case cover (Fig. 40).

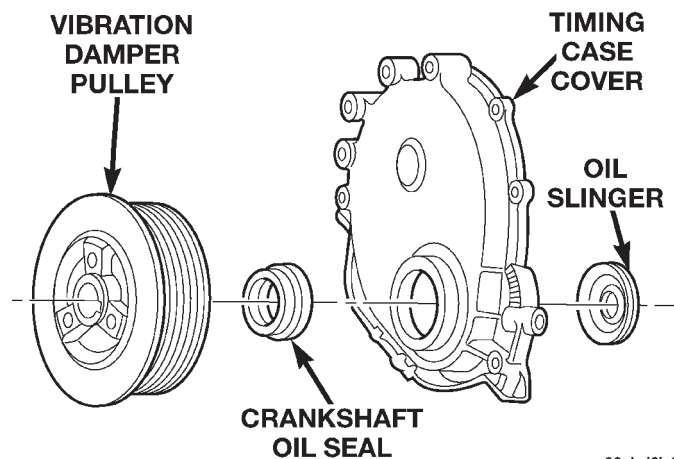


Fig. 40 Timing Case Cover Components

INSTALLATION

Clean the timing case cover, oil pan and cylinder block gasket surfaces.

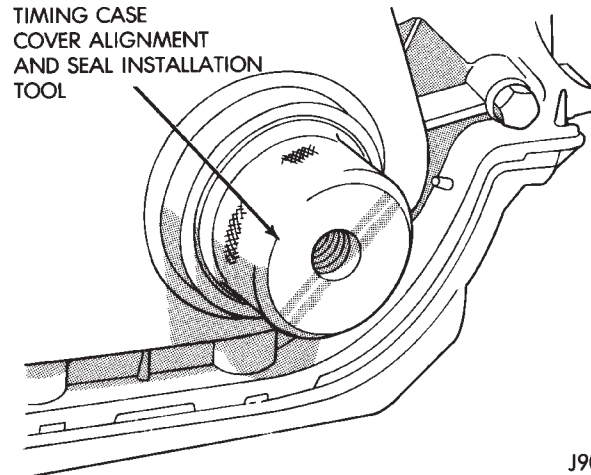
(1) Install a new crankshaft oil seal in the timing case cover. The open end of the seal should be toward the inside of the cover. Support the cover at the seal area while installing the seal. Force it into position with Seal Installation Tool 6139.

(2) Position the gasket on the cylinder block.

(3) Position the timing case cover on the oil pan gasket and the cylinder block. Make sure the tension

spring and thrust pin are in place in the camshaft preload bolt.

(4) Insert Timing Case Cover Alignment and Seal Installation Tool 6139 in the crankshaft opening in the cover (Fig. 41).



J9009-23

Fig. 41 Timing Case Cover Alignment and Seal Installation Tool 6139

(5) Install the timing case cover-to-cylinder block and the oil pan-to-timing case cover bolts.

(6) Tighten the 1/4 inch cover-to-block bolts to 7 N·m (60 in. lbs.) torque. Tighten the 5/16 inch front cover-to-block bolts to 22 N·m (192 in. lbs.) torque. Tighten the oil pan-to-cover 1/4 inch bolts to 9.5 N·m (84 in. lbs.) torque.

(7) Remove the cover alignment tool.

(8) Apply a light film of engine oil on the vibration damper hub contact surface of the seal.

(9) Apply Mopar Silicone Rubber Adhesive Sealant to the keyway in the crankshaft and insert the key. With the key inserted in the keyway in the crankshaft, install the vibration damper, washer and bolt. Lubricate and tighten the bolt to 108 N·m (80 ft. lbs.) torque.

(10) Install the A/C compressor (if equipped) and generator bracket assembly.

(11) Install the engine fan and hub assembly and shroud.

(12) Install the serpentine drive belt and tighten to obtain the specified tension.

(13) Connect negative cable to battery.

TIMING CHAIN AND SPROCKETS

REMOVAL

(1) Disconnect negative cable from battery.

(2) Remove the fan and shroud.

(3) Remove the serpentine drive belt.

(4) Remove the crankshaft vibration damper.

(5) Remove the timing case cover.

REMOVAL AND INSTALLATION (Continued)

(6) Rotate crankshaft until the "0" timing mark is closest to and on the center line with camshaft sprocket timing mark (Fig. 42).

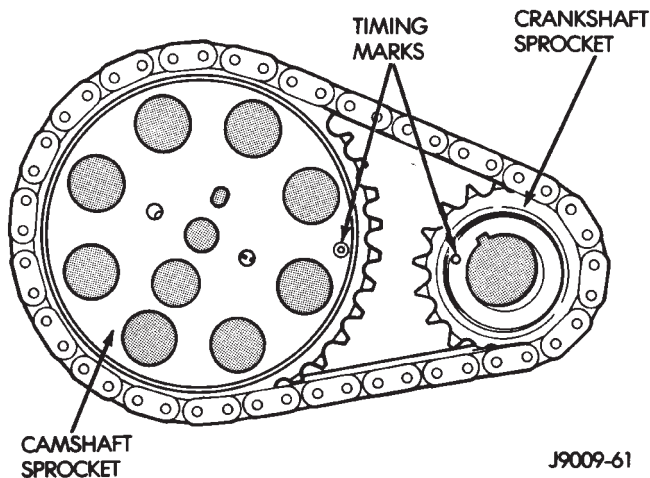


Fig. 42 Crankshaft—Camshaft Alignment—Typical

(7) Remove the oil slinger from the crankshaft.
 (8) Remove the tension spring and thrust pin from the preload bolt (Fig. 43). Remove the camshaft sprocket retaining preload bolt and washer.

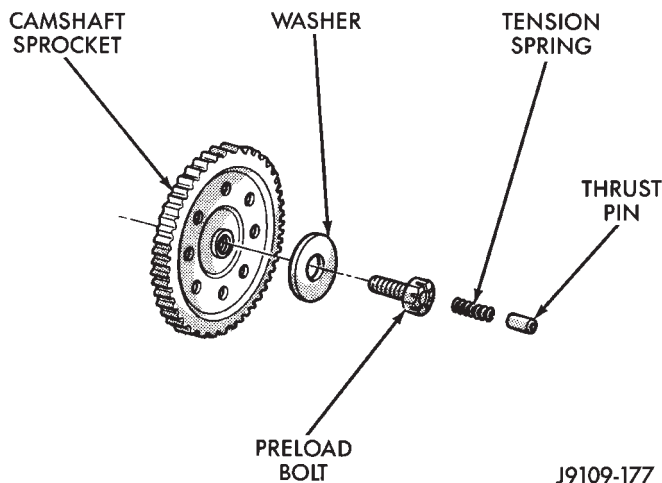


Fig. 43 Camshaft Sprocket Preload Bolt

(9) Remove the crankshaft sprocket, camshaft sprocket and timing chain as an assembly.

(10) Installation of the timing chain with the timing marks on the crankshaft and camshaft sprockets properly aligned ensures correct valve timing. A worn or stretched timing chain will adversely affect valve timing. If the timing chain deflects more than 12.7 mm (1/2 inch) replace it. The correct timing chain has 48 pins. A chain with more than 48 pins will cause excessive slack.

INSTALLATION

Assemble the timing chain, crankshaft sprocket and camshaft sprocket with the timing marks aligned (Fig. 44).

(1) Apply Mopar Silicone Rubber Adhesive Sealant to the keyway in the crankshaft and insert the key. With the key in the keyway on the crankshaft, install the assembly on the crankshaft and camshaft.

(2) Install the camshaft sprocket retaining preload bolt and washer (Fig. 43). Tighten the preload bolt to 108 N·m (80 ft. lbs.) torque.

(3) To verify correct installation of the timing chain, turn the crankshaft to position the camshaft sprocket timing mark as shown in (Fig. 44). Count the number of chain pins between the timing marks of both sprockets. There must be 15 pins.

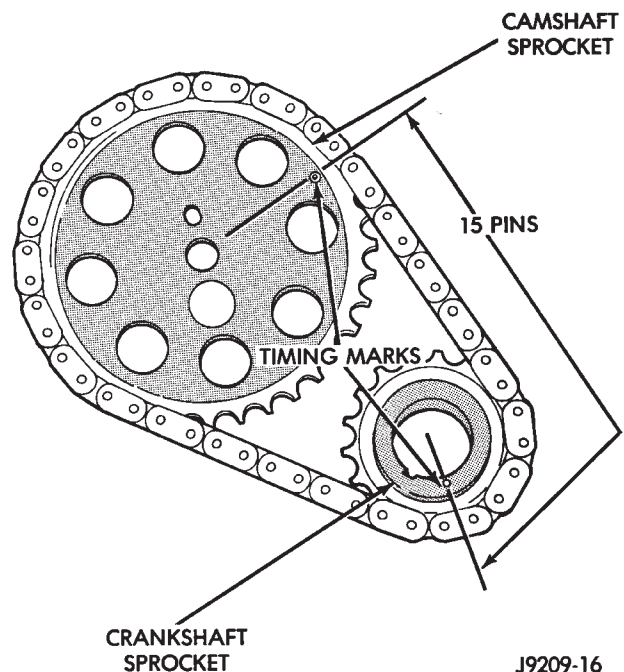


Fig. 44 Verify Sprocket—Chain Installation—Typical

(4) Install the crankshaft oil slinger.
 (5) Replace the oil seal in the timing case cover.
 (6) Lubricate the tension spring, thrust pin and pin bore in the preload bolt with Mopar Engine Oil Supplement, or equivalent. Install the spring and thrust pin in the preload bolt head (Fig. 43).

(7) Install the timing case cover and gasket.
 (8) With the key installed in the crankshaft keyway, install the vibration damper, washer and bolt. Lubricate and tighten the bolt to 108 N·m (80 ft. lbs.) torque.

(9) Install the serpentine drive belt and tighten to the specified tension (refer to Group 7, Cooling System for the proper procedure).

(10) Install the fan and hub assembly. Install the shroud.

(11) Connect negative cable to battery.

REMOVAL AND INSTALLATION (Continued)

CAMSHAFT

REMOVAL

WARNING: THE COOLANT IN A RECENTLY OPERATED ENGINE IS HOT AND PRESSURIZED. RELEASE THE PRESSURE BEFORE REMOVING THE DRAIN COCK, CAP AND DRAIN PLUGS.

- (1) Disconnect negative cable from battery.
- (2) Drain the cooling system. DO NOT waste reusable coolant. If the solution is clean, drain it into a clean container for reuse.
- (3) Remove the radiator or radiator and condenser, if equipped with A/C (refer to Group 7, Cooling System for the proper procedure).
- (4) Remove the distributor cap and mark the position of the rotor.
- (5) Remove the distributor and ignition wires.
- (6) Remove the engine cylinder head cover.
- (7) Remove the rocker arms, bridges and pivots.
- (8) Remove the push rods.
- (9) Remove the engine cylinder head and gasket.
- (10) Remove the hydraulic valve tappets from the engine cylinder block.
- (11) Remove the vibration damper.
- (12) Remove the timing case cover.
- (13) Remove the timing chain and sprockets.
- (14) Remove the front bumper and/or grille, as required.
- (15) Remove the camshaft (Fig. 45).

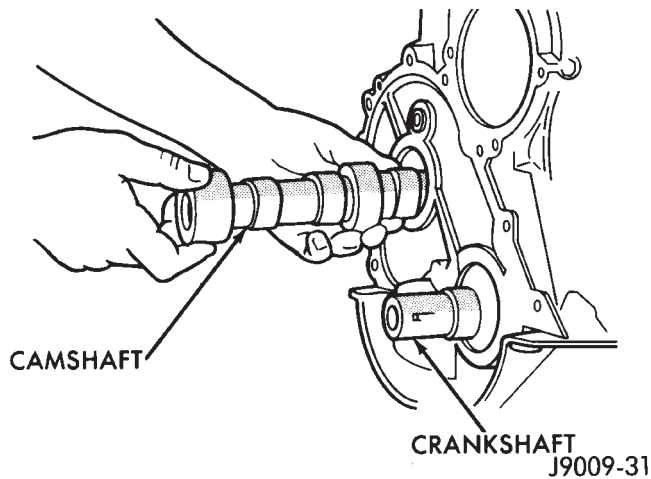


Fig. 45 Camshaft

INSTALLATION

- (1) Inspect the cam lobes for wear.
- (2) Inspect the bearing journals for uneven wear pattern or finish.
- (3) Inspect the bearings for wear.
- (4) Inspect the distributor drive gear for wear.
- (5) If the camshaft appears to have been rubbing against the timing case cover, examine the oil pres-

sure relief holes in the rear cam journal. The oil pressure relief holes must be free of debris.

(6) Lubricate the camshaft with Mopar Engine Oil Supplement, or equivalent.

(7) Carefully install the camshaft to prevent damage to the camshaft bearings (Fig. 45).

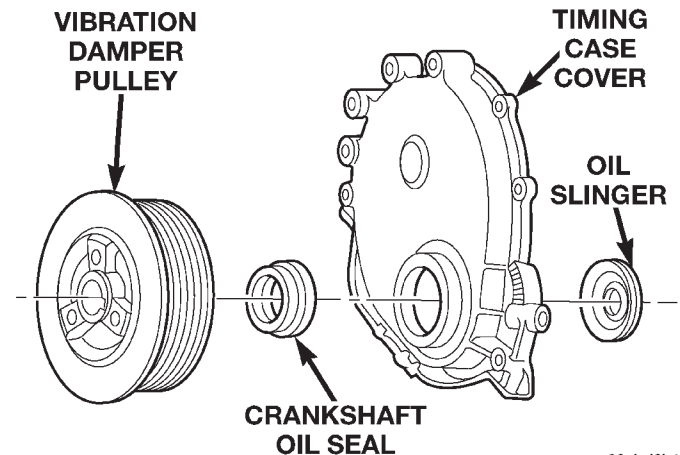
(8) Install the timing chain, crankshaft sprocket and camshaft sprocket with the timing marks aligned.

(9) Install the camshaft sprocket retaining preload bolt. Tighten the bolt to 108 N·m (80 ft. lbs.) torque.

(10) Lubricate the tension spring, the thrust pin and the pin bore in the preload bolt with Mopar Engine Oil Supplement, or equivalent. Install the spring and thrust pin in the preload bolt head.

(11) Install the timing case cover with a replacement oil seal (Fig. 46). Refer to Timing Case Cover Installation.

(12) Install the vibration damper (Fig. 46).



80abd2b1

Fig. 46 Timing Case Cover Components

- (13) Install the hydraulic valve tappets.
- (14) Install the cylinder head gasket with the numbers facing up.
- (15) Install the cylinder head and head bolts (Refer to cylinder head R&I in this section for torque values and tightening sequence).
- (16) Install the push rods.
- (17) Install the rocker arms and pivot and bridge assemblies. Tighten each of the capscrews for each bridge alternately, one turn at a time, to avoid damaging the bridge (Refer to Rocker Arms and Push Rods in this section).
- (18) Install the engine cylinder head cover.
- (19) Position the oil pump gear. Refer to Distributor in the Component Removal/Installation section of Group 8D, Ignition Systems.
- (20) Install the distributor and ignition wires. Refer to Distributor in the Component Removal/Installation section of Group 8D, Ignition Systems.

REMOVAL AND INSTALLATION (Continued)

(21) Install the serpentine drive belt and tighten to the specified tension (refer to Group 7, Cooling System for the proper procedure).

NOTE: During installation, lubricate the hydraulic valve tappets and all valve components with Mopar Engine Oil Supplement, or equivalent. The Mopar Engine Oil Supplement, or equivalent must remain with the engine oil for at least 1609 km (1,000 miles). The oil supplement need not be drained until the next scheduled oil change.

(22) Install the A/C condenser and receiver/drier assembly, if equipped (refer to Group 24, Heating and Air Conditioning).

CAUTION: Both service valves must be opened before the air conditioning system is operated.

(23) Install the radiator, connect the hoses and fill the cooling system to the specified level (refer to Group 7, Cooling System for the proper procedure).

(24) Check the ignition timing and adjust as necessary.

(25) Install the grille and bumper, if removed.

(26) Connect negative cable to battery.

CAMSHAFT PIN REPLACEMENT

REMOVAL

WARNING: DO NOT LOOSEN THE RADIATOR DRAIN COCK WITH THE SYSTEM HOT AND PRESSURIZED BECAUSE SERIOUS BURNS FROM COOLANT CAN OCCUR.

- (1) Disconnect negative cable from battery.
- (2) Drain the radiator. DO NOT waste reusable coolant. Drain the coolant into a clean container.
- (3) Remove the fan and shroud.
- (4) Disconnect the radiator overflow tube, radiator hoses, automatic transmission fluid cooler pipes (if equipped).
- (5) Remove the radiator.
- (6) If equipped with air conditioning:

CAUTION: DO NOT loosen or disconnect any air conditioner system fittings. Move the condenser and receiver/drier aside as a complete assembly.

- (a) Remove the A/C compressor serpentine drive belt idler pulley.
- (b) Disconnect and remove the generator.
- (c) Remove the A/C condenser attaching bolts and move the condenser and receiver/drier assembly up and out of the way.
- (7) Remove the serpentine drive belt.
- (8) Remove the crankshaft vibration damper.

(9) Remove the timing case cover. Clean the gasket material from the cover.

(10) Remove the thrust pin and tension spring from the preload bolt head.

(11) Rotate crankshaft until the crankshaft sprocket timing mark is closest to and on the center line with the camshaft sprocket timing mark (Fig. 47).

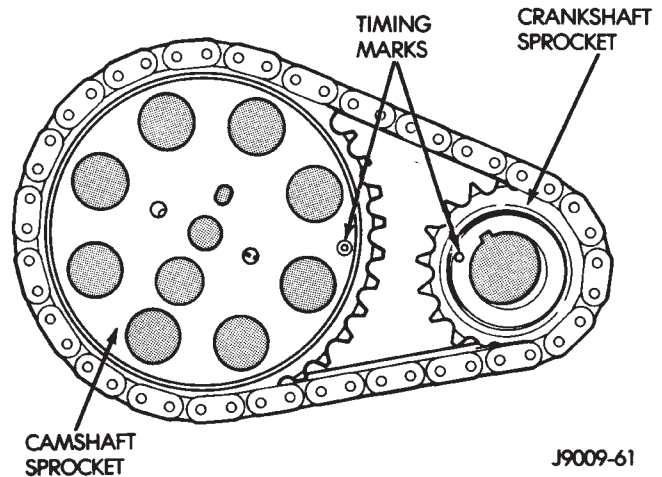


Fig. 47 Timing Chain Alignment—Typical

(12) Remove the camshaft sprocket preload retaining bolt and washer.

(13) Remove the crankshaft oil slinger.

(14) Remove the sprockets and chain as an assembly.

CAUTION: The following procedural step must be accomplished to prevent the camshaft from damaging the rear camshaft plug during pin installation.

(15) Inspect the damaged camshaft pin.

(16) If the pin is a spring-type pin, remove the broken pin by inserting a self-tapping screw into the pin and carefully pulling the pin from the camshaft.

(17) If the pin is a dowel-type pin, center-punch it. Ensure the exact center is located when center-punching the pin.

CAUTION: Cover the opened oil pan area to prevent metal chips from entering the pan.

(18) Drill into the pin center with a 4 mm (5/32 inch) drill bit.

(19) Insert a self-tapping screw into the drilled pin and carefully pull the pin from the camshaft.

CAMSHAFT BEARINGS

The camshaft rotates within four steel-shelled, babbitt-lined bearings that are pressed into the cylinder block and then line reamed. The camshaft bearing bores and bearing diameters are not the same size. They are stepped down in 0.254 mm

REMOVAL AND INSTALLATION (Continued)

(0.010 inch) increments from the front bearing (largest) to the rear bearing (smallest). This permits easier removal and installation of the camshaft. The camshaft bearings are pressure lubricated.

NOTE: It is not advisable to attempt to replace camshaft bearings unless special removal and installation tools are available.

Camshaft end play is maintained by the load placed on the camshaft by the sprocket preload bolt tension spring and thrust pin.

INSTALLATION

- (1) Clean the camshaft pin hole.
- (2) Compress the center of the replacement spring pin with vise grips.
- (3) Carefully drive the pin into the camshaft pin hole until it is seated.
- (4) Install the camshaft sprocket, crankshaft sprocket and timing chain with the timing marks aligned (Fig. 47).
- (5) To verify correct installation of the timing chain, turn the crankshaft to position the camshaft sprocket timing mark as shown in (Fig. 48). Count the number of chain pins between the timing marks of both sprockets. There must be 15 pins.

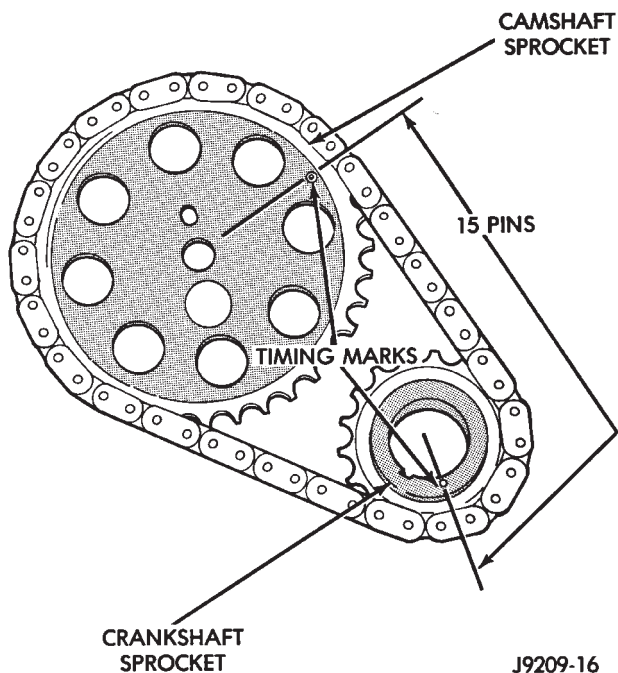


Fig. 48 Verify Crankshaft—Camshaft Installation—Typical

- (6) Install the crankshaft oil slinger.
- (7) Tighten the camshaft sprocket preload bolt to 108 N·m (80 ft. lbs.) torque.
- (8) Check the valve timing.

(9) Lubricate the tension spring, the thrust pin and the pin bore in the preload bolt with Mopar Engine Oil Supplement, or equivalent. Install the spring and thrust pin in the preload bolt head.

(10) Coat both sides of the replacement timing case cover gasket with gasket sealer. Apply a 3 mm (1/8 inch) bead of Mopar Silicone Rubber Adhesive Sealant, or equivalent to the joint formed at the oil pan and cylinder block.

(11) Position the timing case cover on the oil pan gasket and the cylinder block.

(12) Place Timing Case Cover Alignment and Seal Installation Tool 6139 in the crankshaft opening in the cover (Fig. 49).

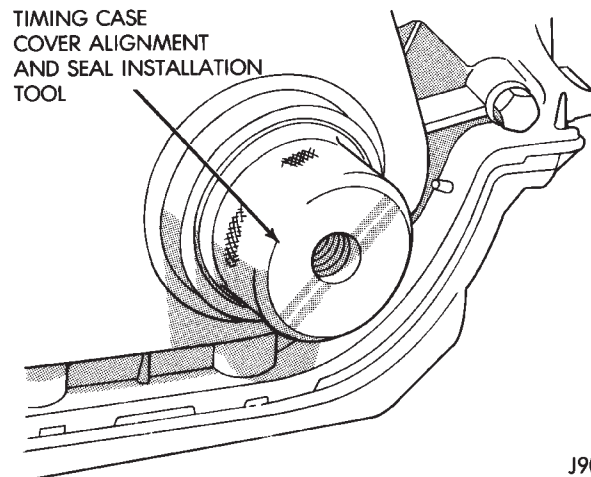


Fig. 49 Timing Case Cover Alignment and Seal Installation Tool 6139

(13) Install the timing case cover-to-cylinder block bolts. Install the oil pan-to-timing case cover bolts.

(14) Tighten the 1/4 inch cover-to-block bolts to 7 N·m (60 in. lbs.) torque. Tighten the 5/16 inch front cover-to-block bolts to 22 N·m (192 in. lbs.) torque. Tighten the oil pan-to-cover 1/4 inch bolts to 14 N·m (120 in. lbs.) torque. Tighten the oil pan-to-cover 5/16 inch bolts to 18 N·m (156 in. lbs.) torque.

(15) Remove the cover alignment tool and install a replacement oil seal into the cover.

(16) Install the vibration damper on the crankshaft.

(17) Lubricate and tighten the damper bolt to 108 N·m (80 ft. lbs.) torque.

(18) If equipped with air conditioning:

- (a) Install the A/C compressor serpentine drive belt idler pulley.
- (b) Install the generator.
- (c) Install the A/C condenser and receiver/drier assembly.

(19) Install the serpentine drive belt on the pulleys and tighten (refer to Group 7, Cooling System for the specifications and procedures).

REMOVAL AND INSTALLATION (Continued)

(20) Install the radiator. Connect the radiator hoses and automatic transmission fluid cooler pipes, if equipped. Fill the cooling system.

(21) Install the fan and shroud.

(22) Connect negative cable to battery.

CRANKSHAFT MAIN BEARINGS

REMOVAL

- (1) Disconnect negative cable from battery.
- (2) Remove the spark plugs.
- (3) Raise the vehicle.
- (4) Remove the oil pan and oil pump.
- (5) Remove main bearing cap brace (Fig. 50).

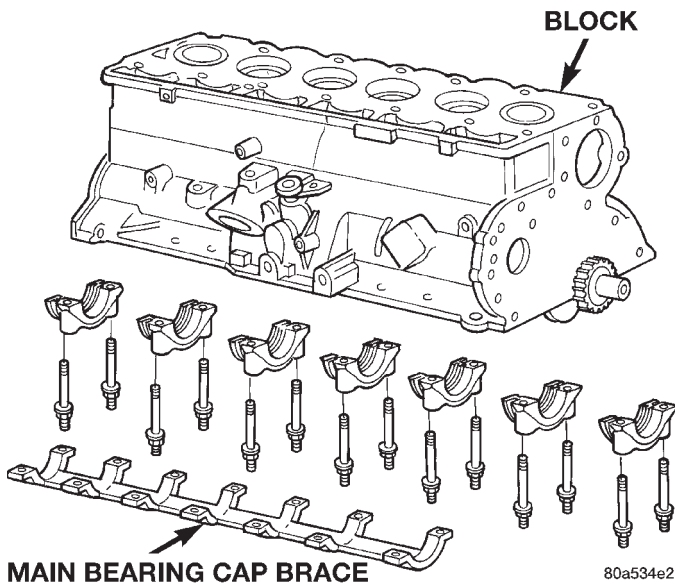


Fig. 50 Main Bearing Caps and Brace.

(6) Remove only one main bearing cap and lower insert at a time (Fig. 51).

(7) Remove the lower insert from the bearing cap.

(8) Remove the upper insert by LOOSENING (DO NOT REMOVE) all of the other bearing caps. Now insert a small cotter pin tool in the crankshaft journal oil hole. Bend the cotter pin as illustrated to fabricate the tool (Fig. 52). With the cotter pin tool in place, rotate the crankshaft so that the upper bearing insert will rotate in the direction of its locking tab. Because there is no hole in the No.3 main journal, use a tongue depressor or similar soft-faced tool to remove the bearing insert (Fig. 52). After moving the insert approximately 25 mm (1 inch), it can be removed by applying pressure under the tab.

(9) Using the same procedure described above, remove the remaining bearing inserts one at a time for inspection.

INSTALLATION

(1) Lubricate the bearing surface of each insert with engine oil.

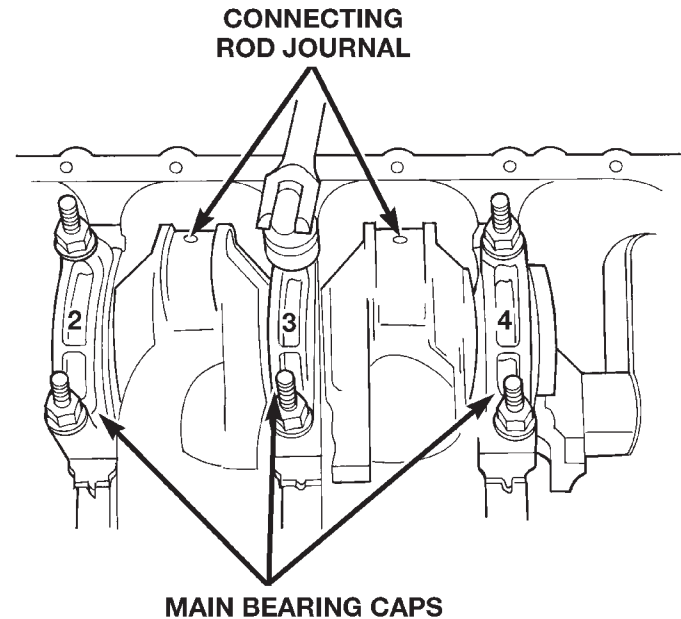


Fig. 51 Removing Main Bearing Caps and Lower Inserts

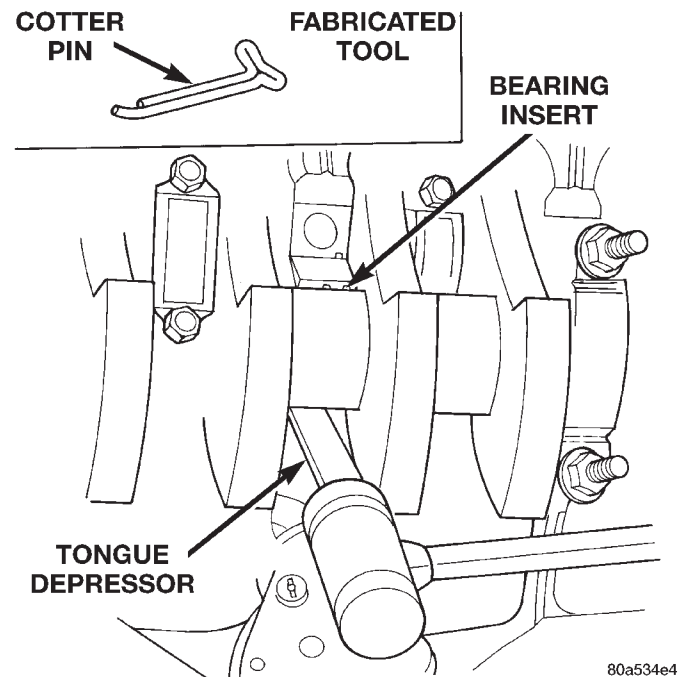


Fig. 52 Removing Upper Inserts

(2) Loosen all the main bearing caps. Install the main bearing upper inserts.

(3) Install the lower bearing inserts into the main bearing caps.

(4) Install the main bearing cap(s) and lower insert(s).

(5) Tighten the bolts of caps 1, 2, 4, 5, 6, and 7 to 54 N·m (40 ft. lbs.) torque. Now tighten these bolts to

REMOVAL AND INSTALLATION (Continued)

95 N·m (70 ft. lbs.) torque. Finally, tighten these bolts to 108 N·m (80 ft. lbs.) torque.

(6) Push the crankshaft forward and backward. Load the crankshaft front or rear and tighten cap bolt No.3 to 54 N·m (40 ft. lbs.) torque. Then tighten to 95 N·m (70 ft. lbs.) torque and finally tighten to 108 N·m (80 ft. lbs.) torque.

(7) Rotate the crankshaft after tightening each main bearing cap to ensure the crankshaft rotates freely.

(8) Check crankshaft end play. Crankshaft end play is controlled by the thrust bearing which is flange and installed at the No.2 main bearing position.

(a) Attach a magnetic base dial indicator to the cylinder block at either the front or rear of the engine.

(b) Position the dial indicator rod so that it is parallel to the center line of the crankshaft.

(c) Pry the crankshaft forward, position the dial indicator to zero.

(d) Pry the crankshaft forward and backward. Note the dial indicator readings. End play is the difference between the high and low measurements (Fig. 53). Correct end play is 0.038-0.165 mm (0.0015-0.0065 inch). The desired specifications are 0.051-0.064 mm (0.002-0.0025 inch).

(e) If end play is not within specification, inspect crankshaft thrust faces for wear. If no wear is apparent, replace the thrust bearing and measure end play. If end play is still not within specification, replace the crankshaft.

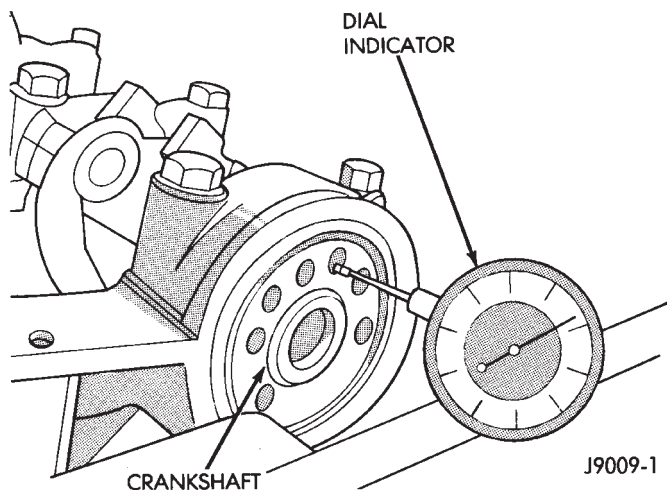


Fig. 53 Crankshaft End Play Measurement

(9) If the crankshaft was removed, install the crankshaft into the cylinder block (refer to Cylinder Block - Assemble).

(10) Install main bearing cap brace tighten nuts to 47 N·m (35 ft. lbs.) torque.

(11) Install oil pump assy. and tighten attaching bolts to 23 N·m (17 ft. lbs.)

(12) Install the oil pan.

(13) Install the drain plug. Tighten the plug to 34 N·m (25 ft. lbs.) torque.

(14) Lower the vehicle.

(15) Install the spark plugs. Tighten the plugs to 37 N·m (27 ft. lbs.) torque.

(16) Fill the oil pan with engine oil to the full mark on the dipstick level.

(17) Connect negative cable to battery.

OIL PAN

REMOVAL

(1) Disconnect negative cable from battery.

(2) Raise the vehicle.

(3) Remove the oil pan drain plug and drain the engine oil.

(4) Disconnect the exhaust pipe at the exhaust manifold.

(5) Disconnect the exhaust hanger at the catalytic converter and lower the pipe.

(6) Remove the starter motor.

(7) Remove the engine flywheel and transmission torque converter housing access cover.

(8) If equipped with an oil level sensor, disconnect the sensor.

(9) Position a jack stand directly under the engine vibration damper.

(10) Place a piece of wood (2 x 2) between the jack stand and the engine vibration damper.

(11) Remove the engine mount through bolts.

(12) Using the jack stand, raise the engine until adequate clearance is obtained to remove the oil pan.

(13) Remove the oil pan bolts. Carefully slide the oil pan and gasket to the rear. If equipped with an oil level sensor, take care not to damage the sensor.

INSTALLATION

(1) Clean the block and pan gasket surfaces.

(2) Fabricate 4 alignment dowels from 1 1/2 x 1/4 inch bolts. Cut the head off the bolts and cut a slot into the top of the dowel. This will allow easier installation and removal with a screwdriver (Fig. 54).

(3) Install two dowels in the timing case cover. Install the other two dowels in the cylinder block (Fig. 55).

(4) Slide the one-piece gasket over the dowels and onto the block and timing case cover.

(5) Position the oil pan over the dowels and onto the gasket. If equipped with an oil level sensor, take care not to damage the sensor.

(6) Install the 1/4 inch oil pan bolts. Tighten these bolts to 9.5 N·m (84 in. lbs.) torque. Install the 5/16 inch oil pan bolts (Fig. 56). Tighten these bolts to 15 N·m (132 in. lbs.) torque.

REMOVAL AND INSTALLATION (Continued)

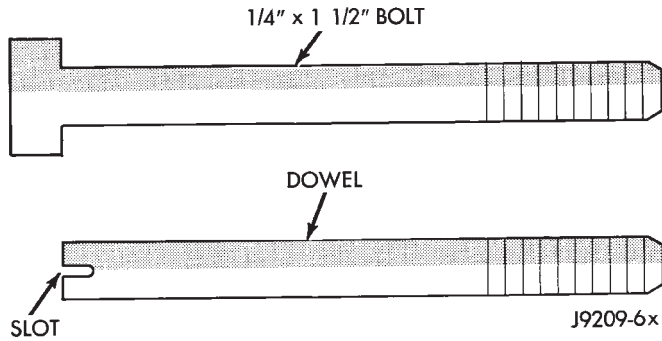


Fig. 54 Fabrication of Alignment Dowels

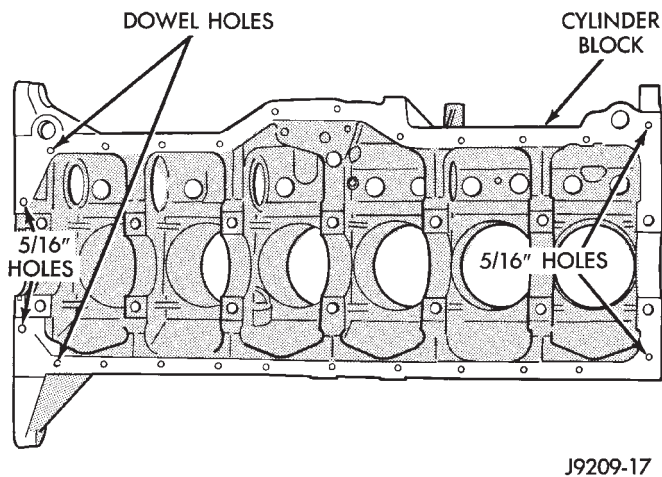


Fig. 55 Position of Dowels in Cylinder Block

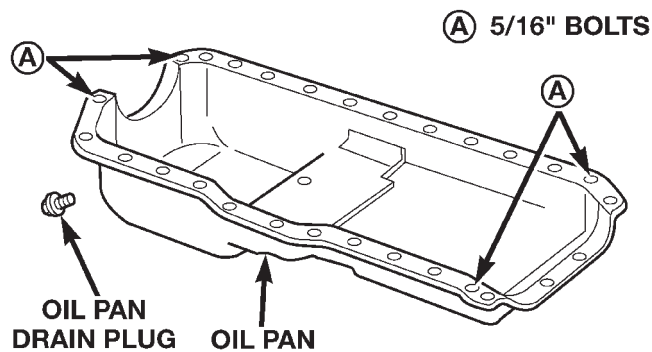


Fig. 56 Position of 5/16 inch Oil Pan Bolts

(7) Remove the dowels. Install the remaining 1/4 inch oil pan bolts. Tighten these bolts to 9.5 N·m (84 in. lbs.) torque.

(8) Lower the engine until it is properly located on the engine mounts.

(9) Install the through bolts and tighten the nuts.

(10) Lower the jack stand and remove the piece of wood.

(11) Install the engine flywheel and transmission torque converter housing access cover.

(12) Install the engine starter motor.

(13) Connect the exhaust pipe to the hanger and to the engine exhaust manifold.

(14) Install the oil pan drain plug (Fig. 56). Tighten the plug to 34 N·m (25 ft. lbs.) torque.

(15) Lower the vehicle.

(16) Connect negative cable to battery.

(17) Fill the oil pan with engine oil to the specified level.

WARNING: USE EXTREME CAUTION WHEN THE ENGINE IS OPERATING. DO NOT STAND IN A DIRECT LINE WITH THE FAN. DO NOT PUT YOUR HANDS NEAR THE PULLEYS, BELTS OR FAN. DO NOT WEAR LOOSE CLOTHING.

(18) Start the engine and inspect for leaks.

PISTONS AND CONNECTING RODS

REMOVAL

(1) Remove the engine cylinder head cover.

(2) Remove the rocker arms, bridges and pivots.

(3) Remove the push rods.

(4) Remove the engine cylinder head.

(5) Position the pistons one at a time near the bottom of the stroke. Use a ridge reamer to remove the ridge from the top end of the cylinder walls. Use a protective cloth to collect the cuttings.

(6) Raise the vehicle.

(7) Drain the engine oil.

(8) Remove the oil pan and gasket.

(9) Remove the connecting rod bearing caps and inserts. Mark the caps and rods with the cylinder bore location. The connecting rods and caps are stamped with a two letter combination (Fig. 57).

(10) Lower the vehicle until it is about 2 feet from the floor.

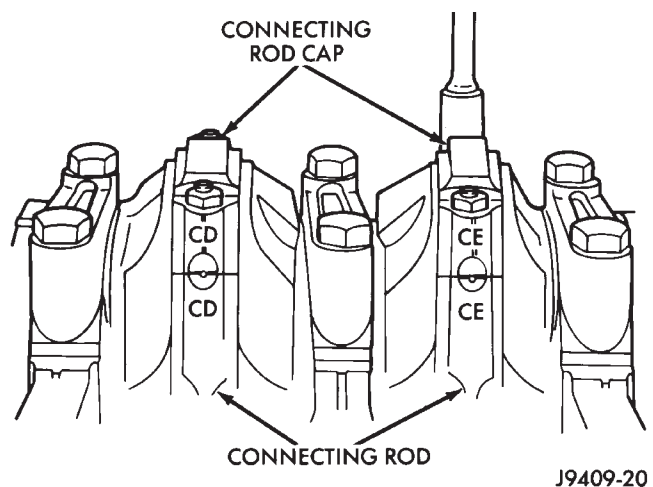


Fig. 57 Stamped Connecting Rods and Caps

REMOVAL AND INSTALLATION (Continued)

CAUTION: Ensure that the connecting rod bolts **DO NOT** scratch the crankshaft journals or cylinder walls. Short pieces of rubber hose, slipped over the rod bolts will provide protection during removal.

(11) Have an assistant push the piston and connecting rod assemblies up and through the top of the cylinder bores (Fig. 58).

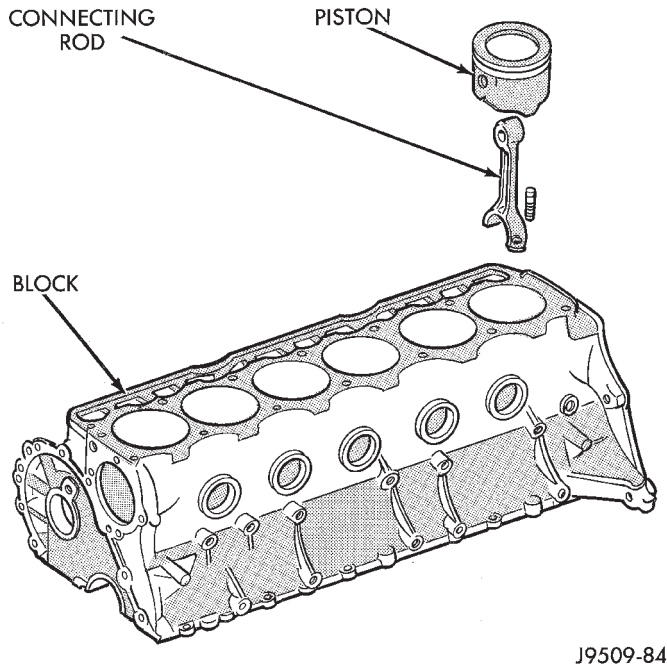


Fig. 58 Removal of Connecting Rod and Piston Assembly

INSTALLATION

(1) Clean the cylinder bores thoroughly. Apply a light film of clean engine oil to the bores with a clean lint-free cloth.

(2) Install the piston rings on the pistons if removed.

(3) Lubricate the piston and rings with clean engine oil.

CAUTION: Ensure that connecting rod bolts **DO NOT** scratch the crankshaft journals or cylinder walls. Short pieces of rubber hose slipped over the connecting rod bolts will provide protection during installation.

(4) Use a piston ring compressor to install the connecting rod and piston assemblies through the top of the cylinder bores (Fig. 59).

(5) Ensure the arrow on the piston top points to the front of the engine (Fig. 59).

(6) Raise the vehicle.

(7) Each bearing insert is fitted to its respective journal to obtain the specified clearance between the bearing and the journal. In production, the select fit

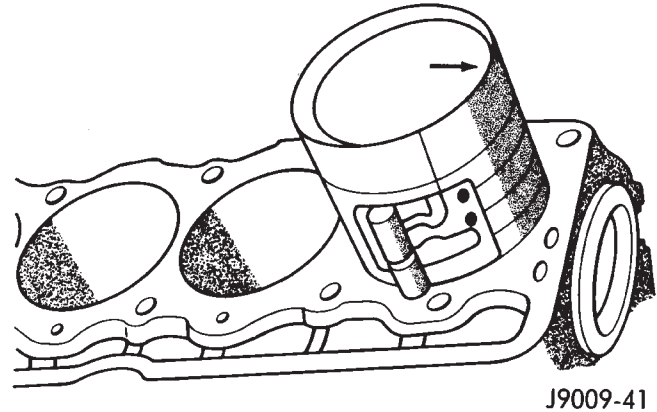


Fig. 59 Rod and Piston Assembly Installation

is obtained by using various-sized, color-coded bearing inserts as listed in the Connecting Rod Bearing Fitting Chart. The color code appears on the edge of the bearing insert. The size is not stamped on inserts used for production of engines.

(8) The rod journal is identified during the engine production by a color-coded paint mark on the adjacent cheek or counterweight toward the flange (rear) end of the crankshaft. The color codes used to indicate journal sizes are listed in the Connecting Rod Bearing Fitting Chart.

(9) When required, upper and lower bearing inserts of different sizes may be used as a pair (refer to Connecting Rod Bearing Fitting Chart). A standard size insert is sometimes used in combination with a 0.025 mm (0.001 inch) undersize insert to reduce clearance 0.013 mm (0.0005 inch).

CAUTION: **DO NOT** intermix bearing caps. Each connecting rod and bearing cap are stamped with the cylinder number. The stamp is located on a machined surface adjacent to the oil squirt hole that faces the camshaft side of the cylinder block.

(10) Install the connecting rod bearing caps and inserts in the same positions as removed.

CAUTION: Verify that the oil squirt holes in the rods face the camshaft and that the arrows on the pistons face the front of the engine.

(11) Install the oil pan and gaskets as outlined in the installation procedure.

(12) Lower the vehicle.

(13) Install the engine cylinder head, push rods, rocker arms, bridges, pivots and engine cylinder head cover.

(14) Fill the crankcase with engine oil.

REAR MAIN OIL SEALS

The crankshaft rear main bearing oil seal consists of two half pieces of viton with a single lip that effec-

REMOVAL AND INSTALLATION (Continued)

tively seals the rear of the crankshaft. Replace the upper and lower seal halves as a unit to ensure leak-free operation.

REMOVAL

- (1) Remove the transmission inspection cover.
- (2) Remove the oil pan.
- (3) Remove the main bearing cap brace.
- (4) Remove the rear main bearing cap (No.7).
- (5) Push the upper seal out of the groove. Ensure that the crankshaft and seal groove are not damaged.
- (6) Remove the lower half of the seal from the bearing cap.

INSTALLATION

- (1) Wipe the seal surface area of the crankshaft until it is clean.
- (2) Apply a thin coat of engine oil.
- (3) Coat the lip of the seal with engine oil.
- (4) Carefully position the upper seal into the groove in the cylinder block. The lip of the seal faces toward the front of the engine.
- (5) Place the lower half of the seal into bearing cap No.7 (Fig. 60).
- (6) Coat the outer curved surface of the lower seal with soap and the lip of the seal with engine oil (Fig. 60).

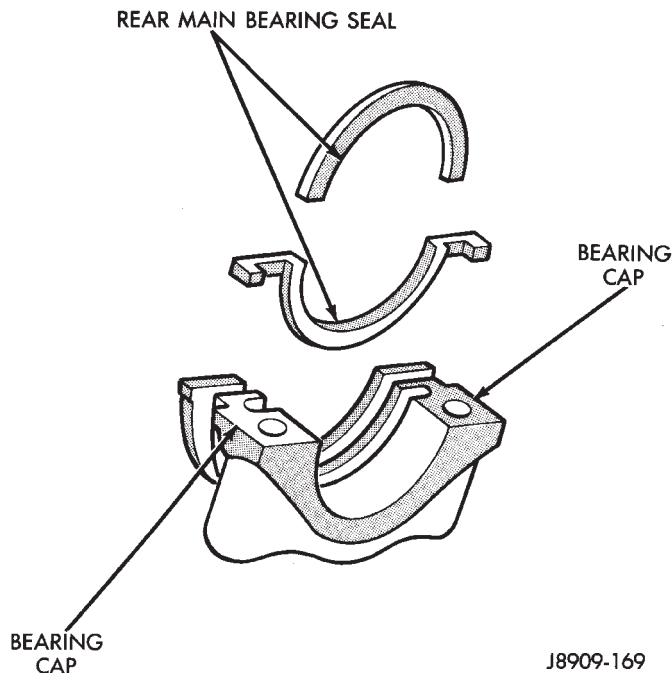
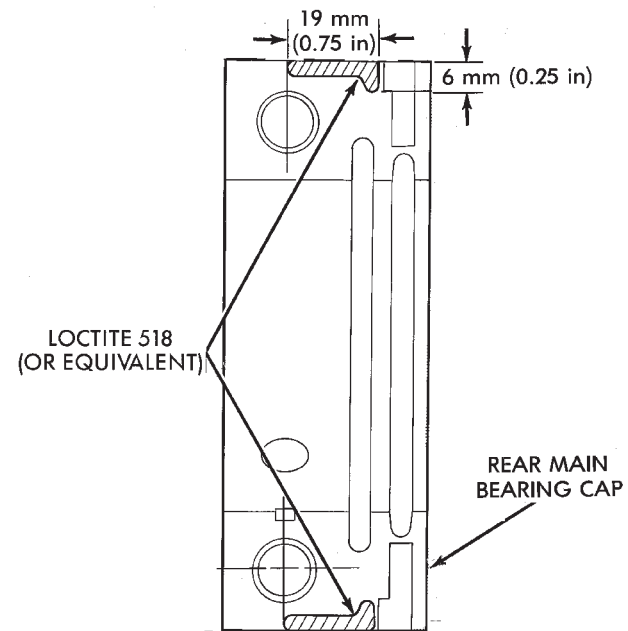


Fig. 60 Rear Main Bearing Oil Seal

- (7) Position the lower seal into the bearing cap recess and seat it firmly. Be sure the seal is flush with the cylinder block pan rail.
- (8) Apply Loctite 518, or equivalent on the rear bearing cap (Fig. 61). The bead should be 3 mm

(0.125 in) thick. DO NOT apply Loctite 518, or equivalent to the lip of the seal.



J9509-89

Fig. 61 Location of Loctite 518 (or equivalent)

- (9) Install the rear main bearing cap. DO NOT strike the cap more than twice for proper engagement.
- (10) Tighten all main bearing bolts to 108 N·m (80 ft. lbs.) torque.
- (11) Install the main bearing cap brace. Tighten nuts to 47 N·m (35 ft. lbs.).
- (12) Install the oil pan gasket and oil pan. Tighten 1/4 - 20 screws to 14 N·m (120 in. lbs.). Tighten 5/16 - 18 screws to 18 N·m (156 in. lbs.).
- (13) Install the engine flywheel or converter drive plate. Tighten bolts to 142 N·m (105 ft. lbs.).

OIL PUMP

A gear-type oil pump is mounted at the underside of the cylinder block opposite the No.4 main bearing.

The pump incorporates a nonadjustable pressure relief valve to limit maximum pressure to 517 kPa (75 psi). In the relief position, the valve permits oil to bypass through a passage in the pump body to the inlet side of the pump.

Oil pump removal or replacement will not affect the distributor timing because the distributor drive gear remains in mesh with the camshaft gear.

REMOVAL

- (1) Drain the engine oil.
- (2) Remove the oil pan.
- (3) Remove the pump-to-cylinder block attaching bolts. Remove the pump assembly with gasket (Fig. 62).

REMOVAL AND INSTALLATION (Continued)

CAUTION: If the oil pump is not to be serviced, **DO NOT** disturb position of oil inlet tube and strainer assembly in pump body. If the tube is moved within the pump body, a replacement tube and strainer assembly must be installed to assure an airtight seal.

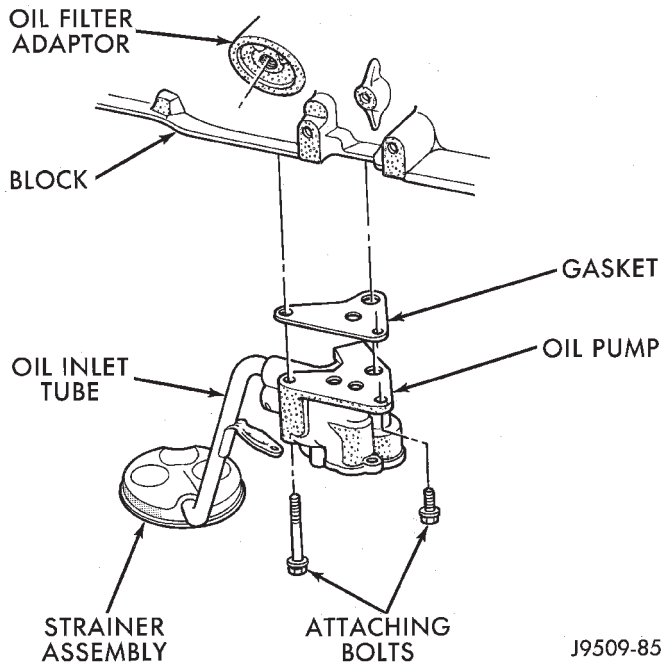


Fig. 62 Oil Pump Assembly

INSTALLATION

- (1) Install the oil pump on the cylinder block using a replacement gasket. Tighten the bolts to 23 N·m (17 ft. lbs.) torque.
- (2) Install the oil pan.
- (3) Fill the oil pan with oil to the specified level.

TIMING CASE COVER OIL SEAL

This procedure is done with the timing case cover installed.

REMOVAL

- (1) Disconnect negative cable from battery.
- (2) Remove the serpentine drive belt.
- (3) Remove the vibration damper.
- (4) Remove the radiator shroud.
- (5) Carefully remove the oil seal. Make sure seal bore is clean.

INSTALLATION

- (1) Position the replacement oil seal on Timing Case Cover Alignment and Seal Installation Tool 6139 with seal open end facing inward. Apply a light film of Perfect Seal, or equivalent, on the outside diameter of the seal. Lightly coat the crankshaft with engine oil.

- (2) Position the tool and seal over the end of the crankshaft and insert a draw screw tool into Seal Installation Tool 6139 (Fig. 63). Tighten the nut against the tool until it contacts the cover.

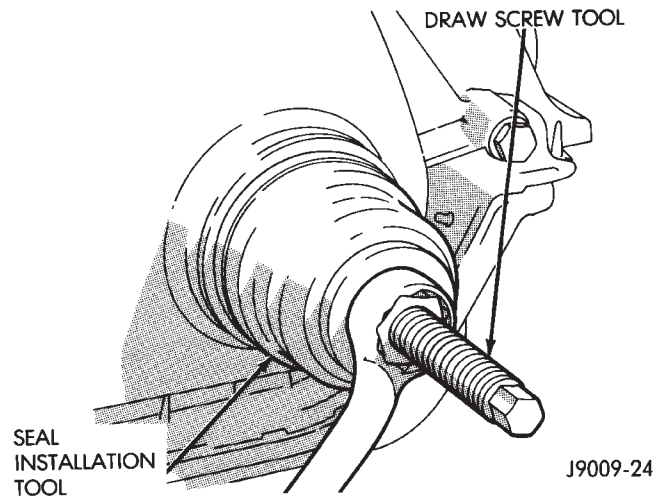


Fig. 63 Timing Case Cover Oil Seal Installation

- (3) Remove the tools. Apply a light film of engine oil on the vibration damper hub contact surface of the seal.

- (4) Apply Mopar Silicone Rubber Adhesive Sealant to the keyway in the crankshaft and insert the key. With the key inserted in the keyway in the crankshaft, install the vibration damper, washer and bolt. Lubricate and tighten the bolt to 108 N·m (80 ft. lbs.) torque.

- (5) Install the serpentine belt and tighten to the specified tension (refer to Group 7, Cooling Systems for the proper specifications and procedures).

- (6) Install the radiator shroud.

- (7) Connect negative cable to battery.

DISASSEMBLY AND ASSEMBLY

VALVE SERVICE

Clean all carbon deposits from the combustion chambers, valve ports, valve stems, valve stem guides and head.

Clean all grime and gasket material from the engine cylinder head machined gasket surface.

Inspect for cracks in the combustion chambers and valve ports.

Inspect for cracks on the exhaust seat.

Inspect for cracks in the gasket surface at each coolant passage.

Inspect valves for burned, cracked or warped heads.

Inspect for scuffed or bent valve stems.

Replace valves displaying any damage.

DISASSEMBLY AND ASSEMBLY (Continued)**VALVE REFACING**

(1) Use a valve refacing machine to reface the intake and exhaust valves to the specified angle.

(2) After refacing, a margin of at least 0.787 mm (0.031 inch) must remain (Fig. 64). If the margin is less than 0.787 mm (0.031 inch), the valve must be replaced.

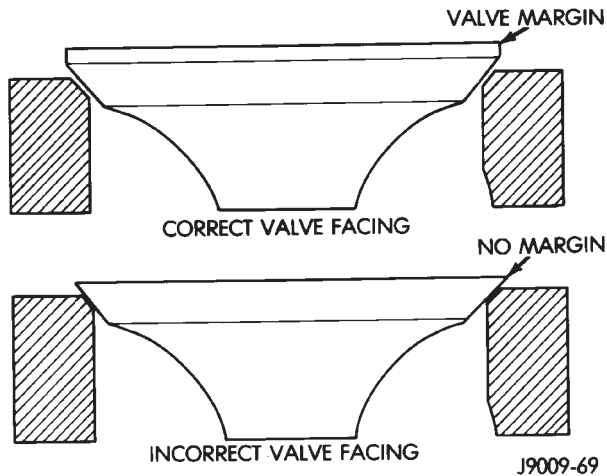


Fig. 64 Valve Facing Margin

VALVE SEAT REFACING

(1) Install a pilot of the correct size in the valve guide bore. Reface the valve seat to the specified angle with a good dressing stone. Remove only enough metal to provide a smooth finish.

(2) Use tapered stones to obtain the specified seat width when required.

(3) Control valve seat runout to a maximum of 0.0635 mm (0.0025 in.) (Fig. 65).

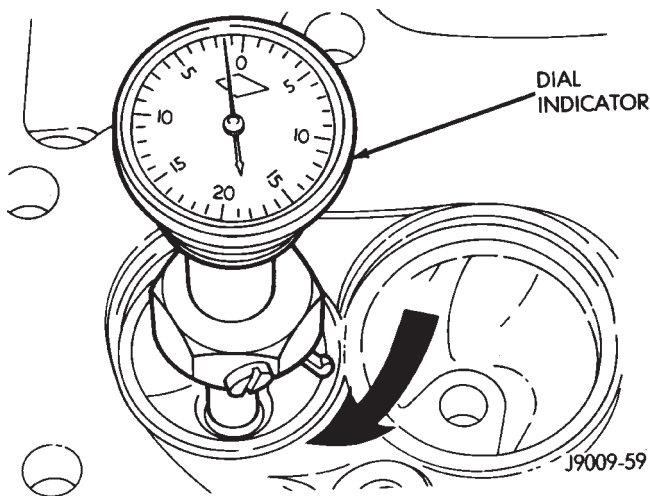


Fig. 65 Measurement of Valve Seat Runout

VALVE STEM OIL SEAL REPLACEMENT

Valve stem oil seals are installed on each valve stem to prevent rocker arm lubricating oil from entering the combustion chamber through the valve

guide bores. One seal is marked INT (intake valve) and the other is marked EXH (exhaust valve).

Replace the oil seals whenever valve service is performed or if the seals have deteriorated.

VALVE GUIDES

The valve guides are an integral part of the engine cylinder head and are not replaceable.

When the valve stem guide clearance is excessive, the valve guide bores must be reamed oversize. Service valves with oversize stems are available in 0.076 mm (0.003 inch) and 0.381 mm (0.015 inch) increments.

Corresponding oversize valve stem seals are also available and must be used with valves having 0.381 mm (0.015 inch) oversize stems.

NOTE: If the valve guides are reamed oversize, the valve seats must be ground to ensure that the valve seat is concentric to the valve guide.

VALVE STEM-TO-GUIDE CLEARANCE MEASUREMENT

Valve stem-to-guide clearance may be measured by either of the following two methods.

PREFERRED METHOD

- (1) Remove the valve from the head.
- (2) Clean the valve stem guide bore with solvent and a bristle brush.
- (3) Insert a telescoping gauge into the valve stem guide bore approximately 9.525 mm (.375 inch) from the valve spring side of the head (Fig. 66).

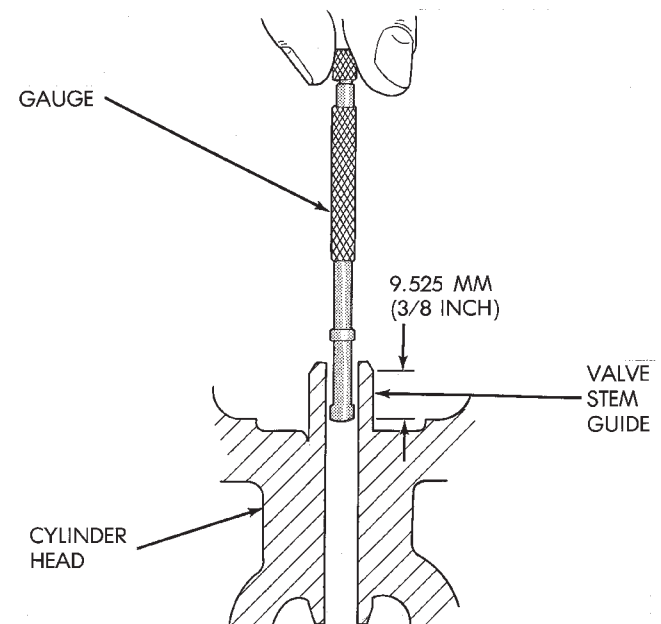


Fig. 66 Measurement of Valve Guide Bore Diameter

DISASSEMBLY AND ASSEMBLY (Continued)

(4) Remove and measure telescoping gauge with a micrometer.

(5) Repeat the measurement with contacts lengthwise to engine cylinder head.

(6) Compare the crosswise to lengthwise measurements to determine out-of-roundness. If the measurements differ by more than 0.0635 mm (0.0025 in.), ream the guide bore to accommodate an oversize valve stem.

(7) Compare the measured valve guide bore diameter with specifications (7.95-7.97 mm or 0.313-0.314 inch). If the measurement differs from specification by more than 0.076 mm (0.003 inch), ream the guide bore to accommodate an oversize valve stem.

ALTERNATIVE METHOD

(1) Use a dial indicator to measure the lateral movement of the valve stem (stem-to-guide clearance). This must be done with the valve installed in its guide and just off the valve seat (Fig. 67).

(2) Correct clearance is 0.025-0.0762 mm (0.001-0.003 inch). If indicated movement exceeds the specification ream the valve guide to accommodate an oversize valve stem.

NOTE: Valve seats must be ground after reaming the valve guides to ensure that the valve seat is concentric to the valve guide.

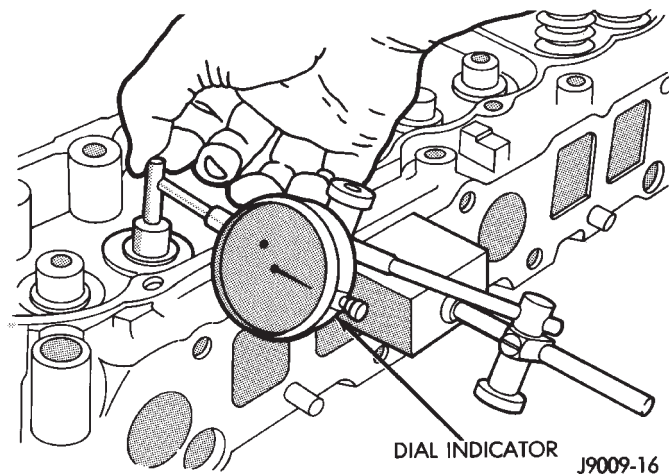
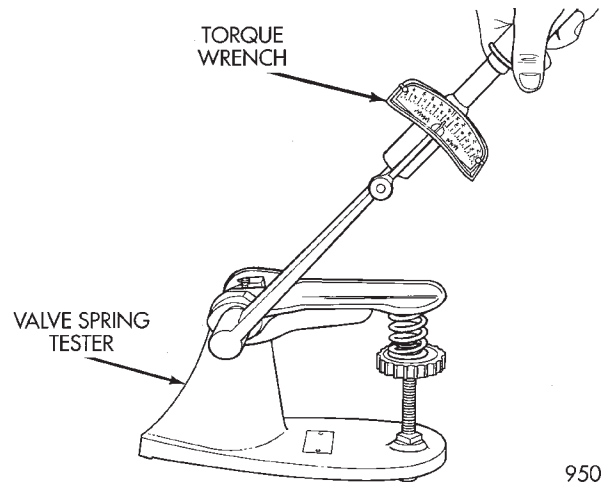


Fig. 67 Measurement of Lateral Movement of Valve Stem

VALVE SPRING TENSION TEST

Use a universal Valve Spring Tester and a torque wrench to test each valve spring for the specified tension value (Fig. 68).

Replace valve springs that are not within specifications.



9509-79

Fig. 68 Valve Spring Tester

CYLINDER BLOCK

DISASSEMBLY

Refer to the applicable sections for detailed instructions.

- (1) Drain the engine oil. Remove and discard the oil filter.
- (2) Remove the water pump from the cylinder block.
- (3) Remove the vibration damper.
- (4) Remove the timing case cover and lay the cover upside down.
- (5) Position a drift punch into the slot in the back of the cover and tap the old seal out.
- (6) Remove the oil slinger from crankshaft.
- (7) Remove the camshaft retaining bolt and remove the sprockets and chain as an assembly.
- (8) Remove the camshaft.
- (9) Remove the oil pan and gasket.
- (10) Remove the front and rear oil galley plugs.
- (11) Remove the oil pump.
- (12) Remove the connecting rods and the pistons. Remove the connecting rod and piston assemblies through the top of the cylinder bores.
- (13) Remove the crankshaft.

ASSEMBLY

Refer to the applicable sections for detailed instructions.

- (1) Install the crankshaft.
- (2) Install the connecting rods and the pistons through the top of the cylinder bores.
- (3) Install the oil pump.
- (4) Install the oil pan and gasket.
- (5) Install the camshaft.
- (6) Install the sprockets and chain as an assembly.
- (7) Install the oil slinger from the crankshaft.
- (8) Install the timing case cover seal.
- (9) Install the timing case cover.

DISASSEMBLY AND ASSEMBLY (Continued)

- (10) Install the vibration damper.
- (11) Install the water pump. Tighten the mounting bolts to 31 N·m (23 ft. lbs.) torque.
- (12) Lubricate the oil filter seal with clean engine oil. Tighten oil filter to 18 N·m (156 in. lbs.) torque.
- (13) Install the engine into the vehicle.
- (14) Fill the engine with clean lubrication oil (refer to Group 0, Lubrication and Maintenance).
- (15) Fill the cooling system.

CLEANING AND INSPECTION

CYLINDER HEAD

CLEANING

Thoroughly clean the engine cylinder head and cylinder block mating surfaces. Clean the intake and engine exhaust manifold and engine cylinder head mating surfaces. Remove all gasket material and carbon.

Check to ensure that no coolant or foreign material has fallen into the tappet bore area.

Remove the carbon deposits from the combustion chambers and top of the pistons.

INSPECTION

Use a straightedge and feeler gauge to check the flatness of the engine cylinder head and block mating surfaces.

CYLINDER HEAD COVER

CLEANING

Remove any original sealer from the cover sealing surface of the engine cylinder head and clean the surface using a fabric cleaner.

Remove all residue from the sealing surface using a clean, dry cloth.

INSPECTION

Inspect the engine cylinder head cover for cracks. Replace the cover, if cracked.

The original dark grey gasket material should NOT be removed. If sections of the gasket material are missing or are compressed, replace the engine cylinder head cover. However, sections with minor damage such as small cracks, cuts or chips may be repaired with a hand held applicator. The new material must be smoothed over to maintain gasket height. Allow the gasket material to cure prior to engine cylinder head cover installation.

ROCKER ARMS AND PUSH RODS

CLEANING

Clean all the components with cleaning solvent.

Use compressed air to blow out the oil passages in the rocker arms and push rods.

INSPECTION

Inspect the pivot surface area of each rocker arm. Replace any that are scuffed, pitted, cracked or excessively worn.

Inspect the valve stem tip contact surface of each rocker arm and replace any rocker arm that is deeply pitted.

Inspect each push rod end for excessive wear and replace as required. If any push rod is excessively worn because of lack of oil, replace it and inspect the corresponding hydraulic tappet for excessive wear.

Inspect the push rods for straightness by rolling them on a flat surface or by shining a light between the push rod and the flat surface.

A wear pattern along the length of the push rod is not normal. Inspect the engine cylinder head for obstruction if this condition exists.

HYDRAULIC TAPPETS

CLEANING

Clean each tappet assembly in cleaning solvent to remove all varnish, gum and sludge deposits.

INSPECTION

Inspect for indications of scuffing on the side and base of each tappet body.

Inspect each tappet base for concave wear with a straightedge positioned across the base. If the base is concave, the corresponding lobe on the camshaft is also worn. Replace the camshaft and defective tappets.

LEAK-DOWN TEST

After cleaning and inspection, test each tappet for specified leak-down rate tolerance to ensure zero-lash operation (Fig. 69).

Swing the weighted arm of the hydraulic valve tappet tester away from the ram of the Leak-Down Tester.

(1) Place a 7.925-7.950 mm (0.312-0.313 inch) diameter ball bearing on the plunger cap of the tappet.

(2) Lift the ram and position the tappet (with the ball bearing) inside the tester cup.

(3) Lower the ram, then adjust the nose of the ram until it contacts the ball bearing. DO NOT tighten the hex nut on the ram.

(4) Fill the tester cup with hydraulic valve tappet test oil until the tappet is completely submerged.

(5) Swing the weighted arm onto the push rod and pump the tappet plunger up and down to remove air. When the air bubbles cease, swing the weighted arm

CLEANING AND INSPECTION (Continued)

away and allow the plunger to rise to the normal position.

(6) Adjust the nose of the ram to align the pointer with the SET mark on the scale of the tester and tighten the hex nut.

(7) Slowly swing the weighted arm onto the push rod.

(8) Rotate the cup by turning the handle at the base of the tester clockwise one revolution every 2 seconds.

(9) Observe the leak-down time interval from the instant the pointer aligns with the START mark on the scale until the pointer aligns with the 0.125 mark. A normally functioning tappet will require 20-110 seconds to leak-down. Discard tappets with leak-down time interval not within this specification.

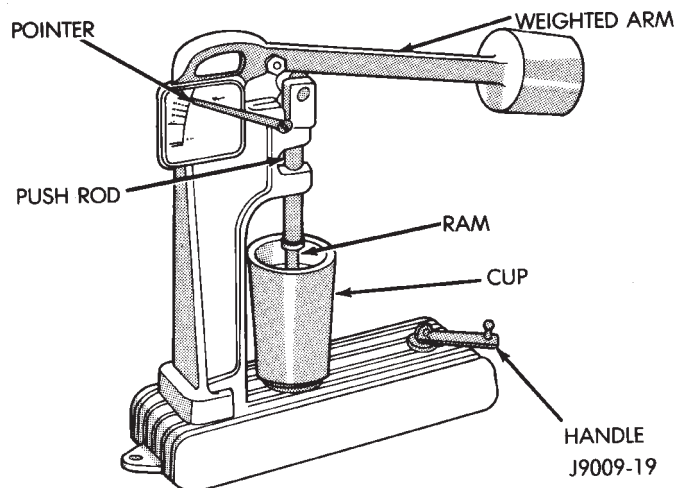


Fig. 69 Leak-Down Tester

CYLINDER BLOCK

CLEANING

Thoroughly clean the oil pan and engine block gasket surfaces.

Use compressed air to clean out:

- The galley at the oil filter adaptor hole.
- The front and rear oil galley holes.
- The feed holes for the crankshaft main bearings.

Once the block has been completely cleaned, apply Loctite PST pipe sealant with Teflon 592 to the threads of the front and rear oil galley plugs. Tighten the plugs to 34 N·m (25 ft. lbs.) torque.

INSPECTION—CYLINDER BORE

(1) It is mandatory to use a dial bore gauge to measure each cylinder bore diameter (Fig. 70). To correctly select the proper size piston, a cylinder bore gauge, capable of reading in 0.003 mm (.0001 in.) INCREMENTS is required. If a bore gauge is not available, do not use an inside micrometer.

(2) Measure the inside diameter of the cylinder bore at three levels below top of bore. Start perpen-

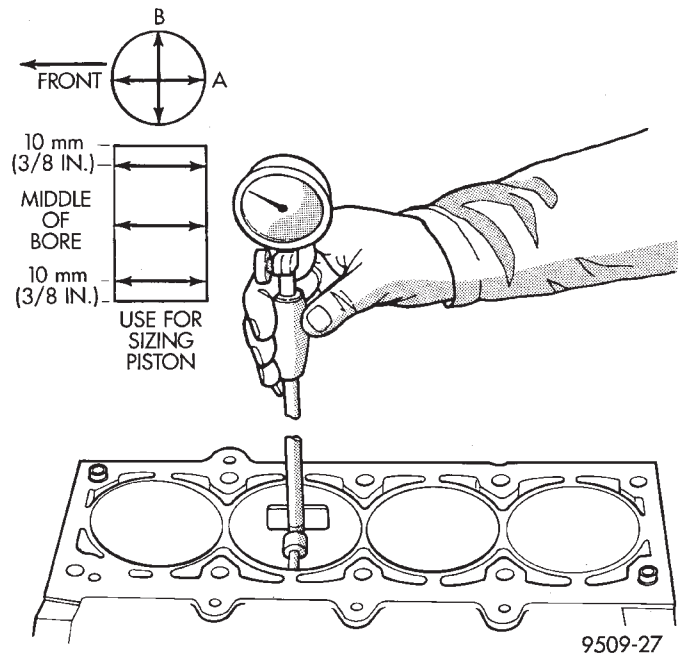


Fig. 70 Cylinder Bore Measurement

dicular (across or at 90 degrees) to the axis of the crankshaft and then take two additional readings.

(3) Measure the cylinder bore diameter crosswise to the cylinder block near the top of the bore. Repeat the measurement near the middle of the bore, then repeat the measurement near the bottom of the bore.

(4) Determine taper by subtracting the smaller diameter from the larger diameter.

(5) Rotate measuring device 90° and repeat steps above.

(6) Determine out-of-roundness by comparing the difference between each measurement.

(7) If cylinder bore taper does not exceed 0.025 mm (0.001 inch) and out-of-roundness does not exceed 0.025 mm (0.001 inch), the cylinder bore can be honed. If the cylinder bore taper or out-of-round condition exceeds these maximum limits, the cylinder must be bored and then honed to accept an oversize piston. A slight amount of taper always exists in the cylinder bore after the engine has been in use for a period of time.

HONING—CYLINDER BORE

The honing operation should be closely coordinated with the fitting of pistons and rings. This will ensure specified clearances are maintained.

Refer to Standard Service Procedures in the beginning of this Group for the proper honing of cylinder bores.

SPECIFICATIONS

4.0L ENGINE SPECIFICATIONS

4.0L Engine Description

Engine Type	In-line 6 Cylinder
Bore and Stroke	.98.4 x 86.69 mm (3.88 x 3.413 in.)
Displacement	.4.0L (242 cu. in.)
Compression Ratio	.8.8:1
Firing Order	.1-5-3-6-2-4
Lubrication	.Pressure Feed-Full Flow Filtration
Cooling System	.Liquid Cooled-Forced Circulation
Cylinder Block	.Cast Iron
Crankshaft	.Cast Nodular Iron
Cylinder Head	.Cast Iron
Camshaft	.Cast Iron
Pistons	.Aluminum Alloy (w/struts)
Combustion Chamber	.Dual-Quench
Connecting Rods	.Cast Malleable Iron

4.0L Engine Specifications

Camshaft

Hydraulic Tappet Clearance	.Zero Lash
Bearing Clearance	.0.025 to 0.076 mm (0.001 to 0.003 in.)

Bearing Journal Diameter

No. 1	.51.54 to 51.56 mm (2.029 to 2.030 in.)
No. 2	.51.28 to 51.31 mm (2.019 to 2.020 in.)
No. 3	.51.03 to 51.05 mm (2.009 to 2.010 in.)
No. 4	.50.78 to 50.80 mm (1.999 to 2.000 in.)
Base Circle Runout	.0.03 mm - max. (0.001 in. - max.)
Valve Lift	.10.29 mm (0.405 in.)

Intake Valve Timing

Opens	.12.4° BTDC
Closes	.60.9° ABDC

Exhaust Valve Timing

Opens	.49.8 BBDC
Closes	.29.2° ATDC
Valve Overlap	.41.6°
Intake Duration	.253.3°
Exhaust Duration	.259.°

Crankshaft

End Play	.0.038 to 0.165 mm (0.0015 to 0.0065 in.)
Main Bearing Journal Diameter No. 1-6	.63.489 to 63.502 mm (2.4996 to 2.5001 in.)
Main Bearing Journal Diameter No. 7	.63.449 to 63.487 mm (2.4980 to 2.4995 in.)
Main Bearing Journal Width No. 1	.27.58 to 27.89 mm (1.086 to 1.098 in.)

Main Bearing Journal Width No. 3	.32.28 to 32.33 mm (1.271 to 1.273 in.)
-------------------------------------	--

Main Bearing Journal Width No. 2-4-5-6-7	.30.02 to 30.18 mm (1.182 to 1.188 in.)
---	--

Main Bearing Clearance	.0.03 to 0.06 mm (0.001 to 0.0025 in.)
------------------------	---

Main Bearing Clearance (Preferred)	.0.051 mm (0.002 in.)
------------------------------------	--------------------------

Connecting Rod Journal Diameter	.53.17 to 53.23 mm (2.0934 to 2.0955 in.)
------------------------------------	--

Connecting Rod Journal Width	.27.18 to 27.33 mm (1.070 to 1.076 in.)
------------------------------	--

Out-of-Round (Max. All Journals)	.0.013 mm (0.0005 in.)
----------------------------------	---------------------------

Taper (Max. - All Journals)	.0.013 mm (0.0005 in.)
-----------------------------	---------------------------

Cylinder Block

Deck Height	.240.03 to 240.18 mm (9.450 to 9.456 in.)
-------------	--

Deck Clearance (Below Block)	.0.546 mm (0.0215 in.)
------------------------------	---------------------------

Cylinder Bore Diameter— Standard	.98.45 to 98.48 mm (3.8759 to 3.8775 in.)
-------------------------------------	--

Cylinder Bore Diameter— Taper (Max.)	.0.025 mm (0.001 in.)
---	-----------------------

Cylinder Bore Diameter— Out-of-Round	.0.025 mm (0.001 in.)
---	--------------------------

Tappet Bore Diameter	.23.000 to 23.025 mm (0.9055 to 0.9065 in.)
----------------------	--

Flatness	.0.03 mm per 25 mm (0.001 in. per 1 in.)
----------	---

Flatness	.0.05 mm per 152 mm (0.002 in. per 6 in.)
----------	--

Flatness Max.	.0.20 mm max. for total length (0.008 in. max. for total length)
---------------	---

Main Bearing Bore Diameter	.68.3514 to 68.3768 mm (2.691 to 2.692 in.)
-------------------------------	--

Connecting Rods

Total Weight (Less Bearing)	.657 to 665 grams (23.17 to 23.45 oz.)
-----------------------------	---

Length (Center-to-Center)	.155.52 to 155.62 mm (6.123 to 6.127 in.)
---------------------------	--

Piston Pin Bore Diameter	.23.59 to 23.62 mm (0.9288 to 0.9298 in.)
--------------------------	--

Bore (Less Bearings)	.56.08 to 56.09 mm (2.2080 to 2.2085 in.)
----------------------	--

Bearing Clearance	.0.025 to 0.076 mm (0.001 to 0.003 in.)
-------------------	--

Bearing Clearance (Preferred)	.0.044 to 0.050 mm (0.0015 to 0.0020 in.)
-------------------------------	--

SPECIFICATIONS (Continued)

Side Clearance0.25 to 0.48 mm
 (0.010 to 0.019 in.)
 Twist (Max.)0.001 mm per mm
 (0.001 in. per inch)
 Bend (Max.)0.001 mm per mm
 (0.001 in. per inch.)

Cylinder Compression Pressure

Ratio8.7:1
 Pressure Range827 to 1,034 kPa
 (120 to 150 psi)
 Max. Variation Between Cylinders206 kPa
 (30 psi)

Cylinder Head

Combustion Chamber52.22 to 58.22 cc
 (3.37 to 3.55 cu. in.)
 Valve Guide I.D. (Integral)7.95 to 7.97 mm
 (0.313 to 0.314 in.)
 Valve Stem-to-Guide Clearance .0.025 to 0.076 mm
 (0.001 to 0.003 in.)
 Intake Valve Seat Angle44.5°
 Exhaust Valve Seat Angle44.5°
 Valve Seat Width1.02 to 1.52 mm
 (0.040 to 0.060 in.)
 Valve Seat Runout0.064 mm (0.0025 in.)
 Flatness0.03 mm per 25 mm
 (0.001 in. per 1 in.)
 Flatness0.05 mm per 152 mm
 (0.002 in. per 6 in.)
 Flatness Max.0.20 mm - max. for total length
 (0.008 in. max. for total length)

Rocker Arms, Push Rods & Tappets

Rocker Arm Ratio1.6:1
 Push Rod Length244.856 to 245.364 mm
 (9.640 to 9.660 in.)
 Push Rod Diameter7.92 to 8.00 mm
 (0.312 to 0.315 in.)
 Hydraulic Tappet Diameter . .22.962 to 22.974 mm
 (0.904 to 0.9045 in.)
 Tappet-to-Bore Clearance0.025 to 0.063 mm
 (0.001 to 0.0025 in.)

Valves

Length (Tip-to-Gauge Dimension Line)
 Intake122.479 to 122.860 mm
 (4.822 to 4.837 in.)
 Length (Tip-to-Gauge Dimension Line)
 Exhaust122.860 to 123.241 mm
 (4.837 to 4.852 in.)
 Valve Stem Diameter7.899 to 7.925 mm
 (0.311 to 0.312 in.)
 Stem-to-Guide Clearance0.025 to 0.076 mm
 (0.001 to 0.003 in.)
 Valve Head Diameter—
 Intake48.387 to 48.641 mm
 (1.905 to 1.915 in.)

Valve Head Diameter—
 Exhaust.37.973 to 38.227 mm (1.495 to 1.505 in.)
 Valve Face Angle—Intake45°
 Valve Face Angle—Exhaust45°
 Tip Refinishing (Max. Allowable)0.25 mm
 (0.010 in.)

Valve Springs

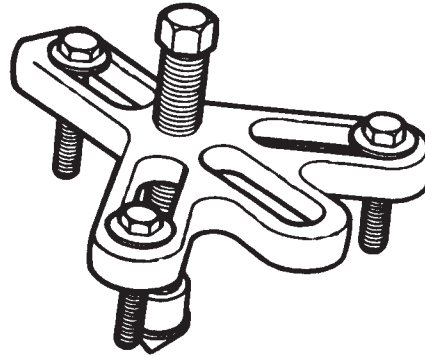
Free Length (Approx.)47.65 mm (1.876 in.)
 Spring Tension—Valve
 Closed271 to 307 N @ 41.656 mm
 (61 to 69 lbf. @ 1.64 in.)
 Spring Tension—Valve Open . . .818.5 to 871.9 N @
 30.89 mm
 (184 to 196 lbf @ 1.216 in.)
 Inside Diameter21.0 mm to 21.51 mm
 (0.827 to 0.847 in.)

Pistons

Weight (Less Pin)563 to 567 grams
 (19.86 to 20.00 oz.)
 Piston Pin Bore
 (Centerline to Piston Top)40.61 to 40.72 mm
 (1.599 to 1.603 in.)
 Piston-to-Bore Clearance0.033 to 0.053 mm
 (0.0013 to 0.0021 in.)
 Piston-to-Bore Clearance
 (Preferred)0.033 to 0.038 mm
 (0.0013 to 0.0015 in.)
 Ring Gap Clearance—
 Top Compression Ring0.229 to 0.610mm
 (0.0090 to 0.0240 in.)
 Ring Gap Clearance—
 2nd Compression Ring0.483 to 0.965 mm
 (0.0190 to 0.0380 in.)
 Ring Gap Clearance—
 Oil Control Steel Rails0.254 to 1.500 mm
 (0.010 to 0.060 in.)
 Ring Side Clearance—
 Compression Rings0.042 to 0.084 mm
 (0.0017 to 0.0033 in.)
 Ring Side Clearance—
 Oil Control Rings0.06 to 0.21 mm
 (0.0024 to 0.0083 in.)
 Piston Ring Groove Height—
 Compression Rings1.530 to 1.555 mm
 (0.0602 to 0.0612 in.)
 Piston Ring Groove Height—
 Oil Control Ring4.035 to 4.060 mm
 (0.1589 to 0.1598 in.)
 Piston Ring Groove Diameter—
 Compression Rings88.3 to 88.55 mm
 (3.476 to 3.486 in.)
 Piston Ring Groove Diameter—
 Oil Control Ring90.35 to 90.60 mm
 (3.557 to 3.566 in.)
 Piston Pin Bore Diameter . . .23.647 to 23.655 mm
 (0.9310 to 0.9313 in.)

SPECIFICATIONS (Continued)

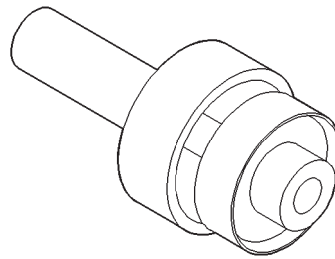
- Piston Pin Diameter 23.637 to 23.640 mm
(0.9306 to 0.9307 in.)
- Piston-to-Pin Clearance . . .0.0076 to 0.0178 mm—
Loose (0.0003 to 0.0007 in. Loose)
- Piston-to-Pin Clearance (Preferred)0.013 mm
(0.0005 in.)
- Piston-to-Pin Connecting Rod (Press Fit) . . .8.9 kN
(2000 lbf.)



Vibration Damper Removal Tool 7697

Oil Pump

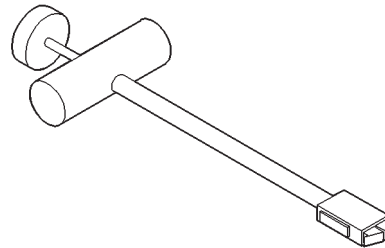
- Gear-to-Body Clearance
(Radial) 0.051 to 0.102 mm
(0.002 to 0.004 in.)
- Gear-to-Body Clearance
(Radial) (Preferred) 0.051 mm (0.002 in.)
- Gear End Clearance—
Plastigage . .0.051 to 0.152 mm (0.002 to 0.006 in.)
- Gear End Clearance—
Plastigage (Preferred) 0.051 mm (0.002 in.)
- Gear End Clearance—
Feeler Gauge 0.1016 to 0.2032 mm
(0.004 to 0.008 in.)
- Gear End Clearance—
Feeler Gauge (Preferred) . . . 0.1778 mm (0.007 in.)



Rear Main Seal Installer Tool 6271A

Oil Pressure

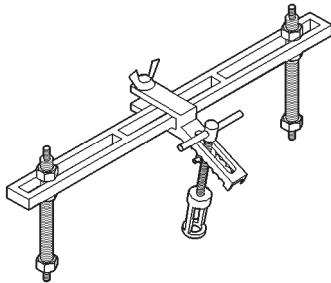
- At Idle Speed (600 rpm) 89.6 kPa (13 psi)
- At 1600 rpm & Higher 255 to 517 kPa
(37 to 75 psi)
- Oil Pressure Relief 517 kPa (75 psi)



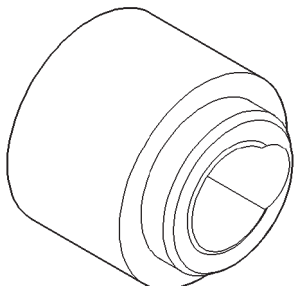
**Hydraulic Valve Tappet Removal/Installation Tool
C-4129-A**

SPECIAL TOOLS

4.0L ENGINE



Valve Spring Compressor Tool MD-998772A



**Timing Case Cover Alignment and Seal installation
Tool 6139**

5.2L ENGINE

INDEX

	page		page
GENERAL INFORMATION			
OIL PUMP PRESSURE	55	ENGINE MOUNT—REAR	62
PISTON AND CONNECTING ROD ASSEMBLY ..	55	HYDRAULIC TAPPETS	66
VALVES AND VALVE SPRINGS	55	OIL PAN	71
DESCRIPTION AND OPERATION			
ENGINE COMPONENTS	58	OIL PUMP	73
ENGINE DESCRIPTION	55	PISTON AND CONNECTING ROD ASSEMBLY ..	72
LUBRICATION SYSTEM	56	ROCKER ARMS AND PUSH RODS	64
SERVICE PROCEDURES			
CRANKSHAFT MAIN BEARINGS	60	TIMING CHAIN COVER	66
CRANKSHAFT	60	TIMING CHAIN	68
FITTING CONNECTING ROD BEARINGS	60	VALVE SPRING AND STEM SEAL	
FITTING PISTON RINGS	59	REPLACEMENT-IN VEHICLE	64
FITTING PISTONS	59	VALVES AND VALVE SPRINGS	65
MEASURING TIMING CHAIN STRETCH	58	VIBRATION DAMPER	66
VALVE TIMING	58	DISASSEMBLY AND ASSEMBLY	
REMOVAL AND INSTALLATION			
CAMSHAFT BEARINGS	69	CYLINDER BLOCK	79
CAMSHAFT	68	HYDRAULIC TAPPETS	77
CRANKSHAFT MAIN BEARINGS	70	OIL PUMP	79
CRANKSHAFT OIL SEAL — FRONT	74	VALVE SERVICE	77
CRANKSHAFT OIL SEALS — REAR	74	CLEANING AND INSPECTION	
CRANKSHAFT	73	CRANKSHAFT JOURNALS	80
CYLINDER HEAD COVER	63	CYLINDER BLOCK	82
CYLINDER HEAD	64	CYLINDER HEADS	79
DISTRIBUTOR DRIVE SHAFT BUSHING	70	OIL PAN	80
ENGINE ASSEMBLY	62	OIL PUMP	80
ENGINE CORE OIL AND CAMSHAFT PLUGS ..	76	PISTON AND CONNECTING ROD ASSEMBLY ..	80
ENGINE MOUNTS—FRONT	61	SPECIFICATIONS	
		5.2L ENGINE SPECIFICATIONS	83
		5.2L TORQUE SPECIFICATIONS	85
		SPECIAL TOOLS	
		5.2L ENGINE	86

GENERAL INFORMATION

VALVES AND VALVE SPRINGS

The valves are arranged in-line and inclined 18°. The rocker pivot support and the valve guides are cast integral with the heads.

OIL PUMP PRESSURE

The MINIMUM oil pump pressure is 41.4 kPa (6 psi) at curb idle. The MAXIMUM oil pump pressure is 207-552 kPa (30-80 psi) at 3,000 RPM or more.

CAUTION: If oil pressure is ZERO at curb idle, DO NOT run engine.

PISTON AND CONNECTING ROD ASSEMBLY

The pistons are elliptically turned so that the diameter at the pin boss is less than its diameter

across the thrust face. This allows for expansion under normal operating conditions. Under operating temperatures, expansion forces the pin bosses away from each other, causing the piston to assume a more nearly round shape.

All pistons are machined to the same weight, regardless of size, to maintain piston balance.

The piston pin rotates in the piston only and is retained by the press interference fit of the piston pin in the connecting rod.

DESCRIPTION AND OPERATION

ENGINE DESCRIPTION

The 5.2 Liter (318 CID) eight-cylinder engine is a V-Type lightweight, single cam, overhead valve engine with hydraulic roller tappets.

This engine is designed for unleaded fuel.

DESCRIPTION AND OPERATION (Continued)

Engine lubrication system consists of a rotor type oil pump and a full flow oil filter.

The cylinders are numbered from front to rear; 1, 3, 5, 7 on the left bank and 2, 4, 6, 8 on the right bank. The firing order is 1-8-4-3-6-5-7- 2 (Fig. 1).

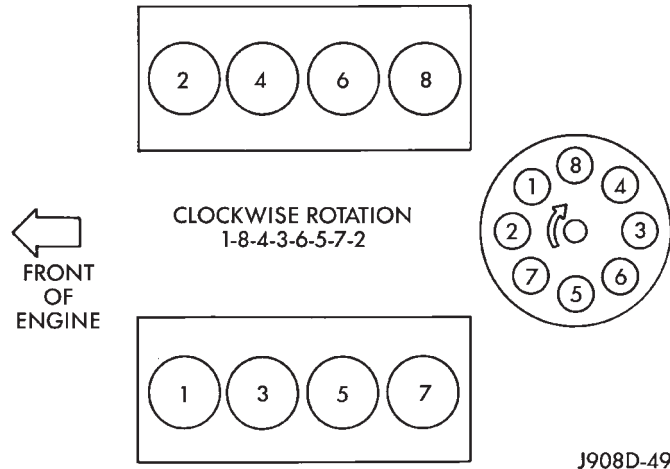


Fig. 1 Firing Order

The engine serial number is stamped into a machined pad located on the left, front corner of the cylinder block. When component part replacement is necessary, use the engine type and serial number for reference (Fig. 2).

LUBRICATION SYSTEM

A gear-type positive displacement pump is mounted at the underside of the rear main bearing cap. The pump draws oil through the screen and inlet tube from the sump at the rear of the oil pan. The oil is driven between the drive and idler gears and pump body, then forced through the outlet to the block. An oil gallery in the block channels the oil to the inlet side of the full flow oil filter. After passing through the filter element, the oil passes from the center outlet of the filter through an oil gallery that channels the oil up to the main gallery which extends the entire length on the right side of the block. The oil then goes down to the No. 1 main bear-



X = Last Digit of Model Year
 M = Plant - M Mound Road
 S Saltillo
 T Trenton
 K Toluca
 5.2L = Engine Displacement
 T = Usage - T Truck
 XXXX = Month/Day
 XXXXXXXX = Serial Code - Last 8 Digits of VIN No.

J9209-73

Fig. 2 Engine Identification Number

ing, back up to the left side of the block and into the oil gallery on the left side of the engine.

Galleries extend downward from the main oil gallery to the upper shell of each main bearing. The crankshaft is drilled internally to pass oil from the main bearing journals to the connecting rod journals. Each connecting rod bearing has half a hole in it, oil passes through the hole when the rods rotate and the hole lines up, oil is then thrown off as the rod rotates. This oil throw off lubricates the camshaft lobes, distributor drive gear, cylinder walls, and piston pins.

The hydraulic valve tappets receive oil directly from the main oil gallery. The camshaft bearings receive oil from the main bearing galleries. The front camshaft bearing journal passes oil through the camshaft sprocket to the timing chain. Oil drains back to the oil pan under the number one main bearing cap.

The oil supply for the rocker arms and bridged pivot assemblies is provided by the hydraulic valve tappets which pass oil through hollow push rods to a hole in the corresponding rocker arm. Oil from the rocker arm lubricates the valve train components. The oil then passes down through the push rod guide holes, and the oil drain back passages in the cylinder head past the valve tappet area, and returns to the oil pan.

DESCRIPTION AND OPERATION (Continued)

80183-4a9

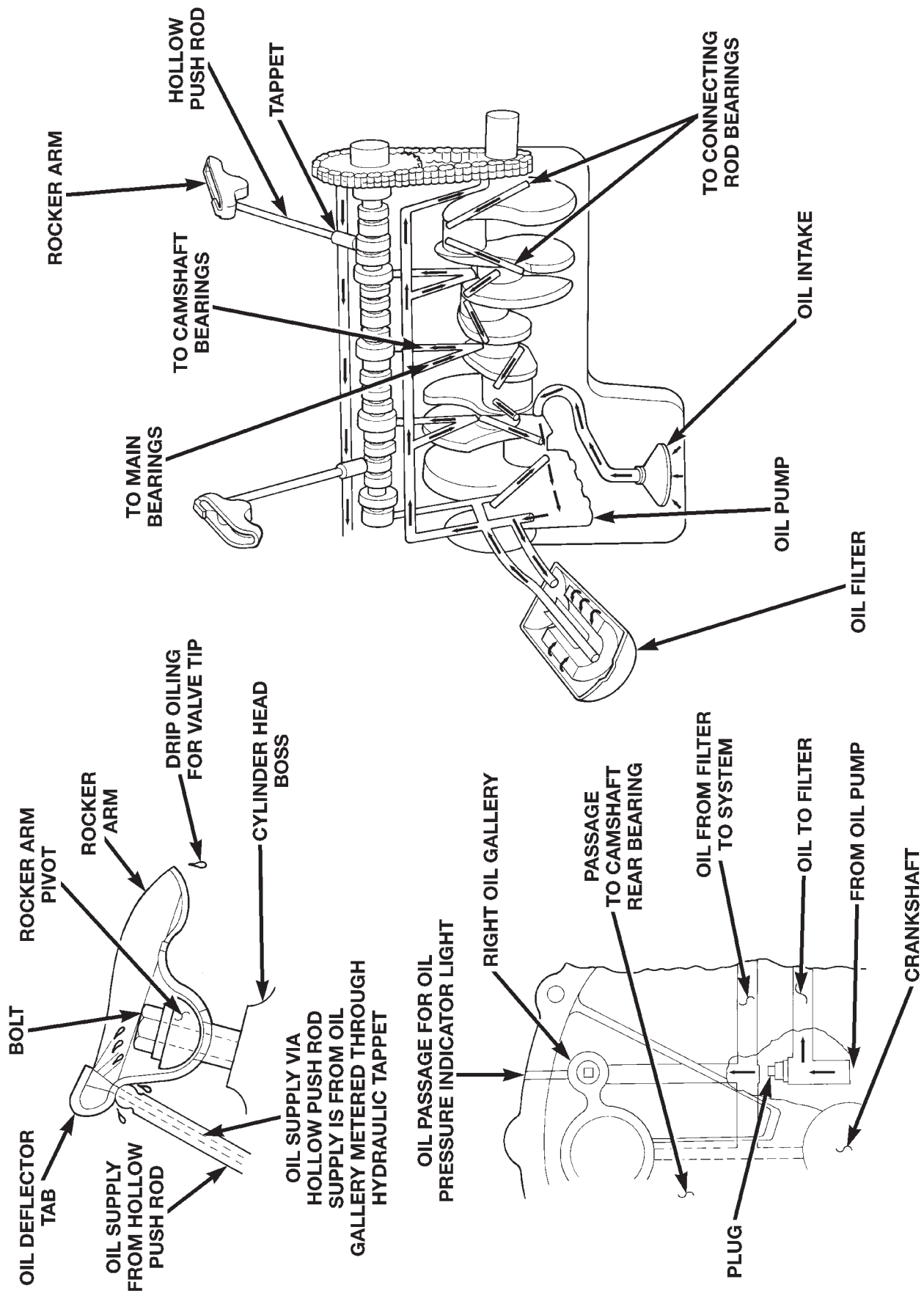


Fig. 3 Oil Lubrication System

DESCRIPTION AND OPERATION (Continued)

ENGINE COMPONENTS

CYLINDER HEAD

The alloy cast iron cylinder heads (Fig. 4) are held in place by 10 bolts. The spark plugs are located in the peak of the wedge between the valves.

The 5.2L cylinder head is identified by the foundry mark NH.

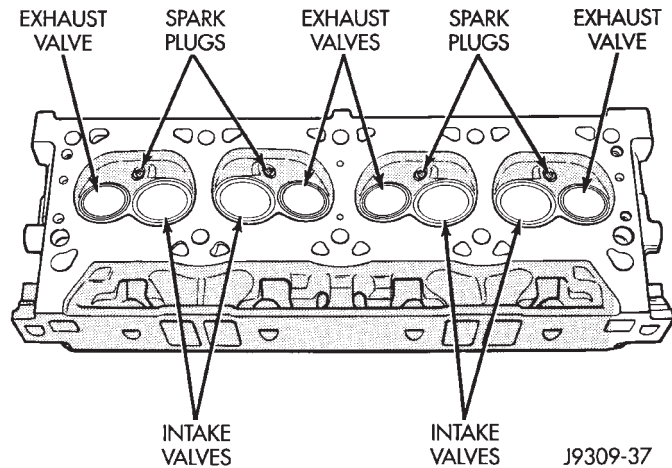


Fig. 4 Cylinder Head Assembly

PISTONS

All pistons are machined to the same weight, regardless of size, to maintain piston balance.

The pistons are elliptically turned so that the diameter at the pin boss is less than its diameter across the thrust face. This allows for expansion under normal operating conditions. Under operating temperatures, expansion forces the pin bosses away from each other, causing the piston to assume a more nearly round shape.

The piston pin rotates in the piston only and is retained by the press interference fit of the piston pin in the connecting rod.

SERVICE PROCEDURES

VALVE TIMING

(1) Turn crankshaft until the No.6 exhaust valve is closing and No.6 intake valve is opening.

(2) Insert a 6.350 mm (1/4 inch) spacer between rocker arm pad and stem tip of No.1 intake valve. Allow spring load to bleed tappet down giving in effect a solid tappet.

(3) Install a dial indicator so plunger contacts valve spring retainer as nearly perpendicular as possible. Zero the indicator.

(4) Rotate the crankshaft clockwise (normal running direction) until the valve has lifted 0.863 mm (0.034 inch). The timing of the crankshaft should

now read from 10° before top dead center to 2° after top dead center. Remove spacer.

CAUTION: DO NOT turn crankshaft any further clockwise as valve spring might bottom and result in serious damage.

If reading is not within specified limits:

- Check sprocket index marks.
- Inspect timing chain for wear.
- Check accuracy of DC mark on timing indicator.

MEASURING TIMING CHAIN STRETCH

NOTE: To access timing chain Refer to Timing Chain Cover in Removal and Installation Section.

(1) Place a scale next to the timing chain so that any movement of the chain may be measured.

(2) Place a torque wrench and socket over camshaft sprocket attaching bolt. Apply torque in the direction of crankshaft rotation to take up slack; 41 N·m (30 ft. lbs.) torque with cylinder head installed or 20 N·m (15 ft. lbs.) torque with cylinder head removed. With a torque applied to the camshaft sprocket bolt, crankshaft should not be permitted to move. It may be necessary to block the crankshaft to prevent rotation.

(3) Hold a scale with dimensional reading even with the edge of a chain link. With cylinder heads installed, apply 14 N·m (30 ft. lbs.) torque in the reverse direction. With the cylinder heads removed, apply 20 N·m (15 ft. lbs.) torque in the reverse direction. Note the amount of chain movement (Fig. 5).

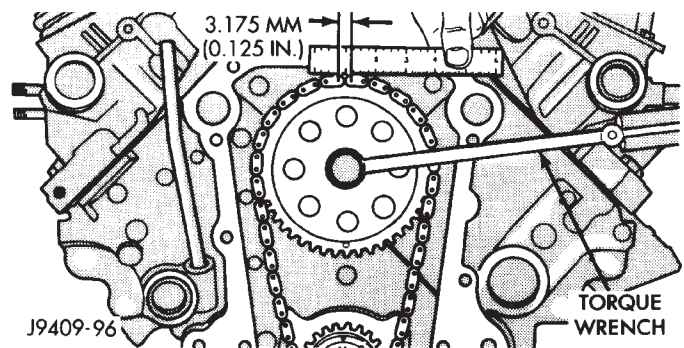


Fig. 5 Measuring Timing Chain Wear and Stretch

(4) Install a new timing chain, if its movement exceeds 3.175 mm (1/8 inch).

(5) If chain is not satisfactory, remove camshaft sprocket attaching bolt and remove timing chain with crankshaft and camshaft sprockets.

(6) Place both camshaft sprocket and crankshaft sprocket on the bench with timing marks on exact imaginary center line through both camshaft and crankshaft bores.

(7) Place timing chain around both sprockets.

SERVICE PROCEDURES (Continued)

(8) Turn crankshaft and camshaft to line up with keyway location in crankshaft sprocket and in camshaft sprocket.

(9) Lift sprockets and chain (keep sprockets tight against the chain in position as described).

(10) Slide both sprockets evenly over their respective shafts and use a straightedge to check alignment of timing marks (Fig. 6).

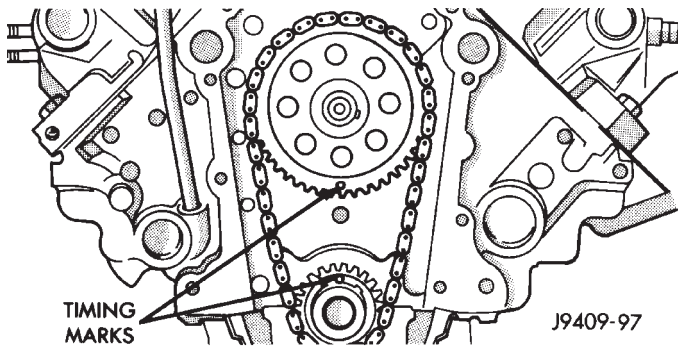


Fig. 6 Alignment of Timing Marks

(11) Install the camshaft bolt. Tighten the bolt to 47 N·m (35 ft. lbs.) torque.

(12) Check camshaft end play. The end play should be 0.051-0.152 mm (0.002-0.006 inch) with a new thrust plate and up to 0.254 mm (0.010 inch) with a used thrust plate. If not within these limits install a new thrust plate.

FITTING PISTONS

Piston and cylinder wall must be clean and dry. Specified clearance between the piston and the cylinder wall is 0.013-0.038 mm (0.0005-0.0015 inch) at 21°C (70°F).

Piston diameter should be measured at the top of skirt, 90° to piston pin axis location A in (Fig. 7). Cylinder bores should be measured halfway down the cylinder bore and transverse to the engine crankshaft center line.

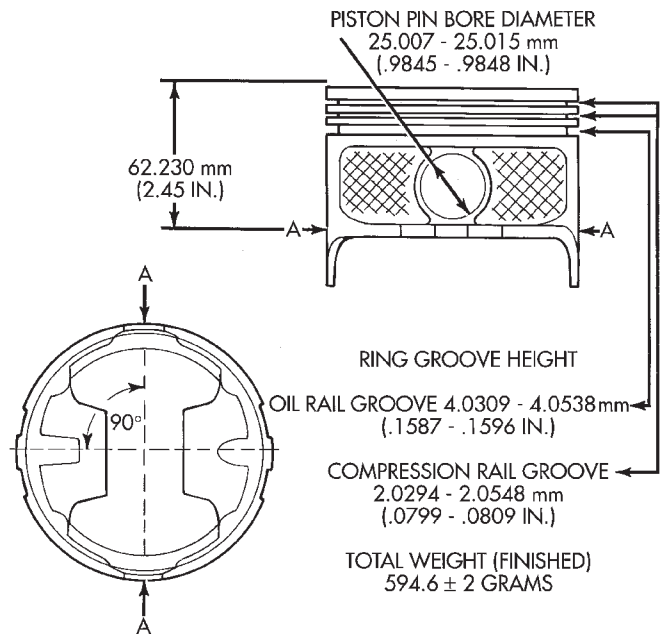
Pistons and cylinder bores should be measured at normal room temperature, 21°C (70°F).

FITTING PISTON RINGS

(1) Measurement of end gaps:

(a) Measure piston ring gap 2 inches from bottom of cylinder bore. An inverted piston can be used to push the rings down to ensure positioning rings squarely in the cylinder bore before measuring.

(b) Insert feeler gauge in the gap. The top compression ring gap should be between 0.254-0.508 mm (0.010-0.020 inch). The second compression ring gap should be between 0.508-0.762 mm (0.020-0.030 inch). The oil ring gap should be 0.254-1.270 mm (0.010-0.050 inch).



PISTON SIZE	A DIA = PISTON DIAMETER		BORE DIAMETER	
	MIN. mm (IN.)	MAX. mm (IN.)	MIN. mm (IN.)	MAX. mm (IN.)
A	99.280 (3.9087)	99.294 (3.9092)	99.306 (3.9097)	99.319 (3.9102)
B	99.294 (3.9092)	99.306 (3.9097)	99.319 (3.9102)	99.332 (3.9107)
C	99.306 (3.9097)	99.319 (3.9102)	99.332 (3.9107)	99.344 (3.9112)
D	99.319 (3.9102)	99.332 (3.9107)	99.344 (3.9112)	99.357 (3.9117)
E	99.332 (3.9107)	99.344 (3.9112)	99.357 (3.9117)	99.370 (3.9122)

J9509-80

Fig. 7 Piston Measurements

(c) Rings with insufficient end gap may be properly filed to the correct dimension. Rings with excess gaps should not be used.

(2) Install rings and confirm ring side clearance:

(a) Install oil rings being careful not to nick or scratch the piston. Install the oil control rings according to instructions in the package. It is not necessary to use a tool to install the upper and lower rails. Insert oil rail spacer first, then side rails.

(b) Install the second compression rings using Installation Tool C-4184. The compression rings must be installed with the identification mark face up (toward top of piston) and chamfer facing down. An identification mark on the ring is a drill point, a stamped letter "O", an oval depression or the word TOP (Fig. 8) (Fig. 10).

(c) Using a ring installer, install the top compression ring with the chamfer facing up (Fig. 9) (Fig. 10). An identification mark on the ring is a drill point, a stamped letter "O", an oval depression or the word TOP facing up.

(d) Measure side clearance between piston ring and ring land. Clearance should be 0.074-0.097 mm (0.0029-0.0038 inch) for the compression rings. The steel rail oil ring should be free in groove, but

SERVICE PROCEDURES (Continued)

should not exceed 0.246 mm (0.0097 inch) side clearance.

(e) Pistons with insufficient or excessive side clearance should be replaced.

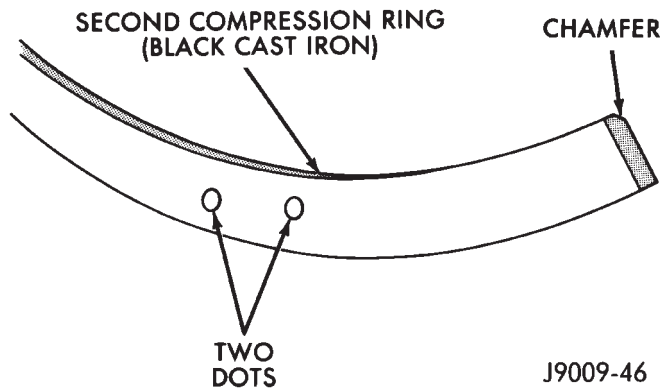


Fig. 8 Second Compression Ring Identification (Typical)

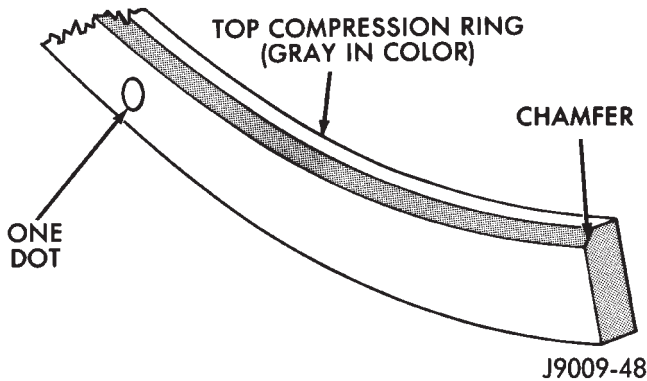


Fig. 9 Top Compression Ring Identification (Typical)

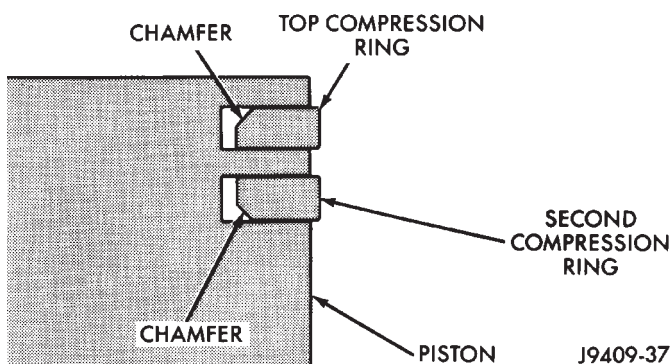


Fig. 10 Compression Ring Chamfer Location (Typical)

FITTING CONNECTING ROD BEARINGS

Fit all rods on a bank until completed. DO NOT alternate from one bank to another, because connecting rods and pistons are not interchangeable from one bank to another.

The bearing caps are not interchangeable and should be marked at removal to ensure correct assembly.

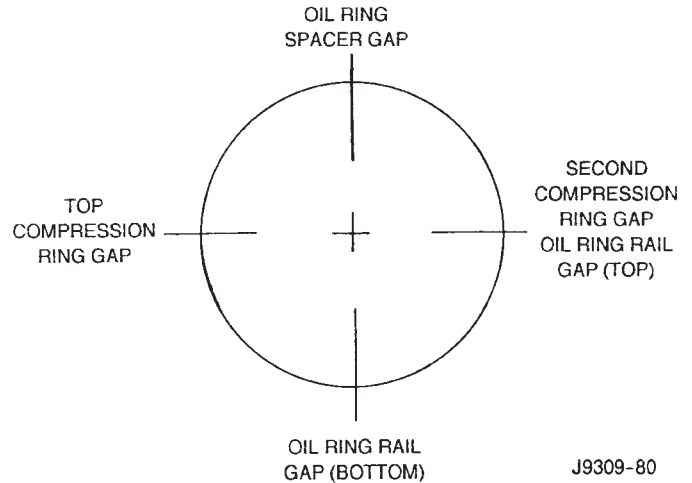


Fig. 11 Proper Ring Installation

Each bearing cap has a small V-groove across the parting face. When installing the lower bearing shell, make certain that the V-groove in the shell is in line with the V-groove in the cap. This provides lubrication of the cylinder wall in the opposite bank.

The bearing shells must be installed so that the tangs are in the machined grooves in the rods and caps.

Limits of taper or out-of-round on any crankshaft journals should be held to 0.025 mm (0.001 inch). Bearings are available in 0.025 mm (0.001 inch), 0.051 mm (0.002 inch), 0.076 mm (0.003 inch), 0.254 mm (0.010 inch) and 0.305 mm (0.012 inch) under-size. **Install the bearings in pairs. DO NOT use a new bearing half with an old bearing half. DO NOT file the rods or bearing caps.**

CRANKSHAFT MAIN BEARINGS

Bearing caps are not interchangeable and should be marked at removal to ensure correct assembly. Upper and lower bearing halves are NOT interchangeable. Lower main bearing halves of No.2 and 4 are interchangeable.

Upper and lower No.3 bearing halves are flanged to carry the crankshaft thrust loads. They are NOT interchangeable with any other bearing halves in the engine (Fig. 12). Bearing shells are available in standard and the following undersizes: 0.25 mm (0.001 inch), 0.051 mm (0.002 inch), 0.076 mm (0.003 inch), 0.254 mm (0.010 inch) and 0.305 mm (0.012 inch). Never install an under-size bearing that will reduce clearance below specifications.

CRANKSHAFT

A crankshaft which has under-size journals will be stamped with 1/4 inch letters on the milled flat on the No.8 crankshaft counterweight (Fig. 13).

FOR EXAMPLE: R2 stamped on the No.8 crankshaft counterweight indicates that the No.2 rod jour-

SERVICE PROCEDURES (Continued)

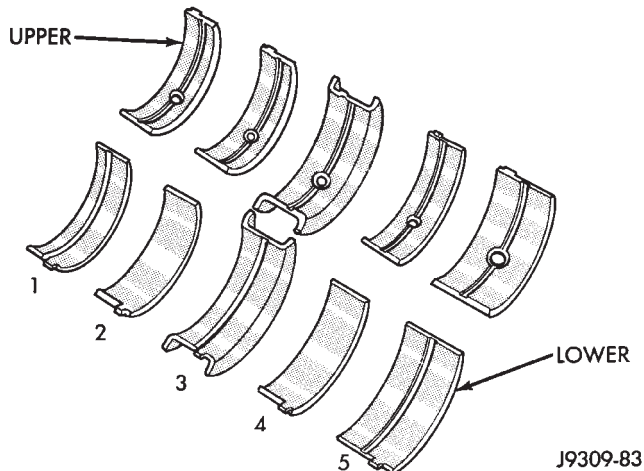


Fig. 12 Main Bearing Identification

nal is 0.025 mm (0.001 in) undersize. M4 indicates that the No.4 main journal is 0.025 mm (0.001 in) undersize. R3 M2 indicates that the No.3 rod journal and the No.2 main journal are 0.025 mm (0.001 in) undersize.

Undersize Journal	Identification Stamp
0.025 mm (0.001 in.) (Rod)	R1-R2-R3 or R4
0.025 mm (0.001 in.) (Main)	M1-M2-M3-M4 or M5

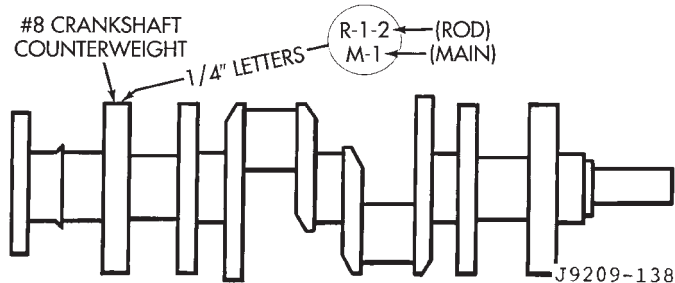


Fig. 13 Location of Crankshaft Identification

When a crankshaft is replaced, all main and connecting rod bearings should be replaced with new bearings. Therefore, selective fitting of the bearings is not required when a crankshaft and bearings are replaced.

REMOVAL AND INSTALLATION

ENGINE MOUNTS—FRONT

REMOVAL

- (1) Disconnect the negative cable from the battery.
- (2) Position fan to assure clearance for radiator top tank and hose.

CAUTION: DO NOT lift the engine by the intake manifold.

- (3) Install engine lifting fixture.
- (4) Raise vehicle on hoist.
- (5) Remove the engine support insulator thru-bolts and nuts (Fig. 14) (Fig. 15).
- (6) Raise engine SLIGHTLY. Remove the engine support insulator bolts. Remove the engine support insulator assembly.

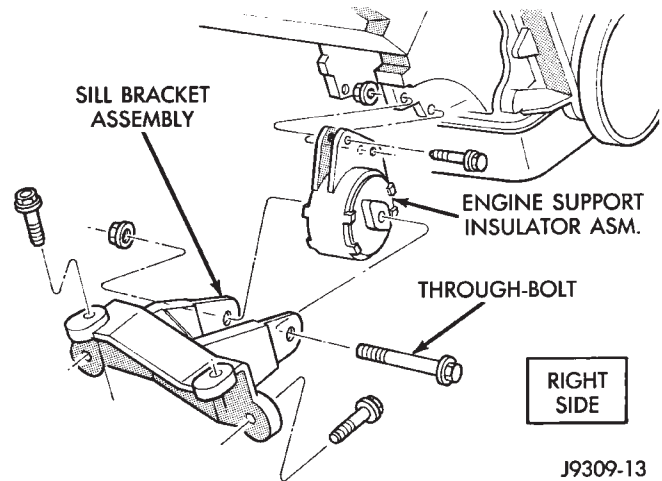


Fig. 14 Front Engine Mount—Right Side

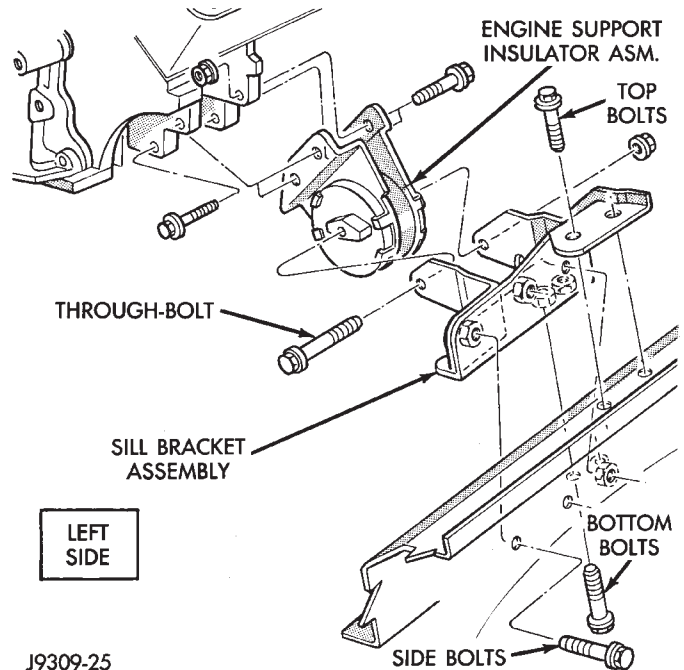


Fig. 15 Front Engine Mount—Left Side

- (7) If required, remove the sill bracket assembly.

INSTALLATION

- (1) If the sill bracket assembly was removed, install the bracket to the sill assembly.

REMOVAL AND INSTALLATION (Continued)

(a) **RIGHT SIDE**—Install the sill bracket assembly onto the sill assembly (Fig. 14). Install and tighten the bolts to 65 N·m (48 ft. lbs.) torque.

(b) **LEFT SIDE**—Install the sill bracket assembly onto the sill assembly (Fig. 15). Install and tighten the 2 top bolts to 65 N·m (48 ft. lbs.) torque. Install and tighten the 2 side bolts to 95 N·m (70 ft. lbs.) torque. Install and tighten the 2 bottom bolts to 121 N·m (89 ft. lbs.) torque.

(2) With the engine raised **SLIGHTLY**, position engine support insulator assembly onto the engine block (Fig. 14) (Fig. 15). Install bolts and tighten to 88 N·m (65 ft. lbs.) torque.

(3) Lower engine with lifting fixture while aligning engine support insulator assembly into sill bracket assembly.

(4) Install the thru-bolt and nut. Tighten the **RIGHT SIDE** nut to 81 N·m (60 ft. lbs.) torque. Tighten the **LEFT SIDE** nut to 81 N·m (60 ft. lbs.) torque.

(5) Lower the vehicle.

(6) Remove lifting fixture.

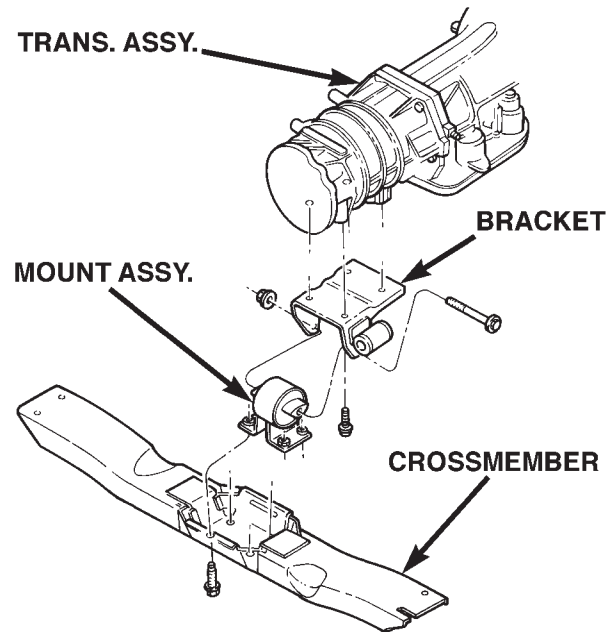
(7) Connect the negative cable to the battery.

ENGINE MOUNT—REAR**REMOVAL**

- (1) Disconnect the negative cable from the battery.
- (2) Raise the vehicle on a hoist.
- (3) Support the transmission with a jack.
- (4) Remove stud nuts attaching engine mount to crossmember (Fig. 16). Remove mount.
- (5) Raise the transmission and engine **SLIGHTLY**.
- (6) Remove engine mount bracket thru-bolt (Fig. 16).
- (7) Remove the engine mount assembly from the adaptor (Fig. 16).
- (8) If required, remove the transmission support bracket adaptor.

INSTALLATION

- (1) Position the rear mount bracket onto the exhaust hanger (if previously removed). Position the rear mount bracket assembly onto the transmission and install the bolts. Tighten the bolts to 46 N·m (34 ft. lbs.).
- (2) Position mount into mount bracket and install thru-bolt and nut. **DO NOT** tighten the bolt at this time.
- (3) Lower the transmission until the mount fastening studs are in position in the crossmember.
- (4) Remove transmission jack.
- (5) Install the mount fastening nuts and tighten the nuts to 54 N·m (40 ft. lbs.) torque.
- (6) Tighten the thru-bolt nut to 65 N·m (48 ft. lbs.) torque.
- (7) Lower the vehicle.



80a7e302

Fig. 16 Rear Engine Mount—V-8

- (8) Connect the negative cable to the battery.

ENGINE ASSEMBLY**REMOVAL**

- (1) Scribe hood hinge outlines on hood and remove the hood.
- (2) Remove the battery.
- (3) Drain cooling system.
- (4) Remove the air cleaner and tube.
- (5) Set fan shroud aside.
- (6) Remove radiator and heater hoses. Remove the radiator (refer to Group 7, Cooling System).
- (7) Remove the vacuum lines.
- (8) Remove the distributor cap and wiring.
- (9) Disconnect the accelerator linkage.
- (10) Perform the Fuel System Pressure Release procedure (refer to Group 14, Fuel System).
- (11) Remove throttle body.
- (12) Remove the starter wires.
- (13) Remove the oil pressure wire.
- (14) Discharge the air conditioning system, if equipped (refer to Group 24, Heating and Air Conditioning for service procedures).
- (15) Remove air conditioning hoses.
- (16) Disconnect the power steering hoses, if equipped.
- (17) Remove starter motor (refer to Group 8B, Battery/Starter Service).
- (18) Remove the generator (refer to Group 8C, Generator Service).
- (19) Raise and support the vehicle on a hoist.
- (20) Disconnect exhaust pipe at manifold.

REMOVAL AND INSTALLATION (Continued)

(21) Support automatic transmission with a transmission stand. This will assure that the torque converter will remain in proper position in the transmission housing.

(22) Remove bell housing bolts and inspection plate. Attach C-clamp on front bottom of transmission torque converter housing to prevent torque converter from coming out.

(23) Remove torque converter drive plate bolts from torque converter drive plate. Mark converter and drive plate to aid in assembly.

(24) Disconnect the engine from the torque converter drive plate.

CAUTION: DO NOT lift the engine by the intake manifold.

- (25) Install an engine lifting fixture.
- (26) Remove the engine front mount thru-bolts.
- (27) Lower the vehicle.
- (28) Remove engine from engine compartment.
- (29) Install on engine repair stand.

INSTALLATION

(1) Remove engine from the repair stand and position in the engine compartment.

- (2) Install engine support fixture.
- (3) Raise and support the vehicle on a hoist.
- (4) Position the torque converter and drive plate.

Install torque converter drive plate bolts. Tighten the bolts to 31 N·m (270 in. lbs.) torque.

- (5) Install the engine front mount thru-bolts.
- (6) Install bell housing bolts. Tighten the bolts to 41 N·m (30 ft. lbs.) torque.
- (7) Remove C-clamp and install inspection plate.
- (8) Remove stand from transmission.
- (9) Install exhaust pipe to manifold.
- (10) Lower the vehicle.
- (11) Remove engine lifting fixture.
- (12) Install the generator (refer to Group 8C, Generator Service).

(13) Install starter motor (refer to Group 8B, Battery/Starter Service).

- (14) Install power steering hoses, if equipped.
- (15) Install air conditioning hoses.
- (16) Charge the air conditioner, if equipped (refer to Group 24, Heater and Air Conditioning for service procedures).

(17) Using a new gasket, install throttle body. Tighten the throttle body bolts to 23 N·m (200 in. lbs.) torque.

- (18) Connect the accelerator linkage.
- (19) Connect the starter wires.
- (20) Connect the oil pressure wire.
- (21) Install the distributor cap and wiring.
- (22) Install vacuum lines.

(23) Install radiator, radiator hoses and heater hoses (refer to Group 7, Cooling System).

(24) Install fan shroud in position.

(25) Install the battery

(26) Fill cooling system (refer to Group 7, Cooling System for the proper procedure).

(27) Install the air cleaner.

(28) Warm engine and adjust.

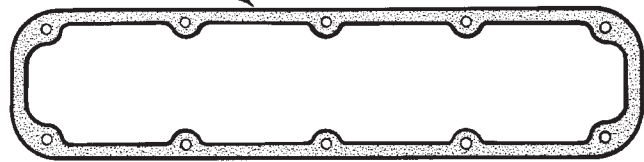
(29) Install hood and line up.

(30) Road test vehicle.

CYLINDER HEAD COVER

A steel backed silicon gasket is used with the cylinder head cover (Fig. 17). This gasket can be used again.

CYLINDER HEAD COVER GASKET



J9209-105

Fig. 17 Cylinder Head Cover Gasket

REMOVAL

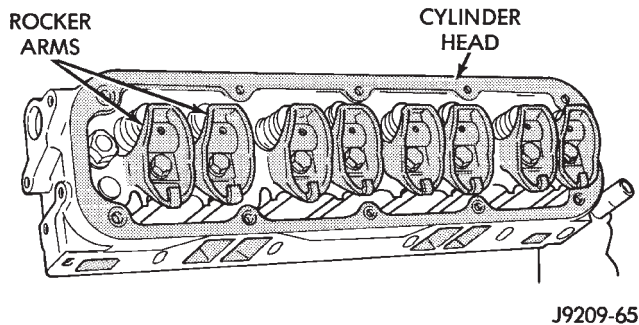
- (1) Disconnect the negative cable from the battery.
- (2) Disconnect closed ventilation system and evaporation control system from cylinder head cover.
- (3) On the left cover, remove the coolant tube bracket.
- (4) Remove the ignition wires from the holders.
- (5) Remove cylinder head cover and gasket. The gasket may be used again.
- (6) Clean cylinder head cover gasket surface.
- (7) Clean head rail, if necessary.

INSTALLATION

- (1) Inspect cover for distortion and straighten, if necessary.
- (2) Check the gasket for use in head cover installation. If damaged, use a new gasket.
- (3) The cylinder head cover gasket can be used again. Install the gasket onto the head rail.
- (4) Position the cylinder head cover onto the gasket. On the left cover, install the coolant tube bracket (refer to Group 7, Cooling System). Tighten the bolts to 11 N·m (95 in. lbs.) torque.
- (5) Install the ignition wires onto the holders.
- (6) Install closed crankcase ventilation system and evaporation control system.
- (7) Connect the negative cable to the battery.

REMOVAL AND INSTALLATION (Continued)**ROCKER ARMS AND PUSH RODS****REMOVAL**

- (1) Disconnect spark plug wires by pulling on the boot straight out in line with plug.
- (2) Remove cylinder head cover and gasket.
- (3) Remove the rocker arm bolts and pivots (Fig. 18). Place them on a bench in the same order as removed.
- (4) Remove the push rods and place them on a bench in the same order as removed.

**Fig. 18 Rocker Arms****INSTALLATION**

- (1) Rotate the crankshaft until the "V8" mark lines up with the TDC mark on the timing chain case cover. This mark is located 147° ATDC from the No.1 firing position.
- (2) Install the push rods in the same order as removed.
- (3) Install rocker arm and pivot assemblies in the same order as removed. Tighten the rocker arm bolts to 28 N·m (21 ft. lbs.) torque.

CAUTION: DO NOT rotate or crank the engine during or immediately after rocker arm installation. Allow the hydraulic roller tappets adequate time to bleed down (about 5 minutes).

- (4) Install cylinder head cover.
- (5) Connect spark plug wires.

VALVE SPRING AND STEM SEAL REPLACEMENT- IN VEHICLE

- (1) Set engine basic timing to Top Dead Center (TDC).
- (2) Remove the air cleaner.
- (3) Remove cylinder head covers and spark plugs.
- (4) Remove coil wire from distributor and secure to good ground to prevent engine from starting.
- (5) Using suitable socket and flex handle at crankshaft retaining bolt, turn engine so the No.1 piston is at TDC on the compression stroke.
- (6) Remove rocker arms.

(7) With air hose attached to an adapter installed in No.1 spark plug hole, apply 620-689 kPa (90-100 psi) air pressure.

(8) Using Valve Spring Compressor Tool MD-998772A with adaptor 6716A, compress valve spring and remove retainer valve locks and valve spring.

(9) Install seals on the exhaust valve stem and position down against valve guides.

(10) The intake valve stem seals should be pushed firmly and squarely over the valve guide using the valve stem as a guide. **DO NOT** force seal against top of guide. When installing the valve retainer locks, compress the spring only enough to install the locks.

(11) Follow the same procedure on the remaining 7 cylinders using the firing sequence 1-8-4-3-6-5-7-2. Make sure piston in cylinder is at TDC on the valve spring that is being removed.

(12) Remove adapter from the No.1 spark plug hole.

- (13) Install rocker arms.
- (14) Install covers and coil wire to distributor.
- (15) Install air cleaner.
- (16) Road test vehicle.

CYLINDER HEAD**REMOVAL**

- (1) Disconnect the battery negative cable.
- (2) Drain cooling system (refer to Group 7, Cooling System for the proper procedures).
- (3) Remove the generator.
- (4) Remove closed crankcase ventilation system.
- (5) Disconnect the evaporation control system.
- (6) Remove the air cleaner.
- (7) Perform the Fuel System Pressure Release procedure (refer to Group 14, Fuel System). Disconnect the fuel supply line.
- (8) Disconnect accelerator linkage and if so equipped, the speed control and transmission kick-down cables.
- (9) Remove distributor cap and wires.
- (10) Disconnect the coil wires.
- (11) Disconnect heat indicator sending unit wire.
- (12) Disconnect heater hoses and bypass hose.
- (13) Remove cylinder head covers and gaskets.
- (14) Remove intake manifold and throttle body as an assembly. Discard the flange side gaskets and the front and rear cross-over gaskets.
- (15) Remove exhaust manifolds.
- (16) Remove rocker arm assemblies and push rods. Identify to ensure installation in original locations.
- (17) Remove the head bolts from each cylinder head and remove cylinder heads. Discard the cylinder head gasket.
- (18) Remove spark plugs.

REMOVAL AND INSTALLATION (Continued)

INSTALLATION

(1) Position the new cylinder head gaskets onto the cylinder block.

(2) Position the cylinder heads onto head gaskets and cylinder block.

(3) Starting at top center, tighten all cylinder head bolts, in sequence, to 68 N·m (50 ft. lbs.) torque (Fig. 19). Repeat procedure, tighten all cylinder head bolts to 143 N·m (105 ft. lbs.) torque. Repeat procedure to confirm that all bolts are at 143 N·m (105 ft. lbs.) torque.

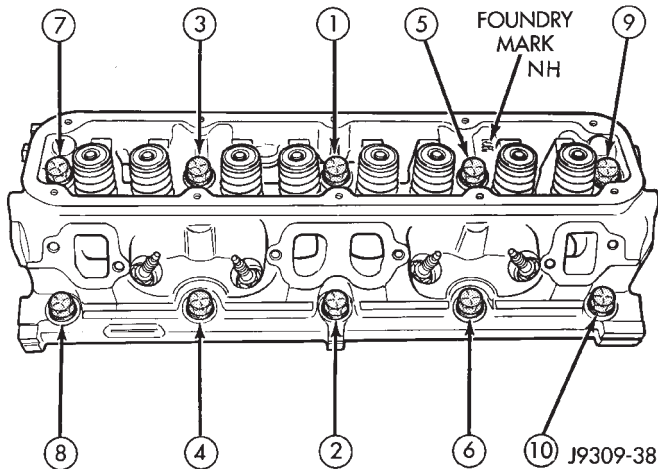


Fig. 19 Cylinder Head Bolt Tightening Sequence

CAUTION: When tightening the rocker arm bolts, make sure the piston in that cylinder is NOT at TDC. Contact between the valves and piston could occur.

(4) Install push rods and rocker arm assemblies in their original position. Tighten the bolts to 28 N·m (21 ft. lbs.) torque.

(5) Install the intake manifold and throttle body assembly (refer to Group 11, Exhaust System and Intake Manifold).

(6) Install exhaust manifolds. Tighten the bolts and nuts to 34 N·m (25 ft. lbs.) torque.

(7) Adjust spark plugs to specifications (refer to Group 8D, Ignition System). Install the plugs and tighten to 41 N·m (30 ft. lbs.) torque.

(8) Install coil wires.

(9) Connect heat indicator sending unit wire.

(10) Connect the heater hoses and bypass hose.

(11) Install distributor cap and wires.

(12) Connect the accelerator linkage and if so equipped, the speed control and transmission kick-down cables.

(13) Install the fuel supply line.

(14) Install the generator and drive belt. Tighten generator mounting bolt to 41 N·m (30 ft. lbs.) torque. Tighten the adjusting strap bolt to 23 N·m

(200 in. lbs.) torque. Refer to Group 7, Cooling System for adjusting the belt tension.

(15) Install the intake manifold-to-generator bracket support rod. Tighten the bolts.

(16) Place the cylinder head cover gaskets in position and install cylinder head covers. Tighten the bolts to 11 N·m (95 in. lbs.) torque.

(17) Install closed crankcase ventilation system.

(18) Connect the evaporation control system.

(19) Install the air cleaner.

(20) Fill cooling system (refer to Group 7, Cooling System for proper procedure).

(21) Connect the negative cable to the battery.

VALVES AND VALVE SPRINGS

REMOVAL

(1) Remove the cylinder head.

(2) Compress valve springs using Valve Spring Compressor Tool MD- 998772A and adapter 6716A.

(3) Remove valve retaining locks, valve spring retainers, valve stem seals and valve springs.

(4) Before removing valves, remove any burrs from valve stem lock grooves to prevent damage to the valve guides. Identify valves to ensure installation in original location.

INSTALLATION

(1) Clean valves thoroughly. Discard burned, warped and cracked valves.

(2) Remove carbon and varnish deposits from inside of valve guides with a reliable guide cleaner.

(3) Measure valve stems for wear. If wear exceeds 0.051 mm (0.002 inch), replace the valve.

(4) Coat valve stems with lubrication oil and insert them in cylinder head.

(5) If valves or seats are reground, check valve stem height. If valve is too long, replace cylinder head.

(6) Install new seals on all valve guides. Install valve springs and valve retainers.

(7) Compress valve springs with Valve Spring Compressor Tool MD-998772A and adapter 6716A, install locks and release tool. If valves and/or seats are ground, measure the installed height of springs. Make sure the measurement is taken from bottom of spring seat in cylinder head to the bottom surface of spring retainer. If spacers are installed, measure from the top of spacer. If height is greater than 42.86 mm (1-11/16 inches), install a 1.587 mm (1/16 inch) spacer in head counterbore. This should bring spring height back to normal 41.27 to 42.86 mm (1-5/8 to 1-11/16 inch).

REMOVAL AND INSTALLATION (Continued)**HYDRAULIC TAPPETS****REMOVAL**

- (1) Remove the air cleaner.
- (2) Remove cylinder head cover, rocker assembly and push rods. Identify push rods to ensure installation in original location.
- (3) Remove intake manifold, yoke retainer and aligning yokes.
- (4) Slide Hydraulic Tappet Remover/Installer Tool C-4129-A through opening in cylinder head and seat tool firmly in the head of tappet.
- (5) Pull tappet out of bore with a twisting motion. If all tappets are to be removed, identify tappets to ensure installation in original location.

INSTALLATION

- (1) If the tappet or bore in cylinder block is scored, scuffed, or shows signs of sticking, ream the bore to next oversize. Replace with oversize tappet.
- (2) Lubricate tappets.
- (3) Install tappets and push rods in their original positions. Ensure that the oil feed hole in the side of the tappet body faces up (away from the crankshaft).
- (4) Install aligning yokes with ARROW toward camshaft.
- (5) Install yoke retainer. Tighten the bolts to 23 N·m (200 in. lbs.) torque. Install intake manifold.
- (6) Install push rods in original positions.
- (7) Install rocker arm.
- (8) Install cylinder head cover.
- (9) Start and operate engine. Warm up to normal operating temperature.

CAUTION: To prevent damage to valve mechanism, engine must not be run above fast idle until all hydraulic tappets have filled with oil and have become quiet.

VIBRATION DAMPER**REMOVAL**

- (1) Disconnect the negative cable from the battery.
- (2) Remove fan shroud retainer bolts and set shroud back over engine.
- (3) Remove the cooling system fan.
- (4) Remove the serpentine belt (refer to Group 7, Cooling System).
- (5) Remove the vibration damper pulley.
- (6) Remove vibration damper bolt and washer from end of crankshaft.
- (7) Install bar and screw from Puller Tool Set C-3688. Install 2 bolts with washers through the puller tool and into the vibration damper (Fig. 20).
- (8) Pull vibration damper off of the crankshaft.

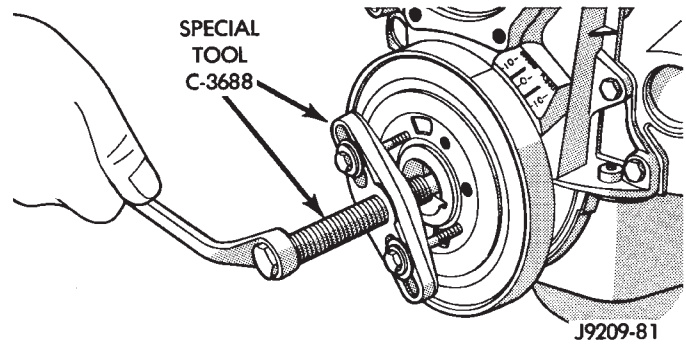


Fig. 20 Vibration Damper Assembly

INSTALLATION

- (1) Position the vibration damper onto the crankshaft.
- (2) Place installing tool, part of Puller Tool Set C-3688 in position and press the vibration damper onto the crankshaft (Fig. 21).

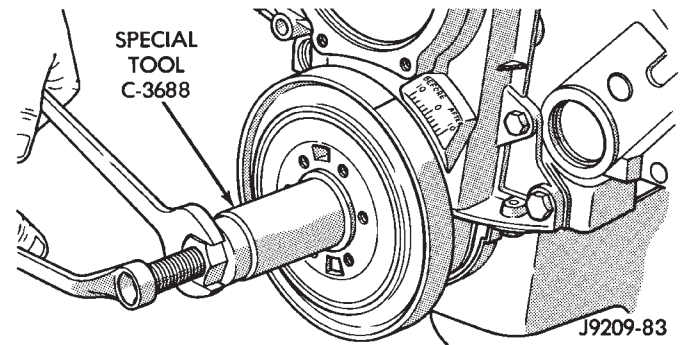


Fig. 21 Installing Vibration Damper

- (3) Install the crankshaft bolt and washer. Tighten the bolt to 183 N·m (135 ft. lbs.) torque.
- (4) Install the crankshaft pulley. Tighten the pulley bolts to 23 N·m (200 in. lbs.) torque.
- (5) Install the serpentine belt (refer to Group 7, Cooling System).
- (6) Install the cooling system fan. Tighten the bolts to 23 N·m (17 ft. lbs.) torque.
- (7) Position the fan shroud and install the bolts. Tighten the retainer bolts to 11 N·m (95 in. lbs.) torque.
- (8) Connect the negative cable to the battery.

TIMING CHAIN COVER**REMOVAL**

- (1) Disconnect the negative cable from the battery.
- (2) Drain cooling system (refer to Group 7, Cooling System).
- (3) Remove the serpentine belt (refer to Group 7, Cooling System).
- (4) Remove water pump (refer to Group 7, Cooling System).

REMOVAL AND INSTALLATION (Continued)

- (5) Remove power steering pump (refer to Group 19, Steering).
- (6) Remove vibration damper.
- (7) Loosen oil pan bolts and remove the front bolt at each side.
- (8) Remove the cover bolts.
- (9) Remove chain case cover and gasket using extreme caution to avoid damaging oil pan gasket.
- (10) Place a suitable tool behind the lips of the oil seal to pry the oil seal outward. Be careful not to damage the crankshaft seal surface of cover (Fig. 22).

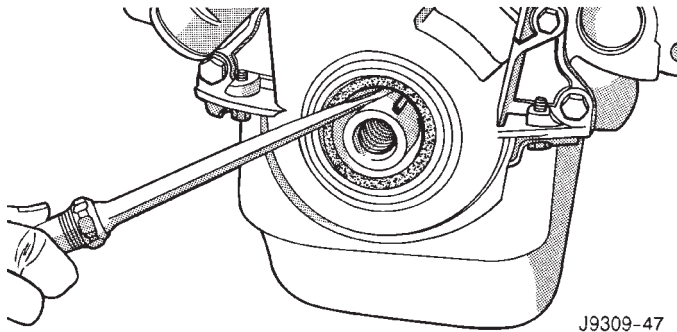


Fig. 22 Removal of Front Crankshaft Oil Seal

INSTALLATION

- (1) Using a new cover gasket, carefully install chain case cover to avoid damaging oil pan gasket. Use a small amount of Mopar® Silicone Rubber Adhesive Sealant, or equivalent, at the joint between timing chain cover gasket and the oil pan gasket. Finger tighten the timing chain cover bolts at this time.
- (2) Place the smaller diameter of the oil seal over Front Oil Seal Installation Tool 6635 (Fig. 23). Seat the oil seal in the groove of the tool.

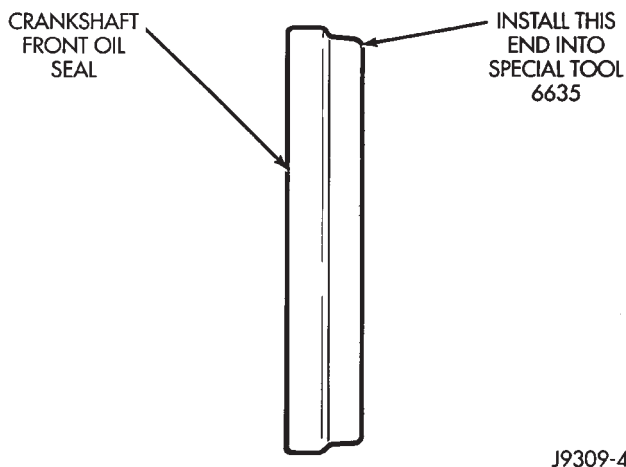


Fig. 23 Placing Oil Seal on Installation Tool 6635

- (3) Position the seal and tool onto the crankshaft (Fig. 24).
- (4) Tighten the 4 lower chain case cover bolts to 13N-m (10 ft.lbs.) to prevent the cover from tipping during seal installation.

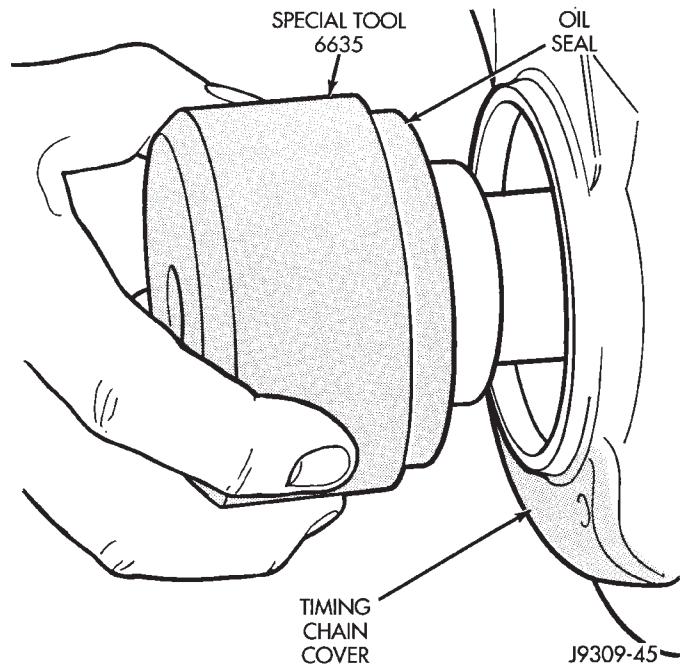


Fig. 24 Position Tool and Seal onto Crankshaft

- (5) Using the vibration damper bolt, tighten the bolt to draw the seal into position on the crankshaft (Fig. 25).

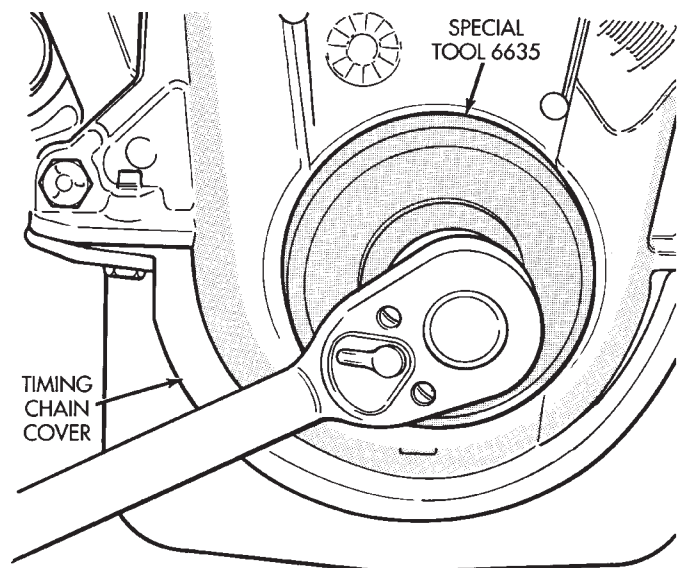


Fig. 25 Installing Oil Seal

- (6) Loosen the 4 bolts tightened in step 4 to allow realignment of front cover assembly.
- (7) Tighten chain case cover bolts to 41 N-m (30 ft. lbs.) torque. Tighten oil pan bolts to 24 N-m (215 in. lbs.) torque.
- (8) Remove the vibration damper bolt and seal installation tool.

REMOVAL AND INSTALLATION (Continued)

- (9) Install vibration damper.
- (10) Install water pump and housing assembly using new gaskets (refer to Group 7, Cooling System). Tighten bolts to 41 N·m (30 ft. lbs.) torque.
- (11) Install power steering pump (refer to Group 19, Steering).
- (12) Install the serpentine belt (refer to Group 7, Cooling System).
- (13) Install the cooling system fan. Tighten the bolts to 23 N·m (17 ft. lbs.) torque.
- (14) Position the fan shroud and install the bolts. Tighten the bolts to 11 N·m (95 in. lbs.) torque.
- (15) Fill cooling system (refer to Group 7, Cooling System for the proper procedure).
- (16) Connect the negative cable to the battery.

TIMING CHAIN

REMOVAL

- (1) Remove Timing Chain Cover Refer to procedure in this section.
- (2) Remove camshaft sprocket attaching bolt and remove timing chain with crankshaft and camshaft sprockets.

INSTALLATION

- (1) Place both camshaft sprocket and crankshaft sprocket on the bench with timing marks on exact imaginary center line through both camshaft and crankshaft bores.
- (2) Place timing chain around both sprockets.
- (3) Turn crankshaft and camshaft to line up with keyway location in crankshaft sprocket and in camshaft sprocket.
- (4) Lift sprockets and chain (keep sprockets tight against the chain in position as described).
- (5) Slide both sprockets evenly over their respective shafts and use a straightedge to check alignment of timing marks (Fig. 26).

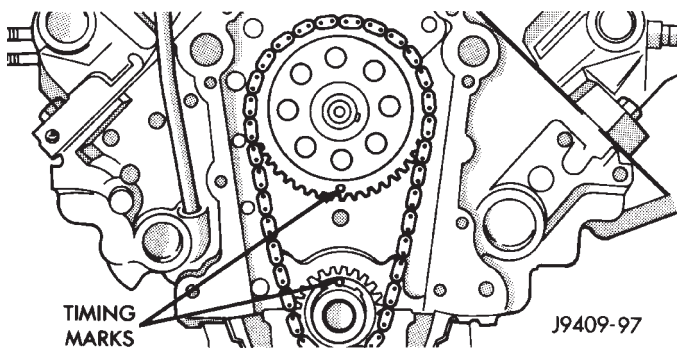


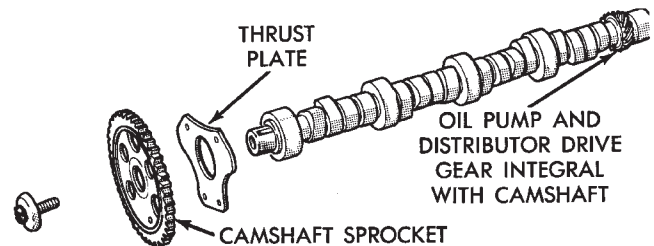
Fig. 26 Alignment of Timing Marks

- (6) Install the camshaft bolt. Tighten the bolt to 68 N·m (50 ft. lbs.) torque.
- (7) Check camshaft end play. The end play should be 0.051-0.152 mm (0.002-0.006 inch) with a new

thrust plate and up to 0.254 mm (0.010 inch) with a used thrust plate. If not within these limits install a new thrust plate.

CAMSHAFT

NOTE: The camshaft has an integral oil pump and distributor drive gear (Fig. 27).

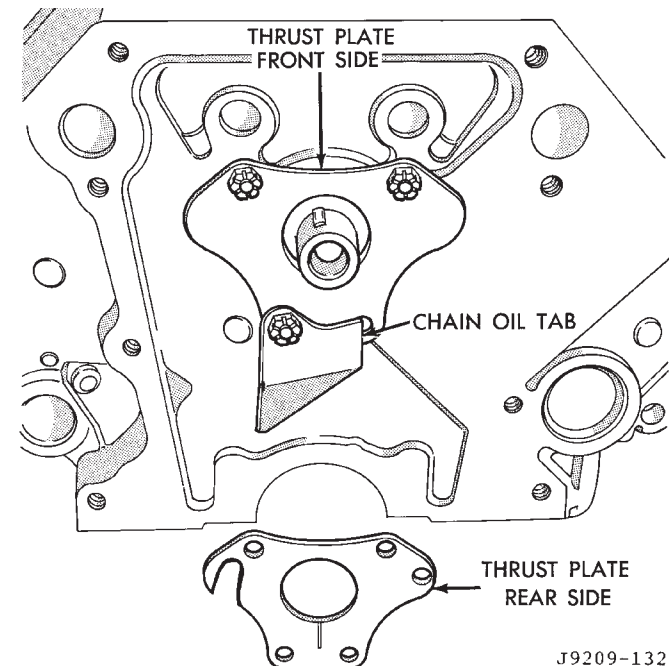


J9309-71

Fig. 27 Camshaft and Sprocket Assembly

REMOVAL

- (1) Remove intake manifold.
- (2) Remove cylinder head covers.
- (3) Remove timing case cover and timing chain.
- (4) Remove rocker arms.
- (5) Remove push rods and tappets. Identify each part so it can be installed in its original location.
- (6) Remove distributor and lift out the oil pump and distributor drive shaft.
- (7) Remove camshaft thrust plate, note location of oil tab (Fig. 28).



J9209-132

Fig. 28 Timing Chain Oil Tab Installation

- (8) Install a long bolt into front of camshaft to facilitate removal of the camshaft. Remove camshaft,

REMOVAL AND INSTALLATION (Continued)

being careful not to damage cam bearings with the cam lobes.

INSTALLATION

(1) Lubricate camshaft lobes and camshaft bearing journals and insert the camshaft to within 51 mm (2 inches) of its final position in cylinder block.

NOTE: Whenever an engine has been rebuilt, a new camshaft and/or new tappets installed, add 1 pint of Mopar Crankcase Conditioner, or equivalent. The oil mixture should be left in engine for a minimum of 805 km (500 miles). Drain at the next normal oil change.

(2) Install Camshaft Gear Installer Tool C-3509 with tongue back of distributor drive gear (Fig. 29).

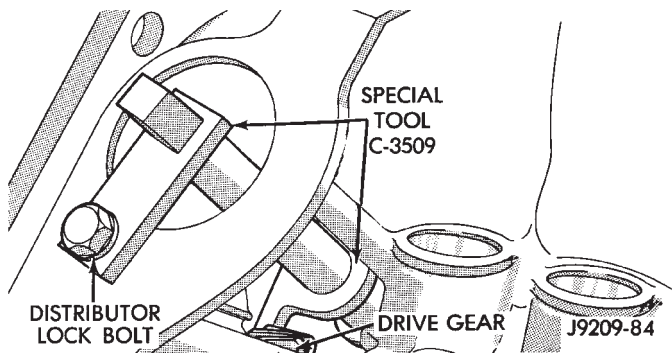


Fig. 29 Camshaft Holding Tool C-3509 (Installed Position)

(3) Hold tool in position with a distributor lock-plate bolt. This tool will restrict camshaft from being pushed in too far and prevent knocking out the welch plug in rear of cylinder block. **Tool should remain installed until the camshaft and crankshaft sprockets and timing chain have been installed.**

(4) Install camshaft thrust plate and chain oil tab. **Make sure tang enters lower right hole in thrust plate.** Tighten bolts to 24 N·m (210 in. lbs.) torque. Top edge of tab should be flat against thrust plate in order to catch oil for chain lubrication.

(5) Place both camshaft sprocket and crankshaft sprocket on the bench with timing marks on exact imaginary center line through both camshaft and crankshaft bores.

(6) Place timing chain around both sprockets.

(7) Turn crankshaft and camshaft to line up with keyway location in crankshaft sprocket and in camshaft sprocket.

(8) Lift sprockets and chain (keep sprockets tight against the chain in position as described).

(9) Slide both sprockets evenly over their respective shafts and use a straightedge to check alignment of timing marks (Fig. 30).

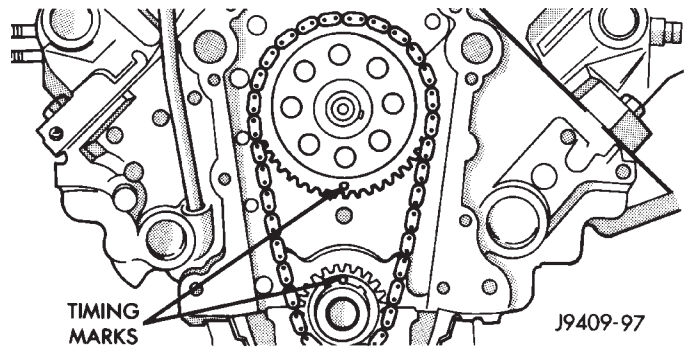


Fig. 30 Alignment of Timing Marks

(10) Install the camshaft bolt/cup washer. Tighten bolt to 68 N·m (50 ft. lbs.) torque.

(11) Measure camshaft end play. Refer to Specifications for proper clearance. If not within limits install a new thrust plate.

(12) Each tappet reused must be installed in the same position from which it was removed. **When camshaft is replaced, all of the tappets must be replaced.**

CAMSHAFT BEARINGS

REMOVAL

NOTE: This procedure requires that the engine is removed from the vehicle.

(1) With engine completely disassembled, drive out rear cam bearing core hole plug.

(2) Install proper size adapters and horseshoe washers (part of Camshaft Bearing Remover/Installer Tool C-3132-A) at back of each bearing shell. Drive out bearing shells (Fig. 31).

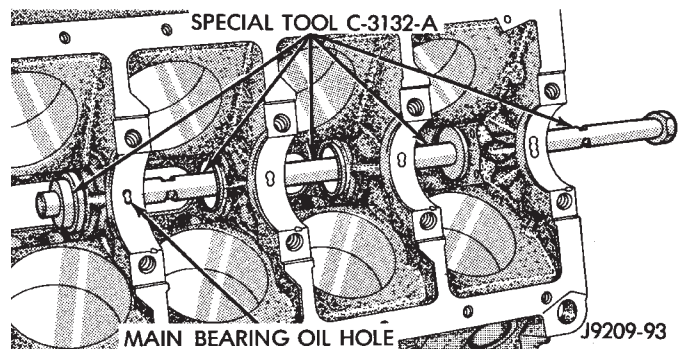


Fig. 31 Camshaft Bearings Removal/Installation with Tool C-3132-A

INSTALLATION

(1) Install new camshaft bearings with Camshaft Bearing Remover/Installer Tool C-3132-A by sliding the new camshaft bearing shell over proper adapter.

REMOVAL AND INSTALLATION (Continued)

(2) Position rear bearing in the tool. Install horse-shoe lock and by reversing removal procedure, carefully drive bearing shell into place.

(3) Install remaining bearings in the same manner. Bearings must be carefully aligned to bring oil holes into full register with oil passages from the main bearing. If the camshaft bearing shell oil holes are not in exact alignment, remove and install them correctly. Install a new core hole plug at the rear of camshaft. **Be sure this plug does not leak.**

CRANKSHAFT MAIN BEARINGS

REMOVAL

- (1) Remove the oil pan.
- (2) Remove the oil pump from the rear main bearing cap.
- (3) Identify bearing caps before removal. Remove bearing caps one at a time.
- (4) Remove upper half of bearing by inserting Crankshaft Main Bearing Remover/Installer Tool C-3059 into the oil hole of crankshaft (Fig. 32).
- (5) Slowly rotate crankshaft clockwise, forcing out upper half of bearing shell.

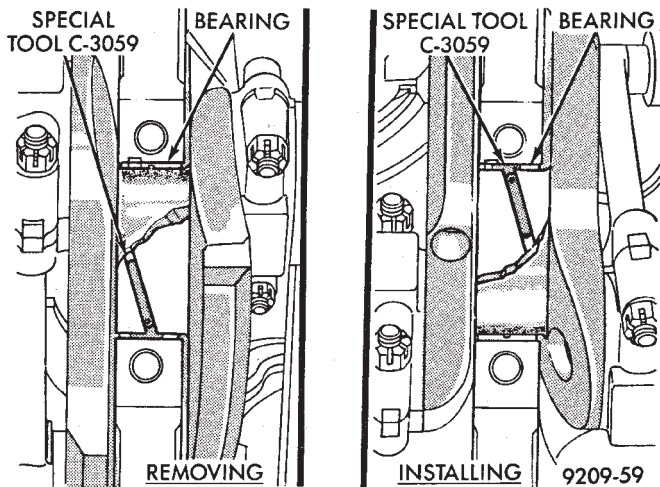


Fig. 32 Upper Main Bearing Removal and Installation with Tool C-3059

INSTALLATION

Only one main bearing should be selectively fitted while all other main bearing caps are properly tightened. All bearing capbolts removed during service procedures are to be cleaned and oiled before installation.

When installing a new upper bearing shell, slightly chamfer the sharp edges from the plain side.

(1) Start bearing in place, and insert Crankshaft Main Bearing Remover/Installer Tool C-3059 into oil hole of crankshaft (Fig. 32).

(2) Slowly rotate crankshaft counterclockwise sliding the bearing into position. Remove Tool C-3059.

(3) Install the bearing caps. Clean and oil the bolts. Tighten the capbolts to 115 N·m (85 ft. lbs.) torque.

- (4) Install the oil pump.
- (5) Install the oil pan.

DISTRIBUTOR DRIVE SHAFT BUSHING

REMOVAL

(1) Remove distributor, refer to Group 8D, Ignition Systems for the proper procedure.

(2) Remove the intake manifold (refer to Group 11, Exhaust System and Intake Manifold).

(3) Insert Distributor Drive Shaft Bushing Puller Tool C-3052 into old bushing and thread down until a tight fit is obtained (Fig. 33).

(4) Hold puller screw and tighten puller nut until bushing is removed.

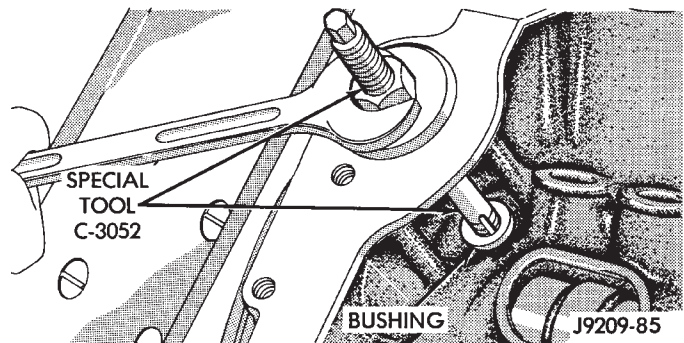


Fig. 33 Distributor Driveshaft Bushing Removal

INSTALLATION

(1) Slide new bushing over burnishing end of Distributor Drive Shaft Bushing Driver/Burnisher Tool C-3053. Insert the tool and bushing into the bore.

(2) Drive bushing and tool into position, using a hammer (Fig. 34).

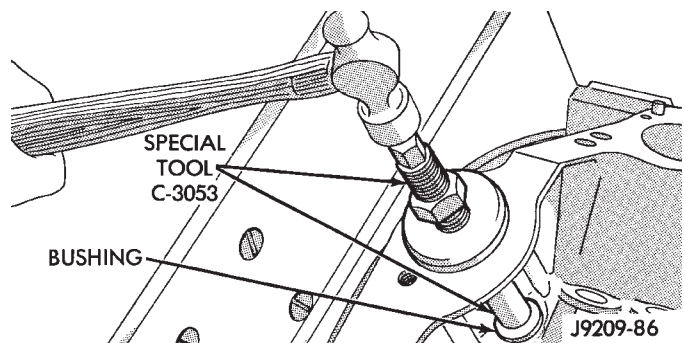


Fig. 34 Distributor Driveshaft Bushing Installation

(3) As the burnisher is pulled through the bushing, the bushing is expanded tight in the block and burnished to correct size (Fig. 35). **DO NOT ream this bushing.**

REMOVAL AND INSTALLATION (Continued)

CAUTION: This procedure **MUST** be followed when installing a new bushing or seizure to shaft may occur.

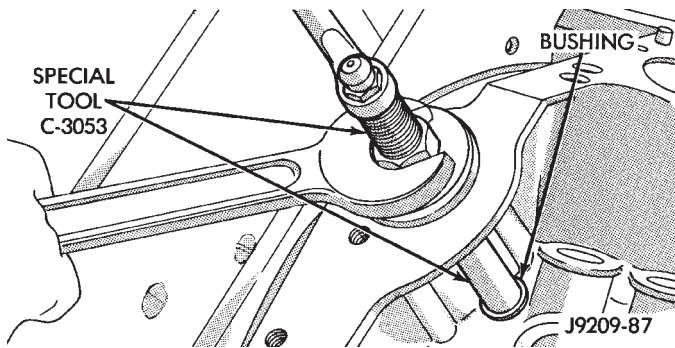


Fig. 35 Burnishing Distributor Driveshaft Bushing

(4) Install the intake manifold (refer to Group 11, Exhaust System and Intake Manifold).

DISTRIBUTOR INSTALLATION

NOTE: Before installing the distributor, the oil pump drive shaft must be aligned to number one cylinder.

(1) Rotate crankshaft until No.1 cylinder is at top dead center on the firing stroke.

(2) When in this position, the timing mark of vibration damper should be under "0" on the timing indicator.

(3) Install the shaft so that after the gear spirals into place, it will index with the oil pump shaft. The slot on top of oil pump shaft should be aligned towards the left front intake manifold attaching bolt hole (Fig. 36).

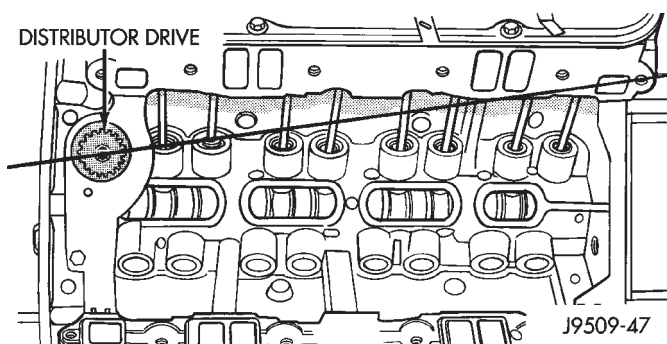


Fig. 36 Position of Oil Pump Shaft Slot

(4) Install distributor, refer to Group 8D, Ignition Systems for the proper procedure.

After the distributor has been installed, its rotational position must be set using the **SET SYNC** mode of the DRB scan tool. Refer to Checking Distributor Position following the Distributor Installation section in Group 8D, Ignition system.

Do not attempt to adjust ignition timing by rotating the distributor. It has no effect on ignition timing. Adjusting distributor position will effect fuel synchronization only.

OIL PAN

REMOVAL

- (1) Disconnect the negative cable from the battery.
- (2) Raise the vehicle.
- (3) Remove the oil pan drain plug and drain the engine oil.
- (4) Remove the oil filter.
- (5) Remove the starter (refer to Group 8B, Battery/Starter/Generator Service).
- (6) If equipped with an oil level sensor, disconnect the sensor.
- (7) Position the cooler lines out of the way.
- (8) Disconnect the oxygen sensor.
- (9) Remove exhaust pipe.
- (10) Remove the oil pan bolts. Carefully slide the oil pan and gasket to the rear. If equipped with an oil level sensor, take care not to damage the sensor.

INSTALLATION

(1) Fabricate 4 alignment dowels from 5/16 x 1 1/2 inch bolts. Cut the head off the bolts and cut a slot into the top of the dowel. This will allow easier installation and removal with a screwdriver (Fig. 37).

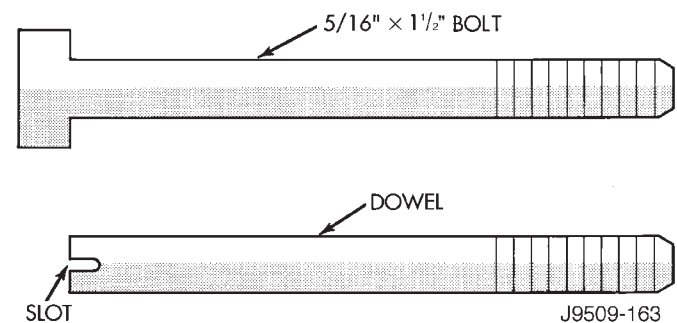


Fig. 37 Fabrication of Alignment Dowels

(2) Install the dowels in the cylinder block (Fig. 38).

(3) Apply small amount of Mopar® Silicone Rubber Adhesive Sealant, or equivalent in the corner of the cap and the cylinder block.

(4) Slide the one-piece gasket over the dowels and onto the block.

(5) Position the oil pan over the dowels and onto the gasket. If equipped with an oil level sensor, take care not to damage the sensor.

(6) Install the oil pan bolts. Tighten the bolts to 24 N·m (215 in. lbs.) torque.

(7) Remove the dowels. Install the remaining oil pan bolts. Tighten these bolts to 24 N·m (215 in. lbs.) torque.

REMOVAL AND INSTALLATION (Continued)

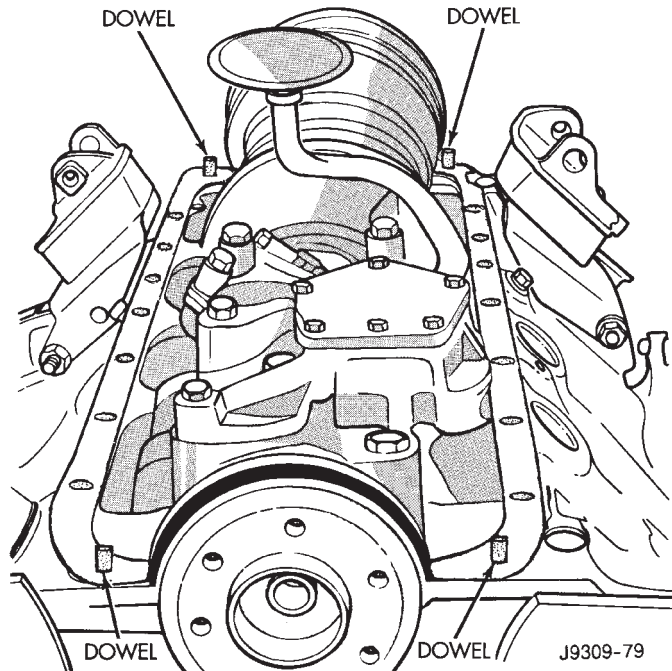


Fig. 38 Position of Dowels in Cylinder Block

- (8) Install the drain plug. Tighten drain plug to 34 N·m (25 ft. lbs.) torque.
- (9) Install exhaust pipe.
- (10) Connect the oxygen sensor.
- (11) Install the oil filter.
- (12) If equipped with an oil level sensor, connect the sensor.
- (13) Install the starter (refer to Group 8B, Battery/Starter/Generator Service).
- (14) Move the cooler lines back into position.
- (15) Lower vehicle.
- (16) Connect the negative cable to the battery.
- (17) Fill the oil pan with engine oil to the specified level.

WARNING: USE EXTREME CAUTION WHEN THE ENGINE IS OPERATING. DO NOT STAND IN A DIRECT LINE WITH THE FAN. DO NOT PUT YOUR HANDS NEAR THE PULLEYS, BELTS OR FAN. DO NOT WEAR LOOSE CLOTHING.

- (18) Start the engine and inspect for leaks.

PISTON AND CONNECTING ROD ASSEMBLY

REMOVAL

- (1) Remove the engine from the vehicle.
- (2) Remove the cylinder head.
- (3) Remove the oil pan.
- (4) Remove top ridge of cylinder bores with a reliable ridge reamer before removing pistons from cylinder block. Be sure to keep tops of pistons covered during this operation.

(5) Be sure the connecting rod and connecting rod cap are identified with the cylinder number. Remove connecting rod cap. Install connecting rod bolt guide set on connecting rod bolts.

(6) Pistons and connecting rods must be removed from top of cylinder block. When removing piston and connecting rod assemblies, rotate crankshaft to center the connecting rod in the cylinder bore and at BDC. **Be careful not to nick crankshaft journals.**

(7) After removal, install bearing cap on the mating rod.

INSTALLATION

(1) Be sure that compression ring gaps are staggered so that neither is in-line with oil ring rail gap.

(2) Before installing the ring compressor, make sure the oil ring expander ends are butted and the rail gaps located properly (Fig. 39).

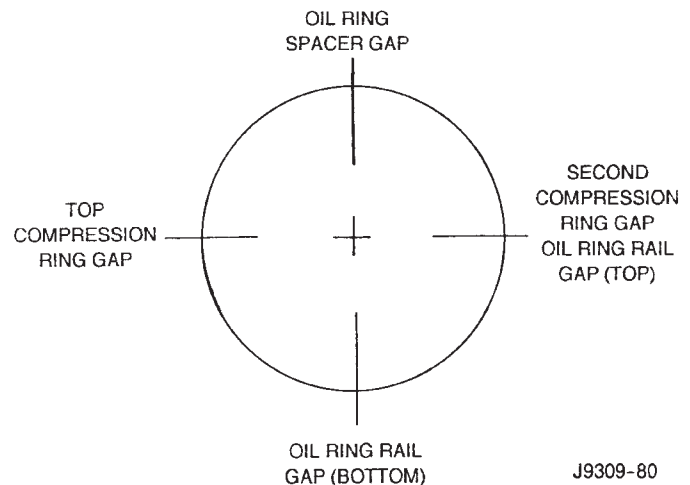


Fig. 39 Proper Ring Installation

(3) Immerse the piston head and rings in clean engine oil. Slide Piston Ring Compressor Tool C-385 over the piston and tighten with the special wrench (part of Tool C-385). **Be sure position of rings does not change during this operation.**

(4) Install connecting rod bolt protectors on rod bolts, the long protector should be installed on the numbered side of the connecting rod.

(5) Rotate crankshaft so that the connecting rod journal is on the center of the cylinder bore. Be sure connecting rod and cylinder bore number are the same. Insert rod and piston into cylinder bore and guide rod over the crankshaft journal.

(6) Tap the piston down in cylinder bore, using a hammer handle. At the same time, guide connecting rod into position on crankshaft journal.

(7) The notch or groove on top of piston must be pointing toward front of engine. The larger chamfer of the connecting rod bore must be installed toward crankshaft journal fillet.

REMOVAL AND INSTALLATION (Continued)

- (8) Install rod caps. Be sure connecting rod, connecting rod cap and cylinder bore number are the same. Install nuts on cleaned and oiled rod bolts and tighten nuts to 61 N·m (45 ft. lbs.) torque.
- (9) Install the oil pan.
- (10) Install the cylinder head.
- (11) Install the engine into the vehicle.

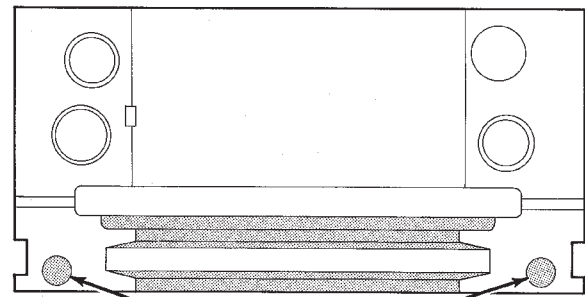
CRANKSHAFT

REMOVAL

- (1) Remove the oil pan.
- (2) Remove the oil pump from the rear main bearing cap.
- (3) Remove the vibration damper.
- (4) Remove the timing chain cover.
- (5) Identify bearing caps before removal. Remove bearing caps and bearings one at a time.
- (6) Lift the crankshaft out of the block.
- (7) Remove and discard the crankshaft rear oil seals.
- (8) Remove and discard the front crankshaft oil seal.

INSTALLATION

- (1) Clean Loctite 518 residue and sealant from the cylinder block and rear cap mating surface. Do this before applying the Loctite drop and the installation of rear cap.
- (2) Lightly oil the new upper seal lips with engine oil.
- (3) Install the new upper rear bearing oil seal with the white paint facing towards the rear of the engine.
- (4) Position the crankshaft into the cylinder block.
- (5) Lightly oil the new lower seal lips with engine oil.
- (6) Install the new lower rear bearing oil seal into the bearing cap with the white paint facing towards the rear of the engine.
- (7) Apply 5 mm (0.20 in) drop of Loctite 518, or equivalent, on each side of the rear main bearing cap (Fig. 40). DO NOT over apply sealant or allow the sealant to contact the rubber seal. Assemble bearing cap to cylinder block immediately after sealant application.
- (8) To align the bearing cap, use cap slot, alignment dowel and cap bolts. DO NOT remove excess material after assembly. DO NOT strike rear cap more than 2 times for proper engagement.
- (9) Clean and oil all cap bolts. Install all main bearing caps. Install all cap bolts and alternately tighten to 115 N·m (85 ft. lbs.) torque.
- (10) Install oil pump.
- (11) Install the timing chain cover.
- (12) Install the vibration damper.
- (13) Apply Mopar® Silicone Rubber Adhesive Sealant, or equivalent, at bearing cap to block joint to



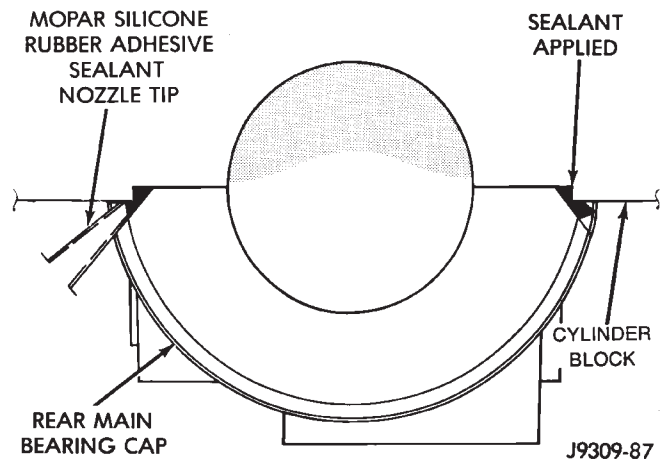
.25 DROP OF LOCTITE 518
ON BOTH SIDES OF
REAR MAIN CAP

J9509-75

Fig. 40 Sealant Application to Bearing Cap

provide cap to block and oil pan sealing (Fig. 41). Apply enough sealant until a small amount is squeezed out. Withdraw nozzle and wipe excess sealant off the oil pan seal groove.

- (14) Install new front crankshaft oil seal.
- (15) Immediately install the oil pan.



J9309-87

Fig. 41 Apply Sealant to Bearing Cap to Block Joint OIL PUMP

REMOVAL

- (1) Remove the oil pan.
- (2) Remove the oil pump from rear main bearing cap.

INSTALLATION

- (1) Install oil pump. During installation slowly rotate pump body to ensure driveshaft-to-pump rotor shaft engagement.
- (2) Hold the oil pump base flush against mating surface on No.5 main bearing cap. Finger tighten pump attaching bolts. Tighten attaching bolts to 41 N·m (30 ft. lbs.) torque.
- (3) Install the oil pan.

REMOVAL AND INSTALLATION (Continued)**CRANKSHAFT OIL SEAL — FRONT**

The oil seal can be replaced without removing the timing chain cover provided the cover is not misaligned.

- (1) Disconnect the negative cable from the battery.
- (2) Remove vibration damper.
- (3) If front seal is suspected of leaking, check front oil seal alignment to crankshaft. The seal installation/alignment tool 6635, should fit with minimum interference. If tool does not fit, the cover must be removed and installed properly.
- (4) Place a suitable tool behind the lips of the oil seal to pry the oil seal outward. Be careful not to damage the crankshaft seal bore of cover.
- (5) Place the smaller diameter of the oil seal over Front Oil Seal Installation Tool 6635 (Fig. 42). Seat the oil seal in the groove of the tool.

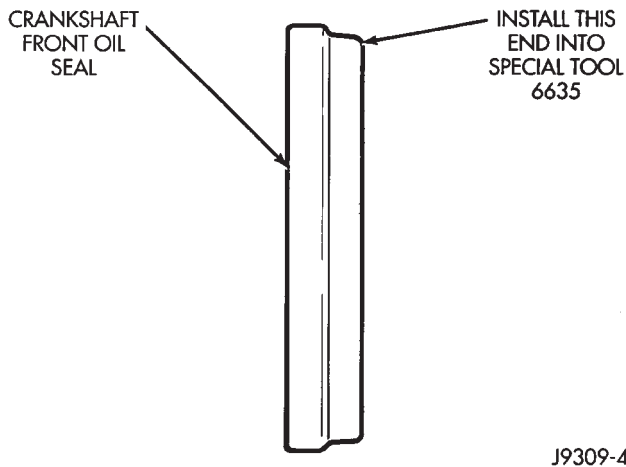


Fig. 42 Placing Oil Seal on Installation Tool 6635

- (6) Position the seal and tool onto the crankshaft (Fig. 43).
- (7) Using the vibration damper bolt, tighten the bolt to draw the seal into position on the crankshaft (Fig. 44).
- (8) Remove the vibration damper bolt and seal installation tool.
- (9) Inspect the seal flange on the vibration damper.
- (10) Install the vibration damper.
- (11) Connect the negative cable to the battery.

CRANKSHAFT OIL SEALS — REAR

The service seal is a 2 piece, viton seal. The upper seal half can be installed with crankshaft removed from engine or with crankshaft installed. When a new upper seal is installed, install a new lower seal. The lower seal half can only be installed with the rear main bearing cap removed.

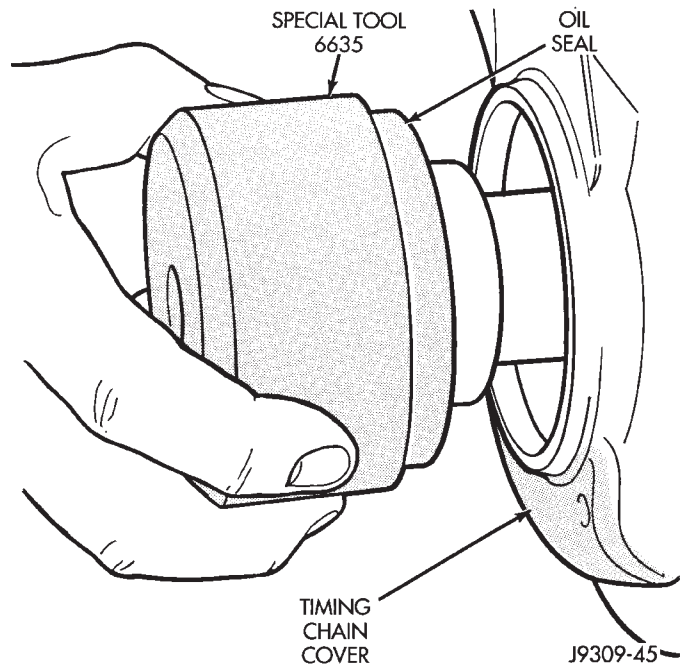


Fig. 43 Position Tool and Seal onto Crankshaft

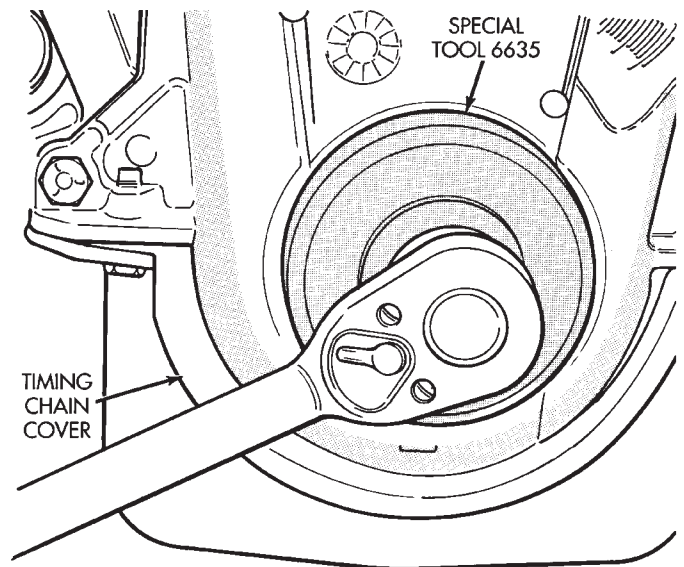


Fig. 44 Installing Oil Seal

UPPER SEAL —CRANKSHAFT REMOVED**REMOVAL**

- (1) Remove the crankshaft. Discard the old upper seal.

INSTALLATION

- (1) Clean the cylinder block rear cap mating surface. Make sure the seal groove is free of debris.

REMOVAL AND INSTALLATION (Continued)

(2) Lightly oil the new upper seal lips with engine oil.

(3) Install the new upper rear bearing oil seal with the white paint facing towards the rear of the engine.

(4) Position the crankshaft into the cylinder block.

(5) Lightly oil the new lower seal lips with engine oil.

(6) Install the new lower rear bearing oil seal into the bearing cap with the white paint facing towards the rear of the engine.

(7) Apply 5 mm (0.20 in) drop of Loctite 518, or equivalent, on each side of the rear main bearing cap (Fig. 45). DO NOT over apply sealant or allow the sealant to contact the rubber seal. Assemble bearing cap to cylinder block immediately after sealant application.

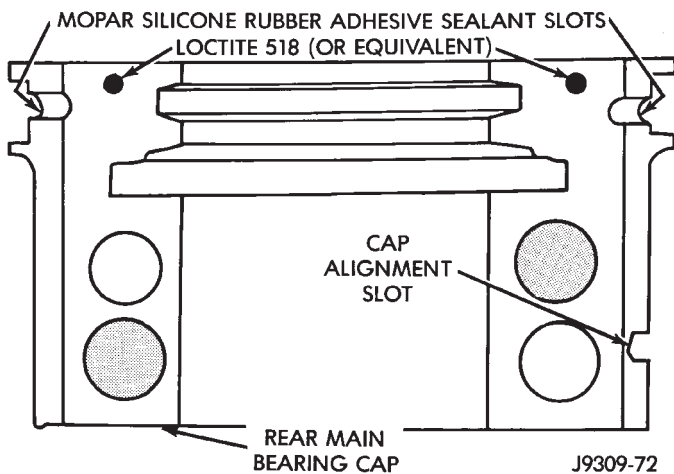


Fig. 45 Sealant Application to Bearing Cap

(8) To align the bearing cap, use cap slot, alignment dowel and cap bolts. DO NOT remove excess material after assembly. DO NOT strike rear cap more than 2 times for proper engagement.

(9) Clean and oil all cap bolts. Install all main bearing caps. Install all cap bolts and alternately tighten to 115 N·m (85 ft. lbs.) torque.

(10) Install oil pump.

(11) Apply Mopar Silicone Rubber Adhesive Sealant, or equivalent, at bearing cap to block joint to provide cap to block and oil pan sealing (Fig. 46). Apply enough sealant until a small amount is squeezed out. Withdraw nozzle and wipe excess sealant off the oil pan seal groove.

(12) Install new front crankshaft oil seal.

(13) Immediately install the oil pan.

UPPER SEAL —CRANKSHAFT INSTALLED

REMOVAL

(1) Remove the oil pan.

(2) Remove the oil pump from the rear main bearing cap.

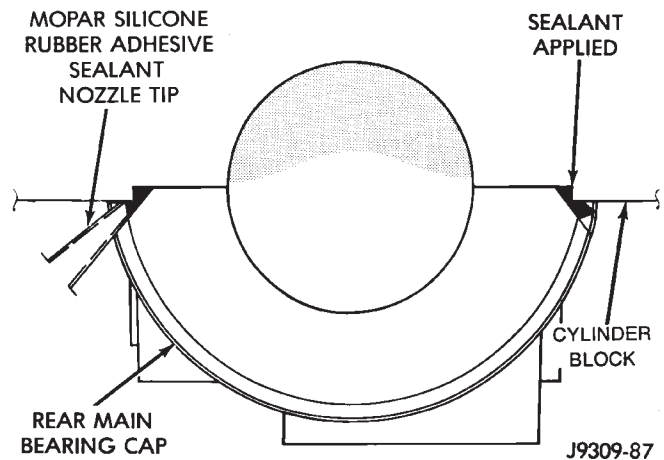


Fig. 46 Apply Sealant to Bearing Cap to Block Joint

(3) Remove the rear main bearing cap. Remove and discard the old lower oil seal.

(4) Carefully remove and discard the old upper oil seal.

INSTALLATION

(1) Clean the cylinder block mating surfaces before oil seal installation. Check for burr at the oil hole on the cylinder block mating surface to rear cap.

(2) Lightly oil the new upper seal lips with engine oil. To allow ease of installation of the seal, loosen at least the 2 main bearing caps forward of the rear bearing cap.

(3) Rotate the new upper seal into the cylinder block being careful not to shave or cut the outer surface of the seal. To assure proper installation, use the installation tool provided with the kit. Install the new seal with the white paint facing towards the rear of the engine.

(4) Install the new lower rear bearing oil seal into the bearing cap with the white paint facing towards the rear of the engine.

(5) Apply 5 mm (0.20 in) drop of Loctite 518, or equivalent, on each side of the rear main bearing cap (Fig. 45). DO NOT over apply sealant or allow the sealant to contact the rubber seal. Assemble bearing cap to cylinder block immediately after sealant application. Be sure the white paint faces toward the rear of the engine.

(6) To align the bearing cap, use cap slot, alignment dowel and cap bolts. DO NOT remove excess material after assembly. DO NOT strike rear cap more than 2 times for proper engagement.

(7) Install the rear main bearing cap with cleaned and oiled cap bolts. Alternately tighten ALL cap bolts to 115 N·m (85 ft. lbs.) torque.

(8) Install oil pump.

(9) Apply Mopar Silicone Rubber Adhesive Sealant, or equivalent, at bearing cap to block joint to provide cap to block and oil pan sealing (Fig. 46). Apply

REMOVAL AND INSTALLATION (Continued)

enough sealant until a small amount is squeezed out. Withdraw nozzle and wipe excess sealant off the oil pan seal groove.

(10) Immediately install the oil pan.

LOWER SEAL

REMOVAL

- (1) Remove the oil pan.
- (2) Remove the oil pump from the rear main bearing cap.
- (3) Remove the rear main bearing cap and discard the old lower seal.

INSTALLATION

- (1) Clean the rear main cap mating surfaces including the oil pan gasket groove.
- (2) Carefully install a new upper seal (refer to Upper Seal Replacement - Crankshaft Installed procedure above).
- (3) Lightly oil the new lower seal lips with engine oil.
- (4) Install a new lower seal in bearing cap with the white paint facing the rear of engine.
- (5) Apply 5 mm (0.20 in) drop of Loctite 518, or equivalent, on each side of the rear main bearing cap (Fig. 45). **DO NOT** over apply sealant or allow the sealant to contact the rubber seal. Assemble bearing cap to cylinder block immediately after sealant application.
- (6) To align the bearing cap, use cap slot, alignment dowel and cap bolts. **DO NOT** remove excess material after assembly. **DO NOT** strike rear cap more than 2 times for proper engagement.
- (7) Install the rear main bearing cap with cleaned and oiled cap bolts. Alternately tighten the cap bolts to 115 N·m (85 ft. lbs.) torque.
- (8) Install oil pump.
- (9) Apply Mopar Silicone Rubber Adhesive Sealant, or equivalent, at bearing cap to block joint to provide cap to block and oil pan sealing (Fig. 46). Apply enough sealant until a small amount is squeezed out. Withdraw nozzle and wipe excess sealant off the oil pan seal groove.
- (10) Immediately install the oil pan.

ENGINE CORE OIL AND CAMSHAFT PLUGS

Engine core plugs have been pressed into the oil galleries behind the camshaft thrust plate (Fig. 47). This will reduce internal leakage and help maintain higher oil pressure at idle.

REMOVAL

- (1) Using a blunt tool such as a drift or a screwdriver and a hammer, strike the bottom edge of the cup plug (Fig. 48).

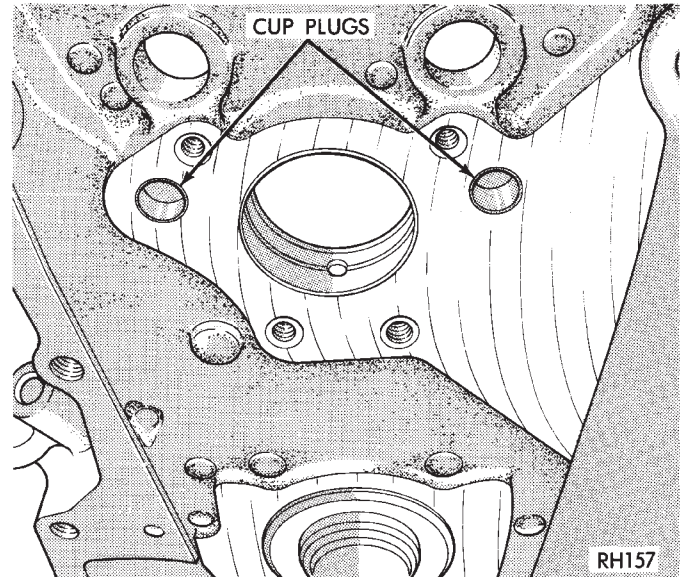


Fig. 47 Location of Cup Plugs in Oil Galleries

- (2) With the cup plug rotated, grasp firmly with pliers or other suitable tool and remove plug (Fig. 48).

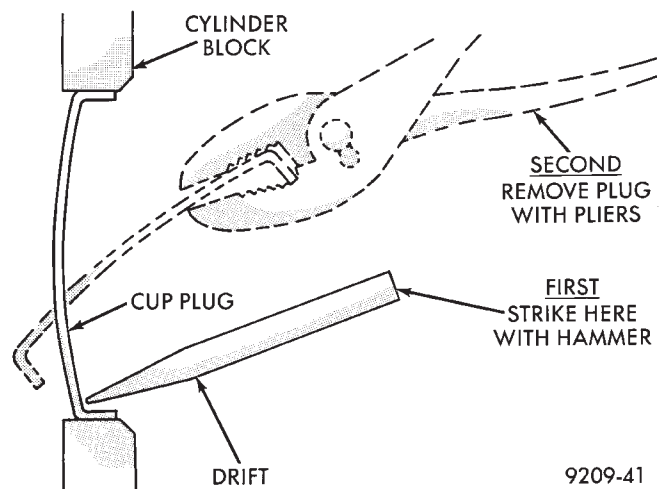


Fig. 48 Core Hole Plug Removal

INSTALLATION

Thoroughly clean inside of cup plug hole in cylinder block or head. Be sure to remove old sealer.

Be certain the new plug is cleaned of all oil or grease.

- (1) Coat edges of plug and core hole with Mopar Gasket Maker, or equivalent.

CAUTION: DO NOT drive cup plug into the casting, as restricted coolant flow can result and cause serious engine problems.

- (2) Using proper plug drive, drive cup plug into hole. The sharp edge of the plug should be at least 0.50 mm (0.020 in.) inside the lead-in chamfer.

REMOVAL AND INSTALLATION (Continued)

(3) It is not necessary to wait for curing of the sealant. The cooling system can be filled and the vehicle placed in service immediately.

DISASSEMBLY AND ASSEMBLY

HYDRAULIC TAPPETS

CAUTION: The plunger and tappet bodies are not interchangeable. The plunger and valve must always be fitted to the original body. It is advisable to work on one tappet at a time to avoid mixing of parts. Mixed parts are not compatible. **DO NOT** disassemble a tappet on a dirty work bench.

DISASSEMBLE

- (1) Pry out plunger retainer spring clip (Fig. 49).
- (2) Clean varnish deposits from inside of tappet body above plunger cap.
- (3) Invert tappet body and remove plunger cap, plunger, check valve, check valve spring, check valve retainer and plunger spring (Fig. 49). Check valve could be flat or ball.

ASSEMBLE

- (1) Clean all tappet parts in a solvent that will remove all varnish and carbon.
- (2) Replace tappets that are unfit for further service with new assemblies.
- (3) If plunger shows signs of scoring or wear, install a new tappet assembly. If valve is pitted, or valve seat on end of plunger is prevented from seating, install a new tappet assembly.
- (4) Assemble tappets (Fig. 49).

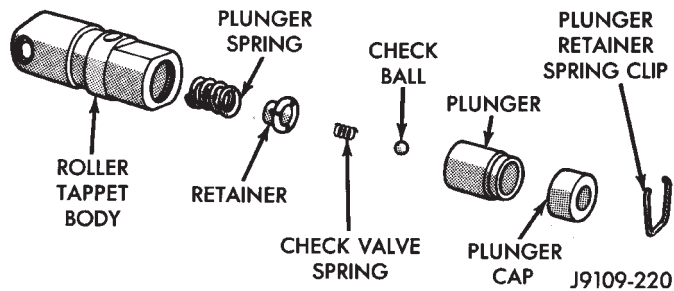


Fig. 49 Hydraulic Tappet Assembly

VALVE SERVICE

VALVE GUIDES

Measure valve stem guide clearance as follows:

- (1) Install Valve Guide Sleeve Tool C-3973 over valve stem and install valve (Fig. 50). The special sleeve places the valve at the correct height for checking with a dial indicator.

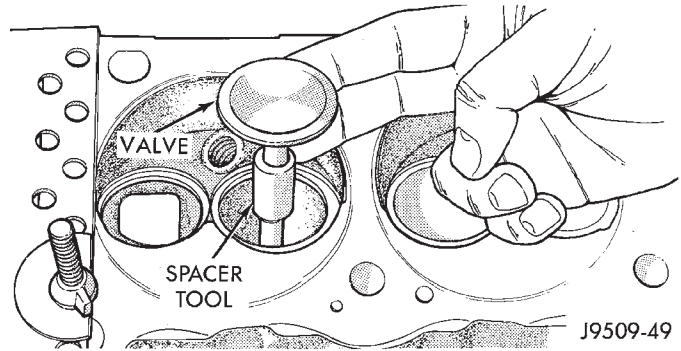


Fig. 50 Positioning Valve with Tool C-3973

- (2) Attach Dial Indicator Tool C-3339 to cylinder head and set it at right angle of valve stem being measured (Fig. 51).

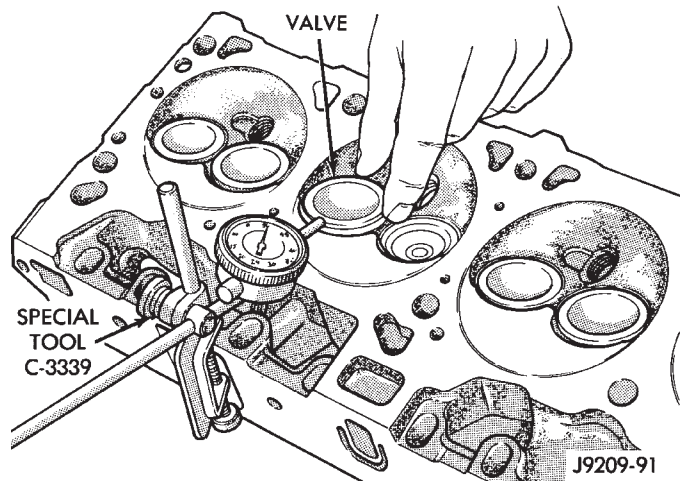


Fig. 51 Measuring Valve Guide Wear

- (3) Move valve to and from the indicator. The total dial indicator reading should not exceed 0.432 mm (0.017 inch). Ream the guides for valves with oversize stems if dial indicator reading is excessive or if the stems are scuffed or scored.

- (4) Service valves with oversize stems are available (Fig. 52).

Reamer O/S	Valve Guide Size
0.076 mm (0.003 in.)	8.026 - 8.052 mm (0.316 - 0.317 in.)
0.381 mm (0.015 in.)	8.331 - 8.357 mm (0.328 - 0.329 in.)

J9309-30

Fig. 52 Reamer Sizes

- (5) Slowly turn reamer by hand and clean guide thoroughly before installing new valve. **Ream the**

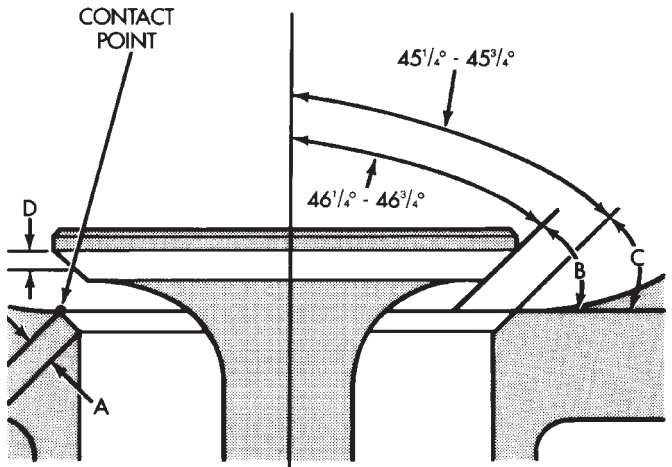
DISASSEMBLY AND ASSEMBLY (Continued)

valve guides from standard to 0.381 mm (0.015 inch). Use a 2 step procedure so the valve guides are reamed true in relation to the valve seat:

- Step 1—Ream to 0.0763 mm (0.003 inch).
- Step 2—Ream to 0.381 mm (0.015 inch).

REFACING VALVES AND VALVE SEATS

The intake and exhaust valves have a $43\frac{1}{4}^\circ$ to $43\frac{3}{4}^\circ$ face angle and a $44\frac{1}{4}^\circ$ to $44\frac{3}{4}^\circ$ seat angle (Fig. 53).



- A - SEAT WIDTH - INTAKE 1.016 - 1.524 mm (0.040 - 0.060 in.)
 EXHAUST 1.524 - 2.032 mm (0.060 - 0.080 in.)
 B - FACE ANGLE (INTAKE & EXHAUST) $43\frac{1}{4}^\circ$ - $43\frac{3}{4}^\circ$
 C - SEAT ANGLE (INTAKE & EXHAUST) $44\frac{1}{4}^\circ$ - $44\frac{3}{4}^\circ$
 D - CONTACT SURFACE

J9309-95

Fig. 53 Valve Face and Seat Angles**VALVES**

Inspect the remaining margin after the valves are refaced (Fig. 54). Valves with less than 1.190 mm (0.047 inch) margin should be discarded.

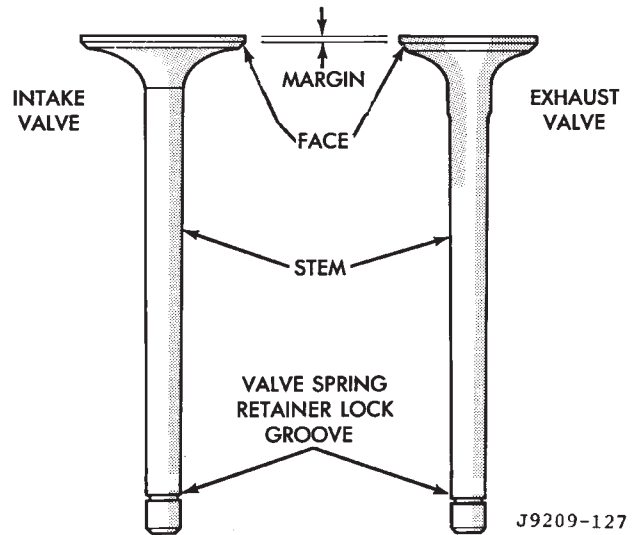
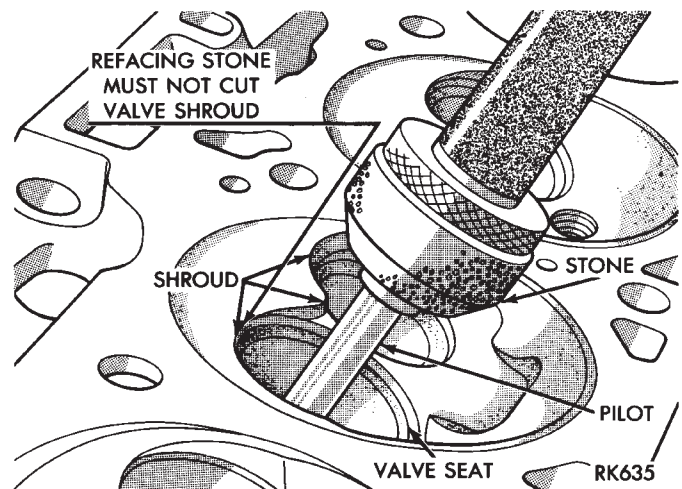
VALVE SEATS

CAUTION: DO NOT un-shroud valves during valve seat refacing (Fig. 55).

(1) When refacing valve seats, it is important that the correct size valve guide pilot be used for reseating stones. A true and complete surface must be obtained.

(2) Measure the concentricity of valve seat using a dial indicator. Total runout should not exceed 0.051 mm (0.002 inch) total indicator reading.

(3) Inspect the valve seat with Prussian blue to determine where the valve contacts the seat. To do this, coat valve seat LIGHTLY with Prussian blue then set valve in place. Rotate the valve with light pressure. If the blue is transferred to the center of

**Fig. 54 Intake and Exhaust Valves****Fig. 55 Refacing Valve Seats**

valve face, contact is satisfactory. If the blue is transferred to the top edge of valve face, lower valve seat with a 15° stone. If the blue is transferred to bottom edge of valve face raise valve seat with a 60° stone.

(4) When seat is properly positioned the width of intake seats should be 1.016-1.524 mm (0.040-0.060 inch). The width of the exhaust seats should be 1.524-2.032 mm (0.060-0.080 inch).

VALVE SPRING INSPECTION

Whenever valves have been removed for inspection, reconditioning or replacement, valve springs should be tested. As an example the compression length of the spring to be tested is $1\frac{5}{16}$ inch. Turn table of Universals Valve Spring Tester Tool until surface is in line with the $1\frac{5}{16}$ inch mark on the threaded stud. Be sure the zero mark is to the front (Fig. 56). Place spring over stud on the table and lift compressing lever to set tone device. Pull on torque wrench until ping is heard. Take reading on torque wrench

DISASSEMBLY AND ASSEMBLY (Continued)

at this instant. Multiply this reading by 2. This will give the spring load at test length. Fractional measurements are indicated on the table for finer adjustments. Refer to specifications to obtain specified height and allowable tensions. Discard the springs that do not meet specifications.

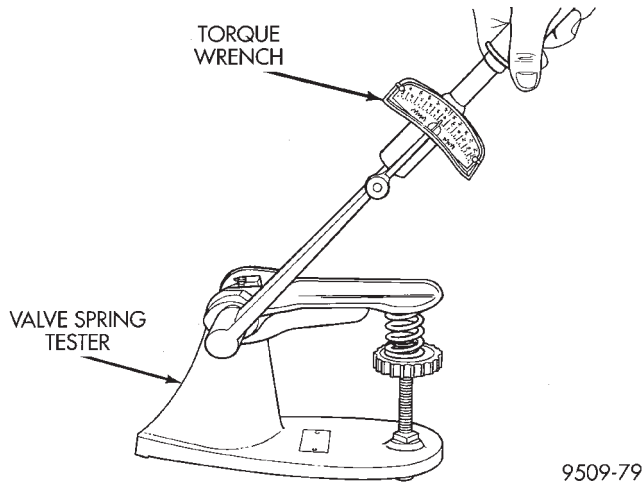


Fig. 56 Testing Valve Spring for Compressed Length

OIL PUMP

DISASSEMBLE

- (1) Remove the relief valve as follows:
 - (a) Remove cotter pin. Drill a 3.175 mm (1/8 inch) hole into the relief valve retainer cap and insert a self-threading sheet metal screw.
 - (b) Clamp screw into a vise and while supporting oil pump, remove cap by tapping pump body using a soft hammer. Discard retainer cap and remove spring and relief valve (Fig. 57).

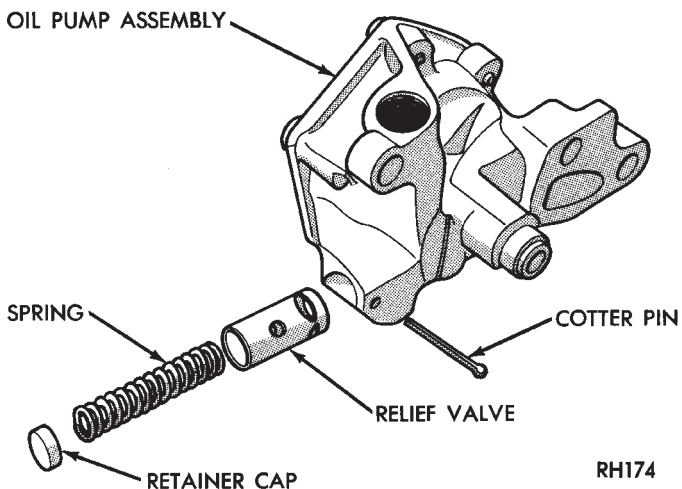


Fig. 57 Oil Pressure Relief Valve

- (2) Remove oil pump cover (Fig. 58).
- (3) Remove pump outer rotor and inner rotor with shaft (Fig. 58).

- (4) Wash all parts in a suitable solvent and inspect carefully for damage or wear.

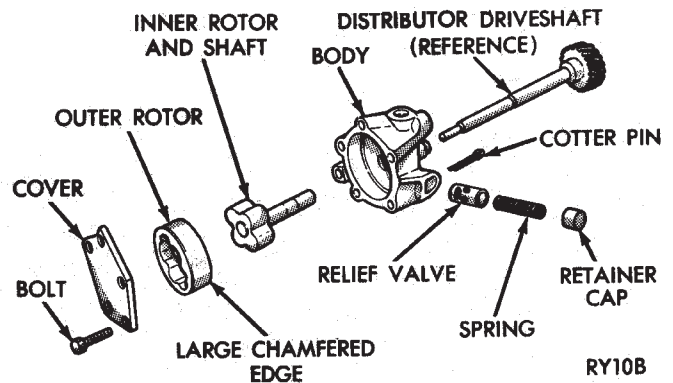


Fig. 58 Oil Pump

ASSEMBLE

- (1) Install pump rotors and shaft, using new parts as required.
- (2) Position the oil pump cover onto the pump body. Tighten cover bolts to 11 N·m (95 in. lbs.) torque.
- (3) Install the relief valve and spring. Insert the cotter pin.
- (4) Tap on a new retainer cap.
- (5) Prime oil pump before installation by filling rotor cavity with engine oil.

CYLINDER BLOCK

DISASSEMBLE

Engine assembly removed from vehicle:

- (1) Remove the cylinder head.
- (2) Remove the oil pan.
- (3) Remove the piston and connecting rod assemblies.

ASSEMBLE

- (1) Install the piston and connecting rod assembly.
- (2) Install the oil pan.
- (3) Install the cylinder head.
- (4) Install the engine into the vehicle.

CLEANING AND INSPECTION

CYLINDER HEADS

CLEANING

Clean all surfaces of cylinder block and cylinder heads.

Clean cylinder block front and rear gasket surfaces using a suitable solvent.

INSPECTION

Inspect all surfaces with a straightedge if there is any reason to suspect leakage. If out-of-flatness

CLEANING AND INSPECTION (Continued)

exceeds 0.00075 mm/mm (0.00075 inch/inch) times the span length in inches in any direction, either replace head or lightly machine the head surface.

FOR EXAMPLE: A 305 mm (12 inch) span is 0.102 mm (0.004 inch) out-of-flat. The allowable out-of-flat is 305 x 0.00075 (12 x 0.00075) equals 0.23 mm (0.009 inch). This amount of out-of-flat is acceptable.

The cylinder head surface finish should be 1.78-3.00 microns (70-125 micro inches).

Inspect push rods. Replace worn or bent rods.

PISTON AND CONNECTING ROD ASSEMBLY

INSPECTION

Check the crankshaft connecting rod journal for excessive wear, taper and scoring.

Check the cylinder block bore for out-of-round, taper, scoring and scuffing.

Check the pistons for taper and elliptical shape before they are fitted into the cylinder bore (Fig. 59).

Journal grinding should not exceed 0.305 mm (0.012 inch) under the standard journal diameter. DO NOT grind thrust faces of No.3 main bearing. DO NOT nick crank pin or bearing fillets. After grinding, remove rough edges from crankshaft oil holes and clean out all oil passages.

CAUTION: After any journal grind, it is important that the final paper or cloth polish be in the same direction as the engine rotates.

OIL PAN

CLEANING

Clean the block and pan gasket surfaces.

Trim or remove excess sealant film in the rear main cap oil pan gasket groove. **DO NOT remove the sealant inside the rear main cap slots.**

If present, trim excess sealant from inside the engine.

Clean oil pan in solvent and wipe dry with a clean cloth.

Clean oil screen and pipe thoroughly in clean solvent. Inspect condition of screen.

INSPECTION

Inspect oil drain plug and plug hole for stripped or damaged threads. Repair as necessary.

Inspect oil pan mounting flange for bends or distortion. Straighten flange, if necessary.

OIL PUMP

INSPECTION

Mating surface of the oil pump cover should be smooth. Replace pump assembly if cover is scratched or grooved.

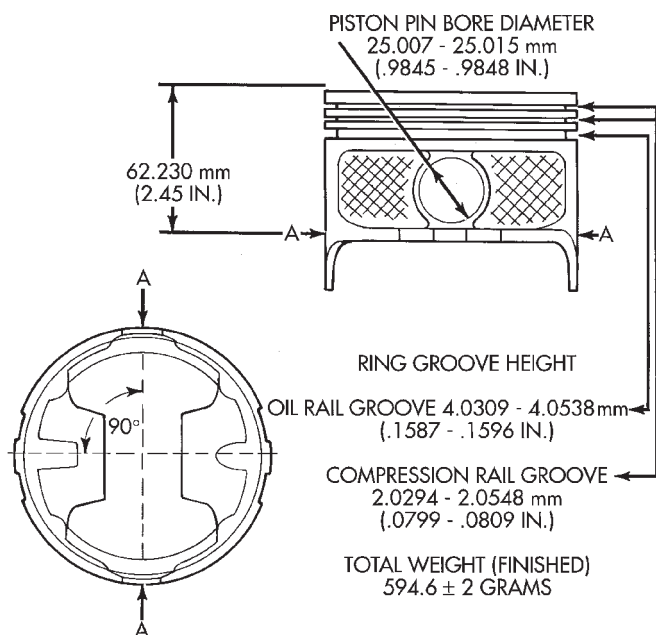
Lay a straightedge across the pump cover surface (Fig. 60). If a 0.038 mm (0.0015 inch) feeler gauge can be inserted between cover and straightedge, pump assembly should be replaced.

Measure thickness and diameter of OUTER rotor. If outer rotor thickness measures 20.9 mm (0.825 inch) or less or if the diameter is 62.7 mm (2.469 inches) or less, replace outer rotor (Fig. 61).

If inner rotor measures 20.9 mm (0.825 inch) or less, replace inner rotor and shaft assembly (Fig. 62).

Slide outer rotor into pump body. Press rotor to the side with your fingers and measure clearance between rotor and pump body (Fig. 63). If clearance is 0.356 mm (0.014 inch) or more, replace oil pump assembly.

Install inner rotor and shaft into pump body. If clearance between inner and outer rotors is 0.203 mm (0.008 inch) or more, replace shaft and both rotors (Fig. 64).



PISTON SIZE	A DIA = PISTON DIAMETER		BORE DIAMETER	
	MIN. mm (IN.)	MAX. mm (IN.)	MIN. mm (IN.)	MAX. mm (IN.)
A	99.280 (3.9087)	99.294 (3.9092)	99.306 (3.9097)	99.319 (3.9102)
B	99.294 (3.9092)	99.306 (3.9097)	99.319 (3.9102)	99.332 (3.9107)
C	99.306 (3.9097)	99.319 (3.9102)	99.332 (3.9107)	99.344 (3.9112)
D	99.319 (3.9102)	99.332 (3.9107)	99.344 (3.9112)	99.357 (3.9117)
E	99.332 (3.9107)	99.344 (3.9112)	99.357 (3.9117)	99.370 (3.9122)

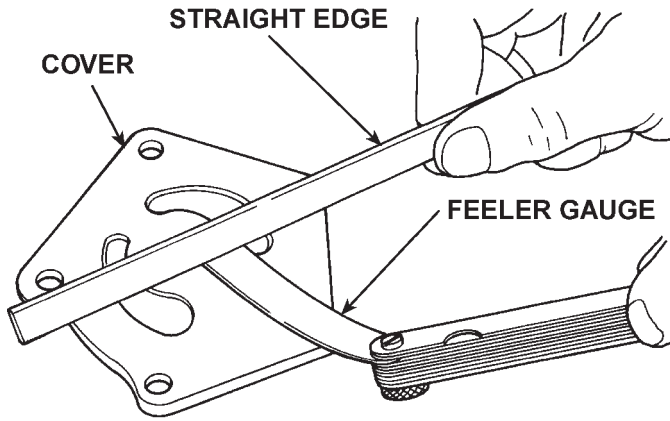
J9509-80

Fig. 59 Piston Measurements

CRANKSHAFT JOURNALS

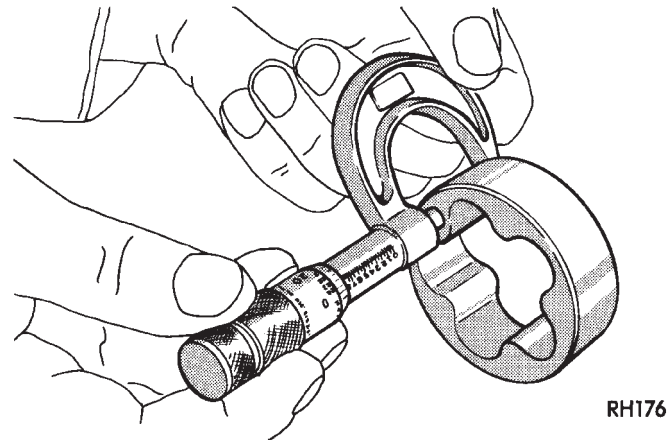
The crankshaft connecting rod and main journals should be checked for excessive wear, taper and scoring. The maximum taper or out-of-round on any crankshaft journal is 0.025 mm (0.001 inch).

CLEANING AND INSPECTION (Continued)



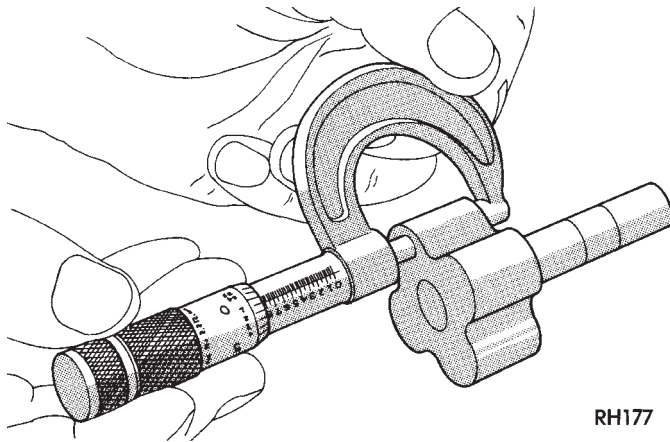
8020cd6e

Fig. 60 Checking Oil Pump Cover Flatness



RH176

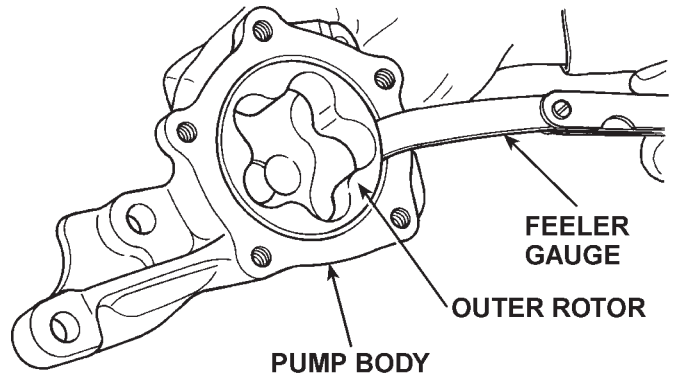
Fig. 61 Measuring Outer Rotor Thickness



RH177

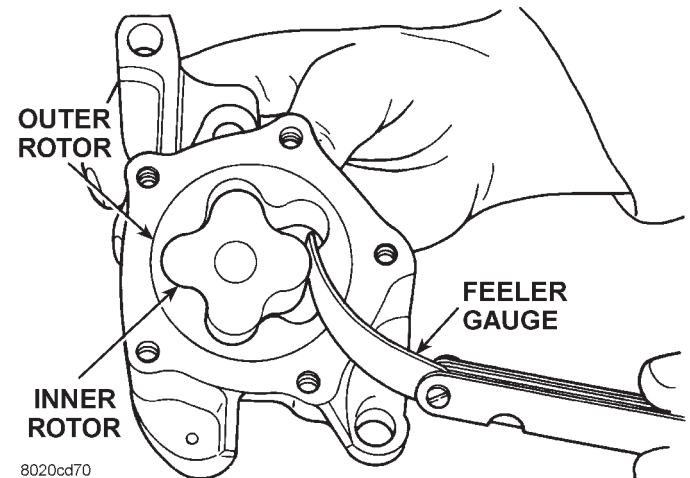
Fig. 62 Measuring Inner Rotor Thickness

Place a straightedge across the face of the pump, between bolt holes. If a feeler gauge of 0.102 mm (0.004 inch) or more can be inserted between rotors and the straightedge, replace pump assembly (Fig. 65).



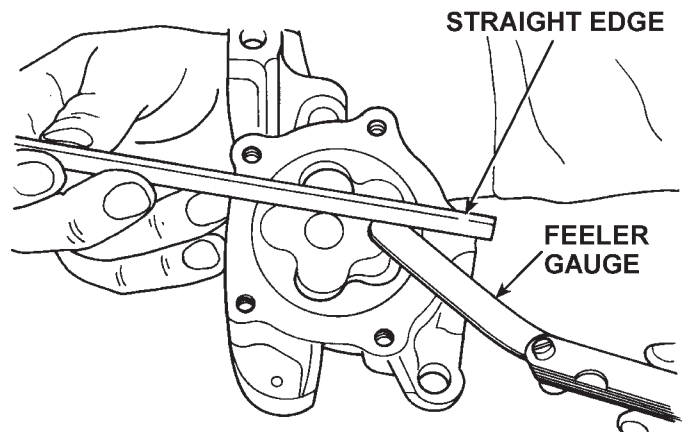
8020cd6f

Fig. 63 Measuring Outer Rotor Clearance in Housing



8020cd70

Fig. 64 Measuring Clearance Between Rotors



8020cd71

Fig. 65 Measuring Clearance Over Rotors

Inspect oil pressure relief valve plunger for scoring and free operation in its bore. Small marks may be removed with 400-grit wet or dry sandpaper.

The relief valve spring has a free length of approximately 49.5 mm (1.95 inches). The spring should test between 19.5 and 20.5 pounds when compressed

CLEANING AND INSPECTION (Continued)

to 34 mm (1-11/32 inches). Replace spring that fails to meet these specifications (Fig. 66).

If oil pressure was low and pump is within specifications, inspect for worn engine bearings or other reasons for oil pressure loss.

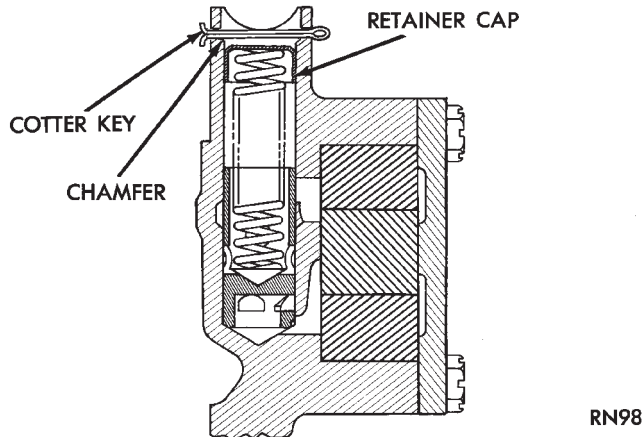


Fig. 66 Proper Installation of Retainer Cap

CYLINDER BLOCK

CLEANING

Clean cylinder block thoroughly and check all core hole plugs for evidence of leaking.

INSPECTION

Examine block for cracks or fractures.

The cylinder walls should be checked for out-of-round and taper with Cylinder Bore Indicator Tool C-119. The cylinder block should be bored and honed with new pistons and rings fitted if:

- The cylinder bores show more than 0.127 mm (0.005 in.) out-of-round.
- The cylinder bores show a taper of more than 0.254 mm (0.010 in.).
- The cylinder walls are badly scuffed or scored.

Boring and honing operation should be closely coordinated with the fitting of pistons and rings, so that specified clearances can be maintained.

OIL LINE PLUG

The oil line plug is located in the vertical passage at the rear of the block between the oil-to-filter and oil-from-filter passages (Fig. 67). Improper installation or plug missing could cause erratic, low, or no oil pressure.

The oil plug must come out the bottom. Use flat dowel, down the oil pressure sending unit hole from the top, to remove oil plug.

(1) Remove oil pressure sending unit from back of block.

(2) Insert a 3.175 mm (1/8 in.) finish wire, or equivalent, into passage.

(3) Plug should be 190.0 to 195.2 mm (7-1/2 to 7-11/16 in.) from machined surface of block (Fig. 67). If plug is too high, use a suitable flat dowel to position properly.

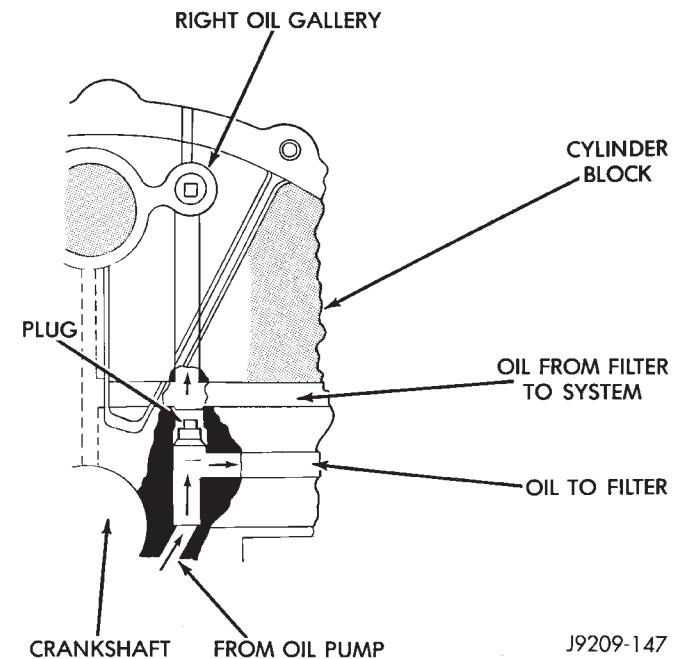


Fig. 67 Oil Line Plug

(4) If plug is too low, remove oil pan and No. 4 main bearing cap. Use suitable flat dowel to position properly. Coat outside diameter of plug with Mopar Stud and Bearing Mount Adhesive, or equivalent. Plug should be 54.0 to 57.7 mm (2-1/8 to 2-5/16 in.) from bottom of the block.

SPECIFICATIONS (Continued)**Valve Seat**

Guide Bore7950 – 7.976 mm (0.313 – 0.314 in.)
Stem to Guide Clearance00254 – 0.0762 mm (0.001 – 0.003 in.)
Service Limit (rocking method) . .	.04318 (0.017 in.)

Valve Springs

Free Length49.962 mm (1.967 in.)
Spring Tension – (valve closed) . .	.378 N @ 41.66 mm (85 lbs. @ 1.64 in.)
Spring Tension – (valve open)890 N @ 30.89 mm (200 lbs. @ 1.212 in.)
Number of Coils.6.5
Installed Height.41.66 mm (1.64 in.)
Wire Diameter4.50 mm (0.177 in.)

HYDRAULIC TAPPETS

Body Diameter22.949 – 22.962 mm (0.9035 – 0.9040 in.)
Clearance (to bore)0.0279 – 0.0610 mm (0.0011 – 0.0024 in.)
Dry Lash1.524 – 5.334 mm (0.060 – 0.210 in.)
Push Rod Length175.64 – 176.15 mm (6.915 – 6.935 in.)

OIL PRESSURE

Curb Idle (Min.)*41.4 kPa (6 psi)
3000 rpm207 – 552 kPa (30 – 80 psi)
Oil Pressure Bypass Valve Setting.62 – 103 kPa (9 – 15 psi)
Switch Actuating Pressure.34.5 – 48.3 kPa (5 – 7 psi)

CAUTION: If oil pressure is zero at curb idle, DO NOT RUN ENGINE.

OIL PUMP

Clearance over Rotors (Max.) . .	.0.1016 mm (0.004 in.)
Cover Out of Flat (Max.)0.0381 mm (0.0015 in.)
Inner Rotor Thickness (Min.)20.955 mm (0.825 in.)
Outer Rotor Clearance (Max.)0.3556 mm (0.014 in.)
Outer Rotor Diameter (Min.)62.7126 mm (2.469 in.)
Outer Rotor Thickness (Min.)20.955 mm (0.825 in.)
Tip Clearance between Rotors (Max.)0.2032 mm (0.008 in.)

PISTON PINS

Clearance at Top of Skirt0.013 – 0.038 mm (0.0005 – 0.0015 in.)
Land Clearance (Diam.)0.635 – 1.016 mm (0.025 – 0.040 in.)

Clearance at Top of Skirt0.013 – 0.038 mm (0.0005 – 0.0015 in.)
Piston Length86.360 mm (3.40 in.)
Piston Ring Groove Depth – #1&24.572 – 4.826 mm (0.180 – 0.190 in.)
Piston Ring Groove Depth – #33.810 – 4.064 mm (0.150 – 0.160 in.)
Weight.592.6 – 596.6 grams (20.90 – 21.04 oz.)

PISTON RINGS

Clearance in Piston0.00635 – 0.01905 mm (0.00025 – 0.00075 in.)
Diameter.24.996 – 25.001 mm (0.9841 – 0.9843 in.)
End PlayNONE
Length.75.946 – 76.454 mm (2.990 – 3.010 in.)

PISTON RINGS**Ring Gap**

Compression Rings0.254 – 0.508 mm (0.010 – 0.020 in.)
Oil Control (Steel Rails)0.254 – 1.270 mm (0.010 – 0.050 in.)

Ring Side Clearance

Compression Rings0.038 – 0.076 mm (0.0015 – 0.0030 in.)
Oil Ring (Steel Rails)0.06 – 0.21 mm (0.002 – 0.008 in.)

Ring Width

Compression rings1.971 – 1.989 mm (0.0776 – 0.0783 in.)
Oil Ring (Steel Rails) – Max.3.848 – 3.975 mm (0.1515 – 0.1565 in.)

VALVE TIMING**Exhaust Valve**

Closes (ATDC)21°
Opens (BBDC)60°
Duration264°

Intake Valve

Closes (ATDC)61°
Opens (BBDC)10°
Duration250°
Valve Overlap31°

SPECIFICATIONS (Continued)

OVERSIZE AND UNDERSIZE ENGINE COMPONENT MARKINGS

CONDITION	IDENTIFICATION	LOCATION OF IDENTIFICATION
CRANKSHAFT JOURNALS (UNDERSIZE) 0.0254 mm (0.001 in.)	R or M M-2-3 etc. (indicating no. 2 and 3 main bearing journal) and/or R-1-4 etc. (indicating no. 1 and 4 connecting rod journal)	Milled flat on no. 8 crankshaft counterweight.
HYDRAULIC TAPPETS (OVERSIZE) 0.2032 mm (0.008 in.)	◆	Diamond-shaped stamp top pad – front of engine and flat ground on outside surface of each O/S tappet bore.
VALVE STEMS (OVERSIZE) 0.127 mm (0.005 in.)	X	Milled pad adjacent to two tapped holes (3/8 in.) on each end of cylinder head.

J9309-82

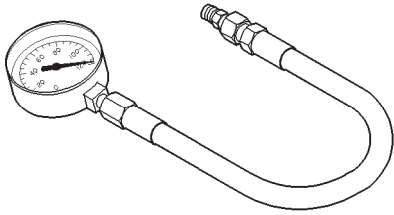
5.2L TORQUE SPECIFICATIONS

DESCRIPTION	TORQUE
Camshaft Sprocket	
Bolt68 N·m (50 ft. lbs.)
Camshaft Thrust Plate	
Bolts24 N·m (18 ft. lbs.)
Chain Case Cover	
Bolts41 N·m (30 ft. lbs.)
Connecting Rod Cap	
Bolts61 N·m (45 ft. lbs.)
Crankshaft Main Bearing Cap	
Bolts115 N·m (85 ft. lbs.)
Crankshaft Pulley	
Bolts24 N·m (210 in. lbs.)
Cylinder Head Bolts	
Step 1 – Initial68 N·m (50 ft. lbs.)
Step 2 – Final143 N·m (105 ft. lbs.)
Cylinder Head Cover	
Bolts11 N·m (95 in. lbs.)
Exhaust Manifold to Cylinder Head	
Bolts/Nuts34 N·m (25 ft. lbs.)
Flywheel	
Bolts75 N·m (55 ft. lbs.)
Front Engine Mount Bracket to Block	
Bolts81 N·m (60 ft. lbs.)
Front Engine Mount	
Through Bolt/Nut68 N·m (50 ft. lbs.)
Generator Mounting	
Bolts41 N·m (30 ft. lbs.)
Intake Manifold	
Bolts	Refer to procedure in this section
Oil Pan	
Bolts24 N·m (215 in. lbs.)

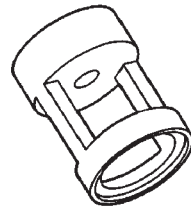
DESCRIPTION	TORQUE
Oil Pan Drain Plug	
Plug34 N·m (25 ft. lbs.)
Oil Pump	
Bolts41 N·m (30 ft. lbs.)
Oil Pump Cover	
Bolts11 N·m (95 in. lbs.)
Rear Mount Insulator to Support Bracket	
Nuts47 N·m (35 ft. lbs.)
Rear Mount Insulator to Crossmember	
Nut47 N·m (35 ft. lbs.)
Rear Support Bracket to Transmission	
Bolts102 N·m (75 ft. lbs.)
Rocker Arm	
Bolts28 N·m (21 ft. lbs.)
Spark Plugs	
Plugs41 N·m (30 ft. lbs.)
Starter Mounting	
Bolts68 N·m (50 ft. lbs.)
Thermostat Housing	
Bolts25 N·m (225 in. lbs.)
Throttle Body	
Bolts23 N·m (200 in. lbs.)
Torque Converter Drive Plate	
Bolts31 N·m (270 in. lbs.)
Transmission Support Bracket	
Bolts102 N·m (75 ft. lbs.)
Transmission Support Spacer to Insulator Mounting Plate – (4wd)	
Nuts204 N·m (150 ft. lbs.)
Vibration Damper	
Bolt183 N·m (135 ft. lbs.)
Water Pump to Chain Case Cover	
Bolt41 N·m (30 ft. lbs.)

SPECIAL TOOLS

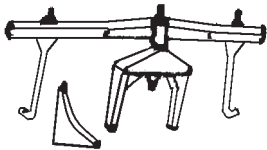
5.2L ENGINE



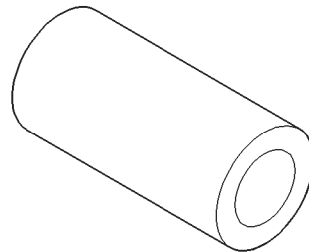
Oil Pressure Gauge C-3292



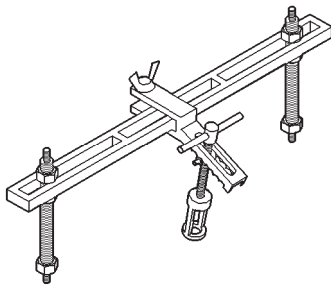
Adapter 6716A



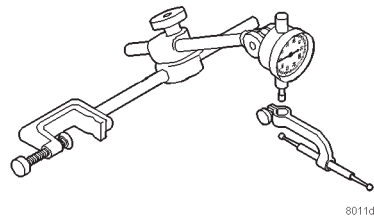
Engine Support Fixture C-3487-A



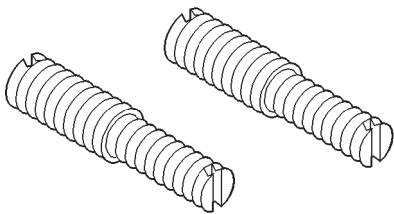
Valve Guide Sleeve C-3973



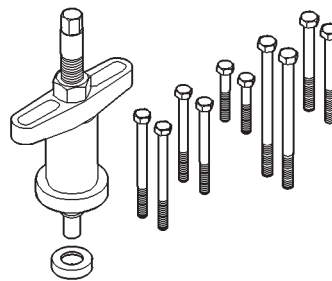
Valve Spring Compressor MD-998772-A



Dial Indicator C-3339

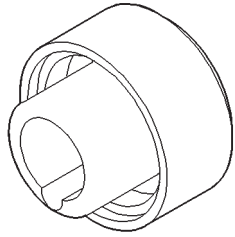


Adapter 6633

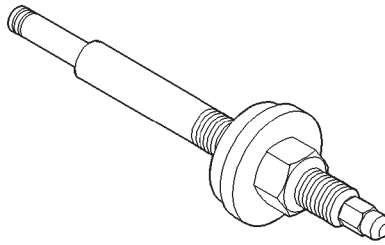


Puller C-3688

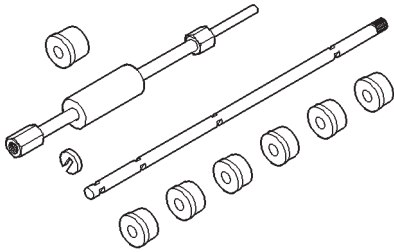
SPECIAL TOOLS (Continued)



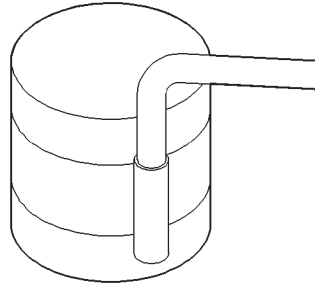
Front Oil Seal Installer 6635



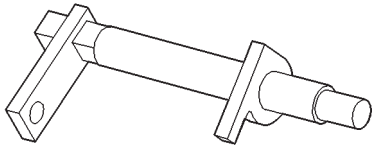
Distributor Bushing Driver/Burnisher C-3053



Cam Bearing Remover/Installer C-3132-A

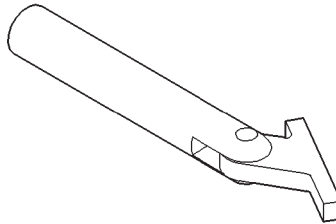


Piston Ring Compressor C-385

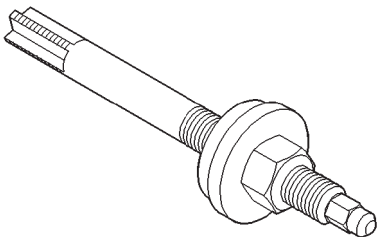


c-3509-8011d343

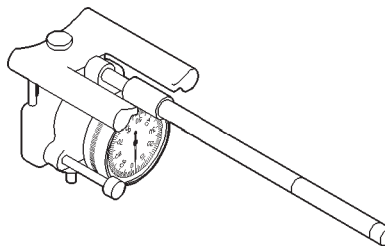
Camshaft Holder C-3509



Crankshaft Main Bearing Remover C-3059



Distributor Bushing Puller C-3052



8011c9fa

Cylinder Bore Gauge C-119

5.9L ENGINE

INDEX

	page		page
GENERAL INFORMATION			
OIL PUMP PRESSURE	88	HYDRAULIC TAPPETS	99
PISTON AND CONNECTING ROD ASSEMBLY ..	88	OIL PAN	104
DESCRIPTION AND OPERATION			
ENGINE COMPONENTS	91	OIL PUMP	106
ENGINE DESCRIPTION	88	PISTON AND CONNECTING ROD ASSEMBLY .	105
LUBRICATION SYSTEM	89	ROCKER ARMS AND PUSH RODS	97
SERVICE PROCEDURES			
CRANKSHAFT SERVICE	94	TIMING CHAIN COVER	100
FITTING CONNECTING ROD BEARINGS	93	TIMING CHAIN	101
FITTING CRANKSHAFT MAIN BEARINGS	93	VALVE SPRING AND STEM SEAL	
FITTING PISTON RINGS	92	REPLACEMENT-IN VEHICLE	97
FITTING PISTONS	92	VALVES AND VALVE SPRINGS	98
MEASURING TIMING CHAIN STRETCH	91	VIBRATION DAMPER	99
VALVE TIMING	91	DISASSEMBLY AND ASSEMBLY	
REMOVAL AND INSTALLATION			
CAMSHAFT BEARINGS	102	CYLINDER BLOCK	112
CAMSHAFT	101	HYDRAULIC TAPPETS	110
CRANKSHAFT MAIN BEARINGS	103	OIL PUMP	112
CRANKSHAFT OIL SEAL — FRONT	107	VALVE SERVICE	110
CRANKSHAFT OIL SEALS — REAR	108	CLEANING AND INSPECTION	
CRANKSHAFT	106	CRANKSHAFT JOURNALS	113
CYLINDER HEAD COVER	96	CYLINDER BLOCK	115
CYLINDER HEAD	97	CYLINDER HEADS	113
DISTRIBUTOR DRIVE SHAFT BUSHING	103	OIL PAN	113
ENGINE ASSEMBLY	96	OIL PUMP	114
ENGINE CORE OIL AND CAMSHAFT PLUGS ..	109	PISTON AND CONNECTING ROD ASSEMBLY .	113
ENGINE MOUNTS—FRONT	94	SPECIFICATIONS	
ENGINE MOUNTS—REAR	95	5.9L ENGINE SPECIFICATIONS	116
		5.9L TORQUE SPECIFICATIONS	118
		SPECIAL TOOLS	
		5.9L ENGINE	119

GENERAL INFORMATION

OIL PUMP PRESSURE

The MINIMUM oil pump pressure is 41.4 kPa (6 psi) at curb idle. The MAXIMUM oil pump pressure is 207-552 kPa (30-80 psi) at 3,000 RPM or more.

CAUTION: If oil pressure is ZERO at curb idle, DO NOT run engine.

PISTON AND CONNECTING ROD ASSEMBLY

The pistons are elliptically turned so that the diameter at the pin boss is less than its diameter across the thrust face. This allows for expansion under normal operating conditions. Under operating temperatures, expansion forces the pin bosses away from each other, causing the piston to assume a more nearly round shape.

All pistons are machined to the same weight, regardless of size, to maintain piston balance.

The piston pin rotates in the piston only and is retained by the press interference fit of the piston pin in the connecting rod.

DESCRIPTION AND OPERATION

ENGINE DESCRIPTION

The 5.9 Liter (360 CID) eight-cylinder engine is a V-Type lightweight, single cam, overhead valve engine with hydraulic roller tappets.

This engine is designed for unleaded fuel.

Engine lubrication system consists of a rotor type oil pump and a full flow oil filter.

The cylinders are numbered from front to rear; 1, 3, 5, 7 on the left bank and 2, 4, 6, 8 on the right bank. The firing order is 1-8-4-3-6-5-7-2 (Fig. 1).

DESCRIPTION AND OPERATION (Continued)

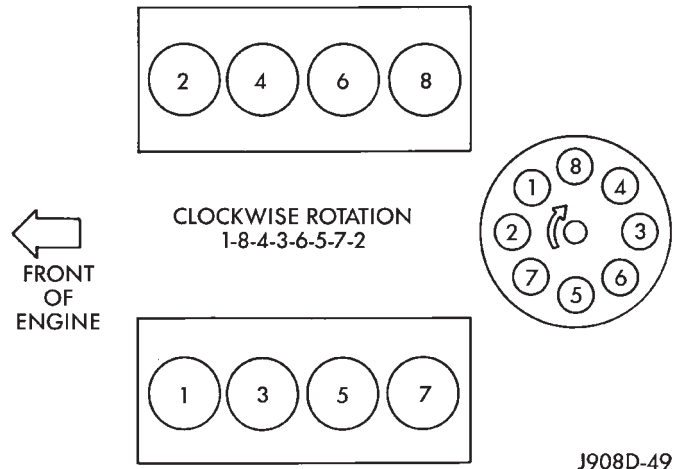


Fig. 1 Firing Order

The engine serial number is stamped into a machined pad located on the left, front corner of the cylinder block. When component part replacement is necessary, use the engine type and serial number for reference (Fig. 2).

X M 5.9L T XXXX XXXXXXXX

X = Last Digit of Model Year
 M = Plant - M Mound Road
 S Saltillo
 T Trenton
 K Toluca
 5.9L = Engine Displacement
 T = Usage - T Truck
 XXXX = Month/Day
 XXXXXXXX = Serial Code - Last 8 Digits of VIN No.

J9209-74

Fig. 2 Engine Identification Number

LUBRICATION SYSTEM

A gear-type positive displacement pump is mounted at the underside of the rear main bearing cap. The pump draws oil through the screen and inlet tube from the sump at the rear of the oil pan. The oil is driven between the drive and idler gears and pump body, then forced through the outlet to the block. An oil gallery in the block channels the oil to the inlet side of the full flow oil filter. After passing through the filter element, the oil passes from the center outlet of the filter through an oil gallery that channels the oil up to the main gallery which extends the entire length on the right side of the block. The oil then goes down to the No. 1 main bearing, back up to the left side of the block and into the oil gallery on the left side of the engine.

Galleries extend downward from the main oil gallery to the upper shell of each main bearing. The crankshaft is drilled internally to pass oil from the main bearing journals to the connecting rod journals. Each connecting rod bearing has half a hole in it, oil passes through the hole when the rods rotate and the hole lines up, oil is then thrown off as the rod rotates. This oil throw off lubricates the camshaft lobes, distributor drive gear, cylinder walls, and piston pins.

The hydraulic valve tappets receive oil directly from the main oil gallery. The camshaft bearings receive oil from the main bearing galleries. The front camshaft bearing journal passes oil through the camshaft sprocket to the timing chain. Oil drains back to the oil pan under the number one main bearing cap.

The oil supply for the rocker arms and bridged pivot assemblies is provided by the hydraulic valve tappets which pass oil through hollow push rods to a hole in the corresponding rocker arm. Oil from the rocker arm lubricates the valve train components. The oil then passes down through the push rod guide holes, and the oil drain back passages in the cylinder head past the valve tappet area, and returns to the oil pan.

DESCRIPTION AND OPERATION (Continued)

801834a9

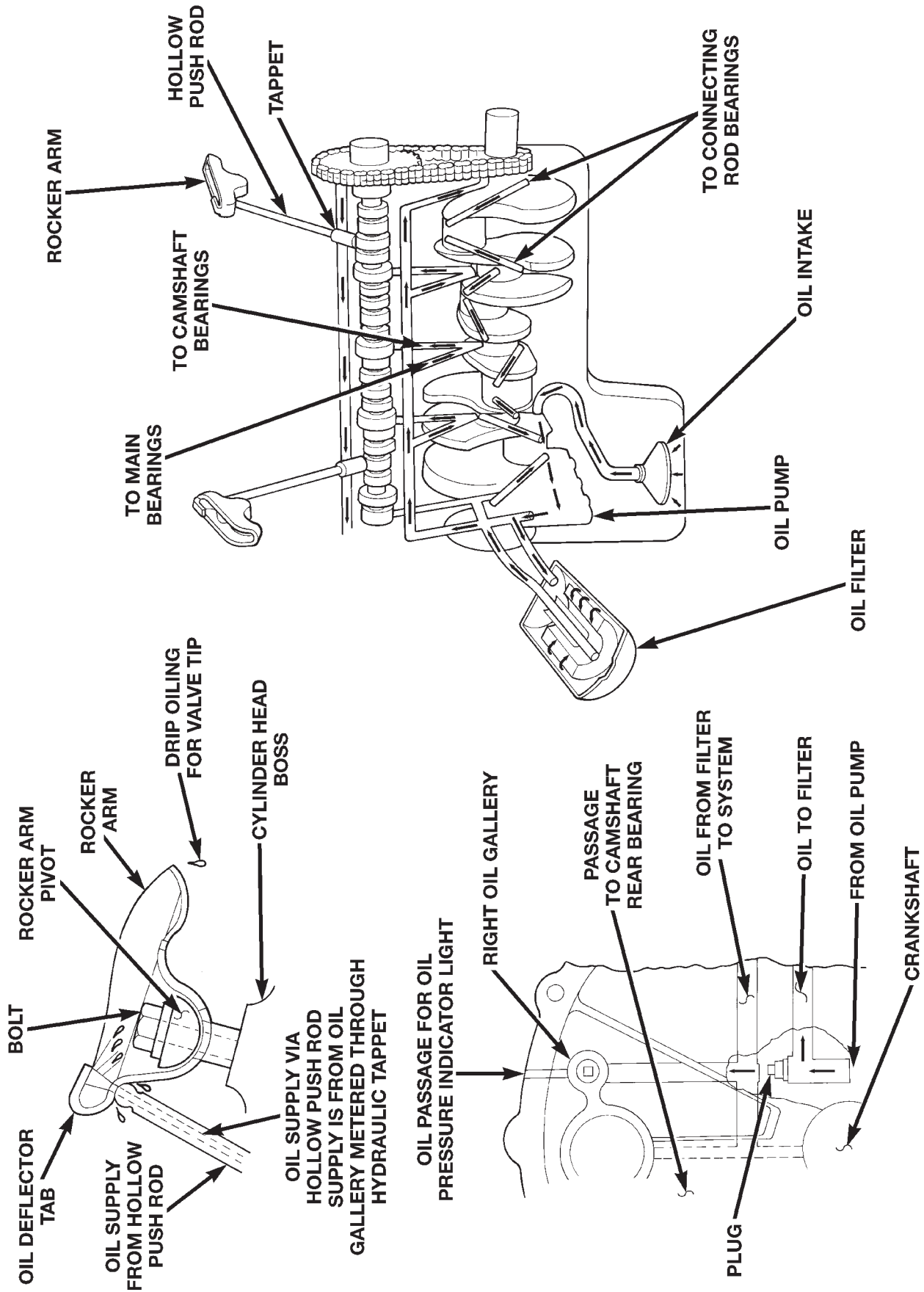


Fig. 3 Oil Lubrication System

DESCRIPTION AND OPERATION (Continued)

ENGINE COMPONENTS

CYLINDER HEADS

The alloy cast iron cylinder heads (Fig. 4) are held in place by 10 bolts. The spark plugs are located in the peak of the wedge between the valves.

The 5.9L cylinder head is identified by the foundry mark CF.

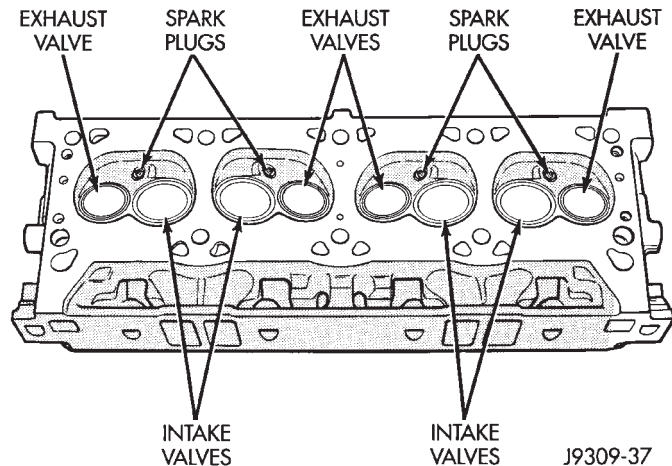


Fig. 4 Cylinder Head Assembly

PISTONS

The pistons are elliptically turned so that the diameter at the pin boss is less than its diameter across the thrust face. This allows for expansion under normal operating conditions. Under operating temperatures, expansion forces the pin bosses away from each other, causing the piston to assume a more nearly round shape.

All pistons are machined to the same weight, regardless of size, to maintain piston balance.

The piston pin rotates in the piston only and is retained by the press interference fit of the piston pin in the connecting rod.

VALVES AND VALVE SPRINGS

The valves are arranged in-line and inclined 18°. The rocker pivot support and the valve guides are cast integral with the heads.

SERVICE PROCEDURES

VALVE TIMING

(1) Turn crankshaft until the No.6 exhaust valve is closing and No.6 intake valve is opening.

(2) Insert a 6.350 mm (1/4 inch) spacer between rocker arm pad and stem tip of No.1 intake valve. Allow spring load to bleed tappet down giving in effect a solid tappet.

(3) Install a dial indicator so plunger contacts valve spring retainer as nearly perpendicular as possible. Zero the indicator.

(4) Rotate the crankshaft clockwise (normal running direction) until the valve has lifted 0.863 mm (0.034 inch). The timing of the crankshaft should now read from 10° before top dead center to 2° after top dead center. Remove spacer.

CAUTION: DO NOT turn crankshaft any further clockwise as valve spring might bottom and result in serious damage.

If reading is not within specified limits:

- Check sprocket index marks.
- Inspect timing chain for wear.
- Check accuracy of DC mark on timing indicator.

MEASURING TIMING CHAIN STRETCH

NOTE: To access timing chain Refer to Timing Chain Cover in Removal and Installation Section.

(1) Place a scale next to the timing chain so that any movement of the chain may be measured.

(2) Place a torque wrench and socket over camshaft sprocket attaching bolt. Apply torque in the direction of crankshaft rotation to take up slack; 41 N·m (30 ft. lbs.) torque with cylinder head installed or 20 N·m (15 ft. lbs.) torque with cylinder head removed. With a torque applied to the camshaft sprocket bolt, crankshaft should not be permitted to move. It may be necessary to block the crankshaft to prevent rotation.

(3) Hold a scale with dimensional reading even with the edge of a chain link. With cylinder heads installed, apply 14 N·m (30 ft. lbs.) torque in the reverse direction. With the cylinder heads removed, apply 20 N·m (15 ft. lbs.) torque in the reverse direction. Note the amount of chain movement (Fig. 5).

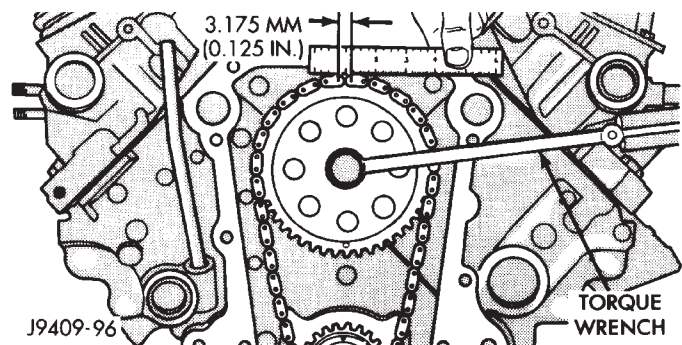


Fig. 5 Measuring Timing Chain Wear and Stretch

(4) Install a new timing chain, if its movement exceeds 3.175 mm (1/8 inch).

(5) If chain is not satisfactory, remove camshaft sprocket attaching bolt and remove timing chain with crankshaft and camshaft sprockets.

(6) Place both camshaft sprocket and crankshaft sprocket on the bench with timing marks on exact

SERVICE PROCEDURES (Continued)

imaginary center line through both camshaft and crankshaft bores.

- (7) Place timing chain around both sprockets.
- (8) Turn crankshaft and camshaft to line up with keyway location in crankshaft sprocket and in camshaft sprocket.
- (9) Lift sprockets and chain (keep sprockets tight against the chain in position as described).
- (10) Slide both sprockets evenly over their respective shafts and use a straightedge to check alignment of timing marks (Fig. 6).

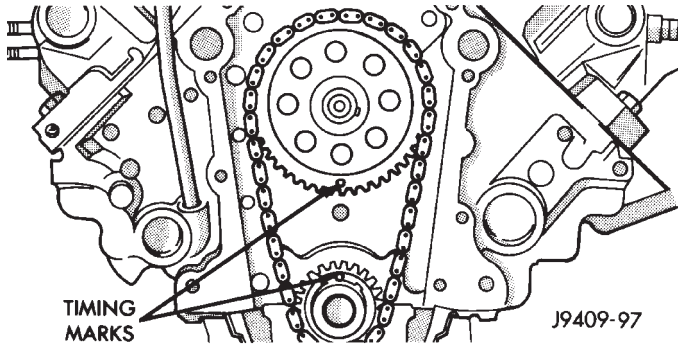


Fig. 6 Alignment of Timing Marks

- (11) Install the camshaft bolt. Tighten the bolt to 47 N·m (35 ft. lbs.) torque.
- (12) Check camshaft end play. The end play should be 0.051-0.152 mm (0.002-0.006 inch) with a new thrust plate and up to 0.254 mm (0.010 inch) with a used thrust plate. If not within these limits install a new thrust plate.

FITTING PISTONS

Piston and cylinder wall must be clean and dry. Specified clearance between the piston and the cylinder wall is 0.013-0.038 mm (0.0005-0.0015 inch) at 21°C (70°F).

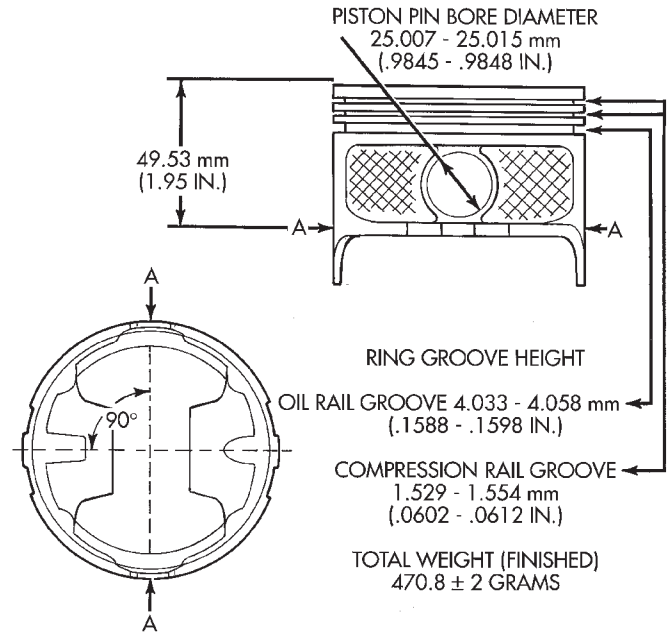
Piston diameter should be measured at the top of skirt, 90° to piston pin axis. Cylinder bores should be measured halfway down the cylinder bore and transverse to the engine crankshaft center line.

Pistons and cylinder bores should be measured at normal room temperature, 21°C (70°F).

Check the pistons for taper and elliptical shape before they are fitted into the cylinder bore (Fig. 7).

FITTING PISTON RINGS

- (1) Measurement of end gaps:
 - (a) Measure piston ring gap 2 inches from bottom of cylinder bore. An inverted piston can be used to push the rings down to ensure positioning rings squarely in the cylinder bore before measuring.
 - (b) Insert feeler gauge in the gap. The top compression ring gap should be between 0.254-0.508 mm (0.010-0.020 inch). The second compression



PISTON SIZE	A DIA = PISTON DIAMETER		BORE DIAMETER	
	MIN. mm (IN.)	MAX. mm (IN.)	MIN. mm (IN.)	MAX. mm (IN.)
A				
B	101.580 (3.9992)	101.592 (3.9997)	101.605 (4.0002)	101.618 (4.0007)
C	101.592 (3.9997)	101.605 (4.0002)	101.618 (4.0007)	101.630 (4.0012)
D	101.605 (4.0002)	101.618 (4.0007)	101.630 (4.0012)	101.643 (4.0017)
E				

J9509-79

Fig. 7 Piston Measurements

ring gap should be between 0.508-0.762 mm (0.020-0.030 inch). The oil ring gap should be 0.254-1.270 mm (0.010-0.050 inch).

(c) Rings with insufficient end gap may be properly filed to the correct dimension. Rings with excess gaps should not be used.

(2) Install rings and confirm ring side clearance:

(a) Install oil rings being careful not to nick or scratch the piston. Install the oil control rings according to instructions in the package. It is not necessary to use a tool to install the upper and lower rails. Insert oil rail spacer first, then side rails.

(b) Install the second compression rings using Installation Tool C-4184. The compression rings must be installed with the identification mark face up (toward top of piston) and chamfer facing down. An identification mark on the ring is a drill point, a stamped letter "O", an oval depression or the word TOP (Fig. 8) (Fig. 10).

(c) Using a ring installer, install the top compression ring with the chamfer facing up (Fig. 9) (Fig. 10). An identification mark on the ring is a drill point, a stamped letter "O", an oval depression or the word TOP facing up.

(d) Measure side clearance between piston ring and ring land. Clearance should be 0.074-0.097 mm

SERVICE PROCEDURES (Continued)

(0.0029-0.0038 inch) for the compression rings. The steel rail oil ring should be free in groove, but should not exceed 0.246 mm (0.0097 inch) side clearance.

(e) Pistons with insufficient or excessive side clearance should be replaced.

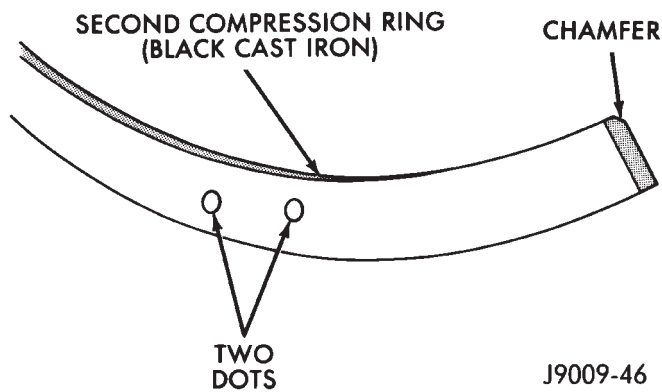


Fig. 8 Second Compression Ring Identification (Typical)

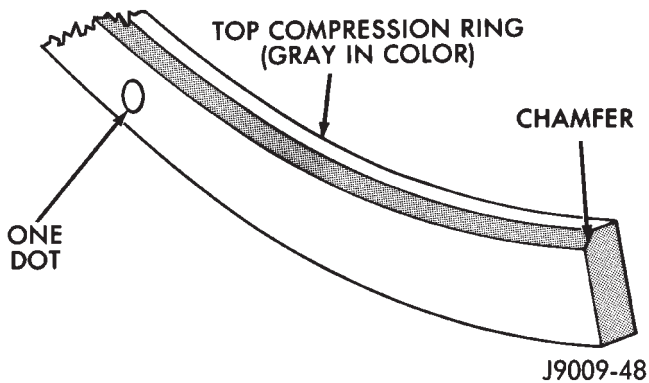


Fig. 9 Top Compression Ring Identification (Typical)

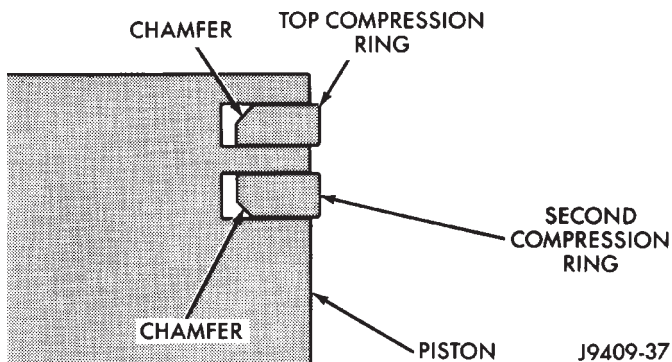


Fig. 10 Compression Ring Chamfer Location (Typical)

FITTING CONNECTING ROD BEARINGS

Fit all rods on a bank until completed. DO NOT alternate from one bank to another, because connecting rods and pistons are not interchangeable from one bank to another.

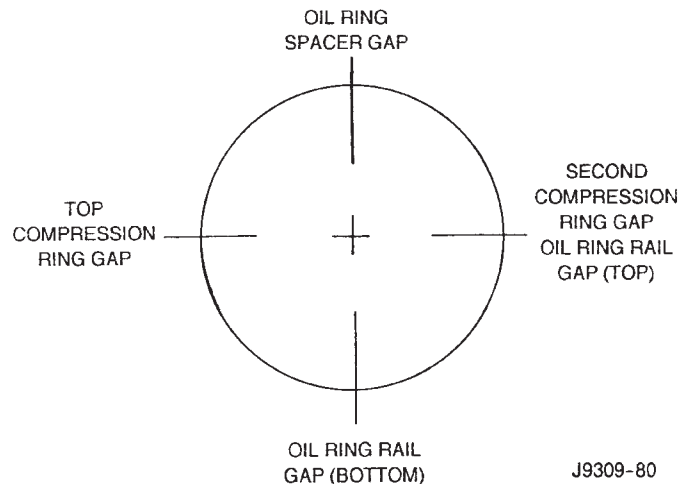


Fig. 11 Proper Ring Installation

The bearing caps are not interchangeable and should be marked at removal to ensure correct assembly.

Each bearing cap has a small V-groove across the parting face. When installing the lower bearing shell, make certain that the V-groove in the shell is in line with the V-groove in the cap. This provides lubrication of the cylinder wall in the opposite bank.

The bearing shells must be installed so that the tangs are in the machined grooves in the rods and caps.

Limits of taper or out-of-round on any crankshaft journals should be held to 0.025 mm (0.001 inch). Bearings are available in 0.025 mm (0.001 inch), 0.051 mm (0.002 inch), 0.076 mm (0.003 inch), 0.254 mm (0.010 inch) and 0.305 mm (0.012 inch) under-size. **Install the bearings in pairs. DO NOT use a new bearing half with an old bearing half. DO NOT file the rods or bearing caps.**

FITTING CRANKSHAFT MAIN BEARINGS

Bearing caps are not interchangeable and should be marked at removal to ensure correct assembly. Upper and lower bearing halves are NOT interchangeable. Lower main bearing halves of No.2 and 4 are interchangeable.

Upper and lower No.3 bearing halves are flanged to carry the crankshaft thrust loads. They are NOT interchangeable with any other bearing halves in the engine (Fig. 12). Bearing shells are available in standard and the following undersizes: 0.25 mm (0.001 inch), 0.051 mm (0.002 inch), 0.076 mm (0.003 inch), 0.254 mm (0.010 inch) and 0.305 mm (0.012 inch). Never install an undersize bearing that will reduce clearance below specifications.

SERVICE PROCEDURES (Continued)

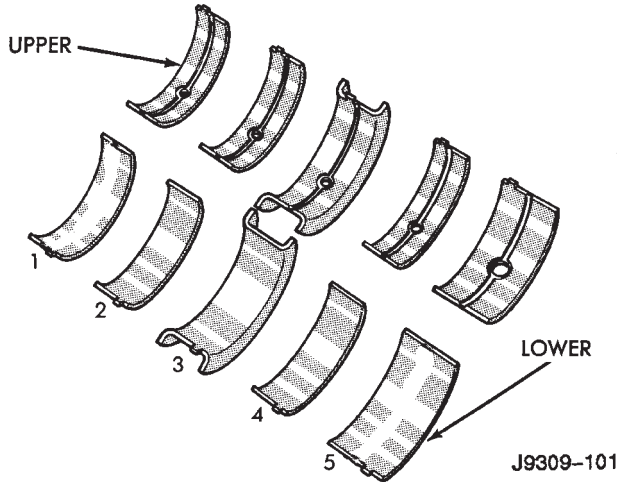


Fig. 12 Main Bearing Identification

CRANKSHAFT SERVICE

A crankshaft which has undersize journals will be stamped with 1/4 inch letters on the milled flat on the No.3 crankshaft counterweight (Fig. 13).

FOR EXAMPLE: R2 stamped on the No.3 crankshaft counterweight indicates that the No.2 rod journal is 0.025 mm (0.001 in) undersize. M4 indicates that the No.4 main journal is 0.025 mm (0.001 in) undersize. R3 M2 indicates that the No.3 rod journal and the No.2 main journal are 0.025 mm (0.001 in) undersize.

Undersize Journal	Identification Stamp
0.025 mm (0.001 inch) (Rod)	R1-R2-R3 or R4
0.025 mm (0.001 inch) (Main)	M1-M2-M3-M4 or M5

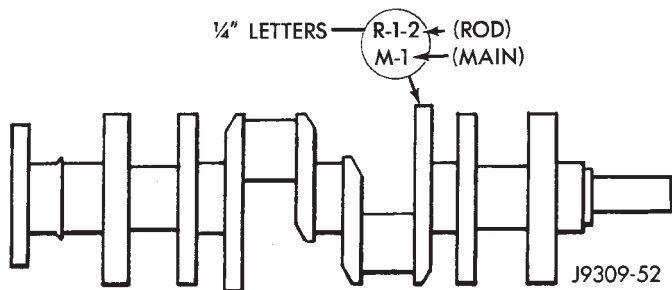


Fig. 13 Location of Crankshaft Identification

When a crankshaft is replaced, all main and connecting rod bearings should be replaced with new bearings. Therefore, selective fitting of the bearings is not required when a crankshaft and bearings are replaced.

INSPECTION OF JOURNALS

The crankshaft connecting rod and main journals should be checked for excessive wear, taper and scor-

ing. The maximum taper or out-of-round on any crankshaft journal is 0.025 mm (0.001 inch).

Journal grinding should not exceed 0.305 mm (0.012 inch) under the standard journal diameter. DO NOT grind thrust faces of No.3 main bearing. DO NOT nick crank pin or bearing fillets. After grinding, remove rough edges from crankshaft oil holes and clean out all oil passages.

CAUTION: After any journal grind, it is important that the final paper or cloth polish be in the same direction as the engine rotates.

REMOVAL AND INSTALLATION

ENGINE MOUNTS—FRONT

REMOVAL

- (1) Disconnect the negative cable from the battery.
- (2) Position fan to assure clearance for radiator top tank and hose.

CAUTION: DO NOT lift the engine by the intake manifold.

- (3) Install engine lifting fixture.
- (4) Raise vehicle on hoist.
- (5) Remove the engine support insulator thru-bolts and nuts (Fig. 14) (Fig. 15).
- (6) Raise engine SLIGHTLY. Remove the engine support insulator bolts. Remove the engine support insulator assembly.

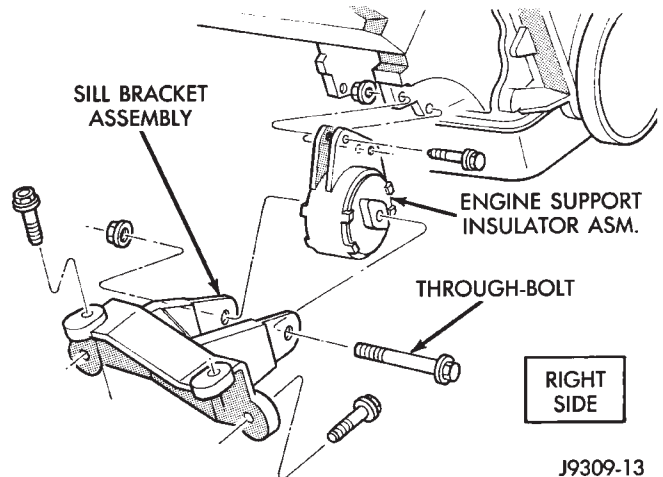


Fig. 14 Front Engine Mount—Right Side

- (7) If required, remove the sill bracket assembly.

INSTALLATION

- (1) If the sill bracket assembly was removed, install the bracket to the sill assembly.

REMOVAL AND INSTALLATION (Continued)

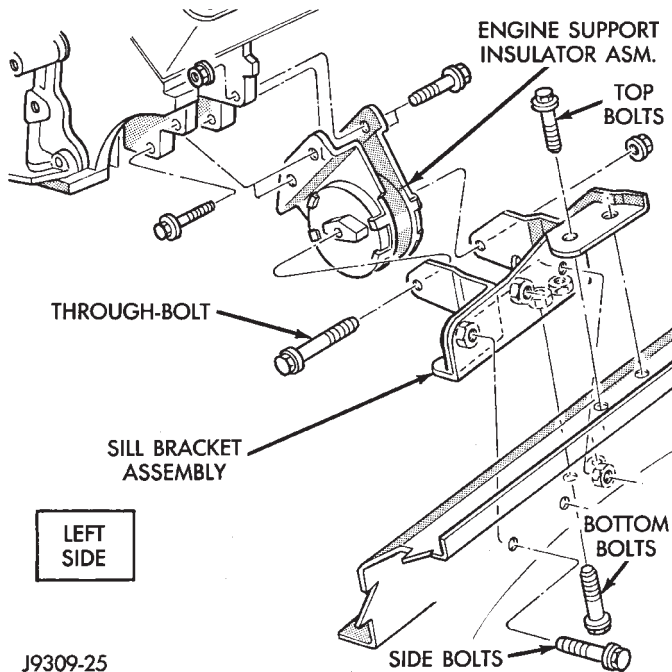


Fig. 15 Front Engine Mount—Left Side

(a) **RIGHT SIDE**—Install the sill bracket assembly onto the sill assembly (Fig. 14). Install and tighten the bolts to 65 N·m (48 ft. lbs.) torque.

(b) **LEFT SIDE**—Install the sill bracket assembly onto the sill assembly (Fig. 15). Install and tighten the 2 top bolts to 65 N·m (48 ft. lbs.) torque. Install and tighten the 2 side bolts to 95 N·m (70 ft. lbs.) torque. Install and tighten the 2 bottom bolts to 121 N·m (89 ft. lbs.) torque.

(2) With the engine raised **SLIGHTLY**, position engine support insulator assembly onto the engine block (Fig. 14) (Fig. 15). Install bolts and tighten to 88 N·m (65 ft. lbs.) torque.

(3) Lower engine with lifting fixture while aligning engine support insulator assembly into sill bracket assembly.

(4) Install the thru-bolt and nut. Tighten the **RIGHT SIDE** nut to 81 N·m (60 ft. lbs.) torque. Tighten the **LEFT SIDE** nut to 81 N·m (60 ft. lbs.) torque.

(5) Lower the vehicle.

(6) Remove lifting fixture.

(7) Connect the negative cable to the battery.

ENGINE MOUNTS—REAR

REMOVAL

- (1) Disconnect the negative cable from the battery.
- (2) Raise the vehicle and support the transmission.
- (3) Remove the bolts holding the mount assy. to the crossmember.
- (4) Raise the transmission and engine **SLIGHTLY**.

(5) Remove engine mount bracket thru-bolt and nut (Fig. 16).

(6) Remove the rear mount assy.

(7) If necessary, remove the bolts holding the rear mount bracket to the transmission. Remove the bracket from the exhaust pipe hanger. Remove the bracket.

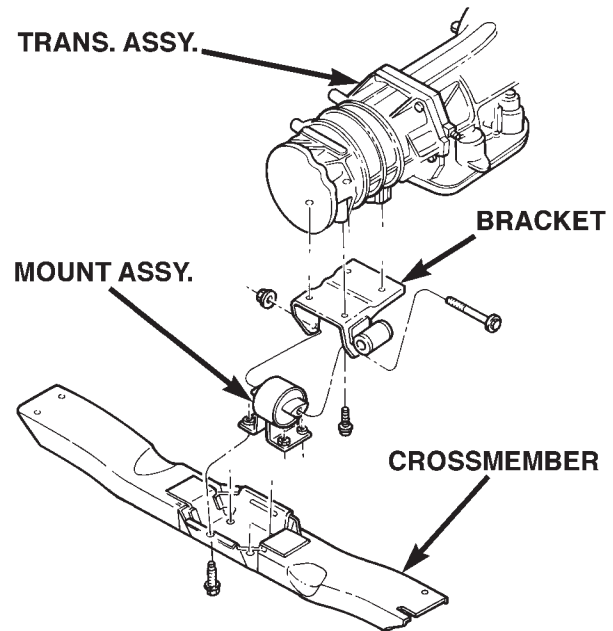


Fig. 16 Engine Rear Support Assembly

INSTALLATION

(1) Position the rear mount bracket onto the exhaust hanger (if previously removed). Position the rear mount bracket assembly onto the transmission and install the bolts. Tighten the bolts to 46 N·m (34 ft. lbs.).

(2) Position the mount into the mount bracket and install the thru-bolt and nut. **DO NOT** tighten the bolt at this time.

(3) Install the engine mount bracket assembly to the adaptor. Install the bolts and tighten to 75 N·m (55 ft. lbs.) torque.

(4) Lower the transmission until the mount fastening studs are in position in the crossmember.

(5) Remove the transmission support.

(6) Install the mount fastening nuts and tighten the nuts to 54 N·m (40 ft. lbs.) torque.

(7) Tighten the thru-bolt nut to 65 N·m (48 ft. lbs.) torque.

(8) Lower the vehicle.

(9) Connect the negative cable to the battery.

REMOVAL AND INSTALLATION (Continued)**ENGINE ASSEMBLY****REMOVAL**

- (1) Scribe hood hinge outlines on hood and remove the hood.
- (2) Remove the battery.
- (3) Drain cooling system.
- (4) Remove the air cleaner and tube.
- (5) Set fan shroud aside.
- (6) Remove radiator and heater hoses. Remove the radiator (refer to Group 7, Cooling System).
- (7) Remove the vacuum lines.
- (8) Remove the distributor cap and wiring.
- (9) Disconnect the accelerator linkage.
- (10) Perform the Fuel System Pressure Release procedure. Refer to Group 14, Fuel Systems for the correct procedure.
- (11) Disconnect the fuel supply line from the injector rail. Refer to Group 14, Fuel Systems for the correct procedure.
- (12) Remove throttle body.
- (13) Remove the starter wires.
- (14) Remove the oil pressure wire.
- (15) Discharge the air conditioning system, if equipped (refer to Group 24, Heating and Air Conditioning for service procedures).
- (16) Remove air conditioning hoses.
- (17) Disconnect the power steering hoses, if equipped.
- (18) Remove starter motor (refer to Group 8B, Battery/Starter Service).
- (19) Remove the generator (refer to Group 8C, Generator Service).
- (20) Raise and support the vehicle on a hoist.
- (21) Disconnect exhaust pipe at manifold.
- (22) Support automatic transmission with a transmission stand. This will assure that the torque converter will remain in proper position in the transmission housing.
- (23) Remove bell housing bolts and inspection plate. Attach C-clamp on front bottom of transmission torque converter housing to prevent torque converter from coming out.
- (24) Remove torque converter drive plate bolts from torque converter drive plate. Mark converter and drive plate to aid in assembly.
- (25) Disconnect the engine from the torque converter drive plate.

CAUTION: DO NOT lift the engine by the intake manifold.

- (26) Install an engine lifting fixture.
- (27) Remove the engine front mount thru-bolts.
- (28) Lower the vehicle.
- (29) Remove engine from engine compartment.
- (30) Install on engine repair stand.

INSTALLATION

- (1) Remove engine from the repair stand and position in the engine compartment.
- (2) Install engine support fixture.
- (3) Raise and support the vehicle on a hoist.
- (4) Position the torque converter and drive plate. Install torque converter drive plate bolts. Tighten the bolts to 31 N·m (270 in. lbs.) torque.
- (5) Install the engine front mount thru-bolts.
- (6) Install bell housing bolts. Tighten the bolts to 41 N·m (30 ft. lbs.) torque.
- (7) Remove C-clamp and install inspection plate.
- (8) Remove stand from transmission.
- (9) Install exhaust pipe to manifold.
- (10) Lower the vehicle.
- (11) Remove engine lifting fixture.
- (12) Install the generator (refer to Group 8C, Generator Service).
- (13) Install starter motor (refer to Group 8B, Battery/Starter Service).
- (14) Install power steering hoses, if equipped.
- (15) Install air conditioning hoses.
- (16) Charge the air conditioner, if equipped (refer to Group 24, Heater and Air Conditioning for service procedures).
- (17) Using a new gasket, install throttle body. Tighten the throttle body bolts to 23 N·m (200 in. lbs.) torque.
- (18) Connect the accelerator linkage.
- (19) Connect the starter wires.
- (20) Connect the oil pressure wire.
- (21) Install the distributor cap and wiring.
- (22) Install vacuum lines.
- (23) Install radiator, radiator hoses and heater hoses (refer to Group 7, Cooling System).
- (24) Install fan shroud in position.
- (25) Install the battery
- (26) Fill cooling system (refer to Group 7, Cooling System for the proper procedure).
- (27) Install the air cleaner.
- (28) Warm engine and adjust.
- (29) Install hood and line up.
- (30) Road test vehicle.

CYLINDER HEAD COVER

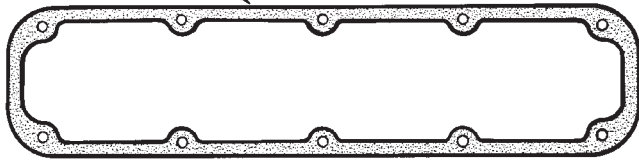
A steel backed silicon gasket is used with the cylinder head cover (Fig. 17). This gasket can be used again.

REMOVAL

- (1) Disconnect the negative cable from the battery.
- (2) Disconnect closed ventilation system and evaporation control system from cylinder head cover.
- (3) Remove cylinder head cover and gasket. The gasket may be used again.

REMOVAL AND INSTALLATION (Continued)

CYLINDER HEAD
COVER GASKET



J9209-105

Fig. 17 Cylinder Head Cover Gasket

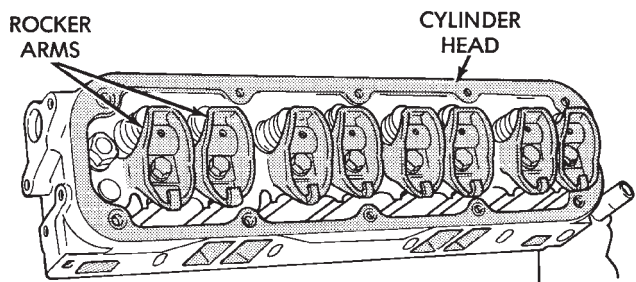
INSTALLATION

- (1) Clean cylinder head cover gasket surface.
- (2) Clean head rail, if necessary.
- (3) Inspect cover for distortion and straighten, if necessary.
- (4) Check the gasket for use in head cover installation. If damaged, use a new gasket.
- (5) Position the cylinder head cover onto the gasket. Tighten the bolts to 11 N·m (95 in. lbs.) torque.
- (6) Install closed crankcase ventilation system and evaporation control system.
- (7) Connect the negative cable to the battery.

ROCKER ARMS AND PUSH RODS

REMOVAL

- (1) Disconnect spark plug wires by pulling on the boot straight out in line with plug.
- (2) Remove cylinder head cover and gasket.
- (3) Remove the rocker arm bolts and pivots (Fig. 18). Place them on a bench in the same order as removed.
- (4) Remove the push rods and place them on a bench in the same order as removed.



J9209-65

Fig. 18 Rocker Arms

INSTALLATION

- (1) Rotate the crankshaft until the "V8" mark lines up with the TDC mark on the timing chain case cover. This mark is located 147° ATDC from the No.1 firing position.
- (2) Install the push rods in the same order as removed.

- (3) Install rocker arm and pivot assemblies in the same order as removed. Tighten the rocker arm bolts to 28 N·m (21 ft. lbs.) torque.

CAUTION: DO NOT rotate or crank the engine during or immediately after rocker arm installation. Allow the hydraulic roller tappets adequate time to bleed down (about 5 minutes).

- (4) Install cylinder head cover.
- (5) Connect spark plug wires.

VALVE SPRING AND STEM SEAL REPLACEMENT- IN VEHICLE

- (1) Set engine basic timing to Top Dead Center (TDC).
- (2) Remove the air cleaner.
- (3) Remove cylinder head covers and spark plugs.
- (4) Remove coil wire from distributor and secure to good ground to prevent engine from starting.
- (5) Using suitable socket and flex handle at crankshaft retaining bolt, turn engine so the No.1 piston is at TDC on the compression stroke.
- (6) Remove rocker arms.
- (7) With air hose attached to an adapter installed in No.1 spark plug hole, apply 620-689 kPa (90-100 psi) air pressure.
- (8) Using Valve Spring Compressor Tool MD-998772A with adaptor 6716A, compress valve spring and remove retainer valve locks and valve spring.
- (9) Install seals on the exhaust valve stem and position down against valve guides.
- (10) The intake valve stem seals should be pushed firmly and squarely over the valve guide using the valve stem as a guide. DO NOT force seal against top of guide. When installing the valve retainer locks, compress the spring only enough to install the locks.
- (11) Follow the same procedure on the remaining 7 cylinders using the firing sequence 1-8-4-3-6-5-7-2. Make sure piston in cylinder is at TDC on the valve spring that is being removed.
- (12) Remove adapter from the No.1 spark plug hole.
- (13) Install rocker arms.
- (14) Install covers and coil wire to distributor.
- (15) Install air cleaner.
- (16) Road test vehicle.

CYLINDER HEAD

REMOVAL

- (1) Disconnect the battery negative cable.
- (2) Drain cooling system (refer to Group 7, Cooling System for the proper procedures).
- (3) Remove the generator.
- (4) Remove closed crankcase ventilation system.

REMOVAL AND INSTALLATION (Continued)

- (5) Disconnect the evaporation control system.
- (6) Remove the air cleaner.
- (7) Perform the Fuel System Pressure Release procedure (refer to Group 14, Fuel System). Disconnect the fuel supply line.
- (8) Disconnect accelerator linkage and if so equipped, the speed control and transmission kick-down cables.
- (9) Remove distributor cap and wires.
- (10) Disconnect the coil wires.
- (11) Disconnect heat indicator sending unit wire.
- (12) Disconnect heater hoses and bypass hose.
- (13) Remove cylinder head covers and gaskets.
- (14) Remove intake manifold and throttle body as an assembly. Discard the flange side gaskets and the front and rear cross-over gaskets.
- (15) Remove exhaust manifolds.
- (16) Remove rocker arm assemblies and push rods. Identify to ensure installation in original locations.
- (17) Remove the head bolts from each cylinder head and remove cylinder heads. Discard the cylinder head gasket.
- (18) Remove spark plugs.

INSTALLATION

- (1) Position the new cylinder head gaskets onto the cylinder block.
- (2) Position the cylinder heads onto head gaskets and cylinder block.
- (3) Starting at top center, tighten all cylinder head bolts, in sequence, to 68 N·m (50 ft. lbs.) torque (Fig. 19). Repeat procedure, tighten all cylinder head bolts to 143 N·m (105 ft. lbs.) torque. Repeat procedure to confirm that all bolts are at 143 N·m (105 ft. lbs.) torque.

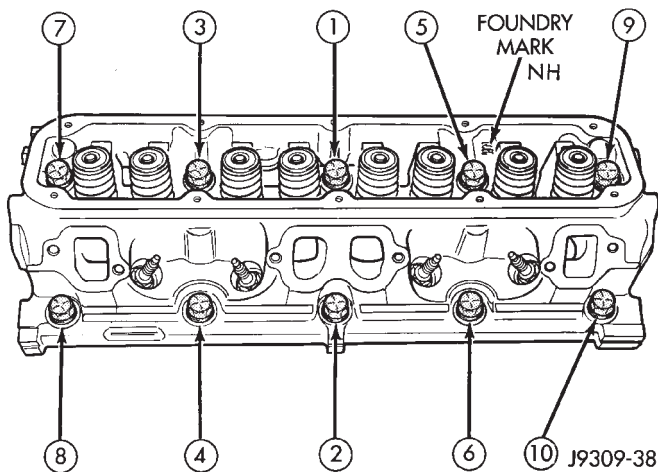


Fig. 19 Cylinder Head Bolt Tightening Sequence

CAUTION: When tightening the rocker arm bolts, make sure the piston in that cylinder is NOT at TDC. Contact between the valves and piston could occur.

- (4) Install push rods and rocker arm assemblies in their original position. Tighten the bolts to 28 N·m (21 ft. lbs.) torque.
- (5) Install the intake manifold and throttle body assembly (refer to Group 11, Exhaust System and Intake Manifold).
- (6) Install exhaust manifolds. Tighten the bolts and nuts to 34 N·m (25 ft. lbs.) torque.
- (7) Adjust spark plugs to specifications (refer to Group 8D, Ignition System). Install the plugs and tighten to 41 N·m (30 ft. lbs.) torque.
- (8) Install coil wires.
- (9) Connect heat indicator sending unit wire.
- (10) Connect the heater hoses and bypass hose.
- (11) Install distributor cap and wires.
- (12) Connect the accelerator linkage and if so equipped, the speed control and transmission kick-down cables.
- (13) Install the fuel supply line.
- (14) Install the generator and drive belt. Tighten generator mounting bolt to 41 N·m (30 ft. lbs.) torque. Tighten the adjusting strap bolt to 23 N·m (200 in. lbs.) torque. Refer to Group 7, Cooling System for adjusting the belt tension.
- (15) Install the intake manifold-to-generator bracket support rod. Tighten the bolts.
- (16) Place the cylinder head cover gaskets in position and install cylinder head covers. Tighten the bolts to 11 N·m (95 in. lbs.) torque.
- (17) Install closed crankcase ventilation system.
- (18) Connect the evaporation control system.
- (19) Install the air cleaner.
- (20) Fill cooling system (refer to Group 7, Cooling System for proper procedure).
- (21) Connect the negative cable to the battery.

VALVES AND VALVE SPRINGS**REMOVAL**

- (1) Remove the cylinder head.
- (2) Compress valve springs using Valve Spring Compressor Tool MD- 998772A and adapter 6716A.
- (3) Remove valve retaining locks, valve spring retainers, valve stem seals and valve springs.
- (4) Before removing valves, remove any burrs from valve stem lock grooves to prevent damage to the valve guides. Identify valves to ensure installation in original location.

INSTALLATION

- (1) Clean valves thoroughly. Discard burned, warped and cracked valves.
- (2) Remove carbon and varnish deposits from inside of valve guides with a reliable guide cleaner.
- (3) Measure valve stems for wear. If wear exceeds 0.051 mm (0.002 inch), replace the valve.

REMOVAL AND INSTALLATION (Continued)

(4) Coat valve stems with lubrication oil and insert them in cylinder head.

(5) If valves or seats are reground, check valve stem height. If valve is too long, replace cylinder head.

(6) Install new seals on all valve guides. Install valve springs and valve retainers.

(7) Compress valve springs with Valve Spring Compressor Tool MD-998772A and adapter 6716A, install locks and release tool. If valves and/or seats are ground, measure the installed height of springs. Make sure the measurement is taken from bottom of spring seat in cylinder head to the bottom surface of spring retainer. If spacers are installed, measure from the top of spacer. If height is greater than 42.86 mm (1-11/16 inches), install a 1.587 mm (1/16 inch) spacer in head counterbore. This should bring spring height back to normal 41.27 to 42.86 mm (1-5/8 to 1-11/16 inch).

HYDRAULIC TAPPETS

REMOVAL

- (1) Remove the air cleaner.
- (2) Remove cylinder head cover, rocker assembly and push rods. Identify push rods to ensure installation in original location.
- (3) Remove intake manifold, yoke retainer and aligning yokes.
- (4) Slide Hydraulic Tappet Remover/Installer Tool C-4129-A through opening in cylinder head and seat tool firmly in the head of tappet.
- (5) Pull tappet out of bore with a twisting motion. If all tappets are to be removed, identify tappets to ensure installation in original location.

INSTALLATION

- (1) If the tappet or bore in cylinder block is scored, scuffed, or shows signs of sticking, ream the bore to next oversize. Replace with oversize tappet.
- (2) Lubricate tappets.
- (3) Install tappets and push rods in their original positions. Ensure that the oil feed hole in the side of the tappet body faces up (away from the crankshaft).
- (4) Install aligning yokes with ARROW toward camshaft.
- (5) Install yoke retainer. Tighten the bolts to 23 N·m (200 in. lbs.) torque. Install intake manifold.
- (6) Install push rods in original positions.
- (7) Install rocker arm.
- (8) Install cylinder head cover.
- (9) Start and operate engine. Warm up to normal operating temperature.

CAUTION: To prevent damage to valve mechanism, engine must not be run above fast idle until all

hydraulic tappets have filled with oil and have become quiet.

VIBRATION DAMPER

REMOVAL

- (1) Disconnect the negative cable from the battery.
- (2) Remove fan shroud retainer bolts and set shroud back over engine.
- (3) Remove the cooling system fan.
- (4) Remove the serpentine belt (refer to Group 7, Cooling System).
- (5) Remove the vibration damper pulley.
- (6) Remove vibration damper bolt and washer from end of crankshaft.
- (7) Install bar and screw from Puller Tool Set C-3688. Install 2 bolts with washers through the puller tool and into the vibration damper (Fig. 20).

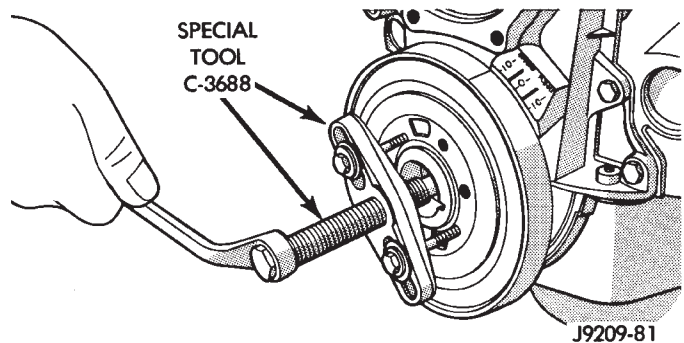


Fig. 20 Vibration Damper Assembly

- (8) Pull vibration damper off of the crankshaft.

INSTALLATION

- (1) Position the vibration damper onto the crankshaft.
- (2) Place installing tool, part of Puller Tool Set C-3688 in position and press the vibration damper onto the crankshaft (Fig. 21).

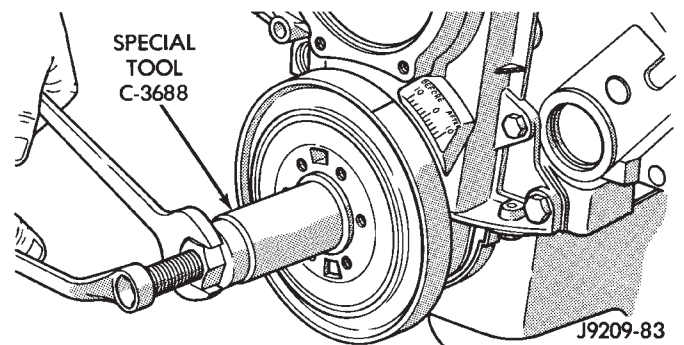


Fig. 21 Installing Vibration Damper

- (3) Install the crankshaft bolt and washer. Tighten the bolt to 183 N·m (135 ft. lbs.) torque.

REMOVAL AND INSTALLATION (Continued)

(4) Install the crankshaft pulley. Tighten the pulley bolts to 23 N·m (200 in. lbs.) torque.

(5) Install the serpentine belt (refer to Group 7, Cooling System).

(6) Install the cooling system fan. Tighten the bolts to 23 N·m (17 ft. lbs.) torque.

(7) Position the fan shroud and install the bolts. Tighten the retainer bolts to 11 N·m (95 in. lbs.) torque.

(8) Connect the negative cable to the battery.

TIMING CHAIN COVER**REMOVAL**

(1) Disconnect the negative cable from the battery.

(2) Drain cooling system (refer to Group 7, Cooling System).

(3) Remove the serpentine belt (refer to Group 7, Cooling System).

(4) Remove water pump (refer to Group 7, Cooling System).

(5) Remove power steering pump (refer to Group 19, Steering).

(6) Remove vibration damper.

(7) Loosen oil pan bolts and remove the front bolt at each side.

(8) Remove the cover bolts.

(9) Remove chain case cover and gasket using extreme caution to avoid damaging oil pan gasket.

(10) Place a suitable tool behind the lips of the oil seal to pry the oil seal outward. Be careful not to damage the crankshaft seal surface of cover (Fig. 22).

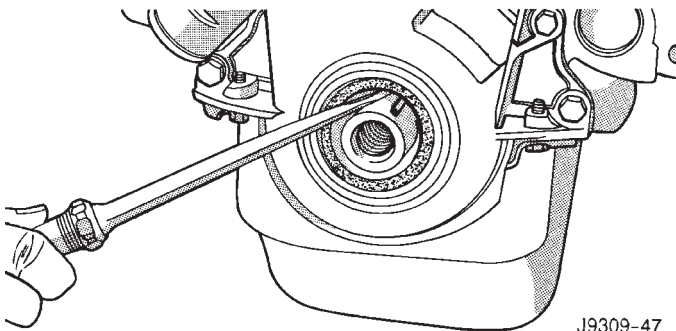


Fig. 22 Removal of Front Crankshaft Oil Seal

INSTALLATION

(1) Using a new cover gasket, carefully install chain case cover to avoid damaging oil pan gasket. Use a small amount of Mopar® Silicone Rubber Adhesive Sealant, or equivalent, at the joint between timing chain cover gasket and the oil pan gasket. Finger tighten the timing chain cover bolts at this time.

(2) Place the smaller diameter of the oil seal over Front Oil Seal Installation Tool 6635 (Fig. 23). Seat the oil seal in the groove of the tool.

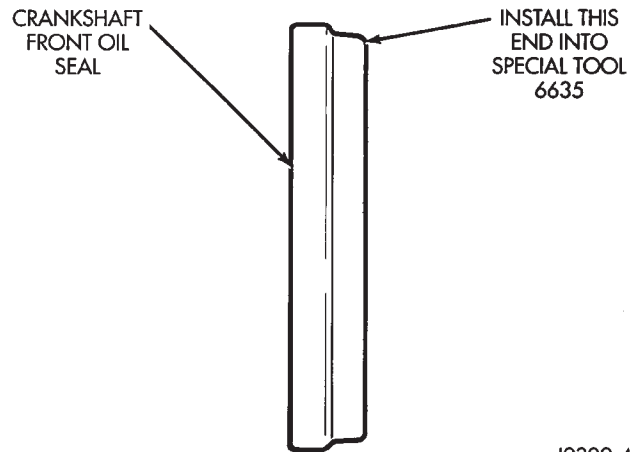


Fig. 23 Placing Oil Seal on Installation Tool 6635

(3) Position the seal and tool onto the crankshaft (Fig. 24).

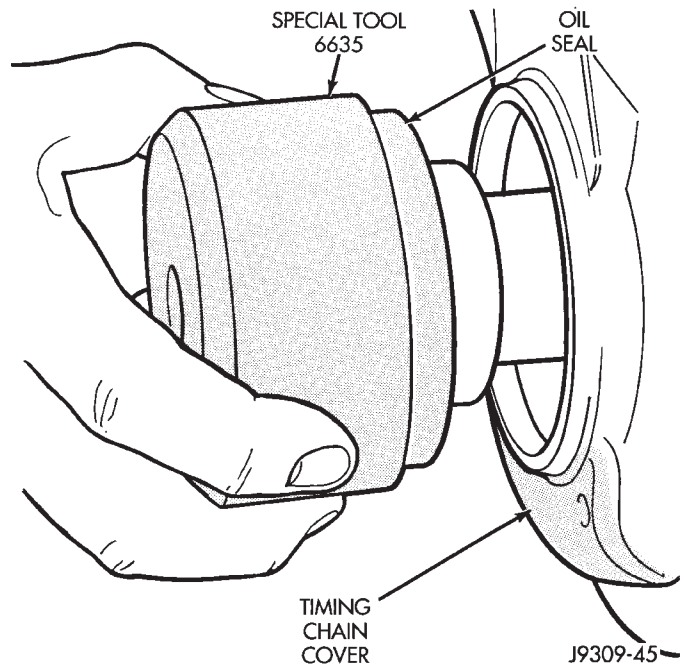


Fig. 24 Position Tool and Seal onto Crankshaft

(4) Tighten the 4 lower chain case cover bolts to 13N·m (10 ft.lbs.) to prevent the cover from tipping during seal installation.

(5) Using the vibration damper bolt, tighten the bolt to draw the seal into position on the crankshaft (Fig. 25).

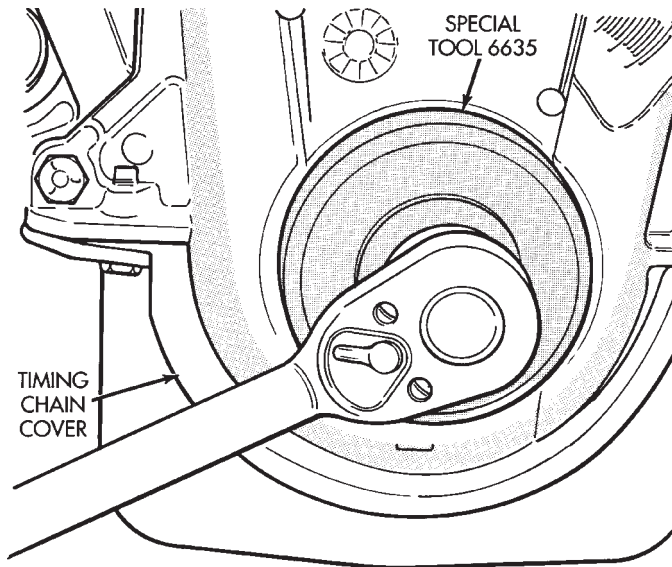
(6) Loosen the 4 bolts tightened in step 4 to allow realignment of front cover assembly.

(7) Tighten chain case cover bolts to 41 N·m (30 ft. lbs.) torque. Tighten oil pan bolts to 24 N·m (215 in. lbs.) torque.

(8) Remove the vibration damper bolt and seal installation tool.

(9) Install vibration damper.

REMOVAL AND INSTALLATION (Continued)



J9309-46

Fig. 25 Installing Oil Seal

(10) Install water pump and housing assembly using new gaskets (refer to Group 7, Cooling System). Tighten bolts to 41 N·m (30 ft. lbs.) torque.

(11) Install power steering pump (refer to Group 19, Steering).

(12) Install the serpentine belt (refer to Group 7, Cooling System).

(13) Install the cooling system fan. Tighten the bolts to 23 N·m (17 ft. lbs.) torque.

(14) Position the fan shroud and install the bolts. Tighten the bolts to 11 N·m (95 in. lbs.) torque.

(15) Fill cooling system (refer to Group 7, Cooling System for the proper procedure).

(16) Connect the negative cable to the battery.

TIMING CHAIN

REMOVAL

(1) Remove Timing Chain Cover Refer to procedure in this section.

(2) Remove camshaft sprocket attaching bolt and remove timing chain with crankshaft and camshaft sprockets.

INSTALLATION

(1) Place both camshaft sprocket and crankshaft sprocket on the bench with timing marks on exact imaginary center line through both camshaft and crankshaft bores.

(2) Place timing chain around both sprockets.

(3) Turn crankshaft and camshaft to line up with keyway location in crankshaft sprocket and in camshaft sprocket.

(4) Lift sprockets and chain (keep sprockets tight against the chain in position as described).

(5) Slide both sprockets evenly over their respective shafts and use a straightedge to check alignment of timing marks (Fig. 26).

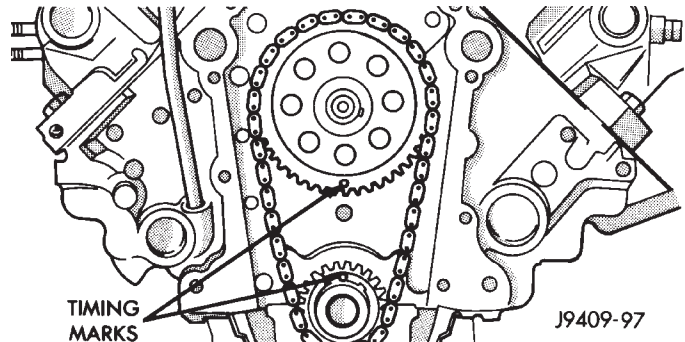


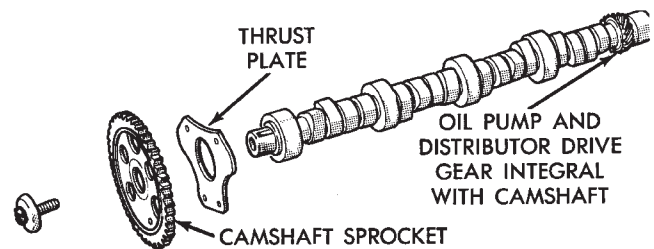
Fig. 26 Alignment of Timing Marks

(6) Install the camshaft bolt. Tighten the bolt to 68 N·m (50 ft. lbs.) torque.

(7) Check camshaft end play. The end play should be 0.051-0.152 mm (0.002-0.006 inch) with a new thrust plate and up to 0.254 mm (0.010 inch) with a used thrust plate. If not within these limits install a new thrust plate.

CAMSHAFT

NOTE: The camshaft has an integral oil pump and distributor drive gear (Fig. 27).



J9309-71

Fig. 27 Camshaft and Sprocket Assembly

REMOVAL

(1) Remove intake manifold.

(2) Remove cylinder head covers.

(3) Remove timing case cover and timing chain.

(4) Remove rocker arms.

(5) Remove push rods and tappets. Identify each part so it can be installed in its original location.

(6) Remove distributor and lift out the oil pump and distributor drive shaft.

(7) Remove camshaft thrust plate, note location of oil tab (Fig. 28).

(8) Install a long bolt into front of camshaft to facilitate removal of the camshaft. Remove camshaft,

REMOVAL AND INSTALLATION (Continued)

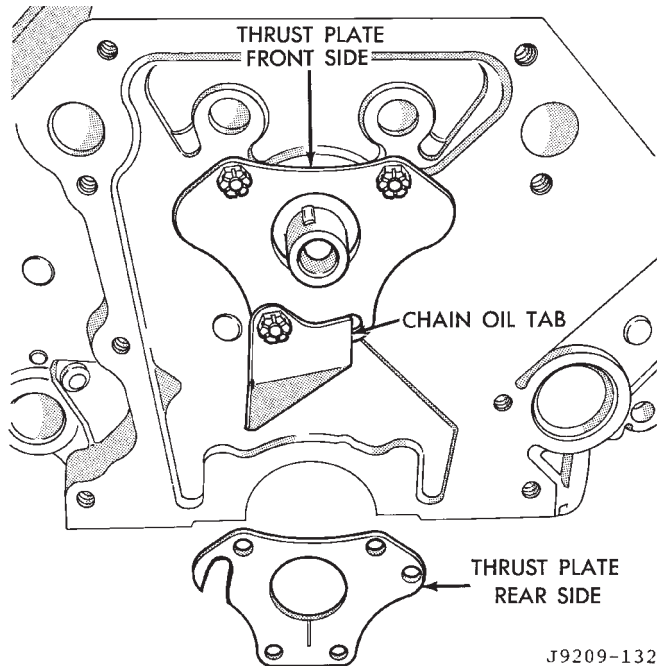


Fig. 28 Timing Chain Oil Tab Installation

being careful not to damage cam bearings with the cam lobes.

INSTALLATION

(1) Lubricate camshaft lobes and camshaft bearing journals and insert the camshaft to within 51 mm (2 inches) of its final position in cylinder block.

NOTE: Whenever an engine has been rebuilt, a new camshaft and/or new tappets installed, add 1 pint of Mopar Crankcase Conditioner, or equivalent. The oil mixture should be left in engine for a minimum of 805 km (500 miles). Drain at the next normal oil change.

(2) Install Camshaft Gear Installer Tool C-3509 with tongue back of distributor drive gear (Fig. 29).

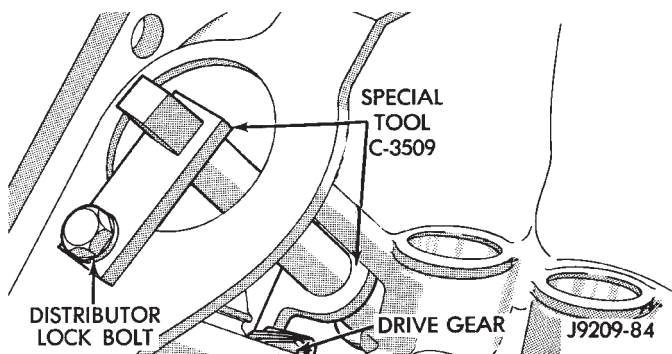


Fig. 29 Camshaft Holding Tool C-3509 (Installed Position)

(3) Hold tool in position with a distributor lock-plate bolt. This tool will restrict camshaft from being

pushed in too far and prevent knocking out the welch plug in rear of cylinder block. **Tool should remain installed until the camshaft and crankshaft sprockets and timing chain have been installed.**

(4) Install camshaft thrust plate and chain oil tab. **Make sure tang enters lower right hole in thrust plate.** Tighten bolts to 24 N·m (210 in. lbs.) torque. Top edge of tab should be flat against thrust plate in order to catch oil for chain lubrication.

(5) Place both camshaft sprocket and crankshaft sprocket on the bench with timing marks on exact imaginary center line through both camshaft and crankshaft bores.

(6) Place timing chain around both sprockets.

(7) Turn crankshaft and camshaft to line up with keyway location in crankshaft sprocket and in camshaft sprocket.

(8) Lift sprockets and chain (keep sprockets tight against the chain in position as described).

(9) Slide both sprockets evenly over their respective shafts and use a straightedge to check alignment of timing marks (Fig. 30).

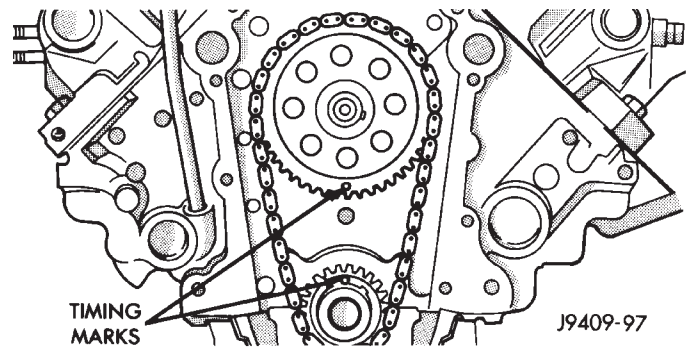


Fig. 30 Alignment of Timing Marks

(10) Install the camshaft bolt/cup washer. Tighten bolt to 68 N·m (50 ft. lbs.) torque.

(11) Measure camshaft end play. Refer to Specifications for proper clearance. If not within limits install a new thrust plate.

(12) Each tappet reused must be installed in the same position from which it was removed. **When camshaft is replaced, all of the tappets must be replaced.**

CAMSHAFT BEARINGS

REMOVAL

NOTE: This procedure requires that the engine is removed from the vehicle.

(1) With engine completely disassembled, drive out rear cam bearing core hole plug.

(2) Install proper size adapters and horseshoe washers (part of Camshaft Bearing Remover/Installer

REMOVAL AND INSTALLATION (Continued)

Tool C-3132-A) at back of each bearing shell. Drive out bearing shells (Fig. 31).

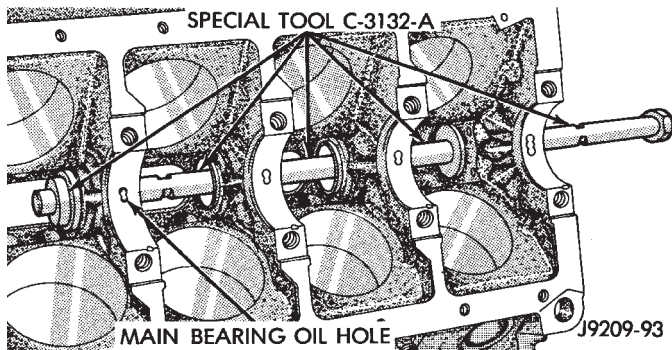


Fig. 31 Camshaft Bearings Removal/Installation with Tool C-3132-A

INSTALLATION

- (1) Install new camshaft bearings with Camshaft Bearing Remover/Installer Tool C-3132-A by sliding the new camshaft bearing shell over proper adapter.
- (2) Position rear bearing in the tool. Install horseshoe lock and by reversing removal procedure, carefully drive bearing shell into place.
- (3) Install remaining bearings in the same manner. Bearings must be carefully aligned to bring oil holes into full register with oil passages from the main bearing. If the camshaft bearing shell oil holes are not in exact alignment, remove and install them correctly. Install a new core hole plug at the rear of camshaft. **Be sure this plug does not leak.**

CRANKSHAFT MAIN BEARINGS

REMOVAL

- (1) Remove the oil pan.
- (2) Remove the oil pump from the rear main bearing cap.
- (3) Identify bearing caps before removal. Remove bearing caps one at a time.
- (4) Remove upper half of bearing by inserting Crankshaft Main Bearing Remover/Installer Tool C-3059 into the oil hole of crankshaft (Fig. 32).
- (5) Slowly rotate crankshaft clockwise, forcing out upper half of bearing shell.

INSTALLATION

Only one main bearing should be selectively fitted while all other main bearing caps are properly tightened. All bearing capbolts removed during service procedures are to be cleaned and oiled before installation.

When installing a new upper bearing shell, slightly chamfer the sharp edges from the plain side.

- (1) Start bearing in place, and insert Crankshaft Main Bearing Remover/Installer Tool C-3059 into oil hole of crankshaft (Fig. 32).

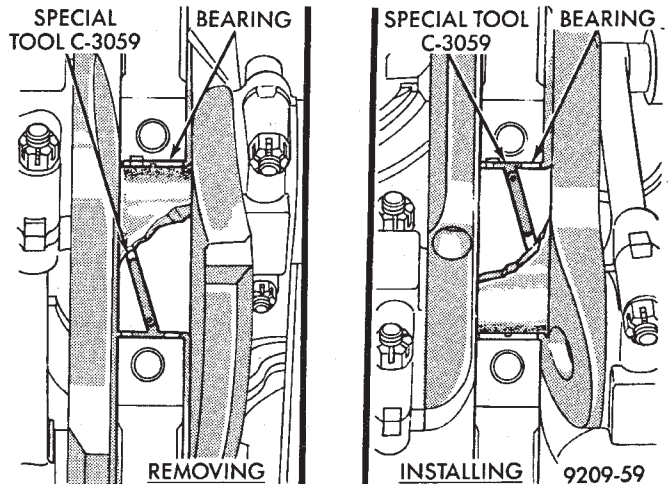


Fig. 32 Upper Main Bearing Removal and Installation with Tool C-3059

- (2) Slowly rotate crankshaft counterclockwise sliding the bearing into position. Remove Tool C-3059.
- (3) Install the bearing caps. Clean and oil the bolts. Tighten the capbolts to 115 N·m (85 ft. lbs.) torque.
- (4) Install the oil pump.
- (5) Install the oil pan.

DISTRIBUTOR DRIVE SHAFT BUSHING

REMOVAL

- (1) Remove distributor, refer to Group 8D, Ignition Systems for the proper procedure.
- (2) Remove the intake manifold (refer to Group 11, Exhaust System and Intake Manifold).
- (3) Insert Distributor Drive Shaft Bushing Puller Tool C-3052 into old bushing and thread down until a tight fit is obtained (Fig. 33).
- (4) Hold puller screw and tighten puller nut until bushing is removed.

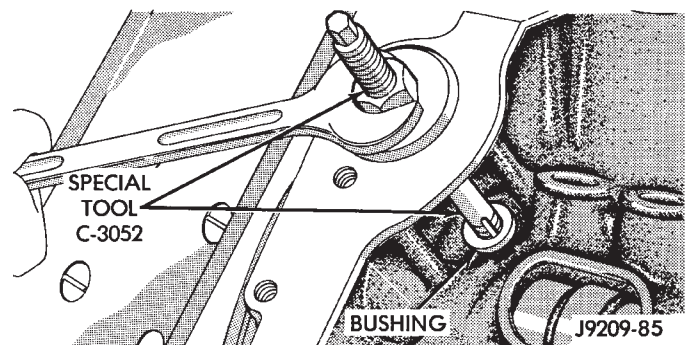


Fig. 33 Distributor Driveshaft Bushing Removal

INSTALLATION

- (1) Slide new bushing over burnishing end of Distributor Drive Shaft Bushing Driver/Burnisher Tool C-3053. Insert the tool and bushing into the bore.

REMOVAL AND INSTALLATION (Continued)

(2) Drive bushing and tool into position, using a hammer (Fig. 34).

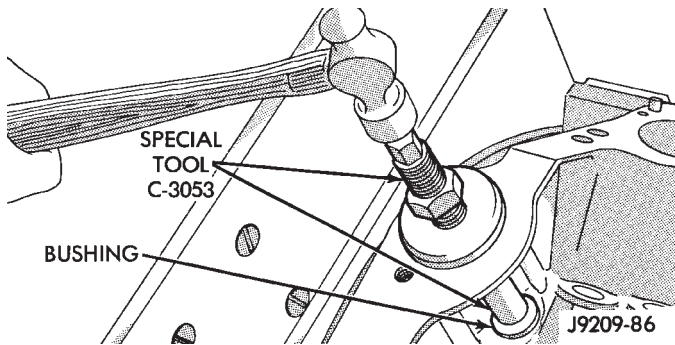


Fig. 34 Distributor Driveshaft Bushing Installation

(3) As the burnisher is pulled through the bushing, the bushing is expanded tight in the block and burnished to correct size (Fig. 35). **DO NOT ream this bushing.**

CAUTION: This procedure **MUST** be followed when installing a new bushing or seizure to shaft may occur.

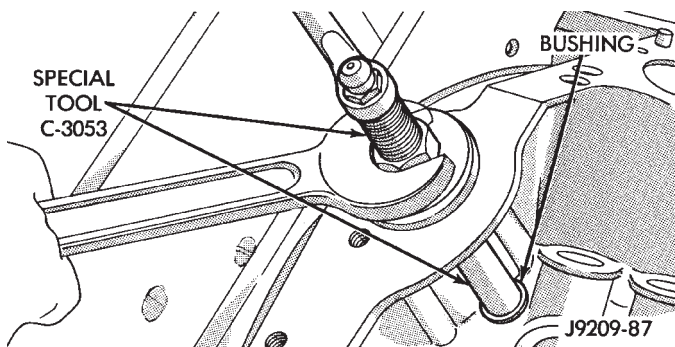


Fig. 35 Burnishing Distributor Driveshaft Bushing

(4) Install the intake manifold (refer to Group 11, Exhaust System and Intake Manifold).

DISTRIBUTOR INSTALLATION

NOTE: Before installing the distributor, the oil pump drive shaft must be aligned to number one cylinder.

(1) Rotate crankshaft until No.1 cylinder is at top dead center on the firing stroke.

(2) When in this position, the timing mark of vibration damper should be under "0" on the timing indicator.

(3) Install the shaft so that after the gear spirals into place, it will index with the oil pump shaft. The slot on top of oil pump shaft should be aligned towards the left front intake manifold attaching bolt hole (Fig. 36).

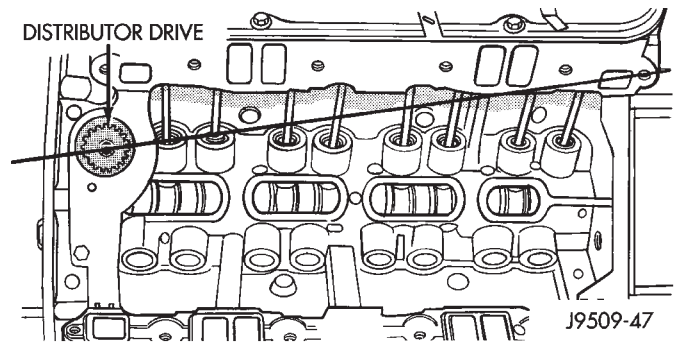


Fig. 36 Position of Oil Pump Shaft Slot

(4) Install distributor, refer to Group 8D, Ignition Systems for the proper procedure.

After the distributor has been installed, its rotational position must be set using the **SET SYNC** mode of the DRB scan tool. Refer to Checking Distributor Position following the Distributor Installation section in Group 8D, Ignition system.

Do not attempt to adjust ignition timing by rotating the distributor. It has no effect on ignition timing. Adjusting distributor position will effect fuel synchronization only.

OIL PAN

REMOVAL

- (1) Disconnect the negative cable from the battery.
- (2) Raise the vehicle.
- (3) Remove the oil pan drain plug and drain the engine oil.
- (4) Remove the oil filter.
- (5) Remove the starter (refer to Group 8B, Battery/Starter/Generator Service).
- (6) If equipped with an oil level sensor, disconnect the sensor.
- (7) Position the cooler lines out of the way.
- (8) Disconnect the oxygen sensor.
- (9) Remove exhaust pipe.
- (10) Remove the oil pan bolts. Carefully slide the oil pan and gasket to the rear. If equipped with an oil level sensor, take care not to damage the sensor.

INSTALLATION

(1) Fabricate 4 alignment dowels from 5/16 x 1 1/2 inch bolts. Cut the head off the bolts and cut a slot into the top of the dowel. This will allow easier installation and removal with a screwdriver (Fig. 37).

(2) Install the dowels in the cylinder block (Fig. 38).

(3) Apply small amount of Mopar® Silicone Rubber Adhesive Sealant, or equivalent in the corner of the cap and the cylinder block.

(4) Slide the one-piece gasket over the dowels and onto the block.

REMOVAL AND INSTALLATION (Continued)

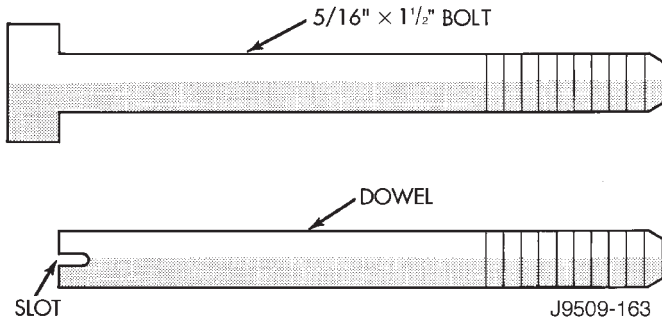


Fig. 37 Fabrication of Alignment Dowels

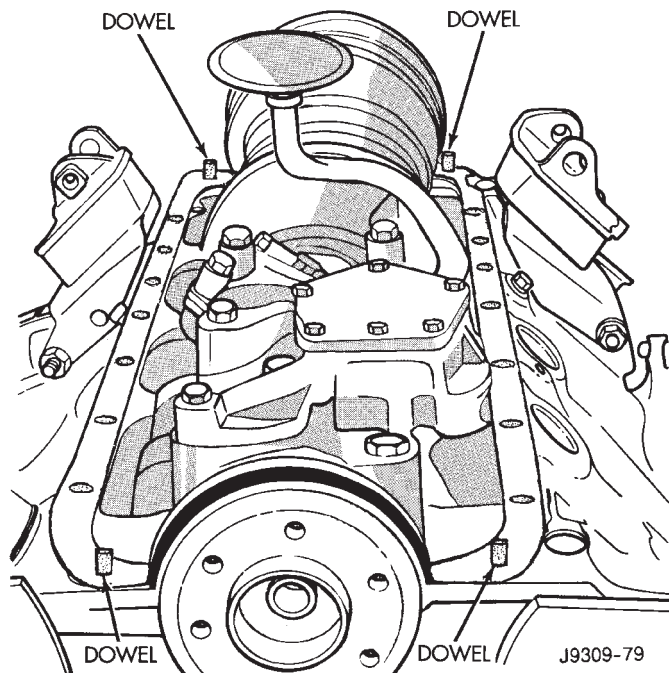


Fig. 38 Position of Dowels in Cylinder Block

(5) Position the oil pan over the dowels and onto the gasket. If equipped with an oil level sensor, take care not to damage the sensor.

(6) Install the oil pan bolts. Tighten the bolts to 24 N·m (215 in. lbs.) torque.

(7) Remove the dowels. Install the remaining oil pan bolts. Tighten these bolts to 24 N·m (215 in. lbs.) torque.

(8) Install the drain plug. Tighten drain plug to 34 N·m (25 ft. lbs.) torque.

(9) Install exhaust pipe.

(10) Connect the oxygen sensor.

(11) Install the oil filter.

(12) If equipped with an oil level sensor, connect the sensor.

(13) Install the starter (refer to Group 8B, Battery/Starter/Generator Service).

(14) Move the cooler lines back into position.

(15) Lower vehicle.

(16) Connect the negative cable to the battery.

(17) Fill the oil pan with engine oil to the specified level.

WARNING: USE EXTREME CAUTION WHEN THE ENGINE IS OPERATING. DO NOT STAND IN A DIRECT LINE WITH THE FAN. DO NOT PUT YOUR HANDS NEAR THE PULLEYS, BELTS OR FAN. DO NOT WEAR LOOSE CLOTHING.

(18) Start the engine and inspect for leaks.

PISTON AND CONNECTING ROD ASSEMBLY

REMOVAL

(1) Remove the engine from the vehicle.

(2) Remove the cylinder head.

(3) Remove the oil pan.

(4) Remove top ridge of cylinder bores with a reliable ridge reamer before removing pistons from cylinder block. Be sure to keep tops of pistons covered during this operation.

(5) Be sure the connecting rod and connecting rod cap are identified with the cylinder number. Remove connecting rod cap. Install connecting rod bolt guide set on connecting rod bolts.

(6) Pistons and connecting rods must be removed from top of cylinder block. When removing piston and connecting rod assemblies, rotate crankshaft to center the connecting rod in the cylinder bore and at BDC. **Be careful not to nick crankshaft journals.**

(7) After removal, install bearing cap on the mating rod.

INSTALLATION

(1) Be sure that compression ring gaps are staggered so that neither is in-line with oil ring rail gap.

(2) Before installing the ring compressor, make sure the oil ring expander ends are butted and the rail gaps located properly (Fig. 39).

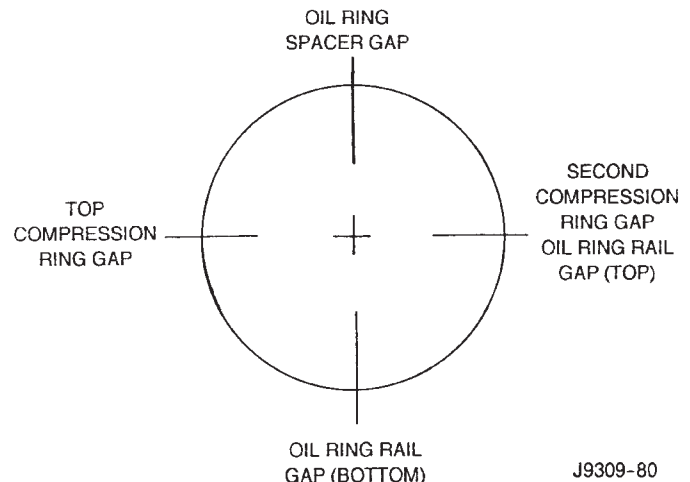


Fig. 39 Proper Ring Installation

REMOVAL AND INSTALLATION (Continued)

(3) Immerse the piston head and rings in clean engine oil. Slide Piston Ring Compressor Tool C-385 over the piston and tighten with the special wrench (part of Tool C-385). **Be sure position of rings does not change during this operation.**

(4) Install connecting rod bolt protectors on rod bolts, the long protector should be installed on the numbered side of the connecting rod.

(5) Rotate crankshaft so that the connecting rod journal is on the center of the cylinder bore. Be sure connecting rod and cylinder bore number are the same. Insert rod and piston into cylinder bore and guide rod over the crankshaft journal.

(6) Tap the piston down in cylinder bore, using a hammer handle. At the same time, guide connecting rod into position on crankshaft journal.

(7) The notch or groove on top of piston must be pointing toward front of engine. The larger chamfer of the connecting rod bore must be installed toward crankshaft journal fillet.

(8) Install rod caps. Be sure connecting rod, connecting rod cap and cylinder bore number are the same. Install nuts on cleaned and oiled rod bolts and tighten nuts to 61 N·m (45 ft. lbs.) torque.

(9) Install the oil pan.

(10) Install the cylinder head.

(11) Install the engine into the vehicle.

CRANKSHAFT

REMOVAL

- (1) Remove the oil pan.
- (2) Remove the oil pump from the rear main bearing cap.
- (3) Remove the vibration damper.
- (4) Remove the timing chain cover.
- (5) Identify bearing caps before removal. Remove bearing caps and bearings one at a time.
- (6) Lift the crankshaft out of the block.
- (7) Remove and discard the crankshaft rear oil seals.
- (8) Remove and discard the front crankshaft oil seal.

INSTALLATION

- (1) Clean Loctite 518 residue and sealant from the cylinder block and rear cap mating surface. Do this before applying the Loctite drop and the installation of rear cap.
- (2) Lightly oil the new upper seal lips with engine oil.
- (3) Install the new upper rear bearing oil seal with the white paint facing towards the rear of the engine.
- (4) Position the crankshaft into the cylinder block.
- (5) Lightly oil the new lower seal lips with engine oil.

(6) Install the new lower rear bearing oil seal into the bearing cap with the white paint facing towards the rear of the engine.

(7) Apply 5 mm (0.20 in) drop of Loctite 518, or equivalent, on each side of the rear main bearing cap (Fig. 40). DO NOT over apply sealant or allow the sealant to contact the rubber seal. Assemble bearing cap to cylinder block immediately after sealant application.

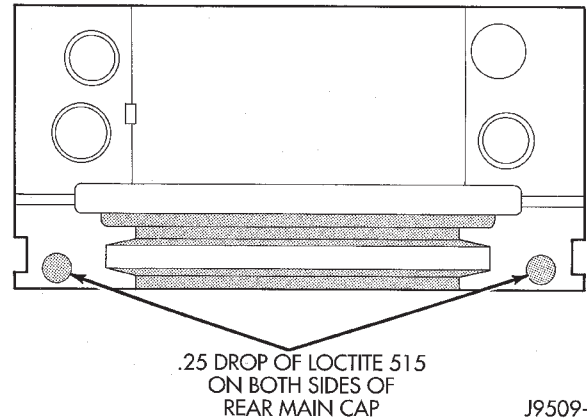


Fig. 40 Sealant Application to Bearing Cap

(8) To align the bearing cap, use cap slot, alignment dowel and cap bolts. DO NOT remove excess material after assembly. DO NOT strike rear cap more than 2 times for proper engagement.

(9) Clean and oil all cap bolts. Install all main bearing caps. Install all cap bolts and alternately tighten to 115 N·m (85 ft. lbs.) torque.

(10) Install oil pump.

(11) Install the timing chain cover.

(12) Install the vibration damper.

(13) Apply Mopar® Silicone Rubber Adhesive Sealant, or equivalent, at bearing cap to block joint to provide cap to block and oil pan sealing (Fig. 41). Apply enough sealant until a small amount is squeezed out. Withdraw nozzle and wipe excess sealant off the oil pan seal groove.

(14) Install new front crankshaft oil seal.

(15) Immediately install the oil pan.

OIL PUMP

REMOVAL

- (1) Remove the oil pan.
- (2) Remove the oil pump from rear main bearing cap.

INSTALLATION

(1) Install oil pump. During installation slowly rotate pump body to ensure driveshaft-to-pump rotor shaft engagement.

REMOVAL AND INSTALLATION (Continued)

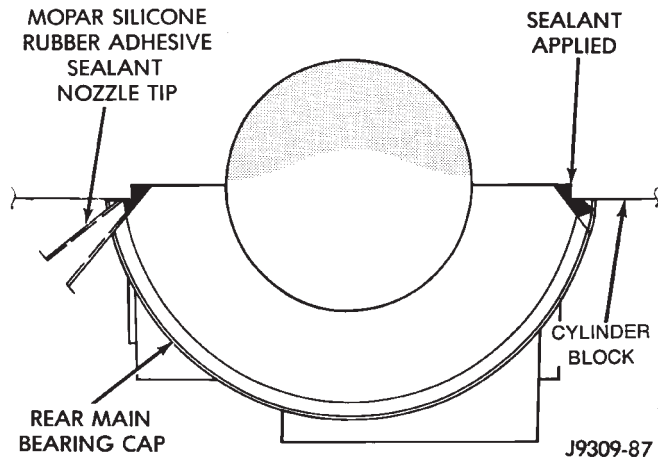


Fig. 41 Apply Sealant to Bearing Cap to Block Joint

(2) Hold the oil pump base flush against mating surface on No.5 main bearing cap. Finger tighten pump attaching bolts. Tighten attaching bolts to 41 N·m (30 ft. lbs.) torque.

(3) Install the oil pan.

CRANKSHAFT OIL SEAL — FRONT

The oil seal can be replaced without removing the timing chain cover provided the cover is not misaligned.

(1) Disconnect the negative cable from the battery.

(2) Remove vibration damper.

(3) If front seal is suspected of leaking, check front oil seal alignment to crankshaft. The seal installation/alignment tool 6635, should fit with minimum interference. If tool does not fit, the cover must be removed and installed properly.

(4) Place a suitable tool behind the lips of the oil seal to pry the oil seal outward. Be careful not to damage the crankshaft seal bore of cover.

(5) Place the smaller diameter of the oil seal over Front Oil Seal Installation Tool 6635 (Fig. 42). Seat the oil seal in the groove of the tool.

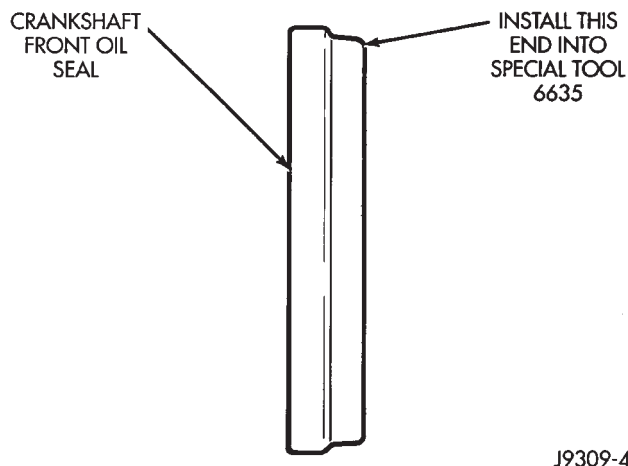


Fig. 42 Placing Oil Seal on Installation Tool 6635

(6) Position the seal and tool onto the crankshaft (Fig. 43).

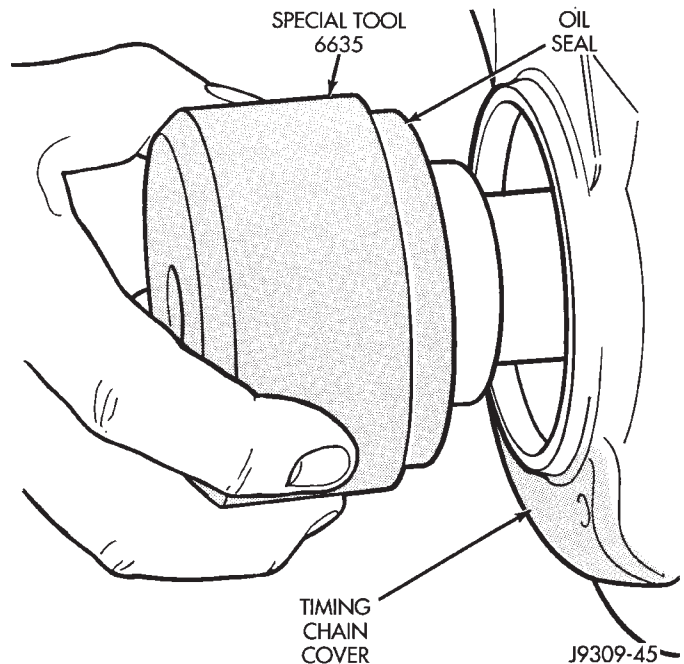


Fig. 43 Position Tool and Seal onto Crankshaft

(7) Using the vibration damper bolt, tighten the bolt to draw the seal into position on the crankshaft (Fig. 44).

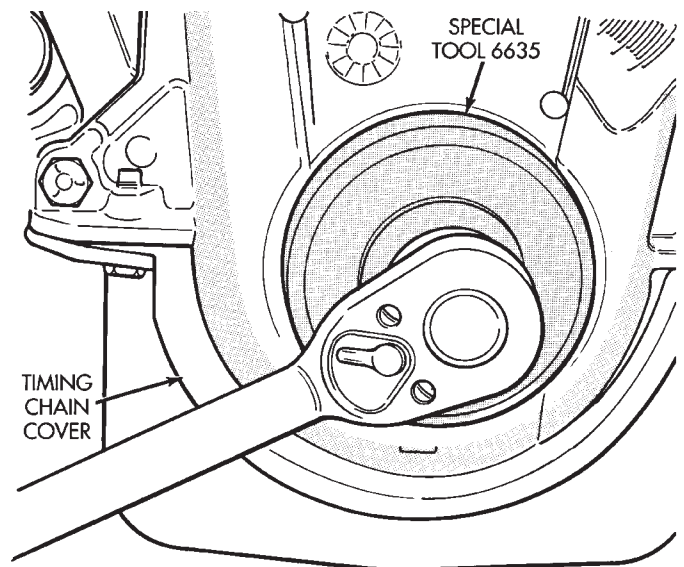


Fig. 44 Installing Oil Seal

(8) Remove the vibration damper bolt and seal installation tool.

(9) Inspect the seal flange on the vibration damper.

REMOVAL AND INSTALLATION (Continued)

- (10) Install the vibration damper.
- (11) Connect the negative cable to the battery.

CRANKSHAFT OIL SEALS — REAR

The service seal is a 2 piece, viton seal. The upper seal half can be installed with crankshaft removed from engine or with crankshaft installed. When a new upper seal is installed, install a new lower seal. The lower seal half can only be installed with the rear main bearing cap removed.

UPPER SEAL —CRANKSHAFT REMOVED**REMOVAL**

- (1) Remove the crankshaft. Discard the old upper seal.

INSTALLATION

- (1) Clean the cylinder block rear cap mating surface. Make sure the seal groove is free of debris.
- (2) Lightly oil the new upper seal lips with engine oil.
- (3) Install the new upper rear bearing oil seal with the white paint facing towards the rear of the engine.
- (4) Position the crankshaft into the cylinder block.
- (5) Lightly oil the new lower seal lips with engine oil.
- (6) Install the new lower rear bearing oil seal into the bearing cap with the white paint facing towards the rear of the engine.
- (7) Apply 5 mm (0.20 in) drop of Loctite 518, or equivalent, on each side of the rear main bearing cap (Fig. 45). DO NOT over apply sealant or allow the sealant to contact the rubber seal. Assemble bearing cap to cylinder block immediately after sealant application.

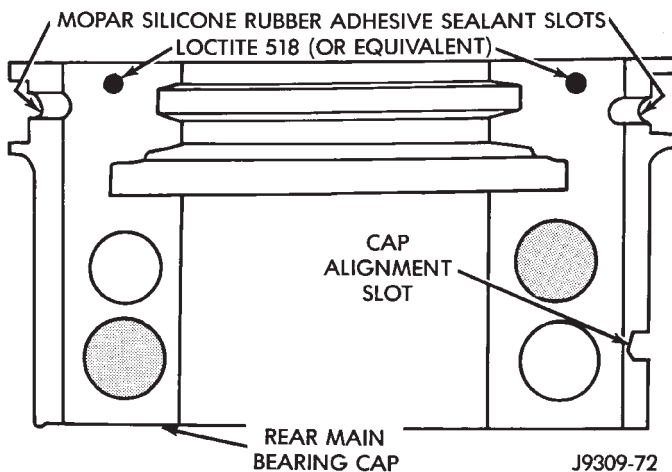


Fig. 45 Sealant Application to Bearing Cap

- (8) To align the bearing cap, use cap slot, alignment dowel and cap bolts. DO NOT remove excess

material after assembly. DO NOT strike rear cap more than 2 times for proper engagement.

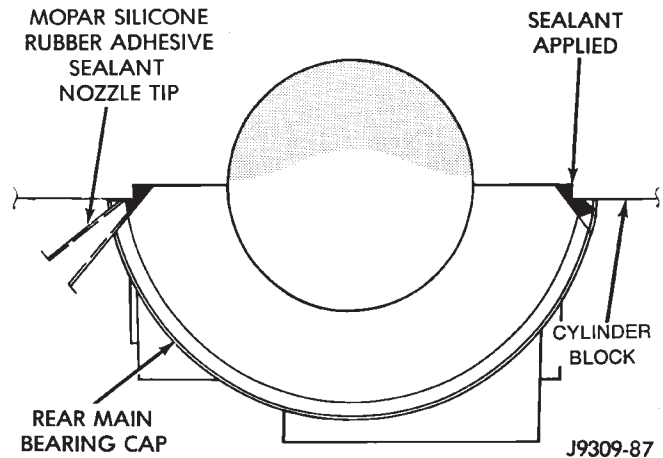
- (9) Clean and oil all cap bolts. Install all main bearing caps. Install all cap bolts and alternately tighten to 115 N-m (85 ft. lbs.) torque.

- (10) Install oil pump.

(11) Apply Mopar Silicone Rubber Adhesive Sealant, or equivalent, at bearing cap to block joint to provide cap to block and oil pan sealing (Fig. 46). Apply enough sealant until a small amount is squeezed out. Withdraw nozzle and wipe excess sealant off the oil pan seal groove.

- (12) Install new front crankshaft oil seal.

- (13) Immediately install the oil pan.



**Fig. 46 Apply Sealant to Bearing Cap to Block Joint
UPPER SEAL —CRANKSHAFT INSTALLED**

REMOVAL

- (1) Remove the oil pan.
- (2) Remove the oil pump from the rear main bearing cap.
- (3) Remove the rear main bearing cap. Remove and discard the old lower oil seal.
- (4) Carefully remove and discard the old upper oil seal.

INSTALLATION

(1) Clean the cylinder block mating surfaces before oil seal installation. Check for burr at the oil hole on the cylinder block mating surface to rear cap.

(2) Lightly oil the new upper seal lips with engine oil. To allow ease of installation of the seal, loosen at least the 2 main bearing caps forward of the rear bearing cap.

(3) Rotate the new upper seal into the cylinder block being careful not to shave or cut the outer surface of the seal. To assure proper installation, use the installation tool provided with the kit. Install the new seal with the white paint facing towards the rear of the engine.

REMOVAL AND INSTALLATION (Continued)

(4) Install the new lower rear bearing oil seal into the bearing cap with the white paint facing towards the rear of the engine.

(5) Apply 5 mm (0.20 in) drop of Loctite 518, or equivalent, on each side of the rear main bearing cap (Fig. 45). DO NOT over apply sealant or allow the sealant to contact the rubber seal. Assemble bearing cap to cylinder block immediately after sealant application. Be sure the white paint faces toward the rear of the engine.

(6) To align the bearing cap, use cap slot, alignment dowel and cap bolts. DO NOT remove excess material after assembly. DO NOT strike rear cap more than 2 times for proper engagement.

(7) Install the rear main bearing cap with cleaned and oiled cap bolts. Alternately tighten ALL cap bolts to 115 N·m (85 ft. lbs.) torque.

(8) Install oil pump.

(9) Apply Mopar Silicone Rubber Adhesive Sealant, or equivalent, at bearing cap to block joint to provide cap to block and oil pan sealing (Fig. 46). Apply enough sealant until a small amount is squeezed out. Withdraw nozzle and wipe excess sealant off the oil pan seal groove.

(10) Immediately install the oil pan.

LOWER SEAL

REMOVAL

(1) Remove the oil pan.

(2) Remove the oil pump from the rear main bearing cap.

(3) Remove the rear main bearing cap and discard the old lower seal.

INSTALLATION

(1) Clean the rear main cap mating surfaces including the oil pan gasket groove.

(2) Carefully install a new upper seal (refer to Upper Seal Replacement - Crankshaft Installed procedure above).

(3) Lightly oil the new lower seal lips with engine oil.

(4) Install a new lower seal in bearing cap with the white paint facing the rear of engine.

(5) Apply 5 mm (0.20 in) drop of Loctite 518, or equivalent, on each side of the rear main bearing cap (Fig. 45). DO NOT over apply sealant or allow the sealant to contact the rubber seal. Assemble bearing cap to cylinder block immediately after sealant application.

(6) To align the bearing cap, use cap slot, alignment dowel and cap bolts. DO NOT remove excess material after assembly. DO NOT strike rear cap more than 2 times for proper engagement.

(7) Install the rear main bearing cap with cleaned and oiled cap bolts. Alternately tighten the cap bolts to 115 N·m (85 ft. lbs.) torque.

(8) Install oil pump.

(9) Apply Mopar Silicone Rubber Adhesive Sealant, or equivalent, at bearing cap to block joint to provide cap to block and oil pan sealing (Fig. 46). Apply enough sealant until a small amount is squeezed out. Withdraw nozzle and wipe excess sealant off the oil pan seal groove.

(10) Immediately install the oil pan.

ENGINE CORE OIL AND CAMSHAFT PLUGS

Engine core plugs have been pressed into the oil galleries behind the camshaft thrust plate (Fig. 47). This will reduce internal leakage and help maintain higher oil pressure at idle.

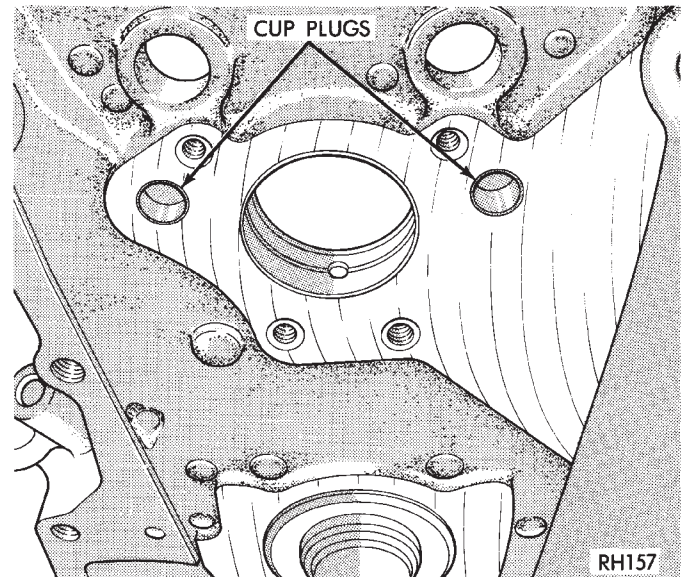


Fig. 47 Location of Cup Plugs in Oil Galleries

REMOVAL

(1) Using a blunt tool such as a drift or a screwdriver and a hammer, strike the bottom edge of the cup plug (Fig. 48).

(2) With the cup plug rotated, grasp firmly with pliers or other suitable tool and remove plug (Fig. 48).

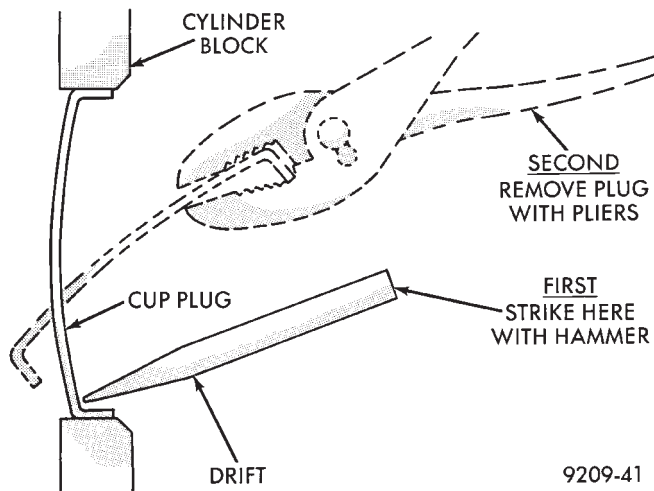
INSTALLATION

Thoroughly clean inside of cup plug hole in cylinder block or head. Be sure to remove old sealer.

Be certain the new plug is cleaned of all oil or grease.

(1) Coat edges of plug and core hole with Mopar Gasket Maker, or equivalent.

CAUTION: DO NOT drive cup plug into the casting, as restricted coolant flow can result and cause serious engine problems.

REMOVAL AND INSTALLATION (Continued)**Fig. 48 Core Hole Plug Removal**

(2) Using proper plug drive, drive cup plug into hole. The sharp edge of the plug should be at least 0.50 mm (0.020 in.) inside the lead-in chamfer.

(3) It is not necessary to wait for curing of the sealant. The cooling system can be filled and the vehicle placed in service immediately.

DISASSEMBLY AND ASSEMBLY**HYDRAULIC TAPPETS**

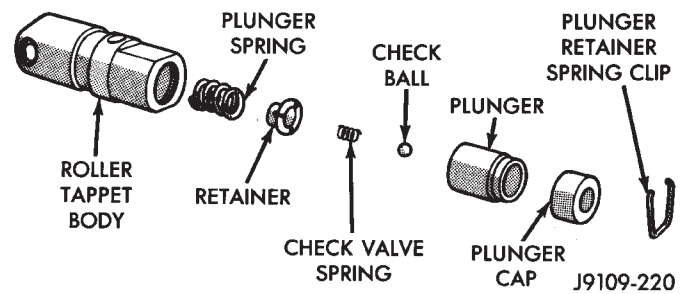
CAUTION: The plunger and tappet bodies are not interchangeable. The plunger and valve must always be fitted to the original body. It is advisable to work on one tappet at a time to avoid mixing of parts. Mixed parts are not compatible. **DO NOT** disassemble a tappet on a dirty work bench.

DISASSEMBLE

- (1) Pry out plunger retainer spring clip (Fig. 49).
- (2) Clean varnish deposits from inside of tappet body above plunger cap.
- (3) Invert tappet body and remove plunger cap, plunger, check valve, check valve spring, check valve retainer and plunger spring (Fig. 49). Check valve could be flat or ball.

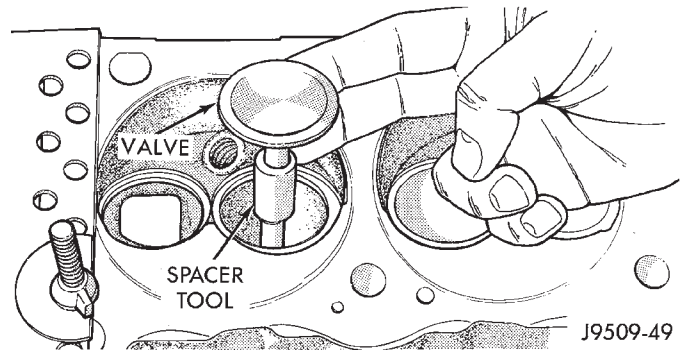
ASSEMBLE

- (1) Clean all tappet parts in a solvent that will remove all varnish and carbon.
- (2) Replace tappets that are unfit for further service with new assemblies.
- (3) If plunger shows signs of scoring or wear, install a new tappet assembly. If valve is pitted, or valve seat on end of plunger is prevented from seating, install a new tappet assembly.
- (4) Assemble tappets (Fig. 49).

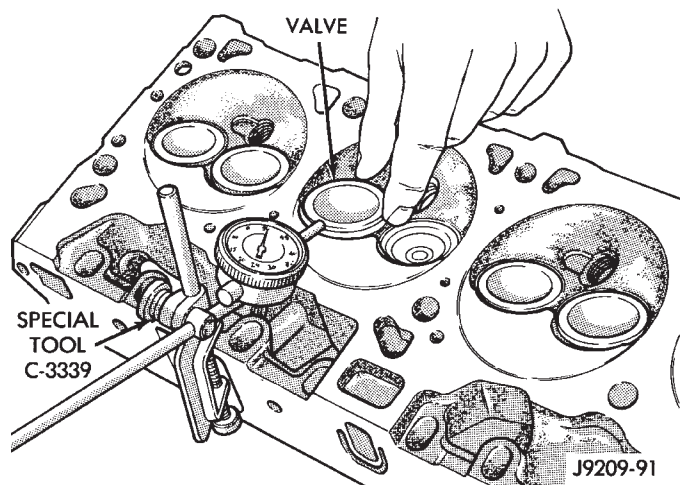
**Fig. 49 Hydraulic Tappet Assembly****VALVE SERVICE****VALVE GUIDES**

Measure valve stem guide clearance as follows:

- (1) Install Valve Guide Sleeve Tool C-3973 over valve stem and install valve (Fig. 50). The special sleeve places the valve at the correct height for checking with a dial indicator.

**Fig. 50 Positioning Valve with Tool C-3973**

- (2) Attach Dial Indicator Tool C-3339 to cylinder head and set it at right angle of valve stem being measured (Fig. 51).

**Fig. 51 Measuring Valve Guide Wear**

- (3) Move valve to and from the indicator. The total dial indicator reading should not exceed 0.432 mm (0.017 inch). Ream the guides for valves with over-

DISASSEMBLY AND ASSEMBLY (Continued)

size stems if dial indicator reading is excessive or if the stems are scuffed or scored.

(4) Service valves with oversize stems are available (Fig. 52).

Reamer O/S	Valve Guide Size
0.076 mm (0.003 in.)	8.026 – 8.052 mm (0.316 – 0.317 in.)
0.381 mm (0.015 in.)	8.331 – 8.357 mm (0.328 – 0.329 in.)

J9309-30

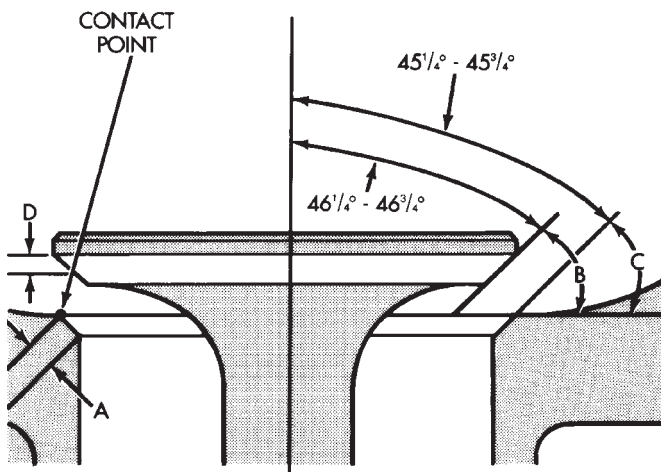
Fig. 52 Reamer Sizes

(5) Slowly turn reamer by hand and clean guide thoroughly before installing new valve. **Ream the valve guides from standard to 0.381 mm (0.015 inch).** Use a 2 step procedure so the valve guides are reamed true in relation to the valve seat:

- Step 1—Ream to 0.0763 mm (0.003 inch).
- Step 2—Ream to 0.381 mm (0.015 inch).

REFACING VALVES AND VALVE SEATS

The intake and exhaust valves have a $43\text{-}1/4^\circ$ to $43\text{-}3/4^\circ$ face angle and a $44\text{-}1/4^\circ$ to $44\text{-}3/4^\circ$ seat angle (Fig. 53).



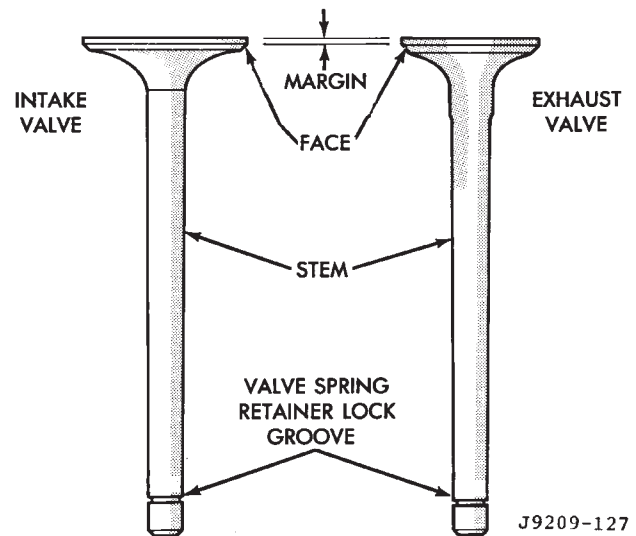
- A - SEAT WIDTH - INTAKE 1.016 – 1.524 mm (0.040 – 0.060 in.)
EXHAUST 1.524 – 2.032 mm (0.060 – 0.080 in.)
B - FACE ANGLE (INTAKE & EXHAUST) $43\text{-}1/4^\circ$ – $43\text{-}3/4^\circ$
C - SEAT ANGLE (INTAKE & EXHAUST) $44\text{-}1/4^\circ$ – $44\text{-}3/4^\circ$
D - CONTACT SURFACE

J9309-95

Fig. 53 Valve Face and Seat Angles

VALVES

Inspect the remaining margin after the valves are refaced (Fig. 54). Valves with less than 1.190 mm (0.047 inch) margin should be discarded.



J9209-127

Fig. 54 Intake and Exhaust Valves

VALVE SEATS

CAUTION: DO NOT un-shroud valves during valve seat refacing (Fig. 55).

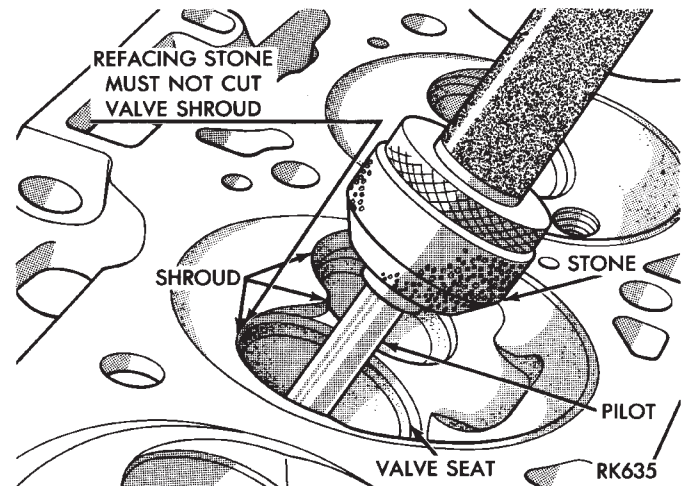


Fig. 55 Refacing Valve Seats

(1) When refacing valve seats, it is important that the correct size valve guide pilot be used for reseating stones. A true and complete surface must be obtained.

(2) Measure the concentricity of valve seat using a dial indicator. Total runout should not exceed 0.051 mm (0.002 inch) total indicator reading.

(3) Inspect the valve seat with Prussian blue to determine where the valve contacts the seat. To do this, coat valve seat **LIGHTLY** with Prussian blue then set valve in place. Rotate the valve with light

DISASSEMBLY AND ASSEMBLY (Continued)

pressure. If the blue is transferred to the center of valve face, contact is satisfactory. If the blue is transferred to the top edge of valve face, lower valve seat with a 15° stone. If the blue is transferred to bottom edge of valve face raise valve seat with a 60° stone.

(4) When seat is properly positioned the width of intake seats should be 1.016-1.524 mm (0.040-0.060 inch). The width of the exhaust seats should be 1.524-2.032 mm (0.060-0.080 inch).

VALVE SPRING INSPECTION

Whenever valves have been removed for inspection, reconditioning or replacement, valve springs should be tested. As an example the compression length of the spring to be tested is 1-5/16 inch. Turn table of Universals Valve Spring Tester Tool until surface is in line with the 1-5/16 inch mark on the threaded stud. Be sure the zero mark is to the front (Fig. 56). Place spring over stud on the table and lift compressing lever to set tone device. Pull on torque wrench until ping is heard. Take reading on torque wrench at this instant. Multiply this reading by 2. This will give the spring load at test length. Fractional measurements are indicated on the table for finer adjustments. Refer to specifications to obtain specified height and allowable tensions. Discard the springs that do not meet specifications.

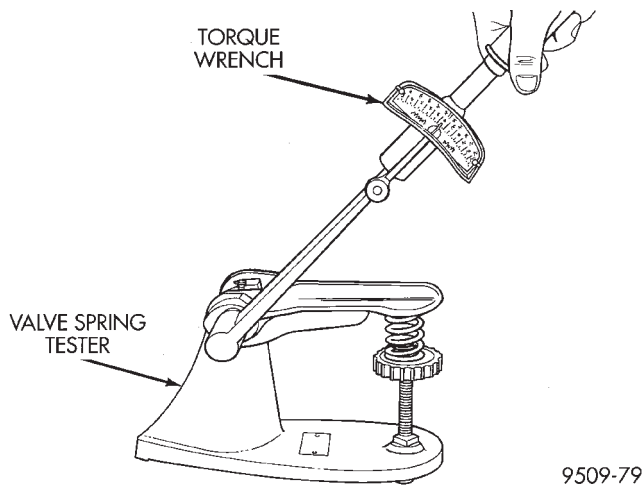


Fig. 56 Testing Valve Spring for Compressed Length

OIL PUMP**DISASSEMBLE**

- (1) Remove the relief valve as follows:
 - (a) Remove cotter pin. Drill a 3.175 mm (1/8 inch) hole into the relief valve retainer cap and insert a self-threading sheet metal screw.
 - (b) Clamp screw into a vise and while supporting oil pump, remove cap by tapping pump body using a soft hammer. Discard retainer cap and remove spring and relief valve (Fig. 57).

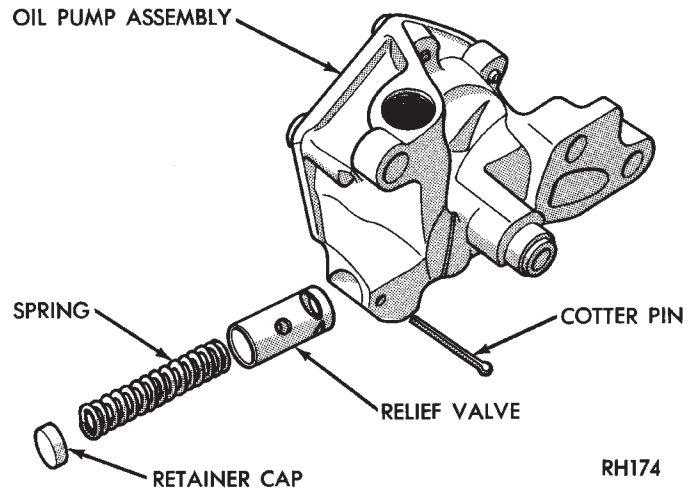


Fig. 57 Oil Pressure Relief Valve

- (2) Remove oil pump cover (Fig. 58).
- (3) Remove pump outer rotor and inner rotor with shaft (Fig. 58).
- (4) Wash all parts in a suitable solvent and inspect carefully for damage or wear.

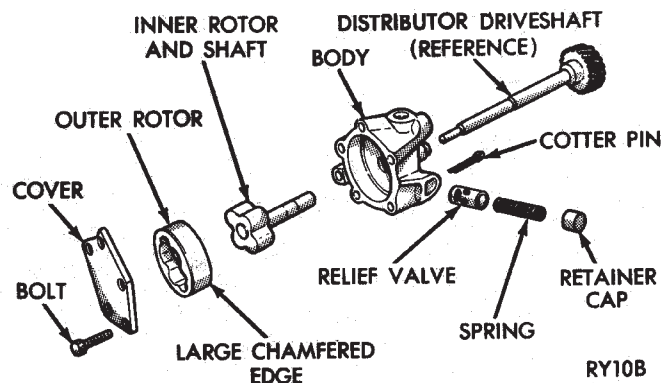


Fig. 58 Oil Pump

ASSEMBLE

- (1) Install pump rotors and shaft, using new parts as required.
- (2) Position the oil pump cover onto the pump body. Tighten cover bolts to 11 N·m (95 in. lbs.) torque.
- (3) Install the relief valve and spring. Insert the cotter pin.
- (4) Tap on a new retainer cap.
- (5) Prime oil pump before installation by filling rotor cavity with engine oil.

CYLINDER BLOCK**DISASSEMBLE**

- Engine assembly removed from vehicle:
- (1) Remove the cylinder head.
 - (2) Remove the oil pan.

DISASSEMBLY AND ASSEMBLY (Continued)

(3) Remove the piston and connecting rod assemblies.

ASSEMBLE

- (1) Install the piston and connecting rod assembly.
- (2) Install the oil pan.
- (3) Install the cylinder head.
- (4) Install the engine into the vehicle.

CLEANING AND INSPECTION

CYLINDER HEADS

CLEANING

Clean all surfaces of cylinder block and cylinder heads.

Clean cylinder block front and rear gasket surfaces using a suitable solvent.

INSPECTION

Inspect all surfaces with a straightedge if there is any reason to suspect leakage. If out-of-flatness exceeds 0.00075 mm/mm (0.00075 inch/inch) times the span length in inches in any direction, either replace head or lightly machine the head surface.

FOR EXAMPLE: A 305 mm (12 inch) span is 0.102 mm (0.004 inch) out-of-flat. The allowable out-of-flat is 305×0.00075 (12 x 0.00075) equals 0.23 mm (0.009 inch). This amount of out-of-flat is acceptable.

The cylinder head surface finish should be 1.78-3.00 microns (70-125 micro inches).

Inspect push rods. Replace worn or bent rods.

PISTON AND CONNECTING ROD ASSEMBLY

INSPECTION

Check the crankshaft connecting rod journal for excessive wear, taper and scoring.

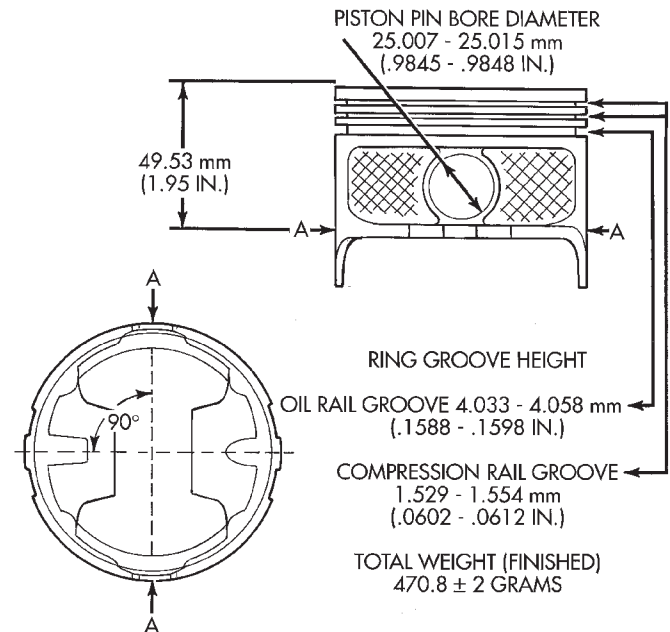
Check the cylinder block bore for out-of-round, taper, scoring and scuffing.

Check the pistons for taper and elliptical shape before they are fitted into the cylinder bore (Fig. 59).

CRANKSHAFT JOURNALS

The crankshaft connecting rod and main journals should be checked for excessive wear, taper and scoring. The maximum taper or out-of-round on any crankshaft journal is 0.025 mm (0.001 inch).

Journal grinding should not exceed 0.305 mm (0.012 inch) under the standard journal diameter. **DO NOT** grind thrust faces of No.3 main bearing. **DO NOT** nick crank pin or bearing fillets. After grinding, remove rough edges from crankshaft oil holes and clean out all oil passages.



PISTON SIZE	A DIA = PISTON DIAMETER		BORE DIAMETER	
	MIN. mm (IN.)	MAX. mm (IN.)	MIN. mm (IN.)	MAX. mm (IN.)
A				
B	101.580 (3.9992)	101.592 (3.9997)	101.605 (4.0002)	101.618 (4.0007)
C	101.592 (3.9997)	101.605 (4.0002)	101.618 (4.0007)	101.630 (4.0012)
D	101.605 (4.0002)	101.618 (4.0007)	101.630 (4.0012)	101.643 (4.0017)
E				

J9509-79

Fig. 59 Piston Measurements—5.9L

CAUTION: After any journal grind, it is important that the final paper or cloth polish be in the same direction as the engine rotates.

OIL PAN

CLEANING

Clean the block and pan gasket surfaces.

Trim or remove excess sealant film in the rear main cap oil pan gasket groove. **DO NOT remove the sealant inside the rear main cap slots.**

If present, trim excess sealant from inside the engine.

Clean oil pan in solvent and wipe dry with a clean cloth.

Clean oil screen and pipe thoroughly in clean solvent. Inspect condition of screen.

INSPECTION

Inspect oil drain plug and plug hole for stripped or damaged threads. Repair as necessary.

Inspect oil pan mounting flange for bends or distortion. Straighten flange, if necessary.

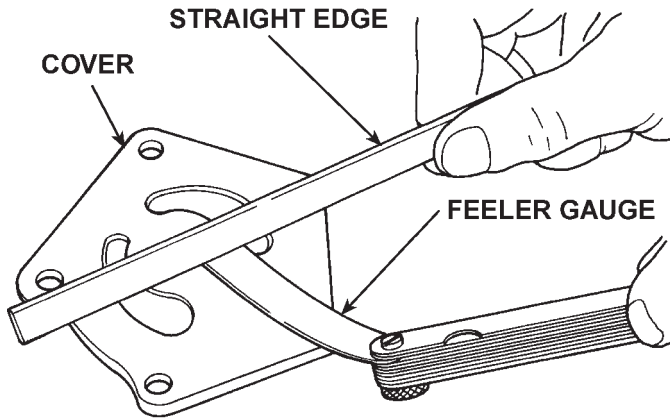
CLEANING AND INSPECTION (Continued)

OIL PUMP

INSPECTION

Mating surface of the oil pump cover should be smooth. Replace pump assembly if cover is scratched or grooved.

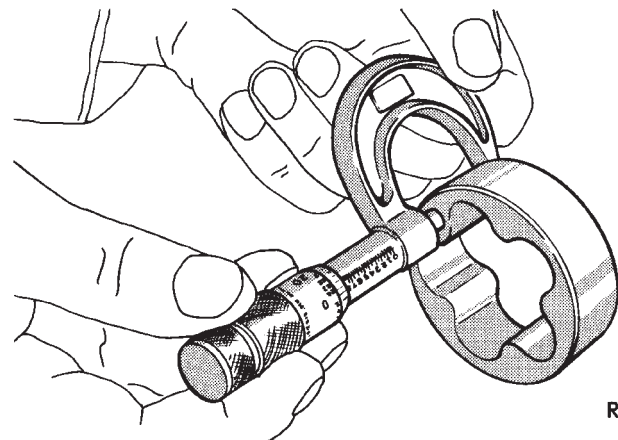
Lay a straightedge across the pump cover surface (Fig. 60). If a 0.038 mm (0.0015 inch) feeler gauge can be inserted between cover and straightedge, pump assembly should be replaced.



8020cd6e

Fig. 60 Checking Oil Pump Cover Flatness

Measure thickness and diameter of OUTER rotor. If outer rotor thickness measures 20.9 mm (0.825 inch) or less or if the diameter is 62.7 mm (2.469 inches) or less, replace outer rotor (Fig. 61).



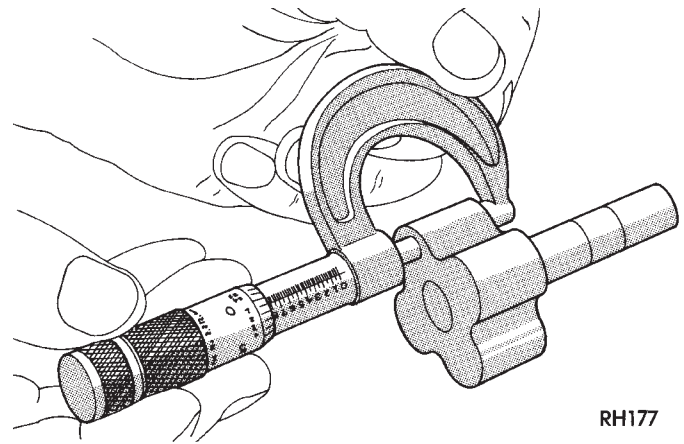
RH176

Fig. 61 Measuring Outer Rotor Thickness

If inner rotor measures 20.9 mm (0.825 inch) or less, replace inner rotor and shaft assembly (Fig. 62).

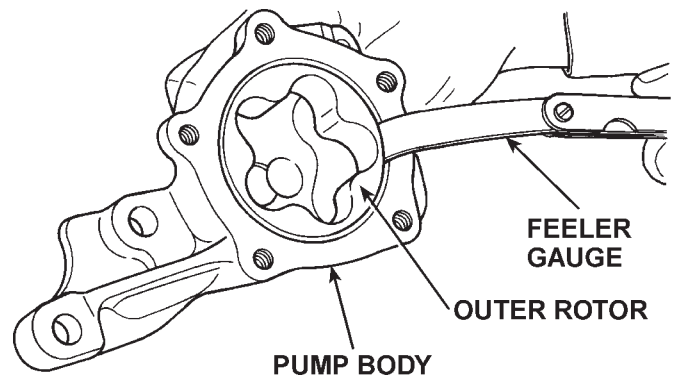
Slide outer rotor into pump body. Press rotor to the side with your fingers and measure clearance between rotor and pump body (Fig. 63). If clearance is 0.356 mm (0.014 inch) or more, replace oil pump assembly.

Install inner rotor and shaft into pump body. If clearance between inner and outer rotors is 0.203



RH177

Fig. 62 Measuring Inner Rotor Thickness

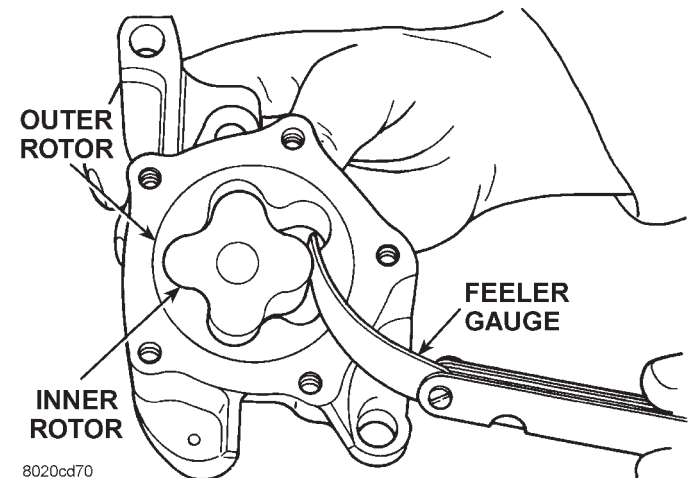


8020cd6f

Fig. 63 Measuring Outer Rotor Clearance in Housing

mm (0.008 inch) or more, replace shaft and both rotors (Fig. 64).

Place a straightedge across the face of the pump, between bolt holes. If a feeler gauge of 0.102 mm (0.004 inch) or more can be inserted between rotors and the straightedge, replace pump assembly (Fig. 65).

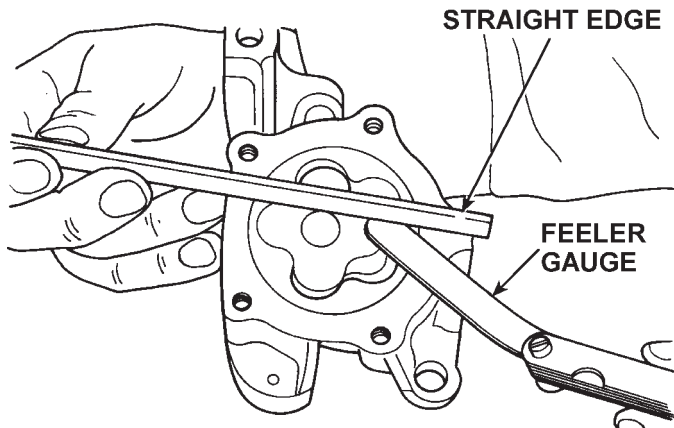


8020cd70

Fig. 64 Measuring Clearance Between Rotors

CLEANING AND INSPECTION (Continued)

Inspect oil pressure relief valve plunger for scoring and free operation in its bore. Small marks may be removed with 400-grit wet or dry sandpaper.



8020cd71

Fig. 65 Measuring Clearance Over Rotors

The relief valve spring has a free length of approximately 49.5 mm (1.95 inches). The spring should test between 19.5 and 20.5 pounds when compressed to 34 mm (1-11/32 inches). Replace spring that fails to meet these specifications (Fig. 66).

If oil pressure was low and pump is within specifications, inspect for worn engine bearings or other reasons for oil pressure loss.

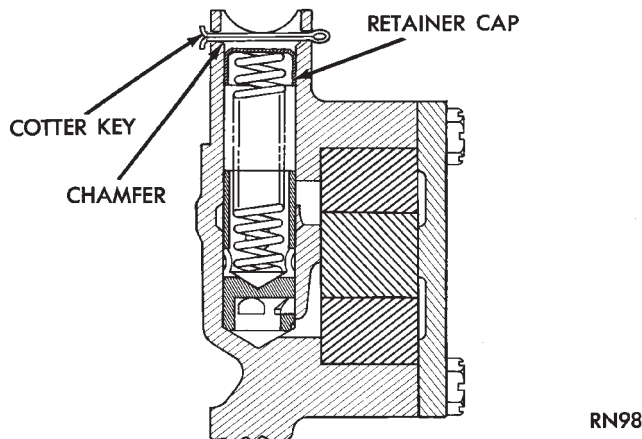


Fig. 66 Proper Installation of Retainer Cap

CYLINDER BLOCK

CLEANING

Clean cylinder block thoroughly and check all core hole plugs for evidence of leaking.

INSPECTION

Examine block for cracks or fractures.

The cylinder walls should be checked for out-of-round and taper with Cylinder Bore Indicator Tool C-119. The cylinder block should be bored and honed with new pistons and rings fitted if:

- The cylinder bores show more than 0.127 mm (0.005 in.) out-of-round.
- The cylinder bores show a taper of more than 0.254 mm (0.010 in.).
- The cylinder walls are badly scuffed or scored.

Boring and honing operation should be closely coordinated with the fitting of pistons and rings, so that specified clearances can be maintained.

OIL LINE PLUG

The oil line plug is located in the vertical passage at the rear of the block between the oil-to-filter and oil-from-filter passages (Fig. 67). Improper installation or plug missing could cause erratic, low, or no oil pressure.

The oil plug must come out the bottom. Use flat dowel, down the oil pressure sending unit hole from the top, to remove oil plug.

(1) Remove oil pressure sending unit from back of block.

(2) Insert a 3.175 mm (1/8 in.) finish wire, or equivalent, into passage.

(3) Plug should be 190.0 to 195.2 mm (7-1/2 to 7-11/16 in.) from machined surface of block (Fig. 67). If plug is too high, use a suitable flat dowel to position properly.

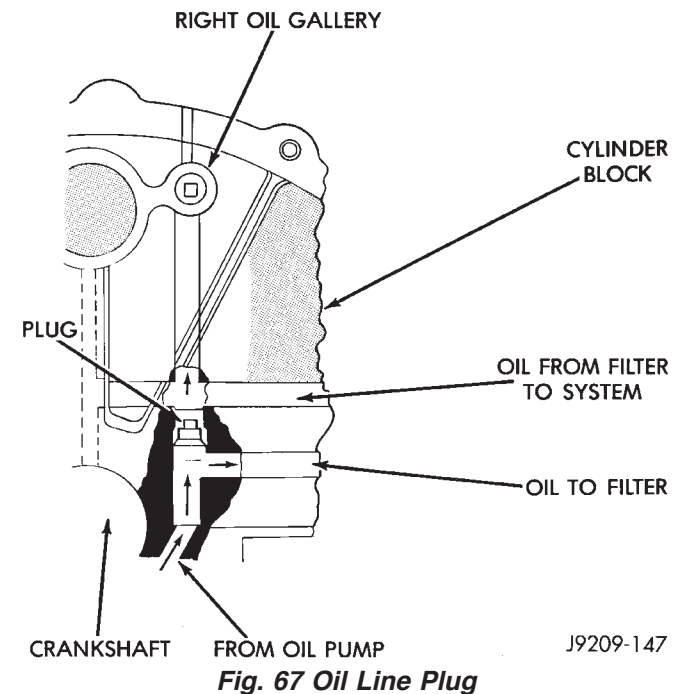


Fig. 67 Oil Line Plug

(4) If plug is too low, remove oil pan and No. 4 main bearing cap. Use suitable flat dowel to position properly. Coat outside diameter of plug with Mopar Stud and Bearing Mount Adhesive, or equivalent. Plug should be 54.0 to 57.7 mm (2-1/8 to 2-5/16 in.) from bottom of the block.

SPECIFICATIONS

5.9L ENGINE SPECIFICATIONS

GENERAL INFORMATION

Engine Type 90° V-8 OHV
 Bore and Stroke . . . 101.6 x 90.9 mm (4.00 x 3.58 in.)
 Displacement 5.9L (360 c.i.)
 Compression Ratio 9.1:1
 Firing Order 1-8-4-3-6-5-7-2
 Lubrication Pressure Feed – Full Flow Filtration
 Cooling System . . . Liquid Cooled – Forced Circulation
 Cylinder Block Cast Iron
 Cylinder Head Cast Iron
 Crankshaft Nodular Iron
 Camshaft Nodular Cast Iron
 Combustion Chambers . . . Wedge - High Swirl Valve
 Shrouding
 Pistons Aluminum Alloy w/strut
 Connecting Rods Forged Steel
 Compression Pressure . . . 689.5 kPa (100 psi) (Min.)

CAMSHAFT

Bearing Diameter

No. 1 50.800 – 50.825 mm (2.000 – 2.001 in.)
 No. 2 50.394 – 50.419 mm (1.984 – 1.985 in.)
 No. 3 50.013 – 50.038 mm (1.969 – 1.970 in.)
 No. 4 49.606 – 49.632 mm (1.953 – 1.954 in.)
 No. 5 39.688 – 39.713 mm (1.5625 – 1.5635 in.)

Bearing Journal Diameter

No. 1 50.749 – 50.775 mm (1.998 – 1.999 in.)
 No. 2 50.343 – 50.368 mm (1.982 – 1.983 in.)
 No. 3 49.962 – 49.987 mm (1.967 – 1.968 in.)
 No. 4 49.555 – 49.581 mm (1.951 – 1.952 in.)
 No. 5 39.637 – 39.662 mm (1.5605 – 1.5615 in.)

Bearing to Journal Clearance

Standard 0.0254 – 0.0762 mm (0.001 – 0.003 in.)
 Service Limit 0.127 mm (0.005 in.)

Camshaft End Play

End Play 0.051 – 0.254 mm (0.002 – 0.010 in.)

CONNECTING RODS

Piston Pin bore Diameter 24.966 – 24.978 mm
 (0.9829 – 0.9834 in.)
 Side Clearance 0.152 – 0.356 mm
 (0.006 – 0.014 in.)

CRANKSHAFT

Rod Journal

Diameter 53.950 – 53.975 mm (2.124 – 2.125 in.)
 Out of Round (Max.) 0.0254 mm (0.001 in.)
 Taper (Max.) 0.0254 mm (0.001 in.)

Rod Journal

Bearing Clearance 0.013 – 0.056 mm
 (0.0005 – 0.0022 in.)

Service Limit 0.0762 mm (0.003 in.)

Main Bearing Journal

Diameter . . . 71.361 – 71.387 mm (2.8095 – 2.8105 in.)

Out of Round (Max.) 0.127 mm (0.001 in.)

Taper (Max.) 0.0254 mm (0.001 in.)

Bearing Clearance (#1 Journal) . . . 0.013 – 0.038 mm
 (0.0005 – 0.0015 in.)

Service Limit (#1 Journal) 0.0381 mm
 (0.0015 in.)

Bearing Clearance (#2-5 Journals) . . . 0.013 – 0.051 mm
 (0.0005 – 0.002 in.)

Service Limit (#2-5 Journals) 0.064 mm
 (0.0025 in.)

Crankshaft End Play

End Play 0.051 – 0.178 mm (0.002 – 0.007 in.)

Service Limit 0.254 mm (0.010 in.)

CYLINDER BLOCK

Cylinder Bore

Diameter . . . 101.60 – 101.65 mm (4.000 – 4.002 in.)

Out of Round (Max.) 0.127 mm (0.005 in.)

Taper (Max.) 0.254 mm (0.010 in.)

Lifter Bore

Diameter . . . 22.99 – 23.01 mm (0.9051 – 0.9059 in.)

Distributor Drive Bushing (Press Fit)

Bushing to Bore Interference . . . 0.0127 – 0.3556 mm
 (0.0005 – 0.0140 in.)

Shaft to Bushing Clearance . . . 0.0178 – 0.0686 mm
 (0.0007 – 0.0027 in.)

CYLINDER HEAD AND VALVES

Valve Seat

Angle 44.25° – 44.75°

Runout (Max.) 0.0762 mm (0.003 in.)

Width (Finish) – Intake 1.016 – 1.524 mm
 (0.040 – 0.060 in.)

Width (Finish) – Exhaust 1.524 – 2.032 mm
 (0.060 – 0.080 in.)

Valves

Face Angle 43.25° – 43.75°

Head Diameter – Intake 47.752 mm (1.88 in.)

Head Diameter – Exhaust 41.072 (1.617 in.)

Length (Overall) – Intake 126.21 – 126.85 mm
 (4.969 – 4.994 in.)

Length (Overall) – Exhaust 126.44 – 127.30 mm
 (4.978 – 5.012 in.)

SPECIFICATIONS (Continued)

Valve Seat

Lift (@ zero lash) – Intake10.414 mm (0.410 in.)
 Lift (@ zero lash) – Exhaust . . .10.592 mm (0.417 in.)
 Stem Diameter – Intake9.449 – 9.474 mm
 (0.372 – 0.373 in.)
 Stem Diameter – Exhaust9.423 – 9.449 mm
 (0.371 – 0.372 in.)
 Guide Bore9.500 – 9.525 mm (0.374 – 0.375 in.)
 Stem to Guide Clearance –
 Intake . . .0.0254 – 0.0762 mm (0.001 – 0.003 in.)
 Stem to Guide Clearance –
 Exhaust . . .0.0508 – 0.1016 mm (0.002 – 0.004 in.)
 Service Limit0.4318 (0.017 in.)

Valve Springs

Free Length49.962 mm (1.967 in.)
 Spring Tension – (valve closed) . .378 N @ 41.66 mm
 (85 lbs. @ 1.64 in.)
 Spring Tension – (valve open) . . .890 N @ 30.89 mm
 (200 lbs. @ 1.212 in.)
 Number of Coils6.8
 Installed Height41.66 mm (1.64 in.)
 Wire Diameter4.50 mm (0.177 in.)

HYDRAULIC TAPPETS

Body Diameter22.949 – 22.962 mm
 (0.9035 – 0.9040 in.)
 Clearance (to bore)0.0279 – 0.0610 mm
 (0.0011 – 0.0024 in.)
 Dry Lash1.524 – 5.334 mm (0.060 – 0.210 in.)
 Push Rod Length175.64 – 176.15 mm
 (6.915 – 6.935 in.)

OIL PRESSURE

Curb Idle (Min.*)41.4 kPa (6 psi)
 3000 rpm207 – 552 kPa (30 – 80 psi)
 Oil Pressure Bypass Valve Setting62 – 103 kPa
 (9 – 15 psi)
 Switch Actuating Pressure34.5 – 48.3 kPa
 (5 – 7 psi)

CAUTION: If oil pressure is zero at curb idle, DO NOT RUN ENGINE.

OIL PUMP

Clearance over Rotors (Max.) . .0.1016 mm (0.004 in.)
 Cover Out of Flat (Max.) . . .0.0381 mm (0.0015 in.)
 Inner Rotor Thickness (Min.) . . .20.955 mm (0.825 in.)
 Outer Rotor Clearance (Max.) . . .0.3556 mm (0.014 in.)
 Outer Rotor Diameter (Min.) . . .62.7126 mm (2.469 in.)
 Outer Rotor Thickness (Min.) . . .20.955 mm (0.825 in.)
 Tip Clearance between Rotors (Max.) . . .0.2032 mm
 (0.008 in.)

PISTONS

Clearance at Top of Skirt0.013 – 0.038 mm
 (0.0005 – 0.0015 in.)
 Land Clearance (Diam.)0.508 – 0.660 mm
 (0.020 – 0.026 in.)
 Piston Length81.03 mm (3.19 in.)
 Piston Ring Groove Depth – #1&2 . . .4.761 – 4.912 mm
 (0.187 – 0.193 in.)
 Piston Ring Groove Depth – #3 . . .3.996 – 4.177 mm
 (0.157 – 0.164 in.)
 Weight582 – 586 grams (20.53 – 20.67 oz.)

PISTON PINS

Clearance in Piston0.006 – 0.019 mm
 (0.00023 – 0.00074 in.)
 Diameter25.007 – 25.015 mm (0.9845 – 0.9848 in.)
 End PlayNONE
 Length67.8 – 68.3 mm (2.67 – 2.69 in.)

PISTON RINGS

Ring Gap

Compression Ring (Top)0.30 – 0.55 mm
 (0.012 – 0.022 in.)
 Compression Ring (2nd)0.55 – 0.80 mm
 (0.022 – 0.031 in.)
 Oil Control (Steel Rails)0.381 – 1.397 mm
 (0.015 – 0.055 in.)

Ring Side Clearance

Compression Rings0.040 – 0.085 mm
 (0.0016 – 0.0033 in.)
 Oil Ring (Steel Rails)0.05 – 0.21 mm
 (0.002 – 0.008 in.)

Ring Width

Compression rings1.530 – 1.555 mm
 (0.060 – 0.061 in.)
 Oil Ring (Steel Rails) – Max.0.447 – 0.473 mm
 (0.018 – 0.019 in.)

VALVE TIMING

Exhaust Valve

Closes (ATDC)33°
 Opens (BBDC)56°
 Duration269°

Intake Valve

Closes (ATDC)62°
 Opens (BBDC)7°
 Duration249°
 Valve Overlap41°

SPECIFICATIONS (Continued)

OVERSIZE AND UNDERSIZE ENGINE COMPONENT MARKINGS

CONDITION	IDENTIFICATION	LOCATION OF IDENTIFICATION
0.025 mm (0.001 inch) U/S Crankshaft	R or M M-2-3 etc. (Indicating No. 2 & 3 main bearing journal) and/or R-1-4 etc. (Indicating No. 1 & 4 connecting rod journal)	Milled flat on number three crankshaft counterweight
0.508 mm (0.020 inch) O/S Cylinder Bores	A	Following engine serial number.
0.203 mm (0.008 inch) O/S Tappets	◆	3/8" diamond-shaped stamp Top pad — Front of engine and flat ground on outside surface of each O/S tappet bore.
0.127 mm (0.005 inch) O/S Valve Stems	X	Milled pad adjacent to two 3/8" tapped holes on each end of cylinder head.

J9209-120

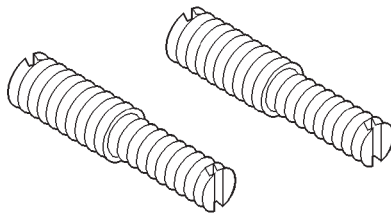
5.9L TORQUE SPECIFICATIONS

DESCRIPTION	TORQUE
Camshaft Sprocket	
Bolt68 N·m (50 ft. lbs.)
Camshaft Thrust Plate	
Bolts24 N·m (18 ft. lbs.)
Chain Case Cover	
Bolts41 N·m (30 ft. lbs.)
Connecting Rod Cap	
Bolts61 N·m (45 ft. lbs.)
Crankshaft Main Bearing Cap	
Bolts115 N·m (85 ft. lbs.)
Crankshaft Pulley	
Bolts24 N·m (210 in. lbs.)
Cylinder Head Bolts	
Step 1 – Initial68 N·m (50 ft. lbs.)
Step 2 – Final143 N·m (105 ft. lbs.)
Cylinder Head Cover	
Bolts11 N·m (95 in. lbs.)
Exhaust Manifold to Cylinder Head	
Bolts/Nuts34 N·m (25 ft. lbs.)
Flywheel	
Bolts75 N·m (55 ft. lbs.)
Front Engine Mount Bracket to Block	
Bolts81 N·m (60 ft. lbs.)
Front Engine Mount	
Through Bolt/Nut68 N·m (50 ft. lbs.)
Generator Mounting	
Bolts41 N·m (30 ft. lbs.)
Intake Manifold	
Bolts	Refer to procedure in this section

DESCRIPTION	TORQUE
Oil Pan	
Bolts24 N·m (215 in. lbs.)
Oil Pan Drain Plug	
Plug34 N·m (25 ft. lbs.)
Oil Pump	
Bolts41 N·m (30 ft. lbs.)
Oil Pump Cover	
Bolts11 N·m (95 in. lbs.)
Rear Mount Insulator to Support Bracket	
Nuts47 N·m (35 ft. lbs.)
Rear Mount Insulator to Crossmember	
Nut47 N·m (35 ft. lbs.)
Rear Support Bracket to Transmission	
Bolts102 N·m (75 ft. lbs.)
Rocker Arm	
Bolts28 N·m (21 ft. lbs.)
Spark Plugs	
Plugs41 N·m (30 ft. lbs.)
Starter Mounting	
Bolts68 N·m (50 ft. lbs.)
Thermostat Housing	
Bolts25 N·m (225 in. lbs.)
Throttle Body	
Bolts23 N·m (200 in. lbs.)
Torque Converter Drive Plate	
Bolts31 N·m (270 in. lbs.)
Transmission Support Bracket	
Bolts102 N·m (75 ft. lbs.)
Transmission Support Spacer to Insulator Mounting Plate – (4wd)	
Nuts204 N·m (150 ft. lbs.)

SPECIFICATIONS (Continued)

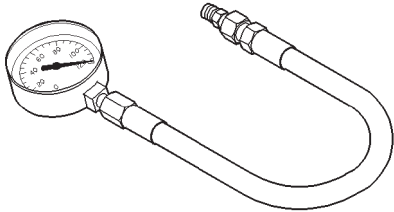
DESCRIPTION	TORQUE
Vibration Damper	
Bolt	183 N·m (135 ft. lbs.)
Water Pump to Chain Case Cover	
Bolt	41 N·m (30 ft. lbs.)



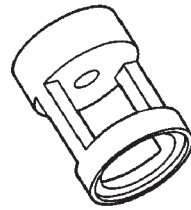
SPECIAL TOOLS

5.9L ENGINE

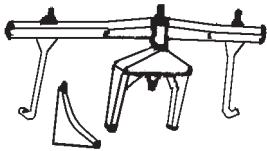
Adaptor 6633



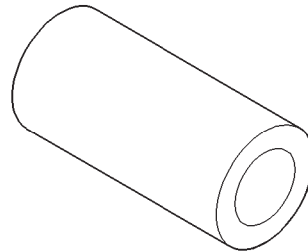
Oil Pressure Gauge C-3292



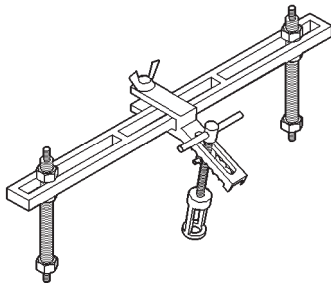
Adaptor 6716A



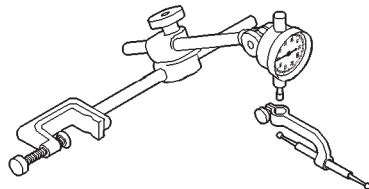
Engine Support Fixture C-3487-A



Valve Guide Sleeve C-3973



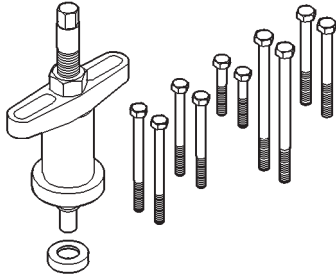
Valve Spring Compressor MD-998772-A



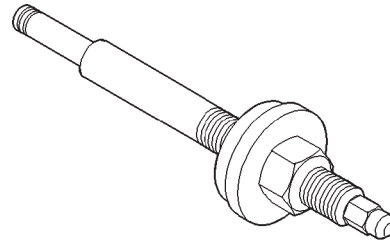
8011d42b

Dial Indicator C-3339

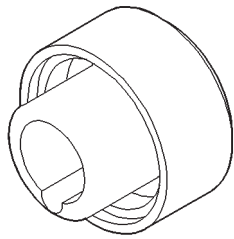
SPECIAL TOOLS (Continued)



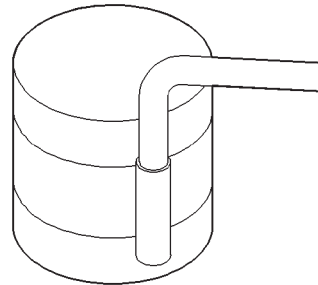
Puller C-3688



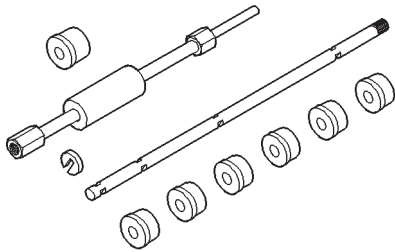
Distributor Bushing Driver/Burnisher C-3053



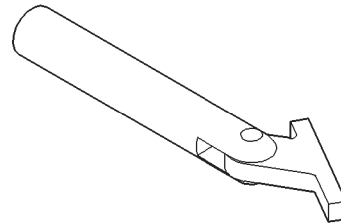
Front Oil Seal Installer 6635



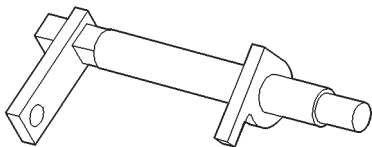
Piston Ring Compressor C-385



Cam Bearing Remover/Installer C-3132-A

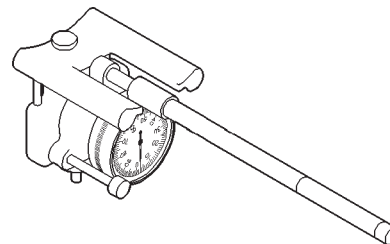


Crankshaft Main Bearing Remover C-3059



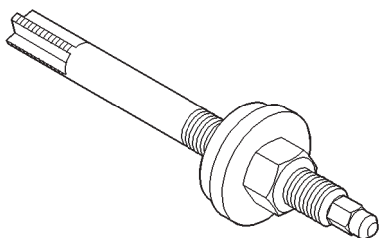
c-3509-8011d343

Camshaft Holder C-3509



8011c91a

Cylinder Bore Gauge C-119



Distributor Bushing Puller C-3052

ENGINE

CONTENTS

	page		page
GENERAL INFORMATION		OIL PAN	27
ENGINE IDENTIFICATION	1	OIL PUMP PRESSURE RELIEF VALVE	28
HYDRAULIC TAPPETS	1	OIL PUMP	28
DIAGNOSIS AND TESTING		PISTONS AND CONNECTING	
SERVICE DIAGNOSIS—		ROD ASSEMBLY	30
DIESEL—MECHANICAL	9	ROCKER ARMS AND PUSH RODS	19
SERVICE DIAGNOSIS—		TIMING CASE COVER OIL SEAL	25
DIESEL—PERFORMANCE	3	TIMING CASE COVER	25
TAPPET NOISE	12	VALVE SPRINGS	19
SERVICE PROCEDURES		VIBRATION DAMPER	24
VALVE SERVICE	12	DISASSEMBLY AND ASSEMBLY	
REMOVAL AND INSTALLATION		HYDRAULIC TAPPETS	37
CAMSHAFT BEARINGS	27	CLEANING AND INSPECTION	
CAMSHAFT	26	CYLINDER HEAD	37
CRANKSHAFT MAIN BEARINGS	34	CYLINDER WALL LINER ASSEMBLY	39
CYLINDER HEAD COVER	17	OIL PUMP	40
CYLINDER WALL LINER ASSEMBLY	32	PISTONS AND CONNECTING	
ENGINE ASSEMBLY	15	ROD ASSEMBLY	38
ENGINE CYLINDER HEAD	20	ROCKER ARMS AND PUSH RODS	37
ENGINE MOUNTS—FRONT	14	SPECIFICATIONS	
ENGINE MOUNT—REAR	14	ENGINE SPECIFICATIONS	41
HYDRAULIC TAPPETS	18	TORQUE SPECIFICATIONS	43
INTERNAL VACUUM PUMP	28	SPECIAL TOOLS	
OIL FILTER ADAPTER	29	SPECIAL TOOLS	44

GENERAL INFORMATION

ENGINE IDENTIFICATION

The engine model code (3-digit number/letter code) and serial number are stamped on the forward facing side of the engine block (Fig. 1).

HYDRAULIC TAPPETS

Before disassembling any part of the engine to correct tappet noise, check the oil pressure. If vehicle has no oil pressure gauge, install a reliable gauge at the pressure sending unit. The pressure should be between 4 bars (50 psi) at 3000 RPM.

Check the oil level after the engine reaches normal operating temperature. Allow 5 minutes to stabilize oil level, check dipstick. The oil level in the pan should never be above the FULL mark or below the ADD OIL mark on dipstick. Either of these 2 conditions could be responsible for noisy tappets:

OIL LEVEL HIGH

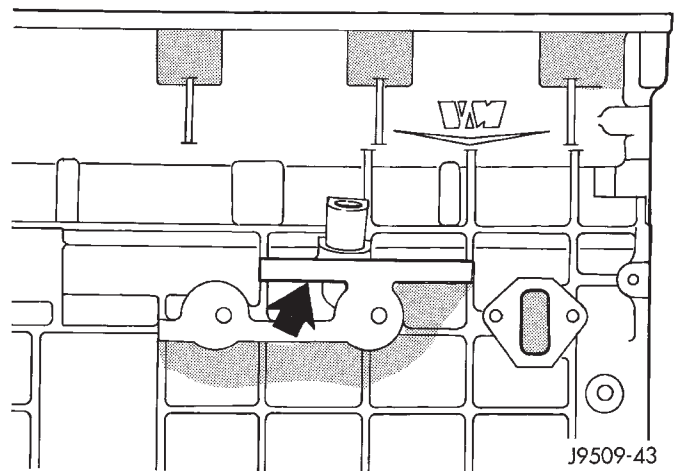


Fig. 1 Engine Code Location

If oil level is above the FULL mark, it is possible for the connecting rods to dip into the oil. With the

GENERAL INFORMATION (Continued)

Displacement	2.5L (2499 cc)
Bore	92.00
Stroke	94.00
Compression Ratio	20.95:1
Vacuum at idle	600 mm/Hg (23.6 In/Hg)
Belt Tension	53 DaN - New 30 DaN - Used
Thermostat Opening	80°C ± 2°C
Generator Rating	Bosch 50/120 Amp
Cooling System Capacity	9.5 Liter
P/S Capacity	0.75 Liter
Engine Oil Capacity	6.8 Liter w/filter change
Timing System	Pushrod operated overhead valves, with gear-driven camshaft in crankcase.
Air Intake	Dry filter.
Fuel Feed	Vane pump incorporated in injection pump.
Fuel System	Indirect fuel injection (precombustion chamber).
Combustion Cycle	4 stroke.
Cooling System	Water cooling.
Injection Pump	Rotary pump with built-in mechanical regulator.
Lubrication	Pressure lubrication by rotary pump, full-flow filtration.
Engine Rotation	Clockwise viewed from front cover.

engine running, this condition could create foam in the oil pan. Foam in oil pan would be fed to the hydraulic tappets by the oil pump causing them to lose length and allow valves to seat noisily.

OIL LEVEL LOW

Low oil level may allow oil pump to take in air. When air is fed to the tappets, they lose length which allows valves to seat noisily. Any leaks on intake side of oil pump through which air can be drawn will create the same tappet action. Check the lubrication system from the intake strainer to the pump cover, including the relief valve retainer cap. When tappet noise is due to aeration, it may be intermittent or constant, and usually more than 1 tappet will be noisy. When oil level and leaks have been corrected, operate the engine at fast idle. Run engine for a sufficient time to allow all of the air inside the tappets to be bled out.

J9509-174

Engine Description

DIAGNOSIS AND TESTING**SERVICE DIAGNOSIS—DIESEL—PERFORMANCE**

CONDITION	POSSIBLE CAUSES	CORRECTION
ENGINE WILL NOT CRANK OR CRANKS SLOWLY	<ol style="list-style-type: none"> 1. Starting motor operating, but not cranking the engine. 2. Crankshaft rotation restricted. 3. Starting circuit connections loose or corroded. 4. Neutral safety switch or starter relay inoperative. 5. Battery charge low. 6. No voltage to starter solenoid. 7. Solenoid or starter motor inoperative. 	<ol style="list-style-type: none"> 1. Remove the starter motor. Check for broken flywheel teeth or a broken starting motor spring. 2. Rotate the engine to check for rotational resistance. 3. Clean and tighten connections. 4. Check starter relay supply voltage and proper operation of neutral safety switch (if equipped). Replace defective parts. 5. Check battery voltage. Replace battery if a charge cannot be held. 6. Check voltage to solenoid. If necessary, replace the solenoid. 7. Replace starter motor.
ENGINE CRANKS, BUT WILL NOT START NO SMOKE	<ol style="list-style-type: none"> 1. No fuel in supply tank. 2. Electrical fuel shutdown solenoid not operating. 3. Air intake or exhaust plugged. 4. Fuel filter plugged. 5. Excessive fuel inlet restriction. 6. Injection pump not getting fuel or fuel is aerated. 7. One or more injectors worn or not operating properly. 8. Worn or inoperative injection pump. 9. Camshaft out of time. 	<ol style="list-style-type: none"> 1. Fill fuel supply. 2. Check for loose wires and verify that the fuel shutdown solenoid and fuel shutdown solenoid relay is functioning. 3. Remove the obstruction. 4. Drain fuel/water separator and replace fuel filter. 5. Check fuel inlet restriction. Correct cause. 6. Check fuel flow/bleed fuel system. 7. Check/replace bad or improperly operating injectors. 8. Visually check delivery with externally connected injector to one of the pump outlets. Repair or replace the pump if fuel is not being delivered. 9. Check/correct gear train timing alignment.
ENGINE HARD TO START, OR WILL NOT START SMOKE FROM EXHAUST	<ol style="list-style-type: none"> 1. Incorrect starting procedure. 2. Cranking speed too slow. 3. Cylinder heads heater plugs relay defective. 4. One or more cylinder head heater plugs defective. 5. Insufficient intake air. 	<ol style="list-style-type: none"> 1. The fuel shutoff solenoid control must be in the run position. Ensure proper procedure is being used. 2. (A) Verify that the transmission is not engaged. (B) Check the battery, starting motor and look for loose or corroded wiring connections. 3. Verify system is working. Repair/replace inoperative parts. 4. Verify system is working. Repair/replace inoperative parts. 5. Inspect or replace filter and check for obstruction to the air supply tube.

DIAGNOSIS AND TESTING (Continued)

CONDITION	POSSIBLE CAUSES	CORRECTION
ENGINE HARD TO START, OR WILL NOT START SMOKE FROM EXHAUST (CONT.)	<ul style="list-style-type: none"> 6. Air in fuel system or the fuel supply is inadequate. 7. Contaminated fuel. 8. Fuel screen plugged. 9. One or more injectors worn or not operating properly. 10. Worn or inoperative injection pump. 11. Injection pump out of time. 12. Engine compression low. 	<ul style="list-style-type: none"> 6. Check the flow through the filter and bleed the system. Locate and eliminate the air source. 7. Verify by operating the engine with clean fuel from a temporary tank. Check for presence of gasoline. Drain and flush fuel supply tank. Replace fuel/water separator filter. 8. Check fuel screen. 9. Check/replace improperly operating injectors. 10. Visually check fuel delivery with an externally connected injector to one of the pump outlets. Repair or replace the pump if fuel is not being delivered. 11. Check/Time the pump (refer to Group 14, Fuel System). 12. Check compression to identify the problem.
ENGINE STARTS, BUT WILL NOT KEEP RUNNING	<ul style="list-style-type: none"> 1. Cylinder heads heater plugs relay defective. 2. One or more cylinder head heater plugs defective. 3. Intake air or exhaust system restricted. 4. Air in the fuel system or the fuel supply is inadequate. 5. Fuel waxing due to extremely cold weather. 6. Contaminated fuel. 	<ul style="list-style-type: none"> 1. Verify system is working. Repair/replace inoperative parts. 2. Verify system is working. Repair/replace inoperative parts. 3. Visually check for exhaust restriction and inspect the air intake. Repair/replace restricting parts. 4. Check flow through the filter and bleed the system. Locate and eliminate the air source. 5. Verify by inspecting the fuel filter. Clean the system and use climatized fuel. Replace fuel/water separator filter. Check fuel heater for proper operation. 6. Verify by operating the engine with clean fuel from a temporary supply tank. Check for presence of gasoline. Replace fuel/water separator filter.
SURGING (SPEED CHANGE)	<ul style="list-style-type: none"> 1. If the condition occurs at idle, the idle speed is set too low for the accessories. 2. High pressure fuel leak. 3. One or more injectors worn or not operating properly. 4. Improperly operating injection pump. 	<ul style="list-style-type: none"> 1. Adjust the idle speed. 2. Inspect/correct leaks in the high pressure lines. Fittings and delivery valve sealing washers. 3. Check/replace the inoperative injectors. 4. Replace the injector pump.

DIAGNOSIS AND TESTING (Continued)

CONDITION	POSSIBLE CAUSES	CORRECTION
<p>ROUGH IDLE (IRREGULARLY FIRING OR ENGINE SHAKING)</p>	<ol style="list-style-type: none"> 1. If engine is cold, glow plug relay on glow plug(s) defective. 2. Engine mounts damaged or lose. 3. High pressure fuel leaks. 4. Air in the fuel system. 5. Sticking needle valve in an injector. 	<ol style="list-style-type: none"> 1. Refer to troubleshooting for cylinder head heater plugs (see Group 14, Fuel System). 2. Repair or replace mounts. 3. Correct leaks in the high pressure lines, fittings or delivery valves. 4. Bleed the fuel system and eliminate the source of the air. 5. Check and replace the injector with the sticking needle valve.
<p>ENGINE RUNS ROUGH</p>	<ol style="list-style-type: none"> 1. Fuel injection lines leaking. 2. Air in the fuel or the fuel supply is inadequate. 3. Contaminated fuel. 4. Incorrect valve operation. 5. Injection pump timing incorrect. 6. Improperly operating injectors. 7. Defective injection pump (delivery valve). 8. Camshaft out of time. 9. Damaged camshaft or tappets. 10. Automatic timing advance not operating. 	<ol style="list-style-type: none"> 1. Correct leaks in the high pressure lines, fittings, injectors sealing washers or delivery valves. 2. Check the flow through the filter and bleed the system. Locate and eliminate the air source. 3. Verify by operating the engine with clean fuel from a temporary supply tank. Check for presence of gasoline. Replace fuel/water separator filter. 4. Check for a bent push rod and adjust valves. Replace push rod, if necessary. 5. Check/time pump (refer to Group 14, Fuel System). 6. Replace inoperative injectors. 7. Repair or replace injection pump. 8. Check/correct gear train timing alignment. 9. Inspect camshaft valve lift. Replace camshaft and tappets. 10. Check injection pump. Check fuel injector sensor at number 1 cylinder injector.
<p>ENGINE RPM WILL NOT REACH RATED SPEED</p>	<ol style="list-style-type: none"> 1. Engine overload. 2. Improperly operating tachometer. 3. Inadequate fuel supply. 4. Air/fuel controls leak. 	<ol style="list-style-type: none"> 1. Verify high idle speed without load. Investigate operation to be sure correct gear is being used. 2. Verify engine speed with hand tachometer, correct as required. 3. Check the fuel flow through the system to locate the reason for inadequate fuel supply, correct as required. 4. Check and repair leak. Check AFC tubing for obstruction.

DIAGNOSIS AND TESTING (Continued)

CONDITION	POSSIBLE CAUSES	CORRECTION
ENGINE RPM WILL NOT REACH RATED SPEED (CONT.)	6. Improperly operating injection pump.	6. Repair or replace injection pump.
LOW POWER	<ol style="list-style-type: none"> 1. Fuel control lever not moving to full throttle. 2. High oil level. 3. Engine overloaded. 4. Slow throttle response caused by leaking or obstructed air control tube or improperly operating control in the pump. 5. Inadequate intake air flow. 6. Inadequate fuel supply. Air in the fuel. 7. Excessive exhaust restriction. 8. High fuel temperature. 9. Poor quality fuel or fuel contaminated with gasoline. 10. Air leak between the turbocharger and the intake manifold. 11. Exhaust leak at the manifold or turbocharger. 12. Improperly operating turbocharger. 13. Wastegate operation. 14. Valve not operating. 15. Worn or improperly operating injectors. 16. Incorrect injection pump timing. 17. Improperly operating injection pump. 	<ol style="list-style-type: none"> 1. Check/correct for stop-to-stop travel. 2. Check/correct oil level. 3. Check for added loading from accessories or driven units, brakes dragging and other changes in vehicle loading. Repair/replace as needed. 4. Check for leaks and obstructions. Tighten the fittings. Repair or replace the pump if the controls are not functioning. 5. Inspect/replace air cleaner element. Look for other restrictions. 6. Check the flow through the filter to locate the source of the restriction. Check fuel pressure and inlet restriction. 7. Check/correct the restriction in the exhaust system. 8. Verify that fuel heater is off when engine is warm. Check for restricted fuel drain tubes. Repair/replace as needed. 9. Verify by operating from a temporary tank with good fuel. Check for presence of gasoline. Replace fuel/water separator filter. 10. Check/correct leaks in hoses, gaskets, charge air cooler and around mounting capscrews or through holes in the manifold cover. 11. Check/correct leaks in the manifold or turbocharger gaskets. If manifold is cracked, replace manifold. 12. Inspect/replace turbocharger. 13. Check wastegate operation. 14. Check for bent push rod, replace if necessary. 15. Check/replace injectors. 16. Verify injection pump timing (see Group 14, Fuel System). 17. Repair or replace injection pump.

DIAGNOSIS AND TESTING (Continued)

CONDITION	POSSIBLE CAUSES	CORRECTION
<p>EXCESSIVE EXHAUST SMOKE</p>	<ol style="list-style-type: none"> 1. Engine running too cold (white smoke). 2. Improper starting procedure (white smoke). 3. Fuel supply inadequate. 4. Injection pump timing. 5. Inadequate intake air. 6. Air leak between turbocharger and intake manifold. 7. Exhaust leak at the manifold or turbocharger. 8. Improperly operating turbocharger. 9. Improperly operating injectors. 10. Improperly operating or overfueled injector pump. 11. Piston rings not sealing (blue smoke). 	<ol style="list-style-type: none"> 1. Refer to troubleshooting for coolant temperature below normal (refer to Group 7, Cooling System). Inspect cylinder head heater plugs for proper operation. 2. Use proper starting procedures. 3. Check fuel supply pressure and inlet restriction. 4. Check and time pump (refer to Group 14, Fuel System). 5. Inspect/change air filter. Look for other restriction. Check charge air cooler for obstructions. 6. Check/correct leaks in the air crossover tube, hoses, gaskets, mounting capscrews or through holes in the manifold cover. 7. Check/correct leaks in the manifold or turbocharger gaskets. If cracked replace manifold. 8. Inspect/replace turbocharger. 9. Check and replace inoperative injectors. 10. Repair or replace injection pump. 11. Perform blow-by check. Correct as required.
<p>ENGINE WILL NOT SHUT-OFF</p>	<ol style="list-style-type: none"> 1. Fuel shutoff solenoid inoperative. 2. Engine running on fumes drawn into the air intake. 3. Fuel injection pump malfunction. 	<ol style="list-style-type: none"> 1. Check/replace fuel shutoff solenoid. 2. Check the air intake ducts for the source of fumes. WARNING: In case of engine runaway due to flammable fumes from gasoline spills or turbocharger oil leaks being sucked into the engine, shut off engine ignition switch first then use a CO2 fire extinguisher and direct the spray under the front bumper to remove oxygen supply. The engine air intake is on the passenger side behind the bumper. The fire extinguisher must be directed at this location for emergency shutdown conditions. 3. Repair or replace fuel injection pump.

DIAGNOSIS AND TESTING (Continued)

CONDITION	POSSIBLE CAUSES	CORRECTION
COOLANT TEMPERATURE ABOVE NORMAL	<ol style="list-style-type: none"> 1. Low coolant level. 2. Incorrect/improperly operating pressure cap. 3. Loose drive belt on water pump/fan. 4. Inadequate air flow to the radiator. 5. Radiator fins plugged. 6. Collapsed radiator hose. 7. Improperly operating temperature sensor/gauge. 8. Improperly operating, incorrect or no thermostat. 9. Air in the cooling system. 10. Inoperative water pump. 11. Incorrect injection pump timing. 12. Overfueled injection pump. 13. Plugged cooling passages in radiator, head, head gasket or block. 14. Engine overloaded. 	<ol style="list-style-type: none"> 1. Check coolant level. Add coolant, if necessary. Locate and correct the source of the coolant loss, (refer to Group 7, Cooling). 2. Replace cap with the correct rating for the system. 3. Check/replace belt or belt tensioner. 4. Check/repair radiator core, fan shroud and viscous fan drive as required. 5. Blow debris from fins. 6. Replace the hose. Check coolant tank cap operation, (refer to Group 7, Cooling Tanks). 7. Verify that the gauge and temperature sensor are accurate. Replace gauge/sensor, if bad. 8. Check and replace the thermostat. 9. (A) make sure the fill rate is not being exceeded and the correct vented thermostat is installed. (B) Check for loose hose clamps. Tighten if loose. (C) If aeration continued, check for a compression leak through the head gasket. 10. Check and replace the water pump. 11. Verify pump timing marks are aligned. Check/time the injector pump(refer to Group 14, Fuel System). 12. Repair or replace the injection pump. 13. Flush the system and fill with clean coolant. 14. Verify that the engine load rating is not being exceeded.
COOLANT TEMPERATURE BELOW NORMAL	<ol style="list-style-type: none"> 1. Too much air flow across the radiator. 2. Incorrect thermostat or contamination in thermostat. 3. Temperature sensor or gauge inoperative. 4. Coolant not flowing by temperature sensor. 	<ol style="list-style-type: none"> 1. Check/repair viscous fan drive as required. 2. Check and replace thermostat. 3. Verify that the gauge and sensor are accurate. If not, replace gauge/sensor. 4. Check and clean coolant passages.

DIAGNOSIS AND TESTING (Continued)**SERVICE DIAGNOSIS—DIESEL—MECHANICAL.**

CONDITION	POSSIBLE CAUSES	CORRECTION
LUBRICATING OIL PRESSURE LOW	<ol style="list-style-type: none"> 1. Low oil level. 2. Oil viscosity thin, diluted or wrong specification. 3. Improperly operating pressure switch/gauge. 4. Relief valve stuck open. 5. Plugged oil filter. 6. If cooler was replaced, shipping plugs left in cooler. 7. Worn oil pump. 8. Suction tube loose or seal leaking. 9. Loose main bearing cap. 10. Worn bearings or wrong bearings installed. 11. Oil jet under piston bad fit into main carrier. 	<ol style="list-style-type: none"> 1. (A) Check and fill with clean engine oil. (B) Check for a severe external oil leak that could reduce the pressure. 2. Verify the correct oil is being used. Check for oil dilution. Refer to Contaminated Lube Oil (Engine Diagnosis Mechanical). 3. Verify the pressure switch is functioning correctly. If not, replace switch/gauge. 4. Check/replace valve. 5. Change oil filter. Oil filter change interval may need to be revised. 6. Check/remove shipping plugs. 7. Check and replace oil pump. 8. Check and replace seal. 9. Check and install new bearing and tighten cap to proper torque. 10. Inspect and replace connecting rod or main bearings. Check and replace piston cooling nozzles. 11. Check oil jet position.
LUBRICATING OIL PRESSURE TOO HIGH	<ol style="list-style-type: none"> 1. Pressure switch/gauge not operating properly. 2. Engine running to cold. 3. Oil viscosity too thick. 4. Oil pressure relief valve stuck closed or binding. 	<ol style="list-style-type: none"> 1. Verify the pressure switch is functioning correctly. If not, replace switch/gauge. 2. Refer to Coolant Temperature Below Normal (Engine Diagnosis Performance). 3. Make sure the correct oil being used, (Refer to Group 0, Lubrication and Maintenance). 4. Check and replace valve.
LUBRICATING OIL LOSS	<ol style="list-style-type: none"> 1. External leaks. 2. Crankcase being overfilled. 3. Incorrect oil specification or viscosity. 4. Oil cooler leak. 5. High blow-by forcing oil out the breather. 	<ol style="list-style-type: none"> 1. Visually inspect for oil leaks. Repair as required. 2. Verify that the correct dipstick is being used. 3. (A) Make sure the correct oil is being used. (B) Look for reduced viscosity from dilution with fuel. (C) Review/reduce the oil change intervals. 4. Check and replace the oil cooler. 5. Check the breather tube area for signs of oil loss. Perform the required repairs.

DIAGNOSIS AND TESTING (Continued)

CONDITION	POSSIBLE CAUSES	CORRECTION
LUBRICATING OIL LOSS (CONT.)	<ol style="list-style-type: none"> 6. Turbocharger leaking oil to the air intake. 7. Piston rings not sealing (oil being consumed by the engine). 	<ol style="list-style-type: none"> 6. Inspect the air ducts for evidence of oil transfer. Repair as required. 7. Perform blow-by check. Repair as required.
COMPRESSION KNOCKS	<ol style="list-style-type: none"> 1. Air in the fuel system. 2. Poor quality fuel or water/gasoline contaminated fuel. 3. Engine overloaded. 4. Incorrect injection pump timing. 5. Improperly operating injectors. 	<ol style="list-style-type: none"> 1. Bleed the fuel system (refer to Group 14, Fuel System). 2. Verify by operating from a temporary tank with good fuel. Clean and flush the fuel supply tanks. Replace fuel/water separator. 3. Verify the engine load rating is not being exceeded. 4. Check and time injection pump (refer to Group 14, Fuel System). 5. Check and replace inoperative injectors.
EXCESSIVE VIBRATION	<ol style="list-style-type: none"> 1. Loose or broken engine mounts. 2. Damaged fan or improperly operating accessories. 3. Improperly operating vibration damper. 4. Improperly operating viscous fan drive. 5. Worn or damaged generator bearing. 6. Flywheel housing misaligned. 7. Loose or broken power component. 8. Worn or unbalanced driveline components. 	<ol style="list-style-type: none"> 1. Replace engine mounts. 2. Check and replace the vibrating components. 3. Inspect/replace the vibration damper. 4. Inspect/replace the fan drive. 5. Check/replace the generator. 6. Check/correct flywheel alignment. 7. Inspect the crankshaft and rods for damage that causes an unbalance. Repair/replace as required. 8. Check/repair driveline components.
EXCESSIVE ENGINE NOISES	<ol style="list-style-type: none"> 1. Drive belt squeal, insufficient tension or abnormally high loading. 2. Intake air or exhaust leaks. 3. Turbocharger noise. 4. Gear train noise. 5. Power function knock. 	<ol style="list-style-type: none"> 1. Check the automatic tensioner and inspect the drive belt. Make sure water pump, tensioner pulley, fan hub and generator turn freely. 2. Refer to Excessive Exhaust smoke (Engine Diagnosis Performance). 3. Check turbocharger impeller and turbine wheel for housing contact. Repair/replace as required. 4. Visually inspect and measure gear backlash. Replace gears as required. 5. Check/replace rod and main bearings.

DIAGNOSIS AND TESTING (Continued)

CONDITION	POSSIBLE CAUSES	CORRECTION
GENERATOR NOT CHARGING OR INSUFFICIENT CHARGING	1. Loose or corroded battery. 2. Generator belt slipping. 3. Generator pulley loose on shaft. 4. Improperly operating generator.	1. Clean/tighten battery connection. 2. Check/replace automatic belt tensioner. Check/replace and adjust belt. 3. Tighten pulley. 4. Check/replace generator.

DIAGNOSIS AND TESTING (Continued)

TAPPET NOISE

(1) To determine source of tappet noise, operate engine at idle with cylinder head covers removed.

(2) Feel each valve spring or rocker arm to detect noisy tappet. The noisy tappet will cause the affected spring and/or rocker arm to vibrate or feel rough in operation.

NOTE: Worn valve guides or cocked springs are sometimes mistaken for noisy tappets. If such is the case, noise may be dampened by applying side thrust on the valve spring. If noise is not appreciably reduced, it can be assumed the noise is in the tappet. Inspect the rocker arm push rod sockets and push rod ends for wear.

(3) Valve tappet noise ranges from light noise to a heavy click. A light noise is usually caused by excessive leak down around the unit plunger or by the plunger partially sticking in the tappet body cylinder. The tappet should be replaced. A heavy click is caused by a tappet check valve not seating or by foreign particles becoming wedged between the plunger and the tappet body. This will cause the plunger to stick in the down position. This heavy click will be accompanied by excessive clearance between the valve stem and rocker arm as valve closes. In either case, tappet assembly should be removed for inspection and cleaning.

The valve train generates a noise very much like a light tappet noise during normal operation. Care must be taken to ensure that tappets are making the noise. In general, if more than one tappet seems to be noisy, its probably not the tappets.

SERVICE PROCEDURES

VALVE SERVICE

This procedure is done with the engine cylinder head removed from the block.

DISASSEMBLY

(1) Remove the engine cylinder head from the cylinder block (refer to cylinder head removal in this section).

(2) Use Valve Spring Compressor Tool and compress each valve spring.

(3) Remove the valve locks, retainers, and springs.

(4) Use an Arkansas smooth stone or a jewelers file to remove any burrs on the top of the valve stem, especially around the groove for the locks.

(5) Remove the valves, and place them in a rack in the same order as removed.

VALVE CLEANING

(1) Clean all carbon deposits from the combustion chambers, valve ports, valve stems, valve stem guides and head.

(2) Clean all grime and gasket material from the engine cylinder head machined gasket surface.

INSPECTION

(1) Inspect for cracks in the combustion chambers and valve ports.

(2) Inspect for cracks on the exhaust seat.

(3) Inspect for cracks in the gasket surface at each coolant passage.

(4) Inspect valves for burned, cracked or warped heads.

(5) Inspect for scuffed or bent valve stems.

(6) Replace valves displaying any damage.

(7) Check valve spring height (Fig. 2).

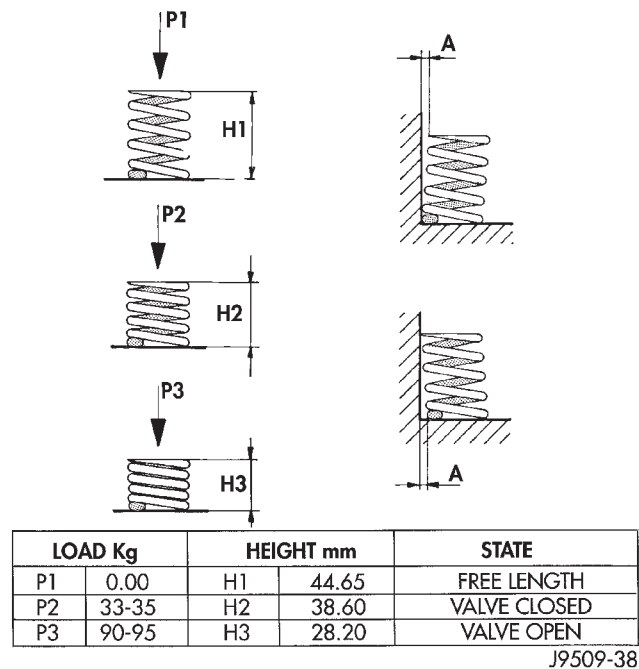


Fig. 2 Valve Spring Chart

VALVE REFACING

(1) Use a valve refacing machine to reface the intake and exhaust valves to the specified angle.

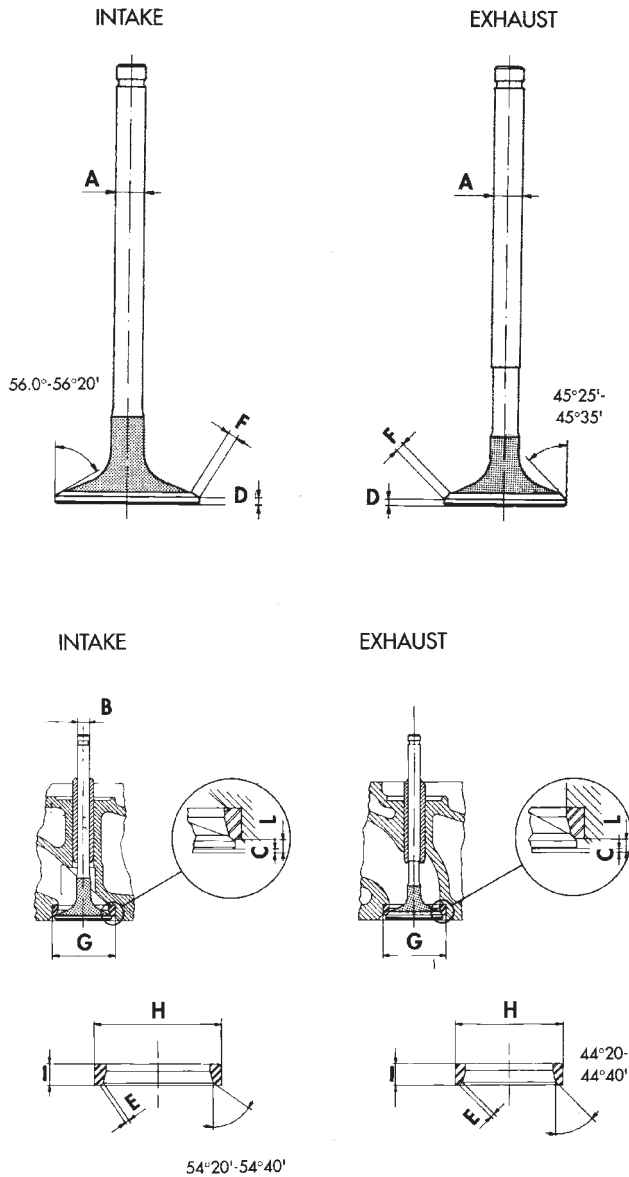
(2) After refacing, a margin of at least 4.52-4.49 mm (.178-.177 inch) must remain (Fig. 3). If the margin is less than 4.49 mm (.177 inch), the valve must be replaced.

VALVE SEAT REFACING

(1) Install a pilot of the correct size in the valve guide bore. Reface the valve seat to the specified angle with a good dressing stone. Remove only enough metal to provide a smooth finish.

(2) Use tapered stones to obtain the specified seat width when required.

SERVICE PROCEDURES (Continued)



MEASUREMENT	INTAKE	EXHAUST
A	7.940-7.960	7.922-7.940
B	8.00-8.015	8.000-8.015
C	0.880-1.140	0.990-1.250
D	2.2±0.08	2.09 ^{+0.07} / _{-0.06}
E	1.80-2.20	1.65-2.05
F	2.73-3.44	2.45-3.02
G	41.962-41.985	35.964-35.987
H	42.070-42.086	36.050-36.066
I	7.14-7.19	7.00-7.05
L	3.11-3.26	3.10-3.25

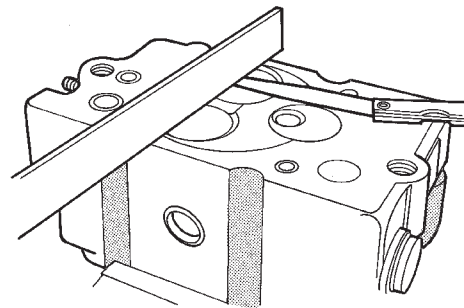
J9509-40

Fig. 3 Valve Specification

VALVE STAND DOWN

Valve stand down is to maintain the adequate compression ratio.

- (1) Invert cylinder head.
- (2) Fit each valve to its respective valve guide.
- (3) Using a straight edge and feeler gauge (Fig. 4), check valve head stand down: Inlet valve head stand down .80 to 1.2 mm (.031 to .047 in.) and exhaust valve stand down .79 to 1.19 mm (.031 to .047 in.).
- (4) If valve head stand down is not in accordance with above, discard original valves, check stand down with new valves and recut valve seat inserts to obtain correct stand down.

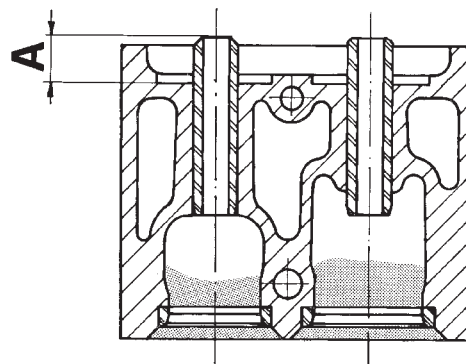


J9509-166

Fig. 4 Checking Valve Stand Down

VALVE GUIDES

- (1) Valve Guides height requirement.
- (2) Measurement A (Fig. 5): 13.50 - 14.00 mm.



J9509-36

Fig. 5 Valve Guide Height

VALVE STEM-TO-GUIDE CLEARANCE MEASUREMENT

- (1) Measure and record internal diameter of valve guides. Valve guide internal diameter is 8.0 to 8.015 mm (.3149 to .3155 ins.).
- (2) Measure valve stems and record diameters. Intake valve stem diameter 7.94 to 7.96 mm (.3125 to .3133 in). Exhaust valve stem diameter 7.92 to 7.94 mm (.3118 to .31215 in).

SERVICE PROCEDURES (Continued)

(3) Subtract diameter of valve stem from internal diameter of its respective valve guide to obtain valve stem clearance in valve guide. Clearance of inlet valve stem in valve guide is .040 to .075 mm (.0015 to .0029 in). Clearance of exhaust valve stem in valve guide is .060 to .095 mm (.0023 to .0037 in).

(4) If valve stem clearance in valve guide exceeds tolerances, new valve guides must be installed.

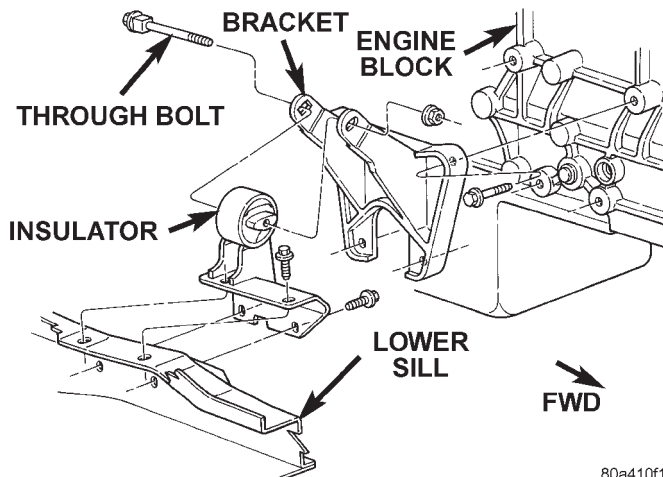
REMOVAL AND INSTALLATION

ENGINE MOUNTS—FRONT

The front mounts support the engine at each side. These supports are made of resilient rubber.

REMOVAL—RIGHT SIDE

- (1) Disconnect negative cable from battery.
- (2) Raise the vehicle.
- (3) Support the engine.
- (4) Remove through bolt nut. DO NOT remove the through bolt (Fig. 6).
- (5) Remove insulator sill plate bolts.
- (6) Remove engine mount bracket bolts.
- (7) Raise engine up.
- (8) Remove the through bolt.
- (9) Remove insulator.
- (10) Remove engine bracket.



80a410f1

Fig. 6 Front Mount—Right Side

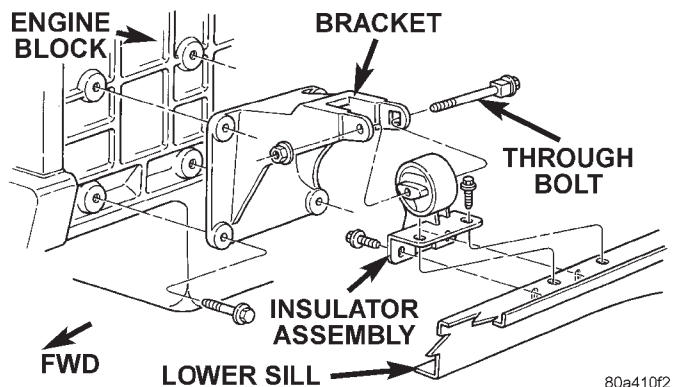
INSTALLATION—RIGHT SIDE

- (1) Install the engine support bracket and bolts, tighten bolts to 61 N·m (45 ft. lbs.).
- (2) Secure the insulator assembly on the lower sill. Tighten the bolts to 65 N·m (48 ft. lbs.).
- (3) Lower engine and place the insulator assembly into the bracket.
- (4) Install the through bolt nut. Tighten the through bolt nut to 65 N·m (48 ft. lbs.).
- (5) Remove the engine support.
- (6) Lower the vehicle.

- (7) Connect negative cable to battery

REMOVAL—LEFT SIDE

- (1) Disconnect negative cable from battery.
- (2) Raise the vehicle.
- (3) Support the engine.
- (4) Remove through bolt nut. DO NOT remove the through bolt (Fig. 7).
- (5) Remove insulator sill plate bolts.
- (6) Remove engine mount bracket bolts.
- (7) Raise engine up.
- (8) Remove the through bolt.
- (9) Remove insulator.
- (10) Remove engine bracket.



80a410f2

Fig. 7 Front Mount—Left Side

INSTALLATION—LEFT SIDE

- (1) Install the engine support bracket and bolts, tighten bolts to 61 N·m (45 ft. lbs.).
- (2) Secure the insulator assembly on the lower sill. Tighten the bolts to 65 N·m (48 ft. lbs.).
- (3) Lower engine and place the insulator assembly into the bracket.
- (4) Install the through bolt nut. Tighten the through bolt nut to 65 N·m (48 ft. lbs.).
- (5) Remove the engine support.
- (6) Lower the vehicle.
- (7) Connect negative cable to battery.

ENGINE MOUNT—REAR

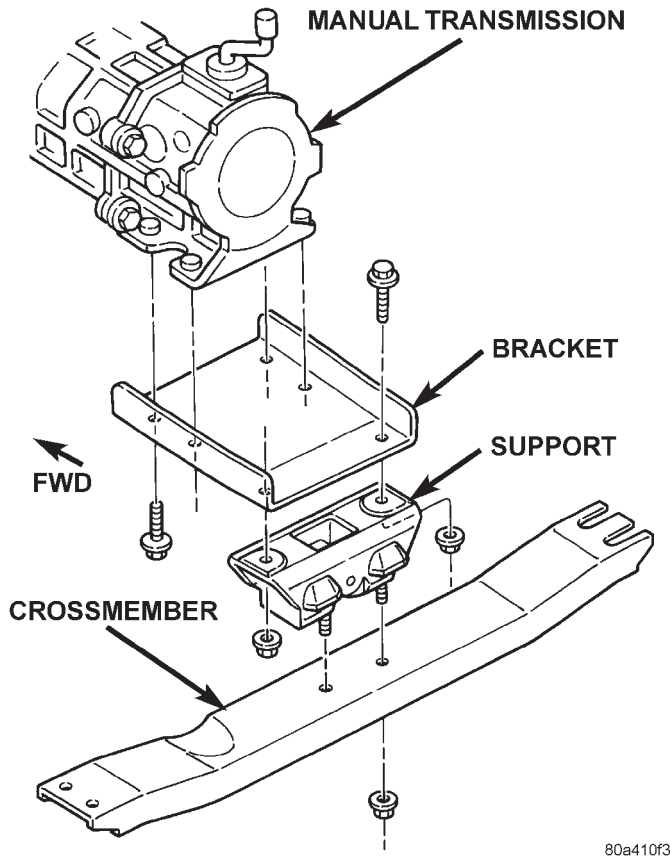
A resilient rubber cushion supports the transmission at the rear between the transmission extension housing and the rear support crossmember or skid plate.

REMOVAL

- (1) Disconnect negative cable from battery.
- (2) Raise the vehicle and support the transmission.
- (3) Remove the nuts holding the support cushion to the bracket (Fig. 8). Remove the crossmember.
 - (a) Remove the support cushion nuts and remove the cushion.

REMOVAL AND INSTALLATION (Continued)

(b) If necessary, remove the bolts holding the transmission support bracket to the transmission. Remove the bracket.



80a410f3

Fig. 8 Rear Mount

INSTALLATION

- (1) If removed, position the transmission support bracket to the transmission and install the bolts. Tighten the bolts to 46 N·m (34 ft. lbs.) torque.
- (2) Position the support cushion onto the transmission support crossmember. Tighten the nuts to 54 N·m (40 ft. lbs.) torque.
- (3) Install crossmember.
- (4) Secure support cushion to bracket. Tighten the nuts to 54 N·m (40 ft. lbs.) torque.
- (5) Remove transmission support and lower vehicle.
- (6) Connect negative battery cable.

ENGINE ASSEMBLY

REMOVAL

- (1) Disconnect the battery cables. Remove the battery.
- (2) Mark the hinge locations on the hood panel for alignment reference during installation. Disconnect the engine compartment lamp wiring connection. Remove the hood.

WARNING: THE COOLANT IN A RECENTLY OPERATED ENGINE IS HOT AND PRESSURIZED. USE CARE TO PREVENT SCALDING BY HOT COOLANT. CAREFULLY RELEASE THE PRESSURE BEFORE REMOVING THE RADIATOR DRAIN COCK AND CAP.

- (3) Drain the cooling system (refer to Group 7, Cooling).
- (4) Discharge the air conditioning system, if equipped (refer to Group 24, Heating and Air Conditioning for service procedures).
- (5) Remove the lower radiator hose.
- (6) Remove the upper radiator hose and coolant recovery hose (Fig. 9).
- (7) Remove upper crossmember, refer to Group 23, Body Components for procedure.
- (8) Remove air cleaner hose from turbocharger and breather hose.
- (9) Remove the air cleaner assembly.
- (10) Disconnect A/C lines from condenser (Refer to Group 24, Heating and Air Conditioning) cap lines to keep foreign particles out.

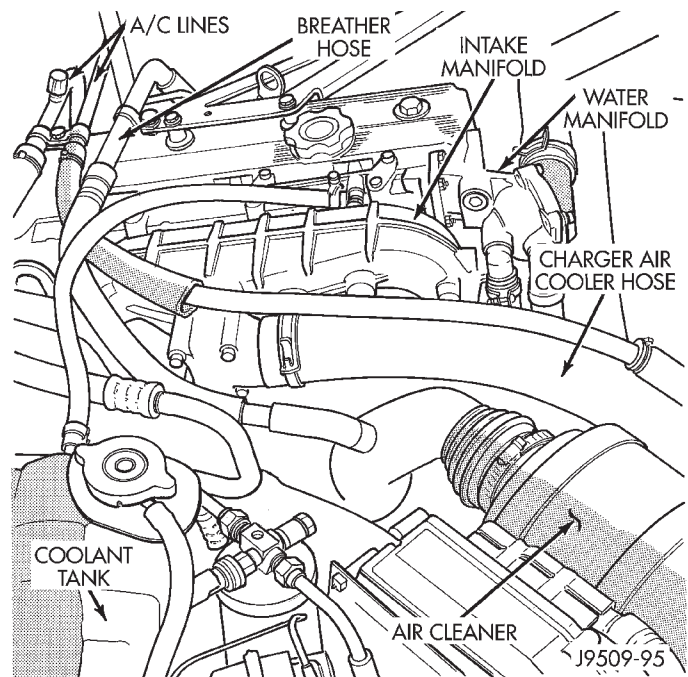


Fig. 9 Right side of Engine

- (11) Tip radiator, A/C condenser, and fan shroud assembly away from engine.
- (12) Remove fan and set fan inside fan shroud.
- (13) Remove fan, fan shroud, radiator, and A/C condenser as an assembly.
- (14) Disconnect the heater hoses and coolant recovery bottle hose (Fig. 9).
- (15) Remove fuel lines, fuel filter, refer to Group 14, Fuel Systems.
- (16) If equipped with air conditioning, remove the service valves and cap the compressor ports (refer to Group 14, Fuel System).

REMOVAL AND INSTALLATION (Continued)

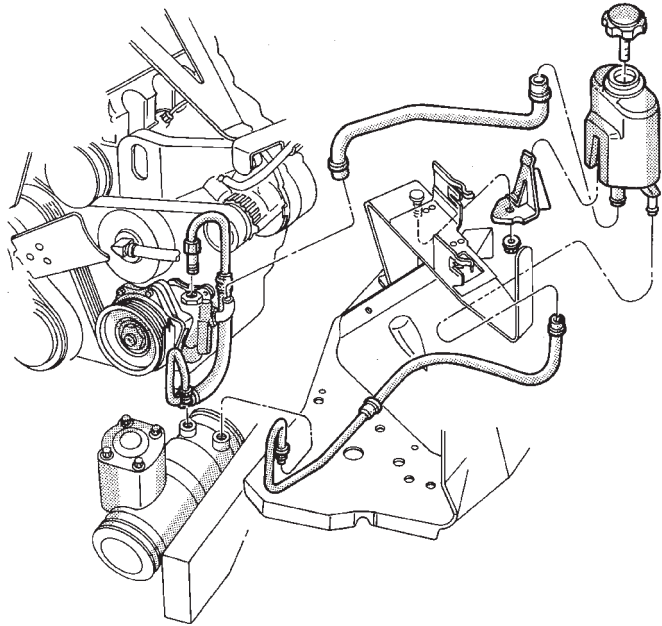
(17) Remove the power brake vacuum check valve from the booster, if equipped.

(18) If equipped with power steering (Fig. 10):

(a) Disconnect the power steering pressure hoses from the steering gear.

(b) Disconnect return line from reservoir and drain the pump reservoir.

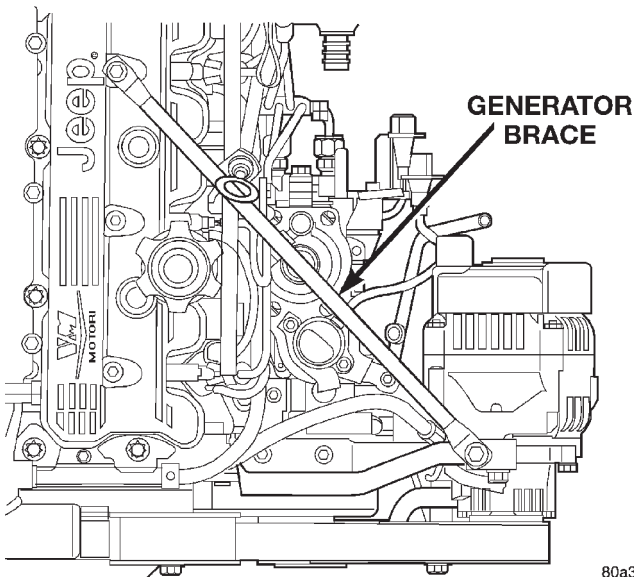
(c) Cap the fittings on the hoses and steering gear to prevent foreign material from entering the system.



J9519-18

Fig. 10 Power Steering Lines

(19) Identify, tag and disconnect all necessary wire connectors and vacuum hoses.



80a3b1a9

Fig. 11 Left Side of Engine

(20) Remove gear shift levers (refer to Group 21, Transmissions).

(21) Raise and support the vehicle.

(22) Remove Prop shafts (refer to Group 2, Suspension and Driveshafts).

(23) Disconnect the exhaust pipe from the exhaust down manifold (refer to Group 11, Exhaust system and Intake Manifolds).

(24) Remove rear crossmember and transmission mount, support transmission.

(25) Tip transmission to remove four bolts on top of transmission to engine block. Disconnect wiring from transmission.

(26) Support transmission, remove lower bolts and brackets, remove transmission.

(27) Remove the engine support cushion-to-engine compartment bracket nuts.

(28) Lower the vehicle.

(29) Attach a lifting device to the engine.

(30) Lift the engine out of the engine compartment. Install the engine on an engine stand.

INSTALLATION

(1) Lift the engine off the stand and lower it into the engine compartment.

(2) Install the engine support cushions (if removed).

(3) Lower the engine and engine support cushions onto the engine compartment brackets.

(4) Raise the vehicle.

(5) Install transmission to engine refer to Group 21, transmissions.

(6) Support transmission.

(7) Remove the engine lifting device.

(8) Install rear crossmember tighten bolts to 42 N·m (31 ft. lbs.).

(9) Install transmission rear mount, for procedure refer to Engine Mount—Rear in this section.

(10) Tighten the engine support cushion through-bolt nuts 65 N·m (48 ft. lbs.).

(11) Install the exhaust pipe support.

(12) Connect the exhaust down pipe to the exhaust system refer to Group 11, Exhaust System and Intake Manifold.

(13) Lower the vehicle.

(14) Connect all the vacuum hoses and wire connectors.

(15) If equipped with power steering:

(a) Remove the protective caps.

(b) Connect the pressure hoses to the steering gear. Tighten the nut to 28 N·m (21 ft. lbs.).

(c) Connect return line from reservoir to the pump.

(d) Fill the pump reservoir with fluid.

(16) Connect the service valves to the A/C compressor ports, if equipped with air conditioning.

REMOVAL AND INSTALLATION (Continued)

- (17) Install fuel filter and bracket. Tighten bolts to 28 N·m (250 in. lbs.).
- (18) Connect the fuel supply and return lines.
- (19) Connect brake booster hose.
- (20) Connect the heater hoses and recovery bottle hose.
- (21) Connect charge air cooler hoses to turbo and intake manifold.
- (22) Install the fan, fan shroud and radiator/condenser (if equipped with air conditioning).
- (23) Install fan, tighten to 56 N·m (41 ft. lbs.).
- (24) Connect the upper and lower radiator hoses.
- (25) Install upper crossmember, refer to Group 23, Body Components.
- (26) Install air cleaner and bracket.
- (27) Connect air cleaner hose to turbo and connect breather hose.
- (28) Install battery tray and battery.
- (29) Connect the battery cables.
- (30) Fill the cooling system.
- (31) If equipped, If system was opened, evacuate and charge the air conditioning system (refer to Group 24, Heater and Air Conditioning).
- (32) Install the hood.
- (33) Install the air cleaner.
- (34) Start the engine and inspect for leaks.
- (35) Stop the engine and check the fluid levels. Add fluid, as required.

CYLINDER HEAD COVER

REMOVAL

- (1) Disconnect the battery cable.

WARNING: DO NOT REMOVE THE CYLINDER BLOCK DRAIN PLUGS OR LOOSEN THE RADIATOR DRAIN COCK WITH THE SYSTEM HOT AND PRESSURIZED BECAUSE SERIOUS BURNS FROM THE COOLANT CAN OCCUR.

- (2) Drain the cooling system (refer to Group 7, Cooling).
- (3) Discharge the air conditioning system, if equipped (refer to Group 24, Heating and Air Conditioning for service procedures).
- (4) If equipped with air conditioning, remove the A/C lines at the compressor and cap (refer to Group 24, Heating and Air Conditioning). Remove A/C line bracket attached to cylinder head cover, and move A/C lines away from cylinder head.
- (5) Remove generator support brace (Fig. 12).
- (6) Remove Crankcase breather hose from rear of the valve cover
- (7) Remove the upper radiator hose and coolant tank hose.
- (8) Remove water manifold.

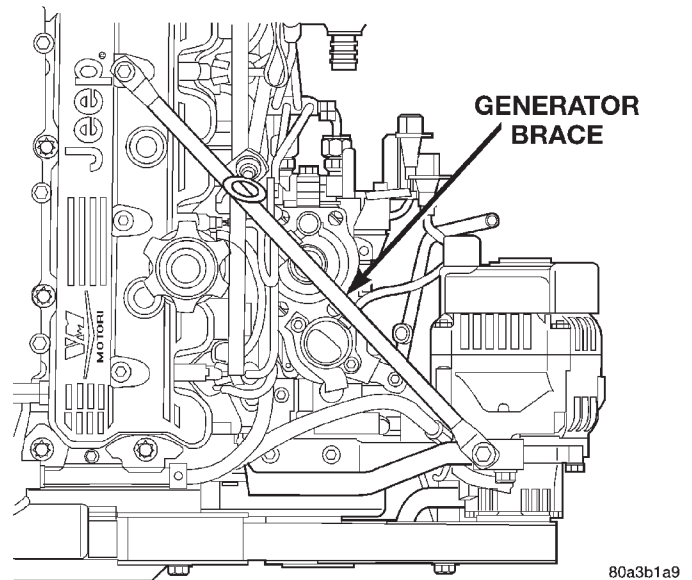


Fig. 12 Generator Brace

- (9) Loosen cylinder head cover bolts and raise cylinder head cover.
- (10) Raise vehicle on hoist.
- (11) Support transmission with a suitable jack.
- (12) Remove lower attaching bolt.
- (13) Remove entire crossmember.
- (14) Take the lowest brake line on dash out of all the mounting clips (RHD Vehicles only).
- (15) Lower the entire transmission and transfer case assembly approximately 130 mm.

WARNING: Ensure the transmission and transfer case are adequately supported.

- (16) Remove the engine cylinder head cover.

INSTALLATION

- (1) Position valve cover on cylinder heads.
- (2) Raise the entire transmission and transfer case assembly approximately 130 mm.
- (3) Reinstall the lowest brake line on dash into all the mounting clips (RHD Vehicles only).
- (4) Install the entire crossmember.
- (5) Install the lower attaching bolt.
- (6) Install transmission support.
- (7) Lower vehicle.
- (8) Install valve cover, tighten nuts to 19 N·m (168 in. lbs.).
- (9) Connect crankcase breather hose.
- (10) Install water manifold and tighten bolts to 12 N·m (106 in. lbs.).
- (11) Install generator support brace.
- (12) Connect coolant tank hose to water manifold.
- (13) Connect the upper radiator hose.

REMOVAL AND INSTALLATION (Continued)

(14) Connect the A/C lines to compressor and install bracket on cylinder head cover, if equipped with air conditioning.

(15) Connect negative cable to battery.

(16) If equipped with A/C, evacuate and charge the air conditioning system (refer to Group 24, Heater and Air Conditioning).

(17) Fill the cooling system. Check for leaks.

WARNING: USE EXTREME CAUTION WHEN THE ENGINE IS OPERATING. DO NOT STAND IN DIRECT LINE WITH THE FAN. DO NOT PUT HANDS NEAR THE PULLEYS, BELTS OR FAN. DO NOT WEAR LOOSE CLOTHING.

(18) Operate the engine with the radiator cap off. Inspect for leaks and continue operating the engine until the thermostat opens. Add coolant, if required.

HYDRAULIC TAPPETS

REMOVAL

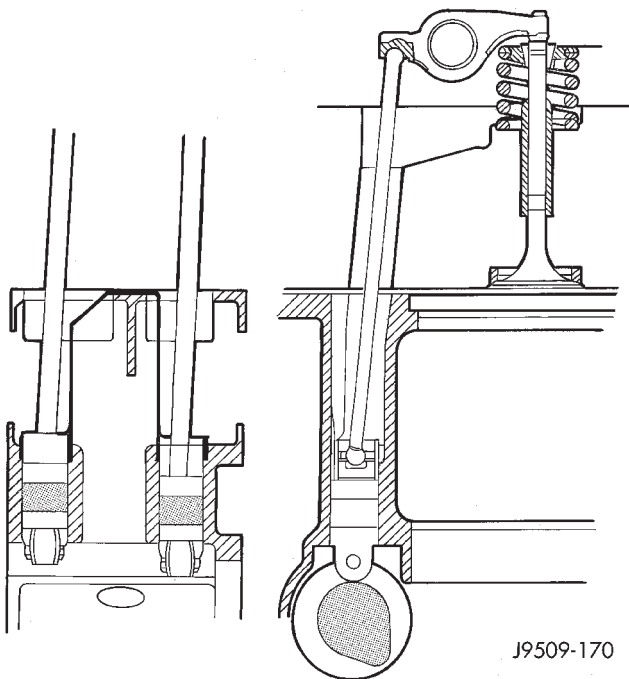
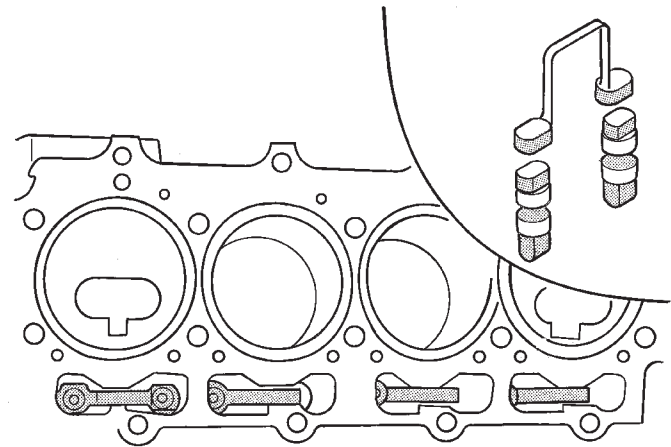


Fig. 13 Tappet And Rocker Arm Assembly

- (1) Remove the air cleaner.
- (2) Remove cylinder head cover (refer to cylinder valve cover removal in this section).
- (3) Remove rocker assembly and push rods (Fig. 13). Identify push rods to ensure installation in original location.
- (4) Remove cylinder head, intake manifold, and exhaust manifold, refer to cylinder head removal in this section.
- (5) Remove yoke retainer and aligning yokes (Fig. 14).



J9509-169

Fig. 14 Tappet And Yoke

(6) Slide Hydraulic Tappet Remover/Installer Tool through opening in block and seat tool firmly in the head of tappet.

(7) Pull tappet out of bore with a twisting motion. If all tappets are to be removed, identify tappets to ensure installation in original location.

(8) If the tappet or bore in cylinder block is scored, scuffed, or shows signs of sticking, ream the bore to next oversize. Replace with oversize tappet.

CAUTION: The plunger and tappet bodies are not interchangeable. The plunger and valve must always be fitted to the original body. It is advisable to work on one tappet at a time to avoid mixing of parts. Mixed parts are not compatible. DO NOT disassemble a tappet on a dirty work bench.

INSTALLATION

- (1) Lubricate tappets.
- (2) Install tappets and yoke retainers in their original positions. Ensure that the oil feed hole in the side of the tappet body faces up (away from the crankshaft).
- (3) Install cylinder head, intake manifold, and exhaust manifold, refer to cylinder head installation in this section.
- (4) Install push rods in original positions.
- (5) Install rocker arms (refer to rocker arms in this section).
- (6) Install cylinder head cover (refer to cylinder valve cover installation in this section).
- (7) Start and operate engine. Warm up to normal operating temperature.

CAUTION: To prevent damage to valve mechanism, engine must not be run above fast idle until all hydraulic tappets have filled with oil and have become quiet.

REMOVAL AND INSTALLATION (Continued)

ROCKER ARMS AND PUSH RODS

REMOVAL

- (1) Disconnect the battery cables.
- (2) Discharge the air conditioning system, if equipped (refer to Group 24, Heating and Air Conditioning for service procedures).
- (3) If equipped with air conditioning, remove the service valves and cap the compressor ports (refer to Group 24, Heating and Air Conditioning).
- (4) Remove generator bracket.
- (5) Remove breather hose.
- (6) Remove cylinder head cover.
- (7) Remove rocker retaining nut (Fig. 15).

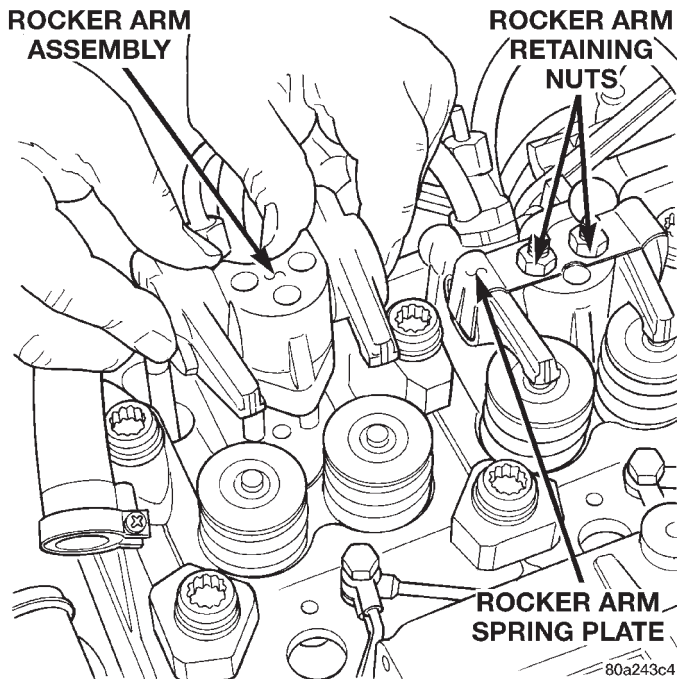


Fig. 15 Rocker Arm Retaining Nut

- (8) Remove rocker assembly. Place them on a bench in the same order as removed.
- (9) Remove the push rods and place them on a bench in the same order as removed.

INSTALLATION

- (1) Rotate the crankshaft until the mark lines up with the TDC mark on the timing cover.
- (2) Install the push rods in the same order as removed.
- (3) Install rocker arm assemblies in the same order as removed. Tighten the rocker arm nuts to 29.4 N·m (264 in. lbs.) torque.
- (4) Install cylinder head cover, torque nuts to 19 N·m (168 in. lbs.).
- (5) Install breather hose.
- (6) Install generator bracket, tighten bolts to 7 N·m (4 ft. lbs.).

(7) Connect the service valves to the A/C compressor ports, if equipped with air conditioning.

(8) If equipped, evacuate and charge the air conditioning system (refer to Group 24, Heater and Air Conditioning).

(9) Connect battery cable.

VALVE SPRINGS

This procedure can be done with the engine cylinder head installed on the block.

REMOVAL

Each valve spring is held in place by a retainer and a set of conical valve locks. The locks can be removed only by compressing the valve spring.

(1) Remove the engine cylinder head cover, refer to cylinder head cover removal in this section.

(2) Remove rocker arms assemblies for access to each valve spring to be removed.

(3) Remove push rods. Retain the push rods, and rocker arms assemblies in the same order and position as removed.

(4) Inspect the springs and retainer for cracks and possible signs of weakening.

(5) Install an air hose adaptor in the fuel injector hole.

(6) Connect an air hose to the adapter and apply air pressure slowly. Maintain at least 621 kPa (90 psi) of air pressure in the cylinder to hold the valves against their seats.

(7) Tap the retainer or tip with a rawhide hammer to loosen the lock from the retainer. Use Valve Spring Compressor Tool to compress the spring and remove the locks.

(8) Remove valve spring and retainer.

(9) Inspect the valve stems, especially the grooves. An Arkansas smooth stone should be used to remove nicks and high spots.

INSTALLATION

(1) Install valve spring and retainer.

(2) Compress the valve spring with Valve Spring Compressor Tool and insert the valve locks. Release the spring tension and remove the tool. Tap the spring from side-to-side to ensure that the spring is seated properly on the engine cylinder head.

(3) Disconnect the air hose. Remove the adaptor from the fuel injector hole and install the fuel injector.

(4) Repeat the procedures for each remaining valve spring to be removed.

(5) Install the push rods. Ensure the bottom end of each rod is centered in the plunger cap seat of the hydraulic valve tappet.

(6) Install the rocker arm assemblies, at their original location.

REMOVAL AND INSTALLATION (Continued)

(7) Tighten the rocker arm assembly nut to 35 N·m (26 ft. lbs.) torque.

(8) Install the engine cylinder head cover, refer to cylinder head cover installation in this section.

ENGINE CYLINDER HEAD**REMOVAL**

(1) Disconnect the battery cable.

WARNING: DO NOT REMOVE THE CYLINDER BLOCK DRAIN PLUGS OR LOOSEN THE RADIATOR DRAIN COCK WITH THE SYSTEM HOT AND PRESSURIZED BECAUSE SERIOUS BURNS FROM THE COOLANT CAN OCCUR.

(2) Drain the cooling system (refer to Group 7, Cooling).

(3) Discharge the air conditioning system, if equipped (refer to Group 24, Heating and Air Conditioning for service procedures).

(4) If equipped with air conditioning, remove the A/C lines at the compressor and cap (refer to Group 24, Heating and Air Conditioning). Remove A/C line bracket attached to cylinder head cover, and move A/C lines away from cylinder head.

(5) Remove air cleaner hose from turbocharger and breather hose.

(6) Remove the air cleaner assembly and breather hose.

(7) Remove generator support bracket.

(8) Loosen cylinder head cover bolts.

(9) Raise vehicle on hoist.

(10) Remove transmission crossmember bolts, and lower rear of engine.

(11) Remove the upper radiator hose and coolant recovery hose.

(12) Remove water manifold and recovery hose.

(13) Disconnect the heater hoses and coolant recover bottle hose.

(14) Disconnect EGR tube from EGR valve.

(15) Remove EGR valve.

(16) Remove exhaust heat shield from exhaust manifold.

(17) Remove exhaust heat shield from down pipe.

(18) Remove exhaust down pipe from turbocharger (Fig. 16).

(19) Disconnect oil feed line from turbocharger.

(20) Disconnect oil drain line from turbocharger.

(21) Remove Exhaust manifold (refer to Group 11, Exhaust System and Intake Manifold).

(22) Remove Intake manifold (refer to Group 11, Exhaust System and Intake Manifold).

(23) Remove oil feed line for rocker arm assemblies (Fig. 17).

(24) Remove Crankcase breather hose from rear of the valve cover.

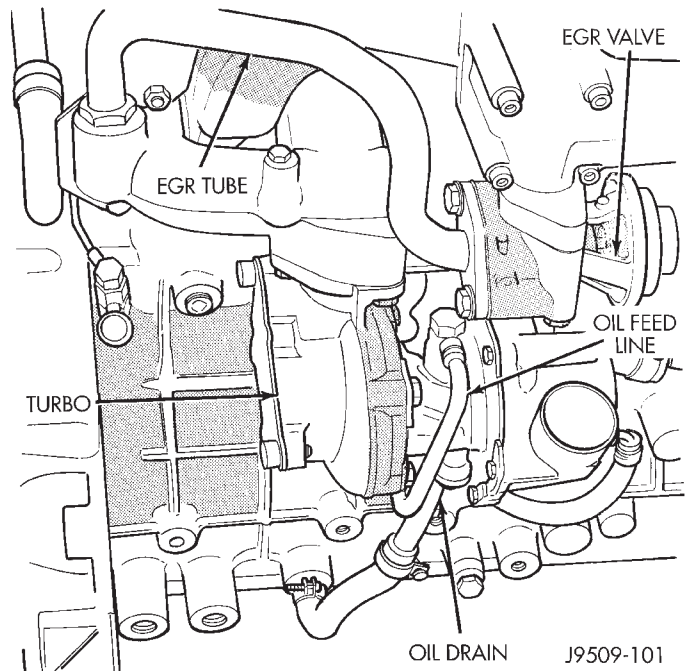


Fig. 16 Turbocharger

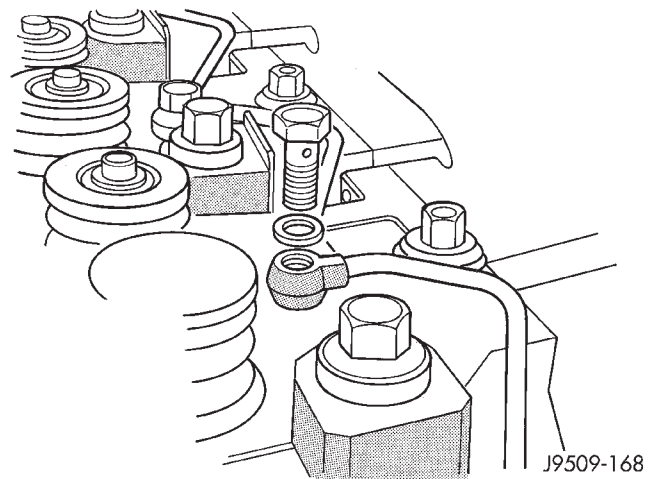


Fig. 17 Rocker Arm Oil Feed Lines

(25) Remove the injector sensor wire and the glow plug hot lead.

(26) Remove fuel lines, fuel filter, refer to Group 14, Fuel Systems.

(27) Remove injector fuel lines from injectors to pump.

(28) Remove fuel injectors with tool VM-1012A (Fig. 18) (refer to Group 14, Fuel System).

(29) Remove the engine cylinder head cover.

(30) Remove rocker retaining nuts (Fig. 20).

(31) Remove rocker assembly. Place them on a bench in the same order as removed.

(32) Remove the push rods and place them on a bench in the same order as removed.

(33) Mark cylinder head positions.

REMOVAL AND INSTALLATION (Continued)

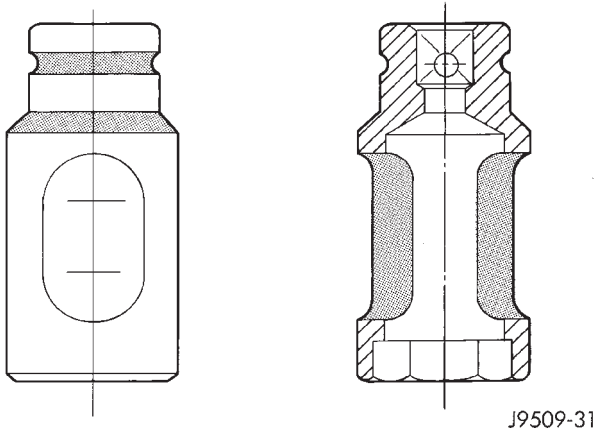


Fig. 18 Fuel Injector Tool VM-1012A

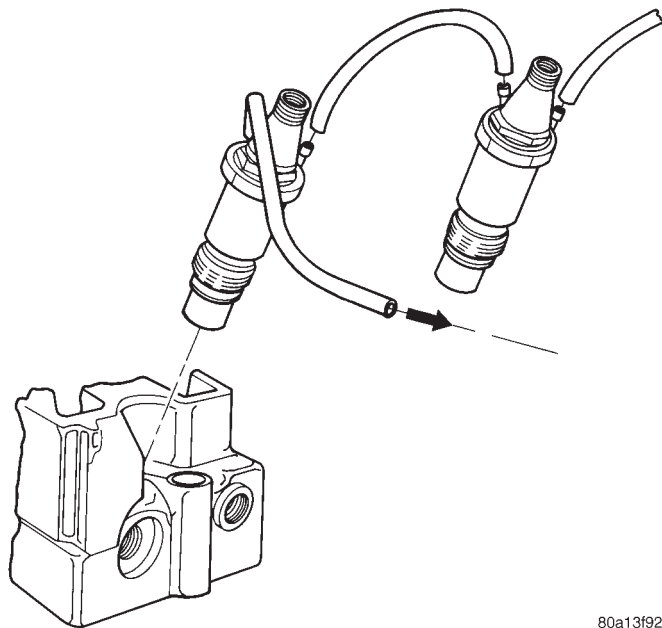


Fig. 19 Fuel Injector

(34) Remove the engine cylinder head bolts with special tool VM-1018 and VM-1019.

(35) Remove the engine cylinder head and gasket.

(36) Stuff clean lint free shop towels into the cylinder bores.

CYLINDER HEAD GASKETS

A steel cylinder head gasket is used for all four cylinder heads.

Cylinder head gaskets are available in three thicknesses. Identification holes in the right front corner of the gasket indicate the thickness of the gasket (Fig. 21).

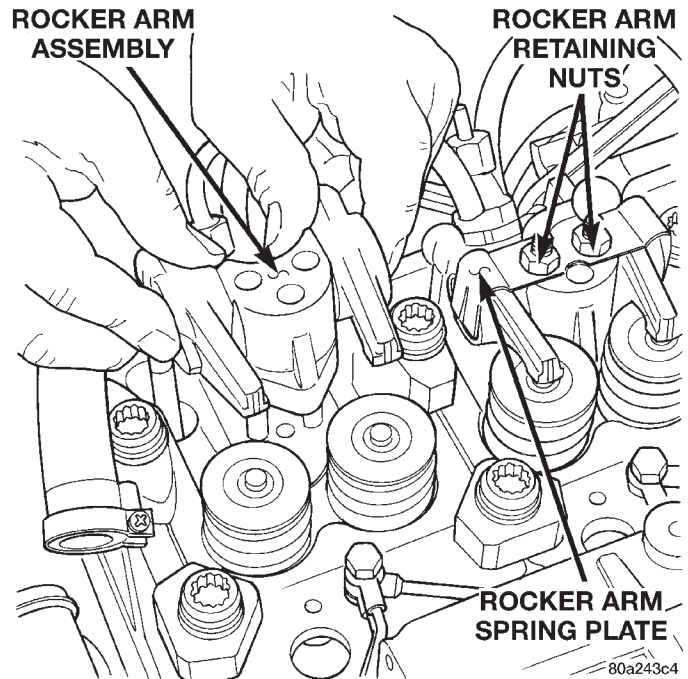
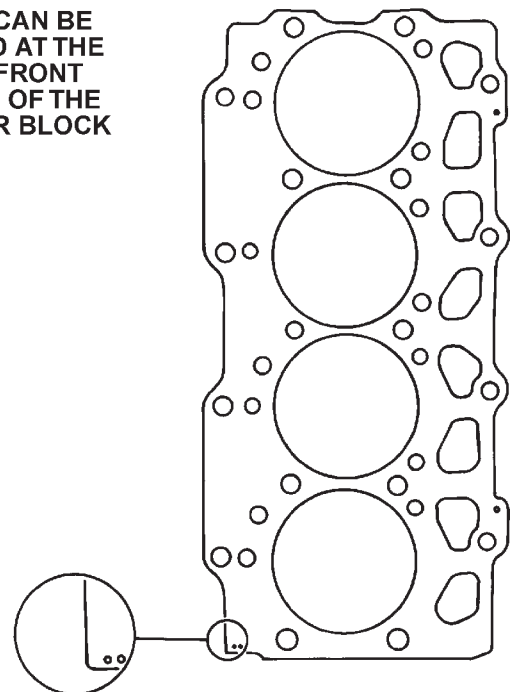


Fig. 20 Rocker Arm Retaining Nuts

HOLES CAN BE LOCATED AT THE RIGHT FRONT CORNER OF THE CYLINDER BLOCK



HOW TO IDENTIFY GASKET THICKNESS	
NO HOLES	1.42 mm
2 HOLES	1.52 mm
1 HOLE	1.62 mm

80a2b412

Fig. 21 Steel Type Cylinder Head Gasket—identification

CAUTION: Piston protrusion must be measured, to determine cylinder head gasket thickness, if one or more cylinder wall liners have been replaced.

REMOVAL AND INSTALLATION (Continued)

NOTE: If cylinder wall liners have not been removed; the same thickness head gasket removed, may be used.

MEASURING PISTON PROTRUSION

(1) Use special tool VM-1010 with dial indicator special tool VM-1013 (Fig. 22).

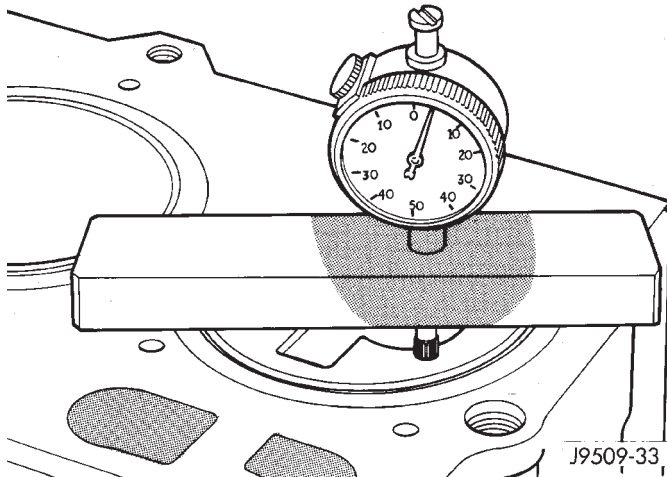


Fig. 22 Measuring Piston Protrusion

(2) Bring the piston of cylinder no. 1 exactly to top dead center.

(3) Zero the dial indicator on the cylinder block mating surface.

(4) Setup the dial indicator on the piston crown (above the center of the piston pin) 5mm (1/8 in.) from the edge of the piston and note the measurement (Fig. 23).

(5) Repeat the procedure with the rest of the cylinders.

(6) Establish the thickness of the steel gasket for all four cylinder heads on the basis of the greatest piston protrusion (Fig. 21).

Measured dimension (mm)	0.53 - 0.62
Cyl. head gasket thickness (mm)	1.42
Piston clearance (mm)	0.80 - 0.89
Measured dimension (mm)	0.63 - 0.72
Cyl. head gasket thickness (mm)	1.52
Piston clearance (mm)	0.80 - 0.89
Measured dimension (mm)	0.73 - 0.82
Cyl. head gasket thickness (mm)	1.62
Piston clearance (mm)	0.80 - 0.89

J9509-164

Fig. 23 Piston Protrusion Chart

CAUTION: Gaskets are to be installed DRY. DO NOT use a gasket sealing compound on the gasket.

INSTALLATION

(1) Remove the shop towels from the cylinder bores. Coat the bores with clean engine oil.

(2) Install cylinder head alignment studs (VM-1009).

(3) After determining the correct head gasket thickness, clean the block and head mating surfaces, place the engine cylinder head gasket over the dowels.

(4) Place the engine cylinder head over the dowels.

CAUTION: New cylinder head bolts should be used.

(5) Tighten the engine cylinder head bolts in sequence according to the following procedure (Fig. 24):

(a) The threads and underside heads of the bolts should be lubricated. Use the cylinder head alignment studs tool number VM-1009. Position the heads on the block and secure with the ten large center bolts and spacers (clamps), finger tight only. Be sure that the various clamps are installed correctly and the head gaskets remain in their proper position, completely covered. Then, lubricate and install the eight small bolts, also finger tight.

(6) Hand tighten oil feed line for rocker arm assemblies.

(7) Install the intake and exhaust manifolds with new gaskets, partially tightening the nuts to a maximum of 5 N·m (44 in. lbs.). This will align the heads (refer to Group 11, Exhaust System and Intake Manifold for the proper procedures).

(8) Then, tighten the 12mm bolts with special tool VM-1019 in the following manner:

1st Phase: Head Bolts Tightening -- (Fig. 24)

Central bolts (A-L): Tighten all bolts, starting with bolt A then B-C-D-E-F-G-H-I-L, to 30 N·m. Repeat the operation with the same torque. Following the same sequence rotate each bolt through an angle of 70° using angle torque tool. Then rotate the bolts an additional 70° following tightening sequence.

(9) Then, tighten the 14mm bolts with special tool VM-1018 in the following manner:

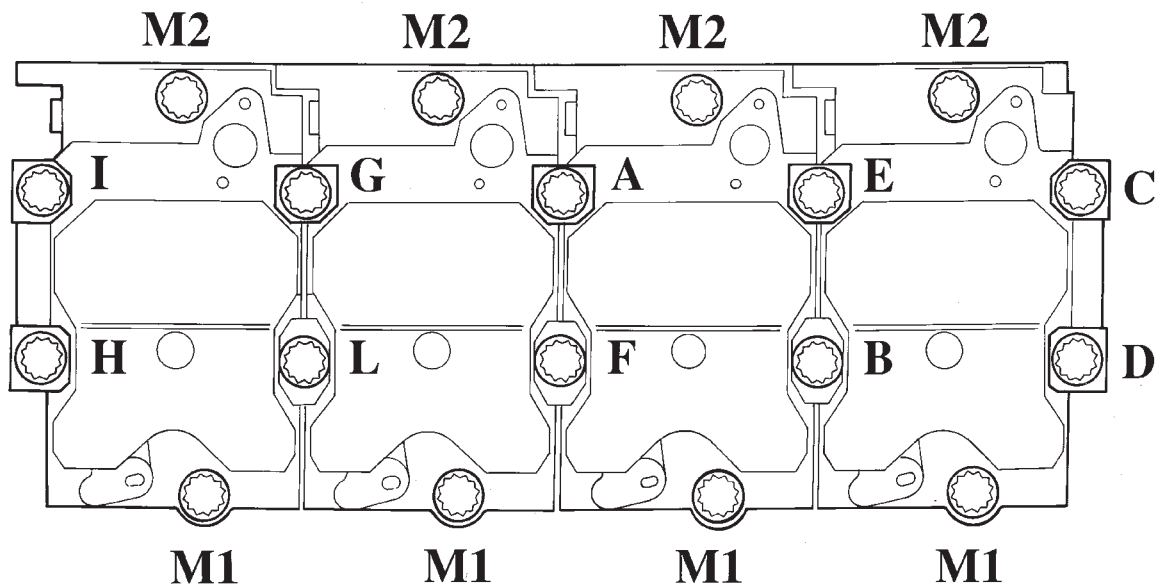
Side bolts (M1-M2): Tighten M1 bolts to 30 N·m, then rotate them 85°(+/-5). Tighten M2 bolts to 30 N·m, then rotate them 85°(+/-5).

NOTE: If vehicle is equipped with A/C do not install A/C lines to compressor and charge A/C till Phase 2 is complete.

(10) 2nd Phase: After 20 minutes of engine operation at operating temperature, allow engine to cool down completely. Then re-torque the head bolts as follows:

Central bolts A-L: Starting from bolt A, slacken and re-torque it immediately to 30 N·m + 65°. Rotate the bolt an additional 65°. Then proceed in the same

REMOVAL AND INSTALLATION (Continued)



J9509-41

Fig. 24 Engine Cylinder Head Bolt Tightening Sequence

way, bolt by bolt, following alphabetical order, as indicated.

Side bolts M1-M2: **Without slackening**, torque bolts M1 then bolts M2 to 90 N·m (66 ft. lbs.).

(11) Tighten intake nuts to 30 N·m (22 ft. lbs.) and exhaust manifolds nuts to 30 N·m (22 ft. lbs.) specified torque after completing Phase 2.

If the engine cylinder head is to be replaced and the original valves used, measure the valve stem diameter. Only standard size valves can be used with a service replacement engine cylinder head unless the replacement head valve stem guide bores are reamed to accommodate oversize valve stems. Remove all carbon buildup and reface the valves.

(12) Tighten oil feed lines for rocker arm assemblies to 13 N·m (112 in. lbs.).

(13) Install push rods and rocker arm assemblies, tighten nut to 35 N·m (26 ft. lbs.).

(14) Install valve cover, tighten nuts to 19 N·m (168 in. lbs.).

(15) Connect crankcase breather hose.

(16) Connect the injector sensor wire and the glow plug hot lead.

(17) Install turbocharger oil feed line, tighten banjo bolts to 27 N·m (20 ft. lbs), and install oil drain line to turbocharger.

(18) Install water manifold and tighten bolts to 12 N·m (106 in. lbs.).

(19) Install generator support bracket.

(20) Raise vehicle on hoist.

(21) Install transmission crossmember bolts.

(22) Install exhaust down pipe to turbocharger, tighten bolts to 22 N·m (16 ft. lbs.).

(23) Install exhaust down pipe heat shield.

(24) Install exhaust heat shield, Tighten bolts to 11 N·m (8 ft. lbs.).

(25) Install EGR valve to intake manifold, tighten bolts to 26 N·m (19 ft. lbs.).

(26) Install EGR tube to EGR valve, tighten bolts to 26 N·m (19 ft. lbs.).

(27) Install lower Charge air cooler hose to turbocharger.

(28) Install air cleaner assembly and hose.

(29) Install oil breather hose to air cleaner hose.

(30) Install upper charge cooler hose to turbocharger.

(31) Connect recover bottle hose to water manifold.

(32) Install fuel injectors use tool VM-1012 (refer to Group 14, Fuel System).

(33) Install fuel injector lines from the pump to injectors, tighten nuts to 23 N·m (17 ft. lbs.).

(34) Connect the A/C lines to compressor and install bracket on cylinder head cover, if equipped with air conditioning.

(35) Install fuel filter, Tighten bolts to 28 N·m (250 in. lbs.).

(36) Connect the fuel supply and return lines.

(37) Connect the upper radiator hose.

(38) Connect negative cable to battery.

(39) If equipped with A/C, evacuate and charge the air conditioning system (refer to Group 24, Heater and Air Conditioning).

(40) Fill the cooling system. Check for leaks.

REMOVAL AND INSTALLATION (Continued)

WARNING: USE EXTREME CAUTION WHEN THE ENGINE IS OPERATING. DO NOT STAND IN DIRECT LINE WITH THE FAN. DO NOT PUT HANDS NEAR THE PULLEYS, BELTS OR FAN. DO NOT WEAR LOOSE CLOTHING.

(41) Operate the engine with the radiator cap off. Inspect for leaks and continue operating the engine until the thermostat opens. Add coolant, if required.

CAUTION: After rebuild or cylinder head gasket replacement, the cylinder head must be retorqued within the first 20,000km. If individual fiber type head gaskets were used.

NOTE: The one piece steel type head gasket does not require, the above mentioned, retorque procedure.

CYLINDER HEAD RE-TORQUE

Within the first 20,000 km after rebuild, retorque the head bolts as follows: (Fig. 24) Central bolts A-L: Without slackening the bolts, following alphabetical order tighten the bolts through an angle of 15°. Side bolts M1-M2: Without slackening, tighten M1 then M2 bolts through an angle of 15°.

VIBRATION DAMPER**REMOVAL**

- (1) Disconnect the battery cable.
- (2) Remove fan and set fan inside fan shroud then remove fan shroud and fan as an assembly.
- (3) Remove accessory drive belt, (refer to Group 7, Cooling).
- (4) Remove vibration damper nut.
- (5) Install tool VM-1000-2 to remove vibration damper (Fig. 26).

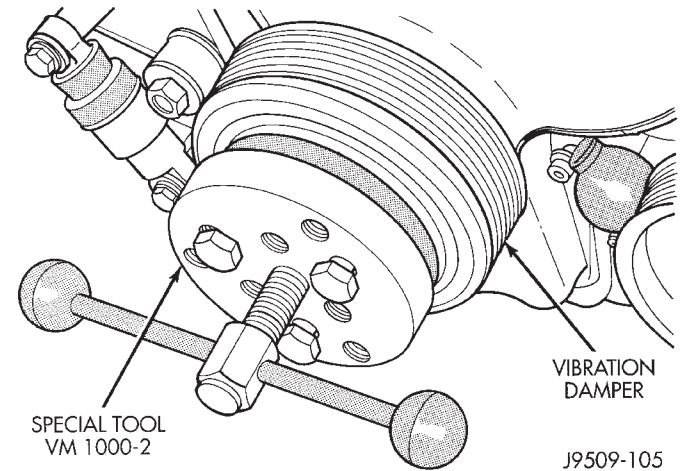


Fig. 26 Vibration Damper Removal With Tool VM-1000-2

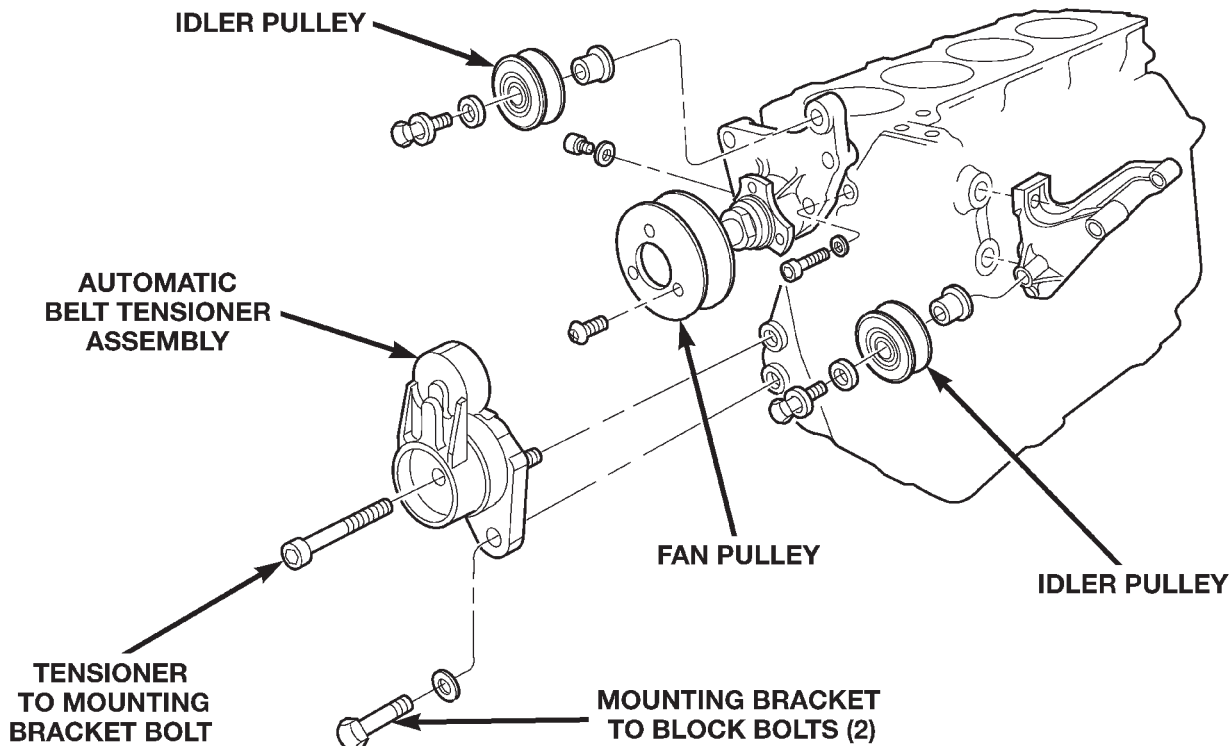


Fig. 25 Accessory Drive System

REMOVAL AND INSTALLATION (Continued)

INSTALLATION

- (1) Install vibration damper and align with key way.
- (2) Install vibration damper nut and tighten to 160 N·m (118 ft. lbs.).
- (3) Install accessory drive belt (refer to Group 7, Cooling).
- (4) Connect the battery cable.

TIMING CASE COVER OIL SEAL

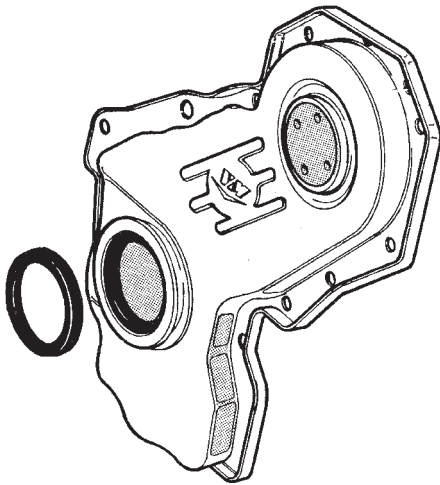
REMOVAL

- (1) Disconnect the battery cable.
- (2) Remove vibration damper (refer to vibration damper removal in this section).
- (3) Pry out seal.

INSTALLATION

Remove the oil seal ring. The seating diameter must be 68.000 - 68.030 mm.

- (1) Install new seal using special tool VM-1015.
- (2) Install vibration damper (refer to vibration damper installation in this section).
- (3) Connect the battery cable.



J9509-4

Fig. 27 Front Cover Seal

TIMING CASE COVER

REMOVAL

- (1) Disconnect the battery cable.
- (2) Remove fan and set fan inside fan shroud then remove fan shroud and fan as an assembly.
- (3) Remove accessory drive belt, (refer to Group 7, Cooling).
- (4) Remove vibration damper nut.
- (5) Install tool VM-1000-2 to remove vibration damper.
- (6) Remove fan pulley.
- (7) Remove idler pulley and bracket. Idler pulley bolt have left hand threads.
- (8) Remove the automatic belt tensioner.

(9) Disconnect the oil drain back hose from external vacuum pump to timing cover.

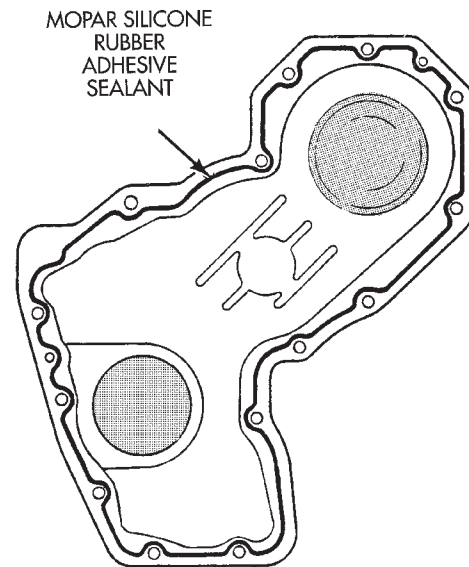
(10) Remove Power steering pulley.

(11) Remove cover.

INSTALLATION

(1) Be sure mating surfaces of chain case cover and cylinder block are clean and free from burrs.

(2) Apply a continuous 3 mm bead of Silicone Sealer (Fig. 28) to timing cover, install within 10 minutes, tighten 6mm bolts to 10.3 N·m (91 in. lbs) and tighten 8mm bolts to 26.2 N·m (19 ft. lbs.).



J9509-7

Fig. 28 Front Cover Sealer Location

(3) Install Power steering pulley, tighten to 130 N·m (96 ft. lbs.).

(4) Connect oil drain to cover.

(5) Install automatic belt tensioner.

(6) Install idler pulley bracket, tighten bolts to 40 N·m (29 ft. lbs.).

(7) Install idler pulley, bolt has left hand thread, tighten to 65 N·m (48 ft. lbs.).

(8) Install fan pulley, tighten bolts to 56 N·m (41 ft. lbs.).

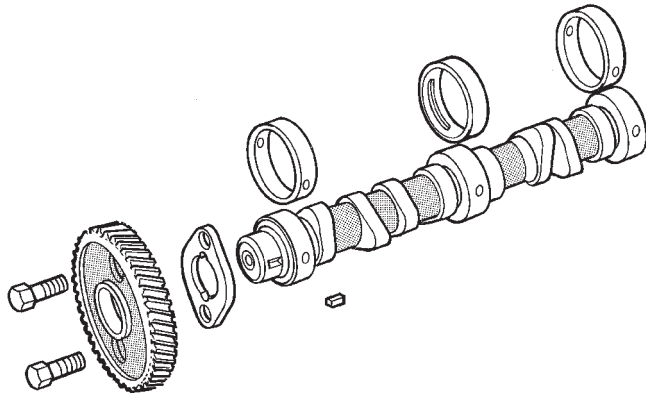
(9) Install vibration damper align with keyway.

(10) Tighten vibration damper nut to 160 N·m (118 ft. lbs.).

(11) Install accessory drive belt (refer to Group 7, cooling for procedure).

(12) Install fan and fan shroud (refer to Group 7, Cooling for procedure).

(13) Connect battery cable.

REMOVAL AND INSTALLATION (Continued)**CAMSHAFT****REMOVAL**

J9509-173

Fig. 29 Camshaft Assembly

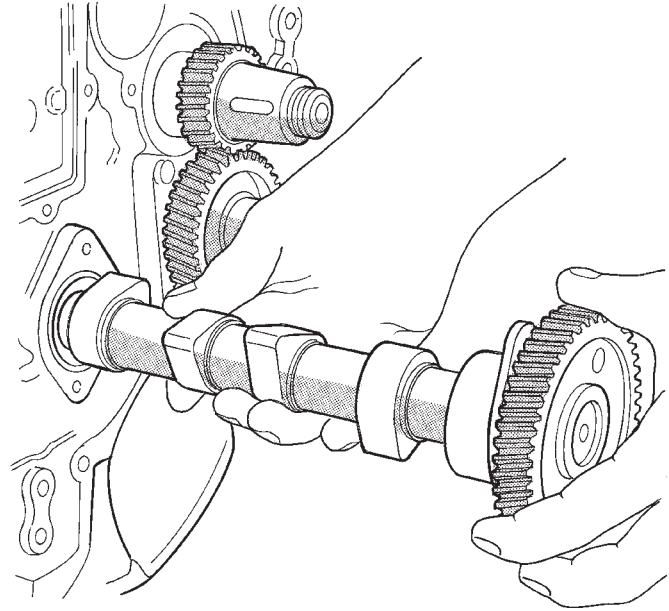
- (1) Disconnect the battery cable.
- (2) Remove valve cover, refer to valve cover removal in this section.
- (3) Remove cylinder head (refer to cylinder head removal in this section).
- (4) Remove rocker arms, push rods, and hydraulic tappets, refer to the respective groups in this section.
- (5) Remove fan and set fan inside fan shroud then remove fan shroud and fan as an assembly.
- (6) Remove accessory drive belt.
- (7) Remove radiator (refer to Group 7, Cooling).
- (8) Remove A/C condenser (refer to Group 24, Heating and Air Conditioning).
- (9) Remove vibration damper, refer to vibration damper removal in this section.
- (10) Remove power steering pulley.
- (11) Remove timing case cover, refer to timing case cover removal in this section.
- (12) Unscrew flange bolts and remove camshaft (Fig. 30).

THRUST PLATE INSPECTION

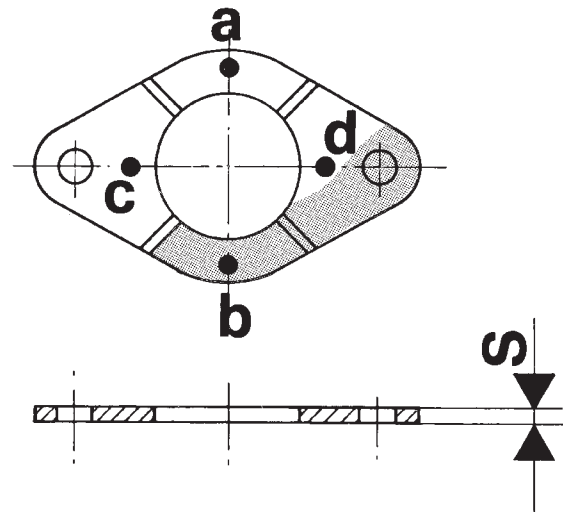
Check the thickness (Fig. 31) of the plate at points a-b-c-d. If the measurement is not between 3.950 - 4.050 it must be changed.

INSTALLATION

- (1) Coat the camshaft journals with clean engine oil and carefully install the camshaft complete with thrust plate and gear. Tighten retaining bolts to 24 N·m (18 ft. lbs.) torque. Be sure to align the timing marks as shown (Fig. 32).
- (2) Install hydraulic tappets and retaining yokes.
- (3) Install cylinder heads (refer to cylinder heads in this section).



J9509-15

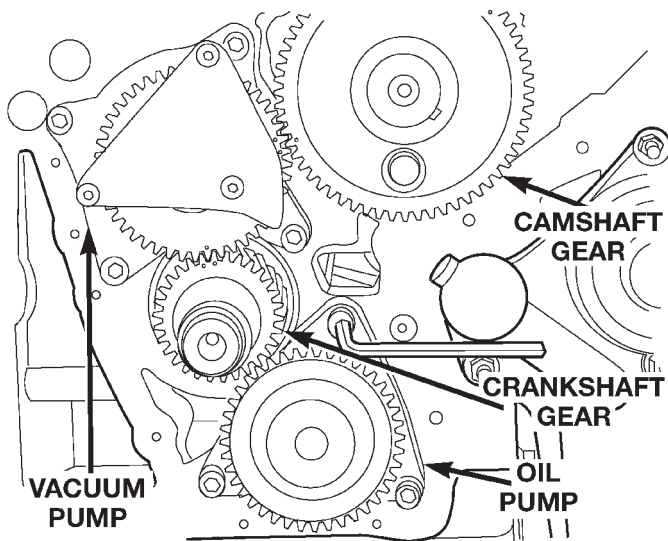
Fig. 30 Camshaft Removal

J9509-16

Fig. 31 Camshaft Thrust Plate

- (4) Push rods, and rocker arm assemblies, refer to the respective sections.
- (5) Install valve cover (refer to valve cover installation in this section).
- (6) Install Timing case cover (refer to the timing case cover installation in this section).
- (7) Install Vibration damper (refer to the vibration installation in this section).
- (8) Install the A/C condenser (refer to Group 24, Heating and Air Conditioning).

REMOVAL AND INSTALLATION (Continued)



80ae8458

Fig. 32 Timing Marks

- (9) Install radiator (refer to group 7, Cooling).
- (10) Install fan and fan shroud, tighten fan to 56 N·m (41 ft. lbs.).
- (11) If equipped, evacuate and charge the air conditioning system (refer to Group 24, Heater and Air Conditioning).
- (12) Fill the cooling system. Check for leaks.

WARNING: USE EXTREME CAUTION WHEN THE ENGINE IS OPERATING. DO NOT STAND IN DIRECT LINE WITH THE FAN. DO NOT PUT HANDS NEAR THE PULLEYS, BELTS OR FAN. DO NOT WEAR LOOSE CLOTHING.

- (13) Operate the engine with the radiator cap off. Inspect for leaks and continue operating the engine until the thermostat opens. Add coolant, if required.

CAMSHAFT BEARINGS

This procedure requires that the engine is removed from the vehicle.

REMOVAL

- (1) With engine completely disassembled, remove camshaft rear plate and o-ring.
- (2) Install proper size adapters and horseshoe washers (part of Camshaft Bearing Remover/Installer Tool) at back of each bearing shell. Drive out bearing shells.

INSTALLATION

- (1) Install new camshaft bearings with Camshaft Bearing Remover/Installer Tool by sliding the new camshaft bearing shell over proper adapter.

- (2) Position rear bearing in the tool. Install horseshoe lock and by reversing removal procedure, carefully drive bearing shell into place.

- (3) Install remaining bearings in the same manner. Bearings must be carefully aligned to bring oil holes into full register with oil passages from the main bearing. If the camshaft bearing shell oil holes are not in exact alignment, remove and install them correctly. Install a new rear plate o-ring at the rear of camshaft. **Be sure this seal does not leak.**

OIL PAN

REMOVAL

- (1) Disconnect battery cable.
- (2) Raise vehicle on hoist.
- (3) Drain oil.
- (4) Remove oil pan lower bolts on sump.
- (5) Remove bolts from lower oil pan. Remove the 4 bolts that are on the inside of the oil pan.
- (6) Remove oil pan.

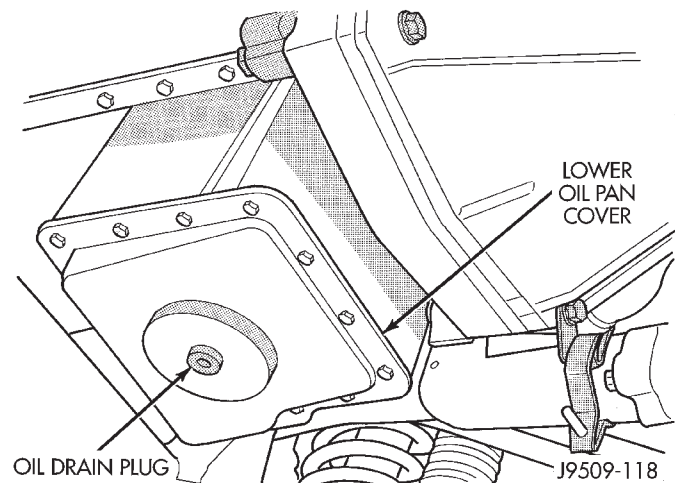


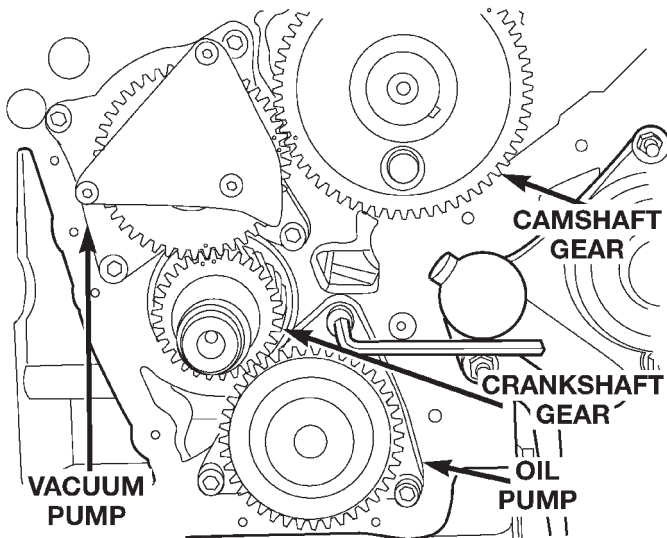
Fig. 33 Oil Pan

INSTALLATION

- (1) Remove all gasket material from cylinder block. Be careful not gouge or scratch aluminum pan sealing surface.
- (2) Install oil pan. Apply a continuous 3 mm bead of Silicone Sealer to oil pan, install within 10 minutes.
- (3) Install inside oil pan bolts and torque bolts to 11 N·m (8 ft. lbs.).
- (4) Install lower oil pan bolts and torque to 11 N·m (8 ft. lbs.).
- (5) Install oil drain plug tighten to 79 N·m (58 ft. lbs.).
- (6) Lower vehicle.
- (7) Fill engine with proper amount of oil.
- (8) Connect battery cable.

REMOVAL AND INSTALLATION (Continued)**OIL PUMP****REMOVAL**

- (1) Remove front cover, (refer to front cover removal in this section).
- (2) Remove oil pump (Fig. 34).



80ae8458

Fig. 34 Oil Pump Removal**INSTALLATION**

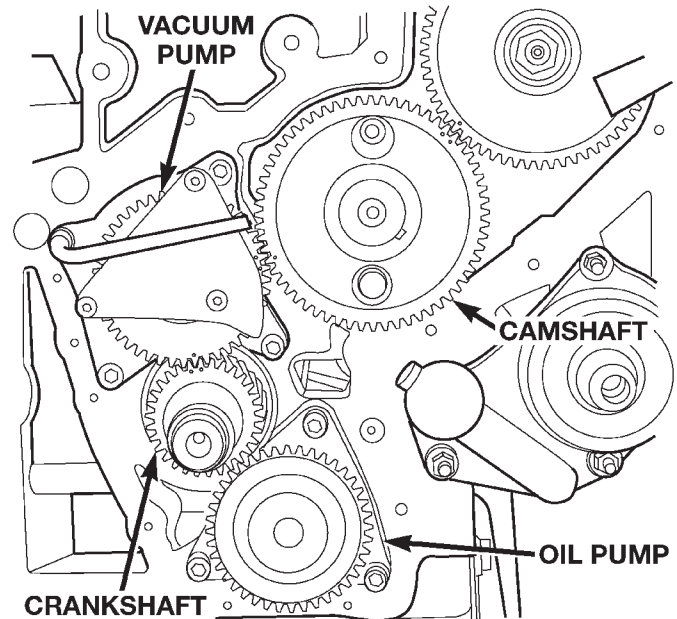
- (1) Install new O-ring and lubricate with clean engine oil.
- (2) Install oil pump and tighten retaining screws to 24.5-29.9 N·m (22.7-28.3 ft. lbs.). Check for normal backlash between pump and crankshaft gears.
- (3) Install front cover, refer to front cover installation in this section.

INTERNAL VACUUM PUMP**REMOVAL**

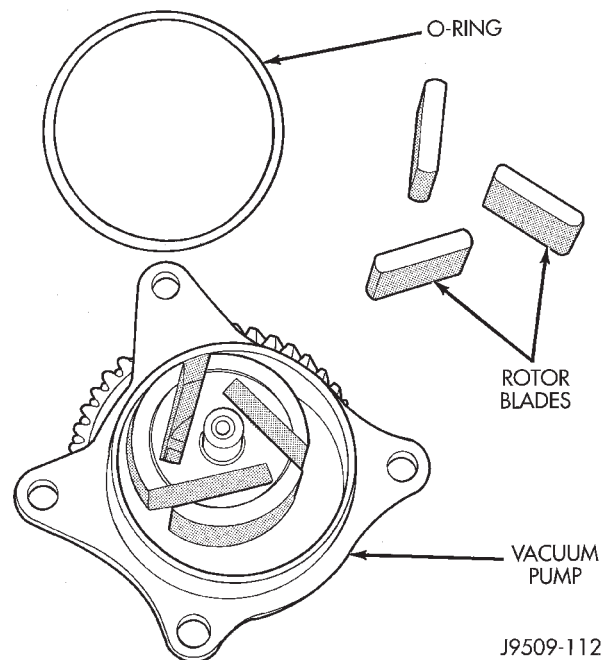
- (1) Remove the front cover refer to front cover removal in this section.
- (2) Remove 4 bolts.
- (3) Remove internal vacuum pump. Vacuum gear has a spring-loaded friction wheel which eliminates backlash and thus reduces running noise. This braces the two wheels against one another and offsets the teeth so that the backlash is eliminated between the meshing gears.

INSTALLATION

- (1) To install the vacuum pump, align the outer part of the gear with the inner part using a screwdriver or similar tool, align with timing marks on gear set and install.



80ae8473

Fig. 35 Vacuum Pump

J9509-112

Fig. 36 Vacuum Pump Parts

- (2) Install bolts and tighten to 20 N·m (15 ft. lbs.).
- (3) Install front cover.

OIL PUMP PRESSURE RELIEF VALVE**REMOVAL**

- (1) Remove oil pan.
- (2) Remove clip retaining relief valve.
- (3) Remove relief valve cap, spring, and plunger (Fig. 39).

REMOVAL AND INSTALLATION (Continued)

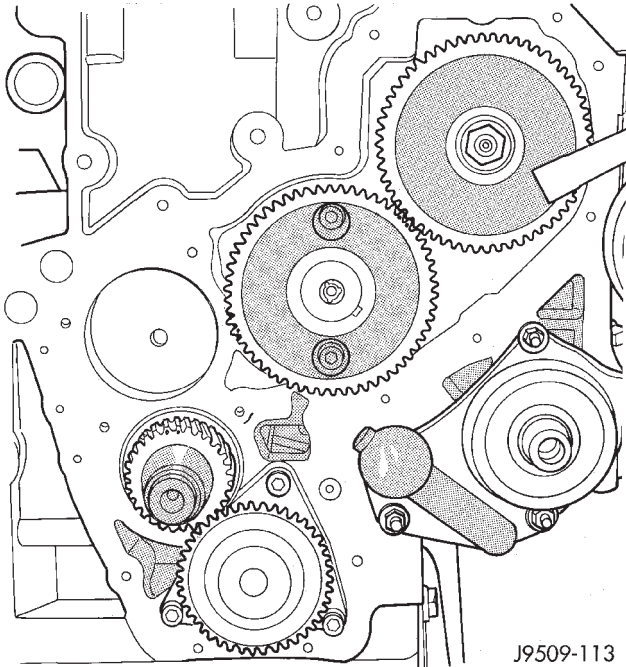


Fig. 37 Vacuum Pump Mounting Hole

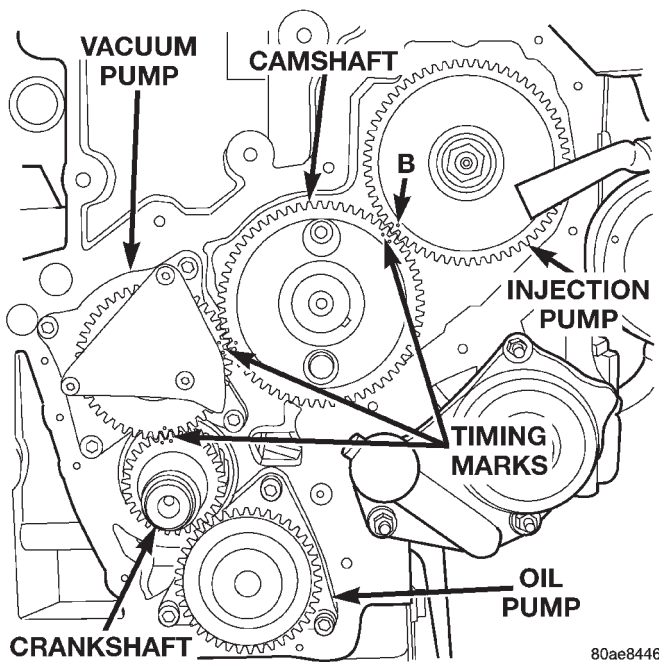


Fig. 38 Timing Marks

(4) Check relief valve spring length. Relief valve spring free length is 57.5mm (2.263 in.). If spring length is less or spring is distorted it must be replaced.

(5) Check plunger for scoring, replace if necessary.

INSTALLATION

(1) Thoroughly clean all components and relief valve pocket in cylinder block.

(2) Fit plunger, spring and cap into block.

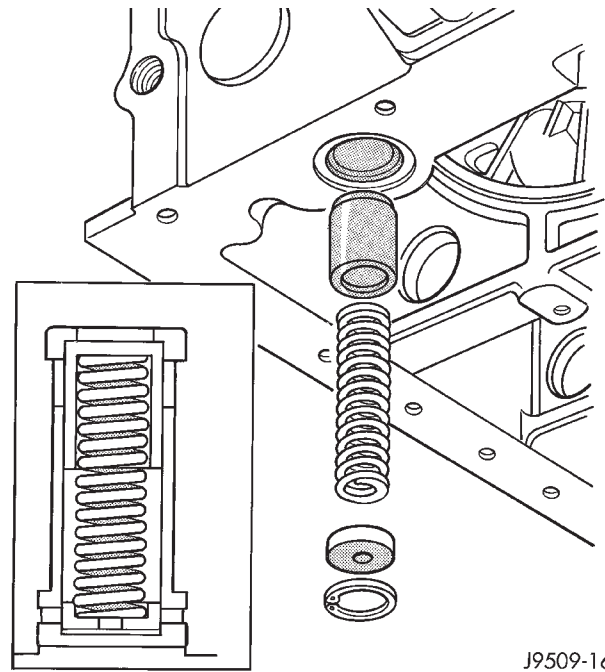


Fig. 39 Oil Pressure Relief Valve

(3) Compress spring and install retaining clip. Ensure clip is completely seated in groove.

OIL FILTER ADAPTER

REMOVAL

- (1) Remove oil filter.
- (2) Remove oil filter adapter with socket wrench.
- (3) Remove oil filter base, allen bolt in center of adapter.
- (4) Remove oil cooler adapter bolt.
- (5) Remove oil cooler (Fig. 40).

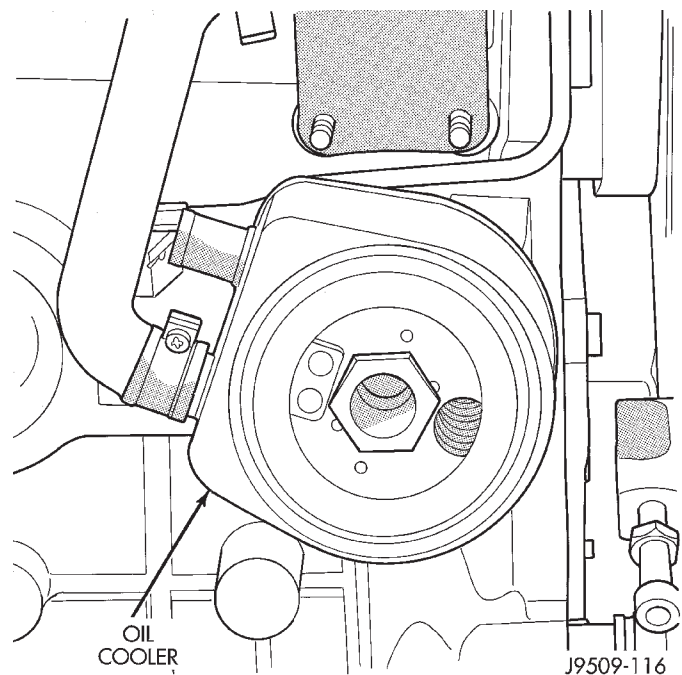


Fig. 40 Oil Cooler

REMOVAL AND INSTALLATION (Continued)

INSTALLATION

- (1) Install oil cooler with new gasket, tighten oil cooler adapter bolt to 60 N·m (44 ft. lbs.).
- (2) Install oil filter base with new o-ring and tighten bolt to 46.6 N·m (34 ft. lbs.).
- (3) Install oil filter adapter to oil filter base and tighten to 46.6 N·m (34 ft. lbs.).
- (4) Install oil filter and tighten to 18 N·m (13 ft. lbs.) and add oil.

PISTONS AND CONNECTING ROD ASSEMBLY

REMOVAL

- (1) Disconnect the battery cable.
- (2) Remove cylinder heads, refer to cylinder head removal in this section.
- (3) Raise vehicle on host.
- (4) Remove oil pan, refer to oil pan removal in this section.
- (5) Remove top ridge of cylinder bores with a reliable ridge reamer before removing pistons from cylinder block. **Be sure to keep tops of pistons covered during this operation**. Mark piston with matching cylinder number.
- (6) Pistons and connecting rods must be removed from top of cylinder block. Rotate crankshaft so that each connecting rod is centered in cylinder bore.
- (7) Remove connecting rod cap. Install connecting rod bolt protectors on connecting rod bolts. Push each piston and rod assembly out of cylinder bore.

NOTE: Be careful not to nick crankshaft journals.

- (8) After removal, install bearing cap on the mating rod.

PISTON PIN—REMOVAL

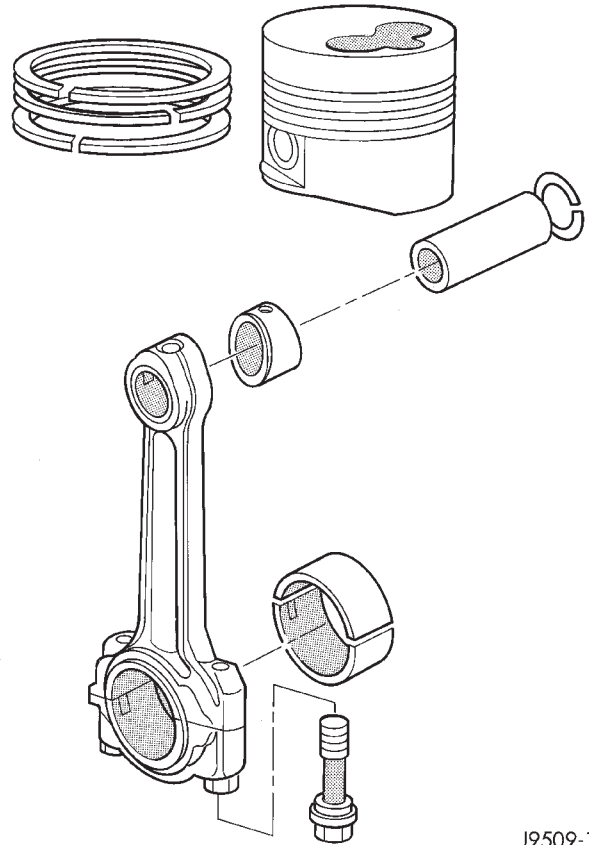
- (1) Secure connecting rod in a soft jawed vice.
- (2) Remove 2 clips securing piston pin.
- (3) Push piston pin out of piston and connecting rod.

PISTON RING—REMOVAL

- (1) ID mark on face of upper and intermediate piston rings must point toward piston crown.
- (2) Using a suitable ring expander, remove upper and intermediate piston rings (Fig. 42).
- (3) Remove the upper oil ring side rail, lower oil ring side rail and then oil ring expander from piston.
- (4) Carefully clean carbon from piston crowns, skirts and ring grooves ensuring the 4 oil holes in the oil control ring groove are clear.

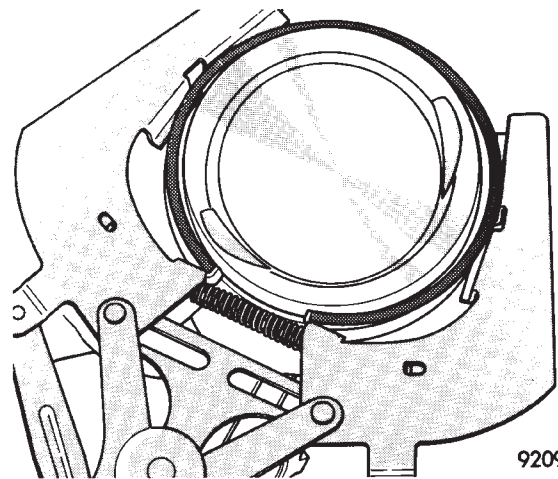
PISTON RING FITTING

- (1) Wipe cylinder bore clean. Insert ring and push down with piston to ensure it is square in bore. The ring gap measurement must be made with the ring



J9509-172

Fig. 41 Piston Assembly



9209-16

Fig. 42 Piston Rings—Removing and Installing

positioning at least 12 mm (0.50 in.) from bottom of cylinder bore. Check gap with feeler gauge. Top compression ring gap .25 to .50mm (.0098 to .0196 in.). Second compression ring gap .25 to .35mm (.0098 to .0137 in.). Oil control ring gap .25 to .58mm (.0098 to .0228 in.).

- (2) If ring gaps exceed dimension given, new rings or cylinder liners must be fitted. Keep piston rings in piston sets.

REMOVAL AND INSTALLATION (Continued)

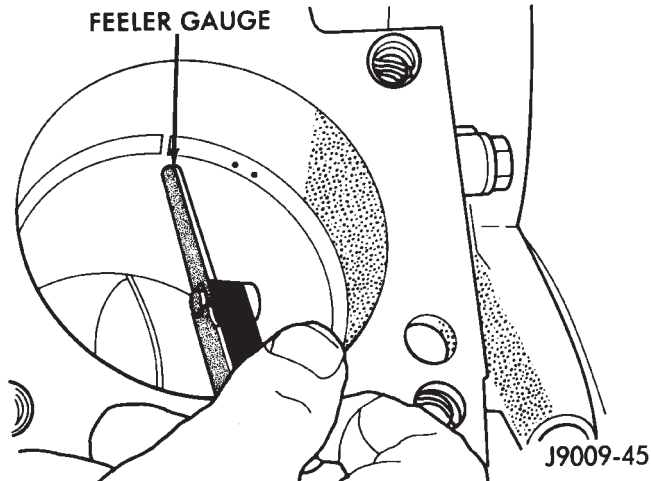


Fig. 43 Ring Gap Measurement

(3) Check piston ring to groove clearance. Top compression ring gap .08 to .130mm (.0031 to .0051 in.). Second compression ring gap .070 to .102mm (.0027 to .0040 in.). Oil control ring gap .040 to .072mm (.0015 to .0028 in.).

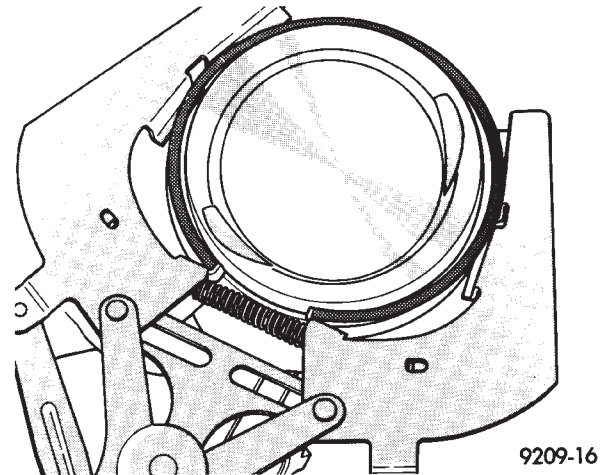


Fig. 45 Piston Rings—Removing and Installing

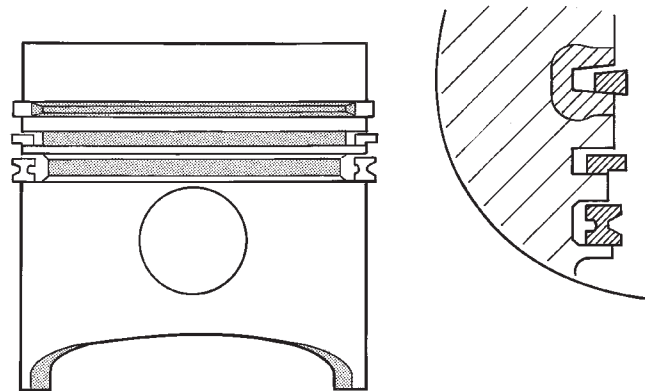


Fig. 46 Piston Ring Identification

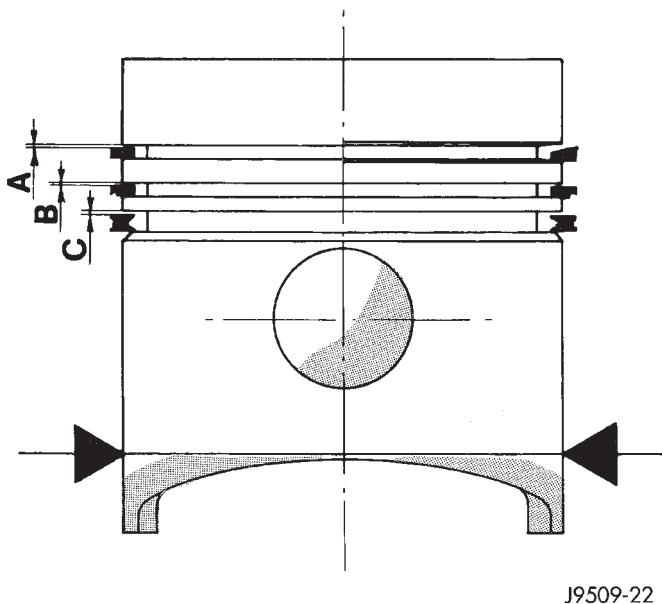


Fig. 44 Piston Ring Side Clearance

PISTON RINGS—INSTALLATION

(1) Install rings on the pistons using a suitable ring expander (Fig. 45).

(2) Top compression ring is tapered and chromium plated. The second ring is of the scraper type and must be installed with scraping edge facing bottom of the piston. The third is an oil control ring. Ring gaps must be positioned, before inserting piston into the liners, as follows (Fig. 47).

(3) Top ring gap must be positioned at 30 degrees to the right of the combustion chamber recess (looking at the piston crown from above).

(4) Second piston ring gap should be positioned on the opposite side of the combustion chamber recess.

(5) Oil control ring gap to be located 30 degrees to the left of combustion chamber recess.

(6) When assembling pistons check that components are installed in the same position as before disassembly, determined by the numbers stamped on the crown of individual pistons. Engine cylinders are numbered starting from gear train end of the engine. **Face chamber recess side of piston towards camshaft**. Therefore, the numbers stamped on con rod big end should also face in the same direction. To insert piston into cylinder use a ring compressor as shown in (Fig. 45).

PISTON PIN INSTALLATION

- (1) Secure connecting rod in soft jawed vice.
- (2) Lubricate piston pin and piston with clean oil.
- (3) Position piston on connecting rod.

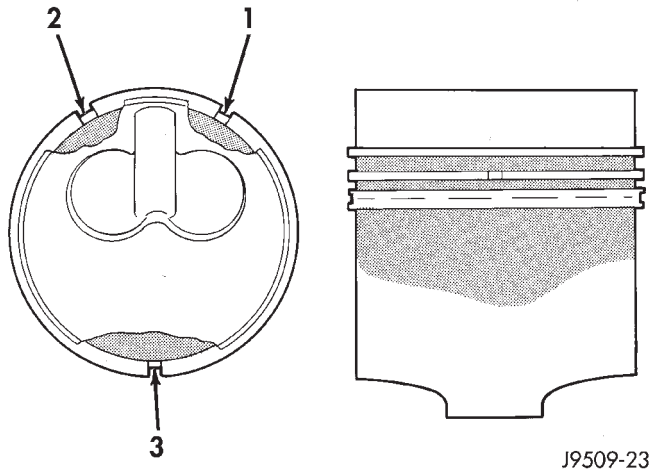
REMOVAL AND INSTALLATION (Continued)

CAUTION: Ensure combustion recess in piston crown and the bearing cap numbers on the connecting rod are on the same side.

- (4) Install piston pin.
- (5) Install clips in piston to retain piston pin.
- (6) Remove connecting rod from vice.

INSTALLATION

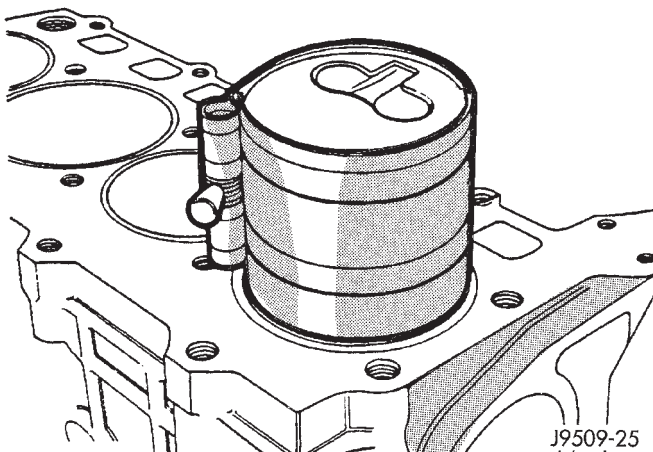
(1) Before installing pistons, and connecting rod assemblies into the bore, be sure that compression ring gaps are staggered so that neither is in line with oil ring rail gap (Fig. 47).



J9509-23

Fig. 47 Piston Ring Gap Location

(2) Before installing the ring compressor, make sure the oil ring expander ends are butted and the rail gaps located as shown in (Fig. 47).



J9509-25

Fig. 48 Installing Piston

(3) Immerse the piston head and rings in clean engine oil, slide the ring compressor, over the piston and tighten with the special wrench (Fig. 48). **Ensure position of rings does not change during this operation.**

(4) Face chamber recess side of piston towards camshaft.

(5) Install connecting rod bolt protectors on rod bolts.

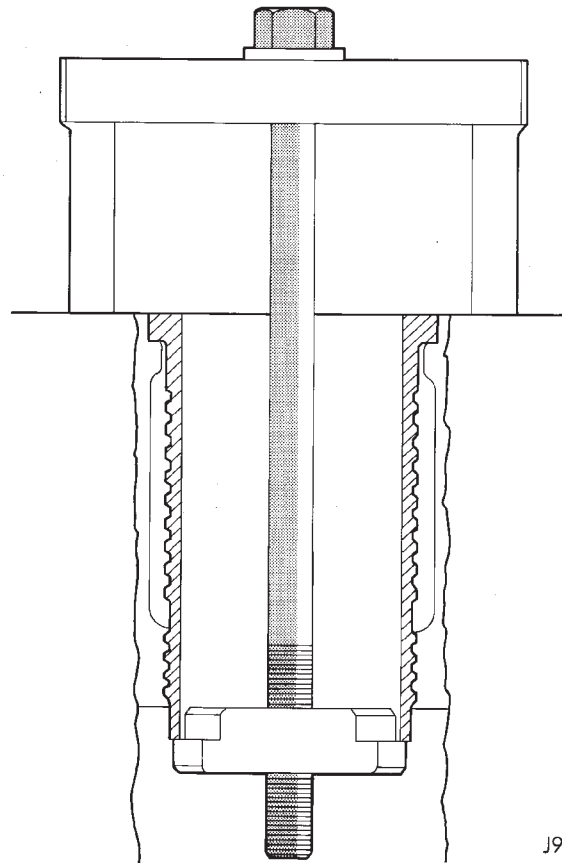
(6) Rotate crankshaft so that the connecting rod journal is on the center of the cylinder bore. Insert rod and piston into cylinder bore and guide rod over the crankshaft journal.

(7) Tap the piston down in cylinder bore, using a hammer handle. At the same time, guide connecting rod into position on connecting rod journal.

(8) Install rod caps. Install nuts on cleaned and oiled rod bolts and tighten nuts to 29.5 N-m (22 ft. lb.) plus 60°.

CYLINDER WALL LINER ASSEMBLY**REMOVAL**

- (1) Remove cylinder heads.
- (2) Remove Oil pan.
- (3) Remove pistons.
- (4) Use tool VM-1001 to remove liners (Fig. 49).

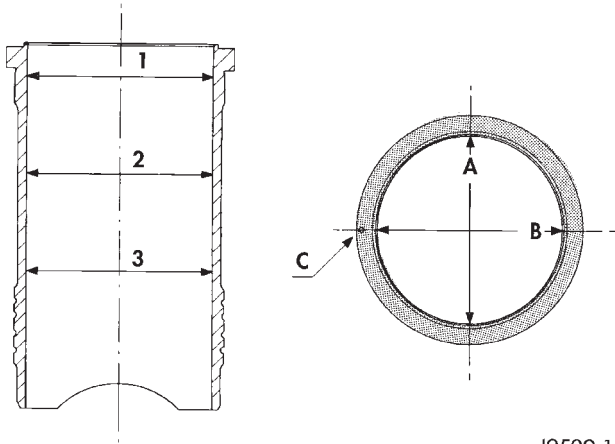


J9509-12

Fig. 49 Liner Removal Tool

(5) Remove shims from cylinder liner or cylinder block recess. Keep shims with each cylinder liner.

REMOVAL AND INSTALLATION (Continued)



J9509-13

Fig. 50 Liner Inspection

INSTALLATION

(1) Carefully clean residual LOCTITE from liner and crankcase, and degrease the crankcase where it

comes into contact with the liners. Install the liners in the crankcase as shown (A), rotating them back and forth by 45° in order to guarantee correct positioning (Fig. 51).

(2) Measure the liner recess relative to block deck with a dial indicator mounted on a special tool VM-1010 A. **All the measurements must be taken on camshaft side**. Zero dial gauge on block deck.

(3) Move dial gauge to cylinder liner record reading on dial gauge.

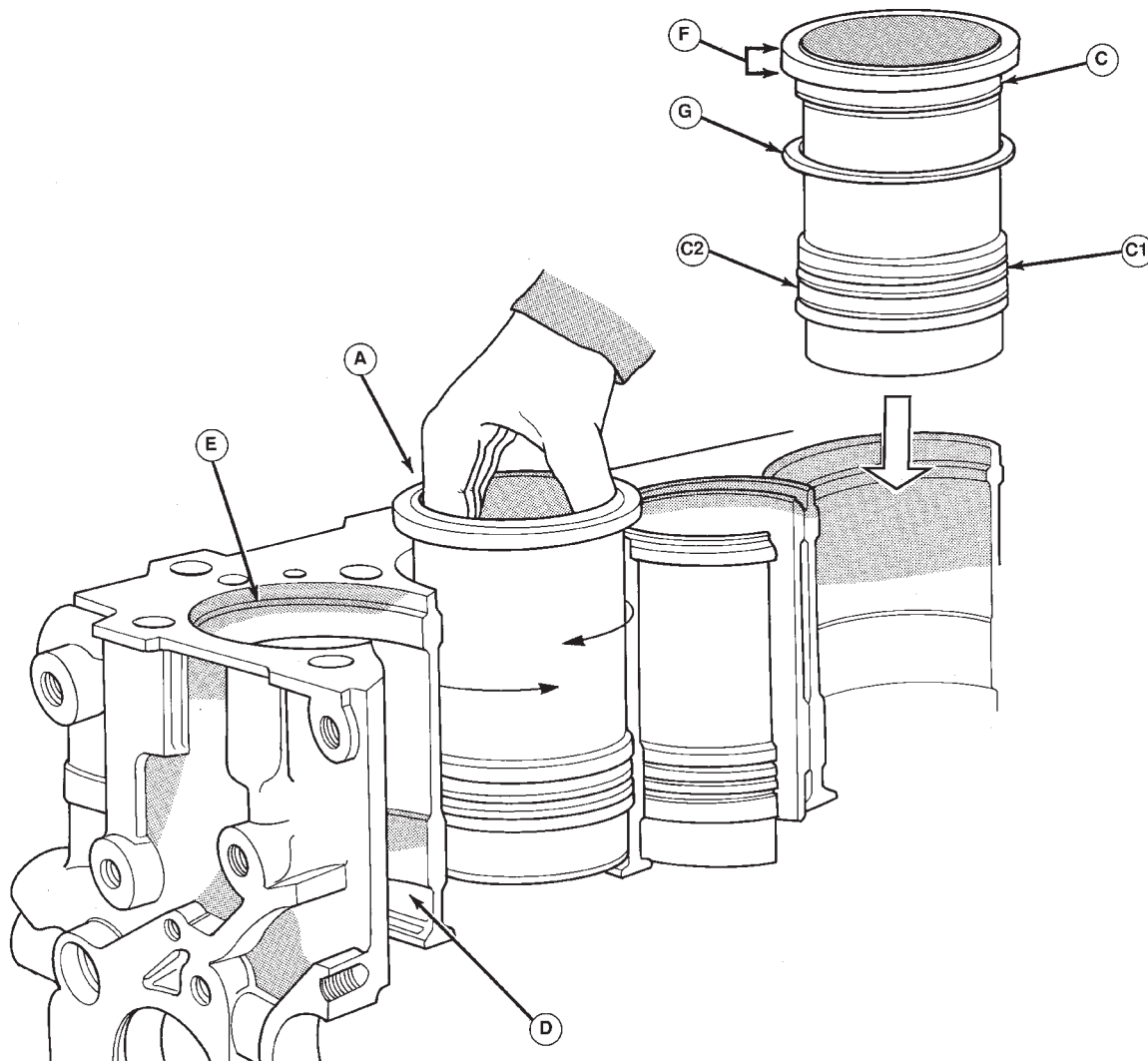
(4) Remove liner and special tool.

(5) Then select the correct shim thickness to give proper protrusion (0.01 - 0.06 mm).

(6) Fit the shim and the O-rings onto the liner.

(7) Lubricate the lower liner location in the block. Apply LOCTITE AVX to the corner of the liner seat. Apply LOCTITE AVX uniformly to the upper part of the liner at area.

(8) Fit the liners in the crankcase making sure that the shim is positioned correctly in the seat. Lock



J9509-120

Fig. 51 Liner Installation

REMOVAL AND INSTALLATION (Continued)

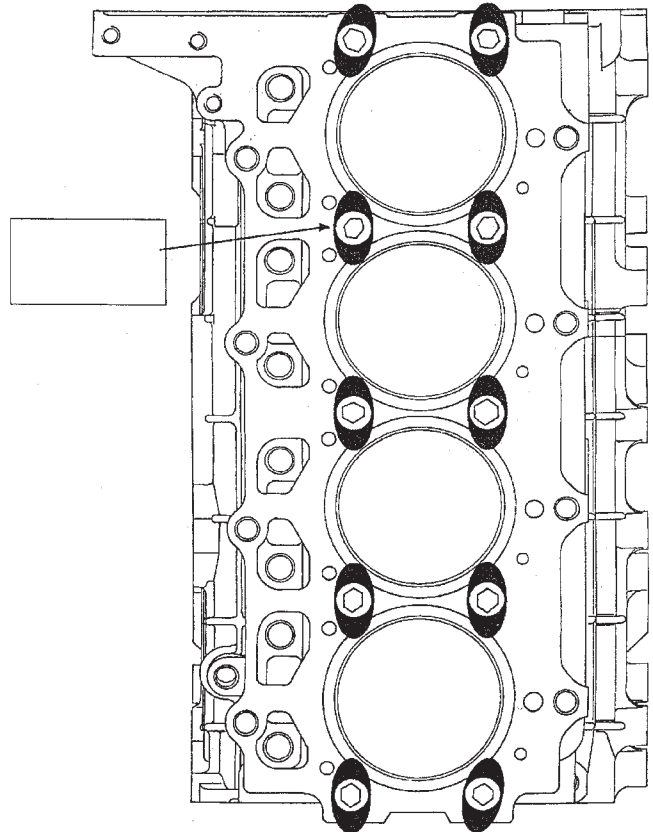
the liners in position using special tool (VM-1016) and bolts (Fig. 52). Clean the residual LOCTITE on the upper surface of the block deck.

(9) Recheck the liner protrusion. It should be 0.01 - 0.06 mm.

NOTE: A period of six hours must elapse between the liners being installed and engine start-up. If engine assembly is not continued after liner installation, the liners need to be clamped for twelve hours minimum.

CRANKSHAFT MAIN BEARINGS**REMOVAL**

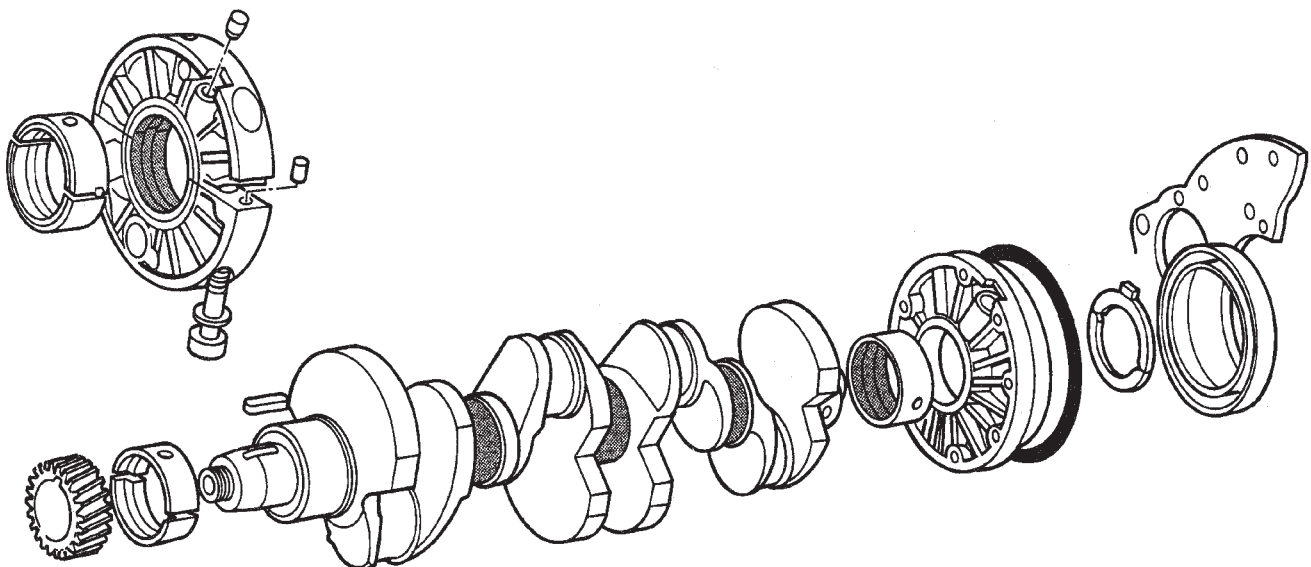
- (1) Disconnect battery cable.
- (2) Remove engine from vehicle, refer to engine removal in this section.
- (3) Install engine to engine stand.
- (4) Remove accessory drive system.
- (5) Remove cylinder head cover, refer to cylinder head cover removal in this section.
- (6) Remove rocker arm and push rods, refer to rocker arm and push rod section in this section.
- (7) Remove intake, exhaust manifold and turbo-charger, refer to Group 11, Exhaust System and Intake Manifold.
- (8) Remove water manifold.
- (9) Remove oil feed lines to rocker arms.
- (10) Remove cylinder heads.
- (11) Remove oil pan and oil pick-up.
- (12) Remove piston and connecting rods from crankshaft journals.
- (13) Remove pistons and connecting rods from block.



VM920970

Fig. 52 Liner Clamp Location

- (14) Remove vibration damper, refer to vibration damper removal in this section.
- (15) Remove front cover, refer to front cover removal in this section.
- (16) Remove oil pump and vacuum pump from block.



J9509-178

Fig. 53 Crankshaft and Bearing Assembly

REMOVAL AND INSTALLATION (Continued)

(17) Install special tool VM-1004 onto crankshaft over gear (Fig. 54).

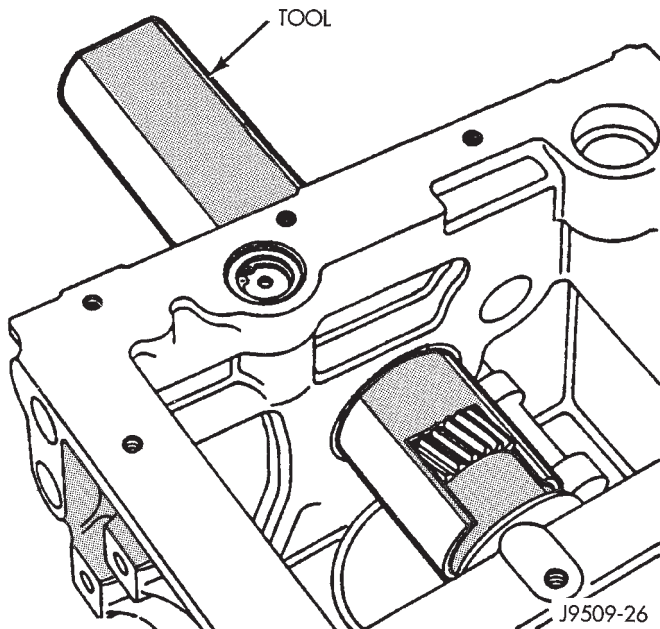


Fig. 54 Crankshaft Special Tool VM-1004

(18) Remove main bearing oil feed and carrier locators from block.

(19) Remove flywheel and adaptor plate from engine block.

(20) Remove thrust bearings from rear main bearing carrier.

(21) Slide crankshaft and bearing carriers rearward to rear of block. If you encounter difficulty in removing the complete assembly as previously described, slide the assembly rearward sufficiently to gain access to the main bearing carrier bolts. Mark the carriers for assembly and remove the bolts, two for each carrier (Fig. 55).

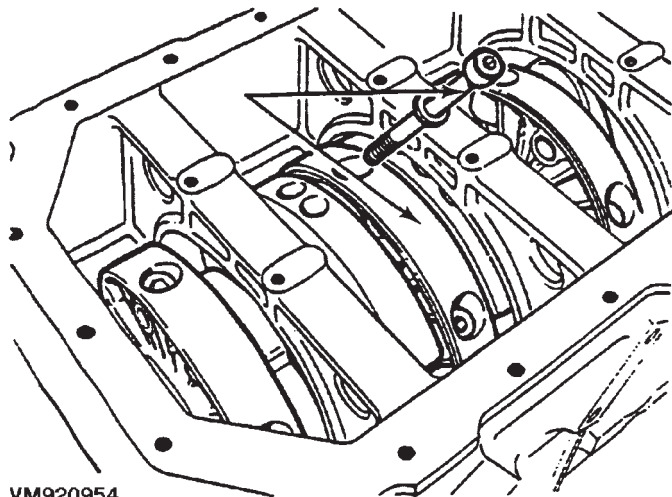


Fig. 55 Carrier Bolts

(22) Separate the two halves of each carrier, remove from the crankshaft and temporarily re-assemble the carriers (Fig. 56). Withdraw the crankshaft through the rear of the crankcase.

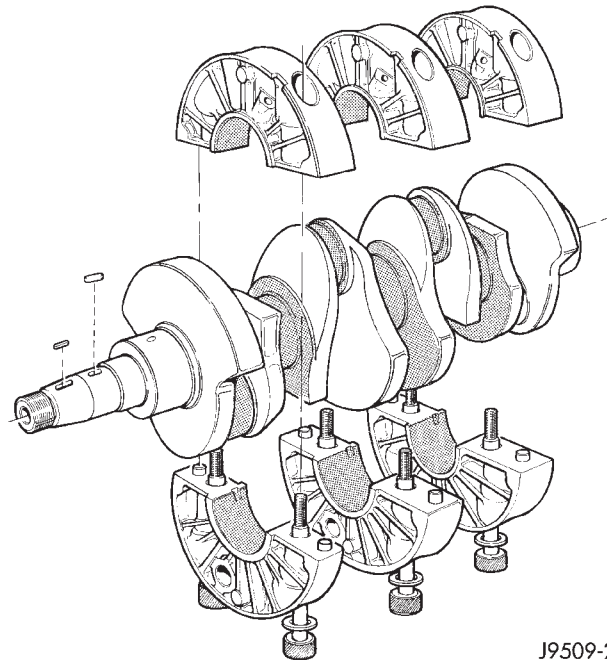


Fig. 56 Crankshaft and Carrier Bearing Assembly

INSTALLATION

(1) Fit main bearing carriers together and torque to 42 N·m (31 ft. lbs.).

(2) Check internal diameter of bearings.

(3) If internal diameter of original bearing is being checked and figures are not within specifications, new bearings must be used.

(4) Check crankshaft main bearing journals to bearing clearances. Clearances of main bearings is .03 to .088mm (.0011 to .0035 in.).

NOTE: Assemble engine according to sequence described, thus saving time and preventing damages to engine components. Clean parts with a suitable solvent and dry them with compressed air before assembly. Use new gaskets where applicable and torque wrenches for correct tightening of components.

(5) Thoroughly clean crankcase and oil passages, and blow dry with compressed air.

(6) Install new main bearing shells in each of the carrier halves. Assemble the carriers to the crankshaft journals, ensuring that the carriers are installed in their original locations and that the **piston jet notch is towards the front of the crankshaft**. Secure each carrier with the two bolts tightening evenly to 42 N·m (31 ft. lbs.). Check that the oil jet is in position (Fig. 56).

REMOVAL AND INSTALLATION (Continued)

(7) Slide special tool (VM-1002) over the crankshaft gear and, insert the crankshaft and carrier assembly into the crankcase in the same manner used for removal.

(8) Align the holes in the lower carriers, with the center of the crankcase webs (Fig. 57).

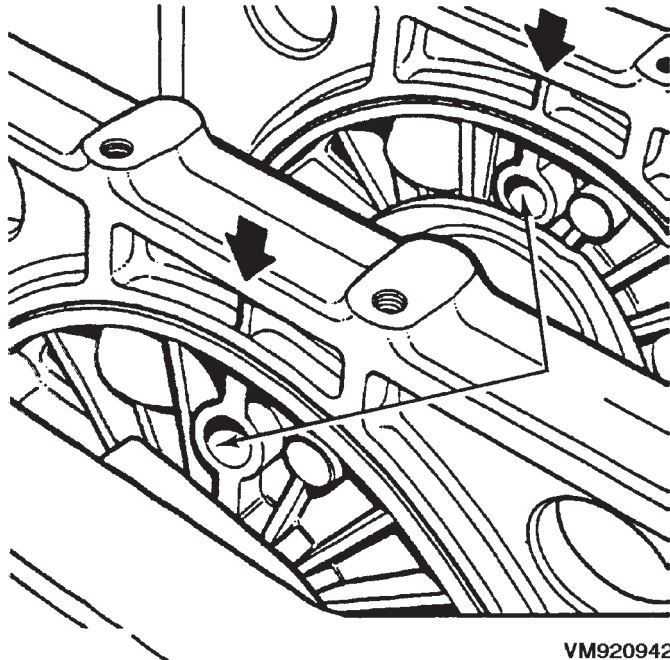


Fig. 57 Main Bearing Carrier Alignment

(9) Secure each carrier assembly to the crankcase with the main bearing oil feed and carrier locators and tighten them to 54 N·m (40 ft. lbs).

(10) Install rear main bearing carrier onto crankshaft ensuring arrow on bearing carrier aligns with vertical web in center of crankcase.

(11) Install rear oil seal.

(12) Install new O-rings in adaptor plate.

(13) Install adaptor plate to block and tighten nuts to 26.5 N·m (20 ft. lbs.).

(14) Install Allen bolts through adaptor plate to rear main bearing carrier and tighten to 11 N·m (97 in. lbs.).

(15) Position flywheel and O-ring on crankshaft and align bolt holes.

NOTE: For purposes of checking crankshaft end play, used flywheel bolts may be used. Final assembly requires new flywheel bolts.

(16) Install 2 flywheel bolts, 180° apart, and tighten bolts to 20 N·m plus 60° (15 ft. lbs.) plus 60°.

(17) Attach dial indicator to engine block.

(18) Move crankshaft toward front of engine and zero indicator.

(19) Move crankshaft toward the rear of engine and record measurement.

(20) Subtract specified crankshaft end play from figure obtained. Crankshaft end play .153 to .304mm (.0060 to .0119 in.).

(21) Select thrust washers which will give correct end play.

(22) Remove tools and flywheel.

(23) Lubricate thrust washer halves and fit them into the rear main bearing carrier.

(24) Ensure that crankshaft end and flywheel mating surfaces are clean and dry. Install "O" ring in flywheel groove.

(25) To verify correct end play, install 2 flywheel bolts 180° apart, and tighten bolts to 20 N·m plus 60° (15 ft. lbs. plus 60°).

(26) Measure crankshaft end play with a dial gauge. Crankshaft end play should not exceed .153 to .304mm (.0060 to .0119 in.) (Fig. 58).

(27) Mount flywheel on crankshaft. Lightly oil and install NEW bolts, tightening to 20 N·m in diametrically opposite pairs. Check that all bolts are at 20 N·m. Tighten each bolt a further 60° +0-5°, tightening bolts in diametral pairs. Check that all bolts are tightened to 130 N·m.

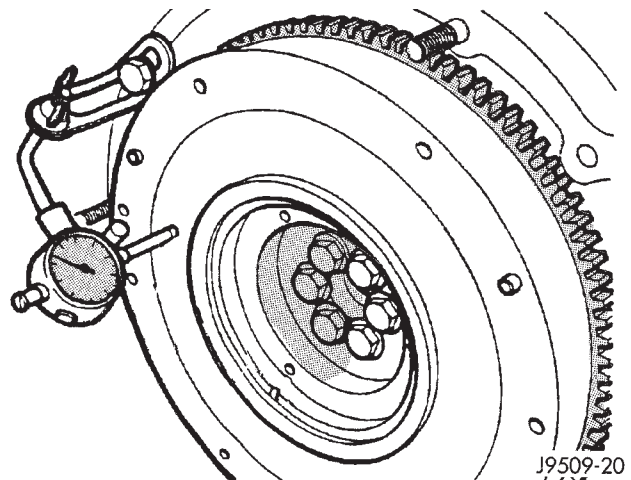


Fig. 58 Measuring Crankshaft End Play

(28) Install pistons and connecting rod assemblies, refer to piston and connecting rods in this section.

(29) Install oil pick up tube and tighten bolts to 25 N·m (18 ft. lbs.).

(30) Install oil pan, refer to oil pan installation in this section.

(31) Install vacuum pump, being careful to align the gear timing marks with those on the crankshaft gear. Tighten retaining screws to 20 N·m (15 ft. lbs.).

(32) Before installing oil pump check pump bore depth in block (A) and pump body height (B) (Fig. 59). Difference between A and B should be 0.020-0.082 mm (.0007 to .0032 in.).

(33) Install oil pump and tighten retaining screws to 27 N·M (20 ft.lbs.). Check for normal backlash between pump and crankshaft gears.

REMOVAL AND INSTALLATION (Continued)

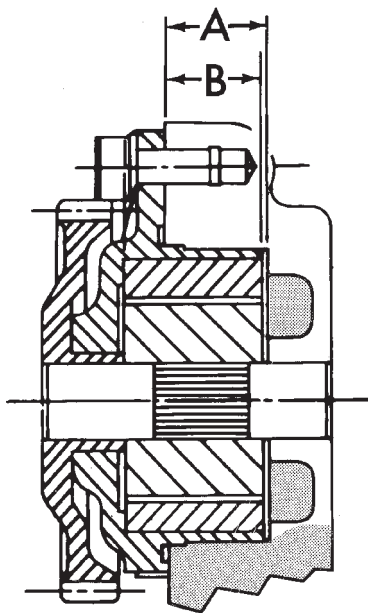


Fig. 59 Oil Pump Bore Depth

- (34) Install front cover, refer to front cover installation in this section.
- (35) Install vibration damper, refer to vibration damper installation in this section.
- (36) Install cylinder heads, refer to cylinder head installation in this section.
- (37) Install rocker arms and push rods, refer to rocker arm and push rod in this section.
- (38) Install cylinder head cover, refer to cylinder head cover in this section.
- (39) Install accessory drive system.
- (40) Install engine in vehicle, refer to engine installation in this section.
- (41) Fill engine with the correct amount of fluids specified.
- (42) Connect battery cable.

DISASSEMBLY AND ASSEMBLY

HYDRAULIC TAPPETS

DISASSEMBLE

- (1) Pry out plunger retainer spring clip.
- (2) Clean varnish deposits from inside of tappet body above plunger cap.
- (3) Invert tappet body and remove plunger cap, plunger, check valve, check valve spring, check valve retainer and plunger spring. Check valve could be flat or ball.

ASSEMBLE

- (1) Clean all tappet parts in a solvent that will remove all varnish and carbon.

(2) Replace tappets that are unfit for further service with new assemblies.

(3) If plunger shows signs of scoring or wear, install a new tappet assembly. If valve is pitted, or valve seat on end of plunger is prevented from seating, install a new tappet assembly.

(4) Assemble tappets.

CLEANING AND INSPECTION

CYLINDER HEAD

CLEANING

Thoroughly clean the engine cylinder head and cylinder block mating surfaces. Clean the intake and exhaust manifold and engine cylinder head mating surfaces. Remove all gasket material and carbon.

Check to ensure that no coolant or foreign material has fallen into the tappet bore area.

Remove the carbon deposits from the combustion chambers and top of the pistons.

INSPECTION

Use a straightedge and feeler gauge to check the flatness of the engine cylinder head and block mating surfaces (Fig. 60).

Minimum cylinder head thickness 89.95mm (3.541 in.)

CAUTION: If only one cylinder head is found to be distorted and requires machining, it will also be necessary to machine the remaining cylinder heads and end plates by a corresponding amount to maintain correct cylinder alignment.

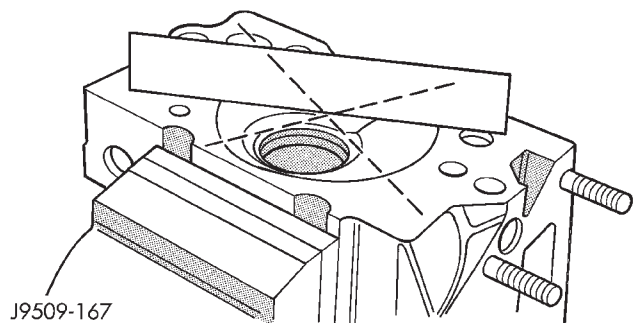


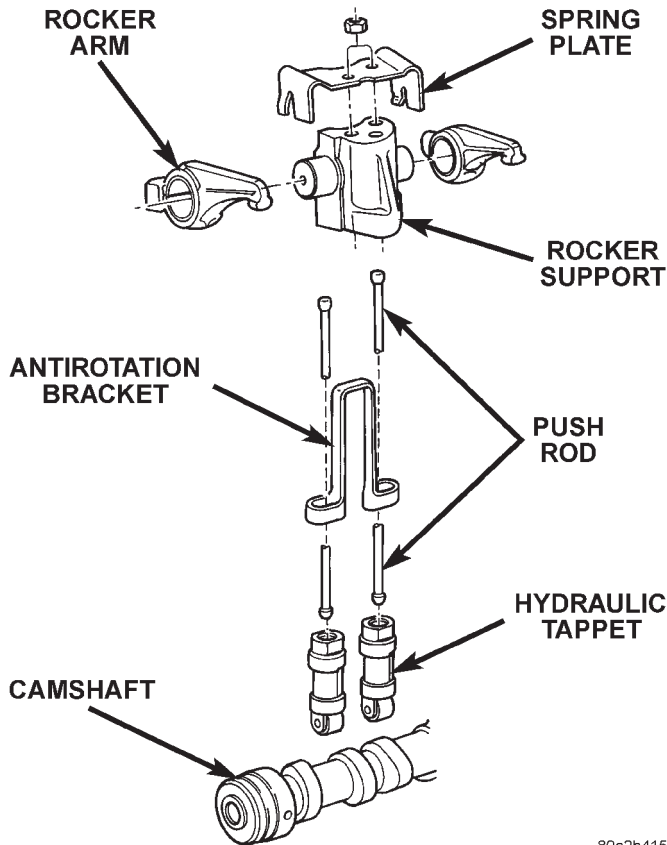
Fig. 60 Checking Cylinder Head Flatness

ROCKER ARMS AND PUSH RODS

CLEANING

Clean all the components (Fig. 61) with cleaning solvent.

Use compressed air to blow out the oil passages in the rocker arms and push rods.

CLEANING AND INSPECTION (Continued)

80a2b415

Fig. 61 Rocker Arm Components**INSPECTION**

Inspect the pivot surface area of each rocker arm. Replace any that are scuffed, pitted, cracked or excessively worn.

Inspect the valve stem tip contact surface of each rocker arm and replace any rocker arm that is deeply pitted.

Inspect each push rod end for excessive wear and replace as required. If any push rod is excessively worn because of lack of oil, replace it and inspect the corresponding hydraulic tappet for excessive wear.

Inspect the push rods for straightness by rolling them on a flat surface or by shining a light between the push rod and the flat surface.

A wear pattern along the length of the push rod is not normal. Inspect the engine cylinder head for obstruction if this condition exists.

PISTONS AND CONNECTING ROD ASSEMBLY**INSPECTION—PISTONS**

(1) Piston Diameter: Size Group A: 91.93-91.94mm (3.6191-3.6196 in.) Size Group B: 91.94-91.95mm (3.6196-3.6200 in.). Maximum wear limit .05mm (.0019 in.).

(2) Check piston pin bores in piston for roundness. Make 3 checks at 120° intervals. Maximum out of roundness .05mm (.0019in.).

(3) The piston diameter should be measured approximately 15 mm (.590 in.) up from the base.

(4) Skirt wear should not exceed 0.1 mm (.00039 in.).

(5) The clearance between the cylinder liner and piston should not exceed 0.25 mm (.0009 in.).

(6) Make sure the weight of the pistons does not differ by more than 5 g.

INSPECTION—CONNECTING ROD

(1) Assemble bearing shells and bearing caps to their respective connecting rods ensuring that the serrations on the cap and reference marks are aligned.

(2) Tighten bearing cap bolts to 29N·m (21 ft. lbs.) plus 60°.

(3) Check and record internal diameter of crank end of connecting rod.

NOTE: When changing connecting rods, all four must have the same weight and be stamped with the same number. Replacement connecting rods will only be supplied in sets of four.

Connecting rods are supplied in sets of four since they all must be of the same weight category. Max allowable weight difference is 18 gr.

NOTE: On one side of the big end of the con-rod there is a two-digit number which refers to the weight category. On the other side of the big end there is a four digit number on both the rod and the cap. These numbers must both face the camshaft as well as the recess on the piston crown (Fig. 63). Lightly heat the piston in oven. Insert piston pin in position and secure it with provided snap rings.

The Four digit numbers marked on con rod big end and rod cap must be on the same side as the camshaft (Fig. 63). After having coated threads with Molyguard, tighten con rod bolts to 29 N·m (21 ft. lbs.) plus 60°.

INSPECTION—PISTON PIN

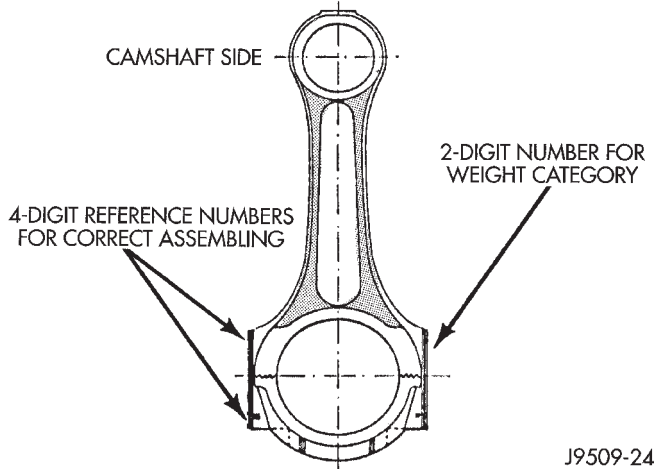
(1) Measure the diameter of piston pin in the center and both ends.

(2) Piston pin diameter is 29.990 to 29.996mm (1.1807 to 1.1809 in.).

INSPECTION—CRANKSHAFT JOURNALS

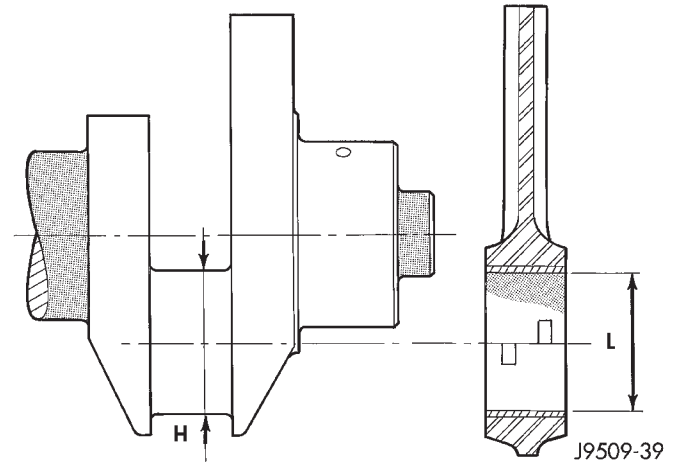
(1) Using a micrometer, measure and record crankshaft connecting rod journals, take reading of each journal 120° apart. Crankshaft journal diameter is 53.84 to 53.955mm (2.1196 to 2.1242 in.).

CLEANING AND INSPECTION (Continued)



J9509-24

Fig. 62 Connecting Rod Identification



J9509-39

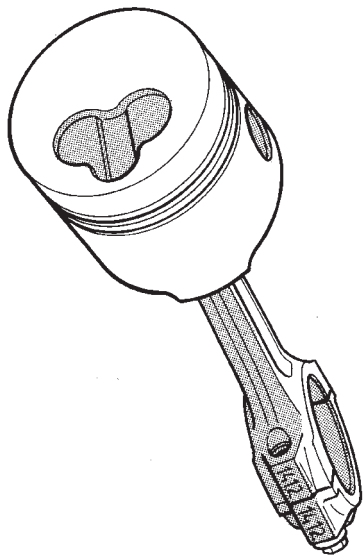
Fig. 64 Bearing Clearance

CYLINDER WALL LINER ASSEMBLY

INSPECTION

The cylinder walls should be checked for out-of-round and taper with dial bore gauge. The cylinder bore out-of-round is 0.100 mm (.0039 inch) maximum and cylinder bore taper is 0.100 mm (0.0039 inch) maximum. If the cylinder walls are badly scuffed or scored, new liners should be installed and honed, and new pistons and rings fitted.

Measure the cylinder bore at three levels in directions A and B (Fig. 65). Top measurement should be 10 mm (3/8 inch) down and bottom measurement should be 10 mm (3/8 inch.) up from bottom of bore.



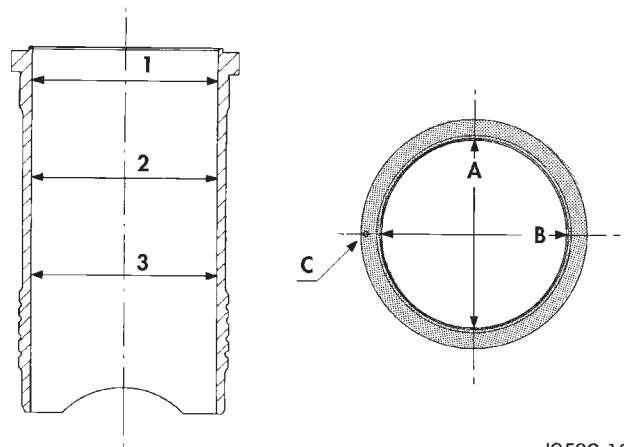
J9509-21

Fig. 63 Piston and Connecting Rod Assembly

(2) Crankshaft journals worn beyond limits or show signs of out of roundness must be reground or replaced. Minimum reground diameter is 53.69mm (2.1137 in.).

BEARING-TO-JOURNAL CLEARANCE

Compare internal diameters of connecting rod with crankshaft journal diameter. Maximum clearance between connecting rod and crankshaft journals .022 to .076mm (.0008 to .0029 in.).



J9509-13

Fig. 65 Liner Inspection

CLEANING AND INSPECTION (Continued)

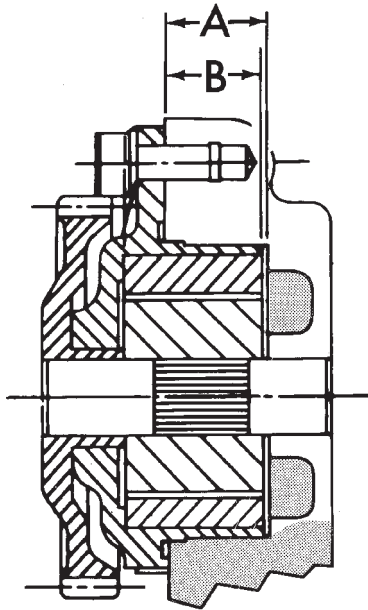
OIL PUMP

CLEANING

Wash all parts in a suitable solvent and inspect carefully for damage or wear.

INSPECTION

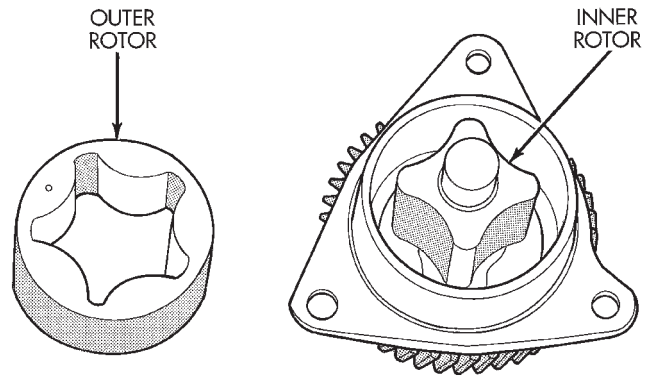
(1) Before installing oil pump check pump bore depth in block (A) and pump body height (B) (Fig. 66). Difference between A and B should be 0.020-0.082 mm.



J9509-8

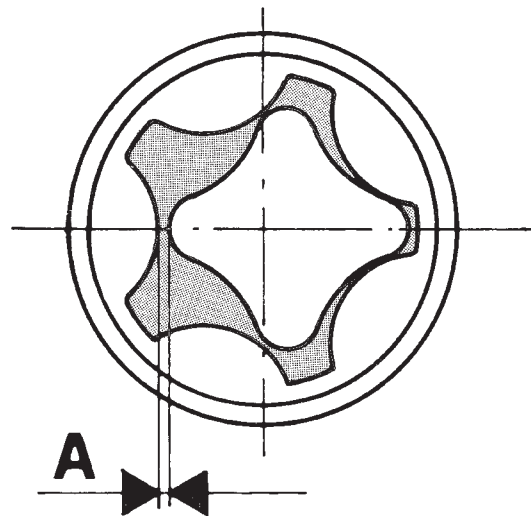
Fig. 66 Oil Pump Bore Depth

(2) Check clearance between rotors (Fig. 68).



J9509-109

Fig. 67 Oil Pump Inner and Outer Rotors



J9509-10

Fig. 68 Checking Rotor Clearance

SPECIFICATIONS

ENGINE SPECIFICATIONS

Description	Specifications
Type	425CLIRX (23B)
Number of cylinders	4
Bore	92 mm
Stroke	94 mm
Capacity	2499.5 cm ³
Injection order	1-3-4-2
Compression ratio21 : 1 (+/- 0.5)
Gasket	Asbestos free

Crankshaft

Front journal diameter	
Nominal	62.985-63.000 mm
-0.25	62.745-62.760 mm
-0.125	62.860-62.875 mm
Front bearing diameter	
Nominal	63.043-63.088 mm
-0.25	62.810-62.860 mm
-0.125	62.918-62.963 mm
Clearance between journal and bearing:	0.043-0.103
Center journal diameter	
Nominal	63.005-63.020 mm
-0.25	62.755-62.770 mm
-0.125	62.880-62.895 mm
Center bearing diameter	
Nominal	63.050-63.093 mm
-0.25	62.800-62.843 mm
-0.125	63.550-62.968 mm
Clearance between journal and bearing:	0.030-0.088
Rear journal diameter	
Nominal	69.980-70.000 mm
-0.25	69.735-69.750 mm
-0.125	69.855-69.875 mm
Rear bearing diameter	
Nominal	70.030-70.055 mm
-0.25	69.780-69.805 mm
-0.125	69.905-69.980 mm
Clearance between journal and bearing:	0.030-0.075
Wear limit:	0.200 mm.
Connecting rod journal	
Nominal	53.940-53.955 mm
-0.25	53.690-53.705 mm
-0.125	53.815-53.830 mm
Connecting rod bearing	
Nominal	53.977-54.016 mm
-0.25	53.727-53.766 mm
-0.125	53.852-53.891 mm
Clearance between journal and bearing:	0.022-0.076
Wear limit:	0.200 mm

Description	Specifications
Crankshaft end play	
End play	0.153-0.304 mm
Adjustment	Thrust washers
Thrust washers available:	
	2.311-2.362 mm
	2.411-2.462 mm
	2.511-2.562 mm

Main bearing carriers

Internal diameter	
Front	67.025-67.050 mm
Center	66.670-66.687 mm
Rear	75.005-75.030 mm

Liners

Internal diameter	92.000-92.010 mm
Protrusion	0.01-0.06 mm
Adjustment	Shims
Available shims:	
	0.15 mm
	0.17 mm
	0.20 mm
	0.23 mm
	0.25 mm

Cylinder head

Minimum thickness	89.95-90.05 mm
Gaskets thickness:	
	1.42 mm +/- 0.04, 0 notches
	1.62 mm +/- 0.04, 1 notches
	1.52 mm +/- 0.04, 2 notches
End plates:	
Height	91.26-91.34 mm

Connecting rods

Weight (without the crank bearing):	1129-1195 grams
Small end bearing	
Internal diameter	
Minimum	30.035 mm
Maximum	30.050 mm
Crankshaft bearings	
Standard Internal diameter	53.977-54.016 mm

Pistons

Skirt diameter	91.935-91.945 mm
(measured at approximately 15 mm above the bottom of the skirt).	
Piston clearance:	
Top of piston to cylinder head	0.055-0.075 mm
Piston protrusion	0.80-0.89 mm
	0.53 - 0.62 Fit gasket
	Number (1.42), 0 notches
	0.73 - 0.82 Fit gasket
	Number (1.62), 1 notches
	0.63 - 0.72 Fit gasket
	Number (1.52), 2 notches

SPECIFICATIONS (Continued)

Description	Specifications
Piston pins	
Type.....	Fully floating
Pin diameter.....	29.990-29.996 mm
Clearance.....	0.039-0.060 mm
Piston rings	
Clearance in groove:	
Top.....	0.080-0.130 mm
Second.....	0.070-0.102 mm
Oil control.....	0.040-0.072 mm
Fitted gap:	
Top.....	0.25-0.50 mm
Second.....	0.20-0.35 mm
Oil control.....	0.25-0.58 mm
Camshaft	
Journal diameter, front.....	53.495-53.51 mm
Bearing clearance.....	0.030-0.095 mm
Center.....	53.45-53.47 mm
Bearing clearance.....	0.07-0.14 mm
Rear.....	53.48-53.50 mm
Bearing clearance.....	0.04-0.11 mm
Tappets	
Outside diameter.....	14.965-14.985 mm
Rocker gear	
Shaft diameter.....	21.979-22.00 mm
Bush internal diameter.....	22.020-22.041 mm
Assembly clearance.....	0.020-0.062 mm
Valves	
Intake valve:	
Opens.....	22° B.T.D.C.
Closes.....	46° A.B.D.C.
Exhaust valve:	
Opens.....	60° B.B.D.C.
Closes.....	24° A.T.D.C.

Description	Specifications
Face angle:	
Intake.....	56° - 56° 20'
Exhaust.....	45° 25' - 45° 35'
Head diameter:	
Intake.....	40.05-40.25 mm
Exhaust.....	33.8-34.0 mm
Head stand down:	
Intake.....	0.88-1.14 mm
Exhaust.....	0.99-1.25 mm
Stem diameter:	
Intake.....	7.940-7.960 mm
Exhaust.....	7.922-7.940 mm
Clearance in guide:	
Intake.....	0.040-0.075 mm
Exhaust.....	0.060-0.093 mm
Valve guide	
Inside diameter.....	8.0-8.015 mm
Fitted height.....	13.5-14 mm
Valve springs	
Free length.....	44.65 mm
Fitted length.....	38.6 mm
Load at fitted length.....	34 +/- 3% Kg
Load at top of lift.....	92.5 +/- 3% Kg
Number of coils.....	5.33 Valve timing
Lubrication	
System pressure	
at 4000 rev/min.....	3.5 to 5.0 bar (oil at 90-100°C)
Pressure relief valve opens.....	6.38 bar
Pressure relief valve spring - free length.....	57.5 mm
Oil pump:	
Outer rotor end float.....	0.02-0.08 mm
Inner rotor end float.....	0.02-0.08 mm
Outer rotor to body diam. clearance.....	0.130-0.230 mm
Rotor body to drive gear clearance (pump not fitted).....	0.30 - 0.56 mm

SPECIFICATIONS (Continued)

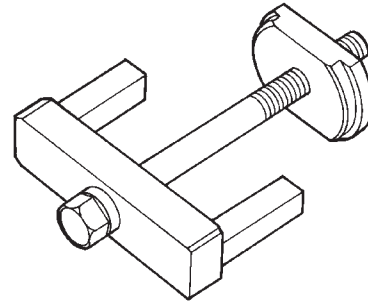
TORQUE SPECIFICATIONS

DESCRIPTION	TORQUE
Adaptor Plate to Block	
Nuts (6)	26.5 N·m (20 ft. lbs.)
Automatic Belt Tensioner to Block	
Bolts (2)	121 N·m
Automatic Belt Tensioner to Mounting Bracket	
Bolt (1)	75 N·m
Generator belt	
Tensioner	79 N·m
Generator bracket	
Mounting bolts (6 mm)	10 N·m
Mounting bolts (8 mm)	24.4 N·m
Generator	
Mounting bolt	47 N·m
Camshaft thrust plate	
Bolts	24 N·m
Connecting rod	
Mounting bolt	29.5 N·m +60°
Crankshaft bearing	
Carrier screw	42 N·m
Crankshaft pulley	
Locknut	160 N·m
Crossmember	
Bolts	42 N·m
Diesel delivery	
Union nut	18.5 N·m
EGR valve	
To intake manifold	26 N·m
EGR tube	
To EGR valve	26 N·m
Engine mount—Front	
Engine support bracket	61 N·m
Support Cushion	47 N·m
Support cushion bracket bolts	54 N·m
Support cushion bracket stud nuts	41 N·m
Support Cushion through bolt	65 N·m
Engine mount—Rear	
Transmission support bracket	46 N·m
Support Cushion nuts	75 N·m
Support Cushion through bolt	65 N·m
Exhaust down pipe	
To turbocharger	22 N·m
Exhaust heat shield	
Screws	11 N·m
Exhaust manifold collar	
Mounting nut	24.5 to 29.5 N·m
Exhaust manifold	
Mounting nut	32.5 N·m
Fan drive	
To fan hub	56 N·m
Flywheel	
Lock bolt	20 N·m +60°

DESCRIPTION	TORQUE
Front timing cover	
6 mm bolts	10 N·m
8 mm bolts	26 N·m
Fuel filter	
Nuts	28 N·m
Glow plug	
Torque	13.0 N·m
Idler pulley bracket	
Bolts	40 N·m
Idler pulley	
Bolt (left hand thread)	47 N·m
Injection pump fuel lines	
Nut	23 N·m
Injection pump gear	
Lock nut	86 N·m
Injection pump	
Mounting nut	27.5 N·m
Injector	
Torque	68.5 N·m
Intake manifold	
Mounting nut	32.5 N·m
Main bearing oil delivery	
Union	54 N·m
Water hose to cylinder head	
Nut	8 to 10 N·m
Oil cooler adaptor	
Bolt	60 N·m
Oil feed line	
For rocker arms	12 N·m
To block	27 N·m
To vacuum pump	15 N·m
Oil filter	
Torque	18 N·m
Oil filter adapter	
Torque	46.6 N·m
Oil filter base	
Torque	46.6 N·m
Oil pan	
Mounting bolts	13 N·m
Oil pickup tube	
Torque	25 N·m
Oil pump	
Mounting screw	27 N·m
Oil sump drain plug	
Torque	54 N·m
Power steering pressure hose	
Nut	28 N·m
Power steering pulley	
Nut	130 N·m
Rear crankshaft bearing carrier Allen Bolts	
Torque	11 N·m
Rocker cover	
Bolts	19 N·m

SPECIFICATIONS (Continued)

DESCRIPTION	TORQUE
Rocker mounting	
Lock Nut	35 N·m
Steering pump	
Bolts	28 N·m
Turbocharger	
Mounting nuts	32.5 N·m
Turbocharger	
Oil delivery fitting	27.5 N·m
Turbocharger oil drain	
Plug	10.8 N·m
Vacuum pump	
Torque	27 N·m
Water manifold	
Bolts	12 N·m
Water pump pulley	
Nut	27 N·m

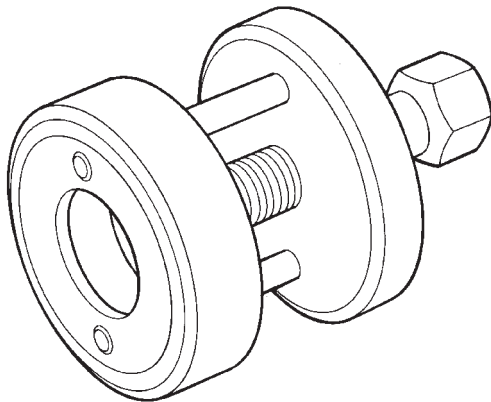


803fd6a2

Cylinder Liner Puller VM, 1001

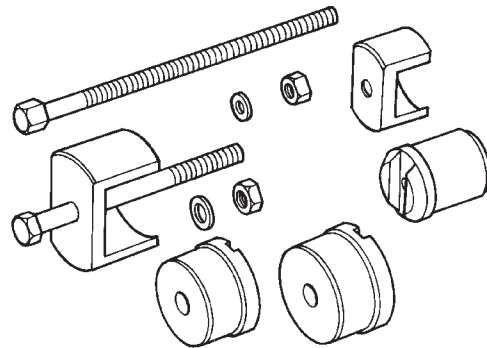
SPECIAL TOOLS

SPECIAL TOOLS



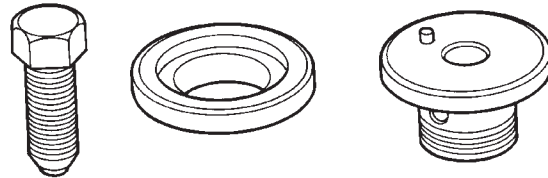
803fd6a1

Crankshaft Pulley and Gear Remover VM. 1000A



803fd6a3

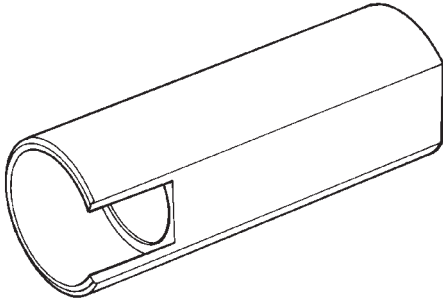
Crankshaft Bearing Remover/Replacer VM. 1002



803fd6a4

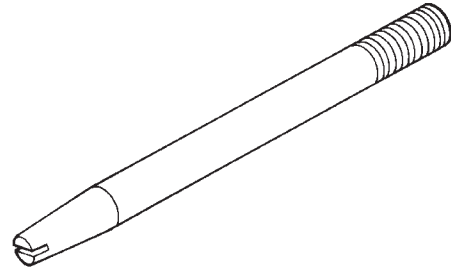
Injection Pump Puller and Gear retainer VM. 1003

SPECIAL TOOLS (Continued)



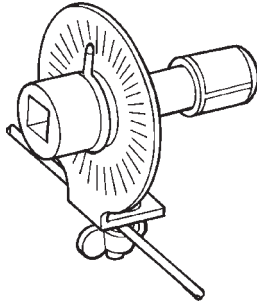
803fd6a5

Crankshaft Remover/Replacer Sleeve VM. 1004



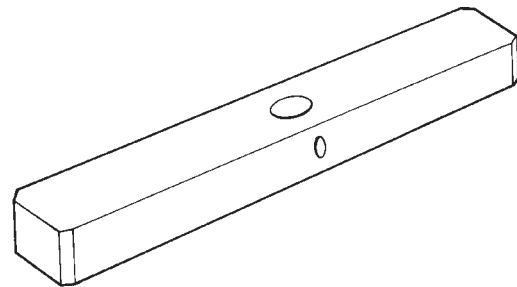
803fd6a9

Cylinder Head Guide Stud VM. 1009



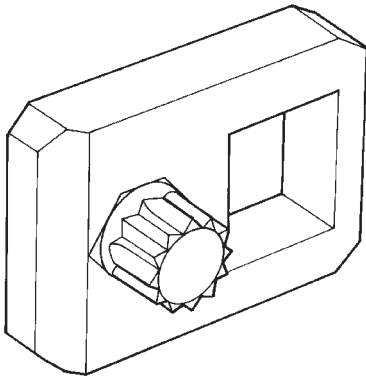
803fd6a6

Torque Angle Gauge VM. 1005



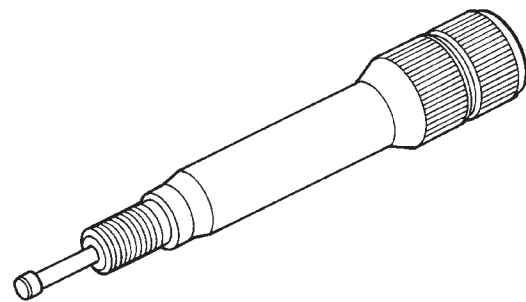
80a1aa3

Cylinder Liner Protrusion Tool VM. 1010



803fd6a7

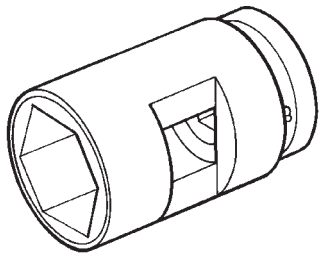
Cylinder Head Bolt Wrench VM. 1006A



80a1aa44

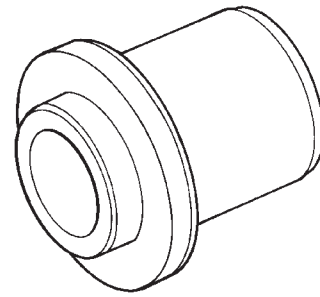
Bosch Pump Timing Adapter VM. 1011

SPECIAL TOOLS (Continued)



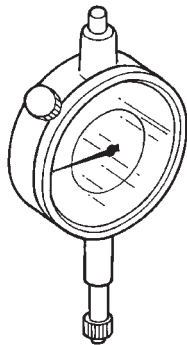
80a1aa45

Injector Remover/Replacer Socket VM. 1012



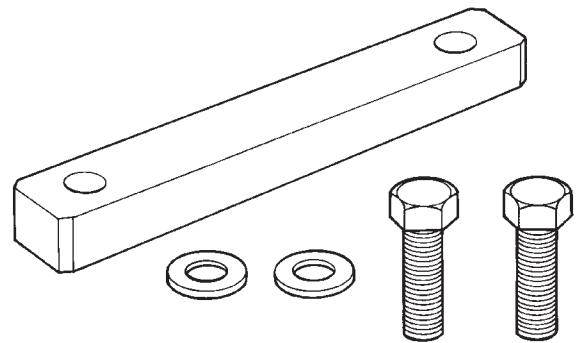
80a1aa48

Timing Cover Oil Seal Replacer VM. 1015



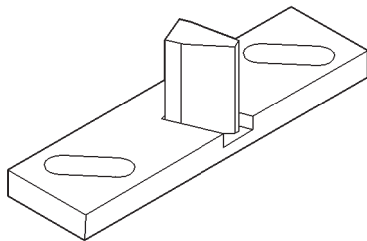
80a1aa46

Dial Indicator Gauge VM. 1013

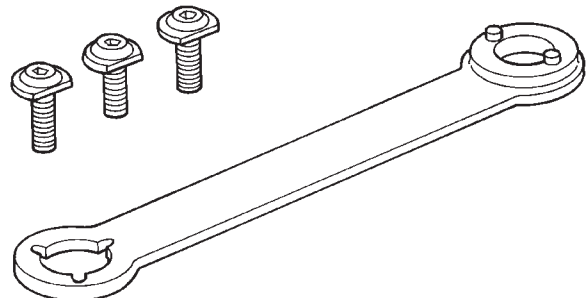


80a1aa49

Cylinder Retainer VM. 1016



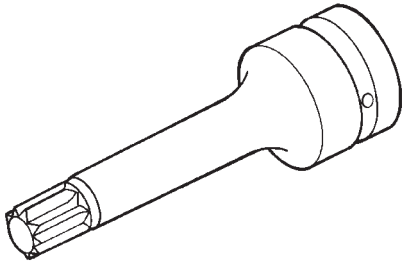
Flywheel Locking Tool VM. 1014



80a1aa4a

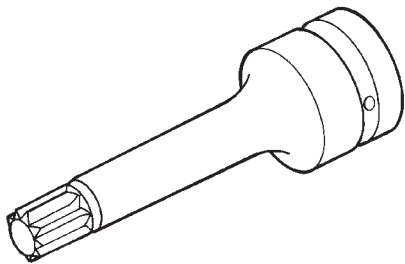
Crankshaft and Water Pump Pulley Holder VM. 1017

SPECIAL TOOLS (Continued)



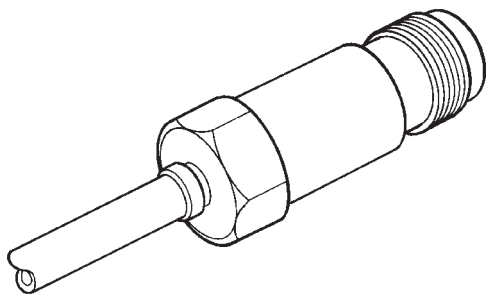
80a1aa4b

Cylinder Head Bolt Wrench M12 VM. 1018



80a1aa4c

Cylinder Head Bolt Wrench M14 VM. 1019



80a1aa4e

Cylinder Leakage Tester Adapter VM. 1021

EXHAUST SYSTEM AND INTAKE MANIFOLD

CONTENTS

	page		page
GENERAL INFORMATION			
CATALYTIC CONVERTER	2	INTAKE AND EXHAUST MANIFOLD—	
EXHAUST SYSTEM	1	4.0L ENGINE	5
HEAT SHIELDS	2	INTAKE MANIFOLD—5.2/5.9L ENGINE	6
DIAGNOSIS AND TESTING			
EXHAUST SYSTEM DIAGNOSIS	3	MUFFLER AND TAILPIPE	5
REMOVAL AND INSTALLATION			
CATALYTIC CONVERTER	4	CLEANING AND INSPECTION	
EXHAUST MANIFOLD—5.2/5.9L ENGINE	8	EXHAUST MANIFOLD—5.2/5.9L ENGINE	9
EXHAUST PIPE	3	INTAKE AND EXHAUST MANIFOLD—	
		4.0L ENGINE	9
		INTAKE MANIFOLD— 5.2/5.9L ENGINE	9
		SPECIFICATIONS	
		TORQUE	9

GENERAL INFORMATION

EXHAUST SYSTEM

The basic exhaust system consists of exhaust manifold(s), exhaust pipe with oxygen sensor, catalytic converter, heat shield(s), muffler and tailpipe (Fig. 1) (Fig. 2).

The exhaust system uses a single muffler with a single monolithic-type catalytic converter.

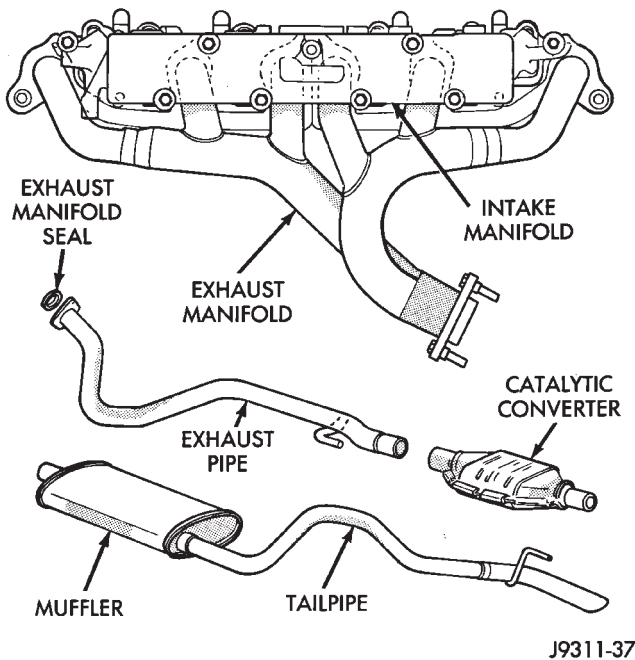


Fig. 1 Exhaust System—4.0L

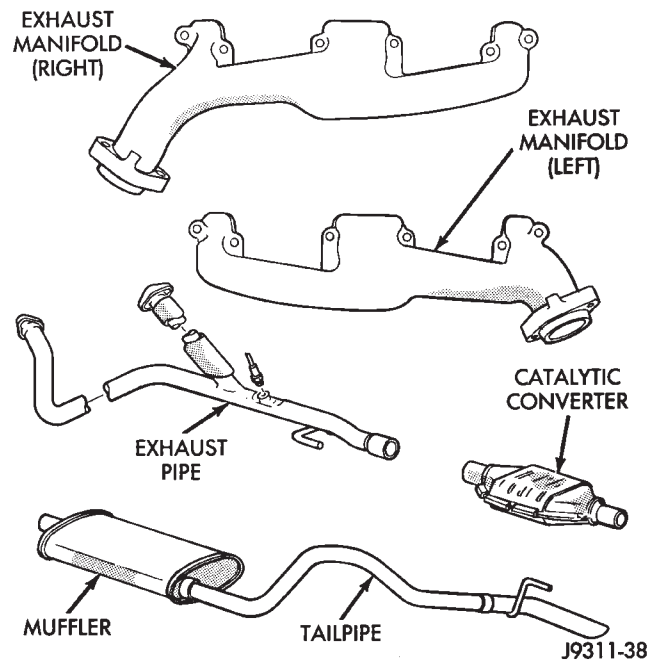


Fig. 2 Exhaust System—5.2L/5.9L

The 4.0L engines use a seal between the exhaust manifold and exhaust pipe to assure a tight seal and strain free connections.

The 5.2L/5.9L exhaust manifolds are equipped with ball flange outlets to assure a tight seal and strain free connections.

The exhaust system must be properly aligned to prevent stress, leakage and body contact. If the system contacts any body panel, it may amplify objectionable noises originating from the engine or body.

When inspecting an exhaust system, critically inspect for cracked or loose joints, stripped screw or

GENERAL INFORMATION (Continued)

bolt threads, corrosion damage and worn, cracked or broken hangers. Replace all components that are badly corroded or damaged. DO NOT attempt to repair.

When replacement is required, use original equipment parts (or their equivalent). This will assure proper alignment and provide acceptable exhaust noise levels.

CAUTION: Avoid application of rust prevention compounds or undercoating materials to exhaust system floor pan heat shields. Light over spray near the edges is permitted. Application of coating will result in excessive floor pan temperatures and objectionable fumes.

CATALYTIC CONVERTER

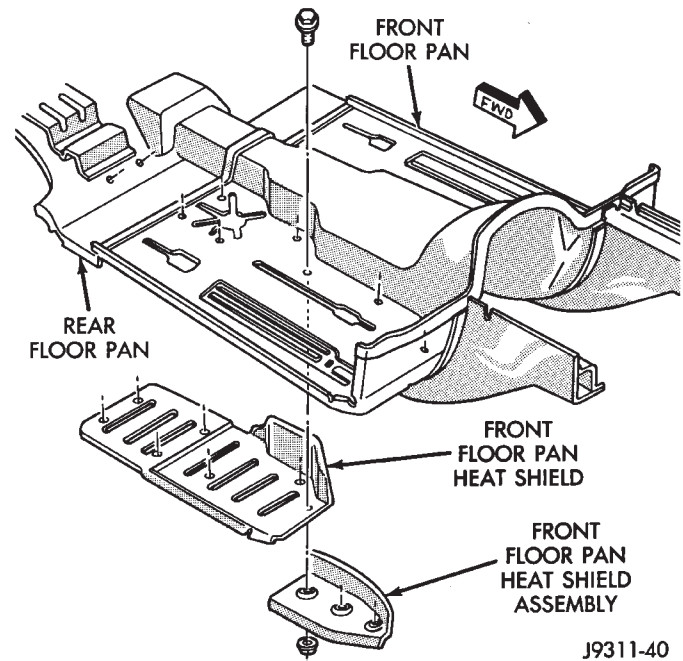
CAUTION: DO NOT remove spark plug wires from plugs or by any other means short out cylinders. Failure of the catalytic converter can occur due to a temperature increase caused by unburned fuel passing through the converter.

The stainless steel catalytic converter body is designed to last the life of the vehicle. Excessive heat can result in bulging or other distortion, but excessive heat will not be the fault of the converter. If unburned fuel enters the converter, overheating may occur. If a converter is heat-damaged, correct the cause of the damage at the same time the converter is replaced. Also, inspect all other components of the exhaust system for heat damage.

Unleaded gasoline must be used to avoid contaminating the catalyst core.

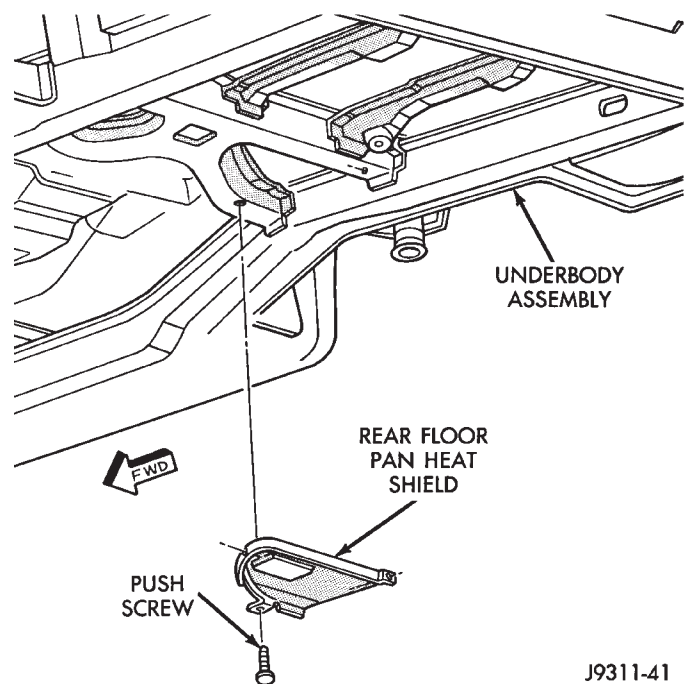
HEAT SHIELDS

Heat shields are needed to protect both the vehicle and the environment from the high temperatures developed by the catalytic converter (Fig. 3) (Fig. 4). The catalytic converter releases additional heat into the exhaust system. Under severe operating conditions, the temperature increases in the area of the converter. Such conditions can exist when the engine misfires or otherwise does not operate at peak efficiency.



J9311-40

Fig. 3 Front Floor Pan Heat Shield



J9311-41

Fig. 4 Rear Floor Pan Heat Shield

DIAGNOSIS AND TESTING

EXHAUST SYSTEM DIAGNOSIS

CONDITION	POSSIBLE CAUSE	CORRECTION
EXCESSIVE EXHAUST NOISE	1. Leaks at pipe joints. 2. Burned or blown out muffler. 3. Burned or rusted-out exhaust pipe. 4. Exhaust pipe leaking at manifold flange. 5. Exhaust manifold cracked or broken. 6. Leak between exhaust manifold and cylinder head. 7. Restriction in muffler or tailpipe. 8. Exhaust system contacting body or chassis.	1. Tighten clamps at leaking joints. 2. Replace muffler assembly. Check exhaust system. 3. Replace exhaust pipe. 4. Tighten connection attaching nuts. 5. Replace exhaust manifold. 6. Tighten exhaust manifold to cylinder head stud nuts or bolts. 7. Remove restriction, if possible. Replace muffler or tailpipe, as necessary. 8. Re-align exhaust system to clear surrounding components.
LEAKING EXHAUST GASES	1. Leaks at pipe joints. 2. Damaged or improperly installed gaskets.	1. Tighten/replace clamps at leaking joints. 2. Replace gaskets as necessary

REMOVAL AND INSTALLATION

EXHAUST PIPE

REMOVAL

WARNING: IF TORCHES ARE USED WHEN WORKING ON THE EXHAUST SYSTEM, DO NOT ALLOW THE FLAME NEAR THE FUEL LINES.

CAUTION: When servicing exhaust system components, disconnect the oxygen sensor connector(s). Allowing the exhaust system to hang by the oxygen sensor harness will damage the sensor and/or wiring.

- (1) Raise and support the vehicle.
- (2) Saturate the bolts and nuts with heat valve lubricant. Allow 5 minutes for penetration.
- (3) Remove the oxygen sensor from the exhaust pipe (Fig. 5) (Fig. 6).
- (4) Disconnect the exhaust pipe from the engine exhaust manifold. On 4.0L engines, discard the exhaust manifold seal (Fig. 5).
- (5) Remove the exhaust clamp from the exhaust pipe and catalytic converter connection (Fig. 5) (Fig. 6). Disconnect the exhaust pipe from the catalytic converter. If needed:
 - (a) Heat the exhaust pipe and catalytic converter connection with an torch until the metal becomes cherry red.

(b) While the metal is still cherry red, twist the exhaust pipe back and forth to separate it from the catalytic converter.

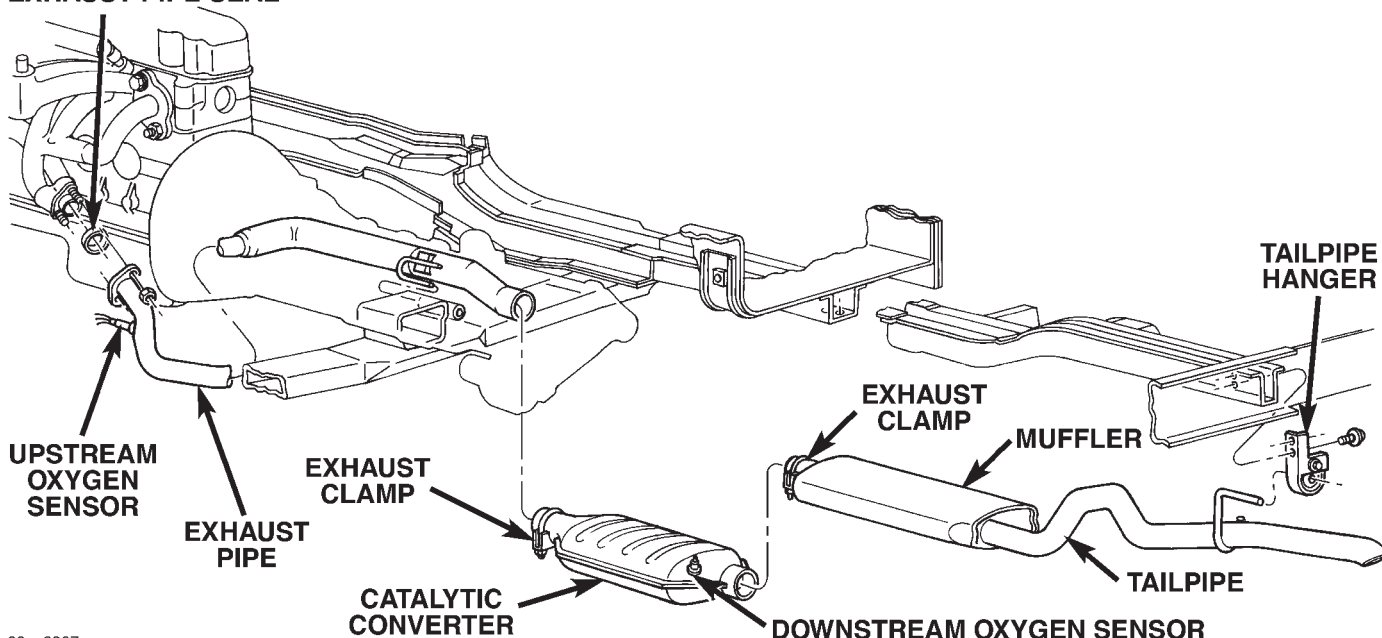
- (6) Disconnect the exhaust pipe hanger from the rear mount bracket insulator.
- (7) Remove the exhaust pipe.

INSTALLATION

- (1) Position the exhaust pipe onto the catalytic converter.
- (2) Connect the exhaust pipe hanger to the rear mount bracket insulator.
- (3) On 4.0L engines, install a new seal between the exhaust pipe and the engine exhaust manifold (Fig. 5). Connect the exhaust pipe to the engine exhaust manifold. Tighten the nuts to 31 N·m (23 ft. lbs.) torque.
- (4) Position the exhaust clamp over the exhaust pipe/catalytic converter connection (Fig. 5) (Fig. 6). Tighten the nuts to 48 N·m (35 ft. lbs.) torque.
- (5) Coat the oxygen sensor with anti-seize compound. Install the sensor and tighten the nut to 30 N·m (22 ft. lbs.) torque.
- (6) Lower the vehicle.
- (7) Start the engine and inspect for exhaust leaks and exhaust system contact with the body panels. Adjust the alignment, if needed.
- (8) After initial start-up, check the exhaust manifold to pipe nuts for proper torque.

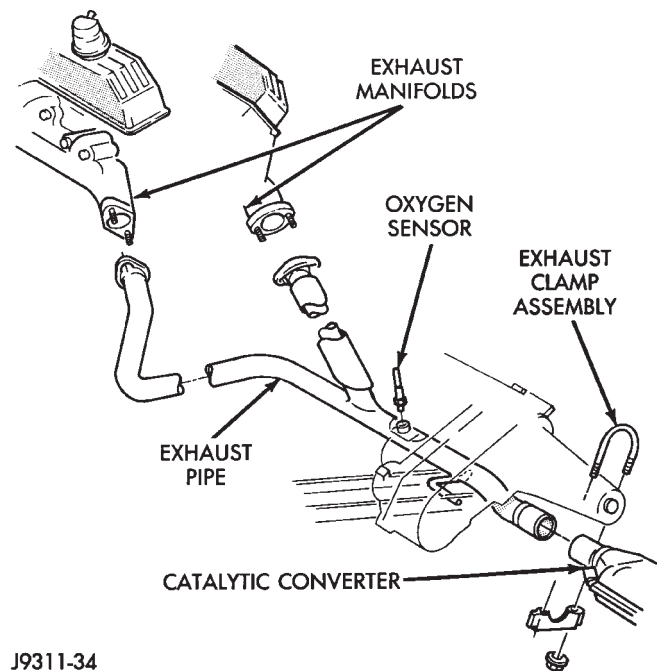
REMOVAL AND INSTALLATION (Continued)

EXHAUST PIPE SEAL



80ae8367

Fig. 5 Exhaust System—4.0L Engine



J9311-34

Fig. 6 Exhaust Pipe—5.2L/5.9L Engines

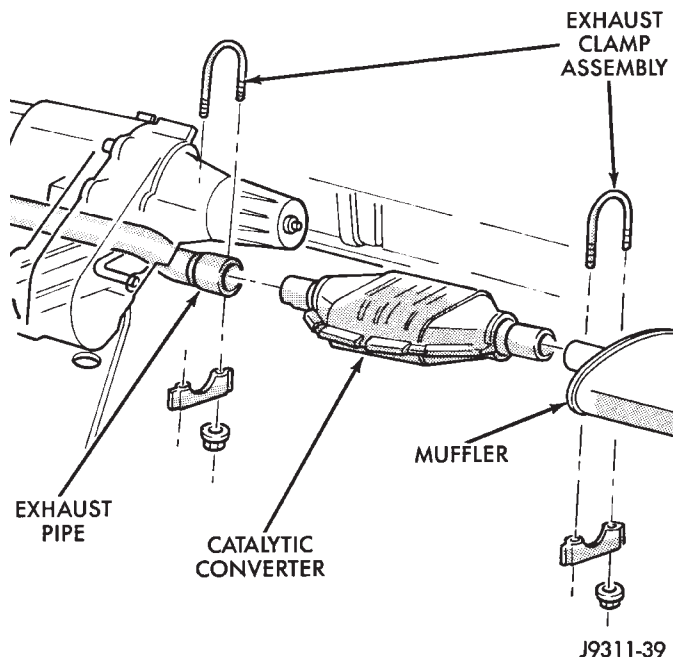
CATALYTIC CONVERTER

REMOVAL

WARNING: IF TORCHES ARE USED WHEN WORKING ON THE EXHAUST SYSTEM, DO NOT ALLOW THE FLAME NEAR THE FUEL LINES.

- (1) Raise and support the vehicle.
- (2) Saturate the bolts and nuts with heat valve lubricant. Allow 5 minutes for penetration.

- (3) Remove exhaust clamp from the catalytic converter and exhaust pipe connection (Fig. 7).
- (4) Remove exhaust clamp from the catalytic converter and muffler connection (Fig. 7).
- (5) Disconnect oxygen sensor wiring.



J9311-39

Fig. 7 Exhaust Pipe-to-Catalytic Converter-to-Muffler Connection

- (6) Heat the exhaust pipe, catalytic converter and muffler connections with an torch until the metal becomes cherry red.

REMOVAL AND INSTALLATION (Continued)

(7) While the metal is still cherry red, twist the catalytic converter back and forth to separate it from the exhaust pipe and the muffler.

INSTALLATION

(1) Position the exhaust clamp over the exhaust pipe/catalytic converter connection (Fig. 7). Tighten the nuts to 61 N·m (45 ft. lbs.) torque.

(2) Install the muffler onto the catalytic converter until the alignment tab is inserted into the alignment slot.

(3) Install the exhaust clamp at the muffler and catalytic converter connection (Fig. 7). Tighten the clamp nuts to 61 N·m (45 ft. lbs.) torque.

(4) Connect oxygen sensor wiring.

(5) Lower the vehicle.

(6) Start the engine and inspect for exhaust leaks and exhaust system contact with the body panels. Adjust the alignment, if needed.

MUFFLER AND TAILPIPE**REMOVAL**

All original equipment exhaust systems are manufactured with the tailpipe welded to the muffler. Service replacement mufflers and tailpipes are either clamped together or welded together.

WARNING: IF TORCHES ARE USED WHEN WORKING ON THE EXHAUST SYSTEM, DO NOT ALLOW THE FLAME NEAR THE FUEL LINES.

(1) Raise and support the vehicle.

(2) Saturate the bolts and nuts with heat valve lubricant. Allow 5 minutes for penetration.

(3) Remove the exhaust clamp from the catalytic converter and muffler connection (Fig. 7).

(4) Heat the catalytic converter-to-muffler connection with an torch until the metal becomes cherry red.

(5) While the metal is still cherry red, remove the tailpipe/muffler assembly from the catalytic converter.

(6) Remove the tailpipe from the tailpipe hanger (Fig. 8).

(7) Remove the tailpipe/muffler assembly.

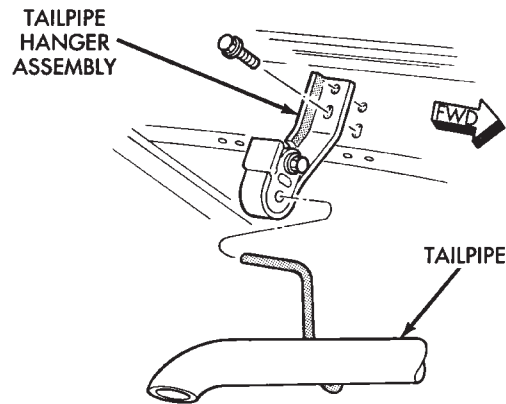
INSTALLATION

(1) If the tailpipe hanger assembly was removed, install the hanger to the frame. Tighten the bolts to 22 N·m (192 in. lbs.) torque.

(2) Position the tailpipe and muffler onto the tailpipe hanger (Fig. 8).

(3) Install the muffler onto the catalytic converter. Make sure that the tailpipe has sufficient clearance from the floor pan. Install exhaust clamp and tighten the nuts to 61 N·m (45 ft. lbs.) torque.

(4) Lower the vehicle.



J9311-33

Fig. 8 Tailpipe Hanger

(5) Start the engine and inspect for exhaust leaks and exhaust system contact with the body panels. Adjust the alignment, if needed.

INTAKE AND EXHAUST MANIFOLD—4.0L ENGINE**REMOVAL**

NOTE: THE ENGINE INTAKE AND EXHAUST MANIFOLD MUST BE REMOVED AND INSTALLED TOGETHER. THE MANIFOLDS USE A COMMON GASKET AT THE CYLINDER HEAD.

(1) Disconnect the battery negative cable.

(2) Remove air cleaner inlet hose from throttle body assembly.

(3) Remove the air cleaner assembly.

(4) Remove the throttle cable, vehicle speed control cable (if equipped) and the transmission line pressure cable.

(5) Disconnect the following electrical connections and secure their harness out of the way:

- Throttle Position Sensor
- Idle Air Control Motor
- Coolant Temperature Sensor (at thermostat housing)

- Intake Air Temperature Sensor

- Oxygen Sensor

- Crank Position Sensor

- Six (6) Fuel Injector Connectors

(6) Disconnect the Map Sensor, HVAC, and Brake Booster vacuum supply hoses at the intake manifold.

(7) Perform the fuel pressure release procedure. (Refer to Group 14, Fuel Systems for correct procedure)

(8) Disconnect and remove the fuel system supply line from the fuel rail assembly. (Refer to Group 14, Quick Connect Fittings for correct procedures)

(9) Loosen the accessory drive belt (refer to Group 7, Cooling System). Loosen the tensioner.

(10) Remove the power steering pump and bracket from the intake manifold and set aside.

REMOVAL AND INSTALLATION (Continued)

- (11) Raise the vehicle.
- (12) Disconnect the exhaust pipe from the engine exhaust manifold. Discard the seal.
- (13) Lower the vehicle.
- (14) Remove the intake manifold and engine exhaust manifold.

INSTALLATION

If the manifold is being replaced, ensure all the fitting, etc. are transferred to the replacement manifold.

- (1) Install a new engine exhaust/intake manifold gasket over the alignment dowels on the cylinder head.
- (2) Position the engine exhaust manifold to the cylinder head. Install fastener Number 3 and finger tighten at this time (Fig. 9).
- (3) Install intake manifold on the cylinder head dowels.
- (4) Install washer and fastener Numbers 1, 2, 4, 5, 8, 9, 10 and 11 (Fig. 9).
- (5) Install washer and fastener Numbers 6 and 7 (Fig. 9).
- (6) Tighten the fasteners in sequence and to the specified torque (Fig. 9).
 - Fastener Numbers 1 through 5—Tighten to 33 N·m (24 ft. lbs.) torque.
 - Fastener Numbers 6 and 7—Tighten to 31 N·m (23 ft. lbs.) torque.
 - Fastener Numbers 8 through 11—Tighten to 33 N·m (24 ft. lbs.) torque.

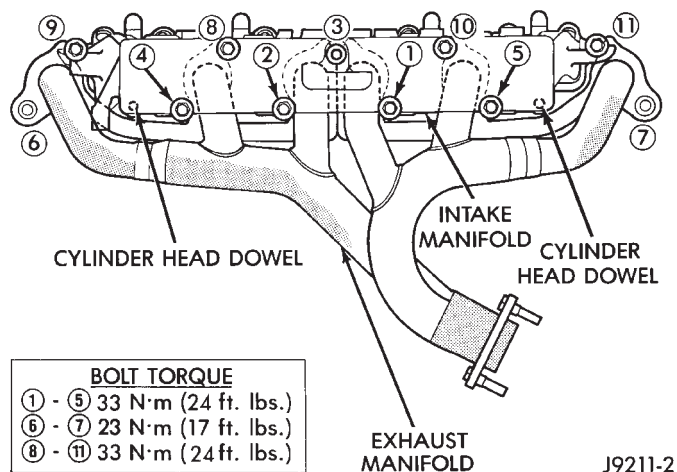


Fig. 9 Engine Exhaust/Intake Manifold

- (7) Install the power steering pump and bracket to the intake manifold. Tighten the belt to specification. (Refer to Group 7, Cooling System for the correct procedures)
- (8) Install the fuel system supply line to the fuel rail assembly. **Before connecting the fuel supply line to the fuel rail inspect the O-rings and**

replace if necessary. Refer to Group 14, Fuel System for the correct procedure.

- (9) Connect all electrical connections on the intake manifold.
- (10) Connect the vacuum hoses previously removed.
- (11) Install throttle cable, vehicle speed control cable (if equipped).
- (12) Install the transmission line pressure cable (if equipped). Refer to Group 21, Transmission for the adjustment procedures.
- (13) Install air cleaner assembly.
- (14) Connect air inlet hose to the throttle body assembly.
- (15) Raise the vehicle.
- (16) Using a new exhaust manifold seal, connect the exhaust pipe to the engine exhaust manifold. Tighten the bolts to 31 N·m (23 ft. lbs.)
- (17) Lower the vehicle.
- (18) Connect the battery negative cable.
- (19) Start the engine and check for leaks.

INTAKE MANIFOLD—5.2/5.9L ENGINE**REMOVAL**

The aluminum intake manifold is a single plane design with equal length runners. The manifold is sealed by flange side gaskets with front and rear cross-over gaskets. The intake manifold has internal EGR.

- (1) Disconnect the battery negative cable.
- (2) Drain the cooling system (refer to Group 7, Cooling System for the proper procedures).
- (3) Remove the generator (refer to Group 8B Battery/Starting/Charging Systems).
- (4) Remove the air cleaner.
- (5) Remove the fuel supply line and fuel rail (refer to Group 14, Fuel System).
- (6) Disconnect the accelerator linkage and, if so equipped, the speed control and transmission kick-down cables.
- (7) Remove the distributor cap and wires.
- (8) Disconnect the coil wires.
- (9) Disconnect the heat indicator sending unit wire.
- (10) Disconnect the heater hoses and bypass hose.
- (11) Remove the closed crankcase ventilation and evaporation control systems.
- (12) Remove the A/C compressor bolts and set the compressor on the fan shroud.
- (13) Remove the support bracket from the intake manifold and the mounting bracket.
- (14) Remove intake manifold bolts.
- (15) Lift the intake manifold and throttle body out of the engine compartment as an assembly.
- (16) Remove and discard the flange side gaskets and the front and rear cross-over gaskets.

REMOVAL AND INSTALLATION (Continued)

(17) Remove the throttle body bolts and lift the throttle body off the intake manifold. Discard the throttle body gasket.

(18) Remove the plenum pan as follows:

- (a) Turn the intake manifold upside down. Support the manifold.
- (b) Remove the bolts and lift the pan off the manifold. Discard the gasket.

INSTALLATION

(1) Install the plenum pan, if removed, as follows:

- (a) Turn the intake manifold upside down. Support the manifold.
- (b) Place a new plenum pan gasket onto the seal rail of the intake manifold. Position the pan over the gasket. Align all the gasket and pan holes with the intake manifold.
- (c) Hand start all bolts.
- (d) Tighten the bolts, in sequence (Fig. 10), as follows:

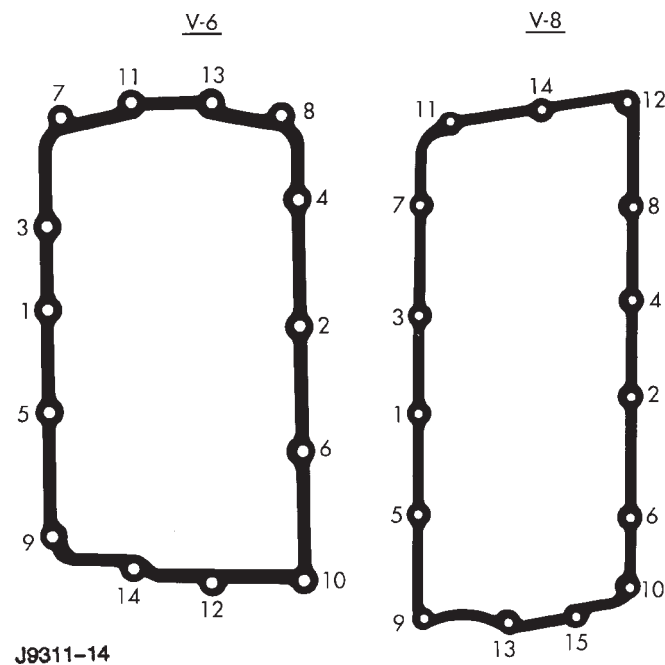


Fig. 10 Plenum Pan Bolt Tightening Sequence

- Step 1—Tighten bolts to 2.7 N·m (24 in. lbs.) torque.
 - Step 2—Tighten bolts to 5.4 N·m (48 in. lbs.) torque.
 - Step 3—Tighten bolts to 9.5 N·m (84 in. lbs.) torque.
 - Step 4—Check that all bolts are tighten to 9.5 N·m (84 in. lbs.) torque.
- (2) Using a new gasket, install the throttle body onto the intake manifold. Tighten the bolts to 23 N·m (200 in. lbs.) torque.
- (3) Place the 4 plastic locator dowels into the holes in the block (Fig. 11).

(4) Apply Mopar® Silicone Rubber Adhesive Sealant, or equivalent, to the four corner joints. An excessive amount of sealant is not required to ensure a leak proof seal. However, an excessive amount of sealant may reduce the effectiveness of the flange gasket. The sealant should be slightly higher than the cross-over gaskets, approximately 5 mm (0.2 in).

(5) Install the front and rear cross-over gaskets onto the dowels (Fig. 11).

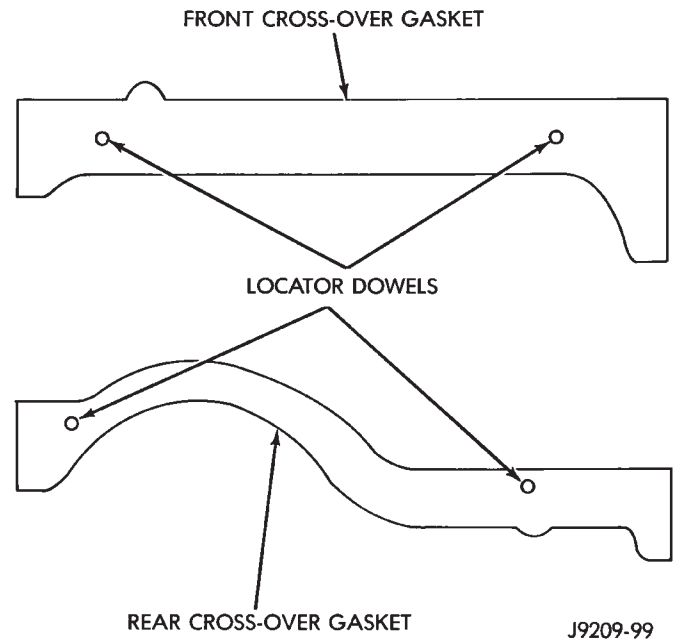


Fig. 11 Cross-Over Gaskets and Locator Dowels

(6) Install the flange gaskets. Ensure that the vertical port alignment tab is resting on the deck face of the block. Also the horizontal alignment tabs must be in position with the mating cylinder head gasket tabs (Fig. 12). The words MANIFOLD SIDE should be visible on the center of each flange gasket.

(7) Carefully lower intake manifold into position on the cylinder block and cylinder heads. Use the alignment dowels in the cross-over gaskets to position the intake manifold. After intake manifold is in place, inspect to make sure seals are in place.

(8) The following torque sequence duplicates the expected results of the automated assembly system (Fig. 13).

- Step 1—Tighten bolts 1 through 4, in sequence, to 8 N·m (72 in. lbs.) torque. Tighten in alternating steps 1.4 N·m (12 in. lbs.) torque at a time.
- Step 2—Tighten bolts 5 through 12, in sequence, to 8 N·m (72 in. lbs.) torque.
- Step 3—Check that all bolts are tighten to 8 N·m (72 in. lbs.) torque.
- Step 4—Tighten all bolts, in sequence, to 16 N·m (12 ft. lbs.) torque.
- Step 5—Check that all bolts are tighten to 16 N·m (12 ft. lbs.) torque.

REMOVAL AND INSTALLATION (Continued)

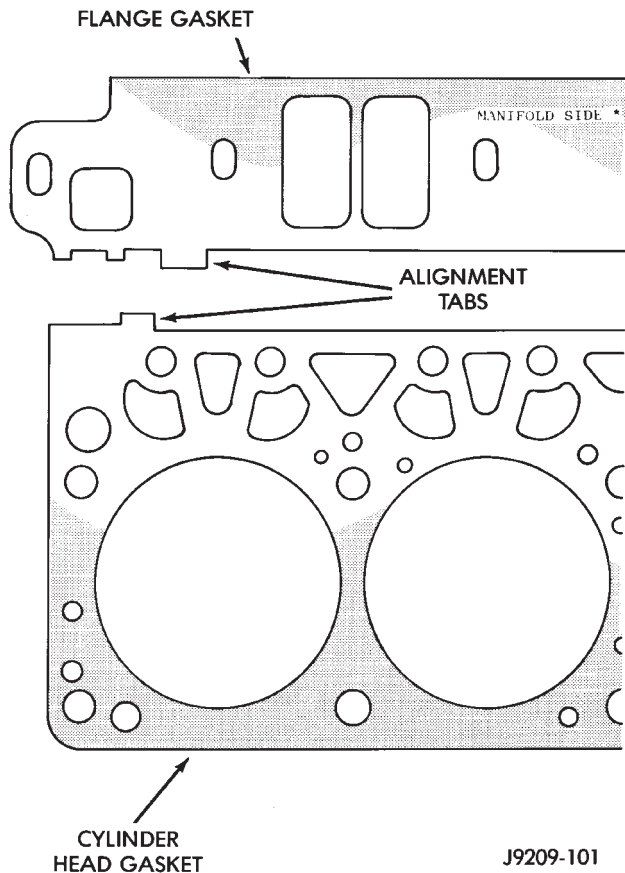


Fig. 12 Intake Manifold Flange Gasket Alignment

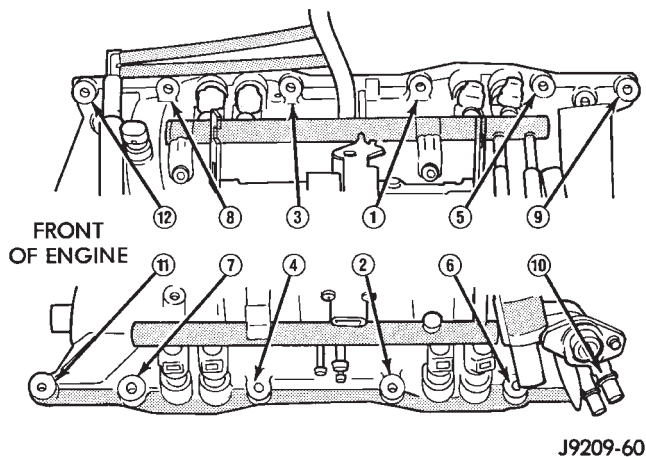


Fig. 13 Intake Manifold Bolt Tightening Sequence

- (9) Install closed crankcase ventilation and evaporation control systems.
- (10) Install the coil wires.
- (11) Connect the heat indicator sending unit wire.
- (12) Connect the heater hoses and bypass hose.
- (13) Install distributor cap and wires.
- (14) Hook up the return spring.
- (15) Connect the accelerator linkage and, if so equipped, the speed control and transmission kick-down cables.

(16) Install the fuel lines and fuel rail (refer to Group 14, Fuel System).

(17) Install the support bracket to the intake manifold and the mounting bracket.

(18) Install the generator and drive belt. Tighten generator mounting bolt to 41 N-m (30 ft. lbs.) torque. Tighten the adjusting strap bolt to 23 N-m (200 in. lbs.) torque. Refer to Group 7, Cooling System for the proper adjusting of belt tension.

(19) Install the A/C compressor on the mounting bracket (refer to Group 24, Heating and Air Conditioning).

(20) Install the air cleaner.

(21) Fill cooling system (refer to Group 7, Cooling System for the proper procedure).

(22) Connect the battery negative cable.

EXHAUST MANIFOLD—5.2/5.9L ENGINE

REMOVAL

Exhaust manifolds are LOG type with balanced flow.

- (1) Disconnect the negative cable from the battery.
- (2) Remove the exhaust manifold heat shields (Fig. 14).

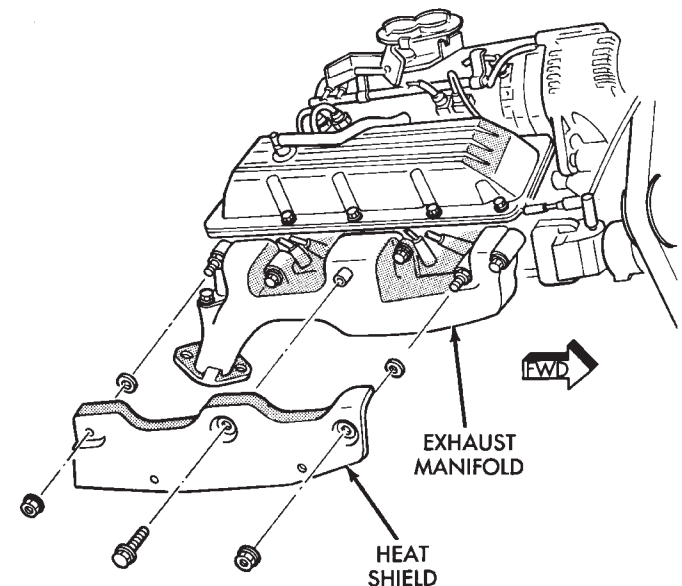


Fig. 14 Exhaust Manifold Heat Shields (Left Shield Shown)

(3) Remove the EGR tube (refer to Group 25, Emission Control Systems).

(4) Raise the vehicle.

(5) Remove the bolts and nuts attaching the exhaust pipe to the exhaust manifold.

(6) Lower the vehicle.

(7) Remove bolts, nuts and washers attaching manifold to cylinder head.

(8) Remove manifold from the cylinder head.

REMOVAL AND INSTALLATION (Continued)

INSTALLATION

CAUTION: If the studs came out with the nuts when removing the exhaust manifold, install new studs.

(1) Position the exhaust manifolds on the two studs located on the cylinder head. Install conical washers and nuts on these studs (Fig. 15).

(2) Install new bolt and washer assemblies in the remaining holes (Fig. 15). Start at the center arm and work outward. Tighten the bolts and nuts to 27 N·m (20 ft. lbs.) torque.

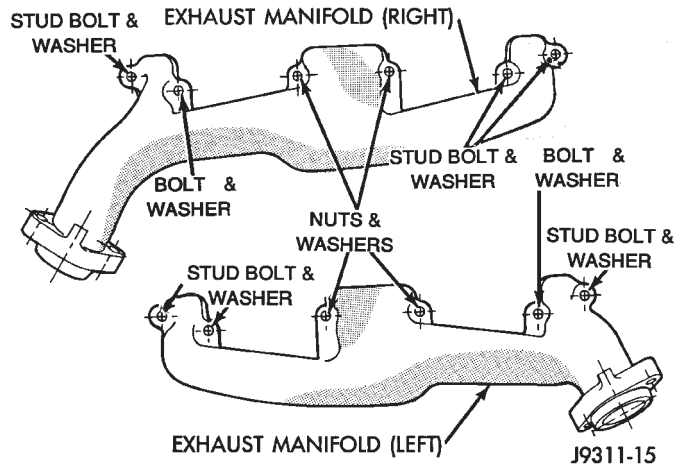


Fig. 15 Exhaust Manifold

- (3) Raise the vehicle.
- (4) Assemble the exhaust pipe to the exhaust manifold and secure with bolts, nuts and washers. Tighten these nuts to 31 N·m (23 ft. lbs.) torque.
- (5) Lower the vehicle.
- (6) Install the EGR tube (refer to Group 25, Emission Control Systems).

CAUTION: The exhaust manifold heat shields **MUST** be installed to protect the underhood components.

- (7) Install the exhaust manifold heat shields. Tighten the nuts to 27 N·m (20 ft. lbs.) torque.
- (8) Connect the negative cable to the battery.

CLEANING AND INSPECTION

INTAKE AND EXHAUST MANIFOLD—4.0L ENGINE

Clean the mating surfaces of the cylinder head and the manifold if the original manifold is to be installed.

INTAKE MANIFOLD— 5.2/5.9L ENGINE

CLEANING

Clean manifold in solvent and blow dry with compressed air.

Clean cylinder block front and rear gasket surfaces using a suitable solvent.

The plenum pan rail must be clean and dry (free of all foreign material).

INSPECTION

- Inspect manifold for cracks.
- Inspect mating surfaces of manifold for flatness with a straightedge.

EXHAUST MANIFOLD—5.2/5.9L ENGINE

CLEANING

Clean mating surfaces on cylinder head and manifold, wash with solvent and blow dry with compressed air. Inspect manifold for cracks.

INSPECTION

Inspect mating surfaces of manifold for flatness with a straight edge. Seal surfaces must be flat within 0.1 mm (0.004 inch) overall.

SPECIFICATIONS

TORQUE

DESCRIPTION	TORQUE
Catalytic Converter to Exhaust Pipe	
Exhaust Clamp48 N·m (35 ft. lbs.)
Exhaust Pipe to Manifold	
Nuts31 N·m (23 ft. lbs.)
Exhaust Manifold Heat Shield—(5.2L/5.9L)	
Nuts27 N·m (20 ft. lbs.)
Exhaust Manifold—(5.2L/5.9L)	
Nuts/Bolts27 N·m (20 ft. lbs.)
Floor Pan Heat Shield	
Bolts/Nuts.5 N·m (45 in. lbs.)
Generator Mounting	
Bolts41 N·m (30 ft. lbs.)
Intake/Exhaust Manifold—(4.0L)	
Intake/Exhaust Manifold	
Nuts/Bolts #1,2,4,5,8–11.33 N·m (24 ft. lbs.)
Exhaust Manifold Bolt #3.33 N·m (24 ft. lbs.)
Exhaust Manifold Nuts #6&731 N·m (23 ft. lbs.)
Intake Manifold—(5.2L/5.9L)	
Bolts	Refer to Procedure in This Section
Muffler to Catalytic Converter	
Exhaust Clamp48 N·m (35 ft. lbs.)
Oxygen Sensor	
Sensor30 N·m (22 ft. lbs.)
Plenum Pan—(5.2L/5.9L)	
Bolts	Refer to Procedure in This Section
Rear Tailpipe Hanger	
Bolts22 N·m (192 in. lbs.)

EXHAUST SYSTEM AND INTAKE MANIFOLD

CONTENTS

	page		page
GENERAL INFORMATION		EXHAUST PIPE	2
EXHAUST HEAT SHIELDS	1	INTAKE MANIFOLD	3
EXHAUST SYSTEM	1	MUFFLER AND EXHAUST TAILPIPE	2
REMOVAL AND INSTALLATION		SPECIFICATIONS	
ENGINE EXHAUST MANIFOLD AND		TORQUE SPECIFICATIONS	3
TURBOCHARGER	3		

GENERAL INFORMATION

EXHAUST SYSTEM

The basic exhaust system consists of an engine exhaust manifold, exhaust pipe, exhaust heat shield(s), muffler and exhaust tailpipe

The exhaust system uses a single muffler.

The exhaust system must be properly aligned to prevent stress, leakage and body contact. If the system contacts any body panel, it may amplify objectionable noises originating from the engine or body.

When inspecting an exhaust system, critically inspect for cracked or loose joints, stripped screw or bolt threads, corrosion damage and worn, cracked or broken hangers. Replace all components that are badly corroded or damaged. DO NOT attempt to repair.

When replacement is required, use original equipment parts (or equivalent). This will assure proper alignment and provide acceptable exhaust noise levels.

CAUTION: Avoid application of rust prevention compounds or undercoating materials to exhaust system floor pan exhaust heat shields. Light overspray near the edges is permitted. Application of coating will result in excessive floor pan temperatures and objectionable fumes.

EXHAUST HEAT SHIELDS

Exhaust heat shields are needed to protect both the vehicle and the environment from the high temperatures (Fig. 1).

DO NOT allow the engine to operate at fast idle for extended periods (over 5 minutes). This condition may result in excessive temperatures in the exhaust system and on the floor pan.

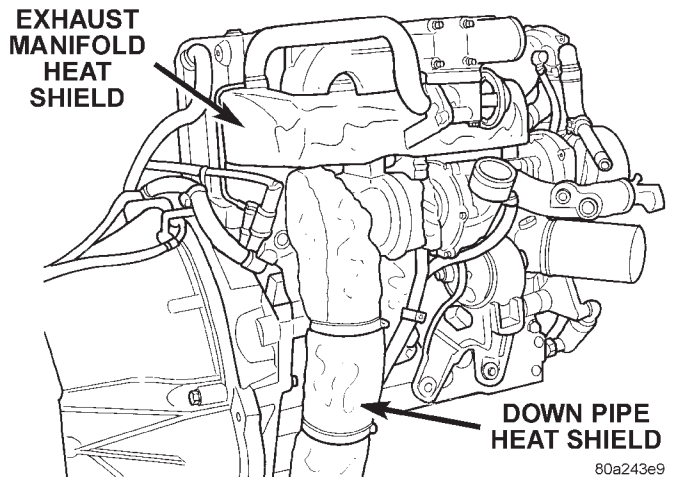


Fig. 1 Heat Shields

80a243e9

REMOVAL AND INSTALLATION

EXHAUST PIPE

WARNING: IF TORCHES ARE USED WHEN WORKING ON THE EXHAUST SYSTEM, DO NOT ALLOW THE FLAME NEAR THE FUEL LINES.

REMOVAL

- (1) Raise and support the vehicle.
- (2) Saturate the bolts and nuts at turbo down pipe to exhaust pipe with heat valve lubricant. Allow 5 minutes for penetration.
- (3) Disconnect bolts from exhaust pipe to turbo down pipe (Fig. 2).

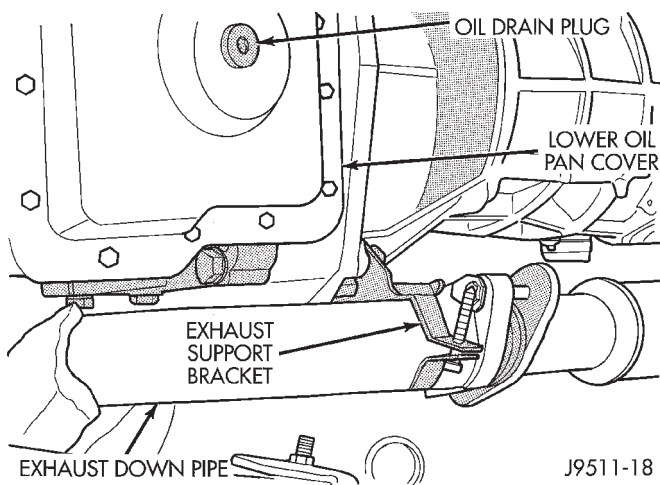


Fig. 2 Exhaust Down Pipe to Front Exhaust Pipe

- (4) Remove the clamp nuts at muffler (Fig. 3). To remove the exhaust pipe from the muffler, apply heat until the metal becomes cherry red. Disconnect the exhaust pipe from the muffler. Remove the exhaust pipe.

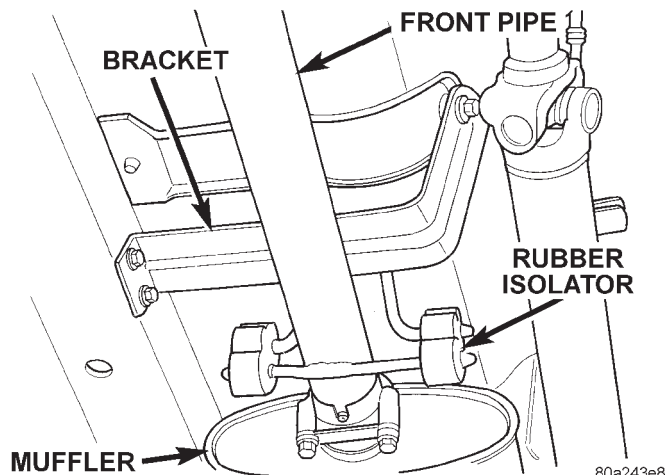


Fig. 3 Front Pipe to Muffler

INSTALLATION

- (1) Assemble exhaust pipe to muffler, loosely to permit proper alignment of all parts.
- (2) Connect the exhaust pipe to the turbo down pipe manifold. Tighten the bolts to 22.5 N·m torque.
- (3) Use a new clamp and tighten the nuts to 43 N·m torque.
- (4) Lower the vehicle.
- (5) Start the engine and inspect for exhaust leaks and exhaust system contact with the body panels. Adjust the alignment, if needed.

MUFFLER AND EXHAUST TAILPIPE

All original equipment exhaust systems are manufactured with the exhaust tailpipe welded to the muffler. Service replacement mufflers and exhaust tailpipes are either clamped together or welded together.

WARNING: IF TORCHES ARE USED WHEN WORKING ON THE EXHAUST SYSTEM, DO NOT ALLOW THE FLAME NEAR THE FUEL LINES.

REMOVAL

- (1) Raise and support the vehicle.
- (2) Remove the front muffler clamp from the exhaust pipe and muffler connection.
- (3) Remove the rear exhaust tailpipe hanger clamp and remove the exhaust tailpipe from the front exhaust tailpipe hanger.
- (4) Remove the exhaust tailpipe assembly from the muffler.

INSTALLATION

- (1) Install the muffler onto the exhaust pipe. Install the clamp and tighten the nuts finger tight.
- (2) Install the exhaust tailpipe into the rear of the muffler.
- (3) Install the exhaust tailpipe/muffler assembly on the rear exhaust tailpipe hanger. Make sure that the exhaust tailpipe has sufficient clearance from the floor pan.
- (4) Install the remaining clamps and the front exhaust tailpipe hanger.
- (5) Tighten the nuts on the muffler-to-exhaust pipe clamp to 43 N·m torque.
- (6) Tighten the nuts on the muffler-to-exhaust pipe clamp to 43 N·m torque.
- (7) Lower the vehicle.
- (8) Start the engine and inspect for exhaust leaks and exhaust system contact with the body panels. Adjust the alignment, if needed.

REMOVAL AND INSTALLATION (Continued)

ENGINE EXHAUST MANIFOLD AND TURBOCHARGER

REMOVAL

- (1) Disconnect the battery negative cable.
- (2) Remove air cleaner hoses from turbocharger.
- (3) Remove air cleaner assembly.
- (4) Remove charge air cooler hoses from turbocharger and intake manifold.
- (5) Remove all components attached to the intake manifold.
- (6) Remove the EGR tube and EGR valve.
- (7) Remove exhaust manifold heat shield.
- (8) Remove turbocharger oil feed line.
- (9) Remove exhaust down pipe from turbo.
- (10) Raise the vehicle.
- (11) Remove oil drain tube from turbocharger.
- (12) Lower the vehicle.
- (13) Remove turbocharger and exhaust manifold as an assembly.

CLEANING

Clean the exhaust manifold and cylinder head mating surfaces.

INSTALLATION

- (1) Install turbocharger to exhaust manifold tighten nuts to 27 N·m.
- (2) Install assembly to engine, tighten nuts to 30 N·m.
- (3) Install oil feed line to turbocharger, tighten nut to 26 N·m.
- (4) Install exhaust down pipe to turbocharger, tighten bolts to 27 N·m.
- (5) Install exhaust heat shield, tighten bolts to 11 N·m.
- (6) Loose install EGR tube and EGR valve to intake manifold.
- (7) Install EGR valve, tighten bolts to 26 N·m.
- (8) Tighten EGR tube nut to 26 N·m.
- (9) Tighten EGR tube flange bolts to 26 N·m.
- (10) Connect all components to intake manifold.
- (11) Connect charge air cooler hoses to turbocharger and intake manifold.
- (12) Install air cleaner assembly.
- (13) Connect air cleaner hose to turbocharger.
- (14) Raise the vehicle.
- (15) Install turbocharger drain line.
- (16) Lower the vehicle.
- (17) Connect the battery negative cable.
- (18) Start the engine and check for leaks.

INTAKE MANIFOLD

REMOVAL

- (1) Remove exhaust manifold and turbocharger assembly.

- (2) Remove water manifold.
- (3) Remove intake manifold.

CLEANING

Clean the intake manifold and cylinder head mating surfaces. **DO NOT allow foreign material to enter either the intake manifold or the ports in the cylinder head.**

INSTALLATION

- (1) Install the new intake manifold gasket.
- (2) Position the intake manifold in place and finger tighten the mounting nuts.
- (3) Tighten the fasteners in sequence and to the specified torque 30 N·m.
- (4) Position the water manifold in place and finger tighten the mounting nuts.
- (5) Tighten the fasteners to the specified torque 12 N·m.
- (6) Install exhaust manifold and turbocharger assembly.
- (7) Install charge air cooler hose to intake manifold.
- (8) Connect the battery negative cable.
- (9) Start engine and check for leaks.

SPECIFICATIONS

TORQUE SPECIFICATIONS

Description	Torque
EGR	
Attaching Nuts	19 N·m
EGR	
Tube Nut	34 N·m
EGR	
Tube Flange Bolts	26 N·m
Exhaust Manifold	
Nuts	30 N·m
Exhaust Manifold	
Heat Shield Nuts	11 N·m
Exhaust Pipe	
Support Clamp Bolts	22.5 N·m
Exhaust Pipe	
Support Clamp Screw	22.5 N·m
Intake Manifold	
Nuts	30 N·m
Muffler-to-Exhaust Pipe	
Clamp Nuts	43 N·m
Tail Pipe Clamp	
Hanger bolt	22.5 N·m
Turbocharger-to-Exhaust manifold	
Nuts	27 N·m
Turbocharger	
Oil Feed Line	27.4 N·m

SPECIFICATIONS (Continued)

Description	Torque
Turbocharger Down Pipe-to-Exhaust Pipe	
Bolts/Nuts	22.5 N·m
Turbocharger Down Pipe-to-Turbocharger	
Bolts	27 N·m

FRAME AND BUMPERS

CONTENTS

	page		page
BUMPERS	1	FRAME	4

BUMPERS

INDEX

	page		page
REMOVAL AND INSTALLATION		REAR BUMPER FASCIA	2
FRONT BUMPER/FASCIA	1	REAR BUMPER	3

REMOVAL AND INSTALLATION

FRONT BUMPER/FASCIA

REMOVAL

The Grand Cherokee front bumper is actually a bumper fascia incorporated with a lower welded crossmember. The lower crossmember is a fixed welded structure. To replace the crossmember a frame machine should be used to correctly align the crossmember to the unibody.

- (1) Remove grille screws at grille opening reinforcement (GOR) (Fig. 1).
- (2) If equipped, remove brush guard.
- (3) Unsnap lower clips at grille. Remove grille from (GOR).
- (4) Remove turn signals, side markers and headlamps. Refer to Group 8L, Lamps for service information.
- (5) Remove the retainers at the front fascia (Fig. 2).
- (6) Remove the plastic rivets at each front wheel well (Fig. 3).
- (7) Slide the fascia off of the retainer pegs at the side of the fender attach brackets. Using a small screwdriver, pull up on locating tangs under turn signal mounting location.
- (8) Remove the fascia from the vehicle.

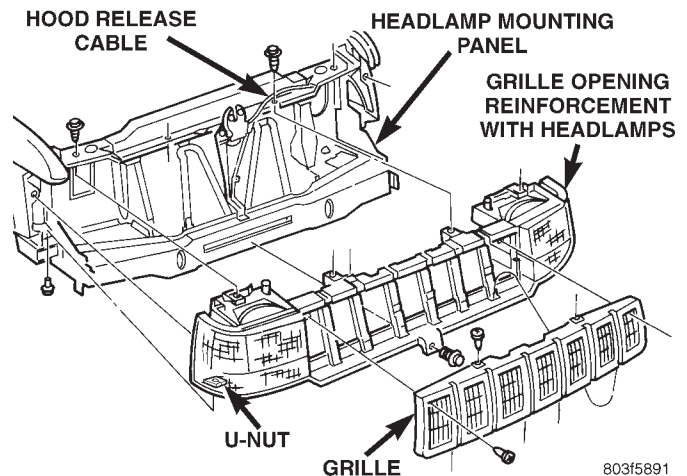


Fig. 1 Grille Removal

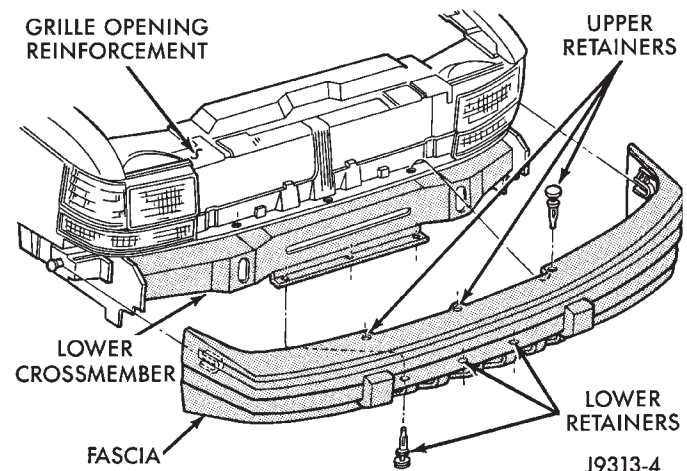
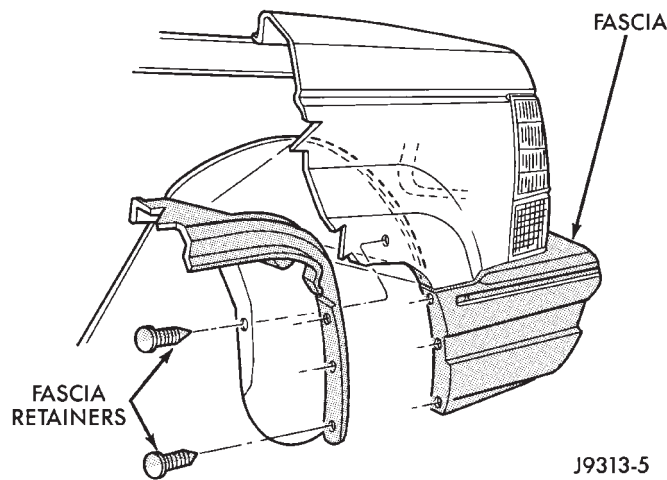


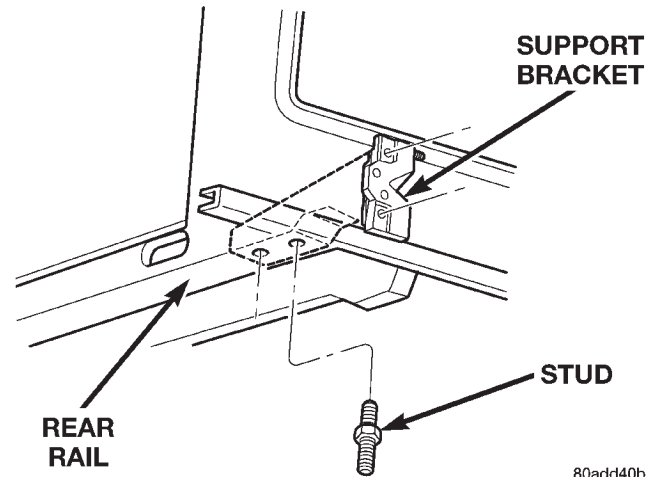
Fig. 2 Lower Fascia Removal

REMOVAL AND INSTALLATION (Continued)**Fig. 3 Wheel Well Retainers****INSTALLATION**

- (1) Reverse removal procedure.

REAR BUMPER FASCIA**REMOVAL**

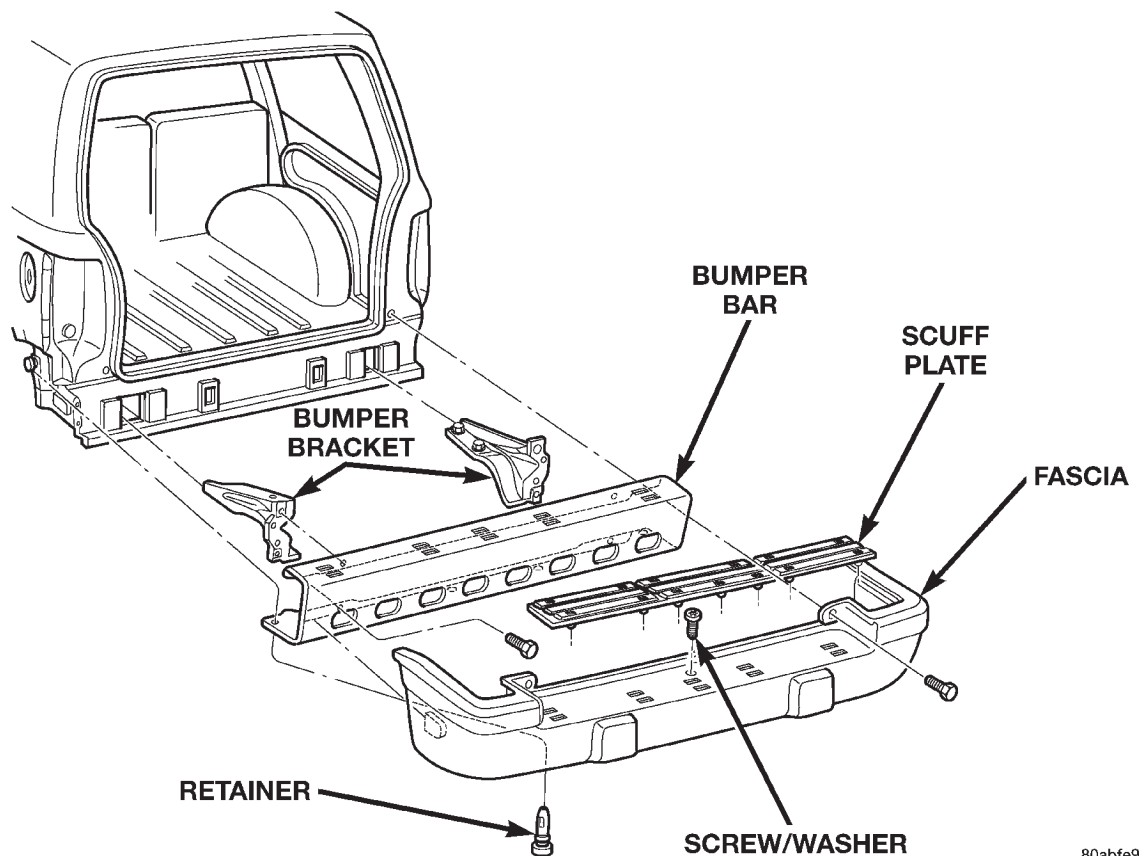
- (1) Raise and support the rear of the vehicle.
- (2) Remove the upper scuff pad from fascia.
- (3) Remove the lower retainers from fascia (Fig. 5).

**Fig. 4 Bumper Support Bracket**

- (4) Remove the push-in retainers located at the rear wheel well on each side.
- (5) Remove the fascia from the bumper.

INSTALLATION

- (1) Reverse the removal procedure.

**Fig. 5 Rear Bumper**

REMOVAL AND INSTALLATION (Continued)**REAR BUMPER****REMOVAL**

- (1) Remove trailer hitch, if equipped.
- (2) Raise and support the rear of the vehicle.
- (3) Support the bumper.
- (4) Remove push-in retainers at each side rear wheel well.
- (5) Remove the studs that attach the bumper support brackets to the rear rails (Fig. 4).
- (6) Slide the bumper beam/fascia off of the retainer pegs on the side of the lower quarter panel.
- (7) Remove the beam/fascia from the vehicle.
- (8) Remove the bumper support brackets from the bumper (Fig. 5).
- (9) Remove the upper scuff pad from the bumper fascia by squeezing fasteners and pushing through slots.

(10) Remove the lower retainers from the bumper fascia.

- (11) Remove the bumper fascia from the bumper

INSTALLATION

- (1) Install brackets onto bumper beam.
- (2) Install beam/brackets onto vehicle rails finger-tight.
- (3) Install fascia onto bumper assembly.
- (4) Check gaps and fit. Adjust as necessary. Tighten bolts to 56 N·m (41 ft-lbs) torque.
- (5) Install scuff pad.
- (6) If removed, install the trailer hitch.

FRAME

INDEX

	page		page
GENERAL INFORMATION		REAR TOW HOOK	6
GENERAL INFORMATION	4	TRAILER HITCH	6
REMOVAL AND INSTALLATION		TRANSFER CASE SKID PLATE	5
FRONT SKID PLATE	5	SPECIFICATIONS	
FRONT TOW HOOK	4	TORQUE SPECIFICATIONS	12
FUEL TANK SKID PLATE	5	VEHICLE DIMENSIONS	6

GENERAL INFORMATION

GENERAL INFORMATION

Jeep Grand Cherokee vehicles do not have a conventional frame. They are constructed as a unitized body and frame. Jeep unibodies are constructed from special high-strength steel and coated metals. This process reduces weight and provides strength to withstand the forces applied against structural members. The structural members provide a unibody that has great structural strength.

REMOVAL AND INSTALLATION

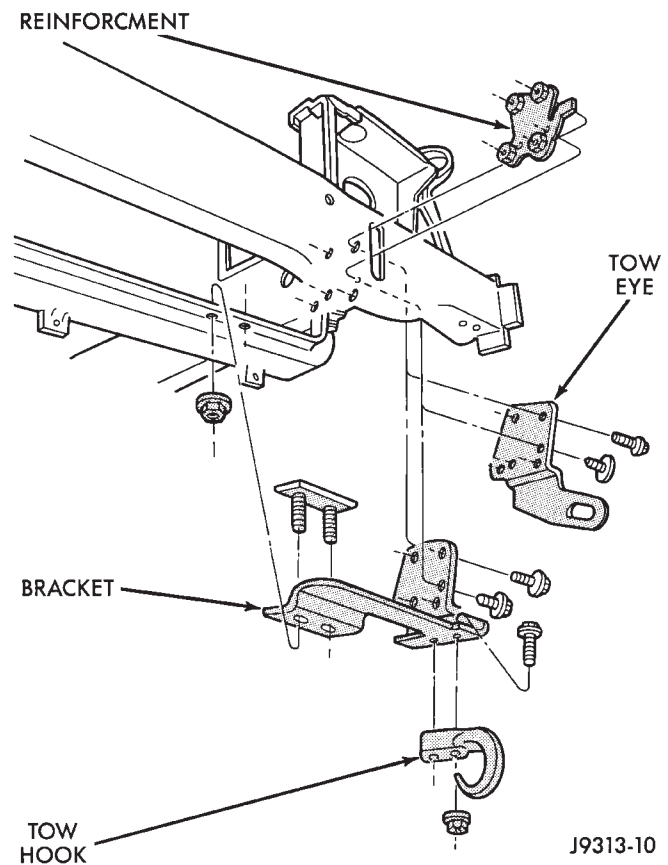
FRONT TOW HOOK

REMOVAL

- (1) Remove grille and fascia.
- (2) Remove the nuts and bolts that attach the tow hooks to the lower crossmember (Fig. 1).
- (3) Remove the tow hooks from the lower crossmember.

INSTALLATION

- (1) Attach tow hook to bracket. Tighten nuts to 95 N·m (70 ft. lbs.) torque.
- (2) Position tow eye bracket at crossmember. Insert bolts thru the bracket and into the reinforcement.
- (3) Position the tow hooks at the lower crossmember.
- (4) Install stud plate from top of crossmember, thru the crossmember and bracket. Tighten all nuts to 67 N·m (50 ft. lbs.) torque.
- (5) Install fascia and grille.



J9313-10

Fig. 1 Front Tow Hook

REMOVAL AND INSTALLATION (Continued)

FRONT SKID PLATE

REMOVAL

- (1) Position a support under skid plate.
- (2) Remove the bolts that attach skid plate to frame (Fig. 2).
- (3) Lower the skid plate.

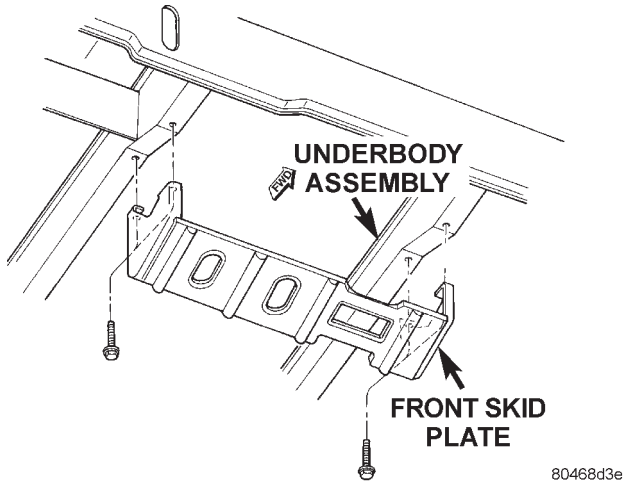


Fig. 2 Front Skid Plate

INSTALLATION

- (1) Position the skid plate on a support.
- (2) Raise it into position
- (3) Install the bolts. Tighten the bolts to 54 N·m (40 ft. lbs.) torque.

TRANSFER CASE SKID PLATE

REMOVAL

- (1) Support skid plate.
- (2) Remove bolts that attach skid plate to transmission support crossmember and frame sill (Fig. 3).
- (3) Remove support and skid plate from vehicle.

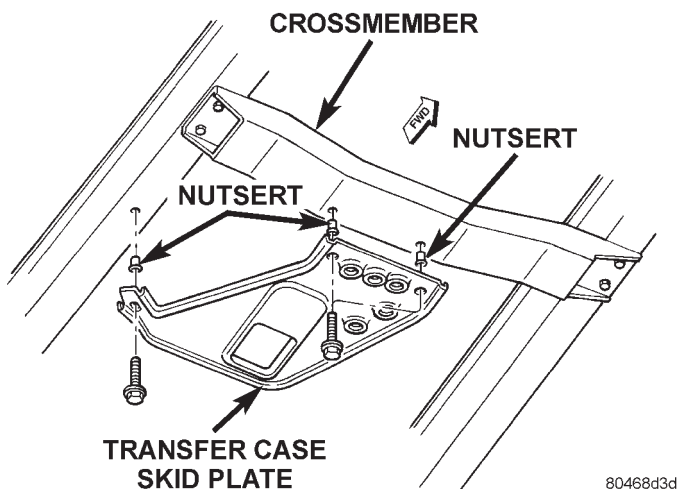


Fig. 3 Transfer Case Skid

INSTALLATION

- (1) Install nutserts, if removed.
- (2) Position and support skid plate at the frame sill and transmission support crossmember.
- (3) Attach skid plate to frame sill and crossmember with the bolts. Tighten bolts to 27 N·m (20 ft. lbs) torque.

FUEL TANK SKID PLATE

REMOVAL

- (1) Remove trailer hitch.
- (2) Position a support under the fuel tank skid plate.
- (3) Remove nuts attaching skid plate to frame rails (Fig. 4).
- (4) Lower skid plate and remove support.

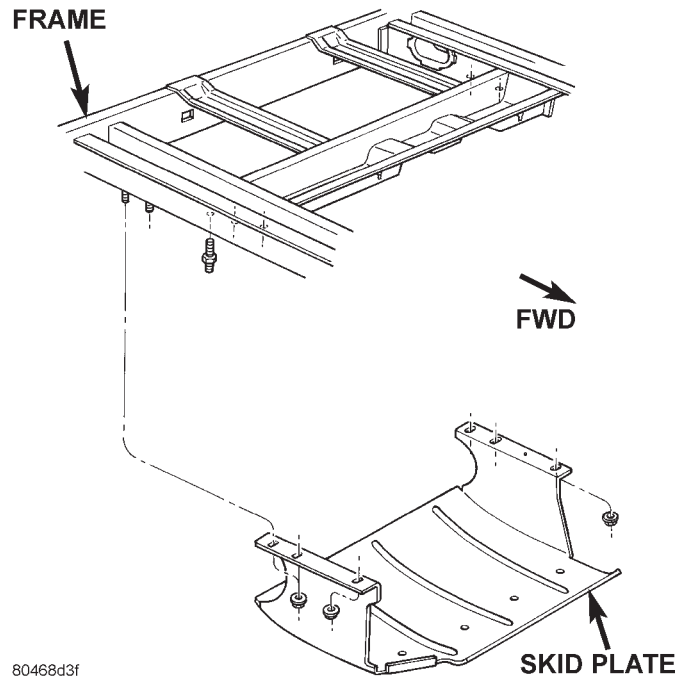


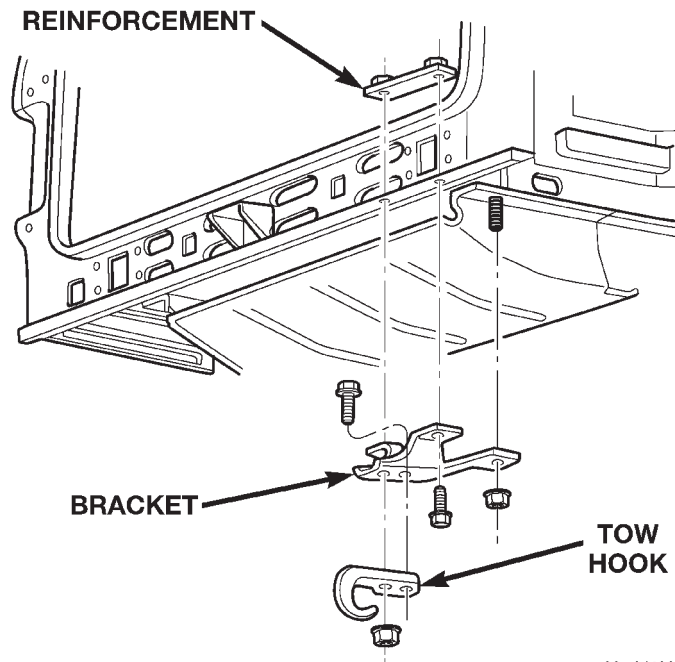
Fig. 4 Fuel Tank Skid Plate

INSTALLATION

- (1) Position skid plate on a support and raise into position.
- (2) Install nuts attaching skid plate to frame rails. Tighten nuts to 74 N·m (55 ft. lbs.) torque.
- (3) Remove support.
- (4) Install trailer hitch.

REMOVAL AND INSTALLATION (Continued)**REAR TOW HOOK****REMOVAL**

- (1) Remove the nuts and bolts that attach the tow hook to the lower crossmember (Fig. 5).
- (2) Remove the tow hook from the lower crossmember.

**Fig. 5 Rear Tow Hook****INSTALLATION**

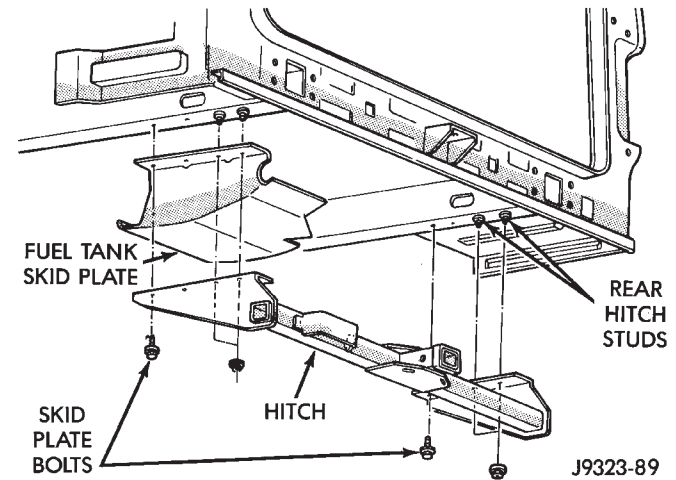
- (1) Attach tow hook to bracket. Tighten nut to 95 N·m (70 ft. lbs.) torque.
- (2) Position reinforcement plate on top of body lip.
- (3) Install the bolts and nuts that attach tow hook. Tighten nut to 95 N·m (70 ft. lbs.) torque.

TRAILER HITCH**REMOVAL**

- (1) If necessary, remove trailer tow wire harness connector from hitch.
- (2) Support hitch.
- (3) Remove nuts that attach the towing tube to frame sills (Fig. 6).

NOTE: Reinforcement brackets are retained on frame sills with 4 studs.

- (4) Remove bolts from plate bracket and vehicle rear crossmember. Lower support and hitch.

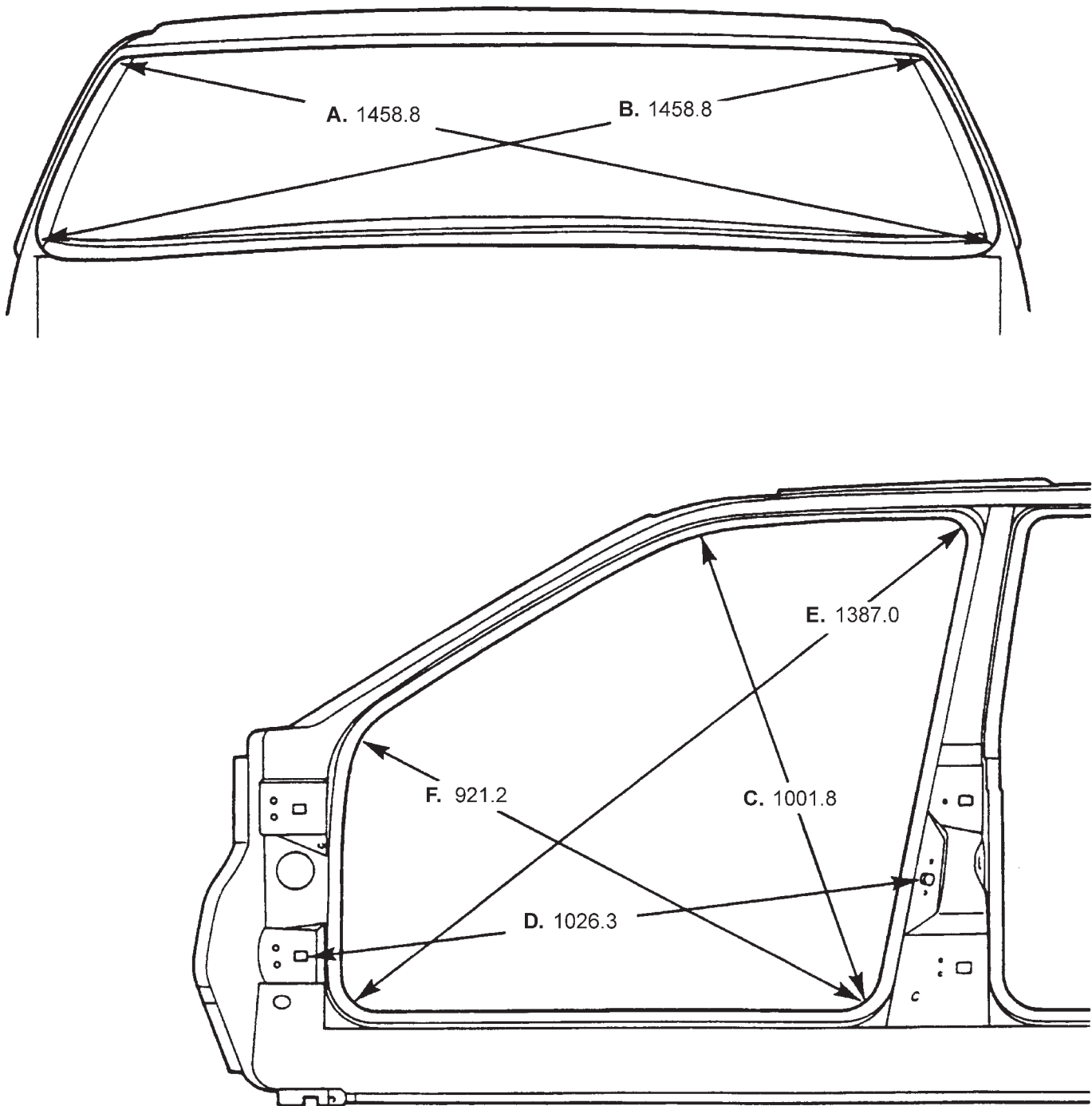
**Fig. 6 Trailer Hitch****INSTALLATION**

- (1) Place hitch on a lifting device. Raise, position hitch at proper location and support it.
- (2) Loosely install nuts that attach towing tube to vehicle frame sills.
- (3) Position plate bracket and install attaching bolts through vehicle rear crossmember.
- (4) Tighten all attaching bolts/nuts.
- (5) Remove support and, if removed, attach trailer wire harness connector to hitch.

SPECIFICATIONS**VEHICLE DIMENSIONS**

Frame dimensions are listed in metric scale. All dimensions are from center to center of Principal Locating Point (PLP), or from center to center of PLP and fastener location (Fig. 7), (Fig. 8), (Fig. 9), (Fig. 10) and (Fig. 11)

SPECIFICATIONS (Continued)

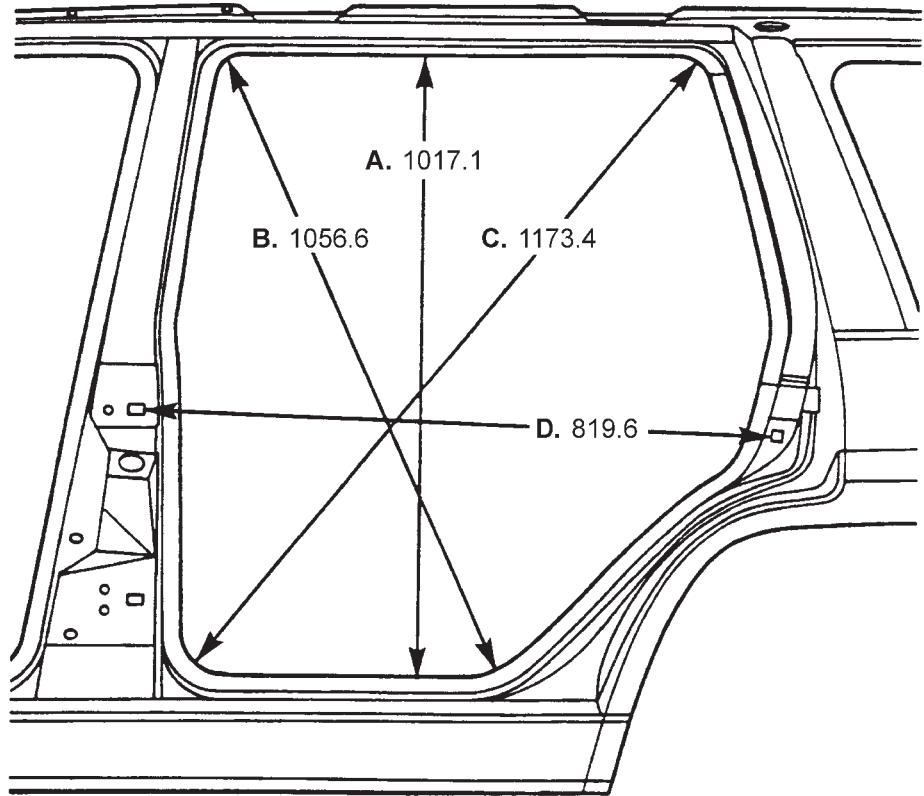


- A. & B. Center of radius at bottom to center of radius at top
- C. Center of front door lower rear corner radius to center of A-pillar radius.
- D. Center of door hinge mount to center of door striker mount.
- E. Center of radius at bottom front to center of radius at top rear.
- F. Center of radius at bottom rear to center of radius at lower A-pillar.

Fig. 7 Vehicle Dimensions—Front/Side View

SPECIFICATIONS (Continued)

- A. Quarter panel to Front Outer Body side upper and lower seam.
- B. Center of front upper door radius to center of rear lower door radius.
- C. Center of front lower door radius to center of rear upper door radius.
- D. Rear door hinge mount to rear door striker mount.



- A. Center of upper and lower rear quarter window opening.
- B. Center of radius front lower corner to center of radius rear upper corner.
- C. Center of radius front upper corner to center of radius rear lower corner.

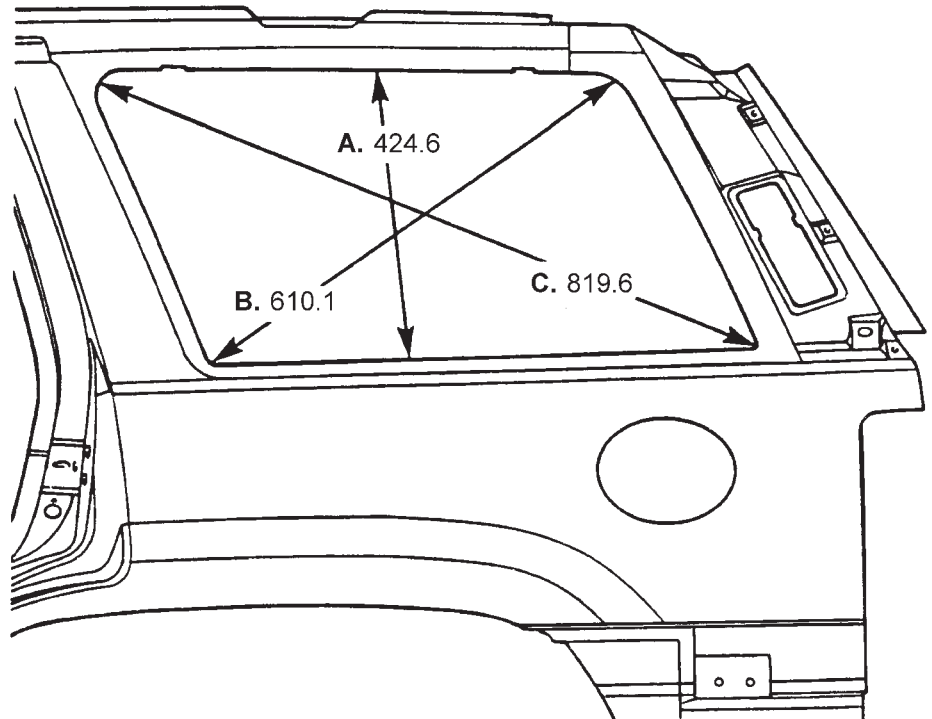
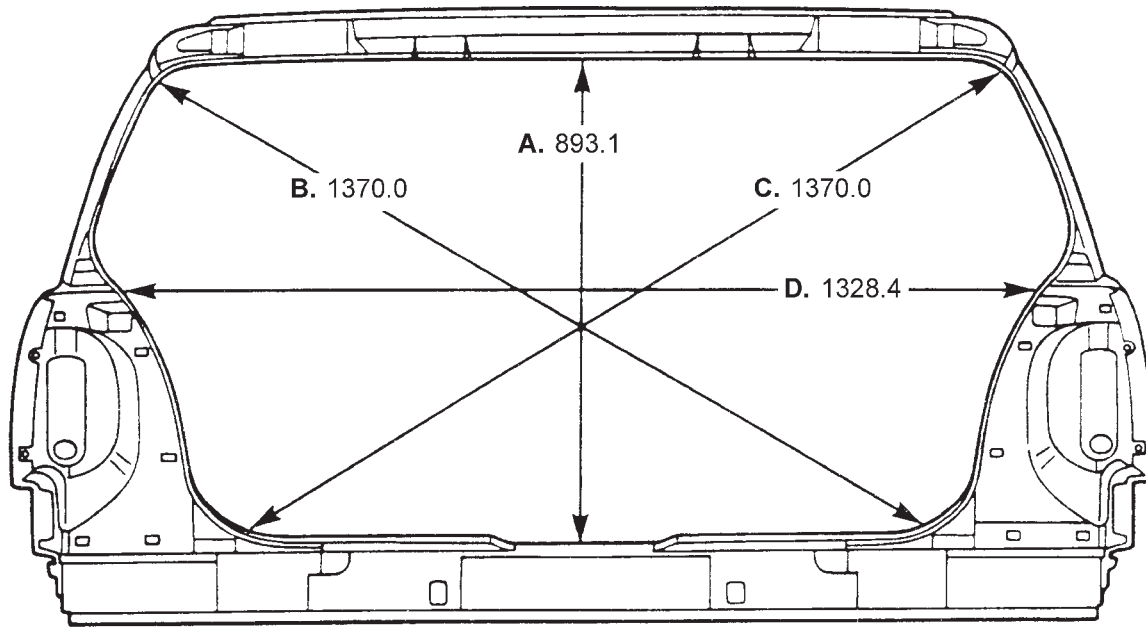


Fig. 8 Vehicle Dimensions—Side View

SPECIFICATIONS (Continued)



- A. Center of upper liftgate opening to liftgate striker mount.
- B. & C. Center of radius upper corner to center of radius lower corner.
- D. Distance between outer quarter panel to tail lamp mounting panel to inner quarter panel seams.

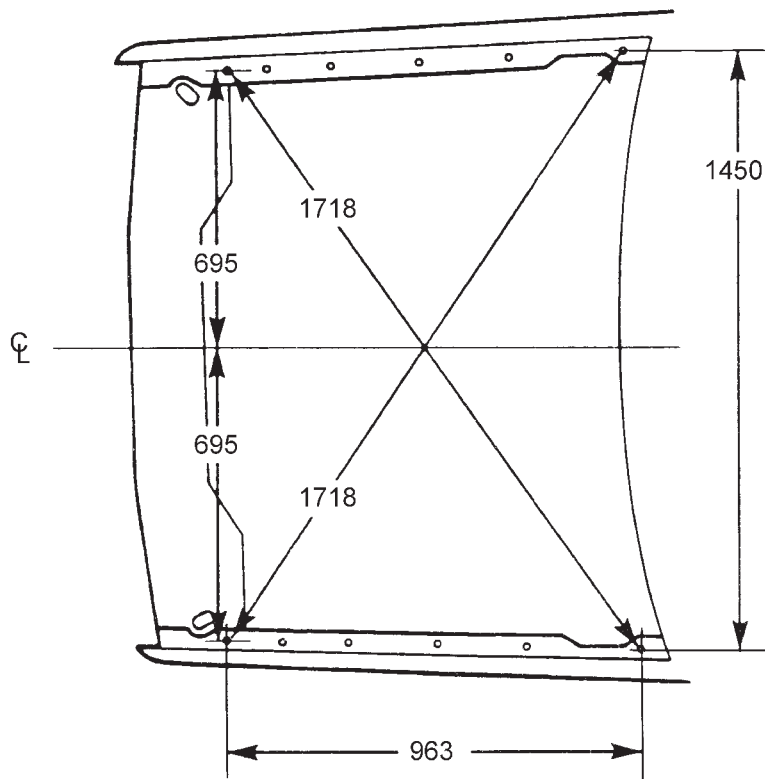
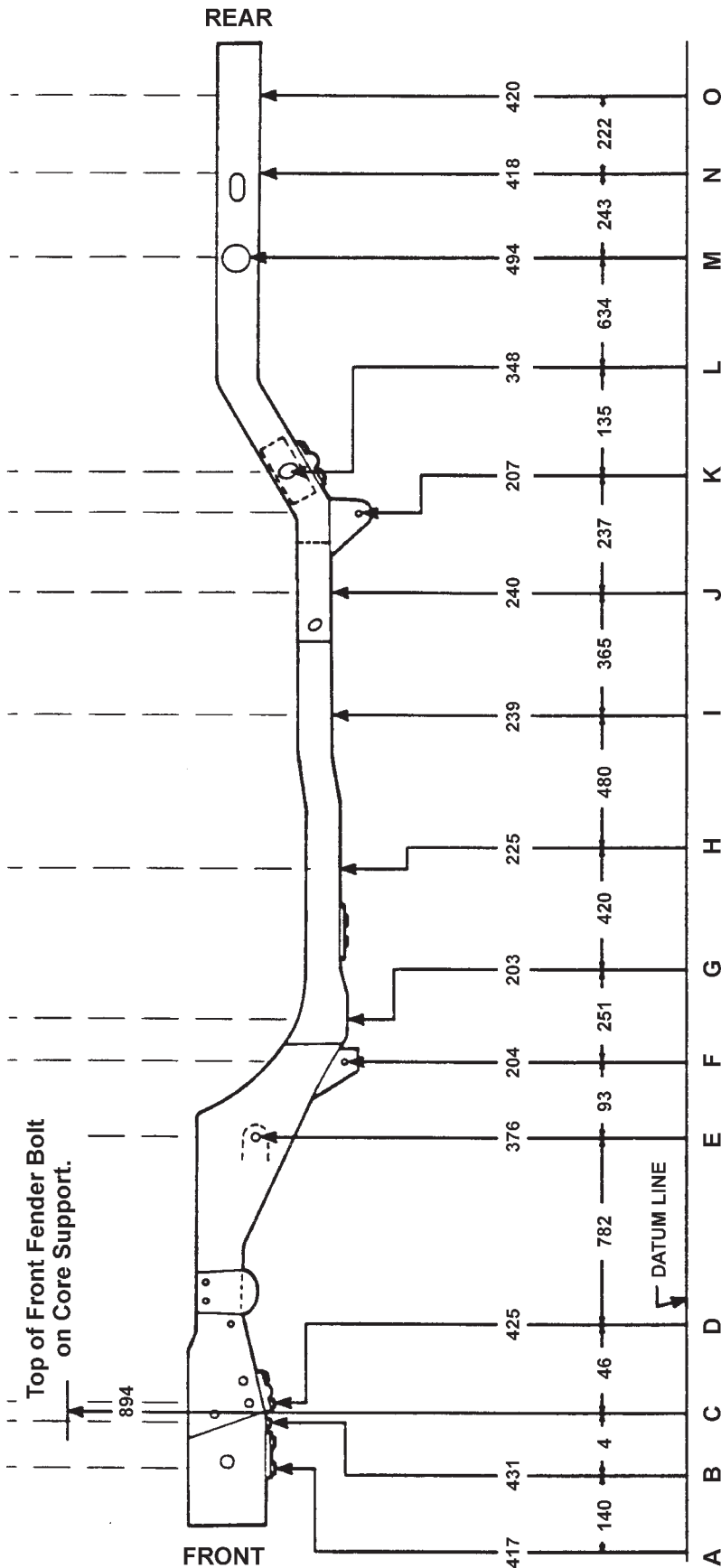


Fig. 9 Vehicle Dimensions—Rear View And Engine Compartment

SPECIFICATIONS (Continued)



OVERALL DATUM LENGTHS

- B to G = 1176mm
- G to J = 1265mm
- J to N = 1249mm

HOLE DIAMETERS

- A = Bolt
- B = 14mm
- C = Front Fender Bolt
- D = Bolt
- E = Bolt
- F = Bolt
- G = 19mm x 25mm
- H = 19mm
- I = 19mm x 25mm
- J = 19mm
- K = Bolt
- L = Bolt
- M = Bolt
- N = 19mm x 25mm
- O = 13mm

SIDE VIEW

Datum Height Dimensions are PERPENDICULAR to Datum Plane.
Datum Length Dimensions are PARALLEL to Centerline of Vehicle,
and are Measured Center-to-Center.

All measurements in millimeter.

801834a7

Fig. 10 Frame Dimensions—Side View

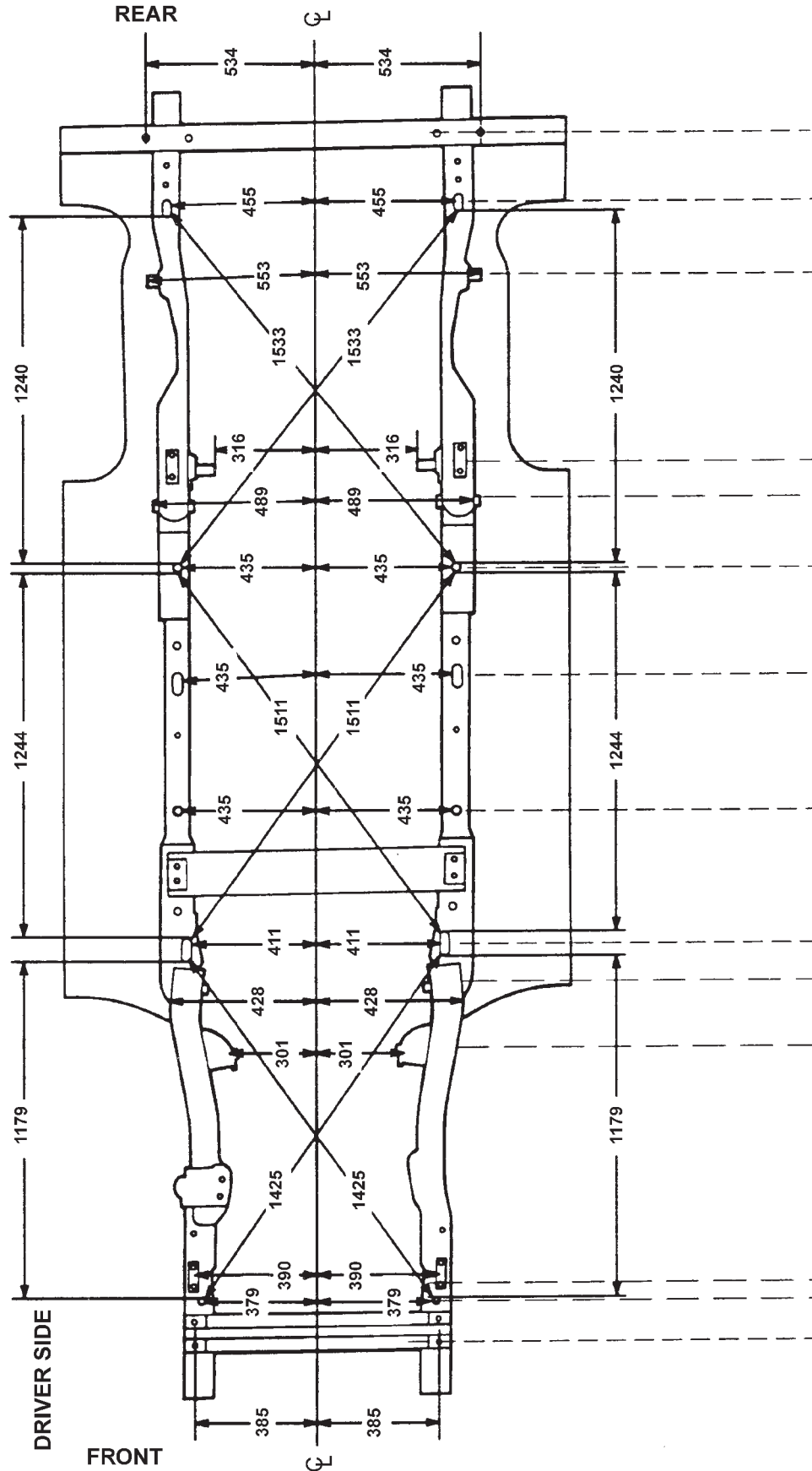
SPECIFICATIONS (Continued)

All measurements in millimeter.

BOTTOM VIEW

BOTTOM VIEW POINT-TO-POINT DIMENSIONS ARE TAKEN WITH TRAM BAR POINTERS SET AT EQUAL LENGTHS.

Bolts and Studs are Measured to Center. Holes are Measured to Closest Edge.



80183-4a8

Fig. 11 Frame Dimensions—Bottom View

SPECIFICATIONS (Continued)**TORQUE SPECIFICATIONS**

DESCRIPTION	TORQUE
Front Tow Hook Nut	100 N·m (74 ft. lbs.)
Front Skid Plate Bolt54 N·m (40 ft. lbs.)
Fuel Tank Skid Plate Nuts74 N·m (55 ft. lbs.)
Fuel Tank Skid Plate Mtg Studs108 N·m (80 ft. lbs.)
Rear Bumper Bolt56 N·m (41 ft. lbs.)
Rear Tow Hook Nut	100 N·m (74 ft. lbs.)
Trailer Hitch Nuts/Bolts74 N·m (55 ft. lbs.)
Transfer Case Skid Plate Bolts27 N·m (20 ft. lbs.)

FUEL SYSTEM

CONTENTS

	page		page
FUEL DELIVERY SYSTEM	3	GENERAL INFORMATION	1
FUEL INJECTION SYSTEM	25		

GENERAL INFORMATION

INDEX

	page		page
GENERAL INFORMATION		GASOLINE/OXYGENATE BLENDS	1
FUEL REQUIREMENTS	1	INTRODUCTION	1

GENERAL INFORMATION

INTRODUCTION

Throughout this group, references may be made to a particular vehicle by letter or number designation. A chart showing the breakdown of these designations is included in the Introduction Section at the front of this service manual.

The Evaporation Control System, is also considered part of the fuel system. The system reduces the emission of fuel vapor into the atmosphere.

The description and function of the Evaporation Control System is found in Group 25 of this manual.

FUEL REQUIREMENTS

Your vehicle was designed to meet all emission regulations and provide excellent fuel economy when using high quality unleaded gasoline.

Use unleaded gasolines having a minimum posted octane of 87.

If your vehicle develops occasional light spark knock (ping) at low engine speeds this is not harmful. However; continued heavy knock at high speeds can cause damage and should be reported to your dealer immediately. Engine damage as a result of heavy knock operation may not be covered by the new vehicle warranty.

In addition to using unleaded gasoline with the proper octane rating, those that contain detergents, corrosion and stability additives are recommended. Using gasolines that have these additives will help improve fuel economy, reduce emissions, and maintain vehicle performance.

Poor quality gasoline can cause problems such as hard starting, stalling, and stumble. If you experience these problems, try another brand of gasoline before considering service for the vehicle.

GASOLINE/OXYGENATE BLENDS

Some fuel suppliers blend unleaded gasoline with materials that contain oxygen such as alcohol, MTBE (Methyl Tertiary Butyl Ether) and ETBE (Ethyl Tertiary Butyl Ether). Oxygenates are required in some areas of the country during winter months to reduce carbon monoxide emissions. The type and amount of oxygenate used in the blend is important.

The following are generally used in gasoline blends:

Ethanol - (Ethyl or Grain Alcohol) properly blended, is used as a mixture of 10 percent ethanol and 90 percent gasoline. Gasoline blended with ethanol may be used in your vehicle.

MTBE/ETBE - Gasoline and MTBE (Methyl Tertiary Butyl Ether) blends are a mixture of unleaded gasoline and up to 15 percent MTBE. Gasoline and ETBE (Ethyl Tertiary Butyl Ether) are blends of gasoline and up to 17 percent ETBE. Gasoline blended with MTBE or ETBE may be used in your vehicle.

Methanol - Methanol (Methyl or Wood Alcohol) is used in a variety of concentrations blended with unleaded gasoline. You may encounter fuels containing 3 percent or more methanol along with other alcohols called cosolvents.

DO NOT USE GASOLINES CONTAINING METHANOL.

GENERAL INFORMATION (Continued)

Use of methanol/gasoline blends may result in starting and driveability problems and damage critical fuel system components.

Problems that are the result of using methanol/gasoline blends are not the responsibility of Chrysler Corporation and may not be covered by the vehicle warranty.

Reformulated Gasoline

Many areas of the country are requiring the use of cleaner-burning fuel referred to as **Reformulated Gasoline**. Reformulated gasolines are specially blended to reduce vehicle emissions and improve air quality.

Chrysler Corporation strongly supports the use of reformulated gasolines whenever available. Although your vehicle was designed to provide optimum performance and lowest emissions operating on high quality unleaded gasoline, it will perform equally well and produce even lower emissions when operating on reformulated gasoline.

Materials Added to Fuel

Indiscriminate use of fuel system cleaning agents should be avoided. Many of these materials intended for gum and varnish removal may contain active solvents of similar ingredients that can be harmful to fuel system gasket and diaphragm materials.

FUEL DELIVERY SYSTEM

INDEX

	page		page
DESCRIPTION AND OPERATION		SERVICE PROCEDURES	
FUEL DELIVERY SYSTEM	3	FUEL SYSTEM PRESSURE RELEASE PROCEDURE	10
FUEL FILTER/FUEL PRESSURE REGULATOR	4	FUEL TUBES/LINES/HOSES AND CLAMPS	11
FUEL GAUGE SENDING UNIT	4	QUICK-CONNECT FITTINGS	11
FUEL INJECTORS	5	REMOVAL AND INSTALLATION	
FUEL PUMP MODULE	4	ACCELERATOR PEDAL	22
FUEL PUMP	4	FUEL FILTER/FUEL PRESSURE REGULATOR	14
FUEL RAIL—4.0L ENGINE	6	FUEL GAUGE SENDING UNIT	16
FUEL RAIL—5.2L/5.9L ENGINES	6	FUEL INJECTOR RAIL—4.0L ENGINE	19
FUEL TANK FILLER TUBE CAP	6	FUEL INJECTOR RAIL—5.2L/5.9L ENGINES	17
FUEL TANK	5	FUEL INJECTOR(S)	19
QUICK-CONNECT FITTINGS	6	FUEL PUMP INLET FILTER	16
ROLLOVER VALVE(S)	5	FUEL PUMP MODULE	15
DIAGNOSIS AND TESTING		FUEL TANK FILLER TUBE CAP	22
FUEL GAUGE SENDING UNIT	10	FUEL TANK	20
FUEL INJECTOR TEST	10	THROTTLE CABLE	22
FUEL PRESSURE LEAK DOWN TEST	8	SPECIFICATIONS	
FUEL PUMP AMPERAGE TEST	9	FUEL SYSTEM PRESSURE	24
FUEL PUMP CAPACITY TEST	7	FUEL TANK CAPACITY	24
FUEL PUMP PRESSURE TEST—ALL ENGINES WITH PRESSURE TEST PORT	7	TORQUE CHART	24
		VECI LABEL	24

DESCRIPTION AND OPERATION

FUEL DELIVERY SYSTEM

The fuel delivery system consists of:

- the fuel pump module containing the electric fuel pump, fuel filter/fuel pressure regulator, fuel gauge sending unit (fuel level sensor) and a separate fuel filter located at bottom of pump module
 - fuel tubes/lines/hoses
 - quick-connect fittings
 - fuel injector rail
 - fuel injectors
 - fuel tank
 - fuel tank filler/vent tube assembly
 - fuel tank filler tube cap
 - accelerator pedal
 - throttle cable

Fuel is returned through the fuel pump module and back into the fuel tank through the fuel filter/fuel pressure regulator. A separate fuel return line from the engine to the tank is not used.

The fuel tank assembly consists of: the fuel tank, fuel pump module assembly, fuel pump module locknut/gasket, and rollover valve (refer to Group 25,

Emission Control System for rollover valve information).

A fuel filler/vent tube assembly using a pressure/vacuum fuel filler cap is used. The fuel filler tube contains a spring-loaded flap (door) located below the fuel fill cap. The flap is used as a secondary way of sealing the fuel tank if the fuel fill cap has not been properly tightened. The flap is used as part of the EVAP monitor system when the vehicle is equipped with a Leak Detection Pump (LDP). The flap will be installed to all fuel filler tubes (equipped/not equipped with LDP and EVAP monitor system).

Also to be considered part of the fuel system is the evaporation control system. This is designed to reduce the emission of fuel vapors into the atmosphere. The description and function of the Evaporative Control System is found in Group 25, Emission Control Systems.

Both fuel filters (at bottom of fuel pump module and within fuel pressure regulator) are designed for extended service. They do not require normal scheduled maintenance. Filters should only be replaced if a diagnostic procedure indicates to do so.

DESCRIPTION AND OPERATION (Continued)

FUEL PUMP MODULE

The fuel pump module is installed in the top of the fuel tank (Fig. 1) or (Fig. 2). The fuel pump module contains the following components:

- A combination fuel filter/fuel pressure regulator
- A separate fuel pick-up filter (strainer)
- An electric fuel pump
- A threaded locknut to retain module to tank
- A gasket between tank flange and module
- Fuel gauge sending unit (fuel level sensor)
- Fuel supply tube (line) connection

The fuel gauge sending unit, pick-up filter and fuel filter/fuel pressure regulator may be serviced separately. If the electrical fuel pump requires service, the entire fuel pump module must be replaced.

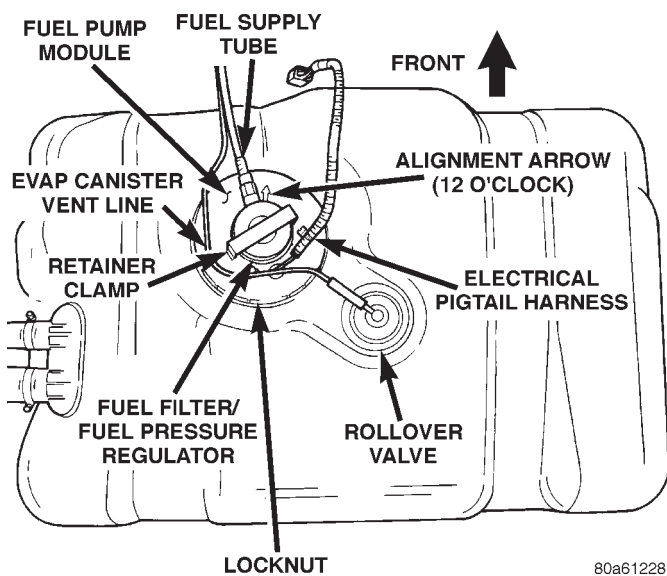


Fig. 1 Fuel Tank/Fuel Pump Module (Top View)

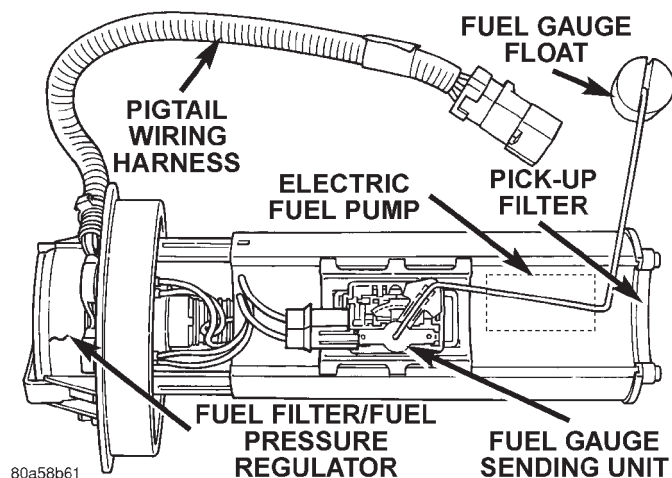


Fig. 2 Fuel Pump Module Components

FUEL PUMP

The fuel pump used in this system has a permanent magnet electric motor. The pump is part of the

fuel pump module. Fuel is drawn in through a filter at the bottom of the module and pushed through the electric motor gearset to the pump outlet.

Check Valve Operation: The pump outlet contains a one-way check valve to prevent fuel flow back into the tank and to maintain fuel supply line pressure (engine warm) when pump is not operational. It is also used to keep the fuel supply line full of gasoline when pump is not operational. After the vehicle has cooled down, fuel pressure may drop to 0 psi (cold fluid contracts), but liquid gasoline will remain in fuel supply line between the check valve and fuel injectors. **Fuel pressure that has dropped to 0 psi on a cooled down vehicle (engine off) is a normal condition.** Refer to the Fuel Pressure Leak Down Test in this group for more information.

Voltage to operate the electric pump is supplied through the fuel pump relay.

FUEL GAUGE SENDING UNIT

The fuel gauge sending unit (fuel level sensor) is attached to the side of the fuel pump module. The sending unit consists of a float, an arm, and a variable resistor (track). The resistor track is used to send electrical signals to the Powertrain Control Module (PCM) for fuel gauge operation and for OBD II emission requirements.

For fuel gauge operation: As fuel level increases, the float and arm move up. This decreases the sending unit resistance, causing the fuel gauge to read full. As fuel level decreases, the float and arm move down. This increases the sending unit resistance causing the fuel gauge to read empty.

After this fuel level signal is sent to the PCM, the PCM will transmit the data across the CCD bus circuits to the instrument panel. Here it is translated into the appropriate fuel gauge level reading.

For OBD II emission monitor requirements: A voltage signal is sent from the resistor track on the sending unit to the PCM to indicate fuel level. The purpose of this feature is to prevent the OBD II system from recording/setting false misfire and fuel system monitor trouble codes. The feature is activated if the fuel level in the tank is less than approximately 15 percent of its rated capacity. If equipped with a Leak Detection Pump (EVAP system monitor), this feature will also be activated if the fuel level in the tank is more than approximately 85 percent of its rated capacity.

FUEL FILTER/FUEL PRESSURE REGULATOR

A combination fuel filter and fuel pressure regulator is used on all engines. It is located on the top of fuel pump module (Fig. 1). A separate frame mounted fuel filter is not used with any engine.

DESCRIPTION AND OPERATION (Continued)

Fuel Pressure Regulator Operation: The pressure regulator is a mechanical device that is not controlled by engine vacuum or the Powertrain Control Module (PCM).

The regulator is calibrated to maintain fuel system operating pressure of approximately 339 kPa \pm 34 kPa (49.2 psi \pm 5 psi) at the fuel injectors. It contains a diaphragm, calibrated springs and a fuel return valve. The internal fuel filter is also part of the assembly.

Fuel is supplied to the filter/regulator by the electric fuel pump through an opening tube at the bottom of filter/regulator (Fig. 3).

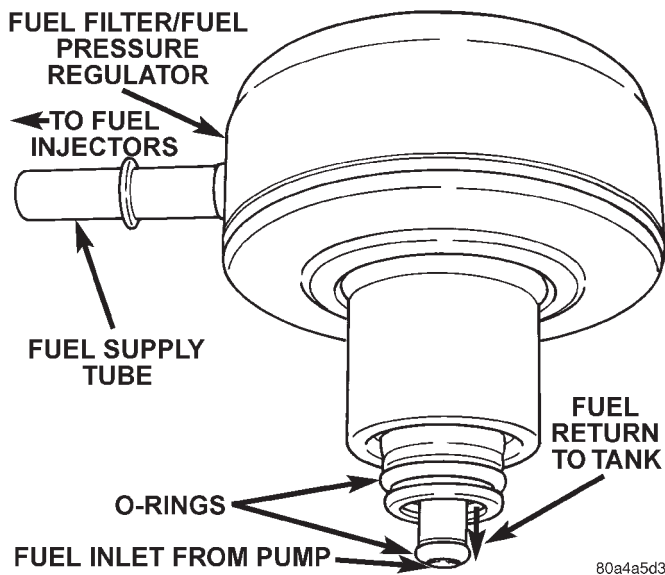


Fig. 3 Fuel Filter/Fuel Pressure Regulator

The regulator acts as a check valve to maintain some fuel pressure when the engine is not operating. This will help to start the engine. A second check valve is located at the outlet end of the electric fuel pump. **Refer to Fuel Pump—Description and Operation for more information. Also refer to the Fuel Pressure Leak Down Test and the Fuel Pump Pressure Tests.**

If fuel pressure at the pressure regulator exceeds approximately 49 psi, an internal diaphragm closes and excess fuel is routed back into the tank through the pressure regulator. A separate fuel return line is not used.

FUEL TANK

All models pass a full 360 degree rollover test without fuel leakage. To accomplish this, fuel and vapor flow controls are required for all fuel tank connections.

All models are equipped with either one or two rollover valves mounted into the top of the fuel tank (or pump module). Refer to Group 25, Emission Control System for rollover valve information.

An evaporation control system is connected to the rollover valve(s) to reduce emissions of fuel vapors into the atmosphere. When fuel evaporates from the fuel tank, vapors pass through vent hoses or tubes to a charcoal canister where they are temporarily held. When the engine is running, the vapors are drawn into the intake manifold. Certain models are also equipped with a self-diagnosing system using a Leak Detection Pump (LDP). Refer to Group 25, Emission Control System for additional information.

ROLLOVER VALVE(S)

Refer to Group 25, Emission Control System for information.

FUEL INJECTORS

The fuel injectors (Fig. 4) are electrical solenoids. The injector contains a pintle that closes off an orifice at the nozzle end. When electric current is supplied to the injector, the armature and needle move a short distance against a spring, allowing fuel to flow out the orifice. Because the fuel is under high pressure, a fine spray is developed in the shape of a pencil stream. The spraying action atomizes the fuel, adding it to the air entering the combustion chamber.

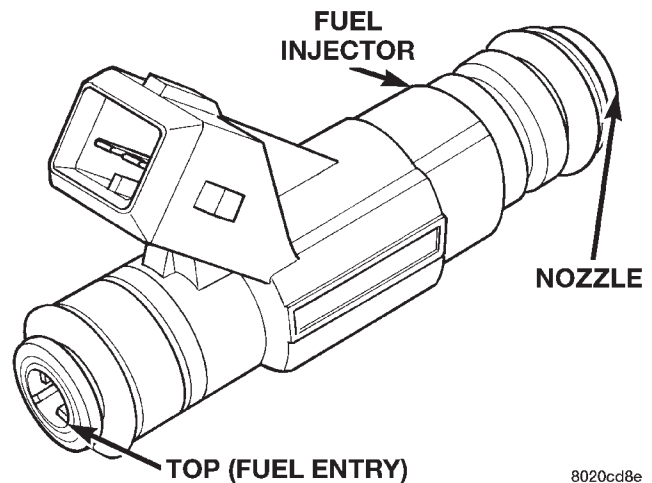


Fig. 4 Fuel Injector—Typical

An individual fuel injector is used for each individual cylinder. The top (fuel entry) end of the injector is attached into an opening on the fuel rail.

The nozzle (outlet) ends of the injectors are positioned into openings in the intake manifold just above the intake valve ports of the cylinder head. The engine wiring harness connector for each fuel injector is equipped with an attached numerical tag (INJ 1, INJ 2 etc.). This is used to identify each fuel injector.

The injectors are energized individually in a sequential order by the powertrain control module (PCM). The PCM will adjust injector pulse width by switching the ground path to each individual injector

DESCRIPTION AND OPERATION (Continued)

on and off. Injector pulse width is the period of time that the injector is energized. The PCM will adjust injector pulse width based on various inputs it receives.

During start up, battery voltage is supplied to the injectors through the ASD relay. When the engine is operating, voltage is supplied by the charging system. The PCM determines injector pulse width based on various inputs.

FUEL RAIL—4.0L ENGINE

The fuel rail supplies the necessary fuel to each individual fuel injector and is mounted to the intake manifold (Fig. 5). The fuel pressure regulator is not mounted to the fuel rail on any 4.0L engine. It is located on the fuel tank mounted fuel pump module. Refer to Fuel Filter/Fuel Pressure Regulator in this group for information.

Depending on vehicle model/engine, the fuel rail may/may not be equipped with a fuel pressure test port. Refer to the Fuel Pump Pressure Test for additional information.

The fuel rail is not repairable.

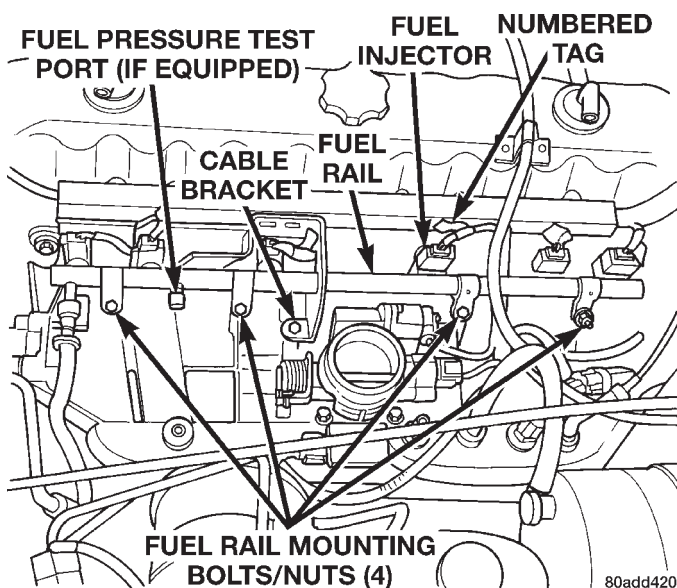


Fig. 5 Fuel Rail—4.0L Engine

FUEL RAIL—5.2L/5.9L ENGINES

The fuel rail supplies the necessary fuel to each individual fuel injector and is mounted to the intake manifold (Fig. 6). The fuel pressure regulator is not mounted to the fuel rail on any 5.2L/5.9L V-8 engine. It is located on the fuel tank mounted fuel pump module. Refer to Fuel Filter/Fuel Pressure Regulator in this group for information.

Depending on vehicle model/engine, the fuel rail may/may not be equipped with a fuel pressure test port. If equipped, it will be located on the left side of

fuel rail. Refer to the Fuel Pump Pressure Test for additional information.

The fuel rail is not repairable.

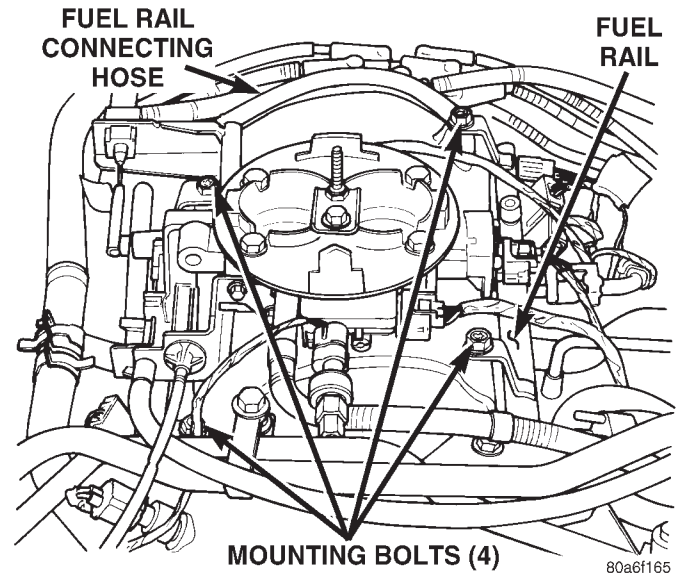


Fig. 6 Fuel Rail—Typical 5.2L/5.9L Engine

CAUTION: 5.2L/5.9L Engines Only: The left and right sections of the fuel rail are connected with a flexible connecting hose. Do not attempt to separate the rail halves at this connecting hose. Due to the design of this connecting hose, it does not use any clamps. Never attempt to install a clamping device of any kind to the hose. When removing the fuel rail assembly for any reason, be careful not to bend or kink the connecting hose.

FUEL TANK FILLER TUBE CAP

The loss of any fuel or vapor out of filler neck is prevented by the use of a pressure-vacuum fuel tank filler tube cap. Relief valves inside cap will release only under significant pressure of 6.58 to 8.44 kPa (1.95 to 2.5 psi). The vacuum release for all fuel filler tube caps is between .97 and 5.0 kPa (.14 and .72 psi). This cap must be replaced by a similar unit if replacement is necessary. This is in order for the system to remain effective.

CAUTION: Remove fuel tank filler tube cap before servicing any fuel system component. This is done to help relieve tank pressure.

QUICK-CONNECT FITTINGS

Different types of quick-connect fittings are used to attach various fuel system components. These are: a single-tab type, a two-tab type or a plastic retainer ring type. Some are equipped with safety latch clips.

DESCRIPTION AND OPERATION (Continued)

Refer to the Removal/Installation section for more information.

CAUTION: The interior components (o-rings, spacers) of quick-connect fitting are not serviced separately, but new pull tabs are available for some types. Do not attempt to repair damaged fittings or fuel lines/tubes. If repair is necessary, replace the complete fuel tube assembly.

DIAGNOSIS AND TESTING

FUEL PUMP PRESSURE TEST—ALL ENGINES WITH PRESSURE TEST PORT

Use this test in conjunction with the Fuel Pump Capacity Test, Fuel Pressure Leak Down Test and Fuel Pump Amperage Test found elsewhere in this group.

Check Valve Operation: The electric fuel pump outlet contains a one-way check valve to prevent fuel flow back into the tank and to maintain fuel supply line pressure (engine warm) when pump is not operational. It is also used to keep the fuel supply line full of gasoline when pump is not operational. After the vehicle has cooled down, fuel pressure may drop to 0 psi (cold fluid contracts), but liquid gasoline will remain in fuel supply line between the check valve and fuel injectors. **Fuel pressure that has dropped to 0 psi on a cooled down vehicle (engine off) is a normal condition.** When the electric fuel pump is activated, fuel pressure should **immediately** (1–2 seconds) rise to specification.

All fuel systems are equipped with a fuel tank module mounted, combination fuel filter/fuel pressure regulator. The fuel pressure regulator is not controlled by engine vacuum.

WARNING: THE FUEL SYSTEM IS UNDER CONSTANT FUEL PRESSURE EVEN WITH THE ENGINE OFF. BEFORE DISCONNECTING FUEL LINE AT FUEL RAIL, THIS PRESSURE MUST BE RELEASED. REFER TO THE FUEL SYSTEM PRESSURE RELEASE PROCEDURE.

(1) Remove protective cap at fuel rail test port. Connect the 0–414 kPa (0–60 psi) fuel pressure gauge (from gauge set 5069) to test port pressure fitting on fuel rail (Fig. 7).

(2) Start and warm engine and note pressure gauge reading. Fuel pressure should be 339 kPa \pm 34 kPa (49.2 psi \pm 5 psi) at idle.

(3) If engine runs, but pressure is below 44.2 psi, check for a kinked fuel supply line somewhere between fuel rail and fuel pump module. If line is not kinked, but specifications for either the Fuel Pump

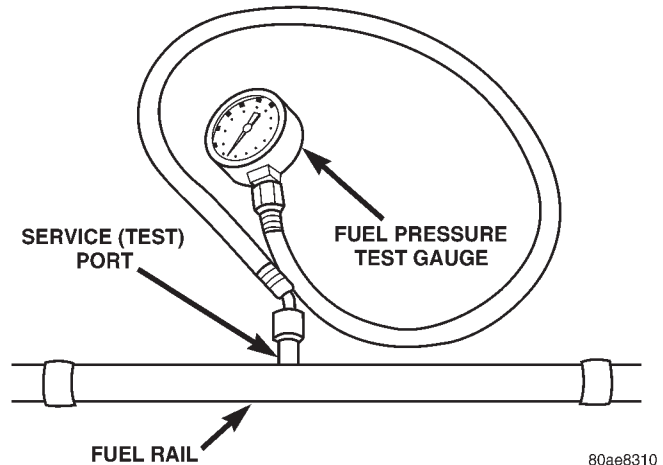


Fig. 7 Fuel Pressure Test Gauge (Typical Gauge Installation at Test Port)

Capacity, Fuel Pump Amperage or Fuel Pressure Leak Down Tests were not met, replace fuel pump module assembly. Refer to Fuel Pump Module Removal/Installation.

(4) If operating pressure is above 54.2 psi, electric fuel pump is OK, but fuel pressure regulator is defective. Replace fuel filter/fuel pressure regulator. Refer to Fuel Filter/Fuel Pressure Regulator Removal/Installation for more information.

(5) Install protective cap to fuel rail test port.

FUEL PUMP CAPACITY TEST

Before performing this test, verify fuel pump pressure by performing the Fuel Pump Pressure Test. Use this test in conjunction with the Fuel Pressure Leak Down Test found elsewhere in this group.

(1) Release fuel system pressure. Refer to the Fuel Pressure Release Procedure in this group.

(2) Disconnect fuel supply line at fuel rail. Refer to Quick-Connect Fittings in the Service Procedures section of this group for procedures. Some engines may require air cleaner housing removal before line disconnection.

(3) Connect appropriate Fuel Line Pressure Test Adapter Tool Hose (number 6631, 6923, 6541 or 6539) into disconnected fuel supply line. Insert other end of Adaptor Tool hose into a graduated container.

(4) Remove fuel fill cap.

(5) To activate fuel pump and pressurize system, obtain DRB scan tool and actuate ASD Fuel System Test.

(6) A good fuel pump will deliver at least 1/4 liter of fuel in 7 seconds. Do not operate fuel pump for longer than 7 seconds with fuel line disconnected as fuel pump module reservoir may run empty.

(a) If capacity is lower than specification, but fuel pump can be heard operating through fuel fill cap opening, check for a kinked/damaged fuel sup-

DIAGNOSIS AND TESTING (Continued)

ply line somewhere between fuel rail and fuel pump module.

(b) If line is not kinked/damaged, and fuel pressure is OK, but capacity is low, replace fuel filter/fuel pressure regulator. The filter/regulator may be serviced separately on certain applications. Refer to Fuel Filter/Fuel Pressure Regulator Removal/Installation for additional information.

(c) If both fuel pressure and capacity are low, replace fuel pump module assembly. Refer to Fuel Pump Module Removal/Installation.

FUEL PRESSURE LEAK DOWN TEST

Use this test in conjunction with the Fuel Pump Pressure Test and Fuel Pump Capacity Test.

Check Valve Operation: The electric fuel pump outlet contains a one-way check valve to prevent fuel flow back into the tank and to maintain fuel supply line pressure (engine warm) when pump is not operational. It is also used to keep the fuel supply line full of gasoline when pump is not operational. After the vehicle has cooled down, fuel pressure may drop to 0 psi (cold fluid contracts), but liquid gasoline will remain in fuel supply line between the check valve and fuel injectors. **Fuel pressure that has dropped to 0 psi on a cooled down vehicle (engine off) is a normal condition.** When the electric fuel pump is activated, fuel pressure should **immediately** (1–2 seconds) rise to specification.

Abnormally long periods of cranking to restart a **hot** engine that has been shut down for a short period of time may be caused by:

- Fuel pressure bleeding past a fuel injector(s).
- Fuel pressure bleeding past the check valve in the fuel pump module.

(1) Disconnect the fuel inlet line at fuel rail. Refer to Fuel Tubes/Lines/Hoses and Clamps in this section of the group for procedures. On some engines, air cleaner housing removal may be necessary before fuel line disconnection.

(2) Connect the appropriate Fuel Line Pressure Test Adapter Tool (number 6539, 6631, 6541 or 6923) between the disconnected fuel line and fuel rail (Fig. 8) or (Fig. 9).

(3) Connect the 0-414 kPa (0-60 psi) fuel pressure test gauge (from Gauge Set 5069) to the test port on the appropriate Adaptor Tool. **The fittings on both tools must be in good condition and free from any small leaks before performing the proceeding test.**

(4) Start engine and bring to normal operating temperature.

(5) Observe test gauge. Normal operating pressure should be 339 kPa \pm 34 kPa (49.2 psi \pm 5 psi).

(6) Shut engine off.

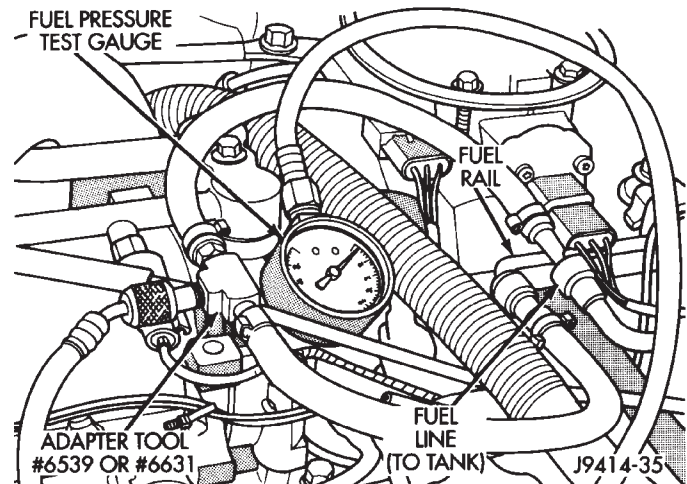
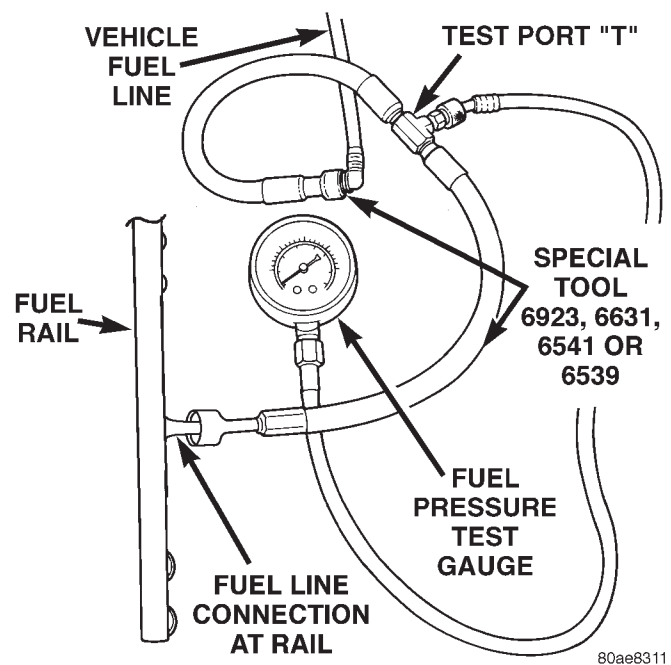


Fig. 8 Connecting Adapter Tool—Typical



80ae8311

Fig. 9 Connecting Adapter Tool—Typical

(7) Pressure should not fall below **30 psi for five minutes.**

(8) If pressure falls below 30 psi, it must be determined if a fuel injector, the check valve within the fuel pump module, or a fuel tube/line is leaking.

(9) Again, start engine and bring to normal operating temperature.

(10) Shut engine off.

(11) **Testing for fuel injector or fuel rail leakage:** Clamp off the rubber hose portion of Adaptor Tool between the fuel rail and the test port "T" on Adapter Tool. If pressure now holds at or above 30 psi, a fuel injector or the fuel rail is leaking.

(12) **Testing for fuel pump check valve, filter/regulator check valve or fuel tube/line leakage:**

DIAGNOSIS AND TESTING (Continued)

Clamp off the rubber hose portion of Adaptor Tool between the vehicle fuel line and test port "T" on Adapter Tool. If pressure now holds at or above 30 psi, a leak may be found at a fuel tube/line. If no leaks are found at fuel tubes or lines, one of the check valves in either the electric fuel pump or filter/regulator may be leaking.

Note: A quick loss of pressure usually indicates a defective check valve in the filter/regulator. A slow loss of pressure usually indicates a defective check valve in the electric fuel pump.

The electric fuel pump is not serviced separately. Replace the fuel pump module assembly. The filter/regulator may be replaced separately on certain applications. Refer to Fuel Filter/Fuel Pressure Regulator Removal/Installation for additional information.

FUEL PUMP AMPERAGE TEST

This amperage (current draw) test is to be done in conjunction with the Fuel Pump Pressure Test, Fuel Pump Capacity Test and Fuel Pressure Leak Down Test. Before performing the amperage test, be sure the temperature of the fuel tank is above 50° F (10° C).

The DRB Scan Tool along with the DRB Low Current Shunt (LCS) adapter (Fig. 10) and its test leads will be used to check fuel pump amperage specifications.

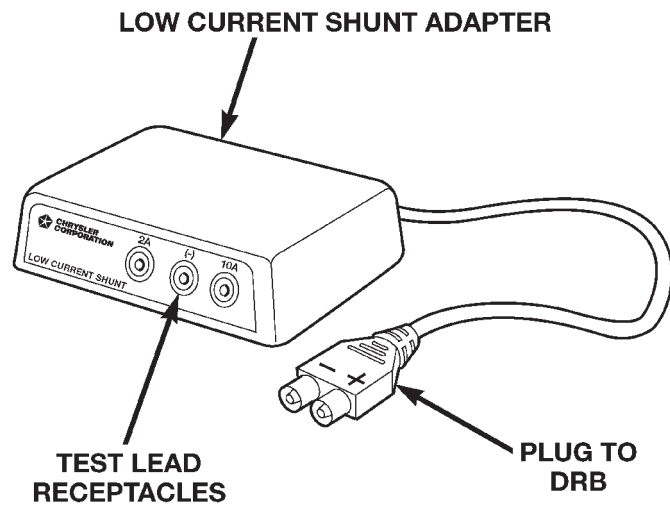


Fig. 10 Low Current Shunt Adapter

80add391

- (1) Obtain LCS adapter.
- (2) Plug cable from LCS adapter into DRB scan tool at SET 1 receptacle.
- (3) Plug DRB into vehicle 16-way connector (data link connector).
- (4) Connect (-) and (+) test cable leads into LCS adapter receptacles. Use **10 amp (10A +)** receptacle and common (-) receptacles.
- (5) Gain access to MAIN MENU on DRB screen.

- (6) Press DVOM button on DRB.
- (7) Using left/right arrow keys, highlight CHANNEL 1 function on DRB screen.
- (8) Press ENTER three times.
- (9) Using up/down arrow keys, highlight RANGE on DRB screen (screen will default to 2 amp scale).
- (10) Press ENTER to change 2 amp scale to 10 amp scale. **This step must be done to prevent damage to DRB scan tool or LCS adapter (blown fuse).**
- (11) Remove cover from Power Distribution Center (PDC).
- (12) Remove fuel pump relay from PDC. Refer to label on PDC cover for relay location.

WARNING: BEFORE PROCEEDING TO NEXT STEP, NOTE THE FUEL PUMP WILL BE ACTIVATED AND SYSTEM PRESSURE WILL BE PRESENT. THIS WILL OCCUR AFTER CONNECTING TEST LEADS FROM LCS ADAPTER INTO FUEL PUMP RELAY CAVITIES. THE FUEL PUMP WILL OPERATE EVEN WITH IGNITION KEY IN OFF POSITION. BEFORE ATTACHING TEST LEADS, BE SURE ALL FUEL LINES AND FUEL SYSTEM COMPONENTS ARE CONNECTED.

CAUTION: TO PREVENT POSSIBLE DAMAGE TO THE VEHICLE ELECTRICAL SYSTEM AND LCS ADAPTER, THE TEST LEADS MUST BE CONNECTED INTO RELAY CAVITIES EXACTLY AS SHOWN IN FOLLOWING STEPS.

Depending upon vehicle model, year or engine configuration, three different types of relays may be used: Type-1, type-2 and type-3.

(13) If equipped with **type-1 relay** (Fig. 11), attach test leads from LCS adapter into PDC relay cavities number 30 and 87. For location of these cavities, refer to numbers stamped to bottom of relay (Fig. 11).

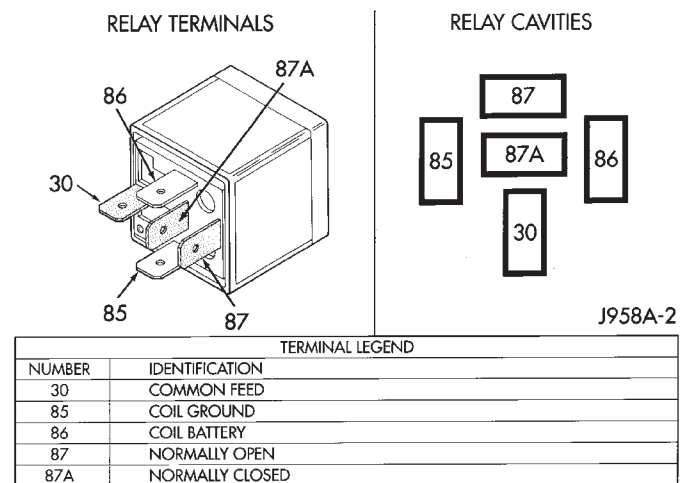


Fig. 11 Type-1 Relay

J958A-2

DIAGNOSIS AND TESTING (Continued)

(14) If equipped with **type-2 relay** (Fig. 12), attach test leads from LCS adapter into PDC relay cavities number 30 and 87. For location of these cavities, refer to numbers stamped to bottom of relay (Fig. 12).

(15) If equipped with **type-3 relay** (Fig. 13), attach test leads from LCS adapter into PDC relay cavities number 3 and 5. For location of these cavities, refer to numbers stamped to bottom of relay (Fig. 13).

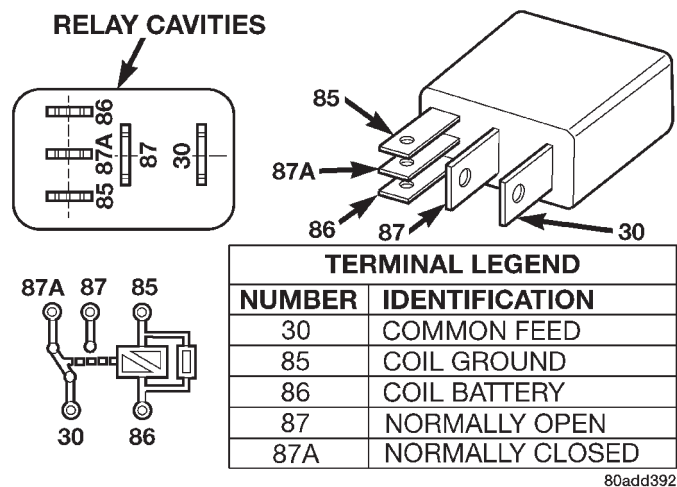


Fig. 12 Type-2 Relay

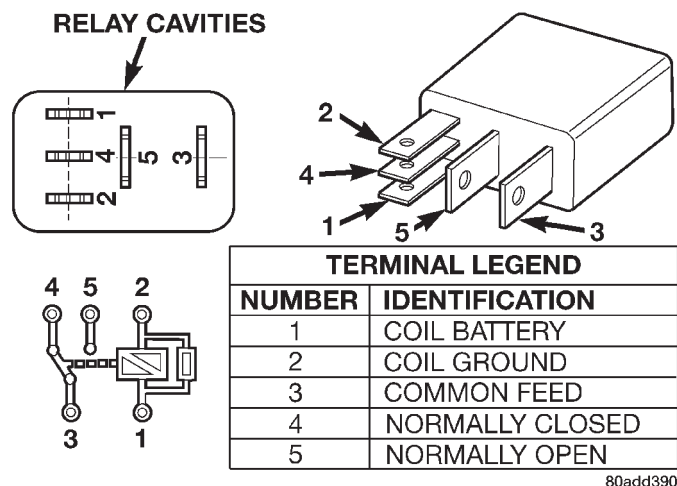


Fig. 13 Type-3 Relay

(16) When LCS adapter test leads are attached into relay cavities, fuel pump **will be activated**. Determine fuel pump amperage on DRB screen. Amperage should be below 10.0 amps. If amperage is below 10.0 amps, and specifications for the Fuel Pump Pressure, Fuel Pump Capacity and Fuel Pressure Leak Down tests were met, the fuel pump module is OK.

(17) If amperage is more than 10.0 amps, replace fuel pump module assembly. The electric fuel pump is not serviced separately.

(18) Disconnect test leads from relay cavities immediately after testing.

FUEL GAUGE SENDING UNIT

The fuel gauge sending unit contains a variable resistor (track). As the float moves up or down, electrical resistance will change. Refer to Group 8E, Instrument Panel and Gauges for Fuel Gauge testing. To test the gauge sending unit only, it must be removed from vehicle. The unit is part of the fuel pump module. Refer to Fuel Pump Module Removal/Installation for procedures. Measure the resistance across the sending unit terminals. With float in up position, resistance should be 20 ohms. With float in down position, resistance should be 220 ohms.

FUEL INJECTOR TEST

To perform a complete test of the fuel injectors and their circuitry, refer to DRB scan tool and appropriate Powertrain Diagnostics Procedures manual. To test the injector only, refer to the following:

Disconnect the fuel injector wire harness connector from the injector. Place an ohmmeter across the injector electrical terminals. Resistance reading should be approximately 12 ohms ± 1.2 ohms at 20°C (68°F).

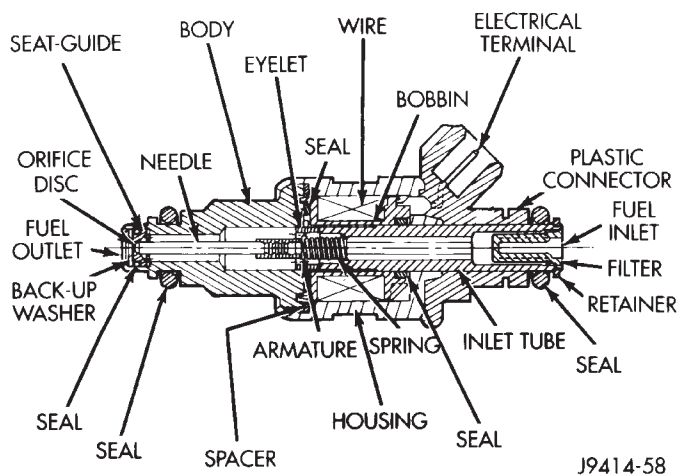


Fig. 14 Fuel Injector Internal Components—Typical SERVICE PROCEDURES

FUEL SYSTEM PRESSURE RELEASE PROCEDURE

Use the following procedure if the fuel rail is or is not equipped with a fuel pressure test port.

- (1) Remove the Fuel Pump relay from the Power Distribution Center (PDC). For location of the relay, refer to the label on the underside of the PDC cover.
- (2) Start and run engine until it stalls.
- (3) Attempt restarting engine until it will no longer run.

SERVICE PROCEDURES (Continued)

(4) Turn ignition key to OFF position.

CAUTION: Steps 1, 2, 3 and 4 must be performed to relieve high pressure fuel from within the fuel rail. Do not attempt to use the following steps to relieve this pressure as excessive fuel will be forced into a cylinder chamber.

(5) Unplug connector from any injector.

(6) Attach one end of a jumper wire with alligator clips (18 gauge or smaller) to either injector terminal.

(7) Connect the other end of the jumper wire to the positive side of the battery.

(8) Connect one end of a second jumper wire to the remaining injector terminal.

CAUTION: Powering an injector for more than a few seconds will permanently damage the injector.

(9) Momentarily touch the other end of this jumper wire to the negative terminal of the battery for no more than a few seconds.

(10) Place a rag or towel below the fuel line at the quick connect to the rail.

(11) Disconnect the quick connect fitting to the rail. Refer to Quick-Connect Fittings in this section.

(12) Return the fuel pump relay to the PDC.

(13) One or more Diagnostic Trouble Codes (DTC's) may have been stored in the PCM memory due to fuel pump relay removal. The DRB scan tool must be used to erase a DTC. Refer to Group 25, Emission Control System. See On-Board Diagnostics.

FUEL TUBES/LINES/HOSES AND CLAMPS

Also refer to the section on Quick-Connect Fittings.

WARNING: THE FUEL SYSTEM IS UNDER A CONSTANT PRESSURE (EVEN WITH THE ENGINE OFF). BEFORE SERVICING ANY FUEL SYSTEM HOSES, FITTINGS OR LINES, THE FUEL SYSTEM PRESSURE MUST BE RELEASED. REFER TO THE FUEL SYSTEM PRESSURE RELEASE PROCEDURE IN THIS GROUP.

Inspect all hose connections such as clamps, couplings and fittings to make sure they are secure and leaks are not present. The component should be replaced immediately if there is any evidence of degradation that could result in failure.

Never attempt to repair a plastic fuel line/tube. Replace as necessary.

Avoid contact of any fuel tubes/hoses with other vehicle components that could cause abrasions or scuffing. Be sure that the plastic fuel lines/tubes are properly routed to prevent pinching and to avoid heat sources.

The lines/tubes/hoses used on fuel injected vehicles are of a special construction. This is due to the higher fuel pressures and the possibility of contaminated fuel in this system. If it is necessary to replace these lines/tubes/hoses, only those marked EFM/EFI may be used.

If equipped: The hose clamps used to secure rubber hoses on fuel injected vehicles are of a special rolled edge construction. This construction is used to prevent the edge of the clamp from cutting into the hose. Only these rolled edge type clamps may be used in this system. All other types of clamps may cut into the hoses and cause high-pressure fuel leaks.

Use new original equipment type hose clamps. Tighten hose clamps to 3 N-m (25 in. lbs.) torque.

QUICK-CONNECT FITTINGS

Also refer to the Fuel Tubes/Lines/Hoses and Clamps section.

Different types of quick-connect fittings are used to attach various fuel system components. These are: a single-tab type, a two-tab type, a plastic retainer ring type or a latch clip type. Certain fittings may require the use of a special tool for disconnection.

SINGLE-TAB TYPE

This type of fitting is equipped with a single pull tab (Fig. 15). The tab is removable. After the tab is removed, the quick-connect fitting can be separated from the fuel system component.

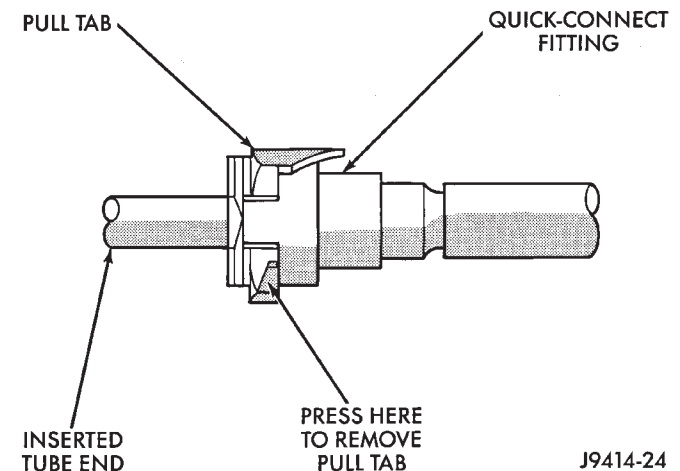


Fig. 15 Single-Tab Type Fitting

CAUTION: The interior components (o-rings, spacers) of this type of quick-connect fitting are not serviced separately, but new pull tabs are available. Do not attempt to repair damaged fittings or fuel lines/tubes. If repair is necessary, replace the complete fuel tube assembly.

SERVICE PROCEDURES (Continued)

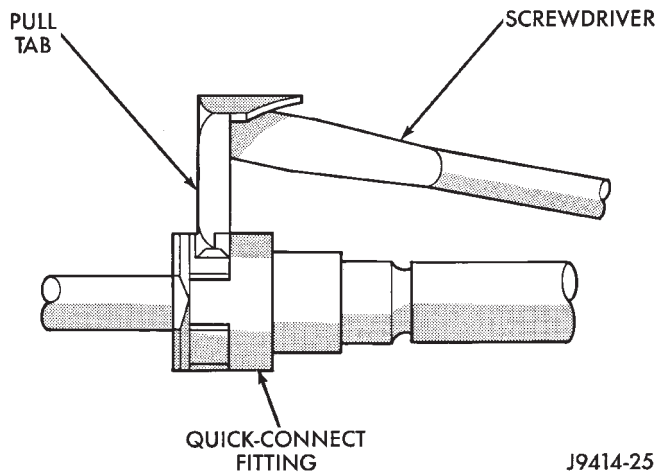
WARNING: THE FUEL SYSTEM IS UNDER A CONSTANT PRESSURE (EVEN WITH THE ENGINE OFF). BEFORE SERVICING ANY FUEL SYSTEM HOSES, FITTINGS OR LINES, THE FUEL SYSTEM PRESSURE MUST BE RELEASED. REFER TO THE FUEL SYSTEM PRESSURE RELEASE PROCEDURE IN THIS GROUP.

DISCONNECTION/CONNECTION

- (1) Perform fuel pressure release procedure. Refer to Fuel Pressure Release Procedure in this group.
- (2) Disconnect negative battery cable from battery.
- (3) Clean fitting of any foreign material before disassembly.
- (4) Press release tab on side of fitting to release pull tab (Fig. 16).

CAUTION: If this release tab is not pressed prior to releasing the pull tab, the pull tab will be damaged.

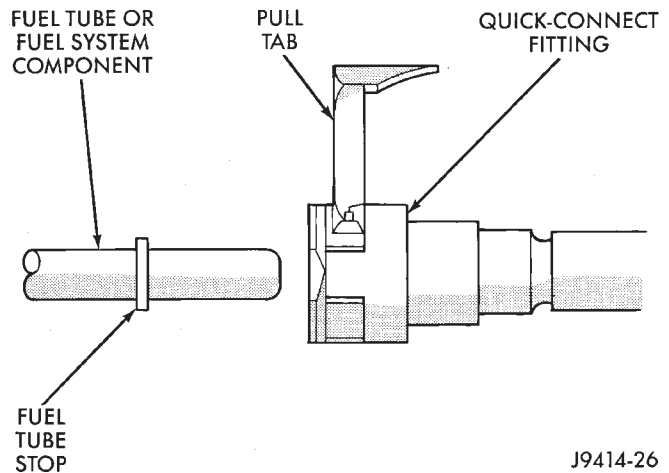
- (5) While pressing release tab on side of fitting, use a screwdriver to pry up pull tab (Fig. 16).



J9414-25

Fig. 16 Disconnecting Single-Tab Type Fitting

- (6) Raise pull tab until it separates from quick-connect fitting (Fig. 17). Discard old pull tab.
- (7) Disconnect quick-connect fitting from fuel system component being serviced.
- (8) Inspect quick-connect fitting body and fuel system component for damage. Replace as necessary.
- (9) Prior to connecting quick-connect fitting to component being serviced, check condition of fitting and component. Clean parts with a lint-free cloth. Lubricate with clean engine oil.
- (10) Insert quick-connect fitting into fuel tube or fuel system component until built-on stop on fuel tube or component rests against back of fitting.
- (11) Obtain a new pull tab. Push new tab down until it locks into place in quick-connect fitting.



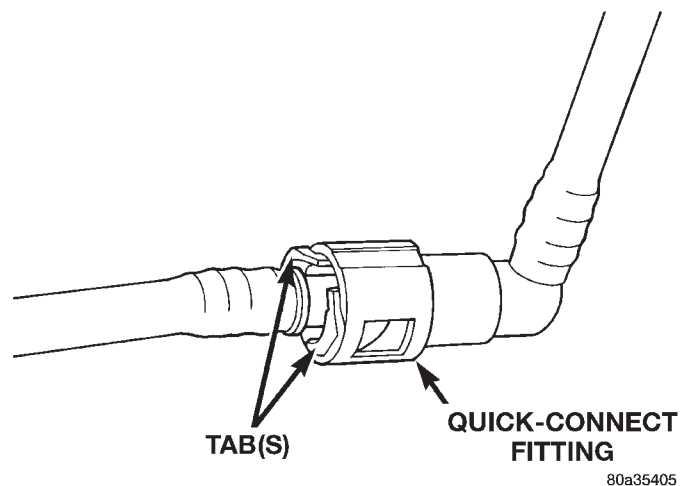
J9414-26

Fig. 17 Removing Pull Tab

- (12) Verify a locked condition by firmly pulling on fuel tube and fitting (15-30 lbs.).
- (13) Connect negative cable to battery.
- (14) Start engine and check for leaks.

TWO-TAB TYPE FITTING

This type of fitting is equipped with tabs located on both sides of the fitting (Fig. 18). These tabs are supplied for disconnecting the quick-connect fitting from component being serviced.



80a35405

Fig. 18 Typical Two-Tab Type Quick-Connect Fitting

CAUTION: The interior components (o-rings, spacers) of this type of quick-connect fitting are not serviced separately, but new plastic retainers are available. Do not attempt to repair damaged fittings or fuel lines/tubes. If repair is necessary, replace the complete fuel tube assembly.

SERVICE PROCEDURES (Continued)

WARNING: THE FUEL SYSTEM IS UNDER A CONSTANT PRESSURE (EVEN WITH THE ENGINE OFF). BEFORE SERVICING ANY FUEL SYSTEM HOSES, FITTINGS OR LINES, THE FUEL SYSTEM PRESSURE MUST BE RELEASED. REFER TO THE FUEL PRESSURE RELEASE PROCEDURE IN THIS GROUP.

DISCONNECTION/CONNECTION

- (1) Perform fuel pressure release procedure. Refer to Fuel Pressure Release Procedure in this group.
- (2) Disconnect negative battery cable from battery.
- (3) Clean fitting of any foreign material before disassembly.
- (4) To disconnect quick-connect fitting, squeeze plastic retainer tabs (Fig. 18) against sides of quick-connect fitting with your fingers. Tool use is not required for removal and may damage plastic retainer. Pull fitting from fuel system component being serviced. The plastic retainer will remain on component being serviced after fitting is disconnected. The o-rings and spacer will remain in quick-connect fitting connector body.
- (5) Inspect quick-connect fitting body and component for damage. Replace as necessary.

CAUTION: When the quick-connect fitting was disconnected, the plastic retainer will remain on the component being serviced. If this retainer must be removed, very carefully release the retainer from the component with two small screwdrivers. After removal, inspect the retainer for cracks or any damage.

- (6) Prior to connecting quick-connect fitting to component being serviced, check condition of fitting and component. Clean parts with a lint-free cloth. Lubricate with clean engine oil.
- (7) Insert quick-connect fitting to component being serviced and into plastic retainer. When a connection is made, a click will be heard.
- (8) Verify a locked condition by firmly pulling on fuel tube and fitting (15-30 lbs.).
- (9) Connect negative cable to battery.
- (10) Start engine and check for leaks.

PLASTIC RETAINER RING TYPE FITTING

This type of fitting can be identified by the use of a full-round plastic retainer ring (Fig. 19) usually black in color.

CAUTION: The interior components (o-rings, spacers, retainers) of this type of quick-connect fitting are not serviced separately. Do not attempt to repair damaged fittings or fuel lines/tubes. If repair is necessary, replace the complete fuel tube assembly.

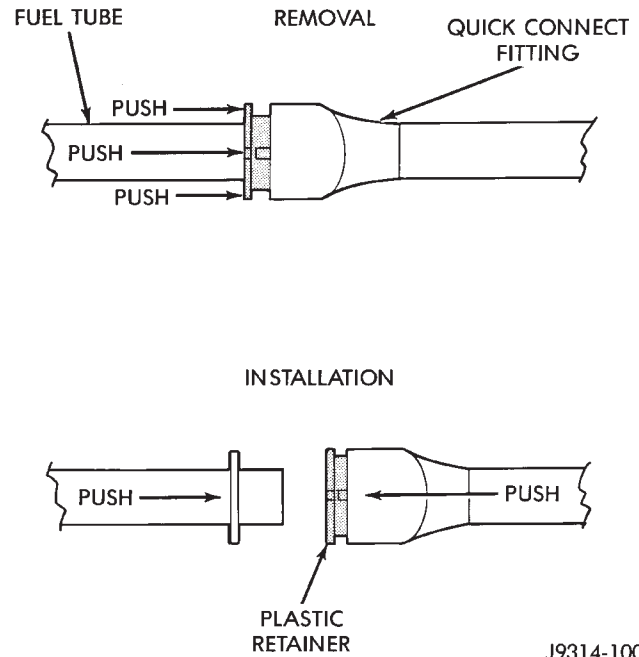


Fig. 19 Plastic Retainer Ring Type Fitting

WARNING: THE FUEL SYSTEM IS UNDER A CONSTANT PRESSURE (EVEN WITH THE ENGINE OFF). BEFORE SERVICING ANY FUEL SYSTEM HOSES, FITTINGS OR LINES, THE FUEL SYSTEM PRESSURE MUST BE RELEASED. REFER TO THE FUEL SYSTEM PRESSURE RELEASE PROCEDURE IN THIS GROUP.

DISCONNECTION/CONNECTION

- (1) Perform fuel pressure release procedure. Refer to Fuel Pressure Release Procedure in this section.
- (2) Disconnect negative battery cable from battery.
- (3) Clean fitting of any foreign material before disassembly.
- (4) To release fuel system component from quick-connect fitting, firmly push fitting towards component being serviced while firmly pushing plastic retainer ring into fitting (Fig. 19). With plastic ring depressed, pull fitting from component. **The plastic retainer ring must be pressed squarely into fitting body. If this retainer is cocked during removal, it may be difficult to disconnect fitting. Use an open-end wrench on shoulder of plastic retainer ring to aid in disconnection.**
- (5) After disconnection, plastic retainer ring will remain with quick-connect fitting connector body.
- (6) Inspect fitting connector body, plastic retainer ring and fuel system component for damage. Replace as necessary.
- (7) Prior to connecting quick-connect fitting to component being serviced, check condition of fitting

SERVICE PROCEDURES (Continued)

and component. Clean parts with a lint-free cloth. Lubricate with clean engine oil.

(8) Insert quick-connect fitting into component being serviced until a click is felt.

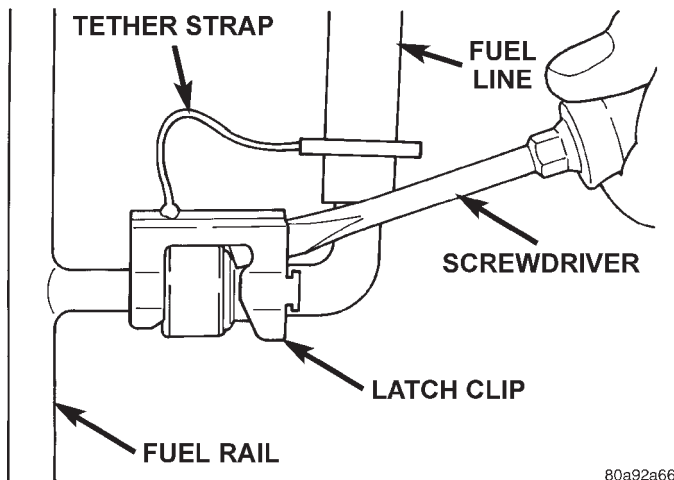
(9) Verify a locked condition by firmly pulling on fuel tube and fitting (15-30 lbs.).

(10) Connect negative battery cable to battery.

(11) Start engine and check for leaks.

LATCH CLIP FITTING (FUEL LINE-TO-FUEL RAIL)

A tethered latch clip (Fig. 20) is used to secure the fuel line to the fuel rail. A special tool will be necessary to separate fuel line from fuel rail after latch clip is removed. This same latch clip may also be used to secure other different fuel system components.



80a92a66

Fig. 20 Latch Clip Removal

CAUTION: The interior components (o-rings, spacers, retainers) of this type of quick-connect fitting are not serviced separately. Do not attempt to repair damaged fittings or fuel lines/tubes. If repair is necessary, replace the complete fuel tube assembly.

WARNING: THE FUEL SYSTEM IS UNDER A CONSTANT PRESSURE (EVEN WITH THE ENGINE OFF). BEFORE SERVICING ANY FUEL SYSTEM HOSES, FITTINGS OR LINES, THE FUEL SYSTEM PRESSURE MUST BE RELEASED. REFER TO THE FUEL SYSTEM PRESSURE RELEASE PROCEDURE IN THIS GROUP.

DISCONNECTION/CONNECTION

(1) Perform fuel pressure release procedure. Refer to Fuel Pressure Release Procedure in this group.

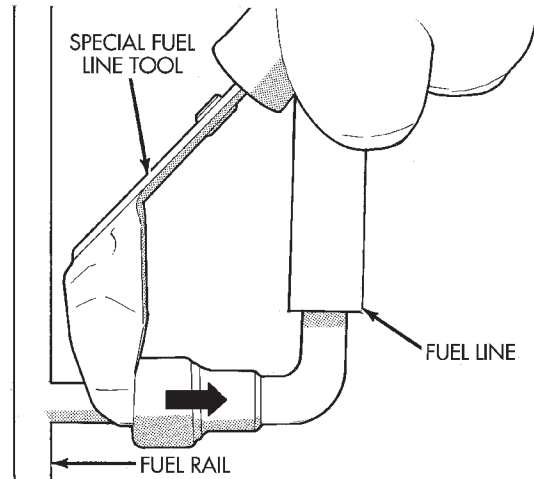
(2) Disconnect negative battery cable from battery.

(3) Clean fitting of any foreign material before disassembly.

(4) Pry up on latch clip with a screwdriver (Fig. 20).

(5) Slide latch clip toward fuel rail while lifting with screwdriver.

(6) Insert special fuel line removal tool (Snap-On number FIH 9055-1 or equivalent) into fuel line (Fig. 21). Use this tool to release locking fingers in end of line.



J9514-6

Fig. 21 Fuel Line Disconnection

(7) With special tool still inserted, pull fuel line from fuel rail.

(8) After disconnection, locking fingers will remain within quick-connect fitting at end of fuel line.

(9) Prior to connecting fuel line to fuel rail, check condition of both fittings. Clean parts with a lint-free cloth. Lubricate with clean engine oil.

(10) Insert fuel line onto fuel rail until a click is felt.

(11) Install latch clip (snaps into position). **If latch clip will not fit, this indicates fuel line is not properly installed to fuel rail. Recheck fuel line connection.**

(12) Verify a locked condition by firmly pulling on fuel line and fitting (15-30 lbs.).

(13) Connect negative battery cable to battery.

(14) Start engine and check for leaks.

REMOVAL AND INSTALLATION

FUEL FILTER/FUEL PRESSURE REGULATOR

The combination Fuel Filter/Fuel Pressure Regulator is located on the fuel pump module. The fuel pump module is located on top of fuel tank.

The filter/regulator may be removed without removing fuel pump module although fuel tank must be removed.

REMOVAL AND INSTALLATION (Continued)

REMOVAL

(1) Remove fuel tank. Refer to Fuel Tank Removal/Installation.

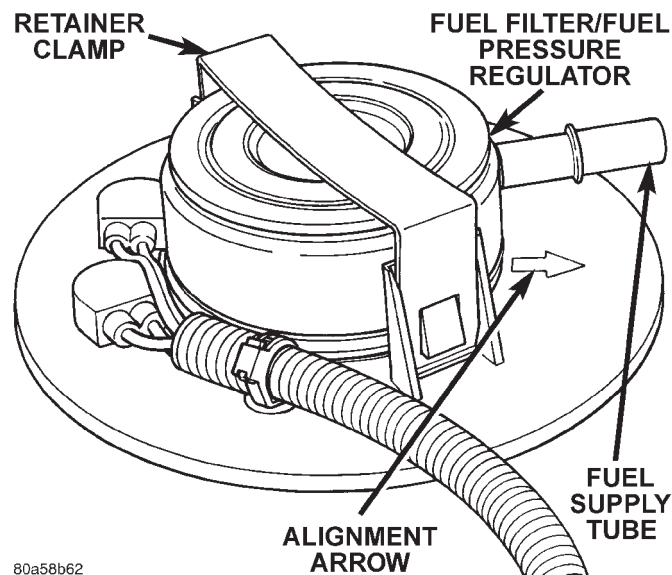
(2) Clean area around filter/regulator.

(3) Remove retainer clamp from top of filter/regulator (Fig. 22). Clamp snaps to tabs on pump module. Discard old clamp.

(4) Pry filter/regulator from top of pump module with 2 screwdrivers. Unit is snapped into module.

(5) Discard gasket below filter/regulator (Fig. 23).

(6) Before discarding filter/regulator assembly, inspect assembly to verify that o-rings (Fig. 24) are intact. If the smallest of the two o-rings can not be found on bottom of filter/regulator, it may be necessary to remove it from the fuel inlet passage in fuel pump module.



80a58b62

Fig. 22 Fuel Filter/Fuel Pressure Regulator

INSTALLATION

(1) Clean recessed area in pump module where filter/regulator is to be installed.

(2) Obtain new filter/regulator (two new o-rings should already be installed).

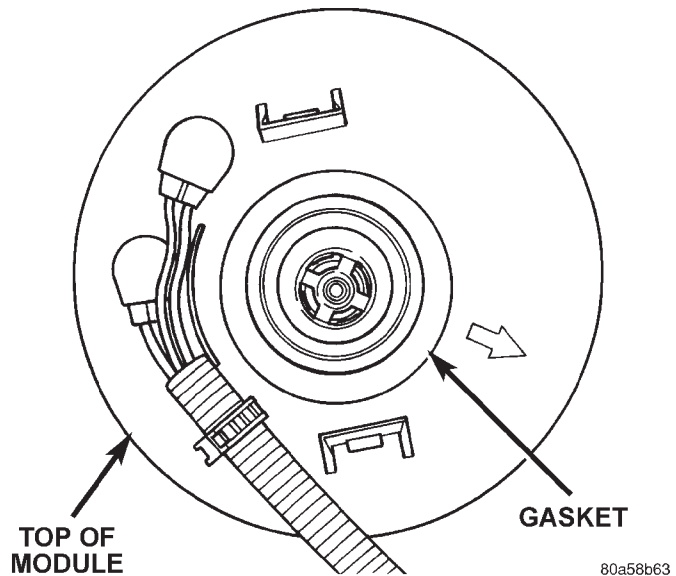
(3) Apply a small amount of clean engine oil to o-rings. **Do not install o-rings separately into fuel pump module. They will be damaged when installing filter/regulator.**

(4) Install new gasket to top of fuel pump module.

(5) Press new filter/regulator into top of pump module until it snaps into position (a positive click must be heard or felt).

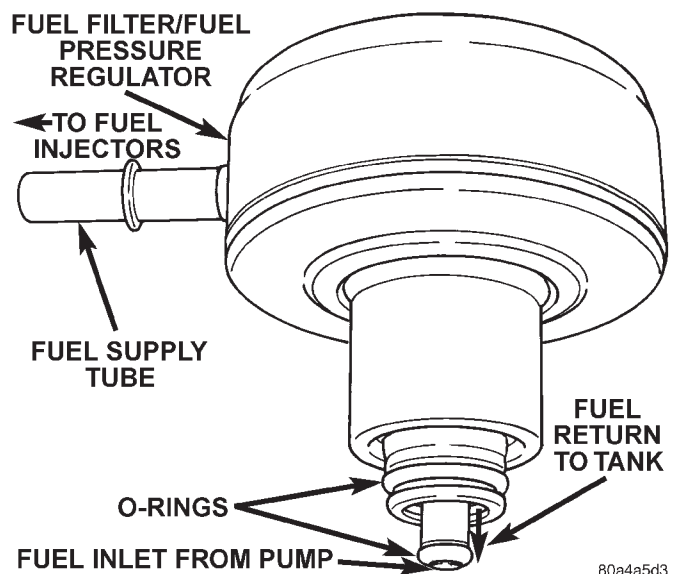
(6) The molded arrow (Fig. 22) on top of fuel pump module should be pointed towards front of vehicle (12 o'clock position).

(7) Rotate filter/regulator until fuel supply tube (fitting) is pointed to 11 o'clock position.



80a58b63

Fig. 23 Fuel Filter/Fuel Pressure Regulator Gasket



80a4a5d3

Fig. 24 Fuel Filter/Fuel Pressure Regulator O-Rings

(8) Install new retainer clamp (clamp snaps over top of filter/regulator and locks to flanges on pump module).

(9) Install fuel tank. Refer to Fuel Tank Removal/Installation.

FUEL PUMP MODULE

Fuel tank removal will be necessary for fuel pump module removal.

REMOVAL

WARNING: THE FUEL SYSTEM IS UNDER A CONSTANT PRESSURE (EVEN WITH THE ENGINE OFF). BEFORE SERVICING THE FUEL PUMP MODULE, THE FUEL SYSTEM PRESSURE MUST BE RELEASED.

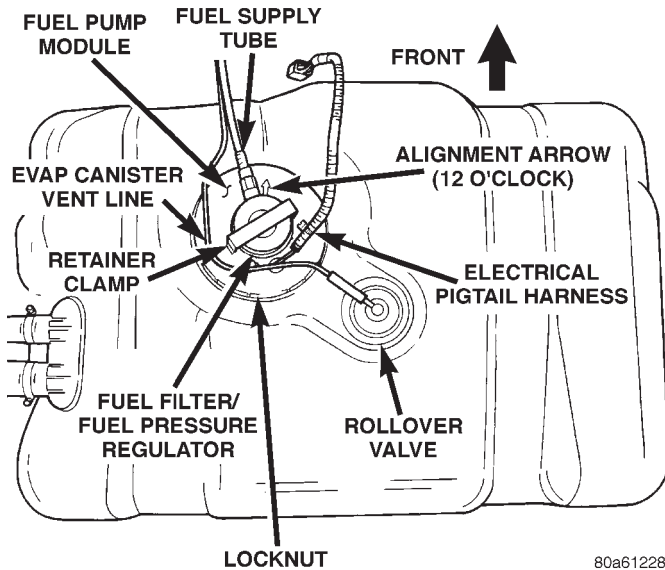
REMOVAL AND INSTALLATION (Continued)

(1) Drain fuel tank and remove tank. Refer to the Fuel Tank Removal/Installation section of this group.

(2) Thoroughly wash and clean area around pump module to prevent contaminants from entering tank.

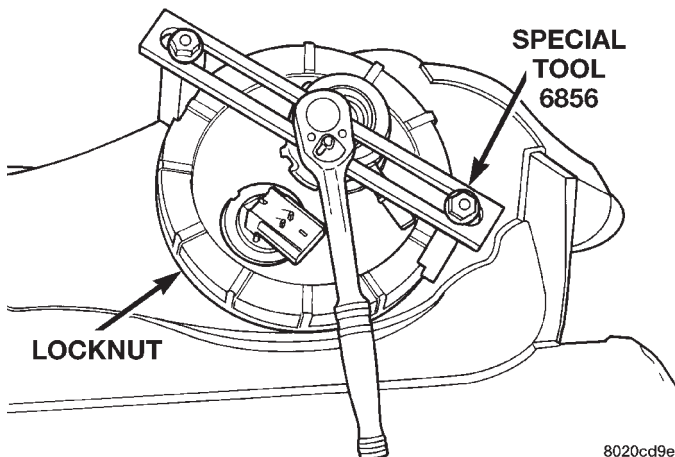
(3) The plastic fuel pump module locknut is threaded onto fuel tank (Fig. 25). Install Special Tool 6856 to fuel pump module locknut and remove locknut (Fig. 26). The fuel pump module will spring up when locknut is removed.

(4) Remove module from fuel tank.



80a61228

Fig. 25 Top View of Fuel Tank and Fuel Pump Module



8020cd9e

Fig. 26 Locknut Removal/Installation—Typical INSTALLATION

CAUTION: Whenever the fuel pump module is serviced, the module gasket must be replaced.

(1) Using a new gasket, position fuel pump module into opening in fuel tank.

(2) Position locknut over top of fuel pump module.

(3) Rotate module until arrow (Fig. 22) is pointed toward front of vehicle (12 o'clock position). This step must be done to prevent float/float rod assembly from contacting sides of fuel tank.

(4) Install Special Tool 6856 to locknut.

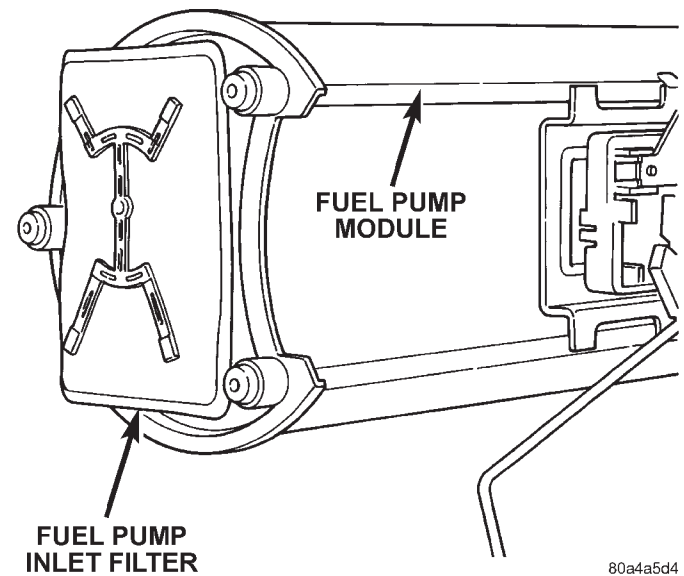
(5) Tighten locknut to 62 N·m (45 ft. lbs.) torque.

(6) Rotate fuel filter/fuel pressure regulator until its fitting is pointed to 11 o'clock position.

(7) Install fuel tank. Refer to Fuel Tank Installation in this section.

FUEL PUMP INLET FILTER

The fuel pump inlet filter (strainer) is located on the bottom of fuel pump module (Fig. 27). The fuel pump module is located on top of fuel tank.



80a4a5d4

Fig. 27 Fuel Pump Inlet Filter

REMOVAL

(1) Remove fuel tank. Refer to Fuel Tank Removal/Installation.

(2) Remove fuel pump module. Refer to Fuel Pump Module Removal/Installation.

(3) Remove filter by prying from bottom of module with 2 screwdrivers. Filter is snapped to module.

(4) Clean bottom of pump module.

INSTALLATION

(1) Snap new filter to bottom of module.

(2) Install fuel pump module. Refer to Fuel Pump Module Removal/Installation.

(3) Install fuel tank. Refer to Fuel Tank Removal/Installation.

FUEL GAUGE SENDING UNIT

The fuel gauge sending unit (fuel level sensor) and float assembly is located on the side of fuel pump module (Fig. 28). The fuel pump module is located within the fuel tank.

REMOVAL AND INSTALLATION (Continued)

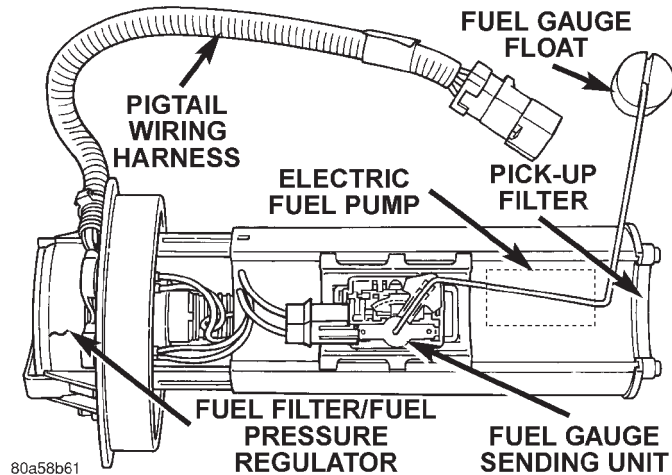


Fig. 28 Fuel Gauge Sending Unit Location

REMOVAL

- (1) Remove fuel tank. Refer to Fuel Tank Removal/Installation.
- (2) Remove fuel pump module. Refer to Fuel Pump Module Removal/Installation.
- (3) Remove electrical wire connector at sending unit terminals.
- (4) Press on release tab (Fig. 29) to remove sending unit from pump module.

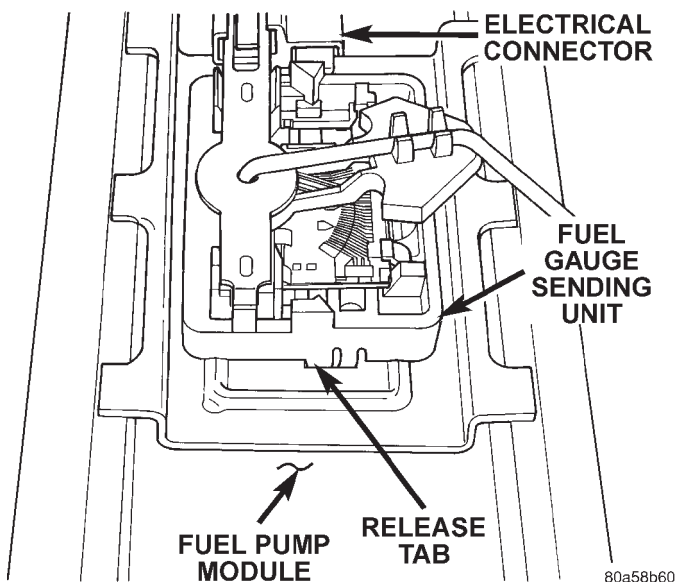


Fig. 29 Fuel Gauge Sending Unit Release Tab

INSTALLATION

- (1) Position sending unit to pump module and snap into place.
- (2) Connect electrical connector to terminals.
- (3) Install fuel pump module. Refer to Fuel Pump Module Removal/Installation.
- (4) Install fuel tank. Refer to Fuel Tank Removal/Installation.

FUEL INJECTOR RAIL—5.2L/5.9L ENGINES

WARNING: THE FUEL SYSTEM IS UNDER A CONSTANT PRESSURE (EVEN WITH THE ENGINE TURNED OFF). BEFORE SERVICING THE FUEL RAIL ASSEMBLY, THE FUEL SYSTEM PRESSURE MUST BE RELEASED.

To release fuel pressure, refer to the Fuel System Pressure Release Procedure found in this group.

CAUTION: The left and right fuel rails are replaced as an assembly. Do not attempt to separate the rail halves at the connecting hose (Fig. 30). Due to the design of this connecting hose, it does use any clamps. Never attempt to install a clamping device of any kind to the hose. When removing the fuel rail assembly for any reason, be careful not to bend or kink the connecting hose.

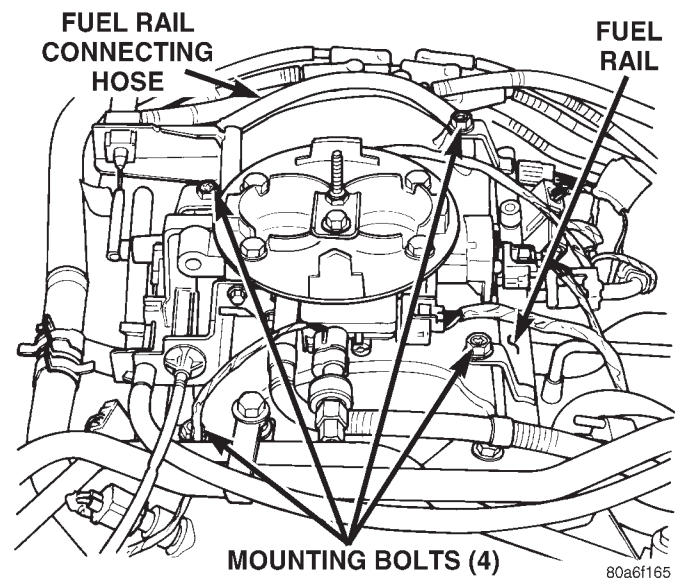


Fig. 30 Fuel Rail Assembly—Typical

REMOVAL

- (1) Remove negative battery cable at battery.
- (2) Remove air duct at throttle body.
- (3) Perform the fuel pressure release procedure.
- (4) Remove throttle body from intake manifold. Refer to Throttle Body removal in this group.
- (5) If equipped with air conditioning, remove the A-shaped A/C compressor-to-intake manifold support bracket (three bolts) (Fig. 31).
- (6) Disconnect electrical connectors at all fuel injectors (Fig. 32). The factory fuel injection wiring harness is numerically tagged (INJ 1, INJ 2, etc.) for injector position identification.
- (7) Disconnect fuel tube (line) at side of fuel rail. Refer to Quick-Connect Fittings for procedures.
- (8) Remove the remaining fuel rail mounting bolts.

REMOVAL AND INSTALLATION (Continued)

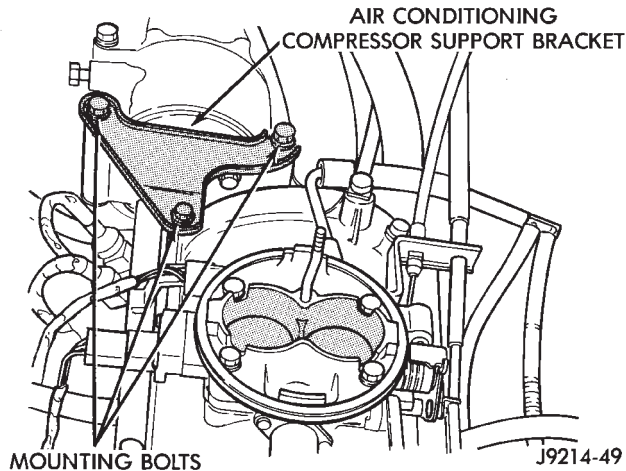


Fig. 31 A/C Compressor Support Bracket—Typical

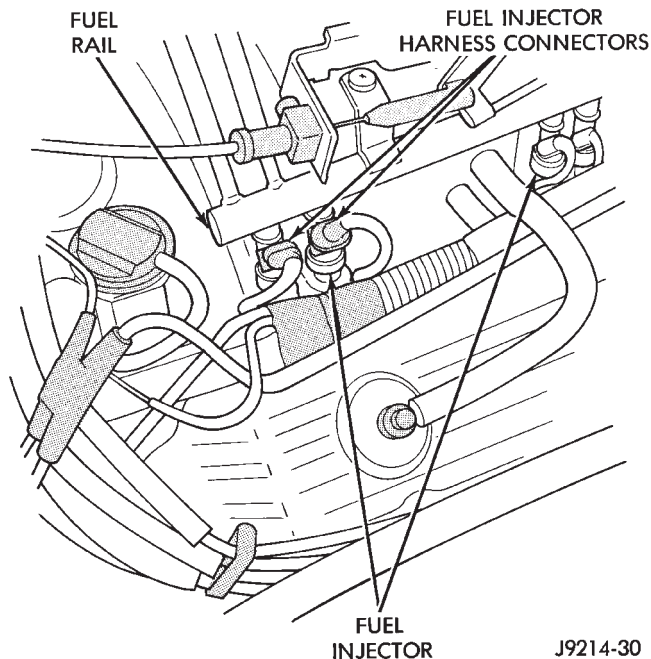


Fig. 32 Fuel Injector Connectors—Typical

(9) Gently rock and pull the **left** fuel rail until the fuel injectors just start to clear the intake manifold. Gently rock and pull the **right** fuel rail until the fuel injectors just start to clear the intake manifold. Repeat this procedure (left/right) until all fuel injectors have cleared the intake manifold.

(10) Remove fuel rail (with injectors attached) from engine.

(11) Remove the clip(s) retaining the injector(s) to fuel rail (Fig. 33) or (Fig. 34).

INSTALLATION

(1) Apply a small amount of engine oil to each fuel injector o-ring. This will help in fuel rail installation.

(2) Install injector(s) and injector clip(s) to fuel rail.

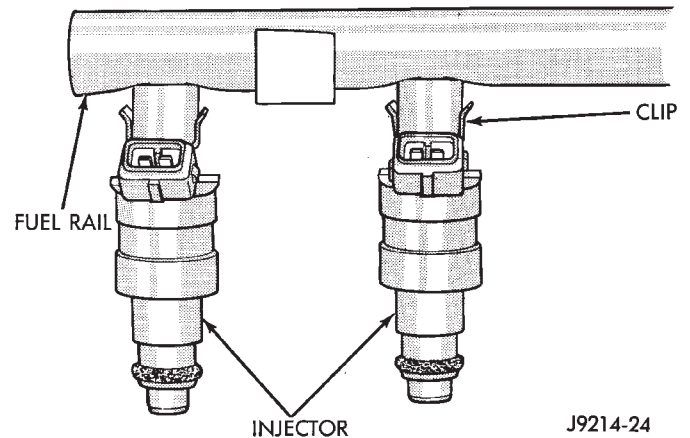


Fig. 33 Fuel Injector Mounting—Typical

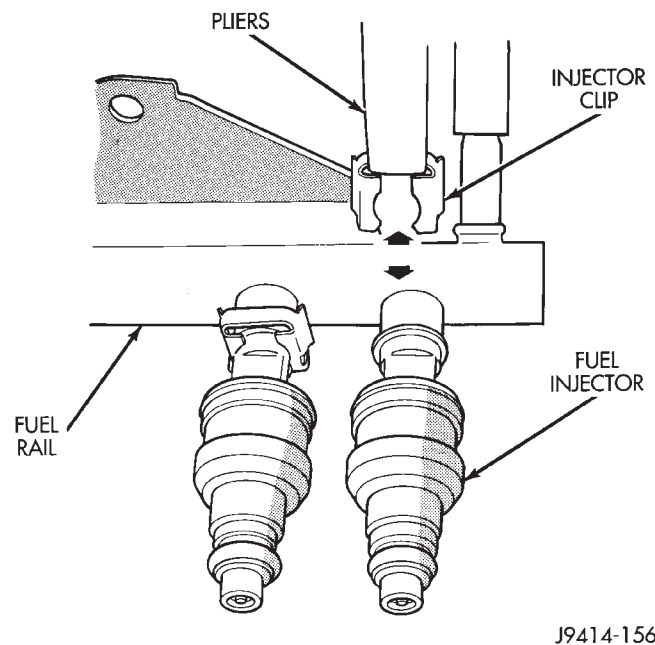


Fig. 34 Injector Retaining Clips—Typical Injector

(3) Position the fuel rail/fuel injector assembly to the injector openings on the intake manifold.

(4) Guide each injector into the intake manifold. Be careful not to tear the injector o-ring.

(5) Push the **right** fuel rail down until fuel injectors have bottomed on injector shoulder. Push the **left** fuel rail down until fuel injectors have bottomed on injector shoulder.

(6) Install fuel rail mounting bolts.

(7) Connect electrical connector to intake manifold air temperature sensor.

(8) Connect wiring to all fuel injectors. The injector wiring harness is numerically tagged.

(9) Install the A/C support bracket (if equipped).

(10) Install throttle body to intake manifold. Refer to Throttle Body installation in this section of the group.

REMOVAL AND INSTALLATION (Continued)

- (11) Install fuel tube (line) at side of fuel rail. Refer to Quick-Connect Fittings for procedures.
- (12) Install air duct to throttle body.
- (13) Connect battery cable to battery.
- (14) Start engine and check for leaks.

FUEL INJECTOR RAIL—4.0L ENGINE

REMOVAL

WARNING: THE FUEL SYSTEM IS UNDER CONSTANT FUEL PRESSURE EVEN WITH ENGINE OFF. THIS PRESSURE MUST BE RELEASED BEFORE SERVICING FUEL RAIL.

- (1) Remove fuel tank filler tube cap.
- (2) Perform Fuel System Pressure Release Procedure as described in this Group.
- (3) Disconnect negative battery cable from battery.
- (4) Remove air tube at top of throttle body. Note: Some engine/vehicles may require removal of air cleaner ducts at throttle body.
- (5) Remove injector harness electrical connectors at each injector. Each injector connector should have a numerical tag attached identifying its corresponding cylinder (Fig. 35). If not, identify each connector before removal.

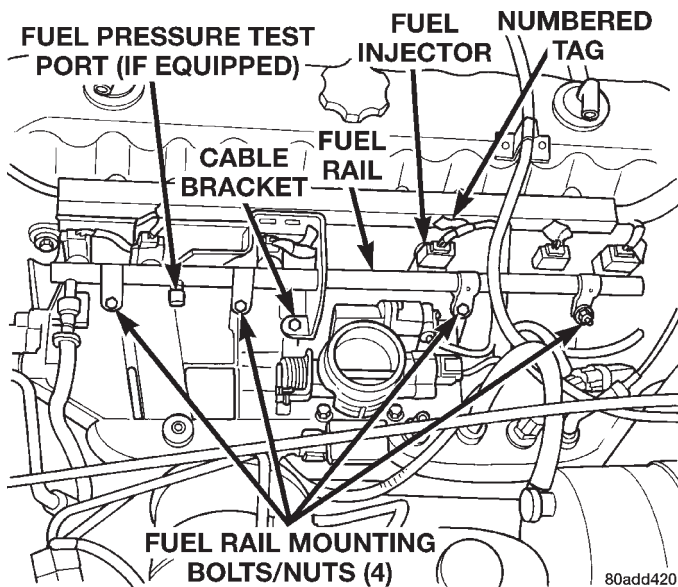


Fig. 35 Fuel Rail Mounting—4.0L Engine

- (6) Disconnect fuel supply line latch clip and fuel line at fuel rail. Refer to Quick-Connect Fittings in this group for procedures.
- (7) Disconnect throttle cable at throttle body. Refer to Throttle Cable Removal/Installation in this group for procedures.
- (8) Disconnect speed control cable at throttle body (if equipped). Refer to Speed Control Cable in Group 8H, Speed Control System for procedures.

- (9) Disconnect automatic transmission cable at throttle body (if equipped).
- (10) Remove cable routing bracket (Fig. 35) at intake manifold.
- (11) Clean dirt/debris from each fuel injector at intake manifold.
- (12) Remove fuel rail mounting nuts/bolts (Fig. 35).
- (13) Remove fuel rail by gently rocking until all the fuel injectors are out of intake manifold.

INSTALLATION

- (1) Clean each injector bore at intake manifold.
- (2) Apply a small amount of clean engine oil to each injector o-ring. This will aid in installation.
- (3) Position tips of all fuel injectors into the corresponding injector bore in intake manifold. Seat injectors into manifold.
- (4) Install and tighten fuel rail mounting bolts to 11 ± 3 N·m (100 ± 25 in. lbs.) torque.
- (5) Connect tagged injector harness connectors to appropriate injector.
- (6) Connect fuel line and fuel line latch clip to fuel rail. Refer Quick-Connect Fittings in this group for procedures.
- (7) Install protective cap to pressure test port fitting (if equipped).
- (8) Install cable routing bracket to intake manifold.
- (9) Connect throttle cable at throttle body.
- (10) Connect speed control cable at throttle body (if equipped).
- (11) Connect automatic transmission cable at throttle body (if equipped).
- (12) Install air tube (or duct) at top of throttle body.
- (13) Install fuel tank cap.
- (14) Connect negative battery cable to battery.
- (15) Start engine and check for fuel leaks.

FUEL INJECTOR(S)

WARNING: THE FUEL SYSTEM IS UNDER A CONSTANT PRESSURE EVEN WITH THE ENGINE TURNED OFF. BEFORE SERVICING THE FUEL INJECTOR(S), THE FUEL SYSTEM PRESSURE MUST BE RELEASED.

To release fuel pressure, refer to the Fuel System Pressure Release Procedure.

To remove one or more fuel injectors, the fuel rail assembly must be removed from engine.

REMOVAL

- (1) Remove air duct at throttle body.
- (2) Remove fuel injector rail assembly. Refer to Fuel Injector Rail removal in this section.

REMOVAL AND INSTALLATION (Continued)

- (3) Remove the clip(s) retaining the injector(s) to fuel rail (Fig. 33) or (Fig. 34).
- (4) Remove injector(s) from fuel rail.

INSTALLATION

- (1) Apply a small amount of engine oil to each fuel injector o-ring. This will help in fuel rail installation.
- (2) Install injector(s) and injector clip(s) to fuel rail.
- (3) Install fuel rail assembly. Refer to Fuel Injector Rail installation.
- (4) Install air duct at throttle body.
- (5) Start engine and check for leaks.

FUEL TANK

WARNING: THE FUEL SYSTEM IS UNDER CONSTANT FUEL PRESSURE EVEN WITH THE ENGINE OFF. THIS PRESSURE MUST BE RELEASED BEFORE SERVICING FUEL TANK.

Two different procedures may be used to drain fuel tank (lowering tank or using DRB scan tool).

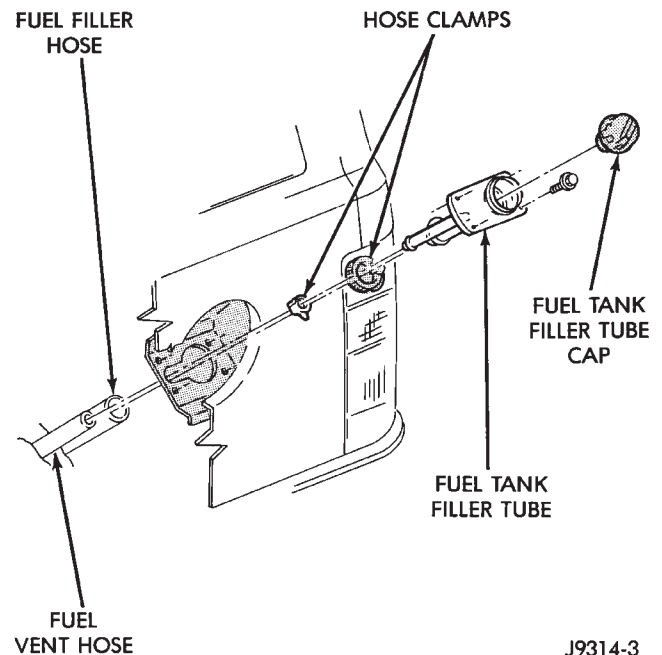
The quickest draining procedure involves lowering the fuel tank.

As an alternative procedure, the electric fuel pump may be activated allowing tank to be drained at fuel rail connection. Refer to DRB scan tool for fuel pump activation procedures. Before disconnecting fuel line at fuel rail, release fuel pressure. Refer to the Fuel System Pressure Release Procedure in this group for procedures. Attach end of special test hose tool number 6541, 6539, 6631 or 6923 at fuel rail disconnection (tool number will depend on model and/or engine application). Position opposite end of this hose tool to an approved gasoline draining station. Activate fuel pump and drain tank until empty.

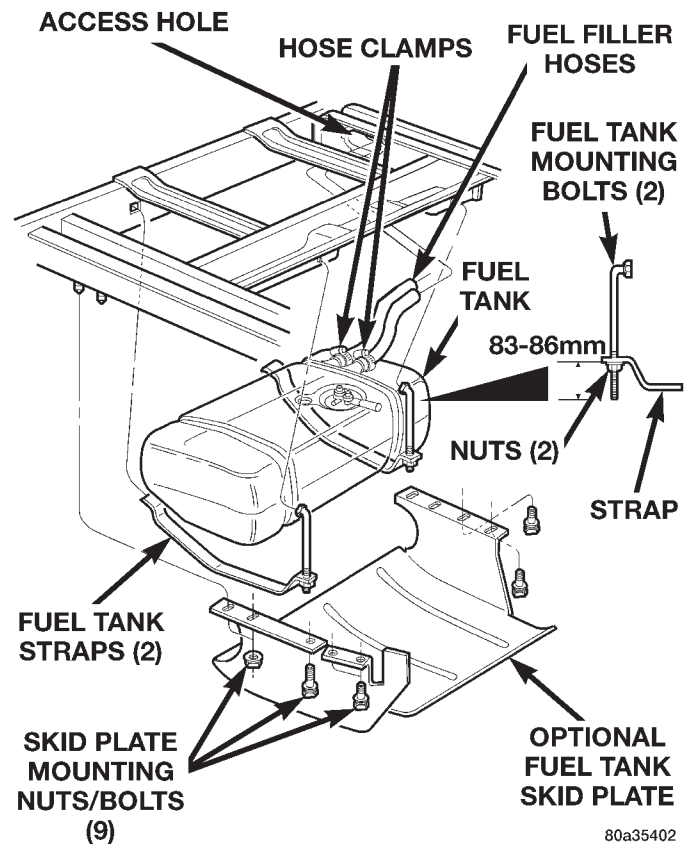
If electric fuel pump is not operating, tank must be lowered for fuel draining. Refer to following procedures.

REMOVAL

- (1) Disconnect negative battery cable at battery.
- (2) Release fuel system pressure. Refer to the Fuel System Pressure Release Procedure in this group.
- (3) Raise and support vehicle.
- (4) Remove fuel tank fill hose and vent hose clamps at fuel tank filler tube (Fig. 36). Remove both hoses at fuel filler tube (Fig. 36).
- (5) Remove rear tow hooks (if equipped).
- (6) Remove fuel tank skid plate mounting nuts/bolts and remove skid plate (Fig. 37) (if equipped).
- (7) Remove optional trailer hitch (if equipped).
- (8) Remove exhaust tailpipe heat shield mounting bolts and remove shield.



J9314-3

Fig. 36 Fuel Filler Tube and Hoses

80a35402

Fig. 37 Fuel Tank Mounting

REMOVAL AND INSTALLATION (Continued)

CAUTION: To protect fuel tank from exhaust heat, this shield must be reinstalled after tank installation.

- (9) Place a hydraulic jack to bottom of fuel tank.

WARNING: PLACE A SHOP TOWEL AROUND FUEL LINES TO CATCH ANY EXCESS FUEL.

(10) Disconnect fuel supply line near front of fuel tank (Fig. 38). Refer to Fuel Tubes/Lines/Hoses and Clamps in this group. Also refer to Quick-Connect Fittings for procedures.

(11) Disconnect EVAP canister vent line near front of tank (Fig. 38).

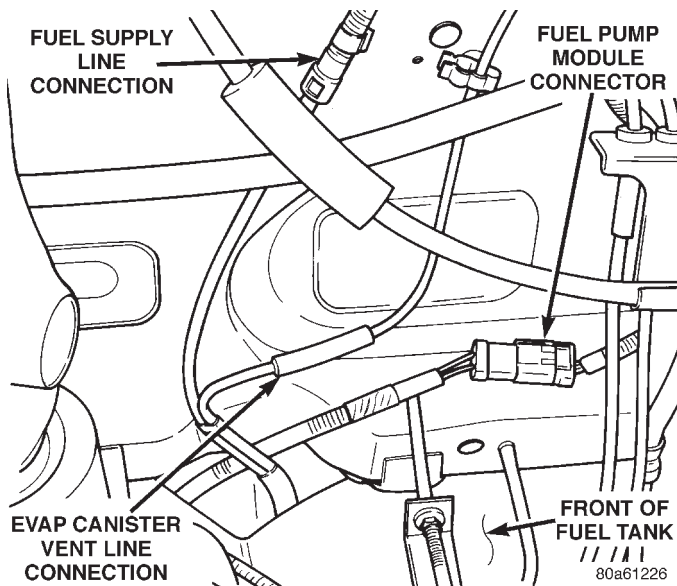


Fig. 38 Fuel Tank Connections at Front of Fuel Tank

(12) Disconnect fuel pump module electrical connector (pigtail harness) near front of tank (Fig. 38). Harness connector is clipped to body.

(13) Remove two fuel tank strap nuts (Fig. 37). Position both tank support straps away from tank.

(14) Carefully lower right side of tank while feeding both fuel hoses through access hole in body. **Fuel Tank Full And Not Drained Using DRB Scan Tool:** To prevent fuel loss through hoses, keep left side of tank higher than right side while lowering. Do not allow hose openings to drop lower than top of tank.

(15) Continue lowering tank until clear of vehicle. Place tank on floor with left side (hose side) higher than right side.

(16) Drain tank by removing fuel fill hose at tank. Fuel fill hose is largest of 2 hoses (Fig. 39). Insert the drain hose (from an approved gasoline draining station) into hose opening. Drain tank until empty.

(17) If fuel pump module removal is necessary, refer to Fuel Pump Module Removal/Installation in this group for procedures.

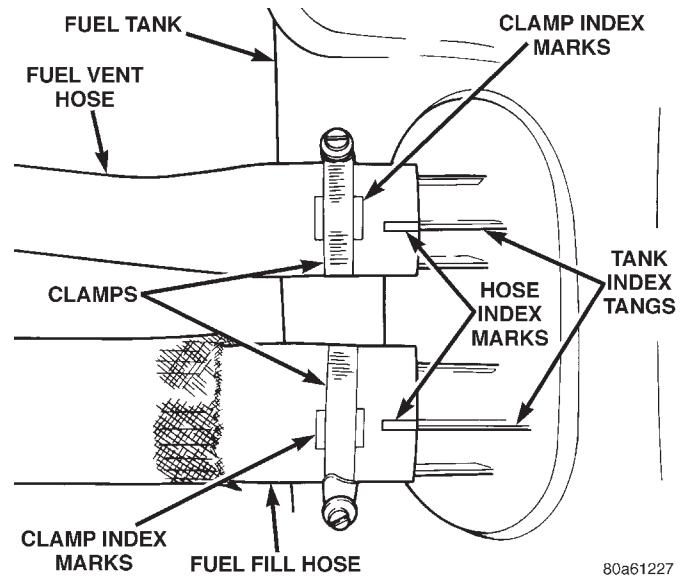


Fig. 39 Fuel Fill/Vent Hose Index Marks

INSTALLATION

(1) If fuel pump module is being installed, refer to Fuel Pump Module Removal/Installation in this group for procedures.

(2) Install fuel fill/vent hoses to tank fittings. To prevent hose from kinking, rotate each hose until index mark on hose is aligned to index tang on fuel tank (Fig. 39).

(3) Install hose clamps to hoses. Position clamps between index marks on each hose (Fig. 39).

(4) Position fuel tank to hydraulic jack.

(5) Raise tank into position while guiding fuel fill and vent hoses into and through access hole in body.

(6) Continue raising tank until positioned to body.

(7) Attach two fuel tank mounting straps and mounting nuts.

CAUTION: The two mounting nuts must be tightened until 83–86 mm (3.27 in.—3.39 in.) is attained between end of mounting bolt and bottom of strap. See insert (Fig. 37). Do not over tighten nuts.

(8) Install both fuel hoses to fuel fill tube. Tighten both retaining clamps.

(9) Connect fuel pump module pigtail harness electrical connector near front of tank.

(10) Connect fuel pump module supply line near front of tank. Refer to Fuel Tubes/Lines/Hoses and Clamps in this group. Also refer to Quick-Connect Fittings for procedures.

(11) Connect EVAP hose near front of tank.

(12) Install exhaust tailpipe heat shield.

(13) Install fuel tank skid plate and trailer hitch (if equipped).

(14) Install rear tow hooks (if equipped).

(15) Lower vehicle and connect battery cable to battery.

REMOVAL AND INSTALLATION (Continued)

FUEL TANK FILLER TUBE CAP

If replacement of the fuel tank filler tube cap is necessary, it must be replaced with an identical cap to be sure of correct system operation.

CAUTION: Remove the fuel tank filler tube cap to relieve fuel tank pressure. The cap must be removed prior to disconnecting any fuel system component or before draining the fuel tank.

ACCELERATOR PEDAL

The accelerator pedal is connected to the throttle body linkage by the throttle cable. The cable is protected by a plastic sheathing and is connected to the throttle body linkage by a ball socket. It is connected to the accelerator pedal arm by a plastic retainer (clip) (Fig. 40). This retainer (clip) snaps into the top of the accelerator pedal arm. Retainer tabs (built into the cable sheathing) fasten the cable to the dash panel.

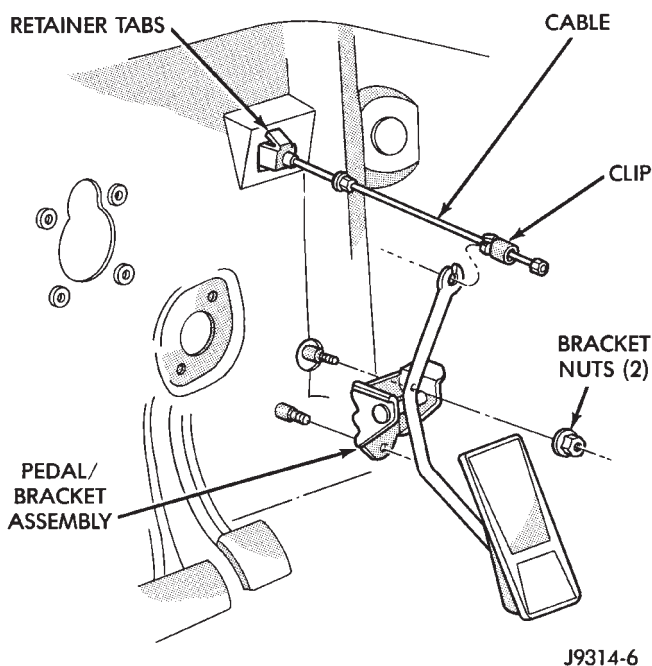


Fig. 40 Accelerator Pedal Mounting

Dual throttle return springs (attached to the throttle shaft) are used to close the throttle.

CAUTION: Never attempt to remove or alter these springs.

REMOVAL

CAUTION: Be careful not to damage or kink the cable core wire (within the cable sheathing) while servicing accelerator pedal or throttle cable.

(1) From inside the vehicle, hold up accelerator pedal. Remove plastic cable retainer (clip) and throttle cable core wire from upper end of pedal arm. Plastic cable retainer (clip) snaps into pedal arm.

(2) Remove accelerator pedal bracket nuts. Remove accelerator pedal assembly.

INSTALLATION

(1) Place accelerator pedal assembly over studs protruding from floor pan. Tighten mounting nuts to 8.5 N·m (75 in. lbs.) torque.

(2) Slide throttle cable into opening in top of pedal arm. Push plastic cable retainer (clip) into pedal arm opening until it snaps into place.

(3) Before starting engine, operate accelerator pedal to check for any binding.

THROTTLE CABLE

REMOVAL

(1) From inside the vehicle, hold up accelerator pedal. Remove plastic cable retainer (clip) and throttle cable core wire from upper end of pedal arm (Fig. 40). Plastic cable retainer (clip) snaps into pedal arm.

(2) Remove the cable core wire at pedal arm.

(3) From inside the vehicle, pinch both sides of the cable housing retainer tabs (Fig. 40) at the dash panel. Remove cable housing from dash panel and pull into the engine compartment.

(4) 4.0L Engine: Remove cable from clip on engine valve cover (Fig. 41)

(5) Remove the throttle cable ball end socket at throttle body linkage (Fig. 42) or (Fig. 43) (snaps off).

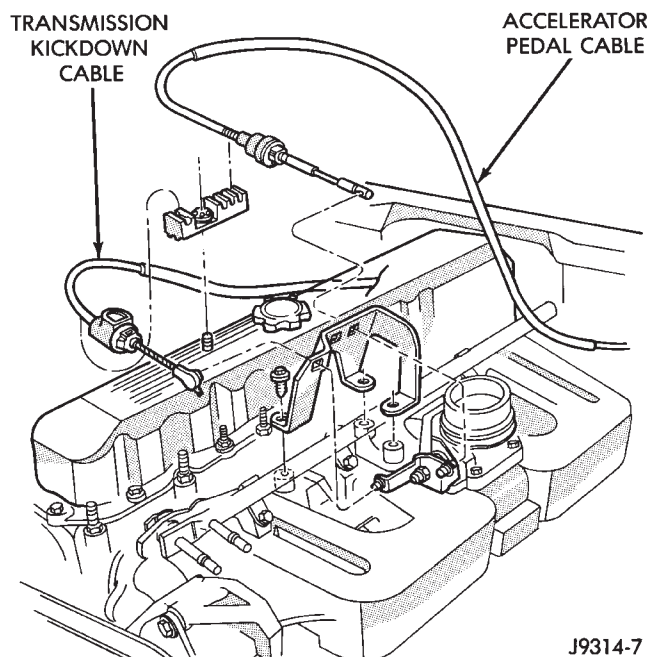


Fig. 41 Throttle Cable Routing—4.0L Engine

REMOVAL AND INSTALLATION (Continued)

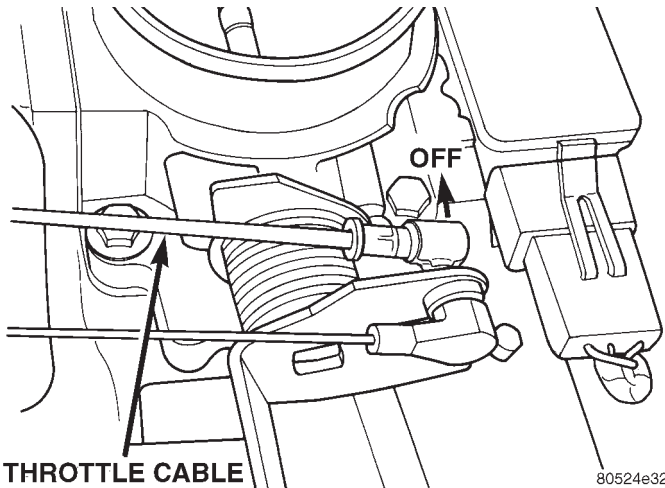


Fig. 42 Throttle Cable at Throttle Body—4.0L Engine

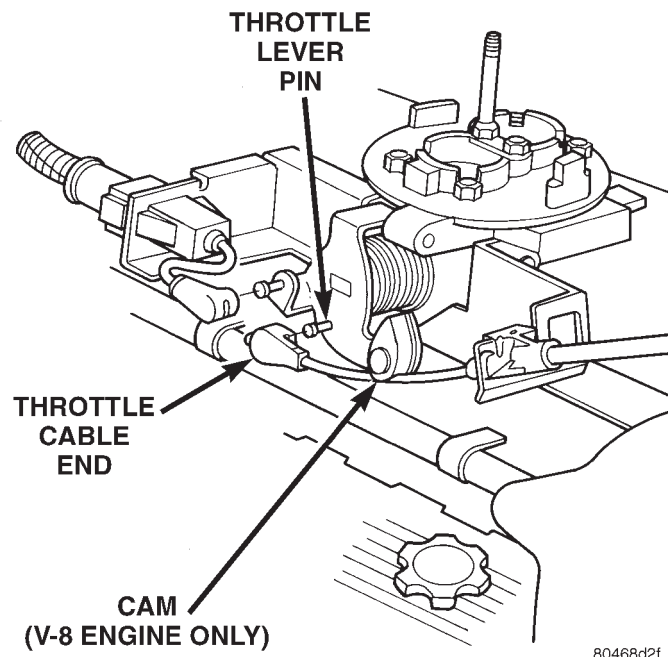


Fig. 43 Throttle Cable at Throttle Body—5.2L/5.9L V-8 Engines

(6) 4.0L Engine: Remove throttle cable from throttle body mounting bracket by compressing retainer tabs and pushing cable through hole in bracket. Remove throttle cable from vehicle.

(7) 5.2L/5.9L Engines: Remove cable housing at throttle body mounting bracket by pressing forward on release tab with a small screwdriver (Fig. 44). **To prevent cable housing breakage, press on the tab only enough to release the cable from the bracket.** Lift the cable housing straight up from bracket while pressing on release tab. Remove throttle cable from vehicle.

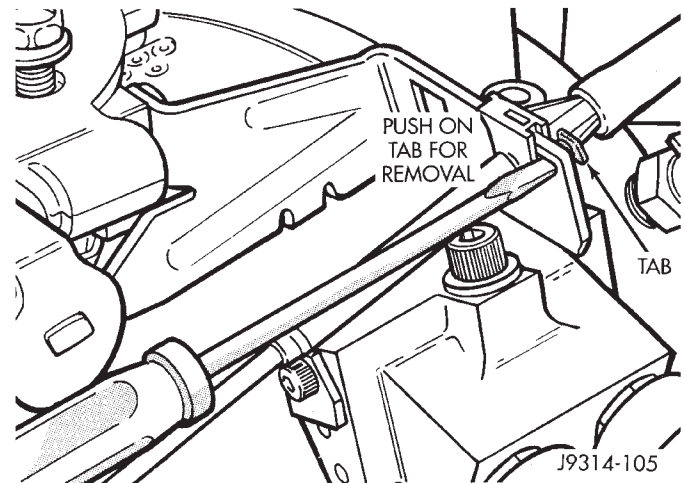


Fig. 44 Cable Release Tab—5.2L/5.9L Engines—Typical

INSTALLATION

(1) 4.0L Engine: Slide throttle cable through hole in throttle body bracket until retainer tabs lock into bracket. Connect cable ball end to throttle body linkage ball (snaps on).

(2) 5.2L/5.9L Engines: Connect cable ball end to throttle body linkage ball (snaps on). Connect cable to throttle body bracket (push down and lock).

(3) 4.0L Engine: Snap cable into clip on engine valve cover.

(4) Push other end of cable through opening in dash panel until retaining tabs lock into panel.

(5) From inside drivers compartment, slide throttle cable core wire into opening in top of pedal arm. Push cable retainer (clip) into pedal arm opening until it snaps in place.

(6) Before starting engine, operate accelerator pedal to check for any binding.

SPECIFICATIONS

VECI LABEL

If anything differs between the specifications found on the Vehicle Emission Control Information (VECI) label and the following specifications, use specifications on VECI label. The VECI label is located in the engine compartment.

FUEL TANK CAPACITY

Models	Liters	U.S. Gallons
All	87	23
Nominal refill capacities are shown. A variation may be observed from vehicle to vehicle due to manufacturing tolerance and refill procedure.		

FUEL SYSTEM PRESSURE

339 kPa ± 34 kPa (49.2 psi ± 5 psi).

TORQUE CHART

DESCRIPTION	TORQUE
Accelerator Pedal Bracket	
Mounting Nuts8.5 N·m (75 in. lbs.)
Fuel Pump Module Locknut62 N·m (45 ft. lbs.)
Fuel Rail Mounting Bolts—4.0L Engine11 N·m (100 in. lbs.)
Fuel Rail Mounting Bolts—	
5.2L/5.9L Engines23 N·m (200 in. lbs.)
Fuel Tank Mounting Nuts	Refer To Manual Text
Fuel Hose Clamps3 N·m (25 in. lbs.)

FUEL INJECTION SYSTEM

INDEX

	page		page
GENERAL INFORMATION			
INTRODUCTION	26	IDLE AIR CONTROL (IAC) MOTOR—5.2L/5.9L	
MODES OF OPERATION	26	ENGINES—PCM OUTPUT	38
DESCRIPTION AND OPERATION			
OXYGEN SENSOR (O ₂ S)—PCM INPUT	33	IGNITION CIRCUIT SENSE—PCM INPUT	33
AIR CONDITIONING (A/C) CLUTCH RELAY—		IGNITION COIL—4.0L ENGINES—PCM	
PCM OUTPUT	36	OUTPUT	39
AIR CONDITIONING (A/C) CONTROLS—PCM		IGNITION COIL—5.2L/5.9L ENGINES—PCM	
INPUT	30	OUTPUT	39
AUTO SHUTDOWN (ASD) RELAY—PCM		INTAKE MANIFOLD AIR TEMPERATURE	
OUTPUT	37	SENSOR—4.0L ENGINE—PCM INPUT	33
AUTOMATIC SHUTDOWN (ASD) RELAY		INTAKE MANIFOLD AIR TEMPERATURE	
SENSE—PCM INPUT	30	SENSOR—5.2L/5.9L ENGINES—PCM INPUT	33
BATTERY TEMPERATURE SENSOR—PCM		LEAK DETECTION PUMP (SWITCH) SENSE—	
INPUT	30	PCM INPUT	34
BATTERY VOLTAGE—PCM INPUT	30	LEAK DETECTION PUMP—PCM OUTPUT	39
BRAKE SWITCH—PCM INPUT	31	MALFUNCTION INDICATOR LAMP—PCM	
CAMSHAFT POSITION SENSOR—PCM INPUT	31	OUTPUT	39
CCD BUS (+/-) CIRCUITS-PCM OUTPUTS	37	MANIFOLD ABSOLUTE PRESSURE (MAP)	
CRANKSHAFT POSITION SENSOR—4.0L		SENSOR—4.0L ENGINE—PCM INPUT	34
ENGINE—PCM INPUT	31	MANIFOLD ABSOLUTE PRESSURE (MAP)	
CRANKSHAFT POSITION SENSOR—5.2L/5.9L		SENSOR—5.2L/5.9L ENGINES—PCM INPUT	34
ENGINES—PCM INPUT	31	OIL PRESSURE SENSOR—PCM INPUT	34
DATA LINK CONNECTOR—PCM INPUT AND		OUTPUT SHAFT SPEED SENSOR—PCM	
OUTPUT	37	INPUT	34
DUTY CYCLE EVAP PURGE SOLENOID		OVERDRIVE LAMP—PCM OUTPUT	39
VALVE-PCM OUTPUT	37	OVERDRIVE/OVERRIDE SWITCH-PCM INPUT	34
ENGINE COOLANT TEMPERATURE SENSOR—		POWER GROUND	35
4.0L ENGINE—PCM INPUT	32	POWERTRAIN CONTROL MODULE (PCM)	29
ENGINE COOLANT TEMPERATURE SENSOR—		SENSOR RETURN—PCM INPUT	35
5.2L/5.9L ENGINES—PCM INPUT	32	SIGNAL GROUND—PCM INPUT	35
FIVE VOLT SENSOR SUPPLY—PRIMARY	31	SPEED CONTROL SOLENOIDS—PCM OUTPUT	40
FIVE VOLT SENSOR SUPPLY—SECONDARY	31	SPEED CONTROL SWITCHES—PCM INPUT	35
FUEL INJECTORS—4.0L ENGINE—PCM		TACHOMETER—PCM OUTPUT	40
OUTPUT	38	THREE-FOUR SHIFT SOLENOID—PCM	
FUEL INJECTORS—5.2L/5.9L ENGINES—PCM		OUTPUT	40
OUTPUT	37	THROTTLE BODY—4.0L ENGINE	41
FUEL LEVEL SENSOR—PCM INPUT	31	THROTTLE BODY—5.2L/5.9L ENGINES	40
FUEL PUMP RELAY-PCM OUTPUT	38	THROTTLE POSITION SENSOR (TPS)—4.0L	
GENERATOR FIELD DRIVER (-)—PCM		ENGINE—PCM INPUT	35
OUTPUT	38	THROTTLE POSITION SENSOR (TPS)—5.2L/	
GENERATOR FIELD SOURCE (+)—PCM		5.9L ENGINES—PCM INPUT	35
OUTPUT	38	TORQUE CONVERTOR CLUTCH (TCC)	
GENERATOR LAMP—PCM OUTPUT	38	SOLENOID—PCM OUTPUT	40
GENERATOR OUTPUT—PCM INPUT	32	TRANSMISSION GOVERNOR PRESSURE	
GOVERNOR PRESSURE SOLENOID—PCM		SENSOR—PCM INPUT	35
OUTPUT	40	TRANSMISSION PARK/NEUTRAL SWITCH—	
IDLE AIR CONTROL (IAC) MOTOR—4.0L		PCM INPUT	35
ENGINE—PCM OUTPUT	38	TRANSMISSION RELAY—PCM OUTPUT	40
		TRANSMISSION TEMPERATURE SENSOR—	
		PCM INPUT	35

VEHICLE SPEED AND DISTANCE SENSOR— PCM INPUT	36	CAMSHAFT POSITION SENSOR	60
DIAGNOSIS AND TESTING		CRANKSHAFT POSITION SENSOR	60
ASD AND FUEL PUMP RELAYS	47	DUTY CYCLE EVAP CANISTER PURGE SOLENOID	59
CAMSHAFT AND CRANKSHAFT POSITION SENSORS	51	ENGINE COOLANT TEMPERATURE SENSOR— 4.0L ENGINE	63
ENGINE COOLANT TEMPERATURE SENSOR— 4.0L ENGINE	51	ENGINE COOLANT TEMPERATURE SENSOR— 5.2L/5.9L ENGINES	62
ENGINE COOLANT TEMPERATURE SENSOR— 5.2L/5.9L ENGINES	51	FUEL PUMP RELAY	55
IDLE AIR CONTROL (IAC) MOTOR—4.0L ENGINE .	52	IDLE AIR CONTROL (IAC) MOTOR—4.0L ENGINE	57
IDLE AIR CONTROL (IAC) MOTOR—5.2L/5.9L ENGINES	52	IDLE AIR CONTROL (IAC) MOTOR—5.2L/5.9L ENGINES	57
INTAKE MANIFOLD AIR TEMPERATURE SENSOR—4.0L ENGINE	52	INTAKE MANIFOLD AIR TEMPERATURE SENSOR—4.0L ENGINE	64
INTAKE MANIFOLD AIR TEMPERATURE SENSOR—5.2L/5.9L ENGINE	52	INTAKE MANIFOLD AIR TEMPERATURE SENSOR—5.2L/5.9L ENGINES	63
MANIFOLD ABSOLUTE PRESSURE (MAP) SENSOR TEST—4.0L ENGINE	49	MANIFOLD ABSOLUTE PRESSURE (MAP) SENSOR—4.0L ENGINE	58
MANIFOLD ABSOLUTE PRESSURE (MAP) SENSOR TEST—5.2L/5.9L ENGINES	48	MANIFOLD ABSOLUTE PRESSURE (MAP) SENSOR—5.2L/5.9L ENGINES	58
OXYGEN (O ₂ S) SENSORS—4.0L ENGINE	50	OXYGEN SENSOR—4.0L ENGINE	61
OXYGEN (O ₂ S) SENSORS—5.2L/5.9L ENGINES .	50	OXYGEN SENSOR—5.2L/5.9L ENGINES	60
THROTTLE BODY MINIMUM AIR FLOW CHECK PROCEDURE	53	POWERTRAIN CONTROL MODULE (PCM)	59
THROTTLE POSITION SENSOR (TPS)—4.0L ENGINE	53	THROTTLE BODY—4.0L ENGINE	56
THROTTLE POSITION SENSOR (TPS)—5.2L/ 5.9L ENGINES	53	THROTTLE BODY—5.2L/5.9L ENGINES	55
VEHICLE SPEED SENSOR	52	THROTTLE POSITION SENSOR (TPS)—4.0L ENGINE	57
VISUAL INSPECTION—4.0L ENGINE	44	THROTTLE POSITION SENSOR (TPS)—5.2L/ 5.9L ENGINES	56
VISUAL INSPECTION—5.2L/5.9L ENGINES	41	VEHICLE SPEED SENSOR	64
REMOVAL AND INSTALLATION		SPECIFICATIONS	
AIR CLEANER ELEMENT (FILTER)	62	TORQUE CHART	65
AIR CLEANER HOUSING	61	VECI LABEL	65
AUTOMATIC SHUTDOWN (ASD) RELAY	54	SPECIAL TOOLS	
		FUEL SYSTEM	66

GENERAL INFORMATION

INTRODUCTION

All engines are equipped with sequential Multi-Port Fuel Injection (MFI). The MFI system provides precise air/fuel ratios for all driving conditions.

The powertrain control module (PCM) (Fig. 1) operates the fuel system.

MODES OF OPERATION

As input signals to the powertrain control module (PCM) change, the PCM adjusts its response to the output devices. For example, the PCM must calculate different injector pulse width and ignition timing for idle than it does for wide open throttle (WOT).

The PCM will operate in two different modes: **Open Loop and Closed Loop.**

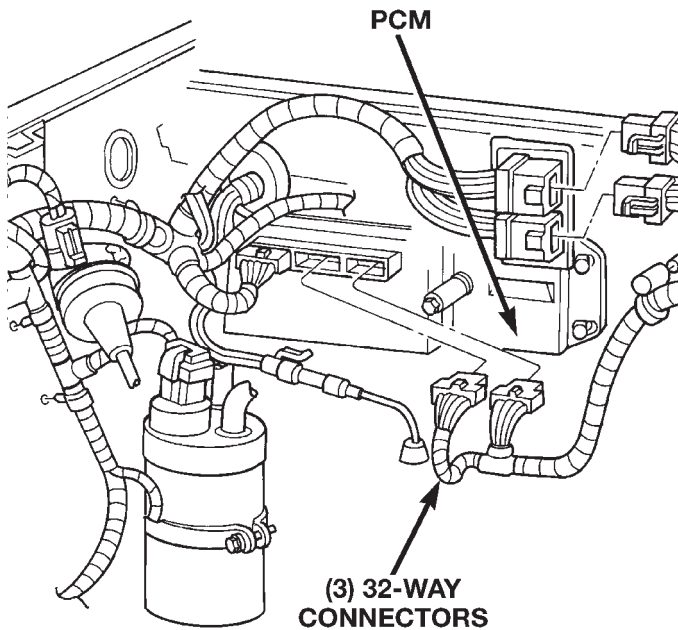
During Open Loop modes, the powertrain control module (PCM) receives input signals and responds

only according to preset PCM programming. Input from the oxygen (O₂S) sensors is not monitored during Open Loop modes.

During Closed Loop modes, the PCM will monitor the oxygen (O₂S) sensors input. This input indicates to the PCM whether or not the calculated injector pulse width results in the ideal air-fuel ratio. This ratio is 14.7 parts air-to-1 part fuel. By monitoring the exhaust oxygen content through the O₂S sensor, the PCM can fine tune the injector pulse width. This is done to achieve optimum fuel economy combined with low emission engine performance.

The fuel injection system has the following modes of operation:

- Ignition switch ON
- Engine start-up (crank)
- Engine warm-up
- Idle
- Cruise

GENERAL INFORMATION (Continued)

80a01300

Fig. 1 Powertrain Control Module (PCM)

- Acceleration
- Deceleration
- Wide open throttle (WOT)
- Ignition switch OFF

The ignition switch On, engine start-up (crank), engine warm-up, acceleration, deceleration and wide open throttle modes are Open Loop modes. The idle and cruise modes, (with the engine at operating temperature) are Closed Loop modes.

IGNITION SWITCH (KEY-ON) MODE

This is an Open Loop mode. When the fuel system is activated by the ignition switch, the following actions occur:

- The powertrain control module (PCM) pre-positions the idle air control (IAC) motor.
- The PCM determines atmospheric air pressure from the MAP sensor input to determine basic fuel strategy.
- The PCM monitors the engine coolant temperature sensor input. The PCM modifies fuel strategy based on this input.
- Intake manifold air temperature sensor input is monitored.
- Throttle position sensor (TPS) is monitored.
- The auto shutdown (ASD) relay is energized by the PCM for approximately three seconds.
- The fuel pump is energized through the fuel pump relay by the PCM. The fuel pump will operate for approximately three seconds unless the engine is operating or the starter motor is engaged.
- The O2S sensor heater element is energized via the ASD relay. The O2S sensor input is not used by

the PCM to calibrate air-fuel ratio during this mode of operation.

ENGINE START-UP MODE

This is an Open Loop mode. The following actions occur when the starter motor is engaged.

The powertrain control module (PCM) receives inputs from:

- Battery voltage
- Engine coolant temperature sensor
- Crankshaft position sensor
- Intake manifold air temperature sensor
- Manifold absolute pressure (MAP) sensor
- Throttle position sensor (TPS)
- Starter motor relay
- Camshaft position sensor signal

The PCM monitors the crankshaft position sensor. If the PCM does not receive a crankshaft position sensor signal within 3 seconds of cranking the engine, it will shut down the fuel injection system.

The fuel pump is activated by the PCM through the fuel pump relay.

Voltage is applied to the fuel injectors with the ASD relay via the PCM. The PCM will then control the injection sequence and injector pulse width by turning the ground circuit to each individual injector on and off.

The PCM determines the proper ignition timing according to input received from the crankshaft position sensor.

ENGINE WARM-UP MODE

This is an Open Loop mode. During engine warm-up, the powertrain control module (PCM) receives inputs from:

- Battery voltage
- Crankshaft position sensor
- Engine coolant temperature sensor
- Intake manifold air temperature sensor
- Manifold absolute pressure (MAP) sensor
- Throttle position sensor (TPS)
- Camshaft position sensor signal (in the distributor)
- Park/neutral switch (gear indicator signal—auto. trans. only)
- Air conditioning select signal (if equipped)
- Air conditioning request signal (if equipped)

Based on these inputs the following occurs:

• Voltage is applied to the fuel injectors with the ASD relay via the PCM. The PCM will then control the injection sequence and injector pulse width by turning the ground circuit to each individual injector on and off.

• The PCM adjusts engine idle speed through the idle air control (IAC) motor and adjusts ignition timing.

GENERAL INFORMATION (Continued)

- The PCM operates the A/C compressor clutch through the clutch relay. This is done if A/C has been selected by the vehicle operator and requested by the A/C thermostat.

- When engine has reached operating temperature, the PCM will begin monitoring O₂S sensor input. The system will then leave the warm-up mode and go into closed loop operation.

IDLE MODE

When the engine is at operating temperature, this is a Closed Loop mode. At idle speed, the powertrain control module (PCM) receives inputs from:

- Air conditioning select signal (if equipped)
- Air conditioning request signal (if equipped)
- Battery voltage
- Crankshaft position sensor
- Engine coolant temperature sensor
- Intake manifold air temperature sensor
- Manifold absolute pressure (MAP) sensor
- Throttle position sensor (TPS)
- Camshaft position sensor signal (in the distributor)

- Battery voltage
- Park/neutral switch (gear indicator signal—auto. trans. only)

- Oxygen sensors

Based on these inputs, the following occurs:

- Voltage is applied to the fuel injectors with the ASD relay via the PCM. The PCM will then control injection sequence and injector pulse width by turning the ground circuit to each individual injector on and off.

- The PCM monitors the O₂S sensor input and adjusts air-fuel ratio by varying injector pulse width. It also adjusts engine idle speed through the idle air control (IAC) motor.

- The PCM adjusts ignition timing by increasing and decreasing spark advance.

- The PCM operates the A/C compressor clutch through the clutch relay. This happens if A/C has been selected by the vehicle operator and requested by the A/C thermostat.

CRUISE MODE

When the engine is at operating temperature, this is a Closed Loop mode. At cruising speed, the powertrain control module (PCM) receives inputs from:

- Air conditioning select signal (if equipped)
- Air conditioning request signal (if equipped)
- Battery voltage
- Engine coolant temperature sensor
- Crankshaft position sensor
- Intake manifold air temperature sensor
- Manifold absolute pressure (MAP) sensor
- Throttle position sensor (TPS)

- Camshaft position sensor signal (in the distributor)

- Park/neutral switch (gear indicator signal—auto. trans. only)

- Oxygen (O₂S) sensors

Based on these inputs, the following occurs:

- Voltage is applied to the fuel injectors with the ASD relay via the PCM. The PCM will then adjust the injector pulse width by turning the ground circuit to each individual injector on and off.

- The PCM monitors the O₂S sensor input and adjusts air-fuel ratio. It also adjusts engine idle speed through the idle air control (IAC) motor.

- The PCM adjusts ignition timing by turning the ground path to the coil on and off.

- The PCM operates the A/C compressor clutch through the clutch relay. This happens if A/C has been selected by the vehicle operator and requested by the A/C thermostat.

ACCELERATION MODE

This is an Open Loop mode. The powertrain control module (PCM) recognizes an abrupt increase in throttle position or MAP pressure as a demand for increased engine output and vehicle acceleration. The PCM increases injector pulse width in response to increased throttle opening.

DECELERATION MODE

When the engine is at operating temperature, this is an Open Loop mode. During hard deceleration, the powertrain control module (PCM) receives the following inputs.

- Air conditioning select signal (if equipped)
- Air conditioning request signal (if equipped)
- Battery voltage
- Engine coolant temperature sensor
- Crankshaft position sensor
- Intake manifold air temperature sensor
- Manifold absolute pressure (MAP) sensor
- Throttle position sensor (TPS)
- Camshaft position sensor signal (in the distributor)

- Park/neutral switch (gear indicator signal—auto. trans. only)

- Vehicle speed sensor

If the vehicle is under hard deceleration with the proper rpm and closed throttle conditions, the PCM will ignore the oxygen sensor input signal. The PCM will enter a fuel cut-off strategy in which it will not supply a ground to the injectors. If a hard deceleration does not exist, the PCM will determine the proper injector pulse width and continue injection.

Based on the above inputs, the PCM will adjust engine idle speed through the idle air control (IAC) motor.

GENERAL INFORMATION (Continued)

The PCM adjusts ignition timing by turning the ground path to the coil on and off.

WIDE OPEN THROTTLE MODE

This is an Open Loop mode. During wide open throttle operation, the powertrain control module (PCM) receives the following inputs.

- Battery voltage
- Crankshaft position sensor
- Engine coolant temperature sensor
- Intake manifold air temperature sensor
- Manifold absolute pressure (MAP) sensor
- Throttle position sensor (TPS)
- Camshaft position sensor signal (in the distributor)

During wide open throttle conditions, the following occurs:

- Voltage is applied to the fuel injectors with the ASD relay via the PCM. The PCM will then control the injection sequence and injector pulse width by turning the ground circuit to each individual injector on and off. The PCM ignores the oxygen sensor input signal and provides a predetermined amount of additional fuel. This is done by adjusting injector pulse width.

- The PCM adjusts ignition timing by turning the ground path to the coil on and off.

IGNITION SWITCH OFF MODE

When ignition switch is turned to OFF position, the PCM stops operating the injectors, ignition coil, ASD relay and fuel pump relay.

DESCRIPTION AND OPERATION

POWERTRAIN CONTROL MODULE (PCM)

The powertrain control module (PCM) (Fig. 1) operates the fuel system. The PCM was formerly referred to as the SBEC or engine controller. The PCM is a pre-programmed, triple microprocessor digital computer. It regulates ignition timing, air-fuel ratio, emission control devices, charging system, certain transmission features, speed control, air conditioning compressor clutch engagement and idle speed. The PCM can adapt its programming to meet changing operating conditions.

The PCM receives input signals from various switches and sensors. Based on these inputs, the PCM regulates various engine and vehicle operations through different system components. These components are referred to as Powertrain Control Module (PCM) Outputs. The sensors and switches that provide inputs to the PCM are considered Powertrain Control Module (PCM) Inputs.

The PCM adjusts ignition timing based upon inputs it receives from sensors that react to: engine

rpm, manifold absolute pressure, engine coolant temperature, throttle position, transmission gear selection (automatic transmission), vehicle speed and the brake switch.

The PCM adjusts idle speed based on inputs it receives from sensors that react to: throttle position, vehicle speed, transmission gear selection, engine coolant temperature and from inputs it receives from the air conditioning clutch switch and brake switch.

Based on inputs that it receives, the PCM adjusts ignition coil dwell. The PCM also adjusts the generator charge rate through control of the generator field and provides speed control operation.

NOTE: PCM Inputs:

- A/C request (if equipped with factory A/C)
- A/C select (if equipped with factory A/C)
- Auto shutdown (ASD) sense
- Battery temperature
- Battery voltage
- Brake switch
- CCD bus (+) circuits
- CCD bus (-) circuits
- Camshaft position sensor signal
- Crankshaft position sensor
- Data link connection for DRB scan tool
- Engine coolant temperature sensor
- Fuel level
- Generator (battery voltage) output
- Ignition circuit sense (ignition switch in on/off/crank/run position)
 - Intake manifold air temperature sensor
 - Leak detection pump (switch) sense (if equipped)
 - Manifold absolute pressure (MAP) sensor
 - Oil pressure
 - Output shaft speed sensor
 - Overdrive/override switch
 - Oxygen sensors
 - Park/neutral switch (auto. trans. only)
 - Power ground
 - Sensor return
 - Signal ground
 - Speed control multiplexed single wire input
 - Throttle position sensor
 - Transmission governor pressure sensor
 - Transmission temperature sensor
 - Vehicle speed sensor

NOTE: PCM Outputs:

- A/C clutch relay
- Auto shutdown (ASD) relay
- CCD bus (+) circuits
- CCD bus (-) circuits
- Data link connection for DRB scan tool
- EGR valve control solenoid (if equipped)

DESCRIPTION AND OPERATION (Continued)

- EVAP canister purge solenoid
- Five volt sensor supply (primary)
- Five volt sensor supply (secondary)
- Fuel injectors
- Fuel pump relay
- Generator field driver (-)
- Generator field driver (+)
- Generator lamp (if equipped)
- Idle air control (IAC) motor
- Ignition coil
- Leak detection pump
- Malfunction indicator lamp (Check engine lamp).

Driven through CCD circuits.

- Overdrive indicator lamp (if equipped)
- Speed control vacuum solenoid
- Speed control vent solenoid
- Tachometer (if equipped). Driven through CCD circuits.
- Transmission convertor clutch circuit
- Transmission 3-4 shift solenoid
- Transmission relay
- Transmission temperature lamp (if equipped)
- Transmission variable force solenoid

AIR CONDITIONING (A/C) CONTROLS—PCM INPUT

The A/C control system information applies to factory installed air conditioning units.

A/C SELECT SIGNAL: When the A/C switch is in the ON position, an input signal is sent to the powertrain control module (PCM). The signal informs the PCM that the A/C has been selected. The PCM adjusts idle speed to a pre-programmed rpm through the idle air control (IAC) motor to compensate for increased engine load.

A/C REQUEST SIGNAL: Once A/C has been selected, the powertrain control module (PCM) receives the A/C request signal from the clutch cycling pressure switch. The input indicates that the evaporator pressure is in the proper range for A/C application. The PCM uses this input to cycle the A/C compressor clutch (through the A/C relay). It will also determine the correct engine idle speed through the idle air control (IAC) motor position.

If the A/C low-pressure switch or high-pressure switch opens (indicating a low or high refrigerant pressure), the PCM will not receive an A/C request signal. The PCM will then remove the ground from the A/C relay. This will deactivate the A/C compressor clutch.

If the switch opens, (indicating that evaporator is not in proper pressure range), the PCM will not receive the A/C request signal. The PCM will then remove the ground from the A/C relay, deactivating the A/C compressor clutch.

AUTOMATIC SHUTDOWN (ASD) RELAY SENSE—PCM INPUT

A 12 volt signal at this input indicates to the PCM that the ASD has been activated. The ASD relay is located in the Power Distribution Center (PDC). The PDC is located in the engine compartment (Fig. 2). Refer to label on PDC cover for relay location. The relay is used to connect the oxygen sensor heater element, ignition coil and fuel injectors to 12 volt + power supply.

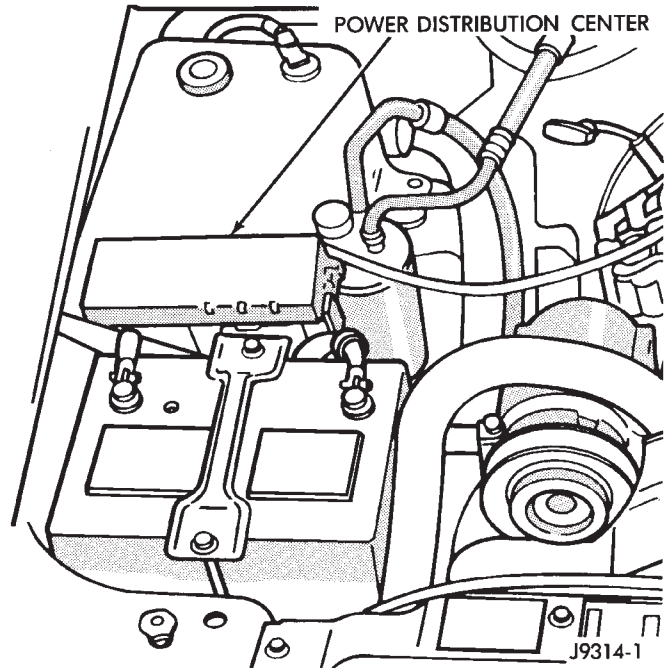


Fig. 2 Power Distribution Center (PDC)

This input is used only to sense that the ASD relay is energized. If the powertrain control module (PCM) does not see 12 volts at this input when the ASD should be activated, it will set a diagnostic trouble code (DTC).

BATTERY TEMPERATURE SENSOR—PCM INPUT

Provides a signal to the PCM corresponding to the battery temperature. Refer to Group 8C, Charging System for additional information.

BATTERY VOLTAGE—PCM INPUT

The battery voltage input provides power to the Powertrain Control Module (PCM). It also informs the PCM what voltage level is supplied to the ignition coil and fuel injectors.

If battery voltage is low, the PCM will increase injector pulse width (period of time that the injector is energized). This is done to compensate for the reduced flow through injector caused by the lowered voltage.

DESCRIPTION AND OPERATION (Continued)

BRAKE SWITCH—PCM INPUT

When the brake light switch is activated, the Powertrain Control Module (PCM) receives an input indicating that the brakes are being applied. After receiving this input, the PCM maintains idle speed to a scheduled rpm through control of the Idle Air Control (IAC) motor. The brake switch input is also used to supply/deny power to the speed control servo solenoids.

FIVE VOLT SENSOR SUPPLY—PRIMARY

Supplies the required 5 volt power source to the crankshaft position sensor, camshaft position sensor, MAP sensor and throttle position sensor.

FIVE VOLT SENSOR SUPPLY—SECONDARY

Supplies the required 5 volt source to the vehicle speed sensor.

FUEL LEVEL SENSOR—PCM INPUT

The Powertrain Control Module (PCM) sends a 5 volt signal to the fuel level sensor (fuel gauge sending unit). The fuel level sensor will then return a signal to the PCM to indicate fuel level. The purpose of this feature is to prevent a false setting of misfire and fuel system monitor trouble codes. This is if the fuel level is less than approximately 15 percent, or, if equipped with a Leak Detection Pump (LDP), more than approximately 85 percent of its rated capacity. This input is also used to send a signal to the PCM for fuel gauge operation via the CCD bus circuits.

CAMSHAFT POSITION SENSOR—PCM INPUT

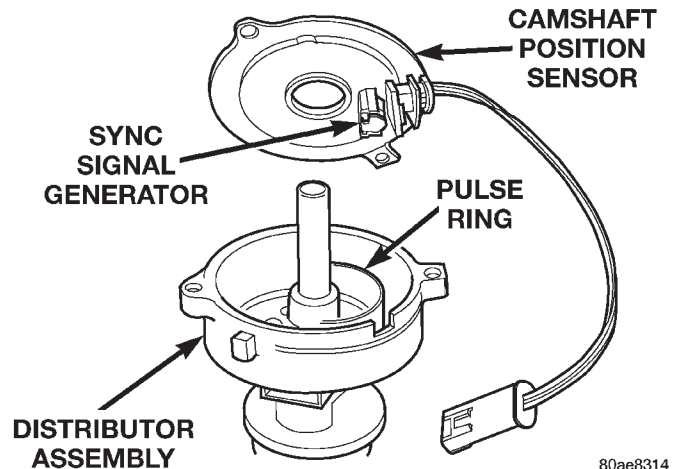
A sync signal is provide by the camshaft position sensor. The sensor located in the distributor on all 4.0L/5.2L/5.9L engines (Fig. 3). The sync signal from this sensor works in conjunction with the crankshaft position sensor to provide the powertrain control module (PCM) with inputs. This is done to establish and maintain correct injector firing order.

Refer to Camshaft Position Sensor in Group 8D, Ignition System for more information.

CRANKSHAFT POSITION SENSOR—5.2L/5.9L ENGINES—PCM INPUT

This sensor is a hall effect device that detects notches in the flywheel (manual transmission) or flexplate (automatic transmission).

This sensor is used to indicate to the powertrain control module (PCM) that a spark and or fuel injection event is to be required. The output from this sensor, in conjunction with the camshaft position sensor signal, is used to differentiate between fuel injection and spark events. It is also used to synchronize the fuel injectors with their respective cylinders.



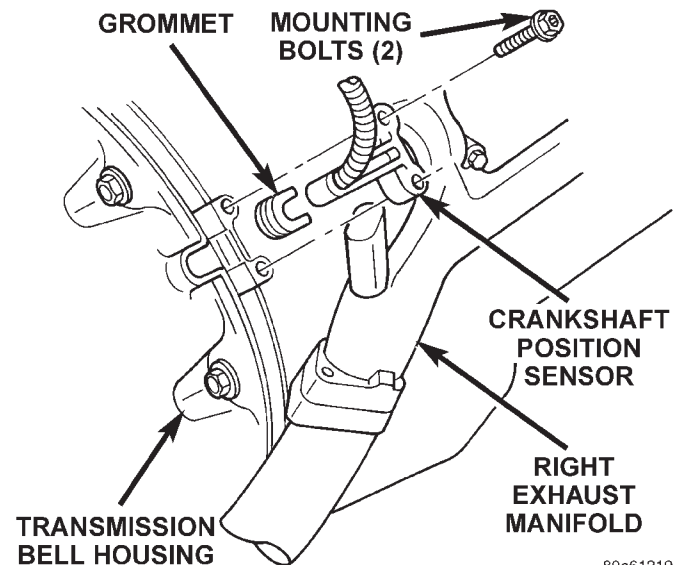
80ae8314

Fig. 3 Camshaft Position Sensor—Typical (5.2L/5.9L Distributor Shown)

The sensor is bolted to the cylinder block near the rear of the right cylinder head (Fig. 4).

Refer to Group 8D, Ignition System for more crankshaft position sensor information.

The engine will not operate if the PCM does not receive a crankshaft position sensor input.



80a61219

Fig. 4 Crankshaft Position Sensor—5.2L/5.9L Engines

CRANKSHAFT POSITION SENSOR—4.0L ENGINE—PCM INPUT

This sensor is a hall effect device that detects notches in the flywheel (manual transmission) or flexplate (automatic transmission).

This sensor is used to indicate to the powertrain control module (PCM) that a spark and or fuel injection event is to be required. The output from this sensor, in conjunction with the camshaft position sen-

DESCRIPTION AND OPERATION (Continued)

sor signal, is used to differentiate between fuel injection and spark events. It is also used to synchronize the fuel injectors with their respective cylinders.

The sensor is bolted to the transmission bellhousing (Fig. 5).

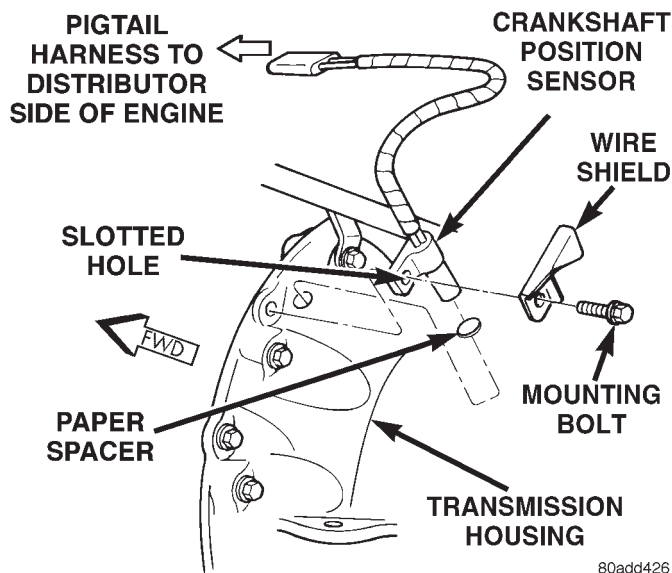


Fig. 5 Crankshaft Position Sensor—4.0L Engine

Refer to Group 8D, Ignition System for more crankshaft position sensor information.

The engine will not operate if the PCM does not receive a crankshaft position sensor input.

ENGINE COOLANT TEMPERATURE SENSOR—5.2L/5.9L ENGINES—PCM INPUT

The engine coolant temperature sensor is installed next to the thermostat housing (Fig. 6) and protrudes into the water jacket. The sensor provides an input voltage to the powertrain control module (PCM) relating coolant temperature. The PCM uses this input along with inputs from other sensors to determine injector pulse width and ignition timing. As coolant temperature varies, the coolant temperature sensor resistance will change. This change in resistance results in a different input voltage to the PCM.

When the engine is cold, the PCM will operate in Open Loop cycle. It will demand slightly richer air-fuel mixtures and higher idle speeds. This is done until normal operating temperatures are reached.

ENGINE COOLANT TEMPERATURE SENSOR—4.0L ENGINE—PCM INPUT

The engine coolant temperature sensor is installed in the thermostat housing (Fig. 7) and protrudes into the water jacket. The sensor provides an input voltage to the powertrain control module (PCM) relating coolant temperature. The PCM uses this input along with inputs from other sensors to determine injector

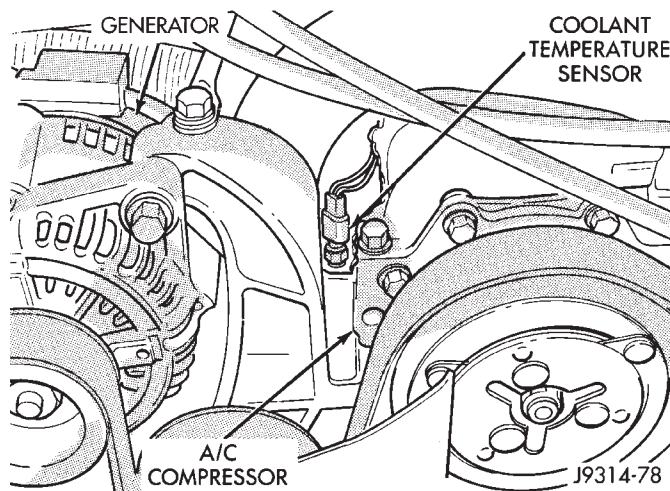


Fig. 6 Engine Coolant Temperature Sensor—5.2L/5.9L Engines

pulse width and ignition timing. As coolant temperature varies, the coolant temperature sensor's resistance changes. The change in resistance results in a different input voltage to the PCM.

When the engine is cold, the PCM will operate in Open Loop cycle. It will demand slightly richer air-fuel mixtures and higher idle speeds. This is done until normal operating temperatures are reached.

Refer to Open Loop/Closed Loop Modes of Operation in this section of the group for more information.

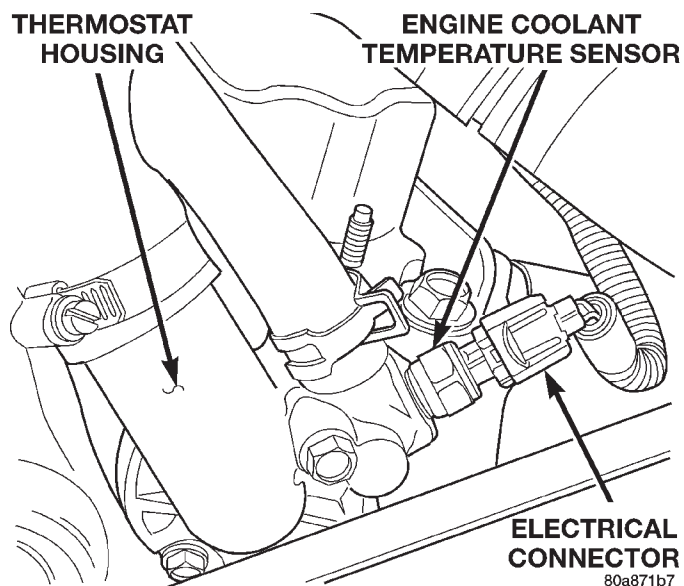


Fig. 7 Engine Coolant Temperature Sensor—4.0L Engine—Typical

GENERATOR OUTPUT—PCM INPUT

Provides a charging system voltage input to the Powertrain Control Module (PCM). It is sensed at the battery input to the PCM.

DESCRIPTION AND OPERATION (Continued)

OXYGEN SENSOR (O2S)—PCM INPUT

Two heated O2S sensors are used. The sensors produce voltages from 0 to 1 volt, depending upon the oxygen content of the exhaust gas in the exhaust manifold. When a large amount of oxygen is present (caused by a lean air/fuel mixture), the sensors produce a low voltage. When there is a lesser amount present (rich air/fuel mixture) it produces a higher voltage. By monitoring the oxygen content and converting it to electrical voltage, the sensors act as a rich-lean switch.

In Closed Loop operation, the PCM monitors the O2S sensor input (along with other inputs) and adjusts the injector pulse width accordingly. During Open Loop operation, the PCM ignores the O2 sensor input. The PCM adjusts injector pulse width based on preprogrammed (fixed) values and inputs from other sensors.

The oxygen sensors are equipped with a heating element that keeps the sensors at proper operating temperature during all operating modes. Maintaining correct sensor temperature at all times allows the system to enter into closed loop operation sooner. Also, it allows the system to remain in closed loop operation during periods of extended idle.

The Automatic Shutdown (ASD) relay supplies battery voltage to both the upstream and downstream heated oxygen sensors. The oxygen sensors are equipped with a heating element. The heating elements reduce the time required for the sensors to reach operating temperature.

UPSTREAM HEATED OXYGEN SENSOR

The upstream O2S sensor is located near the inlet end of the catalytic converter. It provides an input voltage to the PCM. The input tells the PCM the oxygen content of the exhaust gas. The PCM uses this information to fine tune the air/fuel ratio by adjusting injector pulse width.

DOWNSTREAM HEATED OXYGEN SENSOR

The downstream heated oxygen sensor is located near the outlet end of the catalytic converter. The downstream heated oxygen sensor input is used to detect catalytic converter deterioration. As the converter deteriorates, the input from the downstream sensor begins to match the upstream sensor input except for a slight time delay. By comparing the downstream heated oxygen sensor input to the input from the upstream sensor, the PCM calculates catalytic converter efficiency.

When the catalytic converter efficiency drops below emission standards, the PCM stores a diagnostic trouble code and illuminates the Malfunction Indicator Lamp (MIL). For more information, refer to Group 25, Emission Control Systems.

IGNITION CIRCUIT SENSE—PCM INPUT

The ignition circuit sense input tells the Powertrain Control Module (PCM) the ignition switch has energized the ignition circuit. Refer to the wiring diagrams for circuit information.

INTAKE MANIFOLD AIR TEMPERATURE SENSOR—5.2L/5.9L ENGINES—PCM INPUT

The intake manifold air temperature sensor is installed in the intake manifold with the sensor element extending into the air stream (Fig. 8). The sensor provides an input voltage to the powertrain control module (PCM) indicating intake manifold air temperature. The input is used along with inputs from other sensors to determine injector pulse width. As the temperature of the air-fuel stream in the manifold varies, the sensor resistance changes. This results in a different input voltage to the PCM.

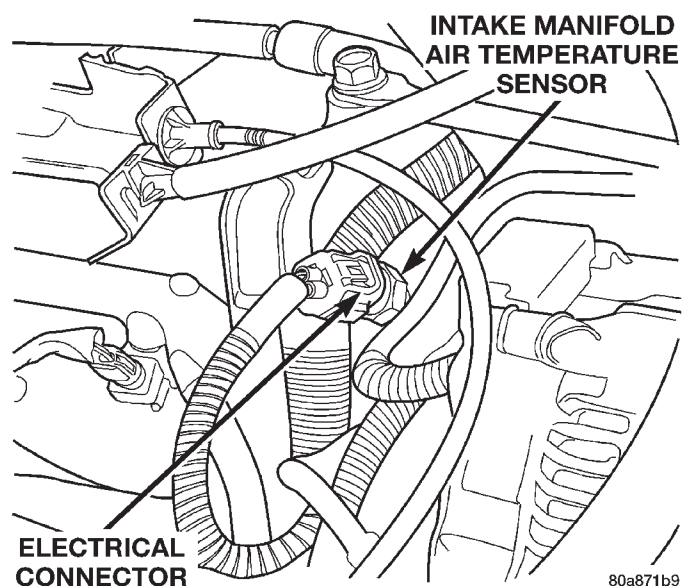


Fig. 8 Intake Manifold Air Temperature Sensor—5.2L/5.9L V-8 Engines—Typical

INTAKE MANIFOLD AIR TEMPERATURE SENSOR—4.0L ENGINE—PCM INPUT

The intake manifold air temperature sensor is installed in the intake manifold with the sensor element extending into the air stream (Fig. 9). The sensor provides an input voltage to the powertrain control module (PCM) indicating intake manifold air temperature. The input is used along with inputs from other sensors to determine injector pulse width. As the temperature of the air-fuel stream in the manifold varies, the sensor resistance changes. This results in a different input voltage to the PCM.

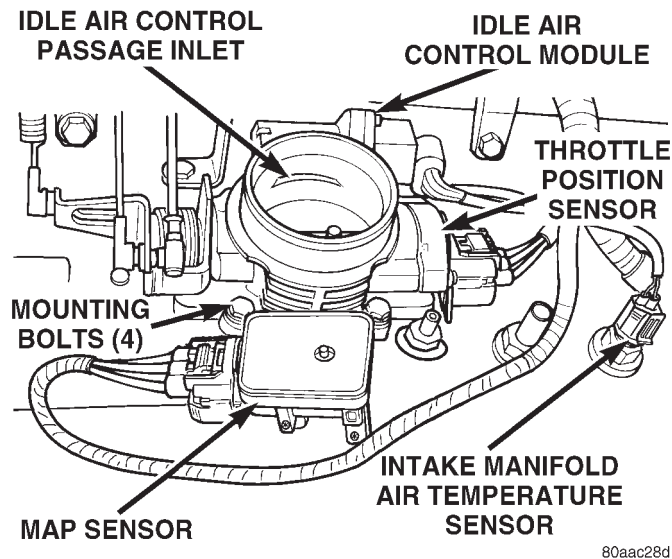
DESCRIPTION AND OPERATION (Continued)

Fig. 9 Throttle Body Sensor Locations—4.0L Engine

LEAK DETECTION PUMP (SWITCH) SENSE—PCM INPUT

Provides an input to the PCM that the leak detection pump (LDP) has been activated. Refer to Group 25, Emission Control System for LDP information.

MANIFOLD ABSOLUTE PRESSURE (MAP) SENSOR—5.2L/5.9L ENGINES—PCM INPUT

The MAP sensor reacts to absolute pressure in the intake manifold. It provides an input voltage to the powertrain control module (PCM). As engine load changes, manifold pressure varies. The change in manifold pressure causes MAP sensor voltage to change. The change in MAP sensor voltage results in a different input voltage to the PCM. The input voltage level supplies the PCM with information about ambient barometric pressure during engine start-up (cranking) and engine load while the engine is running. The PCM uses this input along with inputs from other sensors to adjust air-fuel mixture.

The MAP sensor is mounted on the side of the engine throttle body (Fig. 10). The sensor is connected to the throttle body with a rubber L-shaped fitting.

MANIFOLD ABSOLUTE PRESSURE (MAP) SENSOR—4.0L ENGINE—PCM INPUT

The MAP sensor reacts to absolute pressure in the intake manifold. It provides an input voltage to the powertrain control module (PCM). As engine load changes, manifold pressure varies. The change in manifold pressure causes MAP sensor voltage to change. The change in MAP sensor voltage results in a different input voltage to the PCM. The input voltage level supplies the PCM with information about ambient barometric pressure during engine start-up

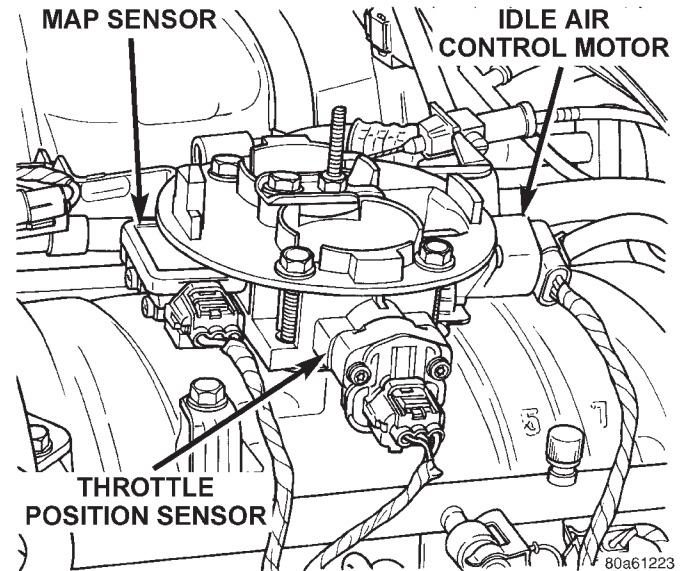


Fig. 10 MAP and Throttle Position Sensor Location—5.2L/5.9L Engines

(cranking) and engine load while the engine is running. The PCM uses this input along with inputs from other sensors to adjust air-fuel mixture.

The MAP sensor is mounted on the side of the engine throttle body (Fig. 9). The sensor is connected to the throttle body with a rubber L-shaped fitting.

OIL PRESSURE SENSOR—PCM INPUT

Sends a signal from the oil pressure sending unit to the Powertrain Control Module (PCM) relating to engine oil pressure.

OUTPUT SHAFT SPEED SENSOR—PCM INPUT

This sensor generates a signal to the PCM relating to the speed of the transmission main drive shaft. This input is used with 4-speed electronic transmissions only.

OVERDRIVE/OVERRIDE SWITCH-PCM INPUT

On vehicles equipped with an automatic transmission and overdrive, the powertrain control module (PCM) regulates the 3-4 overdrive up-shift and down-shift through the overdrive solenoid. This solenoid is located in the transmission. An overdrive/override push-button switch is located on the instrument panel.

The overdrive/override push-button switch is normally open (overdrive allowed) when the lamp is not illuminated. It momentarily closes (overdrive not allowed) when the operator presses the switch and the lamp is illuminated. Overdrive will revert to ON (lamp off) each time the ignition switch is turned on. The transmission downshifts if the operator presses the override switch while in overdrive.

Refer to Group 21 for more transmission information.

DESCRIPTION AND OPERATION (Continued)**POWER GROUND**

The power ground is used to control ground circuits for the following powertrain control module (PCM) loads:

- Generator field winding
- Fuel injectors
- Ignition coil
- Certain relays/solenoids

SENSOR RETURN—PCM INPUT

Sensor Return provides a low noise ground reference for all engine control system sensors.

SIGNAL GROUND—PCM INPUT

Signal ground provides a low noise ground to the data link connector.

SPEED CONTROL SWITCHES—PCM INPUT

Two separate speed control switch modules are mounted on the steering wheel to the left and right side of the driver's airbag module. Within the two switch modules, five **momentary** contact switches, supporting seven different speed control functions are used. The outputs from these switches are filtered into one input. The Powertrain Control Module (PCM) determines which output has been applied through **resistive multiplexing**. The input circuit voltage is measured by the PCM to determine which switch function has been selected.

A speed control indicator lamp, located on the instrument panel cluster is energized by the PCM via the CCD Bus. This occurs when speed control system power has been turned ON, and the engine is running.

The two switch modules are labeled: ON/OFF, SET, RESUME/ACCEL, CANCEL and COAST. Refer to Group 8H, Speed Control System for more information.

TRANSMISSION PARK/NEUTRAL SWITCH—PCM INPUT

The park/neutral switch is located on the transmission housing and provides an input to the Powertrain Control Module (PCM). This will indicate that the automatic transmission is in Park, Neutral or a drive gear selection. This input is used to determine idle speed (varying with gear selection), fuel injector pulse width and ignition timing advance. Refer to Group 21, Transmissions, for testing, replacement and adjustment information.

TRANSMISSION GOVERNOR PRESSURE SENSOR—PCM INPUT

Provides a signal proportional to the transmission governor pressure. It provides feedback for control of the governor pressure solenoid, which regulates

transmission governor pressure. This input is used with 4-speed electronic transmissions only.

TRANSMISSION TEMPERATURE SENSOR—PCM INPUT

This input is used in the shift operation for 4-speed electronic transmissions only. The temperature data is used for: torque converter clutch operation, overdrive shift, low temperature shift compensation, wide open throttle shift strategy and governor pressure transducer calibration.

THROTTLE POSITION SENSOR (TPS)—5.2L/5.9L ENGINES—PCM INPUT

The throttle position sensor (TPS) is mounted on the throttle body (Fig. 10). The TPS is a variable resistor that provides the powertrain control module (PCM) with an input signal (voltage) that represents throttle blade position. The sensor is connected to the throttle blade shaft. As the position of the throttle blade changes, the resistance of the TPS changes.

The PCM supplies approximately 5 volts to the TPS. The TPS output voltage (input signal to the PCM) represents the throttle blade position. The PCM receives an input signal voltage from the TPS. This will vary in an approximate range of from .25 volts at minimum throttle opening (idle), to 4.8 volts at wide open throttle. Along with inputs from other sensors, the PCM uses the TPS input to determine current engine operating conditions. In response to engine operating conditions, the PCM will adjust fuel injector pulse width and ignition timing.

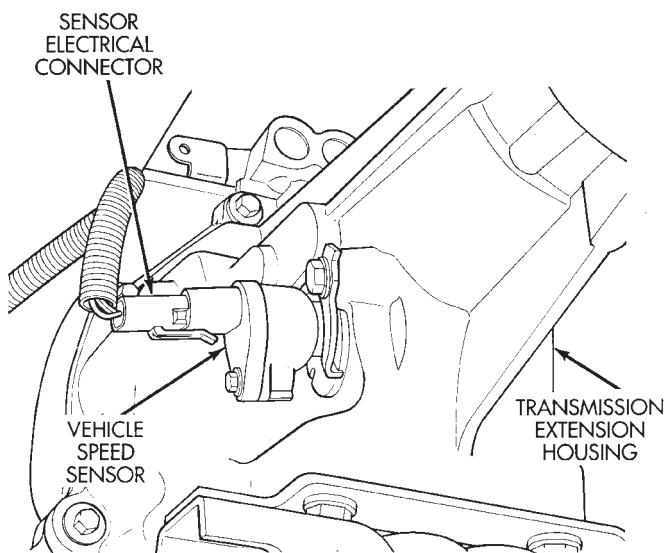
THROTTLE POSITION SENSOR (TPS)—4.0L ENGINE—PCM INPUT

The throttle position sensor (TPS) is mounted on the throttle body (Fig. 9). The TPS is a variable resistor that provides the powertrain control module (PCM) with an input signal (voltage) that represents throttle blade position. The sensor is connected to the throttle blade shaft. As the position of the throttle blade changes, the resistance of the TPS changes.

The PCM supplies approximately 5 volts to the TPS. The TPS output voltage (input signal to the PCM) represents the throttle blade position. The PCM receives an input signal voltage from the TPS. This will vary in an approximate range of from .25 volts at minimum throttle opening (idle), to 4.8 volts at wide open throttle. Along with inputs from other sensors, the PCM uses the TPS input to determine current engine operating conditions. In response to engine operating conditions, the PCM will adjust fuel injector pulse width and ignition timing.

DESCRIPTION AND OPERATION (Continued)**VEHICLE SPEED AND DISTANCE SENSOR—PCM INPUT**

The vehicle speed sensor is located on the speedometer pinion gear adapter (Fig. 11) or (Fig. 12). The pinion gear adapter is located on the extension housing of the transmission (drivers side—2WD), or on the transfer case (4WD). The sensor input is used by the powertrain control module (PCM) to determine vehicle speed and distance traveled.



J9414-60

Fig. 11 Vehicle Speed Sensor Location—2WD—Typical

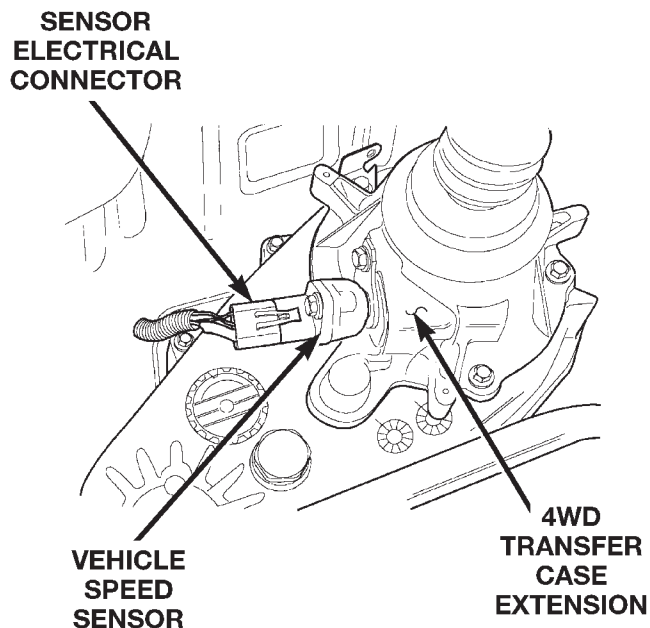
The speed sensor generates 8 pulses per sensor revolution. These signals, in conjunction with a closed throttle signal from the throttle position sensor, indicate a closed throttle deceleration to the PCM. When the vehicle is stopped at idle, a closed throttle signal is received by the PCM (but a speed sensor signal is not received).

Under deceleration conditions, the PCM adjusts the idle air control (IAC) motor to maintain a desired MAP value. Under idle conditions, the PCM adjusts the IAC motor to maintain a desired engine speed.

AIR CONDITIONING (A/C) CLUTCH RELAY—PCM OUTPUT

The A/C relay is located in the Power Distribution Center (PDC). The PDC is located in the engine compartment (Fig. 13). Refer to label on PDC cover for relay location.

The powertrain control module (PCM) activates the A/C compressor through the A/C clutch relay. The PCM regulates A/C compressor operation by switch-



80a35409

Fig. 12 Vehicle Speed Sensor Location—4WD—Typical

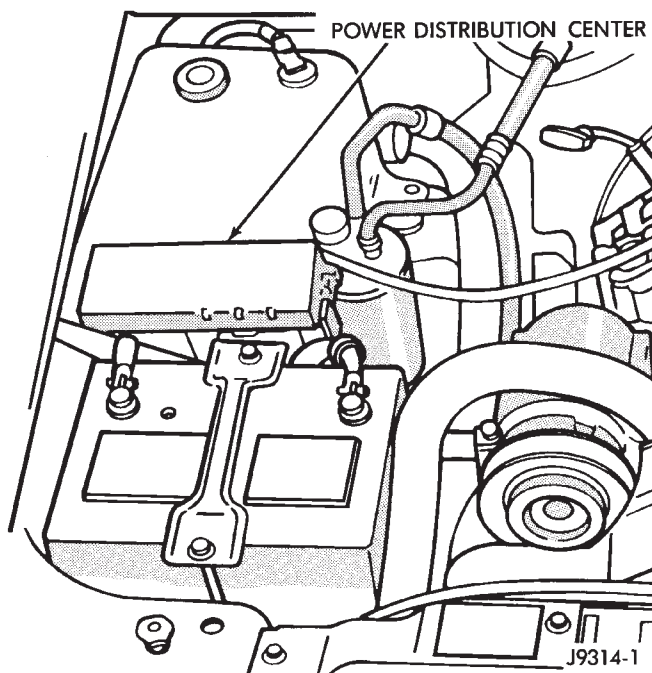


Fig. 13 Power Distribution Center (PDC)

ing the ground circuit for the A/C clutch relay on and off.

When the PCM receives a request for A/C from A/C evaporator switch, it will adjust idle air control (IAC) motor position. This is done to increase idle speed. The PCM will then activate the A/C clutch through the A/C clutch relay. The PCM adjusts idle air control (IAC) stepper motor position to compensate for increased engine load from the A/C compressor.

DESCRIPTION AND OPERATION (Continued)

By switching the ground path for the relay on and off, the PCM is able to cycle the A/C compressor clutch. This is based on changes in engine operating conditions. If, during A/C operation, the PCM senses abnormally low idle speeds it will de-energize the relay. This prevents A/C clutch engagement. The relay will remain de-energized until the idle speed increases. The PCM will also de-energize the relay if coolant temperature exceeds 125°C (257°F) or low or high system pressure exists.

AUTO SHUTDOWN (ASD) RELAY—PCM OUTPUT

The ASD relay is located in the Power Distribution Center (PDC).

The ASD supplies battery voltage to the fuel injectors, ignition coil and oxygen (O₂S) sensor heating elements. The ground circuit for the coil in the ASD relay is controlled by the powertrain control module (PCM). The PCM operates the relay by switching the ground circuit on and off.

CCD BUS (+/-) CIRCUITS-PCM OUTPUTS

The Powertrain Control Module (PCM) sends certain output signals through the CCD bus circuits. These signals are used to control certain instrument panel located items and to determine certain identification numbers.

Refer to Group 8E, Instrument Panel and Gauges for additional information.

DATA LINK CONNECTOR—PCM INPUT AND OUTPUT

The 16-way data link connector (diagnostic scan tool connector) links the Diagnostic Readout Box (DRB) scan tool or the Mopar Diagnostic System (MDS) with the powertrain control module (PCM). The data link connector is located under the instrument panel to the left of the steering column (Fig. 14). For operation of the DRB scan tool, refer to the appropriate Powertrain Diagnostic Procedures service manual.

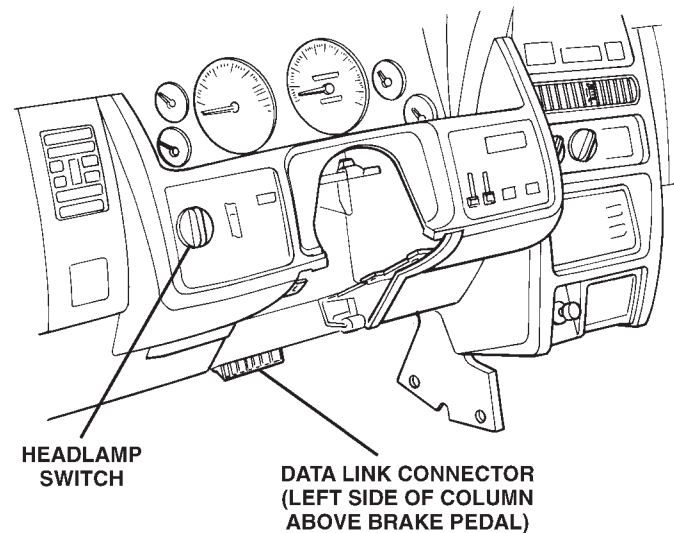
DUTY CYCLE EVAP PURGE SOLENOID VALVE-PCM OUTPUT

Refer to Group 25, Emission Control System for information.

FUEL INJECTORS—5.2L/5.9L ENGINES—PCM OUTPUT

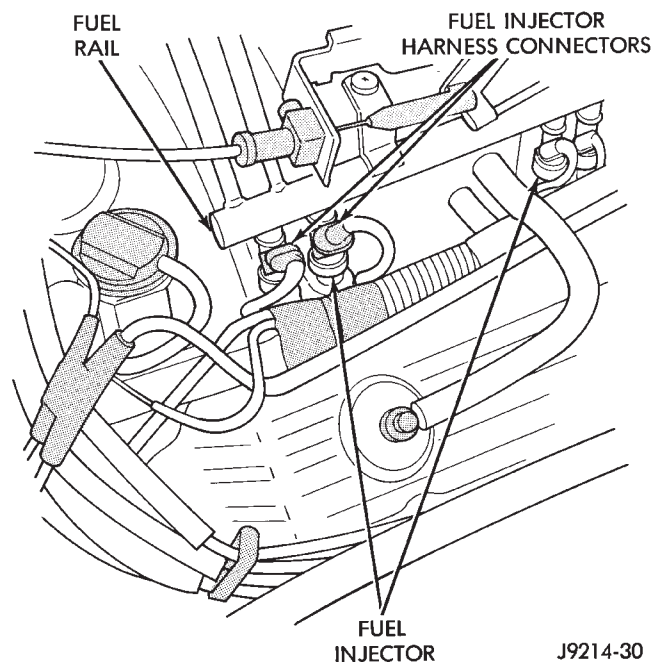
The fuel injectors are attached to the fuel rail (Fig. 15). 5.2L/5.9L V-8 engines use eight injectors.

The nozzle ends of the injectors are positioned into openings in the intake manifold just above the intake valve ports of the cylinder head. The engine wiring harness connector for each fuel injector is equipped with an attached numerical tag (INJ 1, INJ 2 etc.).



80a07536

Fig. 14 Data Link Connector Location



J9214-30

Fig. 15 Fuel Injectors—5.2L/5.9L Engines—Typical

This is used to identify each fuel injector with its respective cylinder number.

The injectors are energized individually in a sequential order by the powertrain control module (PCM). The PCM will adjust injector pulse width by switching the ground path to each individual injector on and off. Injector pulse width is the period of time that the injector is energized. The PCM will adjust injector pulse width based on various inputs it receives.

During start up, battery voltage is supplied to the injectors through the ASD relay. When the engine is operating, voltage is supplied by the charging sys-

DESCRIPTION AND OPERATION (Continued)

tem. The PCM determines injector pulse width based on various inputs.

FUEL INJECTORS—4.0L ENGINE—PCM OUTPUT

Six individual fuel injectors are used with the 4.0L 6-cylinder engine. The injectors are attached to the fuel rail (Fig. 16).

The nozzle ends of the injectors are positioned into openings in the intake manifold just above the intake valve ports of the cylinder head. The engine wiring harness connector for each fuel injector is equipped with an attached numerical tag (INJ 1, INJ 2 etc.). This is used to identify each fuel injector.

The injectors are energized individually in a sequential order by the powertrain control module (PCM). The PCM will adjust injector pulse width by switching the ground path to each individual injector on and off. Injector pulse width is the period of time that the injector is energized. The PCM will adjust injector pulse width based on various inputs it receives.

During start up, battery voltage is supplied to the injectors through the ASD relay. When the engine is operating, voltage is supplied by the charging system. The PCM determines injector pulse width based on various inputs.

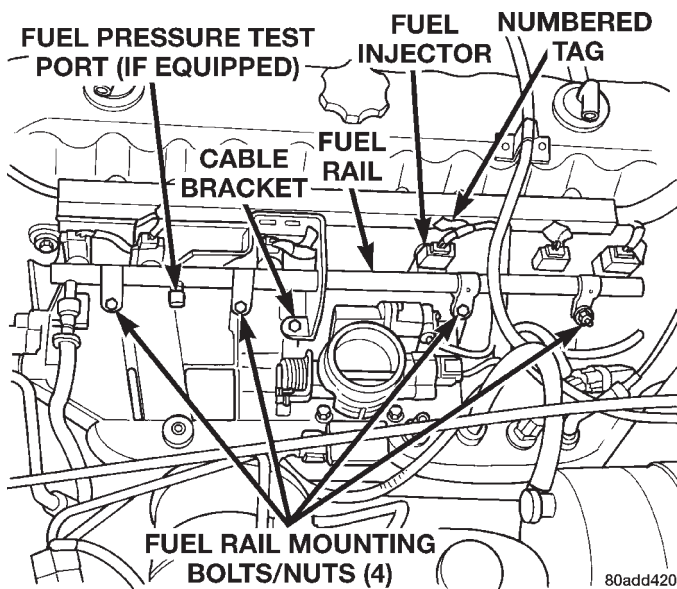


Fig. 16 Fuel Injectors—4.0L Engine

FUEL PUMP RELAY-PCM OUTPUT

The PCM energizes the electric fuel pump through the fuel pump relay. Battery voltage is applied to the fuel pump relay when the ignition key is ON. The relay is energized when a ground signal is provided by the PCM.

The fuel pump will operate for approximately three seconds unless the engine is operating or the starter motor is engaged.

The fuel pump relay is located in the Power Distribution Center (PDC).

GENERATOR FIELD SOURCE (+)—PCM OUTPUT

This output from the Powertrain Control Module (PCM) regulates charging system voltage to the generator field source (+) circuit. The voltage range is 12.9 to 15.0 volts. Models of previous years had used the ASD relay (directly) to apply the 12 volt + power supply to the generator field source (+) circuit. Refer to Groups 8A and 8C for charging system information.

GENERATOR FIELD DRIVER (-)—PCM OUTPUT

This output from the Powertrain Control Module (PCM) regulates charging system ground control to the generator field driver (-) circuit. Refer to Groups 8A and 8C for charging system information.

GENERATOR LAMP—PCM OUTPUT

If the powertrain control module (PCM) senses a low charging condition in the charging system, it will illuminate the generator lamp (if equipped) on the instrument panel. This is done through the CCD Bus circuits. For example, during low idle with all accessories turned on, the lamp may momentarily go on. Once the PCM corrects idle speed to a higher rpm, the lamp will go out. Refer to Groups 8A and 8C for charging system information.

IDLE AIR CONTROL (IAC) MOTOR—5.2L/5.9L ENGINES—PCM OUTPUT

The IAC motor is mounted to the back of the throttle body (Fig. 10) and is controlled by the powertrain control module (PCM).

The throttle body has an air control passage that provides air for the engine at idle (the throttle plate is closed). The IAC motor pintle protrudes into the air control passage (Fig. 17) and regulates air flow through it. Based on various sensor inputs, the powertrain control module (PCM) adjusts engine idle speed by moving the IAC motor pintle in and out of the air control passage. The IAC motor is positioned when the ignition key is turned to the On position.

A (factory adjusted) set screw is used to mechanically limit the position of the throttle body throttle plate. **Never attempt to adjust the engine idle speed using this screw.** All idle speed functions are controlled by the PCM.

IDLE AIR CONTROL (IAC) MOTOR—4.0L ENGINE—PCM OUTPUT

The IAC motor is mounted on the throttle body (Fig. 9) and is controlled by the powertrain control module (PCM).

DESCRIPTION AND OPERATION (Continued)

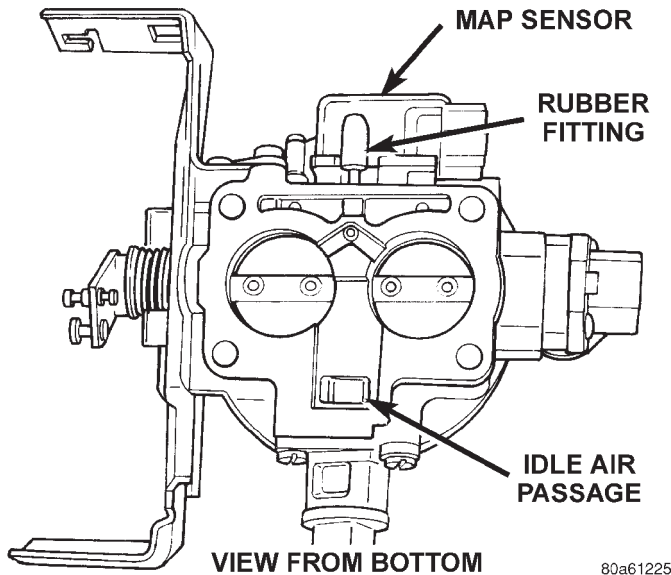


Fig. 17 Throttle Body Air Control Passage—5.2L/5.9L Engines—Typical

The throttle body has an air control passage that provides air for the engine at idle (the throttle plate is closed). The IAC motor pintle protrudes into the air control passage and regulates air flow through it. Based on various sensor inputs, the powertrain control module (PCM) adjusts engine idle speed by moving the IAC motor pintle in and out of the air control passage. The IAC motor is positioned when the ignition key is turned to the On position.

A (factory adjusted) set screw is used to mechanically limit the position of the throttle body throttle plate. **Never attempt to adjust the engine idle speed using this screw.** All idle speed functions are controlled by the PCM.

IGNITION COIL—5.2L/5.9L ENGINES—PCM OUTPUT

System voltage is supplied to the ignition coil positive terminal. The powertrain control module (PCM) operates the ignition coil. **Base (initial) ignition timing is not adjustable.** The PCM adjusts ignition timing to meet changing engine operating conditions.

The ignition coil is located near the front of the right cylinder head (Fig. 18).

Refer to Group 8D, Ignition System for additional information.

IGNITION COIL—4.0L ENGINES—PCM OUTPUT

System voltage is supplied to the ignition coil positive terminal. The powertrain control module (PCM) operates the ignition coil. **Base (initial) ignition timing is not adjustable.** The PCM adjusts ignition timing to meet changing engine operating conditions.

The ignition coil is located near the distributor (Fig. 19).

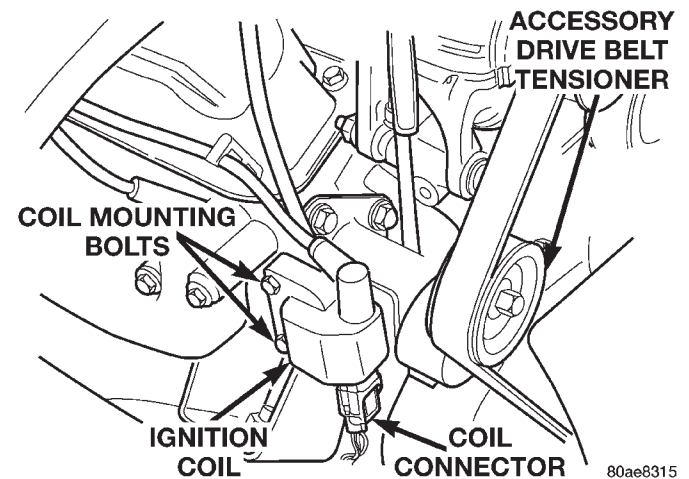


Fig. 18 Ignition Coil—5.2L/5.9L Engines—Typical

Refer to Group 8D, Ignition System for additional information.

LEAK DETECTION PUMP—PCM OUTPUT

Certain engines with certain emissions packages are equipped with a leak detection pump (LDP). The LDP is activated through this PCM output. Refer to Group 25, Emission Control System for additional information.

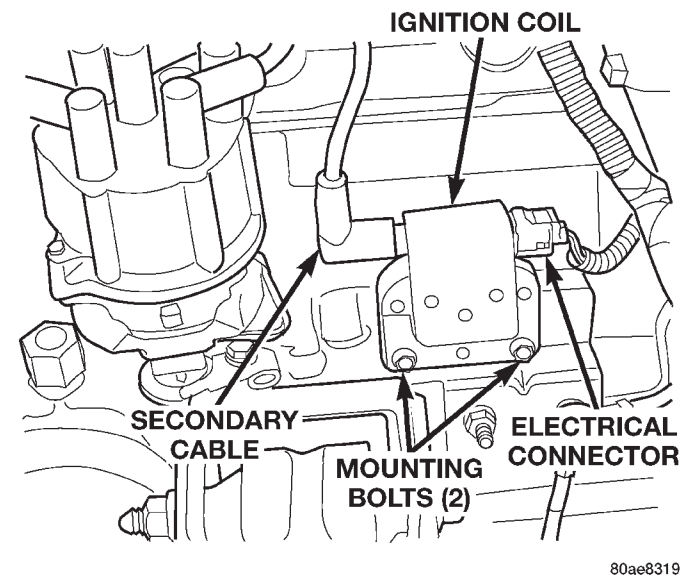


Fig. 19 Ignition Coil—4.0L Engine

MALFUNCTION INDICATOR LAMP—PCM OUTPUT

Refer to Group 25, Emission Control System for information.

OVERDRIVE LAMP—PCM OUTPUT

This circuit controls a signal for the operation of the instrument panel mounted push-button overdrive lamp switch. When the lamp is illuminated, the overdrive is disengaged.

DESCRIPTION AND OPERATION (Continued)**SPEED CONTROL SOLENOIDS—PCM OUTPUT**

Speed control operation is regulated by the powertrain control module (PCM). The PCM controls the vacuum to the throttle actuator through the speed control vacuum and vent solenoids. Refer to Group 8H for Speed Control Information.

TACHOMETER—PCM OUTPUT

The powertrain control module (PCM) supplies engine rpm values to the instrument cluster tachometer. Refer to Group 8E for tachometer information.

THREE-FOUR SHIFT SOLENOID—PCM OUTPUT

This output is used to control the transmission three-four shift solenoid. It is used on 4-speed electronically controlled automatic transmissions only.

TORQUE CONVERTOR CLUTCH (TCC) SOLENOID—PCM OUTPUT

This circuit controls operation of the transmission mounted torque convertor clutch (TCC) solenoid used for torque convertor engagement.

The powertrain control module (PCM) will determine when to engage and disengage the solenoid by monitoring vehicle miles per hour (mph) versus the output voltage of the throttle position sensor. Also needed are various inputs from:

- Transmission temperature sensor
- Output shaft speed sensor
- Module timer
- Engine rpm
- MAP sensor
- Brake switch

MANUAL TRANSMISSION

If equipped with a manual transmission, this PCM output will control operation of the shift indicator lamp (if equipped with lamp). The lamp is controlled by the powertrain control module (PCM). The lamp illuminates on the instrument panel to indicate when the driver should shift to the next highest gear for best fuel economy. The PCM will turn the lamp OFF after 3 to 5 seconds if the shift of gears is not performed. The lamp will remain off until vehicle stops accelerating and is brought back to range of up-shift lamp operation. This will also happen if vehicle is shifted into fifth gear.

The indicator lamp is normally illuminated when the ignition switch is turned on and it is turned off when the engine is started up. With the engine running, the lamp is turned ON/OFF depending upon engine speed and load.

TRANSMISSION RELAY—PCM OUTPUT

The output to this relay provides battery voltage to the overdrive (OD), torque converter clutch (TCC)

and governor pressure solenoids. Once battery voltage is applied to the solenoids, they are individually activated by the PCM through OD, TCC and governor pressure outputs. The relay is located in the Power Distribution Center (PDC). Refer to label on PDC cover for relay location.

GOVERNOR PRESSURE SOLENOID—PCM OUTPUT

This solenoid regulates the transmission fluid line pressure to produce the governor pressure necessary for transmission shift control. It is used on 4-speed electronic transmissions only.

THROTTLE BODY—5.2L/5.9L ENGINES

Filtered air from the air cleaner enters the intake manifold through the throttle body (Fig. 20). Fuel does not enter the intake manifold through the throttle body. Fuel is sprayed into the manifold by the fuel injectors. The throttle body is mounted on the intake manifold. It contains an air control passage (Fig. 21) controlled by an idle air control (IAC) motor. The air control passage is used to supply air for idle conditions. A throttle valve (plate) is used to supply air for above idle conditions.

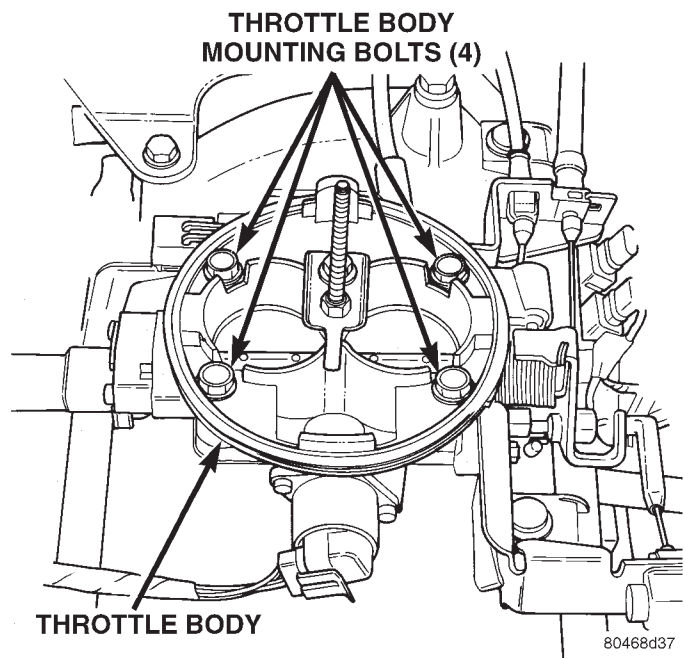


Fig. 20 Throttle Body—5.2L/5.9L Engines—Typical

The throttle position sensor (TPS), idle air control (IAC) motor and manifold absolute pressure sensor (MAP) are attached to the throttle body. The accelerator pedal cable, speed control cable and transmission control cable (when equipped) are connected to the throttle arm.

A (factory adjusted) set screw is used to mechanically limit the position of the throttle body throttle plate. **Never attempt to adjust the engine idle**

DESCRIPTION AND OPERATION (Continued)

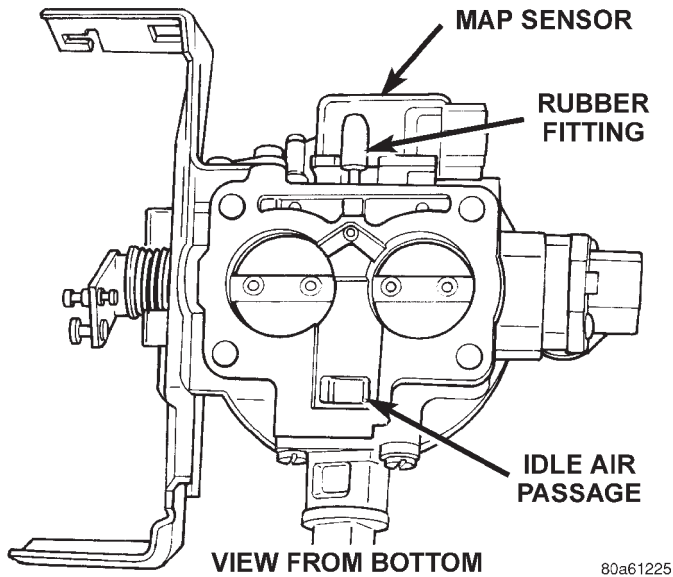


Fig. 21 Air Control Passage—5.2L/5.9L Engines—Typical

speed using this screw. All idle speed functions are controlled by the PCM.

THROTTLE BODY—4.0L ENGINE

Filtered air from the air cleaner enters the intake manifold through the throttle body (Fig. 22). Fuel does not enter the intake manifold through the throttle body. Fuel is sprayed into the manifold by the fuel injectors. The throttle body is mounted on the intake manifold. It contains an air control passage (Fig. 22) controlled by an idle air control (IAC) motor. The air control passage is used to supply air for idle conditions. A throttle valve (plate) is used to supply air for above idle conditions.

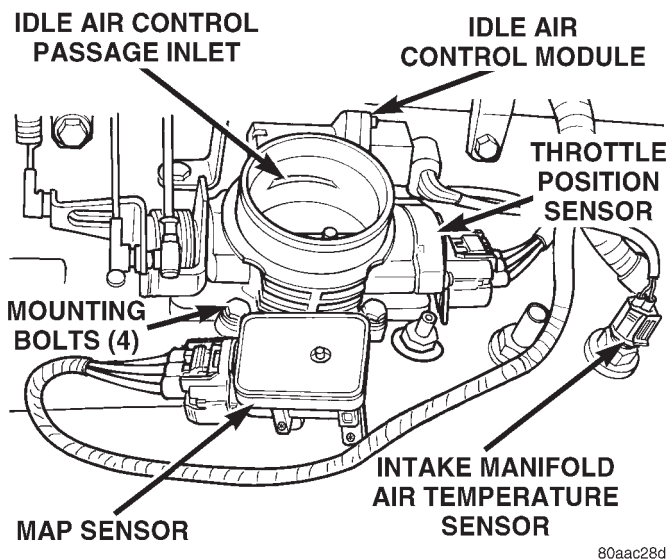


Fig. 22 Throttle Body—4.0L Engine

The throttle position sensor (TPS), idle air control (IAC) motor and manifold absolute pressure sensor (MAP) are attached to the throttle body. The accelerator pedal cable, speed control cable and transmission control cable (when equipped) are connected to the throttle arm.

A (factory adjusted) set screw is used to mechanically limit the position of the throttle body throttle plate. **Never attempt to adjust the engine idle speed using this screw.** All idle speed functions are controlled by the PCM.

DIAGNOSIS AND TESTING

VISUAL INSPECTION—5.2L/5.9L ENGINES

A visual inspection for loose, disconnected or incorrectly routed wires and hoses should be made. This should be done before attempting to diagnose or service the fuel injection system. A visual check will help spot these faults and save unnecessary test and diagnostic time. A thorough visual inspection will include the following checks:

(1) Verify that the three 32-way electrical connectors are fully inserted into the connector of the powertrain control module (PCM) (Fig. 23).

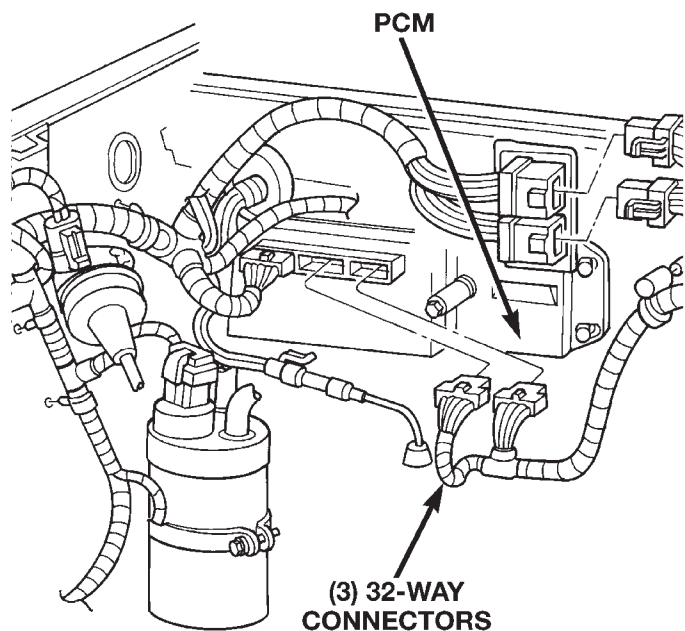


Fig. 23 Powertrain Control Module (PCM)

(2) Inspect the battery cable connections. Be sure that they are clean and tight.

(3) Inspect fuel pump relay and air conditioning compressor clutch relay (if equipped). Inspect the ASD relay connections. Inspect starter motor relay connections. Inspect relays for signs of physical damage and corrosion. The relays are located in the

DIAGNOSIS AND TESTING (Continued)

Power Distribution Center (PDC) (Fig. 24). Refer to label on PDC cover for relay location.

(4) Inspect ignition coil connections. Verify that coil secondary cable is firmly connected to coil (Fig. 25).

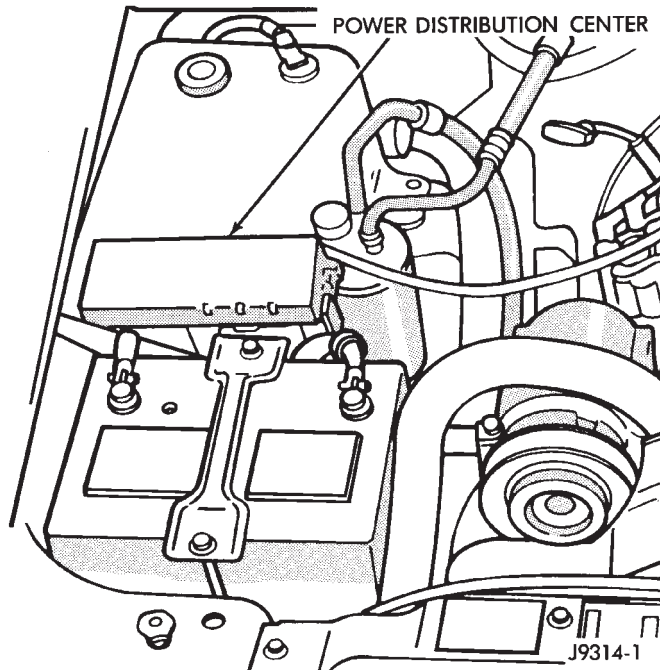


Fig. 24 Power Distribution Center (PDC)

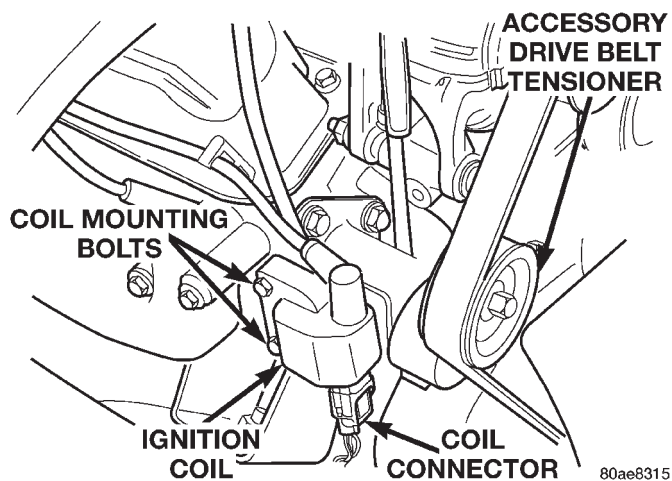


Fig. 25 Ignition Coil—5.2L/5.9L Engines

(5) Verify that distributor cap is correctly attached to distributor. Be sure that spark plug cables are firmly connected to the distributor cap and the spark plugs are in their correct firing order. Be sure that coil cable is firmly connected to distributor cap and coil. Be sure that camshaft position sensor wire connector (at the distributor) is firmly connected to harness connector. Inspect spark plug condition. Refer to Group 8D, Ignition. Connect vehicle to an oscilloscope

and inspect spark events for fouled or damaged spark plugs or cables.

(6) Verify that generator output wire, generator connector and ground wire are firmly connected to the generator.

(7) Inspect the system body grounds for loose or dirty connections. Refer to Group 8, Wiring for ground locations.

(8) Verify positive crankcase ventilation (PCV) valve operation. Refer to Group 25, Emission Control System for additional information. Verify PCV valve hose is firmly connected to PCV valve and manifold (Fig. 26).

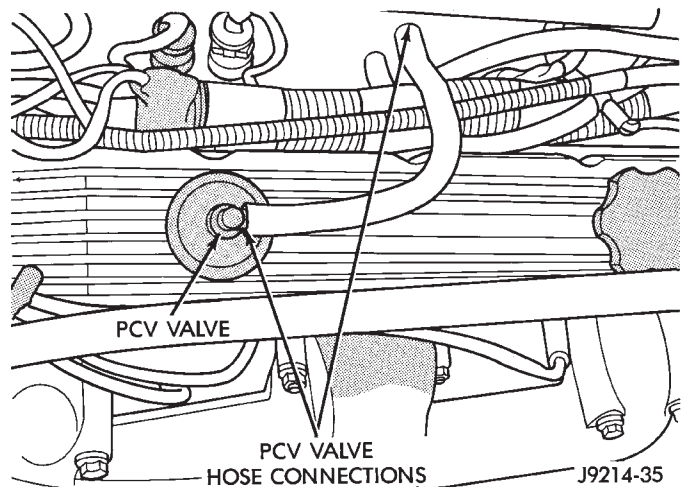


Fig. 26 PCV Valve Hose Connections—5.2L/5.9L Engines—Typical

(9) Inspect fuel tube quick-connect fitting-to-fuel rail connections.

(10) Verify that hose connections to all ports of vacuum fittings on intake manifold are tight and not leaking.

(11) Inspect accelerator cable, transmission throttle cable (if equipped) and cruise control cable connections (if equipped). Check their connections to the throttle arm of throttle body for any binding or restrictions.

(12) If equipped with vacuum brake booster, verify that vacuum booster hose is firmly connected to fitting on intake manifold. Also check connection to brake vacuum booster.

(13) Inspect the air cleaner inlet and air cleaner element for dirt or restrictions.

(14) Inspect radiator grille area, radiator fins and air conditioning condenser for restrictions.

(15) Verify that the intake manifold air temperature sensor wire connector is firmly connected to harness connector (Fig. 27).

(16) Verify that MAP sensor electrical connector is firmly connected to MAP sensor (Fig. 28). Also verify

DIAGNOSIS AND TESTING (Continued)

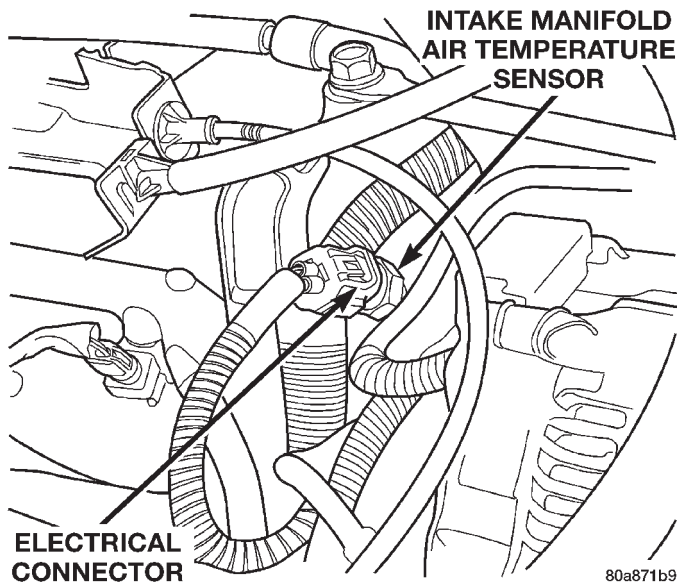


Fig. 27 Air Temperature Sensor—5.2L/5.9L Engines

that rubber L-shaped fitting from MAP sensor to the throttle body is firmly connected (Fig. 29).

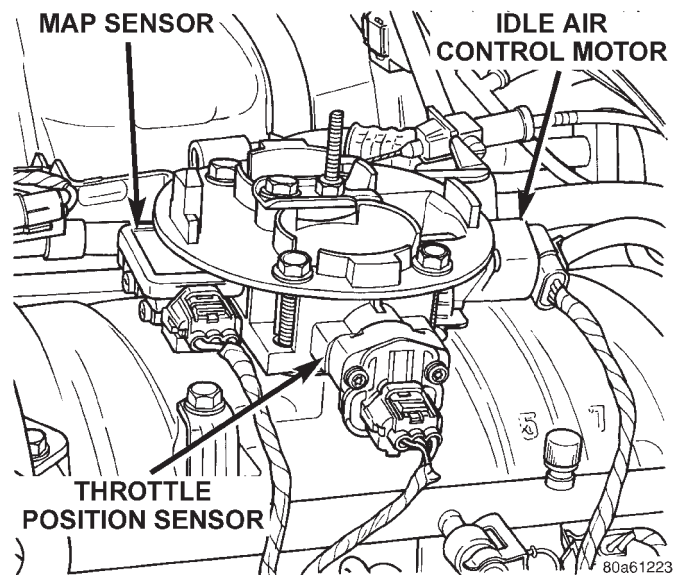


Fig. 28 Sensor and IAC Motor Location—5.2L/5.9L Engines

(17) Verify that fuel injector wire harness connectors are firmly connected to injectors in the correct order. Each harness connector is numerically tagged with the injector number (INJ 1, INJ 2 etc.) of its corresponding fuel injector and cylinder number.

(18) Verify harness connectors are firmly connected to idle air control (IAC) motor, throttle position sensor (TPS) and manifold absolute pressure (MAP) sensor (Fig. 28).

(19) Verify that wire harness connector is firmly connected to the engine coolant temperature sensor (Fig. 30).

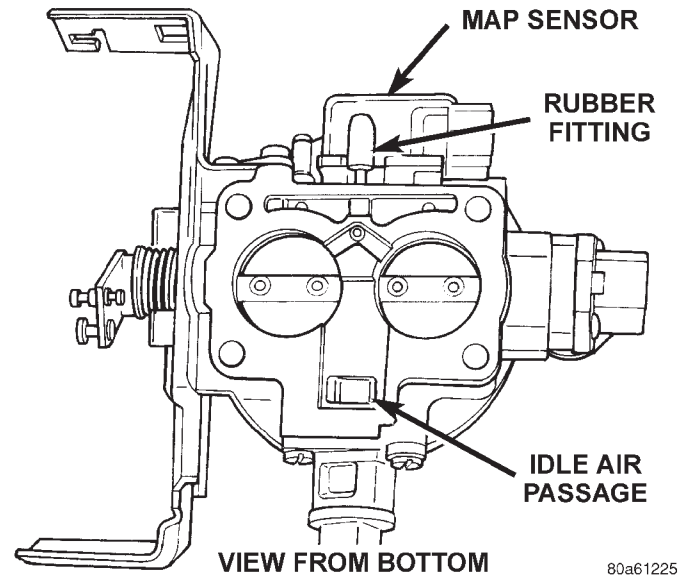


Fig. 29 Rubber L-Shaped Fitting—MAP Sensor-to-Throttle Body

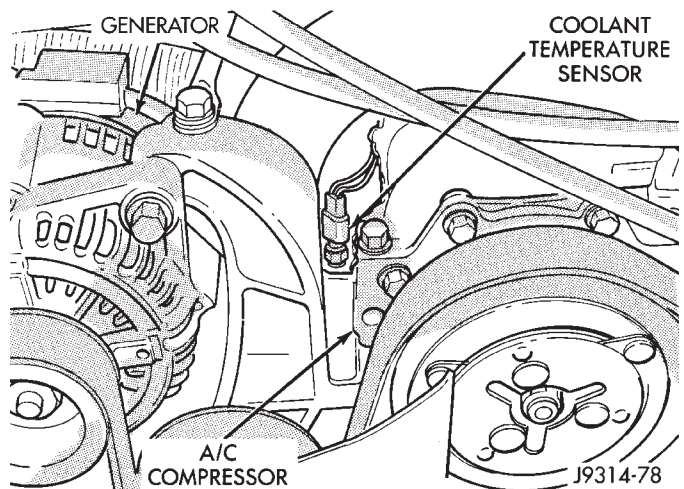


Fig. 30 Engine Coolant Temperature Sensor—5.2L/5.9L Engines—Typical

(20) Raise and support the vehicle.

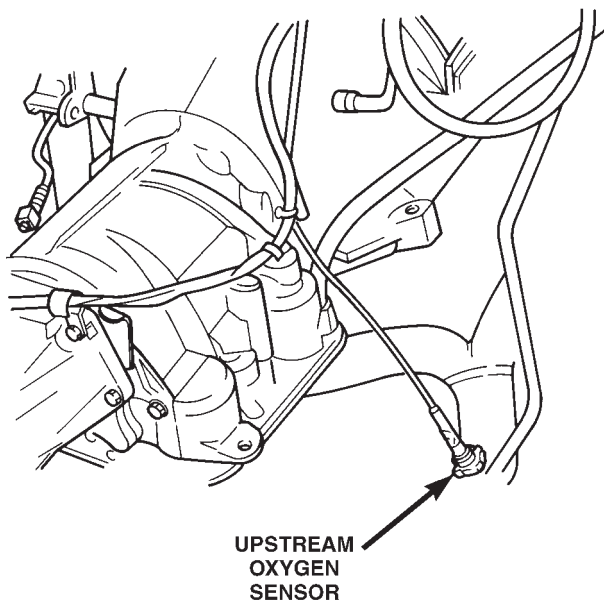
(21) Verify that both the upstream and downstream oxygen sensor wire connectors are firmly connected to the sensors. Inspect sensors and connectors for damage (Fig. 31) or (Fig. 32).

(22) Inspect for pinched or leaking fuel tubes. Inspect for pinched, cracked or leaking fuel hoses.

(23) Inspect for exhaust system restrictions such as pinched exhaust pipes, collapsed muffler or plugged catalytic convertor.

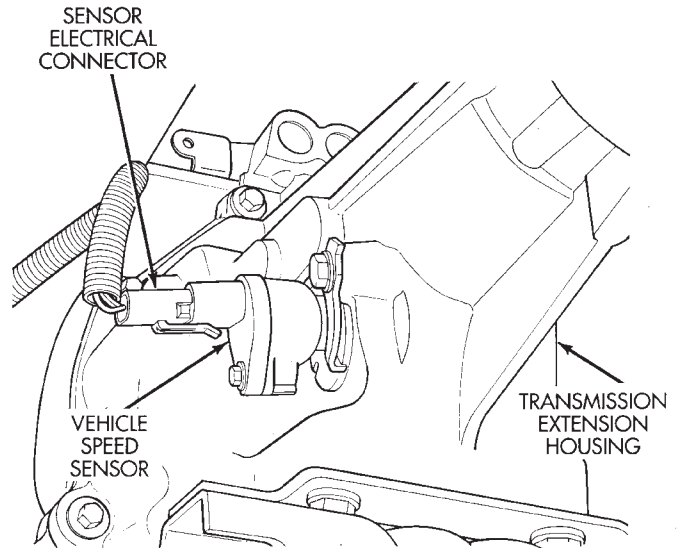
(24) If equipped with automatic transmission, verify that electrical harness is firmly connected to park/neutral switch. Refer to Automatic Transmission section of Group 21.

DIAGNOSIS AND TESTING (Continued)



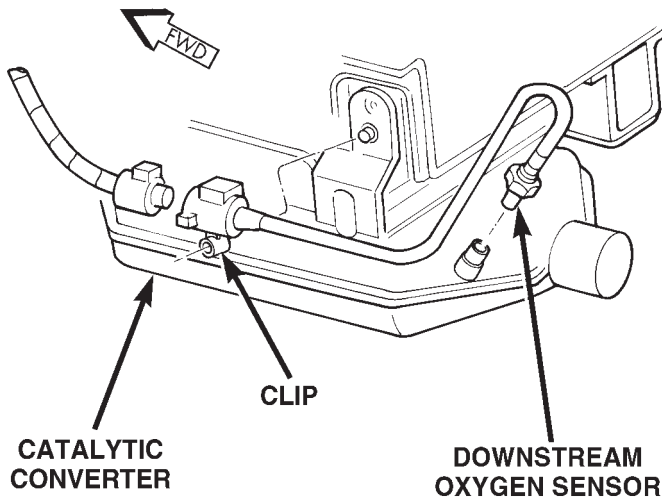
80a01307

Fig. 31 Upstream Oxygen Sensor—5.2L/5.9L Engines



J9414-60

Fig. 33 Vehicle Speed Sensor—2WD—Typical



80a6f169

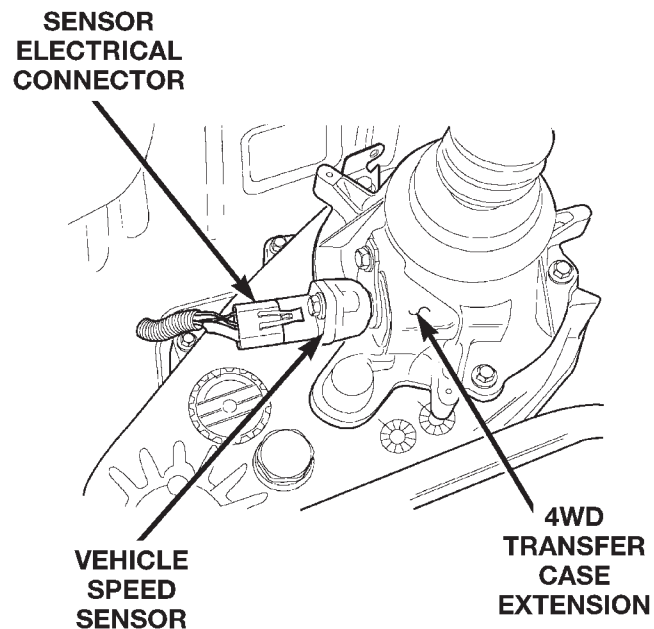
Fig. 32 Downstream Oxygen Sensor—5.2L/5.9L Engines

(25) Verify that the electrical harness connector is firmly connected to the vehicle speed sensor (Fig. 33) or (Fig. 34).

(26) Verify that fuel pump/gauge sender unit wire connector is firmly connected to harness connector.

(27) Inspect fuel hoses at fuel pump/gauge sender unit for cracks or leaks.

(28) Inspect transmission torque convertor housing (automatic transmission) or clutch housing (manual transmission) for damage to timing ring on drive plate/flywheel.



80a35409

Fig. 34 Vehicle Speed Sensor—4WD—Typical

(29) Verify that battery cable and solenoid feed wire connections to the starter solenoid are tight and clean. Inspect for chafed wires or wires rubbing up against other components.

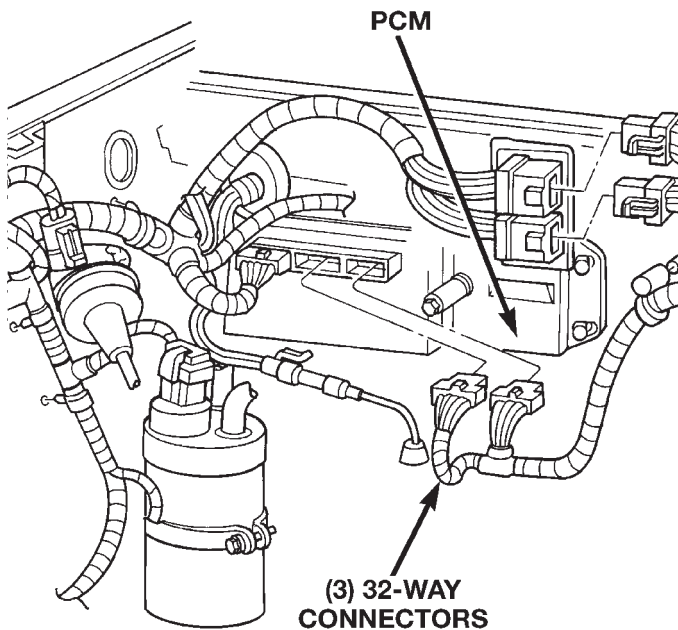
VISUAL INSPECTION—4.0L ENGINE

A visual inspection for loose, disconnected or incorrectly routed wires and hoses should be made. This should be done before attempting to diagnose or service the fuel injection system. A visual check will

DIAGNOSIS AND TESTING (Continued)

help spot these faults and save unnecessary test and diagnostic time. A thorough visual inspection will include the following checks:

(1) Verify that the three 32-way electrical connectors are fully inserted into the connector of the powertrain control module (PCM) (Fig. 35).



80a01300

Fig. 35 Powertrain Control Module (PCM)

(2) Inspect the battery cable connections. Be sure that they are clean and tight.

(3) Inspect fuel pump relay and air conditioning compressor clutch relay (if equipped). Inspect the ASD relay connections. Inspect starter motor relay connections. Inspect relays for signs of physical damage and corrosion. The relays are located in the Power Distribution Center (PDC) (Fig. 36). Refer to label on PDC cover for relay location.

(4) Inspect ignition coil connections. Verify that coil secondary cable is firmly connected to coil (Fig. 37).

(5) Verify that distributor cap is correctly attached to distributor. Be sure that spark plug cables are firmly connected to the distributor cap and the spark plugs are in their correct firing order. Be sure that coil cable is firmly connected to distributor cap and coil. Be sure that camshaft position sensor wire connector (at the distributor) is firmly connected to harness connector. Inspect spark plug condition. Refer to Group 8D, Ignition. Connect vehicle to an oscilloscope and inspect spark events for fouled or damaged spark plugs or cables.

(6) Verify that generator output wire, generator connector and ground wire are firmly connected to the generator.

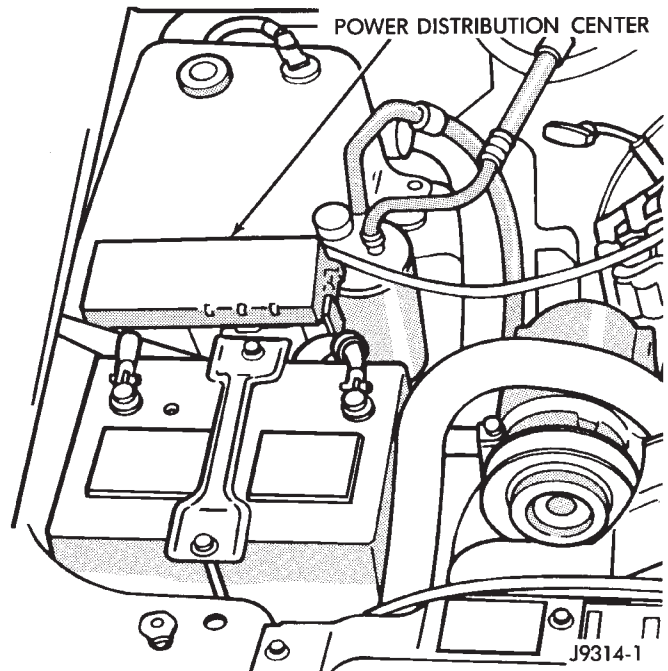
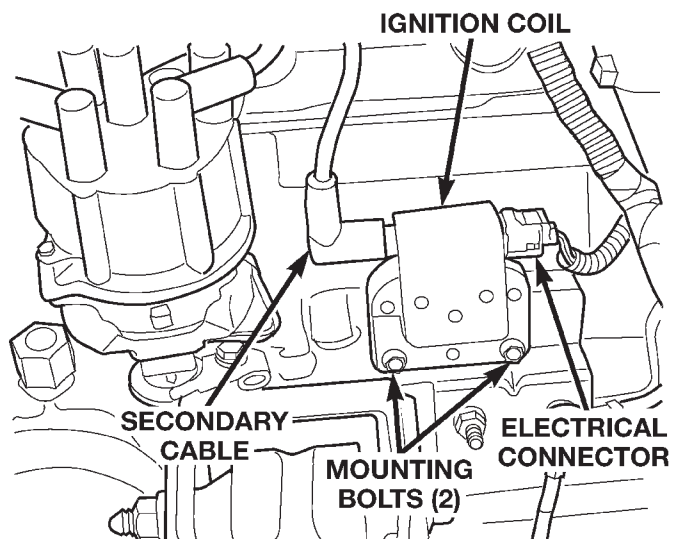


Fig. 36 Power Distribution Center (PDC)



80ae8319

Fig. 37 Ignition Coil—4.0L Engine

(7) Inspect the system body grounds for loose or dirty connections. Refer to Group 8, Wiring for ground locations.

(8) Verify crankcase ventilation (CCV) operation. Refer to Group 25, Emission Control System for additional information.

(9) Inspect fuel tube quick-connect fitting-to-fuel rail connections.

(10) Verify that hose connections to all ports of vacuum fittings on intake manifold are tight and not leaking.

(11) Inspect accelerator cable, transmission throttle cable (if equipped) and cruise control cable con-

DIAGNOSIS AND TESTING (Continued)

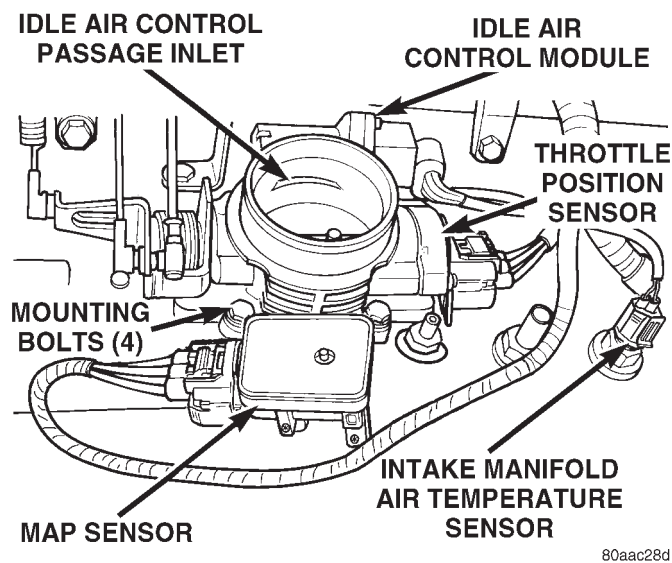
nections (if equipped). Check their connections to the throttle arm of throttle body for any binding or restrictions.

(12) If equipped with vacuum brake booster, verify that vacuum booster hose is firmly connected to fitting on intake manifold. Also check connection to brake vacuum booster.

(13) Inspect the air cleaner inlet and air cleaner element for dirt or restrictions.

(14) Inspect radiator grille area, radiator fins and air conditioning condenser for restrictions.

(15) Verify that the intake manifold air temperature sensor wire connector is firmly connected to harness connector (Fig. 38).



80aac28d

Fig. 38 Sensor Locations—4.0L Engine

(16) Verify that MAP sensor electrical connector is firmly connected to MAP sensor (Fig. 38). Also verify that rubber L-shaped fitting from MAP sensor to the throttle body is firmly connected (Fig. 39).

(17) Verify that fuel injector wire harness connectors are firmly connected to injectors in the correct order. Each harness connector is numerically tagged with the injector number (INJ 1, INJ 2 etc.) of its corresponding fuel injector and cylinder number.

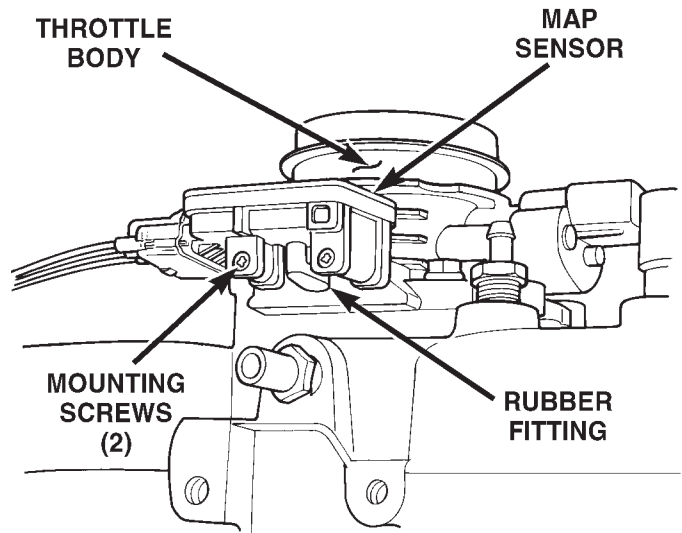
(18) Verify harness connectors are firmly connected to idle air control (IAC) motor and throttle position sensor (TPS) (Fig. 38).

(19) Verify that wire harness connector is firmly connected to the engine coolant temperature sensor (Fig. 40).

(20) Raise and support the vehicle.

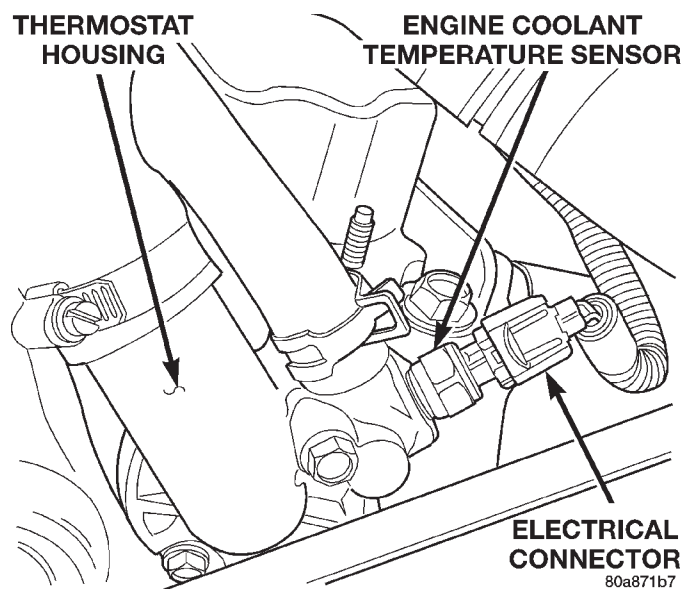
(21) Verify that both of the oxygen sensor wire connectors are firmly connected to the sensors. Inspect sensors and connectors for damage (Fig. 41) or (Fig. 42).

(22) Inspect for pinched or leaking fuel tubes. Inspect for pinched, cracked or leaking fuel hoses.



80a6f168

Fig. 39 Rubber L-Shaped Fitting—MAP Sensor-to-Throttle Body



80a871b7

Fig. 40 Engine Coolant Temp. Sensor—4.0L Shown

(23) Inspect for exhaust system restrictions such as pinched exhaust pipes, collapsed muffler or plugged catalytic convertor.

(24) If equipped with automatic transmission, verify that electrical harness is firmly connected to park/neutral switch. Refer to Automatic Transmission section of Group 21.

(25) Verify that the electrical harness connector is firmly connected to the vehicle speed sensor (Fig. 43) or (Fig. 44).

(26) Verify that fuel pump/gauge sender unit wire connector is firmly connected to harness connector.

(27) Inspect fuel hoses at fuel pump/gauge sender unit for cracks or leaks.

DIAGNOSIS AND TESTING (Continued)

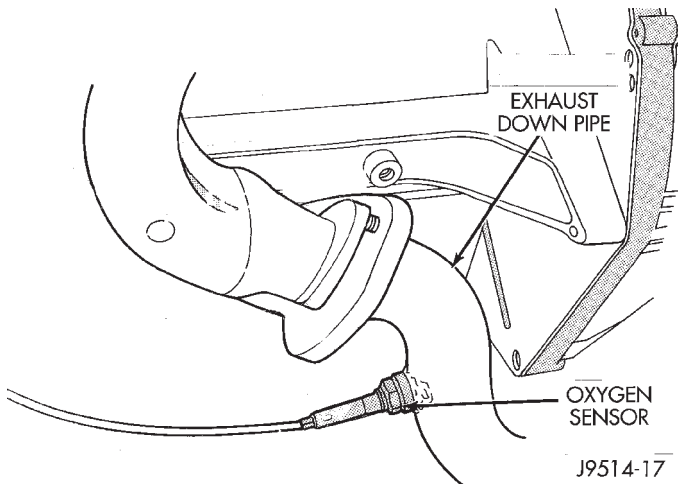


Fig. 41 Upstream Oxygen Sensor—4.0L Engine

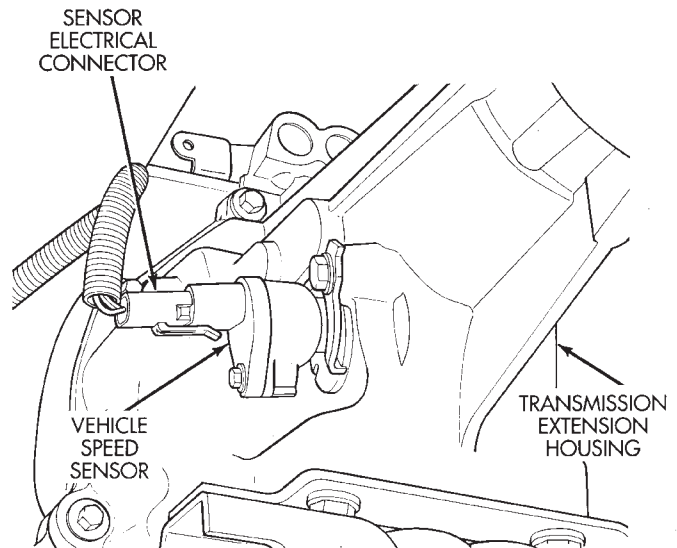


Fig. 43 Vehicle Speed Sensor—2WD—Typical

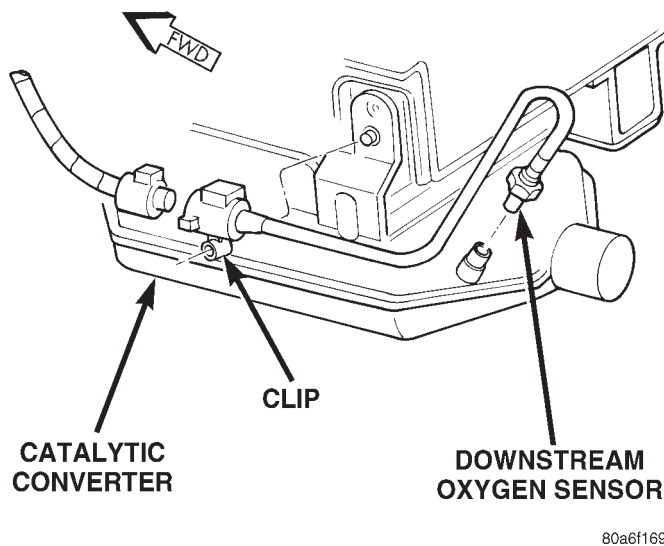


Fig. 42 Downstream Oxygen Sensor—4.0L Engine

(28) Inspect transmission torque converter housing (automatic transmission) or clutch housing (manual transmission) for damage to timing ring on drive plate/flywheel.

(29) Verify that battery cable and solenoid feed wire connections to the starter solenoid are tight and clean. Inspect for chaffed wires or wires rubbing up against other components.

ASD AND FUEL PUMP RELAYS

The following description of operation and tests apply only to the Automatic Shutdown (ASD) and fuel pump relays. The terminals on the bottom of each relay are numbered (Fig. 45) or (Fig. 46).

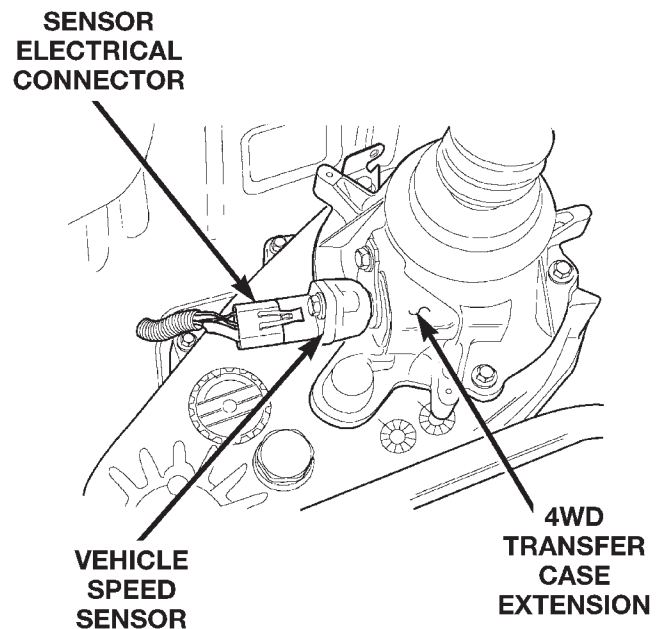


Fig. 44 Vehicle Speed Sensor—4WD—Typical

OPERATION

- Terminal number 30 is connected to battery voltage. For both the ASD and fuel pump relays, terminal 30 is connected to battery voltage at all times.
- The PCM grounds the coil side of the relay through terminal number 85.
- Terminal number 86 supplies voltage to the coil side of the relay.
- When the PCM de-energizes the ASD and fuel pump relays, terminal number 87A connects to termi-

DIAGNOSIS AND TESTING (Continued)

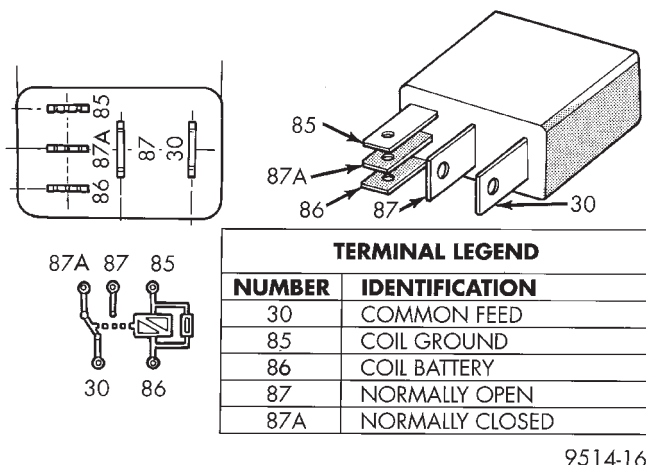


Fig. 45 ASD and Fuel Pump Relay Terminals

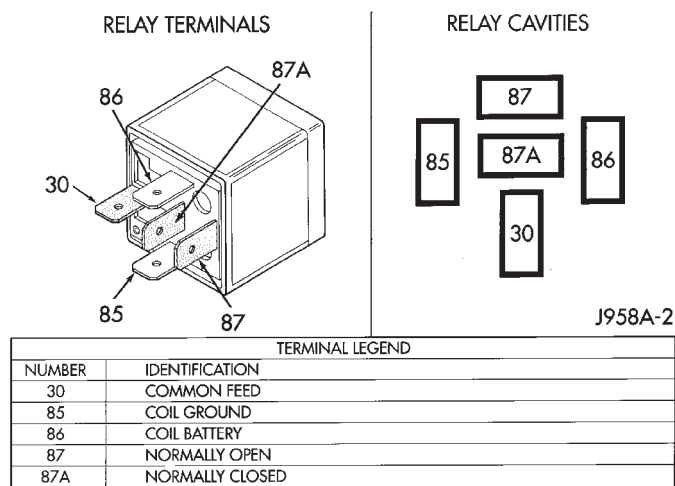


Fig. 46 ASD and Fuel Pump Relay Terminals

nal 30. This is the Off position. In the off position, voltage is not supplied to the rest of the circuit. Terminal 87A is the center terminal on the relay.

- When the PCM energizes the ASD and fuel pump relays, terminal 87 connects to terminal 30. This is the On position. Terminal 87 supplies voltage to the rest of the circuit.

TESTING

The following procedure applies to the ASD and fuel pump relays.

- (1) Remove relay from connector before testing.
- (2) With the relay removed from the vehicle, use an ohmmeter to check the resistance between terminals 85 and 86. The resistance should be between 75 ±5 ohms.
- (3) Connect the ohmmeter between terminals 30 and 87A. The ohmmeter should show continuity between terminals 30 and 87A.
- (4) Connect the ohmmeter between terminals 87 and 30. The ohmmeter should not show continuity at this time.

(5) Connect one end of a jumper wire (16 gauge or smaller) to relay terminal 85. Connect the other end of the jumper wire to the ground side of a 12 volt power source.

(6) Connect one end of another jumper wire (16 gauge or smaller) to the power side of the 12 volt power source. **Do not attach the other end of the jumper wire to the relay at this time.**

WARNING: DO NOT ALLOW OHMMETER TO CONTACT TERMINALS 85 OR 86 DURING THIS TEST.

(7) Attach the other end of the jumper wire to relay terminal 86. This activates the relay. The ohmmeter should now show continuity between relay terminals 87 and 30. The ohmmeter should not show continuity between relay terminals 87A and 30.

(8) Disconnect jumper wires.

(9) Replace the relay if it did not pass the continuity and resistance tests. If the relay passed the tests, it operates properly. Check the remainder of the ASD and fuel pump relay circuits. Refer to group 8W, Wiring Diagrams.

MANIFOLD ABSOLUTE PRESSURE (MAP) SENSOR TEST—5.2L/5.9L ENGINES

To perform a complete test of MAP sensor (Fig. 47) and its circuitry, refer to DRB scan tool and appropriate Powertrain Diagnostics Procedures manual. To test the MAP sensor only, refer to the following:

(1) Inspect the rubber L-shaped fitting from the MAP sensor to the throttle body (Fig. 48). Repair as necessary.

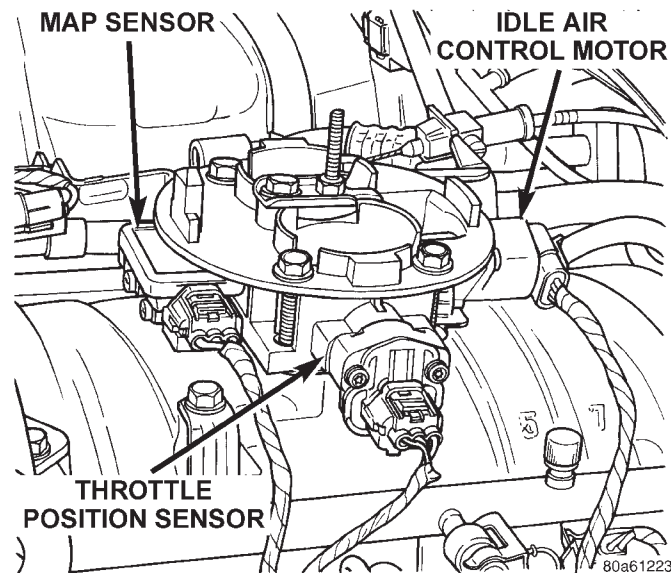


Fig. 47 MAP Sensor—5.2L/5.9L Engines—Typical

CAUTION: When testing the MAP sensor, be sure that the harness wires are not damaged by the test meter probes.

DIAGNOSIS AND TESTING (Continued)

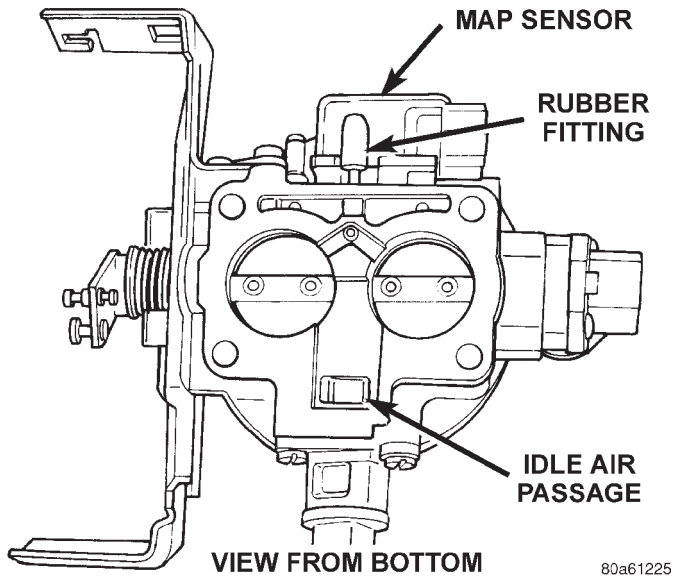


Fig. 48 Rubber L-Shaped Fitting—MAP Sensor-to-Throttle Body

(2) Test the MAP sensor output voltage at the MAP sensor connector between terminals A and B (Fig. 49). With the ignition switch ON and the engine OFF, output voltage should be 4-to-5 volts. The voltage should drop to 1.5-to-2.1 volts with a hot, neutral idle speed condition.

A = GROUND
B = OUTPUT VOLTAGE SIGNAL
C = 5-VOLT SUPPLY

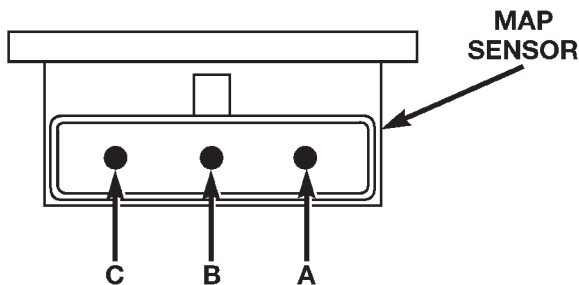


Fig. 49 MAP Sensor Connector Terminals—Typical

(3) Test powertrain control module (PCM) cavity A-27 for the same voltage described above to verify the wire harness condition. Repair as necessary.

(4) Test MAP sensor supply voltage at sensor connector between terminals A and C (Fig. 49) with the ignition ON. The voltage should be approximately 5 volts ($\pm 0.5V$). Five volts ($\pm 0.5V$) should also be at cavity A-17 of the PCM wire harness connector. Repair or replace the wire harness as necessary.

(5) Test the MAP sensor ground circuit at sensor connector terminal—A (Fig. 49) and PCM connector A-4. Repair the wire harness if necessary.

Refer to Group 8W, Wiring Diagrams for cavity locations.

MANIFOLD ABSOLUTE PRESSURE (MAP) SENSOR TEST—4.0L ENGINE

To perform a complete test of MAP sensor (Fig. 50) and its circuitry, refer to DRB scan tool and appropriate Powertrain Diagnostics Procedures manual. To test the MAP sensor only, refer to the following:

(1) Inspect the rubber L-shaped fitting from the MAP sensor to the throttle body (Fig. 51). Repair as necessary.

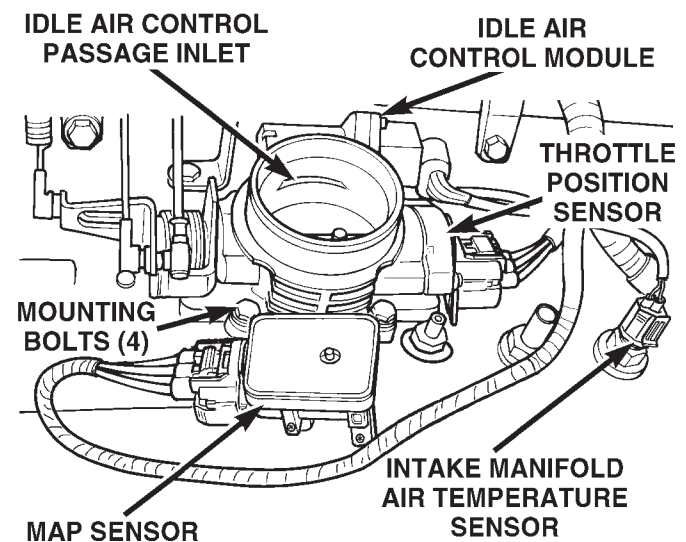


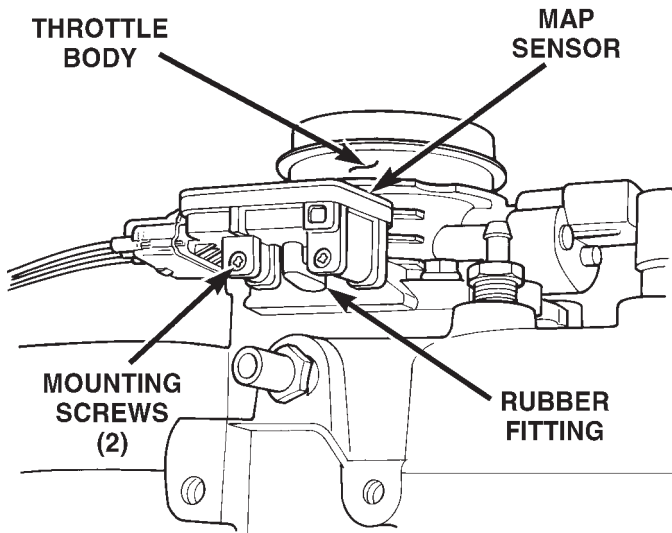
Fig. 50 Sensor Location—4.0L Engine

CAUTION: When testing the MAP sensor, be sure that the harness wires are not damaged by the test meter probes.

(2) Test the MAP sensor output voltage at the MAP sensor connector between terminals A and B (Fig. 49). With the ignition switch ON and the engine OFF, output voltage should be 4-to-5 volts. The voltage should drop to 1.5-to-2.1 volts with a hot, neutral idle speed condition.

(3) Test powertrain control module (PCM) cavity A-27 for the same voltage described above to verify the wire harness condition. Repair as necessary.

(4) Test MAP sensor supply voltage at sensor connector between terminals A and C (Fig. 49) with the ignition ON. The voltage should be approximately 5 volts ($\pm 0.5V$). Five volts ($\pm 0.5V$) should also be at cavity A-17 of the PCM wire harness connector. Repair or replace the wire harness as necessary.

DIAGNOSIS AND TESTING (Continued)

80a6f168

Fig. 51 Rubber L-Shaped Fitting—MAP Sensor-to-Throttle Body

(5) Test the MAP sensor ground circuit at sensor connector terminal—A (Fig. 49) and PCM connector A-4. Repair the wire harness if necessary.

Refer to Group 8W, Wiring Diagrams for cavity locations.

OXYGEN (O₂S) SENSORS—5.2L/5.9L ENGINES

To perform a complete test of the O₂S sensors and their circuitry, refer to the DRB scan tool and appropriate Powertrain Diagnostics Procedures manual. To test the O₂S sensors only, refer to the following:

The upstream O₂S sensor is located on the exhaust pipe (Fig. 52).

The downstream O₂S sensor is located on the outlet end of the catalytic converter (Fig. 53).

Each O₂S heating element can be tested with an ohmmeter as follows:

Disconnect the O₂S sensor connector. Connect the ohmmeter test leads across the white wire terminals of the sensor connector. Resistance should be between $4.5 \pm .5$ ohms and 7 ohms. Replace the sensor if the ohmmeter displays an infinity (open) reading.

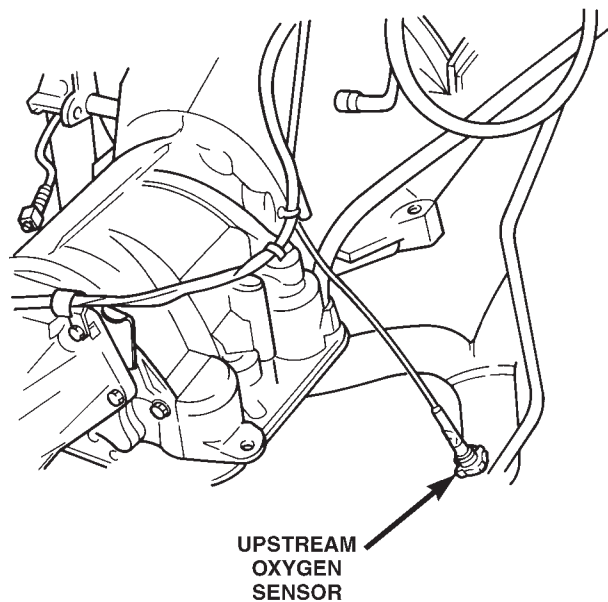
OXYGEN (O₂S) SENSORS—4.0L ENGINE

To perform a complete test of the O₂S sensors and their circuitry, refer to the DRB scan tool and appropriate Powertrain Diagnostics Procedures manual. To test the O₂S sensors only, refer to the following:

The upstream O₂S sensor is located on the exhaust pipe (Fig. 54).

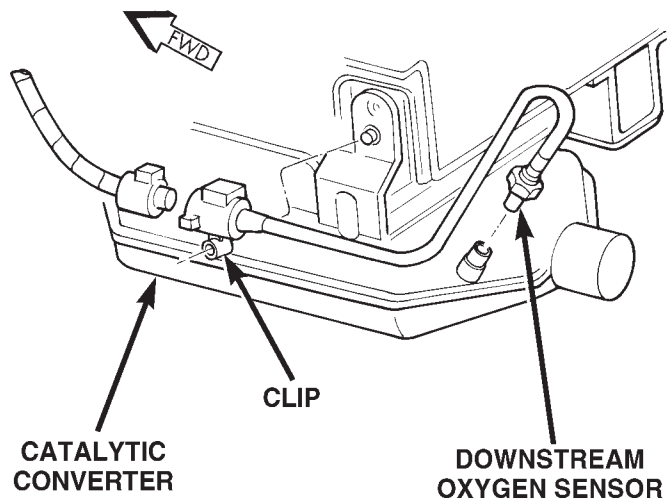
The downstream O₂S sensor is located on the outlet end of the catalytic converter (Fig. 53).

Each O₂S heating element can be tested with an ohmmeter as follows:



80a01307

Fig. 52 Upstream Oxygen Sensor Location—5.2L/5.9L Engines



80a6f169

Fig. 53 Downstream Oxygen Sensor Location—All Engines

Disconnect the O₂S sensor connector. Connect the ohmmeter test leads across the white wire terminals of the sensor connector. Resistance should be between $4.5 \pm .5$ ohms and 7 ohms. Replace the sensor if the ohmmeter displays an infinity (open) reading.

DIAGNOSIS AND TESTING (Continued)

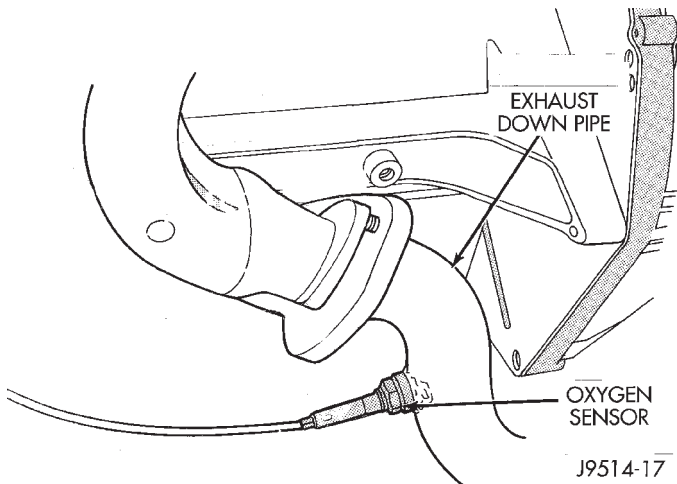


Fig. 54 Upstream Oxygen Sensor Location—4.0L Engine

CAMSHAFT AND CRANKSHAFT POSITION SENSORS

Refer to Group 8D, Ignition System for information.

ENGINE COOLANT TEMPERATURE SENSOR—5.2L/5.9L ENGINES

To perform a complete test of the engine coolant temperature sensor and its circuitry, refer to DRB scan tool and appropriate Powertrain Diagnostics Procedures manual. To test the sensor only, refer to the following:

(1) Disconnect wire harness connector from coolant temperature sensor (Fig. 55).

(2) **Engines with air conditioning:** When removing the connector from sensor, do not pull directly on wiring harness. Fabricate an L-shaped hook tool from a coat hanger (approximately eight inches long). Place the hook part of tool under the connector for removal. The connector is snapped onto the sensor. It is not equipped with a lock type tab.

(3) Test the resistance of sensor with a high input impedance (digital) volt-ohmmeter. Refer to SENSOR RESISTANCE (OHMS)—COOLANT TEMPERATURE SENSOR/INTAKE AIR TEMPERATURE SENSOR chart. The resistance (as measured across sensor terminals) should be within range shown in chart. If not, replace sensor.

(4) Test continuity of the wire harness between the PCM wire harness connector and the coolant sensor connector terminals. Refer to Group 8, Wiring for terminal/cavity locations. Repair the wire harness if an open circuit is indicated.

(5) After tests are completed, connect electrical connector to sensor. The sensor connector is symmetrical (not indexed). It can be installed to the sensor in either direction.

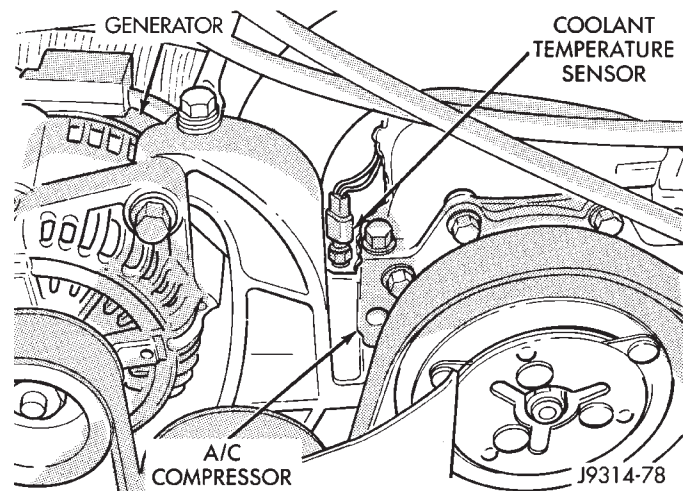


Fig. 55 Engine Coolant Temperature Sensor—5.2L/5.9L Engines

SENSOR RESISTANCE (OHMS)—COOLANT TEMPERATURE SENSOR/INTAKE AIR TEMPERATURE SENSOR

TEMPERATURE		RESISTANCE (OHMS)	
°CEL.	°FAHR.	MIN.	MAX.
-40	-40	291,490	381,710
-20	-4	85,850	108,390
-10	14	49,250	61,430
0	32	29,330	35,990
10	50	17,990	21,810
20	68	11,370	13,610
25	77	9,120	10,880
30	86	7,370	8,750
40	104	4,900	5,750
50	122	3,330	3,880
60	140	2,310	2,670
70	158	1,630	1,870
80	176	1,170	1,340
90	194	860	970
100	212	640	720
110	230	480	540
120	248	370	410

ENGINE COOLANT TEMPERATURE SENSOR—4.0L ENGINE

To perform a complete test of the engine coolant temperature sensor and its circuitry, refer to DRB scan tool and appropriate Powertrain Diagnostics Procedures manual. To test the sensor only, refer to the following:

(1) Disconnect wire harness connector from coolant temperature sensor (Fig. 56).

(2) Test the resistance of sensor with a high input impedance (digital) volt-ohmmeter. Refer to SENSOR RESISTANCE (OHMS)—COOLANT TEMPERA-

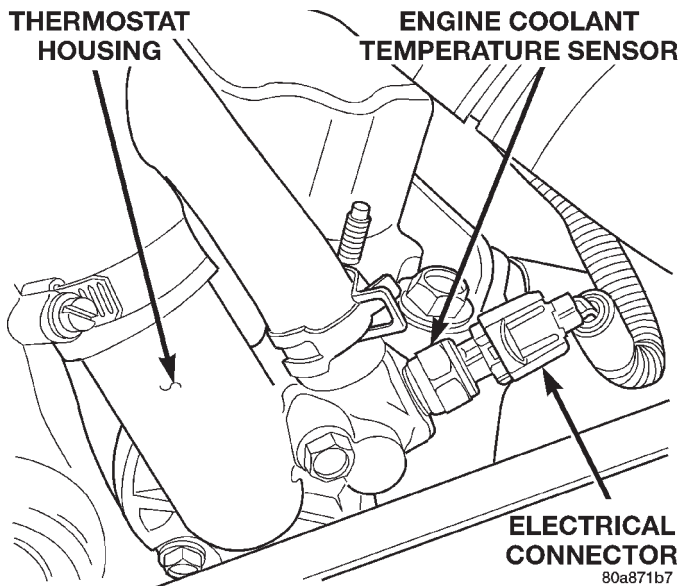
DIAGNOSIS AND TESTING (Continued)

Fig. 56 Engine Coolant Temperature Sensor—4.0L Engine

ATURE SENSOR/INTAKE AIR TEMPERATURE SENSOR chart. The resistance (as measured across sensor terminals) should be within range shown in chart. If not, replace sensor.

(3) Test continuity of the wire harness between the PCM wire harness connector and the coolant sensor connector terminals. Refer to Group 8, Wiring for terminal/cavity locations. Repair the wire harness if an open circuit is indicated.

IDLE AIR CONTROL (IAC) MOTOR— 5.2L/5.9L ENGINES

To perform a complete test of the IAC motor and its circuitry, refer to DRB scan tool and appropriate Powertrain Diagnostics Procedures manual.

IDLE AIR CONTROL (IAC) MOTOR—4.0L ENGINE

To perform a complete test of the IAC motor and its circuitry, refer to DRB scan tool and appropriate Powertrain Diagnostics Procedures manual.

INTAKE MANIFOLD AIR TEMPERATURE SENSOR— 5.2L/5.9L ENGINE

To perform a complete test of the intake manifold air temperature sensor and its circuitry, refer to DRB tester and appropriate Powertrain Diagnostics Procedures manual. To test the sensor only, refer to the following:

(1) Disconnect the wire harness connector from the intake manifold air temperature sensor (Fig. 57).

(2) Test the resistance of sensor with a high input impedance (digital) volt-ohmmeter. Refer to SENSOR RESISTANCE (OHMS)—COOLANT TEMPERATURE SENSOR/INTAKE AIR TEMPERATURE SENSOR chart. The resistance (as measured across

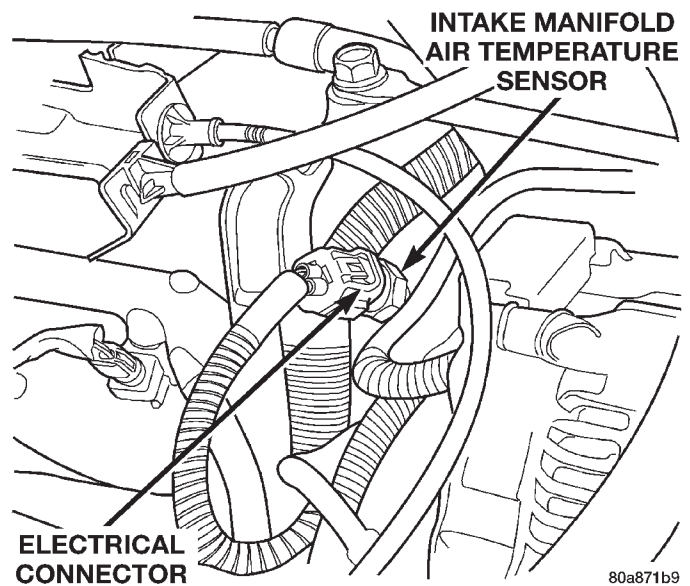


Fig. 57 Air Temperature Sensor—5.2L/5.9L Engines

sensor terminals) should be within range shown in chart. If not, replace sensor.

(3) Test the resistance of the wire harness. Do this between the PCM wire harness connector A-15 and the sensor connector terminal. Also check between PCM connector A-4 to the sensor connector terminal. Repair the wire harness as necessary if the resistance is greater than 1 ohm.

INTAKE MANIFOLD AIR TEMPERATURE SENSOR— 4.0L ENGINE

To perform a complete test of the intake manifold air temperature sensor and its circuitry, refer to DRB tester and appropriate Powertrain Diagnostics Procedures manual. To test the sensor only, refer to the following:

(1) Disconnect the wire harness connector from the intake manifold air temperature sensor (Fig. 58).

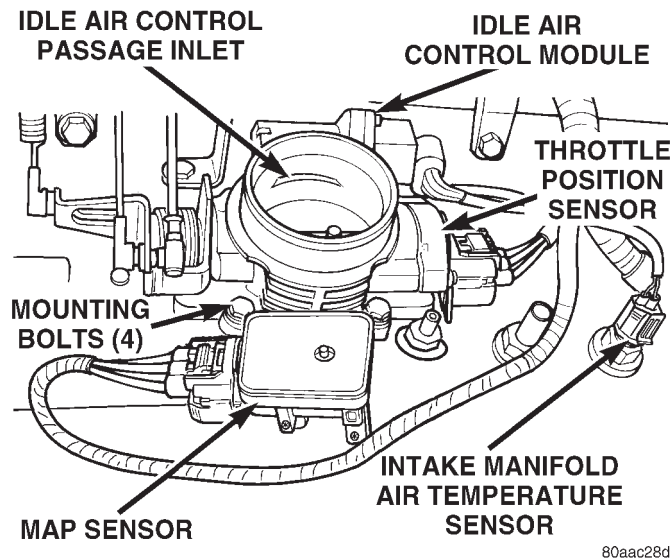
(2) Test the resistance of sensor with a high input impedance (digital) volt-ohmmeter. Refer to SENSOR RESISTANCE (OHMS)—COOLANT TEMPERATURE SENSOR/INTAKE AIR TEMPERATURE SENSOR chart. The resistance (as measured across sensor terminals) should be within range shown in chart. If not, replace sensor.

(3) Test the resistance of the wire harness. Do this between the PCM wire harness connector A-15 and the sensor connector terminal. Also check between PCM connector A-4 to the sensor connector terminal. Repair the wire harness as necessary if the resistance is greater than 1 ohm.

VEHICLE SPEED SENSOR

To perform a complete test of the sensor and its circuitry, refer to DRB scan tool and appropriate Powertrain Diagnostics Procedures manual.

DIAGNOSIS AND TESTING (Continued)



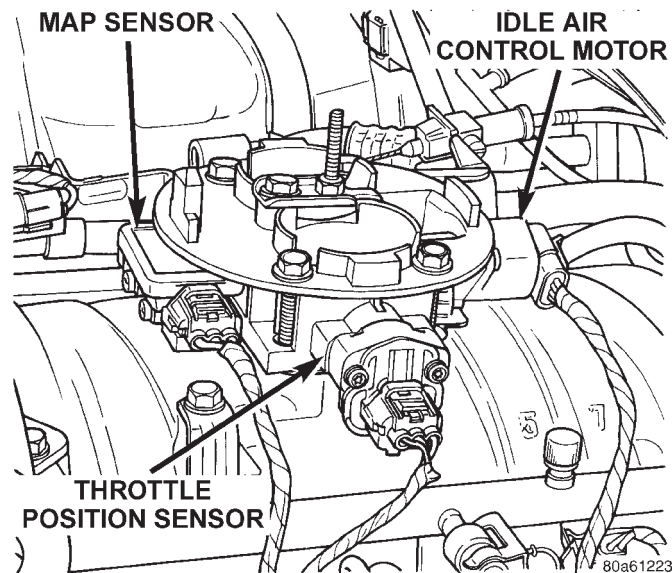
80aac28d

Fig. 58 Intake Manifold Air Temperature Sensor—4.0L Engine

THROTTLE POSITION SENSOR (TPS)—5.2L/5.9L ENGINES

To perform a complete test of the TPS and its circuitry, refer to the DRB scan tool and appropriate Powertrain Diagnostics Procedures manual. To test the TPS only, refer to the following:

The TPS (Fig. 59) can be tested with a digital voltmeter. The center electrical terminal of the TPS is the output terminal.



80a61223

Fig. 59 TPS—5.2L/5.9L Engines

With the ignition key in the ON position, check the TPS output voltage at the center terminal wire of the connector. Check this at idle (throttle plate closed) and at wide open throttle (WOT). At idle, TPS output voltage should be greater than .350 millivolts but

less than 900 millivolts. At wide open throttle, TPS output voltage must be less than 4.5 volts. The output voltage should increase gradually as the throttle plate is slowly opened from idle to WOT.

THROTTLE POSITION SENSOR (TPS)—4.0L ENGINE

To perform a complete test of the TPS (Fig. 58) and its circuitry, refer to the DRB scan tool and appropriate Powertrain Diagnostics Procedures manual. To test the TPS only, refer to the following:

The TPS can be tested with a digital voltmeter. The center terminal of the TPS is the output terminal.

With the ignition key in the ON position, check the TPS output voltage at the center terminal wire of the connector. Check this at idle (throttle plate closed) and at wide open throttle (WOT). At idle, TPS output voltage should be greater than .350 millivolts and less than 900 millivolts. At wide open throttle, TPS output voltage must be less than 4.5 volts. The output voltage should increase gradually as the throttle plate is slowly opened from idle to WOT.

THROTTLE BODY MINIMUM AIR FLOW CHECK PROCEDURE

5.2L/5.9L ENGINE

The following test procedure has been developed to check throttle body calibrations for correct idle conditions. The procedure should be used to diagnose the throttle body for conditions that may cause idle problems. **This procedure should be used only after normal diagnostic procedures have failed to produce results that indicate a throttle body related problem. Be sure to check for proper operation of the idle air control motor before performing this test.**

A special fixed orifice tool (number 6714) (Fig. 60) must be used for the following test.

SPECIAL TOOL 6714

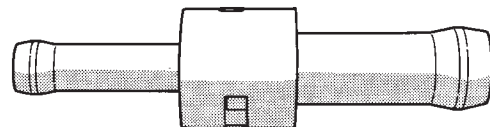


Fig. 60 Fixed Orifice Tool

(1) Start the engine and bring to operating temperature. Be sure all accessories are off before performing this test.

J9414-7

DIAGNOSIS AND TESTING (Continued)

(2) Shut off the engine and remove the air duct at throttle body.

(3) Disconnect the vacuum line at the PCV valve (Fig. 61).

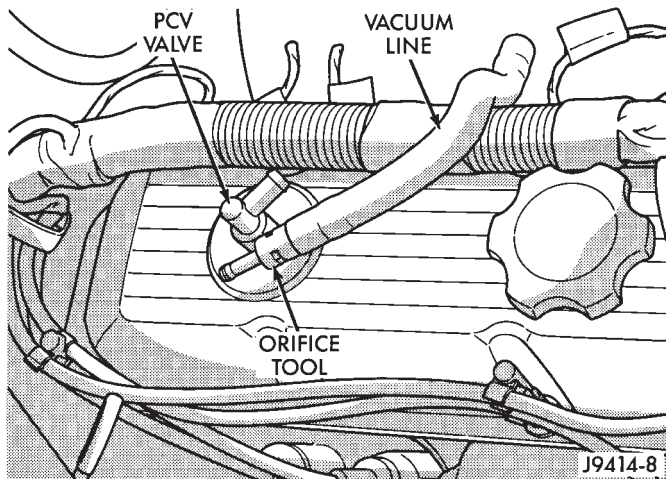


Fig. 61 Install Orifice Tool

(4) Install the 0.185 inch orifice tool (number 6714) into the disconnected vacuum line in place of the PCV valve (Fig. 61).

(5) Disconnect the idle purge vacuum line from fitting at throttle body. This vacuum line is located on the front of throttle body next to the MAP sensor (Fig. 62). Cap the fitting at throttle body after vacuum line has been removed.

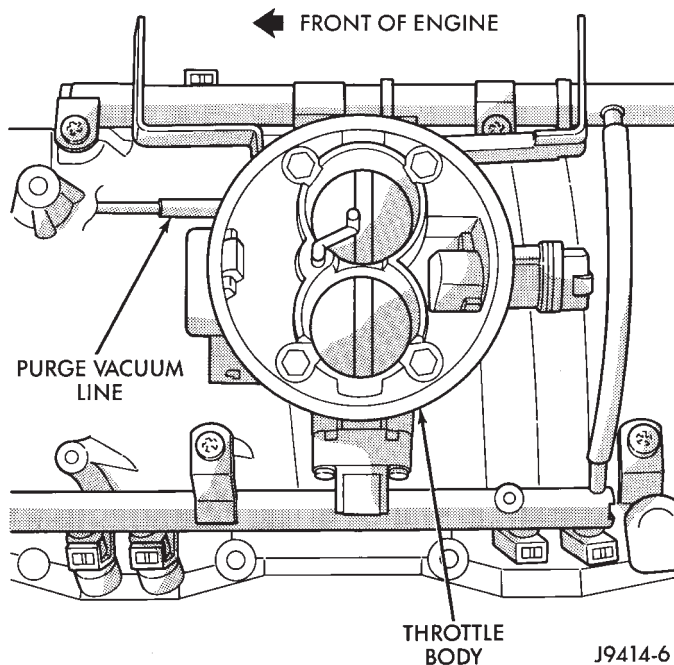


Fig. 62 Idle Purge Line

(6) Connect the DRB scan tool to the 16-way data link connector. This connector is located under the instrument panel to the left of the steering column.

Refer to the appropriate Powertrain Diagnostic Procedures service manual for DRB operation.

(7) Start the engine and allow to warm up.

(8) Using the DRB scan tool, scroll through the menus as follows: select—Stand Alone DRB III, select 1994–1997 Diagnostics, select—Engine, select—System Test, select—Minimum Air Flow.

(9) The DRB scan tool will count down to stabilize the idle rpm and display the minimum air flow idle rpm. The idle rpm should be between **500 and 900 rpm**. If the idle speed is outside of these specifications, replace the throttle body. Refer to Throttle Body in the Component Removal/Installation section of this group.

(10) Disconnect the DRB scan tool from the vehicle.

(11) Remove cap from idle purge fitting at throttle body and install vacuum line.

(12) Remove orifice tool and connect vacuum line to PCV valve.

(13) Install air duct to throttle body.

REMOVAL AND INSTALLATION**AUTOMATIC SHUTDOWN (ASD) RELAY**

The ASD relay is located in the Power Distribution Center (PDC) (Fig. 63). Refer to label on PDC cover for relay location.

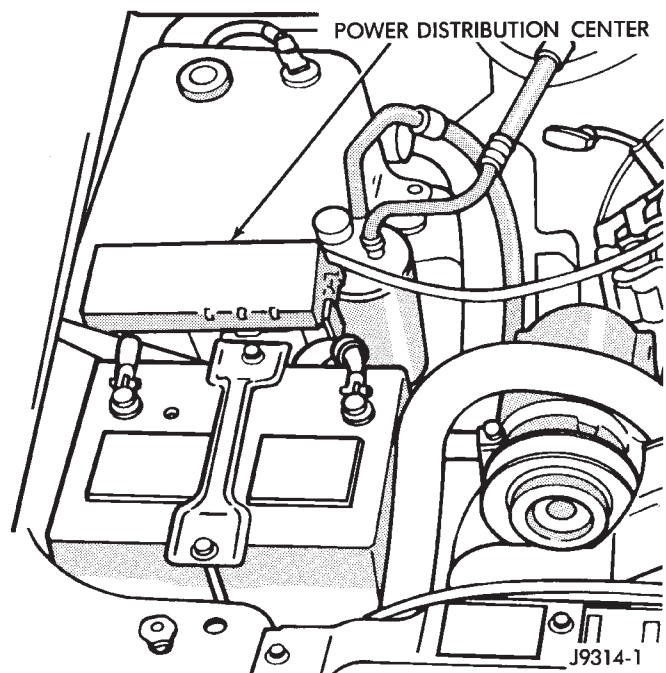


Fig. 63 Power Distribution Center (PDC) Location

REMOVAL

(1) Remove PDC cover.

(2) Remove relay from PDC.

REMOVAL AND INSTALLATION (Continued)

(3) Check condition of relay terminals and PDC connector terminals for damage or corrosion. Repair if necessary before installing relay.

(4) Check for pin height (pin height should be the same for all terminals within the PDC connector). Repair if necessary before installing relay.

INSTALLATION

- (1) Install relay to PDC.
- (2) Install cover to PDC.

FUEL PUMP RELAY

The fuel pump relay is located in the Power Distribution Center (PDC) (Fig. 63). Refer to label on PDC cover for relay location.

REMOVAL

- (1) Remove PDC cover.
- (2) Remove relay from PDC.
- (3) Check condition of relay terminals and PDC connector terminals for damage or corrosion. Repair if necessary before installing relay.
- (4) Check for pin height (pin height should be the same for all terminals within the PDC connector). Repair if necessary before installing relay.

INSTALLATION

- (1) Install relay to PDC.
- (2) Install cover to PDC.

THROTTLE BODY—5.2L/5.9L ENGINES

A (factory adjusted) set screw is used to mechanically limit the position of the throttle body throttle plate. **Never attempt to adjust the engine idle speed using this screw.** All idle speed functions are controlled by the powertrain control module (PCM).

REMOVAL

- (1) Remove the air duct at throttle body.
- (2) Disconnect throttle body electrical connectors at MAP sensor, IAC motor and TPS (Fig. 64).
- (3) Remove vacuum line at throttle body.
- (4) Remove all control cables from throttle body (lever) arm. Refer to the Accelerator Pedal and Throttle Cable section of this group for additional information.
- (5) Remove four throttle body mounting bolts (Fig. 65).
- (6) Remove throttle body from intake manifold.
- (7) Discard old throttle body-to-intake manifold gasket.

INSTALLATION

- (1) Clean the mating surfaces of the throttle body and the intake manifold.
- (2) Install new throttle body-to-intake manifold gasket.

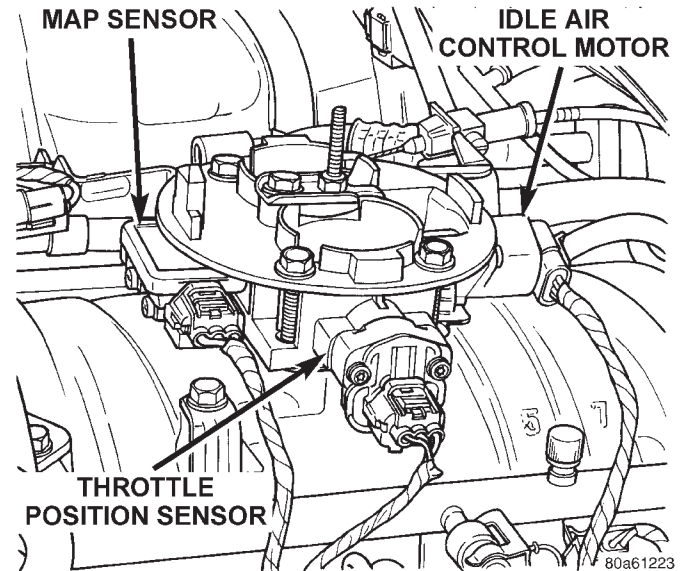


Fig. 64 Sensor Electrical Connectors—5.2L/5.9L Engines—Typical

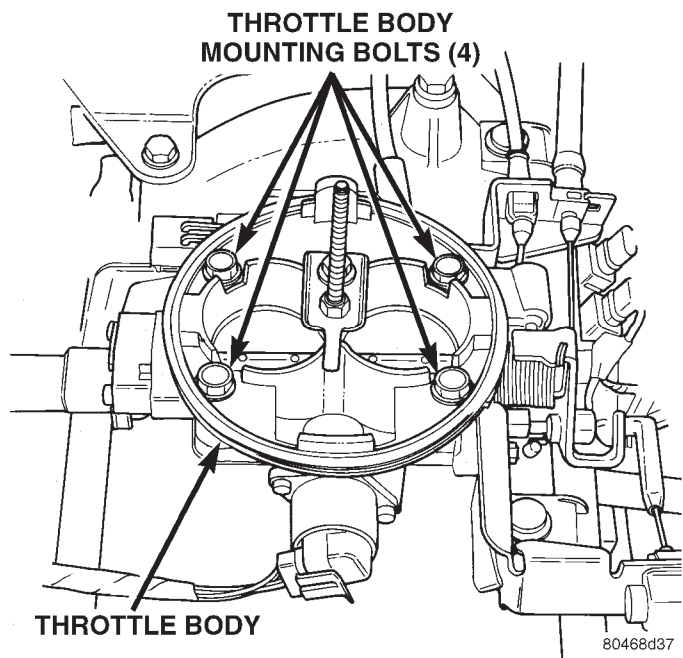


Fig. 65 Throttle Body Mounting Bolts—5.2L/5.9L Engines—Typical

- (3) Install throttle body to intake manifold.
- (4) Install four mounting bolts. Tighten bolts to 23 N·m (200 in. lbs.) torque.
- (5) Install control cables.
- (6) Install vacuum line to throttle body.
- (7) Install electrical connectors.

REMOVAL AND INSTALLATION (Continued)

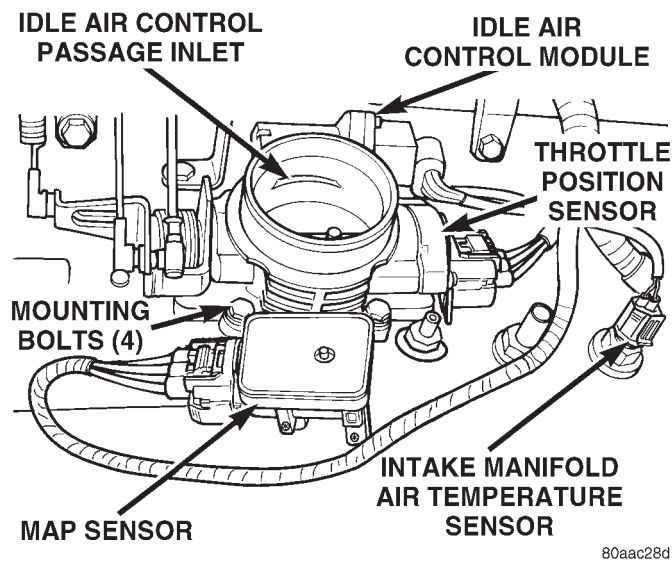
- (8) Install air duct at throttle body.

THROTTLE BODY—4.0L ENGINE

A (factory adjusted) set screw is used to mechanically limit the position of the throttle body throttle plate. **Never attempt to adjust the engine idle speed using this screw.** All idle speed functions are controlled by the powertrain control module (PCM).

REMOVAL

- (1) Remove the air cleaner duct at throttle body.
- (2) Disconnect throttle body electrical connectors at MAP sensor, IAC motor and TPS (Fig. 66).



80aac28d

Fig. 66 Throttle Body and Sensor Locations—4.0L Engine

- (3) Remove all control cables from throttle body (lever) arm. Refer to the Accelerator Pedal and Throttle Cable section of this group for additional information.
- (4) Remove four throttle body mounting bolts.
- (5) Remove throttle body from intake manifold.
- (6) Discard old throttle body-to-intake manifold gasket.

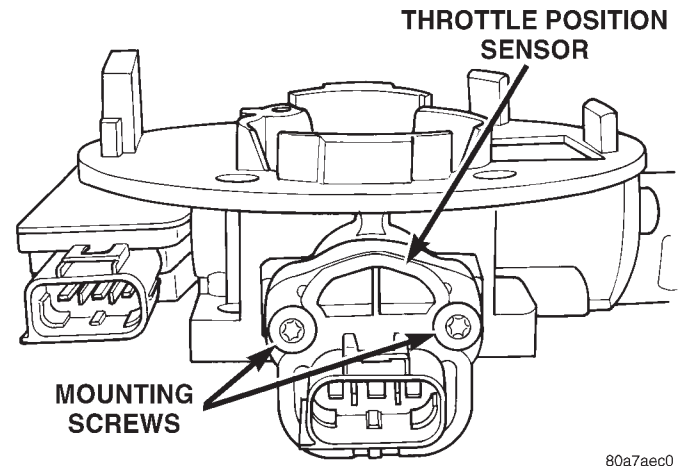
INSTALLATION

- (1) Clean the mating surfaces of the throttle body and the intake manifold.
- (2) Install new throttle body-to-intake manifold gasket.
- (3) Install throttle body to intake manifold.
- (4) Install four mounting bolts. Tighten bolts to 11 N·m (100 in. lbs.) torque.
- (5) Install control cables.
- (6) Install electrical connectors.
- (7) Install air duct at throttle body.

THROTTLE POSITION SENSOR (TPS)—5.2L/5.9L ENGINES**REMOVAL**

The TPS is located on the side of the throttle body.

- (1) Remove air duct at throttle body.
- (2) Disconnect TPS electrical connector.
- (3) Remove two TPS mounting bolts (Fig. 67).



80a7aec0

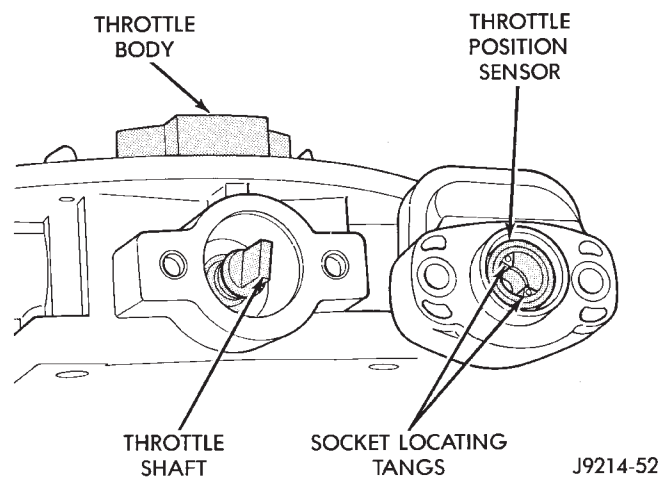
Fig. 67 TPS Mounting Bolts—5.2L/5.9L Engines—Typical

- (4) Remove TPS from throttle body.

INSTALLATION

The throttle shaft end of the throttle body slides into a socket in the TPS (Fig. 68). The TPS must be installed so that it can be rotated a few degrees. If the sensor will not rotate, install the sensor with the throttle shaft on the other side of the socket tangs. The TPS will be under slight tension when rotated.

- (1) Install the TPS and two retaining bolts.
- (2) Tighten bolts to 7 N·m (60 in. lbs.) torque.



J9214-52

Fig. 68 Installation—5.2L/5.9L Engines—Typical

REMOVAL AND INSTALLATION (Continued)

- (3) Manually operate the throttle control lever by hand to check for any binding of the TPS.
- (4) Connect TPS electrical connector to TPS.
- (5) Install air duct at throttle body.

THROTTLE POSITION SENSOR (TPS)—4.0L ENGINE

The TPS is mounted to the throttle body.

REMOVAL

- (1) Disconnect TPS electrical connector.
- (2) Remove TPS mounting screws (Fig. 69).
- (3) Remove TPS.

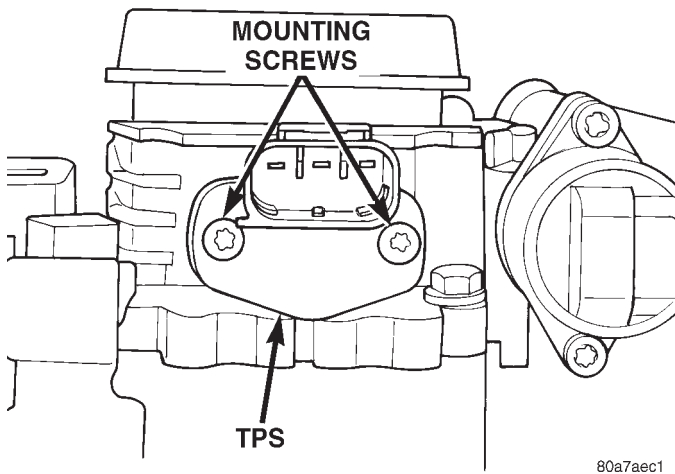


Fig. 69 TPS Mounting Screws—4.0L Engine

INSTALLATION

The throttle shaft end of the throttle body slides into a socket in the TPS (Fig. 70). The TPS must be installed so that it can be rotated a few degrees. (If the sensor will not rotate, install the sensor with the throttle shaft on the other side of the socket tangs). The TPS will be under slight tension when rotated.

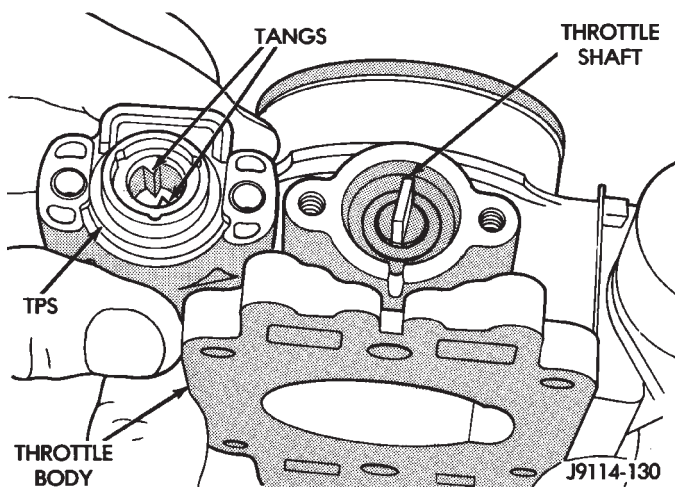


Fig. 70 Throttle Position Sensor Installation—4.0L Engine

- (1) Install the TPS and retaining screws.
- (2) Tighten screws to 7 N-m (60 in. lbs.) torque.
- (3) Connect TPS electrical connector to TPS.
- (4) Manually operate the throttle (by hand) to check for any TPS binding before starting the engine.

IDLE AIR CONTROL (IAC) MOTOR—5.2L/5.9L ENGINES

The IAC motor is located on the back of the throttle body.

REMOVAL

- (1) Remove air duct at throttle body.
- (2) Disconnect electrical connector from IAC motor.
- (3) Remove two mounting bolts (screws) (Fig. 71).

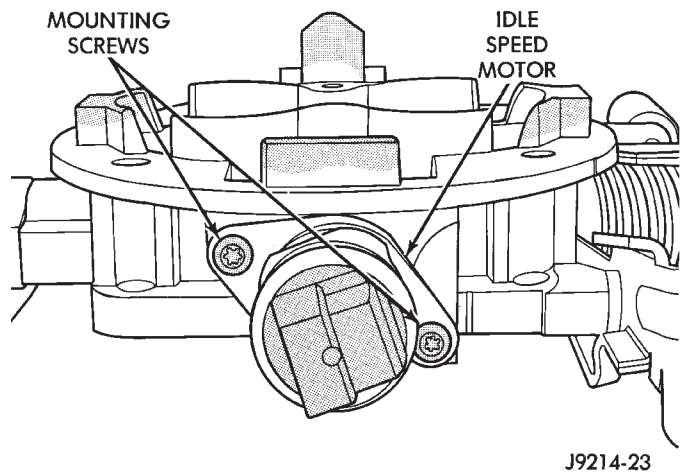


Fig. 71 Mounting Bolts (Screws)—IAC Motor—5.2L/5.9L Engines—Typical

- (4) Remove IAC motor from throttle body.

INSTALLATION

- (1) Install IAC motor to throttle body.
- (2) Install and tighten two mounting bolts (screws) to 7 N-m (60 in. lbs.) torque.
- (3) Install electrical connector.
- (4) Install air duct at throttle body.

IDLE AIR CONTROL (IAC) MOTOR—4.0L ENGINE

The IAC motor is located on the side of the throttle body.

REMOVAL

- (1) Remove air cleaner tube at throttle body.
- (2) Disconnect electrical connector from IAC motor.
- (3) Remove two mounting bolts (screws) (Fig. 72).
- (4) Remove IAC motor from throttle body.

INSTALLATION

- (1) Install IAC motor to throttle body.
- (2) Install and tighten two mounting bolts (screws) to 7 N-m (60 in. lbs.) torque.

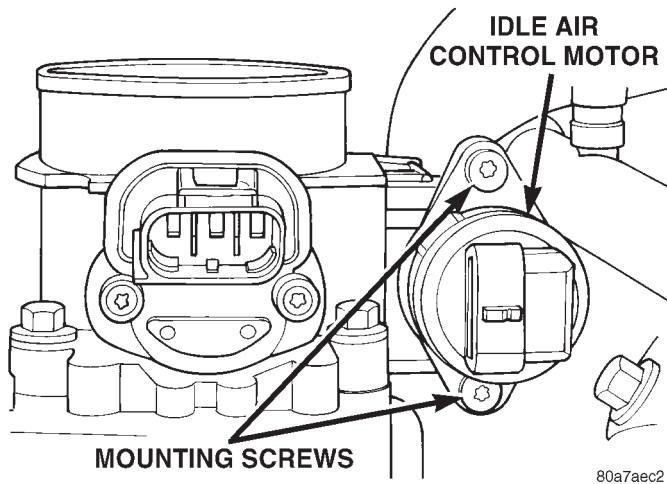
REMOVAL AND INSTALLATION (Continued)

Fig. 72 Mounting Bolts (Screws)—IAC Motor—4.0L Engine

- (3) Install electrical connector.
- (4) Install air cleaner tube to throttle body.

MANIFOLD ABSOLUTE PRESSURE (MAP) SENSOR—5.2L/5.9L ENGINES

The MAP sensor is located on the front of the throttle body (Fig. 73). An L-shaped rubber fitting is used to connect the MAP sensor to throttle body (Fig. 74).

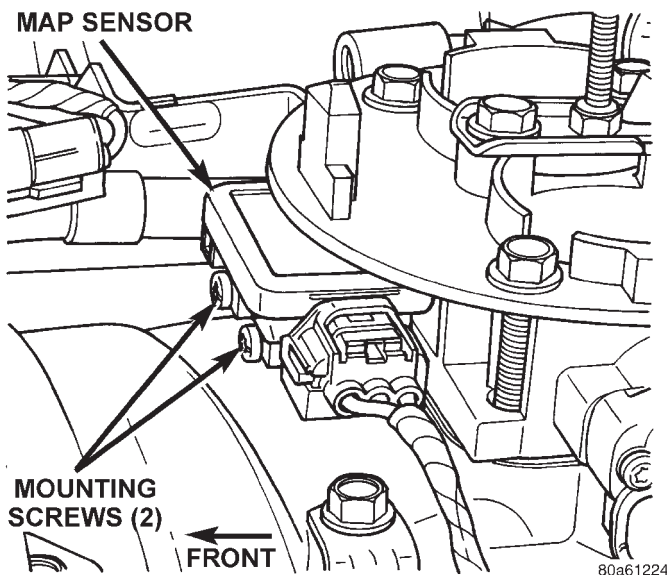


Fig. 73 MAP Sensor Mounting Screws—5.2L/5.9L Engines

REMOVAL

- (1) Remove air duct at throttle body.
- (2) Disconnect electrical connector at sensor.
- (3) Remove two MAP sensor mounting bolts (screws) (Fig. 74).

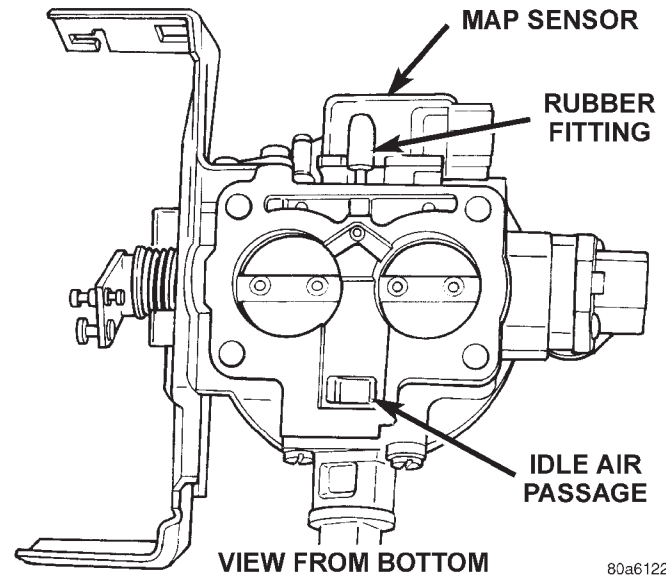


Fig. 74 MAP Sensor L-Shaped Rubber Fitting—5.2L/5.9L Engines

- (4) While removing MAP sensor, slide the vacuum rubber L-shaped fitting (Fig. 74) from the throttle body.
- (5) Remove rubber L-shaped fitting from MAP sensor.

INSTALLATION

- (1) Install rubber L-shaped fitting to MAP sensor.
- (2) Position sensor to throttle body while guiding rubber fitting over throttle body vacuum nipple.
- (3) Install MAP sensor mounting bolts (screws). Tighten screws to 3 N·m (25 in. lbs.) torque.
- (4) Connect electrical connector.
- (5) Install air duct at throttle body.

MANIFOLD ABSOLUTE PRESSURE (MAP) SENSOR—4.0L ENGINE

The MAP sensor is mounted to the side of the throttle body (Fig. 75). An L-shaped rubber fitting is used to connect the MAP sensor to throttle body (Fig. 76).

REMOVAL

- (1) Remove air cleaner intake tube at throttle body.
- (2) Remove two MAP sensor mounting bolts (screws) (Fig. 76).
- (3) While removing MAP sensor, slide the rubber L-shaped fitting (Fig. 76) from the throttle body.
- (4) Remove rubber L-shaped fitting from MAP sensor.

INSTALLATION

- (1) Install rubber L-shaped fitting to MAP sensor.

REMOVAL AND INSTALLATION (Continued)

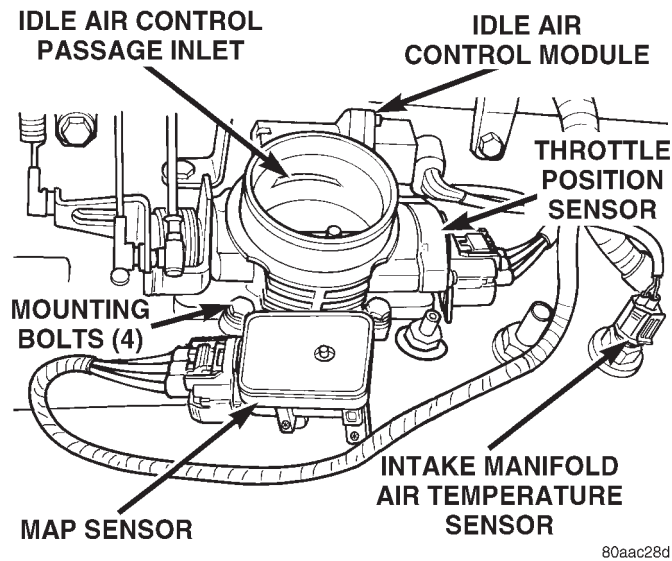


Fig. 75 MAP Sensor Location—4.0L Engine

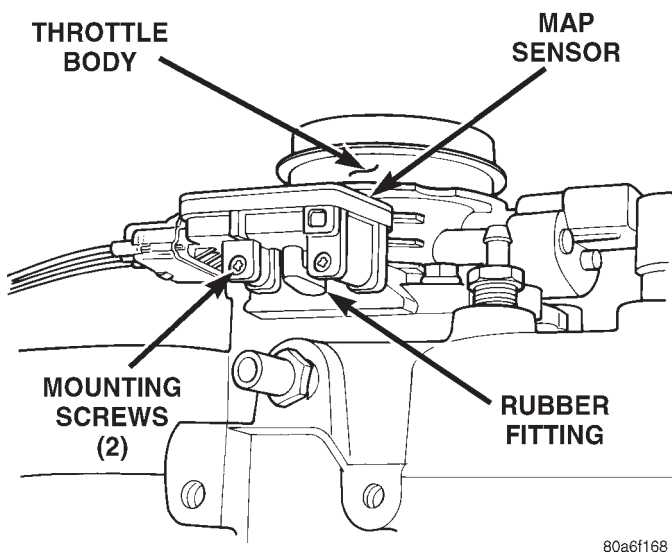


Fig. 76 Rubber L-Shaped Fitting—MAP Sensor-to-Throttle Body—4.0L Engine

- (2) Position sensor to throttle body while guiding rubber fitting over throttle body vacuum nipple.
- (3) Install MAP sensor mounting bolts (screws). Tighten screws to 3 N·m (25 in. lbs.) torque.
- (4) Install air cleaner intake tube.

DUTY CYCLE EVAP CANISTER PURGE SOLENOID

Refer to Group 25, Emission Control System for removal/installation procedures.

POWERTRAIN CONTROL MODULE (PCM)

The PCM is located on the cowl panel in the right/rear side of the engine compartment (Fig. 77).

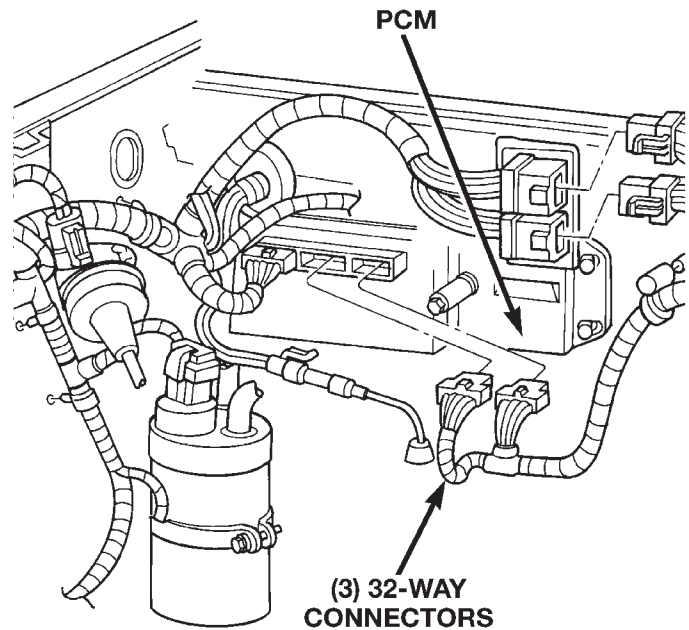


Fig. 77 Powertrain Control Module (PCM) Location

REMOVAL

To avoid possible voltage spike damage to the PCM, ignition key must be off, and negative battery cable must be disconnected before unplugging PCM connectors.

- (1) Disconnect negative battery cable at battery.
- (2) Remove cover over electrical connectors. Cover snaps onto PCM.
- (3) Remove the coolant reserve/overflow tank (one bolt and two nuts) (Fig. 78).

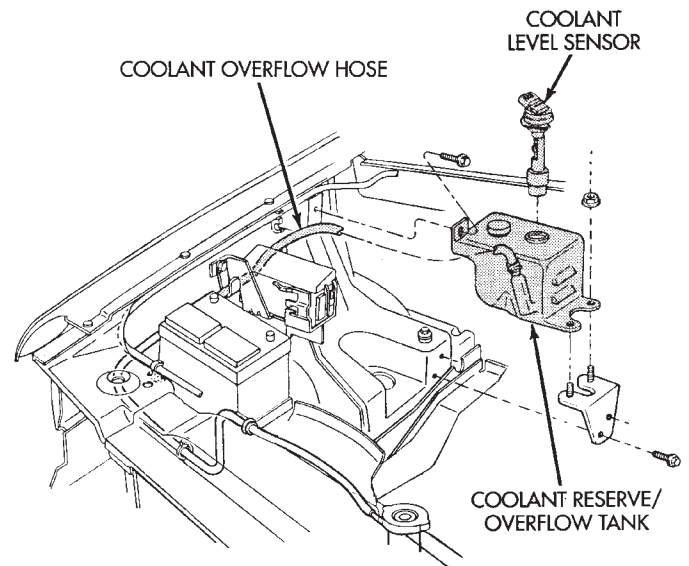


Fig. 78 Coolant Reserve/Overflow Tank Mounting

REMOVAL AND INSTALLATION (Continued)

- (4) Carefully unplug the three 32-way connectors at PCM.
- (5) Remove the three PCM mounting bolts (Fig. 79).
- (6) Remove PCM.

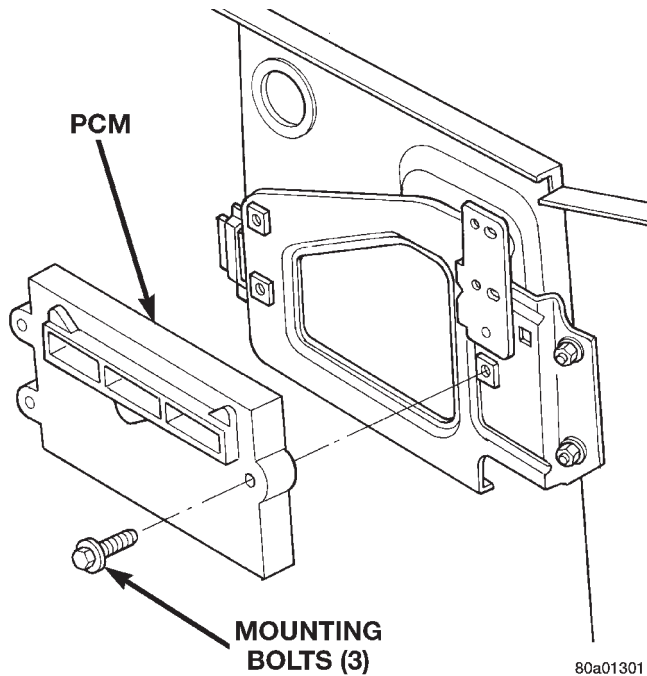


Fig. 79 Powertrain Control Module (PCM) Mounting INSTALLATION

- (1) Check the pins in the three 32-way electrical connectors for damage. Repair as necessary.
- (2) Install PCM. Tighten three mounting bolts to 1 N·m (9 in. lbs.) torque.
- (3) Install three 32-way connectors.
- (4) Install cover over electrical connectors. Cover snaps onto PCM.
- (5) Install coolant reserve/overflow tank.
- (6) Connect negative cable to battery.
- (7) Use the DRB scan tool to reprogram new PCM with vehicle's original Identification Number (VIN) and original vehicle mileage.

CRANKSHAFT POSITION SENSOR

Refer to Group 8D, Ignition System for removal/installation procedures.

CAMSHAFT POSITION SENSOR

For removal/installation procedures, refer to Group 8D, Ignition System. See Camshaft Position Sensor.

OXYGEN SENSOR—5.2L/5.9L ENGINES

The upstream O₂S sensor is located in the exhaust downpipe. The downstream sensor is located near outlet end of catalytic converter. Refer to (Fig. 80) or (Fig. 81).

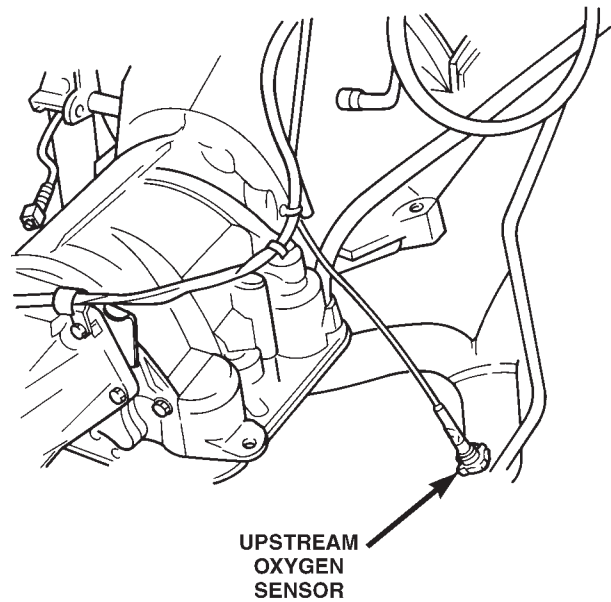


Fig. 80 Upstream Oxygen Sensor Location—5.2L/5.9L Engines

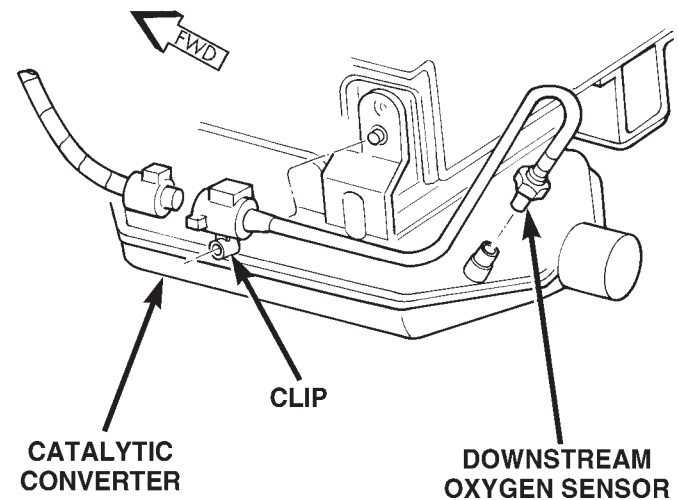


Fig. 81 Downstream Oxygen Sensor Location—All Engines

REMOVAL

WARNING: THE EXHAUST MANIFOLD, EXHAUST PIPES AND CATALYTIC CONVERTER BECOME VERY HOT DURING ENGINE OPERATION. ALLOW ENGINE TO COOL BEFORE REMOVING OXYGEN SENSOR.

REMOVAL AND INSTALLATION (Continued)

- (1) Raise and support vehicle.
- (2) Downstream Sensor Only: Disconnect O2S wiring connector clip (Fig. 81) at body. Remove clip from O2S electrical connector and discard.
- (3) Disconnect O2S pigtail harness wire connector from main connector.

CAUTION: When disconnecting the sensor electrical connector, do not pull directly on wire going into sensor.

- (4) Remove O2S sensor. Snap-On oxygen sensor wrench (number YA 8875) may be used for removal and installation.

INSTALLATION

Threads of new oxygen sensors are factory coated with anti-seize compound to aid in removal. **DO NOT add any additional anti-seize compound to threads of a new oxygen sensor.**

- (1) Install O2S sensor. Tighten to 30 N·m (22 ft. lbs.) torque.
- (2) Connect O2S sensor wire connector to main wiring harness.
- (3) Downstream Sensor Only: Install new wiring connector clip into O2S electrical connector. Snap this clip to body. The O2S pigtail harness must be clipped to body to prevent mechanical damage from propshaft.
- (4) Lower the vehicle.

OXYGEN SENSOR—4.0L ENGINE

The upstream O2S sensor is located in the exhaust downpipe. The downstream sensor is located near outlet end of catalytic converter. Refer to (Fig. 82) or (Fig. 81).

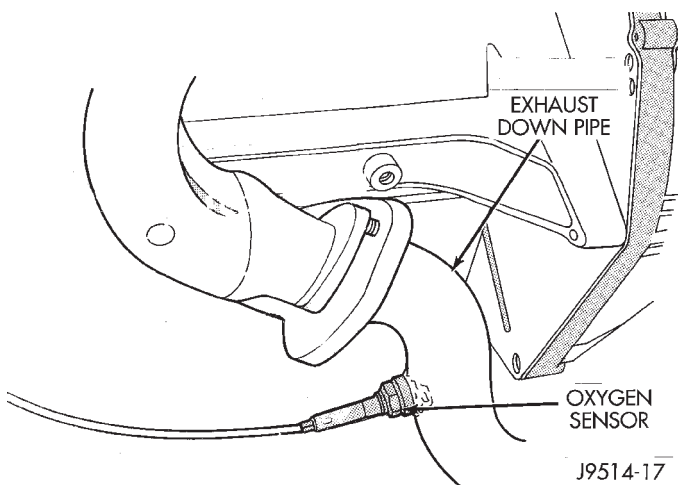


Fig. 82 Upstream Oxygen Sensor Location—4.0L Engine

REMOVAL

WARNING: THE EXHAUST MANIFOLD, EXHAUST PIPES AND CATALYTIC CONVERTER BECOME VERY HOT DURING ENGINE OPERATION. ALLOW ENGINE TO COOL BEFORE REMOVING OXYGEN SENSOR.

- (1) Raise and support vehicle.
- (2) Downstream Sensor Only: Disconnect O2S wiring connector clip (Fig. 81) at body. Remove clip from O2S electrical connector and discard.
- (3) Disconnect O2S pigtail harness wire connector from main connector.

CAUTION: When disconnecting the sensor electrical connector, do not pull directly on wire going into sensor.

- (4) Remove O2S sensor. Snap-On oxygen sensor wrench (number YA 8875) may be used for removal and installation.

INSTALLATION

Threads of new oxygen sensors are factory coated with anti-seize compound to aid in removal. **DO NOT add any additional anti-seize compound to the threads of a new oxygen sensor.**

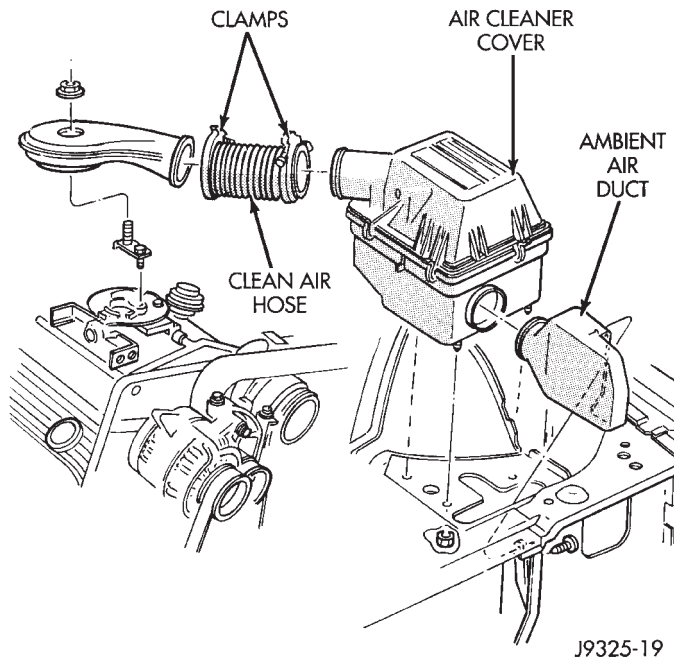
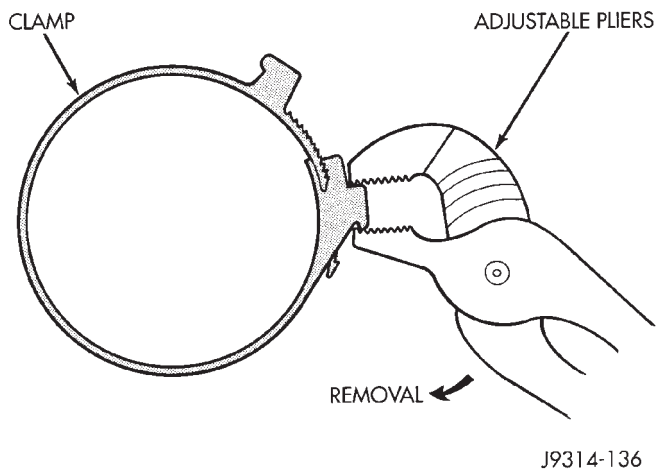
- (1) Install the O2S sensor. Tighten to 30 N·m (22 ft. lbs.) torque.
- (2) Connect O2S sensor wire connector to main wiring harness.
- (3) Downstream Sensor Only: Install new wiring connector clip into O2S electrical connector. Snap this clip to body. The O2S pigtail harness must be clipped to body to prevent mechanical damage from propshaft.
- (4) Lower the vehicle.

AIR CLEANER HOUSING**REMOVAL**

- (1) Unlock clean air hose clamp (Fig. 83) at air cleaner cover. To unlock the clamp, attach adjustable pliers to clamp and rotate pliers as shown in (Fig. 84). Remove clean air hose at cover.
- (2) Remove crankcase breather/filter hose at air cleaner cover.
- (3) From under vehicle, remove three housing nuts (Fig. 83).
- (4) Release the air cleaner housing from the ambient air duct and remove housing from vehicle.

INSTALLATION

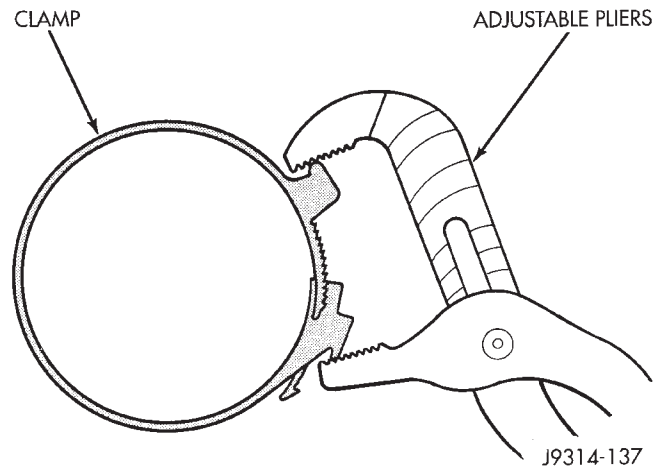
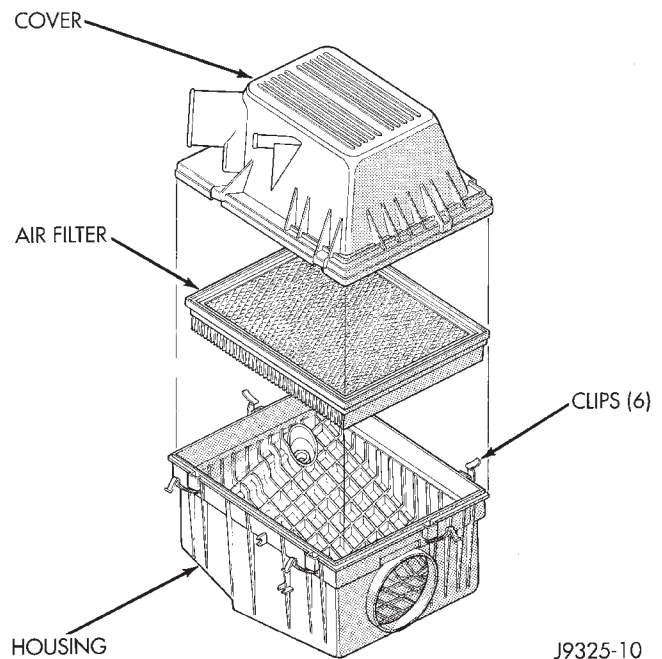
- (1) Position air cleaner housing to body and ambient air duct (Fig. 83).
- (2) Install three nuts and tighten to 10 N·m (93 in. lbs.) torque.

REMOVAL AND INSTALLATION (Continued)**Fig. 83 Air Cleaner—5.2L V-8 Engine Shown****Fig. 84 Clamp Removal**

- (3) Install crankcase breather/filter hose to cover.
- (4) Install clamp to cover. Compress the clamp snugly with adjustable pliers as shown in (Fig. 85).

AIR CLEANER ELEMENT (FILTER)**REMOVAL/INSTALLATION**

- (1) Pry back the six clips retaining the air cleaner cover to the air cleaner housing (Fig. 86).
- (2) Lift the cover up and position to the side.
- (3) Remove air cleaner element.
- (4) Clean the inside of air cleaner housing before installing new element.
- (5) Reverse the preceding operation for installation. Be sure the air cleaner cover is properly seated to air cleaner housing.

**Fig. 85 Clamp Installation****Fig. 86 Air Cleaner Element Removal/Installation**
ENGINE COOLANT TEMPERATURE SENSOR—5.2L/5.9L ENGINES**REMOVAL**

WARNING: HOT, PRESSURIZED COOLANT CAN CAUSE INJURY BY SCALDING. COOLING SYSTEM MUST BE PARTIALLY DRAINED BEFORE REMOVING THE COOLANT TEMPERATURE SENSOR. REFER TO GROUP 7, COOLING.

- (1) Partially drain cooling system. Refer to Group 7, Cooling.
- (2) Disconnect electrical connector from sensor (Fig. 87).

REMOVAL AND INSTALLATION (Continued)

(3) **Engines with air conditioning:** When removing the connector from sensor, do not pull directly on wiring harness. Fabricate an L-shaped hook tool from a coat hanger (approximately eight inches long). Place the hook part of tool under the connector for removal. The connector is snapped onto the sensor. It is not equipped with a lock type tab.

(4) Remove sensor from intake manifold.

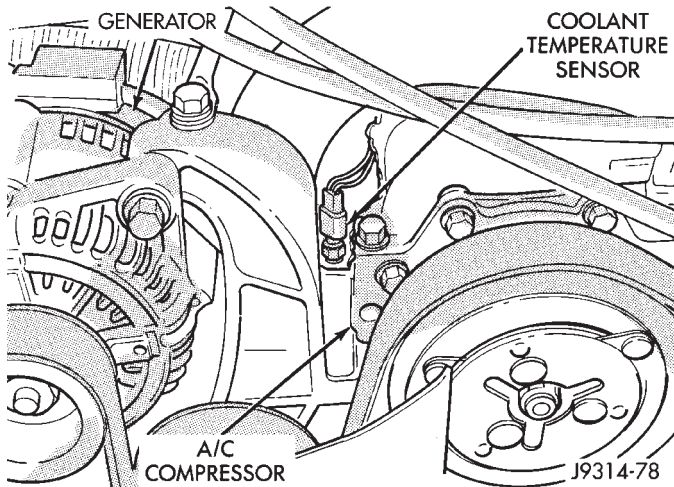


Fig. 87 Engine Coolant Temperature Sensor—5.2L/5.9L Engines

INSTALLATION

- (1) Install sensor.
- (2) Tighten to 11 N·m (8 ft. lbs.) torque.
- (3) Connect electrical connector to sensor. The sensor connector is symmetrical (not indexed). It can be installed to the sensor in either direction.
- (4) Replace any lost engine coolant. Refer to Group 7, Cooling System.

ENGINE COOLANT TEMPERATURE SENSOR—4.0L ENGINE

The coolant temperature sensor is installed in the thermostat housing (Fig. 88).

REMOVAL

- (1) Partially drain cooling system until the coolant level is below the cylinder head. Observe the **WARNINGS** in Group 7, Cooling.
- (2) Disconnect the coolant temperature sensor wire connector.
- (3) Remove the sensor from the thermostat housing.

INSTALLATION

- (1) Apply sealant to sensor threads.
- (2) Install coolant temperature sensor into the thermostat housing. Tighten to 11 N·m (8 ft. lbs.) torque.
- (3) Connect the wire connector.

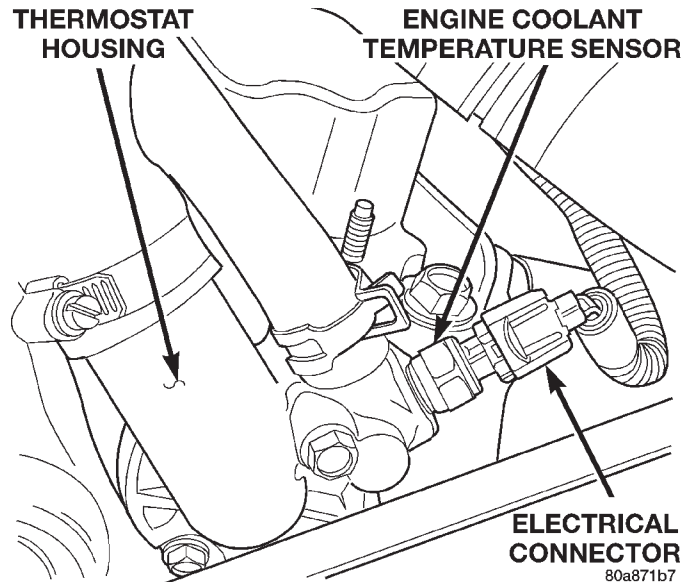


Fig. 88 Engine Coolant Temperature Sensor—4.0L Engine

(4) Fill the cooling system. Refer to Group 7, Cooling System.

INTAKE MANIFOLD AIR TEMPERATURE SENSOR—5.2L/5.9L ENGINES

The intake manifold air temperature sensor is located in the front/side of the intake manifold (Fig. 89).

REMOVAL

- (1) Disconnect electrical connector at sensor (Fig. 89).
- (2) Remove sensor from intake manifold.

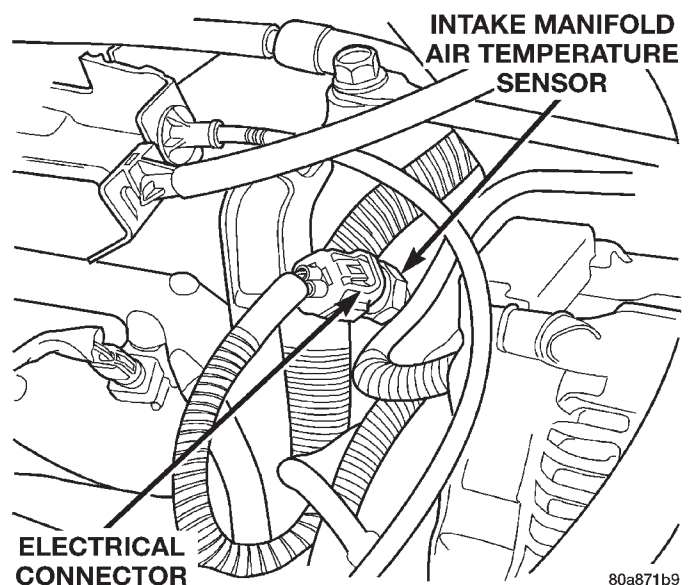


Fig. 89 Air Temperature Sensor—5.2L/5.9L Engines—Typical

REMOVAL AND INSTALLATION (Continued)**INSTALLATION**

- (1) Install sensor to intake manifold. Tighten to 28 N·m (20 ft. lbs.) torque.
- (2) Install electrical connector.

INTAKE MANIFOLD AIR TEMPERATURE SENSOR—4.0L ENGINE

The intake manifold air temperature sensor is installed into the intake manifold plenum near the throttle body (Fig. 90).

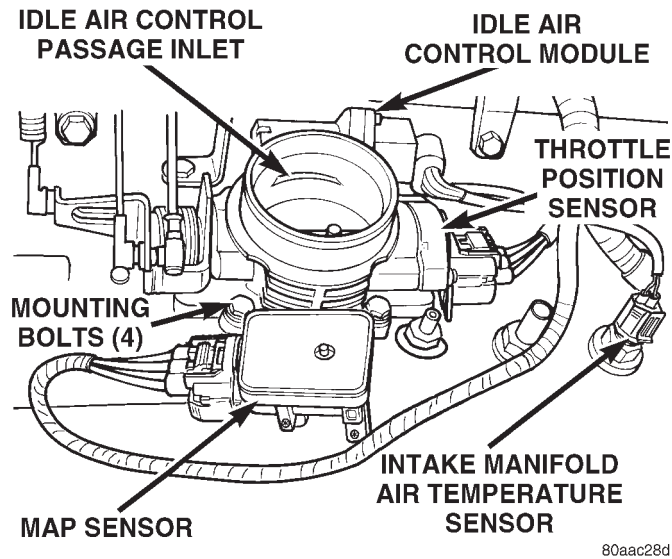


Fig. 90 Intake Air Sensor Location—4.0L Engine

REMOVAL

- (1) Disconnect the electrical connector from the sensor.
- (2) Remove the sensor from the intake manifold.

INSTALLATION

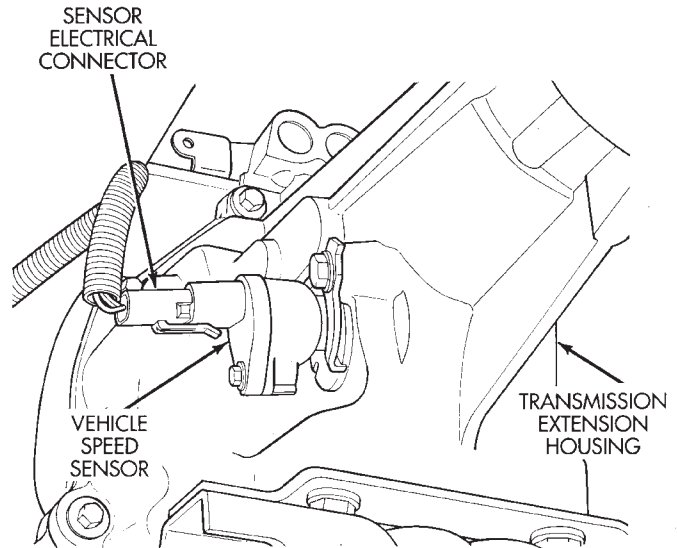
- (1) Install the sensor into the intake manifold. Tighten the sensor to 28 N·m (20 ft. lbs.) torque.
- (2) Connect the electrical connector to the sensor.

VEHICLE SPEED SENSOR

The vehicle speed sensor is located on the speedometer pinion gear adapter (Fig. 91) or (Fig. 92). The pinion gear adapter is located on the extension housing of the transmission (drivers side).

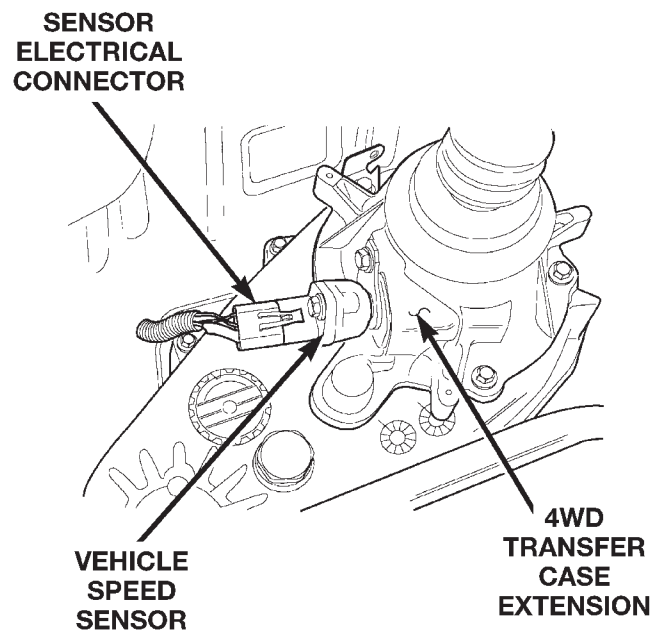
REMOVAL

- (1) Raise and support vehicle.
- (2) Disconnect the electrical connector from the sensor.
- (3) Remove the sensor mounting bolt (Fig. 93).
- (4) Remove the sensor (pull straight out) from the speedometer pinion gear adapter (Fig. 93). Do not remove the gear adapter from the transmission.



J9414-60

Fig. 91 Vehicle Speed Sensor Location—2WD—Typical



80a35409

Fig. 92 Vehicle Speed Sensor Location—4WD—Typical

INSTALLATION

- (1) Clean the inside of speedometer pinion gear adapter before installing speed sensor.
- (2) Install sensor into speedometer gear adapter and install mounting bolt. **Before tightening bolt, verify speed sensor is fully seated (mounted flush) to speedometer pinion gear adapter.**

REMOVAL AND INSTALLATION (Continued)

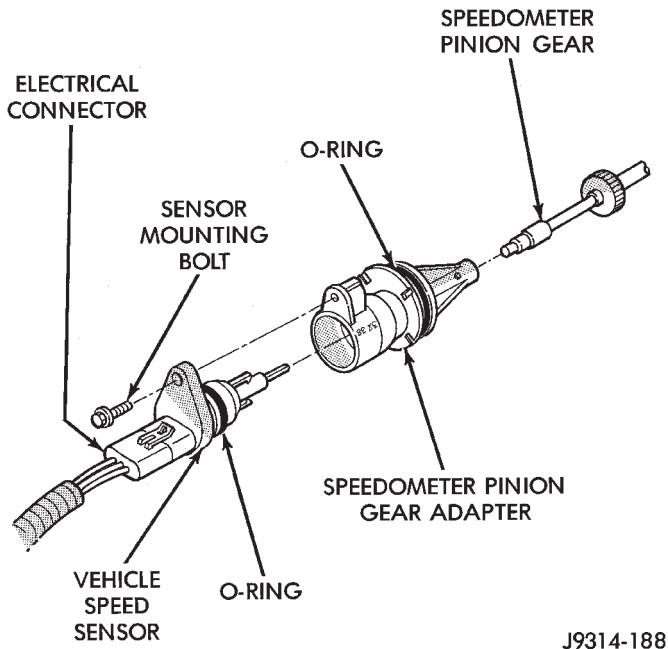


Fig. 93 Sensor Removal/Installation

- (3) Tighten sensor mounting bolt to 2.2 N·m (20 in. lbs.) torque.
- (4) Connect electrical connector to sensor.

SPECIFICATIONS

VECI LABEL

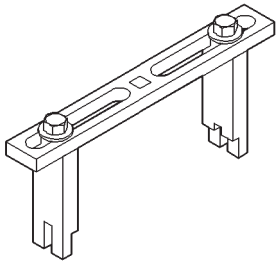
If anything differs between the specifications found on the Vehicle Emission Control Information (VECI) label and the following specifications, use specifications on VECI label. The VECI label is located in the engine compartment.

TORQUE CHART

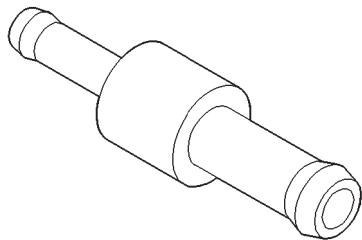
DESCRIPTION	TORQUE
Air Cleaner Housing Mount. Nuts	10 N·m (93 in. lbs.)
Engine Coolant Temperature Sensor— All Engines.	11 N·m (96 in. lbs.)
Fuel Hose Clamps	1 N·m (10 in. lbs.)
IAC Motor-To-Throttle Body Bolts	7 N·m (60 in. lbs.)
Intake Manifold Air Temp. Sensor— All Engines	28 N·m (20 ft. lbs.)
MAP Sensor Mounting Screws— All Engines	3 N·m (25 in. lbs.)
Oxygen Sensor—All Engines	30 N·m (22 ft. lbs.)
Powertrain Control Module Mounting Screws	1 N·m (9 in. lbs.)
Throttle Body Mounting Bolts— 5.2L/5.9L Engine	23 N·m (200 in. lbs.)
Throttle Body Mounting Bolts— 4.0L Engine	11 N·m (100 in. lbs.)
Throttle Position Sensor Mounting Screws—All Engines.	7 N·m (60 in. lbs.)
Vehicle Speed Sensor Mounting Bolt	2.2 N·m (20 in. lbs.)

SPECIAL TOOLS

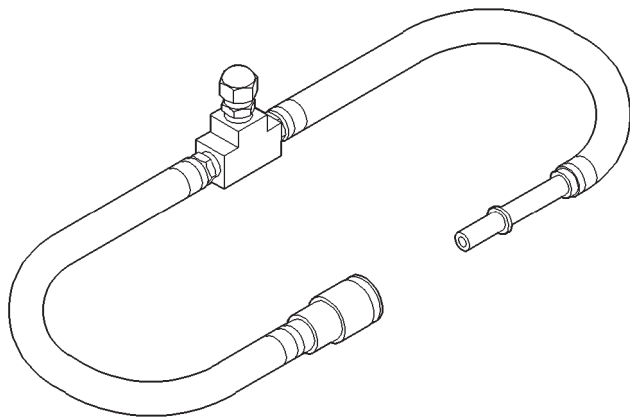
FUEL SYSTEM



Spanner Wrench—6856



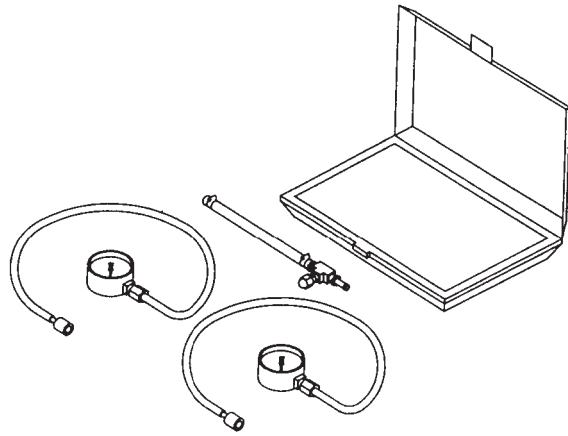
Fitting, Air Metering—6714



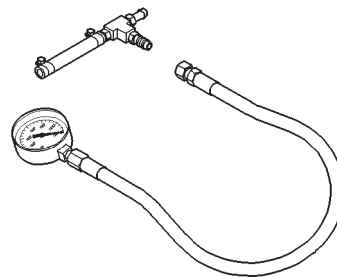
Adapters, Fuel Pressure Test—6541, 6539, 6631 or 6923



O2S (Oxygen Sensor) Remover/Installer—C-4907



Test Kit, Fuel Pressure—5069



Test Kit, Fuel Pressure—C-4799-B



Fuel Line Removal Tool—6782

FUEL SYSTEM—2.5L DIESEL ENGINE

CONTENTS

	page	page
FUEL DELIVERY SYSTEM—2.5L DIESEL ENGINE	3	
FUEL INJECTION SYSTEM—2.5L DIESEL ENGINE	25	
GENERAL INFORMATION		1

GENERAL INFORMATION

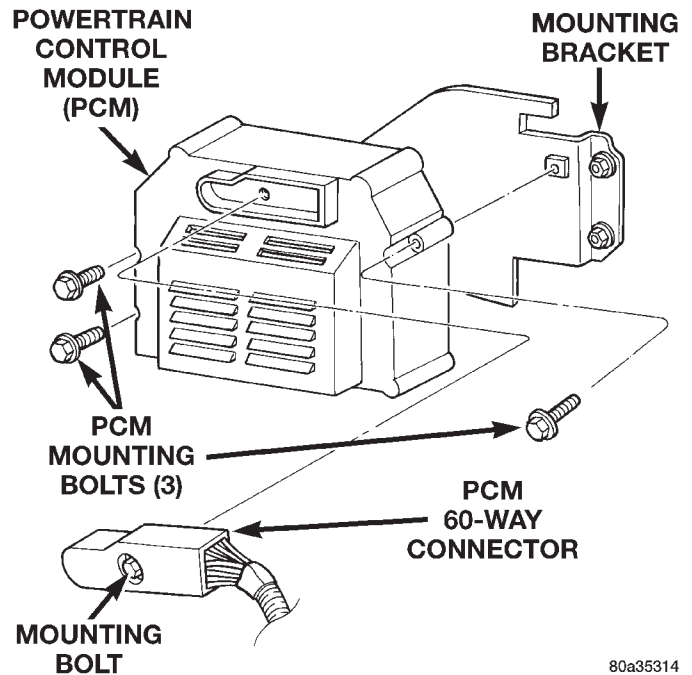
INDEX

	page	page
GENERAL INFORMATION		
FUEL REQUIREMENTS—2.5L DIESEL	2	
INTRODUCTION—2.5L DIESEL		1

GENERAL INFORMATION

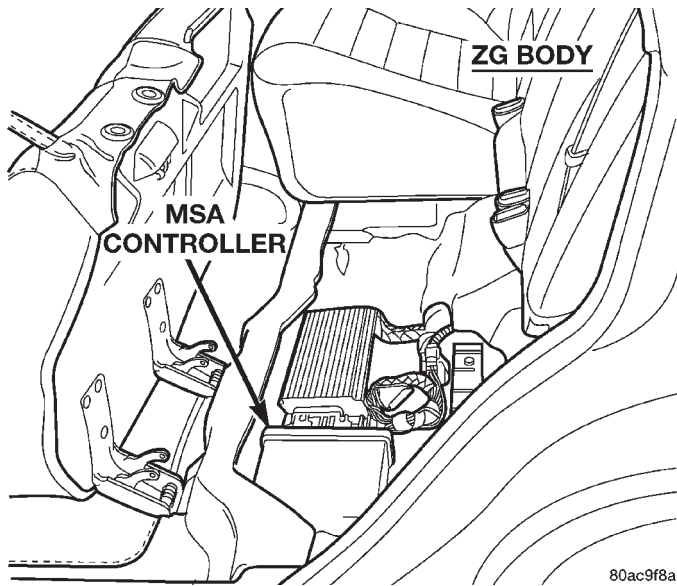
INTRODUCTION—2.5L DIESEL

Certain sensors that are part of the 2.5L diesel engine fuel system are monitored by the Bosch engine controller (MSA). Based on inputs received from these sensors, the MSA controls the amount of fuel and the timing of when it is delivered to the engine. The MSA controller is located under the left side rear seat. The Powertrain Control Module (PCM) is mounted to a bracket located in the right rear side of the engine compartment behind the coolant tank. It interfaces with the MSA electronically to control other components.



80a35314

Fig. 1 PCM Location

GENERAL INFORMATION (Continued)**Fig. 2 MSA Controller Location**

The **Fuel System** consists of: the fuel tank, fuel injection pump (engine mounted), fuel filter/water

separator, fuel tank module, electrical fuel gauge sending unit, glow plugs, glow plug relay, PCM, and all the electrical components that control the fuel system. It also consists of fuel tubes/lines/hoses and fittings, vacuum hoses, and fuel injector(s).

A **Fuel Return System**. A separate fuel return system is used. This will route excess fuel: from the fuel injectors; through individual injector drain tubes; through the fuel injection pump overflow valve; and back to the fuel tank through a separate fuel line.

The **Fuel Tank Assembly** consists of: the fuel tank, two pressure relief/rollover valves, fuel filler tube, fuel tank module containing a fuel gauge sending unit, and a pressure-vacuum filler cap.

FUEL REQUIREMENTS—2.5L DIESEL

Refer to the Lubrication and Maintenance section of this manual for information. Also refer to the Owner Manual.

FUEL DELIVERY SYSTEM—2.5L DIESEL ENGINE

INDEX

	page		page
DESCRIPTION AND OPERATION		FUEL SUPPLY RESTRICTIONS	13
FUEL DRAIN TUBES	7	GENERAL INFORMATION	9
FUEL FILTER/WATER SEPARATOR	4	HIGH-PRESSURE FUEL LINE LEAK TEST	14
FUEL GAUGE SENDING UNIT	4	VISUAL INSPECTION	9
FUEL HEATER	8	WASTEGATE (TURBOCHARGER)	14
FUEL HEATER RELAY	8	SERVICE PROCEDURES	
FUEL INJECTION PUMP	5	AIR BLEED PROCEDURES	14
FUEL INJECTORS	6	FUEL INJECTION PUMP TIMING	15
FUEL SHUTDOWN SOLENOID	5	REMOVAL AND INSTALLATION	
FUEL SYSTEM PRESSURE WARNING	3	ACCELERATOR PEDAL	15
FUEL TANK	4	AIR CLEANER ELEMENT	15
FUEL TANK MODULE	4	FUEL DRAIN TUBES	16
FUEL TUBES/LINES/HOSES AND CLAMPS—		FUEL FILTER/WATER SEPARATOR	16
LOW-PRESSURE TYPE	7	FUEL HEATER	17
HIGH-PRESSURE FUEL LINES	7	FUEL HEATER RELAY	17
INTRODUCTION	3	FUEL INJECTION PUMP	18
QUICK-CONNECT FITTINGS—LOW PRESSURE		FUEL INJECTORS	21
TYPE	7	FUEL LEVEL SENSOR	17
WASTEGATE (TURBOCHARGER)	8	FUEL RESERVOIR MODULE	23
DIAGNOSIS AND TESTING		FUEL TANK	22
AIR IN FUEL SYSTEM	12	HIGH-PRESSURE LINES	23
FUEL HEATER RELAY TEST	12	SPECIFICATIONS	
FUEL INJECTION PUMP TEST	13	FUEL INJECTOR FIRING SEQUENCE	24
FUEL INJECTOR SENSOR TEST	13	FUEL SYSTEM PRESSURE	24
FUEL INJECTOR TEST	12	FUEL TANK CAPACITY	24
FUEL SHUTDOWN SOLENOID TEST	14	IDLE SPEED	24

DESCRIPTION AND OPERATION

INTRODUCTION

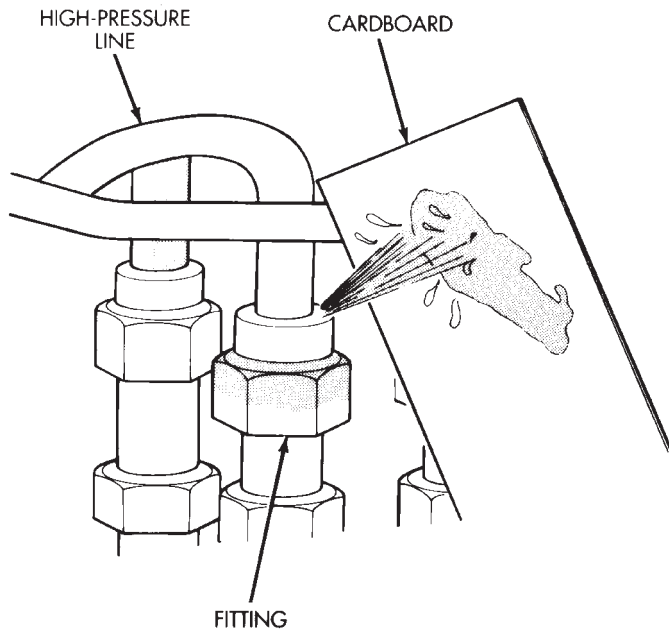
This Fuel Delivery section will cover components not controlled by the PCM. For components controlled by the PCM, refer to the Fuel Injection System—2.5L Diesel Engine section of this group.

The fuel heater relay, fuel heater and fuel gauge are not operated by the PCM. These components are controlled by the ignition (key) switch. All other fuel system electrical components necessary to operate the engine are controlled or regulated by the PCM.

FUEL SYSTEM PRESSURE WARNING

WARNING: HIGH-PRESSURE FUEL LINES DELIVER DIESEL FUEL UNDER EXTREME PRESSURE FROM THE INJECTION PUMP TO THE FUEL INJECTORS. THIS MAY BE AS HIGH AS 45,000 KPA (6526 PSI). USE EXTREME CAUTION WHEN INSPECTING FOR HIGH-PRESSURE FUEL LEAKS. INSPECT FOR HIGH-PRESSURE FUEL LEAKS WITH A SHEET OF CARDBOARD (Fig. 1). HIGH FUEL INJECTION PRESSURE CAN CAUSE PERSONAL INJURY IF CONTACT IS MADE WITH THE SKIN.

DESCRIPTION AND OPERATION (Continued)



J9414-130

Fig. 1 Typical Fuel Pressure Test at Injector

FUEL TANK

The fuel tank and tank mounting used with the diesel powered engine is the same as used with gasoline powered models, although the fuel tank module is different.

The fuel tank contains the fuel tank module and two rollover valves. Two fuel lines are routed to the fuel tank module. One line is used for fuel supply to the fuel filter/water separator. The other is used to return excess fuel back to the fuel tank.

The fuel tank module contains the fuel gauge electrical sending unit. **An electrical fuel pump is not used with the diesel engine.**

FUEL TANK MODULE

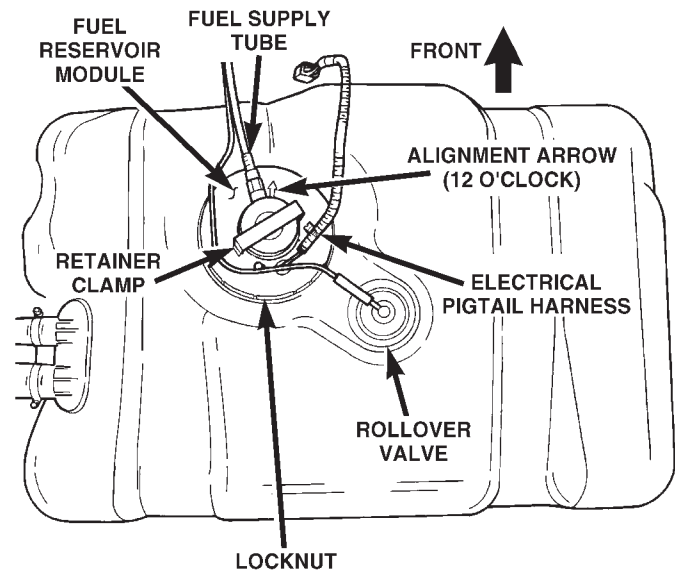
An electric fuel pump is not attached to the fuel tank module for diesel powered engines. Fuel is supplied by the fuel injection pump.

The fuel tank module is installed in the top of the fuel tank (Fig. 2). The fuel tank module contains the following components:

- Fuel reservoir
- A separate in-tank fuel filter
- Electric fuel gauge sending unit
- Fuel supply line connection
- Fuel return line connection

FUEL GAUGE SENDING UNIT

The fuel gauge sending unit is attached to the side of the fuel pump module. The sending unit consists of a float, an arm, and a variable resistor (track). The track is used to send an electrical signal used for fuel gauge operation.



80ad090c

Fig. 2 Fuel Tank

As the fuel level increases, the float and arm move up. This decreases the sending unit resistance, causing the PCM to send a signal to the fuel gauge on the instrument panel to read full. As the fuel level decreases, the float and arm move down. This increases the sending unit resistance, causing the PCM to send a signal to the fuel gauge on the instrument panel to read empty.

FUEL FILTER/WATER SEPARATOR

The fuel filter/water separator assembly is located in the engine compartment near the strut tower (Fig. 3).

The combination fuel filter/water separator protects the fuel injection pump by helping to remove water and contaminants from the fuel. Moisture collects at the bottom of the filter/separator in a plastic bowl.

The fuel filter/water separator assembly contains the fuel filter, fuel heater element, and fuel drain valve.

For information on the fuel heater, refer to Fuel Heater in this group.

Refer to the maintenance schedules in Group 0 in this manual for the recommended fuel filter replacement intervals.

For periodic draining of water from the bowl, refer to Fuel Filter/Water Separator Removal/Installation in this group.

DESCRIPTION AND OPERATION (Continued)

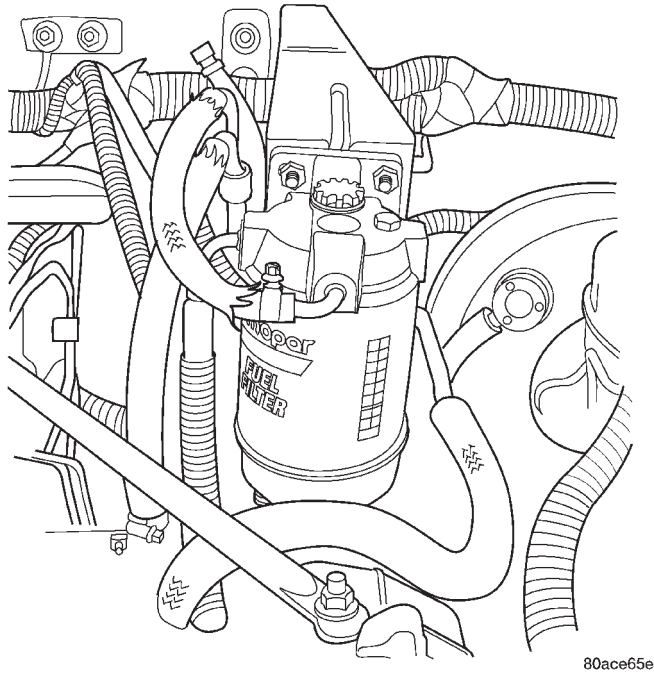


Fig. 3 Fuel Filter/Water Separator Location

FUEL SHUTDOWN SOLENOID

The fuel shutdown solenoid is controlled and operated by the MSA.

The fuel shutdown (shut-off) solenoid is used to electrically shut off the diesel fuel supply to the high-pressure fuel injection pump. The solenoid is mounted to the rear of the injection pump (Fig. 4).

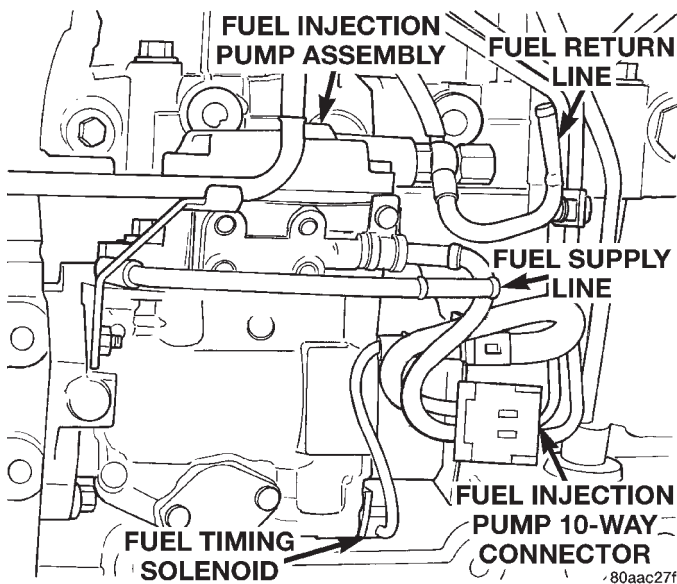


Fig. 4 Fuel Shutdown Solenoid and Overflow Valve Location

The solenoid controls starting and stopping of the engine regardless of the position of the accelerator pedal. When the ignition (key) switch is OFF, the solenoid is shut off and fuel flow is not allowed to the

fuel injection pump. When the key is placed in the ON or START positions, fuel supply is allowed at the injection pump.

FUEL INJECTION PUMP

The fuel injection pump is a mechanical distributor-type, Bosch VP36 series (Fig. 5). A gear on the end of the injection pump shaft meshes with the drive chain at the front of engine. The pump is mechanically timed to the engine. The MSA can make adjustments to the timing of the injection pump.

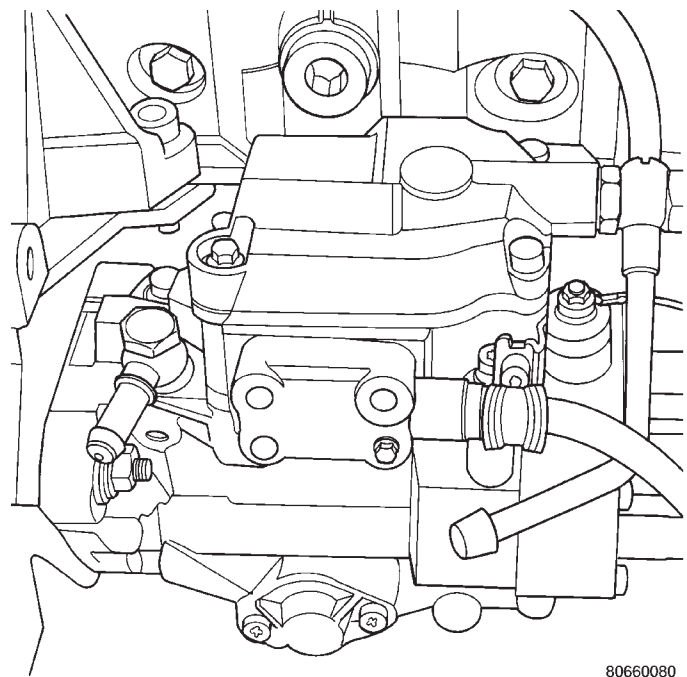


Fig. 5 Fuel Injection Pump

The injection pump contains the fuel shutdown solenoid, fuel temperature sensor, control sleeve sensor, fuel quantity actuator and the fuel timing solenoid (Fig. 5).

In the electronically controlled injection pump, the pump plunger works the same as the pump plunger in a mechanically controlled injection pump, but the amount of fuel and the time the fuel is injected is controlled by the vehicle's MSA, instead of by a mechanical governor assembly. A solenoid controlled by the MSA is used in place of the mechanical governor assembly, and it moves a control sleeve inside the pump that regulates the amount of fuel being injected. There is no mechanical connection between the accelerator pedal and the electronically controlled injection pump. Instead, a sensor connected to the accelerator pedal sends a signal to the MSA that represents the actual position of the accelerator pedal. The MSA uses this input, along with input from other sensors to move the control sleeve to deliver

DESCRIPTION AND OPERATION (Continued)

the appropriate amount of fuel. This system is known as “Drive-By-Wire”

The actual time that the fuel is delivered is very important to the diesel combustion process. The MSA monitors outputs from the engine speed sensor (fly-wheel position in degrees), and the fuel injector sensor (mechanical movement within the #1 cylinder fuel injector). Outputs from the Accelerator Pedal Position sensor, engine speed sensor (engine rpm) and engine coolant temperature sensor are also used. The MSA will then compare its set values to these outputs to electrically adjust the amount of fuel timing (amount of advance) within the injection pump. This is referred to as “Closed Loop” operation. The MSA monitors fuel timing by comparing its set value to when the injector #1 opens. If the value is greater than a preset value a fault will be set.

Actual electric fuel timing (amount of advance) is accomplished by the fuel timing solenoid mounted to the bottom of the injection pump (Fig. 5). Fuel timing will be adjusted by the MSA, which controls the fuel timing solenoid.

An overflow valve is attached into the fuel return line at the rear of the fuel injection pump (Fig. 4). This valve serves two purposes. One is to ensure that a certain amount of residual pressure is maintained within the pump when the engine is switched off. The other purpose is to allow excess fuel to be returned to the fuel tank through the fuel return line. The pressure values within this valve are preset and can not be adjusted.

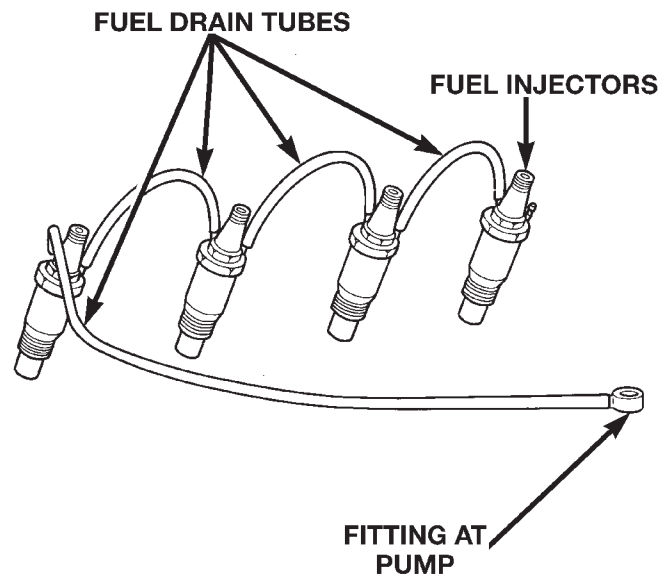
The fuel injection pump supplies high-pressure fuel of approximately 45,000 kPa (6526 psi) to each injector in precise metered amounts at the correct time.

For mechanical injection pump timing, refer to Fuel Injection Pump Timing in the Service Procedures section of this group.

FUEL INJECTORS

Fuel drain tubes (Fig. 6) are used to route excess fuel back to the overflow valve (Fig. 4) at the rear of the injection pump. This excess fuel is then returned to the fuel tank through the fuel return line.

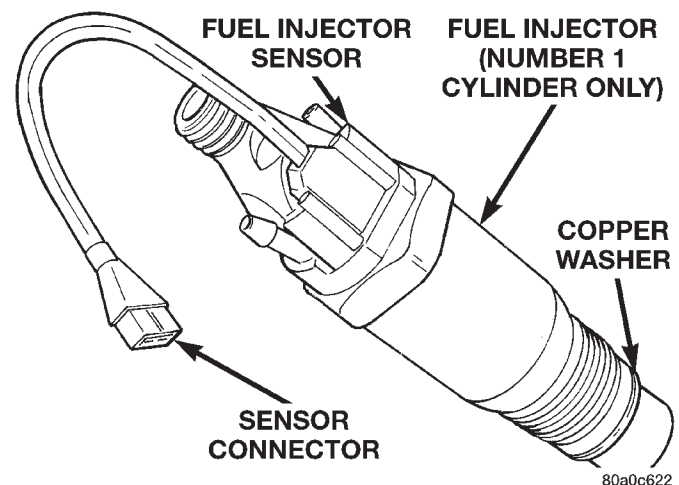
The injectors are connected to the fuel injection pump by the high-pressure fuel lines. A separate injector is used for each of the four cylinders. An injector containing a sensor (Fig. 7) is used on the cylinder number one injector. This injector is called instrumented injector #1 or needle movement sensor. It is used to tell the MSA when the #1 injector's internal spring-loaded valve seat has been forced open by pressurized fuel being delivered to the cylinder, which is at the end of its compression stroke. When the instrumented injector's valve seat is force open, it sends a small voltage spike pulse to the



80a0c625

Fig. 6 Fuel Injectors and Drain Tubes

MSA. This tells the MSA that cylinder #1 is firing. It is not used with the other three injectors.



80a0c622

Fig. 7 Fuel Injector Sensor

Fuel enters the injector at the fuel inlet (top of injector) and is routed to the needle valve bore. When fuel pressure rises to approximately 15,000–15,800 kPa (2175–2291 psi), the needle valve spring tension is overcome. The needle valve rises and fuel flows through the spray holes in the nozzle tip into the combustion chamber. The pressure required to lift the needle valve is the injector opening pressure setting. This is referred to as the “pop-off” pressure setting.

Fuel pressure in the injector circuit decreases after injection. The injector needle valve is immediately closed by the needle valve spring and fuel flow into

DESCRIPTION AND OPERATION (Continued)

the combustion chamber is stopped. Exhaust gases are prevented from entering the injector nozzle by the needle valve.

A copper washer (gasket) is used at the base of each injector (Fig. 7) to prevent combustion gases from escaping.

Fuel injector firing sequence is 1-3-4-2.

FUEL TUBES/LINES/HOSES AND CLAMPS—LOW-PRESSURE TYPE

Also refer to the proceeding section on Quick-Connect Fittings.

Inspect all hose connections such as clamps, couplings and fittings to make sure they are secure and leaks are not present. The component should be replaced immediately if there is any evidence of degradation that could result in failure.

Never attempt to repair a plastic fuel line/tube or a quick-connect fitting. Replace complete line/tube as necessary.

Avoid contact of any fuel tubes/hoses with other vehicle components that could cause abrasions or scuffing. Be sure that the fuel lines/tubes are properly routed to prevent pinching and to avoid heat sources.

The lines/tubes/hoses are of a special construction. If it is necessary to replace these lines/tubes/hoses, use only original equipment type.

The hose clamps used to secure the rubber hoses are of a special rolled edge construction. This construction is used to prevent the edge of the clamp from cutting into the hose. Only these rolled edge type clamps may be used in this system. All other types of clamps may cut into the hoses and cause fuel leaks.

Where a rubber hose is joined to a metal tube (staked), do not attempt to repair. Replace entire line/tube assembly.

Use new original equipment type hose clamps. Tighten hose clamps to 2 N·m (20 in. lbs.) torque.

QUICK-CONNECT FITTINGS—LOW PRESSURE TYPE

Different types of quick-connect fittings are used to attach various fuel system components. These are: a single-tab type, a two-tab type or a plastic retainer ring type (Fig. 8). Refer to Quick-Connect Fittings in the Removal/Installation section for more information.

CAUTION: The interior components (o-rings, spacers) of quick-connect fitting are not serviced separately, but new pull tabs are available for some types. Do not attempt to repair damaged fittings or fuel lines/tubes. If repair is necessary, replace the complete fuel tube assembly.

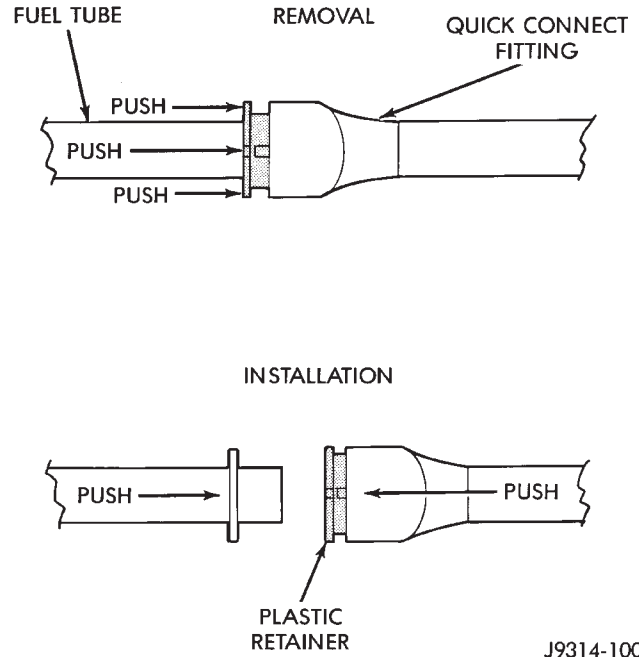


Fig. 8 Plastic Retainer Ring-Type Fitting

HIGH-PRESSURE FUEL LINES

CAUTION: The high-pressure fuel lines must be held securely in place in their holders. The lines cannot contact each other or other components. Do not attempt to weld high-pressure fuel lines or to repair lines that are damaged. Only use the recommended lines when replacement of high-pressure fuel line is necessary.

High-pressure fuel lines deliver fuel under pressure of up to approximately 45,000 kPa (6526 PSI) from the injection pump to the fuel injectors. The lines expand and contract from the high-pressure fuel pulses generated during the injection process. All high-pressure fuel lines are of the same length and inside diameter. Correct high-pressure fuel line usage and installation is critical to smooth engine operation.

WARNING: USE EXTREME CAUTION WHEN INSPECTING FOR HIGH-PRESSURE FUEL LEAKS. INSPECT FOR HIGH-PRESSURE FUEL LEAKS WITH A SHEET OF CARDBOARD. HIGH FUEL INJECTION PRESSURE CAN CAUSE PERSONAL INJURY IF CONTACT IS MADE WITH THE SKIN.

FUEL DRAIN TUBES

These rubber tubes are low-pressure type.

Some excess fuel is continually vented from the fuel injection pump. During injection, a small amount of fuel flows past the injector nozzle and is not injected into the combustion chamber. This fuel

DESCRIPTION AND OPERATION (Continued)

drains into the fuel drain tubes (Fig. 9) and back to the tee banjo fitting, which is connected to the same line as the overflow valve, which allows a variable quantity to return to the fuel tank. The overflow valve is calibrated to open at a preset pressure. Excess fuel not required by the pump to maintain the minimum pump cavity pressure is then returned through the overflow valve and on to the fuel tank through the fuel return line.

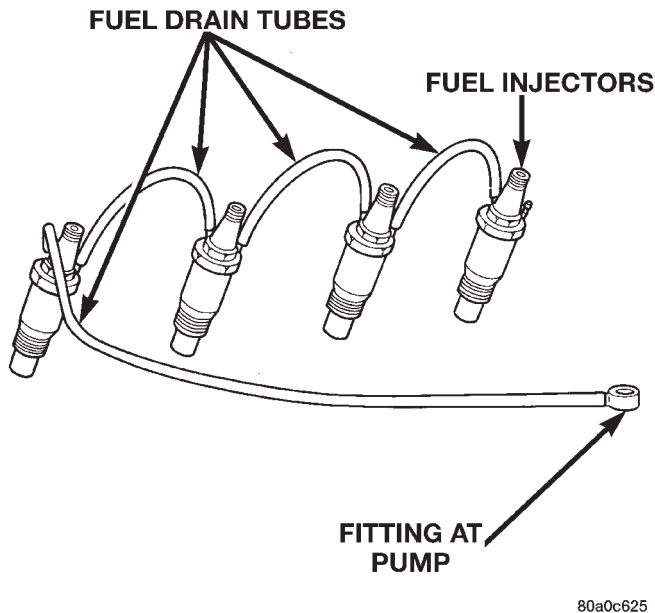


Fig. 9 Fuel Drain Tubes

FUEL HEATER

The fuel heater is used to prevent diesel fuel from waxing during cold weather operation. The fuel heater is located in the bottom plastic bowl of the fuel filter/water separator (Fig. 10).

The element inside the heater assembly is made of a Positive Temperature Coefficient (PTC) material, and has power applied to it by the fuel heater relay anytime the ignition key is in the "on" position. PTC material has a high resistance to current flow when its temperature is high, which means that it will not generate heat when the temperature is above a certain value. When the temperature is below 7°C (45° F), the resistance of the PTC element is lowered, and allows current to flow through the fuel heater element warming the fuel. When the temperature is above 29°C (85° F), the PTC element's resistance rises, and current flow through the heater element stops.

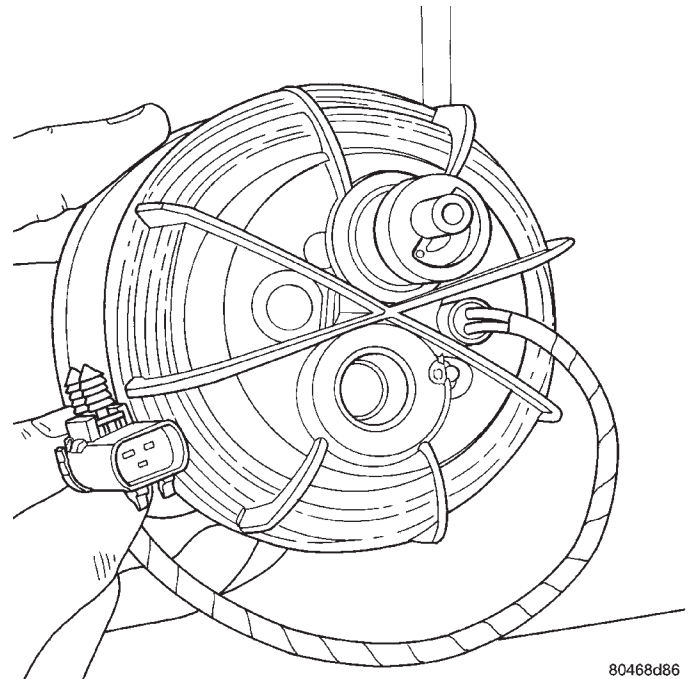


Fig. 10 Fuel Heater Temperature Sensor and Element Location

Voltage to operate the fuel heater is supplied from the ignition (key) switch and through the fuel heater relay. Refer to the following Fuel Heater Relay for additional information. **The fuel heater and fuel heater relay are not controlled by the Powertrain Control Module (PCM).**

Current draw for the heater element is 150 watts at 14 volts (DC).

FUEL HEATER RELAY

Voltage to operate the fuel heater is supplied from the ignition (key) switch through the fuel heater relay. **The PCM or MSA is not used to control this relay.**

The fuel heater relay is located in the PDC. The PDC is located next to the battery in the engine compartment (Fig. 11). For the location of the relay within the PDC, refer to label on PDC cover.

WASTEGATE (TURBOCHARGER)

Refer to Group 11, Exhaust System and Intake Manifold for information.

DESCRIPTION AND OPERATION (Continued)

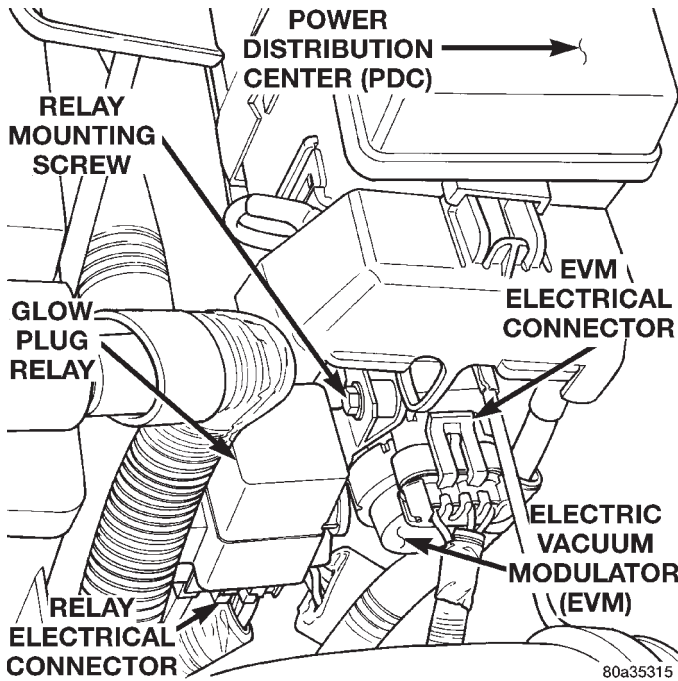


Fig. 11 Relay Location

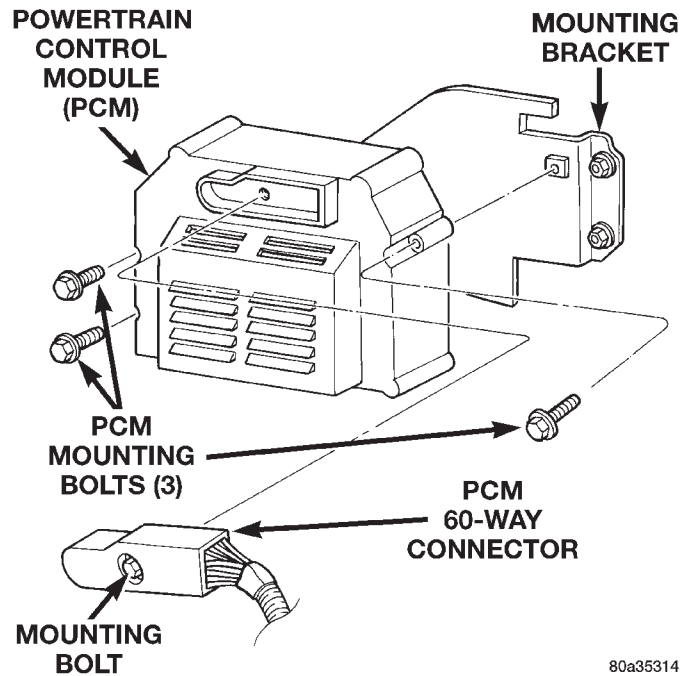


Fig. 12 PCM Location—Typical

DIAGNOSIS AND TESTING

GENERAL INFORMATION

This section of the group will cover a general diagnosis of diesel engine fuel system components.

Diagnostic Trouble Codes: Refer to On-Board Diagnostics in Group 25, Emission Control System for a list of Diagnostic Trouble Codes (DTC's) for certain fuel system components.

The PCM and MSA must be tested with the DRBIII scan tool. The DRBIII should be the first step in any diagnosis of engine performance complaints. Refer to the 1997 ZJ/ZG 2.5L Diesel Powertrain Diagnostic Procedures manual for diagnosis and testing of the diesel engine control system.

VISUAL INSPECTION

A visual inspection for loose, disconnected, or incorrectly routed wires and hoses should be made before attempting to diagnose or service the diesel fuel injection system. A visual check will help find these conditions. It also saves unnecessary test and diagnostic time. A thorough visual inspection of the fuel injection system includes the following checks:

- (1) Be sure that the battery connections are tight and not corroded.
- (2) Be sure that the 60 way connector is fully engaged with the PCM (Fig. 12).
- (3) Be sure that the 68 way connector is fully engaged with the MSA (Fig. 13).

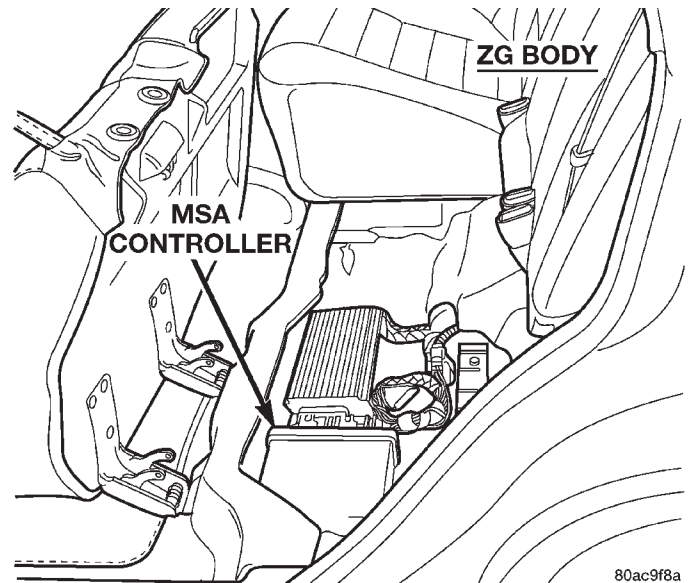


Fig. 13 MSA Location—Typical

(4) Verify that the electrical connections for the ASD relay are clean and free of corrosion. This relay is located in the PDC. For the location of the relay within the PDC, refer to label on PDC cover.

(5) Verify that the electrical connections for the fuel heater relay are clean and free of corrosion. This relay is located in the PDC. For the location of the relay within the PDC, refer to label on PDC cover.

DIAGNOSIS AND TESTING (Continued)

(6) Be sure the electrical connectors at the ends of the glow plugs (Fig. 14) are tight and free of corrosion.

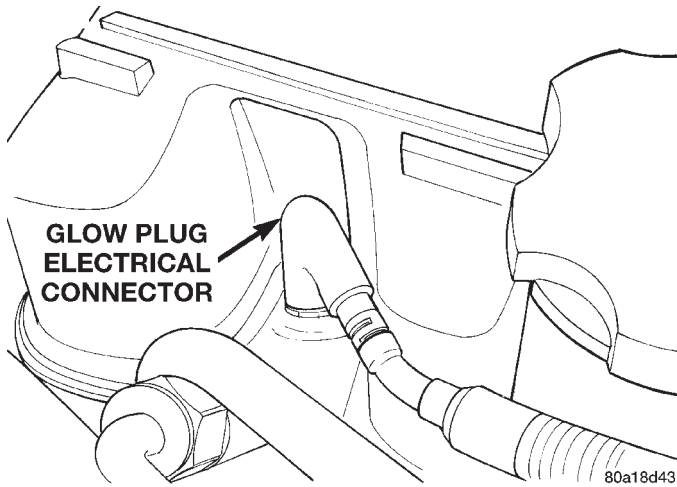


Fig. 14 Glow Plug Connector

(7) Be sure that the electrical connections at the glow plug relay are tight and not corroded. The glow plug relay is located in the engine compartment on the left-*inner* fender (Fig. 15).

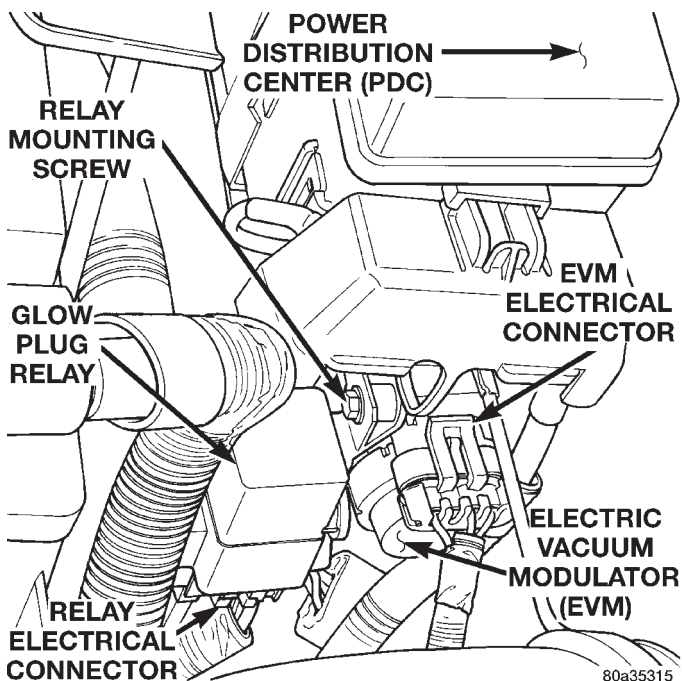


Fig. 15 Glow Plug Relay Location

(8) Inspect the starter motor and starter solenoid connections for tightness and corrosion.

(9) Verify that the Fuel Injection Pump electrical connector is firmly connected. Inspect the connector for corrosion or damaged wires. The solenoid is mounted to the rear of the injection pump (Fig. 16).

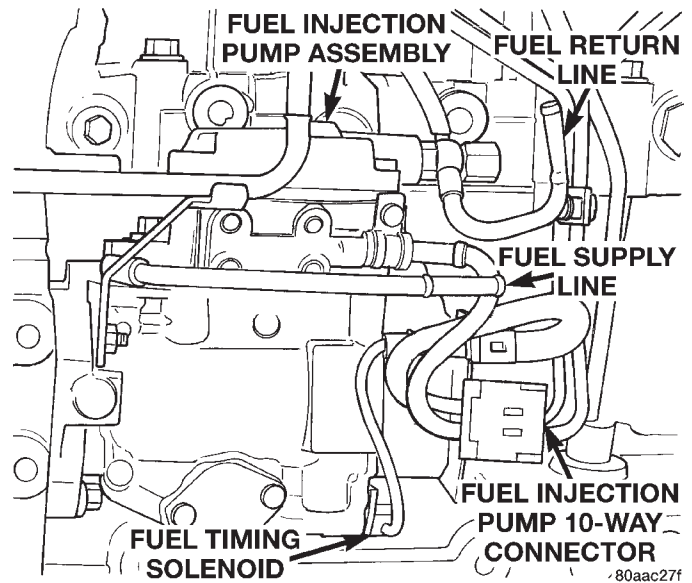


Fig. 16 Fuel Shutdown Solenoid Location

(10) Verify that the fuel heater electrical connector is firmly attached to the filter bowl at the bottom of the fuel filter/water separator. Inspect the connector for corrosion or damaged wires.

(11) Verify that the electrical pigtail connector (sensor connector) (Fig. 17) for the fuel injector sensor is firmly connected to the engine wiring harness. Inspect the connector for corrosion or damaged wires. This sensor is used on the #1 cylinder injector only.

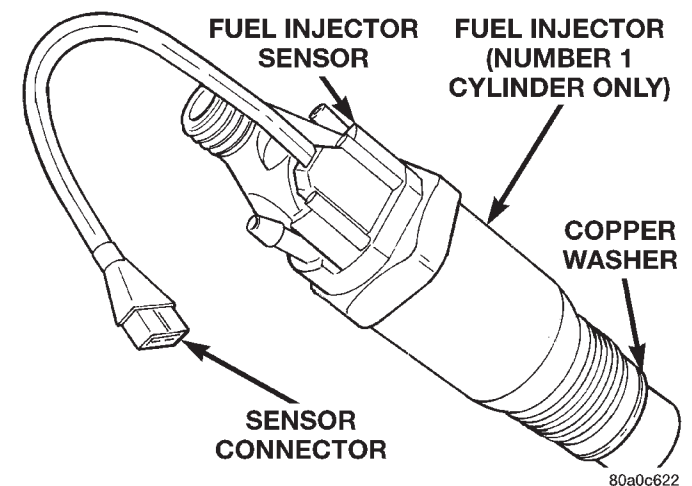
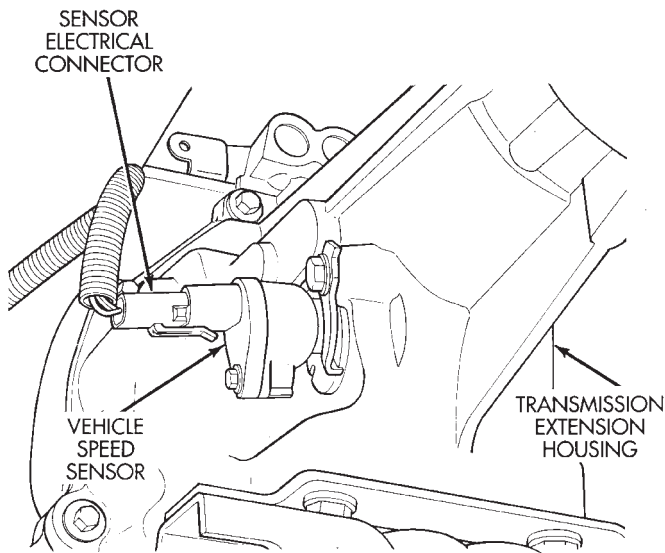


Fig. 17 Fuel Injector Sensor

(12) Inspect for exhaust system restrictions such as pinched exhaust pipes or a collapsed or plugged muffler.

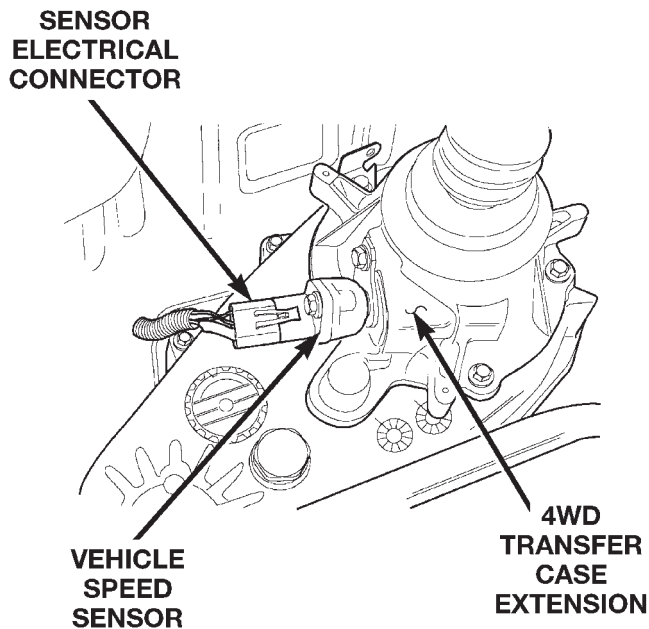
DIAGNOSIS AND TESTING (Continued)

(13) Verify that the harness connector is firmly connected to the vehicle speed sensor (Fig. 18) or (Fig. 19).



J9414-60

Fig. 18 Vehicle Speed Sensor—2 Wheel Drive



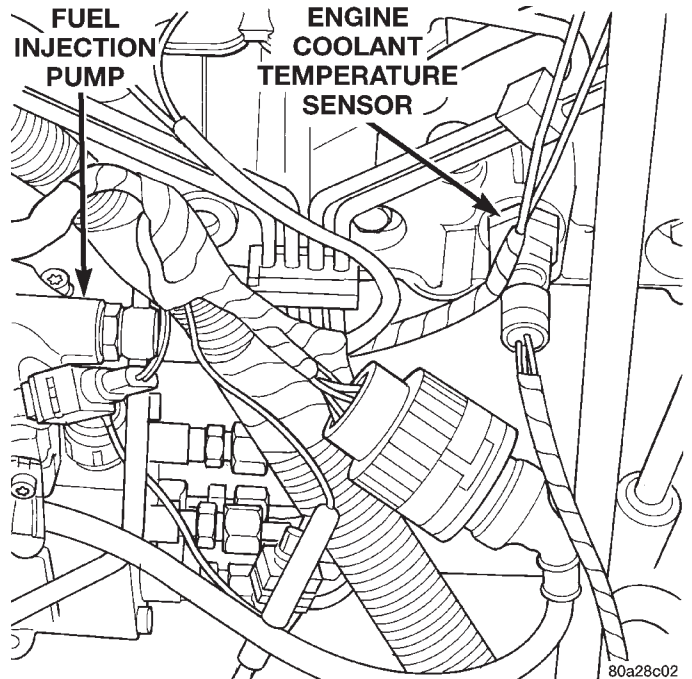
80a35409

Fig. 19 Vehicle Speed Sensor—4 Wheel Drive

(14) Verify turbocharger wastegate operation. Refer to Group 11, Exhaust System and Intake Manifold Group for information.

(15) Verify that the harness connector is firmly connected to the engine coolant temperature sensor.

The sensor is located on the side of cylinder head near the rear of fuel injection pump (Fig. 20).



80a28c02

Fig. 20 Engine Coolant Temperature Sensor Location

(16) Check for air in the fuel system. Refer to the Air Bleed Procedure.

(17) Inspect all fuel supply and return lines for signs of leakage.

(18) Be sure that the ground connections are tight and free of corrosion. Refer to Group 8, Wiring for locations of ground connections.

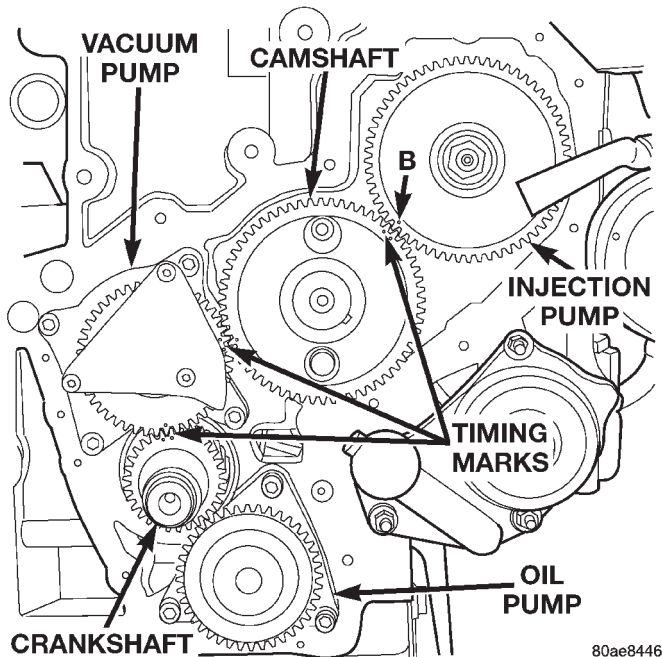
(19) Inspect the air cleaner element (filter) for restrictions.

(20) Be sure that the turbocharger output hose is properly connected to the charge air cooler (inter-cooler) inlet tube. Verify that the charge air cooler output hose is properly connected to the cooler and the intake manifold. Refer to Group 11, Exhaust System and Intake Manifold for information.

(21) Be sure that the vacuum hoses to the vacuum pump are connected and not leaking. It is located at the front of engine (internal) and is over-driven from the crankshaft gear (Fig. 21). Disconnect the hose and check for minimum vacuum from the pump. Refer to Group 5, Brake System for specifications and procedures.

(22) Be sure that the accessory drive belt is not damaged or slipping.

(23) Verify there is a good connection at the engine speed sensor. Refer to the Fuel Injection System in this section for location of the engine speed sensor location.

DIAGNOSIS AND TESTING (Continued)

80ae8446

Fig. 21 Vacuum Pump at Front of Engine

(24) Verify there is a good connection at the Mass Air Flow Sensor, which is a part of the air intake assembly.

AIR IN FUEL SYSTEM

Air will enter the fuel system whenever the fuel supply lines, fuel filter/water separator, fuel filter bowl, injection pump, high-pressure lines or injectors are removed or disconnected. Air will also enter the fuel system whenever the fuel tank has been run empty.

Air trapped in the fuel system can result in hard starting, a rough running engine, engine misfire, low power, excessive smoke and fuel knock. After service is performed, air must be bled from the system before starting the engine.

Inspect the fuel system from the fuel tank to the injectors for loose connections. Leaking fuel is an indicator of loose connections or defective seals. Air can also enter the fuel system between the fuel tank and the injection pump. Inspect the fuel tank and fuel lines for damage that might allow air into the system.

For air bleeding, refer to Air Bleed Procedure in the Service Procedures section of this group.

FUEL HEATER RELAY TEST

The fuel heater relay is located in the Power Distribution Center (PDC). Refer to Relays—Operation/Testing in Fuel Injection System section of this group for test procedures.

FUEL INJECTOR TEST

The fuel injection nozzles, located on the engine cylinder head, spray fuel under high pressure into the individual combustion chambers. Pressurized fuel, delivered by the fuel injection pump, unseats a spring-loaded needle valve inside the injector, and the fuel is atomized as it escapes through the injector opening into the engine's combustion chamber. If the fuel injector does not operate properly, the engine may misfire, or cause other driveability problems.

A leak in the injection pump-to-injector high-pressure fuel line can cause many of the same symptoms as a malfunctioning injector. Inspect for a leak in the high-pressure lines before checking for a malfunctioning fuel injector.

WARNING: THE INJECTION PUMP SUPPLIES HIGH-PRESSURE FUEL OF UP TO APPROXIMATELY 45,000 KPA (6526 PSI) TO EACH INDIVIDUAL INJECTOR THROUGH THE HIGH-PRESSURE LINES. FUEL UNDER THIS AMOUNT OF PRESSURE CAN PENETRATE THE SKIN AND CAUSE PERSONAL INJURY. WEAR SAFETY GOGGLES AND ADEQUATE PROTECTIVE CLOTHING. AVOID CONTACT WITH FUEL SPRAY WHEN BLEEDING HIGH-PRESSURE FUEL LINES.

WARNING: DO NOT BLEED AIR FROM THE FUEL SYSTEM OF A HOT ENGINE. DO NOT ALLOW FUEL TO SPRAY ONTO THE EXHAUST MANIFOLD WHEN BLEEDING AIR FROM THE FUEL SYSTEM.

To determine which fuel injector is malfunctioning, run the engine and loosen the high-pressure fuel line nut at the injector (Fig. 22). Listen for a change in engine speed. If engine speed drops, the injector was operating normally. If engine speed remains the same, the injector may be malfunctioning. After testing, tighten the line nut to 30 N·m (22 ft. lbs.) torque. Test all injectors in the same manner one at a time.

Once an injector has been found to be malfunctioning, remove it from the engine and test it. Refer to the Removal/Installation section of this group for procedures.

After the injector has been removed, install it to a bench-mount injector tester. Refer to operating instructions supplied with tester for procedures.

The opening pressure or "pop" pressure should be 15,000–15,800 kPa (2175–2291 psi). If the fuel injector needle valve is opening ("popping") too early or too late, replace the injector.

DIAGNOSIS AND TESTING (Continued)

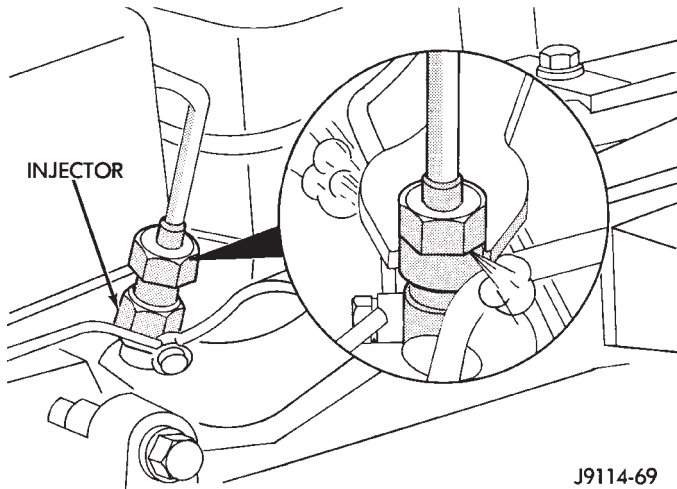


Fig. 22 Typical Inspection of Fuel Injector

FUEL INJECTOR SENSOR TEST

The fuel injector sensor is used only on the fuel injector for the number-1 cylinder (Fig. 23). It is not used on the injectors for cylinders number 2, 3, or 4.

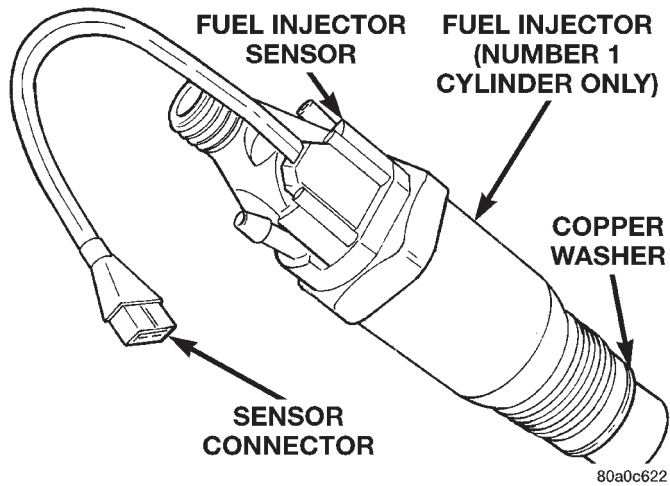


Fig. 23 Fuel Injector Sensor Location

To test the sensor, unplug the sensor connector (Fig. 23) from the engine wiring harness. Check resistance across terminals. Resistance should be 110 ohms ± 10 ohms at 20°C (68°F). Replace sensor if specification cannot be met.

FUEL INJECTION PUMP TEST

The injection pump is not to be serviced or the warranty may be voided. If the injection pump requires service, the complete assembly must be replaced.

Incorrect injection pump timing (mechanical or electrical) can cause poor performance, excessive smoke and emissions and poor fuel economy.

A defective fuel injection pump, defective fuel timing solenoid or misadjusted mechanical pump timing

can cause starting problems or prevent the engine from revving up. It can also cause:

- Engine surge at idle
- Rough idle (warm engine)
- Low power
- Excessive fuel consumption
- Poor performance
- Low power
- Black smoke from the exhaust
- Blue or white fog like exhaust
- Incorrect idle or maximum speed

The electronically controlled fuel pump has no mechanical governor like older mechanically controlled fuel pumps. Do not remove the top cover of the fuel pump, or the screws fastening the wiring pigtail to the side of the pump. **The warranty of the injection pump and the engine may be void if those seals have been removed or tampered with.**

FUEL SUPPLY RESTRICTIONS

LOW-PRESSURE LINES

Restricted or Plugged supply lines or fuel filter can cause a timing fault that will cause the PCM to operate the engine in a "Limp Home" mode. See the introduction of the Fuel Injection System in this group for more information on the Limp Home mode. Fuel supply line restrictions can cause starting problems and prevent the engine from revving up. The starting problems include; low power and blue or white fog like exhaust. Test all fuel supply lines for restrictions or blockage. Flush or replace as necessary. Bleed the fuel system of air once a fuel supply line has been replaced. Refer to the Air Bleed Procedure section of this group for procedures.

HIGH-PRESSURE LINES

Restricted (kinked or bent) high-pressure lines can cause starting problems, poor engine performance and black smoke from exhaust.

Examine all high-pressure lines for any damage. Each radius on each high-pressure line must be smooth and free of any bends or kinks.

Replace damaged, restricted or leaking high-pressure fuel lines with the correct replacement line.

CAUTION: The high-pressure fuel lines must be clamped securely in place in the holders. The lines cannot contact each other or other components. Do not attempt to weld high-pressure fuel lines or to repair lines that are damaged. Only use the recommended lines when replacement of high-pressure fuel line is necessary.

DIAGNOSIS AND TESTING (Continued)**FUEL SHUTDOWN SOLENOID TEST**

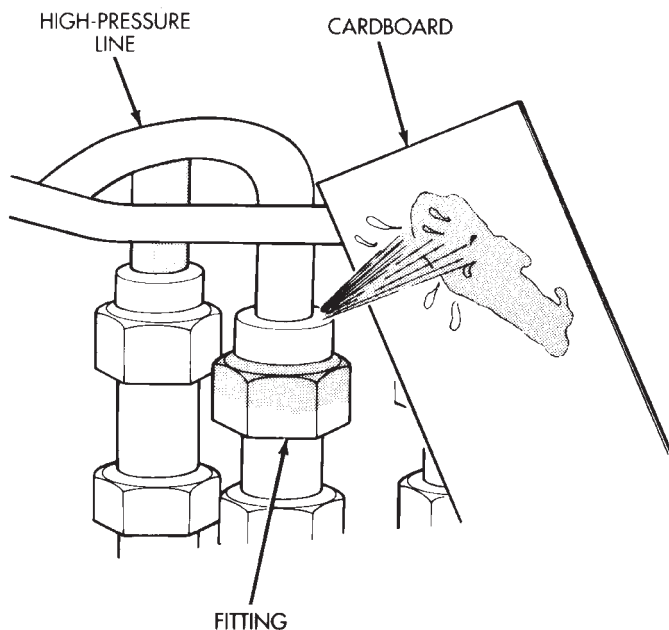
Refer to 1997 ZJ/ZG 2.5L Diesel Powertrain Diagnostic Manual for the Fuel Shutdown Solenoid test.

HIGH-PRESSURE FUEL LINE LEAK TEST

High-pressure fuel line leaks can cause starting problems and poor engine performance.

WARNING: DUE TO EXTREME FUEL PRESSURES OF UP TO 45,000 KPA (6526 PSI), USE EXTREME CAUTION WHEN INSPECTING FOR HIGH-PRESSURE FUEL LEAKS. DO NOT GET YOUR HAND, OR ANY PART OF YOUR BODY NEAR A SUSPECTED LEAK. INSPECT FOR HIGH-PRESSURE FUEL LEAKS WITH A SHEET OF CARDBOARD. HIGH FUEL INJECTION PRESSURE CAN CAUSE PERSONAL INJURY IF CONTACT IS MADE WITH THE SKIN.

Start the engine. Move the cardboard over the high-pressure fuel lines and check for fuel spray onto the cardboard (Fig. 24). If a high-pressure line connection is leaking, bleed the system and tighten the connection. Refer to the Air Bleed Procedure in this group for procedures. Replace damaged, restricted or leaking high-pressure fuel lines with the correct replacement line.



J9414-130

Fig. 24 Typical Test for Leaks with Cardboard

CAUTION: The high-pressure fuel lines must be clamped securely in place in the holders. The lines cannot contact each other or other components. Do not attempt to weld high-pressure fuel lines or to repair lines that are damaged. Only use the recom-

mended lines when replacement of high-pressure fuel line is necessary.

WASTEGATE (TURBOCHARGER)

Refer to Group 11, Exhaust System and Intake Manifold for information.

SERVICE PROCEDURES**AIR BLEED PROCEDURES****AIR BLEEDING AT FUEL FILTER**

A certain amount of air may become trapped in the fuel system when fuel system components are serviced or replaced. Bleed the system as needed after fuel system service according to the following procedures.

WARNING: DO NOT BLEED AIR FROM THE FUEL SYSTEM OF A HOT ENGINE. DO NOT ALLOW FUEL TO SPRAY ONTO THE EXHAUST MANIFOLD WHEN BLEEDING AIR FROM THE FUEL SYSTEM.

Some air enters the fuel system when the fuel filter or injection pump supply line is changed. This small amount of air is vented automatically from the injection pump through the fuel drain manifold tubes if the filter was changed according to instructions. Ensure the bowl of the fuel filter/water separator is full of fuel.

It may be necessary to manually bleed the system if:

- The bowl of the fuel filter/water separator is not partially filled before installation of a new filter
- The injection pump is replaced
- High-pressure fuel line connections are loosened or lines replaced
- Initial engine start-up or start-up after an extended period of no engine operation
- Running fuel tank empty

FUEL INJECTION PUMP BLEEDING

(1) If the fuel injection pump has been replaced, air should be bled at the overflow valve before attempting to start engine.

- (a) Loosen the overflow valve (Fig. 25) at the rear of the injection pump.
- (b) Place a towel below the valve.

WARNING: WHEN CRANKING THE ENGINE TO BLEED AIR FROM THE INJECTION PUMP, THE ENGINE MAY START. PLACE THE TRANSMISSION IN NEUTRAL OR PARK AND SET PARKING BRAKE BEFORE ENGAGING THE STARTER MOTOR.

SERVICE PROCEDURES (Continued)

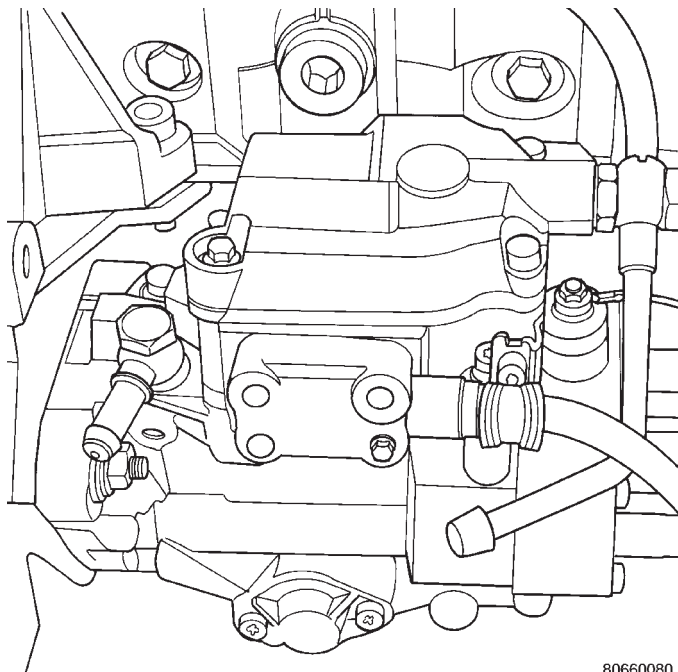


Fig. 25 Overflow Valve

CAUTION: Do not engage the starter motor for more than 30 seconds at a time. Allow 2 minutes between cranking intervals.

(2) Crank the engine for 30 seconds at a time to allow air trapped in the injection pump to vent out the fuel injector drain tubes. Continue this procedure until the engine starts. Observe the previous WARNING and CAUTION.

(3) Tighten overflow valve.

HIGH-PRESSURE FUEL LINE BLEEDING

WARNING: THE INJECTION PUMP SUPPLIES HIGH-PRESSURE FUEL OF APPROXIMATELY 59,000 KPA (8,557 PSI) TO EACH INDIVIDUAL INJECTOR THROUGH THE HIGH-PRESSURE LINES. FUEL UNDER THIS AMOUNT OF PRESSURE CAN PENETRATE THE SKIN AND CAUSE PERSONAL INJURY. WEAR SAFETY GOGGLES AND ADEQUATE PROTECTIVE CLOTHING AND AVOID CONTACT WITH FUEL SPRAY WHEN BLEEDING HIGH-PRESSURE FUEL LINES.

WARNING: DO NOT BLEED AIR FROM THE FUEL SYSTEM OF A HOT ENGINE. DO NOT ALLOW FUEL TO SPRAY ONTO THE EXHAUST MANIFOLD WHEN BLEEDING AIR FROM THE FUEL SYSTEM.

Bleed air from one injector at time.

(1) Loosen the high-pressure fuel line fitting at the injector (Fig. 26).

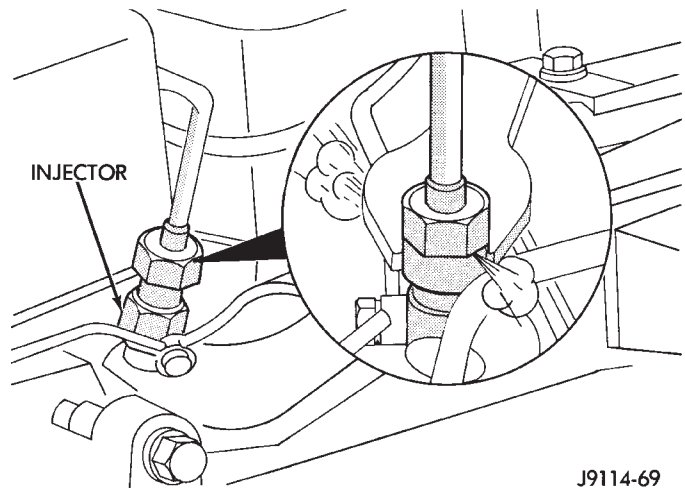


Fig. 26 Bleeding High-Pressure Fuel Line—Typical

(2) Crank the engine until all air has been bled from the line. **Do not operate the starter motor for longer than 30 seconds. Wait 2 minutes between cranking intervals.**

(3) Start the engine and bleed one injector at a time until the engine runs smoothly.

FUEL INJECTION PUMP TIMING

Refer to Removal/Installation and Adjusting Fuel Pump Timing in this Group.

REMOVAL AND INSTALLATION

ACCELERATOR PEDAL

REMOVAL

- (1) Disconnect electrical connector.
- (2) Remove accelerator pedal mounting bracket nuts. Remove accelerator pedal assembly.

INSTALLATION

- (1) Place accelerator pedal assembly over studs protruding from floor pan. Tighten mounting nuts to 5 N·m (46 in. lbs.) torque.
- (2) Connect electrical connector.
- (3) Before starting the engine, operate the accelerator pedal to check for any binding.

AIR CLEANER ELEMENT

REMOVAL

- (1) Remove hose clamp at Mass Air Flow Sensor.
- (2) Remove hose from Mass Air Flow Sensor.
- (3) Loosen 2 clamps holding air cleaner housing halves together.
- (4) Remove left side of air cleaner housing.
- (5) Remove element from air cleaner housing.

REMOVAL AND INSTALLATION (Continued)

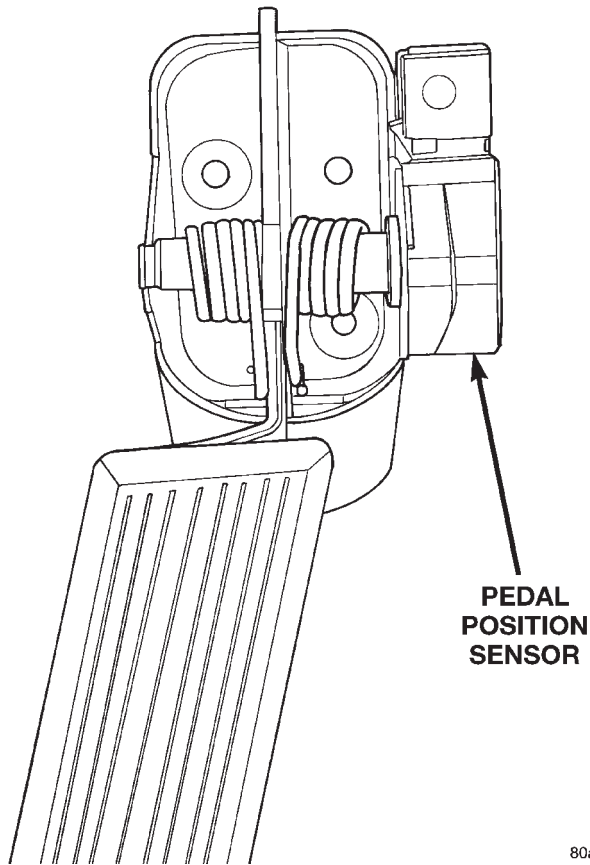


Fig. 27 Accelerator Pedal Mounting-Typical

INSTALLATION

- (1) Install a new element in housing.
- (2) Position left side of housing.
- (3) Snap clamps into place.
- (4) Install hoses and clamps.

FUEL DRAIN TUBES

The fuel drain tubes (Fig. 28) are low-pressure type.

Pull each tube from the injector for removal. Push on for installation. Clamps are not required for these tubes.

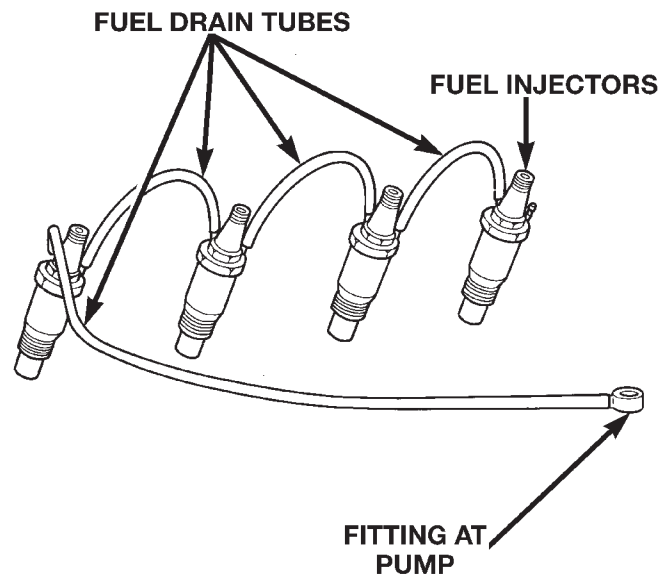
FUEL FILTER/WATER SEPARATOR

The fuel filter/water separator is located in the engine compartment on the left side near the shock tower. (Fig. 29).

The fuel filter/water separator assembly contains the fuel filter, fuel heater element, and fuel drain valve (Fig. 29).

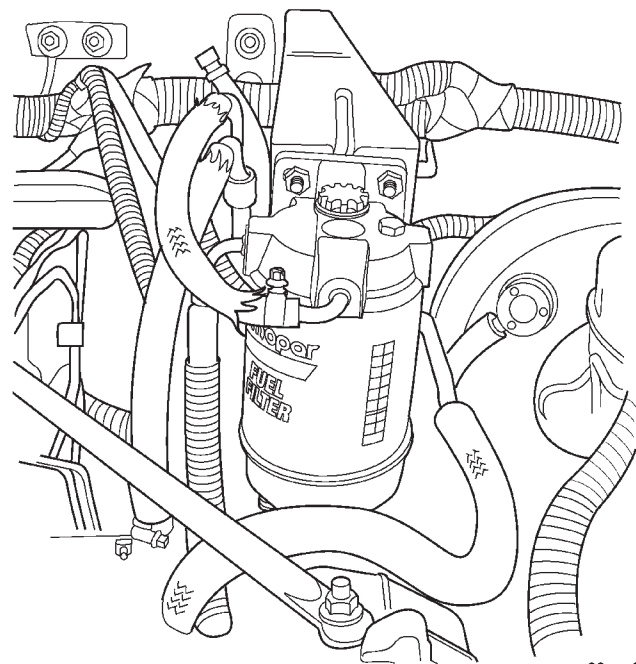
DRAINING WATER FROM FILTER BOWL

Moisture (water) collects at the bottom of the filter/separator in a plastic bowl. Water entering the fuel injection pump can cause serious damage to the pump. **Note that the bulb will be illuminated for approximately 2 seconds each time the key is**



80a0c625

Fig. 28 Fuel Drain Tubes



80ace65e

Fig. 29 Fuel Filter/Water Separator Location initially placed in the ON position. This is done for a bulb check.

WARNING: DO NOT ATTEMPT TO DRAIN WATER FROM THE FILTER/SEPARATOR WITH THE ENGINE HOT.

- (1) The bottom of the filter/separator bowl is equipped with a drain valve (Fig. 29). The drain valve is equipped with a fitting. Attach a piece of

REMOVAL AND INSTALLATION (Continued)

rubber hose to this fitting. This hose is to be used as a drain hose.

- (2) Place a drain pan under the drain hose.
- (3) With the engine not running, open the drain valve (unscrew—drain valve has right hand threads) from the filter/separator bowl. To gain access to this fitting, the two filter-to-mounting bracket nuts (Fig. 29) may have to be loosened a few turns.
- (4) Hold the drain open until clean fuel exits the drain.
- (5) After draining, close drain valve.
- (6) Remove rubber drain hose.
- (7) Dispose of mixture in drain pan according to applicable local or federal regulations.

FUEL FILTER REMOVAL

- (1) Drain all fuel and/or water from fuel filter/water separator assembly. Refer to the previous Draining Water From Filter Bowl.
- (2) Unplug the electrical connectors at bottom of plastic bowl.
- (3) Remove plastic bowl from bottom of fuel filter (unscrews).
- (4) Remove fuel filter from bottom of filter base (unscrews).

FUEL FILTER INSTALLATION

- (1) Clean bottom of fuel filter base.
- (2) Apply clean diesel fuel to new fuel filter gasket.
- (3) Install and tighten filter to filter base. The beveled part of the rubber gasket should be facing up towards the filter base.
- (4) Clean the inside of bowl with a soap and water mixture before installation. Carefully clean any residue between the two metal probes at the top of the water-in-fuel sensor. Do not use chemical cleaners as damage to the plastic bowl may result.
- (5) Pour diesel fuel into the plastic bowl before installing bowl to bottom of fuel filter. Do this to help prevent air from entering fuel injection pump while attempting to starting engine.
- (6) Install filter bowl to bottom of filter.
- (7) Install the electrical connectors at bottom of bowl.
- (8) Tighten the filter-to-mounting bracket nuts (Fig. 29) to 28 N·m (250 in. lbs.) torque.

FUEL HEATER

If the fuel heater element needs replacement, the plastic filter bowl assembly must be replaced. Refer to Fuel Filter/Water Separator for information.

FUEL HEATER RELAY

The fuel heater relay is located in the PDC. For the location of the relay within the PDC (Fig. 30), refer to label on PDC cover.

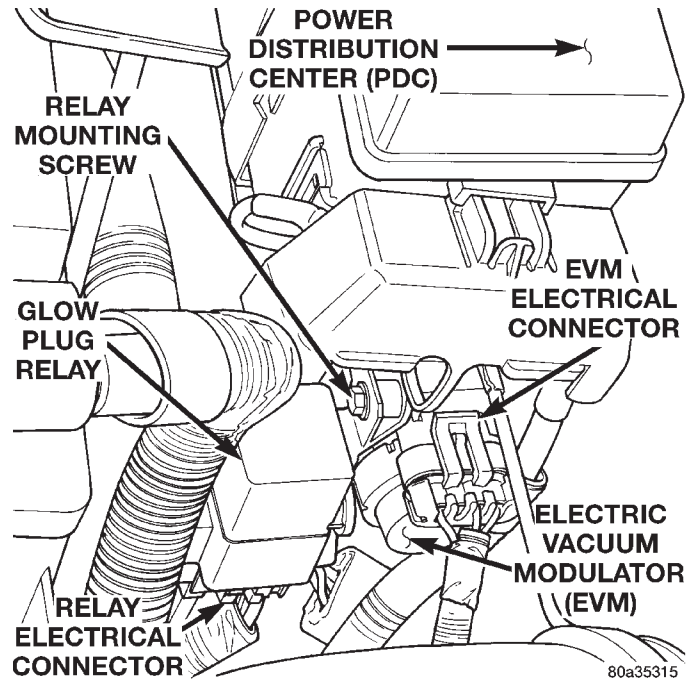


Fig. 30 Power Distribution Center (PDC) Location

FUEL LEVEL SENSOR

The fuel level sensor is located on the side of the fuel pump module.(Fig. 31)

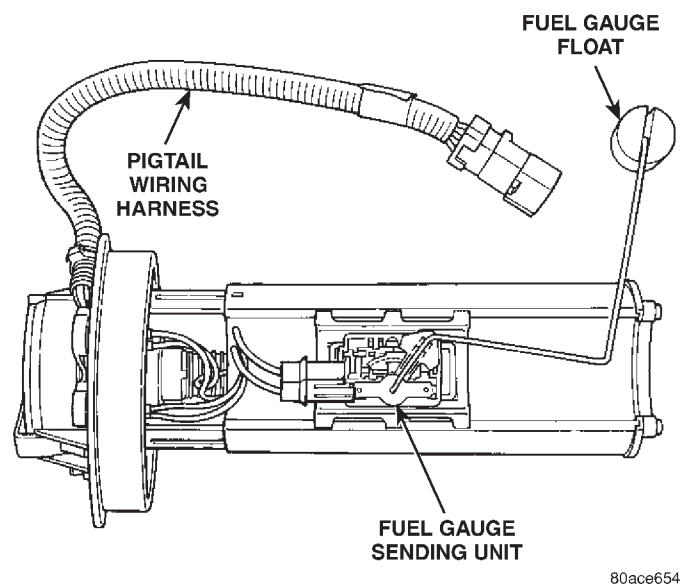
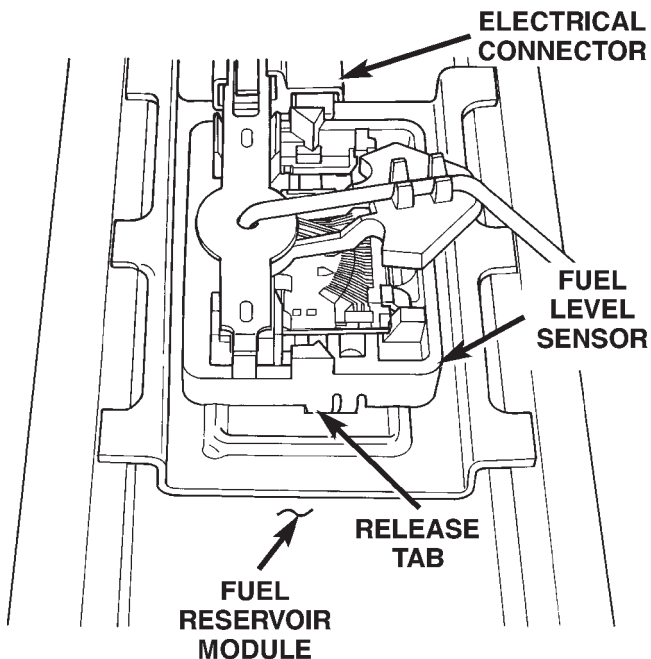


Fig. 31 Fuel Level Sensor

REMOVAL

- (1) Remove fuel tank. Refer to Fuel Tank Removal/Installation.
- (2) Remove fuel pump module. Refer to Fuel Pump Module Removal/Installation.
- (3) Remove electrical wire connector at sending unit terminals.
- (4) Press on release tab(Fig. 32) to remove sending unit from pump module.

REMOVAL AND INSTALLATION (Continued)



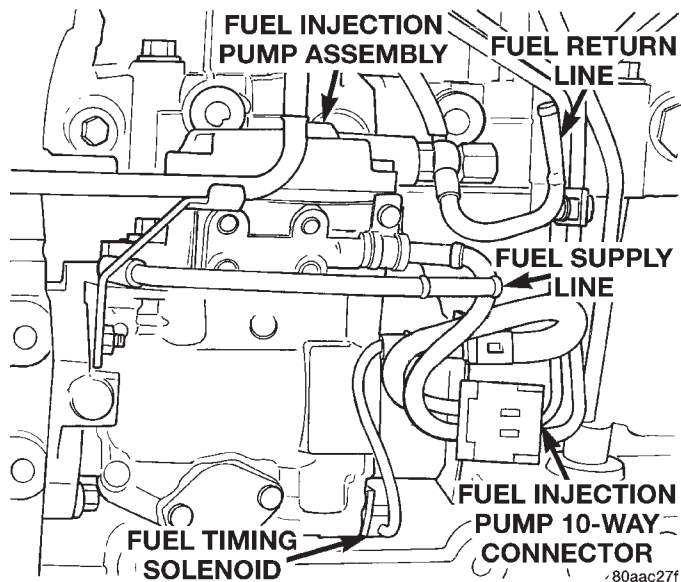
80ad090e

Fig. 32 Fuel Level Sensor Release Tab

FUEL INJECTION PUMP

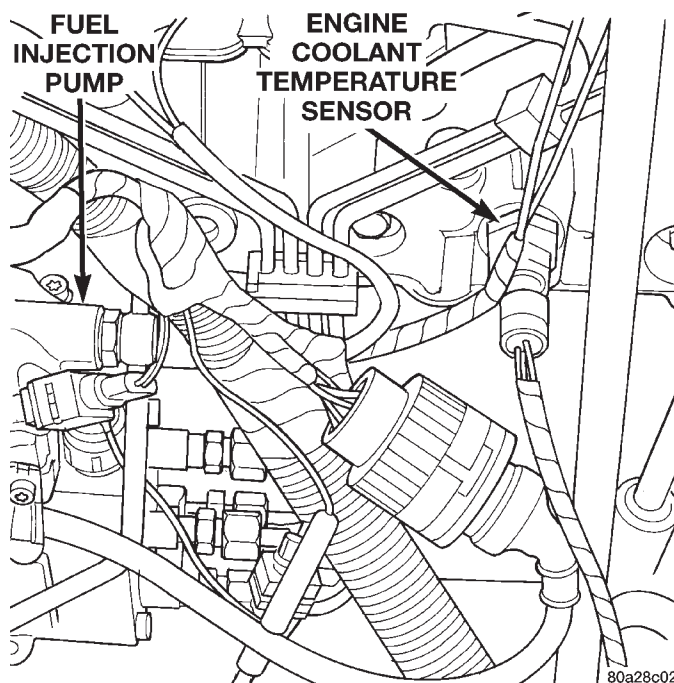
REMOVAL

- (1) Disconnect negative battery cable at battery.
- (2) Thoroughly clean the area around the injection pump and fuel lines of all dirt, grease and other contaminants. **Due to the close internal tolerances of the injection pump, this step must be performed before removing pump.**
- (3) Remove the engine accessory drive belt. Refer to Group 7, Cooling System for procedures.
- (4) Remove the generator assembly.
- (5) Remove the rubber fuel return and supply hoses from metal lines at pump (Fig. 33).
- (6) Remove the electrical connector at engine coolant temperature sensor (Fig. 34).
- (7) Disconnect the Fuel Injection Pump electrical connector at fuel pump. (Fig. 33).
- (8) Disconnect the main engine wiring harness from the glow plugs.
- (9) Disconnect the four high-pressure fuel lines from the fuel injection pump. Also disconnect fuel lines at the fuel injectors. For procedures, refer to High-Pressure Fuel Lines in this group. Place a rag beneath the fittings to catch excess fuel.
- (10) Remove plug from timing gear cover.
- (11) The "Top Dead Center" (TDC) compression firing stroke must be determined as follows:
 - (a) Remove the valve cover, refer to Group 9, Valve Cover Removal/Installation.
 - (b) Remove the right front tire and splash shield. Using a socket attached to the end of crank-



80aac27f

Fig. 33 Overflow Valve and Fuel Shutdown Solenoid



80a28c02

Fig. 34 Engine Coolant Temperature Sensor

shaft, rotate the engine (counter-clockwise as viewed from front).

(c) Rotate the engine until cylinder #4 rockers are in between movement.

(d) Remove rocker arm assembly.

(e) Remove valve spring and keepers. **CAUTION: When the piston is at TDC there is only 2 mm (.080 thousand) clearance between the valve and piston.**

(f) Let the valve set on top of piston. Install a dial indicator to the top of the valve stem.

REMOVAL AND INSTALLATION (Continued)

(g) Rotate engine back and forth to find the TDC position with the indicator on the valve stem. Mark the damper and timing cover for TDC.

NOTE: On later model 1997 engines, a hole in the bottom of the clutch housing can be lined up with a hole in the flywheel, allowing the engine to be held at TDC with a special alignment tool, part # VM1035.

(12) Remove injection pump drive gear nut (Fig. 35) and washer. **CAUTION:** Be very careful not to drop the washer into the timing gear cover.

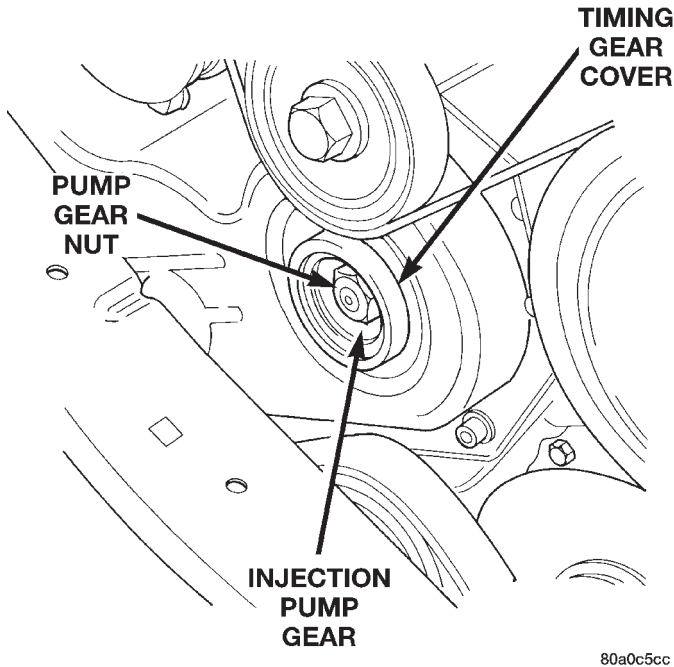


Fig. 35 Removing Pump Drive Gear Nut

(13) A special 3-piece gear removal tool set VM.1003 (Fig. 36) must be used to remove the injection pump drive gear from the pump shaft.

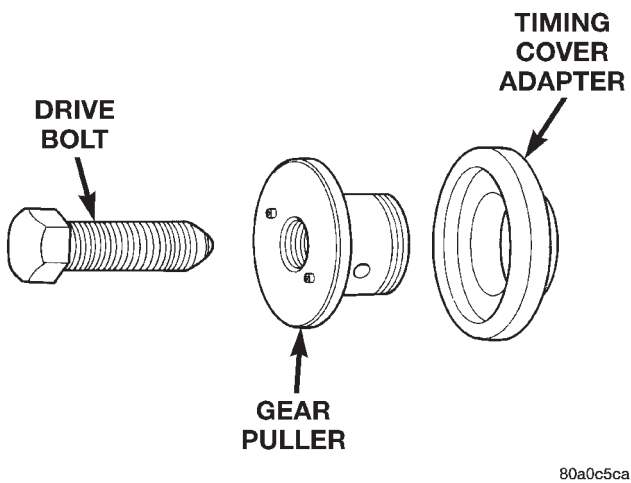


Fig. 36 Pump Gear Tools

(a) Thread the adapter (Fig. 37) into the timing cover.

(b) Thread the gear puller into the injection pump drive gear (Fig. 37). This tool is also used to hold the gear in synchronization during pump removal.

(c) Remove the three injection pump-to-gear cover mounting nuts (Fig. 38). **CAUTION:** This step must be done to prevent breakage of the three injection pump mounting flanges while gear is being removed.

(d) Install the drive bolt into the gear puller (Fig. 37). Tighten the drive bolt to press (remove) the drive gear from injection pump shaft while driving injection pump rearward from timing gear cover mounting studs.

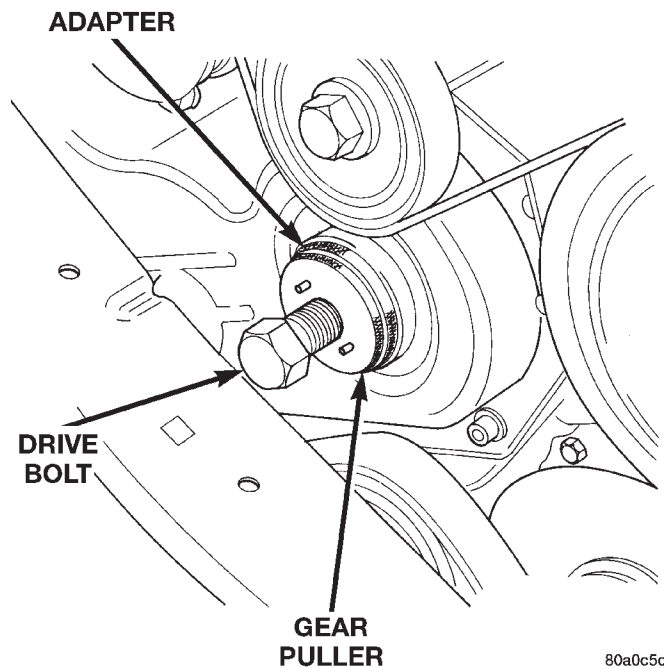


Fig. 37 Installing Pump Drive Gear Removal Tools

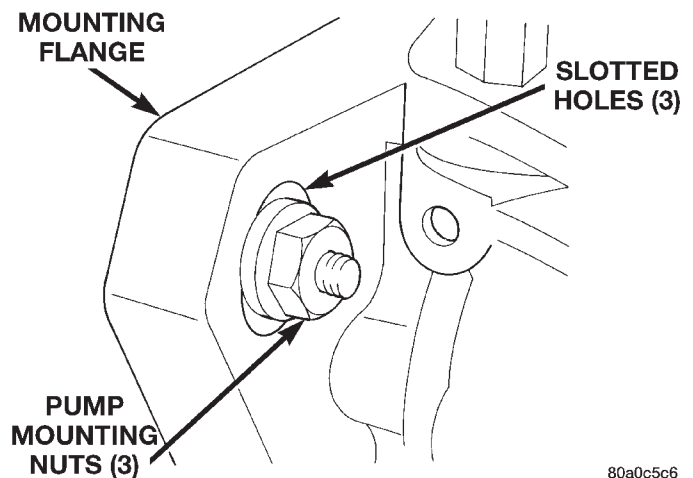


Fig. 38 Injection Pump Mounting Nuts

REMOVAL AND INSTALLATION (Continued)

(14) Remove pump from engine. **Do not rotate engine while gear puller is installed. Engine damage will occur.**

INSTALLATION/ADJUSTING PUMP TIMING

(1) Clean the mating surfaces of injection pump and timing gear cover.

(2) Install a new injection pump-to-timing gear cover gasket.

(3) Remove the gear removing bolt (drive bolt) from gear puller. **CAUTION: Do not remove the special gear puller or timing cover adapter tools from timing cover at this time. Gear misalignment will result.**

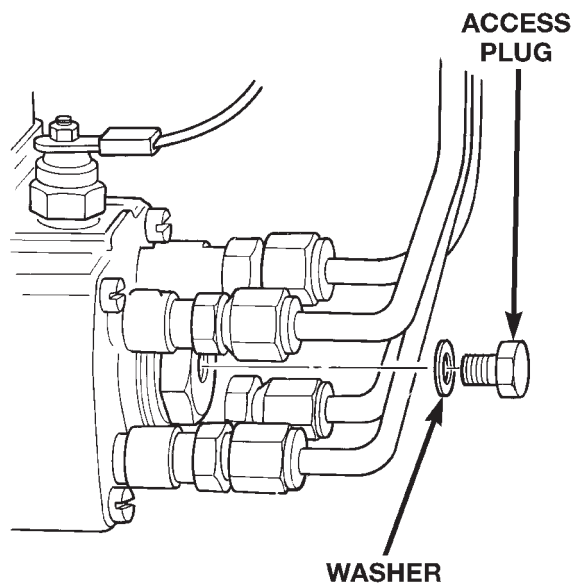
(4) Place the key way on the pump shaft to the 11 o'clock position as viewed from the front of pump. Install the pump into the rear of timing gear cover while aligning key way on pump shaft into pump gear.

(5) Install and snug the 3 injection pump mounting nuts. This is not the final tightening sequence.

(6) Remove the special gear puller and adapter tools from timing gear cover.

(7) Install the injection pump drive gear nut and washer. Tighten nut to 88 N·m (65 ft. lbs.) torque.

(8) Remove access plug and plug washer at rear of pump (Fig. 39). Thread special dial indicator adapter tool VM.1011 (Fig. 40) into this opening. Hand tighten only.

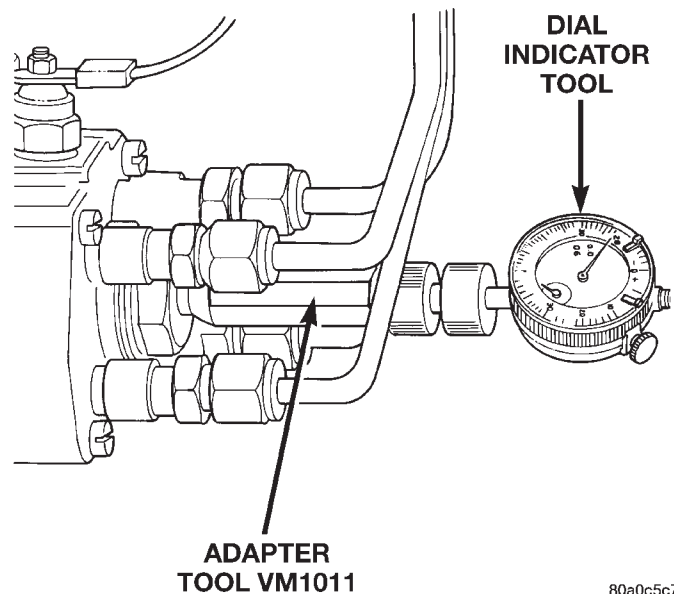


80a0c5c8

Fig. 39 Access Plug at Rear of Pump

(9) Attach special dial indicator tool VM.1013 into the adapter tool (Fig. 40).

(10) Using a socket attached to the end of crankshaft, rotate the engine (counter-clockwise as



80a0c5c7

Fig. 40 Installing Dial Indicator and Special Adapter Tools

viewed from front) until the dial indicator stops moving. This rotation is about 20° to 30°.

(11) Set the dial indicator to 0 mm. Be sure the tip of dial indicator is touching the tip inside the adapter tool.

(12) Very slowly rotate the crankshaft clockwise until movement on dial indicator needle has stopped. **Do not rotate crankshaft after needle movement has stopped. Engine should be at TDC at this point**

(13) Check the TDC dial indicator for TDC.

(14) Gauge reading should be at 0.60 mm. If not, the pump must be rotated for adjustment:

(a) Loosen the three injection pump mounting nuts at the mounting flanges. These flanges are equipped with slotted holes. The slotted holes are used to rotate and position the injection pump for fuel timing. Loosen the three nuts just enough to rotate the pump.

(b) Rotate the pump **clockwise** (as viewed from front) until .60 mm is indicated on the dial indicator gauge.

(c) Tighten the three pump mounting nuts to 30 N·m (22 ft. lbs.) torque.

(d) Recheck the dial indicator after tightening the pump mounting nuts. Gauge should still be reading 0.60 mm. Loosen pump mounting nuts and readjust if necessary.

(15) Remove dial indicator and adapter tools.

(16) Install access plug and washer to rear of injection pump.

(17) Install plug at timing gear cover.

REMOVAL AND INSTALLATION (Continued)

- (18) Remove dial indicator from valve stem.
- (19) Install valve spring and keepers.
- (20) Install rocker arm assembly and tighten nuts.
- (21) Install and connect the four high-pressure fuel lines to the fuel injection pump. Also connect fuel lines at the fuel injectors. For procedures, refer to High-Pressure Fuel Lines in this group.
- (22) Install electrical connector at engine coolant temperature sensor.
- (23) Connect electrical connector at fuel shutdown solenoid.
- (24) Connect the main engine wiring harness to the glow plugs.
- (25) Connect the fuel timing solenoid pigtail harness to the engine wiring harness.
- (26) Connect the overflow valve/banjo fitting (fuel return line assembly). Replace copper gaskets before installing.
- (27) Connect the rubber fuel return and supply hoses to metal lines at pump. Tighten hose clamps to 2 N-m (20 in. lbs.) torque.
- (28) Install generator assembly.
- (29) Install engine accessory drive belt. Refer to Group 7, Cooling System for procedures.
- (30) Install negative battery cable to battery.
- (31) Start the engine and bring to normal operating temperature.
- (32) Check for fuel leaks.

FUEL INJECTORS

Four fuel injectors are used on each engine. Of these four, two different types are used. The fuel injector used on cylinder number one is equipped with a fuel injector sensor (Fig. 41). The other three fuel injectors are identical. **Do not place the fuel injector equipped with the fuel injector sensor into any other location except the cylinder number one position.**

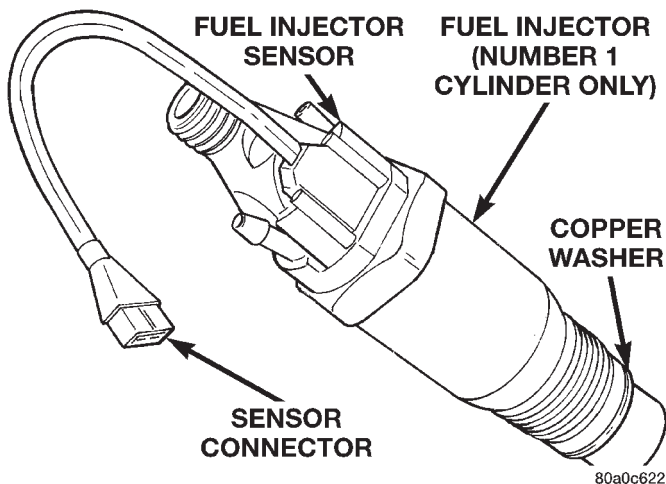


Fig. 41 Fuel Injector Sensor—Number-1 Cylinder

REMOVAL

- (1) Disconnect negative battery cable at battery.
- (2) Thoroughly clean the area around the injector with compressed air.
- (3) Remove the fuel drain hoses (tubes) at each injector (Fig. 42) being serviced. Each of these hoses is slip-fit to the fitting on injector.

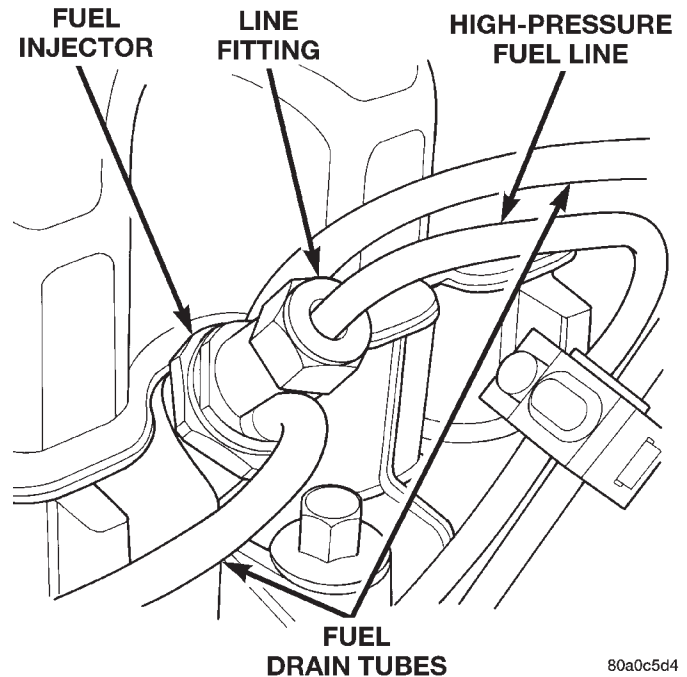


Fig. 42 Fuel Injector—Typical

- (4) Remove the high-pressure fuel line at injector being removed. Refer to High-Pressure Fuel Lines in this group for procedures.
- (5) Remove the injector using special socket tool number VM.1012A. When removing cylinder number one injector, thread the wiring harness through the access hole on the special socket (Fig. 43).

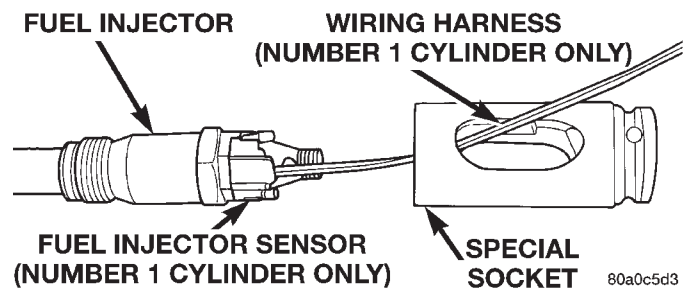


Fig. 43 Wiring Harness Through Socket

- (6) Remove and discard the copper washer (seal) at bottom of injector (Fig. 41).

INSTALLATION

- (1) Clean the injector threads in cylinder head.
- (2) Install new copper washer (seal) to injector.

REMOVAL AND INSTALLATION (Continued)

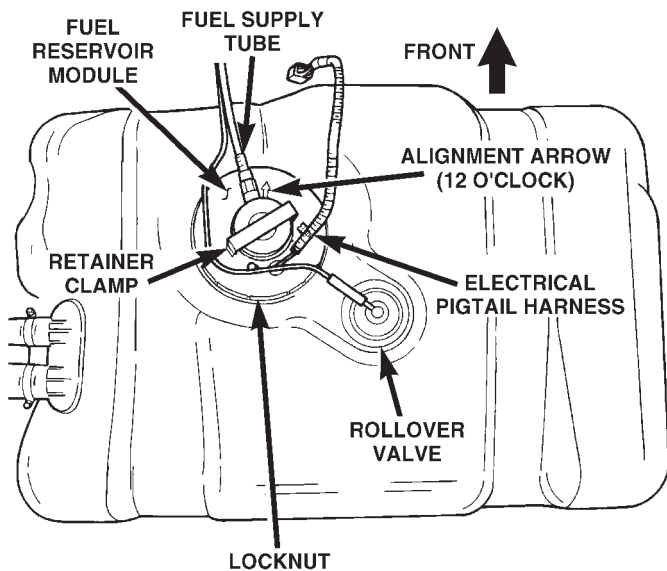
(3) Install injector to engine. Tighten to 70 N·m (52 ft. lbs.) torque.

(4) Install high-pressure fuel lines. Refer to High-Pressure Fuel Lines in this group for procedures.

(5) Install fuel drain hoses (tubes) to each injector. Do not use clamps at fuel drain hoses.

(6) Connect negative battery cable to battery.

(7) Bleed the air from the high-pressure lines. Refer to the Air Bleed Procedure section of this group.

FUEL TANK

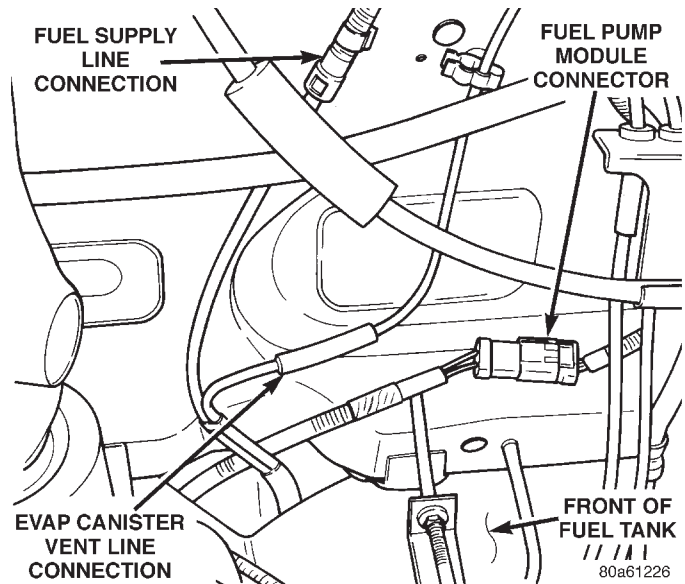
80ad090c

Fuel Tank**REMOVAL**

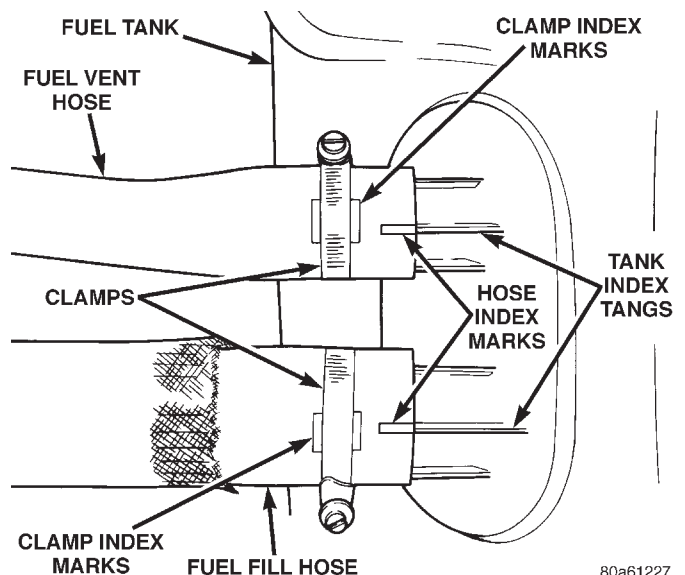
- (1) Disconnect negative cable from battery.
- (2) Insert fuel siphon hose into fuel filler neck and push it into the tank.
- (3) Drain fuel tank dry into holding tank or a properly labeled **diesel** safety container.
- (4) Raise vehicle on hoist.
- (5) Disconnect both the fuel fill and fuel vent rubber hoses at the fuel tank.
- (6) Disconnect fuel supply and return lines from the steel supply line (Fig. 44).

The fuel reservoir module electrical connector has a retainer that locks it in place.

- (7) Slide electrical connector lock to unlock.
- (8) Push down on connector retainer (Fig. 46) and pull connector off module.
- (9) Use a transmission jack to support fuel tank. Remove bolts from fuel tank straps.
- (10) Lower tank slightly. Carefully remove filler hose from tank.



80a61226

Fig. 44 Fuel Tank Connections at Front of Tank

80a61227

Fig. 45 Fuel Fill/Vent Hose Index Marks

- (11) Lower the fuel tank. Remove clamp and remove fuel filler tube vent hose. Remove fuel tank from vehicle.

INSTALLATION

- (1) Position fuel tank on transmission jack. Connect fuel filler tube vent hose and replace clamp.
- (2) Raise tank into position and carefully work filler tube into tank. A light coating of clean engine oil on the tube end may be used to aid assembly.
- (3) Feed filler vent line thru frame rail. Careful not to cross lines.
- (4) Tighten strap bolts to 54 N·m (40 ft. lbs.) torque. Remove transmission jack.

REMOVAL AND INSTALLATION (Continued)

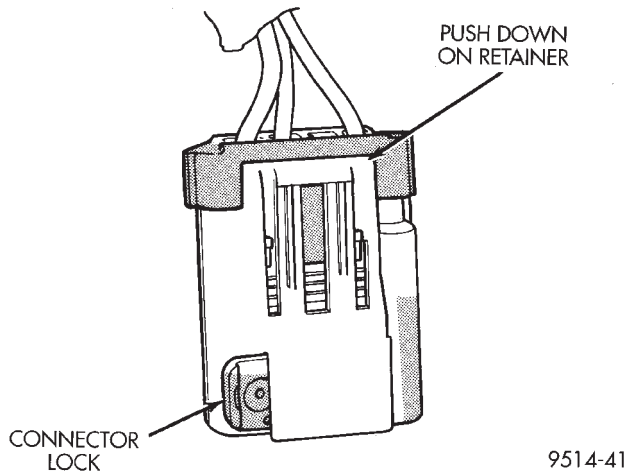


Fig. 46 Module Connector Retainer and Lock

CAUTION: Ensure straps are not twisted or bent before or after tightening strap nuts.

- (5) Connect module electrical connector. Place retainer in locked position.
- (6) Lubricate the fuel supply and return lines with clean 30 weight engine oil, install the quick connect fuel fitting. Refer to Tube/Fitting Assembly in the Fuel Delivery section of this Group.
- (7) Attach filler line to filler tube. Pull on connector to make sure of connection.
- (8) Fill fuel tank, replace cap, and connect battery negative cable.

FUEL RESERVOIR MODULE

REMOVAL

WARNING: THE FUEL RESERVOIR OF THE FUEL MODULE DOES NOT EMPTY OUT WHEN THE TANK IS DRAINED. THE FUEL IN THE RESERVOIR WILL SPILL OUT WHEN THE MODULE IS REMOVED.

- (1) Disconnect negative cable from battery.
- (2) Drain fuel tank dry into holding tank or a properly labeled **diesel** safety container.
- (3) Raise vehicle on hoist.
- (4) Use a transmission jack to support the fuel tank. Remove bolts from fuel tank straps. Lower tank slightly.
- (5) Clean area around fuel reservoir module and tank to keep dirt and foreign material out of tank.
- (6) Disconnect fuel lines from fuel module by depressing quick connect retainers with thumb and fore finger.
- (7) Slide module electrical connector lock to unlock.
- (8) Push down on connector retainer and pull connector off module.

- (9) Using Special Tool 6856, remove plastic locknut counterclockwise to release pump module (Fig. 47).

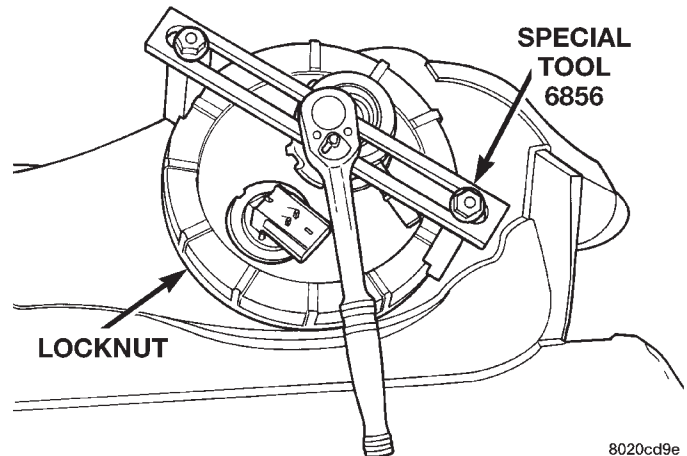


Fig. 47 Fuel Reservoir Module Lock Nut Removal

- (10) Carefully remove module and O-ring from tank.
- (11) Discard old O-ring.

INSTALLATION

- (1) Wipe seal area of tank clean and place a new O-ring seal in position on pump.
- (2) Position fuel reservoir module in tank with locknut.
- (3) Tighten locknut to 58 N·m (43 ft. lbs.).
- (4) Connect fuel lines.
- (5) Plug in electrical connector. Slide connector lock into position.
- (6) Raise fuel tank, install bolts into fuel tank straps and tighten.
- (7) Lower vehicle on hoist.
- (8) Connect negative cable from battery.
- (9) Fill fuel tank. Check for leaks.
- (10) Install fuel filler cap.

HIGH-PRESSURE LINES

All high-pressure fuel lines are of the same length and inside diameter. Correct high-pressure fuel line usage and installation is critical to smooth engine operation.

CAUTION: The high-pressure fuel lines must be clamped securely in place in the holders. The lines cannot contact each other or other components. Do not attempt to weld high-pressure fuel lines or to repair lines that are damaged. Only use the recommended lines when replacement of high-pressure fuel line is necessary.

REMOVAL

- (1) Disconnect negative battery cable from battery.

REMOVAL AND INSTALLATION (Continued)

(2) Remove the necessary clamps (Fig. 48) holding the lines to the engine.

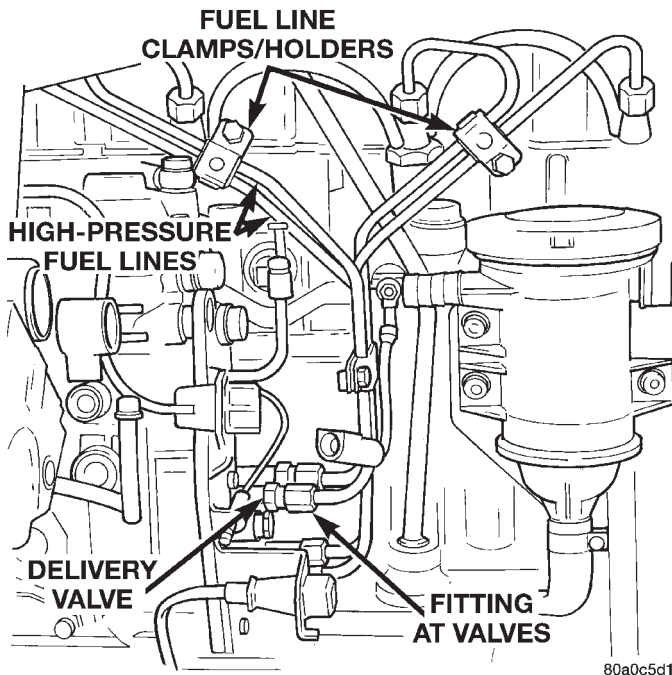


Fig. 48 Fuel Lines and Clamps/holders

(3) Clean the area around each fuel line connection. Disconnect each line at the top of each fuel injector (Fig. 49).

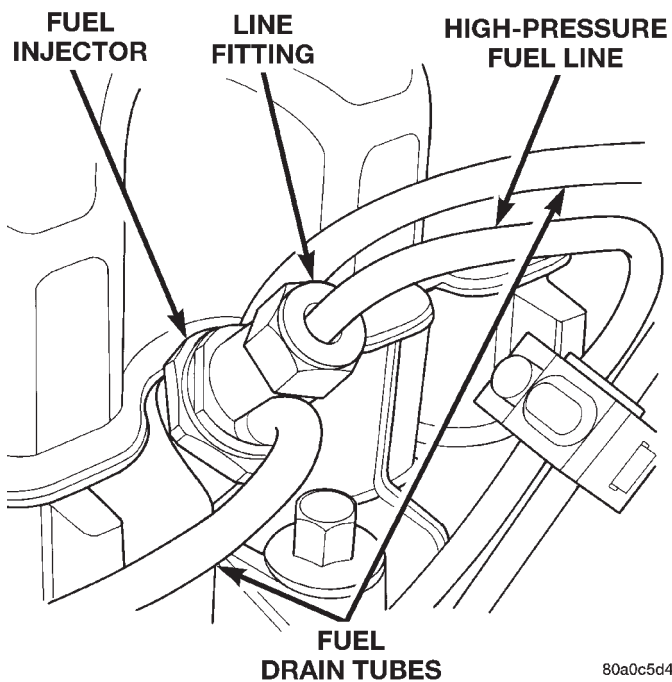


Fig. 49 Fuel Lines at Fuel Injectors

(4) Disconnect each high-pressure line fitting at each fuel injection pump delivery valve.

(5) Very carefully remove each line from the engine. Note the position (firing order) of each line while removing. **Do not bend the line while removing.**

CAUTION: Be sure that the high-pressure fuel lines are installed in the same order that they were removed. Prevent the injection pump delivery valve holders (Fig. 48) from turning when removing or installing high-pressure lines from injection pump.

INSTALLATION

(1) Carefully position each high-pressure fuel line to the fuel injector and fuel injection pump delivery valve holder in the correct firing order. Also position each line in the correct line holder.

(2) Loosely install the line clamp/holder bolts.

(3) Tighten each line at the delivery valve to 30 N·m (22 ft. lbs.) torque.

(4) Tighten each line at the fuel injector to 30 N·m (22 ft. lbs.) torque.

Be sure the lines are not contacting each other or any other component.

(5) Tighten the clamp bracket bolts to 24 N·m (18 ft. lbs.) torque.

(6) Bleed air from the fuel system. Refer to the Air Bleed Procedure section of this group.

SPECIFICATIONS**FUEL TANK CAPACITY**

75 Liters (20.0 Gals.)

Nominal refill capacities are shown. A variation may be observed from vehicle to vehicle due to manufacturing tolerances, ambient temperatures and refill procedures.

IDLE SPEED

900 rpm ±25 rpm with engine at normal operating temperature.

FUEL INJECTOR FIRING SEQUENCE

1-3-4-2

FUEL SYSTEM PRESSURE

Peak Injection Pressure/Fuel Injection Pump Operating Pressure: 40,000–45,000 kPa (5801–6526 psi).

Opening Pressure of Fuel Injector: 15,000–15,800 kPa (2175–2291 psi).

FUEL INJECTION SYSTEM—2.5L DIESEL ENGINE

INDEX

	page		page
GENERAL INFORMATION			
INTRODUCTION	25	POWERTRAIN CONTROL MODULE (PCM)	26
DESCRIPTION AND OPERATION			
AIR CONDITIONING (A/C) CONTROLS—MSA		SENSOR RETURN—MSA/PCM INPUT	
INPUTS	28	(ANALOG GROUND)	27
AIR CONDITIONING RELAY—MSA OUTPUT ...	30	SPEED CONTROL—MSA INPUT	29
ASD RELAY—MSA INPUT	30	SPEED CONTROL—PCM OUTPUTS	30
BATTERY VOLTAGE—PCM INPUT	27	TACHOMETER—PCM OUTPUT	31
BRAKE SWITCH—MSA INPUT	29	VEHICLE SPEED SENSOR—MSA INPUT	29
DATA LINK CONNECTOR—PCM AND MSA		VEHICLE THEFT ALARM	27
INPUT AND OUTPUT	29	DIAGNOSIS AND TESTING	
ELECTRIC VACUUM MODULATOR (EVM)—MSA		ASD RELAY TEST	32
OUTPUT	32	DIAGNOSTIC TROUBLE CODES	35
ENGINE COOLANT GAUGE—PCM OUTPUT ...	30	DIESEL DIAGNOSTICS	32
ENGINE COOLANT TEMPERATURE SENSOR—		ENGINE COOLANT TEMPERATURE SENSOR	
MSA/PCM INPUT	28	TEST	32
ENGINE OIL PRESSURE GAUGE—PCM		ENGINE SPEED SENSOR TEST	32
OUTPUT	30	GLOW PLUG RELAY TEST	33
ENGINE SPEED/CRANK POSITION SENSOR—		GLOW PLUG TEST	33
MSA INPUT	28	MASS AIR FLOW SENSOR	35
FIVE VOLT POWER—MSA/PCM OUTPUT	30	RELAYS—OPERATION/TESTING	34
FUEL INJECTOR SENSOR—GROUND	28	VEHICLE SPEED SENSOR TEST	35
FUEL TIMING SOLENOID—MSA OUTPUT	30	REMOVAL AND INSTALLATION	
GLOW PLUG LAMP—PCM OUTPUT	30	A/C CLUTCH RELAY	35
GLOW PLUG RELAY—MSA OUTPUT	31	ASD RELAY	35
GLOW PLUGS	31	ENGINE COOLANT TEMPERATURE SENSOR ..	36
IGNITION CIRCUIT SENSE—MSA/PCM INPUT .	27	ENGINE SPEED SENSOR	35
IGNITION CIRCUIT SENSE—PCM INPUT	27	GLOW PLUG RELAY	37
MASS AIR FLOW SENSOR	27	GLOW PLUGS	36
NEEDLE MOVEMENT OR INSTRUMENTED		POWERTRAIN CONTROL MODULE (PCM)	37
FIRST INJECTOR—MSA INPUT	27	VEHICLE SPEED SENSOR	37
POWER GROUND	27	SPECIFICATIONS	
		GLOW PLUG CURRENT DRAW	38
		TORQUE CHART—2.5L DIESEL	39

GENERAL INFORMATION

INTRODUCTION

This section will cover components either regulated or controlled by the MSA controller and the Powertrain Control Module (PCM). The fuel heater relay and fuel heater are not operated by the MSA controller or the PCM. These components are controlled by the ignition (key) switch. All other fuel system electrical components necessary to operate the engine are controlled or regulated by the MSA controller, which interfaces with the PCM. Refer to the following description for more information.

Certain fuel system component failures may cause a no start, or prevent the engine from running. It is important to know that the MSA has a feature

where, if possible, it will ignore the failed sensor, set a code related to the sensor, and operate the engine in a "Limp Home" mode. When the MSA is operating in a "Limp Home" mode, the Check Engine Lamp on the instrument panel may be constantly illuminated, and the engine will most likely have a noticeable loss of performance. An example of this would be an Accelerator Pedal Position Sensor failure, and in that situation, the engine would run at a constant 1100 RPM, regardless of the actual position of the pedal. This is the most extreme of the three "Limp Home" modes.

When the Check Engine Lamp is illuminated constantly with the key on and the engine running,, it usually indicates a problem has been detected somewhere within the fuel system. The DRBIII scan tool

GENERAL INFORMATION (Continued)

is the best method for communicating with the MSA and PCM to diagnose faults within the system.

DESCRIPTION AND OPERATION

POWERTRAIN CONTROL MODULE (PCM)

The MSA controller is mounted under the left side rear seat (Fig. 1). The Powertrain Control Module (PCM) is mounted in the engine compartment. (Fig. 2).

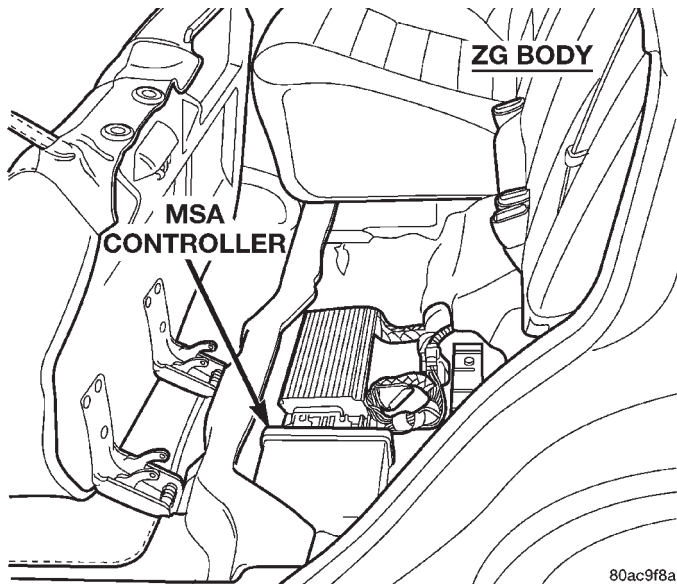


Fig. 1 MSA Controller Location

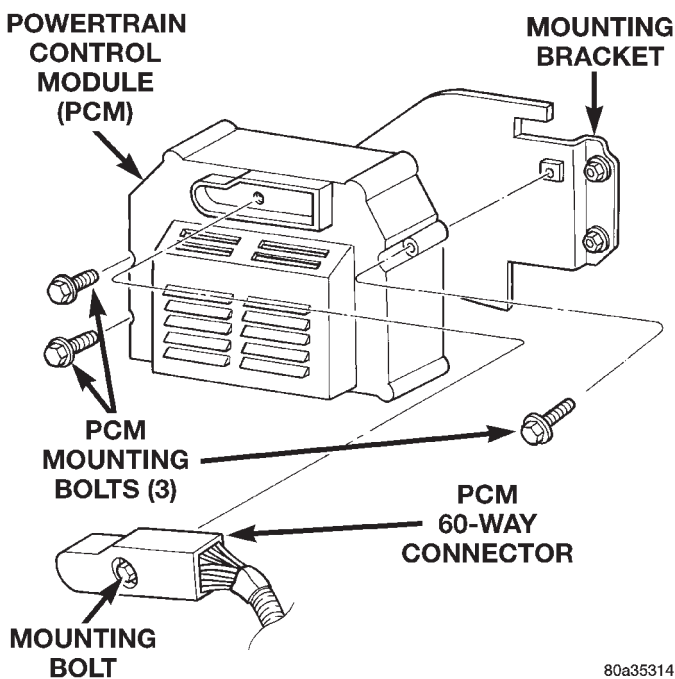


Fig. 2 PCM Location

The MSA Controller is a pre-programmed, digital computer. It will either directly operate or partially regulate the:

- Speed Control
- Speed Control lamp
- Fuel Timing Solenoid
- Check Engine Light
- Glow Plug Relay
- Glow Plugs
- Glow Plug Lamp
- ASD Relay
- Air Conditioning
- Tachometer
- Electric Vacuum Modulator (EVM)

The MSA can adapt its programming to meet changing operating conditions.

The MSA receives input signals from various switches and sensors. Based on these inputs, the MSA regulates various engine and vehicle operations through different system components. These components are referred to as **MSA Outputs**. The sensors and switches that provide inputs to the MSA are considered **MSA Inputs**.

MSA Inputs are:

- Air Conditioning Selection
- Theft Alarm
- ASD Relay
- Control Sleeve Position Sensor
- Fuel Temperature Sensor
- Mass Air Flow Sensor
- Accelerator Pedal Position Sensor
- Engine Coolant Temperature Sensor
- Low Idle Position Switch
- 5 Volt Supply
- Vehicle Speed Sensor
- Engine Speed/Crank Position Sensor (rpm)
- Needle Movement Sensor
- Starter Signal
- Brake Switch
- Speed Control Switch
- Power Ground
- Ignition (key) Switch Sense

MSA Outputs:

After inputs are received by the MSA and PCM, certain sensors, switches and components are controlled or regulated by the MSA and PCM. These are considered **MSA Outputs**. These outputs are for:

- A/C Clutch Relay (for A/C clutch operation)
- Speed Control Lamp
- ASD Relay
- 5 Volts Supply
- Fuel Quantity Actuator
- Fuel Timing Solenoid
- Fuel Shutdown Solenoid
- Glow Plug Lamp
- Check Engine Lamp ("On/Off" signal)

DESCRIPTION AND OPERATION (Continued)

- Electric Vacuum Modulator (EVM)
- Glow Plug Relay
- Tachometer

The PCM sends and receives signals to and from the MSA controller. **PCM inputs are:**

- Power Ground
- 5 Volts Supply
- Vehicle Speed Sensor
- Water-In-Fuel Sensor
- Coolant Temperature Sensor
- Low Coolant Sensor
- Sensor Return
- Fuel Level Sensor
- Oil Pressure Sensor
- Tachometer Signal
- Glow Plug Lamp
- Check Engine Lamp (“On/Off” signal)
- Brake On/Off Switch
- Battery Voltage
- ASD Relay

PCM Outputs:

- A/C On Signal
- Vehicle Theft Alarm “Ok to Run” signal
- Body Control Module CCD Bus (+)
- Body Control Module CCD Bus (-)
- Scan Tool Data Link Receive
- Scan Tool Data Link Transmit
- Low Coolant Lamp
- Generator Control

MASS AIR FLOW SENSOR

The Mass Air Flow Sensor is a gauge that measures air density. In the Mass Air Flow Sensor (MAF) there is a ceramic element that changes its resistance based on temperature. The ceramic element is part of an electronic circuit connected to the MSA, and has a voltage applied to it. The MAF sensor is connected in line with the engine's air intake tube, and when the engine is at idle, there is a relatively low amount of air flowing across the ceramic element. This air has a cooling effect on the ceramic element, and its resistance changes, and a voltage signal is sent to the MSA. As a general rule, when the engine is running at a high RPM, the voltage signal sent by the MAF sensor is high. When the engine is running at a low RPM, the voltage signal sent by the MAF is low. The MSA can calculate the mass (actual weight) of the air flowing through the MAF sensor based on the value of the voltage signal.

VEHICLE THEFT ALARM

The PCM can learn if the vehicle has a Vehicle Theft Alarm (VTA) system. Once it detects the vehicle having VTA, **the controller can ONLY BE USED ON VEHICLES WITH VTA.**

If the PCM is put it on a vehicle without VTA the Glow Plug Lamp will start to blink and the vehicle will not start.

The PCM cannot be flashed to remove the VTA.

BATTERY VOLTAGE—PCM INPUT

The battery voltage input provides power to the PCM. It also informs the PCM what voltage level is being supplied by the generator once the vehicle is running.

The battery input also provides the voltage that is needed to keep the PCM memory alive. The memory stores Diagnostic Trouble Code (DTC) messages. Trouble codes will still be stored even if the battery voltage is lost.

SENSOR RETURN—MSA/PCM INPUT (ANALOG GROUND)

Sensor Return provides a low noise Analog ground reference for all system sensors.

IGNITION CIRCUIT SENSE—MSA/PCM INPUT

The ignition circuit sense input signals the MSA and PCM that the ignition (key) switch has been turned to the ON position. This signal initiates the glow plug control routine to begin the “pre-heat” cycle.

IGNITION CIRCUIT SENSE—PCM INPUT

The ignition circuit sense input signals the PCM that the ignition (key) switch has been turned to the ON position. This signal initiates the glow plug control routine to begin the “pre-heat” cycle.

POWER GROUND

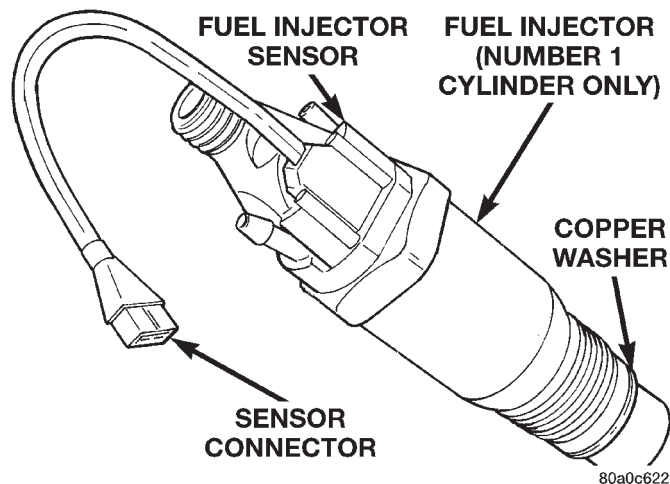
Provides a common ground for power devices (solenoid and relay devices).

NEEDLE MOVEMENT OR INSTRUMENTED FIRST INJECTOR—MSA INPUT

This input from the MSA supplies a constant 30 mA electrical current source for the first injector sensor. It will vary the voltage to this sensor when it senses a mechanical movement within the injector needle (pintle) of the number-1 cylinder fuel injector. When this voltage has been determined by the MSA, it will then control an output to the fuel timing solenoid (the fuel timing solenoid is located on the fuel injection pump). Also refer to Fuel Injection Pump for additional information.

The first injector sensor is a magnetic (inductive) type.

The first injector sensor is used only on the fuel injector for the number-1 cylinder (Fig. 3). It is not used on the injectors for cylinders number 2, 3, or 4.

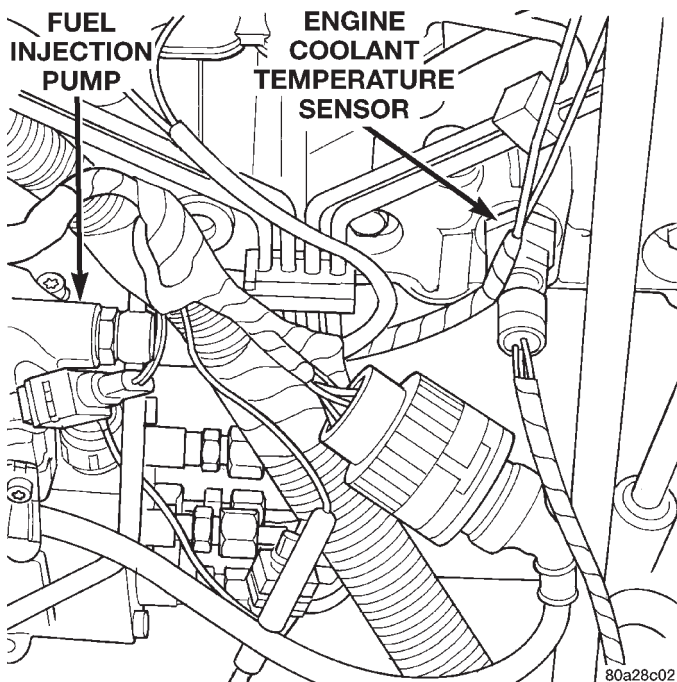
DESCRIPTION AND OPERATION (Continued)**FUEL INJECTOR SENSOR—GROUND****Fig. 3 Fuel Injector Sensor**

Provides a low noise ground for the fuel injector sensor only.

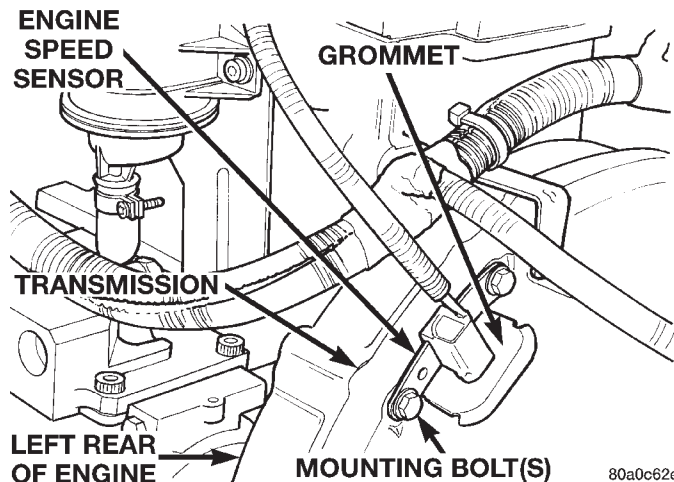
ENGINE COOLANT TEMPERATURE SENSOR—MSA/PCM INPUT

The 0–5 volt input from this sensor tells the MSA and PCM the temperature of the engine coolant. Based on the voltage received at the MSA, it will then determine operation of the fuel timing solenoid, glow plug relay, electrical vacuum modulator (emission component) and generator (charging system).

The sensor is located on the side of the #3 cylinder head near the rear of fuel injection pump (Fig. 4).

**Fig. 4 Engine Coolant Temperature Sensor Location****ENGINE SPEED/CRANK POSITION SENSOR—MSA INPUT**

The engine speed sensor is mounted to the transmission bellhousing at the left/rear side of the engine block (Fig. 5).

**Fig. 5 Engine Speed Sensor Location**

The engine speed sensor produces its own output signal. If this signal is not received, the MSA will not allow the engine to start.

The engine speed sensor input is used in conjunction with the first injector sensor to establish fuel injection pump timing.

The flywheel has four notches at its outer edge (Fig. 6). Each notch is spaced equally every 90°. The notches cause a pulse to be generated when they pass under the speed sensor (Fig. 6). These pulses are the input to the MSA. The input from this sensor determines crankshaft position (in degrees) by monitoring the notches.

The sensor also generates an rpm signal to the MSA. This signal is used as an input for the control of the generator field, vehicle speed control, and instrument panel mounted tachometer.

If the engine speed sensor should fail, the system is unable to compensate for the problem and the car will stop.

AIR CONDITIONING (A/C) CONTROLS—MSA INPUTS

The A/C control system information applies to factory installed air conditioning units.

A/C REQUEST SIGNAL: When either the A/C or Defrost mode has been selected and the A/C low and high-pressure switches are closed, an input signal is sent to the MSA. The MSA uses this input to cycle the A/C compressor through the A/C relay.

If the A/C low or high-pressure switch opens, the MSA will not receive an A/C request signal. The PCM will then remove the ground from the A/C relay. This

DESCRIPTION AND OPERATION (Continued)

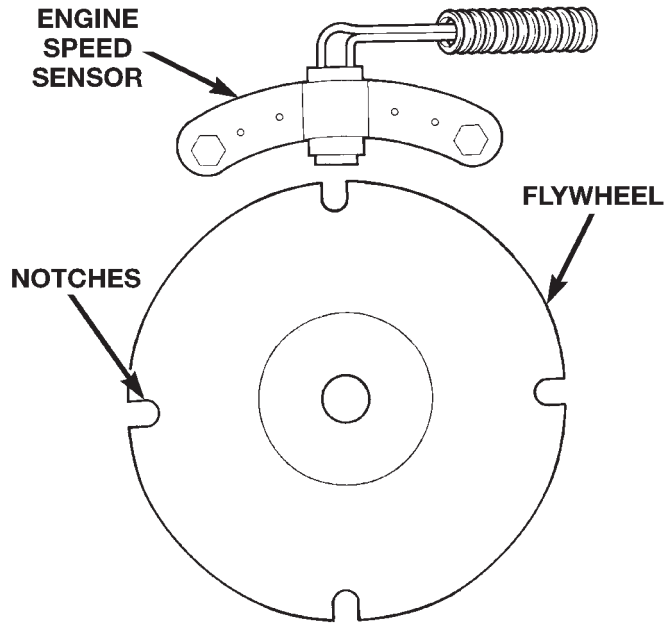


Fig. 6 Speed Sensor Operation

80a0c62f

will deactivate the A/C compressor clutch. Also, if the engine coolant reaches a temperature outside normal of its normal range, or it overheats, the MSA will deactivate the A/C clutch.

BRAKE SWITCH—MSA INPUT

When the brake light switch is activated, the MSA receives an input indicating that the brakes are being applied. After receiving this input, the MSA is used to control the speed control system. There is a Primary and a Secondary brake switch. The Secondary brake switch is closed until the brake pedal is pressed.

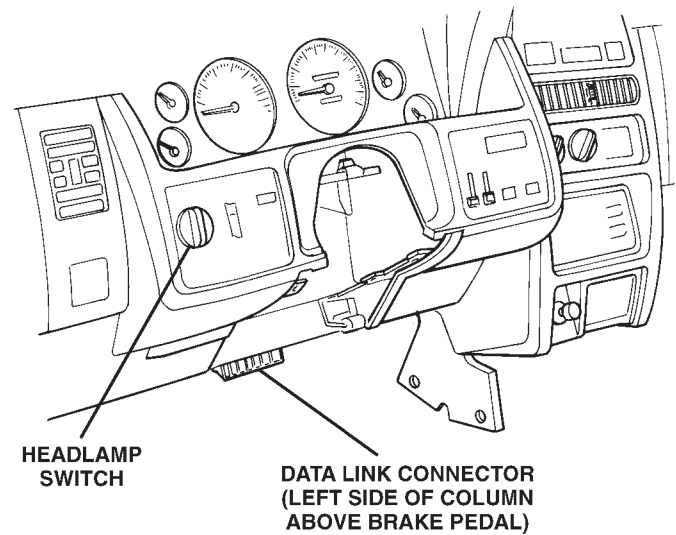
DATA LINK CONNECTOR—PCM AND MSA INPUT AND OUTPUT

The 16-way data link connector (diagnostic scan tool connector) links the Diagnostic Readout Box (DRB) scan tool with the PCM and MSA. The data link connector is located under the instrument panel near the bottom of steering column. (Fig. 7).

VEHICLE SPEED SENSOR—MSA INPUT

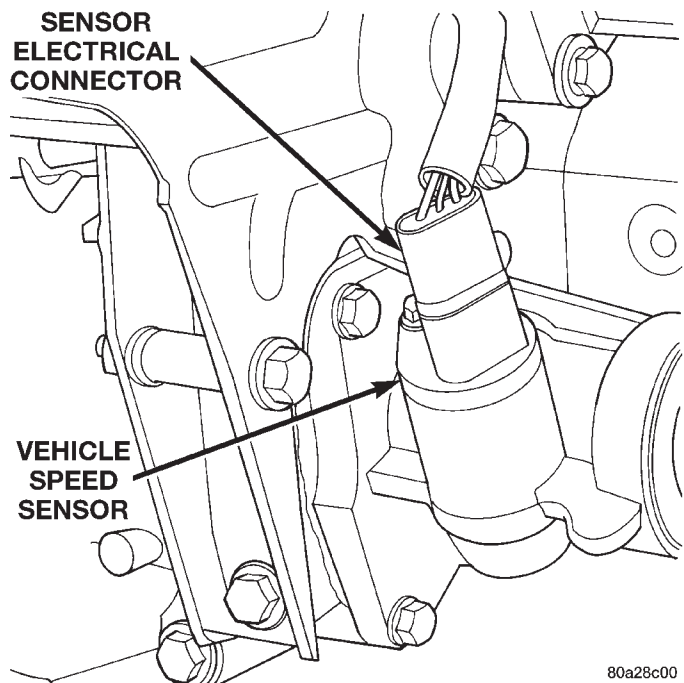
The vehicle speed sensor is located in the extension housing of the transmission (2WD)(Fig. 8) or on the transfer case extension housing (Fig. 9). The sensor input is used by the MSA to determine vehicle speed and distance traveled.

The speed sensor generates 8 pulses per sensor revolution. These signals, in conjunction with a closed throttle signal from the accelerator pedal position sensor, indicate an idle deceleration to the MSA. When the vehicle is stopped at idle, a released pedal



80a07536

Fig. 7 Data Link Connector Location



80a28c00

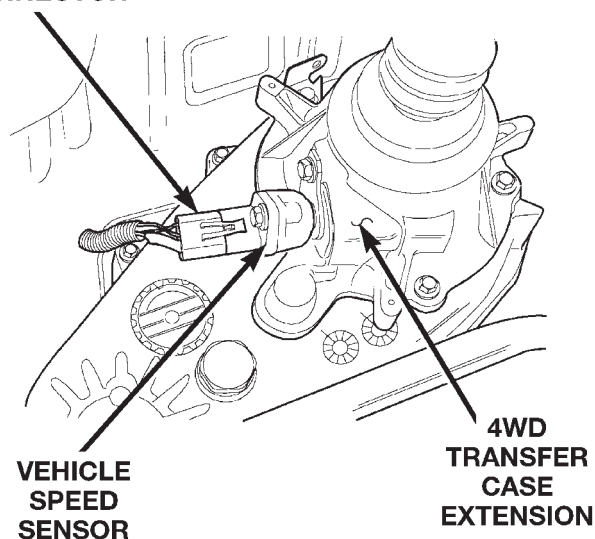
Fig. 8 Vehicle Speed Sensor—Typical

signal is received by the MSA (but a speed sensor signal is not received).

In addition to determining distance and vehicle speed, the output from the sensor is used to control speed control operation.

SPEED CONTROL—MSA INPUT

The speed control system provides five separate inputs to the MSA: On/Off, Set, Resume/Accel, Cancel, and Decel.. The On/Off input informs the MSA that the speed control system has been activated. The Set input informs the MSA that a fixed vehicle speed has been selected. The Resume input indicates

DESCRIPTION AND OPERATION (Continued)**SENSOR ELECTRICAL CONNECTOR**

80a35409

Fig. 9 Vehicle Speed Sensor—4 Wheel Drive

to the MSA that the previous fixed speed is requested.

Speed control operation will start at 50 km/h–142 km/h (35–85 mph). The upper range of operation is not restricted by vehicle speed. Inputs that effect speed control operation are vehicle speed sensor and accelerator pedal position sensor.

Refer to Group 8H for further speed control information.

ASD RELAY—MSA INPUT

A 12 volt signal at this input indicates to the MSA that the ASD relay has been activated. The ASD relay is located in the PDC. The PDC is located next to the battery in the engine compartment. For the location of the relay within the PDC, refer to label on PDC cover.

This input is used only to sense that the ASD relay is energized. If the MSA does not see 12 volts (+) at this input when the ASD relay should be activated, it will set a Diagnostic Trouble Code (DTC).

FIVE VOLT POWER—MSA/PCM OUTPUT

This circuit supplies approximately 5 volts to power the Accelerator Pedal Position Sensor, and Mass Air Flow Sensor.

ENGINE COOLANT GAUGE—PCM OUTPUT

Refer to the Instrument Panel and Gauges group for additional information.

ENGINE OIL PRESSURE GAUGE—PCM OUTPUT

Refer to the Instrument Panel and Gauges group for additional information.

GLOW PLUG LAMP—PCM OUTPUT

The Glow Plug lamp (malfunction indicator lamp) illuminates on the message center each time the ignition (key) switch is turned on (Fig. 10). It will stay on for about two seconds as a bulb test.

**Fig. 10 Glow Plug Lamp Symbol****SPEED CONTROL—PCM OUTPUTS**

These two circuits control the fuel quantity actuator to regulate vehicle speed. Refer to Group 8H for Speed Control information.

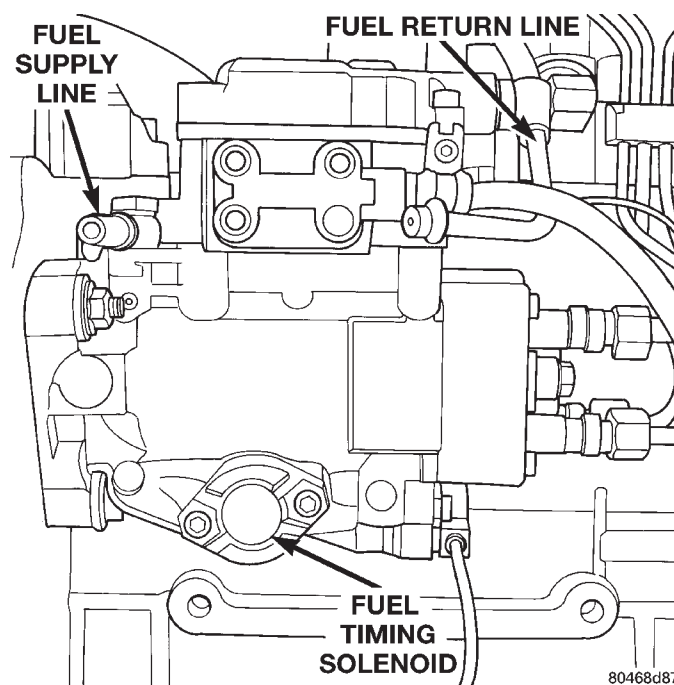
AIR CONDITIONING RELAY—MSA OUTPUT

This circuit controls a ground signal for operation of the A/C clutch relay. Also refer to Air Conditioning (A/C) Controls—MSA Input for additional information.

The A/C relay is located in the Power Distribution Center (PDC). The PDC is located next to the battery in the engine compartment. For the location of the relay within the PDC, refer to label on PDC cover.

FUEL TIMING SOLENOID—MSA OUTPUT

The fuel timing solenoid is located on the bottom of the fuel injection pump (Fig. 11).



80468d87

Fig. 11 Fuel Timing Solenoid

DESCRIPTION AND OPERATION (Continued)

This 12(+) volt, pulse width modulated (duty-cycle) output controls the amount of fuel timing (advance) in the fuel injection pump. The higher the duty-cycle, the lower the advance. The lower the duty-cycle, the more advanced the fuel timing.

The duty-cycle is determined by the MSA from inputs it receives from the fuel injector sensor and engine speed sensor.

TACHOMETER—PCM OUTPUT

The PCM receives engine rpm values from the MSA controller, and then supplies engine rpm values to the Body Controller that then supplies the instrument cluster mounted tachometer (if equipped). Refer to Group 8E for tachometer information.

GLOW PLUG RELAY—MSA OUTPUT

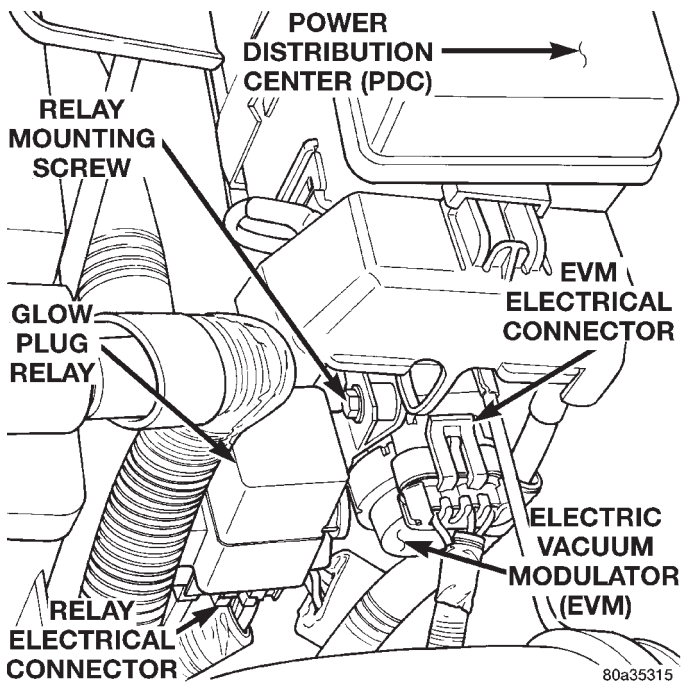


Fig. 12 Glow Plug Relay Location

When the ignition (key) switch is placed in the ON position, a signal is sent to the MSA relating current engine coolant temperature. This signal is sent from the engine coolant temperature sensor.

After receiving this signal, the MSA will determine if, when and for how long a period the glow plug relay should be activated. This is done before, during and after the engine is started. Whenever the glow plug relay is activated, it will control the 12V+ 100 amp circuit for the operation of the four glow plugs.

With a cold engine, the glow plug relay and glow plugs may be activated for a maximum time of 200 seconds. Refer to the following Glow Plug Control chart for a temperature/time comparison of glow plug operation.

In this chart, Pre-Heat and Post-Heat times are mentioned. Pre-heat is the amount of time the glow plug relay circuit is activated when the ignition (key) switch is ON, but the engine has yet to be started. Post-heat is the amount of time the glow plug relay circuit is activated after the engine is operating. The Glow Plug lamp will not be illuminated during the post-heat cycle.

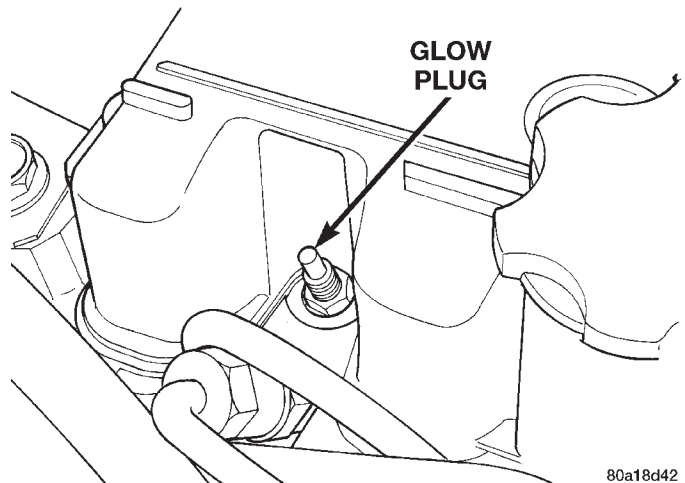
GLOW PLUG CONTROL

ENGINE COOLANT TEMPERATURE KEY ON	WAIT-TO-START LAMP ON (SECONDS)	PRE-HEAT CYCLE (GLOW PLUGS ON) (SECONDS)	POST-HEAT CYCLE (SECONDS)
-30 C	15 SEC.	45 SEC.	200 SEC.
-10 C	8 SEC.	35 SEC.	180 SEC.
+10 C	6 SEC.	25 SEC.	118 SEC.
+30 C	5 SEC.	20 SEC.	70 SEC.
+40 C	4 SEC.	16 SEC.	60 SEC.
+70 C	3 SEC.	16 SEC.	20 SEC.

80a0c517

GLOW PLUGS

Glow plugs are used to help start a cold or cool engine. The plug will heat up and glow to heat the combustion chamber of each cylinder. An individual plug is used for each cylinder. Each plug is threaded into the cylinder head above the fuel injector (Fig. 13).



80a18d42

Fig. 13 Glow Plug

Each plug will momentarily draw approximately 25 amps of electrical current during the initial key-on cycle. This is on a cold or cool engine. After heating,

DESCRIPTION AND OPERATION (Continued)

the current draw will drop to approximately 9–12 amps per plug.

Total momentary current draw for all four plugs is approximately 100 amps on a cold engine dropping to a total of approximately 40 amps after the plugs are heated.

Electrical operation of the glow plugs are controlled by the glow plug relay. Refer to the previous Glow Plug Relay—MSA Output for additional information.

ELECTRIC VACUUM MODULATOR (EVM)—MSA OUTPUT

This circuit controls operation of the Electric Vacuum Modulator (EVM). The EVM (Fig. 12) controls operation of the EGR valve.

Refer to Group 25, Emission Control System for information. See Electric Vacuum Modulator.

DIAGNOSIS AND TESTING

DIESEL DIAGNOSTICS

The MSA controllers perform engine off diagnostic tests, which may be heard for about 60 seconds after turning the key off.

ASD RELAY TEST

To perform a test of the relay and its related circuitry, refer to the DRB scan tool. To test the relay only, refer to Relays—Operation/Testing in this section of the group.

Diagnostic Trouble Codes: Refer to On-Board Diagnostics in Group 25, Emission Control System for a list of Diagnostic Trouble Codes (DTC's) for certain fuel system components.

ENGINE SPEED SENSOR TEST

To perform a test of the engine speed sensor and its related circuitry, refer to the DRB scan tool.

Diagnostic Trouble Codes: Refer to On-Board Diagnostics in Group 25, Emission Control System for a list of Diagnostic Trouble Codes (DTC's) for certain fuel system components.

ENGINE COOLANT TEMPERATURE SENSOR TEST

The sensor is located on the side of cylinder head near the rear of fuel injection pump (Fig. 14).

For a list of Diagnostic Trouble Codes (DTC's) for certain fuel system components, refer to On-Board Diagnostics in Group 25, Emission Control System. To test the sensor only, refer to the following:

- (1) Disconnect wire harness connector from coolant temperature sensor.
- (2) Test the resistance of the sensor with a high input impedance (digital) volt-ohmmeter. The resistance (as measured across the sensor terminals)

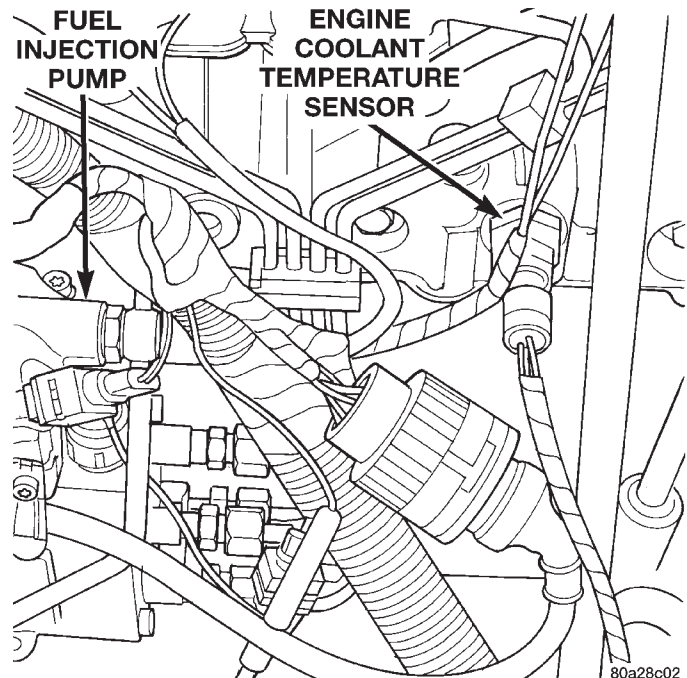


Fig. 14 Engine Coolant Temperature Sensor Location

should be less than 1340 ohms with the engine warm. Refer to the following Sensor Resistance (OHMS) chart. Replace the sensor if it is not within the range of resistance specified in the chart.

SENSOR RESISTANCE (OHMS)

TEMPERATURE		RESISTANCE (OHMS)	
C	F	MIN	MAX
-40	-40	291,490	381,710
-20	-4	85,850	108,390
-10	14	49,250	61,430
0	32	29,330	35,990
10	50	17,990	21,810
20	68	11,370	13,610
25	77	9,120	10,880
30	86	7,370	8,750
40	104	4,900	5,750
50	122	3,330	3,880
60	140	2,310	2,670
70	158	1,630	1,870
80	176	1,170	1,340
90	194	860	970
100	212	640	720
110	230	480	540
120	248	370	410

J928D-4

- (3) Test continuity of the wire harness. Do this between the MSA wire harness connector and the sensor connector terminal. Also test continuity of wire harness to the sensor connector terminal. Refer

DIAGNOSIS AND TESTING (Continued)

to Group 8W for wiring connector and circuitry information. Repair the wire harness if an open circuit is indicated.

(4) After tests are completed, connect electrical connector to sensor.

GLOW PLUG TEST

Hard starting or a rough idle after starting may be caused by one or more defective glow plugs. Before testing the glow plugs, a test of the glow plug relay should be performed. This will ensure that 12V+ is available at the plugs when starting the engine. Refer to the Glow Plug Relay Test for information.

For accurate test results, the glow plugs should be removed from the engine. The plugs must be checked when cold. **Do not check the plugs if the engine has recently been operated. If plugs are checked when warm, incorrect amp gauge readings will result.**

Use Churchill Glow Plug Tester DX.900 or an equivalent (Fig. 15) for the following tests. This tester is equipped with 4 timer lamps.

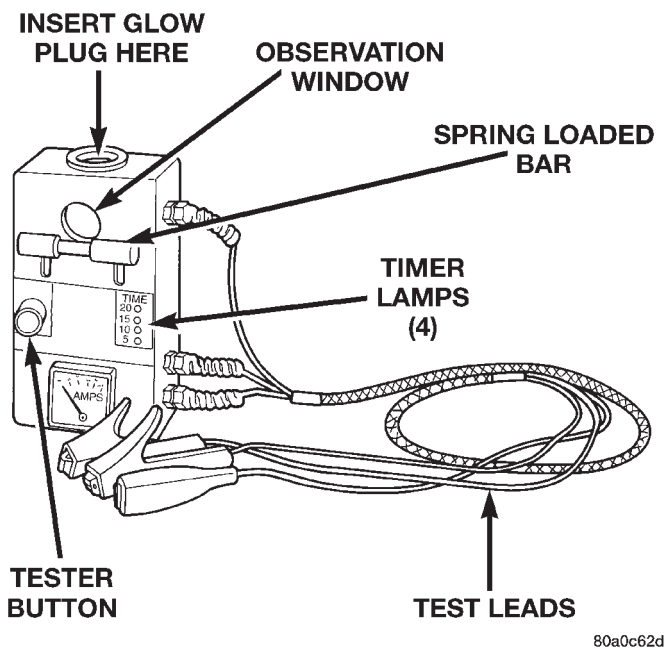


Fig. 15 Typical Glow Plug Tester

- (1) Remove the glow plugs from the engine. Refer to Glow Plug Removal/Installation.
- (2) Attach the red lead of the tester to the 12V+ (positive) side of the battery.
- (3) Attach the black lead of the tester to the 12V- (negative) side of the battery.
- (4) Fit the glow plug into the top of the tester and secure it with the spring loaded bar (Fig. 15).
- (5) Attach the third lead wire of the tester to the electrical terminal at the end of the glow plug.

(6) When performing the test, the tester button (Fig. 15) should be held continuously without release for 20 seconds as indicated by the 4 timer lamps. Each illuminated lamp represents a 5 second time lapse.

(a) Press and hold the tester button (Fig. 15) and note the amp gauge reading. The gauge reading should indicate a momentary, initial current draw (surge) of approximately 25 amps. After the initial surge, the amp gauge reading should begin to fall off. The glow plug tip should start to glow an orange color after 5 seconds. If the tip did not glow after 5 seconds, replace the glow plug. Before discarding the glow plug, check the position of the circuit breaker on the bottom of the plug tester. It may have to be reset. Reset if necessary.

(b) Continue to hold the tester button while observing the amp gauge and the 4 timer lamps. When all 4 lamps are illuminated, indicating a 20 second time lapse, the amp gauge reading should indicate a 9–12 amp current draw. If not, replace the glow plug. Refer to Glow Plug Removal/Installation.

(7) Check each glow plug in this manner using one 20 second cycle. If the glow plug is to be retested, it must first be allowed to cool to room temperature.

WARNING: THE GLOW PLUG WILL BECOME EXTREMELY HOT (GLOWING) DURING THESE TESTS. BURNS COULD RESULT IF IMPROPERLY HANDLED. ALLOW THE GLOW PLUG TO COOL BEFORE REMOVING FROM TESTER.

(8) Remove the glow plug from the tester.

GLOW PLUG RELAY TEST

The glow plug relay is located in the engine compartment on the left-inner fender (Fig. 16).

When the ignition (key) switch is placed in the ON position, a signal is sent to the MSA relating current engine coolant temperature. This signal is sent from the engine coolant temperature sensor.

After receiving this signal, the MSA will determine if, when and for how long a period the glow plug relay should be activated. This is done before, during and after the engine is started. Whenever the glow plug relay is activated, it will control the 12V+ 100 amp circuit for the operation of the four glow plugs.

The Glow Plug lamp is tied to this circuit. Lamp operation is also controlled by the MSA.

With a cold engine, the glow plug relay and glow plugs may be activated for a maximum time of 200 seconds. Refer to the Glow Plug Control chart for a temperature/time comparison of glow plug relay operation.

In this chart, Pre-Heat and Post-Heat times are mentioned. Pre-heat is the amount of time the glow

DIAGNOSIS AND TESTING (Continued)

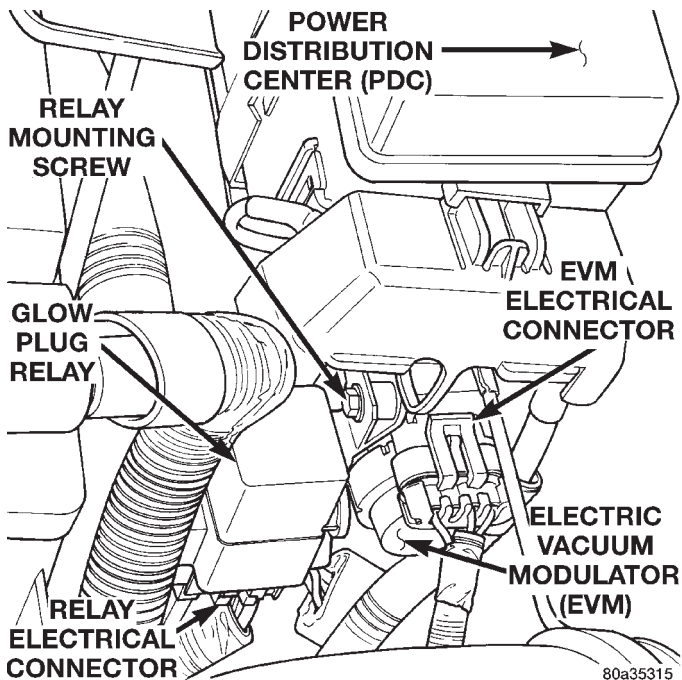


Fig. 16 Glow Plug Relay Location

plug relay circuit is activated when the ignition (key) switch is ON, but the engine has yet to be started. Post-heat is the amount of time the glow plug relay circuit is activated after the engine is operating. The Glow Plug lamp will not be illuminated during the post-heat cycle.

TESTING:

Disconnect and isolate the electrical connectors (Fig. 17) at all four glow plugs. With the engine cool or cold, and the key in the ON position, check for 10–12 volts + at each electrical connector. 10–12 volts + should be at each connector whenever the MSA is operating in the pre-heat or post-heat cycles (refer to the following Glow Plug Control chart). **Be very careful not to allow any of the four disconnected glow plug electrical connectors to contact a metal surface. When the key is turned to the ON position, approximately 100 amps at 12 volts is supplied to these connectors.** If 10–12 volts + is not available at each connector, check continuity of wiring harness directly to the relay. If continuity is good directly to the relay, the fault is either with the relay or the relay input from the MSA. To test the relay only, refer to Relays—Operation/Testing in this section of the group. If the relay test is good, refer to the DRB scan tool.

Diagnostic Trouble Codes: Refer to On-Board Diagnostics in Group 25, Emission Control System for a list of Diagnostic Trouble Codes (DTC's) for certain fuel system components.

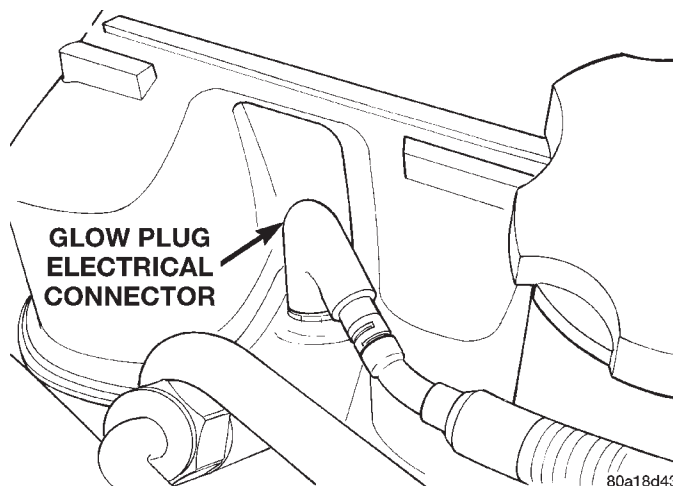


Fig. 17 Wiring Connection at Glow Plug

GLOW PLUG CONTROL

ENGINE COOLANT TEMPERATURE KEY ON	WAIT-TO-START LAMP ON (SECONDS)	PRE-HEAT CYCLE (GLOW PLUGS ON) (SECONDS)	POST-HEAT CYCLE (SECONDS)
-30 C	15 SEC.	45 SEC.	200 SEC.
-10 C	8 SEC.	35 SEC.	180 SEC.
+10 C	6 SEC.	25 SEC.	118 SEC.
+30 C	5 SEC.	20 SEC.	70 SEC.
+40 C	4 SEC.	16 SEC.	60 SEC.
+70 C	3 SEC.	16 SEC.	20 SEC.

80a0c517

RELAYS—OPERATION/TESTING

The following description of operation and tests apply only to the ASD and other relays. The terminals on the bottom of each relay are numbered (Fig. 18).

OPERATION

- Terminal number 30 is connected to battery voltage. For both the ASD and other relays, terminal 30 is connected to battery voltage at all times.
- The MSA grounds the coil side of the relay through terminal number 85.
- Terminal number 86 supplies voltage to the coil side of the relay.
- When the PCM de-energizes the ASD and other relays, terminal number 87A connects to terminal 30. This is the Off position. In the off position, voltage is not supplied to the rest of the circuit. Terminal 87A is the center terminal on the relay.

DIAGNOSIS AND TESTING (Continued)

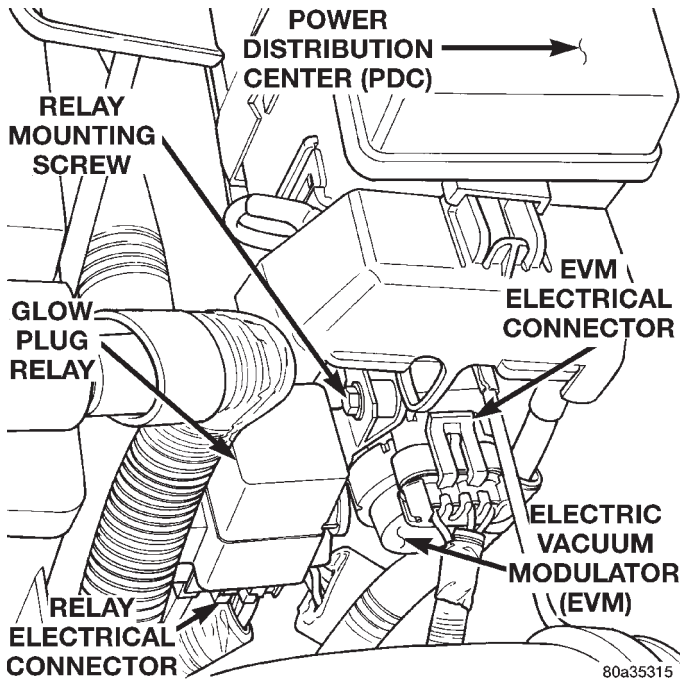


Fig. 18 ASD and Other Relay Terminals

- When the MSA energizes the ASD and other relays, terminal 87 connects to terminal 30. This is the On position. Terminal 87 supplies voltage to the rest of the circuit.

TESTING

The following procedure applies to the ASD and other relays.

- (1) Remove relay from connector before testing.
- (2) With the relay removed from the vehicle, use an ohmmeter to check the resistance between terminals 85 and 86. The resistance should be between 75 ±5 ohms.
- (3) Connect the ohmmeter between terminals 30 and 87A. The ohmmeter should show continuity between terminals 30 and 87A.
- (4) Connect the ohmmeter between terminals 87 and 30. The ohmmeter should not show continuity at this time.
- (5) Connect one end of a jumper wire (16 gauge or smaller) to relay terminal 85. Connect the other end of the jumper wire to the ground side of a 12 volt power source.
- (6) Connect one end of another jumper wire (16 gauge or smaller) to the power side of the 12 volt power source. **Do not attach the other end of the jumper wire to the relay at this time.**

WARNING: DO NOT ALLOW OHMMETER TO CONTACT TERMINALS 85 OR 86 DURING THIS TEST.

- (7) Attach the other end of the jumper wire to relay terminal 86. This activates the relay. The ohm-

meter should now show continuity between relay terminals 87 and 30. The ohmmeter should not show continuity between relay terminals 87A and 30.

- (8) Disconnect jumper wires.
- (9) Replace the relay if it did not pass the continuity and resistance tests. If the relay passed the tests, it operates properly. Check the remainder of the ASD and other relay circuits. Refer to group 8W, Wiring Diagrams.

MASS AIR FLOW SENSOR

The Mass Air Flow (MAF) sensor can only be tested by checking for a fault code stored in the MSA. If the mass air flow sensor stops functioning, you will experience a loss of power, as if you had no turbocharger operation. The MSA may indicate no turbo operation if there is no signal from the MAF sensor. If the sensor sets a fault and no loss of power then check to see if there is a clogged air filter.

VEHICLE SPEED SENSOR TEST

To perform a test of the sensor and its related circuitry, refer to DRB scan tool.

Diagnostic Trouble Codes: Refer to On-Board Diagnostics in Group 25, Emission Control System for a list of Diagnostic Trouble Codes (DTC's) for certain fuel system components.

DIAGNOSTIC TROUBLE CODES

For a list of Diagnostic Trouble Codes (DTC's), refer to Group 25, Emission Control System for information. See On-Board Diagnostics.

REMOVAL AND INSTALLATION

ASD RELAY

The ASD relay is located in the PDC. For the location of the relay within the PDC, refer to label on PDC cover.

A/C CLUTCH RELAY

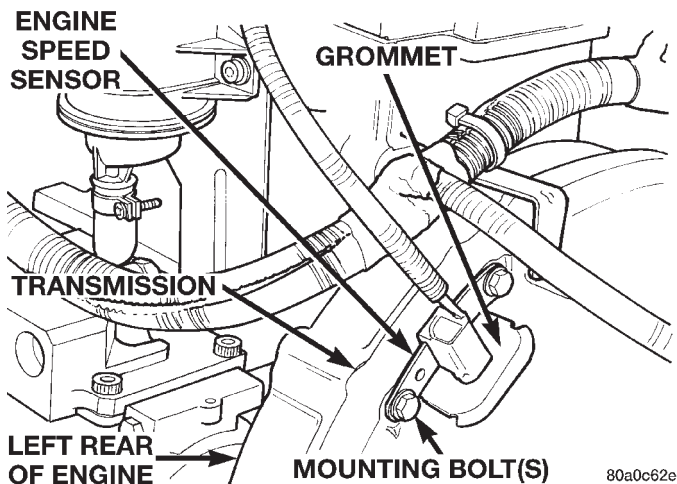
The A/C clutch relay is located in the PDC. For the location of the relay within the PDC, refer to label on PDC cover.

ENGINE SPEED SENSOR

The engine speed sensor is mounted to the transmission bellhousing at the rear of the engine block (Fig. 19).

REMOVAL

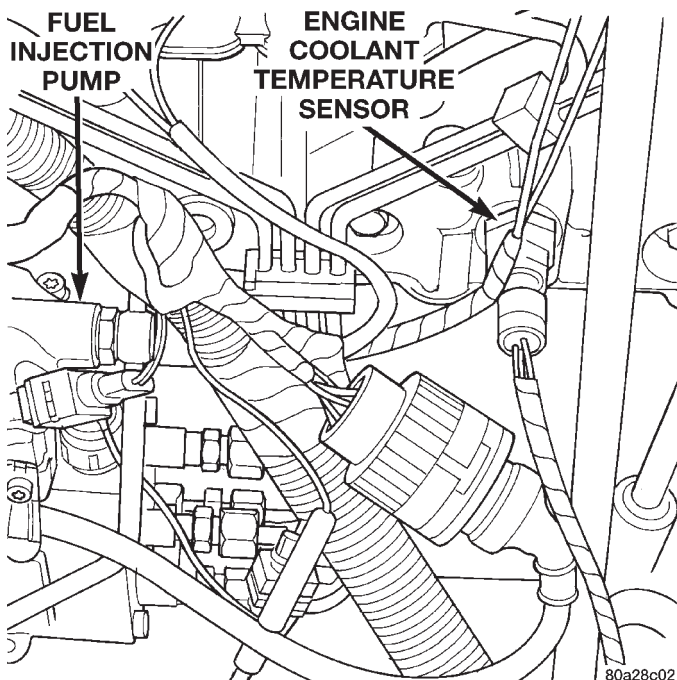
- (1) Disconnect the harness (on the sensor) from the main electrical harness.
- (2) Remove the sensor mounting bolts.
- (3) Remove the sensor.

REMOVAL AND INSTALLATION (Continued)**Fig. 19 Engine Speed Sensor****INSTALLATION**

- (1) Install the sensor flush against the opening in the transmission housing.
- (2) Install and tighten the sensor mounting bolt to 19 N·m (14 ft. lbs.) torque.
- (3) Connect the electrical connector to the sensor.

ENGINE COOLANT TEMPERATURE SENSOR

The sensor is located on the side of cylinder head near the rear of fuel injection pump (Fig. 20).

**Fig. 20 Engine Coolant Temperature Sensor Location****REMOVAL**

WARNING: HOT, PRESSURIZED COOLANT CAN CAUSE INJURY BY SCALDING. COOLING SYSTEM

MUST BE PARTIALLY DRAINED BEFORE REMOVING THE COOLANT TEMPERATURE SENSOR. REFER TO GROUP 7, COOLING.

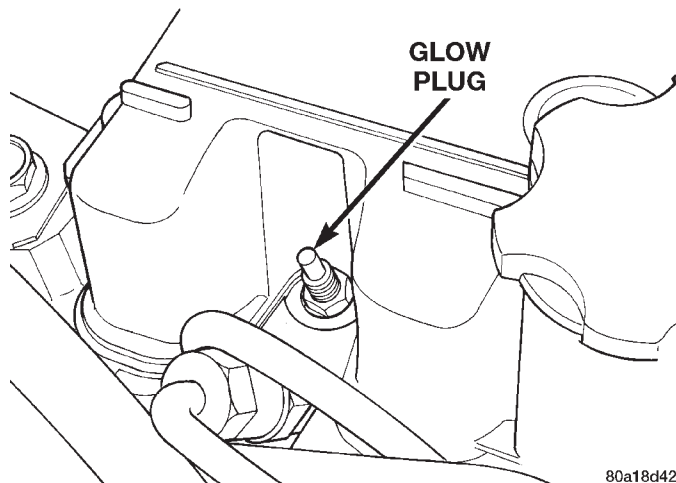
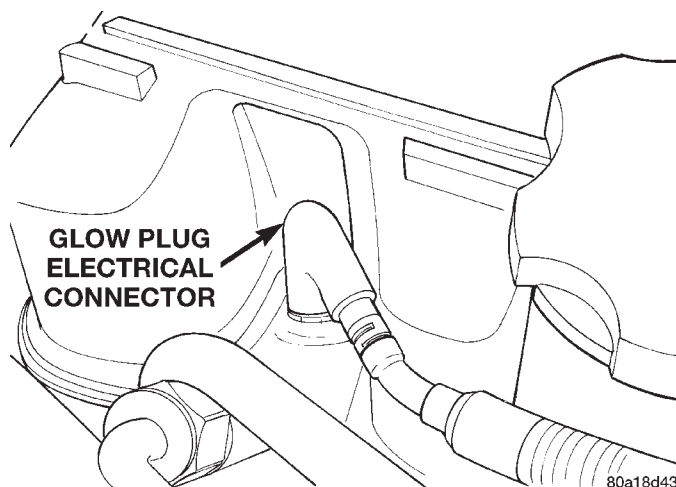
- (1) Partially drain cooling system. Refer to Group 7, Cooling.
- (2) Disconnect electrical connector from sensor.
- (3) Remove sensor from cylinder head.

INSTALLATION

- (1) Install a new copper gasket to sensor.
- (2) Install sensor to cylinder head.
- (3) Tighten sensor to 18 N·m (13 ft. lbs.) torque.
- (4) Connect electrical connector to sensor.
- (5) Replace any lost engine coolant. Refer to Group 7, Cooling System.

GLOW PLUGS

The glow plugs are located above each fuel injector (Fig. 21). Four individual plugs are used.

**Fig. 21 Glow Plug****Fig. 22 Glow Plug Electrical Connector**

REMOVAL AND INSTALLATION (Continued)

REMOVAL

- (1) Disconnect the negative battery cable at the battery.
- (2) Clean the area around the glow plug with compressed air before removal.
- (3) Disconnect electrical connector (Fig. 22) at glow plug.
- (4) Remove the glow plug (Fig. 21) from cylinder head.

INSTALLATION

- (1) Apply high-temperature anti-seize compound to glow plug threads before installation.
- (2) Install the glow plug into the cylinder head. Tighten to 23 N·m (203 in. lbs.) torque.
- (3) Connect battery cable to battery.

GLOW PLUG RELAY

The glow plug relay is located in the engine compartment on the left-inner fender (Fig. 23).

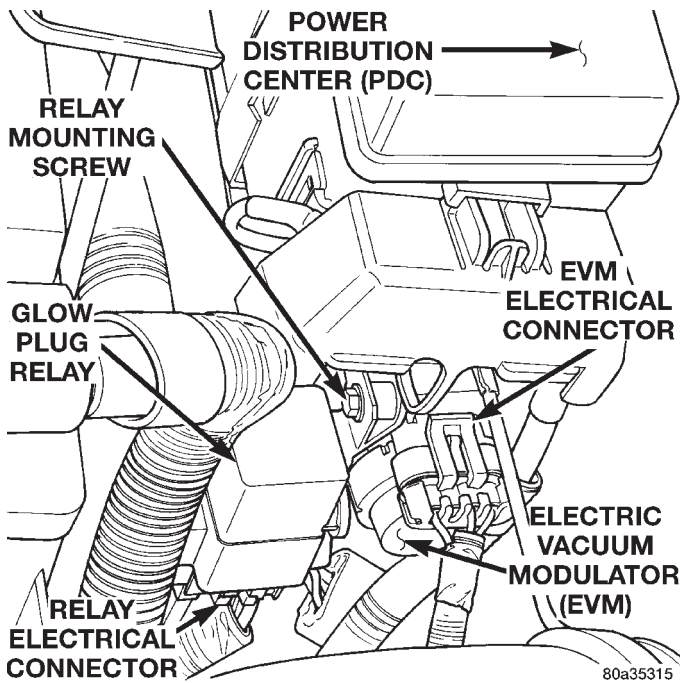


Fig. 23 Glow Plug Relay Location

REMOVAL

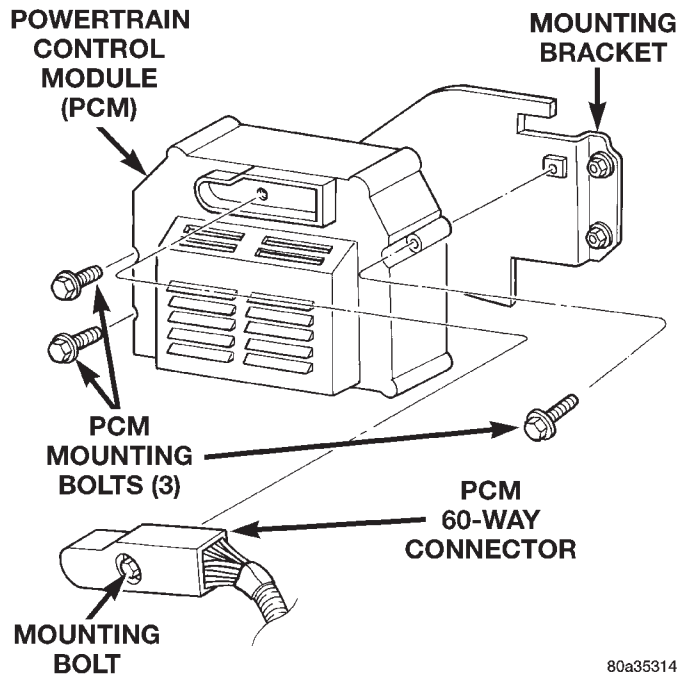
- (1) Disconnect the negative battery cable at the battery.
- (2) Remove relay mounting bolt.
- (3) Disconnect electrical connector at relay and remove relay.

INSTALLATION

- (1) Check condition of electrical connector for damage or corrosion. Repair as necessary.
- (2) Install electrical connector to relay.
- (3) Install relay to inner fender.
- (4) Connect battery cable to battery.

POWERTRAIN CONTROL MODULE (PCM)

The PCM is mounted to a bracket mounted to the inner side of the right fender well behind the air cleaner assembly.(Fig. 24).



80a35314

Fig. 24 PCM Location

REMOVAL

- (1) Disconnect the negative battery cable at the battery.
- (2) Loosen the 60-Way connector (Fig. 24). The electrical connector has a sliding bar which moves inward to lock or outward to unlock.
- (3) Remove the electrical connector by pulling straight out.
- (4) Remove PCM.

INSTALLATION

- (1) After the PCM electrical connector has been separated from the PCM, inspect the pins for corrosion, being spread apart, bent or misaligned. Also inspect the pin heights in the connector. If the pin heights are different, this would indicate a pin has separated from the connector. Repair as necessary.
- (2) Engage 60-way connector into PCM. Move slide bar to lock connector.
- (3) Connect negative cable to battery.

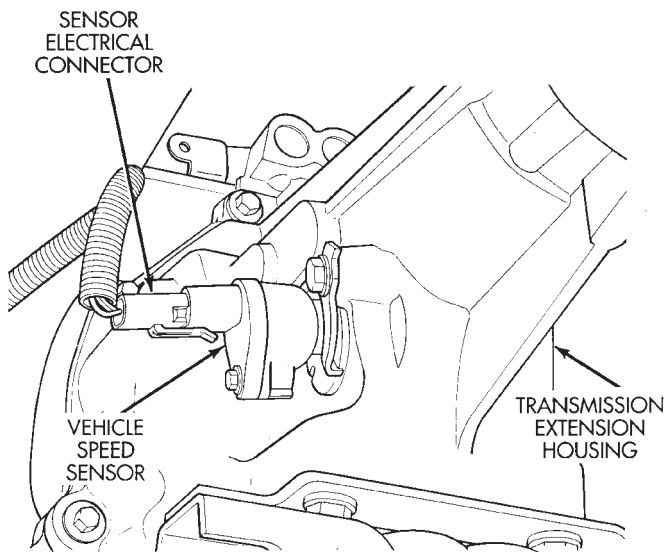
VEHICLE SPEED SENSOR

The vehicle speed sensor (Fig. 25) is located on the extension housing of the transmission for 2 wheel drive vehicle, or on the transfer case housing for 4 wheel drive vehicles (Fig. 26).

REMOVAL

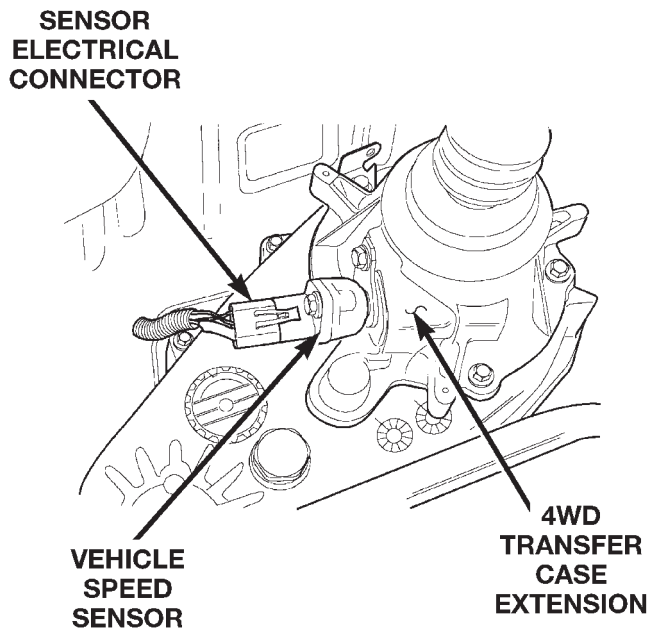
- (1) Raise and support vehicle.

REMOVAL AND INSTALLATION (Continued)



J9414-60

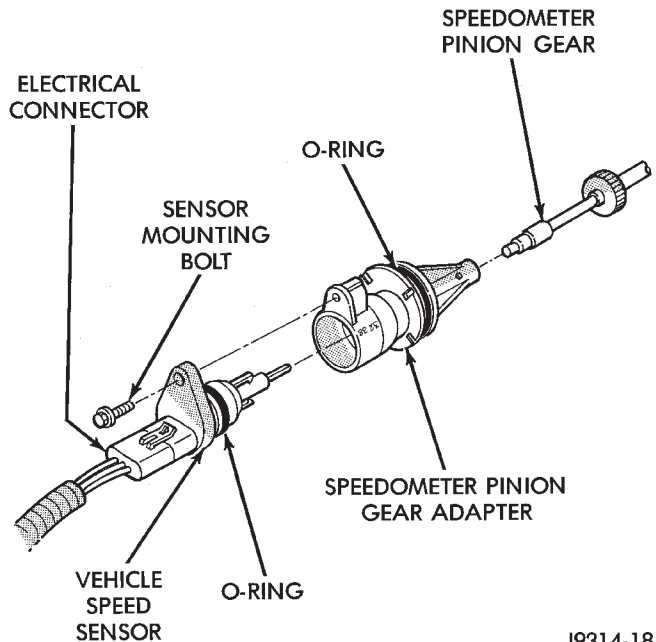
Fig. 25 Vehicle Speed Sensor Location—2 Wheel Drive



80a35409

Fig. 26 Vehicle Speed Sensor Location—4WD

- (2) Clean the area around the sensor before removal.
- (3) Disconnect the electrical connector from the sensor (Fig. 27).
- (4) Remove the sensor mounting bolt (Fig. 27).
- (5) Pull the sensor from the speedometer pinion gear adapter for removal.



J9314-188

Fig. 27 Sensor Removal/Installation—Typical

INSTALLATION

- (1) Install new sensor into speedometer gear adapter.
- (2) Tighten sensor mounting bolt. To prevent damage to sensor or speedometer adapter, be sure the sensor is mounted flush to the adapter before tightening.
- (3) Connect electrical connector to sensor.

SPECIFICATIONS**GLOW PLUG CURRENT DRAW**

Initial Current Draw: Approximately 22–25 amps per plug.

After 20 seconds of operation: Approximately 9–12 amps per plug.

SPECIFICATIONS (Continued)

TORQUE CHART—2.5L DIESEL

DESCRIPTION	TORQUE
Accelerator Pedal Bracket Mounting Nuts.....	5 N•m (46 in. lbs.)
Banjo-Type Fittings.....	19 N•m (14 ft. lbs.)
Engine Coolant Temperature Sensor.....	18 N•m (13 ft. lbs.)
Engine Speed Sensor Bolts.....	19 N•m (14 ft. lbs.)
Fuel Hose (Tube) Clamps For Rubber Hose.....	2 N•m (20 in. lbs.)
Fuel Injector.....	70 N•m (52 ft. lbs.)
Fuel Injector Line At Injector.....	30 N•m (22 ft. lbs.)
Fuel Injector Line At Injector Pump.....	30 N•m (22 ft. lbs.)

DESCRIPTION	TORQUE
Fuel Injection Pump Mounting Nuts.....	30 N•m (22 ft. lbs.)
Fuel Injection Pump Drive Gear.....	88 N•m (65 ft. lbs.)
Fuel Line Clamp Bracket Bolts.....	24 N•m (18 ft. lbs.)
Fuel Tank Nuts.....	11 N•m (100 in. lbs.)
Glow Plugs.....	23 N•m (203 in. lbs.)
Powertrain Control Module Mounting Bolts.....	1 N•m (9 in. lbs.)
Throttle Position Sensor Mounting Bolts.....	7 N•m (60 in. lbs.)
Vehicle Speed Sensor Mounting Bolt.....	3 N•m (26 in. lbs.)

STEERING

CONTENTS

	page		page
POWER STEERING GEAR	9	STEERING COLUMN	20
POWER STEERING PUMP	4	STEERING LINKAGE	24
POWER STEERING	1		

POWER STEERING

INDEX

	page		page
GENERAL INFORMATION		DIAGNOSIS AND TESTING	
POWER STEERING SYSTEM	1	POWER STEERING SYSTEM DIAGNOSIS	
		CHARTS	2

GENERAL INFORMATION

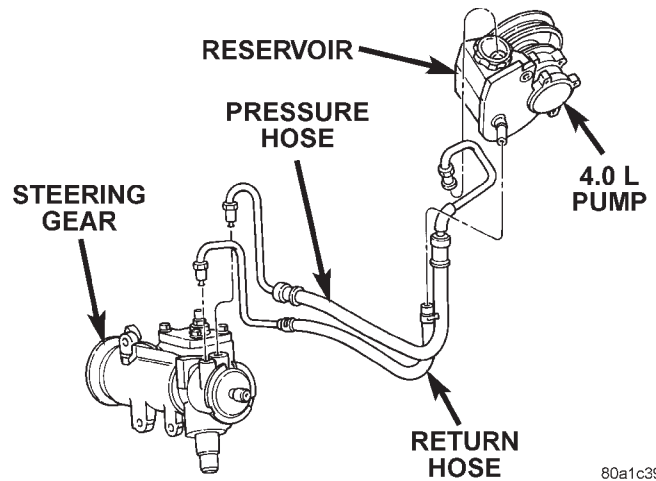
POWER STEERING SYSTEM

The power steering pump (Fig. 1) is a constant flow rate and displacement vane type pump. The pump reservoir is attached to the pump body. The pump is connected to the steering by the pressure and return hoses.

The steering gear (Fig. 1) used is a recirculating ball type gear. The gear acts as a rolling thread between the worm shaft and rack piston. The worm shaft is supported by a thrust bearing at the lower end and a bearing assembly at the upper end. When the worm shaft is turned the rack piston moves. The rack piston teeth mesh with the pitman shaft. Turning the worm shaft turns the pitman shaft, which moves the steering linkage.

The power steering system consists of:

- Hydraulic pump
- Recirculating ball steering gear
- Steering column
- Steering linkage



80a1c394

Fig. 1 Power Steering Gear & Pump

DIAGNOSIS AND TESTING**POWER STEERING SYSTEM DIAGNOSIS CHARTS****STEERING NOISE**

There is some noise in all power steering systems. One of the most common is a hissing sound evident at a standstill parking. Or when the steering wheel is at the end of it's travel. Hiss is a high frequency noise similar to that of a water tap being closed slowly. The noise is present in all valves that have a high velocity fluid passing through an orifice. There is no relationship between this noise and steering performance.

CONDITION	POSSIBLE CAUSES	CORRECTION
OBJECTIONAL HISS OR 'WHISTLE	1. Steering intermediate shaft to dash panel seal. 2. Noisy valve in power steering gear.	1. Check and repair seal at dash panel. 2. Replace steering gear.
RATTLE OR CLUNK	1. Gear mounting bolts loose. 2. Loose or damaged suspension components. 3. Loose or damaged steering linkage. 4. Internal gear noise. 5. Pressure hose in contact with other components.	1. Tighten bolts to specification. 2. Inspect and repair suspension. 3. Inspect and repair steering linkage. 4. Replace gear. 5. Reposition hose.
CHIRP OR SQUEAL	1. Loose belt.	1. Adjust or replace.
WHINE OR GROWL	1. Low fluid level. 2. Pressure hose in contact with other components. 3. Internal pump noise.	1. Fill to proper level. 2. Reposition hose. 3. Replace pump.
SUCKING AIR SOUND	1. Loose return line clamp. 2. O-ring missing or damaged on hose fitting. 3. Low fluid level. 4. Air leak between pump and reservoir.	1. Replace clamp. 2. Replace o-ring. 3. Fill to proper level. 4. Repair as necessary.
SCRUBBING OR KNOCKING	1. Wrong tire size. 2. Wrong gear.	1. Verify tire size. 2. Verify gear.

BINDING AND STICKING

CONDITION	POSSIBLE CAUSE	CORRECTION
DIFFICULT TO TURN WHEEL STICKS OR BINDS	1. Low fluid level. 2. Tire pressure. 3. Steering component. 4. Loose belt. 5. Low pump pressure. 6. Column shaft coupler binding. 7. Steering gear worn or out of adjustment.	1. Fill to proper level. 2. Adjust tire pressure. 3. Inspect and lube. 4. Adjust or replace. 5. Pressure test and replace if necessary. 6. Replace coupler. 7. Repair or replace gear.

DIAGNOSIS AND TESTING (Continued)

INSUFFICIENT ASST. OR POOR RETURN TO CENTER

CONDITION	POSSIBLE CAUSE	CORRECTION
HARD TURNING OR MOMENTARY INCREASE IN TURNING EFFORT	<ol style="list-style-type: none"> 1. Tire pressure. 2. Low fluid level. 3. Loose belt. 4. Lack of lubrication. 5. Low pump pressure. 6. Internal gear leak. 	<ol style="list-style-type: none"> 1. Adjust tire pressure. 2. Fill to proper level. 3. Adjust or replace. 4. Inspect and lubricate steering and suspension compnents. 5. Pressure test and repair as necessary. 6. Pressure and flow test, and repair as necessary.
STEERING WHEEL DOES NOT WANT TO RETURN TO CENTER POSITION	<ol style="list-style-type: none"> 1. Tire pressure. 2. Wheel alignment. 3. Lack of lubrication. 4. High friction in steering gear. 	<ol style="list-style-type: none"> 1. Adjust tire pressure. 2. Align front end. 3. Inspect and lubricate steering and suspension compnents. 4. Test and adjust as necessary.

LOOSE STEERING AND VEHICLE LEAD

CONDITION	POSSIBLE CAUSE	CORRECTION
EXCESSIVE PLAY IN STEERING WHEEL	<ol style="list-style-type: none"> 1. Worn or loose suspension or steering components. 2. Worn or loose wheel bearings. 3. Steering gear mounting. 4. Gear out of adjustment. 5. Worn or loose steering coupler. 	<ol style="list-style-type: none"> 1. Repair as necessary. 2. Repair as necessary. 3. Tighten gear mounting bolts to specification. 4. Adjust gear to specification. 5. Repair as necessary.
VEHICLE PULLS OR LEADS TO ONE SIDE	<ol style="list-style-type: none"> 1. Tire Pressure. 2. Radial tire lead. 3. Brakes dragging. 4. Wheel alignment. 5. Weak or broken spring. 6. Loose or worn steering or suspension components. 	<ol style="list-style-type: none"> 1. Adjust tire pressure. 2. Rotate tires. 3. Repair as necessary. 4. Align vehicle. 5. Replace spring. 6. Repair as necessary.

POWER STEERING PUMP

INDEX

	page		page
DESCRIPTION AND OPERATION		POWER STEERING PUMP- 4.0L	6
POWER STEERING PUMP	4	DISASSEMBLY AND ASSEMBLY	
DIAGNOSIS AND TESTING		PUMP PULLEY	7
PUMP FLOW RATE AND PRESSURE	4	PUMP RESERVOIR	7
PUMP LEAKAGE DIAGNOSIS	5	SPECIFICATIONS	
SERVICE PROCEDURES		TORQUE CHART	8
POWER STEERING PUMP - INITIAL		SPECIAL TOOLS	
OPERATION	5	POWER STEERING PUMP	8
REMOVAL AND INSTALLATION			
POWER STEERING PUMP - 5.2L/5.9L	6		

DESCRIPTION AND OPERATION

POWER STEERING PUMP

Hydraulic pressure for the power steering system is provided by a belt driven power steering pump (Fig. 1). The pump shaft has a pressed-on drive pulley that is belt driven by the crankshaft pulley. The power steering pump is a constant flow rate and displacement, vane-type pump. The pump internal parts operate submerged in fluid. The flow control orifice is part of the high pressure line fitting. The pressure relief valve inside the flow control valve limits the pump pressure. The reservoir is attached to the pump body with spring clips. The power steering pump is connected to the steering gear by the pressure and return hoses.

NOTE: Power steering pumps have different pressure rates and are not interchangeable with other pumps.

DIAGNOSIS AND TESTING

PUMP FLOW RATE AND PRESSURE

The following procedure is used to test the operation of the power steering system on the vehicle. This test will provide the gallons per minute (GPM) or flow rate of the power steering pump along with the maximum relief pressure. Perform test any time a power steering system problem is present. This test will determine if the power steering pump or power steering gear is not functioning properly. The following pressure and flow test is performed using Power Steering Analyzer Tool kit 6815 (Fig. 2) and Adapter Kit 6893.

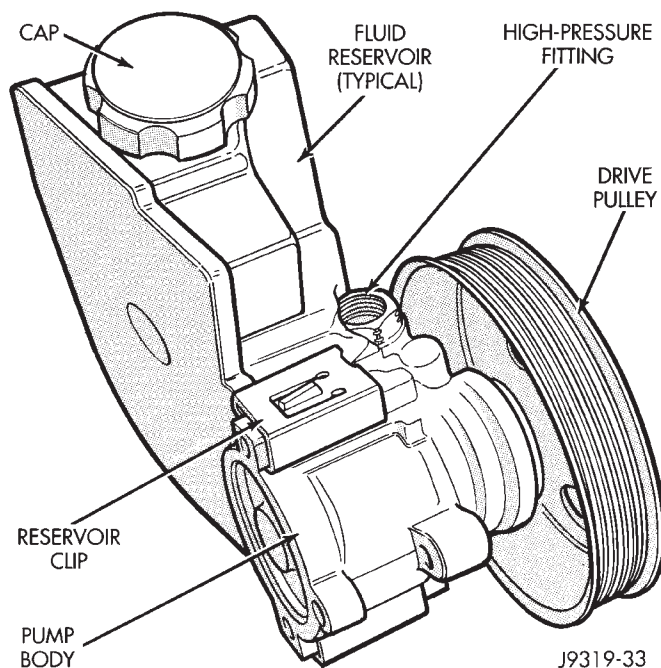
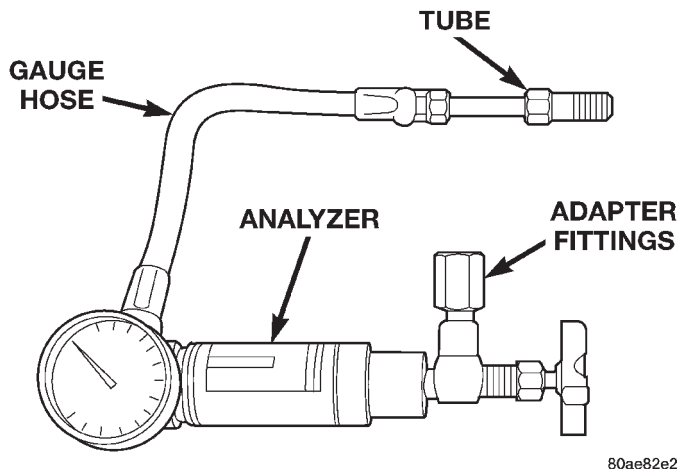


Fig. 1 Pump With Integral Reservoir

FLOW AND PRESSURE TEST

- (1) Check the power steering belt to ensure it is in good condition and adjusted properly.
- (2) Connect pressure gauge hose from the Power Steering Analyzer to Tube 6865.
- (3) Connect Adapter 6826 to Power Steering Analyzer test valve end.
- (4) Disconnect the high pressure hose from the power steering pump.
- (5) Connect Tube 6865 to the pump hose fitting.
- (6) Connect the power steering hose from the steering gear to Adapter 6826.
- (7) Open the test valve completely.

DIAGNOSIS AND TESTING (Continued)



80ae82e2

Fig. 2 Power Steering Analyzer

(8) Start engine and let idle long enough to circulate power steering fluid through flow/pressure test gauge.

(9) Shut off the engine and check the fluid level, add fluid as necessary. Start engine again and let idle.

(10) Gauge should read below 862 kPa (125 psi), if above, inspect the hoses for restrictions and repair as necessary. The initial pressure reading should be in the range of 345-552 kPa (50-80 psi).

(11) Increase the engine speed to 1500 RPM and read the flow meter. The reading should be 2.4 - 2.8 GPM, if the reading is below this specification the pump should be replaced.

CAUTION: This next step involves testing maximum pump pressure output and flow control valve operation. Do not leave valve closed for more than three seconds as the pump could be damaged.

(12) Close valve fully three times for three seconds and record highest pressure indicated each time. **All three readings must be above pump relief pressure specifications and within 345 kPa (50 psi) of each other.**

- Pressures above specifications but not within 345 kPa (50 psi) of each other, replace pump.

- Pressures within 345 kPa (50 psi) of each other but below specifications, replace pump.

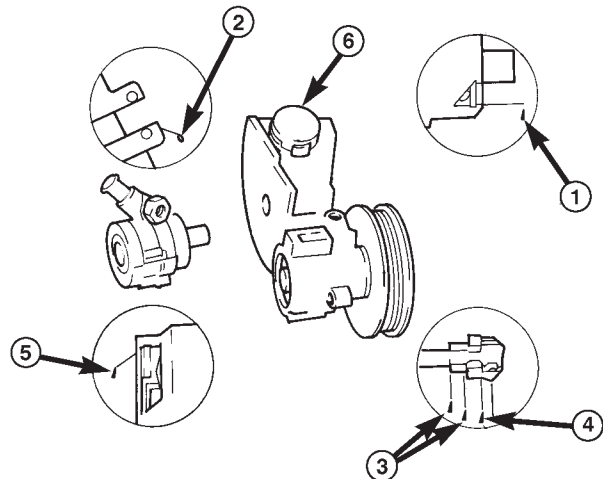
(13) Open the test valve and turn the steering wheel to the extreme left and right positions against the stops. Record the highest pressure reading at each position. Compare readings to the pump specifications chart. If pressures readings are not within 50 psi. of each other, the gear is leaking internally and must be repaired.

CAUTION: Do not force the pump to operate against the stops for more than 2 to 4 seconds at a time because, pump damage will result.

PUMP SPECIFICATIONS

ENGINE	RELIEF PRESSURE ± 50	FLOW RATE (GPM)
4.0L	9653 kPa (1400 psi)	1500 RPM 2.4 - 2.8 GPM
5.2L	9653 kPa (1400 psi)	
5.9L	9653 kPa (1400 psi)	

PUMP LEAKAGE DIAGNOSIS



1. BUSHING (BEARING) WORN, SEAL WORN. REPLACE PUMP.
2. REPLACE RESERVOIR O-RING SEAL.
3. TORQUE HOSE FITTING NUT TO SPECIFICATIONS. IF LEAKAGE PERSISTS, REPLACE O-RING SEAL.
4. TORQUE FITTING TO SPECIFICATIONS. IF LEAKAGE PERSISTS, REPLACE O-RING SEAL.
5. REPLACE PUMP.
6. CHECK OIL LEVEL: IF LEAKAGE PERSISTS WITH THE LEVEL CORRECT AND CAP TIGHT, REPLACE THE CAP.

80a1c3c3

SERVICE PROCEDURES

POWER STEERING PUMP – INITIAL OPERATION

WARNING: THE FLUID LEVEL SHOULD BE CHECKED WITH ENGINE OFF TO PREVENT INJURY FROM MOVING COMPONENTS.

CAUTION: Use MOPAR Power Steering Fluid or equivalent. Do not use automatic transmission fluid and do not overfill.

Wipe filler cap clean, then check the fluid level. The dipstick should indicate **COLD** when the fluid is at normal temperature.

(1) Fill the pump fluid reservoir to the proper level and let the fluid settle for at least two minutes.

SERVICE PROCEDURES (Continued)

- (2) Start the engine and let run for a few seconds then turn engine off.
- (3) Add fluid if necessary. Repeat the above procedure until the fluid level remains constant after running the engine.
- (4) Raise the front wheels off the ground.
- (5) Slowly turn the steering wheel right and left, lightly contacting the wheel stops at least 20 times.
- (6) Check the fluid level add if necessary.
- (7) Lower the vehicle, start the engine and turn the steering wheel slowly from lock to lock.
- (8) Stop the engine and check the fluid level and refill as required.
- (9) If the fluid is extremely foamy or milky looking, allow the vehicle to stand a few minutes and repeat the procedure.

CAUTION: Do not run a vehicle with foamy fluid for an extended period. This may cause pump damage.

REMOVAL AND INSTALLATION**POWER STEERING PUMP- 4.0L****REMOVAL**

- (1) Remove serpentine drive belt, refer to Group 7 Cooling.
- (2) Vehicles equipped with Speed Proportional Steering, disconnect actuator harness.
- (3) Remove pressure and return hoses from pump and drain pump.

- (4) Remove 3 pump mounting bolts through pulley access holes.
- (5) Loosen the 3 pump bracket bolts (Fig. 3).
- (6) Tilt pump downward and remove from engine.
- (7) Remove pulley from pump.

INSTALLATION

- (1) Install pulley on pump.
- (2) Install pump on engine.
- (3) Tighten pump bracket bolts to 47 N·m (35 ft. lbs.).
- (4) Install 3 pump mounting bolts and tighten to 27 N·m (20 ft. lbs.).
- (5) Install the pressure and return hoses to pump.
- (6) Vehicles equipped with Speed Pro Steering, connect actuator harness.
- (7) Install drive belt, refer to Group 7 Cooling.
- (8) Add power steering fluid. Refer to Power Steering Pump Initial Operation in this section.

POWER STEERING PUMP – 5.2L/5.9L**REMOVAL**

- (1) Remove the serpentine drive belt. Refer to Group 7 Cooling.
- (2) Remove the pressure and return hoses from pump and drain pump.
- (3) Vehicles equipped with Speed Proportional Steering, disconnect actuator harness.
- (4) Remove pump mounting bolts and remove the pump (Fig. 4).
- (5) Remove pulley from pump.

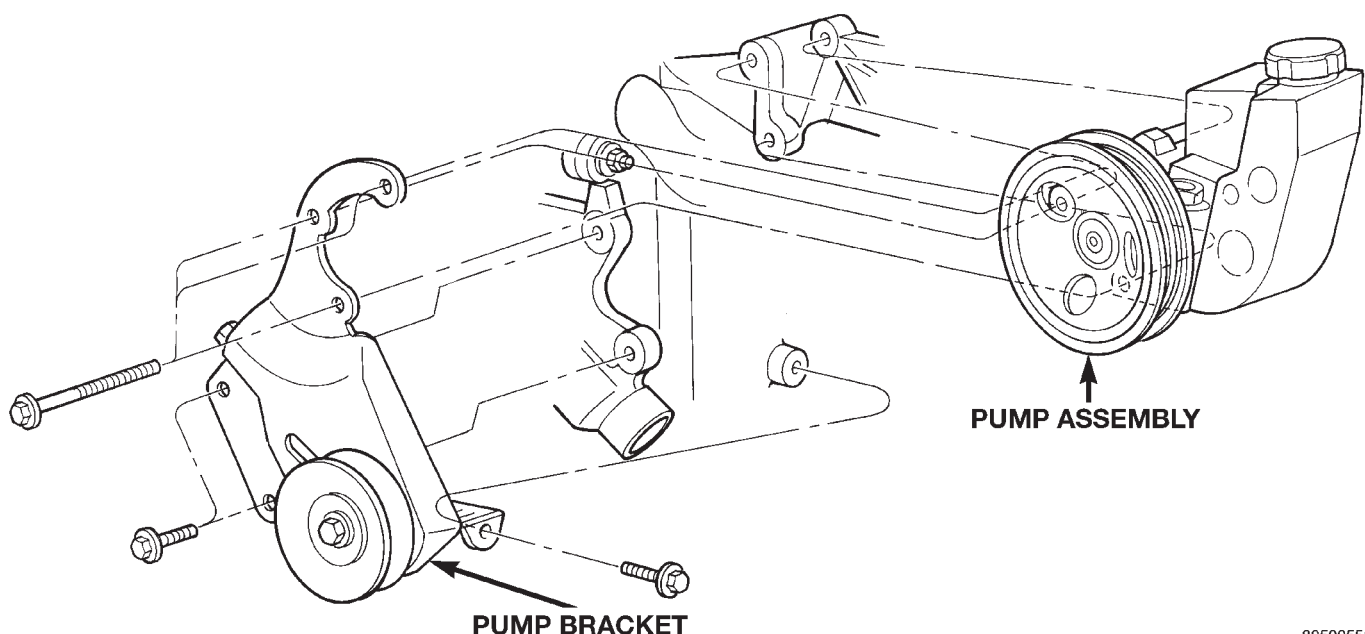


Fig. 3 Pump Mounting – 4.0L

REMOVAL AND INSTALLATION (Continued)

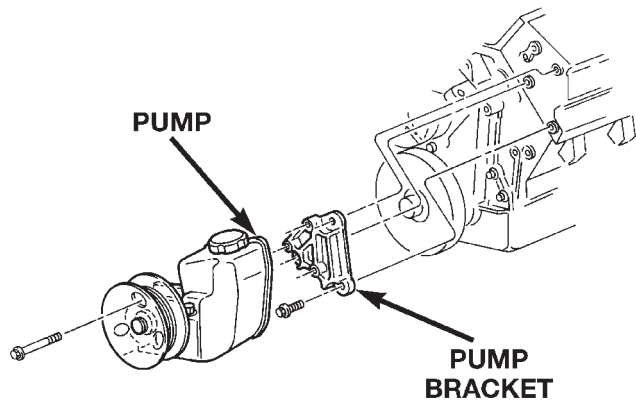


Fig. 4 Pump Mounting – 5.2L/59L

80500556

INSTALLATION

- (1) Install pulley on pump.
- (2) Mount pump on bracket and install bolts. Tighten bolts to 27 N·m (20 ft. lbs.).
- (3) Install the pressure and return hoses to pump.
- (4) Vehicles equipped with Speed Pro Steering, connect actuator harness.
- (5) Install drive belt, refer to Group 7 Cooling.
- (6) Add power steering fluid. Refer to Power Steering Pump Initial Operation in this section.

DISASSEMBLY AND ASSEMBLY

PUMP PULLEY

DISASSEMBLY

- (1) Remove pump assembly.
- (2) Remove pulley from pump with Puller C-4333 (Fig. 5).

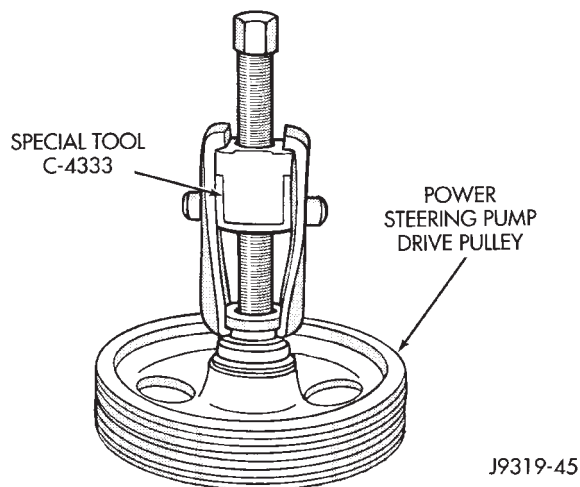


Fig. 5 Pulley Removal

J9319-45

ASSEMBLY

- (1) Replace pulley if bent, cracked, or loose.

- (2) Install pulley on pump with Installer C-4063-B (Fig. 6) flush with the end of the shaft. Ensure the tool and pulley remain aligned with the pump shaft.

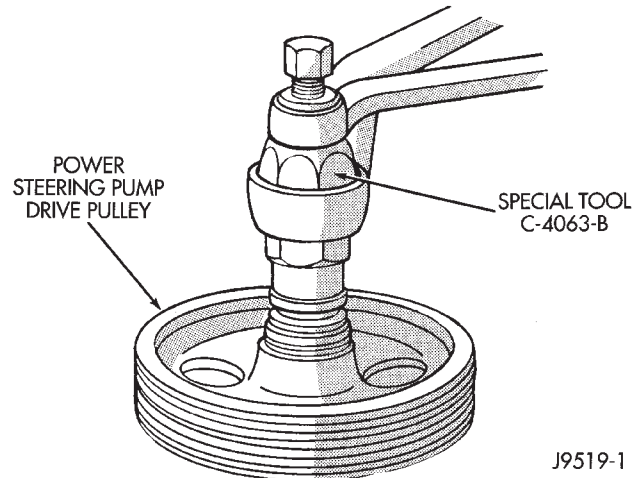


Fig. 6 Pulley Installation

J9519-1

- (3) Install pump assembly.
- (4) With Serpentine Belt, run engine until warm (5 min.) and note any belt chirp. If chirp exists, move pulley outward approximately 0.5 mm (0.020 in.). If noise increases, press on 1.0 mm (0.040 in.). **Be careful that pulley does not contact mounting bolts.**

PUMP RESERVOIR

DISASSEMBLY

- (1) Remove power steering pump.
- (2) Clean exterior of pump.
- (3) Clamp the pump body in a soft jaw vice.
- (4) Pry up tab and slide the retaining clips off (Fig. 7).

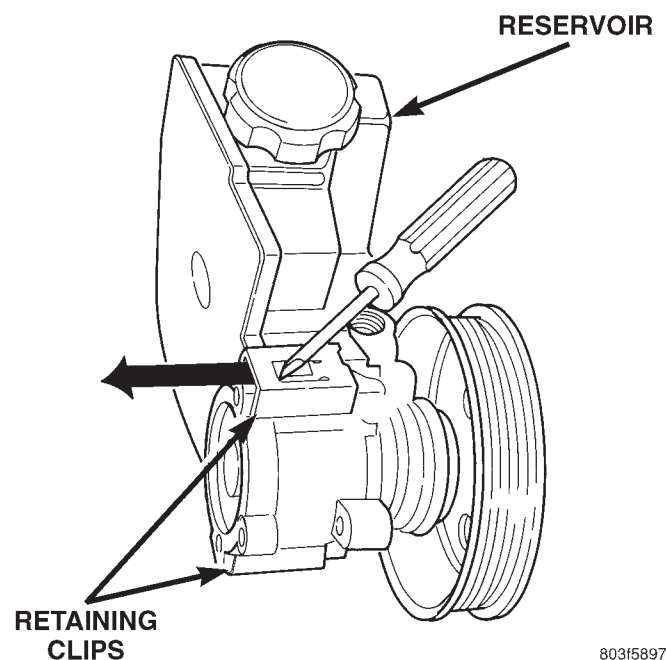


Fig. 7 Pump Reservoir Clips

80315897

DISASSEMBLY AND ASSEMBLY (Continued)

(5) Remove fluid reservoir from pump body.
Remove and discard O-ring seal.

ASSEMBLY

- (1) Lubricate new O-ring Seal with Mopar Power Steering Fluid or equivalent.
- (2) Install O-ring seal in housing.
- (3) Install reservoir onto housing.
- (4) Slide and tap in reservoir retainer clips until tab locks to housing.
- (5) Install power steering pump.
- (6) Add power steering fluid, refer to Pump Initial Operation.

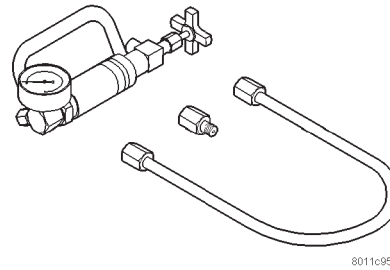
SPECIFICATIONS

TORQUE CHART

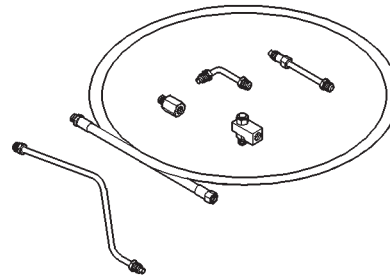
DESCRIPTION	TORQUE
Power Steering Pump	
Bracket Bolts	41 N·m (30 ft. lbs.)
Pump Bolts	27 N·m (20 ft. lbs.)
Flow Control Valve	75 N·m (55 ft. lbs.)
Pressure Line	28 N·m (21 ft. lbs.)

SPECIAL TOOLS

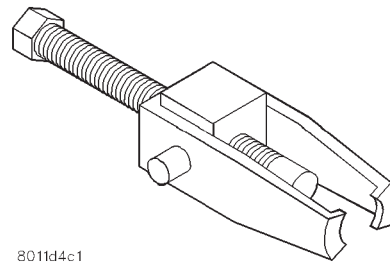
POWER STEERING PUMP



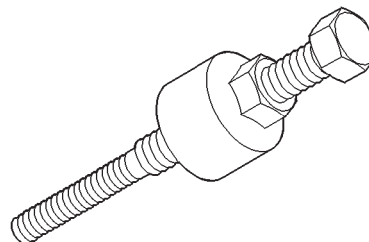
Analyzer Set, Power Steering Flow/Pressure 6815



Adapters, Power Steering Flow/Pressure Tester 6893



Puller C-4333



Installer, Power Steering Pulley C-4063-B

POWER STEERING GEAR

INDEX

	page		page
DESCRIPTION AND OPERATION		RACK PISTON AND WORM SHAFT	15
POWER STEERING GEAR	9	SPOOL VALVE	13
DIAGNOSIS AND TESTING		ADJUSTMENTS	
POWER STEERING GEAR LEAKAGE		STEERING GEAR	17
DIAGNOSIS	10	SPECIFICATIONS	
REMOVAL AND INSTALLATION		POWER STEERING GEAR	19
STEERING GEAR	10	TORQUE CHART	19
DISASSEMBLY AND ASSEMBLY		SPECIAL TOOLS	
HOUSING END PLUG	11	POWER STEERING GEAR	19
PITMAN SHAFT/SEALS/BEARING	11		

DESCRIPTION AND OPERATION

POWER STEERING GEAR

The power steering gear is a recirculating ball type gear (Fig. 1). The gear acts as a rolling thread between the worm shaft and rack piston. The worm shaft is supported by a thrust bearing at the lower end and a bearing assembly at the upper end. When the worm shaft is turned the rack piston moves. The

rack piston teeth mesh with the pitman shaft. Turning the worm shaft turns the pitman shaft, which turns the steering linkage.

CAUTION: Components attached with a nut and cotter pin must be torqued to specification. Then if the slot in the nut does not line up with the cotter pin hole, tighten nut until it is aligned. Never loosen the nut to align the cotter pin hole.

- 1 — RING, RETAINING
- 2 — PLUG
- 3 — SEAL, O-RING
- 4 — RING, TEFLON
- 5 — COVER, SIDE
- 6 — NUT, ADJUSTER LOCK
- 7 — GASKET
- 8 — SHAFT, PITMAN
- 9 — SHAFT, WORM
- 10 — RACE
- 11 — BEARING, THRUST
- 12 — VALVE, CHECK
- 13 — HOUSING
- 14 — SCREW
- 15 — CLAMP
- 16 — GUIDE, BALL
- 17 — BALLS
- 18 — PISTON, RACK
- 19 — PLUG
- 20 — BEARING, NEEDLE
- 21 — WASHER, BACKUP
- 22 — RING, RETAINING
- 23 — SHAFT, STUB
- 24 — SPOOL, VALVE
- 25 — BODY, VALVE
- 26 — NUT, COUPLING SHIELD RET. AND LOCK
- 27 — THRUST SUPPORT ASSEMBLY
- 28 — SEAL, PITMAN SHAFT
- 29 — SEAL, DUST
- 30 — NUT, ADJUSTER

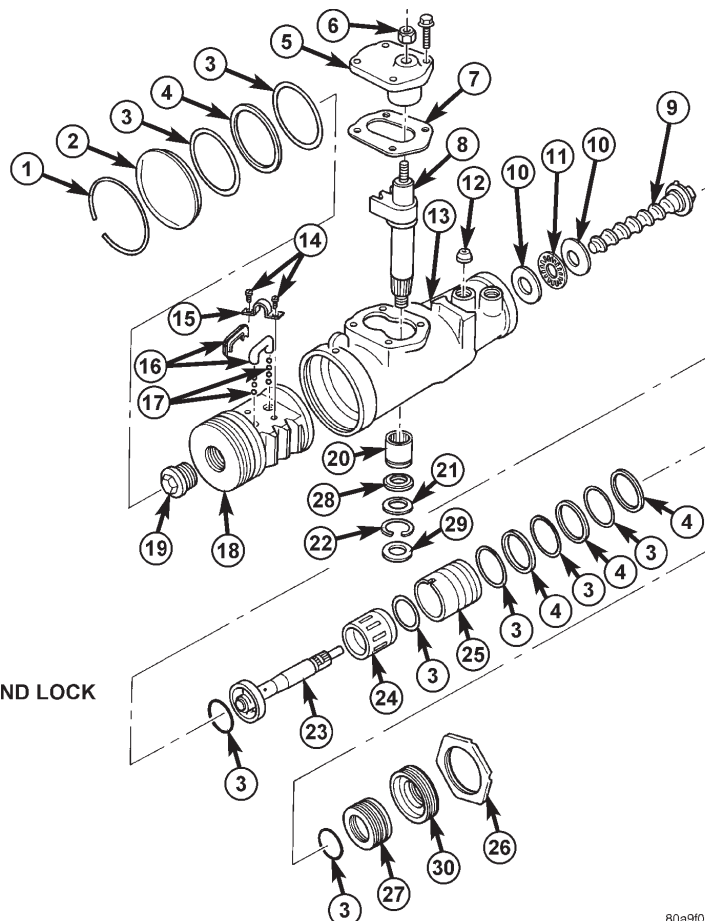
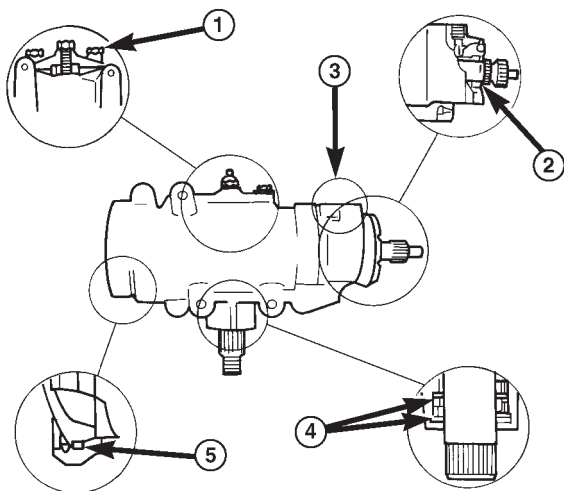


Fig. 1 Recirculating Ball Type Gear

DIAGNOSIS AND TESTING

POWER STEERING GEAR LEAKAGE DIAGNOSIS



- 1. SIDE COVER LEAK - TORQUE SIDE COVER BOLTS TO SPECIFICATION. REPLACE THE SIDE COVER SEAL IF THE LEAKAGE PERSISTS.
- 2. ADJUSTER PLUG SEAL - REPLACE THE ADJUSTER PLUG SEALS.
- 3. PRESSURE LINE FITTING - TORQUE THE HOSE FITTING NUT TO SPECIFICATIONS. IF LEAKAGE PERSISTS, REPLACE THE SEAL.
- 4. PITMAN SHAFT SEALS - REPLACE THE SEALS.
- 5. TOP COVER SEAL - REPLACE THE SEAL.

80a1c3c2

REMOVAL AND INSTALLATION

STEERING GEAR

REMOVAL

- (1) Place the front wheels in the straight ahead position with the steering wheel centered.
- (2) Remove and cap the pressure and return hoses from the steering gear.
- (3) Remove the column coupler shaft from the gear (Fig. 2).
- (4) Remove pitman arm from gear with Puller C-4150A (Fig. 3).
- (5) Remove the steering gear retaining bolts and nuts. Remove the steering gear from the vehicle (Fig. 4).

INSTALLATION

- (1) Position the steering gear on the frame rail and install the bolts. Tighten the bolts to 88 N-m (65 ft. lbs.) torque.
- (2) Install the column coupler shaft.
- (3) Install the pitman arm and tighten nut to 251 N-m (185 ft. lbs.).
- (4) Connect pressure and return hoses to steering gear and tighten to 28 N-m (21 ft. lbs.).

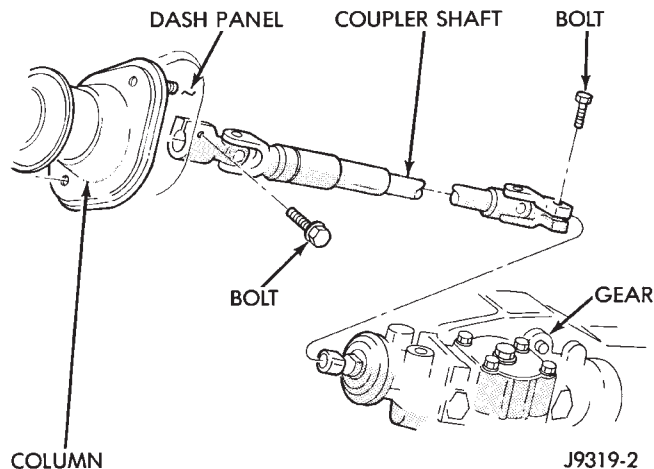


Fig. 2 Coupling Shaft

J9319-2

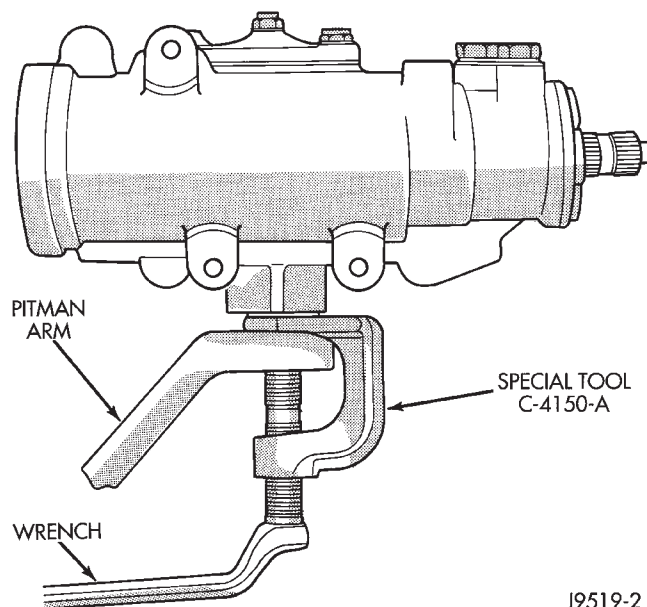


Fig. 3 Pitman Arm Removal

J9519-2

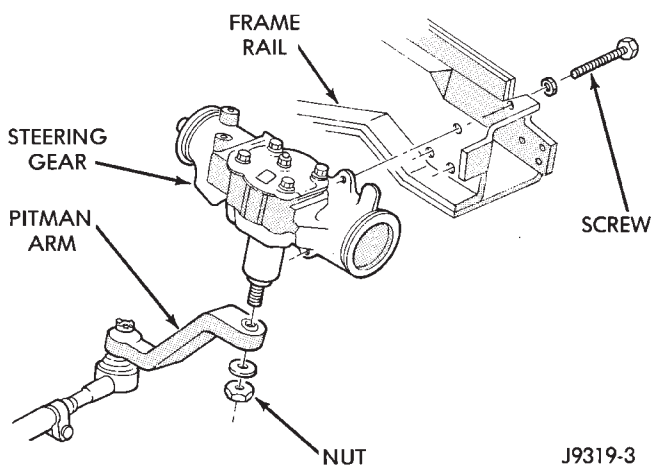


Fig. 4 Steering Gear Mounting

J9319-3

DISASSEMBLY AND ASSEMBLY

HOUSING END PLUG

DISASSEMBLY

(1) Unseat and remove retaining ring from groove with a punch through the hole in the end of the housing (Fig. 5).

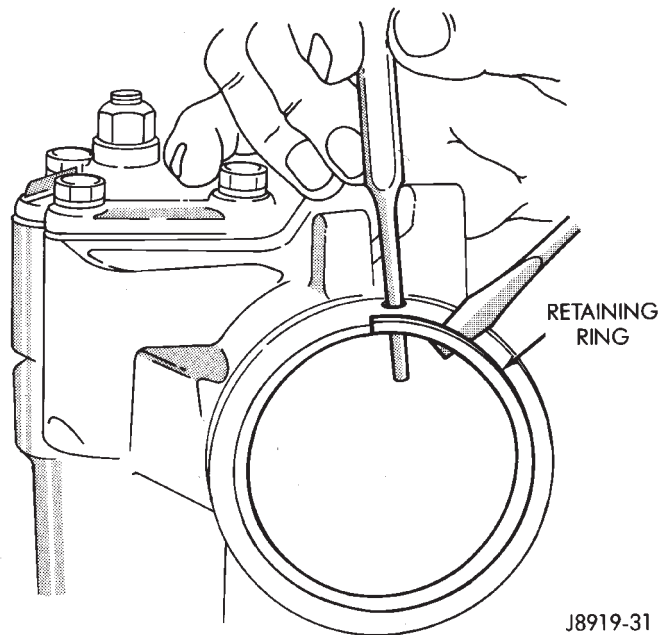


Fig. 5 End Plug Retaining Ring

(2) Slowly rotate stub shaft with 12 point socket COUNTER-CLOCKWISE to force the end plug out from housing.

CAUTION: Do not turn stub shaft any further than necessary. The rack piston balls will drop out of the rack piston circuit if the stub shaft is turned too far.

(3) Remove O-ring from the housing (Fig. 6).

ASSEMBLY

(1) Lubricate O-ring with power steering fluid and install into the housing.

(2) Install end plug by tapping the plug lightly with a plastic mallet into the housing.

(3) Install retaining ring so one end of the ring covers the housing access hole (Fig. 7).

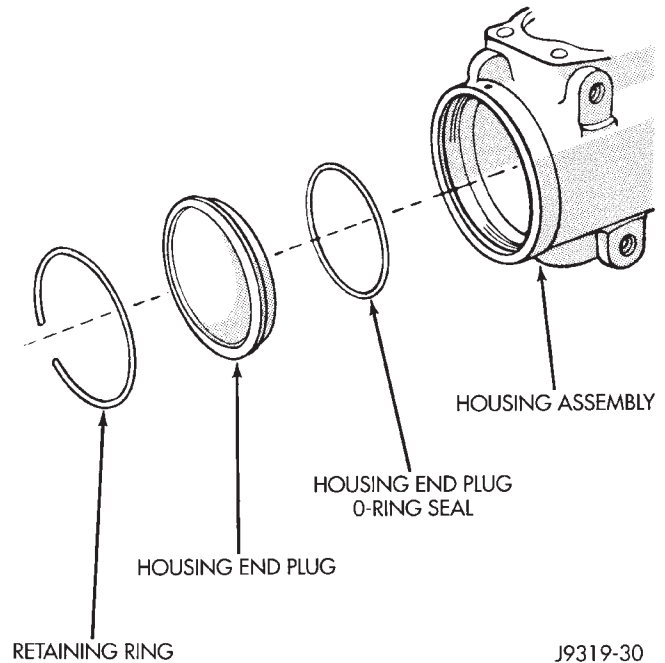


Fig. 6 End Plug Components

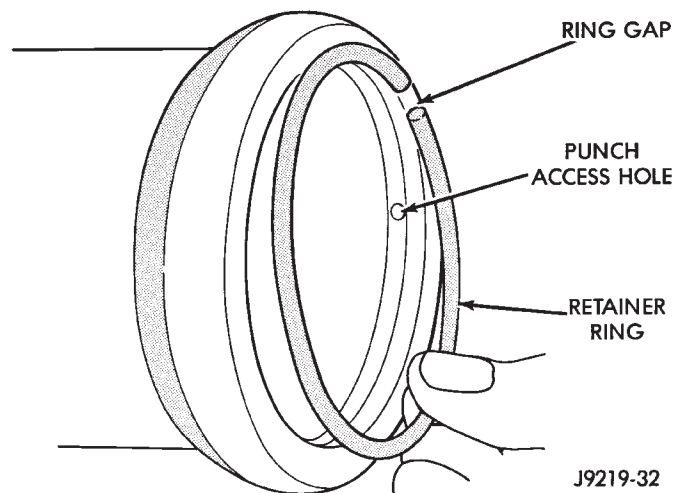


Fig. 7 Installing The Retaining Ring

PITMAN SHAFT/SEALS/BEARING

DISASSEMBLY

(1) Clean exposed end of pitman shaft and housing with a wire brush.

DISASSEMBLY AND ASSEMBLY (Continued)

- (2) Remove preload adjuster nut (Fig. 8).
- (3) Rotate the stub shaft with a 12 point socket from stop to stop and count the number of turns.
- (4) Center the stub shaft by rotating it from the stop 1/2 of the total amount of turns.
- (5) Remove side cover bolts and remove side cover, gasket and pitman shaft as an assembly (Fig. 8).

NOTE: The pitman shaft will not clear the housing if it is not centered.

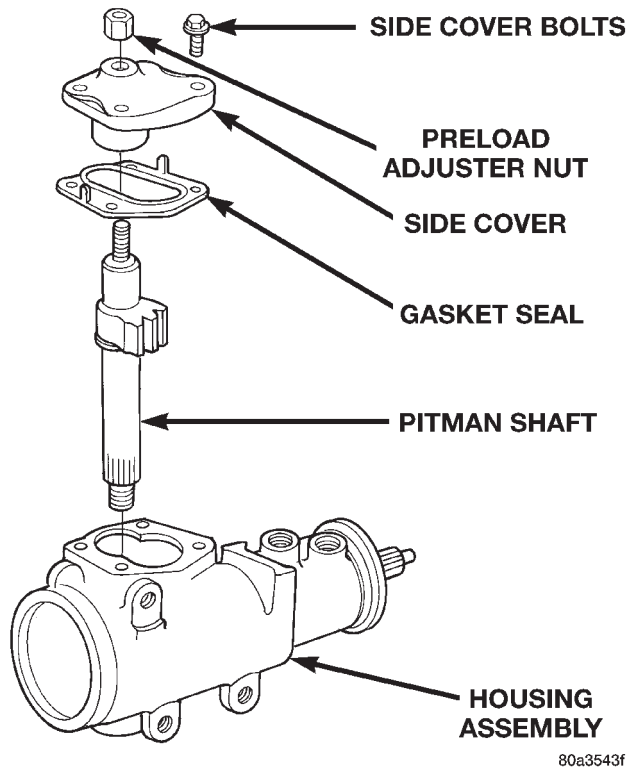


Fig. 8 Side Cover and Pitman Shaft

- (6) Remove pitman shaft from the side cover.
- (7) Remove dust seal from the housing with a seal pick (Fig. 9).

CAUTION: Use care not to score the housing bore when prying out seals and washer.

- (8) Remove retaining ring with snap ring pliers.
- (9) Remove washer from the housing.
- (10) Remove oil seal from the housing with a seal pick.
- (11) Remove pitman shaft bearing from housing with a bearing driver and handle (Fig. 10).

ASSEMBLY

- (1) Install pitman shaft bearing into housing with a bearing driver and handle.
- (2) Coat the oil seals and washer with grease.
- (3) Install the oil seal with a driver and handle.
- (4) Install backup washer.

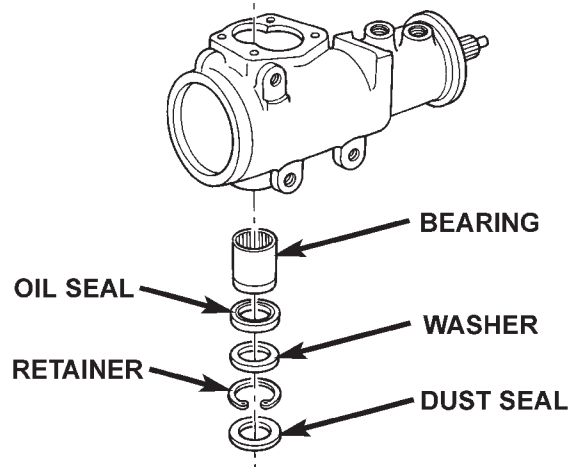


Fig. 9 Pitman Shaft Seals & Bearing

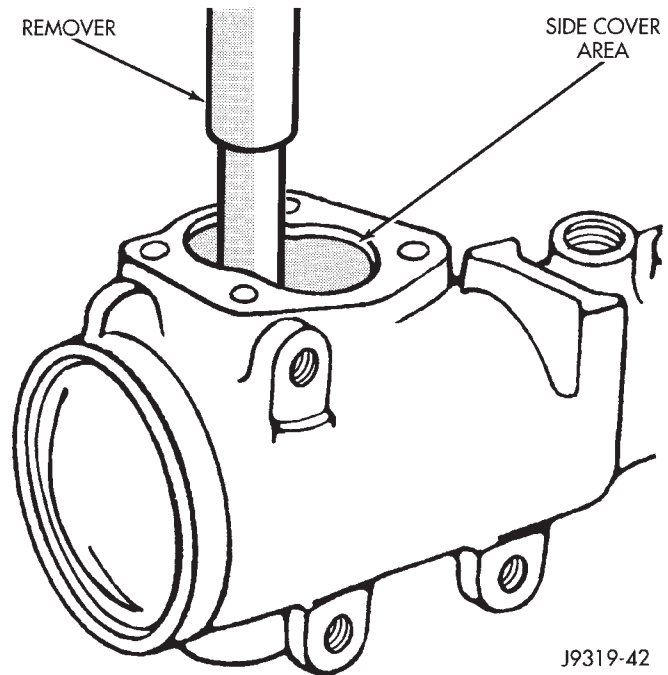


Fig. 10 Needle Bearing Removal

- (5) Install the retainer ring with snap ring pliers.
- (6) Install dust seal with a driver and handle.
- (7) Install pitman shaft to side cover by screwing shaft in until it fully seats to side cover.
- (8) Install preload adjuster nut. **Do not tighten nut until after Over-Center Rotation Torque adjustment has been made.**
- (9) Install gasket to side cover and bend tabs around edges of side cover (Fig. 8).
- (10) Install pitman shaft assembly and side cover to housing.
- (11) Install side cover bolts and tighten to 60 N·m (44 ft. lbs.).
- (12) Adjust Over-Center Rotation Torque.

DISASSEMBLY AND ASSEMBLY (Continued)

SPOOL VALVE

DISASSEMBLY

- (1) Remove lock nut (Fig. 11).
- (2) Remove adjuster nut with Spanner Wrench C-4381.
- (3) Remove thrust support assembly out of the housing (Fig. 12).
- (4) Pull stub shaft and valve assembly from the housing (Fig. 13).

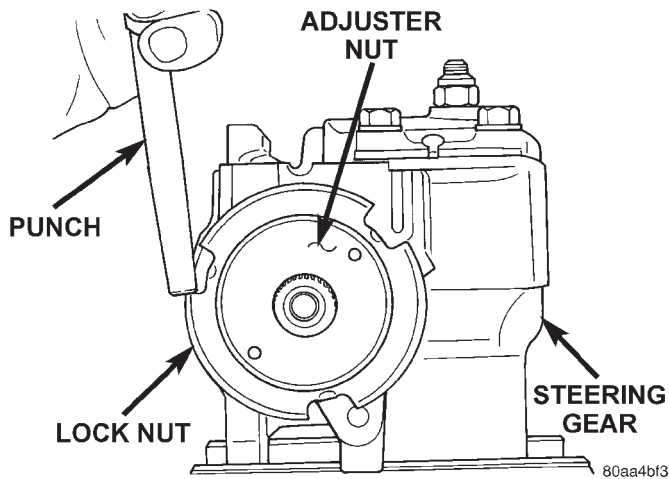


Fig. 11 Lock Nut and Adjuster Nut

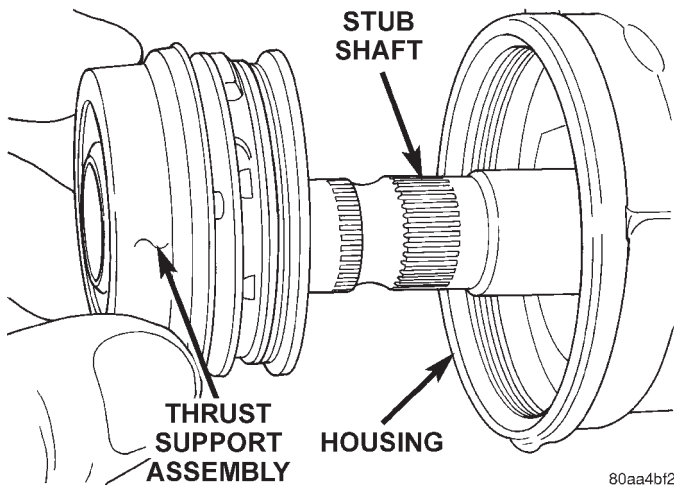
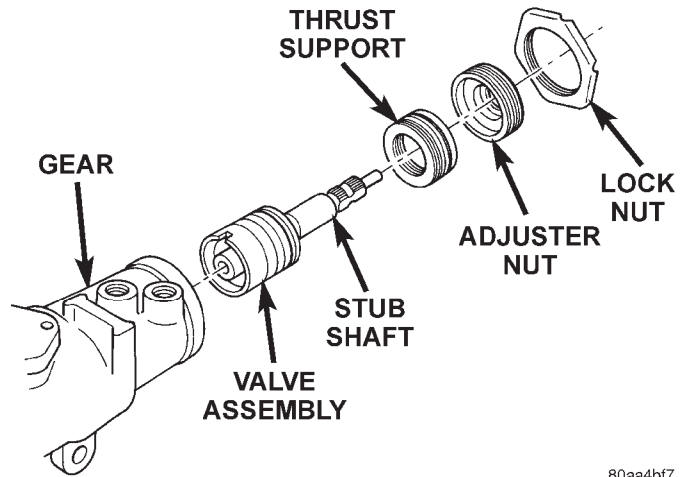


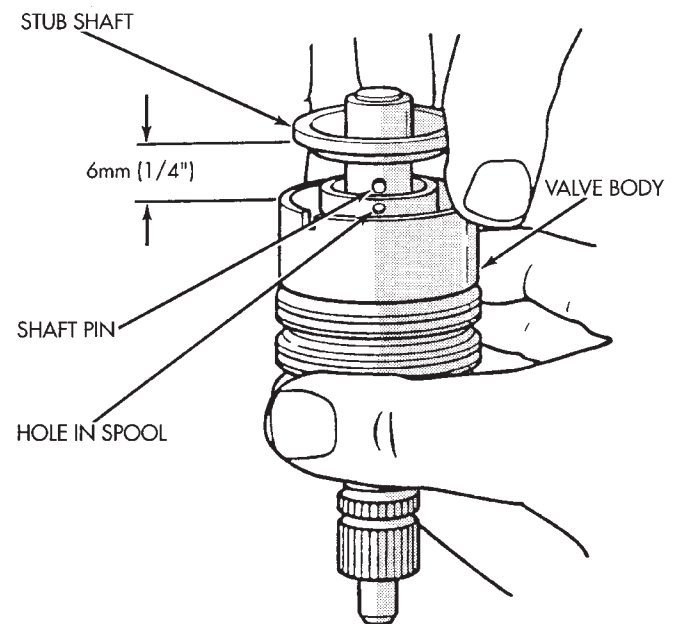
Fig. 12 Thrust Support Assembly



80aa4bf7

Fig. 13 Valve Assembly With Stub Shaft

- (5) Remove stub shaft from valve assembly by lightly tapping shaft on a block of wood to loosen shaft. Then disengage stub shaft pin from hole in spool valve and separate the valve assembly from stub shaft (Fig. 14).



J9319-36

Fig. 14 Stub Shaft

DISASSEMBLY AND ASSEMBLY (Continued)

(6) Remove spool valve from valve body by pulling and rotating the spool valve from the valve body (Fig. 15).

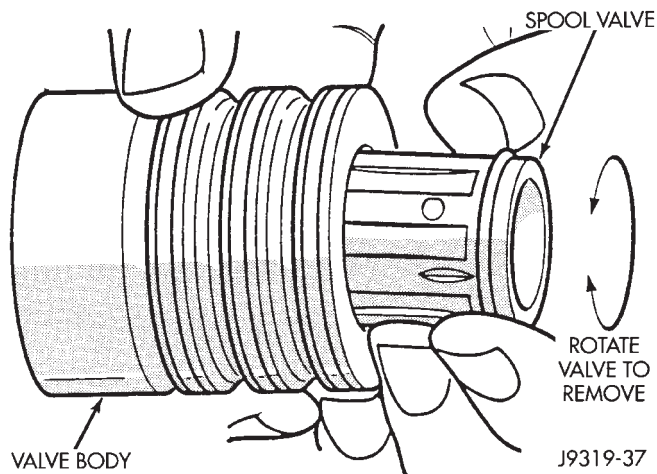


Fig. 15 Spool Valve

(7) Remove spool valve O-ring and valve body teflon rings and O-rings underneath the teflon rings (Fig. 16).

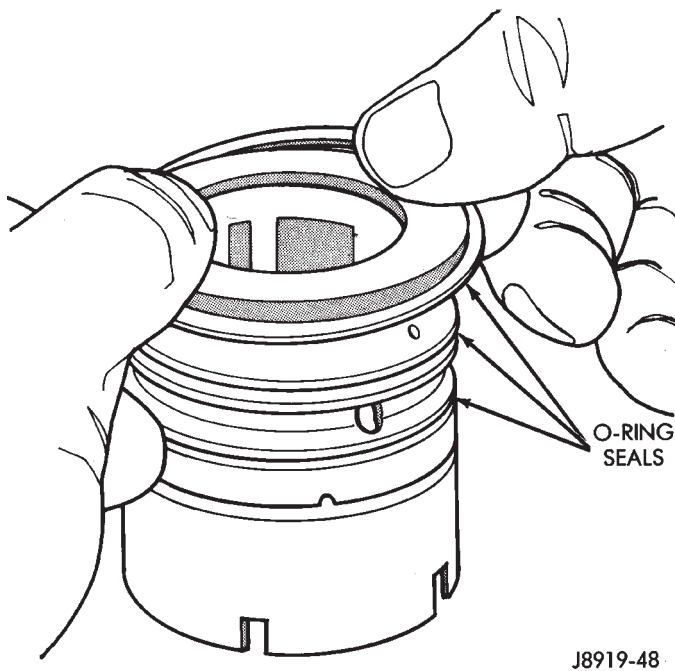


Fig. 16 Valve Seals

(8) Remove the O-ring between the worm shaft and the stub shaft.

ASSEMBLY

NOTE: Clean and dry all components, then lubricate with power steering fluid.

(1) Install spool valve spool O-ring.

(2) Install spool valve in valve body by pushing and rotating. Hole in spool valve for stub shaft pin must be accessible from opposite end of valve body.

(3) Install stub shaft in valve spool and engage locating pin on stub shaft into spool valve hole (Fig. 17).

NOTE: Notch in stub shaft cap must fully engage valve body pin and seat against valve body shoulder.

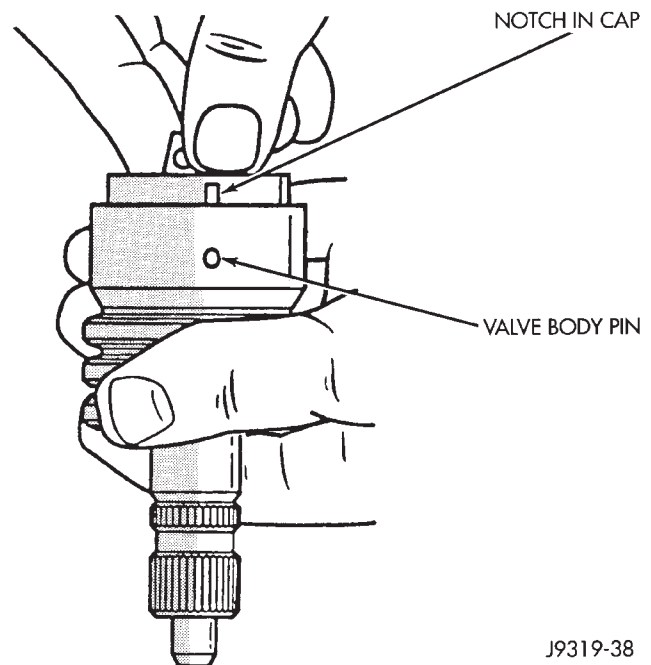


Fig. 17 Stub Shaft Installation

(4) Install O-rings and teflon rings over the O-rings on valve body.

(5) Install O-ring into the back of the stub shaft cap (Fig. 18).

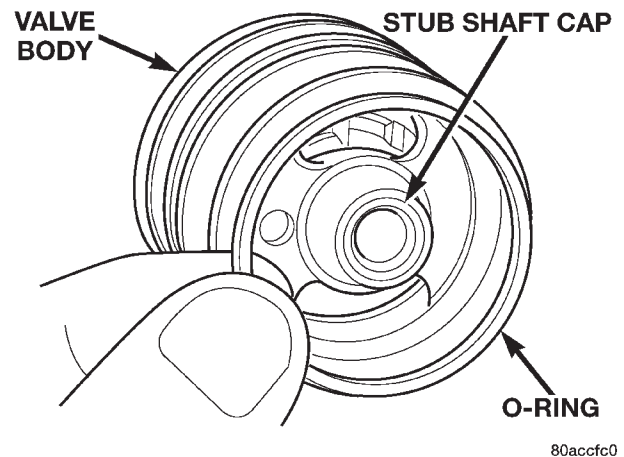


Fig. 18 Stub Shaft Cap O-Ring

DISASSEMBLY AND ASSEMBLY (Continued)

- (6) Install stub shaft and valve assembly in the housing. Line up worm shaft to slots in the valve assembly.
- (7) Install thrust support assembly.

NOTE: The thrust support is serviced as an assembly. If any component of the thrust support is damaged the assembly must be replaced.

- (8) Install adjuster nut and lock nut.
- (9) Adjust Thrust Bearing Preload and Over-Center Rotating Torque.

RACK PISTON AND WORM SHAFT

DISASSEMBLY

- (1) Remove housing end plug.
- (2) Remove rack piston plug (Fig. 19).
- (3) Remove side cover and pitman shaft.

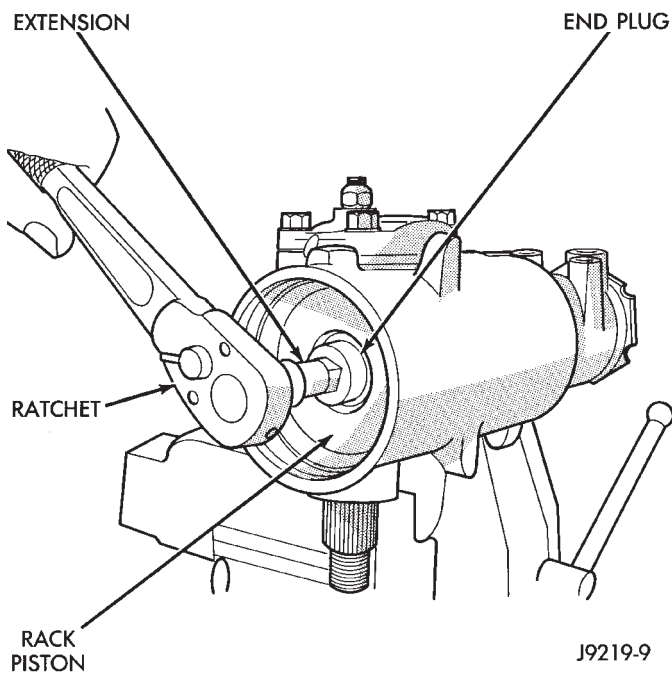


Fig. 19 Rack Piston End Plug

- (4) Turn stub shaft COUNTERCLOCKWISE until the rack piston begins to come out of the housing.
- (5) Insert Arbor C-4175 into bore of rack piston (Fig. 20) and hold tool tightly against worm shaft.
- (6) Turn the stub shaft with a 12 point socket COUNTERCLOCKWISE, this will force the rack piston onto the tool and hold the rack piston balls in place.
- (7) Remove the rack piston and tool together from housing.
- (8) Remove tool from rack piston.
- (9) Remove rack piston balls.
- (10) Remove clamp bolts, clamp and ball guide (Fig. 21).
- (11) Remove teflon ring and O-ring from the rack piston (Fig. 22).

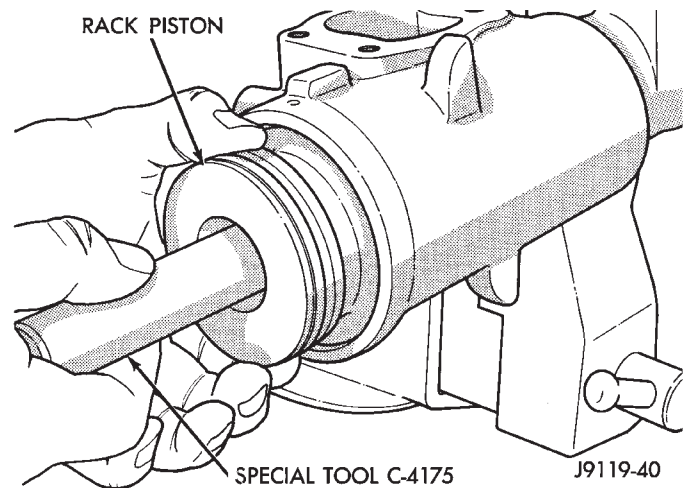


Fig. 20 Rack Piston with Arbor

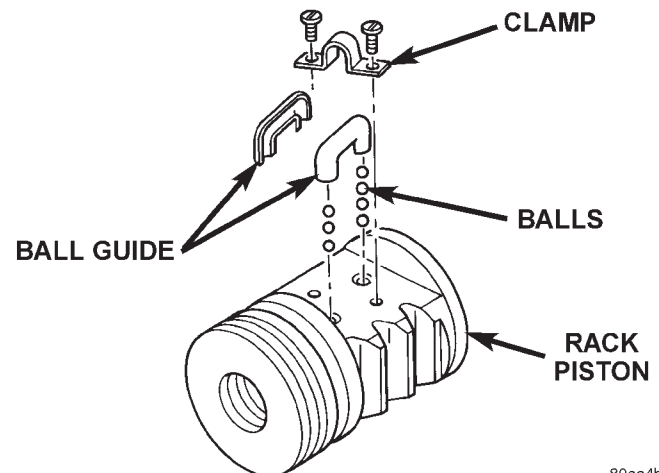


Fig. 21 Rack Piston

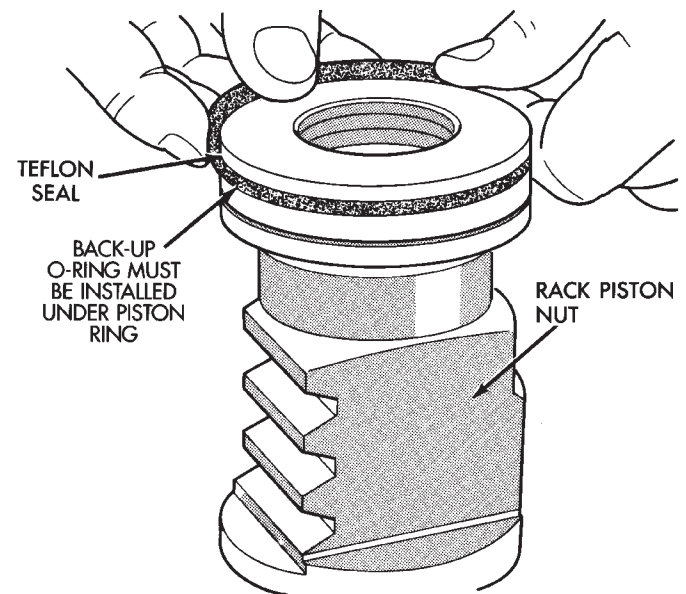


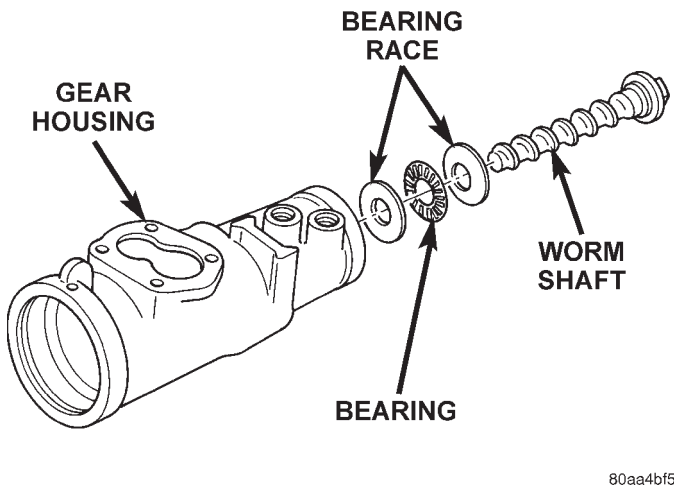
Fig. 22 Rack Piston Teflon Ring and O-Ring

DISASSEMBLY AND ASSEMBLY (Continued)

(12) Remove the adjuster lock nut and adjuster nut from the stub shaft.

(13) Pull the stub shaft with the spool valve and thrust support assembly out of the housing.

(14) Remove the worm shaft from the housing (Fig. 23).



80aa4bf5

Fig. 23 Worm Shaft

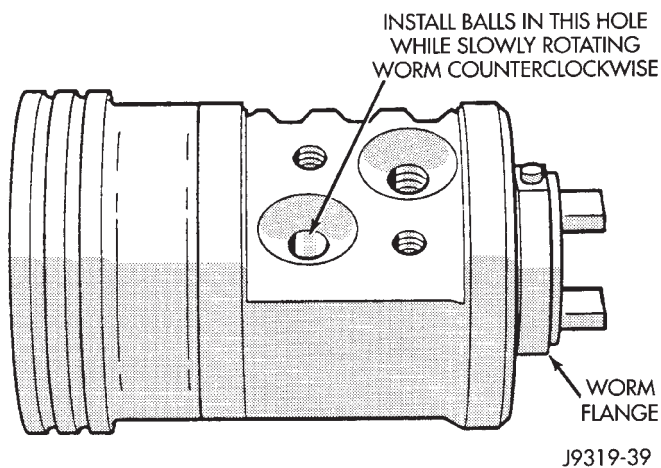
ASSEMBLY

NOTE: Clean and dry all components and lubricate with power steering fluid.

(1) Check for scores, nicks or burrs on the rack piston finished surface. Slight wear is normal on the worm gear surfaces.

(2) Install O-ring and teflon ring on the rack piston.

(3) Install worm shaft in the rack piston and align worm shaft spiral groove with rack piston ball guide hole (Fig. 24).



J9319-39

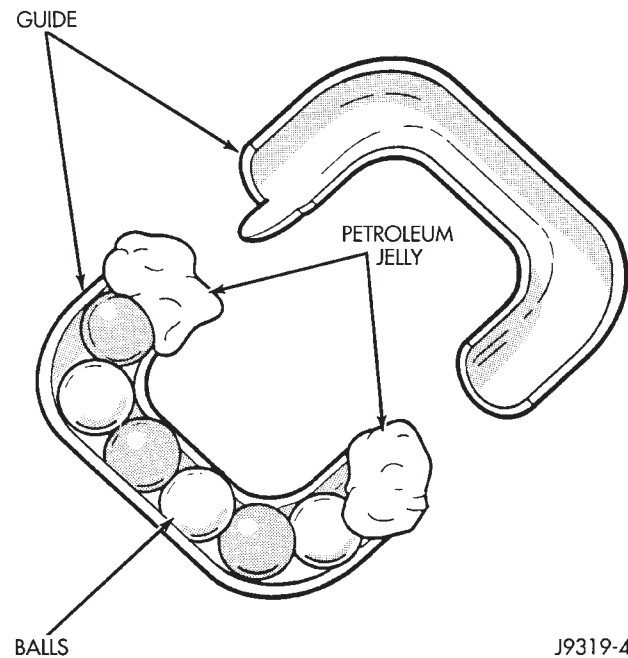
Fig. 24 Installing Balls in Rack Piston

CAUTION: The rack piston balls must be installed alternately into the rack piston and ball guide. This

maintains worm shaft preload. There are 12 black balls and 12 silver (Chrome) balls. The black balls are smaller than the silver balls.

(4) Lubricate and install rack piston balls through return guide hole while turning worm shaft COUNTERCLOCKWISE (Fig. 24).

(5) Install remaining balls in guide using grease to hold the balls in place (Fig. 25).



J9319-40

Fig. 25 Balls in the Return Guide

(6) Install the guide onto rack piston and install clamp and clamp bolts. Tighten bolts to 58 N·m (43 ft. lbs.).

(7) Insert Arbor C-4175 into bore of rack piston and hold tool tightly against worm shaft.

(8) Turn the worm shaft COUNTERCLOCKWISE while pushing on the arbor. This will force the rack piston onto the arbor and hold the rack piston balls in place.

(9) Install the races and thrust bearing on the worm shaft and install shaft in the housing (Fig. 23).

(10) Install the stub shaft with spool valve, thrust support assembly and adjuster nut in the housing.

(11) Install the rack piston and arbor tool into the housing.

(12) Hold arbor tightly against worm shaft and turn stub shaft CLOCKWISE until rack piston is seated on worm shaft.

(13) Install pitman shaft and side cover in the housing.

(14) Install rack piston plug and tighten to 150 N·m (111 ft. lbs.).

(15) Install housing end plug.

DISASSEMBLY AND ASSEMBLY (Continued)

(16) Adjust worm shaft thrust bearing preload and over-center rotating torque.

ADJUSTMENTS

STEERING GEAR

CAUTION: Steering gear must be adjusted in the proper order. If adjustments are not performed in order, gear damage and improper steering response may result.

NOTE: Adjusting the steering gear in the vehicle is not recommended. Remove gear from the vehicle and drain the fluid. Then mount gear in a vise to perform adjustments.

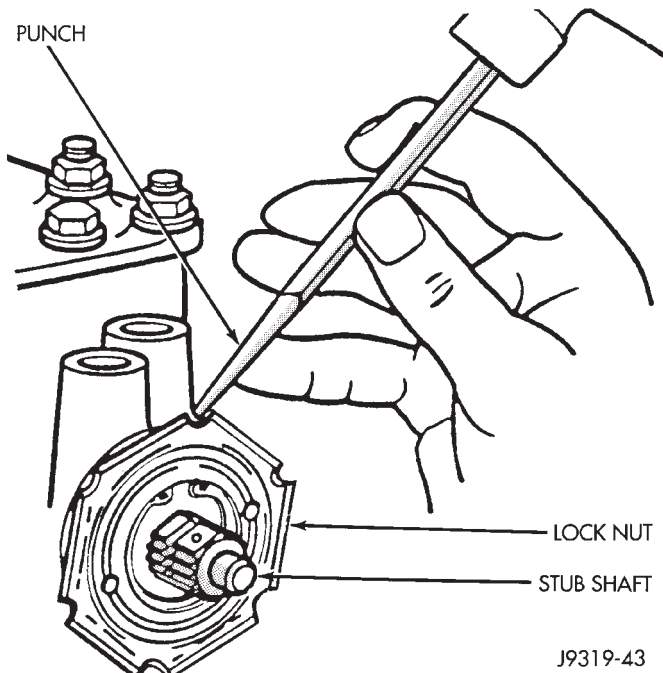
WORM THRUST BEARING PRELOAD

(1) Mount the gear carefully into a vise.

CAUTION: Do not overtighten the vise on the gear case. This may affect the adjustment

(2) Remove adjuster plug locknut (Fig. 26).

(3) Rotate the stub shaft back and forth with a 12 point socket to drain the remaining fluid.

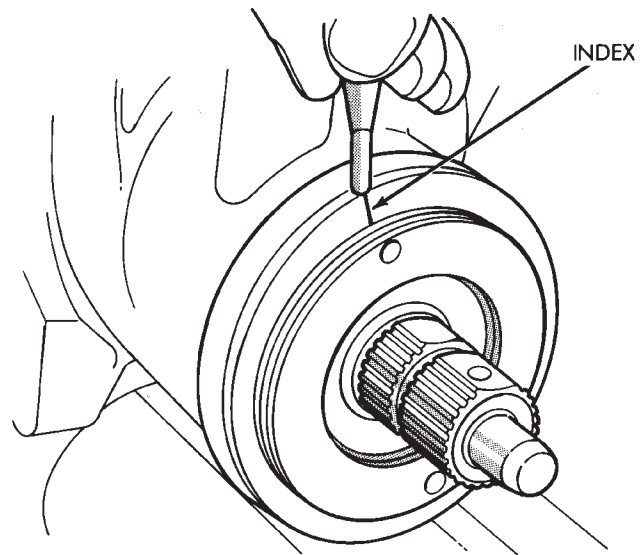


J9319-43

Fig. 26 Loosening the Adjuster Plug

(4) Turn the adjuster in with Spanner Wrench C-4381. Tighten the plug and thrust bearing in the housing until firmly bottomed in the housing about 34 N·m (25 ft. lbs.).

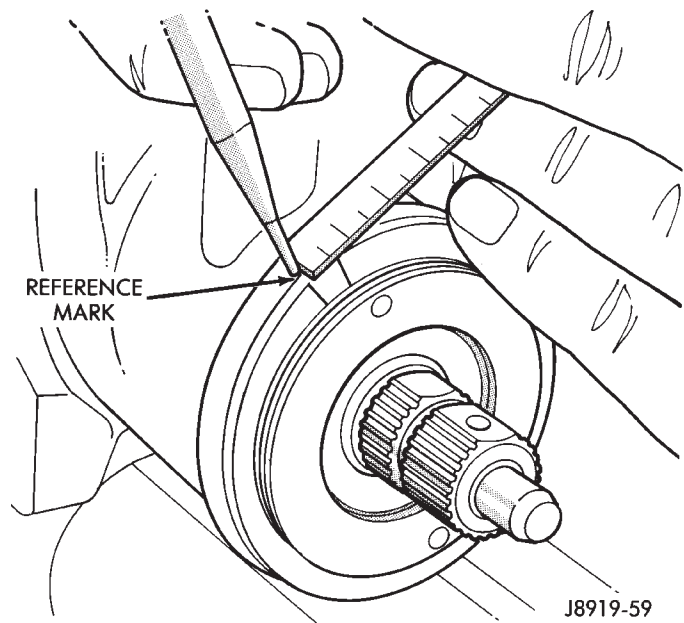
(5) Place an index mark on the housing even with one of the holes in adjuster plug (Fig. 27).



J8919-58

Fig. 27 Alignment Marking On Housing

(6) Measure back (counterclockwise) 10 mm (0.40 in) and mark housing (Fig. 28).

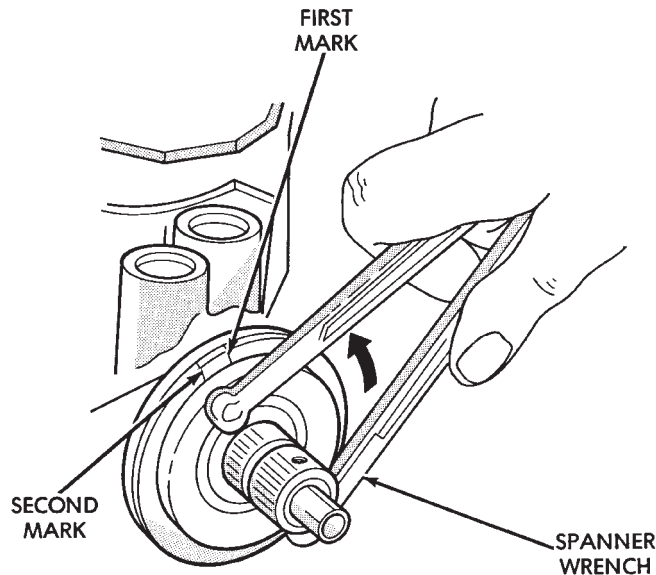


J8919-59

Fig. 28 Second Marking On Housing

ADJUSTMENTS (Continued)

(7) Rotate adjustment cap back (counterclockwise) with spanner wrench until hole is aligned with the second mark (Fig. 29).



J9219-30

Fig. 29 Aligning To The Second Mark

(8) Install and tighten locknut to 108 N·m (80 ft. lbs.). Be sure adjustment cap does not turn while tightening the locknut.

OVER-CENTER

NOTE: Before performing this procedure, the worm bearing preload adjustment must be performed.

(1) Rotate the stub shaft with a 12 point socket from stop to stop and count the number of turns.

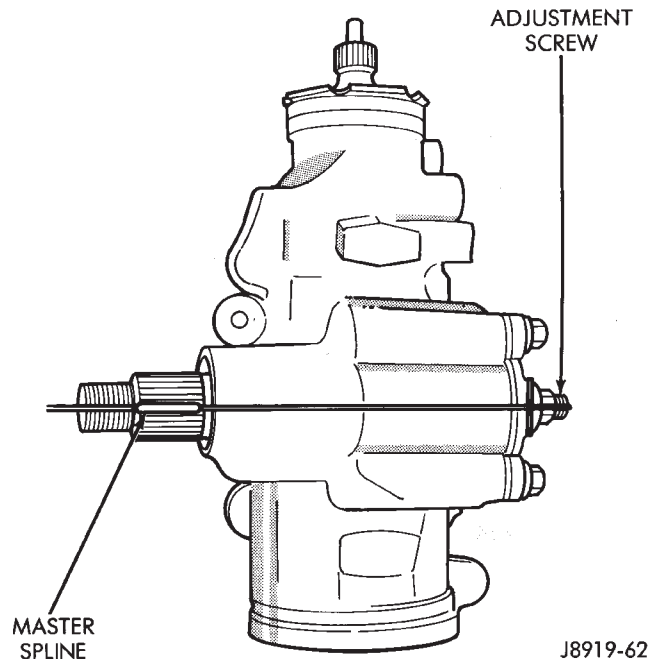
(2) Starting at either stop, turn the stub shaft back 1/2 the total number of turns. This is the center of the gear travel (Fig. 30).

(3) Place the torque wrench in the vertical position on the stub shaft. Rotate the wrench 45 degrees each side of the center and record the highest rotational torque in this range (Fig. 31). This is the Over-Center Rotating Torque.

NOTE: The stub shaft must rotate smoothly without sticking or binding.

(4) Rotate the stud shaft between 90° and 180° to the left of center and record the left off-center preload. Repeat this to the right of center and record the right off-center preload. The average of these two recorded readings is the Preload Rotating Torque.

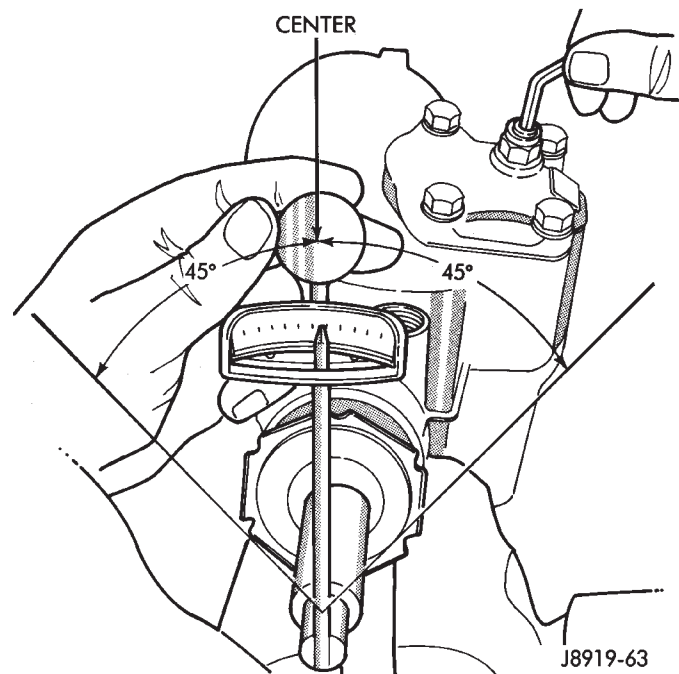
(5) The Over-Center Rotating Torque should be 0.45-0.9 N·m (4-8 in. lbs.) **higher** than the Preload Rotating Torque.



J8919-62

Fig. 30 Steering Gear Centered

(6) If an adjustment to the Over-Center Rotating Torque is necessary, first loosen the adjuster lock nut. Then turn the pitman shaft adjuster screw back (COUNTERCLOCKWISE) until fully extended, then turn back in (CLOCKWISE) one full turn.



J8919-63

Fig. 31 Checking Over-center Rotation Torque

(7) Remeasure Over-Center Rotating Torque. If necessary turn the adjuster screw and repeat measurement until correct Over-Center Rotating Torque is reached.

ADJUSTMENTS (Continued)

NOTE: To increase the Over-Center Rotating Torque turn the screw **CLOCKWISE**.

(8) Prevent the adjuster screw from turning while tightening adjuster lock nut. Tighten the adjuster lock nut to 49 N·m (36 ft. lbs.).

SPECIFICATIONS

POWER STEERING GEAR

Steering Gear

TypeRecirculating Ball
 Gear Ratio12.7:1

Worm Shaft Bearing

Preload0.45-1.13 N·m (4-10 in. lbs.)

Pitman Shaft Overcenter Drag

New Gear (under 400 miles)0.45-0.90 N·m
 (4-8 in. lbs.) + Worm Shaft Preload
 Used Gear (over 400 miles).0.5-0.6 N·m
 (4-5 in. lbs.) + Worm Shaft Preload

TORQUE CHART

DESCRIPTION

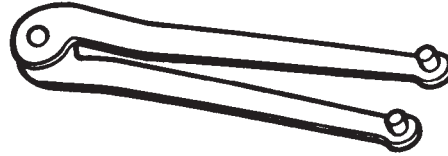
TORQUE

Power Steering Gear

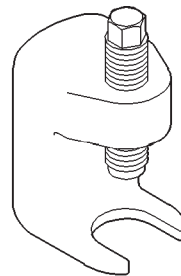
Adjustment Cap Locknut108 N·m (80 ft. lbs.)
 Adjustment Screw Locknut49 N·m (36 ft. lbs.)
 Gear to Frame Bolts88 N·m (65 ft. lbs.)
 Pitman Shaft Nut251 N·m (185 ft. lbs.)
 Rack Piston Plug150 N·m (111 ft. lbs.)
 Side Cover Bolts60 N·m (44 ft. lbs.)
 Pressure Line28 N·m (21 ft. lbs.)
 Return Line28 N·m (21 ft. lbs.)
 Return Guide Clamp Bolt58 N·m (43 ft. lbs.)

SPECIAL TOOLS

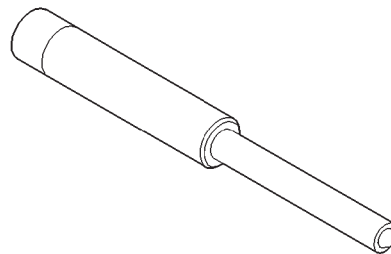
POWER STEERING GEAR



Remover/Installer, Steering Plug C-4381



Remover, Pitman Arm C-4150A



Remover/Installer Steering Rack Piston C-4175

STEERING COLUMN

INDEX

	page		page
GENERAL INFORMATION		REMOVAL AND INSTALLATION	
STEERING COLUMN	20	STEERING COLUMN	22
DIAGNOSIS AND TESTING		SPECIFICATIONS	
IGNITION SWITCH	21	TORQUE CHART	23

GENERAL INFORMATION

STEERING COLUMN

The tilt column (Fig. 1) has been designed to be serviced as an assembly, less the wiring, switches, shrouds, steering wheel, etc. Most steering column components can be serviced without removing the steering column from the vehicle.

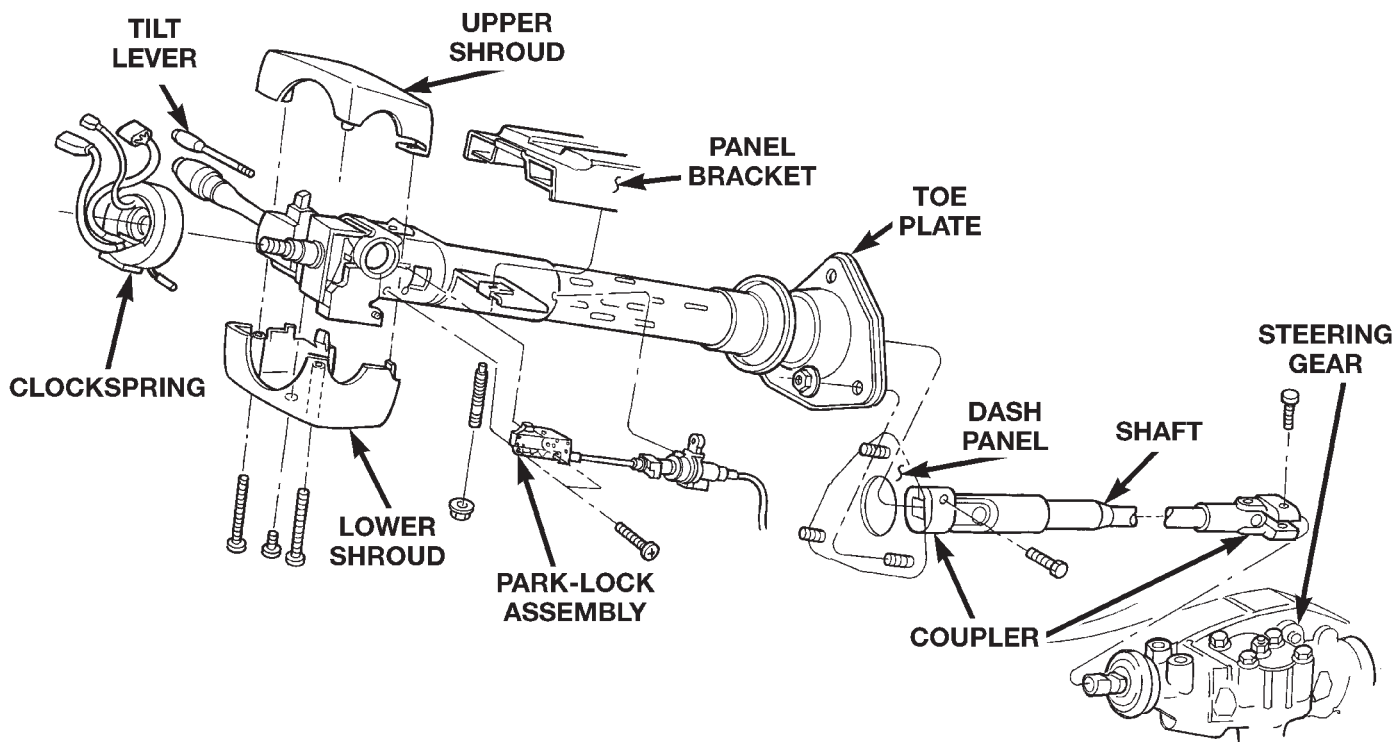
SERVICE PRECAUTIONS

Safety goggles should be worn at all times when working on steering columns.

To service the steering wheel, switches or airbag, refer to Group 8M and follow all WARNINGS and CAUTIONS.

WARNING: THE AIRBAG SYSTEM IS A SENSITIVE, COMPLEX ELECTRO-MECHANICAL UNIT. BEFORE

ATTEMPTING TO DIAGNOSE, REMOVE OR INSTALL THE AIRBAG SYSTEM COMPONENTS YOU MUST FIRST DISCONNECT AND ISOLATE THE BATTERY NEGATIVE (GROUND) CABLE. THEN WAIT TWO MINUTES FOR THE SYSTEM CAPACITOR TO DISCHARGE. FAILURE TO DO SO COULD RESULT IN ACCIDENTAL DEPLOYMENT OF THE AIRBAG AND POSSIBLE PERSONAL INJURY. THE FASTENERS, SCREWS, AND BOLTS, ORIGINALLY USED FOR THE AIRBAG COMPONENTS, HAVE SPECIAL COATINGS AND ARE SPECIFICALLY DESIGNED FOR THE AIRBAG SYSTEM. THEY MUST NEVER BE REPLACED WITH ANY SUBSTITUTES. ANYTIME A NEW FASTENER IS NEEDED, REPLACE WITH THE CORRECT FASTENERS PROVIDED IN THE SERVICE PACKAGE OR FASTENERS LISTED IN THE PARTS BOOKS.



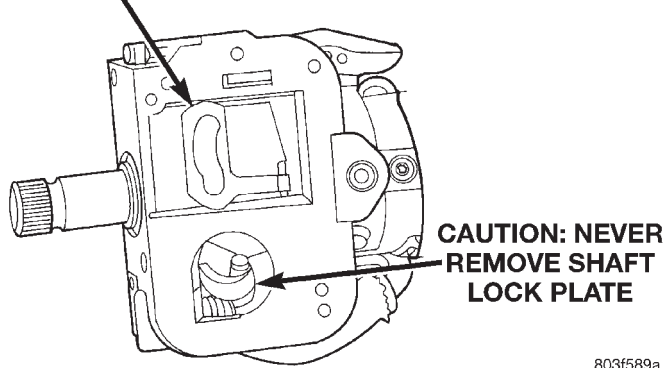
80a53b56

Fig. 1 Steering Column

GENERAL INFORMATION (Continued)

CAUTION: Do not attempt to remove the pivot pins to disassemble the tilting mechanism. Do not remove ignition locking link, shaft lock plate or plate retainer. This will damage the column (Fig. 2) and (Fig. 3).

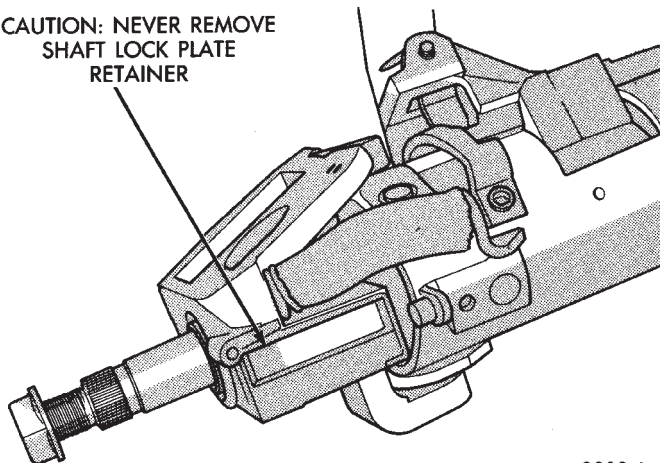
CAUTION: DO NOT REMOVE IGNITION LOCKING LINK



803f589a

Fig. 2 Observe Cautions

CAUTION: NEVER REMOVE SHAFT LOCK PLATE RETAINER



9019-6

Fig. 3 Observe Cautions

DIAGNOSIS AND TESTING

IGNITION SWITCH

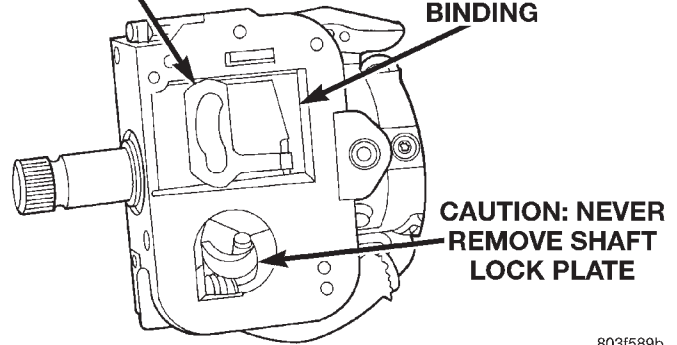
TEST AND REPAIR

If the ignition switch effort is excessive, remove the ignition switch from the steering column. Refer to Group 8D Ignition System. Using a key cylinder, check the turning effort of the switch. If the ignition switch binds look for the following conditions.

(1) Look for rough areas or flash in the casting and if found remove with a file (Fig. 4).

CAUTION: DO NOT REMOVE IGNITION LOCKING LINK

FILE THIS AREA TO REMOVE FLASHING AND PROVIDE CLEARANCE TO ELIMINATE BINDING



803f589b

Fig. 4 Steering Column Flash Removal And Non-Serviceable Components

(2) With the ignition switch removed, slide the slider in its slot in the sleeve and verify a loose fit over the length of the slot. If the slider binds in the slot at any point lightly file the slider or slot until clearance is achieved.

(3) If no binding is found, lightly file the ramp on the ignition switch, (The ramp fits into the casting) until binding no longer occurs.

REMOVAL AND INSTALLATION

STEERING COLUMN

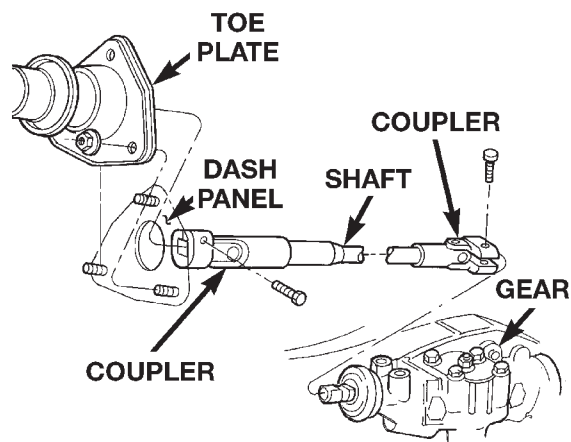
WARNING: BEFORE SERVICING THE STEERING COLUMN THE AIRBAG SYSTEM MUST BE DISARMED. FAILURE TO DO SO MAY RESULT IN ACCIDENTAL DEPLOYMENT OF THE AIRBAG AND POSSIBLE PERSONAL INJURY. REFER TO GROUP 8M RESTRAINT SYSTEMS FOR SERVICE PROCEDURES.

REMOVAL

- (1) Position front wheels straight ahead.
- (2) Disconnect the negative (ground) cable from the battery.
- (3) Remove the airbag, refer to Group 8M Restraint Systems for service procedures.
- (4) Remove the steering wheel with an appropriate puller.

CAUTION: Ensure the puller bolts are fully engaged into the steering wheel and not into the clock-spring, before attempting to remove the wheel. Failure to do so may damage the steering wheel.

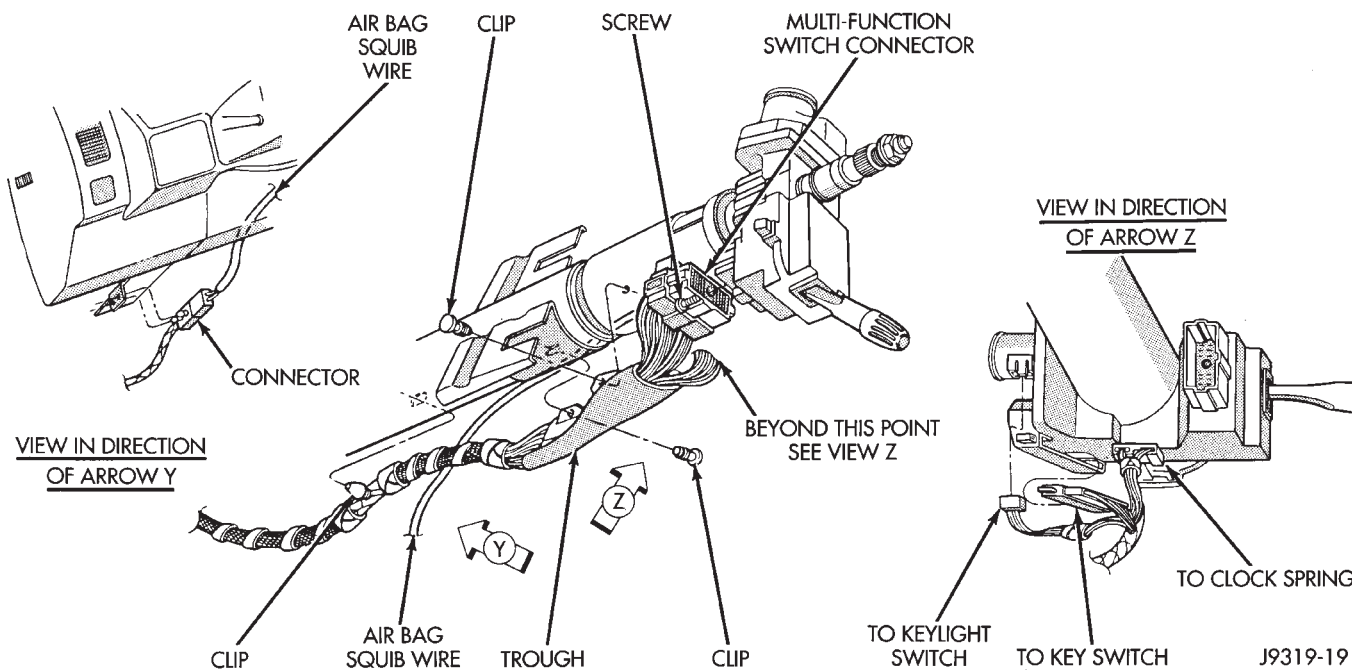
- (5) Remove column coupler upper pinch bolt (Fig. 5).
- (6) Remove the knee blocker, refer to Group 8E Instrument Panel Systems.
- (7) Remove tilt lever from column.



80a5cefe

Fig. 5 Column Coupler Shaft

- (8) Remove the upper and lower lock housing shrouds.
- (9) Loosen the column mounting nut/washer assemblies to allow the column to drop.
- (10) Remove the Interlock cable from the steering column. Refer to Group 21 Transmission and Transfer Case.
- (11) Remove multi-function switch connector screw and remove connector.
- (12) Remove the wiring harness from the remaining switches and the steering column (Fig. 6).
- (13) Remove the ignition switch.
- (14) Remove the clock spring, and switches refer to Group 8 Electrical for service procedures.
- (15) Remove the toe plate to dash panel nuts.



J9319-19

Fig. 6 Steering Column Wiring Harness

REMOVAL AND INSTALLATION (Continued)

(16) Remove the mounting nut/washer assemblies and remove the column.

INSTALLATION

(1) With the front wheels in the straight ahead position. Align and install the column to coupler. **Do not apply force at the top of the steering column shaft.**

(2) Remove the column shaft shipping lock pin (installed in service column).

(3) Ensure the ground clip is on spacer slot.

(4) Install the Interlock cable from the steering column. Refer to Group 21 Transmission and Transfer Case.

(5) Install wiring harness connections to steering column. **Ensure the wiring is not pinched and all connections are correctly locked in place.**

(6) Install the clock spring, and switches refer to Group 8 Electrical for service procedures.

(7) Install the harness connector to the switches.

(8) Install the ignition switch.

(9) Install shaft coupler pinch bolt loose, load column up to panel bracket.

(10) Be sure both spacers are fully seated in the column support bracket. Tighten the column mounting nut/washer assemblies to 12 N·m (105 in. lbs.).

(11) Tighten the toe plate attaching nuts to 12 N·m (105 in. lbs.).

(12) Tighten the coupler pinch bolt to 49 N·m (36 ft. lbs.).

(13) Install the heater cross over tube under the column.

(14) Install the upper and lower shrouds and tilt lever.

(15) Install the knee blocker, refer to Group 8E Instrument Panel Systems

(16) Install the steering wheel and airbag, refer to Group 8M Passive Restraint Systems for procedures.

(17) Connect the battery ground (negative) cable.

SPECIFICATIONS

TORQUE CHART

DESCRIPTION	TORQUE
Steering Column	
Steering Wheel Nut61 N·m (45 ft. lbs.)
Column Bracket Nuts12 N·m (105 in. lbs.)
Shaft Coupler Bolts49 N·m (36 ft. lbs.)
Toe Plate Bolts12 N·m (105 in. lbs.)

STEERING LINKAGE

INDEX

	page		page
GENERAL INFORMATION		STEERING DAMPENER	26
STEERING LINKAGE	24	TIE ROD	25
SERVICE PROCEDURES		SPECIFICATIONS	
STEERING LINKAGE	24	TORQUE CHART	26
REMOVAL AND INSTALLATION		SPECIAL TOOLS	
DRAG LINK	25	STEERING LINKAGE	26
PITMAN ARM	25		

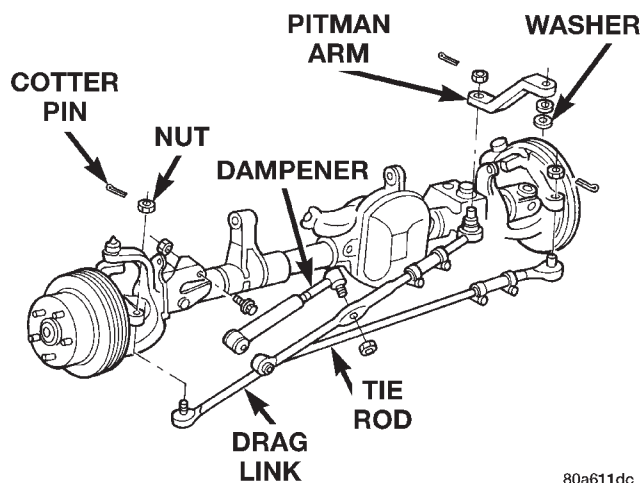
GENERAL INFORMATION

STEERING LINKAGE

The steering linkage consists of a pitman arm, drag link, tie rod, and steering dampener (Fig. 1) and (Fig. 2). Adjustment sleeves are used on the tie rod and drag link for toe and steering wheel alignment.

CAUTION: Components attached with a nut and cotter pin must be torqued to specification. Then if the slot in the nut does not line up with the cotter pin hole, tighten nut until it is aligned. Never loosen the nut to align the cotter pin hole.

NOTE: Periodic lubrication of the steering system components is required. Refer to Group 0, Lubrication And Maintenance for the recommended maintenance schedule.



80a611dc

Fig. 2 Steering Linkage-8 Cylinder Engine

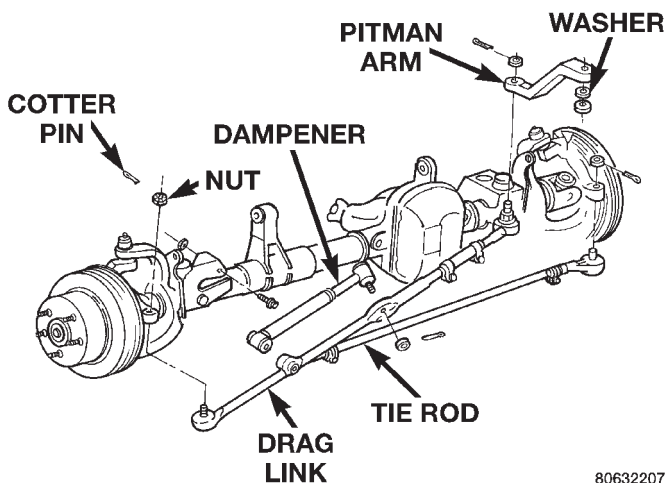
SERVICE PROCEDURES

STEERING LINKAGE

The tie rod end and ball stud seals should be inspected during all oil changes. If a seal is damaged, it should be replaced. Before installing a new seal, inspect ball stud at the throat opening. Check for lubricant loss, contamination, ball stud wear or corrosion. If these conditions exist, replace the tie rod. A replacement seal can be installed if lubricant is in good condition. Otherwise, a complete replacement ball stud end should be installed.

CAUTION: If any steering components are replaced or serviced an alignment must be performed, to ensure the vehicle meets all alignment specifications.

CAUTION: Components attached with a nut and cotter pin must be torqued to specification. Then if the slot in the nut does not line up with the cotter pin hole, tighten nut until it is aligned. Never loosen the nut to align the cotter pin hole.



80632207

Fig. 1 Steering Linkage-6 Cylinder Engine

REMOVAL AND INSTALLATION

TIE ROD

REMOVAL

- (1) Remove the cotter pins and nuts at the steering knuckle and drag link (Fig. 1) and (Fig. 2).
- (2) Loosen the ball studs with a puller tool to remove the tie rod.
- (3) If necessary, loosen the end clamp bolts and remove the tie rod ends from the tube.

INSTALLATION

- (1) If necessary, install the tie rod ends in the tube. Position the tie rod clamp (Fig. 3) and tighten to:

- Drag Link: 49 N·m (36 ft. lbs.)
- Tie Rod-6 Cyl. Engine: 27 N·m (20 ft. lbs.)
- Tie Rod-8 Cyl. Engine: 49 N·m (36 ft. lbs.)

- (2) Install the tie rod on the drag link and steering knuckle. Install the retaining nuts.

- (3) Tighten the ball stud nut on the steering knuckle to 47 N·m (35 ft. lbs.). Tighten the ball stud nut to drag link to 75 N·m (55 ft. lbs.) torque. Install new cotter pins and bend end 60°.

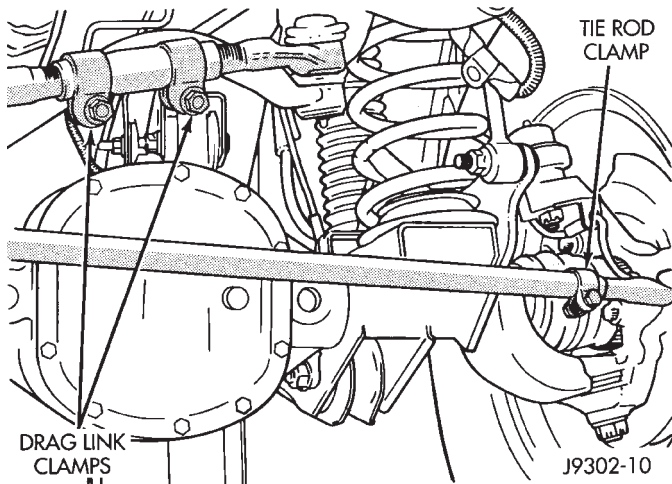
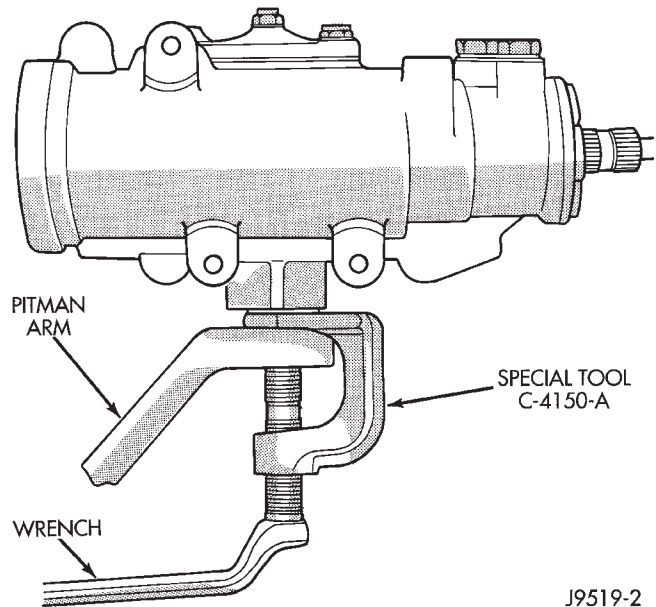


Fig. 3 Tie Rod/Drag Link Clamp Bolt

PITMAN ARM

REMOVAL

- (1) Remove the cotter pin and nut from the drag link at the pitman arm.
- (2) Remove the drag link ball stud from the pitman arm with a puller.
- (3) Remove the nut and washer from the steering gear shaft. Mark the pitman shaft and pitman arm for installation reference. Remove the pitman arm from steering gear with Puller C-4150A (Fig. 4).



J9519-2

Fig. 4 Pitman Arm Removal

INSTALLATION

- (1) Align and install the pitman arm on steering gear shaft.
- (2) Install the washer and nut on the shaft and tighten the nut to 251 N·m (185 ft. lbs.).
- (3) Install drag link ball stud to pitman arm. Install nut and tighten to 81 N·m (60 ft. lbs.). Install a new cotter pin.

DRAG LINK

REMOVAL

- (1) Remove the cotter pins and nuts at the steering knuckle and drag link (Fig. 1).
- (2) Remove the steering dampener ball stud from the drag link with a puller.
- (3) Remove the drag link from the steering knuckle with a puller tool. Remove the same for tie rod and pitman arm.
- (4) If necessary, loosen the end clamp bolts and remove the tie rod end from the link.

INSTALLATION

- (1) Install the drag link adjustment sleeve and tie rod end. Position clamp bolts (Fig. 3).
- (2) Position the drag link at the steering linkage. Install the drag link to the steering knuckle nut. Do the same for the tie rod and pitman arm.
- (3) Tighten the nut at the steering knuckle to 47 N·m (35 ft. lbs.). Tighten the pitman nut to 81 N·m (60 ft. lbs.) and tie rod ball stud nut to 47 N·m (35 ft. lbs.). Install new cotter pins and bend end 60°.

REMOVAL AND INSTALLATION (Continued)

(4) Install the steering dampener onto the drag link and tighten the nut to 74 N·m (55 ft. lbs.). Install a new cotter pin and bend end 60°.

STEERING DAMPENER

REMOVAL

- (1) Place the front wheels in a straight ahead position.
- (2) Remove the steering dampener retaining nut and bolt from the axle bracket (Fig. 1).
- (3) Remove the cotter pin and nut from the ball stud at the drag link.
- (4) Remove the steering dampener ball stud from the drag link using C-3894-A puller.

INSTALLATION

- (1) Install the steering dampener to the axle bracket and drag link.
- (2) Install the steering dampener bolt in the axle bracket and tighten nut to 74 N·m (55 ft. lbs.).
- (3) Install the ball stud nut at the drag link and tighten nut to 74 N·m (55 ft. lbs.). Install a new cotter pin.

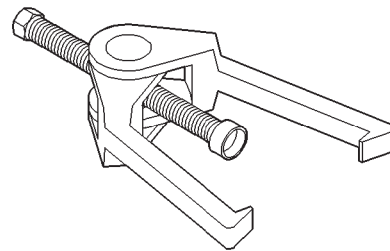
SPECIFICATIONS

TORQUE CHART

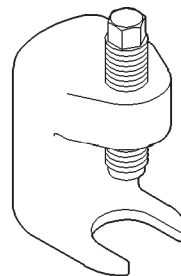
DESCRIPTION	TORQUE
Pitman Arm	
Shaft Nut251 N·m (185 ft. lbs.)
Drag Link	
Pitman Arm Nut81 N·m (60 ft. lbs.)
Knuckle Nut47 N·m (35 ft. lbs.)
Clamp Bolts.49 N·m (36 ft. lbs.)
Tie Rod Ends	
4.0L Clamp Bolts.27 N·m (20 ft. lbs.)
5.2L Clamp Bolts.49 N·m (36 ft. lbs.)
Tie Rod	
Knuckle Nut47 N·m (35 ft. lbs.)
Drag Link Nut75 N·m (55 ft. lbs.)
Steering Damper	
Frame Bolt74 N·m (55 ft. lbs.)
Drag Link Nut.74 N·m (55 ft. lbs.)

SPECIAL TOOLS

STEERING LINKAGE



Puller C-3894-A



Remover Pitman C-4150A

STEERING

CONTENTS

	page		page
POWER STEERING PUMP	1	SPEED PROPORTIONAL STEERING	3

POWER STEERING PUMP

INDEX

page

REMOVAL AND INSTALLATION

POWER STEERING PUMP—2.5L DIESEL 1

REMOVAL AND INSTALLATION

POWER STEERING PUMP—2.5L DIESEL

NOTE: The power steering pump is mounted below the fuel pump on the left side of the engine. The vehicle should be raised on a hoist to access the pump from below.

REMOVAL

- (1) Remove bolt securing A/C line retainer bracket to top of the valve cover.
- (2) Remove serpentine drive belt. Refer to Group 7, Cooling System, for procedure.
- (3) Remove power steering pump pulley. Use a hex wrench to secure the power steering shaft while removing the pulley bolt with a box wrench. (Fig. 1).

CAUTION: Do not use an impact wrench to remove the pump pulley – this can cause rear pump seal damage. Do not secure power steering shaft with a wrench on the 'H' coupling to the A/C compressor – this can cause rear pump seal damage.

- (4) Remove 'H' coupling power steering pump shaft pinch bolt.
- (5) Remove 'H' coupling bolts (2) from power steering pump side of coupling.

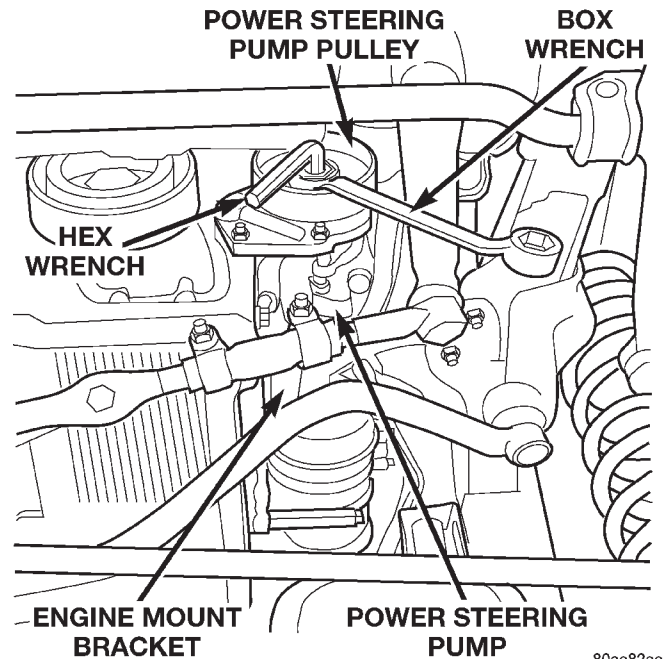


Fig. 1 Power Steering Pump Pulley Removal

- (6) Remove 'H' coupling bolts (2) from A/C compressor side of coupling.
- (7) Loosen A/C compressor bolts and separate compressor from bracket. Do not disconnect A/C hoses.
- (8) Remove left engine mount bracket bolts (4).

REMOVAL AND INSTALLATION (Continued)

(9) Remove left motor mount frame bracket (Fig. 2). Refer to Group 9, Engine, for procedure.

NOTE: Some engine mounts are welded to the frame bracket, and cannot be separated from the bracket. In this case, it may be necessary to remove the steering shaft on LHD vehicles to be able to remove the bracket.

(10) Remove bolts (2) securing the power steering pump to the power steering bracket.

(11) Disconnect power steering pump supply hose at the pump and drain fluid.

(12) Disconnect power steering pressure hose at the steering gear assembly.

(13) Remove power steering pump.

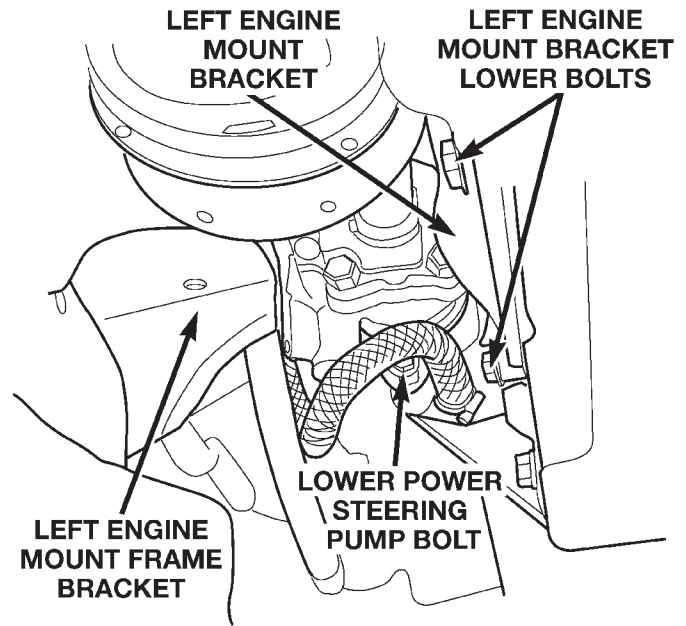
INSTALLATION

(1) Install pump on engine.

(2) Tighten pump bracket bolts to 47 N·m (35 ft. lbs.).

(3) Reverse the above procedures in steps 12 through 1 to complete installation.

(4) Add power steering fluid and perform Power Steering Pump Initial Operation.



80ae82ed

Fig. 2 Left Side Motor Mount—VM Diesel

SPEED PROPORTIONAL STEERING

INDEX

	page		page
DESCRIPTION AND OPERATION		DIAGNOSIS AND TESTING	
POWER STEERING GEAR	4	SPEED PROPORTIONAL STEERING	4
SPEED PROPORTIONAL STEERING CONTROL MODULE	3	REMOVAL AND INSTALLATION	
SPEED PROPORTIONAL STEERING SOLENOID	4	SPEED PROPORTIONAL STEERING CONTROL MODULE	5
SPEED PROPORTIONAL STEERING	3	STEERING WHEEL SPEED SENSOR	4
STEERING WHEEL SPEED SENSOR	4		

DESCRIPTION AND OPERATION

SPEED PROPORTIONAL STEERING

Speed Proportional Steering consist of;

- Speed Proportional Steering Control Module (SPSCM)
- Steering Wheel Speed Sensor (SWSS)
- Speed Proportional Steering Solenoid (SPSS)
- Speed Proportional Steering Gear (SPSG)

Speed Proportional Steering provides variable power assist based on inputs from the Vehicle Speed Sensor and Steering Wheel Speed Sensor. The sensors are monitored by the Speed Proportional Steering Control Module. The module controls the operation of the Speed Proportional Steering Solenoid which regulated power steering pump flow rate.

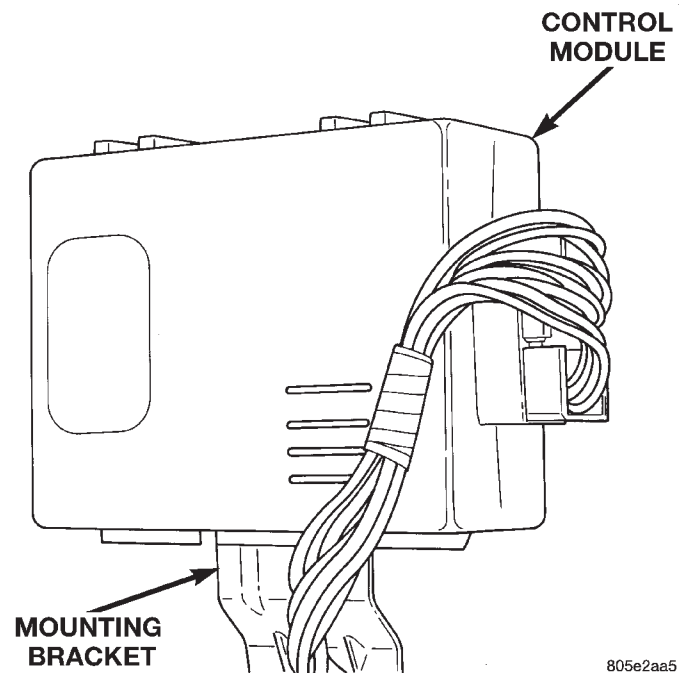
When parking or at low speeds, full power assist is provided. As the vehicle speed increases pump flow is reduced. This reduces the power assist, providing the driver with a better steering feel for the road and improved directional stability.

The SWSS continually monitors steering wheel assist. When a quick steering maneuver is made while the system is operating at reduced power assist, full assist is provided for the maneuver instantly.

SPEED PROPORTIONAL STEERING CONTROL MODULE

The control module is mounted to a bracket on the passenger side of the front cowl panel just left of the

steering column (Fig. 1). A 14-way connector is attached to the module. The module monitors steering wheel speed and vehicle speed to determine the amount of power steering assist needed. The module controls power steering assist by sending a 12-volt duty-cycle signal (pulsed on and off) to the Speed Proportional Steering Solenoid.



805e2aa5

Fig. 1 Speed Proportional Steering Control Module

DESCRIPTION AND OPERATION (Continued)**STEERING WHEEL SPEED SENSOR**

The Steering Wheel Speed Sensor is mounted on the steering column shaft below the clock spring (Fig. 2). The sensor is used to monitor steering wheel assist.

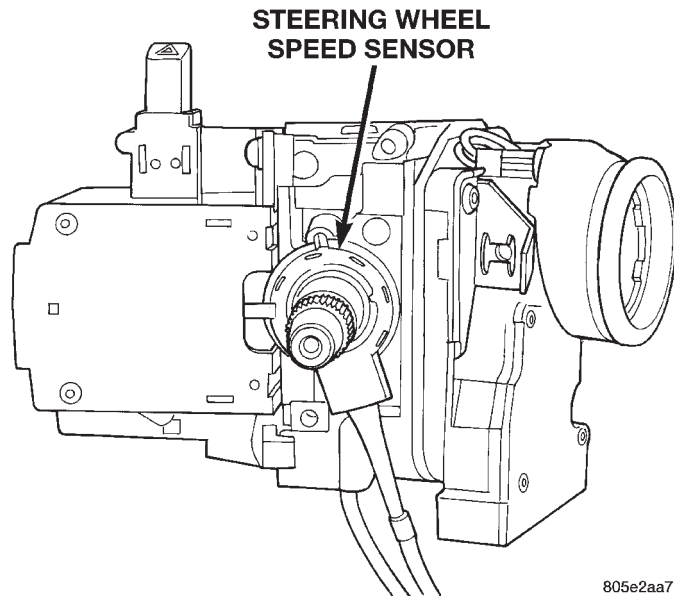


Fig. 2 Steering Wheel Speed Sensor

SPEED PROPORTIONAL STEERING SOLENOID

The solenoid is mounted to the power steering pump outlet port (Fig. 3). The solenoid controls pump output volume by moving a metering rod in and out of a fixed orifice. The SPSCM energizes and de-energizes the solenoid to move the metering rod up to 250 times per second. By varying the time energized versus de-energize steering pump output volume and steering assist is controlled.

POWER STEERING GEAR

The steering gear used with Speed Proportional Steering has a special spool valve. The valve provides improved response at lower flow rates. The gear is a serviceable component.

CAUTION: A Speed Proportional Steering gear should not be interchanged with any other steering gear.

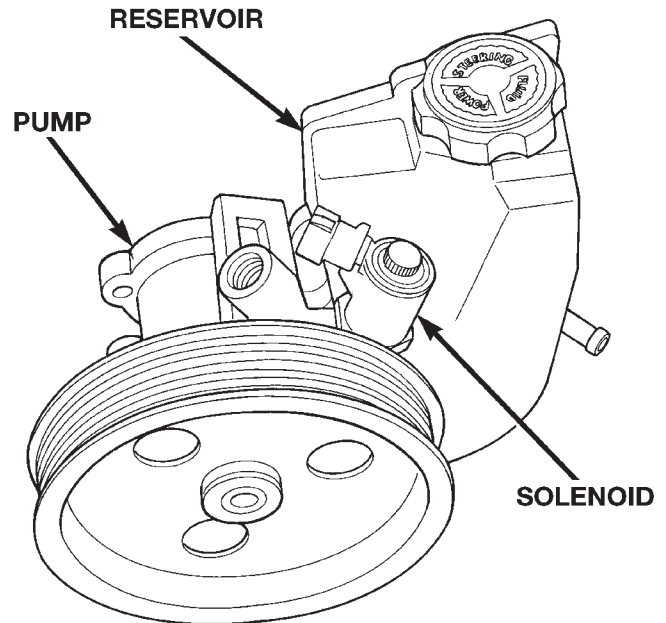


Fig. 3 Speed Proportional Steering Solenoid

DIAGNOSIS AND TESTING**SPEED PROPORTIONAL STEERING**

For diagnosis and testing procedures refer to the Chassis Diagnostic Manual.

REMOVAL AND INSTALLATION**STEERING WHEEL SPEED SENSOR****REMOVAL**

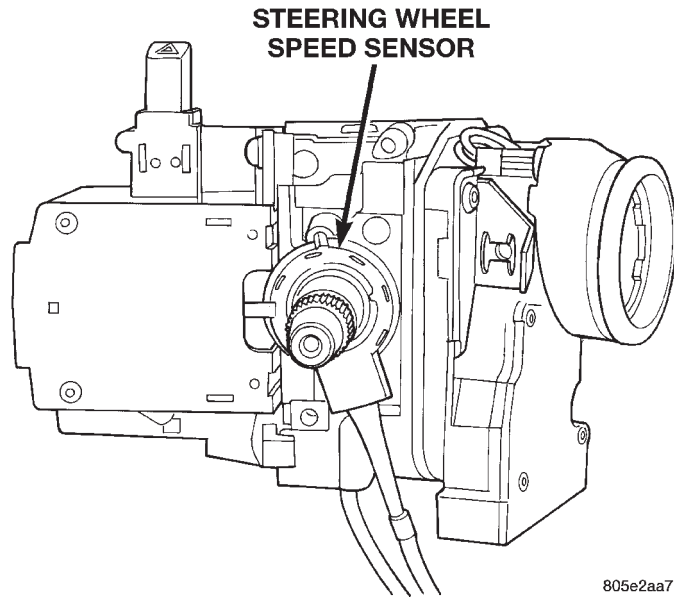
- (1) Disconnect the negative (ground) cable from the battery.
- (2) Remove airbag, refer to Group 8M Electrical for procedure.
- (3) Remove steering wheel with appropriate puller.
- (4) Remove clock spring, refer to Group 8M Electrical for procedure.
- (5) Pry sensor retaining ring tabs up and remove sensor (Fig. 4).

INSTALLATION

CAUTION: Never install a used sensor. Once the sensor has been removed it must be replaced with a new sensor.

- (1) Install new sensor on column shaft with a piece of thin wall conduit 3 inch long by 3/4 inch ID. Move turn signal canceller off to one side and insure locating tab is in the proper position and push the sensor down on the shaft.

REMOVAL AND INSTALLATION (Continued)



805e2aa7

Fig. 4 Steering Wheel Speed Sensor

CAUTION: The pipe installer must only touch the inner metal ring of the sensor and not the plastic housing or the sensor will be damaged.

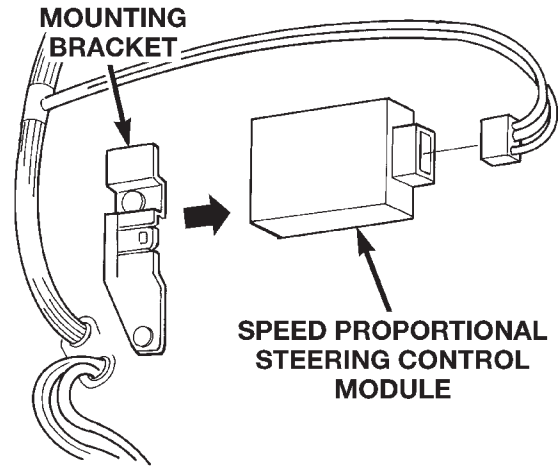
- (2) Install clock spring, refer to Group 8M Electrical for procedure.
- (3) Install steering wheel.
- (4) Install airbag, refer to Group 8M Electrical for procedure.

- (5) Connect negative (ground) cable to the battery.

SPEED PROPORTIONAL STEERING CONTROL MODULE

REMOVAL

- (1) Unplug harness from control module, located left of steering column on front cowl panel.
- (2) Slid the module off mounting bracket (Fig. 5).



80632208

Fig. 5 Speed Proportional Steering Control Module

INSTALLATION

- (1) Slid module onto mounting bracket.
- (2) Plug harness into module.

TRANSMISSION AND TRANSFER CASE

CONTENTS

	page		page
42/44RE AUTOMATIC TRANSMISSION	1	NV242 TRANSFER CASE	241
46RE AUTOMATIC TRANSMISSION	118	NV249 TRANSFER CASE	271

42/44RE AUTOMATIC TRANSMISSION

INDEX

	page		page
GENERAL INFORMATION			
42/44 RE TRANSMISSION	2	OVERDRIVE ELECTRICAL CONTROLS	10
CAUSES OF BURNT FLUID	4	PARK/NEUTRAL POSITION SWITCH	9
EFFECTS OF INCORRECT FLUID LEVEL	4	PRELIMINARY DIAGNOSIS	8
ELECTRONIC LOCK-UP		ROAD TESTING	10
TORQUE CONVERTER	4	STALL TEST ANALYSIS	14
FLUID CONTAMINATION	4	THROTTLE VALVE CABLE	10
GEARSHIFT MECHANISM	5	SERVICE PROCEDURES	
RECOMMENDED FLUID	4	ALUMINUM THREAD REPAIR	28
TRANSMISSION GEAR RATIOS	5	CONVERTER DRAINBACK	
TRANSMISSION IDENTIFICATION	4	CHECK VALVE SERVICE	27
DESCRIPTION AND OPERATION			
3-4 SHIFT SEQUENCE	7	FLUID AND FILTER REPLACEMENT	26
BRAKE TRANSMISSION SHIFT		FLUID LEVEL CHECK	26
INTERLOCK MECHANISM	8	FLUSHING COOLERS AND TUBES	28
CONVERTER CLUTCH ENGAGEMENT	8	OIL PUMP VOLUME CHECK	27
CONVERTER DRAINBACK VALVE	8	TRANSMISSION FILL PROCEDURE	27
ELECTRONIC GOVERNOR	5	REMOVAL AND INSTALLATION	
GOVERNOR PRESSURE CURVES	6	BRAKE TRANSMISSION SHIFT INTERLOCK ...	33
HYDRAULIC CONTROL SYSTEM	7	GEARSHIFT CABLE	33
OVERDRIVE OFF SWITCH	7	GOVERNOR SOLENOID AND	
QUICK FILL VALVE	8	PRESSURE SENSOR	34
SHIFT VALVE OPERATION	7	OUTPUT SHAFT FRONT BEARING	39
DIAGNOSIS AND TESTING			
AIR TESTING TRANSMISSION CLUTCH AND		OUTPUT SHAFT REAR BEARING	38
BAND OPERATION	14	OVERDRIVE HOUSING BUSHING	38
ANALYZING ROAD TEST	10	OVERDRIVE UNIT	37
AUTOMATIC TRANSMISSION DIAGNOSIS	8	PARK/NEUTRAL POSITION SWITCH	32
BRAKE TRANSMISSION SHIFT INTERLOCK ...	10	SPEEDOMETER ADAPTER	31
CONVERTER HOUSING		TORQUE CONVERTER	30
FLUID LEAK DIAGNOSIS	15	TRANSMISSION	28
CONVERTER STALL TEST	14	VALVE BODY	34
DIAGNOSIS TABLES AND CHARTS—		YOKE SEAL REPLACEMENT	31
RE TRANSMISSION	16	DISASSEMBLY AND ASSEMBLY	
GEARSHIFT CABLE	10	FRONT CLUTCH	68
HYDRAULIC PRESSURE TEST	11	FRONT SERVO PISTON	65
		OIL PUMP AND REACTION	
		SHAFT SUPPORT	65
		OVERDRIVE UNIT	76

OVERRUNNING CLUTCH CAM/ OVERDRIVE PISTON RETAINER	63	REAR CLUTCH	94
PLANETARY GEARTRAIN/OUTPUT SHAFT	71	REAR SERVO	93
REAR CLUTCH	70	TRANSMISSION	92
REAR SERVO PISTON	65	VALVE BODY	91
TRANSMISSION	53	ADJUSTMENTS	
VALVE BODY	39	BAND ADJUSTMENTS	98
CLEANING AND INSPECTION		BRAKE TRANSMISSION SHIFT INTERLOCK ...	95
ACCUMULATOR	92	GEARSHIFT CABLE	97
FRONT CLUTCH	93	TRANSMISSION THROTTLE VALVE CABLE ADJUSTMENT	96
FRONT SERVO	93	VALVE BODY	98
OIL PUMP AND REACTION SHAFT SUPPORT	93	SCHEMATICS AND DIAGRAMS	
OVERDRIVE UNIT	95	HYDRAULIC SCHEMATICS	99
OVERRUNNING CLUTCH/LOW-REVERSE DRUM/OVERDRIVE PISTON RETAINER	92	SPECIFICATIONS	
PLANETARY GEARTRAIN	94	TRANSMISSION	112
		SPECIAL TOOLS	
		RE TRANSMISSIONS	112

GENERAL INFORMATION

42/44 RE TRANSMISSION

The 42/44RE is a four speed fully automatic transmission (Fig. 1) with an electronic governor. First through third gear ranges are provided by the clutches, bands, overrunning clutch, and planetary gear sets in the transmission. Fourth gear range is provided by the overdrive unit that contains an overdrive clutch, direct clutch, planetary gear set, and overrunning clutch. The overdrive clutch is applied in fourth gear only. The direct clutch is applied in all ranges except fourth gear. The torque converter

clutch is controlled by the Powertrain Control Module (PCM). The torque converter clutch is hydraulically applied and is released when fluid is vented from the hydraulic circuit by the torque converter control (TCC) solenoid on the valve body. The torque converter clutch engages in fourth gear, and in third gear when the O/D switch is OFF. Engagement occurs when the vehicle is moving at a steady speed after the vehicle has warmed up. The torque converter clutch disengages when the accelerator is applied. The 42/44 RE transmission is cooled by an integral fluid cooler inside the radiator.

GENERAL INFORMATION (Continued)

J9321-407

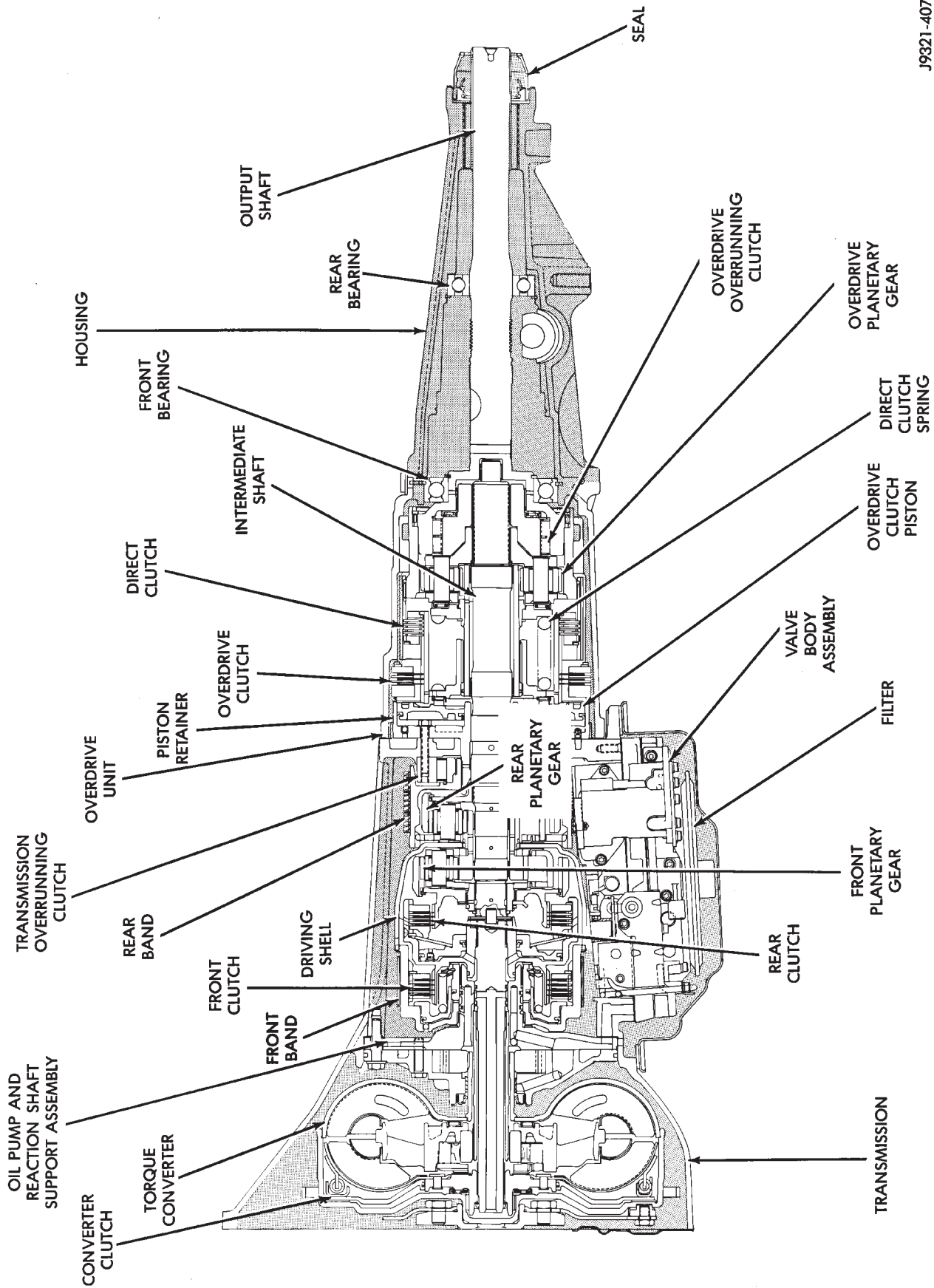
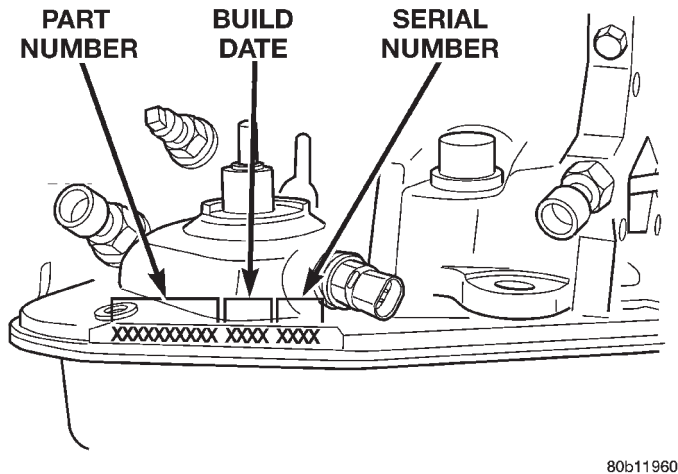


Fig. 1 42/44 RE Transmission

GENERAL INFORMATION (Continued)

TRANSMISSION IDENTIFICATION

Transmission identification numbers are stamped on the left side of the case just above the oil pan gasket surface (Fig. 2). Refer to this information when ordering replacement parts.



80b11960

Fig. 2 Transmission Part And Serial Number Location

RECOMMENDED FLUID

Mopar® ATF Plus 3, Type 7176 automatic transmission fluid is the recommended fluid for Chrysler automatic transmissions.

Dexron II fluid IS NOT recommended. Clutch chatter can result from the use of improper fluid.

EFFECTS OF INCORRECT FLUID LEVEL

A low fluid level allows the pump to take in air along with the fluid. Air in the fluid will cause fluid pressures to be low and develop slower than normal. If the transmission is overfilled, the gears churn the fluid into foam. This aerates the fluid and causing the same conditions occurring with a low level. In either case, air bubbles cause fluid overheating, oxidation and varnish buildup which interferes with valve, clutch and servo operation. Foaming also causes fluid expansion which can result in fluid overflow from the transmission vent or fill tube. Fluid overflow can easily be mistaken for a leak if inspection is not careful.

CAUSES OF BURNT FLUID

Burnt, discolored fluid is a result of overheating which has two primary causes.

(1) A result of restricted fluid flow through the main and/or auxiliary cooler. This condition is usually the result of a faulty or improperly installed drainback valve, a damaged main cooler, or severe restrictions in the coolers and lines caused by debris or kinked lines.

(2) Heavy duty operation with a vehicle not properly equipped for this type of operation. Trailer towing or similar high load operation will overheat the transmission fluid if the vehicle is improperly equipped. Such vehicles should have an auxiliary transmission fluid cooler, a heavy duty cooling system, and the engine/axle ratio combination needed to handle heavy loads.

FLUID CONTAMINATION

Transmission fluid contamination is generally a result of:

- adding incorrect fluid
- failure to clean dipstick and fill tube when checking level
- engine coolant entering the fluid
- internal failure that generates debris
- overheat that generates sludge (fluid breakdown)
- failure to reverse flush cooler and lines after repair
- failure to replace contaminated converter after repair

The use of non recommended fluids can result in transmission failure. The usual results are erratic shifts, slippage, abnormal wear and eventual failure due to fluid breakdown and sludge formation. Avoid this condition by using recommended fluids only.

The dipstick cap and fill tube should be wiped clean before checking fluid level. Dirt, grease and other foreign material on the cap and tube could fall into the tube if not removed beforehand. Take the time to wipe the cap and tube clean before withdrawing the dipstick.

Engine coolant in the transmission fluid is generally caused by a cooler malfunction. The only remedy is to replace the radiator as the cooler in the radiator is not a serviceable part. If coolant has circulated through the transmission for some time, an overhaul may also be necessary; especially if shift problems had developed.

The transmission cooler and lines should be reverse flushed whenever a malfunction generates sludge and/or debris. The torque converter should also be replaced at the same time.

Failure to flush the cooler and lines will result in recontamination. Flushing applies to auxiliary coolers as well. The torque converter should also be replaced whenever a failure generates sludge and debris. This is necessary because normal converter flushing procedures will not remove all contaminants.

ELECTRONIC LOCK-UP TORQUE CONVERTER

The torque converter is a hydraulic device that couples the engine crankshaft to the transmission.

GENERAL INFORMATION (Continued)

The torque converter consists of an outer shell with an internal turbine, a stator, an overrunning clutch, an impeller, and an electronically applied converter clutch. Torque multiplication is created when the stator directs the hydraulic flow from the turbine to rotate the impeller in the direction the engine crankshaft is turning. The turbine transfers power to the planetary gear sets in the transmission. The transfer of power into the impeller assists torque multiplication. At low vehicle-speed, the overrunning clutch holds the stator stationary (during torque multiplication) and allows the stator to freewheel at high vehicle speed. The converter clutch engagement reduces engine speed. Clutch engagement also provides reduced transmission fluid temperatures. The torque converter hub drives the transmission oil (fluid) pump.

The torque converter is a sealed, welded unit that is not repairable and is serviced as an assembly.

CAUTION: The torque converter must be replaced if a transmission failure results in large amounts of metal or fiber contamination in the fluid.

TRANSMISSION GEAR RATIOS

Gear ratios are:

- 1st 2.74:1
- 2nd 1.54:1
- 3rd 1.00:1
- 4th 0.69:1
- Rev. 2.21

GEARSHIFT MECHANISM

The shift mechanism is cable operated and provides six shift positions. The shift positions are:

- Park (P)
- Reverse (R)
- Neutral (N)
- Drive (D)
- Manual Second (2)
- Manual Low (1)

Manual low (1) range provides first gear only. Overrun braking is also provided in this range. Manual second (2) range provides first and second gear only. Drive range provides first, second, third, and overdrive fourth gear ranges. The shift into overdrive fourth gear range occurs only after the transmission has completed the shift into (D) third gear range. No further movement of the shift mechanism is required to complete the 3-4 shift.

DESCRIPTION AND OPERATION

ELECTRONIC GOVERNOR

Governor pressure is controlled electronically. Components used for governor pressure control include:

- Governor body
- Valve body transfer plate
- Governor pressure solenoid valve
- Governor pressure sensor
- Fluid temperature thermistor
- Throttle position sensor (TPS)
- Transmission speed sensor
- Powertrain control module (PCM)

GOVERNOR PRESSURE SOLENOID VALVE

The solenoid valve is a duty-cycle solenoid which regulates the governor pressure needed for upshifts and downshifts. It is an electro-hydraulic device located in the governor body on the valve body transfer plate (Fig. 3).

The inlet side of the solenoid valve is exposed to normal transmission line pressure. The outlet side of the valve leads to the valve body governor circuit.

The solenoid valve regulates line pressure to produce governor pressure. The average current supplied to the solenoid controls governor pressure. One amp current produces zero kPa/psi governor pressure. Zero amps sets the maximum governor pressure.

The powertrain control module (PCM) turns on the trans control relay which supplies electrical power to the solenoid valve. Operating voltage is 12 volts (DC). The PCM controls the ground side of the solenoid using the governor pressure solenoid control circuit.

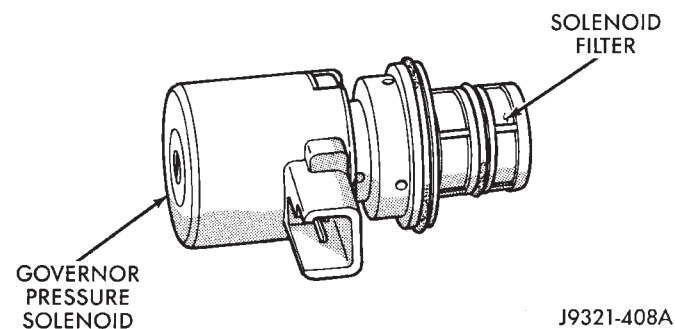
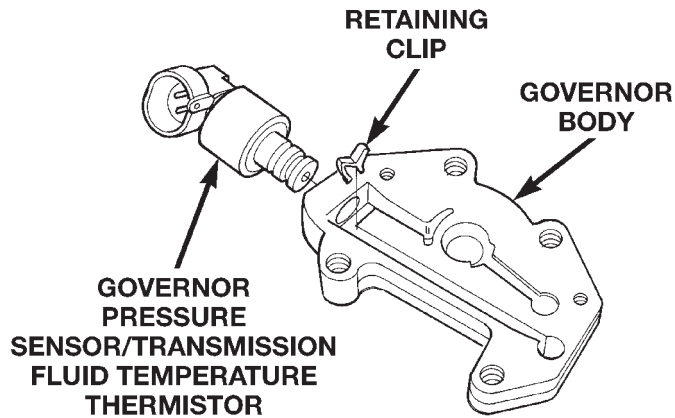


Fig. 3 Governor Pressure Solenoid Valve

GOVERNOR PRESSURE SENSOR

The governor pressure sensor measures output pressure of the governor pressure solenoid valve (Fig. 4).

The sensor output signal provides the necessary feedback to the PCM. This feedback is needed to adequately control governor pressure.

DESCRIPTION AND OPERATION (Continued)

80a0c4fa

Fig. 4 Governor Pressure Sensor**GOVERNOR BODY AND TRANSFER PLATE**

The transfer plate is designed to supply transmission line pressure to the governor pressure solenoid valve and to return governor pressure.

The governor pressure solenoid valve is mounted in the governor body. The body is bolted to the lower side of the transfer plate (Fig. 4). The transfer plate channels line pressure to the solenoid valve through the governor body. It also channels governor pressure from the solenoid valve to the governor circuit. It is the solenoid valve that develops the necessary governor pressure.

TRANSMISSION FLUID TEMPERATURE THERMISTOR

Transmission fluid temperature readings are supplied to the transmission control module by the thermistor. The temperature readings are used to control engagement of the fourth gear overdrive clutch, the converter clutch, and governor pressure. Normal resistance value for the thermistor at room temperature is approximately 1000 ohms.

The PCM prevents engagement of the converter clutch and overdrive clutch, when fluid temperature is below approximately 10°C (50°F).

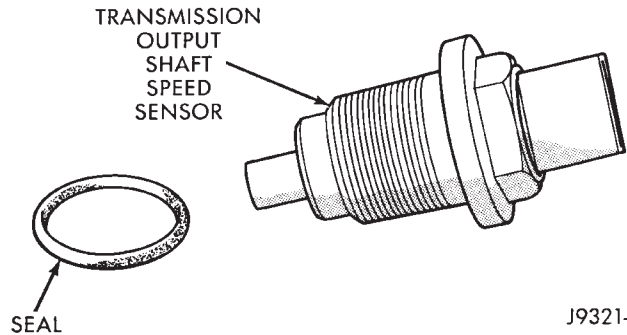
If fluid temperature exceeds 126°C (260°F), the PCM causes a 4-3 downshift and engage the converter clutch. Engagement is according to the third gear converter clutch engagement schedule.

The overdrive OFF lamp in the instrument panel illuminates when the shift back to third occurs. The transmission will not allow fourth gear operation until fluid temperature decreases to approximately 110°C (230°F).

The thermistor is part of the governor pressure sensor assembly and is immersed in transmission fluid at all times.

TRANSMISSION SPEED SENSOR

The speed sensor (Fig. 5) is located in the overdrive gear case. The sensor is positioned over the park gear and monitors transmission output shaft rotating speed. Speed sensor signals are triggered by the park gear lugs as they rotate past the sensor pickup face. Input signals from the sensor are sent to the transmission control module for processing. The vehicle speed sensor also serves as a backup for the transmission speed sensor. Signals from this sensor are shared with the powertrain control module.



J9321-411

Fig. 5 Transmission Output Speed Sensor**THROTTLE POSITION SENSOR (TPS)**

The TPS provides throttle position input signals to the PCM. This input signal is used to determine overdrive and converter clutch shift schedule and to select the proper governor curve.

POWERTRAIN CONTROL MODULE (PCM)

The PCM controls operation of the converter clutch, overdrive clutch, and governor pressure solenoid.

The control module determines transmission shift points based on input signals from the transmission thermistor, transmission output shaft speed sensor, crankshaft position sensor, vehicle speed sensor, throttle position sensor, and battery temperature sensor.

GOVERNOR PRESSURE CURVES

There are four governor pressure curves programmed into the transmission control module. The different curves allow the control module to adjust governor pressure for varying conditions. One curve is used for operation when fluid temperature is at, or below, 1°C (30°F). A second curve is used when fluid temperature is at, or above, 10°C (50°F) during normal city or highway driving. A third curve is used during wide-open throttle operation. The fourth curve is used when driving with the transfer case in low range.

DESCRIPTION AND OPERATION (Continued)

SHIFT VALVE OPERATION

The shift valves are moved by a combination of throttle and governor pressure. The governor pressure is generated by electrical components.

The conditions under which a shift to fourth will not occur are:

- Overdrive switch is Off
- Transmission fluid temperature is below 10° C (50° F) or above 121° C (250° F)
- Shift to third not yet completed
- Vehicle speed too low for 3-4 shift to occur
- Battery temperature below -5° F.

HYDRAULIC CONTROL SYSTEM

The hydraulic control system provides fully automatic operation. The system performs five basic functions which are: pressure supply, pressure regulation, flow control, clutch/band application, and lubrication.

PRESSURE REGULATION

The pressure regulator valve maintains line pressure. The amount of pressure developed is controlled by throttle pressure which is dependent on the degree of throttle opening. The regulator valve is located in the valve body.

The throttle valve determines line pressure and shift speed. Governor pressure increases in proportion to vehicle speed. The throttle valve controls upshift and downshift speeds by regulating pressure according to throttle position.

Shift Valve Flow Control

The manual valve is operated by the gearshift linkage and provides the operating range selected by the driver.

The 1-2 shift valve provides 1-2 or 2-1 shifts and the 2-3 shift valve provides 2-3 or 3-2 shifts.

The kickdown valve provides forced 3-2 or 3-1 downshifts depending on vehicle speed. Downshifts occur when the throttle is opened beyond downshift detent position. Detent is reached just before wide open throttle position.

The 2-3 valve throttle pressure plug provides 3-2 downshifts at varying throttle openings depending on vehicle speed.

The 1-2 shift control valve transmits 1-2 shift pressure to the accumulator piston. This controls kickdown band capacity on 1-2 upshifts and 3-2 downshifts.

The 3-4 shift, quick fill, and timing valves plus the 3-4 accumulator, are only actuated when the overdrive solenoid is energized. The solenoid contains a check ball that controls a vent port to the 3-4 valves. The check ball either diverts line pressure away from or directly to the 3-4 valves.

The limit valve determines maximum speed at which a 3-2 part throttle kickdown can be made. On

transmissions without a limit valve, maximum speed for a 3-2 kickdown is at detent position.

The 2-3 shuttle valve has two functions. The first is fast front band release and smooth engagement during lift-foot 2-3 upshifts. The second is to regulate front clutch and band application during 3-2 downshifts.

The 3-4 timing valve is moved by line pressure coming through the 3-4 shift valve. The timing valve holds the 2-3 shift valve in an upshift position. The purpose is to prevent the 2-3 valve from up or downshifting before the 3-4 valve.

The 3-4 accumulator is mounted on the overdrive housing and performs the same function as the 2-3 accumulator; it is used to smooth engagement during a 3-4 shift.

The switch valve directs fluid apply pressure to the converter clutch in one position and releases it in the opposite position. It also directs oil to the cooling and lube circuits. The switch valve regulates oil pressure to the torque converter by limiting maximum oil pressure to 130 psi.

OVERDRIVE OFF SWITCH

The overdrive OFF (control) switch is located in the instrument panel. The switch is a momentary contact device that signals the PCM to toggle current status of the overdrive function. At key-on, overdrive operation is allowed. Pressing the switch once causes the overdrive OFF mode to be entered and the overdrive OFF switch lamp to be illuminated. Pressing the switch a second time causes normal overdrive operation to be restored and the overdrive lamp to be turned off. The overdrive OFF mode defaults to ON after the ignition switch is cycled OFF and ON. The normal position for the control switch is the ON position. The switch must be in this position to energize the solenoid and allow a 3-4 upshift. The control switch indicator light illuminates only when the overdrive switch is turned to the OFF position, or when illuminated by the transmission control module.

3-4 SHIFT SEQUENCE

The overdrive clutch is applied in fourth gear only. The direct clutch is applied in all ranges except fourth gear. Fourth gear overdrive range is electronically controlled and hydraulically activated. Various sensor inputs are supplied to the powertrain control module to operate the overdrive solenoid on the valve body. The solenoid contains a check ball that opens and closes a vent port in the 3-4 shift valve feed passage. The overdrive solenoid (and check ball) are not energized in first, second, third, or reverse gear. The vent port remains open, diverting line pressure from the 2-3 shift valve away from the 3-4 shift valve. The overdrive control switch must be in the ON position

DESCRIPTION AND OPERATION (Continued)

to transmit overdrive status to the PCM. A 3-4 upshift occurs only when the overdrive solenoid is energized by the PCM. The PCM energizes the overdrive solenoid during the 3-4 upshift. This causes the solenoid check ball to close the vent port allowing line pressure from the 2-3 shift valve to act directly on the 3-4 upshift valve. Line pressure on the 3-4 shift valve overcomes valve spring pressure moving the valve to the upshift position. This action exposes the feed passages to the 3-4 timing valve, 3-4 quick fill valve, 3-4 accumulator, and ultimately to the overdrive piston. Line pressure through the timing valve moves the overdrive piston into contact with the overdrive clutch. The direct clutch is disengaged before the overdrive clutch is engaged. The boost valve provides increased fluid apply pressure to the overdrive clutch during 3-4 upshifts, and when accelerating in fourth gear. The 3-4 accumulator cushions overdrive clutch engagement to smooth 3-4 upshifts. The accumulator is charged at the same time as apply pressure acts against the overdrive piston.

CONVERTER CLUTCH ENGAGEMENT

Converter clutch engagement in third or fourth gear range is controlled by sensor inputs to the powertrain control module. Inputs that determine clutch engagement are: coolant temperature, engine rpm, vehicle speed, throttle position, and manifold vacuum. The torque converter clutch is engaged by the clutch solenoid on the valve body. The clutch can be engaged in third and fourth gear ranges depending on overdrive control switch position. If the overdrive control switch is in the normal ON position, the clutch will engage after the shift to fourth gear, and above approximately 72 km/h (45 mph). If the control switch is in the OFF position, the clutch will engage after the shift to third gear, at approximately 56 km/h (35 mph) at light throttle.

QUICK FILL VALVE

The 3-4 quick fill valve provides faster engagement of the overdrive clutch during 3-4 upshifts. The valve temporarily bypasses the clutch piston feed orifice at the start of a 3-4 upshift. This exposes a larger passage into the piston retainer resulting in a much faster clutch fill and apply sequence. The quick fill valve does not bypass the regular clutch feed orifice throughout the 3-4 upshift. Instead, once a predetermined pressure develops within the clutch, the valve closes the bypass. Clutch fill is then completed through the regular feed orifice.

CONVERTER DRAINBACK VALVE

The drainback valve is located in the transmission cooler outlet (pressure) line. The valve prevents fluid from draining from the converter into the cooler and

lines when the vehicle is shut down for lengthy periods. Production valves have a hose nipple at one end, while the opposite end is threaded for a flare fitting. All valves have an arrow (or similar mark) to indicate direction of flow through the valve.

BRAKE TRANSMISSION SHIFT INTERLOCK MECHANISM

The Brake Transmission Shifter/Ignition Interlock (BTSI), is a cable and solenoid operated system. It interconnects the automatic transmission floor mounted shifter to the steering column ignition switch (Fig. 6). The system locks the shifter into the PARK position. The Interlock system is engaged whenever the ignition switch is in the LOCK or ACCESSORY position. An additional electrically activated feature will prevent shifting out of the PARK position unless the brake pedal is depressed at least one-half an inch. A magnetic holding device in line with the park lock cable is energized when the ignition is in the RUN position. When the key is in the RUN position and the brake pedal is depressed, the shifter is unlocked and will move into any position. The interlock system also prevents the ignition switch from being turned to the LOCK or ACCESSORY position (Fig. 7), unless the shifter is fully locked into the PARK position.

DIAGNOSIS AND TESTING

AUTOMATIC TRANSMISSION DIAGNOSIS

Automatic transmission problems can be a result of poor engine performance, incorrect fluid level, incorrect linkage or cable adjustment, band or hydraulic control pressure adjustments, hydraulic system malfunctions or electrical/mechanical component malfunctions. Begin diagnosis by checking the easily accessible items such as: fluid level and condition, linkage adjustments and electrical connections. A road test will determine if further diagnosis is necessary.

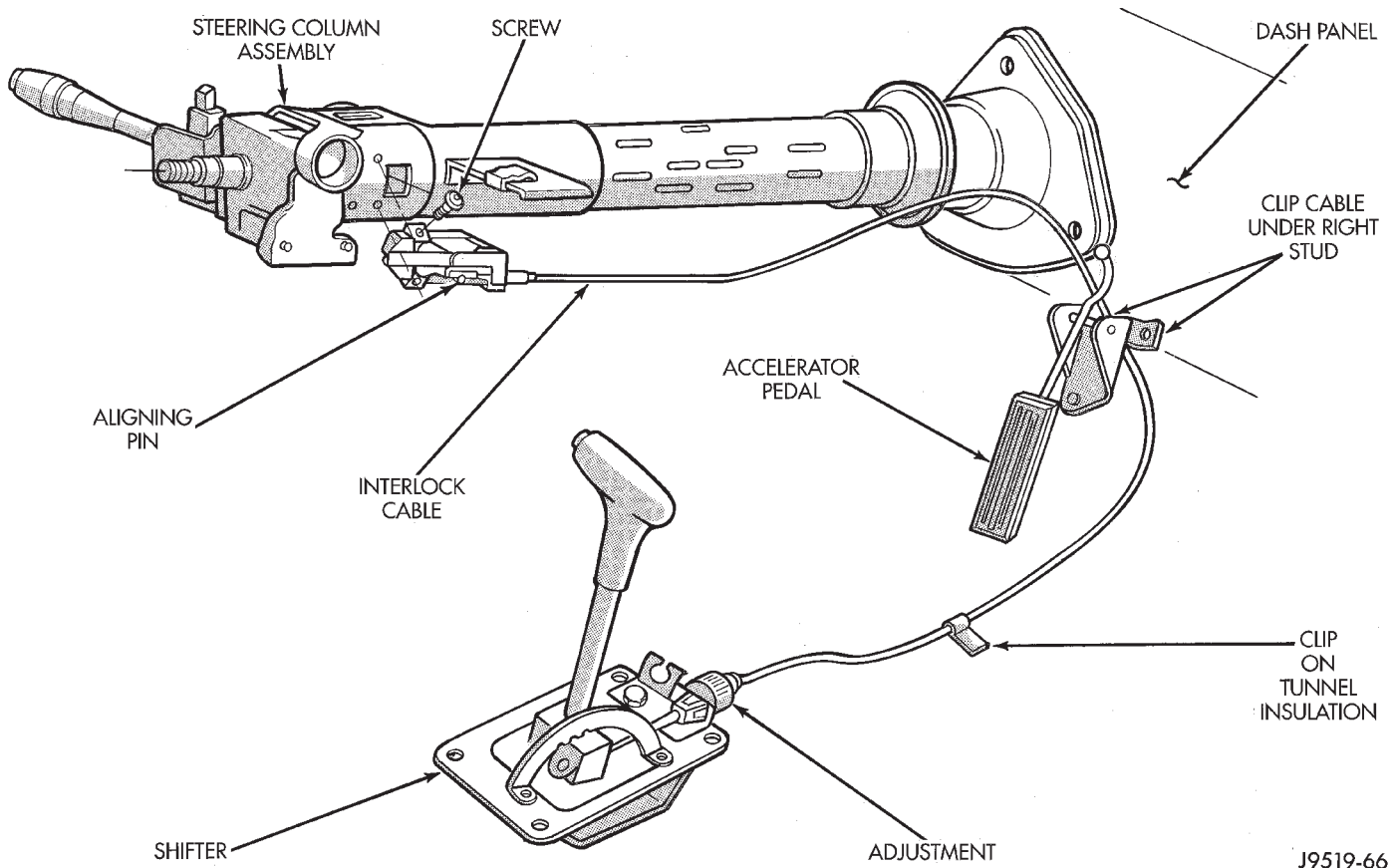
PRELIMINARY DIAGNOSIS

Two basic procedures are required. One procedure for vehicles that are drivable and an alternate procedure for disabled vehicles (will not back up or move forward).

VEHICLE IS DRIVEABLE

- (1) Check for transmission fault codes using DRB scan tool.
- (2) Check fluid level and condition.
- (3) Adjust throttle and gearshift linkage if complaint was based on delayed, erratic, or harsh shifts.
- (4) Road test and note how transmission upshifts, downshifts, and engages.

DIAGNOSIS AND TESTING (Continued)



J9519-66

Fig. 6 Ignition Interlock Cable Routing

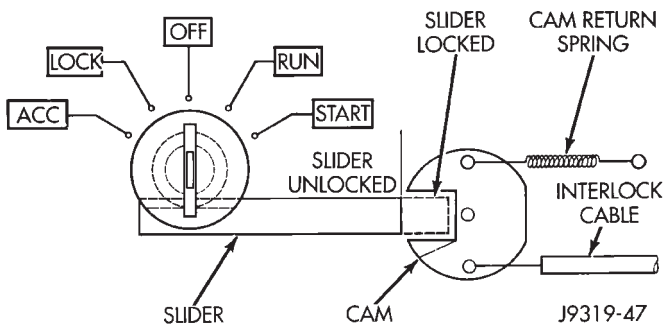


Fig. 7 Ignition Key Cylinder Actuation

(5) Perform stall test if complaint is based on sluggish acceleration. Or, if abnormal throttle opening is needed to maintain normal speeds with a properly tuned engine.

(6) Perform hydraulic pressure test if shift problems were noted during road test.

(7) Perform air-pressure test to check clutch-band operation.

VEHICLE IS DISABLED

- (1) Check fluid level and condition.
- (2) Check for broken or disconnected gearshift or throttle linkage.

(3) Check for cracked, leaking cooler lines, or loose or missing pressure-port plugs.

(4) Raise and support vehicle on safety stands, start engine, shift transmission into gear, and note following:

(a) If propeller shaft turns but wheels do not, problem is with differential or axle shafts.

(b) If propeller shaft does not turn and transmission is noisy, stop engine. Remove oil pan, and check for debris. If pan is clear, remove transmission and check for damaged drive plate, converter, oil pump, or input shaft.

(c) If propeller shaft does not turn and transmission is not noisy, perform hydraulic-pressure test to determine if problem is hydraulic or mechanical.

PARK/NEUTRAL POSITION SWITCH

The center terminal of the park/neutral position switch is the starter-circuit terminal. It provides the ground for the starter solenoid circuit through the selector lever in PARK and NEUTRAL positions only. The outer terminals on the switch are for the backup lamp circuit.

SWITCH TEST

To test the switch, remove the wiring connector. Test for continuity between the center terminal and

DIAGNOSIS AND TESTING (Continued)

the transmission case. Continuity should exist only when the transmission is in PARK or NEUTRAL.

Shift the transmission into REVERSE and test continuity at the switch outer terminals. Continuity should exist only when the transmission is in REVERSE. Continuity should not exist between the outer terminals and the case.

Check gearshift linkage adjustment before replacing a switch that tests faulty.

OVERDRIVE ELECTRICAL CONTROLS

The overdrive off switch, valve body solenoid, case connectors and related wiring can all be tested with a 12 volt test lamp or a volt/ohmmeter. Check continuity of each component when diagnosis indicates this is necessary. Refer to Group 8W, Wiring Diagrams, for component locations and circuit information.

Switch and solenoid continuity should be checked whenever the transmission fails to shift into fourth gear range.

BRAKE TRANSMISSION SHIFT INTERLOCK

(1) Verify that the key can only be removed in the PARK position

(2) When the shift lever is in PARK And the shift handle pushbutton is in the "OUT" position, the ignition key cylinder should rotate freely from OFF to LOCK. When the shifter is in any other gear or neutral position, the ignition key cylinder should not rotate to the LOCK position.

(3) Shifting out of PARK should be possible when the ignition key cylinder is in the OFF position.

(4) Shifting out of PARK should not be possible while applying 25 lb. maximum handle pushbutton force and ignition key cylinder is in the RUN or START positions unless the foot brake pedal is depressed approximately 1/2 inch (12mm).

(5) Shifting out of PARK should not be possible when the ignition key cylinder is in the ACCESSORY or LOCK positions.

(6) Shifting between any gears, NEUTRAL or into PARK may be done without depressing foot brake pedal with ignition switch in RUN or START positions and vehicle stationary or in motion.

GEARSHIFT CABLE

(1) The floor shifter lever and gate positions should be in alignment with all transmission PARK, NEUTRAL, and gear detent positions.

(2) Engine starts must be possible with floor shift lever in PARK or NEUTRAL gate positions only. Engine starts must not be possible in any other gear position.

(3) With floor shift lever handle push-button not depressed and lever in:

(a) PARK position—Apply forward force on center of handle and remove pressure. Engine starts must be possible.

(b) PARK position—Apply rearward force on center of handle and remove pressure. Engine starts must be possible.

(c) NEUTRAL position—Normal position. Engine starts must be possible.

(d) NEUTRAL position—Engine running and brakes applied, apply forward force on center of shift handle. Transmission shall not be able to shift from neutral to reverse.

THROTTLE VALVE CABLE

Transmission throttle valve cable adjustment is extremely important to proper operation. This adjustment positions the throttle valve, which controls shift speed, quality, and part-throttle downshift sensitivity.

If cable setting is too loose, early shifts and slippage between shifts may occur. If the setting is too tight, shifts may be delayed and part throttle downshifts may be very sensitive. Refer to the Adjustments section for the proper adjustment procedure.

ROAD TESTING

Before road testing, be sure the fluid level and control cable adjustments have been checked and adjusted if necessary. Verify that diagnostic trouble codes have been resolved.

Observe engine performance during the road test. A poorly tuned engine will not allow accurate analysis of transmission operation.

Operate the transmission in all gear ranges. Check for shift variations and engine flare which indicates slippage. Note if shifts are harsh, spongy, delayed, early, or if part throttle downshifts are sensitive.

Slippage indicated by engine flare, usually means clutch, band or overrunning clutch problems. If the condition is advanced, an overhaul will be necessary to restore normal operation.

A slipping clutch or band can often be determined by comparing which internal units are applied in the various gear ranges. The Clutch and Band Application chart provides a basis for analyzing road test results.

ANALYZING ROAD TEST

Refer to the Clutch and Band Application chart and note which elements are in use in the various gear ranges.

Note that the rear clutch is applied in all forward ranges (D, 2, 1). The transmission overrunning clutch is applied in first gear (D, 2 and 1 ranges) only. The rear band is applied in 1 and R range only.

Note that the overdrive clutch is applied only in fourth gear and the overdrive direct clutch and over-

DIAGNOSIS AND TESTING (Continued)

SHIFT LEVER POSITION	TRANSMISSION CLUTCHES AND BANDS					OVERDRIVE CLUTCHES		
	FRONT CLUTCH	FRONT BAND	REAR CLUTCH	REAR BAND	OVERRUN. CLUTCH	OVERDRIVE CLUTCH	DIRECT CLUTCH	OVERRUN. CLUTCH
Reverse	X			X			X	
Drive Range								
First			X		X		X	X
Second		X	X				X	X
Third	X		X				X	X
Fourth	X		X			X		
2-Range (Manual Second)		X	X		X		X	X
1-Range (Manual Low)			X	X	X		X	X

J9421-218

Clutch And Band Application Chart

running clutch are applied in all ranges except fourth gear.

For example: If slippage occurs in first gear in D and 2 range but not in 1 range, the transmission overrunning clutch is faulty. Similarly, if slippage occurs in any two forward gears, the rear clutch is slipping.

Applying the same method of analysis, note that the front and rear clutches are applied simultaneously only in D range third and fourth gear. If the transmission slips in third gear, either the front clutch or the rear clutch is slipping.

If the transmission slips in fourth gear but not in third gear, the overdrive clutch is slipping. By selecting another gear which does not use these clutches, the slipping unit can be determined. For example, if the transmission also slips in Reverse, the front clutch is slipping. If the transmission does not slip in Reverse, the rear clutch is slipping.

If slippage occurs during the 3-4 shift or only in fourth gear, the overdrive clutch is slipping. Similarly, if the direct clutch were to fail, the transmission would lose both reverse gear and overdrive braking in 2 position (manual second gear).

If the transmission will not shift to fourth gear, the control switch, overdrive solenoid or related wiring may also be the problem cause.

This process of elimination can be used to identify a slipping unit and check operation. Proper use of the Clutch and Band Application Chart is the key.

Although road test analysis will help determine the slipping unit, the actual cause of a malfunction usu-

ally cannot be determined until hydraulic and air pressure tests are performed. Practically any condition can be caused by leaking hydraulic circuits or sticking valves.

Unless a malfunction is obvious, such as no drive in D range first gear, do not disassemble the transmission. Perform the hydraulic and air pressure tests to help determine the probable cause.

HYDRAULIC PRESSURE TEST

Hydraulic test pressures range from a low of one psi (6.895 kPa) governor pressure, to 300 psi (2068 kPa) at the rear servo pressure port in reverse.

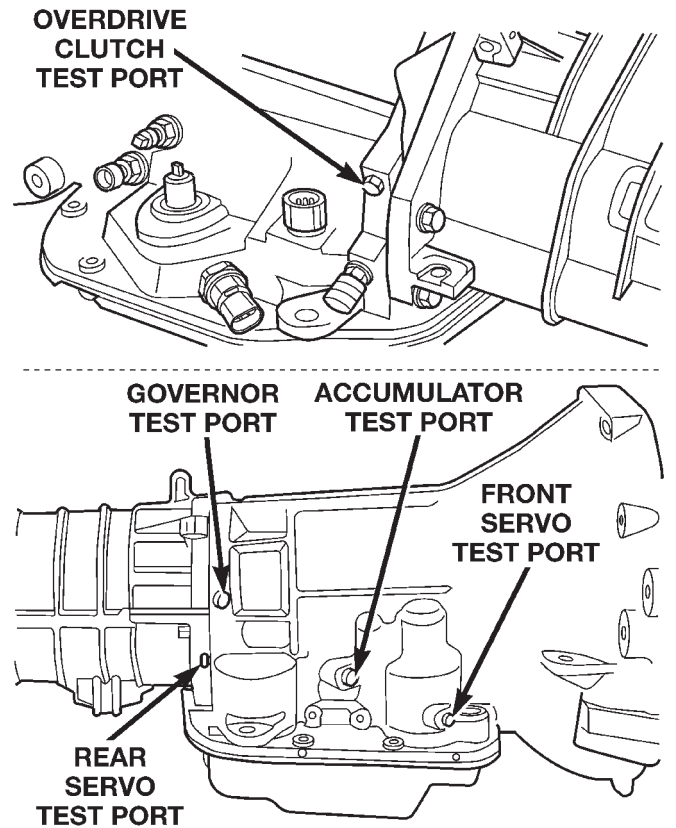
An accurate tachometer and pressure test gauges are required. Test Gauge C-3292 has a 100 psi range and is used at the accumulator, governor, and front servo ports. Test Gauge C-3293-SP has a 300 psi range and is used at the rear servo and overdrive ports where pressures exceed 100 psi.

Pressure Test Port Locations

Test ports are located at both sides of the transmission case (Fig. 8).

Line pressure is checked at the accumulator port on the right side of the case. The front servo pressure port is at the right side of the case just behind the filler tube opening.

The rear servo and governor pressure ports are at the right rear of the transmission case. The overdrive clutch pressure port is at the left rear of the case.

DIAGNOSIS AND TESTING (Continued)**Fig. 8 Pressure Test Port Locations****Test One - Transmission In Manual Low**

NOTE: This test checks pump output, pressure regulation, and condition of the rear clutch and servo circuit. Both test gauges are required for this test.

- (1) Connect tachometer to engine. Position tachometer so it can be observed from driver seat if helper will be operating engine. Raise vehicle on hoist that will allow rear wheels to rotate freely.
- (2) Connect 100 psi Gauge C-3292 to accumulator port. Then connect 300 psi Gauge C-3293-SP to rear servo port.
- (3) Disconnect throttle and gearshift cables from levers on transmission valve body manual shaft.
- (4) Have helper start and run engine at 1000 rpm.
- (5) Move transmission shift lever fully forward into 1 range.
- (6) Gradually move transmission throttle lever from full forward to full rearward position and note pressures on both gauges:
 - Line pressure at accumulator port should be 54-60 psi (372-414 kPa) with throttle lever forward and gradually increase to 90-96 psi (621-662 kPa) as throttle lever is moved rearward.
 - Rear servo pressure should be same as line pressure within 3 psi (20.68 kPa).

Test Two—Transmission In 2 Range

NOTE: This test checks pump output, line pressure and pressure regulation. Use 100 psi Test Gauge C-3292 for this test.

- (1) Leave vehicle in place on hoist and leave Test Gauge C-3292 connected to accumulator port.
- (2) Have helper start and run engine at 1000 rpm.
- (3) Move transmission shift lever one detent rearward from full forward position. This is 2 range.
- (4) Move transmission throttle lever from full forward to full rearward position and read pressure on gauge.
- (5) Line pressure should be 54-60 psi (372-414 kPa) with throttle lever forward and gradually increase to 90-96 psi (621-662 kPa) as lever is moved rearward.

Test Three—Transmission In D Range Third Gear

NOTE: This test checks pressure regulation and condition of the clutch circuits. Both test gauges are required for this test.

- (1) Turn OD switch off.
- (2) Leave vehicle on hoist and leave Gauge C-3292 in place at accumulator port.
- (3) Move Gauge C-3293-SP over to front servo port for this test.
- (4) Have helper start and run engine at 1600 rpm for this test.
- (5) Move transmission shift lever two detents rearward from full forward position. This is D range.
- (6) Read pressures on both gauges as transmission throttle lever is gradually moved from full forward to full rearward position:
 - Line pressure at accumulator in D range third gear, should be 54-60 psi (372-414 kPa) with throttle lever forward and increase as lever is moved rearward.
 - Front servo pressure in D range third gear, should be within 3 psi (21 kPa) of line pressure up to kickdown point.

Test Four—Transmission In Reverse

NOTE: This test checks pump output, pressure regulation and the front clutch and rear servo circuits. Use 300 psi Test Gauge C-3293-SP for this test.

- (1) Leave vehicle on hoist and leave gauge C3292 in place at accumulator port.
- (2) Move 300 psi Gauge C-3293-SP back to rear servo port.
- (3) Have helper start and run engine at 1600 rpm for test.

DIAGNOSIS AND TESTING (Continued)

(4) Move transmission shift lever four detents rearward from full forward position. This is Reverse range.

(5) Move transmission throttle lever fully forward then fully rearward and note reading at Gauge C-3293-SP.

(6) Pressure should be 145 - 175 psi (1000-1207 kPa) with throttle lever forward and increase to 230 - 280 psi (1586-1931 kPa) as lever is gradually moved rearward.

Test Five—Governor Pressure

NOTE: This test checks governor operation by measuring governor pressure response to changes in vehicle speed. It is usually not necessary to check governor operation unless shift speeds are incorrect or if the transmission will not downshift. The test should be performed on the road or on a hoist that will allow the rear wheels to rotate freely.

(1) Move 100 psi Test Gauge C-3292 to governor pressure port.

(2) Move transmission shift lever two detents rearward from full forward position. This is D range.

(3) Have helper start and run engine at curb idle speed. Then firmly apply service brakes so wheels will not rotate.

(4) Note governor pressure:

- Governor pressure should be no more than 20.6 kPa (3 psi) at curb idle speed and wheels not rotating.

- If pressure exceeds 20.6 kPa (3 psi), a fault exists in governor pressure control system.

(5) Release brakes, slowly increase engine speed, and observe speedometer and pressure test gauge (do not exceed 30 mph on speedometer). Governor pressure should increase in proportion to vehicle speed. Or approximately 6.89 kPa (1 psi) for every 1 mph.

(6) Governor pressure rise should be smooth and drop back to no more than 20.6 kPa (3 psi), after engine returns to curb idle and brakes are applied to prevent wheels from rotating.

(7) Compare results of pressure test with analysis chart.

Test Six—Transmission In Overdrive Fourth Gear

NOTE: This test checks line pressure at the overdrive clutch in fourth gear range. Use 300 psi Test Gauge C-3292 for this test. The test should be performed on the road or on a chassis dyno.

(1) Remove tachometer; it is not needed for this test.

(2) Move 300 psi Gauge to overdrive clutch pressure test port. Then remove other gauge and reinstall test port plug.

(3) Lower vehicle.

(4) Turn OD switch on.

(5) Secure test gauge so it can be viewed from drivers seat.

(6) Start engine and shift into D range.

(7) Increase vehicle speed gradually until 3-4 shift occurs and note gauge pressure.

(8) Pressure should be 469-496 kPa (68-72 psi) with closed throttle and increase to 620-827 kPa (90-120 psi) at 1/2 to 3/4 throttle. Note that pressure can increase to around 896 kPa (130 psi) at full throttle.

(9) Return to shop or move vehicle off chassis dyno.

PRESSURE TEST ANALYSIS CHART

TEST CONDITION	INDICATION
Line pressure OK during any one test	Pump and regulator valve OK
Line pressure OK in R but low in D, 2, 1	Leakage in rear clutch area (seal rings, clutch seals)
Pressure low in D Fourth Gear Range	Overdrive clutch piston seal, or check ball problem
Pressure OK in 1, 2 but low in D3 and R	Leakage in front clutch area
Pressure OK in 2 but low in R and 1	Leakage in rear servo
Front servo pressure low in 2	Leakage in servo; broken servo ring or cracked servo piston
Pressure low in all positions	Clogged filter, stuck regulator valve, worn or faulty pump, low oil level
Governor pressure too high at idle speed	Governor pressure solenoid valve system fault. Refer to diagnostic book.
Governor pressure low at all mph figures	Faulty governor pressure solenoid, transmission control module, or governor pressure sensor
Lubrication pressure low at all throttle positions	Clogged fluid cooler or lines, seal rings leaking, worn pump bushings, pump, clutch retainer, or clogged filter.
Line pressure high	Output shaft plugged, sticky regulator valve
Line pressure low	Sticky regulator valve, clogged filter, worn pump

DIAGNOSIS AND TESTING (Continued)

CONVERTER STALL TEST

Stall testing involves determining maximum engine speed obtainable at full throttle with the rear wheels locked and the transmission in D range. This test checks the holding ability of the converter overrunning and transmission clutches.

WARNING: NEVER ALLOW ANYONE TO STAND DIRECTLY IN LINE WITH THE VEHICLE FRONT OR REAR DURING A STALL TEST. ALWAYS BLOCK THE WHEELS AND FULLY APPLY THE SERVICE AND PARKING BRAKES DURING THE TEST.

STALL TEST PROCEDURE

- (1) Connect tachometer to engine. Position tachometer so it can be viewed from driver's seat.
- (2) Drive vehicle to bring transmission fluid up to normal operating temperature. Vehicle can be driven on road or on chassis dynamometer, if available.
- (3) Check transmission fluid level. Add fluid if necessary.
- (4) Block front wheels.
- (5) Fully apply service and parking brakes.
- (6) Open throttle completely and record maximum engine speed registered on tachometer. It takes 4-10 seconds to reach max rpm. **Once max rpm has been achieved, do not hold wide open throttle for more than 4-5 seconds.**

CAUTION: Stalling the converter causes a rapid increase in fluid temperature. To avoid fluid overheating, hold the engine at maximum rpm for no more than 5 seconds. If engine exceeds 2500 rpm during the test, release the accelerator pedal immediately; transmission clutch slippage is occurring.

- (7) If a second stall test is required, cool down fluid before proceeding. Shift into NEUTRAL and run engine at 1000 rpm for 20-30 seconds to cool fluid.

STALL TEST ANALYSIS

Stall Speed Too High

If the stall speed exceeds 2500 rpm, transmission clutch slippage is indicated.

Stall Speed Low

Low stall speed with a properly tuned engine indicate a torque converter overrunning clutch problem. The condition should be confirmed by road testing. A stall speed 250-350 rpm below normal indicates the converter overrunning clutch is slipping. The vehicle also exhibits poor acceleration but operates normally once highway cruise speeds are reached. Torque converter replacement will be necessary.

Stall Speed Normal But Acceleration Poor

If stall speeds are normal (1800-2300 rpm) but abnormal throttle opening is required for acceleration, or to maintain cruise speed, the converter overrunning clutch is seized. The torque converter will have to be replaced.

Converter Noise During Test

A whining noise caused by fluid flow is normal during a stall test. However, loud metallic noises indicate a damaged converter. To confirm that the noise is originating from the converter, operate the vehicle at light throttle in DRIVE and NEUTRAL on a hoist and listen for noise coming from the converter housing.

AIR TESTING TRANSMISSION CLUTCH AND BAND OPERATION

Air-pressure testing can be used to check transmission front/rear clutch and band operation. The test can be conducted with the transmission either in the vehicle or on the work bench, as a final check, after overhaul.

Air-pressure testing requires that the oil pan and valve body be removed from the transmission. The servo and clutch apply passages are shown (Fig. 9).

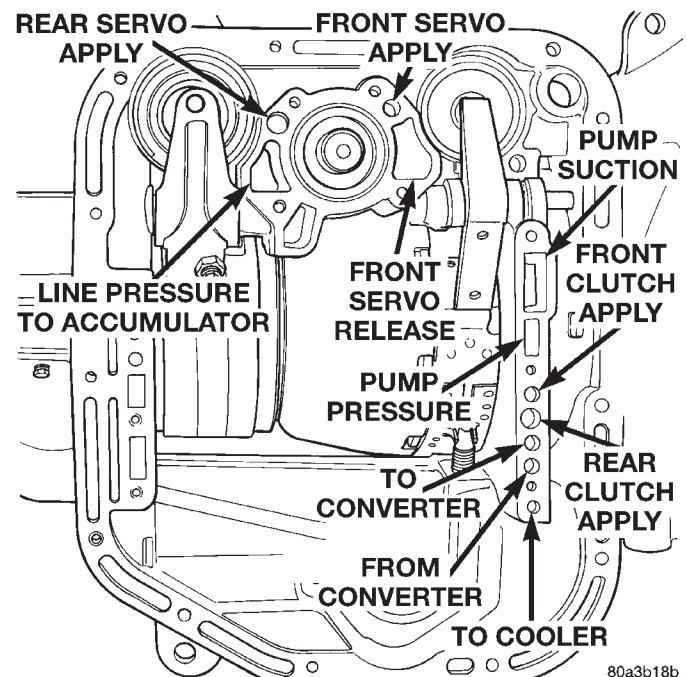


Fig. 9 Air Pressure Test Passages

Front Clutch Air Test

Place one or two fingers on the clutch housing and apply air pressure through front clutch apply passage. Piston movement can be felt and a soft thump heard as the clutch applies.

DIAGNOSIS AND TESTING (Continued)

Rear Clutch Air Test

Place one or two fingers on the clutch housing and apply air pressure through rear clutch apply passage. Piston movement can be felt and a soft thump heard as the clutch applies.

Front Servo Apply Air Test

Apply air pressure to the front servo apply passage. The servo rod should extend and cause the band to tighten around the drum. Spring pressure should release the servo when air pressure is removed.

Rear Servo Air Test

Apply air pressure to the rear servo apply passage. The servo rod should extend and cause the band to tighten around the drum. Spring pressure should release the servo when air pressure is removed.

CONVERTER HOUSING FLUID LEAK DIAGNOSIS

When diagnosing converter housing fluid leaks, two items must be established before repair.

- (1) Verify that a leak condition actually exists.
- (2) Determined the true source of the leak.

Some suspected converter housing fluid leaks may not be leaks at all. They may only be the result of residual fluid in the converter housing, or excess fluid spilled during factory fill or fill after repair. Converter housing leaks have several potential sources. Through careful observation, a leak source can be identified before removing the transmission for repair. Pump seal leaks tend to move along the drive hub and onto the rear of the converter. Pump O-ring or pump body leaks follow the same path as a seal leak (Fig. 10). Pump vent or pump attaching bolt leaks are generally deposited on the inside of the converter housing and not on the converter itself (Fig. 10). Pump seal or gasket leaks usually travel down the inside of the converter housing. Front band lever pin plug leaks are generally deposited on the housing and not on the converter.

TORQUE CONVERTER LEAK POINTS

Possible sources of converter leaks are:

- (1) Leaks at the weld joint around the outside diameter weld (Fig. 11).
- (2) Leaks at the converter hub weld (Fig. 11).

CONVERTER HOUSING AREA LEAK CORRECTION

- (1) Remove converter.
- (2) Tighten front band adjusting screw until band is tight around front clutch retainer. This prevents front/rear clutches from coming out when oil pump is removed.

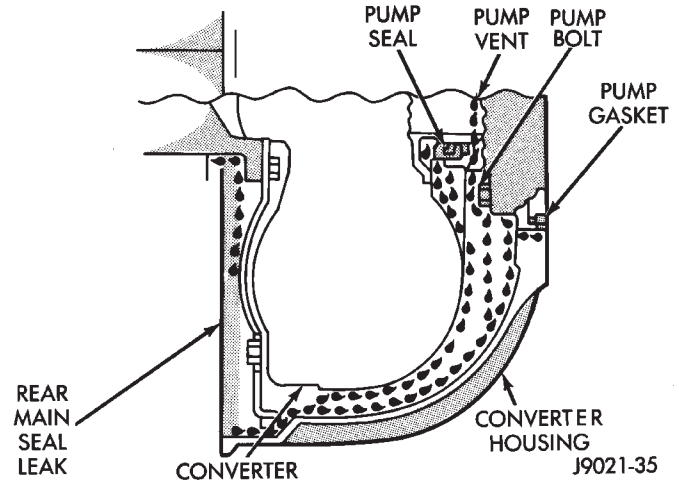


Fig. 10 Converter Housing Leak Paths

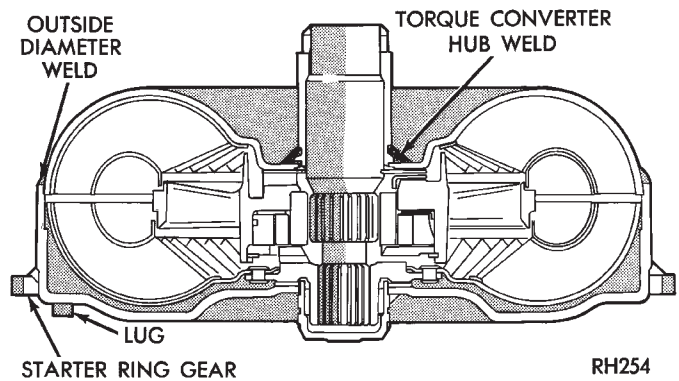


Fig. 11 Converter Leak Points—Typical

(3) Remove oil pump and remove pump seal. Inspect pump housing drainback and vent holes for obstructions. Clear holes with solvent and wire.

(4) Inspect pump bushing and converter hub. If bushing is scored, replace it. If converter hub is scored, either polish it with crocus cloth or replace converter.

(5) Install new pump seal, O-ring, and gasket. Replace oil pump if cracked, porous or damaged in any way. Be sure to loosen the front band before installing the oil pump, damage to the oil pump seal may occur if the band is still tightened to the front clutch retainer.

(6) Loosen kickdown lever pin access plug three turns. Apply Loctite 592, or Permatex No. 2 to plug threads and tighten plug to 17 N·m (150 in. lbs.) torque.

(7) Adjust front band.

(8) Lubricate pump seal and converter hub with transmission fluid or petroleum jelly and install converter.

(9) Install transmission and converter housing dust shield.

(10) Lower vehicle.

DIAGNOSIS AND TESTING (Continued)**DIAGNOSIS TABLES AND CHARTS—RE
TRANSMISSION**

The diagnosis charts provide additional reference when diagnosing a transmission fault. The charts provide general information on a variety of transmission, overdrive unit and converter clutch fault conditions.

The hydraulic flow charts in the Schematics and Diagrams section of this group, outline fluid flow and hydraulic circuitry. Circuit operation is provided for neutral, third, fourth and reverse gear ranges. Normal working pressures are also supplied for each of the gear ranges .

DIAGNOSIS CHARTS

CONDITION	POSSIBLE CAUSES	CORRECTION
HARSH ENGAGEMENT (FROM NEUTRAL TO DRIVE OR REVERSE)	1. Fluid Level Low	1. Add Fluid
	2. Throttle Linkage Misadjusted	2. Adjust linkage - setting may be too long.
	3. Mount and Driveline Bolts Loose	3. Check engine mount, transmission mount, propeller shaft, rear spring to body bolts, rear control arms, crossmember and axle bolt torque. Tighten loose bolts and replace missing bolts.
	4. U-Joint Worn/Broken	4. Remove propeller shaft and replace U-Joint.
	5. Axle Backlash Incorrect	5. Check per Service Manual. Correct as needed.
	6. Hydraulic Pressure Incorrect	6. Check pressure. Remove, overhaul or adjust valve body as needed.
	7. Band Misadjusted.	7. Adjust rear band.
	8. Valve Body Check Balls Missing.	8. Inspect valve body for proper check ball installation.
	9. Axle Pinion Flange Loose.	9. Replace nut and check pinion threads before installing new nut. Replace pinion gear if threads are damaged.
	10. Clutch, band or planetary component damaged.	10. Remove, disassemble and repair transmission as necessary.
	11. Converter Clutch Faulty.	11. Replace converter and flush cooler and line before installing new converter.
DELAYED ENGAGEMENT (FROM NEUTRAL TO DRIVE OR REVERSE)	1. Fluid Level Low.	1. Correct level and check for leaks.
	2. Filter Clogged.	2. Change filter.
	3. Gearshift Linkage Misadjusted.	3. Adjust linkage and repair linkage if worn or damaged.
	4. Torque Converter Drain Back (Oil drains from torque converter into transmission sump)	4. If vehicle moves normally after 5 seconds after shifting into gear, no repair is necessary. If longer, inspect pump bushing for wear. Replace pump house.
	5. Rear Band Misadjusted.	5. Adjust band.
	6. Valve Body Filter Plugged.	6. Replace fluid and filter. If oil pan and old fluid were full of clutch disc material and/or metal particles, overhaul will be necessary.
	7. Oil Pump Gears Worn/Damaged.	7. Remove transmission and replace oil pump.

DIAGNOSIS AND TESTING (Continued)

CONDITION	POSSIBLE CAUSES	CORRECTION
	8. Governor Circuit and Solenoid Valve Electrical Fault.	8. Test with DRB scan tool and repair as required.
	9. Hydraulic Pressure Incorrect.	9. Perform pressure test, remove transmission and repair as needed.
	10. Reaction Shaft Seal Rings Worn/Broken.	10. Remove transmission, remove oil pump and replace seal rings.
	11. Rear Clutch/Input Shaft, Rear Clutch Seal Rings Damaged.	11. Remove and disassemble transmission and repair as necessary.
	12. Regulator Valve Stuck.	12. Clean.
	13. Cooler Plugged.	13. Transfer case failure can plug cooler.
NO DRIVE RANGE (REVERSE OK)	1. Fluid Level Low.	1. Add fluid and check for leaks if drive is restored.
	2. Gearshift Linkage/Cable Loose/Misadjusted.	2. Repair or replace linkage components.
	3. Rear Clutch Burnt.	3. Remove and disassemble transmission and rear clutch and seals. Repair/replace worn or damaged parts as needed.
	4. Valve Body Malfunction.	4. Remove and disassemble valve body. Replace assembly if any valves or bores are damaged.
	5. Transmission Overrunning Clutch Broken.	5. Remove and disassemble transmission. Replace overrunning clutch.
	6. Input Shaft Seal Rings Worn/Damaged.	6. Remove and disassemble transmission. Replace seal rings and any other worn or damaged parts.
	7. Front Planetary Failed Broken.	7. Remove and repair.
NO DRIVE OR REVERSE (VEHICLE WILL NOT MOVE)	1. Fluid Level Low.	1. Add fluid and check for leaks if drive is restored.
	2. Gearshift Linkage/Cable Loose/Misadjusted.	2. Inspect, adjust and reassemble linkage as needed. Replace worn/damaged parts.
	3. U-Joint/Axle/Transfer Case Broken.	3. Perform preliminary inspection procedure for vehicle that will not move. Refer to procedure in diagnosis section.
	4. Filter Plugged.	4. Remove and disassemble transmission. Repair or replace failed components as needed. Replace filter. If filter and fluid contained clutch material or metal particles, an overhaul may be necessary. Perform lube flow test. Flush oil. Replace cooler as necessary.
	5. Oil Pump Damaged.	5. Perform pressure test to confirm low pressure. Replace pump body assembly if necessary.
	6. Valve Body Malfunctioned.	6. Check and inspect valve body. Replace valve body (as assembly) if any valve or bore is damaged. Clean and reassemble correctly if all parts are in good condition.

DIAGNOSIS AND TESTING (Continued)

CONDITION	POSSIBLE CAUSES	CORRECTION
	7. Transmission Internal Component Damaged.	7. Remove and disassemble transmission. Repair or replace failed components as needed.
	8. Park Sprag not Releasing - Check Stall Speed, Worn/Damaged/Stuck.	8. Remove, disassemble, repair.
	9. Torque Converter Damage.	9. Inspect and replace as required.
SHIFTS DELAYED OR ERRATIC (SHIFTS ALSO HARSH AT TIMES)	1. Fluid Level Low/High.	1. Correct fluid level and check for leaks if low.
	2. Fluid Filter Clogged.	2. Replace filter. If filter and fluid contained clutch material or metal particles, an overhaul may be necessary. Perform lube flow test.
	3. Throttle Linkage Misadjusted.	3. Adjust linkage as described in service section.
	4. Throttle Linkage Binding.	4. Check cable for binding. Check for return to closed throttle at transmission.
	5. Gearshift Linkage/Cable Misadjusted.	5. Adjust linkage/cable as described in service section.
	6. Clutch or Servo Failure.	6. Remove valve body and air test clutch, and band servo operation. Disassemble and repair transmission as needed.
	7. Governor Circuit Electrical Fault.	7. Test using DRB scan tool and repair as required.
	8. Front Band Misadjusted.	8. Adjust band.
	9. Pump Suction Passage Leak.	9. Check for excessive foam on dipstick after normal driving. Check for loose pump bolts, defective gasket. Replace pump assembly if needed.
NO REVERSE (D RANGES OK)	1. Gearshift Linkage/Cable Misadjusted/Damaged.	1. Repair or replace linkage parts as needed.
	2. Park Sprag Sticking.	2. Replace overdrive annulus gear.
	3. Rear Band Misadjusted/Worn.	3. Adjust band; replace.
	4. Valve Body Malfunction.	4. Remove and service valve body. Replace valve body if any valves or valve bores are worn or damaged.
	5. Rear Servo Malfunction.	5. Remove and disassemble transmission. Replace worn/damaged servo parts as necessary.
	6. Direct Clutch in Overdrive Worn	6. Disassemble overdrive. Replace worn or damaged parts.
	7. Front Clutch Burnt.	7. Remove and disassemble transmission. Replace worn, damaged clutch parts as required.

DIAGNOSIS AND TESTING (Continued)

CONDITION	POSSIBLE CAUSES	CORRECTION
HAS FIRST/REVERSE ONLY (NO 1-2 OR 2-3 UPSHIFT)	1. Governor Circuit Electrical Fault.	1. Test using DRB scan tool and repair as required.
	2. Valve Body Malfunction.	2. Repair stuck 1-2 shift valve or governor plug.
	3. Front Servo/Kickdown Band Damaged/Burned.	3. Repair/replace.
MOVES IN 2ND OR 3RD GEAR, ABRUPTLY DOWNSHIFTS TO LOW	1. Valve Body Malfunction.	1. Remove, clean and inspect. Look for stuck 1-2 valve or governor plug.
	2. Governor Valve Sticking.	2. Remove, clean and inspect. Replace faulty parts.
NO LOW GEAR (MOVES IN 2ND OR 3RD GEAR ONLY)	1. Governor Valve Sticking.	1. Remove governor, clean, inspect and repair as required.
	2. Governor Circuit Electrical Fault.	2. Test with DRB scan tool and repair as required.
	3. Valve Body Malfunction.	3. Remove, clean and inspect. Look for sticking 1-2 shift valve, 2-3 shift valve, governor plug or broken springs.
	4. Front Servo Piston Cocked in Bore.	4. Inspect servo and repair as required.
	5. Front Band Linkage Malfunction	5. Inspect linkage and look for bind in linkage.
NO KICKDOWN OR NORMAL DOWNSHIFT	1. Throttle Linkage Misadjusted.	1. Adjust linkage.
	2. Accelerator Pedal Travel Restricted.	2. Verify floor mat is not under pedal, repair worn accelerator cable or bent brackets.
	3. Valve Body Hydraulic Pressures Too High or Too Low Due to Valve Body Malfunction or Incorrect Hydraulic Control Pressure Adjustments.	3. Perform hydraulic pressure tests to determine cause and repair as required. Correct valve body pressure adjustments as required.
	4. Governor Circuit Electrical Fault.	4. Test with DRB scan tool and repair as required.
	5. Valve Body Malfunction.	5. Perform hydraulic pressure tests to determine cause and repair as required. Correct valve body pressure adjustments as required.
	6. TPS Malfunction.	6. Replace sensor, check with DRB scan tool.
	7. PCM Malfunction.	7. Check with DRB scan tool and replace if required.
	8. Valve Body Malfunction.	8. Repair sticking 1-2, 2-3 shift valves, governor plugs, 3-4 solenoid, 3-4 shift valve, 3-4 timing valve.

DIAGNOSIS AND TESTING (Continued)

CONDITION	POSSIBLE CAUSES	CORRECTION
STUCK IN LOW GEAR (WILL NOT UPSHIFT)	1. Throttle Linkage Misadjusted/ Stuck.	1. Adjust linkage and repair linkage if worn or damaged. Check for binding cable or missing return spring.
	2. Gearshift Linkage Misadjusted.	2. Adjust linkage and repair linkage if worn or damaged.
	3. Governor Component Electrical Fault.	3. Check operating pressures and test with DRB scan tool, repair faulty component.
	4. Front Band Out of Adjustment.	4. Adjust Band.
	5. Clutch or Servo Malfunction.	5. Air pressure check operation of clutches and bands. Repair faulty component.
CREEPS IN NEUTRAL	1. Gearshift Linkage Misadjusted.	1. Adjust linkage.
	2. Rear Clutch Dragging/Warped.	2. Disassemble and repair.
	3. Valve Body Malfunction.	3. Perform hydraulic pressure test to determine cause and repair as required.
BUZZING NOISE	1. Fluid Level Low	1. Add fluid and check for leaks.
	2. Shift Cable Misassembled.	2. Route cable away from engine and bell housing.
	3. Valve Body Misassembled.	3. Remove, disassemble, inspect valve body. Reassemble correctly if necessary. Replace assembly if valves or springs are damaged. Check for loose bolts or screws.
	4. Pump Passages Leaking	4. Check pump for porous casting, scores on mating surfaces and excess rotor clearance. Repair as required. Loose pump bolts.
	5. Cooling System Cooler Plugged.	5. Flow check cooler circuit. Repair as needed.
	6. Overrunning Clutch Damaged.	6. Replace clutch.
SLIPS IN REVERSE ONLY	1. Fluid Level Low.	1. Add fluid and check for leaks.
	2. Gearshift Linkage Misadjusted.	2. Adjust linkage.
	3. Rear Band Misadjusted.	3. Adjust band.
	4. Rear Band Worn.	4. Replace as required.
	5. Overdrive Direct Clutch Worn.	5. Disassemble overdrive. Repair as needed.
	6. Hydraulic Pressure Too Low.	6. Perform hydraulic pressure tests to determine cause.
	7. Rear Servo Leaking.	7. Air pressure check clutch-servo operation and repair as required.
	8. Band Linkage Binding.	8. Inspect and repair as required.

DIAGNOSIS AND TESTING (Continued)

CONDITION	POSSIBLE CAUSES	CORRECTION
SLIPS IN FORWARD DRIVE RANGES	1. Fluid Level Low.	1. Add fluid and check for leaks.
	2. Fluid Foaming.	2. Check for high oil level, bad pump gasket or seals, dirt between pump halves and loose pump bolts. Replace pump if necessary.
	3. Throttle Linkage Misadjusted.	3. Adjust linkage.
	4. Gearshift Linkage Misadjusted.	4. Adjust linkage.
	5. Rear Clutch Worn.	5. Inspect and replace as needed.
	6. Low Hydraulic Pressure Due to Worn Pump, Incorrect Control Pressure Adjustments, Valve Body Warpage or Malfunction, Sticking, Leaking Seal Rings, Clutch Seals Leaking, Servo Leaks, Clogged Filter or Cooler Lines	6. Perform hydraulic and air pressure tests to determine cause.
	7. Rear Clutch Malfunction, Leaking Seals or Worn Plates.	7. Air pressure check clutch-servo operation and repair as required.
	8. Overrunning Clutch Worn, Not Holding (Slips in 1 Only).	8. Replace Clutch.
SLIPS IN LOW GEAR "D" ONLY, BUT NO IN 1 POSITION	Overrunning Clutch Faulty.	Replace overrunning clutch.
GROWLING, GRATING OR SCRAPING NOISES	1. Drive Plate Broken.	1. Replace.
	2. Torque Converter Bolts Hitting Dust Shield.	2. Dust shield bent. Replace or repair.
	3. Planetary Gear Set Broken/ Seized.	3. Check for debris in oil pan and repair as required.
	4. Overrunning Clutch Worn/ Broken.	4. Inspect and check for debris in oil pan. Repair as required.
	5. Oil Pump Components Scored/Binding.	5. Remove, inspect and repair as required.
	6. Output Shaft Bearing or Bushing Damaged.	6. Remove, inspect and repair as required.
	7. Clutch Operation Faulty.	7. Perform air pressure check and repair as required.
	8. Front and Rear Bands Misadjusted.	8. Adjust bands.
DRAGS OR LOCKS UP	1. Fluid Level Low.	1. Check and adjust level.
	2. Clutch Dragging/Failed	2. Air pressure check clutch operation and repair as required.
	3. Front or Rear Band Misadjusted.	3. Adjust bands.
	4. Case Leaks Internally.	4. Check for leakage between passages in case.
	5. Servo Band or Linkage Malfunction.	5. Air pressure check servo operation and repair as required.
	6. Overrunning Clutch Worn.	6. Remove and inspect clutch. Repair as required.

DIAGNOSIS AND TESTING (Continued)

CONDITION	POSSIBLE CAUSES	CORRECTION
	7. Planetary Gears Broken.	7. Remove, inspect and repair as required (look for debris in oil pan).
	8. Converter Clutch Dragging.	8. Check for plugged cooler. Perform flow check. Inspect pump for excessive side clearance. Replace pump as required.
NO 4-3 DOWNSHIFT	1. Circuit Wiring and/or Connectors Shorted.	1. Test wiring and connectors with test lamp and volt/ohmmeter. Repair wiring as necessary. Replace connectors and/or harnesses as required.
	2. PCM Malfunction.	2. Check PCM operation with DRB scan tool. Replace PCM only if faulty.
	3. TPS Malfunction	3. Check TPS with DRB scan tool at PCM.
	4. Lockup Solenoid Not Venting.	4. Remove valve body and replace solenoid assembly if plugged or shorted.
	5. Overdrive Solenoid Not Venting.	5. Remove valve body and replace solenoid if plugged or shorted.
	6. Valve Body Valve Sticking.	6. Repair stuck 3-4 shift valve or lockup timing valve.
NO 4-3 DOWNSHIFT WHEN CONTROL SWITCH IS TURNED OFF	1. Control Switch Open/Shorted.	1. Test and replace switch if faulty.
	2. Overdrive Solenoid Connector Shorted.	2. Test solenoids and replace if seized or shorted.
	3. PCM Malfunction.	3. Test with DRB scan tool. Replace PCM if faulty.
	4. Valve Body Stuck Valves.	4. Repair stuck 3-4, lockup or lockup timing valve.
CLUNK NOISE FROM DRIVELINE ON CLOSED THROTTLE 4-3 DOWNSHIFT	1. Transmission Fluid Low.	1. Add Fluid.
	2. Throttle Cable Misadjusted.	2. Adjust cable.
	3. Overdrive Clutch Select Spacer Wrong Spacer.	3. Replace overdrive piston thrust plate spacer.
3-4 UPSHIFT OCCURS IMMEDIATELY AFTER 2-3 SHIFT	1. Overdrive Solenoid Connector or Wiring Shorted.	1. Test connector and wiring for loose connections, shorts or ground and repair as needed.
	2. TPS Malfunction.	2. Test TPS and replace as necessary. Check with DRB scan tool.
	3. PCM Malfunction.	3. Test PCM with DRB scan tool and replace controller if faulty.
	4. Overdrive Solenoid Malfunction.	4. Replace solenoid.
	5. Valve Body Malfunction.	5. Remove, disassemble, clean and inspect valve body components. Make sure all valves and plugs slide freely in bores. Polish valves with crocus cloth if needed.
WHINE/NOISE RELATED TO ENGINE SPEED	1. Fluid Level Low.	1. Add fluid and check for leaks.
	2. Shift Cable Incorrect Routing.	2. Check shift cable for correct routing. Should not touch engine or bell housing.

DIAGNOSIS AND TESTING (Continued)

CONDITION	POSSIBLE CAUSES	CORRECTION
NO 3-4 UPSHIFT	1. Dash O/D Switch In OFF Position.	1. Turn control switch to ON position.
	2. Overdrive Circuit Fuse Blown.	2. Replace fuse. Determine why fuse failed and repair as necessary (i.e., shorts or grounds in circuit).
	3. O/D Switch Wire Shorted/Open Cut.	3. Check wires/connections with 12V test lamp and voltmeter. Repair damaged or loose wire/connection as necessary.
	4. Distance or Coolant Sensor Malfunction.	4. Test both sensors with test lamp or volt/ohmmeter and replace faulty sensor.
	5. TPS Malfunction.	5. Check with DRB scan tool and replace if necessary.
	6. Neutral Switch to PCM Wire Shorted/Cut.	6. Test switch as described in service section and replace if necessary. Engine no start.
	7. PCM Malfunction.	7. Check with DRB scan tool and replace if necessary.
	8. Overdrive Solenoid Shorted/Open.	8. Replace solenoid if shorted or open and repair loose or damaged wires (DRB scan tool).
	9. Solenoid Feed Orifice in Valve Body Blocked.	9. Remove, disassemble, and clean valve body thoroughly. Check feed orifice.
	10. Overdrive Clutch Failed.	10. Disassemble overdrive and repair as needed.
	11. Hydraulic Pressure Low.	11. Pressure test transmission to determine cause.
	12. Valve Body Valve Stuck.	12. Repair stuck 3-4 shift valve, 3-4 timing valve.
	13. O/D Piston Incorrect Spacer.	13. Remove unit, check end play and install correct spacer.
	14. Overdrive Piston Seal Failure.	14. Replace both seals.
	15. O/D Check Valve/Orifice Failed.	15. Check for free movement and secure assembly (in piston retainer). Check ball bleed orifice.
SLIPS IN OVERDRIVE FOURTH GEAR	1. Fluid Level Low.	1. Add fluid and check for leaks.
	2. Overdrive Clutch Pack Worn.	2. Remove overdrive unit and rebuild clutch pack.
	3. Overdrive Piston Retainer Bleed Orifice Blown Out.	3. Disassemble transmission, remove retainer and replace orifice.
	4. Overdrive Piston or Seal Malfunction.	4. Remove overdrive unit. Replace seals if worn. Replace piston if damaged. If piston retainer is damaged, remove and disassemble the transmission.
	5. 3-4 Shift Valve, Timing Valve or Accumulator Malfunction.	5. Remove and overhaul valve body. Replace accumulator seals. Make sure all valves operate freely in bores and do not bind or stick. Make sure valve body screws are correctly tightened and separator plates are properly positioned.

DIAGNOSIS AND TESTING (Continued)

CONDITION	POSSIBLE CAUSES	CORRECTION
	6. Overdrive Unit Thrust Bearing Failure.	6. Disassemble overdrive unit and replace thrust bearing (NO. 1 thrust bearing is between overdrive piston and clutch hub; NO. 2 thrust bearing is between the planetary gear and the direct clutch spring plate; NO. 3 thrust bearing is between overrunning clutch hub and output shaft).
	7. O/D Check Valve/Bleed Orifice Failure.	7. Check for function/secure orifice insert in O/D piston retainer.
DELAYED 3-4 UPSHIFT (SLOW TO ENGAGE)	1. Fluid Level Low.	1. Add fluid and check for leaks.
	2. Throttle Valve Cable Misadjusted.	2. Adjust throttle valve cable.
	3. Overdrive Clutch Pack Worn/ Burnt.	3. Remove unit and rebuild clutch pack.
	4. TPS Faulty.	4. Test with DRB scan tool and replace TPS.
	5. Overdrive Clutch Bleed Orifice Plugged.	5. Disassemble transmission and replace orifice.
	6. Overdrive Solenoid or Wiring Shorted/Open.	6. Test solenoid and check wiring for loose/corroded connections or shorts/grounds. Replace solenoid if faulty and repair wiring if necessary.
	7. Overdrive Excess Clearance	7. Remove unit. Measure end play and select proper spacer.
	8. O/D Check Valve Missing or Stuck.	8. Check for presence of check valve. Repair or replace as required.
TORQUE CONVERTER LOCKS UP IN SECOND AND/OR THIRD GEAR	Lockup Solenoid, Relay or Wiring Shorted/Open.	Test solenoid, relay and wiring for continuity, shorts or grounds. Replace solenoid and relay if faulty. Repair wiring and connectors as necessary.
HARSH 1-2, 2-3, 3-4 OR 3-2 SHIFTS	Lockup Solenoid Malfunction.	Remove valve body and replace solenoid assembly.
NO START IN PARK OR NEUTRAL	1. Gearshift Linkage/Cable Misadjusted.	1. Adjust linkage/cable.
	2. Neutral Switch Wire Open/Cut.	2. Check continuity with test lamp. Repair as required.
	3. Neutral Switch Faulty.	3. Refer to service section for test and replacement procedure.
	4. Neutral Switch Connect Faulty.	4. Connectors spread open. Repair.
	5. Valve Body Manual Lever Assembly Bent/Worn/Broken.	5. Inspect lever assembly and replace if damaged.
NO REVERSE (OR SLIPS IN REVERSE)	1. Direct Clutch Pack (front clutch) Worn.	1. Disassemble unit and rebuild clutch pack.
	2. Rear Band Misadjusted.	2. Adjust band.
	3. Front Clutch Malfunctioned/ Burned.	3. Air-pressure test clutch operation. Remove and rebuild if necessary.
	4. Overdrive Thrust Bearing Failure.	4. Disassemble geartrain and replace bearings.
	5. Direct Clutch Spring Collapsed/ Broken.	5. Remove and disassemble unit. Check clutch position and replace spring.

DIAGNOSIS AND TESTING (Continued)

CONDITION	POSSIBLE CAUSES	CORRECTION
OIL LEAKS.	1. Speedometer Adapter Leaks.	1. Replace both adapter seals.
	2. Fluid Lines and Fittings Loose/Leaks/Damaged.	2. Tighten fittings. If leaks persist, replace fittings and lines if necessary.
	3. Fill Tube (where tube enters case) Leaks/Damaged.	3. Replace O-ring seal. Inspect tube for cracks in fill tube.
	4. Pressure Port Plug Loose Loose/Damaged.	4. Tighten to correct torque. Replace plug or reseal if leak persists.
	5. Pan Gasket Leaks.	5. Tighten pan screws (150 in. lbs.). If leaks persist, replace gasket.
	6. Valve Body Manual Lever Shaft Seal Leaks/Worn.	6. Replace shaft seal.
	7. Rear Bearing Access Plate Leaks.	7. Replace gasket. Tighten screws.
	8. Gasket Damaged or Bolts are Loose.	8. Replace bolts or gasket or tighten both.
	9. Adapter/Extension Gasket Damaged Leaks/Damaged.	9. Replace gasket.
	10. Neutral Switch Leaks/Damaged.	10. Replace switch and gasket.
	11. Converter Housing Area Leaks.	11. Check for leaks at seal caused by worn seal or burr on converter hub (cutting seal), worn bushing, missing oil return, oil in front pump housing or hole plugged. Check for leaks past O-ring seal on pump or past pump-to-case bolts; pump housing porous, oil coming out vent due to overfill or leak past front band shaft access plug.
	12. Pump Seal Leaks/Worn/Damaged.	12. Replace seal.
	13. Torque Converter Weld Leak/Cracked Hub.	13. Replace converter.
	14. Case Porosity Leaks.	14. Replace case.
NOISY OPERATION IN FOURTH GEAR ONLY	1. Overdrive Clutch Discs, Plates or Snap Rings Damaged.	1. Remove unit and rebuild clutch pack.
	2. Overdrive Piston or Planetary Thrust Bearing Damaged.	2. Remove and disassemble unit. Replace either thrust bearing if damaged.
	3. Output Shaft Bearings Scored/Damaged.	3. Remove and disassemble unit. Replace either bearing if damaged.
	4. Planetary Gears Worn/Chipped.	4. Remove and overhaul overdrive unit.
	5. Overdrive Unit Overrunning Clutch Rollers Worn/Scored.	5. Remove and overhaul overdrive unit.

SERVICE PROCEDURES

FLUID LEVEL CHECK

Transmission fluid level should be checked monthly under normal operation. If the vehicle is used for trailer towing or similar heavy load hauling, check fluid level and condition weekly. Fluid level is checked with the engine running at curb idle speed, the transmission in NEUTRAL and the transmission fluid at normal operating temperature.

FLUID LEVEL CHECK PROCEDURE

- (1) Transmission fluid must be at normal operating temperature for accurate fluid level check. Drive vehicle if necessary to bring fluid temperature up to normal hot operating temperature of 82°C (180°F).
- (2) Position vehicle on level surface.
- (3) Start and run engine at curb idle speed.
- (4) Apply parking brakes.
- (5) Shift transmission momentarily into all gear ranges. Then shift transmission back to Neutral.
- (6) Clean top of filler tube and dipstick to keep dirt from entering tube.
- (7) Remove dipstick (Fig. 12) and check fluid level as follows:
 - (a) Correct acceptable level is in crosshatch area.
 - (b) Correct maximum level is to MAX arrow mark.
 - (c) Incorrect level is at or below MIN line.
 - (d) If fluid is low, add only enough Mopar® ATF Plus 3 to restore correct level. Do not overfill.

CAUTION: Do not overfill the transmission. Overfilling may cause leakage out the pump vent which can be mistaken for a pump seal leak. Overfilling will also cause fluid aeration and foaming as the excess fluid is picked up and churned by the gear train. This will significantly reduce fluid life.

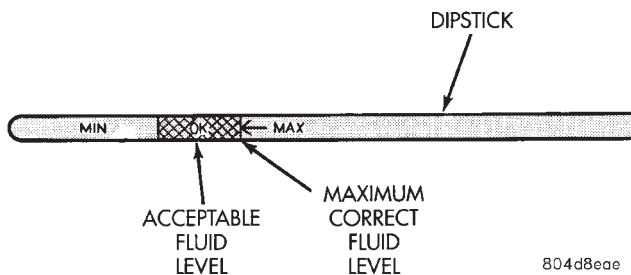


Fig. 12 Dipstick Fluid Level Marks—Typical

FLUID AND FILTER REPLACEMENT

Refer to the Maintenance Schedules in Group 0, Lubrication and Maintenance, for proper service intervals. The service fluid fill after a filter change is approximately 3.8 liters (4.0 quarts).

REMOVAL

- (1) Hoist and support vehicle on safety stands.
- (2) Place a large diameter shallow drain pan beneath the transmission pan.
- (3) Remove bolts holding front and sides of pan to transmission (Fig. 13).
- (4) Loosen bolts holding rear of pan to transmission.
- (5) Slowly separate front of pan away from transmission allowing the fluid to drain into drain pan.
- (6) Hold up pan and remove remaining bolt holding pan to transmission.
- (7) While holding pan level, lower pan away from transmission.
- (8) Pour remaining fluid in pan into drain pan.
- (9) Remove screws holding filter to valve body (Fig. 14).
- (10) Separate filter from valve body and pour fluid in filter into drain pan.
- (11) Dispose of used trans fluid and filter properly.

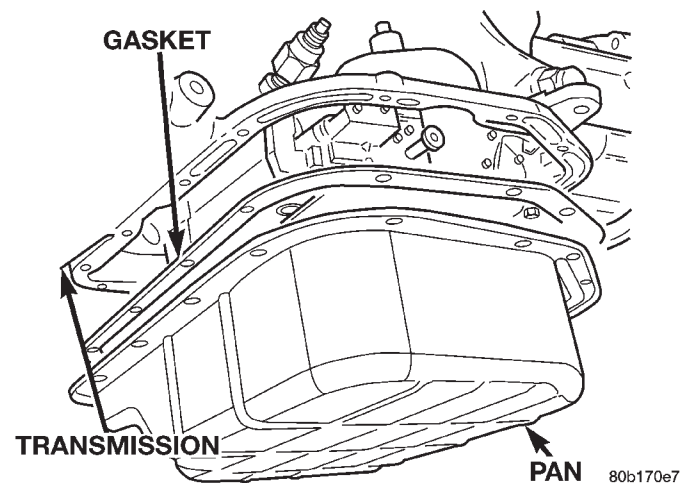


Fig. 13 Transmission Pan—Typical

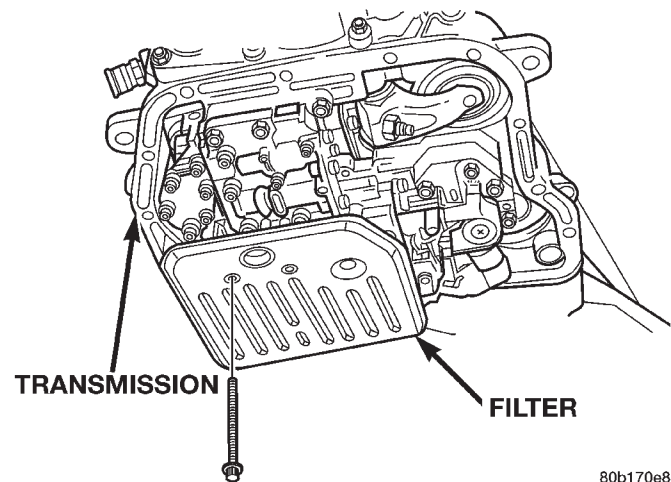


Fig. 14 Transmission Filter—Typical

SERVICE PROCEDURES (Continued)

INSPECTION

Inspect bottom of pan and magnet for excessive amounts of metal. A light coating of clutch or band material on the bottom of the pan does not indicate a problem unless accompanied by slipping condition or shift lag. If fluid and pan are contaminated with excessive amounts or debris, refer to the diagnosis section of this group.

Check the adjustment of the front and rear bands, adjust if necessary.

CLEANING

(1) Using a suitable solvent, clean pan and magnet.

(2) Using a suitable gasket scraper, clean gasket material from gasket surface of transmission case and the gasket flange around the pan.

INSTALLATION

(1) Place replacement filter in position on valve body.

(2) Install screws to hold filter to valve body (Fig. 14). Tighten screws to 4 N·m (35 in. lbs.) torque.

(3) Place new gasket in position on pan and install pan on transmission.

(4) Place pan in position on transmission.

(5) Install screws to hold pan to transmission (Fig. 13). Tighten bolts to 17 N·m (150 in. lbs.) torque.

(6) Lower vehicle and fill transmission with Mopar® ATF Plus 3, type 7176 fluid.

TRANSMISSION FILL PROCEDURE

To avoid overfilling transmission after a fluid change or overhaul, perform the following procedure:

(1) Remove dipstick and insert clean funnel in transmission fill tube.

(2) Add following initial quantity of Mopar® ATF Plus 3 to transmission:

(a) If only fluid and filter were changed, add **3 pints (1-1/2 quarts)** of ATF Plus 3 to transmission.

(b) If transmission was completely overhauled, torque converter was replaced or drained, and cooler was flushed, add **12 pints (6 quarts)** of ATF Plus 3 to transmission.

(3) Apply parking brakes.

(4) Start and run engine at normal curb idle speed.

(5) Apply service brakes, shift transmission through all gear ranges then back to NEUTRAL, set parking brake, and leave engine running at curb idle speed.

(6) Remove funnel, insert dipstick and check fluid level. If level is low, **add fluid to bring level to MIN mark on dipstick.** Check to see if the oil level is equal on both sides of the dipstick. If one side is noticeably higher than the other, the dipstick has

picked up some oil from the dipstick tube. Allow the oil to drain down the dipstick tube and re-check.

(7) Drive vehicle until transmission fluid is at normal operating temperature.

(8) With the engine running at curb idle speed, the gear selector in NEUTRAL, and the parking brake applied, check the transmission fluid level.

CAUTION: Do not overfill transmission, fluid foaming and shifting problems can result.

(9) Add fluid to bring level up to MAX arrow mark.

When fluid level is correct, shut engine off, release park brake, remove funnel, and install dipstick in fill tube.

CONVERTER DRAINBACK CHECK VALVE SERVICE

The converter drainback check valve is located in the cooler outlet (pressure) line near the radiator lower tank. The valve prevents fluid drainback when the vehicle is parked for lengthy periods. The valve check ball is spring loaded and has an opening pressure of approximately 2 psi.

The valve is serviced as an assembly; it is not repairable. Do not clean the valve if restricted, or contaminated by sludge, or debris. If the valve fails, or if a transmission malfunction occurs that generates sludge and/or clutch particles and metal shavings, the valve must be replaced.

The valve must be removed whenever the cooler and lines are reverse flushed. The valve can be flow tested when necessary. The procedure is exactly the same as for flow testing a cooler.

If the valve is restricted, installed backwards, or in the wrong line, it will cause an overheating condition and possible transmission failure.

CAUTION: The drainback valve is a one-way flow device. It must be properly oriented in terms of flow direction for the cooler to function properly. The valve must be installed in the pressure line. Otherwise flow will be blocked and would cause an overheating condition and eventual transmission failure.

OIL PUMP VOLUME CHECK

After the new or repaired transmission has been installed, fill to the proper level with Mopar® ATF PLUS 3 (Type 7176) automatic transmission fluid. The volume should be checked using the following procedure:

(1) Disconnect the **From cooler** line at the transmission and place a collecting container under the disconnected line.

SERVICE PROCEDURES (Continued)

CAUTION: With the fluid set at the proper level, fluid collection should not exceed (1) quart or internal damage to the transmission may occur.

(2) Run the engine **at curb idle speed**, with the shift selector in neutral.

(3) If fluid flow is intermittent or it takes more than 20 seconds to collect one quart of ATF PLUS 3, disconnect the **To Cooler** line at the transaxle.

(4) Refill the transaxle to proper level and recheck pump volume.

(5) If flow is found to be within acceptable limits, replace the cooler. Then fill transmission to the proper level, using Mopar® ATF PLUS 3 (Type 7176) automatic transmission fluid.

(6) If fluid flow is still found to be inadequate, check the line pressure using the Transaxle Hydraulic Pressure Test procedure.

FLUSHING COOLERS AND TUBES

When a transmission failure has contaminated the fluid, the oil cooler(s) must be flushed. The cooler bypass valve in the transmission must be replaced also. The torque converter must also be replaced. This will insure that metal particles or sludged oil are not later transferred back into the reconditioned (or replaced) transmission.

The only recommended procedure for flushing coolers and lines is to use Tool 6906 Cooler Flusher.

WARNING: WEAR PROTECTIVE EYEWEAR THAT MEETS THE REQUIREMENTS OF OSHA AND ANSI Z87.1-1968. WEAR STANDARD INDUSTRIAL RUBBER GLOVES.

KEEP LIGHTED CIGARETTES, SPARKS, FLAMES, AND OTHER IGNITION SOURCES AWAY FROM THE AREA TO PREVENT THE IGNITION OF COMBUSTIBLE LIQUIDS AND GASES. KEEP A CLASS (B) FIRE EXTINGUISHER IN THE AREA WHERE THE FLUSHER WILL BE USED.

KEEP THE AREA WELL VENTILATED.

DO NOT LET FLUSHING SOLVENT COME IN CONTACT WITH YOUR EYES OR SKIN: IF EYE CONTAMINATION OCCURS, FLUSH EYES WITH WATER FOR 15 TO 20 SECONDS. REMOVE CONTAMINATED CLOTHING AND WASH AFFECTED SKIN WITH SOAP AND WATER. SEEK MEDICAL ATTENTION.

COOLER FLUSH USING TOOL 6906

(1) Remove cover plate filler plug on Tool 6906. Fill reservoir 1/2 to 3/4 full of fresh flushing solution. Flushing solvents are petroleum based solutions generally used to clean automatic transmission components. **DO NOT** use solvents containing acids, water, gasoline, or any other corrosive liquids.

(2) Reinstall filler plug on Tool 6906.

(3) Verify pump power switch is turned OFF. Connect red alligator clip to positive (+) battery post. Connect black (-) alligator clip to a good ground.

(4) Disconnect the cooler lines at the transmission.

NOTE: When flushing transmission cooler and lines, ALWAYS reverse flush.

(5) Connect the BLUE pressure line to the OUTLET (From) cooler line.

(6) Connect the CLEAR return line to the INLET (To) cooler line

(7) Turn pump ON for two to three minutes to flush cooler(s) and lines. Monitor pressure readings and clear return lines. Pressure readings should stabilize below 20 psi. for vehicles equipped with a single cooler and 30 psi. for vehicles equipped with dual coolers. If flow is intermittent or exceeds these pressures, replace cooler.

(8) Turn pump OFF.

(9) Disconnect CLEAR suction line from reservoir at cover plate. Disconnect CLEAR return line at cover plate, and place it in a drain pan.

(10) Turn pump ON for 30 seconds to purge flushing solution from cooler and lines. Turn pump OFF.

(11) Place CLEAR suction line into a one quart container of Mopar® ATF Plus 3, type 7176 automatic transmission fluid.

(12) Turn pump ON until all transmission fluid is removed from the one quart container and lines. This purges any residual cleaning solvent from the transmission cooler and lines. Turn pump OFF.

(13) Disconnect alligator clips from battery. Reconnect flusher lines to cover plate, and remove flushing adapters from cooler lines.

ALUMINUM THREAD REPAIR

Damaged or worn threads in the aluminum transaxle case and valve body can be repaired by the use of Heli-Coils, or equivalent. This repair consists of drilling out the worn-out damaged threads. Then tap the hole with a special Heli-Coil tap, or equivalent, and installing a Heli-Coil insert, or equivalent, into the hole. This brings the hole back to its original thread size.

Heli-Coil, or equivalent, tools and inserts are readily available from most automotive parts suppliers.

REMOVAL AND INSTALLATION

TRANSMISSION

The overdrive unit can be removed and serviced separately. It is not necessary to remove the entire transmission assembly to perform overdrive unit repairs.

REMOVAL AND INSTALLATION (Continued)

If only the overdrive unit requires service, refer to the overdrive unit removal and installation procedures.

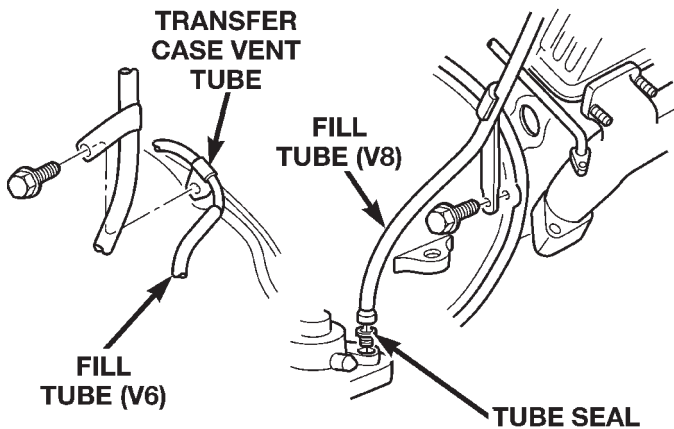
CAUTION: The transmission and torque converter must be removed as an assembly to avoid component damage. The converter drive plate, pump bushing, or oil seal can be damaged if the converter is left attached to the driveplate during removal. Be sure to remove the transmission and converter as an assembly.

REMOVAL

- (1) Disconnect battery negative cable.
- (2) Disconnect and lower or remove necessary exhaust components.
- (3) Remove engine-to-transmission bending braces.
- (4) Disconnect fluid cooler lines at transmission.
- (5) Remove starter motor.
- (6) Disconnect and remove crankshaft position sensor. Retain sensor attaching bolts.

CAUTION: The crankshaft position sensor will be damaged if the transmission is removed, or installed, while the sensor is still bolted to the engine block, or transmission (4.0L only). To avoid damage, be sure to remove the sensor before removing the transmission.

- (7) Remove torque converter access cover.
- (8) If transmission is being removed for overhaul, remove transmission oil pan, drain fluid and reinstall pan.
- (9) Remove fill tube bracket bolts and pull tube out of transmission. Retain fill tube seal. On 4 x 4 models, it will also be necessary to remove bolt attaching transfer case vent tube to converter housing (Fig. 15).



80b170f3

Fig. 15 Fill Tube Attachment

(10) Mark torque converter and drive plate for assembly alignment. Note that bolt holes in crankshaft flange, drive plate and torque converter all have one offset hole.

(11) Rotate crankshaft in clockwise direction until converter bolts are accessible. Then remove bolts one at a time. Rotate crankshaft with socket wrench on dampener bolt.

(12) Mark propeller shaft and axle yokes for assembly alignment. Then disconnect and remove propeller shaft. On 4 x 4 models, remove both propeller shafts.

(13) Disconnect wires from park/neutral position switch, transmission solenoid, and vehicle speed sensor.

(14) Disconnect gearshift cable from transmission manual valve lever.

(15) Disconnect throttle valve cable from transmission bracket and throttle valve lever.

(16) On 4 x 4 models, disconnect shift rod from transfer case shift lever or remove shift lever from transfer case.

(17) Disconnect transmission fluid cooler lines at transmission fittings and clips.

(18) Support rear of engine with safety stand or jack.

(19) Raise transmission slightly with service jack to relieve load on crossmember and supports.

(20) Remove bolts securing rear support and cushion to transmission and crossmember. Raise transmission slightly, slide exhaust hanger arm from bracket and remove rear support.

(21) Remove bolts attaching crossmember to frame and remove crossmember.

(22) On 4 x 4 models, remove transfer case.

(23) Remove all converter housing bolts.

(24) Carefully work transmission and torque converter assembly rearward off engine block dowels.

(25) Hold torque converter in place during transmission removal.

(26) Lower transmission and remove assembly from under the vehicle.

(27) To remove torque converter, carefully slide torque converter out of the transmission.

INSTALLATION

(1) Check torque converter hub and hub drive notches for sharp edges burrs, scratches, or nicks. Polish the hub and notches with 320/400 grit paper and crocus cloth if necessary. The hub must be smooth to avoid damaging pump seal at installation.

(2) Lubricate converter drive hub and oil pump seal lip with transmission fluid.

(3) Lubricate converter pilot hub with transmission fluid.

(4) Align converter and oil pump.

REMOVAL AND INSTALLATION (Continued)

(5) Carefully insert converter in oil pump. Then rotate converter back and forth until fully seated in pump gears.

(6) Check converter seating with steel scale and straightedge (Fig. 16). Surface of converter lugs should be 1/2 in. to rear of straightedge when converter is fully seated.

(7) Temporarily secure converter with C-clamp.

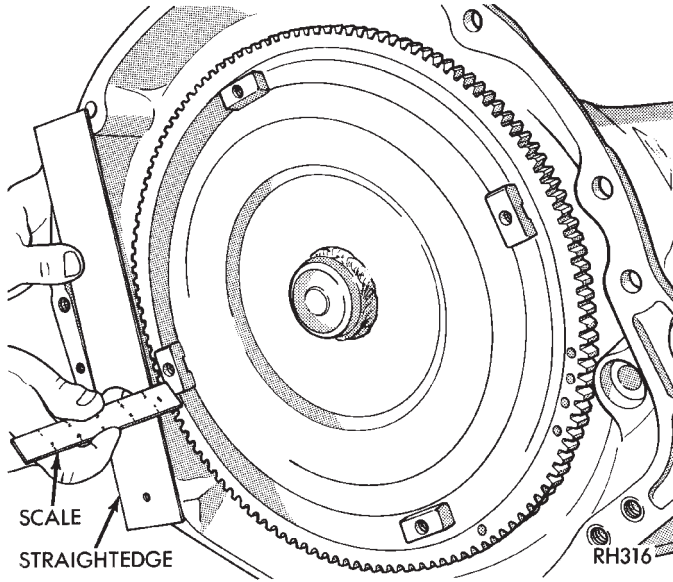


Fig. 16 Typical Method Of Checking Converter Seating

(8) Position transmission on jack and secure it with chains.

(9) Check condition of converter driveplate. Replace the plate if cracked, distorted or damaged. **Also be sure transmission dowel pins are seated in engine block and protrude far enough to hold transmission in alignment.**

(10) Raise transmission and align converter with drive plate and converter housing with engine block.

(11) Move transmission forward. Then raise, lower or tilt transmission to align converter housing with engine block dowels.

(12) Rotate converter so alignment marks scribed on converter are aligned with mark on driveplate.

(13) Carefully work transmission forward and over engine block dowels until converter hub is seated in crankshaft.

(14) Install bolts attaching converter housing to engine.

(15) Install rear support. Then lower transmission onto crossmember and install bolts attaching transmission mount to crossmember.

(16) Remove engine support fixture.

(17) Install crankshaft position sensor.

(18) Install vehicle speed sensor and speedometer adapter.

(19) Install new plastic retainer grommet on any shift linkage rod or lever that was disconnected. Grommets should not be reused. Use pry tool to remove rod from grommet and cut away old grommet. Use pliers to snap new grommet into lever and to snap rod into grommet at assembly.

(20) Connect gearshift and throttle valve cable to transmission.

(21) Connect wires to park/neutral position switch, transmission solenoid(s) and oxygen sensor. Be sure transmission harnesses are properly routed.

CAUTION: It is essential that correct length bolts be used to attach the converter to the driveplate. Bolts that are too long will damage the clutch surface inside the converter.

(22) Install torque converter-to-driveplate bolts. Tighten bolts to 31 N·m (270 in. lbs.).

(23) Install converter housing access cover.

(24) Install starter motor and cooler line bracket.

(25) Connect cooler lines to transmission.

(26) Install transmission fill tube. Install new seal on tube before installation.

(27) Install exhaust components.

(28) Install transfer case.

(29) Align and connect propeller shaft(s).

(30) Adjust gearshift linkage and throttle valve cable if necessary.

(31) Lower vehicle.

(32) Fill transmission with Mopar® ATF Plus 3, Type 7176 fluid.

TORQUE CONVERTER**REMOVAL**

(1) Remove transmission and torque converter from vehicle.

(2) Place a suitable drain pan under the converter housing end of the transmission.

CAUTION: Verify that transmission is secure on the lifting device or work surface, the center of gravity of the transmission will shift when the torque converter is removed creating an unstable condition.

The torque converter is a heavy unit. Use caution when separating the torque converter from the transmission.

(3) Pull the torque converter forward until the center hub clears the oil pump seal.

(4) Separate the torque converter from the transmission.

INSTALLATION

Check converter hub and drive notches for sharp edges, burrs, scratches, or nicks. Polish the hub and

REMOVAL AND INSTALLATION (Continued)

notches with 320/400 grit paper or crocus cloth if necessary. The hub must be smooth to avoid damaging the pump seal at installation.

- (1) Lubricate converter hub and oil pump seal lip with transmission fluid.
- (2) Place torque converter in position on transmission.

CAUTION: Do not damage oil pump seal or bushing while inserting torque converter into the front of the transmission.

- (3) Align torque converter to oil pump seal opening.
- (4) Insert torque converter hub into oil pump.
- (5) While pushing torque converter inward, rotate converter until converter is fully seated in the oil pump gears.
- (6) Check converter seating with a scale and straightedge (Fig. 17). Surface of converter lugs should be 1/2 in. to rear of straightedge when converter is fully seated.
- (7) If necessary, temporarily secure converter with C-clamp attached to the converter housing.
- (8) Install the transmission in the vehicle.
- (9) Fill the transmission with the recommended fluid.

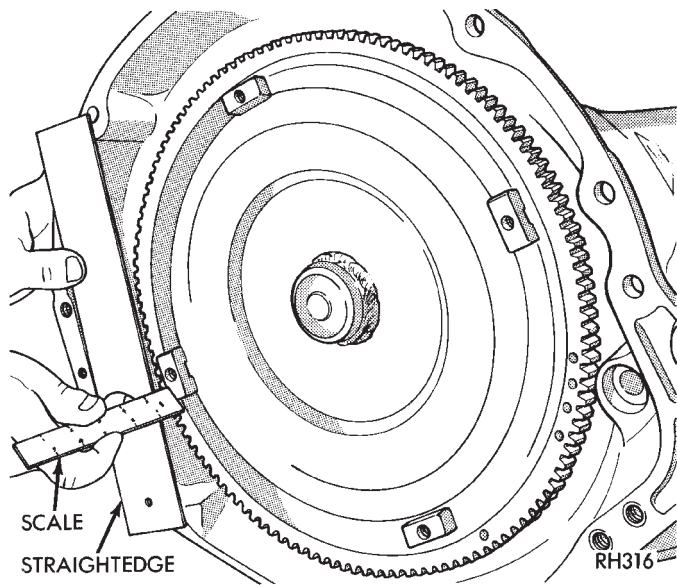


Fig. 17 Checking Torque Converter Seating

YOKE SEAL REPLACEMENT

REMOVAL

- (1) Raise vehicle.
- (2) Mark propeller shaft and axle yoke for alignment reference.
- (3) Disconnect and remove propeller shaft.
- (4) Remove old seal with Seal Remover C-3985-B (Fig. 18) from overdrive housing.

INSTALLATION

- (1) Place seal in position on overdrive housing.
- (2) Drive seal into overdrive housing with Seal Installer C-3995-A (Fig. 19).
- (3) Carefully guide propeller shaft slip yoke into housing and onto output shaft splines. Align marks made at removal and connect propeller shaft to rear axle pinion yoke.

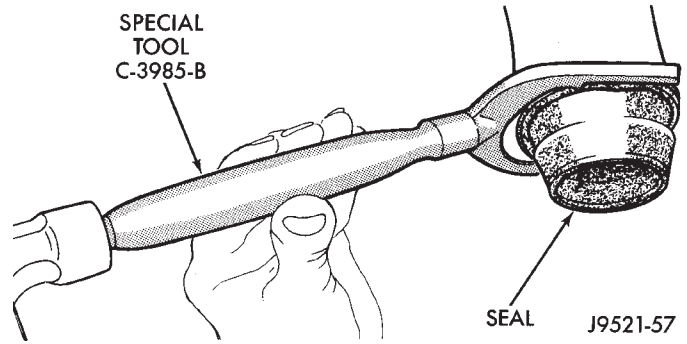


Fig. 18 Removing Overdrive Housing Yoke Seal

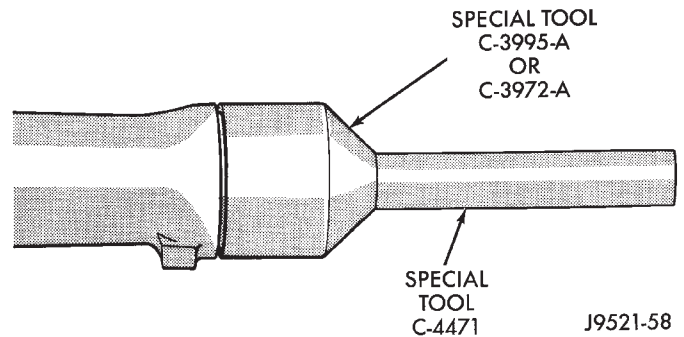


Fig. 19 Installing Overdrive Housing Yoke Seal

SPEEDOMETER ADAPTER

Rear axle gear ratio and tire size determine speedometer pinion requirements.

REMOVAL

- (1) Raise vehicle.
- (2) Disconnect wires from vehicle speed sensor.
- (3) Remove adapter clamp and screw (Fig. 20).
- (4) Remove speed sensor and speedometer adapter as assembly.
- (5) Remove speed sensor retaining screw and remove sensor from adapter.
- (6) Remove speedometer pinion from adapter.
- (7) Inspect sensor and adapter O-rings (Fig. 20). Remove and discard O-rings if worn or damaged.
- (8) Inspect terminal pins in speed sensor. Clean pins with Mopar® electrical spray cleaner if dirty or oxidized. Replace sensor if faulty, or pins are loose, severely corroded, or damaged.

REMOVAL AND INSTALLATION (Continued)

ITEM	TORQUE
A	2-3 N•m (15-27 in. lbs.)
B	10-12 N•m (90-110 in. lbs.)

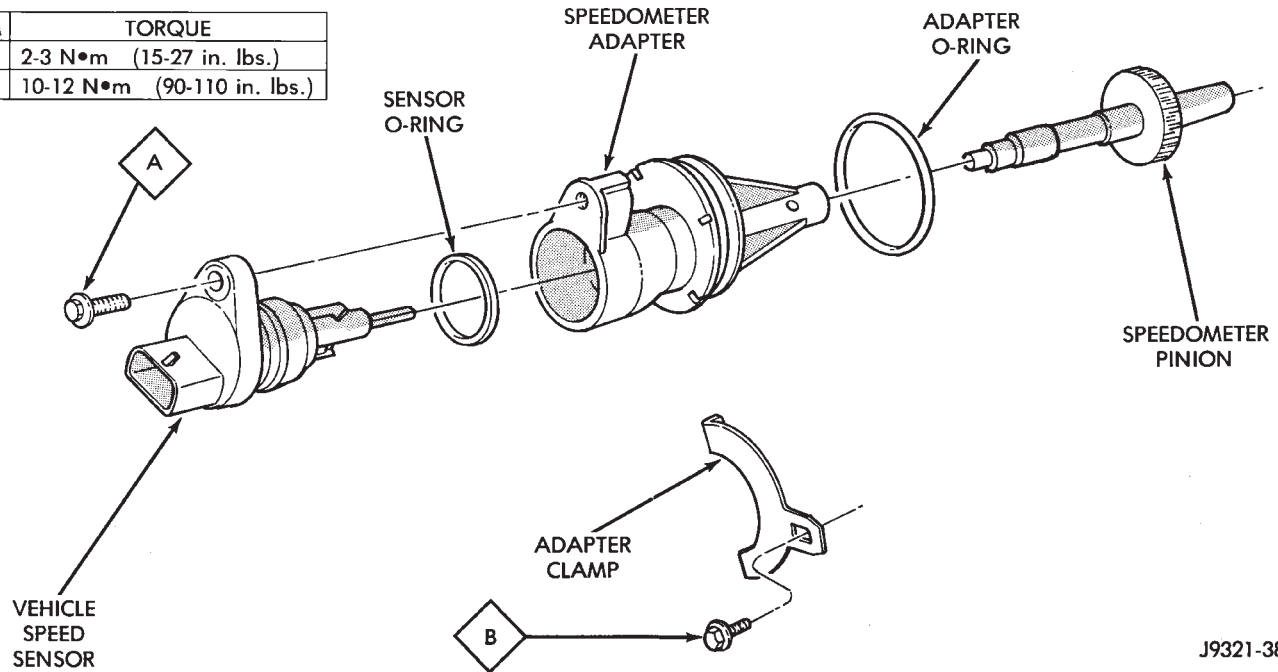


Fig. 20 Speedometer Pinion Adapter Components

INSTALLATION

(1) Thoroughly clean adapter flange and adapter mounting surface in housing. Surfaces must be clean for proper adapter alignment and speedometer operation.

(2) Install new O-rings on speed sensor and speedometer adapter if necessary (Fig. 20).

(3) Lubricate sensor and adapter O-rings with transmission fluid.

(4) Install vehicle speed sensor in speedometer adapter. Tighten sensor attaching screw to 2-3 N•m (15-27 in. lbs.) torque.

(5) Install speedometer pinion in adapter.

(6) Count number of teeth on speedometer pinion. Do this before installing assembly in housing. Then lubricate pinion teeth with transmission fluid.

(7) Note index numbers on adapter body (Fig. 21). These numbers will correspond to number of teeth on pinion.

(8) Install speedometer assembly in housing.

(9) Rotate adapter until required range numbers are at 6 o'clock position. Be sure range index numbers correspond to number of teeth on pinion gear.

(10) Install speedometer adapter clamp and retaining screw. Tighten clamp screw to 10-12 N•m (90-110 in. lbs.) torque.

(11) Connect wires to vehicle speed sensor.

(12) Lower vehicle and top off transmission fluid level, if necessary.

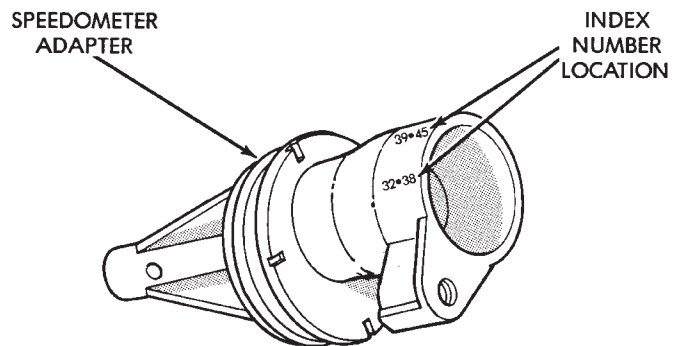


Fig. 21 Index Numbers On Speedometer Pinion Adapter

PARK/NEUTRAL POSITION SWITCH

REMOVAL

(1) Raise vehicle and position drain pan under switch.

(2) Disconnect switch wires.

(3) Remove switch from case.

INSTALLATION

(1) Move shift lever to Park and Neutral positions. Verify that switch operating lever fingers are centered in switch opening in case (Fig. 22).

(2) Install new seal on switch and install switch in case. Tighten switch to 34 N•m (25 ft. lbs.) torque.

REMOVAL AND INSTALLATION (Continued)

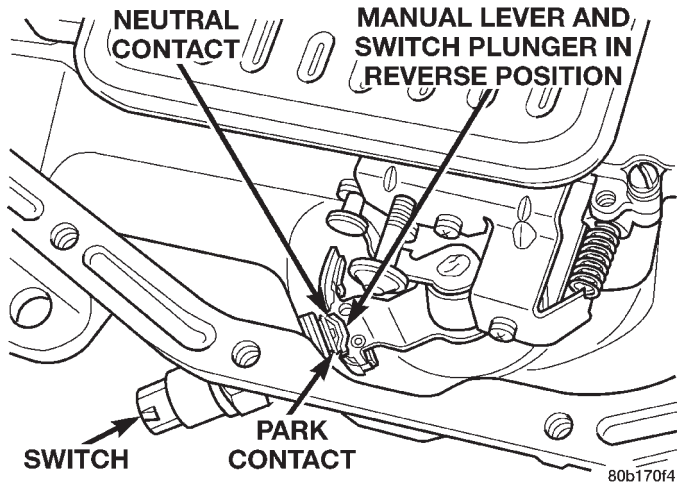


Fig. 22 Park/Neutral Position Switch

- (3) Test continuity of new switch with 12V test lamp.
- (4) Connect switch wires and lower vehicle.
- (5) Top off transmission fluid level.

GEARSHIFT CABLE

REMOVAL

- (1) Shift transmission into Park.
- (2) Remove shift lever bezel and necessary console parts for access to shift lever assembly.
- (3) Disconnect cable at shift lever and feed cable through dash panel opening to underside of vehicle.
- (4) Raise vehicle.
- (5) Disengage cable eyelet at transmission shift lever and pull cable adjuster out of mounting bracket. Then remove old cable from vehicle.

INSTALLATION

- (1) Route cable through hole in dash panel. Fully seat cable grommet into dash panel.
- (2) Place the auto transmission manual shift control lever in "Park" detent (rear-most) position and rotate prop shaft to ensure transmission is in park.
- (3) Connect shift cable to shifter mechanism by snapping cable retaining ears into shifter bracket and press cable end fitting onto lever ball stud.
- (4) Place the floor shifter lever in park position. Ensure that the pawl is seated within the confines of the adjustment gauge clip.
- (5) Snap the cable into the transmission bracket so the retaining ears are engaged and connect cable end fitting onto the manual control lever ball stud.
- (6) Lock shift cable into position by pushing upward on the adjusting lock button.
- (7) Remove and discard the shift cable adjustment gauge clip from the park gate of the shifter.

BRAKE TRANSMISSION SHIFT INTERLOCK

REMOVAL

- (1) Lower the steering column.
- (2) Remove two screws retaining the interlock mechanism to the column (Fig. 23). Unsnap the mechanism from column.

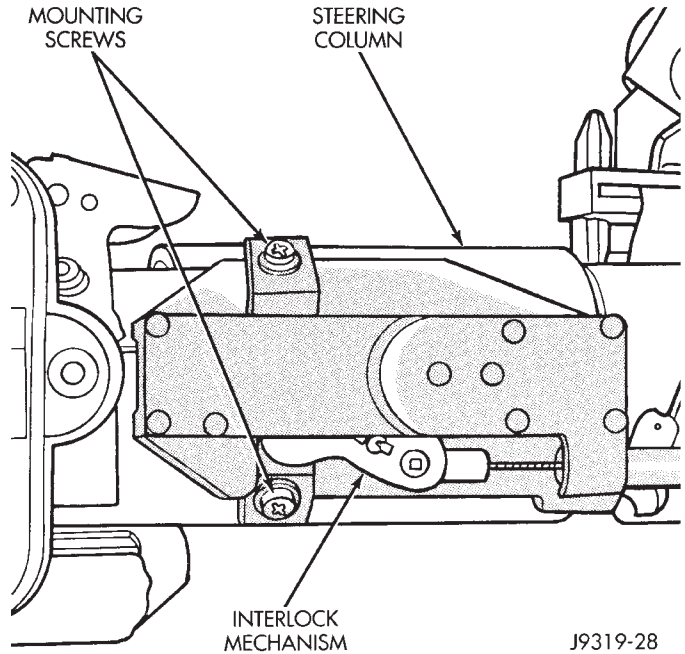


Fig. 23 Interlock Mechanism on Column

- (3) Remove the center console and related trim. Refer to Group 23, Body, for proper procedures.
- (4) Disconnect and remove the cable from the shift bracket.
- (5) Remove the wire connector at the solenoid on the cable
- (6) Remove the accelerator pedal (the cable routes under the pedal). Refer to Group 14, Fuel Systems, for proper procedures.
- (7) Release the cable from the accelerator pedal clip.
- (8) Remove the carpet as necessary to remove the cable.

INSTALLATION

NOTE: The gearshift cable must be secured into position and properly adjusted before the installation of the Brake Transmission Interlock Cable (BTSI).

- (1) Snap the cable base assembly into the large square opening in the steering column.
- (2) Secure the plastic base with two (2) self tapping screws (tighten upper screw first).

REMOVAL AND INSTALLATION (Continued)

- (3) Snap BTSI cable solenoid tie strap into hole in steering column tube.
- (4) Route BTSI cable into two clips on carpet pad.
- (5) Snap electrical connector from brake light switch into BTSI cable solenoid housing.
- (6) Snap BTSI cable adjuster ears into floor shifter bracket and attach cable end fitting onto floor shifter interlock lever stud.
- (7) Remove shipping pin from plastic base. Then place floor shifter in Park position.
- (8) Place the ignition key cylinder in the ACCESSORY position.
- (9) Push the cable adjuster lock clamp downward to lock it.
- (10) Remove and discard the BTSI cable nail head lockpin at steering column.
- (11) Install the center console and related trim. Refer to Group 23, Body, for proper procedures.
- (12) Test the BTSI cable operation.

GOVERNOR SOLENOID AND PRESSURE SENSOR**REMOVAL**

- (1) Hoist and support vehicle on safety stands.
- (2) Remove transmission fluid pan and filter.
- (3) Disengage wire connectors from pressure sensor and solenoid (Fig. 24).
- (4) Remove screws holding pressure solenoid retainer to governor body.
- (5) Separate solenoid retainer from governor (Fig. 25).
- (6) Pull solenoid from governor body (Fig. 26).
- (7) Remove bolts holding governor body to valve body.
- (8) Separate governor body from valve body (Fig. 27).
- (9) Remove governor body gasket.
- (10) Remove retainer holding pressure sensor to governor body.
- (11) Pull pressure sensor from governor body (Fig. 28).

INSTALLATION

Before installing the pressure sensor and solenoid in the governor body, replace O-ring seals, clean the gasket surfaces and replace gasket.

- (1) Lubricate O-ring on pressure sensor with transmission fluid.
- (2) Align pressure sensor to bore in governor body (Fig. 28).
- (3) Push pressure sensor into governor body.
- (4) Install retainer to hold pressure sensor to governor body.
- (5) Place gasket in position on back of governor body (Fig. 27).
- (6) Place governor body in position on valve body.

- (7) Install bolts to hold governor body to valve body.
- (8) Lubricate O-ring, on pressure solenoid, with transmission fluid.
- (9) Align pressure solenoid to bore in governor body (Fig. 26).
- (10) Push solenoid into governor body.
- (11) Place solenoid retainer in position on governor (Fig. 25).
- (12) Install screws to hold pressure solenoid retainer to governor body.
- (13) Engage wire connectors into pressure sensor and solenoid (Fig. 24).
- (14) Install transmission fluid pan and (new) filter.
- (15) Lower vehicle and road test to verify repair.

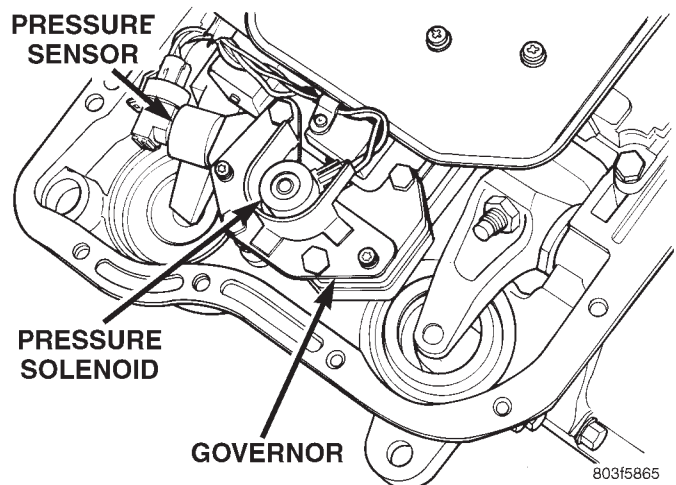


Fig. 24 Governor Solenoid And Pressure Sensor

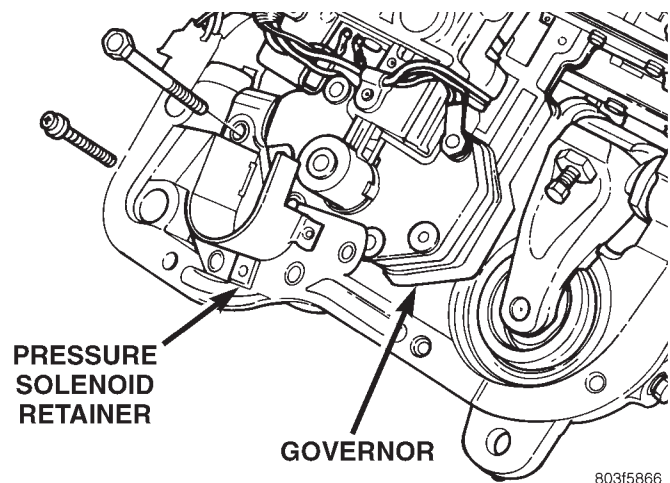


Fig. 25 Pressure Solenoid Retainer

VALVE BODY

The valve body can be removed for service without having to remove the transmission assembly.

The valve body can be disassembled for cleaning and inspection of the individual components. Refer to

REMOVAL AND INSTALLATION (Continued)

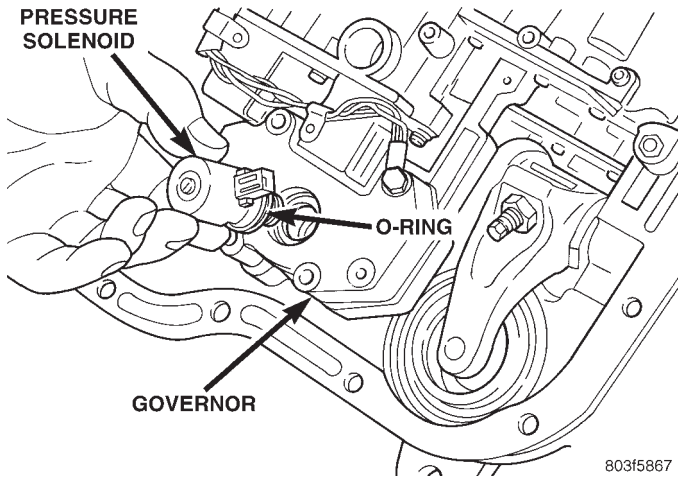


Fig. 26 Pressure Solenoid and O-ring

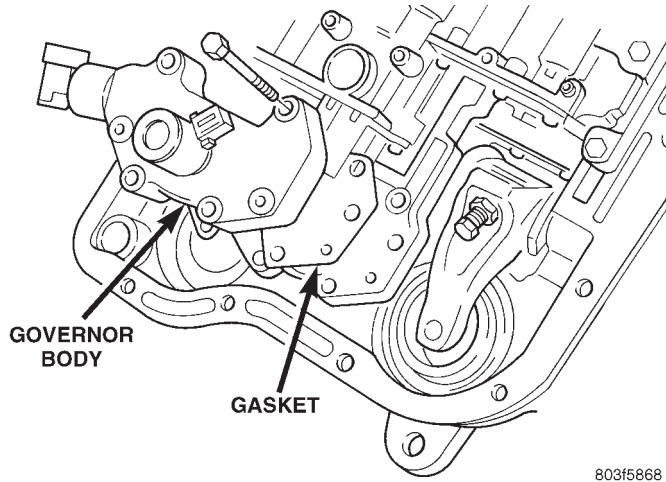


Fig. 27 Governor Body and Gasket

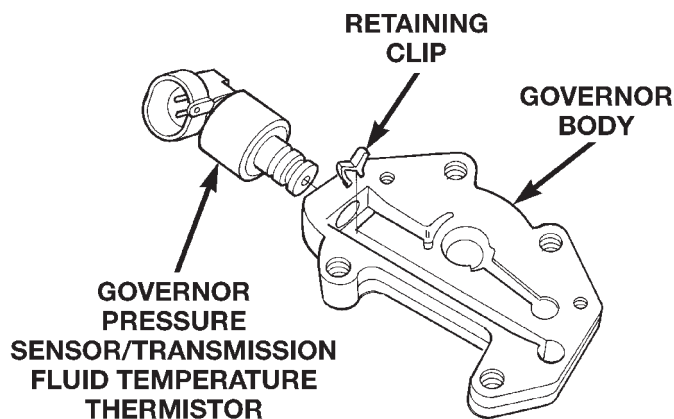


Fig. 28 Pressure Sensor and Retainer

Disassembly and Assembly section for proper procedures.

- The only replaceable valve body components are:
- Manual lever.

- Manual lever washer, seal, E-clip, and shaft seal.
- Manual lever detent ball.
- Throttle lever.
- Fluid filter.
- Pressure adjusting screw bracket.
- Governor pressure solenoid.
- Governor pressure sensor.
- Converter clutch/overdrive solenoid assembly and harness (includes sump temperature thermistor).
- Governor housing gasket.
- Solenoid case connector O-rings.

The remaining valve body components are serviced only as part of a complete valve body assembly.

REMOVAL

- (1) Shift transmission into NEUTRAL.
- (2) Raise vehicle.
- (3) Remove gearshift and throttle levers from shaft of valve body manual lever.
- (4) Disconnect wires at solenoid case connector (Fig. 29).
- (5) Position drain pan under transmission oil pan.
- (6) Remove transmission oil pan and gasket.
- (7) Remove fluid filter from valve body.
- (8) Remove bolts attaching valve body to transmission case.
- (9) Lower valve body enough to remove accumulator piston and springs.
- (10) Work manual lever shaft and electrical connector out of transmission case.
- (11) Lower valve body, rotate valve body away from case, pull park rod out of sprag, and remove valve body (Fig. 30).

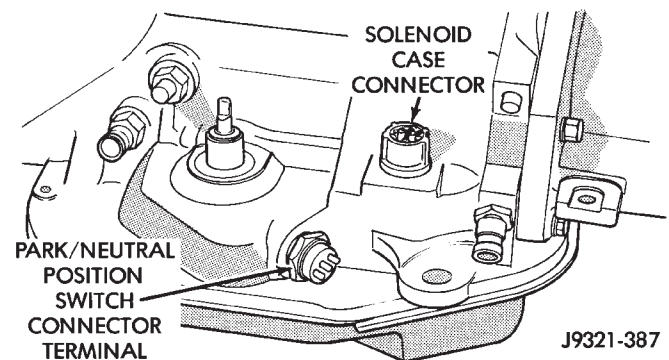


Fig. 29 Transmission Case Connector

INSTALLATION

- (1) Check condition of O-ring seals on valve body harness connector (Fig. 31). Replace seals on connector body if cut or worn.
- (2) Check condition of manual lever shaft seal in transmission case. Replace seal if lip is cut or worn. Install new seal with 15/16 deep well socket (Fig. 32).
- (3) Check condition of seals on accumulator piston (Fig. 33). Install new piston seals, if necessary.

REMOVAL AND INSTALLATION (Continued)

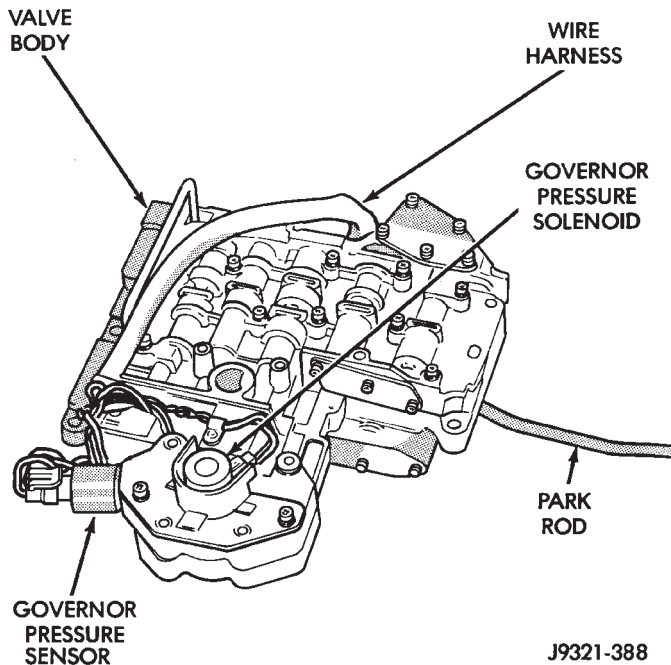


Fig. 30 Valve Body

(4) Place valve body manual lever in low (1 position) so ball on park lock rod will be easier to install in sprag.

(5) Lubricate shaft of manual lever with petroleum jelly. This will ease inserting shaft through seal in case.

(6) Lubricate seal rings on valve body harness connector with petroleum jelly.

(7) Position valve body in case and work end of park lock rod into and through pawl sprag. Turn propeller shaft to align sprag and park lock teeth if necessary. The rod will click as it enters pawl. Move rod to check engagement.

CAUTION: It is possible for the park rod to displace into a cavity just above the pawl sprag during installation. Make sure the rod is actually engaged in the pawl and has not displaced into this cavity.

(8) Install accumulator springs and piston into case. Then swing valve body over piston and outer spring to hold it in place.

(9) Align accumulator piston and outer spring, manual lever shaft and electrical connector in case.

(10) Then seat valve body in case and install one or two bolts to hold valve body in place.

(11) Tighten valve body bolts alternately and evenly to 11 N·m (100 in. lbs.) torque.

(12) Install new fluid filter on valve body. Tighten filter screws to 4 N·m (35 in. lbs.) torque.

(13) Install throttle and gearshift levers on valve body manual lever shaft.

(14) Check and adjust front and rear bands if necessary.

(15) Connect solenoid case connector wires.

(16) Install oil pan and new gasket. Tighten pan bolts to 17 N·m (13 ft. lbs.) torque.

(17) Lower vehicle and fill transmission with Mopar® ATF Plus 3, type 7176 fluid.

(18) Check and adjust gearshift and throttle valve cables, if necessary.

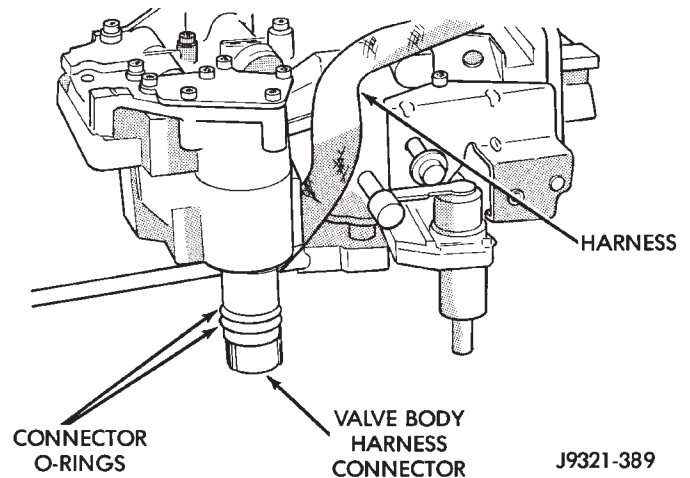


Fig. 31 Valve Body Harness Connector O-Ring Seal

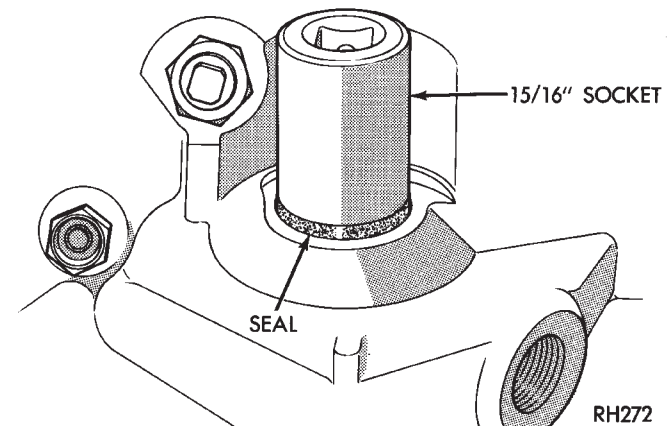


Fig. 32 Manual Lever Shaft Seal

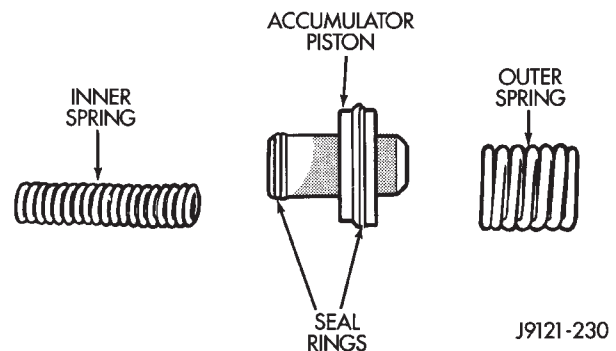


Fig. 33 Accumulator Piston Components

REMOVAL AND INSTALLATION (Continued)

OVERDRIVE UNIT

REMOVAL

- (1) Shift transmission into Park.
- (2) Raise vehicle.
- (3) Mark propeller shaft universal joint(s) and axle pinion yoke for alignment reference at installation.
- (4) Disconnect and remove propeller shaft(s).
- (5) Remove transmission oil pan, remove gasket, drain oil and reinstall pan.
- (6) If overdrive unit had malfunctioned, or if fluid is contaminated, remove entire transmission. If diagnosis indicated overdrive problems only, remove just the overdrive unit.
- (7) Support transmission with transmission jack.
- (8) Remove vehicle speed sensor and speedometer adapter, if necessary.
- (9) Remove bolts attaching overdrive unit to transmission (Fig. 34).

CAUTION: Support the overdrive unit with a jack before moving it rearward. This is necessary to prevent damaging the intermediate shaft. Do not allow the shaft to support the entire weight of the overdrive unit.

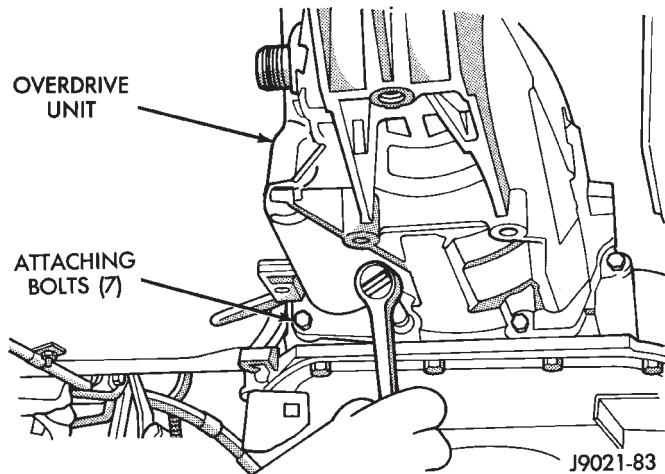


Fig. 34 Overdrive Unit Bolts

(10) Carefully work overdrive unit off intermediate shaft. Do not tilt unit during removal. Keep it as level as possible.

(11) If overdrive unit does not require service, immediately insert Alignment Tool 6227-2 in splines of planetary gear and overrunning clutch to prevent splines from rotating out of alignment. If misalignment occurs, overdrive unit will have to be disassembled in order to realign splines.

(12) Remove and retain overdrive piston thrust bearing. Bearing may remain on piston or in clutch hub during removal.

(13) Position drain pan on workbench.

(14) Place overdrive unit over drain pan. Tilt unit to drain residual fluid from case.

(15) Examine fluid for clutch material or metal fragments. If fluid contains these items, overhaul will be necessary.

(16) If overdrive unit does not require any service, leave alignment tool in position. Tool will prevent accidental misalignment of planetary gear and overrunning clutch splines.

INSTALLATION

(1) Be sure overdrive unit Alignment Tool 6227-2 is fully seated before moving unit. If tool is not seated and gear splines rotate out of alignment, overdrive unit will have to be disassembled in order to realign splines.

(2) If overdrive piston retainer was not removed during service and original case gasket is no longer reusable, prepare new gasket by trimming it.

(3) Cut out old case gasket around piston retainer with razor knife (Fig. 35).

(4) Use old gasket as template and trim new gasket to fit.

(5) Position new gasket over piston retainer and on transmission case. Use petroleum jelly to hold gasket in place if necessary. Do not use any type of sealer to secure gasket. Use petroleum jelly only.

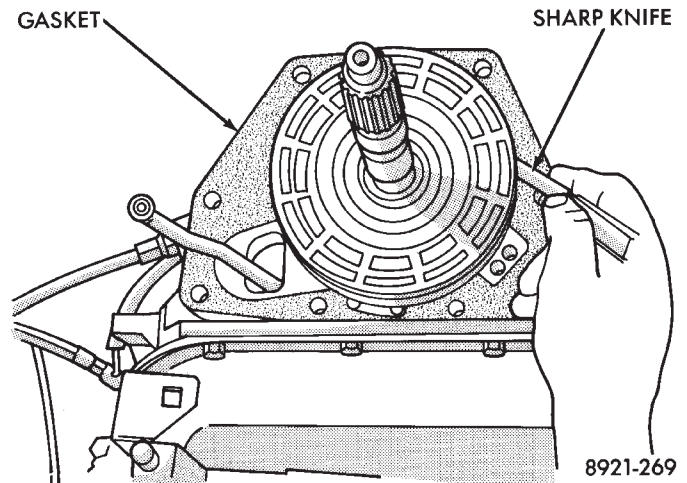


Fig. 35 Trimming Overdrive Case Gasket

(6) Install selective spacer on intermediate shaft, if removed. Spacer goes in groove just rearward of shaft rear splines (Fig. 36).

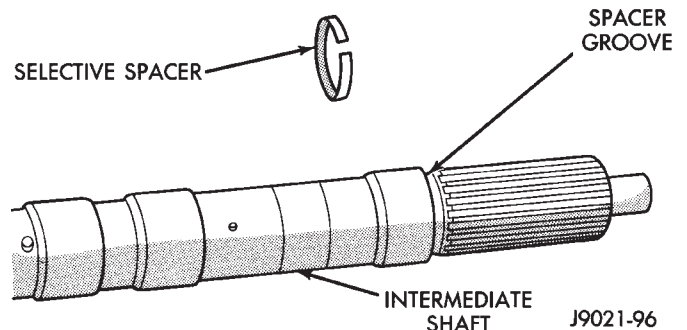


Fig. 36 Intermediate Shaft Selective Spacer Location

REMOVAL AND INSTALLATION (Continued)

(7) Install thrust bearing in overdrive unit sliding hub. Use petroleum jelly to hold bearing in position.

CAUTION: Be sure the shoulder on the inside diameter of the bearing is facing forward.

(8) Verify that splines in overdrive planetary gear and overrunning clutch hub are aligned with Alignment Tool 6227-2. Overdrive unit cannot be installed if splines are not aligned. If splines have rotated out of alignment, unit will have to be disassembled to realign splines.

(9) Carefully slide Alignment Tool 6227-2 out of overdrive planetary gear and overrunning clutch splines.

(10) Raise overdrive unit and carefully slide it straight onto intermediate shaft. Insert park rod into park lock reaction plug at same time. Avoid tilting overdrive during installation as this could cause planetary gear and overrunning clutch splines to rotate out of alignment. If this occurs, it will be necessary to remove and disassemble overdrive unit to realign splines.

(11) Work overdrive unit forward on intermediate shaft until seated against transmission case.

(12) Install bolts attaching overdrive unit to transmission unit. Tighten bolts in diagonal pattern to 34 N·m (25 ft-lbs).

(13) Install speed sensor and speedometer adapter. Be sure to index adapter.

(14) Connect speed sensor and overdrive wires.

(15) Align and install propeller shaft.

OVERDRIVE HOUSING BUSHING**REMOVAL**

- (1) Remove overdrive housing yoke seal.
- (2) Insert Remover 6957 into overdrive housing. Tighten tool to bushing and remove bushing (Fig. 37).

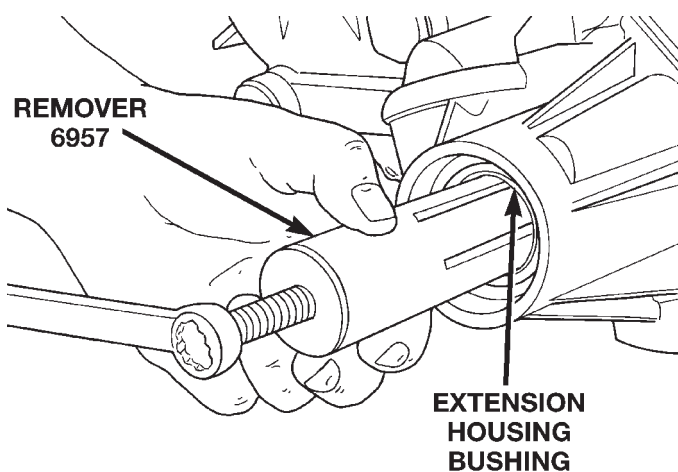


Fig. 37 Bushing Removal—Typical

80a11095

INSTALLATION

- (1) Align bushing oil hole with oil slot in overdrive housing.
- (2) Tap bushing into place with Installer 6951 and Handle C-4171.
- (3) Install new oil seal in housing using Seal Installer C-3995-A (Fig. 38).

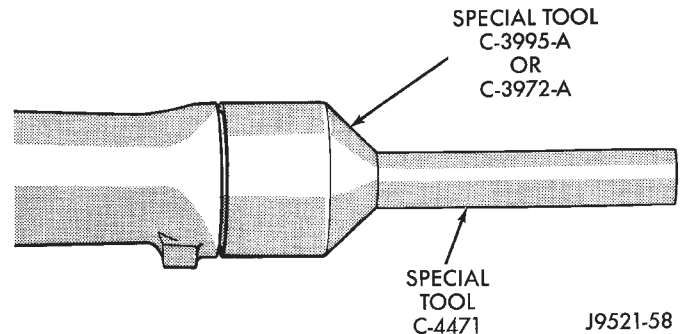


Fig. 38 Overdrive Housing Seal Installation

OUTPUT SHAFT REAR BEARING**REMOVAL**

- (1) Remove overdrive unit from the vehicle.
- (2) Remove overdrive geartrain from housing.
- (3) Remove snap ring holding output shaft rear bearing into overdrive housing (Fig. 39).
- (4) Using a suitable driver inserted through the rear end of housing, drive bearing from housing.

INSTALLATION

- (1) Place replacement bearing in housing.
- (2) Using a suitable driver, drive bearing into housing until the snap ring groove is visible.
- (3) Install snap ring to hold bearing into housing (Fig. 39).
- (4) Install overdrive geartrain into housing.
- (5) Install overdrive unit in vehicle.

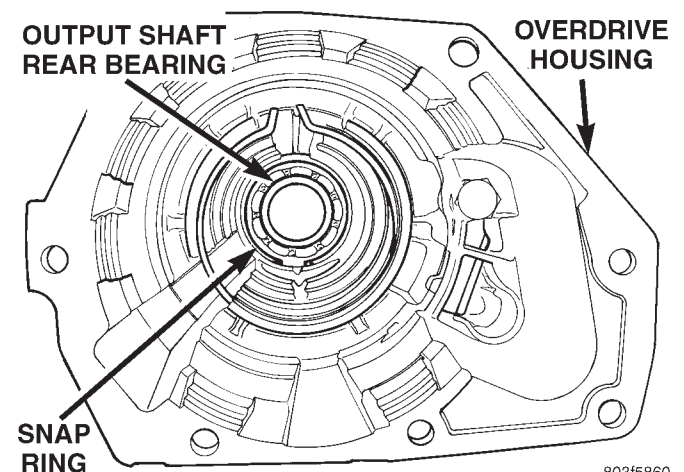


Fig. 39 Output Shaft Rear Bearing

803f5860

REMOVAL AND INSTALLATION (Continued)

OUTPUT SHAFT FRONT BEARING

REMOVAL

- (1) Remove overdrive unit from the vehicle.
- (2) Remove overdrive geartrain from housing.
- (3) Remove snap ring holding output shaft front bearing to overdrive geartrain. (Fig. 40).
- (4) Pull bearing from output shaft.

INSTALLATION

- (1) Place replacement bearing in position on geartrain with locating retainer groove toward the rear.
- (2) Push bearing onto shaft until the snap ring groove is visible.
- (3) Install snap ring to hold bearing onto output shaft (Fig. 40).
- (4) Install overdrive geartrain into housing.
- (5) Install overdrive unit in vehicle.

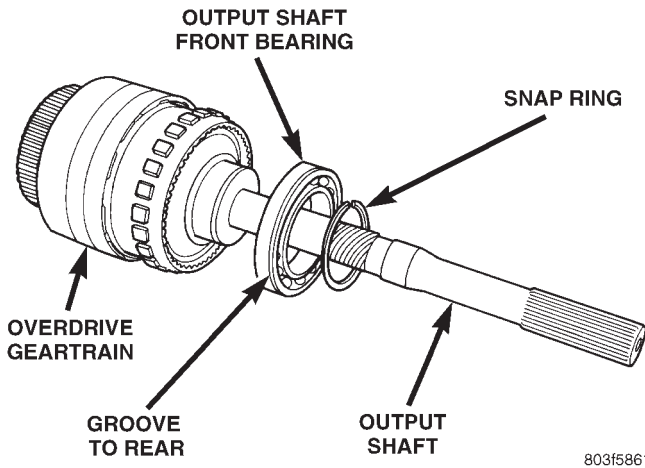


Fig. 40 Output Shaft Front Bearing

DISASSEMBLY AND ASSEMBLY

VALVE BODY

Remove the valve body from the transmission, refer to Removal and Installation procedures section in this group.

DISASSEMBLY

CAUTION: Do not clamp any valve body component in a vise. This practice can damage the component resulting in unsatisfactory operation after assembly and installation. Do not use pliers to remove any of the valves, plugs or springs and do not force any of the components out or into place. The valves and valve body housings will be damaged if force is used. Tag or mark the valve body springs for reference as they are removed. Do not allow them to become intermixed.

- (1) Remove fluid filter.
- (2) Disconnect wires from governor pressure sensor and solenoid.
- (3) Remove screws attaching governor body and retainer plate to transfer plate.
- (4) Remove retainer plate, governor body and gasket from transfer plate.
- (5) Disconnect wires from governor pressure sensor, if not done previously.
- (6) Remove governor pressure sensor from governor body. Sensor is retained in body with M-shaped spring clip. Remove clip with small pointed tool and slide sensor out of body.
- (7) Remove governor pressure solenoid by pulling it straight out of bore in governor body. Remove and discard solenoid O-rings if worn, cut, or torn.
- (8) Remove small shoulder bolt that secures solenoid harness case connector to 3-4 accumulator housing (Fig. 41). **Retain shoulder bolt. Either tape it to harness or thread it back into accumulator housing after connector removal.**
- (9) Unhook overdrive/converter solenoid harness from 3-4 accumulator cover plate (Fig. 42).
- (10) Turn valve body over and remove screws that attach overdrive/converter solenoid assembly to valve body (Fig. 43).
- (11) Remove solenoid and harness assembly from valve body (Fig. 44).
- (12) Remove boost valve cover (Fig. 45).
- (13) Remove boost valve retainer, valve spring and boost valve (Fig. 46).

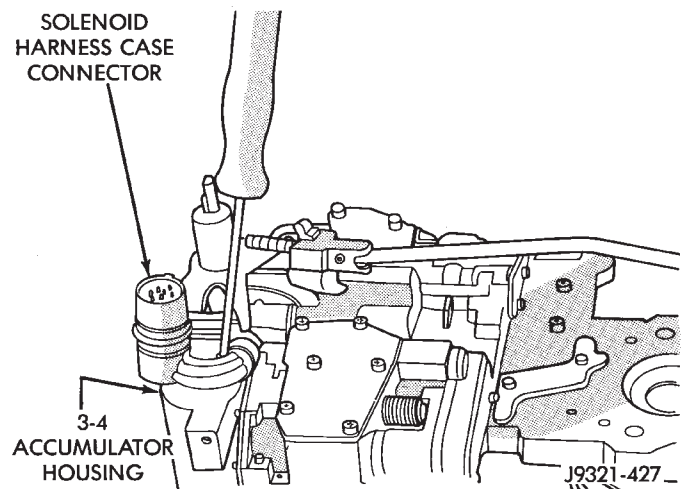


Fig. 41 Solenoid Harness Case Connector Shoulder Bolt

DISASSEMBLY AND ASSEMBLY (Continued)

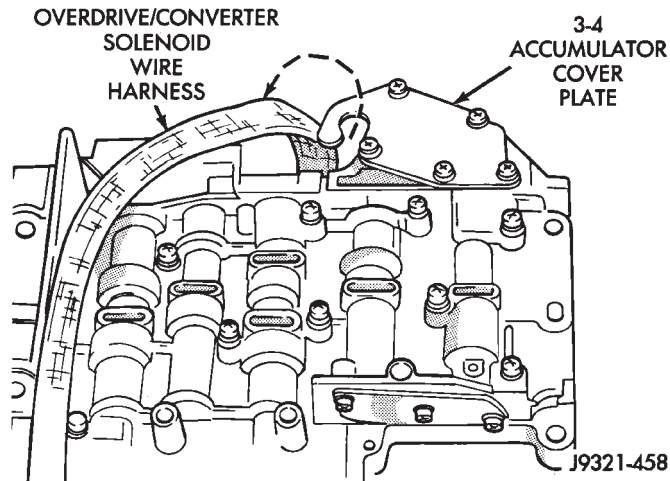


Fig. 42 Unhooking Solenoid Harness From Accumulator Cover Plate

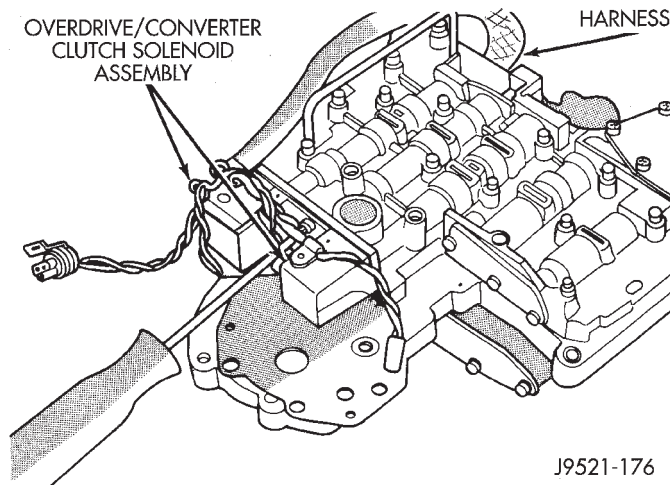


Fig. 43 Solenoid Assembly Screws

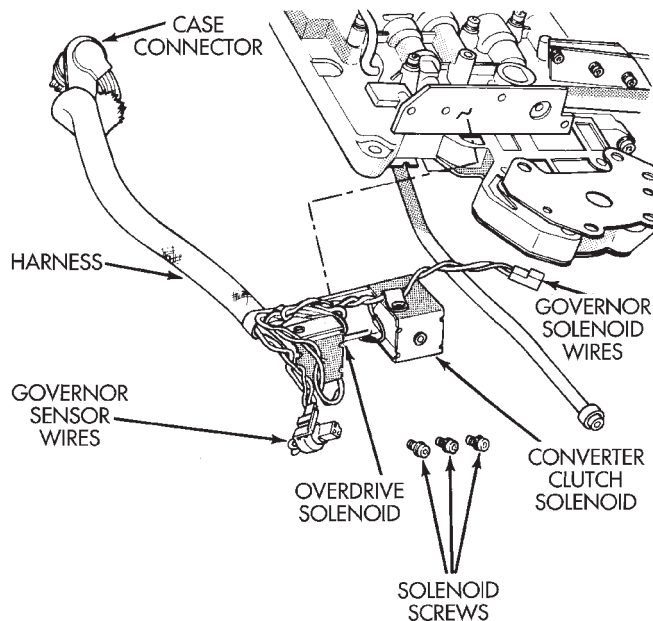


Fig. 44 Solenoid Assembly

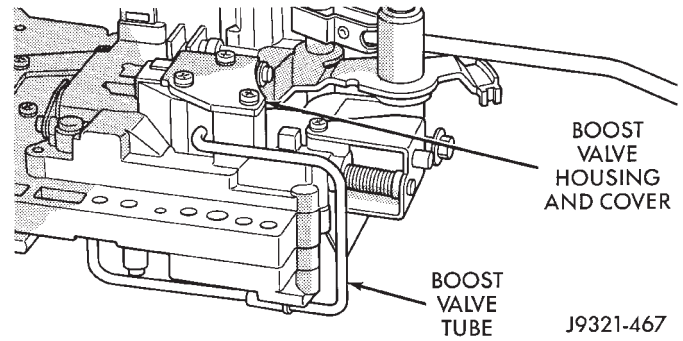


Fig. 45 Boost Valve Cover Location

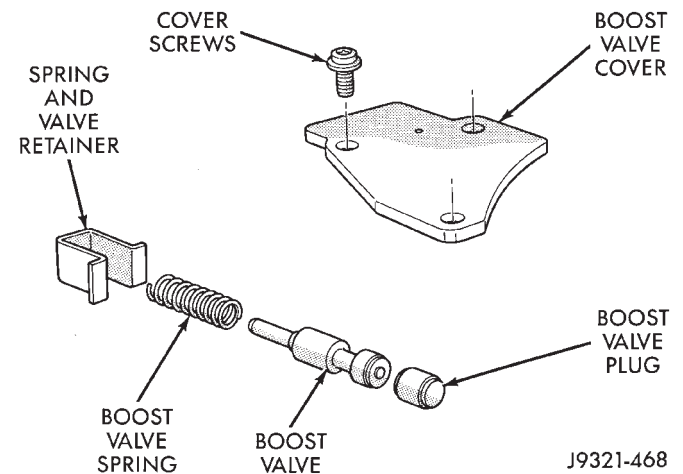


Fig. 46 Boost Valve Components

(14) Secure detent ball and spring with Retainer Tool 6583 (Fig. 47).

(15) Remove park rod E-clip and separate rod from manual lever (Fig. 48).

(16) Remove E-clip and washer that retains throttle lever shaft in manual lever (Fig. 49).

(17) Remove manual lever and throttle lever (Fig. 50). Rotate and lift manual lever off valve body and throttle lever shaft. Then slide throttle lever out of valve body.

(18) Position pencil magnet next to detent housing to catch detent ball and spring. Then carefully remove Retainer Tool 6583 and remove detent ball and spring (Fig. 51).

(19) Remove screws attaching pressure adjusting screw bracket to valve body and transfer plate (Fig. 52). Hold bracket firmly against spring tension while removing last screw.

DISASSEMBLY AND ASSEMBLY (Continued)

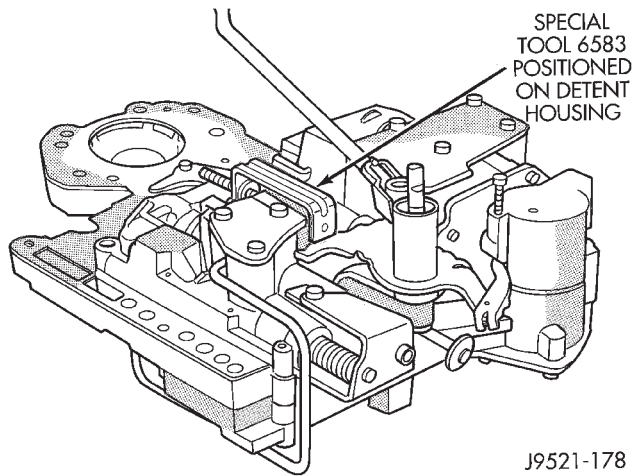


Fig. 47 Detent Ball And Spring

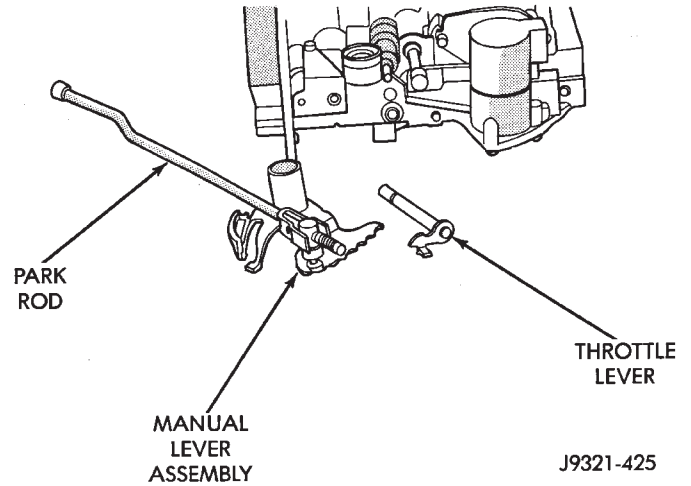


Fig. 50 Manual And Throttle Lever

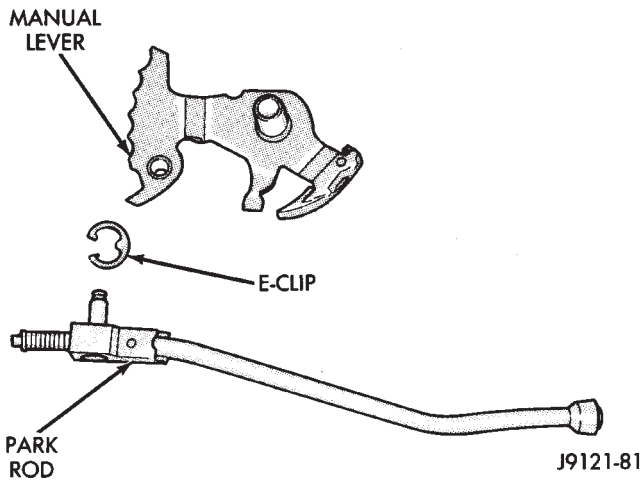


Fig. 48 Park Rod

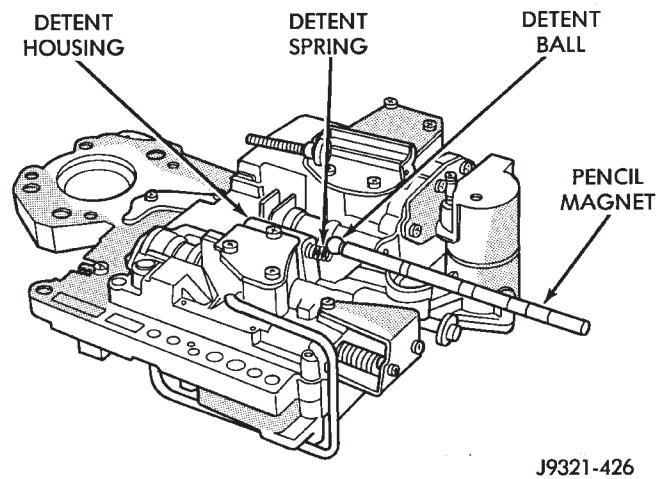


Fig. 51 Detent Ball And Spring

(20) Remove adjusting screw bracket, line pressure adjusting screw, pressure regulator valve spring and switch valve spring (Fig. 53). **Do not remove throttle pressure adjusting screw from bracket and do not disturb setting of either adjusting screw during removal.**

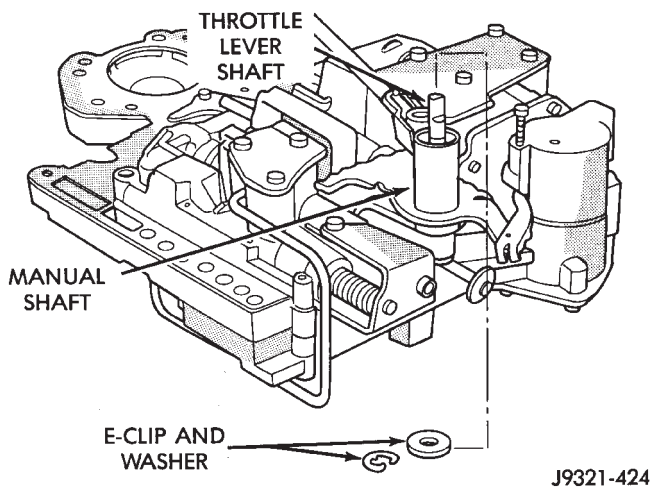


Fig. 49 Throttle Lever E-Clip And Washer

DISASSEMBLY AND ASSEMBLY (Continued)

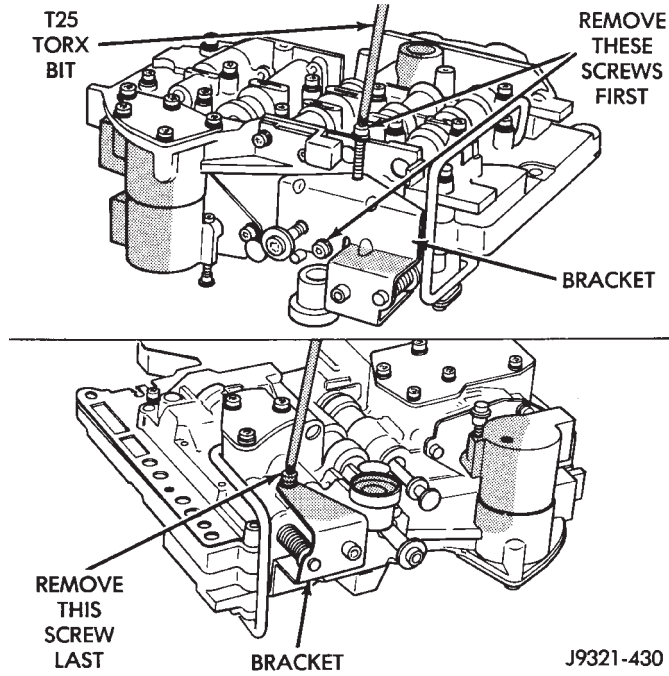


Fig. 52 Adjusting Screw Bracket Fastener

(21) Turn upper housing over and remove switch valve, regulator valve and spring, and manual valve (Fig. 54).

(22) Remove kickdown detent, kickdown valve, and throttle valve and spring (Fig. 54).

(23) Loosen left-side 3-4 accumulator housing attaching screw about 2-3 threads. Then remove center and right-side housing attaching screws (Fig. 55).

(24) Carefully rotate 3-4 accumulator housing upward and remove 3-4 shift valve spring and converter clutch valve plug and spring (Fig. 56).

(25) Remove left-side screw and remove 3-4 accumulator housing from valve body (Fig. 57).

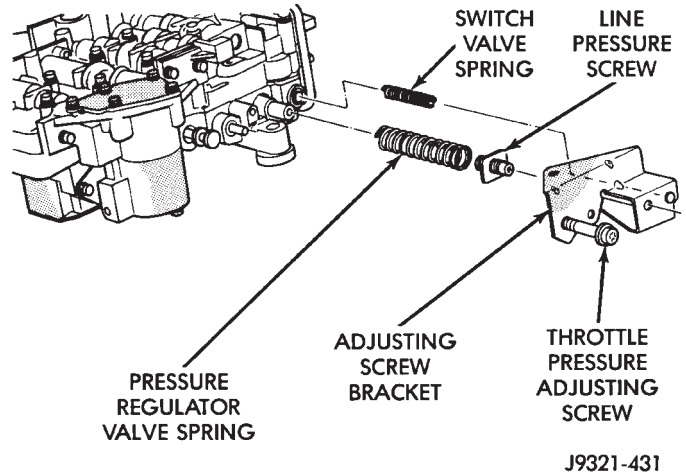


Fig. 53 Adjusting Screw Bracket And Spring

(26) Bend back tabs on boost valve tube brace (Fig. 58).

(27) Remove boost valve connecting tube (Fig. 59). Disengage tube from upper housing port first. Then rock opposite end of tube back and forth to work it out of lower housing.

CAUTION: Do not use tools to loosen or pry the connecting tube out of the valve body housings. Loosen and remove the tube by hand only.

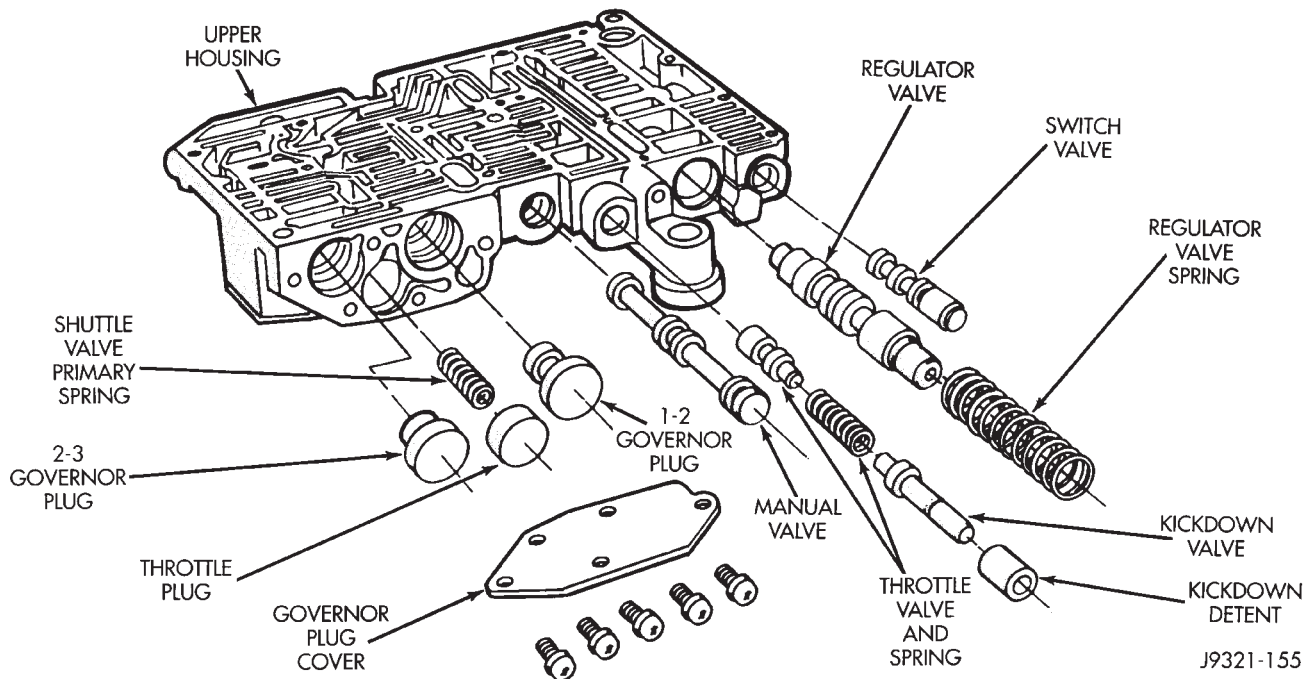


Fig. 54 Upper Housing Control Valve Locations

DISASSEMBLY AND ASSEMBLY (Continued)

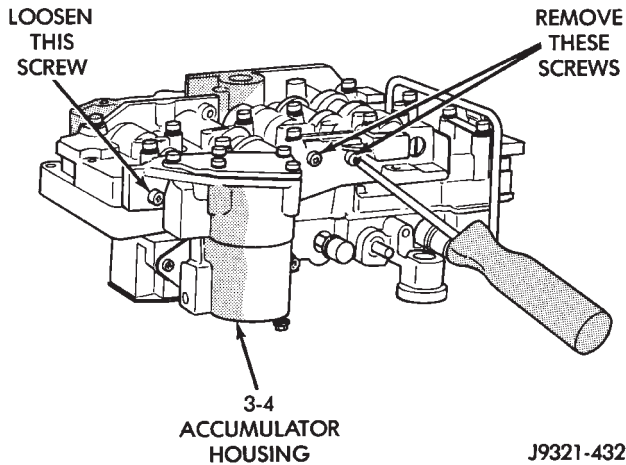


Fig. 55 Accumulator Housing Screw Locations

J9321-432

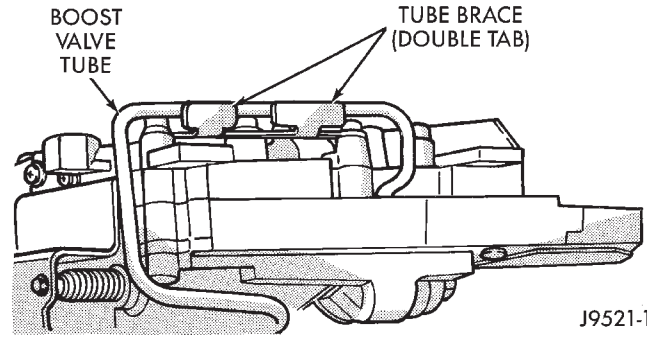


Fig. 58 Boost Valve Tube Brace

J9521-101

(28) Turn valve body over so lower housing is facing upward (Fig. 60). In this position, the two check balls in upper housing will remain in place and not fall out when lower housing and separator plate are removed.

(29) Remove screws attaching valve body lower housing to upper housing and transfer plate (Fig.

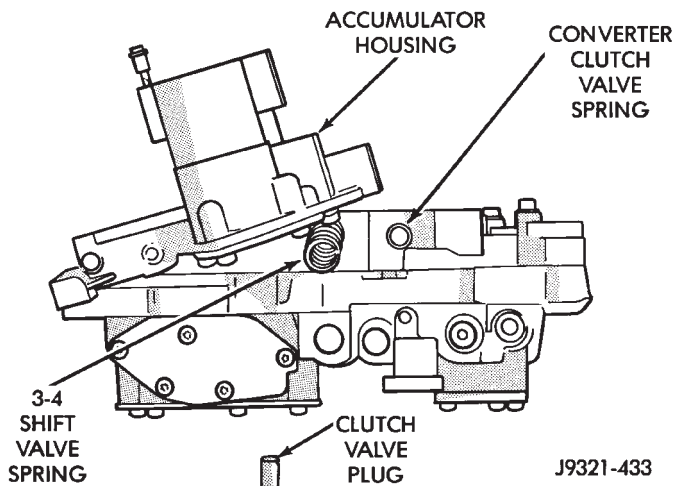


Fig. 56 3-4 Shift And Converter Clutch Valve Springs And Plug

J9321-433

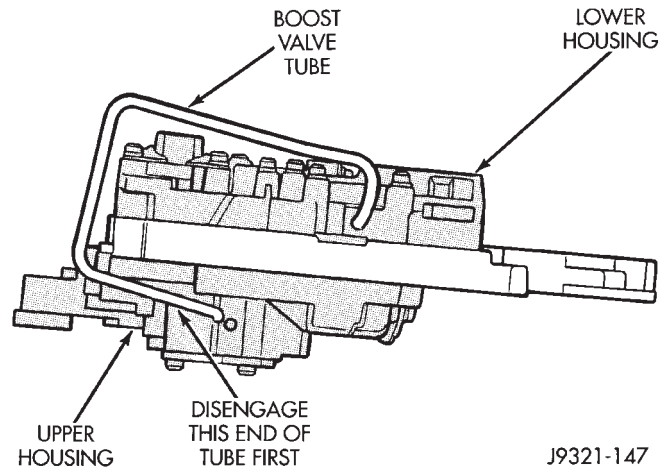


Fig. 59 Boost Valve Tube

J9321-147

60). **Note position of boost valve tube brace for assembly reference.**

(30) Remove lower housing and overdrive separator plate from transfer plate (Fig. 60).

(31) Remove the ECE check ball from the transfer plate (Fig. 61). The ECE check ball is approximately 4.8 mm (3/16 in.) in diameter.

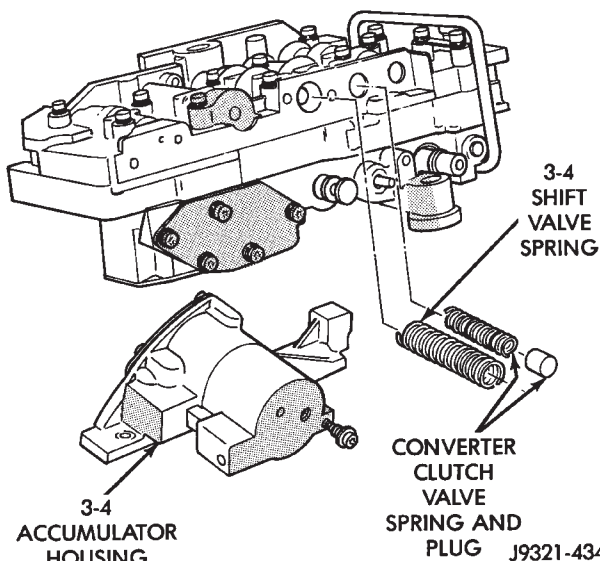


Fig. 57 Accumulator Housing, Valve Springs And Plug

J9321-434

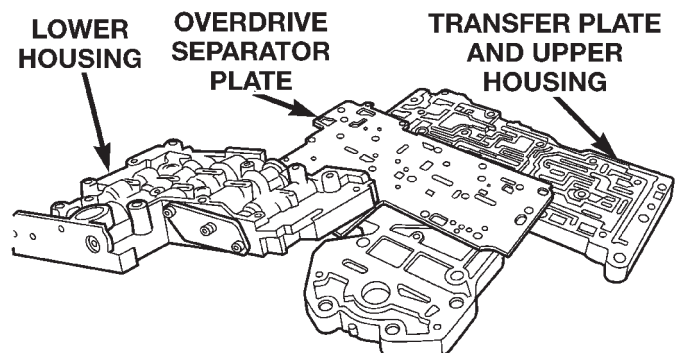


Fig. 60 Lower Housing

80b170f8

DISASSEMBLY AND ASSEMBLY (Continued)

(32) Remove transfer plate from upper housing (Fig. 62).

(33) Turn transfer plate over so upper housing separator plate is facing upward.

(34) Remove upper housing separator plate from transfer plate (Fig. 63). Note position of filter in separator plate for assembly reference.

(35) Remove rear clutch and rear servo check balls from transfer plate. Note check ball location for assembly reference (Fig. 64).

VALVE BODY UPPER HOUSING

(1) Note location of check balls in valve body upper housing (Fig. 65). Then remove the one large diameter and the six smaller diameter check balls.

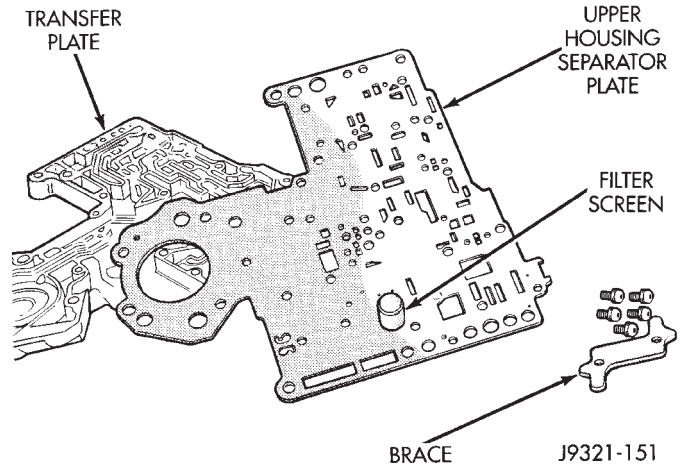


Fig. 63 Upper Housing Separator Plate

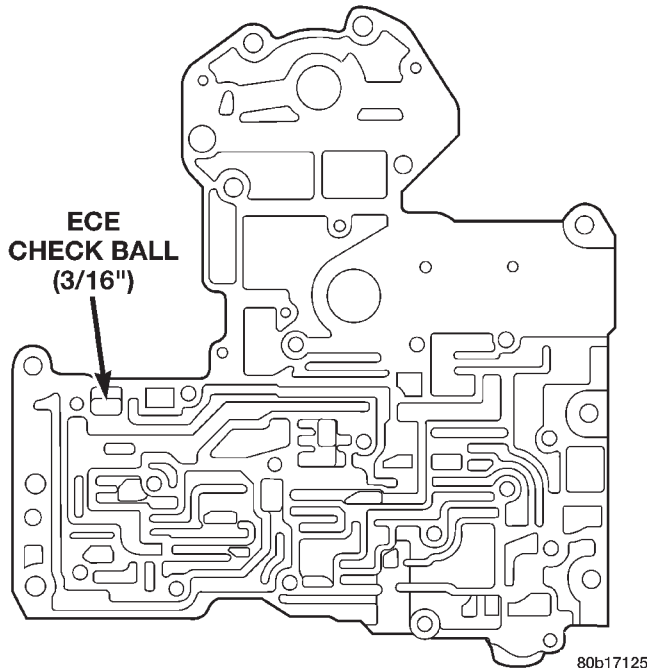


Fig. 61 ECE Check Ball

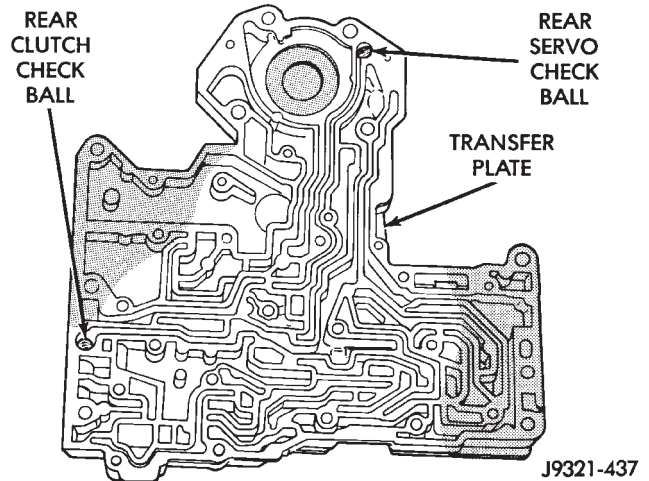


Fig. 64 Rear Clutch And Rear Servo Check Ball Locations

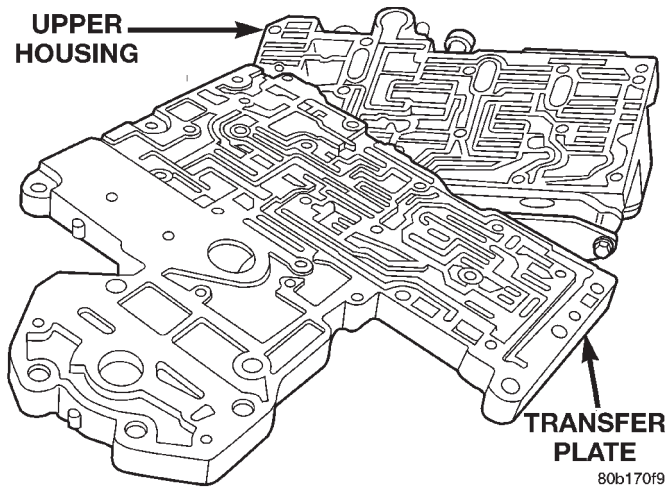


Fig. 62 Transfer Plate

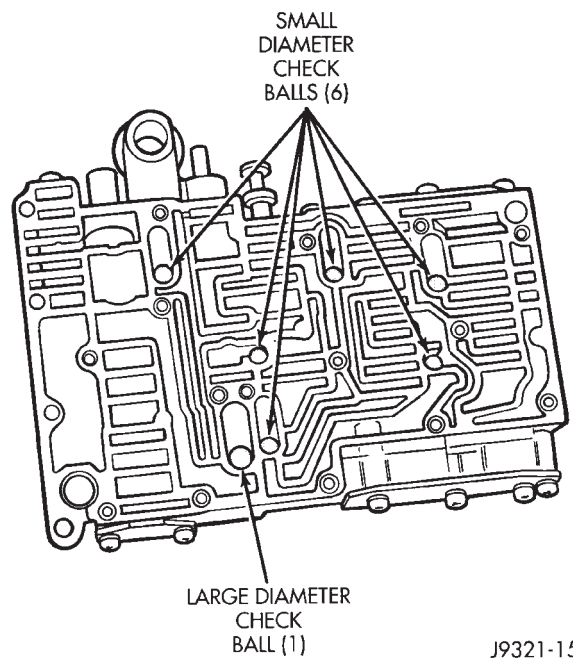


Fig. 65 Check Ball Locations In Upper Housing

DISASSEMBLY AND ASSEMBLY (Continued)

- (2) Remove governor plug and shuttle valve covers (Fig. 67).
- (3) Remove E-clip that secures shuttle valve secondary spring on valve stem (Fig. 66).
- (4) Remove throttle plug, primary spring, shuttle valve, secondary spring, and spring guides (Fig. 67).
- (5) Remove boost valve retainer, spring and valve if not previously removed.
- (6) Remove throttle plug and 1-2 and 2-3 governor plugs (Fig. 54).
- (7) Turn upper housing around and remove limit valve and shift valve covers (Fig. 68).
- (8) Remove limit valve housing. Then remove retainer, spring, limit valve, and 2-3 throttle plug from limit valve housing (Fig. 68).
- (9) Remove 1-2 shift control valve and spring (Fig. 68).
- (10) Remove 1-2 shift valve and spring (Fig. 68).
- (11) Remove 2-3 shift valve and spring from valve body (Fig. 68).
- (12) Remove pressure plug cover (Fig. 68).
- (13) Remove line pressure plug, sleeve, throttle pressure plug and spring (Fig. 68).

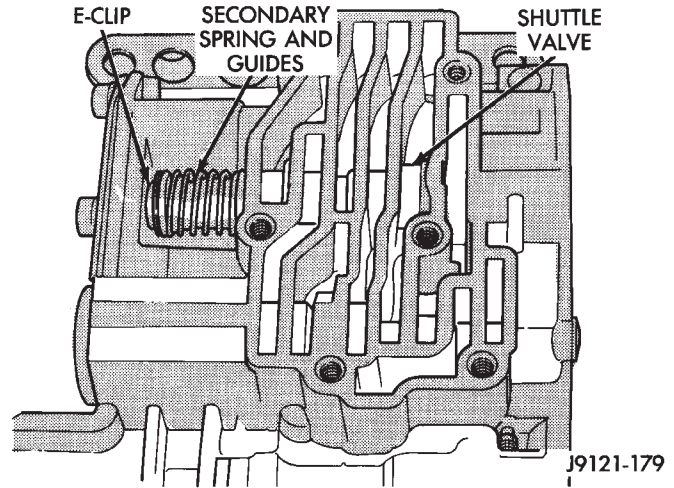


Fig. 66 Shuttle Valve E-Clip And Secondary Spring Location

- (3) Remove 3-4 quick fill valve, spring and plug.
- (4) Remove 3-4 shift valve and spring.
- (5) Remove converter clutch valve, spring and plug (Fig. 69).

VALVE BODY LOWER HOUSING

- (1) Remove timing valve cover.
- (2) Remove 3-4 timing valve and spring.

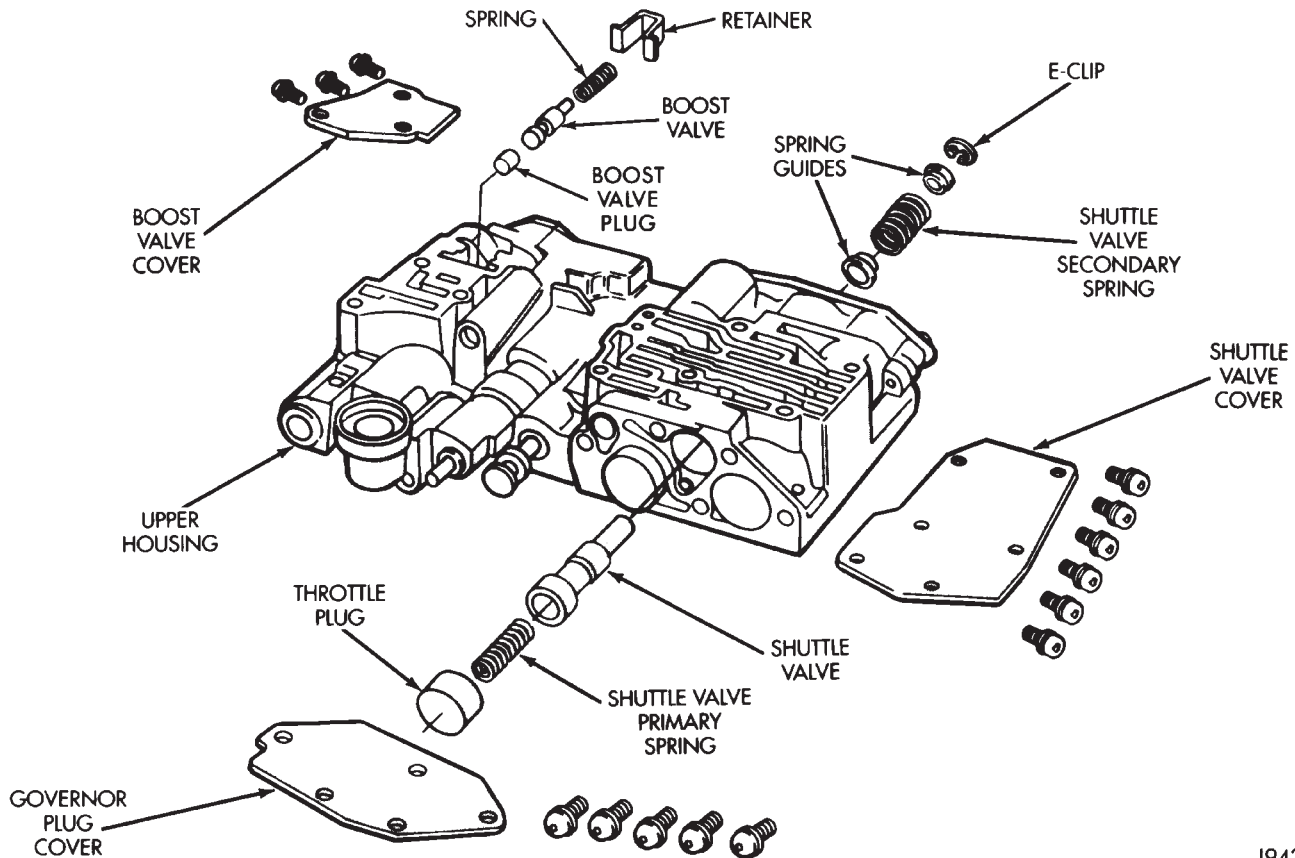


Fig. 67 Shuttle And Boost Valve Components

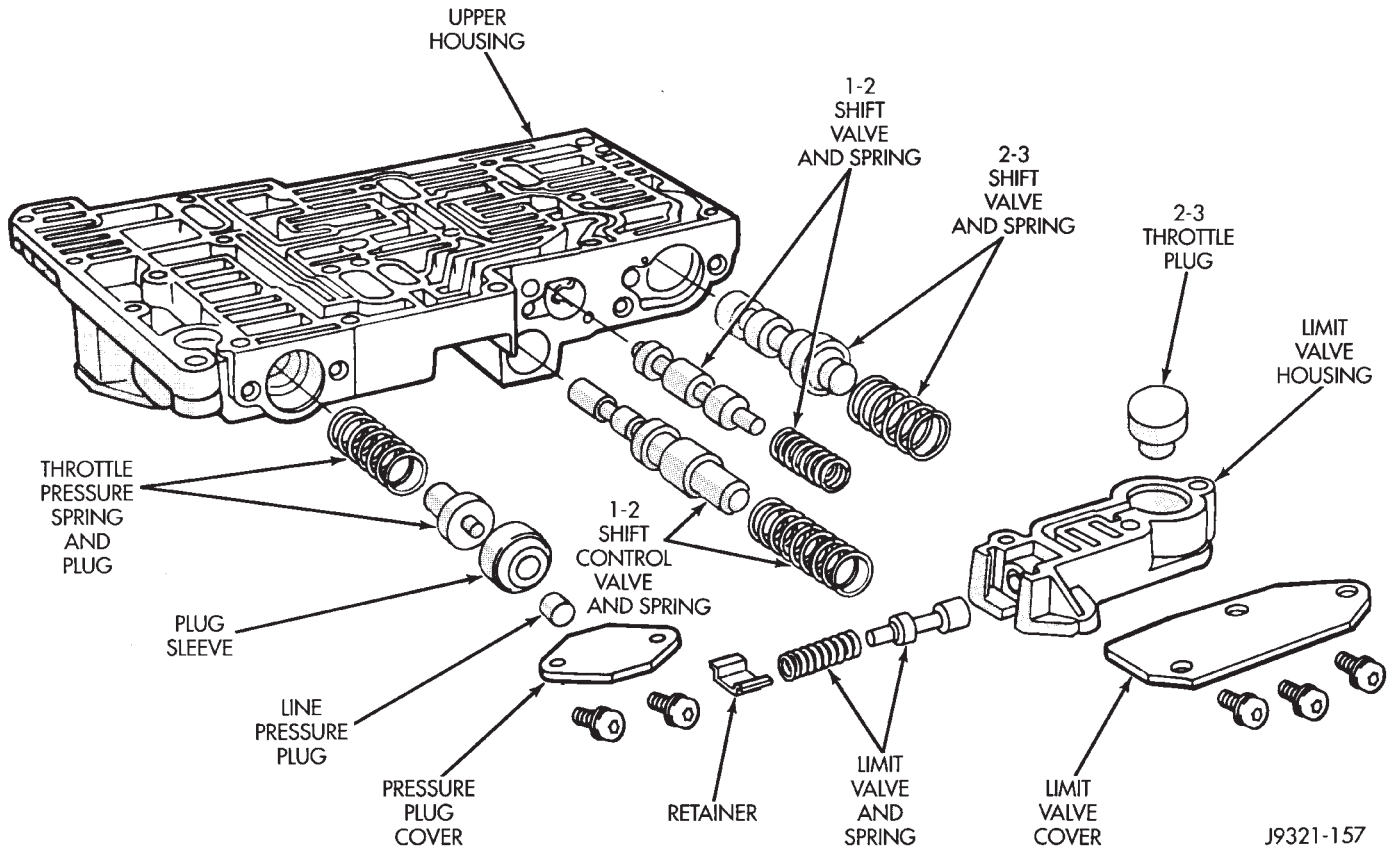
DISASSEMBLY AND ASSEMBLY (Continued)

Fig. 68 Upper Housing Shift Valve And Pressure Plug Locations

(6) Remove converter clutch timing valve, retainer and valve spring.

3-4 ACCUMULATOR HOUSING

- (1) Remove end plate from housing.
- (2) Remove piston spring.
- (3) Remove piston. Remove and discard piston seals (Fig. 70).

ASSEMBLY

CAUTION: Do not force valves or plugs into place during reassembly. If the valve body bores, valves and plugs are free of distortion or burrs, the valve body components should all slide into place easily. In addition, do not overtighten the transfer plate and valve body screws during reassembly. Overtightening can distort the housings resulting in valve sticking, cross leakage and unsatisfactory operation. Tighten valve body screws to recommended torque only.

LOWER HOUSING

- (1) Lubricate valves, springs, and the housing valve and plug bores with clean transmission fluid (Fig. 69).

- (2) Install 3-4 timing valve spring and valve in lower housing.

- (3) Install 3-4 quick fill valve in lower housing.

- (4) Install 3-4 quick fill valve spring and plug in housing.

- (5) Install timing valve end plate. Tighten end plate screws to 4 N·m (35 in. lbs.) torque.

3-4 ACCUMULATOR

- (1) Lubricate accumulator piston, seals and housing piston bore with clean transmission fluid (Fig. 70).

- (2) Install new seal rings on accumulator piston.

- (3) Install piston and spring in housing.

- (4) Install end plate on housing.

TRANSFER PLATE

- (1) Install rear clutch and rear servo check balls in transfer plate (Fig. 71).

- (2) Install filter screen in upper housing separator plate (Fig. 72).

- (3) Align and position upper housing separator plate on transfer plate (Fig. 73).

- (4) Install brace plate (Fig. 73). Tighten brace attaching screws to 4 N·m (35 in. lbs.) torque.

- (5) Install remaining separator plate attaching screws. Tighten screws to 4 N·m (35 in. lbs.) torque.

DISASSEMBLY AND ASSEMBLY (Continued)

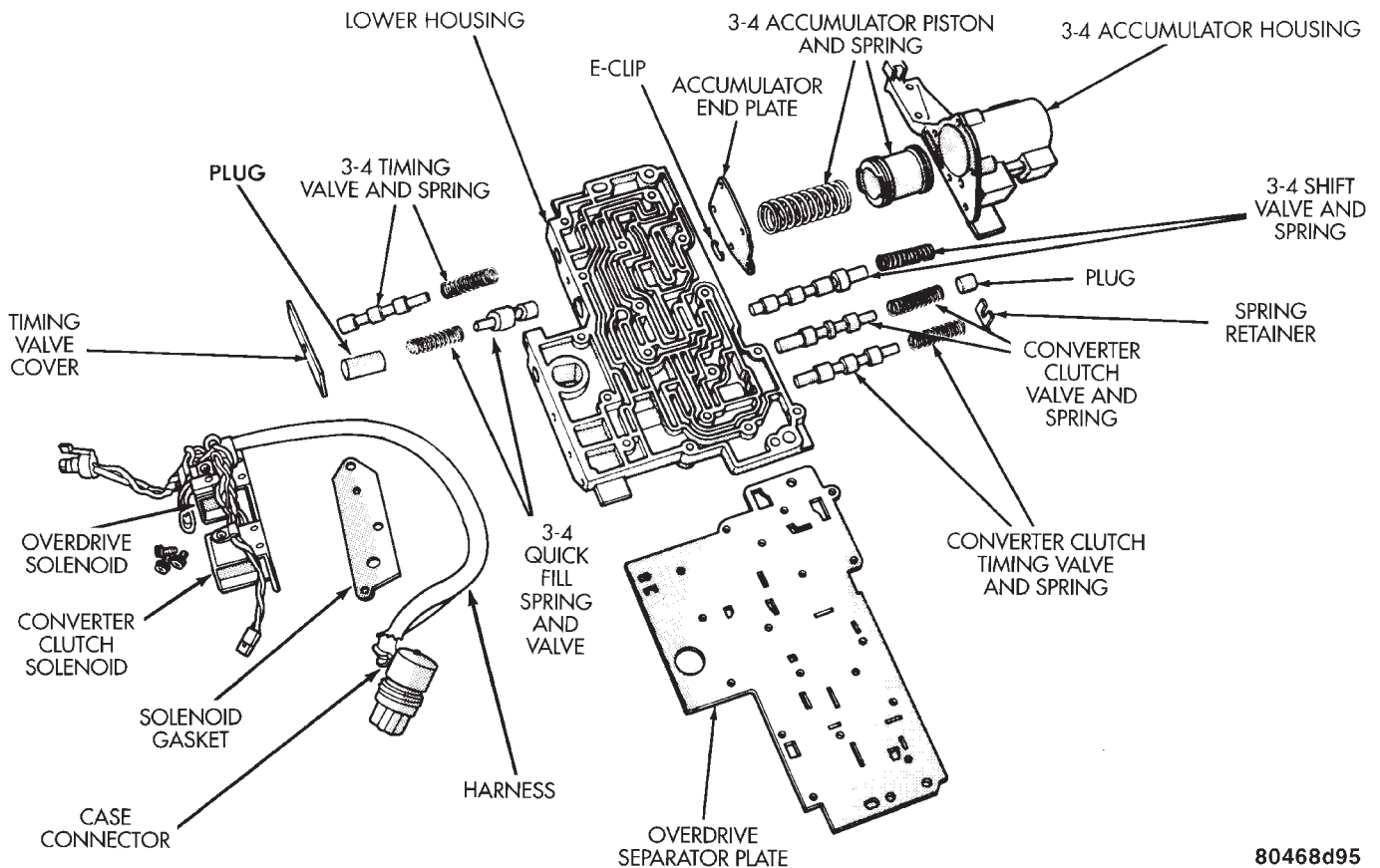


Fig. 69 Lower Housing Shift Valves And Springs

80468d95

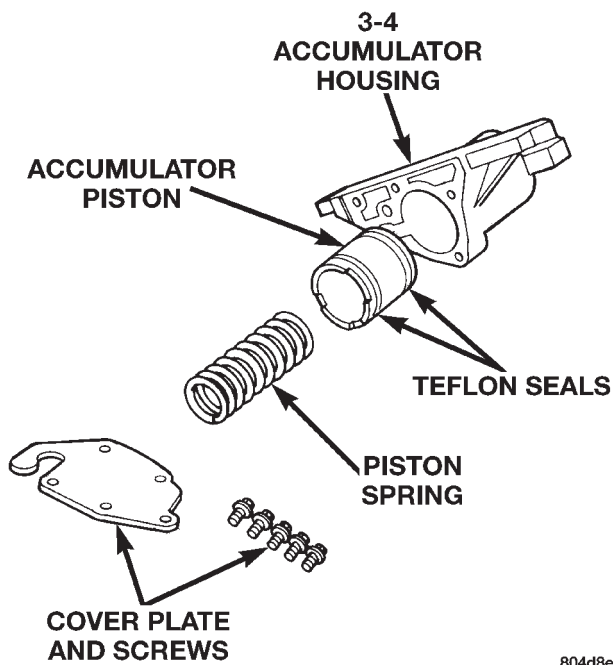
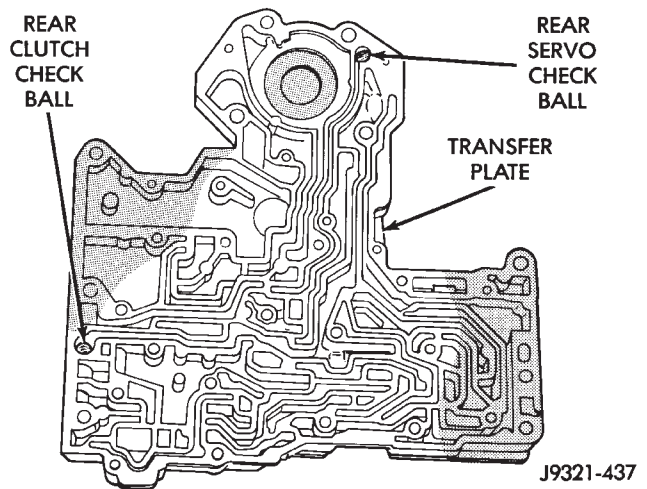


Fig. 70 Accumulator Housing Components

804d8eb9



J9321-437

Fig. 71 Rear Clutch And Rear Servo Check Ball Locations

UPPER AND LOWER HOUSING

(1) Position upper housing so internal passages and check ball seats are facing upward. Then install check balls in housing (Fig. 74). Seven check balls are used. The single large check ball is approximately 8.7 mm (11/32 in.) diameter. The single small check ball is approximately 4.8 mm (3/16 in.) in

DISASSEMBLY AND ASSEMBLY (Continued)

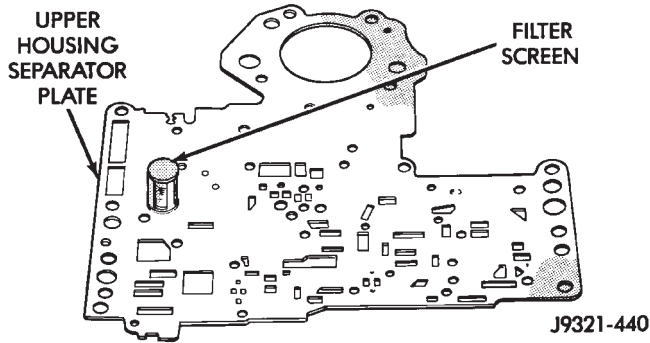


Fig. 72 Separator Plate Filter Screen Installation

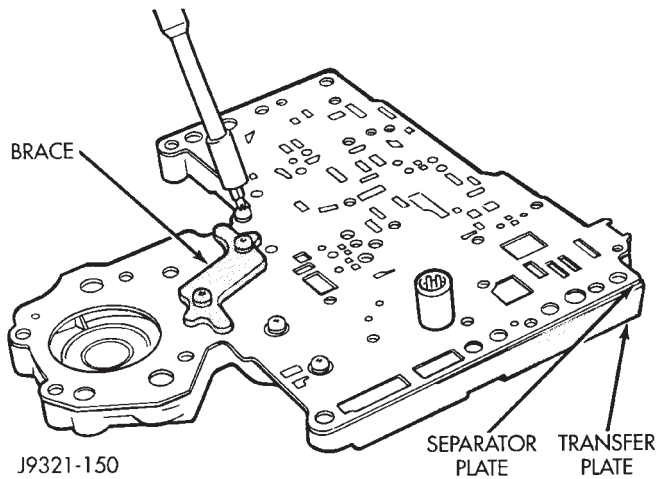


Fig. 73 Brace Plate

diameter. The remaining 6 check balls are approximately 6.3 mm (1/4 in.) in diameter.

(2) Position assembled transfer plate and upper housing separator plate on upper housing (Fig. 75).

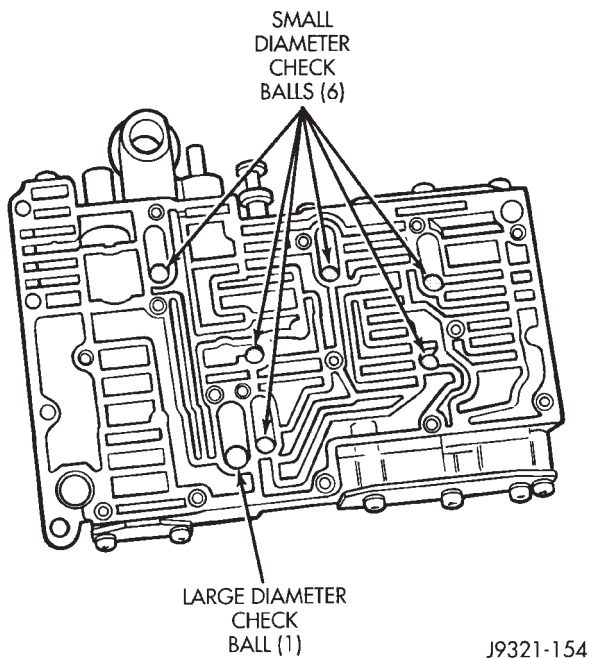


Fig. 74 Check Ball Locations In Upper Housing

Be sure filter screen is seated in proper housing recess.

(3) Install the ECE check ball into the transfer plate (Fig. 61). The ECE check ball is approximately 4.8 mm (3/16 in.) in diameter.

(4) Position lower housing separator plate on transfer plate (Fig. 76).

(5) Install lower housing on assembled transfer plate and upper housing (Fig. 77).

(6) Install and start all valve body screws by hand except for the screws to hold the boost valve tube brace. Save those screws for later installation. Then tighten screws evenly to 4 N·m (35 in. lbs.) torque. Start at center and work out to sides when tightening screws (Fig. 77).

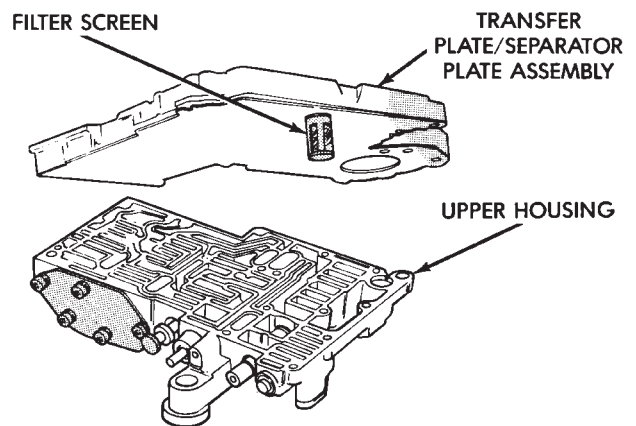


Fig. 75 Installing Transfer Plate On Upper Housing

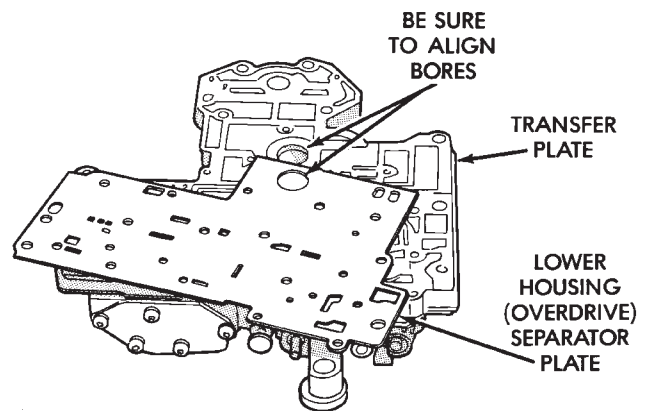


Fig. 76 Lower Housing Separator Plate

UPPER HOUSING VALVE AND PLUG

Refer to (Fig. 78), (Fig. 79) and (Fig. 80) to perform the following steps.

(1) Lubricate valves, plugs, springs with clean transmission fluid.

DISASSEMBLY AND ASSEMBLY (Continued)

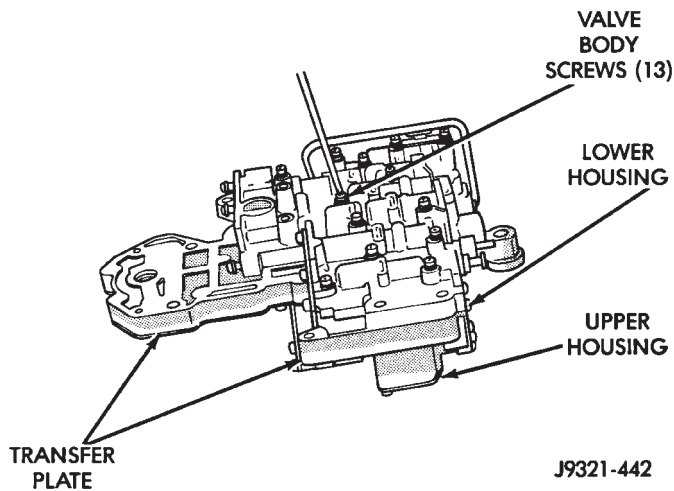


Fig. 77 Installing Lower Housing On Transfer Plate And Upper Housing

(2) Assemble regulator valve line pressure plug, sleeve, throttle plug and spring. Insert assembly in upper housing and install cover plate. Tighten cover plate screws to 4 N·m (35 in. lbs.) torque.

- (3) Install 1-2 and 2-3 shift valves and springs.
- (4) Install 1-2 shift control valve and spring.
- (5) Install retainer, spring, limit valve, and 2-3 throttle plug from limit valve housing.
- (6) Install limit valve housing and cover plate. Tighten screws to 4 N·m (35 in. lbs.).
- (7) Install shuttle valve as follows:
 - (a) Insert plastic guides in shuttle valve secondary spring and install spring on end of valve.
 - (b) Install shuttle valve into housing.
 - (c) Hold shuttle valve in place.
 - (d) Compress secondary spring and install E-clip in groove at end of shuttle valve.
 - (e) Verify that spring and E-clip are properly seated before proceeding.
- (8) Install shuttle valve cover plate. Tighten cover plate screws to 4 N·m (35 in. lbs.) torque.
- (9) Install 1-2 and 2-3 valve governor plugs in valve body.
- (10) Install shuttle valve primary spring and throttle plug.
- (11) Align and install governor plug cover. Tighten cover screws to 4 N·m (35 in. lbs.) torque.

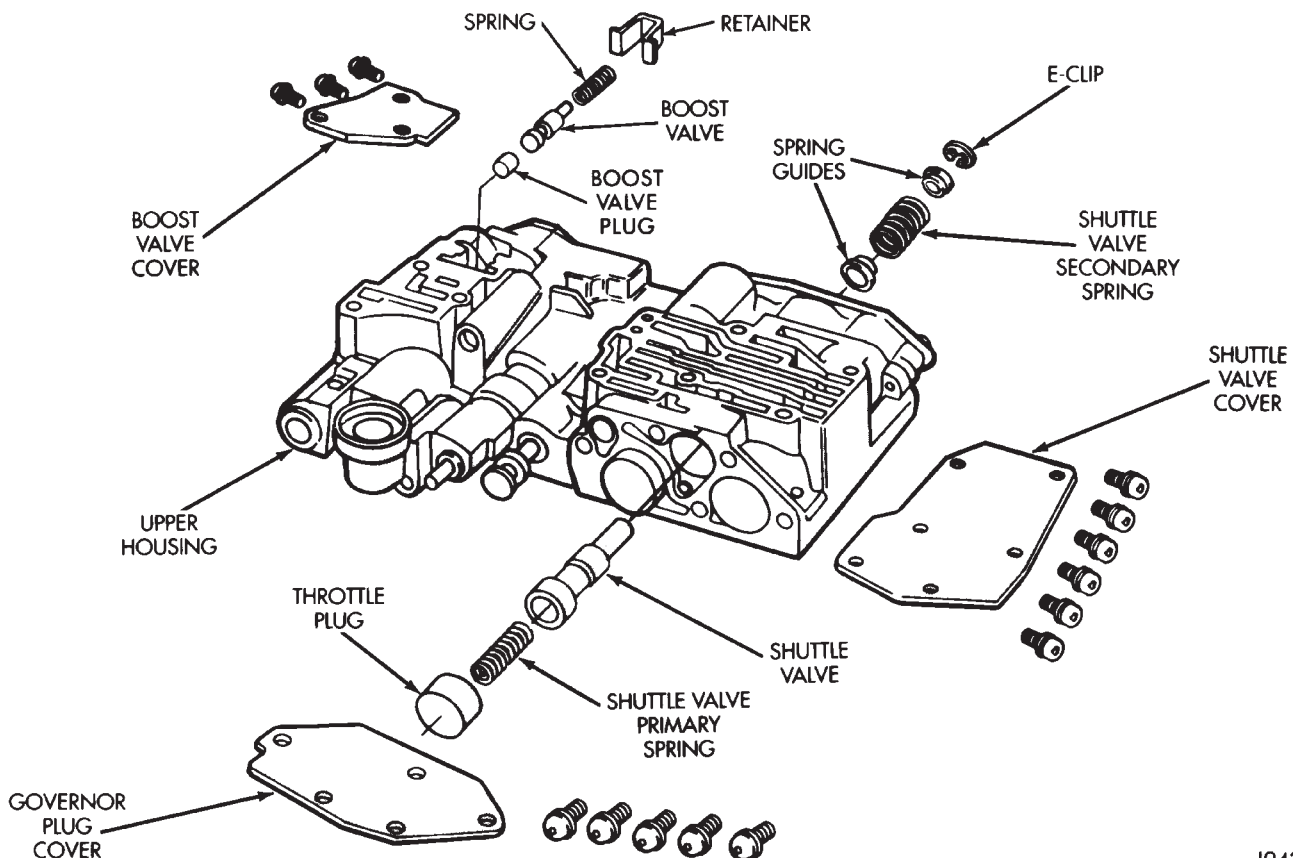


Fig. 78 Shuttle And Boost Valve Components

DISASSEMBLY AND ASSEMBLY (Continued)

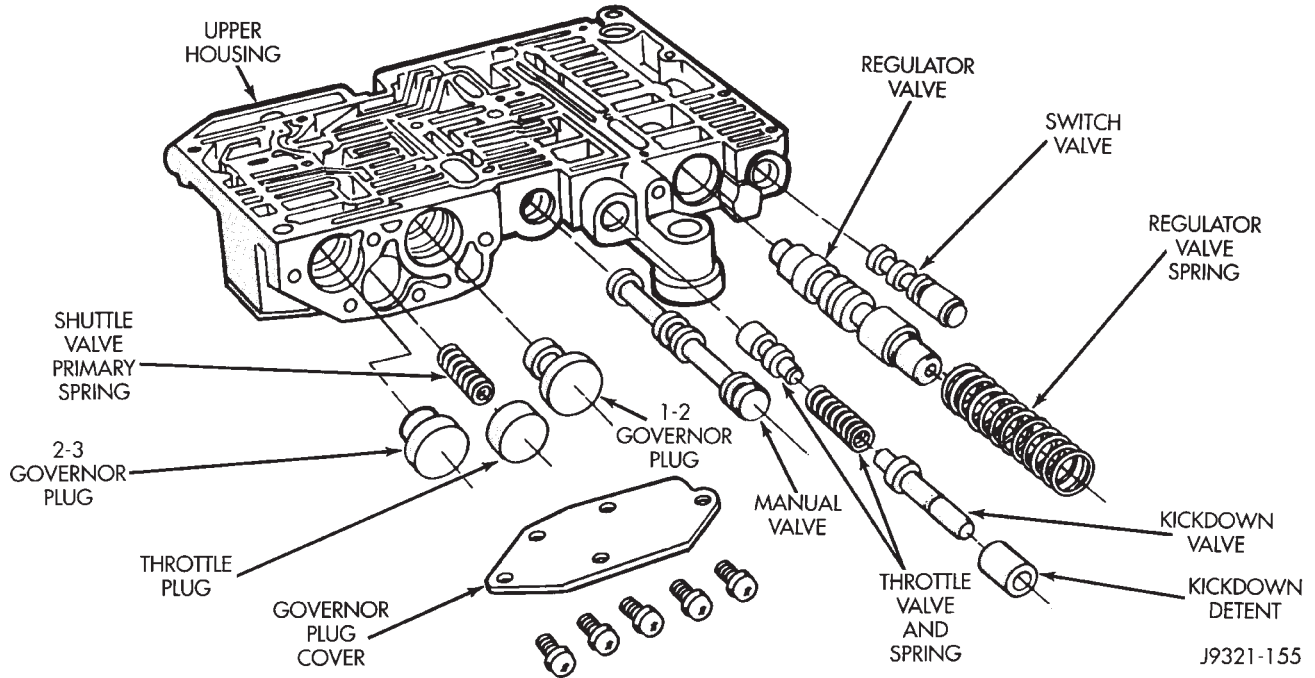


Fig. 79 Upper Housing Control Valve Locations

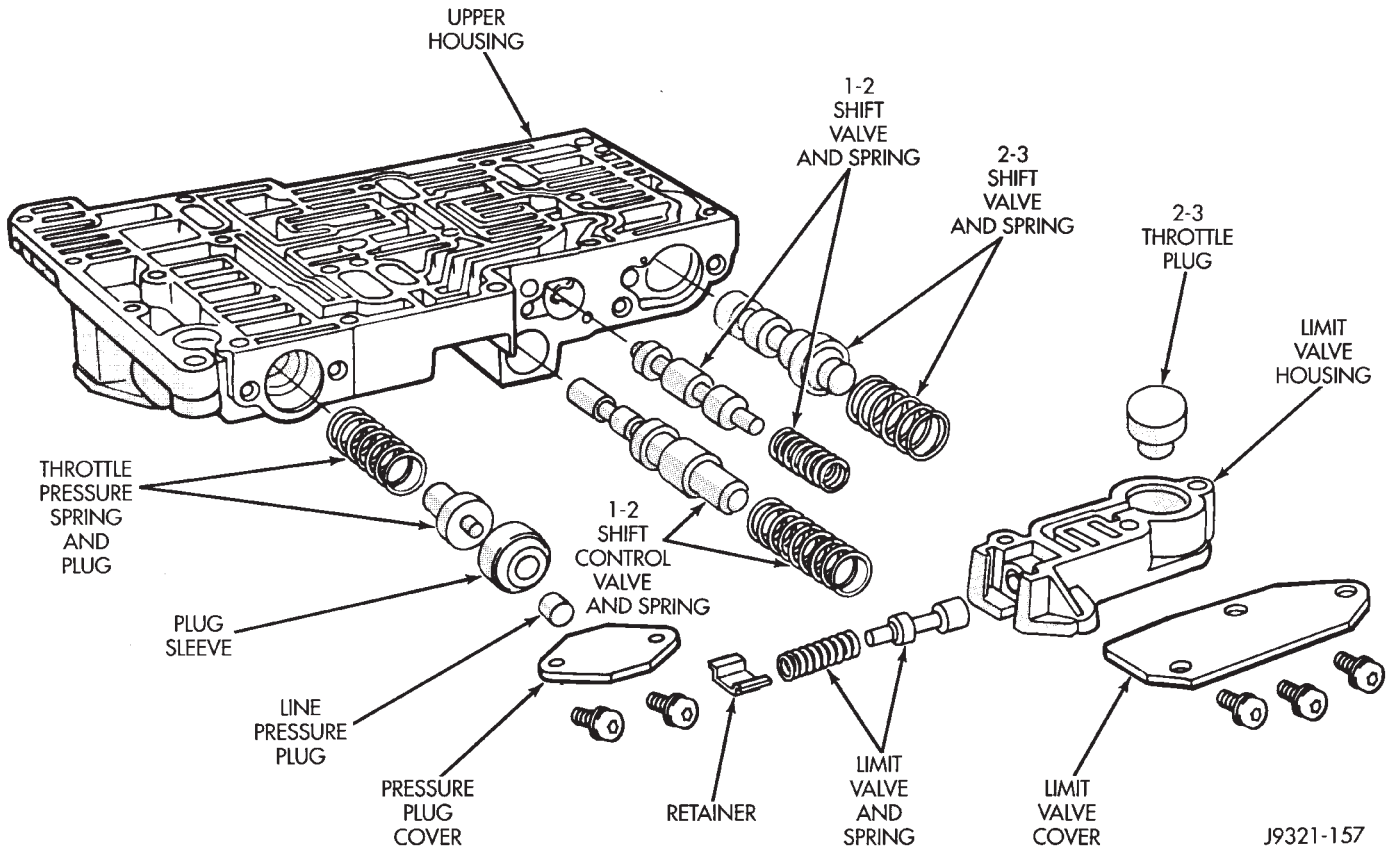


Fig. 80 Upper Housing Shift Valve And Pressure Plug Locations

DISASSEMBLY AND ASSEMBLY (Continued)

BOOST VALVE TUBE AND BRACE

- (1) Position valve body assembly so lower housing is facing upward (Fig. 81).
- (2) Lubricate tube ends and housing ports with transmission fluid or petroleum jelly.
- (3) Start tube in lower housing port first. Then swing tube downward and work opposite end of tube into upper housing port (Fig. 81).
- (4) Insert and seat each end of tube in housings.
- (5) Slide tube brace under tube and into alignment with valve body screw holes (Fig. 82).
- (6) Install and finger tighten three screws that secure tube brace to valve body housings (Fig. 82).
- (7) Bend tube brace tabs up and against tube to hold it in position (Fig. 83).
- (8) Tighten all valve body housing screws to 4 N·m (35 in. lbs.) torque after tube and brace are installed. Tighten screws in diagonal pattern starting at center and working outward.

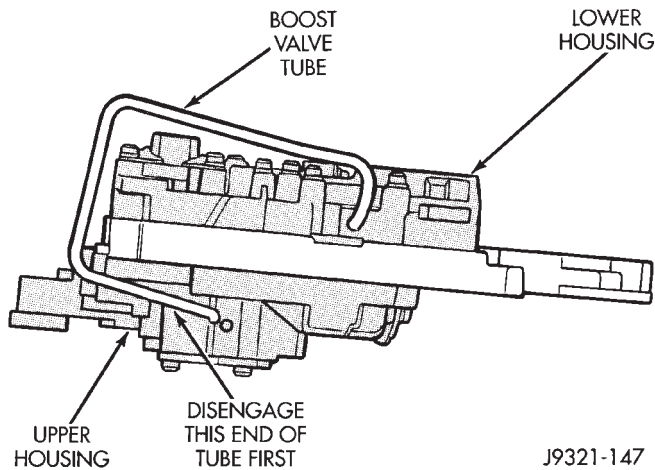


Fig. 81 Boost Valve Tube

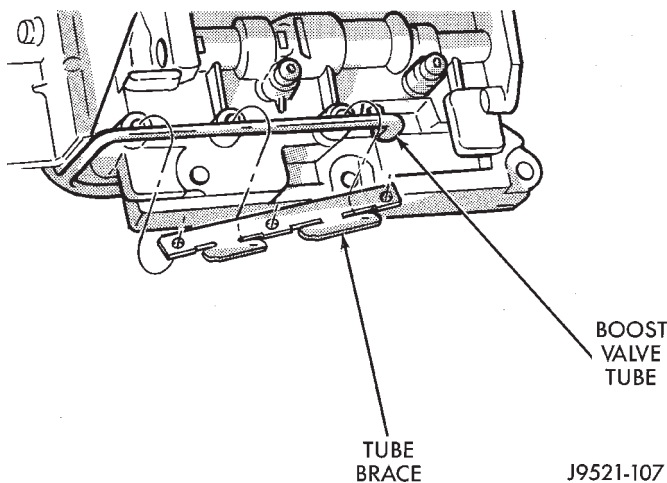


Fig. 82 Boost Valve Tube And Brace

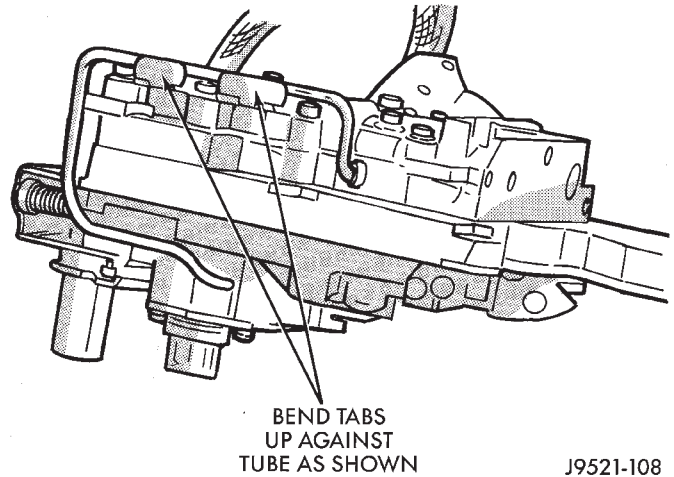


Fig. 83 Securing Boost Valve Tube With Brace Tabs

3-4 ACCUMULATOR

- (1) Position converter clutch valve and 3-4 shift valve springs in housing (Fig. 84).
- (2) Loosely attach accumulator housing with right-side screw (Fig. 84). Install only one screw at this time as accumulator must be free to pivot upward for ease of installation.
- (3) Install 3-4 shift valve and spring.
- (4) Install converter clutch timing valve and spring.
- (5) Position plug on end of converter clutch valve spring. Then compress and hold springs and plug in place with fingers of one hand.
- (6) Swing accumulator housing upward over valve springs and plug.
- (7) Hold accumulator housing firmly in place and install remaining two attaching screws. Be sure springs and clutch valve plug are properly seated (Fig. 85). Tighten screws to 4 N·m (35 in. lbs.).

VALVE BODY FINAL

- (1) Install boost valve, valve spring, retainer and cover plate. Tighten cover plate screws to 4 N·m (35 in. lbs.) torque.
- (2) Insert manual lever detent spring in upper housing.
- (3) Position detent ball on end of spring. Then hold detent ball and spring in detent housing with Retainer Tool 6583 (Fig. 86).
- (4) Install throttle lever in upper housing. Then install manual lever over throttle lever and start manual lever into housing.
- (5) Align manual lever with detent ball and manual valve. Hold throttle lever upward. Then press down on manual lever until fully seated. Remove detent ball retainer tool after lever is seated.
- (6) Then install manual lever seal, washer and E-clip.

DISASSEMBLY AND ASSEMBLY (Continued)

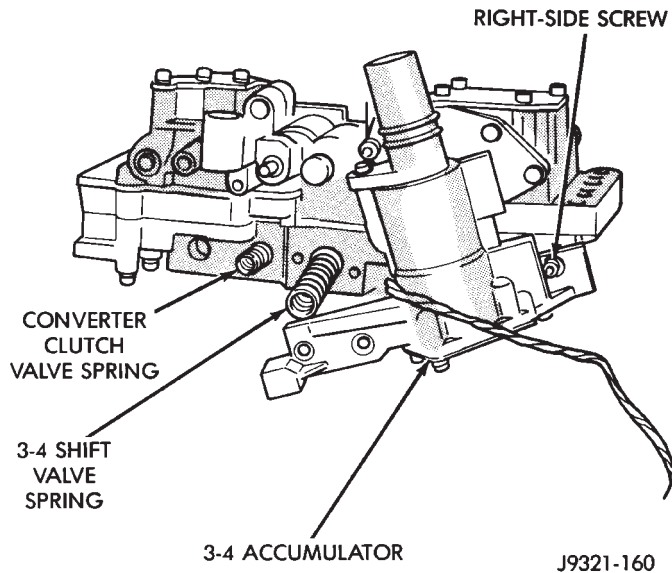


Fig. 84 Converter Clutch And 3-4 Shift Valve Springs

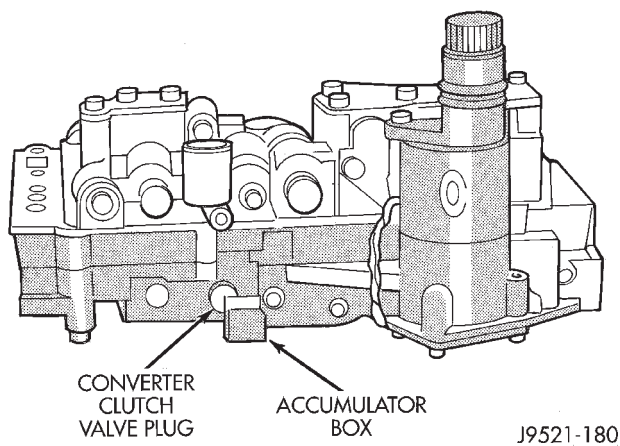


Fig. 85 Seating 3-4 Accumulator On Lower Housing

(7) Verify that throttle lever is aligned with end of kickdown valve stem and that manual lever arm is engaged in manual valve (Fig. 87).

(8) Position line pressure adjusting screw in adjusting screw bracket.

(9) Install spring on end of line pressure regulator valve.

(10) Install switch valve spring on tang at end of adjusting screw bracket.

(11) Install manual valve.

(12) Install throttle valve and spring.

(13) Install kickdown valve and detent.

(14) Install pressure regulator valve.

(15) Install switch valve.

(16) Position adjusting screw bracket on valve body. Align valve springs and press bracket into place. Install short, upper bracket screws first and long bottom screw last. Verify that valve springs and

bracket are properly aligned. Then tighten all three bracket screws to 4 N·m (35 in. lbs.) torque.

(17) Lubricate solenoid case connector O-rings and shaft of manual lever with light coat of petroleum jelly.

(18) Obtain new fluid filter for valve body but do not install filter at this time.

(19) If line pressure and/or throttle pressure adjustment screw settings were not disturbed, continue with overhaul or reassembly. However, if adjustment screw settings **were** moved or changed, readjust as described in Valve Body Control Pressure Adjustment procedure.

(20) Attach solenoid case connector to 3-4 accumulator with shoulder-type screw. Connector has small locating tang that fits in dimple at top of accumulator housing (Fig. 88). Seat tang in dimple before tightening connector screw.

(21) Install solenoid assembly and gasket. Tighten solenoid attaching screws to 8 N·m (72 in. lbs.) torque.

(22) Verify that solenoid wire harness is properly routed (Fig. 89). **Solenoid harness must be clear of manual lever and park rod and not be pinched between accumulator housing and cover.**

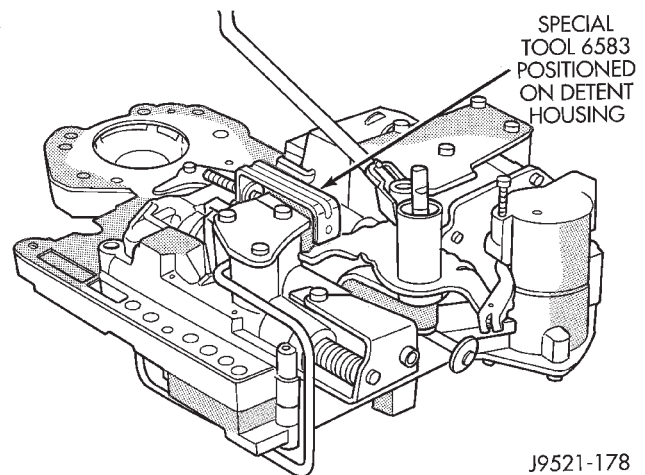


Fig. 86 Detent Ball Spring

GOVERNOR BODY, SENSOR AND SOLENOID

(1) Turn valve body assembly over so accumulator side of transfer plate is facing down.

(2) Install new O-rings on governor pressure solenoid and sensor.

(3) Lubricate solenoid and sensor O-rings with clean transmission fluid.

(4) Install governor pressure sensor in governor body. Then secure sensor with M-shaped retaining clip.

(5) Install governor pressure solenoid in governor body. Push solenoid in until it snaps into place in body.

DISASSEMBLY AND ASSEMBLY (Continued)

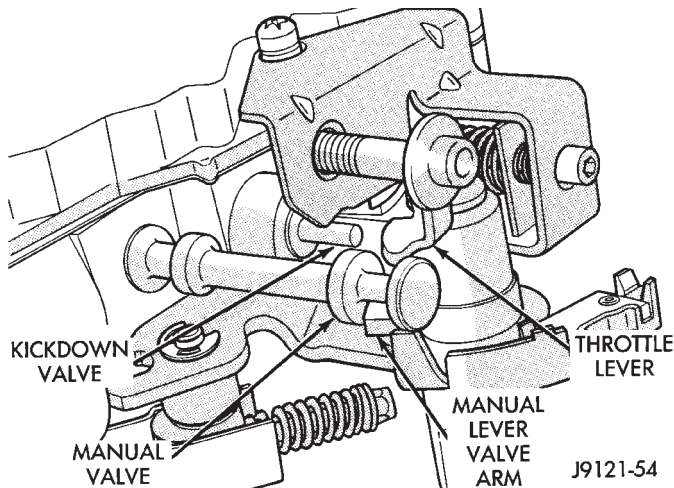


Fig. 87 Manual And Throttle Lever Alignment

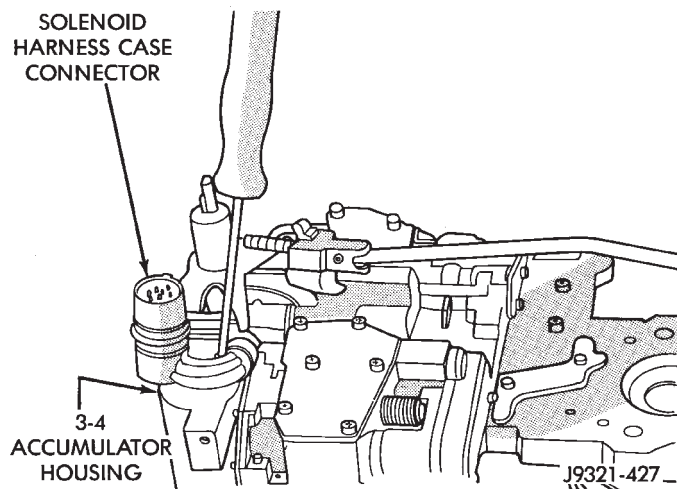


Fig. 88 Solenoid Harness Case Connector Shoulder Bolt

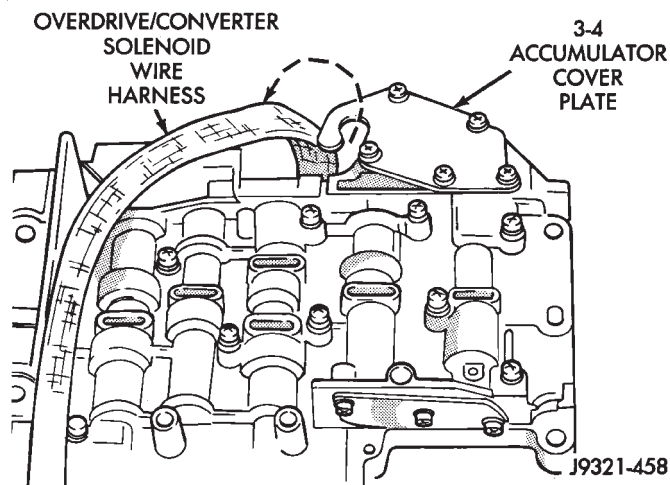


Fig. 89 Solenoid Harness Routing

(6) Position governor body gasket on transfer plate.

(7) Install retainer plate on governor body and around solenoid. Be sure solenoid connector is positioned in retainer cutout.

(8) Align screw holes in governor body and transfer plate. Then install and tighten governor body screws to 4 N-m (35 in. lbs.) torque.

(9) Connect harness wires to governor pressure solenoid and governor pressure sensor.

(10) Perform Line Pressure and Throttle Pressure adjustments. Refer to adjustment section of this group for proper procedures.

(11) Install fluid filter and pan.

(12) Lower vehicle.

(13) Fill transmission with recommended fluid and road test vehicle to verify repair.

TRANSMISSION

DISASSEMBLY

(1) Clean transmission exterior with steam gun or with solvent. Wear eye protection during cleaning operations.

(2) Place transmission in a vertical position.

(3) Measure and record input shaft end play readings.

(4) Remove shift and throttle levers from valve body manual lever shaft.

(5) Place transmission in horizontal position.

(6) Remove transmission oil pan and gasket.

(7) Remove filter from valve body (Fig. 90). Keep filter screws separate from other valve body screws. Filter screws are longer and should be kept with filter.

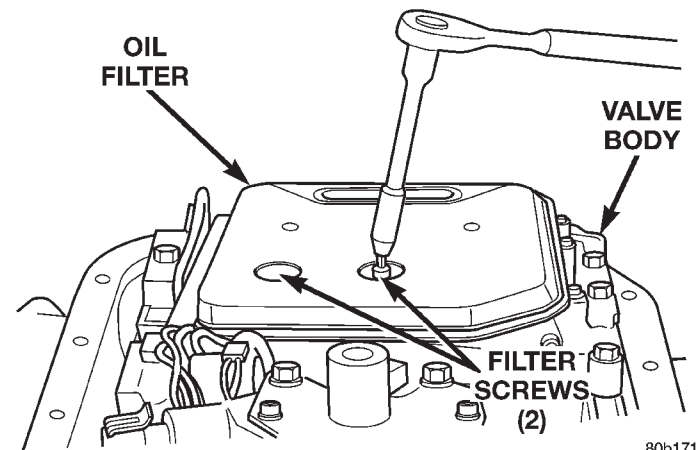


Fig. 90 Oil Filter Removal

(8) Remove park/neutral position switch.

(9) Remove hex head bolts attaching valve body to transmission case (Fig. 91). A total of 10 bolts are used. Note different bolt lengths for assembly reference.

DISASSEMBLY AND ASSEMBLY (Continued)

(10) Remove valve body assembly. Push valve body harness connector out of case. Then work park rod and valve body out of case (Fig. 92).

(11) Remove accumulator piston and inner and outer springs (Fig. 93).

(12) Remove pump oil seal with suitable pry tool or slide-hammer mounted screw.

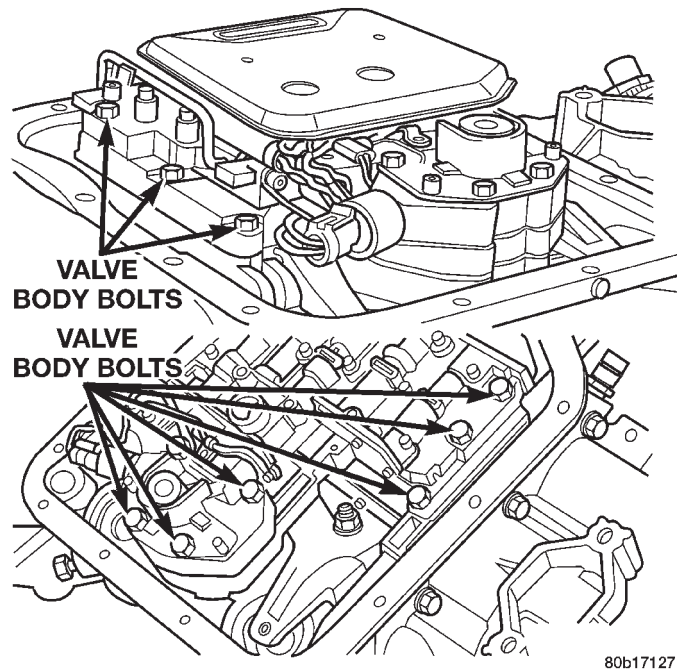


Fig. 91 Valve Body Bolt Locations

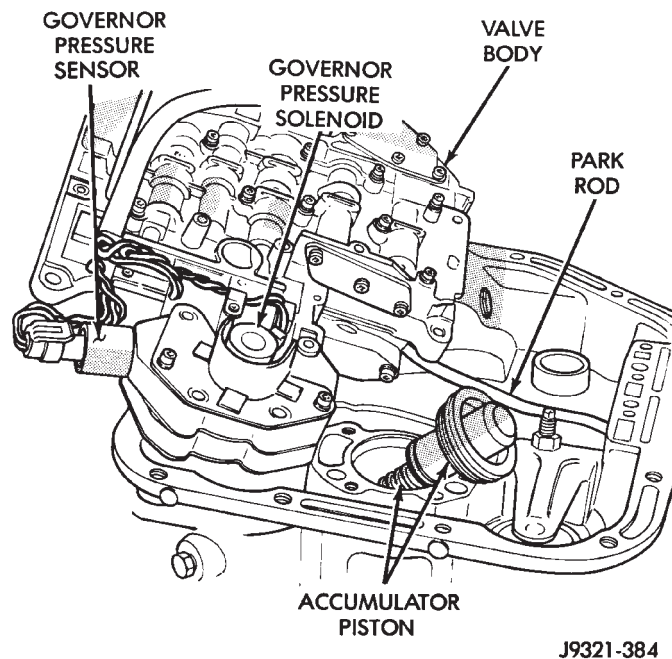


Fig. 92 Valve Body Removal

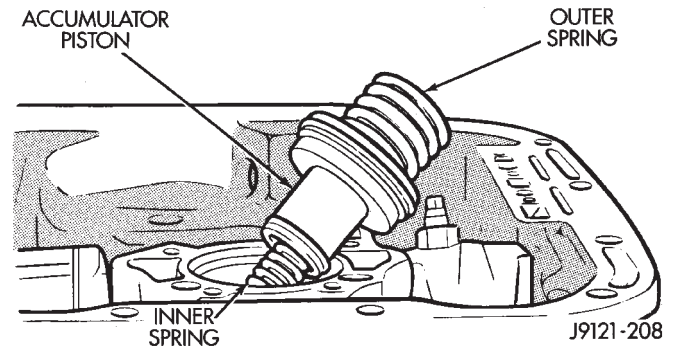


Fig. 93 Accumulator Piston And Springs

(13) Loosen front band adjusting screw locknut 4-5 turns. Then tighten band adjusting screw until band is tight around front clutch retainer. This prevents front/rear clutches from coming out with pump and possibly damaging clutch or pump components.

(14) Remove oil pump bolts.

(15) Thread bolts of Slide Hammer Tools C-3752 into threaded holes in pump body flange (Fig. 94).

(16) Bump slide hammer weights outward to remove pump and reaction shaft support assembly from case (Fig. 94).

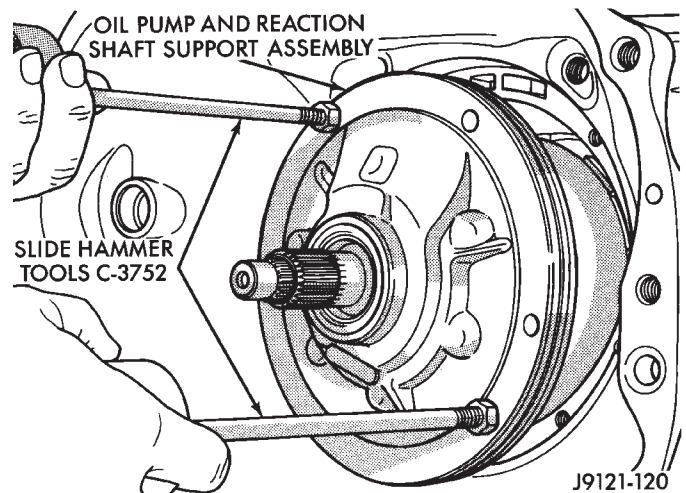


Fig. 94 Removing Oil Pump And Reaction Shaft Support Assembly

(17) Loosen front band adjusting screw until band is completely loose.

(18) Squeeze front band together and remove band strut (Fig. 95).

(19) Remove front band lever (Fig. 96).

(20) Remove front band lever shaft plug, if necessary, from converter housing.

(21) Remove front band lever shaft.

(22) Remove front and rear clutch units as assembly. Grasp input shaft, hold clutch units together and remove them from case (Fig. 97).

(23) Lift front clutch off rear clutch (Fig. 98). Set clutch units aside for overhaul.

DISASSEMBLY AND ASSEMBLY (Continued)

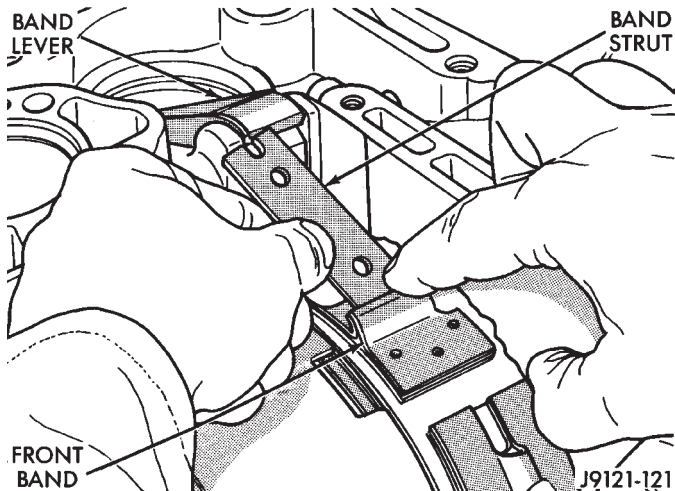


Fig. 95 Removing/Installing Front Band Strut

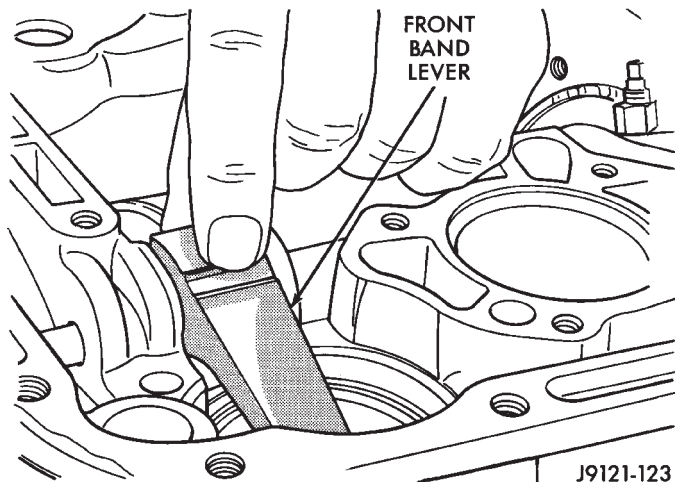


Fig. 96 Removing/Installing Front Band Lever

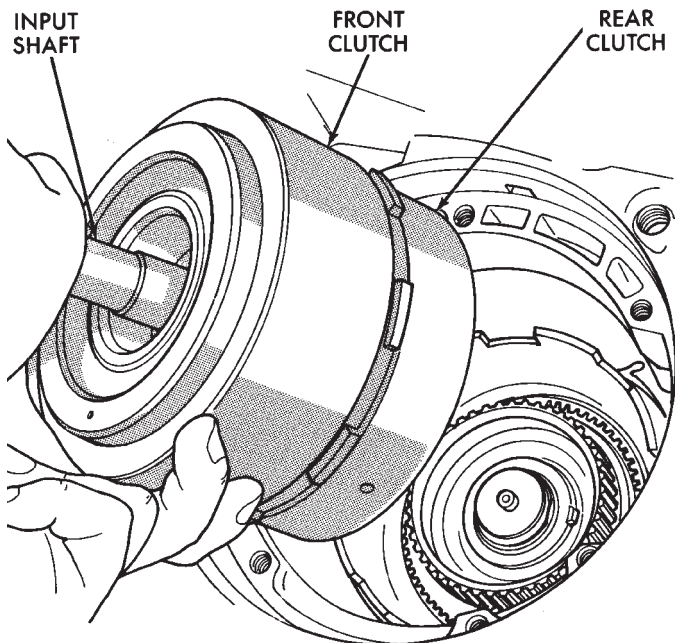


Fig. 97 Removing Front/Rear Clutch Assemblies

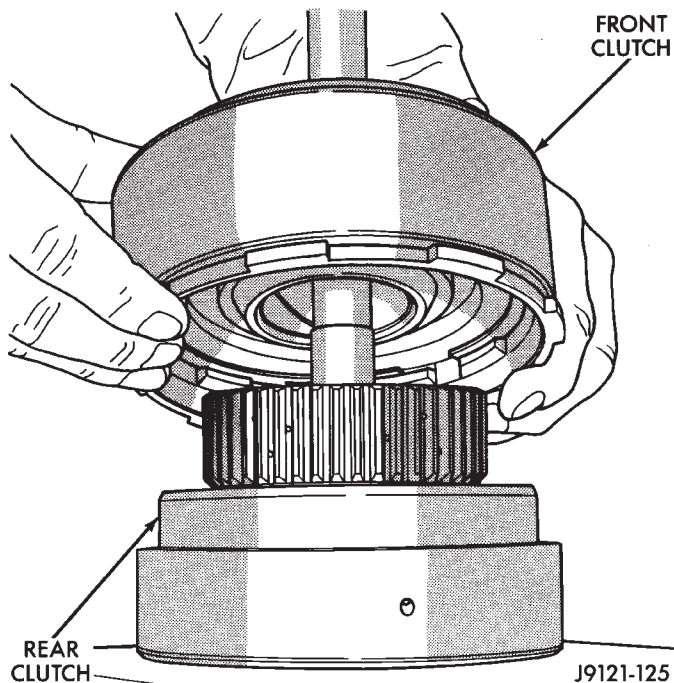


Fig. 98 Separating Front/Rear Clutch Assemblies

(24) Remove intermediate shaft thrust washer from front end of shaft or from rear clutch hub (Fig. 99).

(25) Remove output shaft thrust plate from intermediate shaft hub (Fig. 100).

(26) Slide front band off driving shell (Fig. 101) and remove band from case.

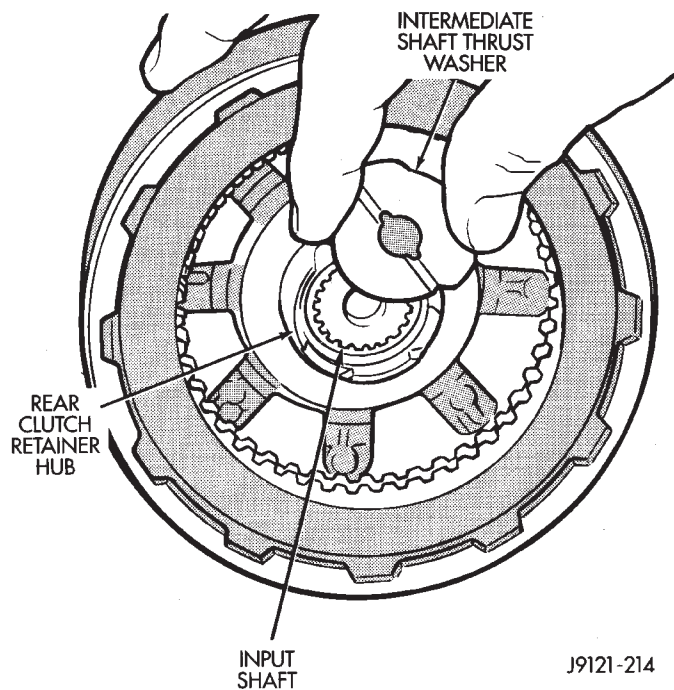


Fig. 99 Removing Intermediate Shaft Thrust Washer

DISASSEMBLY AND ASSEMBLY (Continued)

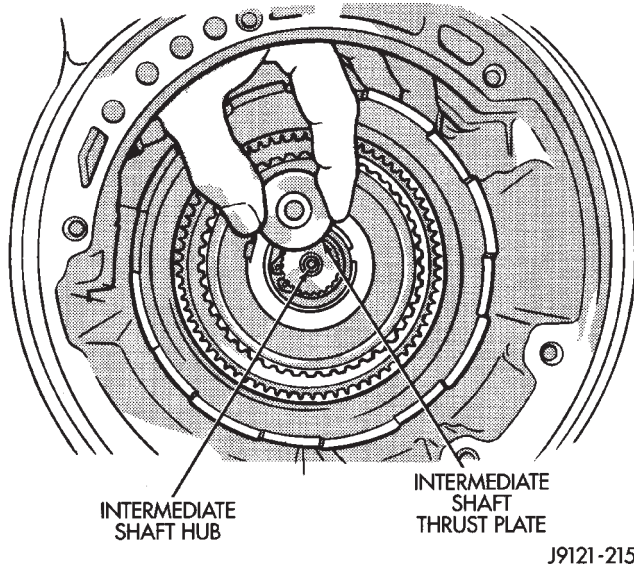


Fig. 100 Removing Intermediate Shaft Thrust Plate

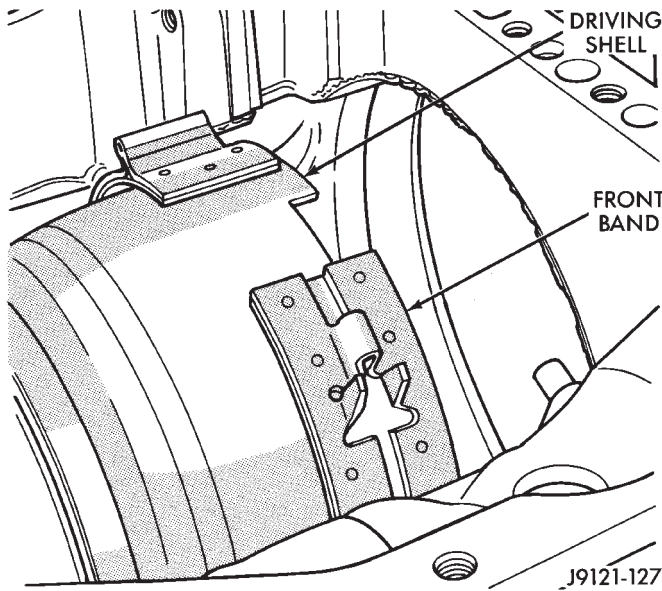


Fig. 101 Front Band Removal/Installation

(27) Remove planetary geartrain as assembly (Fig. 102). Support geartrain with both hands during removal. Do not allow machined surfaces on intermediate shaft or overdrive piston retainer to become nicked or scratched.

(28) If overdrive unit is not to be serviced, install Alignment Shaft 6227-2 into the overdrive unit to prevent misalignment of the overdrive clutches during service of main transmission components.

(29) Loosen rear band adjusting screw 4-5 turns.

(30) Remove low-reverse drum snap ring (Fig. 103).

(31) Remove low-reverse drum and reverse band.

(32) Remove overrunning clutch roller and spring assembly as a unit (Fig. 104).

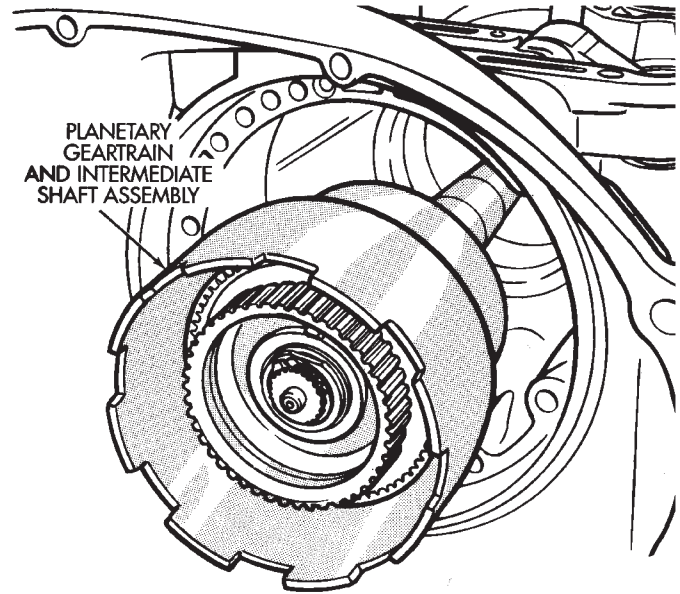


Fig. 102 Removing Planetary Geartrain And Intermediate Shaft Assembly

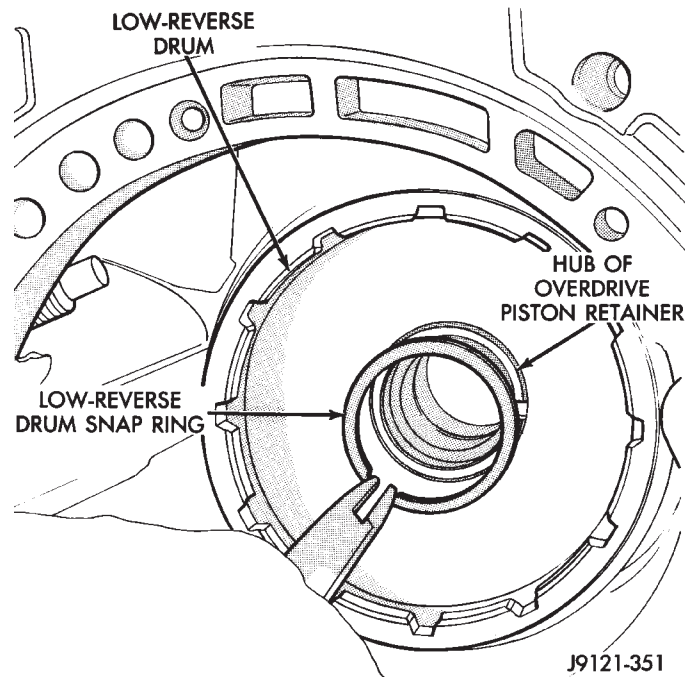


Fig. 103 Removing Low-Reverse Drum Snap Ring

(33) Compress front servo rod guide about 1/8 inch with Valve Spring Compressor C-3422-B (Fig. 105).

(34) Remove front servo rod guide snap ring. **Exercise caution when removing snap ring. Servo bore can be scratched or nicked if care is not exercised.**

(35) Remove compressor tools and remove front servo rod guide, spring and servo piston.

DISASSEMBLY AND ASSEMBLY (Continued)

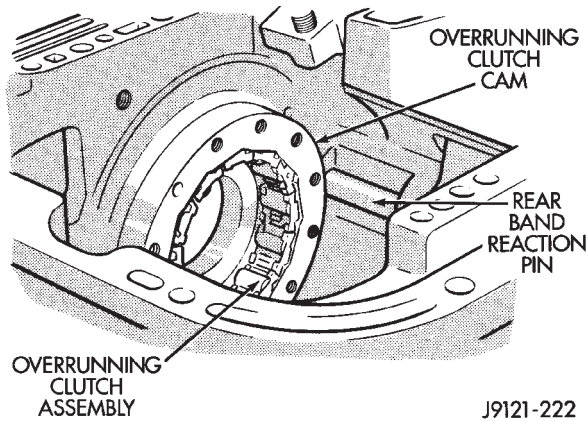


Fig. 104 Overrunning Clutch Assembly Removal

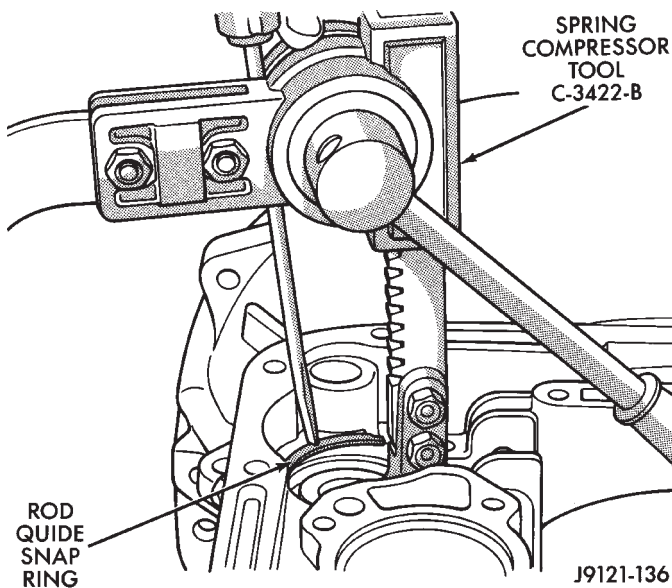


Fig. 105 Compressing Front Servo Rod Guide

(36) Compress rear servo spring retainer about 1/16 inch with Valve Spring Compressor C-3422-B (Fig. 106).

(37) Remove rear servo spring retainer snap ring. Then remove compressor tools and remove rear servo spring and piston.

(38) Inspect transmission components.

NOTE: TO SERVICE THE OVERRUNNING CLUTCH CAM OR OVERDRIVE PISTON RETAINER, REFER TO OVERRUNNING CLUTCH CAM SERVICE IN THIS SECTION.

ASSEMBLY

Do not allow dirt, grease, or foreign material to enter the case or transmission components during assembly. Keep the transmission case and components clean. Also make sure the tools and workbench area used for assembly operations are equally clean.

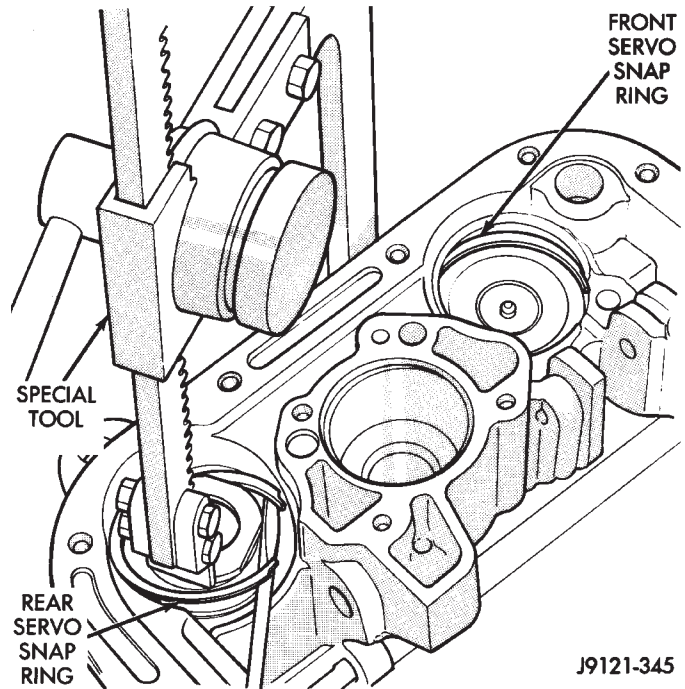


Fig. 106 Compressing Rear Servo Spring

Shop towels used for wiping off tools and hands must be made from **lint free** material. Lint will stick to transmission parts and could interfere with valve operation, or even restrict fluid passages.

Lubricate the transmission components with Mopar® transmission fluid during reassembly. Use Mopar® Door Ease, or Ru-Glyde on seals and O-rings to ease installation.

Petroleum jelly can also be used to hold thrust washers, thrust plates and gaskets in position during assembly. However, **do not** use chassis grease, bearing grease, white grease, or similar lubricants on any transmission part. These types of lubricants can eventually block or restrict fluid passages and interfere with valve operation. Use petroleum jelly only.

Do not force parts into place. The transmission components and subassemblies are easily installed by hand when properly aligned.

If a part seems extremely difficult to install, it is either misaligned or incorrectly assembled. Also verify that thrust washers, thrust plates and seal rings are correctly positioned before assembly. These parts can interfere with proper assembly if mis-positioned.

The planetary geartrain, front/rear clutch assemblies and oil pump are all much easier to install when the transmission case is upright.

(1) Install rear servo piston, spring and retainer (Fig. 107). Install spring on top of servo piston and install retainer on top of spring.

(2) Install front servo piston assembly, servo spring and rod guide (Fig. 108).

DISASSEMBLY AND ASSEMBLY (Continued)

(3) Compress front/rear servo springs with Valve Spring Compressor C-3422-B and install each servo snap ring (Fig. 109).

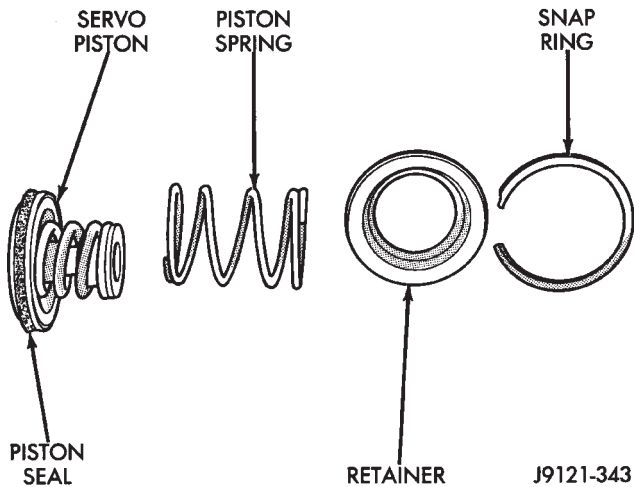


Fig. 107 Rear Servo Components

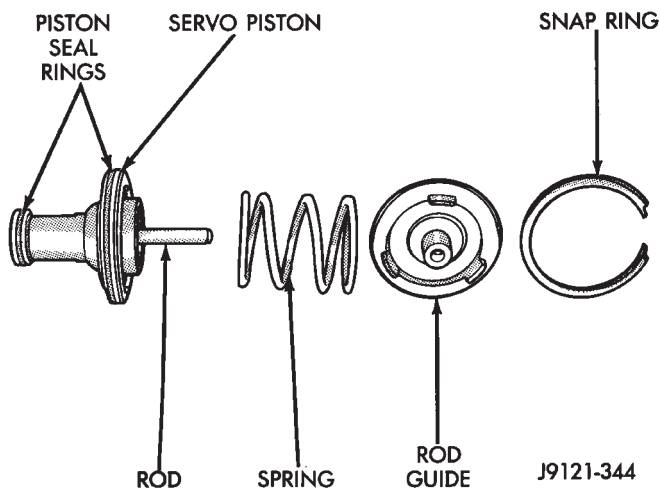


Fig. 108 Front Servo Components

(4) Lubricate clutch cam rollers with transmission fluid.

(5) Install rear band in case (Fig. 110). Be sure twin lugs on band are seated against reaction pin.

(6) Install low-reverse drum and check overrunning clutch operation as follows:

(a) Lubricate overrunning clutch race (on drum hub) with transmission fluid.

(b) Guide drum through rear band.

(c) Tilt drum slightly and start race (on drum hub) into overrunning clutch rollers.

(d) Press drum rearward and turn it in clockwise direction until drum seats in overrunning clutch (Fig. 111).

(e) Turn drum back and forth. **Drum should rotate freely in clockwise direction and lock**

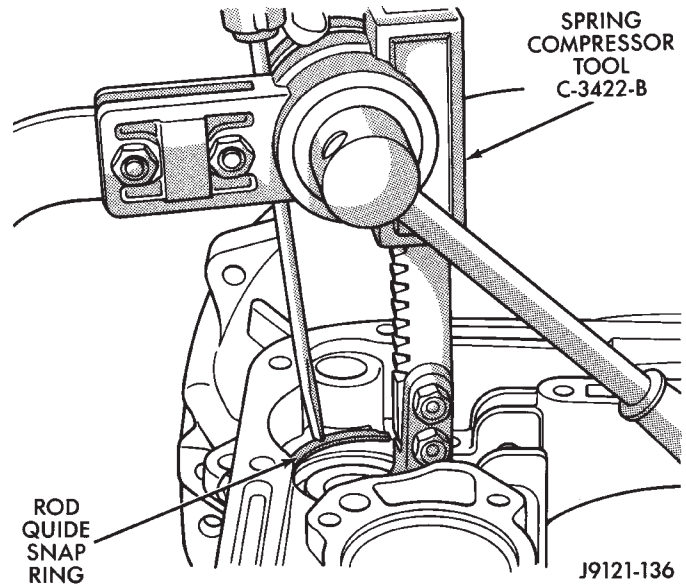


Fig. 109 Compressing Front/Rear Servo Springs

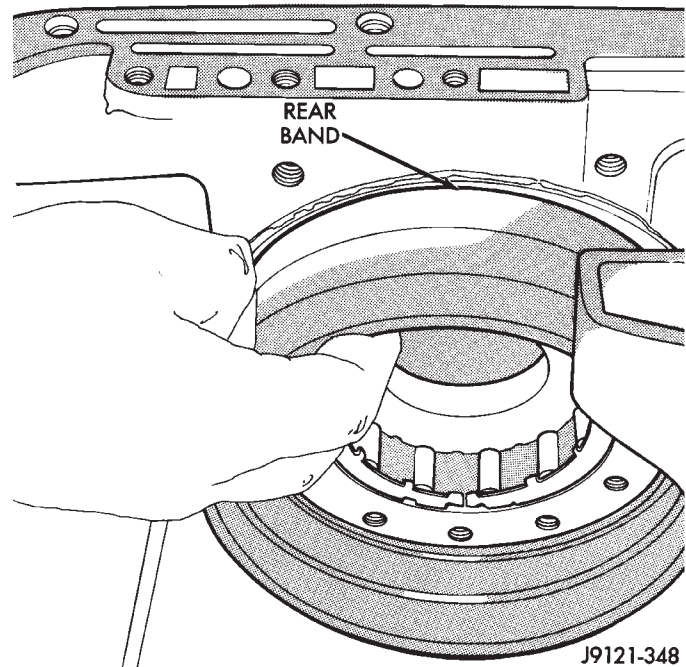


Fig. 110 Rear Band Installation

in counterclockwise direction (as viewed from front of case).

(7) Install snap ring that secures low-reverse drum to hub of overdrive piston retainer (Fig. 112).

(8) Install rear band lever and pivot pin (Fig. 113). Align lever with pin bores in case and push pivot pin into place.

(9) Install planetary geartrain assembly (Fig. 114).

(10) Install thrust plate on intermediate shaft hub (Fig. 115). Use petroleum jelly to hold thrust plate in place.

DISASSEMBLY AND ASSEMBLY (Continued)

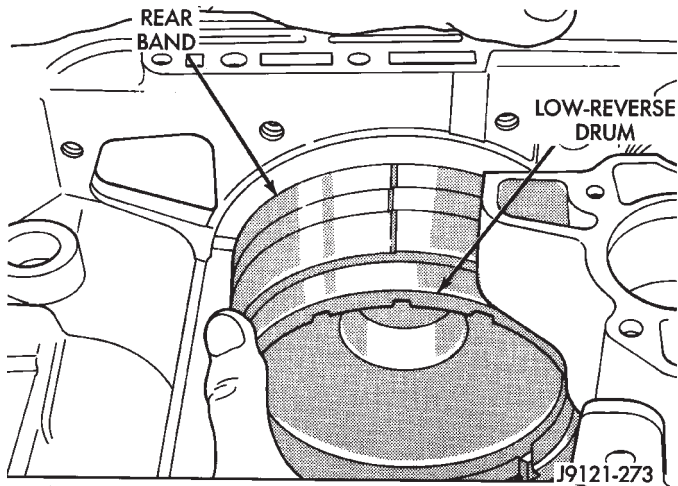


Fig. 111 Installing Low-Reverse Drum

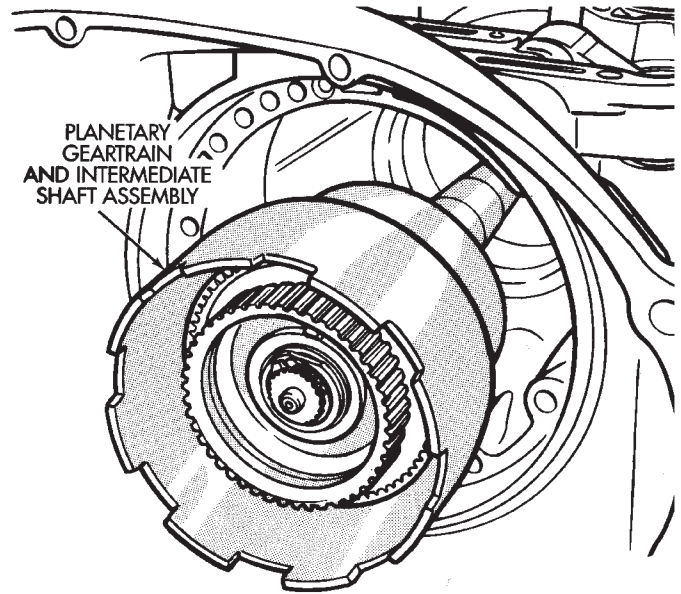


Fig. 114 Installing Planetary Geartrain

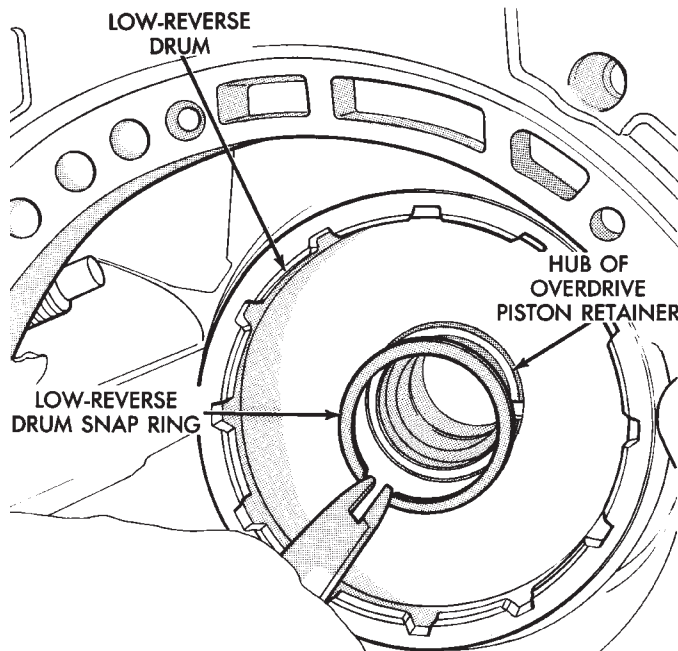


Fig. 112 Installing Low-Reverse Drum Retaining Snap Ring

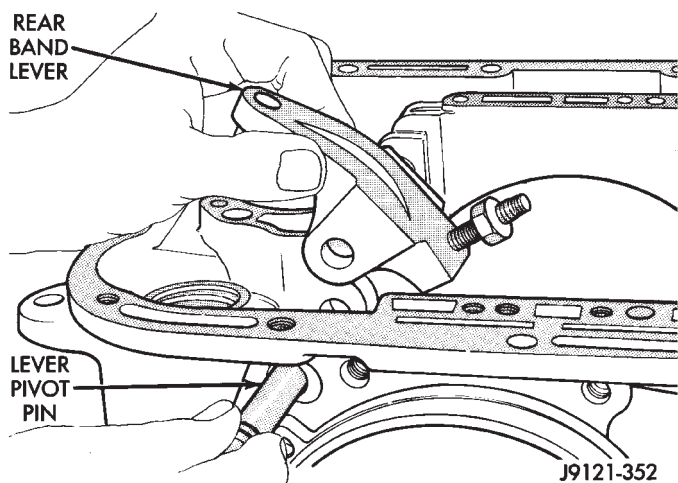


Fig. 113 Rear Band Lever And Pivot Pin Installation

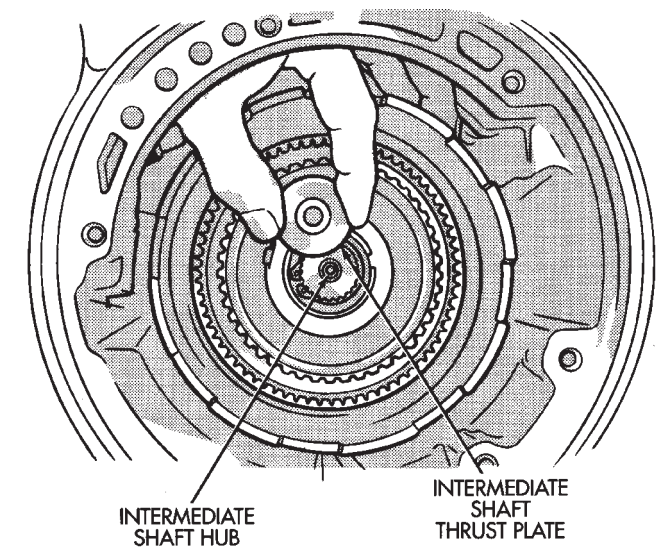


Fig. 115 Installing Intermediate Shaft Thrust Plate

place if necessary.

(13) Align clutch discs in front clutch and install front clutch on rear clutch (Fig. 118). Rotate front clutch retainer back and forth until completely seated on rear clutch retainer.

(14) Coat intermediate shaft thrust washer with petroleum jelly. Then install washer in rear clutch hub (Fig. 119). Use enough petroleum jelly to hold

DISASSEMBLY AND ASSEMBLY (Continued)

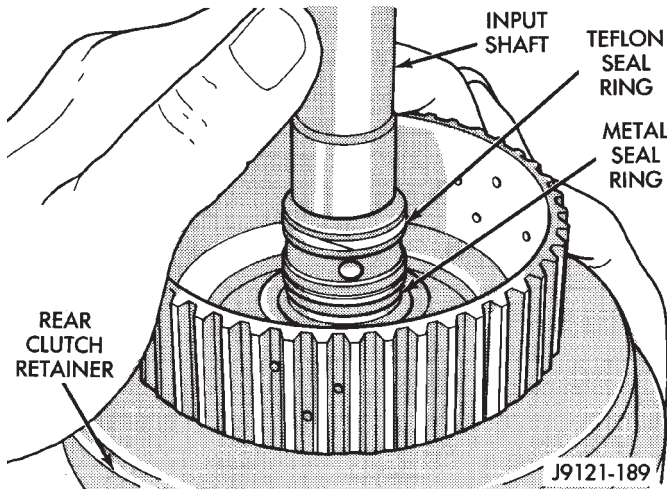


Fig. 116 Input Shaft Seal Ring Location

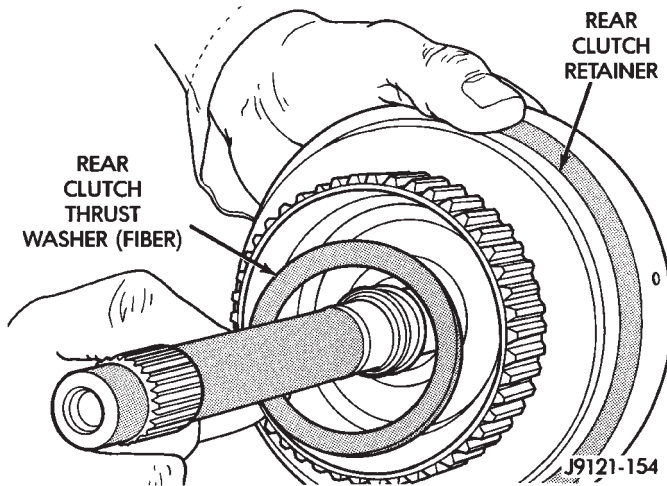


Fig. 117 Installing Rear Clutch Thrust Washer

washer in place. **Be sure grooved side of washer faces rearward (toward output shaft) as shown. Also note that washer only fits one way in clutch hub.** Note thickness of this washer. It is a select fit part and is used to control transmission end play.

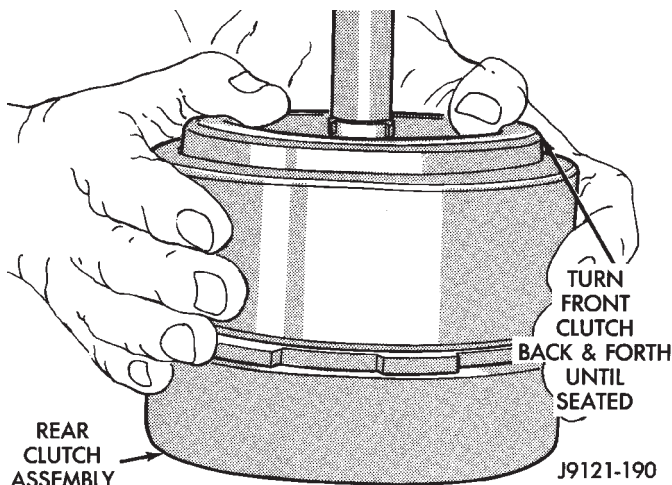


Fig. 118 Assembling Front And Rear Clutch Units

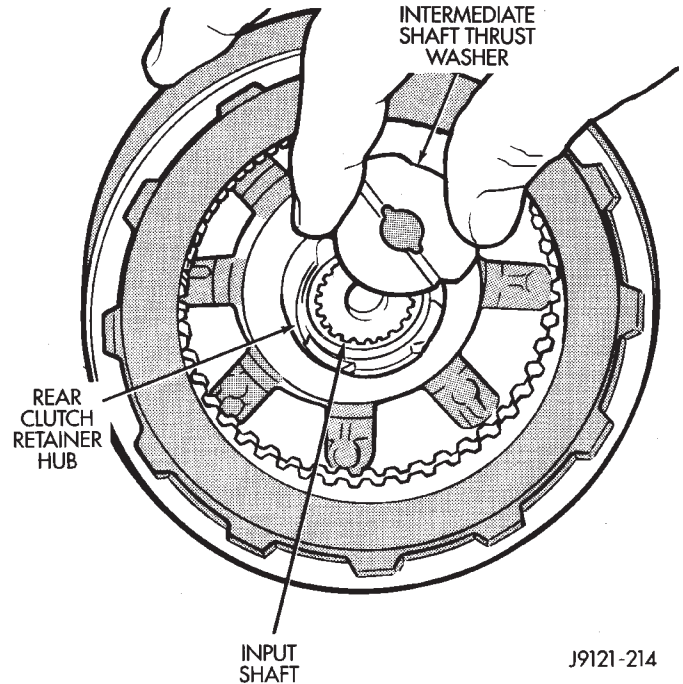


Fig. 119 Installing Intermediate Shaft Thrust Plate

(15) Align drive teeth on rear clutch discs with small screwdriver (Fig. 120). This makes installation on front planetary easier.

(16) Raise front end of transmission upward as far as possible and support case with wood blocks. Front/rear clutch and oil pump assemblies are easier to install if transmission is as close to upright position as possible.

(17) Slide front band into case.

(18) Install front and rear clutch units as assembly (Fig. 121). Align rear clutch with front annulus gear and install assembly in driving shell. **Be sure output shaft thrust washer and thrust plate are not displaced during installation.**

(19) Carefully work assembled clutches back and forth to engage and seat rear clutch discs on front annulus gear. Also be sure front clutch drive lugs are fully engaged in slots of driving shell after installation.

(20) Assemble front band strut.

(21) Install front band adjuster, strut and adjusting screw (Fig. 122).

(22) Tighten band adjusting screw until band just grips clutch retainer. Verify that front/rear clutches are still seated before continuing.

(23) Check seal rings on reaction shaft support hub. Verify that seal rings are hooked together and that front clutch thrust washer is properly positioned (Fig. 123). Use petroleum jelly to hold thrust washer in place if necessary.

(24) Lubricate oil pump body seal with petroleum jelly. Lubricate pump shaft seal lip with petroleum jelly.

DISASSEMBLY AND ASSEMBLY (Continued)

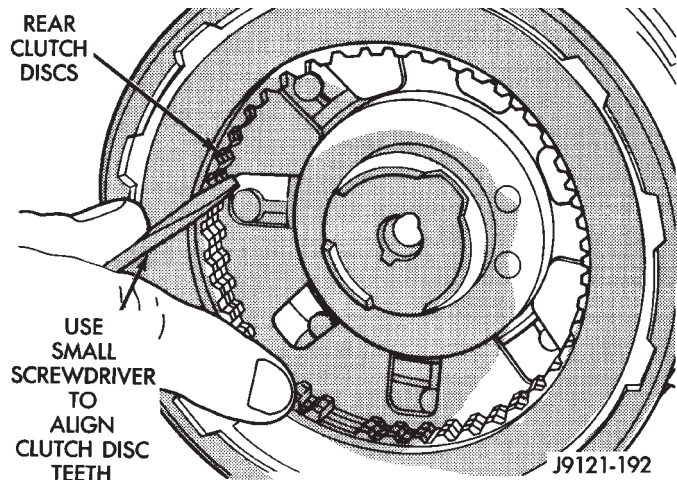


Fig. 120 Aligning Rear Clutch Disc Lugs

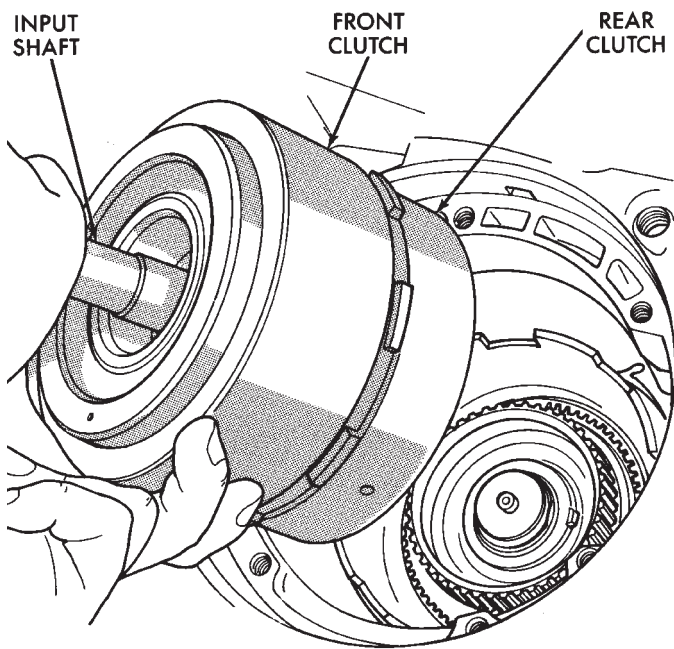


Fig. 121 Installing Front/Rear Clutch Assemblies

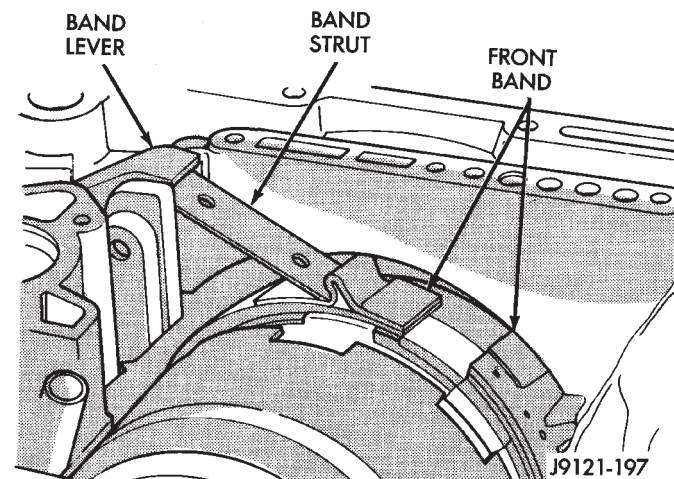


Fig. 122 Front Band Linkage Installation

- (25) Thread two Pilot Stud Tools C-3288-B into bolt holes in oil pump bore flange (Fig. 124).
- (26) Align and install oil pump gasket (Fig. 124).

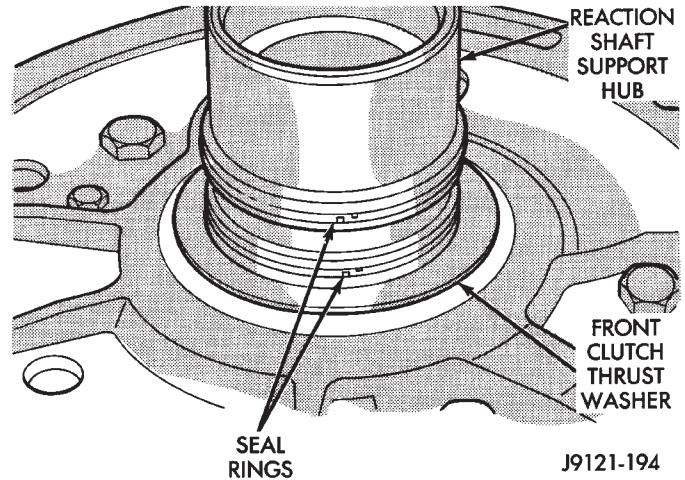


Fig. 123 Reaction Shaft Support Seal Rings And Front Clutch Thrust Washer

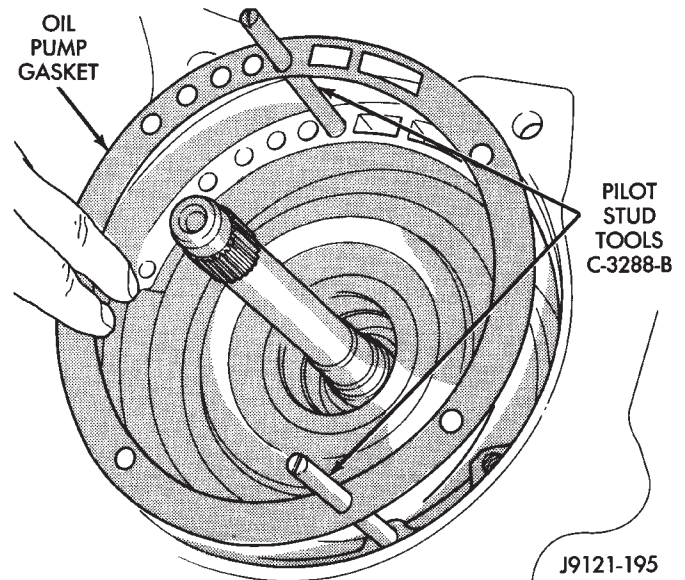


Fig. 124 Installing Pilot Studs And Oil Pump Gasket

- (27) Install oil pump (Fig. 125). Align and position pump on pilot studs. Slide pump down studs and work it into front clutch hub and case by hand. Then install 2 or 3 pump bolts to hold pump in place.
- (28) Remove pilot stud tools and install remaining oil pump bolts. Tighten bolts alternately in diagonal pattern to 20 N·m (15 ft. lbs.).
- (29) Measure and if necessary, correct input shaft end play as follows (Fig. 126):
 - (a) Attach dial indicator to converter housing.
 - (b) Position indicator plunger against input shaft and zero indicator.
 - (c) Move input shaft in and out and record reading. End play should be 0.56 - 2.31 mm (0.022 -

DISASSEMBLY AND ASSEMBLY (Continued)

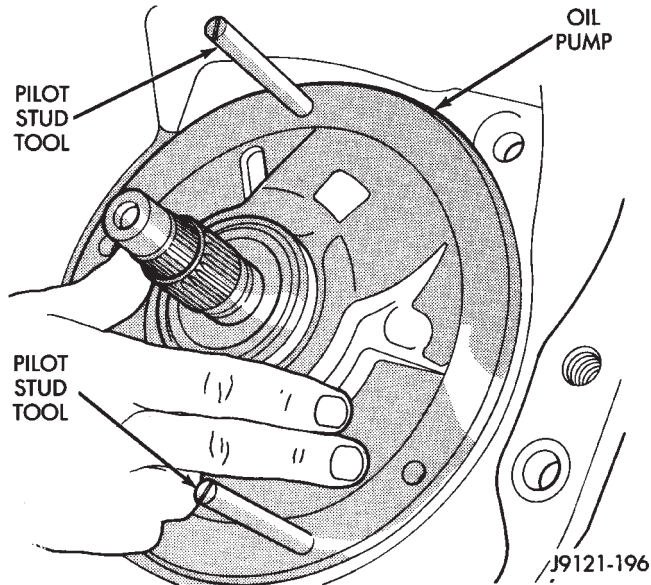


Fig. 125 Installing Oil Pump Assembly In Case

0.091 in.). Proceed to next step if end play is not within specified limits.

(d) Intermediate shaft thrust washer (in hub of rear clutch retainer) controls end play. Washer is a select fit part and can be changed to adjust end play. If end play turns out to be incorrect, remove oil pump, and clutches. Then install thinner/thicker thrust washer as necessary.

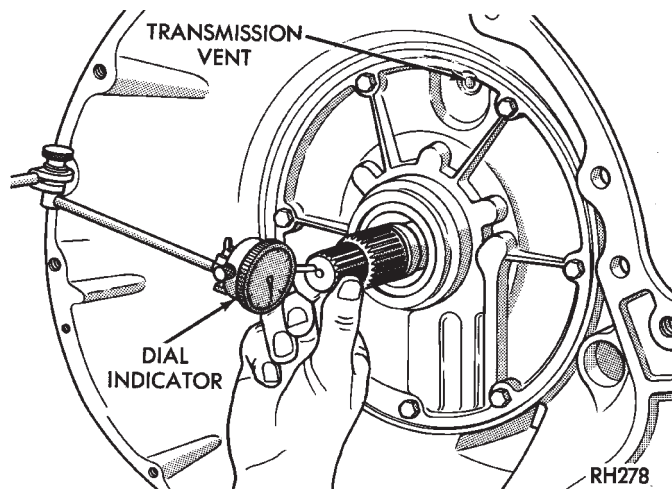


Fig. 126 Measuring Input Shaft End Play

(30) Install accumulator piston and inner and outer springs (Fig. 127).

(31) Verify that valve body solenoid harness is secured in 3-4 accumulator housing cover plate.

(32) Install valve body as follows:

(a) Align and carefully insert park rod into pawl. Rod will make click noise as it enters pawl. Move rod slightly to check engagement.

(b) Align and seat valve body on case. Be sure manual lever shaft and overdrive connector are

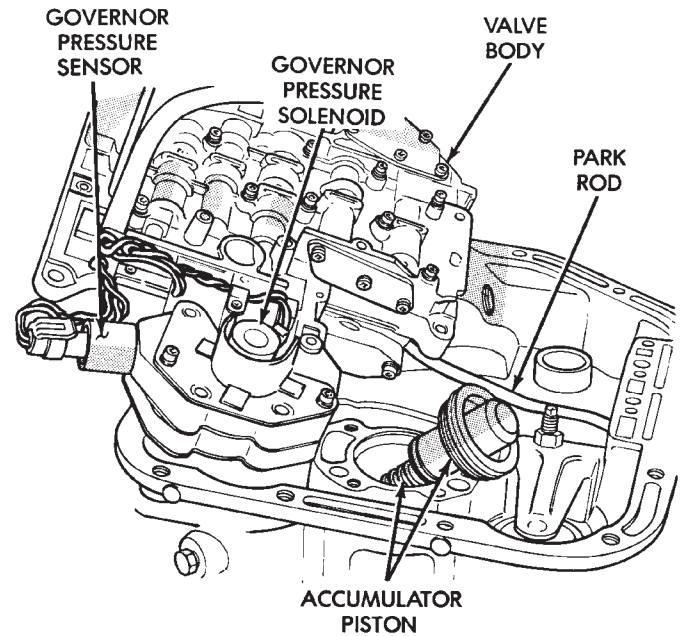


Fig. 127 Accumulator Piston And Springs

fully seated in case. Also be sure valve body wiring is not pinched or kinked.

(c) Install and start all valve body attaching bolts by hand. Then tighten bolts evenly, in a diagonal pattern to 12 N·m (105 in. lbs.) torque. **Do not overtighten valve body bolts. This could result in distortion and cross leakage after installation..**

CAUTION: It is possible for the park rod to displace into a cavity just above the pawl sprag during installation. Make sure the rod is actually engaged in the pawl and has not displaced into the cavity.

(33) Install new filter on valve body. Tighten filter screws to 4 N·m (35 in. lbs.).

(34) Adjust front and rear bands.

(35) Install seal on park/neutral position switch (Fig. 128). Then install and tighten switch to 34 N·m (25 ft. lbs.).

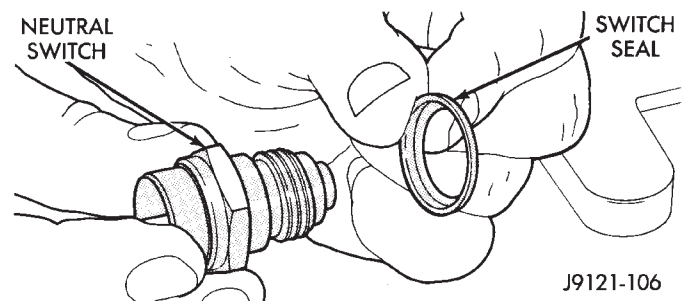


Fig. 128 Park/Neutral Position Switch Seal Position

(36) Install magnet in oil pan. Magnet goes on small protrusion at corner of pan.

DISASSEMBLY AND ASSEMBLY (Continued)

(37) Position new oil pan gasket on case and install oil pan. Tighten pan bolts to 17 N-m (13 ft. lbs.).

(38) Install new valve body manual shaft seal in case (Fig. 129). Lubricate seal lip and manual shaft with petroleum jelly. Start seal over shaft and into case. Seat seal with 15/16 inch, deep well socket.

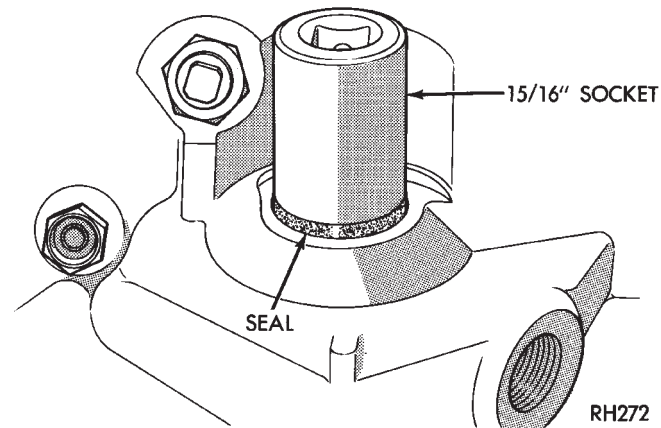


Fig. 129 Installing Manual Lever Shaft Seal

(39) Install throttle valve and shift selector levers on valve body manual lever shaft.

OVERRUNNING CLUTCH CAM/OVERDRIVE PISTON RETAINER

DISASSEMBLY

NOTE: TO SERVICE THE OVERRUNNING CLUTCH CAM AND THE OVERDRIVE PISTON RETAINER, THE TRANSMISSION GEARTRAIN AND OVERDRIVE UNIT MUST BE REMOVED FROM THE TRANSMISSION.

- (1) Remove the overdrive piston (Fig. 130).
- (2) Remove the overdrive piston retainer bolts.
- (3) Remove overdrive piston retainer.
- (4) Remove case gasket.
- (5) Mark the position of the overrunning clutch cam in the case (Fig. 131).
- (6) Remove the overrunning clutch cam bolts.
- (7) Remove the overrunning clutch cam.

ASSEMBLY

- (1) Examine bolt holes in overrunning clutch cam. Note that one hole is **not threaded** (Fig. 132). This hole must align with blank area in clutch cam bolt circle (Fig. 133). Mark hole location on clutch cam and blank area in case with grease pencil, paint stripe, or scribe mark for assembly reference.
- (2) Mark location of non-threaded hole in clutch cam and blank area in bolt circle with grease pencil.
- (3) Align and install overrunning clutch and cam in case (Fig. 134). **Be sure cam is correctly installed. Bolt holes in cam are slightly counter-sunk on one side. Be sure this side of cam faces rearward (toward piston retainer).**

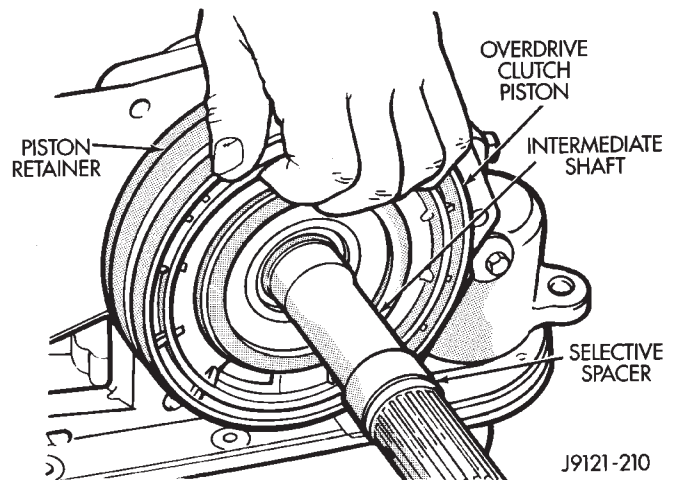


Fig. 130 Overdrive Piston Removal

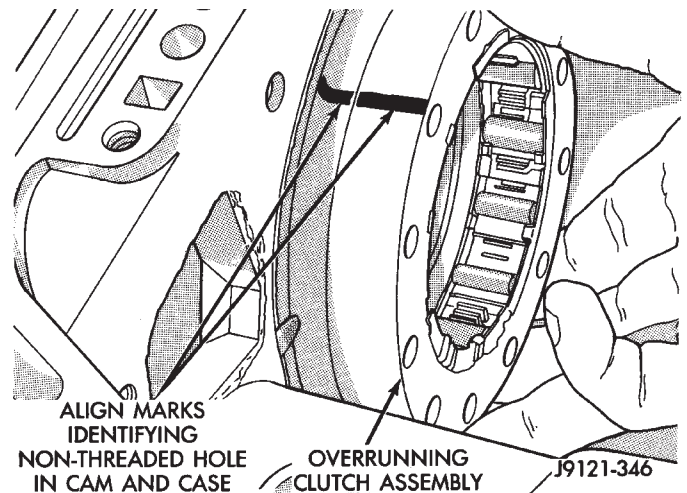


Fig. 131 Overrunning Clutch Cam Removal

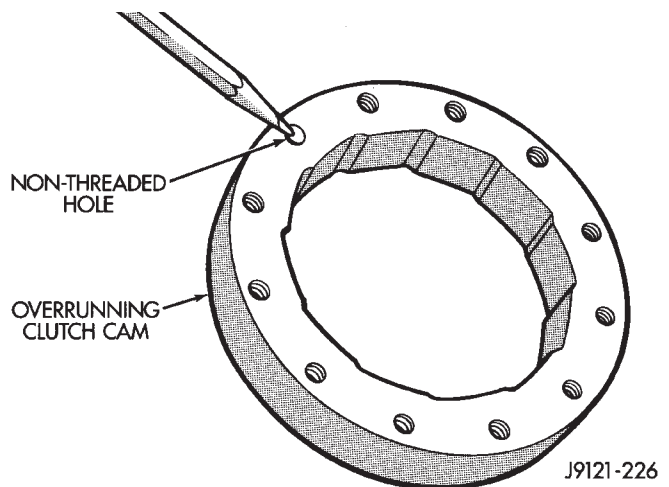
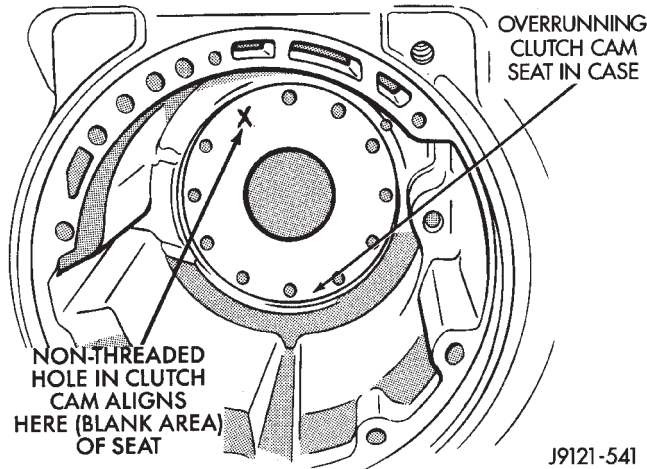


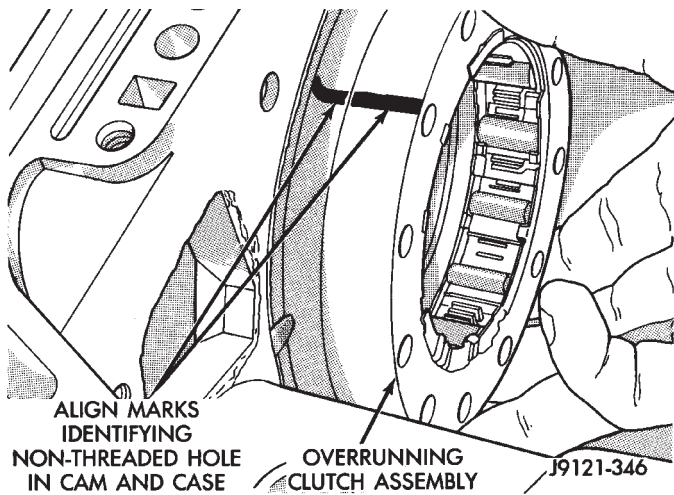
Fig. 132 Location Of Non-Threaded Hole In Clutch Cam

DISASSEMBLY AND ASSEMBLY (Continued)



J9121-541

Fig. 133 Location Of Blank Area In Clutch Cam Bolt Circle



J9121-346

Fig. 134 Overrunning Clutch Installation

(4) Verify that non-threaded hole in clutch cam is properly aligned. Check alignment by threading a bolt into each bolt hole. Adjust clutch cam position if necessary.

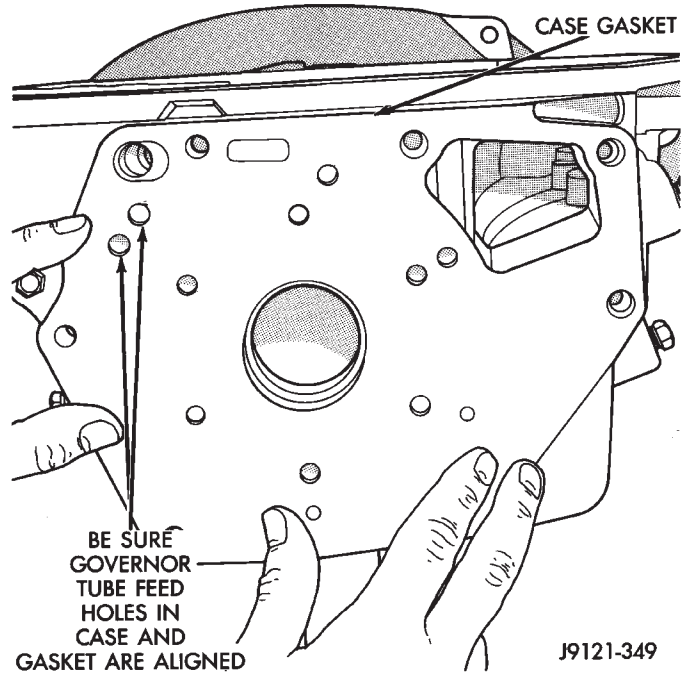
(5) Install and tighten overrunning clutch cam bolts to 17 N·m (13 ft. lbs.) torque. Note that clutch cam bolts are shorter than piston retainer bolts.

(6) Install new gasket at rear of transmission case. Use petroleum jelly to hold gasket in place. Be sure to align governor feed holes in gasket with feed passages in case (Fig. 135). Also install gasket before overdrive piston retainer. Center hole in gasket is smaller than retainer and cannot be installed over retainer.

(7) Position overdrive piston retainer on transmission case and align bolt holes in retainer, gasket and case (Fig. 136). Then install and tighten retainer bolts to 17 N·m (13 ft. lbs.) torque.

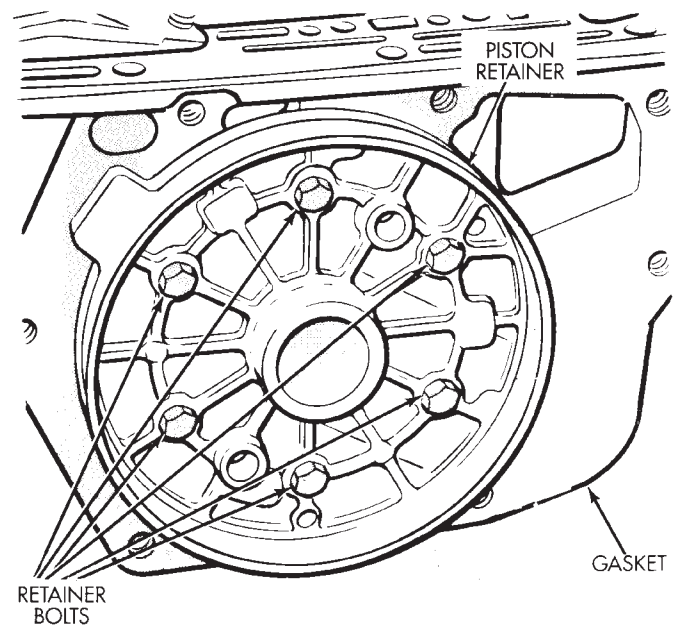
(8) Install new seals on over drive piston.

(9) Stand transmission case upright on bellhousing.



J9121-349

Fig. 135 Installing/Aligning Case Gasket



J9321-464

Fig. 136 Aligning Overdrive Piston Retainer

(10) Position Guide Ring 8114-1 on outer edge of overdrive piston retainer.

(11) Position Seal Guide 8114-2 on inner edge of overdrive piston retainer.

(12) Install overdrive piston in overdrive piston retainer by: aligning locating lugs on overdrive piston to the two mating holes in retainer.

(a) Aligning locating lugs on overdrive piston to the two mating holes in retainer.

DISASSEMBLY AND ASSEMBLY (Continued)

- (b) Lubricate overdrive piston seals with Mopar® Door Ease, or equivalent.
- (c) Install piston over Seal Guide 8114-2 and inside Guide Ring 8114-1.
- (d) Push overdrive piston into position in retainer.
- (e) Verify that the locating lugs entered the lug bores in the retainer.

NOTE: INSTALL THE REMAINING TRANSMISSION COMPONENTS AND OVERDRIVE UNIT.

FRONT SERVO PISTON

DISASSEMBLY

- (1) Remove seal ring from rod guide (Fig. 137).
- (2) Remove small snap ring from servo piston rod. Then remove piston rod, spring and washer from piston.
- (3) Remove and discard servo component O-ring and seal rings.

ASSEMBLY

- Clean and inspect front servo components.
- (1) Lubricate new O-ring and seal rings with petroleum jelly and install them on piston, guide and rod.
 - (2) Install rod in piston. Install spring and washer on rod. Compress spring and install snap ring (Fig. 137).
 - (3) Set servo components aside for installation during transmission reassembly.

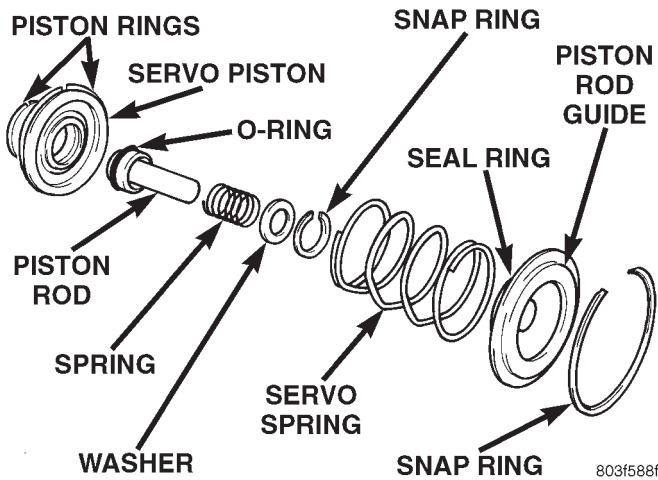


Fig. 137 Front Servo

REAR SERVO PISTON

DISASSEMBLY

- (1) Remove small snap ring and remove plug and spring from servo piston (Fig. 138).
- (2) Remove and discard servo piston seal ring.

ASSEMBLY

- (1) Lubricate piston and guide seals with petroleum jelly. Lubricate other servo parts with Mopar® ATF Plus 3, Type 7176, transmission fluid.
- (2) Install new seal ring on servo piston.
- (3) Assemble piston, plug, spring and new snap ring.
- (4) Lubricate piston seal lip with petroleum jelly.

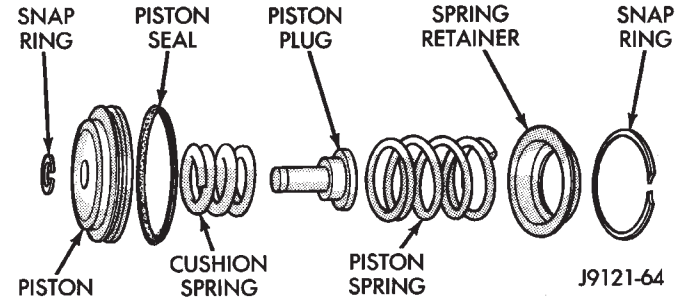


Fig. 138 Rear Servo Components

OIL PUMP AND REACTION SHAFT SUPPORT

DISASSEMBLY

- (1) Remove seal ring from housing and reaction shaft support (Fig. 139).
- (2) Mark pump housing and support assembly for alignment reference.
- (3) Remove bolts attaching pump body to support (Fig. 140).

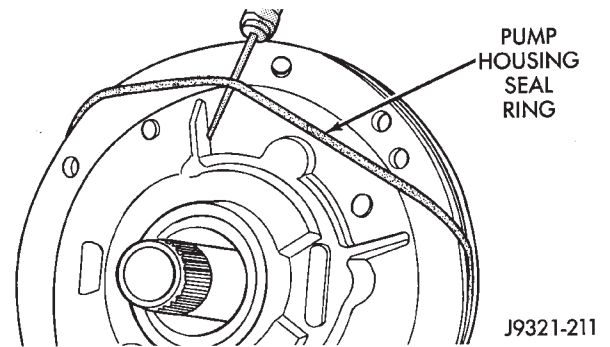
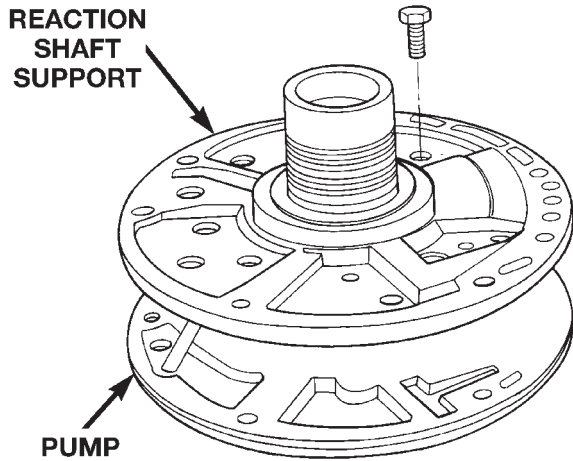


Fig. 139 Removing Pump Seal Ring

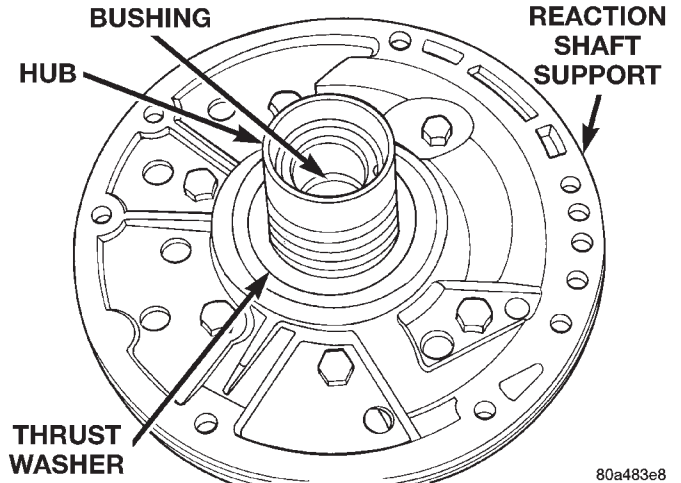
- (4) Separate support from pump housing (Fig. 141).
- (5) Remove inner and outer gears from reaction shaft support (Fig. 142).
- (6) If pump seal was not removed during transmission disassembly, remove seal with punch and hammer.
- (7) Remove front clutch thrust washer from support hub (Fig. 143).

DISASSEMBLY AND ASSEMBLY (Continued)



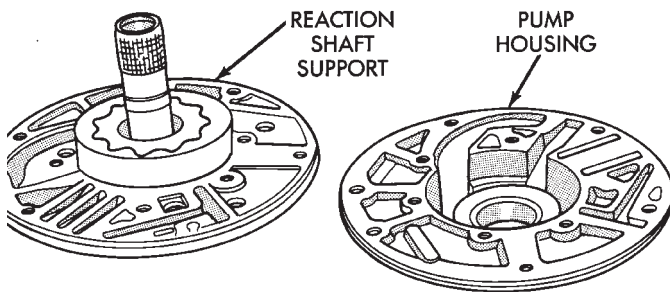
80a483e7

Fig. 140 Pump Support Bolts



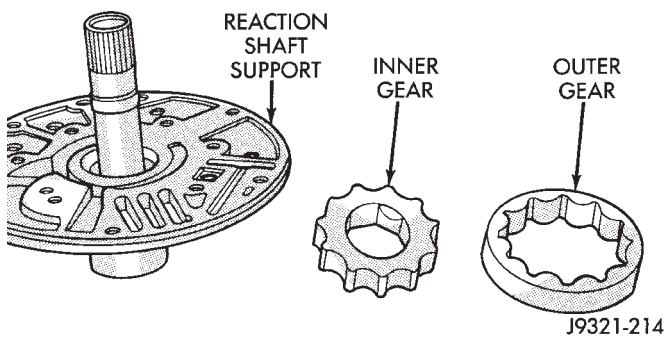
80a483e8

Fig. 143 Support Hub Thrust Washer



J9321-213

Fig. 141 Separating Pump Housing From Reaction Shaft Support



J9321-214

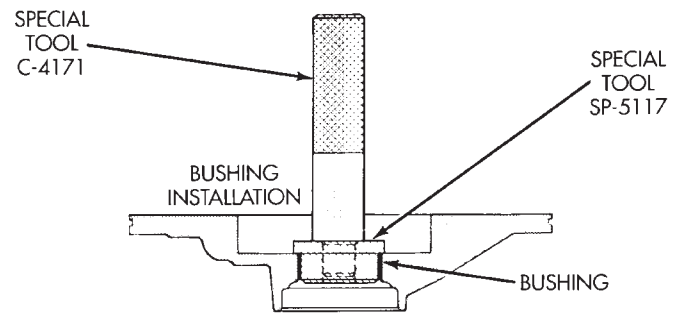
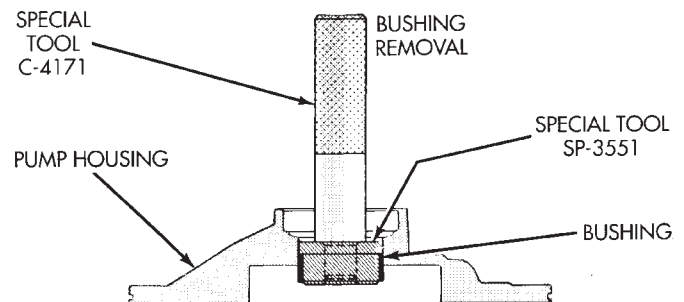
Fig. 142 Pump Gear Removal

OIL PUMP BUSHING REPLACEMENT

(1) Remove pump bushing with Tool Handle C-4171 and Bushing Remover SP-3551 from Tool Set C-3887-J (Fig. 144).

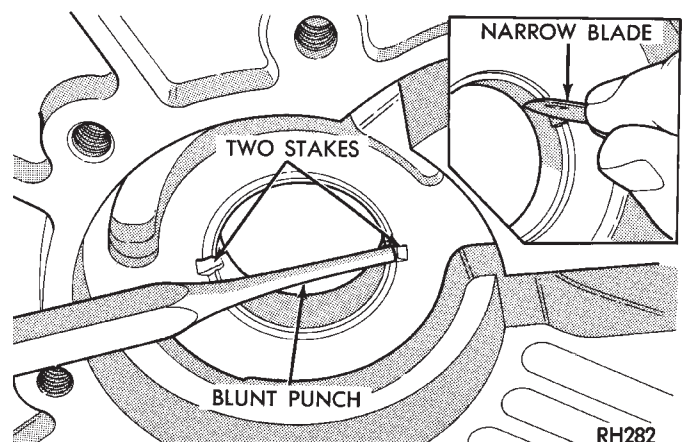
(2) Install new pump bushing with Tool Handle C-4171 and Bushing Installer SP-5117 (Fig. 144). Bushing should be flush with pump housing bore.

(3) Stake new pump bushing in two places with blunt punch (Fig. 145). Remove burrs from stake points with knife blade afterward.



J9221-242

Fig. 144 Removing Oil Pump Bushing



RH282

Fig. 145 Staking Oil Pump Bushing

DISASSEMBLY AND ASSEMBLY (Continued)

REACTION SHAFT SUPPORT BUSHING REMOVAL

- (1) Assemble Bushing Remover Tools SP-1191, 3633 and 5324 (Fig. 146). **Do not clamp any part of reaction shaft or support in vise.**
- (2) Hold Cup Tool SP-3633 firmly against reaction shaft and thread remover SP-5324 into bushing as far as possible by hand. Then thread remover tool 3-4 additional turns into bushing with a wrench.
- (3) Turn remover tool hex nut down against remover cup to pull bushing from shaft. Clean all chips from shaft after bushing removal.
- (4) Lightly grip old bushing in vise or with pliers and back remover tool out of bushing.
- (5) Assemble Bushing Installer Tools C-4171 and SP-5325 (Fig. 146).
- (6) Slide new bushing onto Installer Tool SP-5325.
- (7) Position reaction shaft support upright on a clean smooth surface.
- (8) Align bushing in bore. Then tap bushing into place until Bushing Installer SP-5325 bottoms.
- (9) Clean reaction shaft support thoroughly after installing bushing.

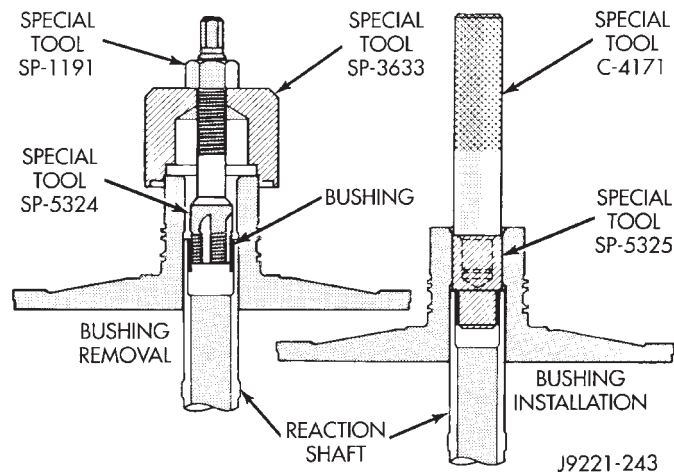


Fig. 146 Replacing Reaction Shaft Support Bushing ASSEMBLY

- (1) Lubricate gear bore in pump housing with transmission fluid.
- (2) Lubricate pump gears with transmission fluid.
- (3) Support pump housing on wood blocks (Fig. 147).
- (4) Install outer gear in pump housing (Fig. 147). Gear can be installed either way (it is not a one-way fit).
- (5) Install pump inner gear (Fig. 148).

CAUTION: The pump inner gear is a one way fit. The bore on one side of the gear inside diameter (I.D.) is chamfered. Be sure the chamfered side faces forward (to front of pump).

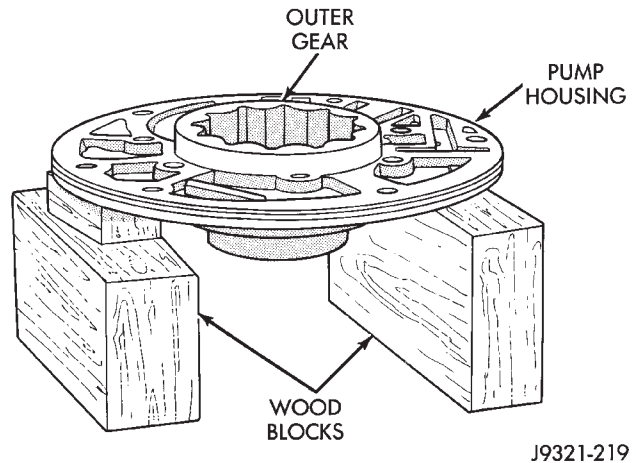


Fig. 147 Supporting Pump And Installing Outer Gear

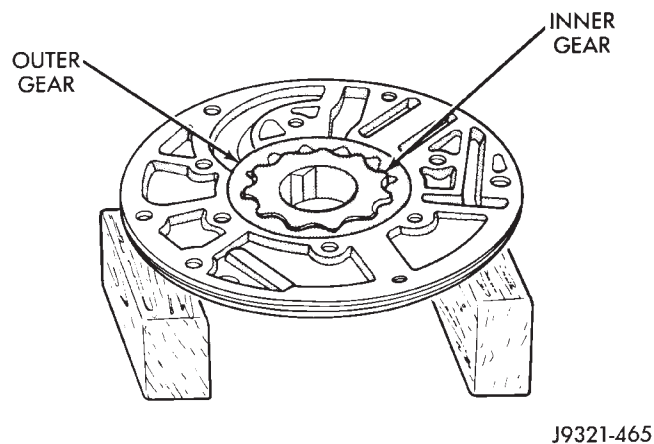


Fig. 148 Pump Inner Gear Installation

- (6) Install new thrust washer on hub of reaction shaft support. Lubricate washer with transmission fluid or petroleum jelly.
- (7) If reaction shaft seal rings are being replaced, install new seal rings on support hub (Fig. 149). Lubricate seal rings with transmission fluid or petroleum jelly after installation. Squeeze each ring until ring ends are securely hooked together.

CAUTION: The reaction shaft support seal rings will break if overspread, or twisted. If new rings are being installed, spread them only enough for installation. Also be very sure the ring ends are securely hooked together after installation. Otherwise, the rings will either prevent pump installation, or break during installation.

- (8) Install reaction shaft support on pump housing (Fig. 150).
- (9) Align reaction support on pump housing. Use alignment marks made at disassembly. Or, rotate

DISASSEMBLY AND ASSEMBLY (Continued)

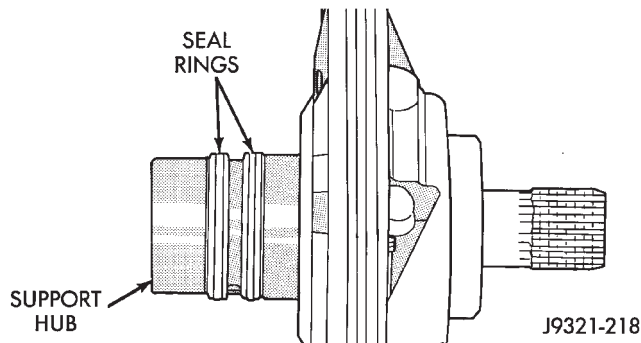


Fig. 149 Hub Seal Ring Position

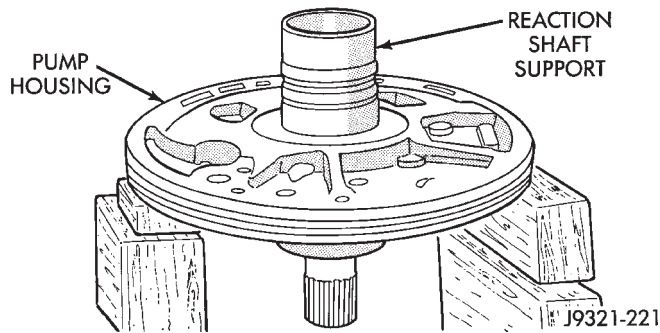


Fig. 150 Assembling Reaction Shaft Support And Pump Housing

support until bolt holes in support and pump housing are all aligned (holes are offset for one-way fit).

(10) Install all bolts that attach support to pump housing. Then tighten bolts finger tight.

(11) Tighten support-to-pump bolts to required torque as follows:

(a) Reverse pump assembly and install it in transmission case. Position pump so bolts are facing out and are accessible.

(b) Secure pump assembly in case with 2 or 3 bolts, or with pilot studs.

(c) Tighten support-to-pump bolts to 20 N·m (15 ft. lbs.).

(d) Remove pump assembly from transmission case.

(12) Install new oil seal in pump with Special Tool C-4193 and Tool Handle C-4171 (Fig. 151). Be sure seal lip faces inward.

(13) Install new seal ring around pump housing. Be sure seal is properly seated in groove.

(14) Lubricate lip of pump oil seal and O-ring seal with transmission fluid.

FRONT CLUTCH

NOTE: The 42RE transmission uses four plates and discs for the front clutch. The 44RE uses five plates and discs for the front clutch. The front clutch retainer is not interchangeable between these transmissions.

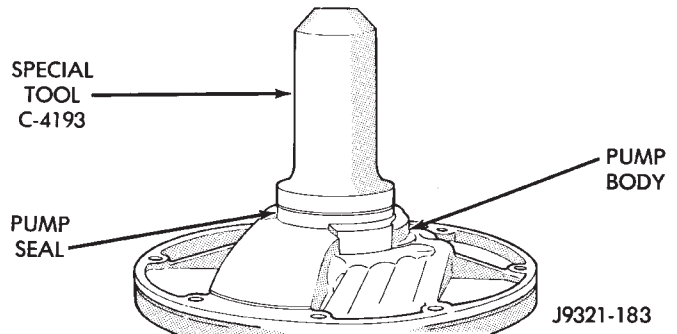


Fig. 151 Pump Oil Seal Installation

DISASSEMBLY

(1) Remove waved snap ring and remove pressure plate, clutch plates and clutch discs (Fig. 152).

(2) Compress clutch piston spring with Compressor Tool C-3575-A (Fig. 153). Be sure legs of tool are seated squarely on spring retainer before compressing spring.

(3) Remove retainer snap ring and remove compressor tool.

(4) Remove spring retainer and clutch spring. Note position of retainer on spring for assembly reference.

(5) Remove clutch piston from clutch retainer. Remove piston by rotating it up and out of retainer.

(6) Remove seals from clutch piston and clutch retainer hub. Discard both seals as they are not reusable.

ASSEMBLY

(1) Soak clutch discs in transmission fluid while assembling other clutch parts.

(2) Install new seals on piston and in hub of retainer. Be sure lip of each seal faces interior of clutch retainer.

(3) Lubricate lips of piston and retainer seals with liberal quantity of Mopar® Door Ease. Then lubricate retainer hub, bore and piston with light coat of transmission fluid.

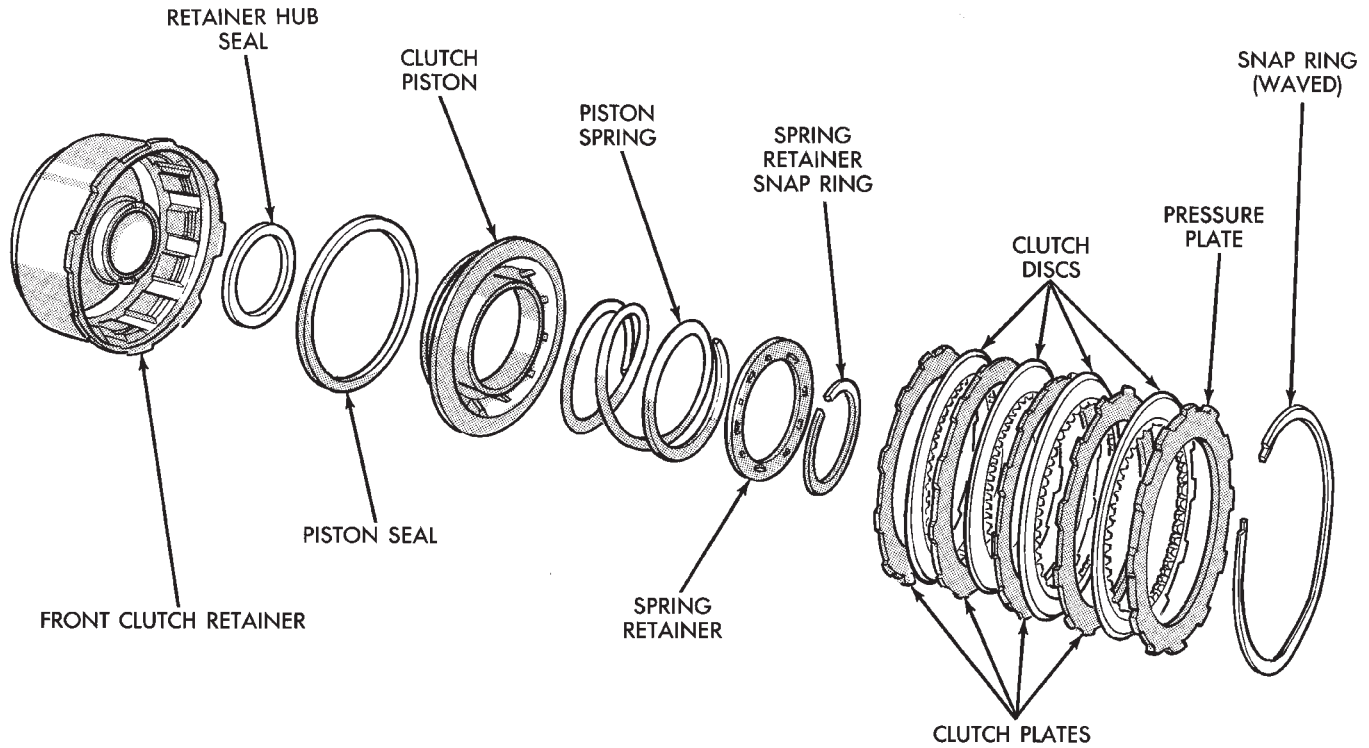
(4) Install clutch piston in retainer (Fig. 154). Use twisting motion to seat piston in bottom of retainer.

CAUTION: Never push the clutch piston straight in. This will fold the seals over causing leakage and clutch slip.

(5) Position spring in clutch piston (Fig. 155).

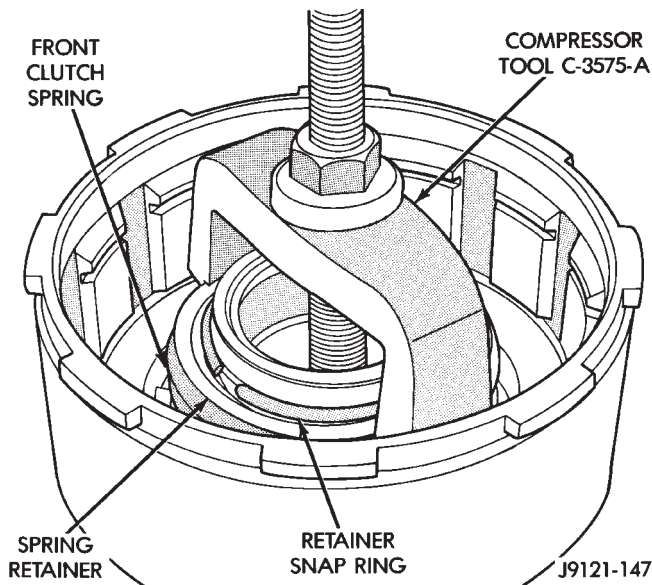
(6) Position spring retainer on top of piston spring (Fig. 156). **Make sure retainer is properly installed. Small raised tabs should be facing upward. Semicircular lugs on underside of retainer are for positioning retainer in spring.**

DISASSEMBLY AND ASSEMBLY (Continued)



J9321-222

Fig. 152 42RE Front Clutch Components

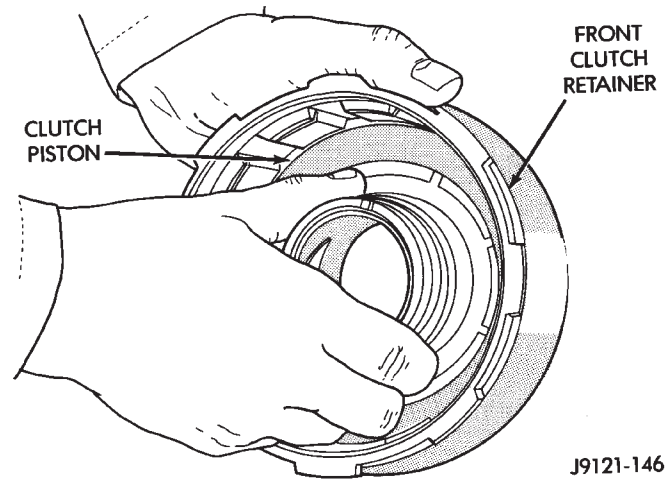


J9121-147

Fig. 153 Compressing Front Clutch Piston Spring

(7) Compress piston spring and retainer with Compressor Tool C-3575-A (Fig. 153). Then install new snap ring to secure spring retainer and spring.

(8) Install clutch plates and discs (Fig. 152). Install steel plate then disc until all plates and discs are installed. The front clutch uses 4 clutch discs and



J9121-146

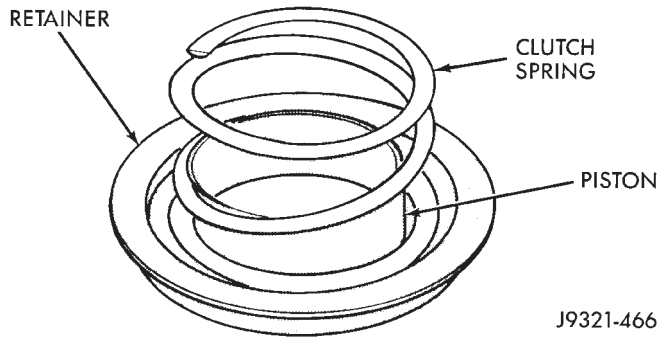
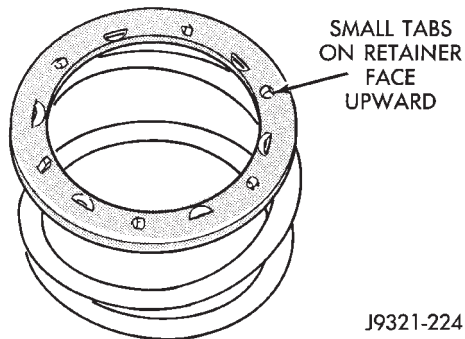
Fig. 154 Front Clutch Piston Installation

plates in a 42RE transmission. In a 44RE transmission 5 discs and plates are used.

(9) Install pressure plate and waved snap ring (Fig. 152).

Front clutch clearance specifications for the 42RE and 44RE transmission are the same.

Clearance should be 1.70 to 3.40 mm (0.067 to 0.134 in.). If clearance is incorrect, clutch discs, plates, pressure plates and snap ring may have to be changed.

DISASSEMBLY AND ASSEMBLY (Continued)**Fig. 155 Clutch Piston Spring Installation****Fig. 156 Correct Spring Retainer Installed Position****REAR CLUTCH****DISASSEMBLY**

- (1) Remove fiber thrust washer from forward side of clutch retainer.
- (2) Remove input shaft front/rear seal rings.
- (3) Remove selective clutch pack snap ring (Fig. 157).
- (4) Remove top pressure plate, clutch discs, steel plates, bottom pressure plate and wave snap ring and wave spring (Fig. 157).
- (5) Remove clutch piston with rotating motion.
- (6) Remove and discard piston seals.
- (7) Remove input shaft snap-ring (Fig. 158). It may be necessary to press the input shaft in slightly to relieve tension on the snap-ring.
- (8) Press input shaft out of retainer with shop press and suitable size press tool. Use a suitably sized press tool to support the retainer as close to the input shaft as possible.

ASSEMBLY

- (1) Soak clutch discs in transmission fluid while assembling other clutch parts.
- (2) Install new seal rings on clutch retainer hub and input shaft if necessary (Fig. 159).
 - (a) Be sure clutch hub seal ring is fully seated in groove and is not twisted.
- (3) Lubricate splined end of input shaft and clutch retainer with transmission fluid. Then press input

shaft into retainer. Use a suitably sized press tool to support retainer as close to input shaft as possible.

- (4) Install input shaft snap-ring (Fig. 158).
- (5) Invert retainer and press input shaft in opposite direction until snap-ring is seated.
- (6) Install new seals on clutch piston. Be sure lip of each seal faces interior of clutch retainer.
- (7) Lubricate lip of piston seals with generous quantity of Mopar® Door Ease. Then lubricate retainer hub and bore with light coat of transmission fluid.
- (8) Install clutch piston in retainer. Use twisting motion to seat piston in bottom of retainer. A thin strip of plastic (about 0.020" thick), can be used to guide seals into place if necessary.

CAUTION: Never push the clutch piston straight in. This will fold the seals over causing leakage and clutch slip. In addition, never use any type of metal tool to help ease the piston seals into place. Metal tools will cut, shave, or score the seals.

- (9) Install piston spring in retainer and on top of piston (Fig. 162). Concave side of spring faces downward (toward piston).
- (10) Install wave spring in retainer (Fig. 162). Be sure spring is completely seated in retainer groove.
- (11) Install bottom pressure plate (Fig. 157). Ridged side of plate faces downward (toward piston) and flat side toward clutch pack.
- (12) Install first clutch disc in retainer on top of bottom pressure plate. Then install a clutch plate followed by a clutch disc until entire clutch pack is installed (4 discs and 3 plates are required) (Fig. 157).
- (13) Install top pressure plate.
- (14) Install selective snap ring. Be sure snap ring is fully seated in retainer groove.
- (15) Using a suitable gauge bar and dial indicator, measure clutch pack clearance (Fig. 163).

- (a) Position gauge bar across the clutch drum with the dial indicator pointer on the pressure plate (Fig. 163).

- (b) Using two small screw drivers, lift the pressure plate and release it.

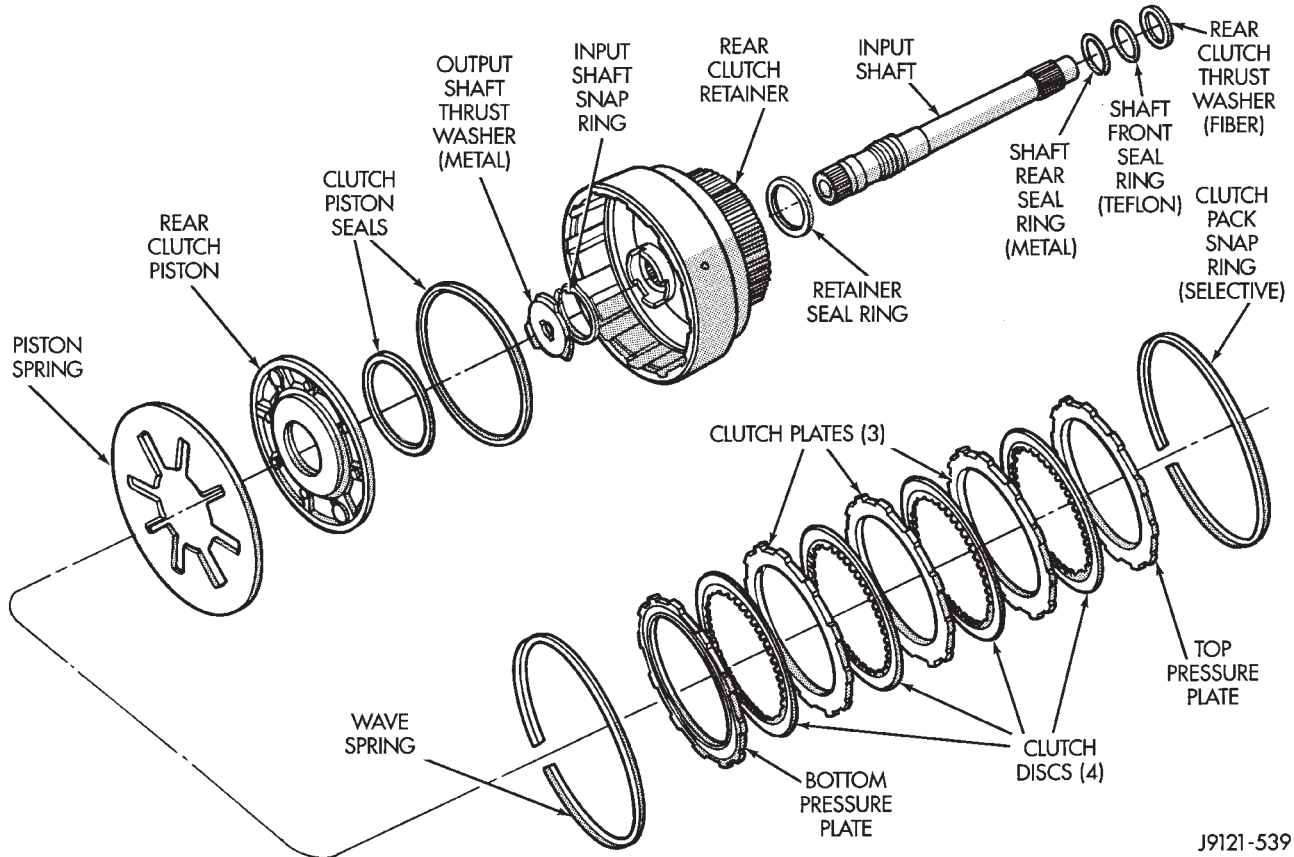
- (c) Zero the dial indicator.
- (d) Lift the pressure plate until it contacts the snap-ring and record the dial indicator reading.

Clearance should be 0.64 - 1.14 mm (0.025 - 0.045 in.). If clearance is incorrect, steel plates, discs, selective snap ring and pressure plates may have to be changed.

The selective snap ring thicknesses are:

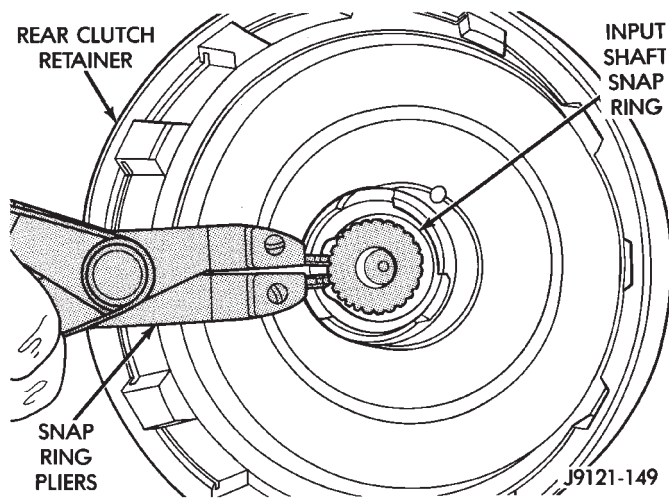
- .107-.109 in.
- .098-.100 in.
- .095-.097 in.
- .083-.085 in.

DISASSEMBLY AND ASSEMBLY (Continued)



J9121-539

Fig. 157 Rear Clutch Components



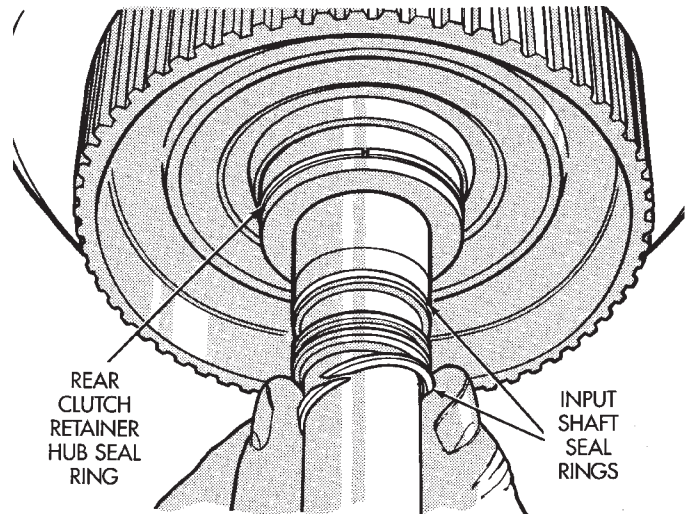
J9121-149

Fig. 158 Removing/Installing Input Shaft Snap-Ring

- .076-.078 in.
- .071-.073 in.
- .060-.062 in.

(16) Coat rear clutch thrust washer with petroleum jelly and install washer over input shaft and into clutch retainer (Fig. 164). Use enough petroleum jelly to hold washer in place.

(17) Set rear clutch aside for installation during final assembly.



J9121-538

Fig. 159 Rear Clutch Retainer And Input Shaft Seal Ring Installation

PLANETARY GEARTRAIN/OUTPUT SHAFT

DISASSEMBLY

- (1) Remove planetary snap ring (Fig. 165).

DISASSEMBLY AND ASSEMBLY (Continued)

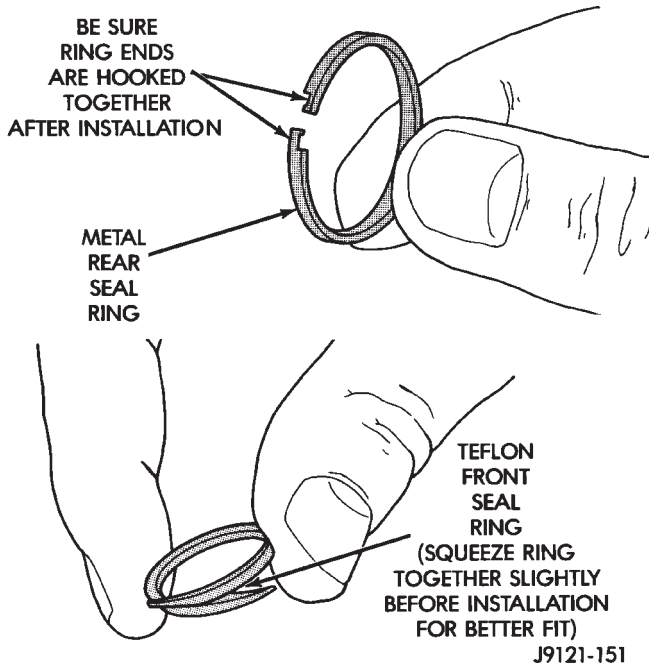


Fig. 160 Input Shaft Seal Ring Identification

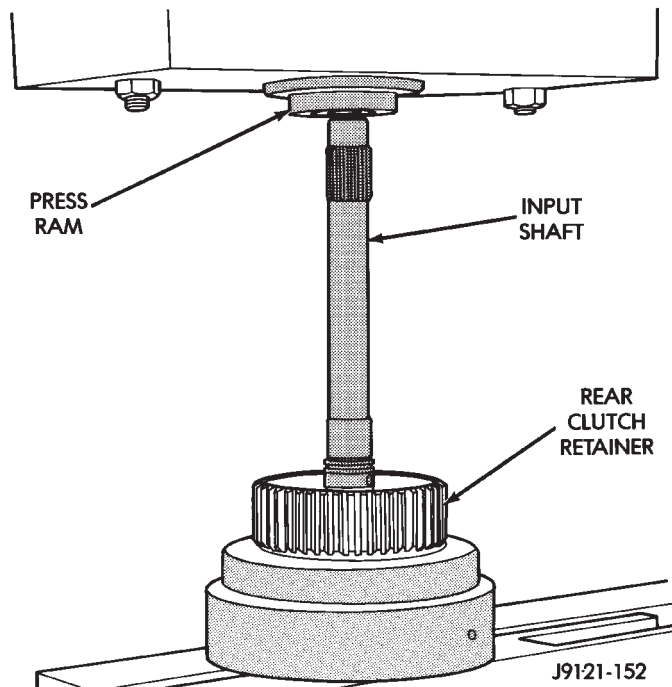


Fig. 161 Pressing Input Shaft Into Rear Clutch Retainer

- (2) Remove front annulus and planetary assembly from driving shell (Fig. 165).
- (3) Remove snap ring that retains front planetary gear in annulus gear (Fig. 166).
- (4) Remove tabbed thrust washer and tabbed thrust plate from hub of front annulus (Fig. 167).
- (5) Separate front annulus and planetary gears (Fig. 167).

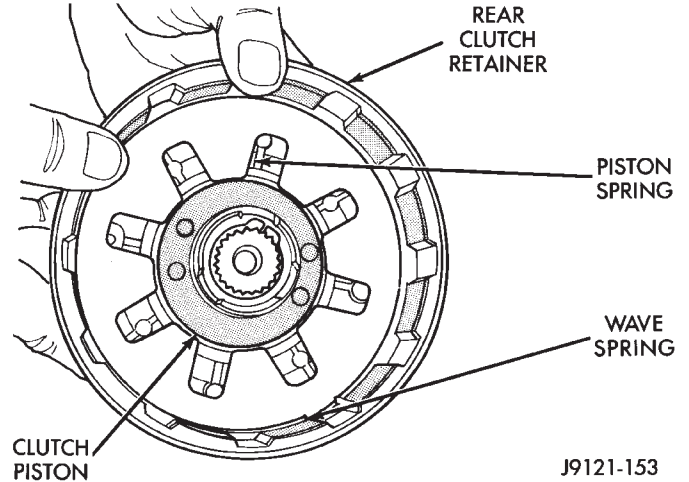


Fig. 162 Piston Spring/Wave Spring Position

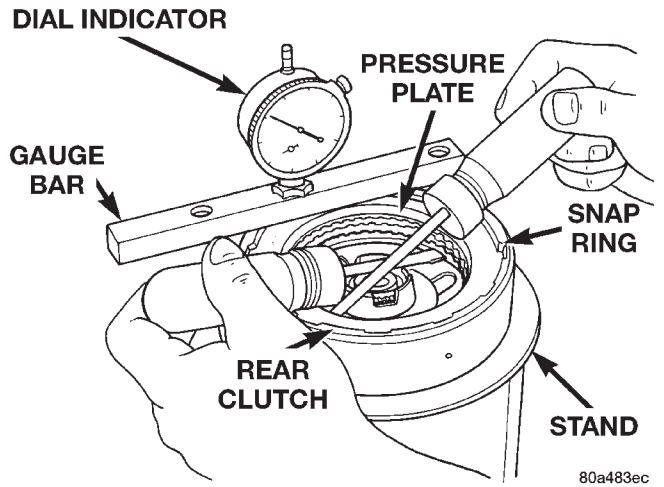


Fig. 163 Checking Rear Clutch Pack Clearance

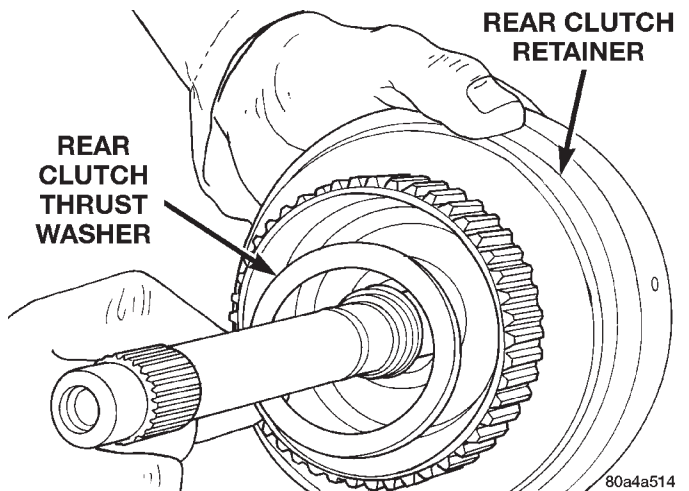
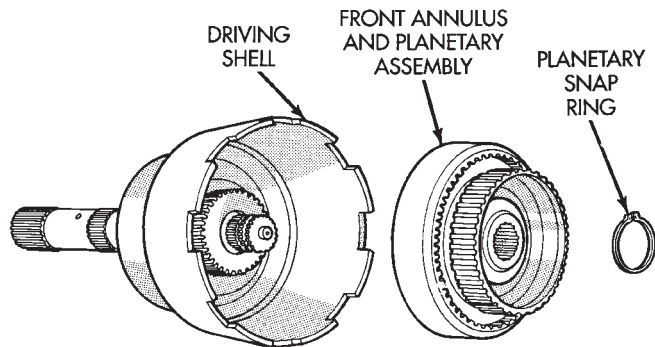


Fig. 164 Installing Rear Clutch Thrust Washer

- (6) Remove front planetary gear front thrust washer from annulus gear hub.
- (7) Separate and remove driving shell, rear planetary and rear annulus from output shaft (Fig. 168).

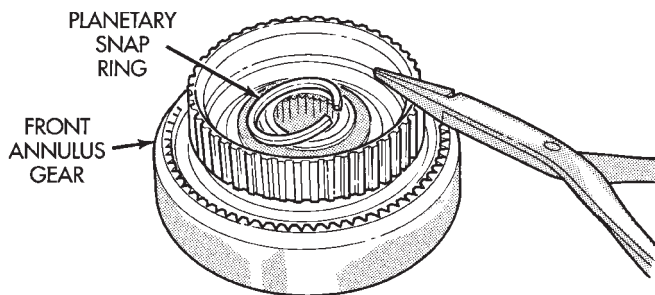
DISASSEMBLY AND ASSEMBLY (Continued)

- (8) Remove front planetary rear thrust washer from driving shell.
- (9) Remove tabbed thrust washers from rear planetary gear.
- (10) Remove lock ring that retains sun gear in driving shell. Then remove sun gear, spacer and thrust plates.



J9421-175

Fig. 165 Front Annulus And Planetary Assembly Removal

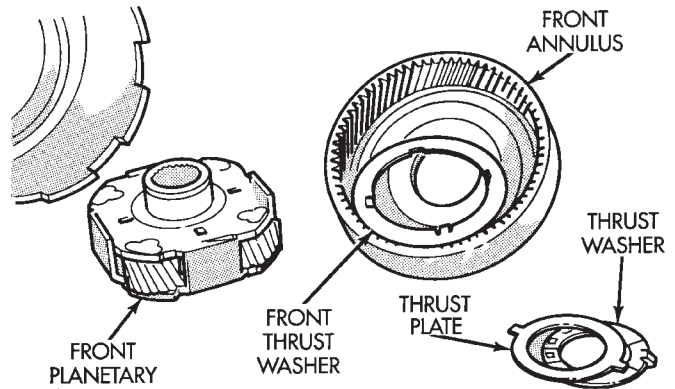


J9421-176

Fig. 166 Front Planetary Snap Ring Removal

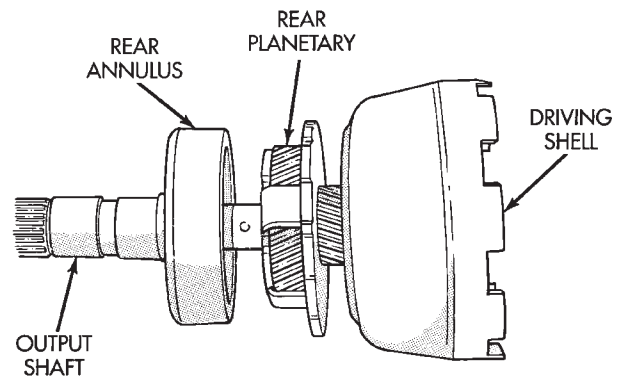
ASSEMBLY

- (1) Lubricate output shaft and planetary components with transmission fluid. Use petroleum jelly to lubricate and hold thrust washers and plates in position.
- (2) Assemble rear annulus gear and support if disassembled. Be sure support snap ring is seated and that shoulder-side of support faces rearward (Fig. 169).
- (3) Install rear thrust washer on rear planetary gear. Use enough petroleum jelly to hold washer in place. Also be sure all four washer tabs are properly engaged in gear slots.
- (4) Install rear annulus over and onto rear planetary gear (Fig. 169).
- (5) Install assembled rear planetary and annulus gear on output shaft (Fig. 170). Verify that assembly is fully seated on shaft.



J9421-177

Fig. 167 Front Planetary And Annulus Gear Disassembly



J9421-178

Fig. 168 Removing Driving Shell, Rear Planetary And Rear Annulus

- (6) Install front thrust washer on rear planetary gear (Fig. 171). Use enough petroleum jelly to hold washer on gear. Be sure all four washer tabs are seated in slots.
- (7) Install spacer on sun gear (Fig. 172).
- (8) Install thrust plate on sun gear (Fig. 173). Note that driving shell thrust plates are interchangeable. Use either plate on sun gear and at front/rear of shell.
- (9) Hold sun gear in place and install thrust plate over sun gear at rear of driving shell (Fig. 174).
- (10) Position wood block on bench and support sun gear on block (Fig. 175). This makes it easier to align and install sun gear lock ring. Keep wood block handy as it will also be used for geartrain end play check.
- (11) Align rear thrust plate on driving shell and install sun gear lock ring. Be sure ring is fully seated in sun gear ring groove (Fig. 176).

DISASSEMBLY AND ASSEMBLY (Continued)

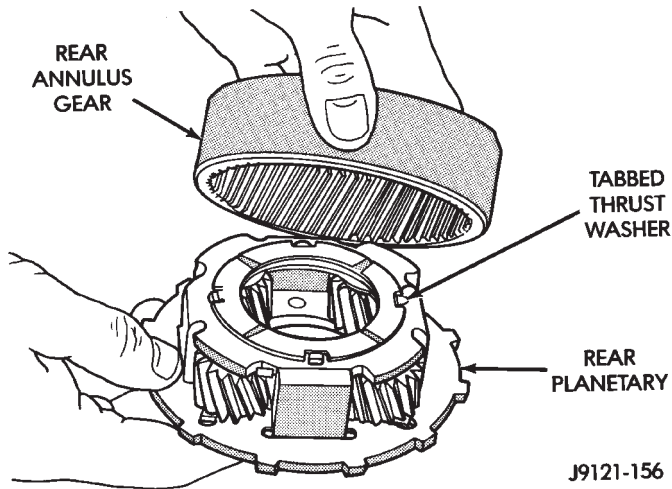


Fig. 169 Assembling Rear Annulus And Planetary Gear

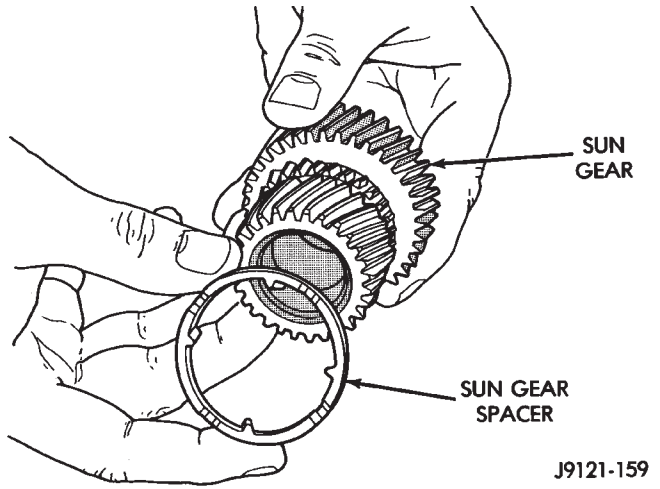


Fig. 172 Installing Spacer On Sun Gear

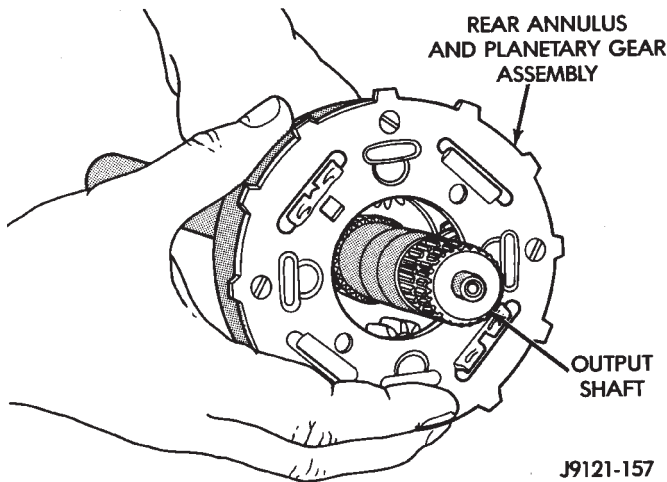


Fig. 170 Installing Rear Annulus And Planetary On Output Shaft

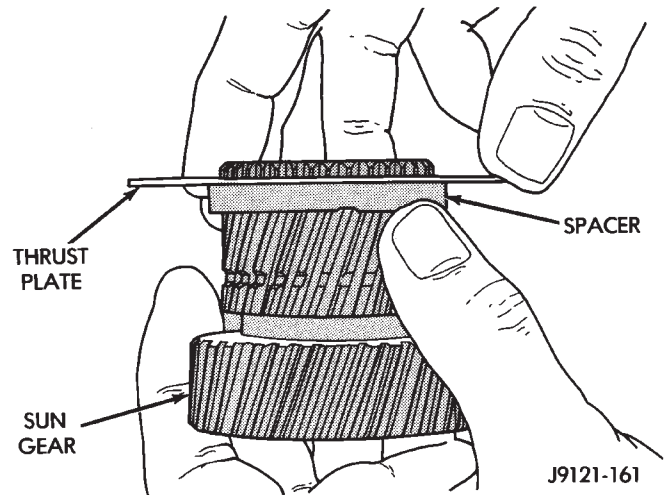


Fig. 173 Installing Driving Shell Front Thrust Plate On Sun Gear

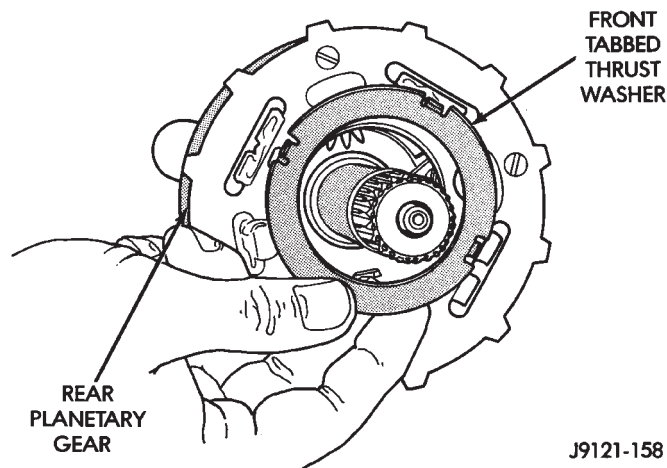


Fig. 171 Installing Rear Planetary Front Thrust Washer

(12) Install assembled driving shell and sun gear on output shaft (Fig. 177).

(13) Install rear thrust washer on front planetary gear (Fig. 178). Use enough petroleum jelly to hold washer in place and be sure all four washer tabs are seated.

(14) Install front planetary gear on output shaft and in driving shell (Fig. 179).

(15) Install front thrust washer on front planetary gear. Use enough petroleum jelly to hold washer in place and be sure all four washer tabs are seated.

(16) Assemble front annulus gear and support, if necessary. Be sure support snap ring is seated.

(17) Install front annulus on front planetary (Fig. 179).

(18) Position thrust plate on front annulus gear support (Fig. 180). **Note that plate has two tabs on it. These tabs fit in notches of annulus hub.**

DISASSEMBLY AND ASSEMBLY (Continued)

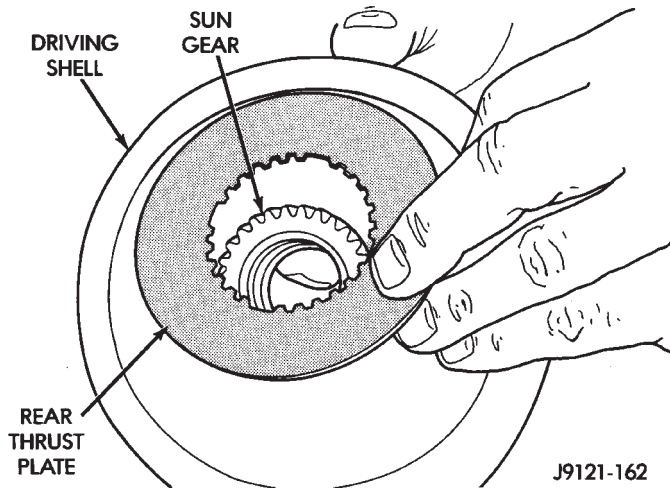


Fig. 174 Installing Driving Shell Rear Thrust Plate

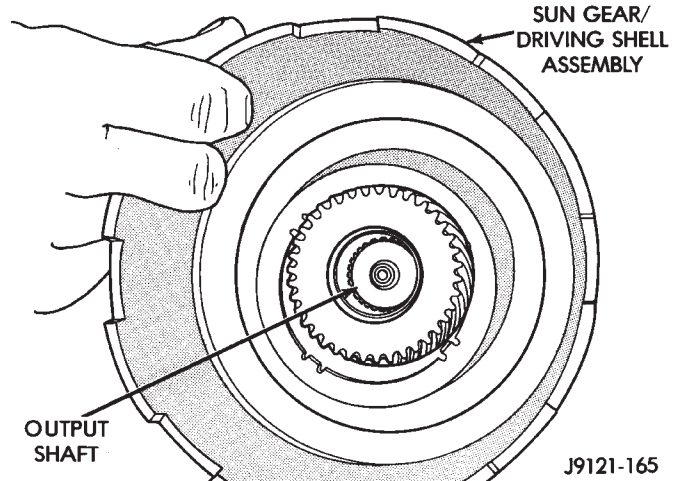


Fig. 177 Installing Assembled Sun Gear And Driving Shell On Output Shaft

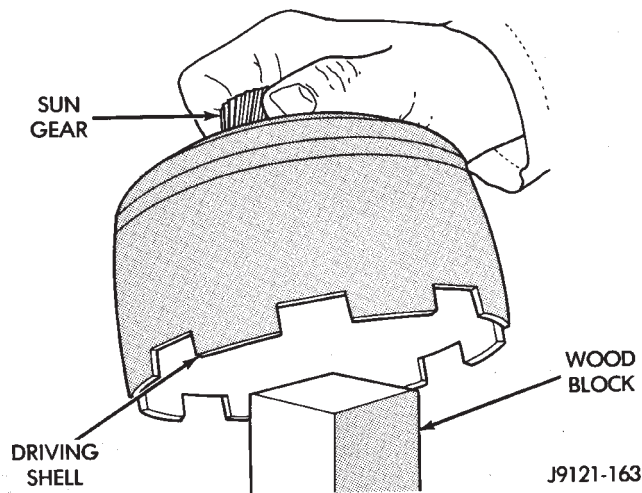


Fig. 175 Supporting Sun Gear On Wood Block

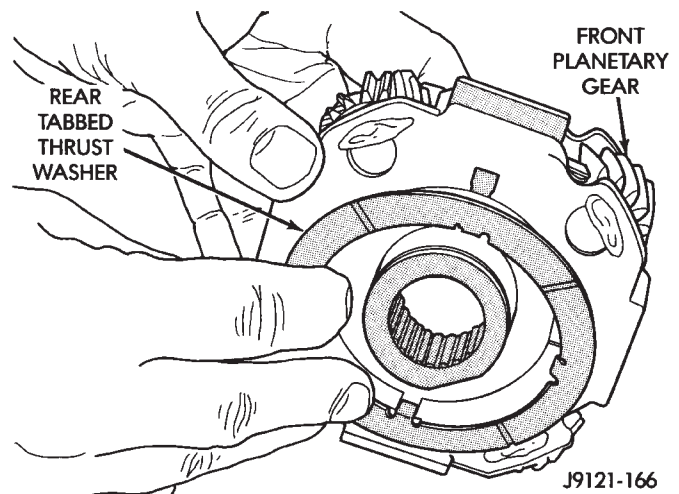


Fig. 178 Installing Rear Thrust Washer On Front Planetary Gear

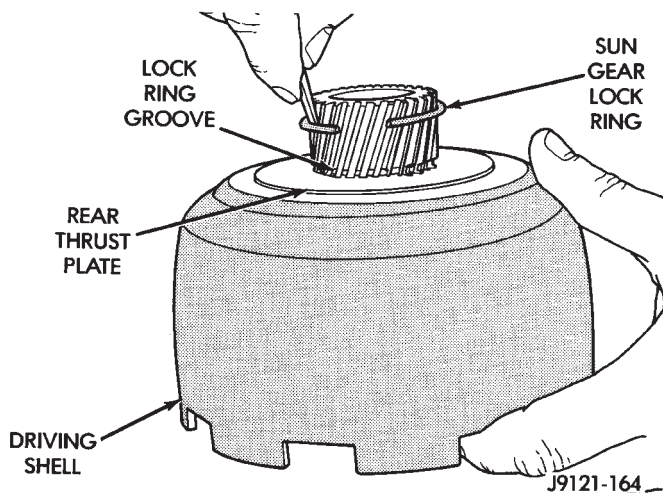


Fig. 176 Installing Sun Gear Lock Ring

(19) Install thrust washer in front annulus (Fig. 181). **Align flat on washer with flat on planetary hub. Also be sure washer tab is facing up.**

(20) Install front annulus snap ring (Fig. 182). Use snap ring pliers to avoid distorting ring during installation. Also be sure ring is fully seated.

(21) Install planetary selective snap ring with snap ring pliers (Fig. 183). Be sure ring is fully seated.

(22) Turn planetary geartrain assembly over so driving shell is facing workbench. Then support geartrain on wood block positioned under forward end of output shaft. This allows geartrain components to move forward for accurate end play check.

(23) Check planetary geartrain end play with feeler gauge (Fig. 184). Gauge goes between shoulder on output shaft and end of rear annulus support.

(24) Geartrain end play should be 0.12 to 1.22 mm (0.005 to 0.048 in.). If end play is incorrect, snap ring (or thrust washers) may have to be replaced. Snap ring is available in three different thicknesses for adjustment purposes.

DISASSEMBLY AND ASSEMBLY (Continued)

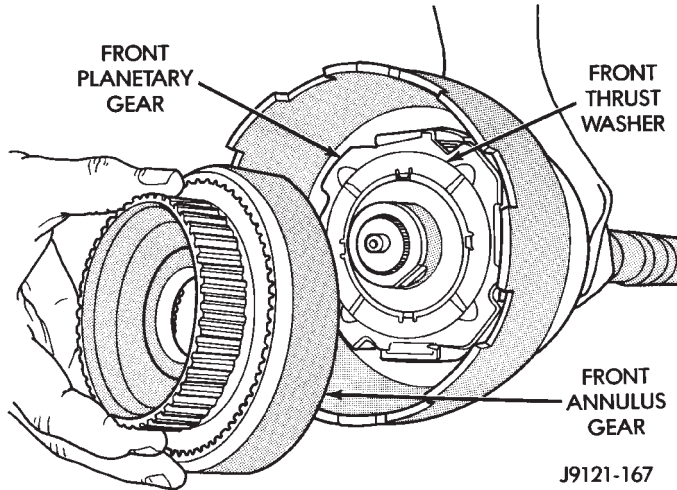


Fig. 179 Installing Front Planetary And Annulus Gears

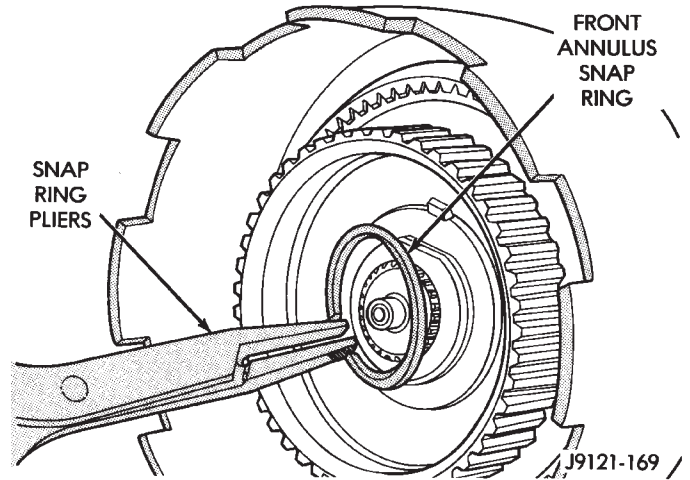


Fig. 182 Installing Front Annulus Snap Ring

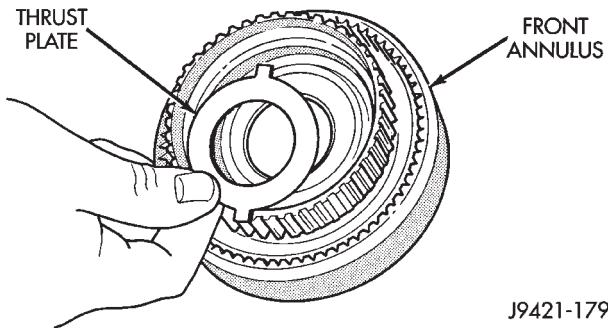


Fig. 180 Positioning Thrust Plate On Front Annulus Support

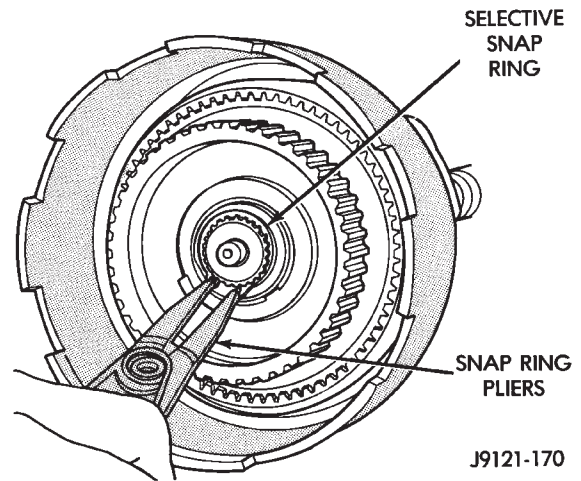


Fig. 183 Installing Planetary Selective Snap Ring

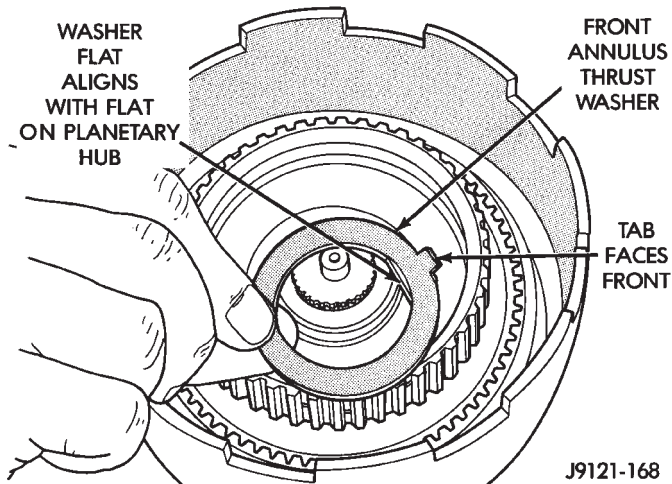


Fig. 181 Installing Front Annulus Thrust Washer

DISASSEMBLY

(1) Remove transmission speed sensor and O-ring seal from overdrive case (Fig. 185).

(2) Remove overdrive piston thrust bearing (Fig. 186).

OVERDRIVE PISTON DISASSEMBLY

(1) Remove overdrive piston thrust plate (Fig. 187). Retain thrust plate. It is a select fit part and may possibly be reused.

(2) Remove intermediate shaft spacer (Fig. 188). Retain spacer. It is a select fit part and may possibly be reused.

(3) Remove overdrive piston from retainer (Fig. 189).

OVERDRIVE CLUTCH PACK DISASSEMBLY

(1) Remove overdrive clutch pack wire retaining ring (Fig. 190).

(2) Remove overdrive clutch pack (Fig. 191).

NOTE: The 42RE transmission has three clutch discs and two clutch plates. The 44RE transmission has four clutch discs and three clutch plates.

DISASSEMBLY AND ASSEMBLY (Continued)

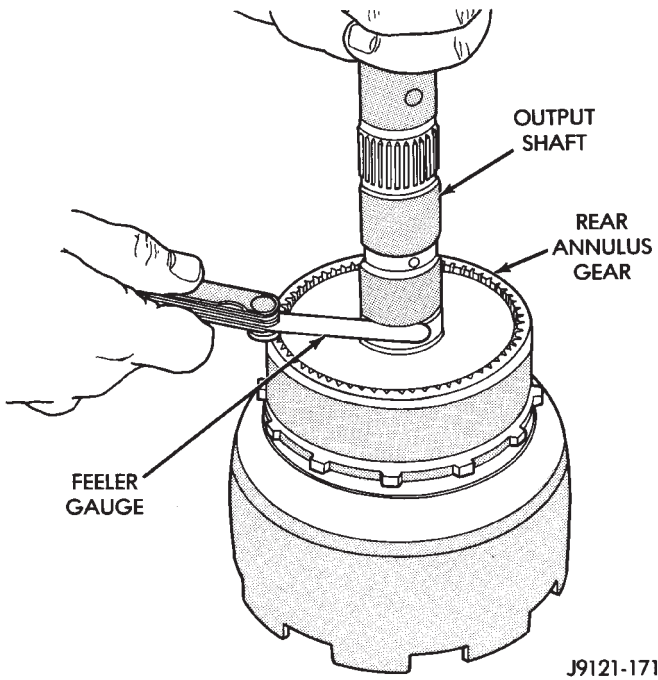


Fig. 184 Checking Planetary Geartrain End Play

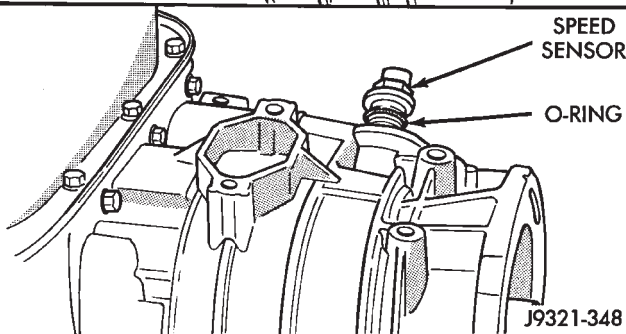
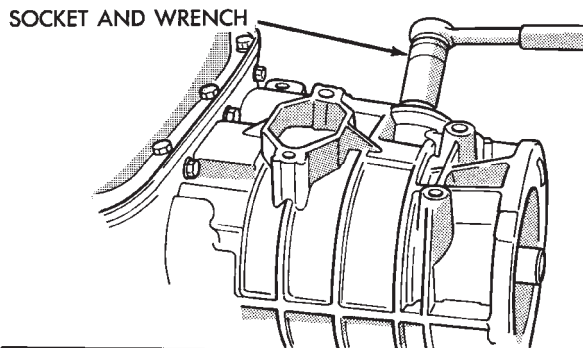


Fig. 185 Transmission Speed Sensor Removal/Installation

(3) Note position of clutch pack components for assembly reference (Fig. 192).

OVERDRIVE GEARTRAIN DISASSEMBLY

(1) Remove overdrive clutch wave spring (Fig. 193).

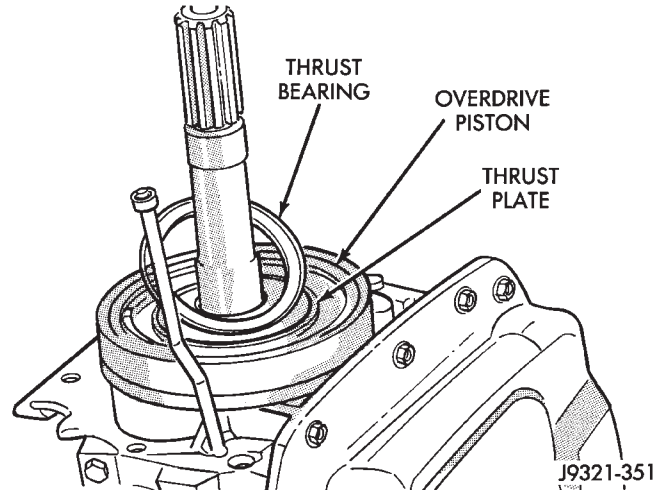


Fig. 186 Overdrive Piston Thrust Bearing Removal/Installation

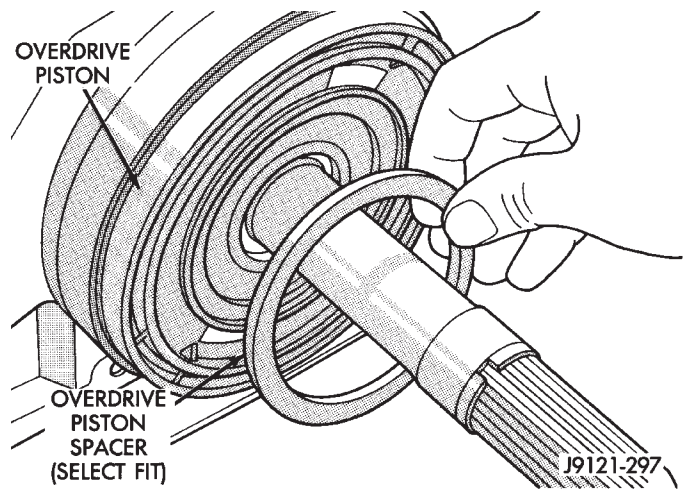


Fig. 187 Overdrive Piston Thrust Plate Removal/Installation

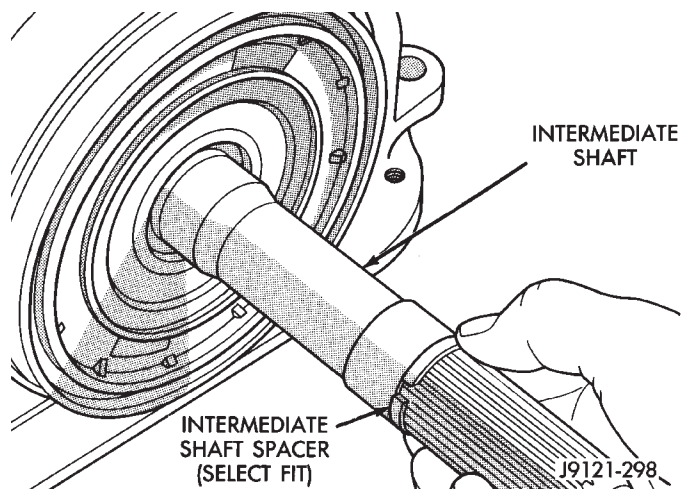


Fig. 188 Intermediate Shaft Spacer Location

DISASSEMBLY AND ASSEMBLY (Continued)

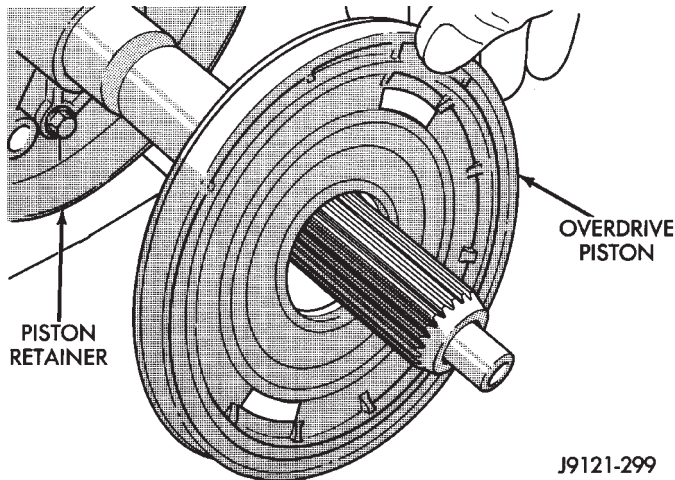


Fig. 189 Overdrive Piston Removal

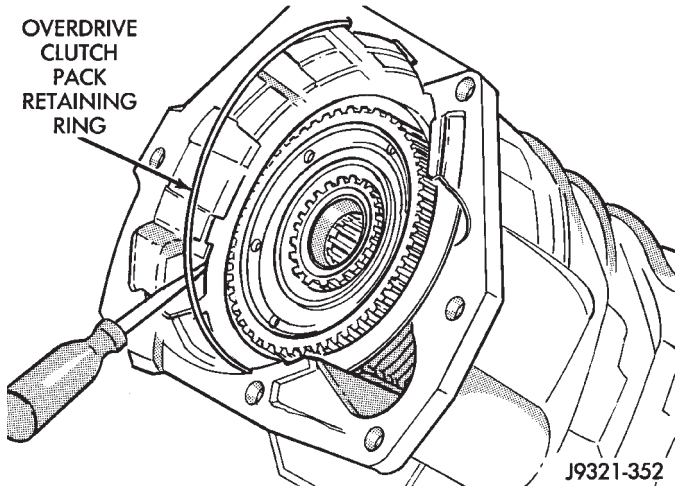


Fig. 190 Removing Overdrive Clutch Pack Retaining Ring

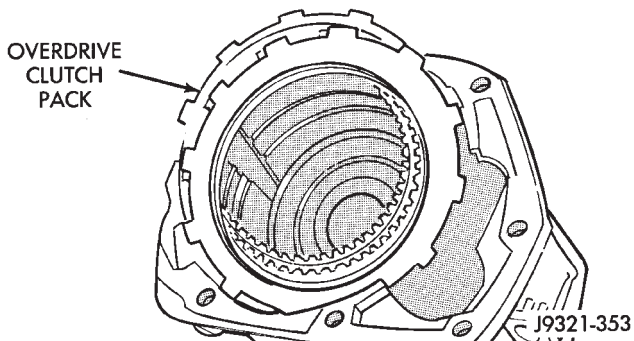


Fig. 191 Overdrive Clutch Pack Removal

(2) Remove overdrive clutch reaction snap ring (Fig. 194). Note that snap ring is located in same groove as wave spring.

(3) Remove Torx head screws that attach access cover and gasket to overdrive case (Fig. 195).

(4) Remove access cover and gasket (Fig. 196).

(5) Expand output shaft bearing snap ring with expanding-type snap ring pliers. Then push output

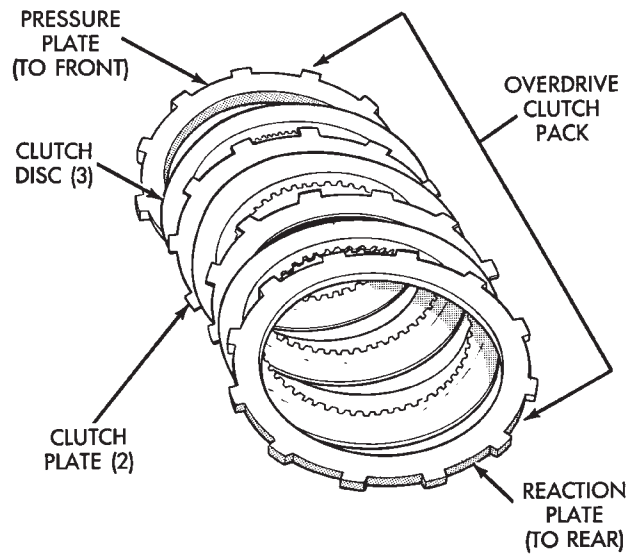


Fig. 192 42RE Overdrive Clutch Component Position

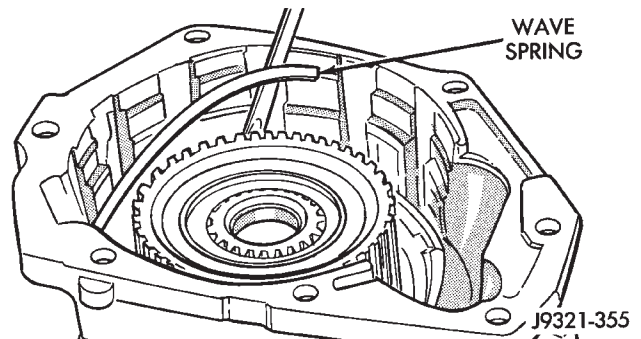


Fig. 193 Overdrive Clutch Wave Spring Removal/Installation

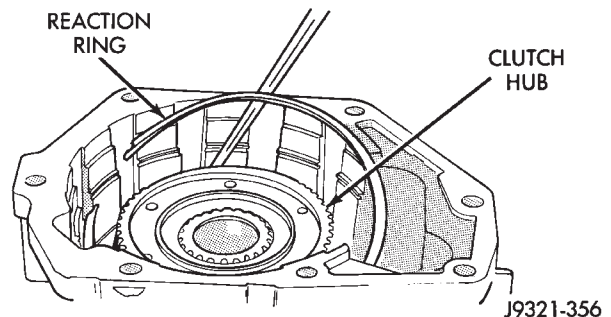


Fig. 194 Overdrive Clutch Reaction Snap Ring Removal/Installation

shaft forward to release shaft bearing from locating ring (Fig. 197).

(6) Lift gear case up and off geartrain assembly (Fig. 198).

DISASSEMBLY AND ASSEMBLY (Continued)

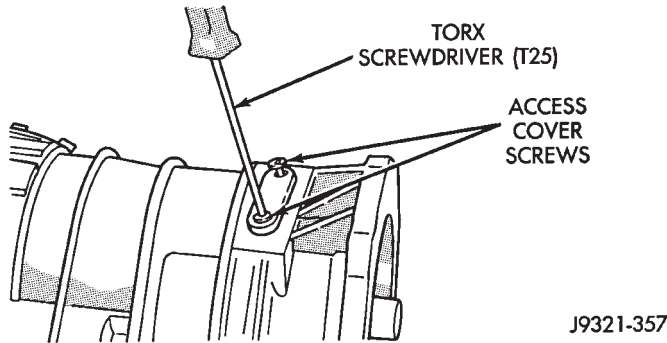


Fig. 195 Access Cover Screw Removal/Installation

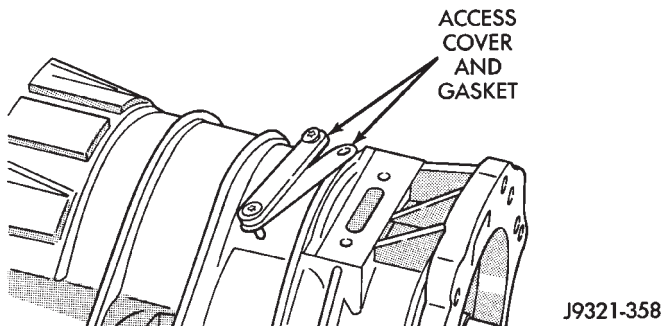


Fig. 196 Access Cover And Gasket Removal/Installation

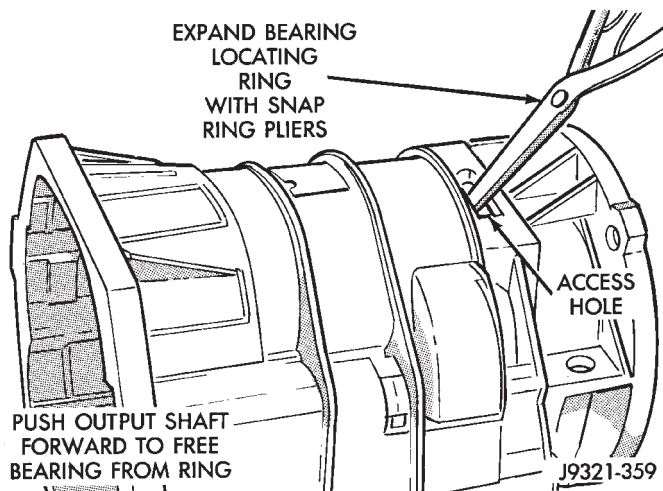


Fig. 197 Releasing Bearing From Locating Ring

- (7) Remove snap ring that retains rear bearing on output shaft.
- (8) Remove rear bearing from output shaft (Fig. 199).

DIRECT CLUTCH, HUB AND SPRING DISASSEMBLY

WARNING: THE NEXT STEP IN DISASSEMBLY INVOLVES COMPRESSING THE DIRECT CLUTCH SPRING. IT IS EXTREMELY IMPORTANT THAT PROPER EQUIPMENT BE USED TO COMPRESS THE SPRING AS SPRING FORCE IS APPROXI-

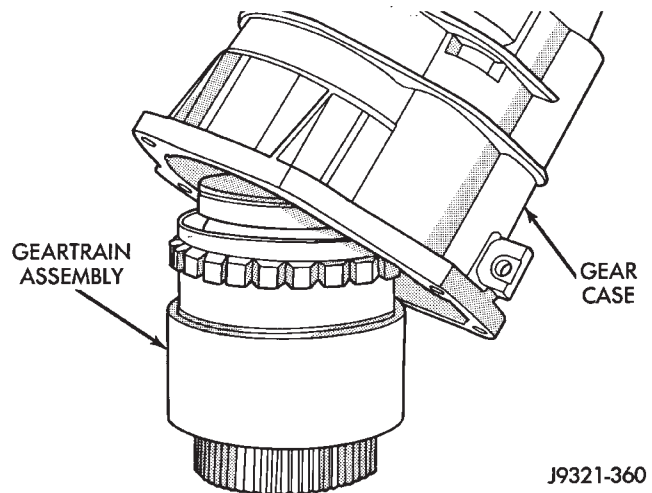


Fig. 198 Removing Gear Case From Geartrain Assembly

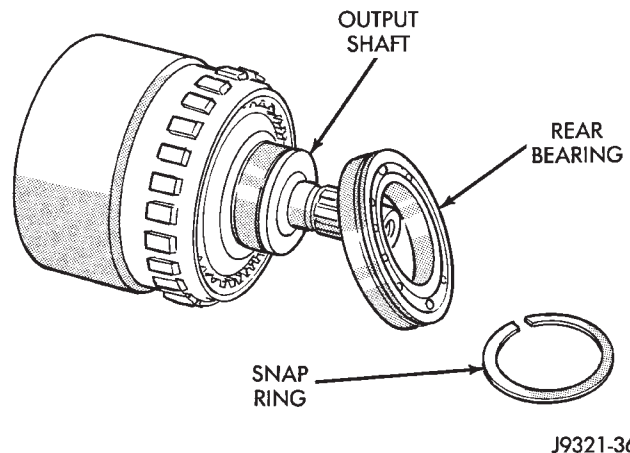


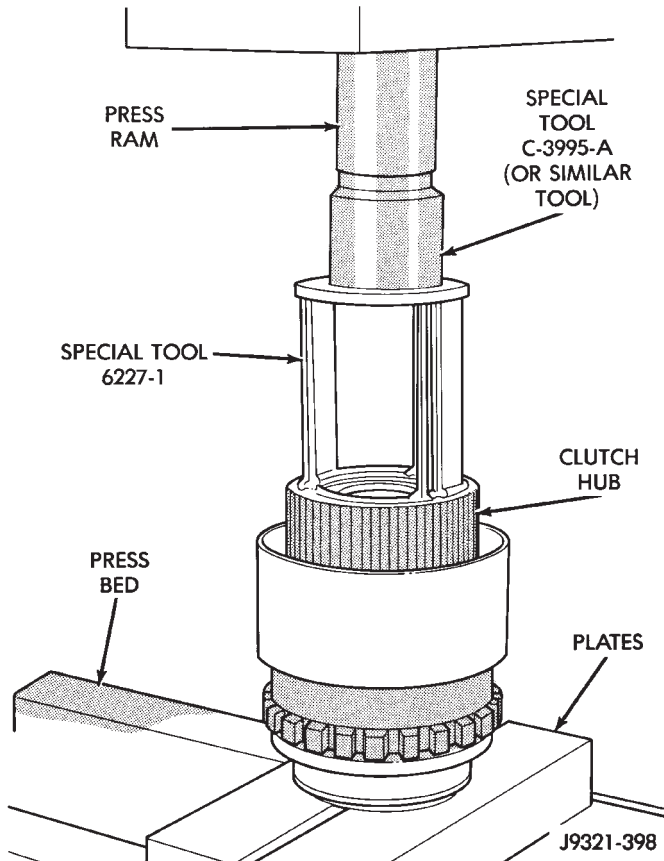
Fig. 199 Rear Bearing Removal

MATELY 830 POUNDS. USE SPRING COMPRESSOR TOOL 6227-1 AND A HYDRAULIC SHOP PRESS WITH A MINIMUM RAM TRAVEL OF 5-6 INCHES. THE PRESS MUST ALSO HAVE A BED THAT CAN BE ADJUSTED UP OR DOWN AS REQUIRED. RELEASE CLUTCH SPRING TENSION SLOWLY AND COMPLETELY TO AVOID PERSONAL INJURY.

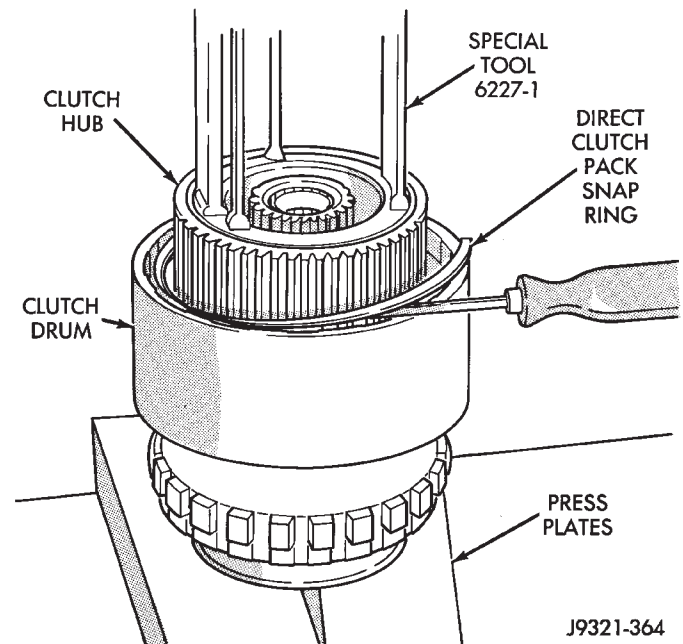
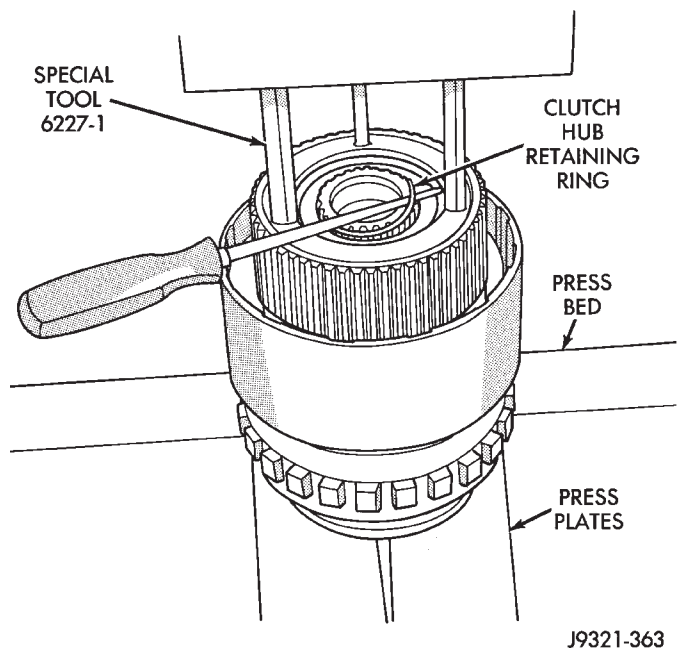
- (1) Mount geartrain assembly in shop press (Fig. 200).
- (2) Position Compressor Tool 6227-1 on clutch hub (Fig. 200). Support output shaft flange with steel press plates as shown and center assembly under press ram.
- (3) Apply press pressure slowly. Compress hub and spring far enough to expose clutch hub retaining ring and relieve spring pressure on clutch pack snap ring (Fig. 200).
- (4) Remove direct clutch pack snap ring (Fig. 201).

DISASSEMBLY AND ASSEMBLY (Continued)

- (5) Remove direct clutch hub retaining ring (Fig. 202).
- (6) Release press load slowly and completely (Fig. 203).
- (7) Remove Special Tool 6227-1. Then remove clutch pack from hub (Fig. 203).

**Fig. 200 Geartrain Mounted In Shop Press****Geartrain Disassembly**

- (1) Remove direct clutch hub and spring (Fig. 204).
- (2) Remove sun gear and spring plate. Then remove planetary thrust bearing and planetary gear (Fig. 205).
- (3) Remove overrunning clutch assembly with expanding type snap ring pliers (Fig. 206). Insert pliers into clutch hub. Expand pliers to grip hub splines and remove clutch with counterclockwise, twisting motion.
- (4) Remove thrust bearing from overrunning clutch hub.
- (5) Remove overrunning clutch from hub.
- (6) Mark position of annulus gear and direct clutch drum for assembly alignment reference (Fig. 207). Use small center punch or scriber to make alignment marks.
- (7) Remove direct clutch drum rear retaining ring (Fig. 208).
- (8) Remove direct clutch drum outer retaining ring (Fig. 209).

**Fig. 201 Direct Clutch Pack Snap Ring Removal****Fig. 202 Direct Clutch Hub Retaining Ring Removal**

- (9) Mark annulus gear and output shaft for assembly alignment reference (Fig. 210). Use punch or scriber to mark gear and shaft.
- (10) Remove snap ring that secures annulus gear on output shaft (Fig. 211). Use two screwdrivers to unseat and work snap ring out of groove as shown.
- (11) Remove annulus gear from output shaft (Fig. 212). Use rawhide or plastic mallet to tap gear off shaft.

DISASSEMBLY AND ASSEMBLY (Continued)

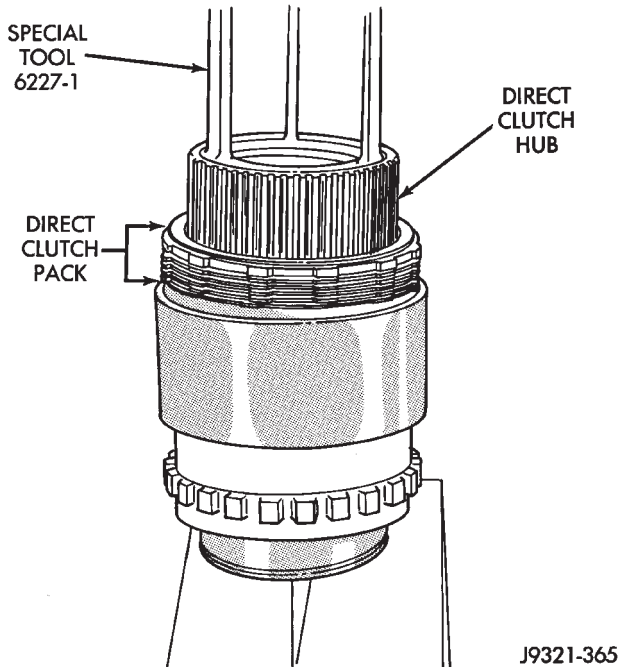


Fig. 203 Direct Clutch Pack Removal

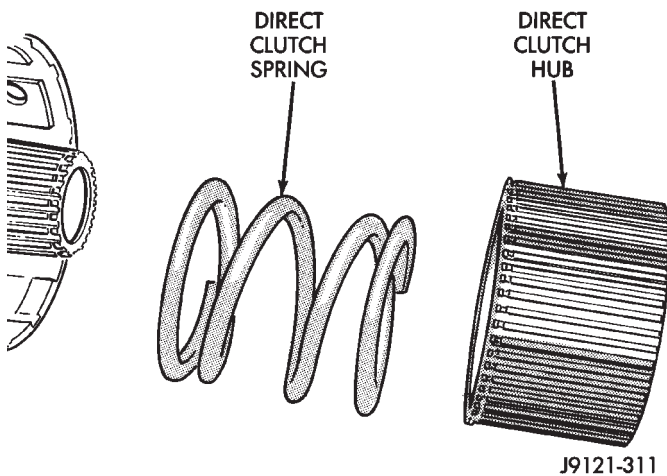


Fig. 204 Direct Clutch Hub And Spring Removal

GEAR CASE AND PARK LOCK DISASSEMBLY

- (1) Remove locating ring from gear case.
- (2) Remove park pawl shaft retaining bolt and remove shaft, pawl and spring.
- (3) Remove reaction plug snap ring and remove reaction plug.
- (4) Remove output shaft seal.

ASSEMBLY

GEARTRAIN AND DIRECT CLUTCH ASSEMBLY

- (1) Soak direct clutch and overdrive clutch discs in Mopar® ATF Plus 3, type 7176, transmission fluid. Allow discs to soak for 10-20 minutes.

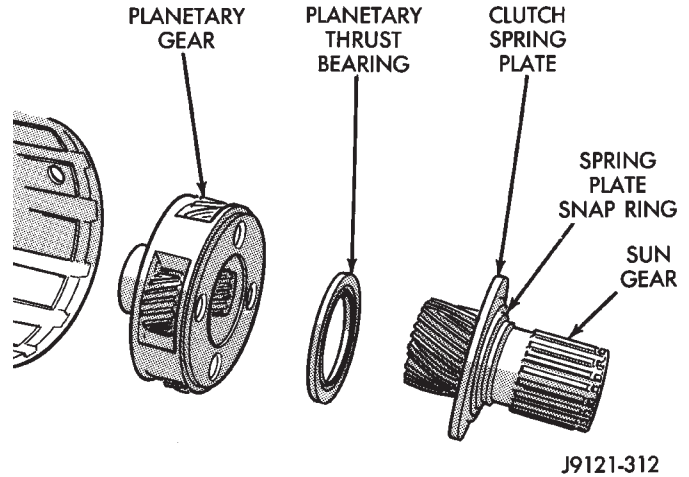


Fig. 205 Removing Sun Gear, Thrust Bearing And Planetary Gear

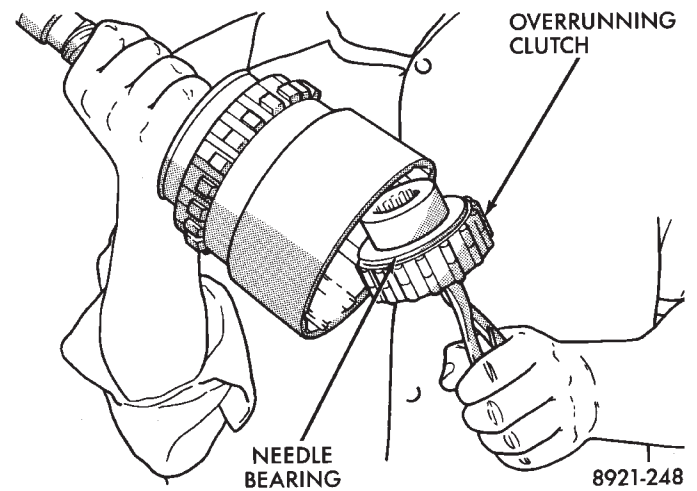


Fig. 206 Overrunning Clutch Assembly Removal/Installation

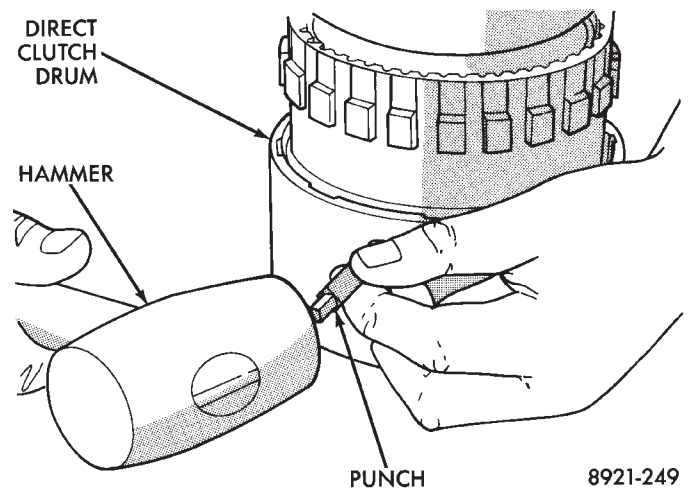
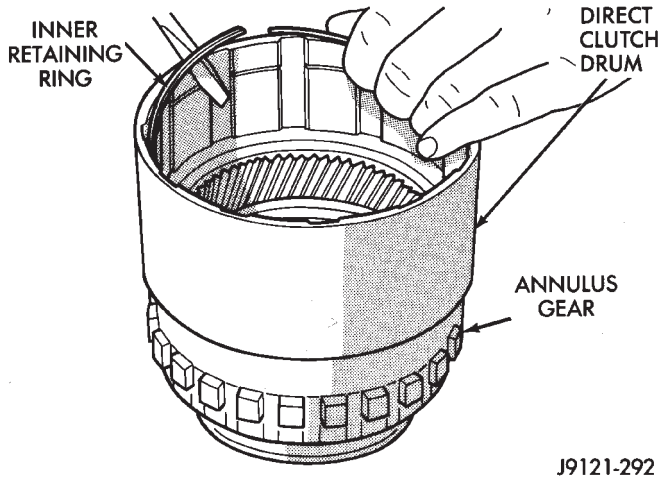
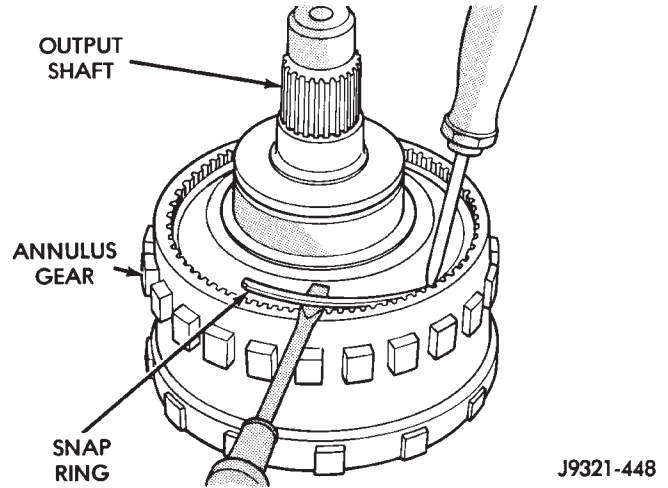


Fig. 207 Marking Direct Clutch Drum And Annulus Gear For Assembly Alignment

DISASSEMBLY AND ASSEMBLY (Continued)



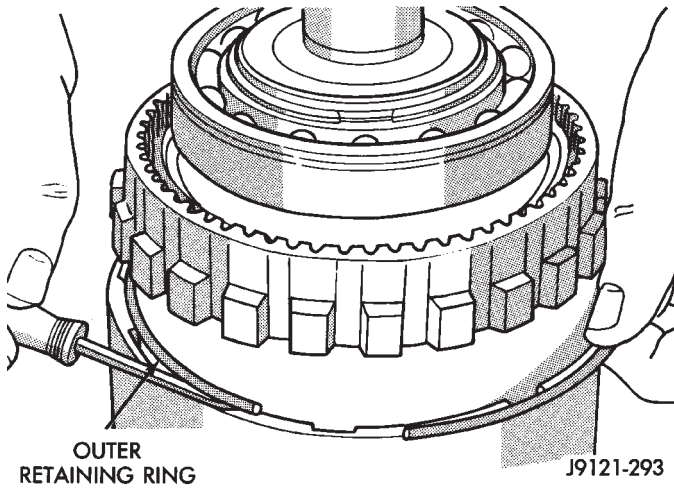
J9121-292



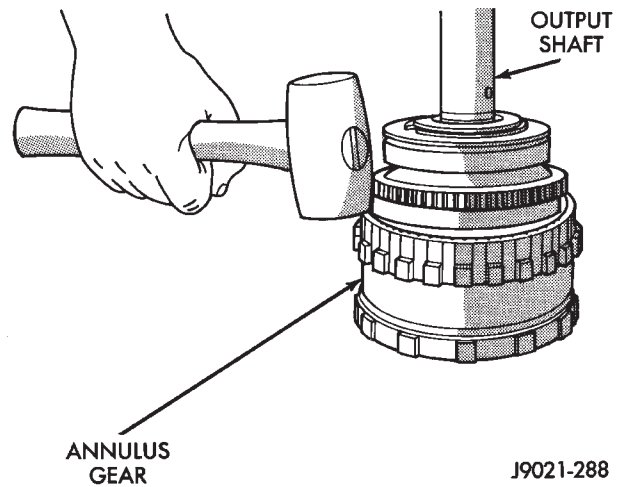
J9321-448

Fig. 208 Clutch Drum Inner Retaining Ring Removal

Fig. 211 Annulus Gear Snap Ring Removal



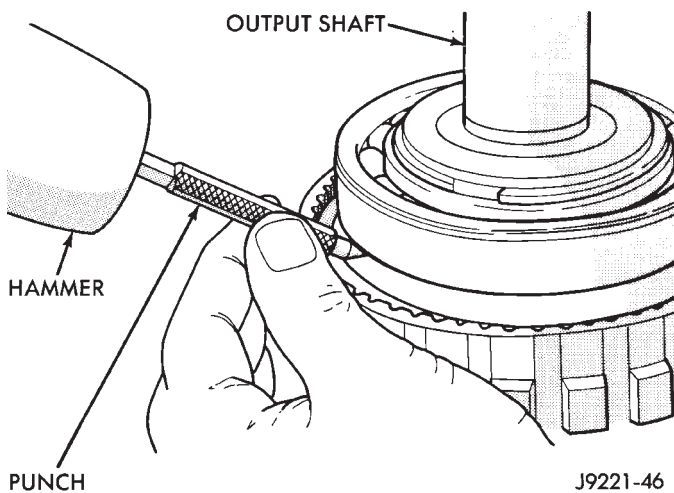
J9121-293



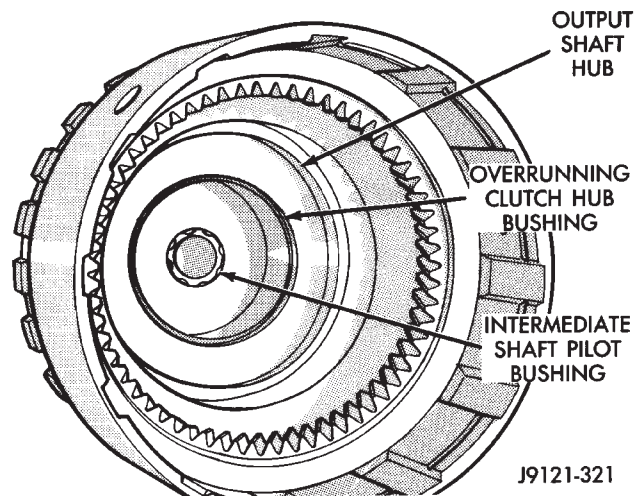
J9021-288

Fig. 209 Clutch Drum Outer Retaining Ring Removal

Fig. 212 Annulus Gear Removal



J9221-46



J9121-321

Fig. 210 Marking Annulus Gear And Output Shaft For Assembly Alignment

Fig. 213 Output Shaft Pilot Bushing

(2) Install new pilot bushing and clutch hub bushing in output shaft if necessary (Fig. 213). Lubricate bushings with petroleum jelly, or transmission fluid.

(3) Install annulus gear on output shaft, if removed. Then install annulus gear retaining snap ring (Fig. 214).

DISASSEMBLY AND ASSEMBLY (Continued)

(4) Align and install clutch drum on annulus gear (Fig. 215). Be sure drum is engaged in annulus gear lugs.

(5) Install clutch drum outer retaining ring (Fig. 215).

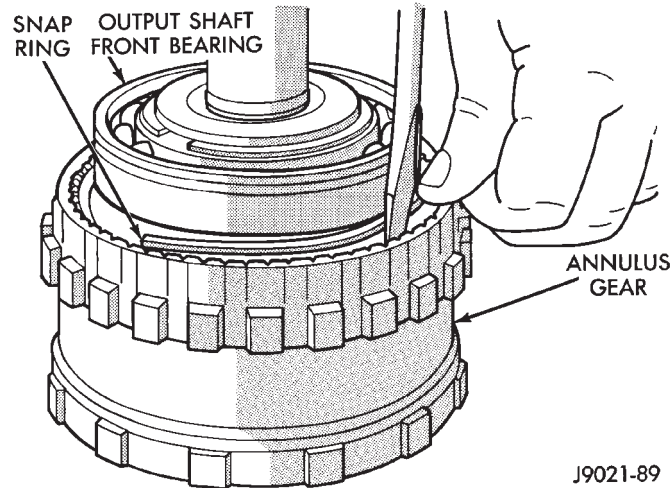


Fig. 214 Annulus Gear Installation

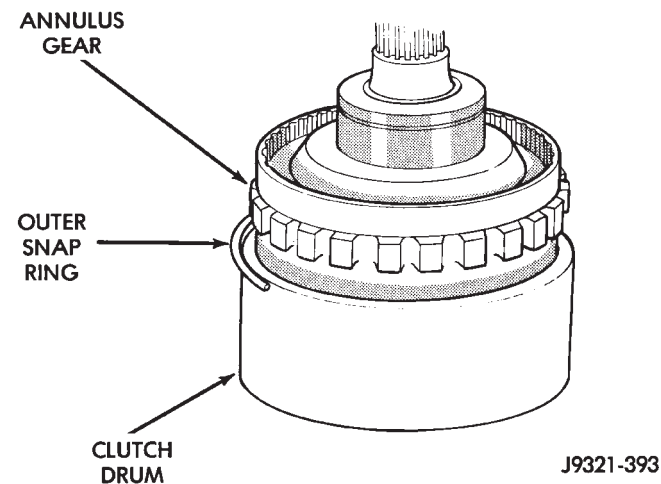


Fig. 215 Clutch Drum And Outer Retaining Ring Installation

(6) Slide clutch drum forward and install inner retaining ring (Fig. 216).

(7) Install rear bearing and snap ring on output shaft (Fig. 217). Be sure locating ring groove in bearing is toward rear.

(8) Install overrunning clutch on hub (Fig. 218). **Note that clutch only fits one way. Shoulder on clutch should seat in small recess at edge of hub.**

(9) Install thrust bearing on overrunning clutch hub. Use generous amount of petroleum jelly to hold bearing in place for installation. **Bearing fits one way only. Be sure bearing is seated squarely against hub. Reinstall bearing if it does not seat squarely.**

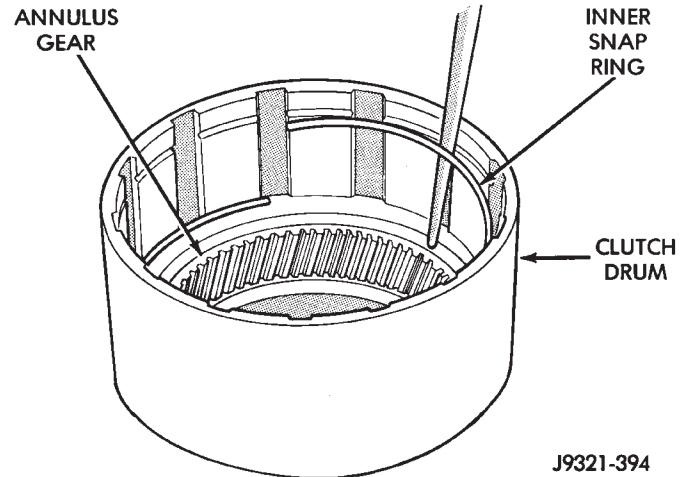


Fig. 216 Clutch Drum Inner Retaining Ring Installation

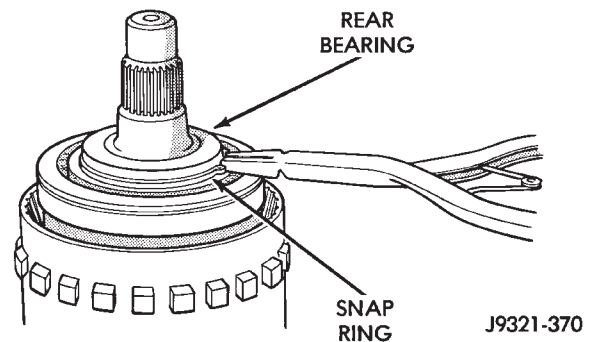


Fig. 217 Rear Bearing And Snap Ring Installation

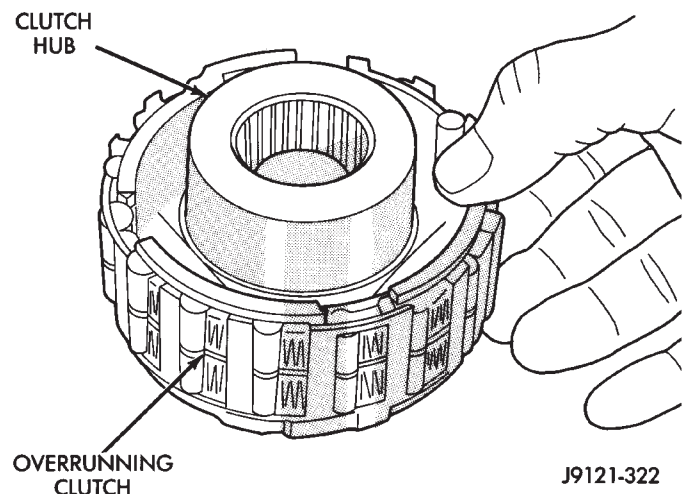


Fig. 218 Assembling Overrunning Clutch And Hub

(10) Install overrunning clutch in output shaft (Fig. 219). Insert snap ring pliers in hub splines. Expand pliers to grip hub. Then install assembly with counterclockwise, twisting motion.

DISASSEMBLY AND ASSEMBLY (Continued)

(11) Install planetary gear in annulus gear (Fig. 220). **Be sure planetary pinions are fully seated in annulus gear before proceeding.**

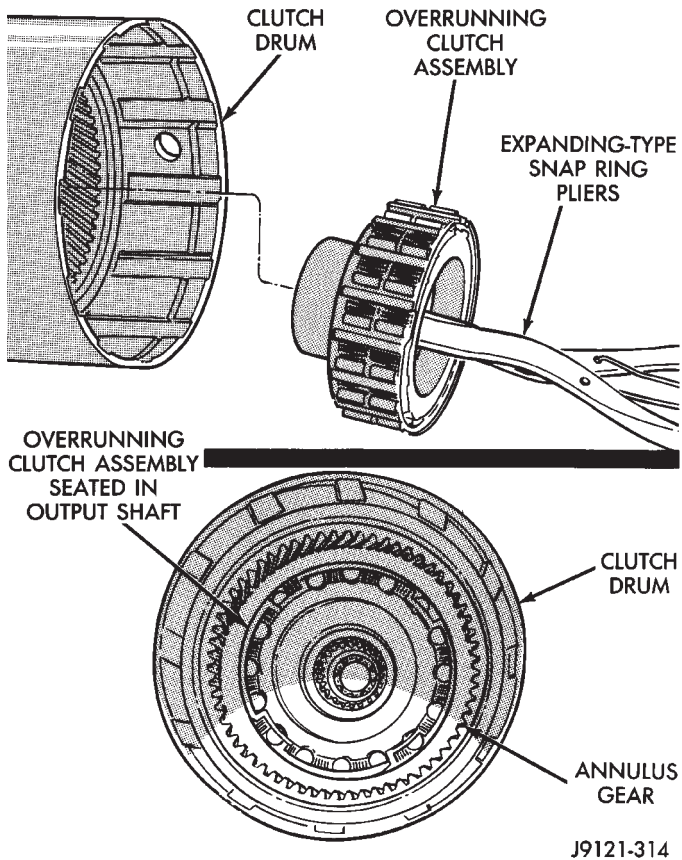


Fig. 219 Overrunning Clutch Installation

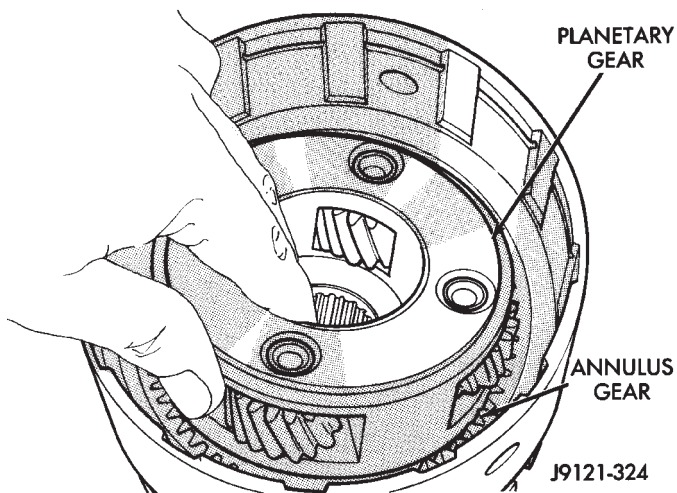


Fig. 220 Planetary Gear Installation

(12) Coat planetary thrust bearing and bearing contact surface of spring plate with generous amount of petroleum jelly. This will help hold bearing in place during installation.

(13) Install planetary thrust bearing on sun gear (Fig. 221). Slide bearing onto gear and seat it against

spring plate as shown. **Bearing fits one way only. If it does not seat squarely against spring plate, remove and reposition bearing.**

(14) Install assembled sun gear, spring plate and thrust bearing (Fig. 222). Be sure sun gear and thrust bearing are fully seated before proceeding.

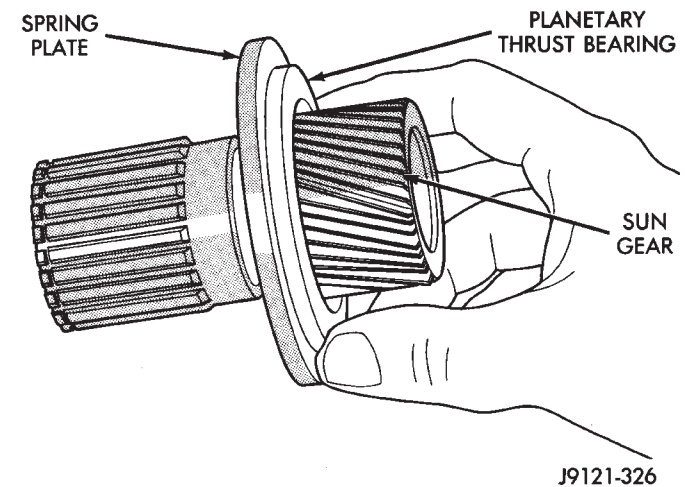


Fig. 221 Planetary Thrust Bearing Installation

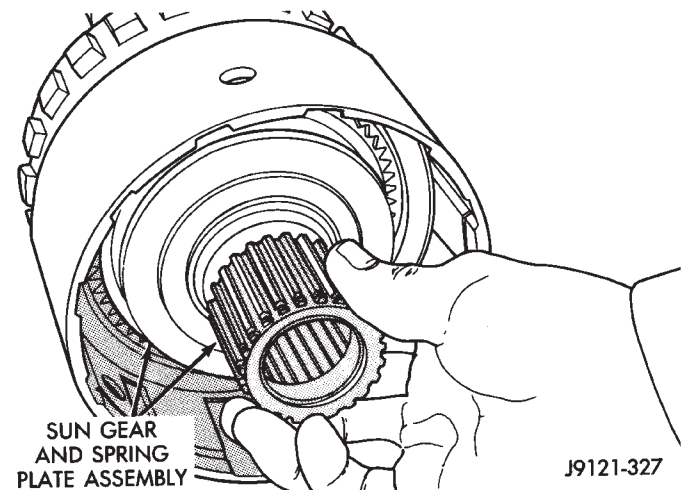


Fig. 222 Sun Gear Installation

(15) Mount assembled output shaft, annulus gear, and clutch drum in shop press. Direct clutch spring, hub and clutch pack are easier to install with assembly mounted in press.

(16) Align splines in hubs of planetary gear and overrunning clutch with Alignment tool 6227-2 (Fig. 223). Insert tool through sun gear and into splines of both hubs. Be sure alignment tool is fully seated before proceeding.

(17) Install direct clutch spring (Fig. 224). Be sure spring is properly seated on spring plate.

NOTE: The 42RE transmission has 6 direct clutch discs and 5 clutch plates. The 44RE transmission has 8 direct clutch discs and 7 clutch plates.

DISASSEMBLY AND ASSEMBLY (Continued)

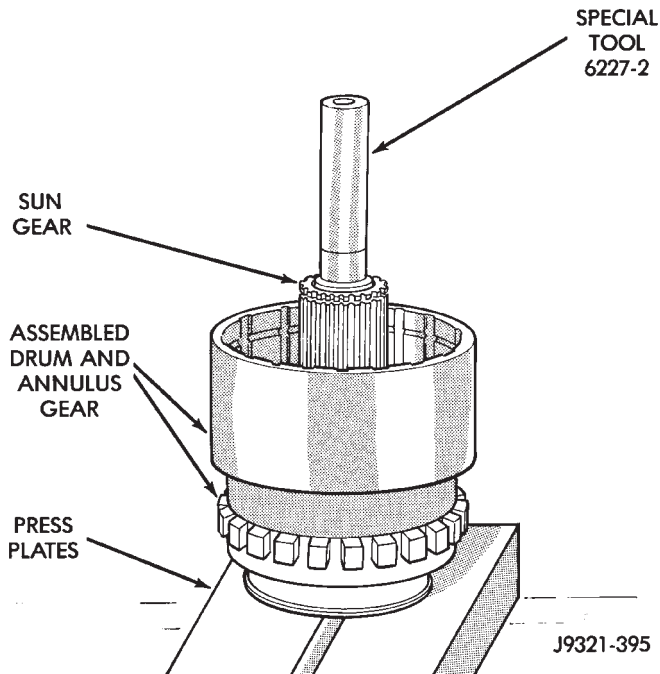


Fig. 223 Alignment Tool Installation

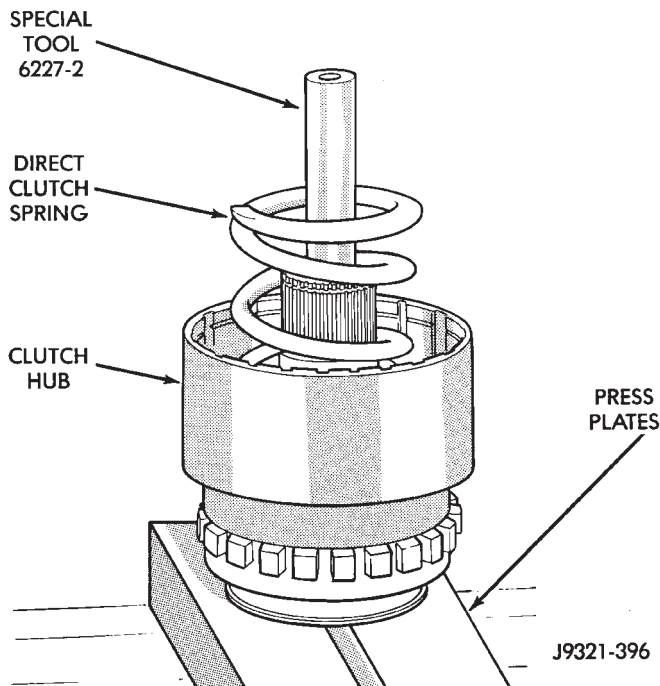


Fig. 224 Direct Clutch Spring Installation

(18) Assemble and install direct clutch pack on hub as follows:

(a) Assemble clutch pack components (Fig. 225) or (Fig. 226).

(b) Install direct clutch reaction plate on clutch hub first. **Note that one side of reaction plate is counterbored. Be sure this side faces rearward. Splines at rear of hub are raised slightly. Counterbore in plate fits over raised**

splines. Plate should be flush with this end of hub (Fig. 227).

(c) Install first clutch disc followed by a steel plate until all discs and plates have been installed.

(d) Install pressure plate. This is last clutch pack item to be installed. **Be sure plate is installed with shoulder side facing upward (Fig. 228).**

(19) Install clutch hub and clutch pack on direct clutch spring (Fig. 229). **Be sure hub is started on sun gear splines before proceeding.**

WARNING: THE NEXT STEP IN GEARTRAIN ASSEMBLY INVOLVES COMPRESSING THE DIRECT CLUTCH HUB AND SPRING. IT IS EXTREMELY IMPORTANT THAT PROPER EQUIPMENT BE USED TO COMPRESS THE SPRING AS SPRING FORCE IS APPROXIMATELY 830 POUNDS. USE COMPRESSOR TOOL C-6227-1 AND A HYDRAULIC-TYPE SHOP PRESS WITH A MINIMUM RAM TRAVEL OF 6 INCHES. THE PRESS MUST ALSO HAVE A BED THAT CAN BE ADJUSTED UP OR DOWN AS REQUIRED. RELEASE CLUTCH SPRING TENSION SLOWLY AND COMPLETELY TO AVOID PERSONAL INJURY.

(20) Position Compressor Tool 6227-1 on clutch hub.

(21) Compress clutch hub and spring just enough to place tension on hub and hold it in place.

(22) Slowly compress clutch hub and spring. Compress spring and hub only enough to expose ring grooves for clutch pack snap ring and clutch hub retaining ring.

(23) Realign clutch pack on hub and seat clutch discs and plates in clutch drum.

(24) Install direct clutch pack snap ring (Fig. 230). **Be very sure snap ring is fully seated in clutch drum ring groove.**

(25) Install clutch hub retaining ring (Fig. 231). **Be very sure retaining ring is fully seated in sun gear ring groove.**

(26) Slowly release press ram, remove compressor tools and remove geartrain assembly.

GEAR CASE ASSEMBLY

(1) Position park pawl and spring in case and install park pawl shaft. Verify that end of spring with 90° bend is hooked to pawl and straight end of spring is seated against case.

(2) Install pawl shaft retaining bolt. Tighten bolt to 27 N·m (20 ft. lbs.) torque.

(3) Install park lock reaction plug. **Note that plug has locating pin at rear (Fig. 232). Be sure pin is seated in hole in case before installing snap ring.**

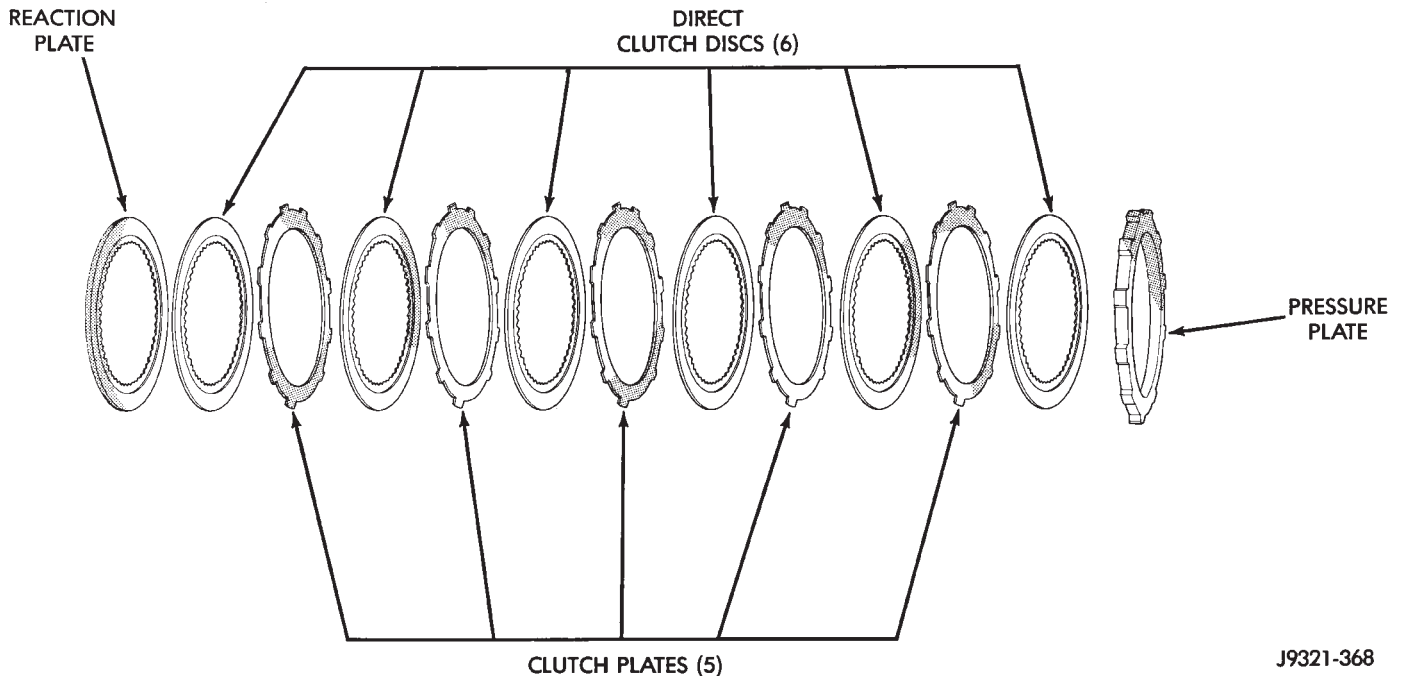
DISASSEMBLY AND ASSEMBLY (Continued)

Fig. 225 42RE Direct Clutch Pack Components

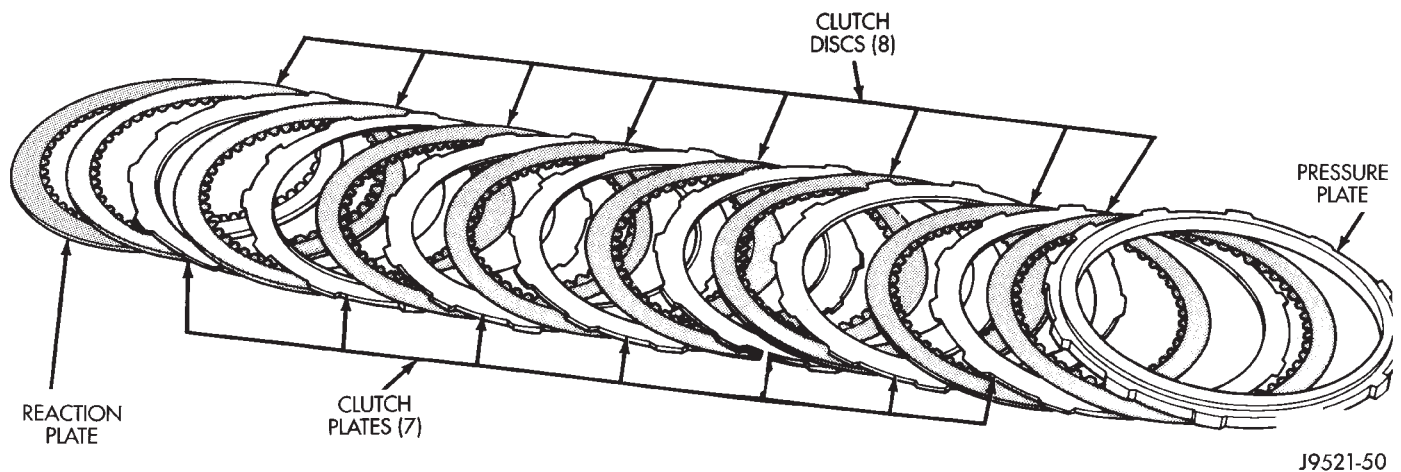


Fig. 226 44RE Direct Clutch Pack Components

(4) Install reaction plug snap-ring (Fig. 233). **Compress snap ring only enough for installation; do not distort it.**

(5) Install new seal in gear case. On 4x4 gear case, use Tool Handle C-4171 and Installer C-3860-A to seat seal in case. On 4 x 2 gear case, use same Handle C-4171 and Installer C-3995-A to seat seal in case.

(6) Verify that tab ends of rear bearing locating ring extend into access hole in gear case (Fig. 234).

(7) Support geartrain on Tool 6227-1 (Fig. 235). Be sure tool is securely seated in clutch hub.

(8) Install overdrive gear case on geartrain (Fig. 235).

(9) Expand front bearing locating ring with snap ring pliers (Fig. 236). Then slide case downward until locating ring locks in bearing groove and release snap ring.

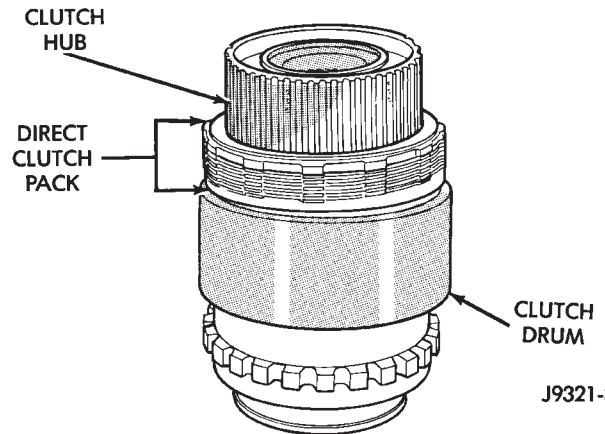
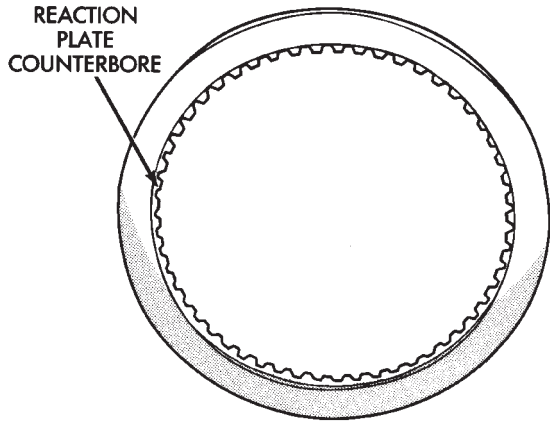
(10) Install locating ring access cover and gasket in overdrive unit case (Fig. 237).

OVERDRIVE CLUTCH ASSEMBLY

(1) Install overdrive clutch reaction ring first. Reaction ring is flat with notched ends (Fig. 238).

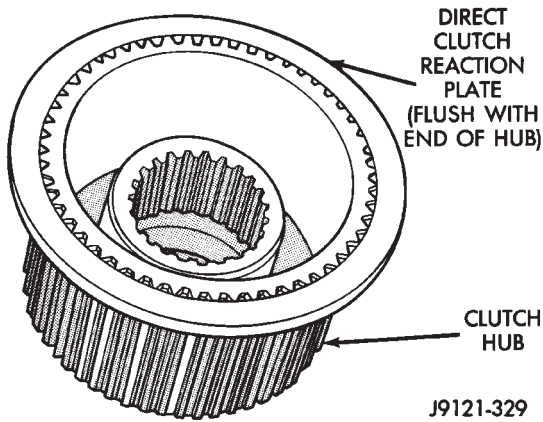
(2) Install wave spring on top of reaction ring (Fig. 239). **Reaction ring and wave ring both fit in same ring groove.** Use screwdriver to seat each ring securely in groove. Also ensure that the ends of the two rings are offset from each other.

DISASSEMBLY AND ASSEMBLY (Continued)



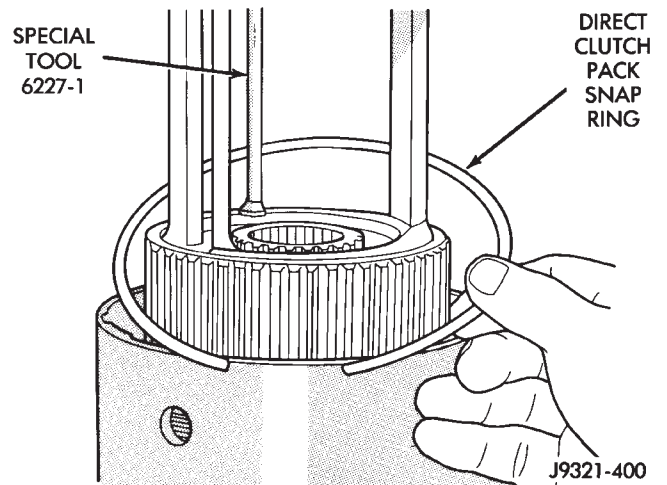
J9321-397

Fig. 229 Direct Clutch Pack And Clutch Hub Installation



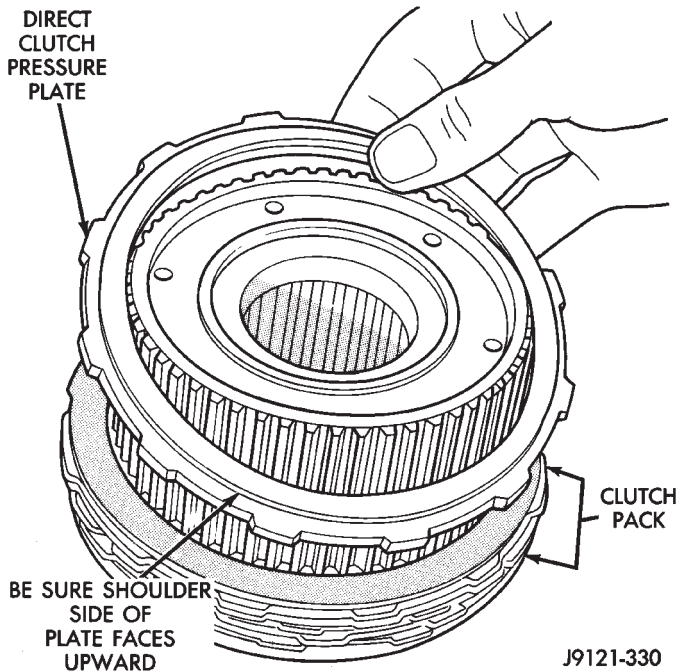
J9121-329

Fig. 227 Correct Position Of Direct Clutch Reaction Plate



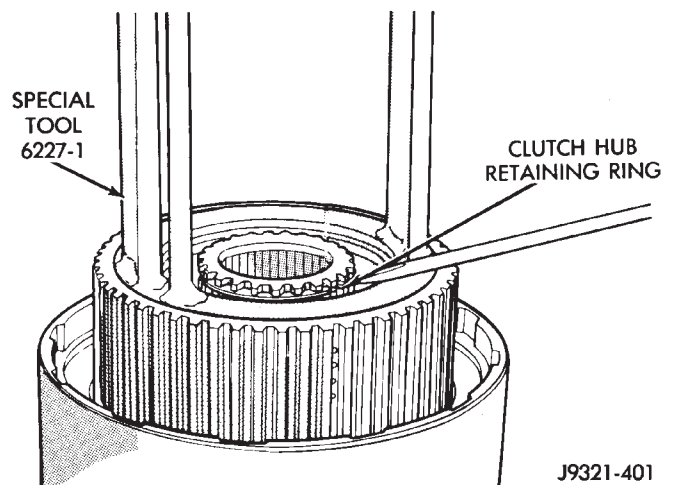
J9321-400

Fig. 230 Direct Clutch Pack Snap Ring Installation



J9121-330

Fig. 228 Correct Position Of Direct Clutch Pressure Plate



J9321-401

Fig. 231 Clutch Hub Retaining Ring Installation

DISASSEMBLY AND ASSEMBLY (Continued)

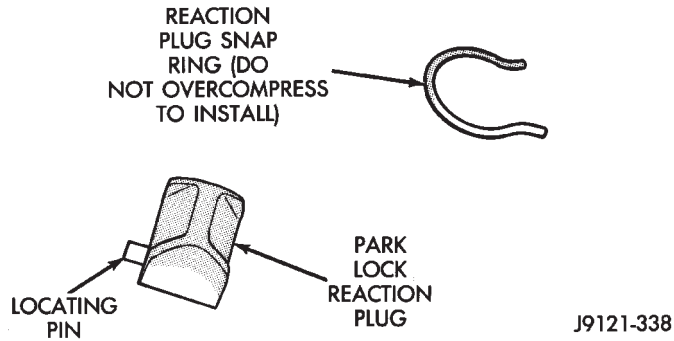


Fig. 232 Reaction Plug Locating Pin And Snap-Ring

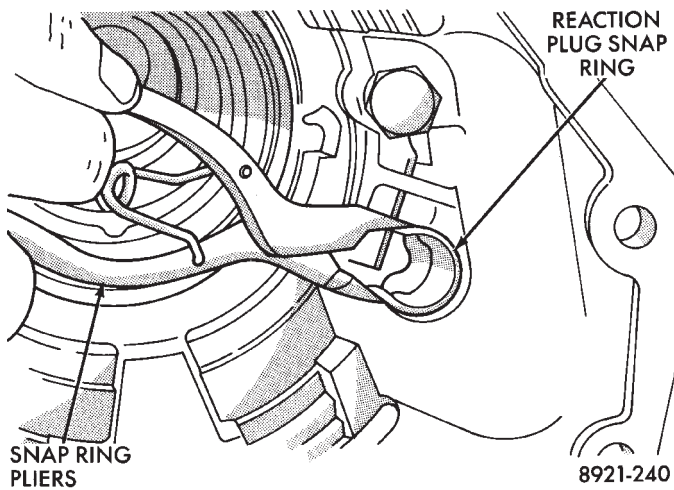


Fig. 233 Reaction Plug And Snap-Ring Installation

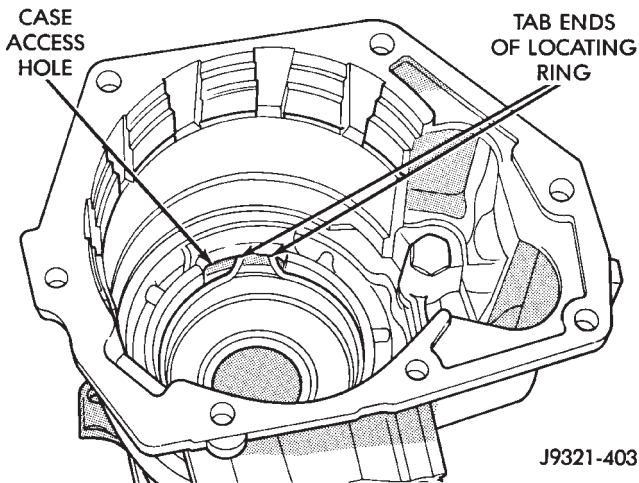


Fig. 234 Correct Rear Bearing Locating Ring Position

NOTE: The 42RE transmission has 3 overdrive clutch discs and 2 plates. The 44RE transmission has 4 overdrive clutch discs and 3 plates

- (3) Assemble overdrive clutch pack (Fig. 240).
- (4) Install overdrive clutch reaction plate first.

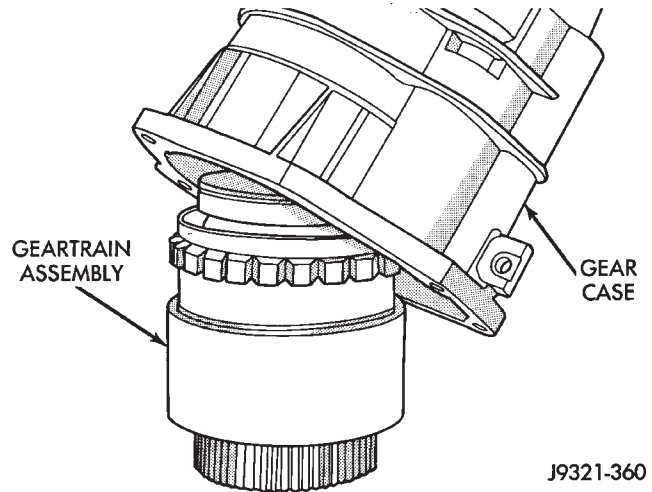


Fig. 235 Overdrive Gear Case Installation

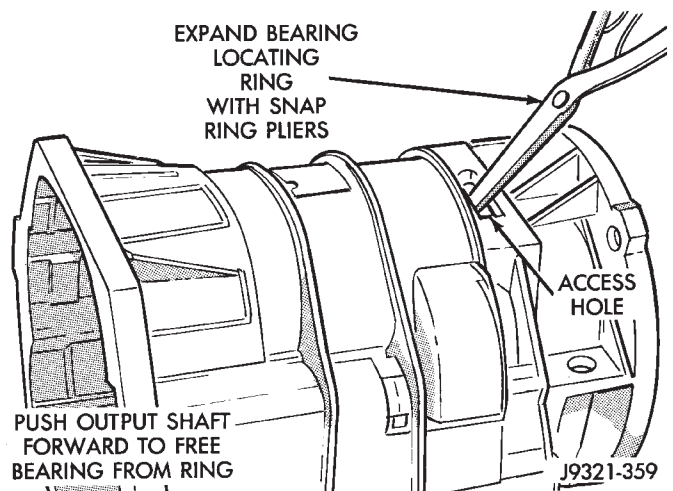


Fig. 236 Seating Locating Ring In Rear Bearing

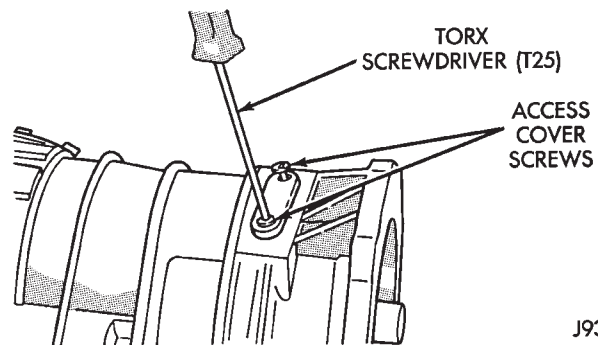


Fig. 237 Locating Ring Access Cover And Gasket Installation

- (5) Install first clutch disc followed by first clutch plate. Then install remaining clutch discs and plates in same order.
- (6) Install clutch pack pressure plate.
- (7) Install clutch pack wire-type retaining ring (Fig. 241).

DISASSEMBLY AND ASSEMBLY (Continued)

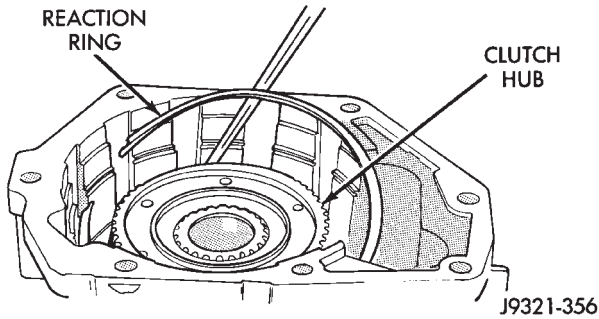


Fig. 238 Overdrive Clutch Reaction Ring Installation

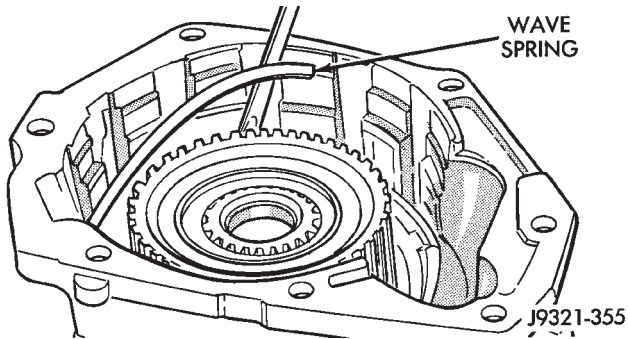


Fig. 239 Overdrive Clutch Wave Spring Installation

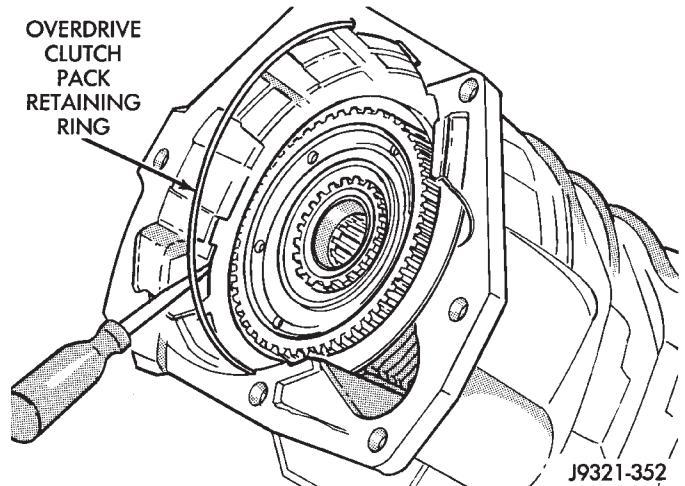


Fig. 241 Overdrive Clutch Pack Retaining Ring Installation

(2) Determine correct thickness intermediate shaft spacer as follows:

- (a) Insert Special Tool 6312 through sun gear, planetary gear and into pilot bushing in output shaft. Be sure tool bottoms against planetary shoulder.

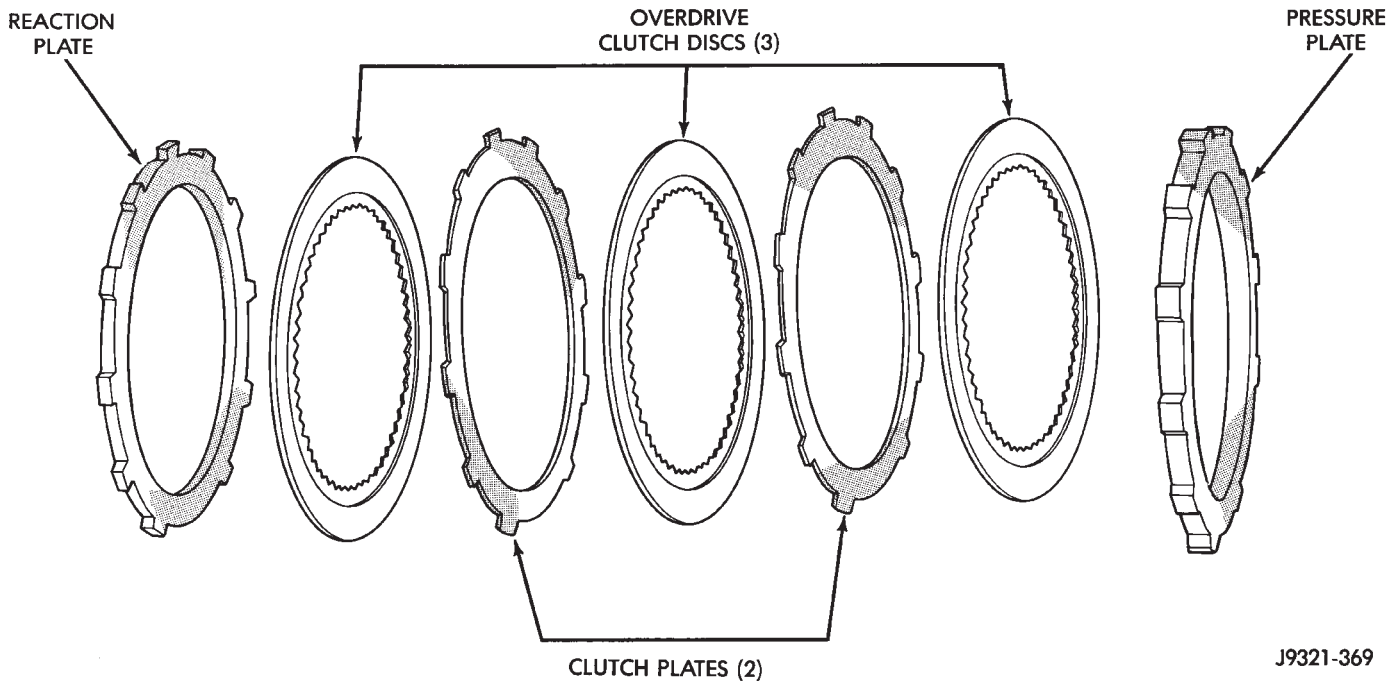


Fig. 240 42RE Overdrive Clutch Components

INTERMEDIATE SHAFT SPACER SELECTION

(1) Place overdrive unit in vertical position. Mount it on blocks, or in workbench with appropriate size mounting hole cut into it. Be sure unit is facing upward for access to direct clutch hub. Also be sure output shaft is not loaded and internal components are moved rearward for accurate measurement.

(b) Position Gauge Tool 6311 across face of overdrive case (Fig. 242). Then position Dial Caliper C-4962 over gauge tool.

(c) Extend sliding scale of dial caliper downward through gauge tool slot until scale contacts end of Gauge Alignment Tool 6312. Lock scale in place.

DISASSEMBLY AND ASSEMBLY (Continued)

Remove dial caliper tool and note distance measured (Fig. 242).

(d) Select proper thickness end play spacer from spacer chart based on distance measured (Fig. 243).

(e) Remove Gauge Alignment Tool 6312.

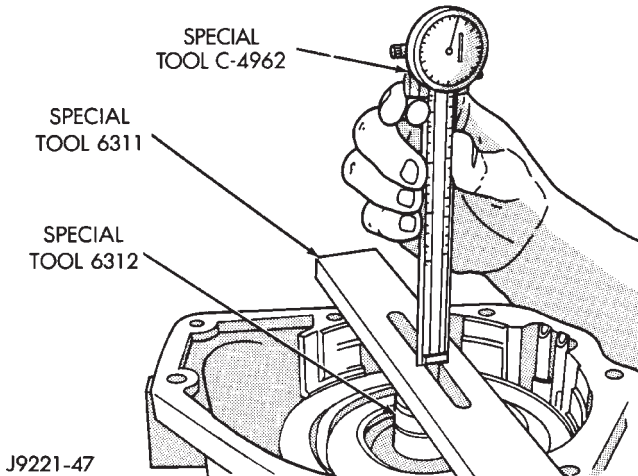


Fig. 242 Shaft End Play Measurement

End Play Measurement (Inches)	Spacer Thickness (Inches)
.7336 - .7505	.158 - .159
.7506 - .7675	.175 - .176
.7676 - .7855	.193 - .194
.7856 - .8011	.211 - .212

J9121-341

Fig. 243 Intermediate Shaft End Play Spacer Selection

OD THRUST PLATE SELECTION

(1) Place overdrive unit in vertical position. Mount it on blocks, or in workbench with appropriate size mounting hole cut into it. Be sure unit is facing upward for access to direct clutch hub. Also be sure output shaft is not loaded and internal components are moved rearward for accurate measurement.

(2) Determine correct thickness overdrive piston thrust plate as follows:

(a) Position Gauge Tool 6311 across face of overdrive case. Then position Dial Caliper C-4962 over gauge tool (Fig. 244).

(b) Measure distance to clutch hub thrust bearing seat at four points 90° apart. Then average measurements by adding them and dividing by 4.

(c) Select and install required thrust plate from information in thrust plate chart (Fig. 245).

(3) Leave Alignment Tool 6227-2 in place. Tool will keep planetary and clutch hub splines in alignment

until overdrive unit is ready for installation on transmission.

(4) Transmission speed sensor can be installed at this time if desired. However, it is recommended that sensor not be installed until after overdrive unit is secured to transmission.

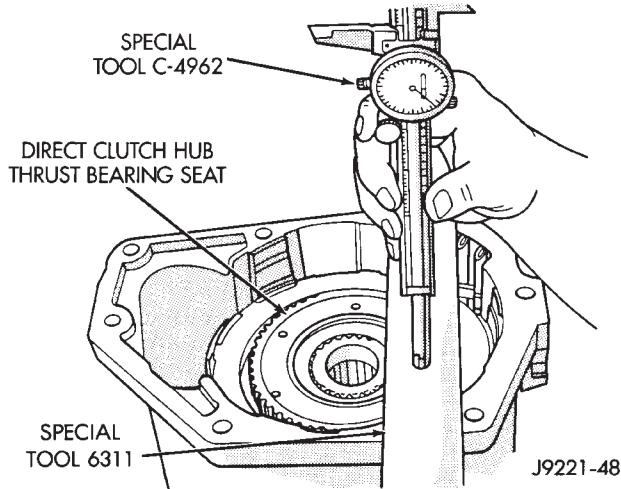


Fig. 244 Overdrive Piston Thrust Plate Measurement

End Play Measurement (Inches)	Spacer Thickness (Inches)
1.7500 - 1.7649	.108 - .110
1.7650 - 1.7799	.123 - .125
1.7800 - 1.7949	.138 - .140
1.7950 - 1.8099	.153 - .155
1.8100 - 1.8249	.168 - .170
1.8250 - 1.8399	.183 - .185
1.8400 - 1.8549	.198 - .200
1.8550 - 1.8699	.213 - .215
1.8700 - 1.8849	.228 - .230
1.8850 - 1.8999	.243 - .245

J9121-342

Fig. 245 Overdrive Piston Thrust Plate Selection
OVERDRIVE PISTON ASSEMBLY

(1) Install new seals on over drive piston.
(2) Stand transmission case upright on bellhousing.

(3) Position Guide Ring 8114-1 on outer edge of overdrive piston retainer.

(4) Position Seal Guide 8114-2 on inner edge of overdrive piston retainer.

(5) Install overdrive piston in overdrive piston retainer by: aligning locating lugs on overdrive piston to the two mating holes in retainer.

(a) Aligning locating lugs on overdrive piston to the two mating holes in retainer.

(b) Lubricate overdrive piston seals with Mopar® Door Ease, or equivalent.

DISASSEMBLY AND ASSEMBLY (Continued)

- (c) Install piston over Seal Guide 8114-2 and inside Guide Ring 8114-1.
- (d) Push overdrive piston into position in retainer.
- (e) Verify that the locating lugs entered the lug bores in the retainer.
- (6) Install intermediate shaft spacer on intermediate shaft.
- (7) Install overdrive piston thrust plate on overdrive piston.
- (8) Install overdrive piston thrust bearing on overdrive piston.
- (9) Install transmission speed sensor and O-ring seal in overdrive case (Fig. 185).

CLEANING AND INSPECTION

VALVE BODY

Clean the valve housings, valves, plugs, springs, and separator plates with a standard parts cleaning solution only. Do not use gasoline, kerosene, or any type of caustic solution.

Do not immerse any of the electrical components in cleaning solution. Clean the governor solenoid and sensor and the dual solenoid and harness assembly by wiping them off with dry shop towels only.

Dry all except the electrical parts with compressed air. Make sure all passages are clean and free from obstructions. **Do not use rags or shop towels to dry or wipe off valve body components. Lint from these materials can stick to valve body parts, interfere with valve operation, and clog filters and fluid passages.**

Wipe the governor pressure sensor and solenoid valve with dry, lint free shop towels only. The O-rings on the sensor and solenoid valve are the only serviceable components. Be sure the vent ports in the solenoid valve are open and not blocked by dirt or debris. Replace the valve and/or sensor only when DRB scan tool diagnosis indicates this is necessary. Or, if either part has sustained physical damage (dented, deformed, broken, etc.).

CAUTION: Do not turn the small screw at the end of the solenoid valve for any reason. Turning the screw in either direction will ruin solenoid calibration and result in solenoid failure. In addition, the filter on the solenoid valve is NOT serviceable. Do not try to remove the filter as this will damage the valve housing.

Inspect the throttle and manual valve levers and shafts. Do not attempt to straighten a bent shaft or correct a loose lever. Replace these components if worn, bent, loose or damaged in any way.

Inspect all of the valve body mating surfaces for scratches, nicks, burrs, or distortion. Use a straight-edge to check surface flatness. Minor scratches may be removed with crocus cloth using only very light pressure.

Minor distortion of a valve body mating surface may be corrected by smoothing the surface with a sheet of crocus cloth. Position the crocus cloth on a surface plate, sheet of plate glass or equally flat surface. If distortion is severe or any surfaces are heavily scored, the valve body will have to be replaced.

CAUTION: Many of the valves and plugs, such as the throttle valve, shuttle valve plug, 1-2 shift valve and 1-2 governor plug, are made of coated aluminum. Aluminum components are identified by the dark color of the special coating applied to the surface (or by testing with a magnet). Do not sand aluminum valves or plugs under any circumstances. This practice could damage the special coating causing the valves/plugs to stick and bind.

Inspect the valves and plugs for scratches, burrs, nicks, or scores. Minor surface scratches on steel valves and plugs can be removed with crocus cloth but **do not round off the edges of the valve or plug lands**. Maintaining sharpness of these edges is vitally important. The edges prevent foreign matter from lodging between the valves and plugs and the bore.

Inspect all the valve and plug bores in the valve body. Use a penlight to view the bore interiors. Replace the valve body if any bores are distorted or scored. Inspect all of the valve body springs. The springs must be free of distortion, warpage or broken coils.

Check the two separator plates for distortion or damage of any kind. Inspect the upper housing, lower housing, 3-4 accumulator housing, and transfer plate carefully. Be sure all fluid passages are clean and clear. Check condition of the upper housing and transfer plate check balls as well. The check balls and ball seats must not be worn or damaged.

Trial fit each valve and plug in its bore to check freedom of operation. When clean and dry, the valves and plugs should drop freely into the bores.

Valve body bores do not change dimensionally with use. If the valve body functioned correctly when new, it will continue to operate properly after cleaning and inspection. It should not be necessary to replace a valve body assembly unless it is damaged in handling.

The only serviceable valve body components are listed below. The remaining valve body components are serviced only as part of a complete valve body assembly. Serviceable parts are:

CLEANING AND INSPECTION (Continued)

- dual solenoid and harness assembly
- solenoid gasket
- solenoid case connector O-rings and shoulder bolt
- switch valve and spring
- pressure adjusting screw and bracket assembly
- throttle lever
- manual lever and shaft seal
- throttle lever shaft seal, washer, and E-clip
- fluid filter and screws
- detent ball and spring
- valve body screws
- governor pressure solenoid
- governor pressure sensor and retaining clip
- park lock rod and E-clip

TRANSMISSION

GENERAL INFORMATION

Inspect the transmission bushings during overhaul. Bushing condition is important as worn, scored bushings contribute to low pressures, clutch slip and accelerated wear of other components. However, do not replace bushings as a matter of course. Replace bushings only when they are actually worn, or scored.

Use recommended tools to replace bushings. The tools are sized and designed to remove, install, and seat bushings correctly. The bushing replacement tools are included in Bushing Tool Set C-3887-B.

Pre-sized service bushings are available for replacement purposes. Only the sun gear bushings are not serviced. Low cost of the sun gear assembly makes it easier to simply replace the gear and bushings as an assembly.

Heli-Coil inserts can be used to repair damaged, stripped or worn threads in aluminum parts. These inserts are available from most automotive parts suppliers. Stainless steel inserts are recommended.

The use of crocus cloth is permissible where necessary, providing it is used carefully. When used on shafts, or valves, use extreme care to avoid rounding off sharp edges. Sharp edges are vital as they prevent foreign matter from getting between the valve and valve bore.

Do not reuse oil seals, gaskets, seal rings, or O-rings during overhaul. Replace these parts as a matter of course. Also do not reuse snap rings or E-clips that are bent or distorted. Replace these parts as well.

Lubricate transmission parts with Mopar® ATF Plus, Type 7176, transmission fluid during overhaul and assembly. Use petroleum jelly, Mopar® Door Ease, or Ru-Glyde to prelubricate seals, O-rings, and thrust washers. Petroleum jelly can also be used to hold parts in place during reassembly.

TRANSMISSION CASE CLEANING AND INSPECTION

Clean the case in a solvent tank. Flush the case bores and fluid passages thoroughly with solvent. Dry the case and all fluid passages with compressed air. Be sure all solvent is removed from the case and that all fluid passages are clear.

NOTE: Do not use shop towels or rags to dry the case (or any other transmission component) unless they are made from lint-free materials. Lint will stick to case surfaces and transmission components and circulate throughout the transmission after assembly. A sufficient quantity of lint can block fluid passages and interfere with valve body operation.

Inspect the case for cracks, porous spots, worn bores, or damaged threads. Damaged threads can be repaired with Helicoil thread inserts. However, the case will have to be replaced if it exhibits any type of damage or wear.

Lubricate the front band adjusting screw threads with petroleum jelly and thread the screw part-way into the case. Be sure the screw turns freely.

OVERRUNNING CLUTCH/LOW-REVERSE DRUM/OVERDRIVE PISTON RETAINER

Clean the overrunning clutch assembly, clutch cam, low-reverse drum, and overdrive piston retainer in solvent. Dry them with compressed air after cleaning.

Inspect condition of each clutch part after cleaning. Replace the overrunning clutch roller and spring assembly if any rollers or springs are worn or damaged, or if the roller cage is distorted, or damaged. Replace the cam if worn, cracked or damaged.

Replace the low-reverse drum if the clutch race, roller surface or inside diameter is scored, worn or damaged. **Do not remove the clutch race from the low-reverse drum under any circumstances. Replace the drum and race as an assembly if either component is damaged.**

Examine the overdrive piston retainer carefully for wear, cracks, scoring or other damage. Be sure the retainer hub is a snug fit in the case and drum. Replace the retainer if worn or damaged.

ACCUMULATOR

Inspect the accumulator piston and seal rings (Fig. 246). Replace the seal rings if worn or cut. Replace the piston if chipped or cracked.

Check condition of the accumulator inner and outer springs (Fig. 246). Replace the springs if the coils are cracked, distorted or collapsed.

CLEANING AND INSPECTION (Continued)

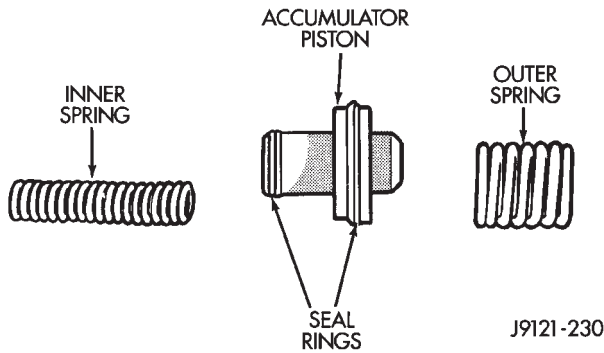


Fig. 246 Accumulator Components

FRONT SERVO

Clean the servo piston components with solvent and dry them with compressed air. Wipe the band clean with lint free shop towels.

Replace the front band if distorted, lining is burned, flaking off, or worn to the point where the grooves in the lining material are no longer visible.

Inspect the servo components. Replace the springs if collapsed, distorted or broken. Replace the guide, rod and piston if cracked, bent, or worn. Discard the servo snap ring if distorted or warped.

Check the servo piston bore for wear. If the bore is severely scored, or damaged, it will be necessary to replace the case.

Replace any servo component if doubt exists about condition. Do not reuse suspect parts.

REAR SERVO

Remove and discard the servo piston seal ring (Fig. 247). Then clean the servo components with solvent and dry with compressed air. Replace either spring if collapsed, distorted or broken. Replace the plug and piston if cracked, bent, or worn. Discard the servo snap rings and use a new ones at assembly.

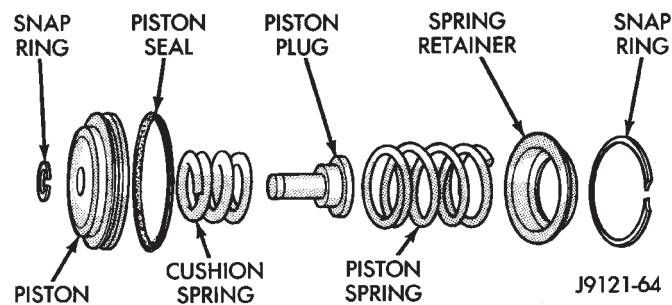


Fig. 247 Rear Servo Components

OIL PUMP AND REACTION SHAFT SUPPORT

(1) Clean pump and support components with solvent and dry them with compressed air.

(2) Check condition of the seal rings and thrust washer on the reaction shaft support. The seal rings

do not need to be replaced unless cracked, broken, or severely worn.

(3) Inspect the pump and support components. Replace the pump or support if the seal ring grooves or machined surfaces are worn, scored, pitted, or damaged. Replace the pump gears if pitted, worn chipped, or damaged.

(4) Inspect the pump bushing. Then check the reaction shaft support bushing. Replace either bushing only if heavily worn, scored or damaged. It is not necessary to replace the bushings unless they are actually damaged.

(5) Install the gears in the pump body and measure pump component clearances as follows:

(a) Clearance between outer gear and reaction shaft housing should be 0.010 to 0.063 mm (0.0004 to 0.0025 in.). Clearance between inner gear and reaction shaft housing should be 0.010 to 0.063 mm (0.0004 to 0.0025 in.). Both clearances can be measured at the same time by:

(I) Installing the pump gears in the pump housing.

(II) Position an appropriate piece of Plastigage™ across both gears.

(III) Align the plastigage to a flat area on the reaction shaft housing.

(IV) Install the reaction shaft to the pump housing.

(V) Separate the reaction shaft housing from the pump housing and measure the Plastigage™ following the instructions supplied with it.

(b) Clearance between inner gear tooth and outer gear should be 0.08 to 0.19 mm (0.0035 to 0.0075 in.). Measure clearance with an appropriate feeler gauge.

(c) Clearance between outer gear and pump housing should also be 0.010 to 0.19 mm (0.0035 to 0.0075 in.). Measure clearance with an appropriate feeler gauge.

FRONT CLUTCH

Clean and inspect the front clutch components. Replace the clutch discs if warped, worn, scored, burned or charred, or if the facing is flaking off. Replace the steel plates if heavily scored, warped, or broken. Be sure the driving lugs on the plates are in good condition. The lugs must not be bent, cracked or damaged in any way.

Replace the clutch spring and spring retainer if either is distorted, warped or broken.

Check the lug grooves in the clutch retainer. The steel plates should slide freely in the slots. Replace the retainer if the grooves are worn or damaged.

Check action of the check ball in the retainer (Fig. 248). The ball must move freely and not stick.

CLEANING AND INSPECTION (Continued)

NOTE: Inspect the clutch retainer bushings carefully (Fig. 249). The retainer bushings are **NOT** serviceable. It will be necessary to replace the retainer if either bushing is scored, or worn.

Inspect the piston and retainer seal surfaces for nicks or scratches. Minor scratches can be removed with crocus cloth. However, replace the piston and/or retainer if the seal surfaces are seriously scored.

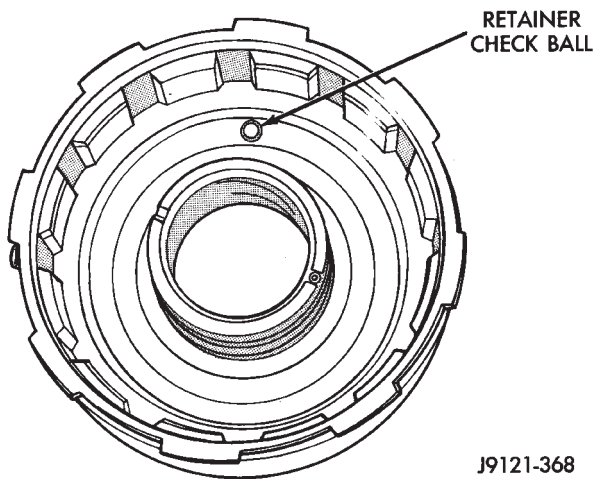


Fig. 248 Front Clutch Piston Retainer Check Ball Location

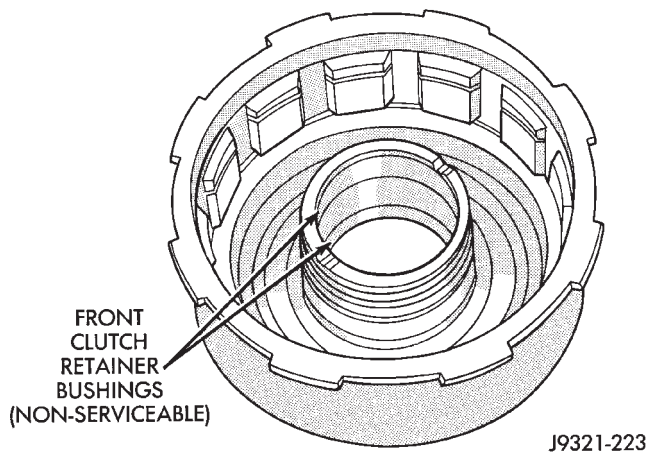


Fig. 249 Retainer Bushing Location/Inspection

REAR CLUTCH

Clean the clutch components with solvent and dry them with compressed air. Do not use rags or shop towels to dry any of the clutch parts. Lint from such materials will adhere to component surfaces and could restrict or block fluid passages after assembly.

Replace the clutch discs if warped, worn, scored, burned/charred, the lugs are damaged, or if the facing is flaking off. Replace the top and bottom pressure plates if scored, warped, or cracked. Be sure the driving lugs on the pressure and clutch plates are

also in good condition. The lugs must not be bent, cracked or damaged in any way.

Replace the piston spring and wave spring if either part is distorted, warped or broken.

Check the lug grooves in the clutch retainer. The clutch and pressure plates should slide freely in the slots. Replace the retainer if the grooves are worn or damaged. Also check action of the check balls in the retainer and piston. Each check ball must move freely and not stick.

Replace the retainer bushing if worn, scored, or doubt exists about bushing condition.

Inspect the piston and retainer seal surfaces for nicks or scratches. Minor scratches can be removed with crocus cloth. However, replace the piston and/or retainer if the seal surfaces are seriously scored.

Check condition of the fiber thrust washer and metal output shaft thrust washer. Replace either washer if worn or damaged.

Check condition of the seal rings on the input shaft and clutch retainer hub. Replace the seal rings only if worn, distorted, or damaged. The input shaft front seal ring is teflon with chamfered ends. The rear ring is metal with interlocking ends.

Check the input shaft for wear, or damage. Replace the shaft if worn, scored or damaged in any way.

PLANETARY GEARTRAIN

Clean the planetary components in solvent and dry them with compressed air.

Check sun gear and driving shell condition. Replace the gear if damaged or if the bushings are scored or worn. The bushings are not serviceable. Replace the driving shell if worn, cracked or damaged.

Replace planetary gear sets if gears, pinion pins, or carrier are damaged in any way. Replace the annulus gears and supports if either component is worn or damaged.

Inspect the geartrain spacers, thrust plates, snap rings, and thrust washers. Replace any of these parts that are worn, distorted or damaged. Do not attempt to reuse these parts.

The planetary gear thrust washers are different sizes. The large diameter washers go on the front planetary and the smaller washers go on the rear planetary. All the washers have four locating tabs on them. These tabs fit in the holes or slots provided in each planetary gear.

Inspect the output shaft carefully. Pay particular attention to the machined bushing/bearing surfaces on the shaft and the governor valve shaft bore at the shaft rear.

Replace the output shaft if the machined surfaces are scored, pitted, or damaged in any way. Also replace the shaft if the splines are damaged, or

CLEANING AND INSPECTION (Continued)

exhibits cracks at any location (especially at the governor valve shaft bore).

The annulus gears can be removed from their supports if necessary. Just remove the snap rings and separate the two parts when replacement is necessary. In addition, the annulus gear bushings can be replaced if severely worn, or scored. However it is not necessary to replace the bushings if they only exhibit normal wear. Check bushing fit on the output shaft to be sure.

OVERDRIVE UNIT

Clean the geartrain and case components with solvent. Dry all parts except the bearings with compressed air. Allow bearings to air dry.

Do not use shop towels for wiping parts dry unless the towels are made from a lint-free material. A sufficient quantity of lint (from shop towels, cloths, rags, etc.) could plug the transmission filter and fluid passages.

Discard the old case gasket and seals. Do not attempt to salvage these parts. They are not reusable. Replace any of the overdrive unit snap rings if distorted or damaged.

Minor nicks or scratches on components can be smoothed with crocus cloth. However, do not attempt to reduce severe scoring on any components with abrasive materials. Replace severely scored components; do not try to salvage them.

Check condition of the park lock components and the overdrive case.

Replace the case if cracked, scored, or damaged. Replace the park lock pawl, plug, or spring if worn or damaged. Be sure the bullet at the end of the park lock rod is in good condition. Replace the rod if the bullet is worn or the rod itself is bent or distorted. Do not attempt to straighten the rod.

Check the bushings in the overdrive case. Replace the bushings if severely scored or worn. Also replace the case seal if loose, distorted, or damaged.

Examine the overdrive and direct clutch discs and plates. Replace the discs if the facing is worn, severely scored, or burned and flaking off. Replace the clutch plates if worn, heavily scored, or cracked. Check the lugs on the clutch plates for wear. The plates should slide freely in the drum. Replace the plates or drum if binding occurs.

Check condition of the annulus gear, direct clutch hub, clutch drum and clutch spring. Replace the gear, hub and drum if worn or damaged. Replace the spring if collapsed, distorted, or cracked.

Be sure the splines and lugs on the gear, drum and hub are in good condition. The clutch plates and discs should slide freely in these components.

Inspect the thrust bearings and spring plate. Replace the plate if worn or scored. Replace the bearings if rough, noisy, brinnelled, or worn.

Inspect the planetary gear assembly and the sun gear and bushings. If either the sun gear or the bushings are damaged, replace the gear and bushings as an assembly. The gear and bushings are not serviced separately.

The planetary carrier and pinions must be in good condition. Also be sure the pinion pins are secure and in good condition. Replace the carrier if worn or damaged.

Inspect the overrunning clutch and race. The race surface should be smooth and free of scores. Replace the overrunning clutch assembly or the race if either assembly is worn or damaged in any way.

Inspect the output shaft and governor components. Replace the shaft pilot bushing and inner bushing if damaged. Replace either shaft bearing if rough or noisy. Replace the bearing snap rings if distorted or cracked.

Check the machined surfaces on the output shaft. These surfaces should be clean and smooth. Very minor nicks or scratches can be smoothed with crocus cloth. Replace the shaft if worn, scored or damaged in any way.

Inspect the output shaft bushings. The small bushing is the intermediate shaft pilot bushing. The large bushing is the overrunning clutch hub bushing. Replace either bushing if scored, pitted, cracked, or worn.

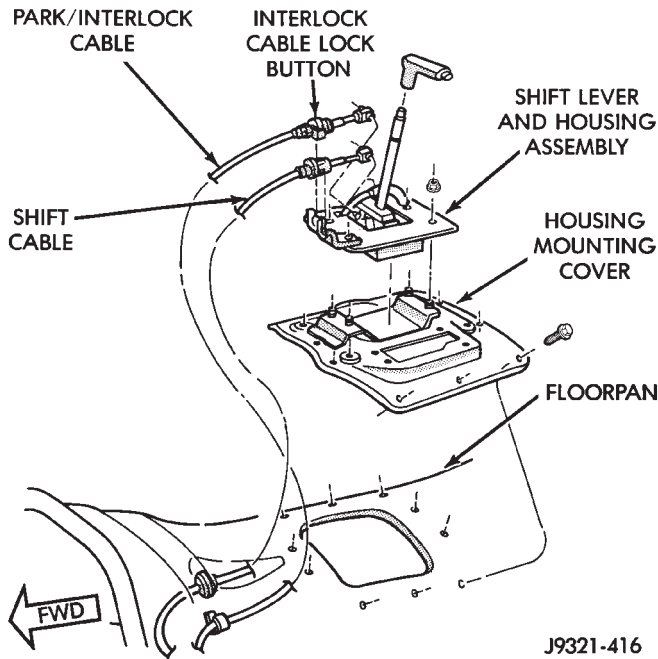
ADJUSTMENTS

BRAKE TRANSMISSION SHIFT INTERLOCK

The park interlock cable is part of the brake/shift lever interlock system. Correct cable adjustment is important to proper interlock operation. The gear shift and park lock cables must both be correctly adjusted in order to shift out of Park.

Park Interlock Cable Adjustment Procedure

- (1) Shift into Park position.
- (2) Turn ignition switch to Accessory position. **Be sure ignition key cylinder is in Accessory position. Cable will not adjust correctly in any other position.**
- (3) Remove shift lever bezel and console screws. Raise bezel and console for access to park interlock cable.
- (4) Pull cable lock button up to release cable (Fig. 250).
- (5) Pull cable forward. Then release cable and press lock button down until it snaps in place.

ADJUSTMENTS (Continued)

J9321-416

Fig. 250 Shift And Park Lock Cables**BTSI FUNCTION CHECK**

(1) Verify removal of ignition key allowed in park position only.

(2) When the shift lever is in park, and the shift handle push-button is in the out position, the ignition key cylinder should rotate freely from off to lock. When the shifter is in any other position, the ignition key should not rotate from off to lock.

(3) Shifting out of park should be possible when the ignition key cylinder is in the off position.

(4) Shifting out of park should not be possible while applying 25 lb. max. handle push-button force, and ignition key cylinder is in the run or start positions, unless the foot brake pedal is depressed approximately 1/2 inch (12mm).

(5) Shifting out of park should not be possible when the ignition key cylinder is in the accessory or lock position.

(6) Shifting between any gears neutral or park may be done without depressing foot brake with ignition switch in run or start positions and vehicle stationary or in motion.

(7) The floorshifter lever and gate positions should be in alignment with all transmission detent positions.

(8) Engine starts must be possible with floorshifter lever in park or neutral gate positions only. Engine starts must not be possible in any other gate positions other than park or neutral.

(9) With floorshifter lever handle push-button not depressed and lever detent in:

- PARK POSITION- apply forward force on center of handle and remove pressure. Engine start must be possible.

- PARK POSITION- apply rearward force on center of handle and remove pressure. Engine start must be possible.

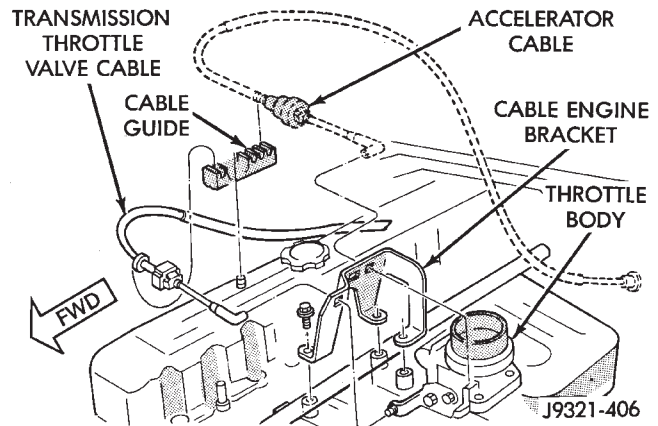
- NEUTRAL POSITION- engine start must be possible.

- NEUTRAL POSITION, ENGINE RUNNING AND BRAKES APPLIED- Apply forward force on center of shift handle. Transmission should not be able to shift into reverse detent.

TRANSMISSION THROTTLE VALVE CABLE ADJUSTMENT

The transmission throttle valve is operated by a cam on the throttle lever. The throttle lever is operated by an adjustable cable (Fig. 251). The cable is attached to an arm mounted on the throttle lever shaft. A retaining clip at the engine-end of the cable is removed to provide for cable adjustment. The retaining clip is then installed back onto the throttle valve cable to lock in the adjustment.

A correctly adjusted throttle valve cable will cause the throttle lever on the transmission to move simultaneously with the throttle body lever from the idle position. Proper adjustment will allow simultaneous movement without causing the transmission throttle lever to either move ahead of, or lag behind the lever on the throttle body.



J9321-406

Fig. 251 Throttle Cable Attachment At Engine**Checking Throttle Valve Cable Adjustment**

- (1) Turn ignition key to OFF position.
- (2) Remove air cleaner.
- (3) Verify that lever on throttle body is at curb idle position. Then verify that transmission throttle lever (Fig. 252) is also at idle (fully forward) position.
- (4) Slide cable off attachment stud on throttle body lever.
- (5) Compare position of cable end to attachment stud on throttle body lever:

ADJUSTMENTS (Continued)

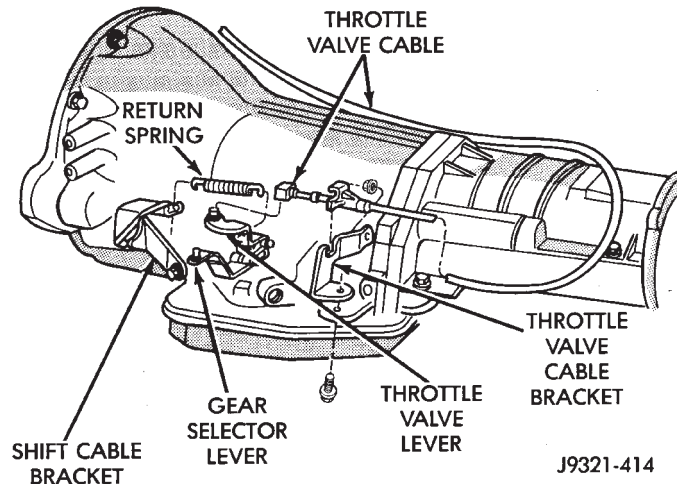


Fig. 252 Throttle Cable Attachment At Transmission

- Cable end and attachment stud should be aligned (or centered on one another) to within 1 mm (0.039 in.) in either direction.

- If cable end and attachment stud are misaligned (off center), cable will have to be adjusted as described in Throttle Valve Cable Adjustment procedure.

(6) Reconnect cable end to attachment stud. Then with aid of a helper, observe movement of transmission throttle lever and lever on throttle body.

- If both levers move simultaneously from idle to half-throttle and back to idle position, adjustment is correct.

- If transmission throttle lever moves ahead of, or lags behind throttle body lever, cable adjustment will be necessary. Or, if throttle body lever prevents transmission lever from returning to closed position, cable adjustment will be necessary.

Throttle Valve Cable Adjustment Procedure

- (1) Turn ignition switch to OFF position.
- (2) Remove air cleaner if necessary.
- (3) Disconnect cable end from attachment stud.

Carefully slide cable off stud. Do not pry or pull cable off.

(4) Verify that transmission throttle lever is in fully closed position. Then be sure lever on throttle body is at curb idle position.

(5) Insert a small screwdriver under edge of retaining clip and remove retaining clip.

(6) Center cable end on attachment stud to within 1 mm (0.039 in.).

(7) Install retaining clip onto cable housing.

(8) Check cable adjustment. Verify transmission throttle lever and lever on throttle body move simultaneously.

GEARSHIFT CABLE

Check adjustment by starting the engine in Park and Neutral. Adjustment is OK if the engine starts only in these positions. Adjustment is incorrect if the engine starts in one but not both positions. If the engine starts in any position other than Park or Neutral, or if the engine will not start at all, the park/neutral position switch may be faulty.

Gearshift Adjustment Procedure

- (1) Shift transmission into Park.
- (2) Raise vehicle.
- (3) Release cable adjuster clamp (at transmission end of cable) to unlock cable.
- (4) Unsnap cable from cable mounting bracket on transmission (Fig. 253).
- (5) Slide cable eyelet off transmission shift lever.
- (6) Verify transmission shift lever is in Park detent by moving lever fully rearward. Last rearward detent is Park position.
- (7) Verify positive engagement of transmission park lock by attempting to rotate propeller shaft. Shaft will not rotate when park lock is engaged.
- (8) Slide cable eyelet onto transmission shift lever.
- (9) Snap shift cable adjuster into mounting bracket on transmission.
- (10) Lock shift cable by pressing cable adjuster clamp down until it snaps into place.
- (11) Lower vehicle and check engine starting. Engine should start only in Park and Neutral.

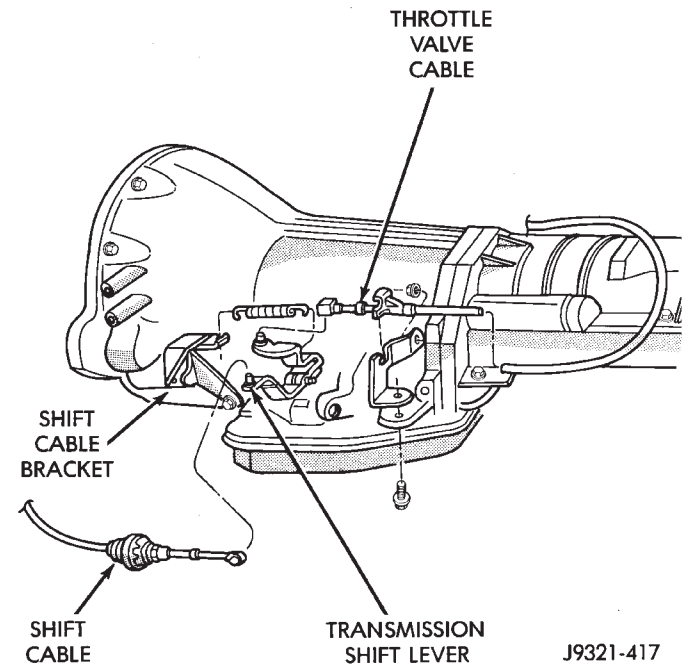


Fig. 253 Shift Cable Attachment At Transmission—Typical

ADJUSTMENTS (Continued)**BAND ADJUSTMENTS****FRONT BAND ADJUSTMENT**

The front (kickdown) band adjusting screw is located on the left side of the transmission case above the manual valve and throttle valve levers.

- (1) Raise vehicle.
- (2) Loosen band adjusting screw locknut (Fig. 254). Then back locknut off 3-5 turns. Be sure adjusting screw turns freely in case. Apply lubricant to screw threads if necessary.
- (3) Tighten band adjusting screw to 8 N·m (72 in. lbs.) torque with Inch Pound Torque Wrench C-3380-A, a 3-in. extension and 5/16 socket.

CAUTION: If Adapter C-3705 is needed to reach the adjusting screw (Fig. 255), tighten the screw to only 5 N·m (47-50 in. lbs.) torque.

42RE TRANSMISSION

- Back off front band adjusting screw 3-5/8 turns.
- Hold adjuster screw in position and tighten locknut to 41 N·m (30 ft. lbs.) torque.

44RE TRANSMISSION

- Back off front band adjusting screw 2-1/4 turns.
 - Hold adjuster screw in position and tighten locknut to 41 N·m (30 ft. lbs.) torque.
- (4) Lower vehicle.

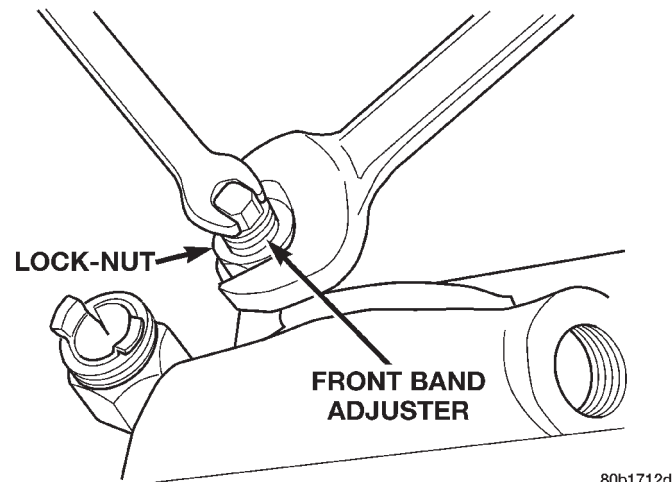
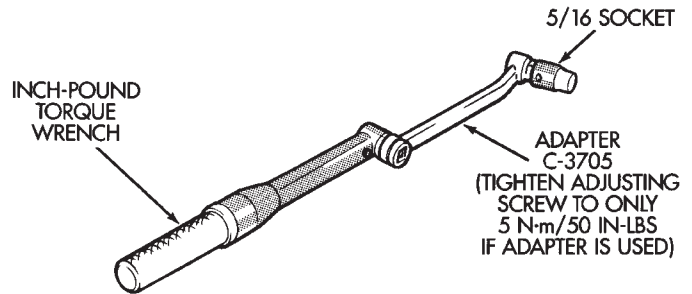


Fig. 254 Front Band Adjustment Screw Location

REAR BAND ADJUSTMENT

The transmission oil pan must be removed for access to the rear band adjusting screw.

- (1) Raise vehicle.
- (2) Remove transmission oil pan and drain fluid.
- (3) Loosen band adjusting screw locknut 5-6 turns (Fig. 256). Be sure adjusting screw turns freely in lever.



J9121-233

Fig. 255 Band Adjustment Adapter Tool

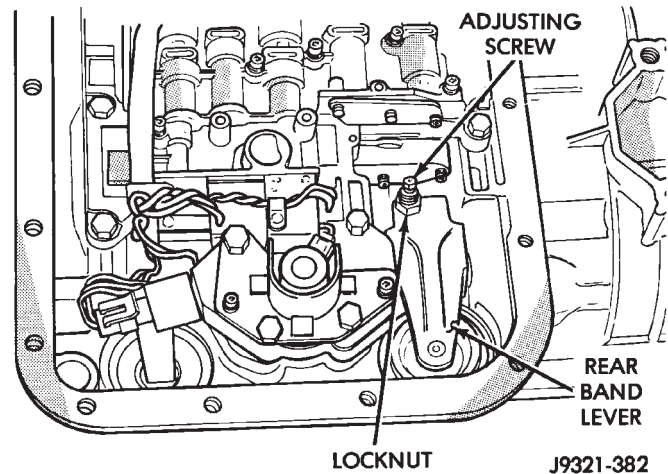


Fig. 256 Rear Band Adjusting Screw Location

- (4) Tighten adjusting screw to 8 N·m (72 in. lbs.) torque.

42/44RE TRANSMISSION

- Back off adjusting screw 4 turns.
 - Hold adjusting screw in place and tighten locknut to 34 N·m (25 ft. lbs.) torque.
- (5) Position new gasket on oil pan and install pan on transmission. Tighten pan bolts to 17 N·m (13 ft. lbs.) torque.
 - (6) Lower vehicle and refill transmission with Mopar® ATF Plus 3, Type 7176 fluid.

VALVE BODY**CONTROL PRESSURE ADJUSTMENTS**

There are two control pressure adjustments on the valve body;

- Line Pressure
- Throttle Pressure

Line and throttle pressures are interdependent because each affects shift quality and timing. As a result, both adjustments must be performed properly and in the correct sequence. Adjust line pressure first and throttle pressure last.

ADJUSTMENTS (Continued)

LINE PRESSURE ADJUSTMENT

Measure distance from the valve body to the inner edge of the adjusting screw with an accurate steel scale (Fig. 257).

Distance should be 33.4 mm (1-5/16 in.).

If adjustment is required, turn the adjusting screw in, or out, to obtain required distance setting.

NOTE: The 33.4 mm (1-5/16 in.) setting is an approximate setting. Manufacturing tolerances may make it necessary to vary from this dimension to obtain desired pressure.

One complete turn of the adjusting screw changes line pressure approximately 1-2/3 psi (9 kPa).

Turning the adjusting screw counterclockwise increases pressure while turning the screw clockwise decreases pressure.

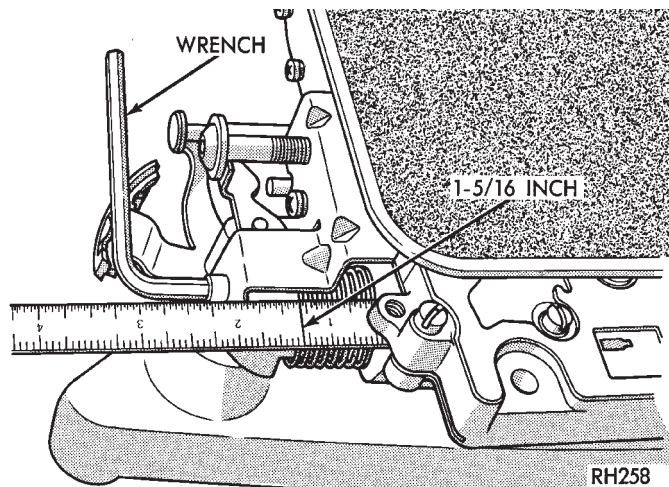


Fig. 257 Line Pressure Adjustment

THROTTLE PRESSURE ADJUSTMENT

Insert Gauge Tool C-3763 between the throttle lever cam and the kickdown valve stem (Fig. 258).

Push the gauge tool inward to compress the kickdown valve against the spring and bottom the throttle valve.

Maintain pressure against kickdown valve spring. Turn throttle lever stop screw until the screw head touches throttle lever tang and the throttle lever cam touches gauge tool.

NOTE: The kickdown valve spring must be fully compressed and the kickdown valve completely bottomed to obtain correct adjustment.

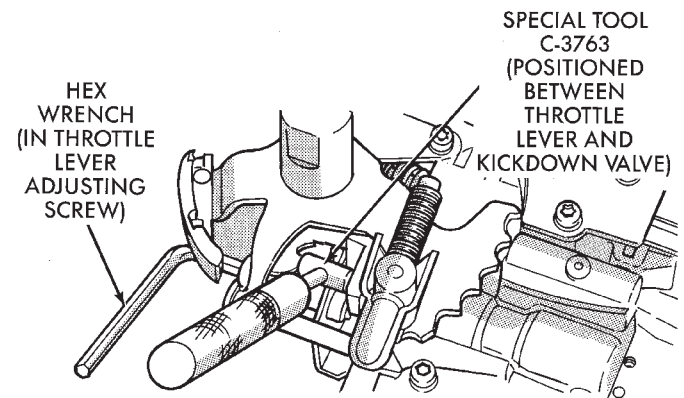
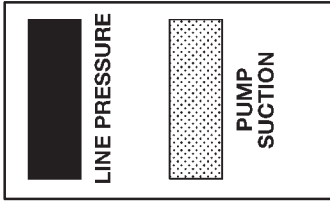
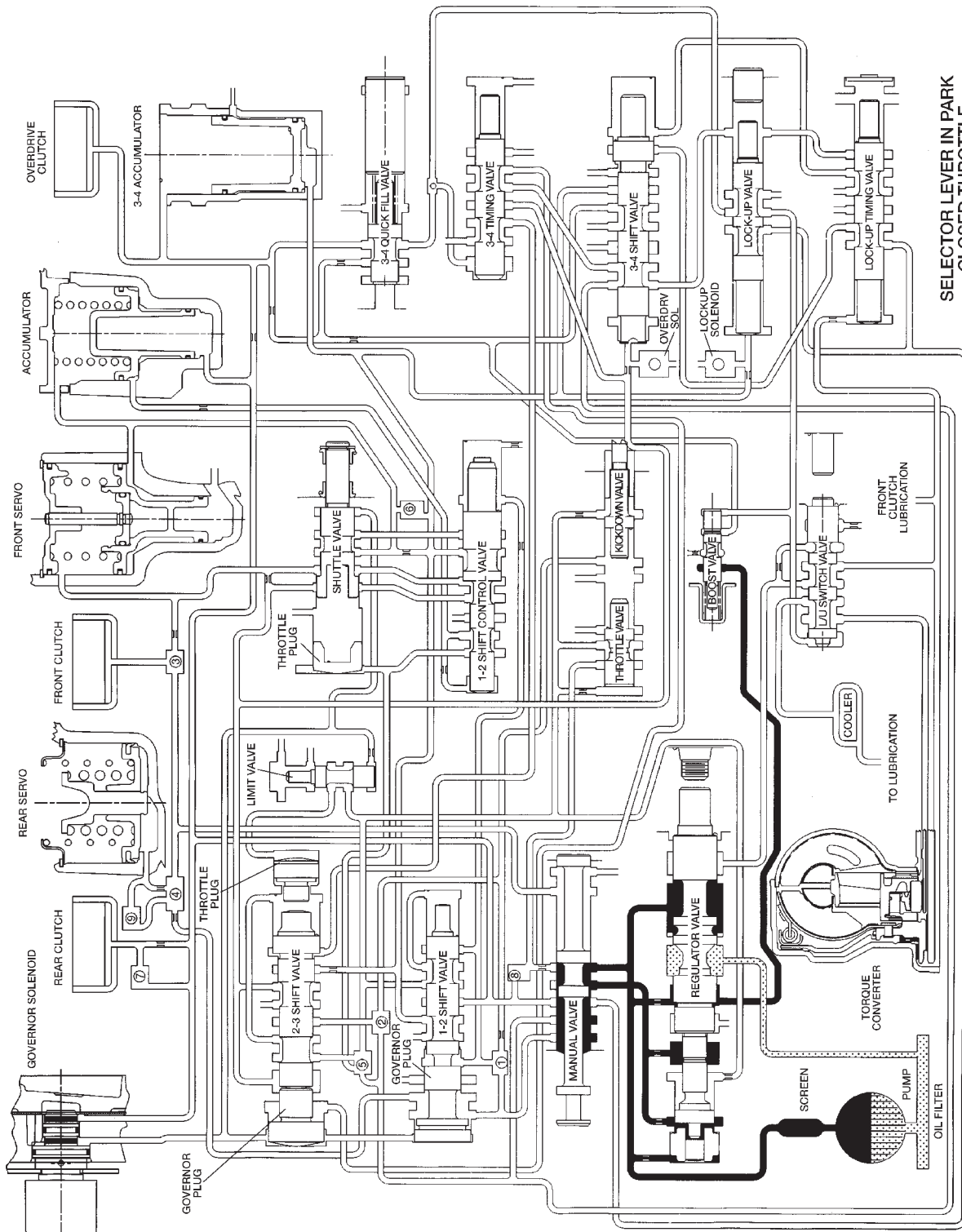


Fig. 258 Throttle Pressure Adjustment

SCHEMATICS AND DIAGRAMS
HYDRAULIC SCHEMATICS

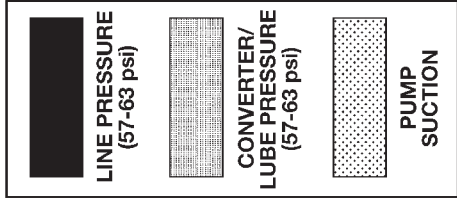


80abtd7e

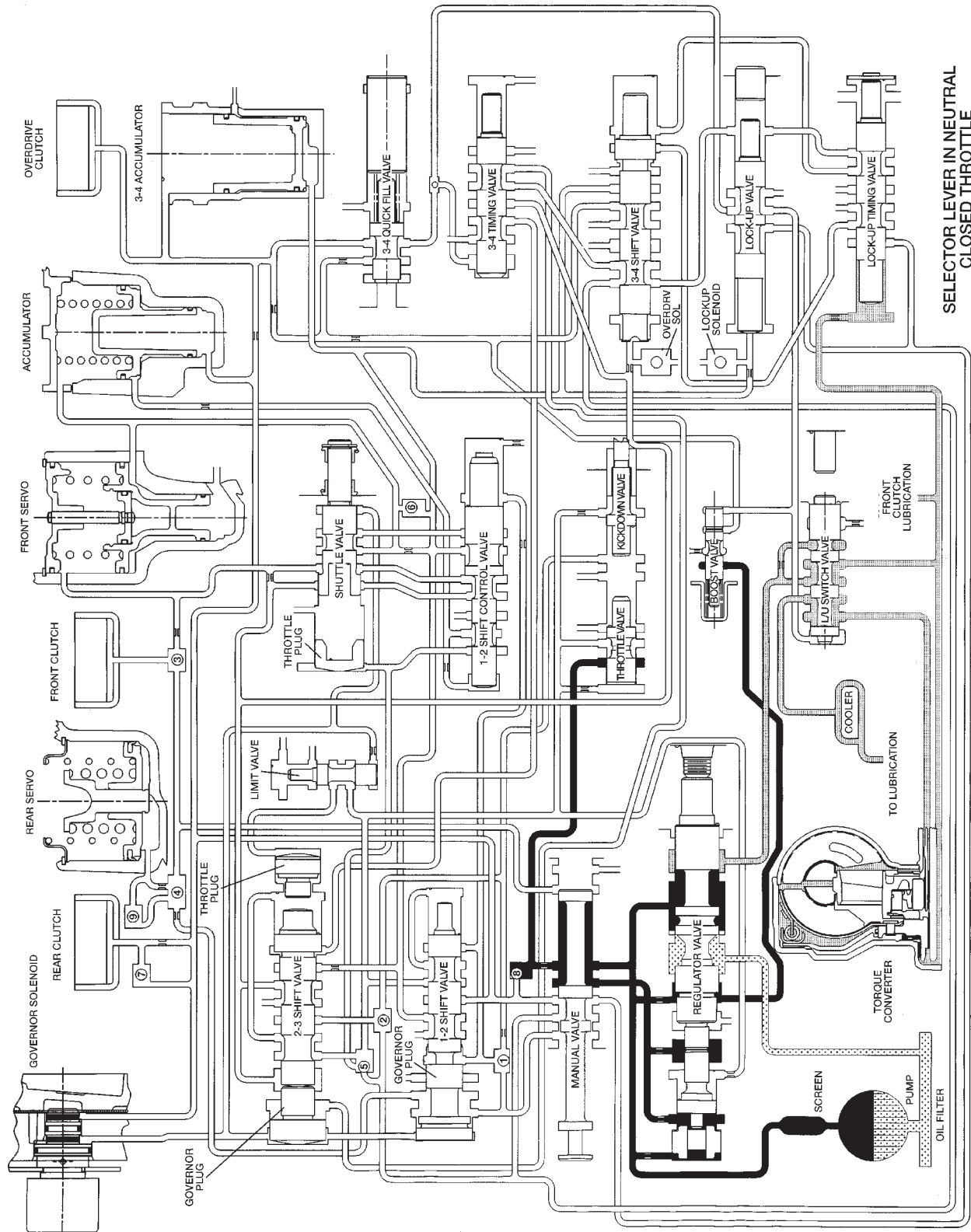


HYDRAULIC FLOW IN PARK

SCHEMATICS AND DIAGRAMS (Continued)



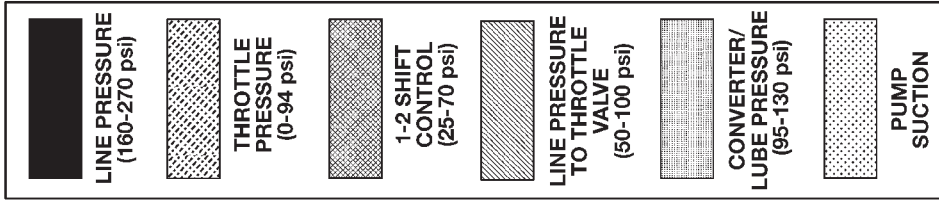
80abrd7f



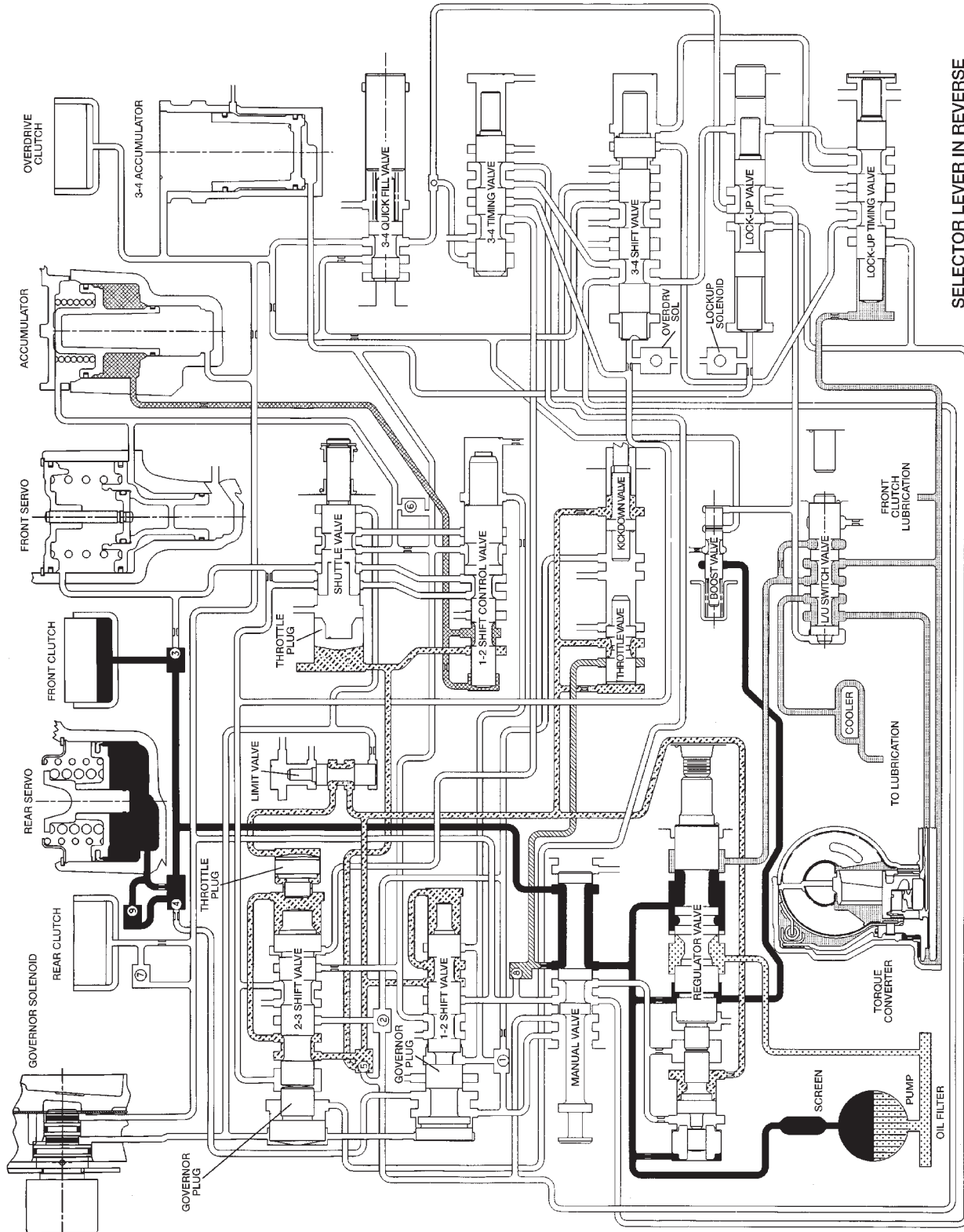
SELECTOR LEVER IN NEUTRAL
CLOSED THROTTLE

HYDRAULIC FLOW IN NEUTRAL

SCHEMATICS AND DIAGRAMS (Continued)



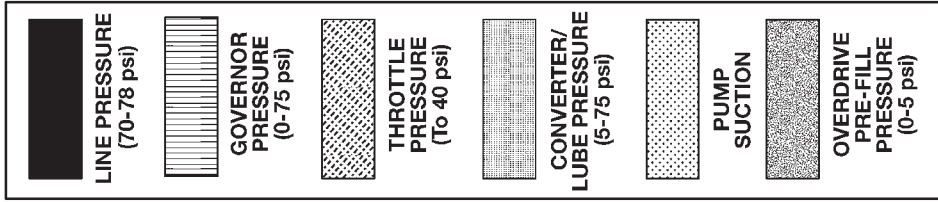
80abfd80



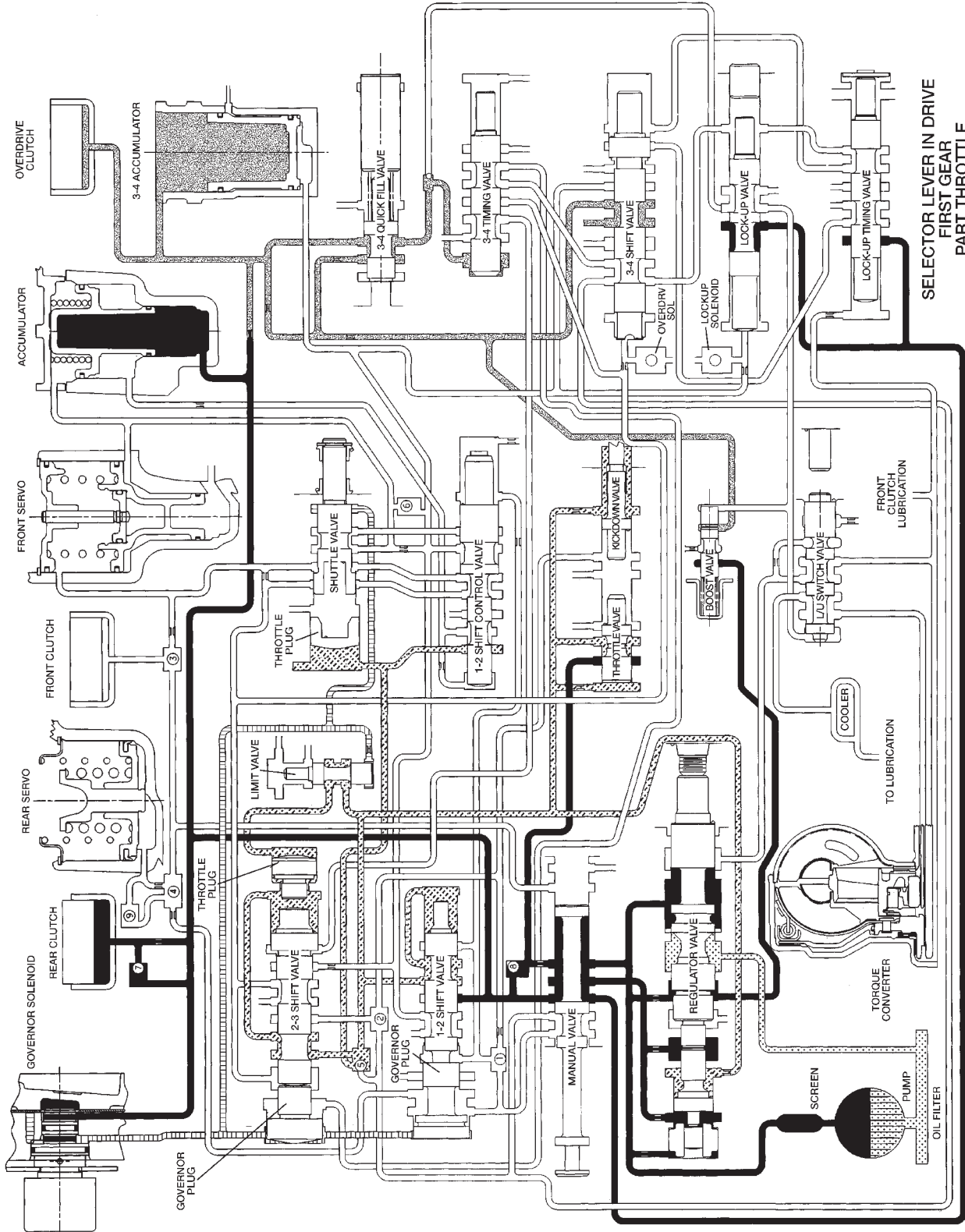
SELECTOR LEVER IN REVERSE

HYDRAULIC FLOW IN REVERSE

SCHEMATICS AND DIAGRAMS (Continued)

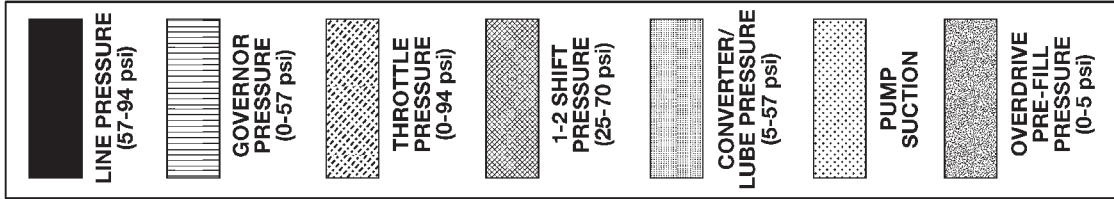


80abrd83

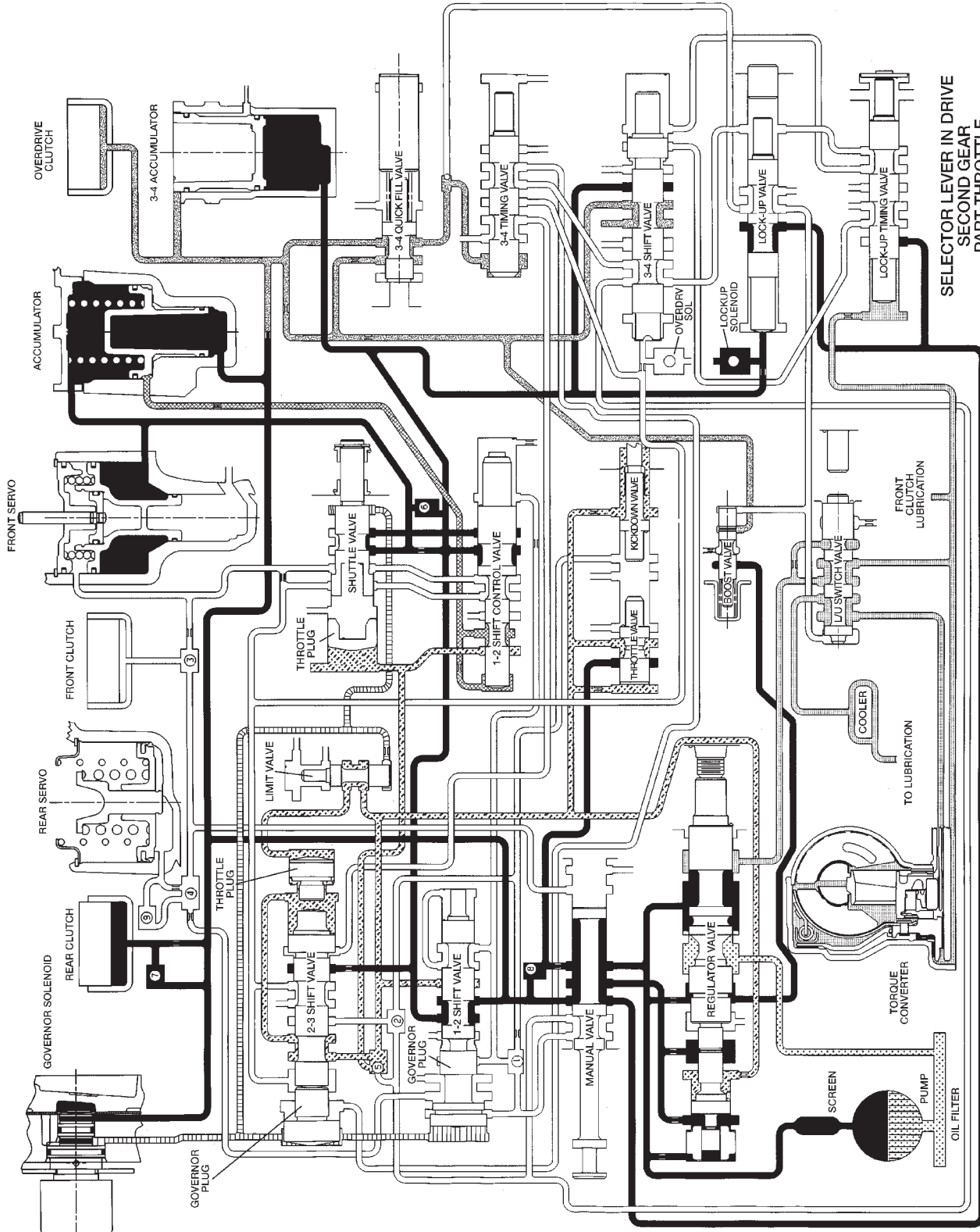


HYDRAULIC FLOW IN DRIVE FIRST GEAR

SCHEMATICS AND DIAGRAMS (Continued)

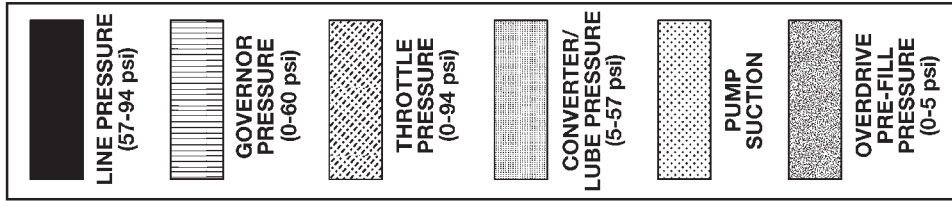


80abrf84

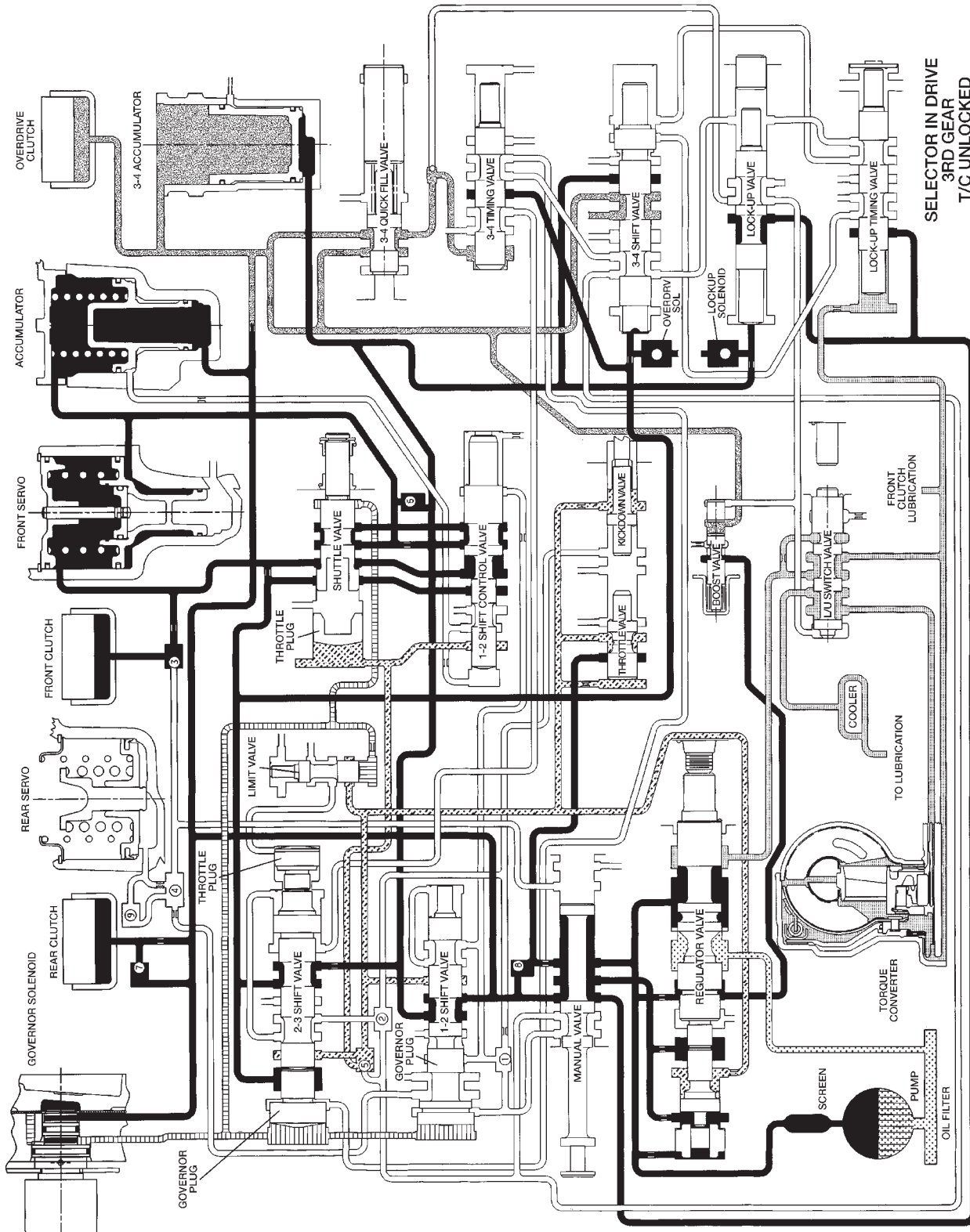


HYDRAULIC FLOW IN DRIVE SECOND GEAR

SCHEMATICS AND DIAGRAMS (Continued)

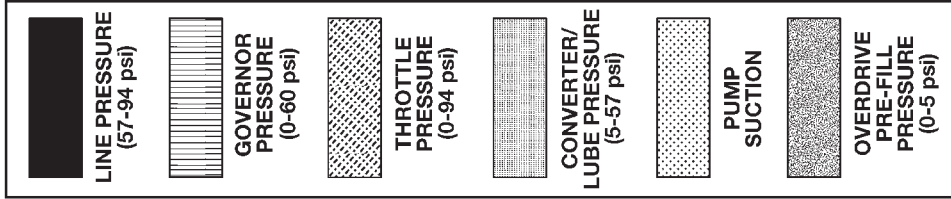


80abfd85

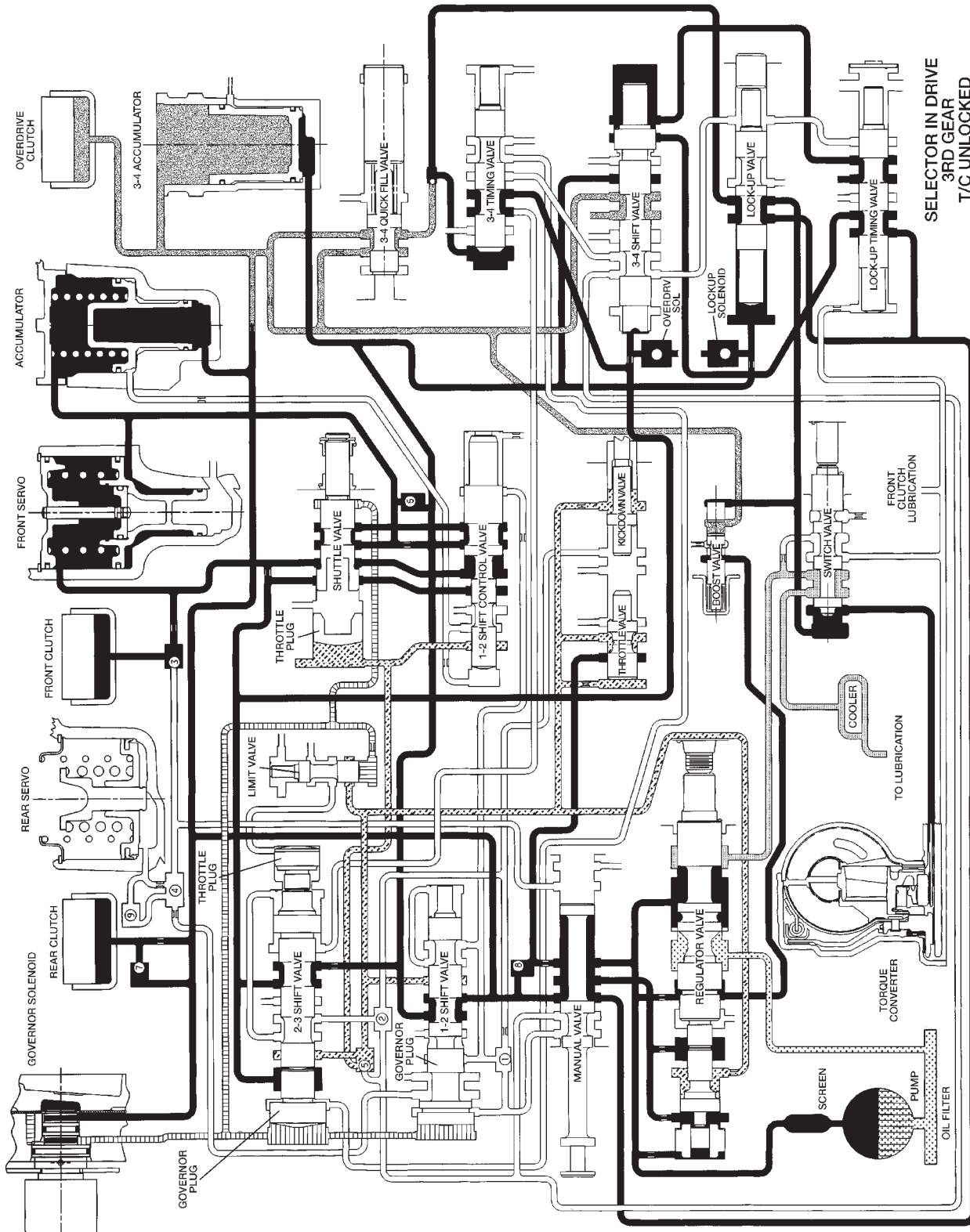


HYDRAULIC FLOW IN DRIVE THIRD GEAR (CONVERTER CLUTCH NOT APPLIED)

SCHEMATICS AND DIAGRAMS (Continued)



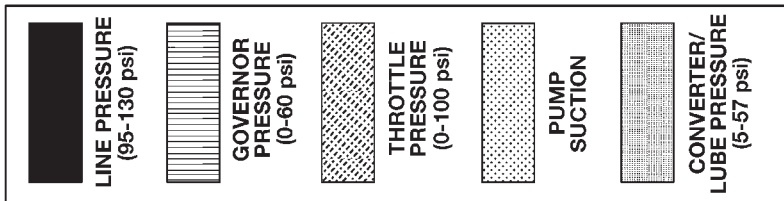
80abrid8c



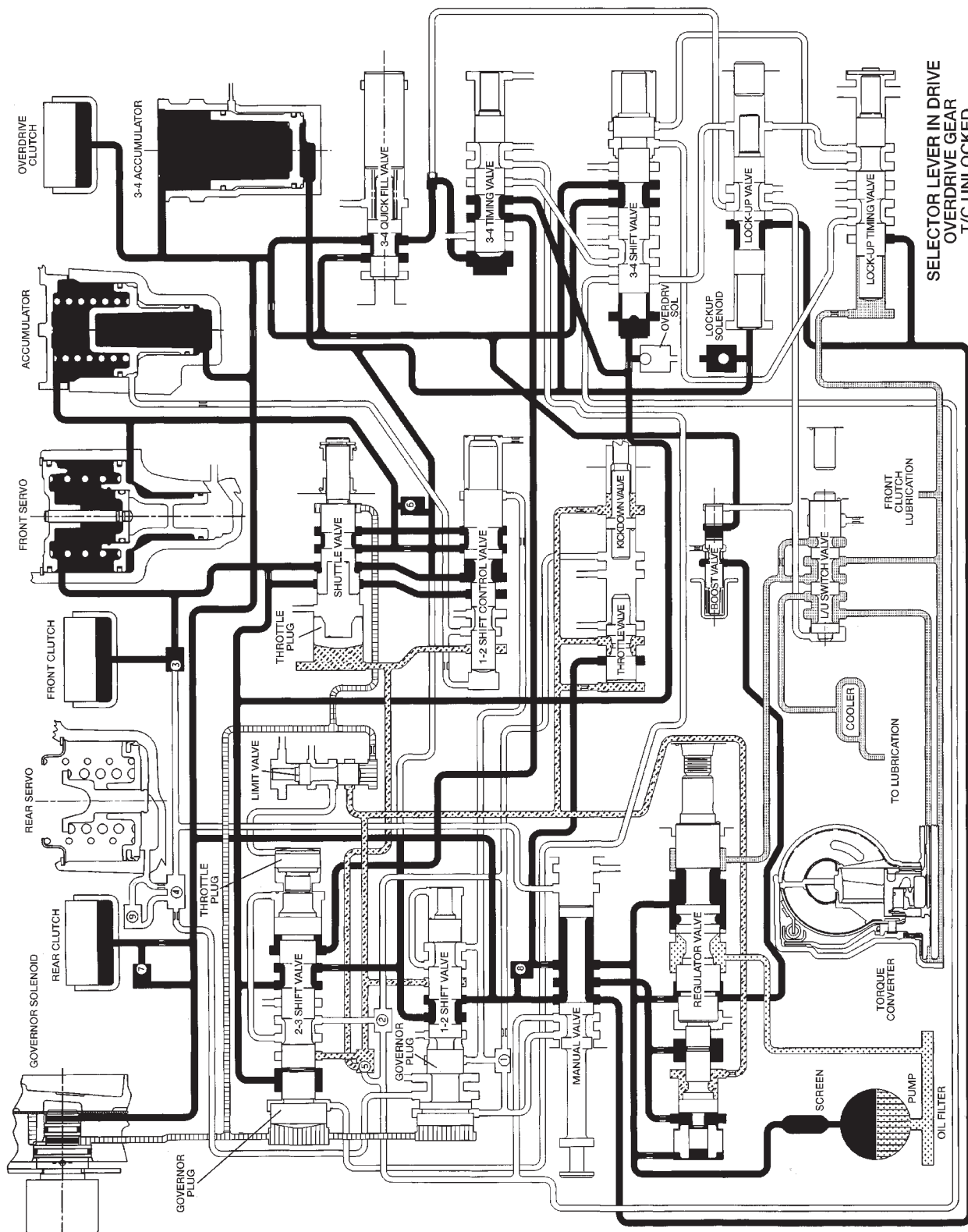
HYDRAULIC FLOW IN DRIVE THIRD GEAR (CONVERTER CLUTCH APPLIED)

SELECTOR IN DRIVE
3RD GEAR
T/C UNLOCKED

SCHEMATICS AND DIAGRAMS (Continued)



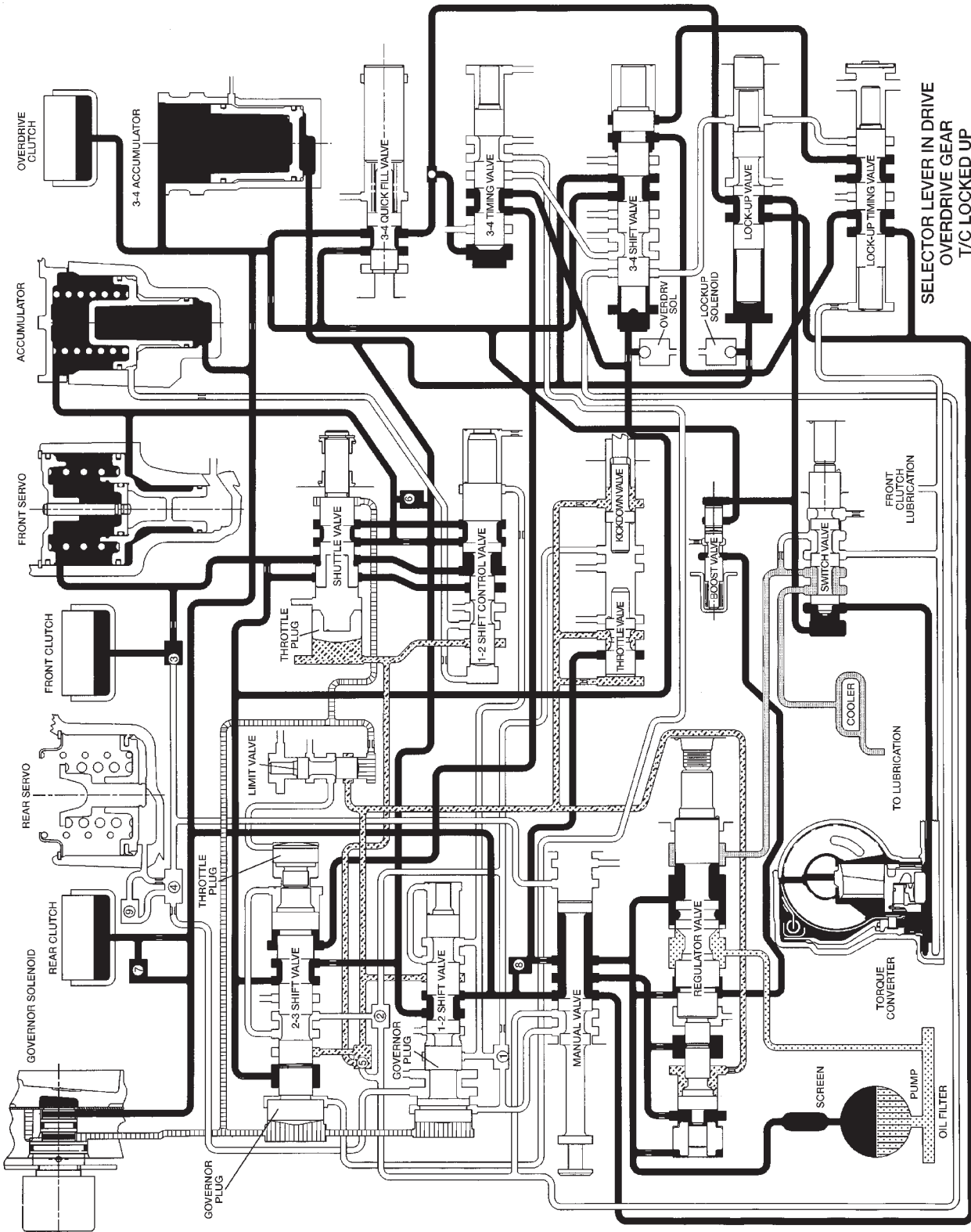
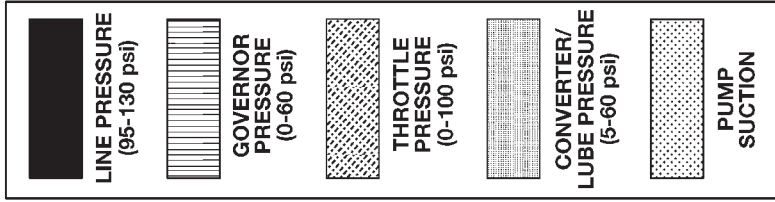
80abfd68



SELECTOR LEVER IN DRIVE
OVERDRIVE GEAR
T/C UNLOCKED

HYDRAULIC FLOW IN DRIVE FOURTH GEAR (CONVERTER CLUTCH NOT APPLIED)

SCHEMATICS AND DIAGRAMS (Continued)

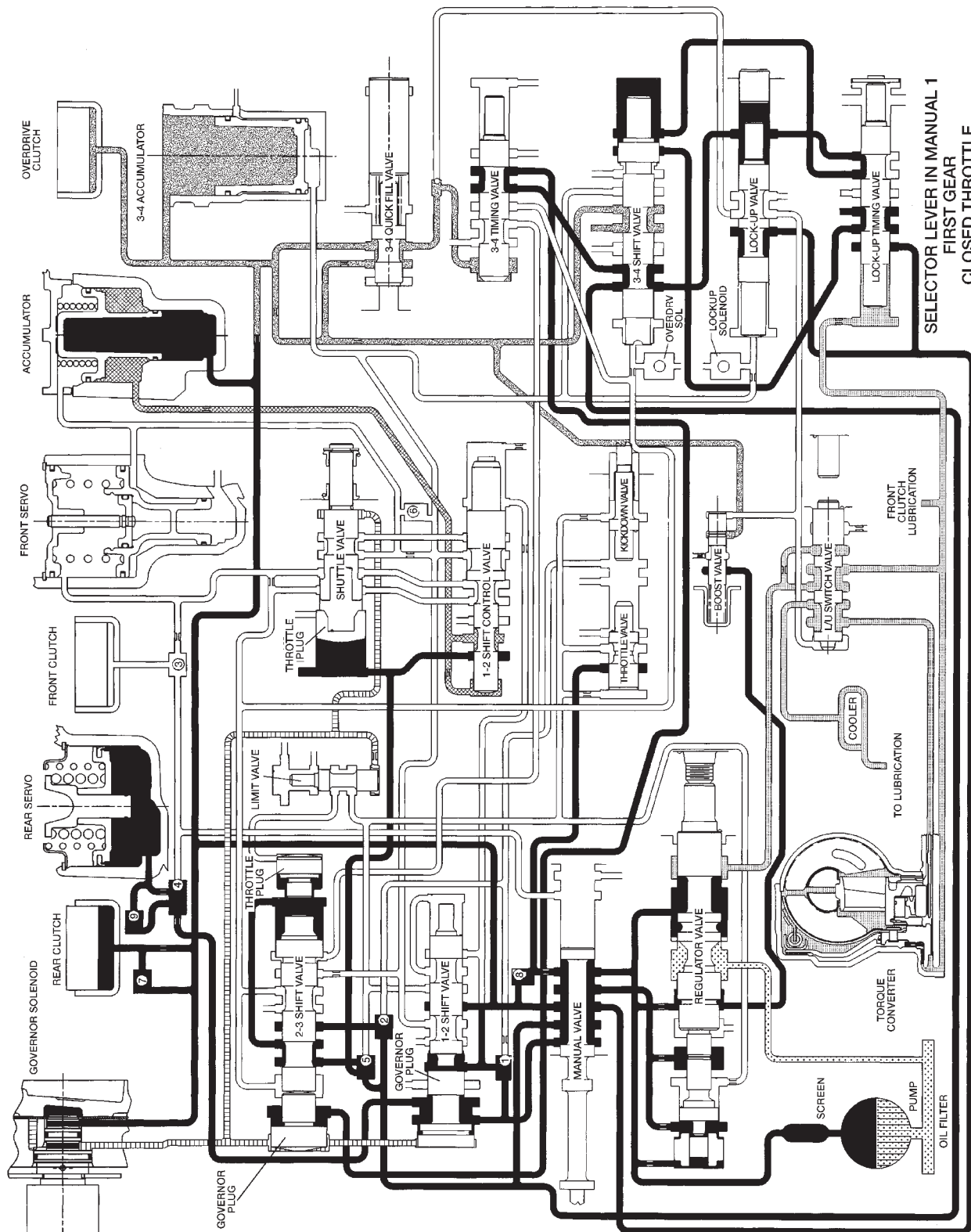
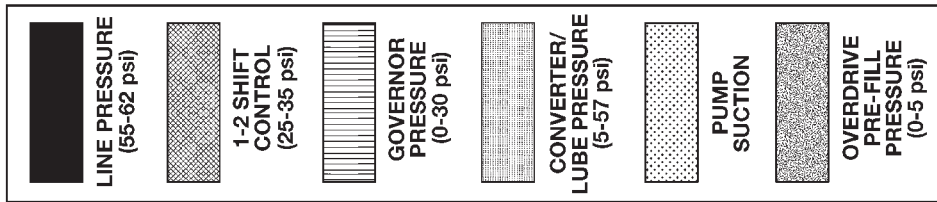


SELECTOR LEVER IN DRIVE
OVERDRIVE GEAR
T/C LOCKED UP

HYDRAULIC FLOW IN DRIVE FOURTH GEAR (CONVERTER CLUTCH APPLIED)

80abfd87

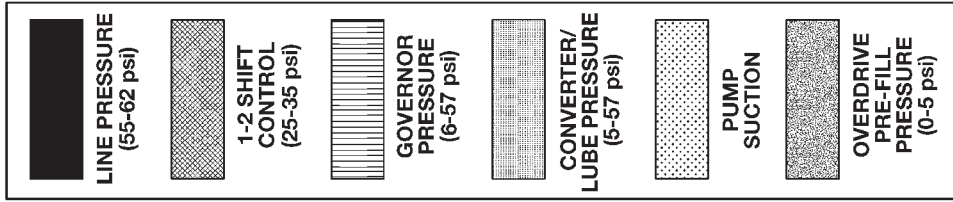
SCHEMATICS AND DIAGRAMS (Continued)



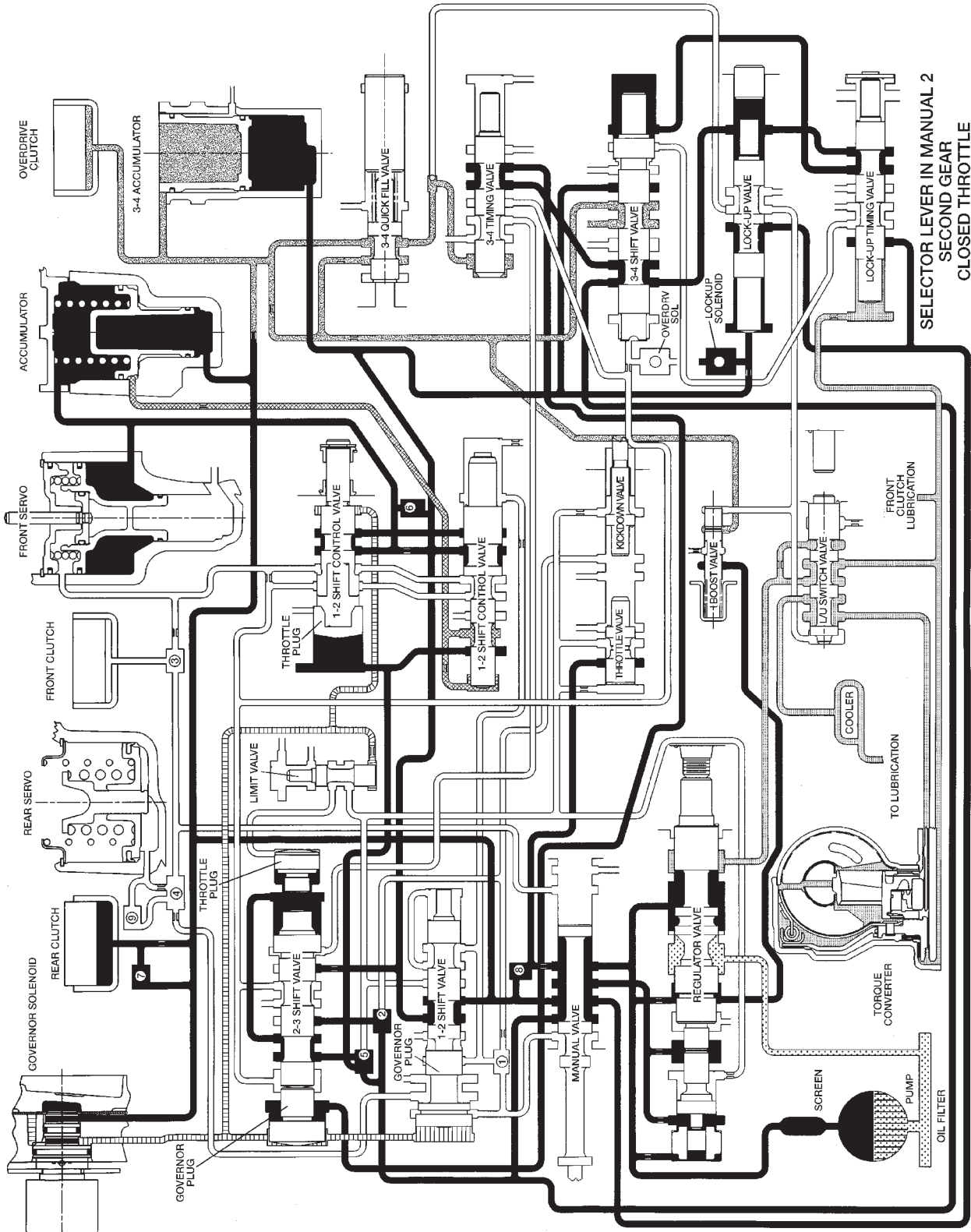
HYDRAULIC FLOW IN MANUAL LOW (1)

80abfd88

SCHEMATICS AND DIAGRAMS (Continued)

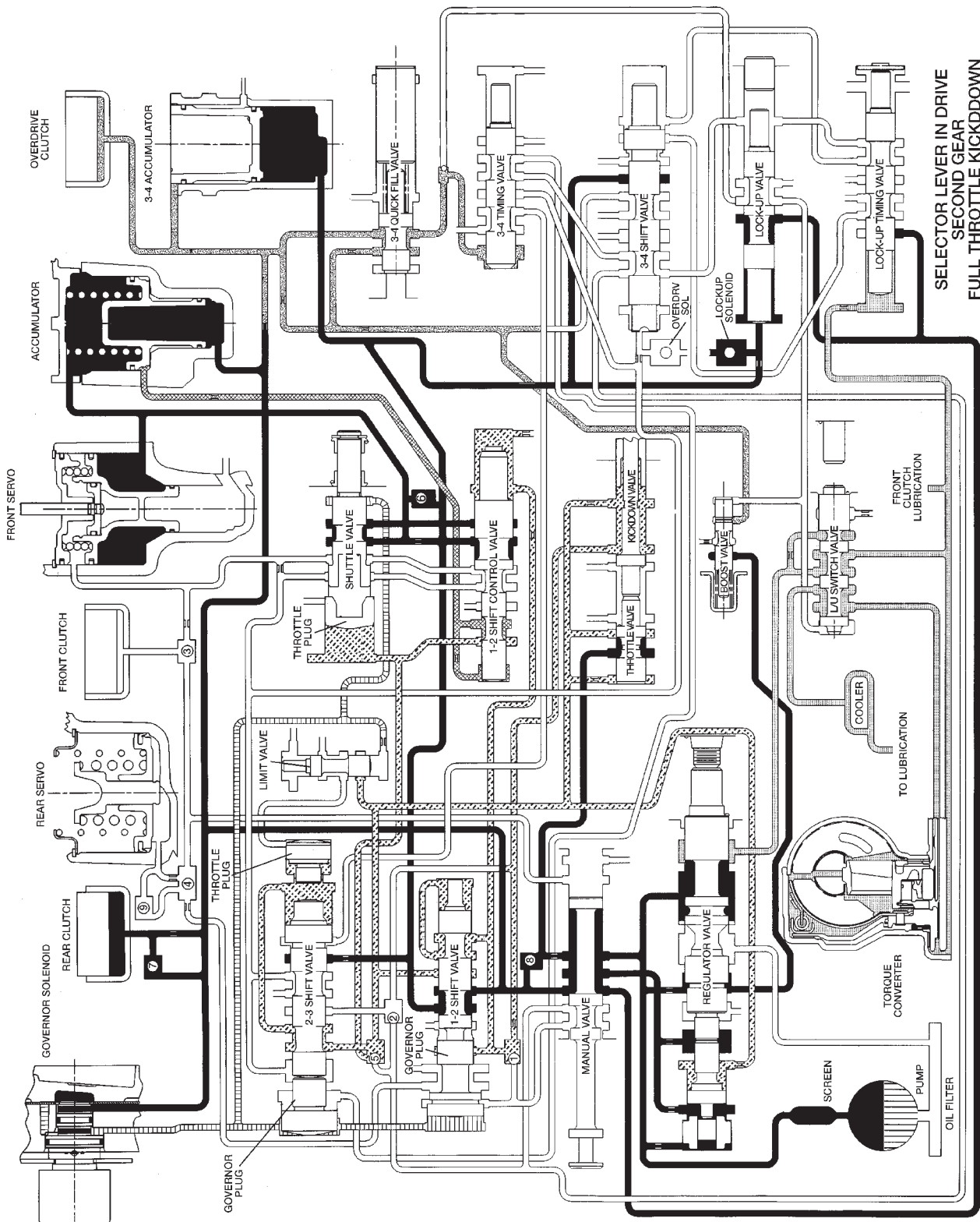
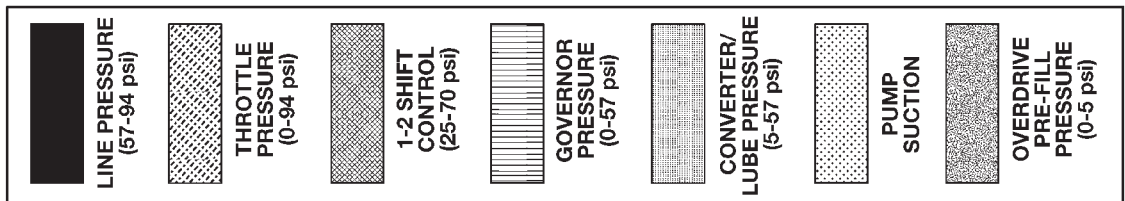


80abfd89



HYDRAULIC FLOW IN MANUAL SECOND (2)

SCHEMATICS AND DIAGRAMS (Continued)



SELECTOR LEVER IN DRIVE
SECOND GEAR
FULL THROTTLE KICKDOWN

HYDRAULIC FLOW DURING FULL THROTTLE 3-2 DOWNSHIFT (PASSING GEAR)

80abfd8a

SPECIFICATIONS**TRANSMISSION****GENERAL**

Component	Metric	Inch
Planetary end play	0.127-1.22 mm	0.005-0.048 in.
Input shaft end play	0.56-2.31 mm	0.022-0.091 in.
Clutch pack clearance/ Front.	1.70- 3.40mm	0.067-0.134 in.
Clutch pack clearance/ Rear.	0.81-1.40 mm	0.022-0.037 in.
Front Clutch	42RE-4 discs	
	44RE-5 discs	
Rear Clutch	42RE and 44RE-4 discs	
Overdrive clutch disc usage	42RE-3 discs	
	44RE-4 discs	
Direct clutch disc usage	42RE-6 discs	
	44RE-8 discs	
42RE Band adjustment from 72 in. lbs.		
Front band	Back off 3-5/8 turns	
Rear band	Back off 4 turns	
44RE Band adjustment from 72 in. lbs.		
Front band	Back off 2-1/4 turns	
Rear band	Back off 4 turns	
Recommended fluid	Mopar® ATF Plus 3, type 7176	

GEAR RATIOS

- 1ST GEAR-2.74
- 2ND GEAR-1.54
- 3RD GEAR-1.00
- 4TH GEAR-0.69
- REV.GEAR-2.21

TORQUE

DESCRIPTION	TORQUE
Fitting, cooler line at trans	18 N·m (13 ft. lbs.)
Bolt, torque convertor	31 N·m (23 ft. lbs.)
Bolt/nut, crossmember	68 N·m (50 ft. lbs.)
Bolt, driveplate to crankshaft	75 N·m (55 ft. lbs.)
Plug, front band reaction	17 N·m (13 ft. lbs.)
Locknut, front band adj.	34 N·m (25 ft. lbs.)
Switch, park/neutral	34 N·m (25 ft. lbs.)
Bolt, fluid pan	17 N·m (13 ft. lbs.)
Screws, fluid filter	4 N·m (35 in. lbs.)
Bolt, oil pump	20 N·m (15 ft. lbs.)
Bolt, overrunning clutch cam	17 N·m (13 ft. lbs.)
Bolt, O/D to trans.	34 N·m (25 ft. lbs.)
Bolt, O/D piston retainer	17 N·m (13 ft. lbs.)
Plug, pressure test port	14 N·m (10 ft. lbs.)
Bolt, reaction shaft support	20 N·m (15 ft. lbs.)
Locknut, rear band	41 N·m (30 ft. lbs.)
Bolt, speedometer adapter	11 N·m (8 ft. lbs.)
Bolt, valve body to case	12 N·m (100 in. lbs.)
Sensor, trans speed	27 N·m (20 ft. lbs.)
Screw, solenoid wiring connector	4 N·m (35 in. lbs.)
Screw, solenoid to transfer plate	4 N·m (35 in. lbs.)

SPECIFICATIONS (Continued)

THRUST WASHER/SPACER/SNAP RING DIMENSIONS

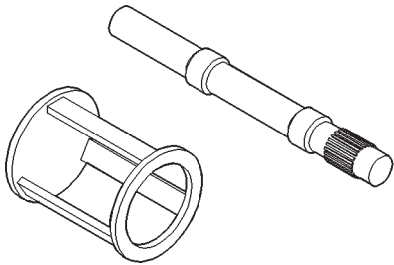
Component	Metric	Inch
Front clutch thrust washer (reaction shaft support hub)	1.55 mm	0.061 in.
Rear clutch thrust washer (clutch retainer)	1.55 mm	0.061 in.
Intermediate shaft thrust plate (shaft hub pilot)	1.5-1.6 mm	0.060-0.063 in.
Output shaft thrust washer (rear clutch hub)	Select fit to set end play	
Rear clutch pack snap ring	1.5 mm	0.060 in.
	1.95 mm	0.076 in.
	2.45 mm	0.098 in.
Planetary geartrain snap ring (at front of output shaft)	Select fit (three thicknesses available)	
Overdrive piston thrust plate	Thrust plate and spacer are select fit. Refer to size charts and selection procedures in Overdrive Unit D&A procedures	
Intermediate shaft spacer		

PRESSURE TEST

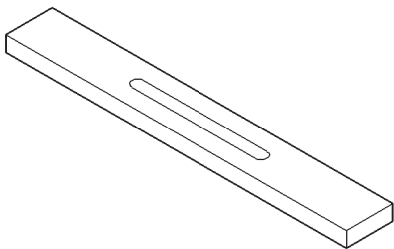
Overdrive clutch	Fourth gear only	Pressure should be 469-496 kPa (68-72 psi) with closed throttle and increase to 620-896 kPa (90-130 psi) at 1/2 to 3/4 throttle.
Line pressure (at accumulator)	Closed throttle	372-414 kPa (54-60 psi).
Front servo	Third gear only	No more than 21 kPa (3 psi) lower than line pressure.
Rear servo	1 range R range	No more than 21 kPa (3 psi) lower than line pressure. 1103 kPa (160 psi) at idle, builds to 1862 kPa (270 psi) at 1600 rpm.
Governor	D range closed throttle	Pressure should respond smoothly to changes in mph and return to 0-7 kPa (0-1.5 psi) when stopped with transmission in D, 1, 2. Pressure above 7 kPa (1.5 psi) at stand still will prevent transmission from downshifting.

SPECIAL TOOLS

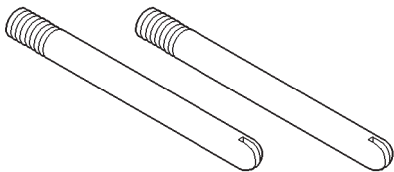
RE TRANSMISSIONS



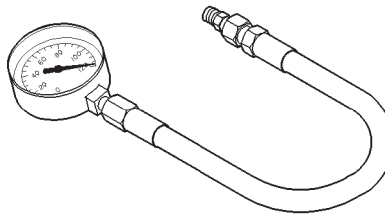
Spring Compressor and Alignment Shaft—6227



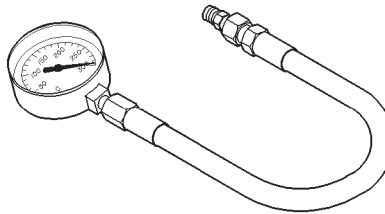
Gauge Bar—6311



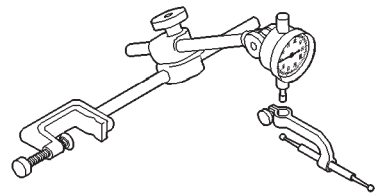
Extension Housing Pilot—C-3288-B



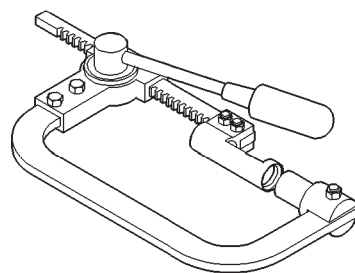
Pressure Gauge—C-3292



Pressure Gauge—C-3293SP

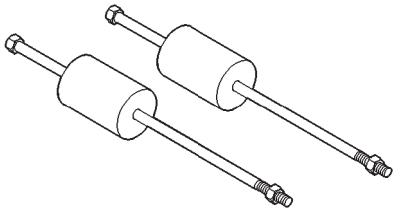


Dial Indicator—C-3339

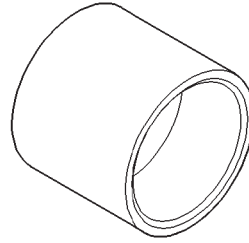


Spring Compressor—C-3422-B

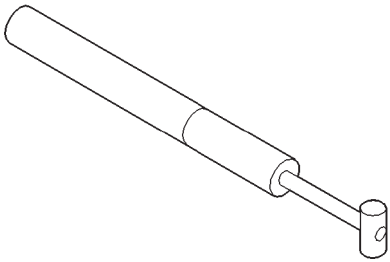
SPECIAL TOOLS (Continued)



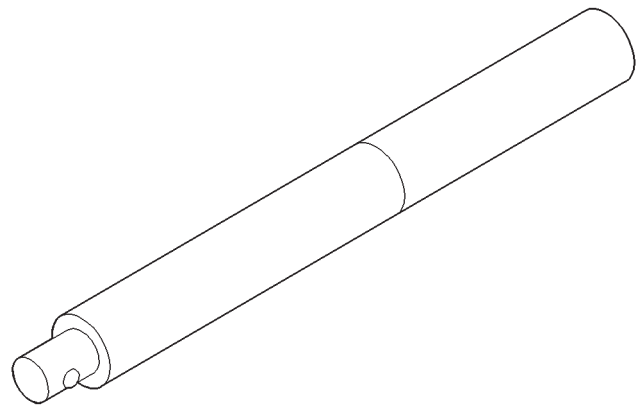
Puller, Slide Hammer—C-3752



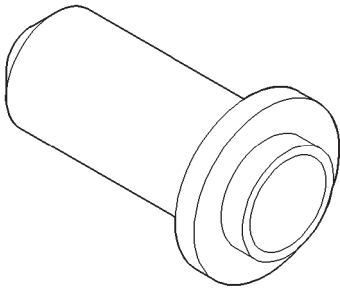
Installer—C-3995-A



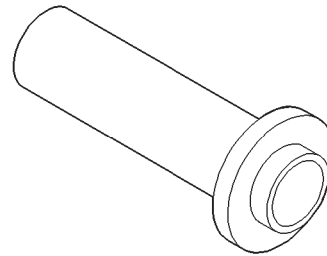
Gauge, Throttle Setting—C-3763



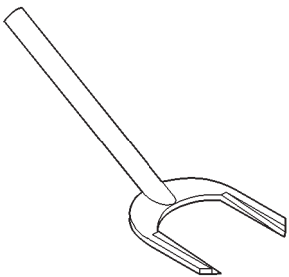
Universal Handle—C-4171



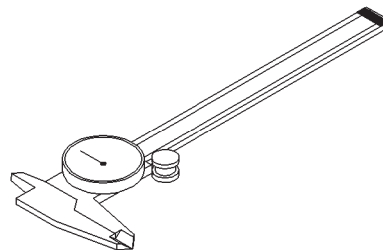
Seal Installer—C-3860-A



Seal Installer—C-4193-A

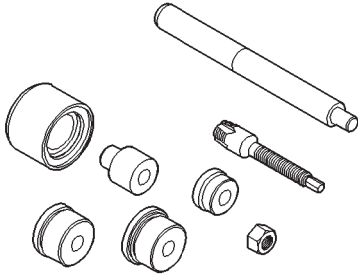


Seal Remover—C-3985-B

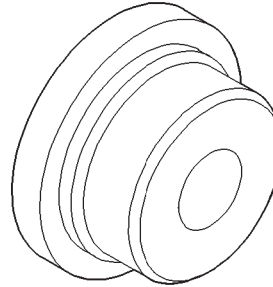


Dial Caliper—C-4962

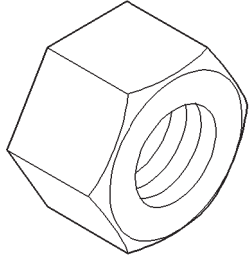
SPECIAL TOOLS (Continued)



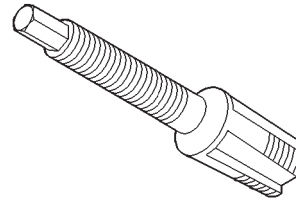
Bushing Remover/Installer Set—C-3887-J



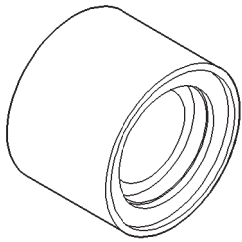
Installer, Bushing—SP-5117



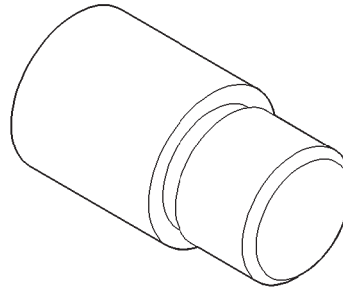
Nut, Bushing Remover—SP-1191, From kit C-3887-J



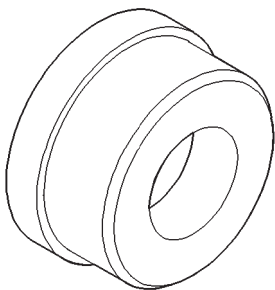
Remover, Bushing—SP-5324



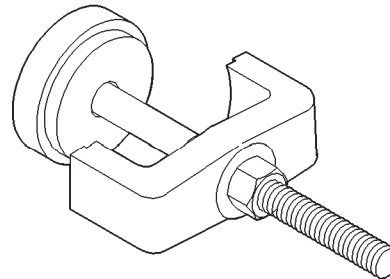
Cup, Bushing Remover—SP-3633, From kit C-3887-J



Installer, Bushing—SP-5325

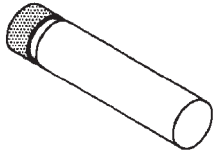


Remover, Bushing—SP-3551

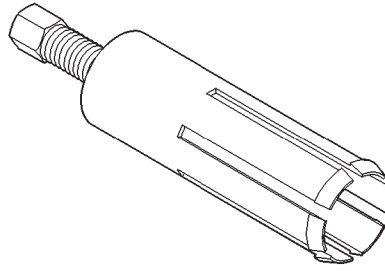


Compressor, Spring—C-3575-A

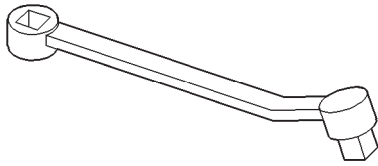
SPECIAL TOOLS (Continued)



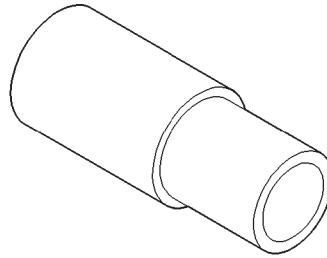
Gauge—6312



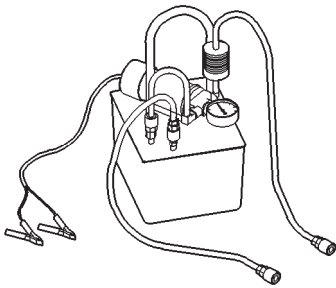
Remover—6957



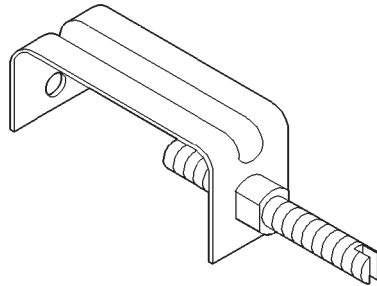
Adapter—C-3705



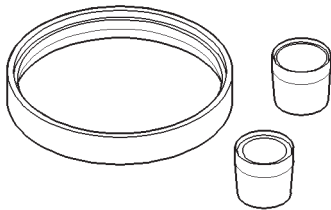
Installer—6951



Flusher—6906



Retainer—6583



Installer—8114

46RE AUTOMATIC TRANSMISSION

INDEX

	page		page
GENERAL INFORMATION		TRANSMISSION FILL PROCEDURE	147
46RE TRANSMISSION	119	REMOVAL AND INSTALLATION	
CAUSES OF BURNT FLUID	121	BRAKE TRANSMISSION SHIFT INTERLOCK . .	153
EFFECTS OF INCORRECT FLUID LEVEL	121	GEARSHIFT CABLE	153
ELECTRONIC LOCK-UP TORQUE		GOVERNOR SOLENOID AND PRESSURE	
CONVERTER	121	SENSOR	154
FLUID CONTAMINATION	121	OUTPUT SHAFT FRONT BEARING	159
GEARSHIFT MECHANISM	122	OUTPUT SHAFT REAR BEARING	159
RECOMMENDED FLUID	121	OVERDRIVE HOUSING BUSHING	158
TRANSMISSION GEAR RATIOS	122	OVERDRIVE UNIT	157
TRANSMISSION IDENTIFICATION	121	PARK/NEUTRAL POSITION SWITCH	152
DESCRIPTION AND OPERATION		SPEEDOMETER ADAPTER	151
3-4 SHIFT SEQUENCE	124	TORQUE CONVERTER	150
BRAKE TRANSMISSION SHIFT INTERLOCK		TRANSMISSION	148
MECHANISM	125	VALVE BODY	154
CONVERTER CLUTCH ENGAGEMENT	125	YOKE SEAL REPLACEMENT	151
CONVERTER DRAINBACK VALVE	125	DISASSEMBLY AND ASSEMBLY	
ELECTRONIC GOVERNOR	122	FRONT CLUTCH	192
GOVERNOR PRESSURE CURVES	123	FRONT SERVO PISTON	190
HYDRAULIC CONTROL SYSTEM	124	OIL PUMP AND REACTION SHAFT SUPPORT .	190
OVERDRIVE OFF SWITCH	124	OVERDRIVE UNIT	200
QUICK FILL VALVE	125	OVERRUNNING CLUTCH CAM/OVERDRIVE	
SHIFT VALVE OPERATION	124	PISTON RETAINER	187
DIAGNOSIS AND TESTING		PLANETARY GEARTRAIN/OUTPUT SHAFT . . .	196
AIR TESTING TRANSMISSION CLUTCH AND		REAR CLUTCH	193
BAND OPERATION	131	REAR SERVO PISTON	190
ANALYZING ROAD TEST	127	TRANSMISSION	175
AUTOMATIC TRANSMISSION DIAGNOSIS . . .	125	VALVE BODY	160
BRAKE TRANSMISSION SHIFT INTERLOCK . .	127	CLEANING AND INSPECTION	
CONVERTER HOUSING FLUID LEAK		ACCUMULATOR	216
DIAGNOSIS	132	FRONT CLUTCH	217
CONVERTER STALL TEST	131	FRONT SERVO	216
DIAGNOSIS TABLES AND CHARTS—RE		OIL PUMP AND REACTION SHAFT SUPPORT .	217
TRANSMISSION	133	OVERDRIVE UNIT	218
GEARSHIFT CABLE	127	OVERRUNNING CLUTCH/LOW-REVERSE	
HYDRAULIC PRESSURE TEST	128	DRUM/OVERDRIVE PISTON RETAINER	216
OVERDRIVE ELECTRICAL CONTROLS	127	PLANETARY GEARTRAIN/OUTPUT SHAFT . . .	218
PARK/NEUTRAL POSITION SWITCH	126	REAR CLUTCH	218
PRELIMINARY DIAGNOSIS	125	REAR SERVO	217
ROAD TESTING	127	TRANSMISSION	216
STALL TEST ANALYSIS	131	VALVE BODY	214
THROTTLE VALVE CABLE	127	ADJUSTMENTS	
SERVICE PROCEDURES		BRAKE TRANSMISSION SHIFT INTERLOCK . .	219
ALUMINUM THREAD REPAIR	148	FRONT BAND ADJUSTMENT	221
CONVERTER DRAINBACK CHECK VALVE		GEARSHIFT CABLE	221
SERVICE	147	REAR BAND ADJUSTMENT	222
FLUID AND FILTER REPLACEMENT	146	TRANSMISSION THROTTLE VALVE CABLE	
FLUID LEVEL CHECK	146	ADJUSTMENT	220
FLUSHING COOLERS AND TUBES	148	VALVE BODY	222
OIL PUMP VOLUME CHECK	147		

SCHEMATICS AND DIAGRAMS

HYDRAULIC SCHEMATICS 223

SPECIFICATIONS

RE TRANSMISSION 235

SPECIAL TOOLS

RE TRANSMISSION 236

GENERAL INFORMATION

46RE TRANSMISSION

The 46RE is a four speed fully automatic transmission with an electronic governor (Fig. 1). First through third gear ranges are provided by the clutches, bands, overrunning clutch, and planetary gear sets in the transmission. Fourth gear range is provided by the overdrive unit that contains an overdrive clutch, direct clutch, planetary gear set, and overrunning clutch. The overdrive clutch is applied in fourth gear only. The direct clutch is applied in all ranges except fourth gear. The 46RE is equipped with a lock-up clutch in the torque converter. The torque converter clutch is controlled by the Power-

train Control Module (PCM). The torque converter clutch is hydraulically applied and is released when fluid is vented from the hydraulic circuit by the torque converter control (TCC) solenoid on the valve body. The torque converter clutch engages in fourth gear, and in third gear when the O/D switch is OFF. Engagement occurs when the vehicle is cruising at a steady speed after the vehicle has warmed up. The torque converter clutch disengages when the vehicle begins to go uphill or the accelerator is applied. The torque converter clutch feature increases fuel economy and reduces the transmission fluid temperature. The 46RE transmission is cooled by an integral fluid cooler inside the radiator.

GENERAL INFORMATION (Continued)

801834a2

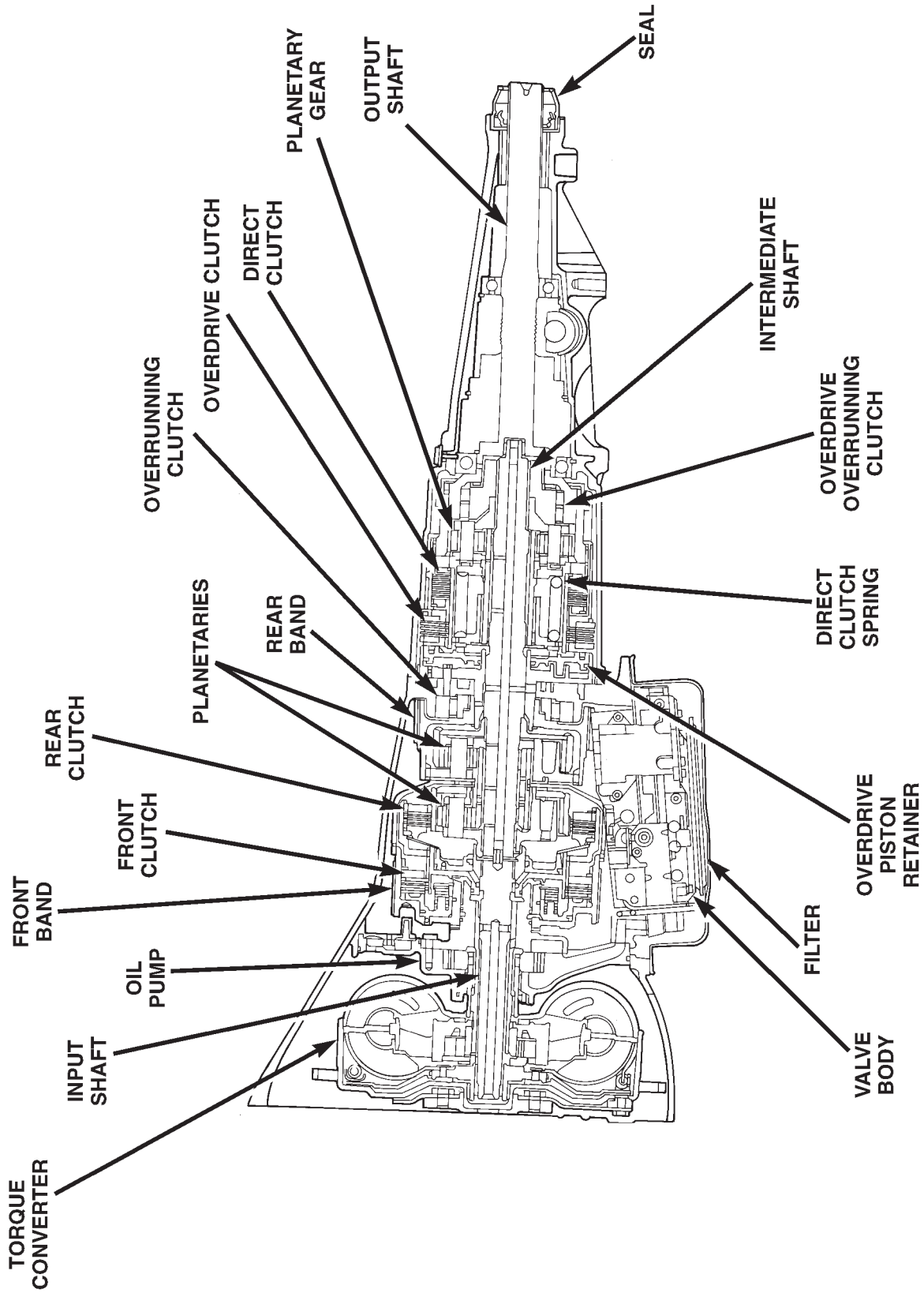
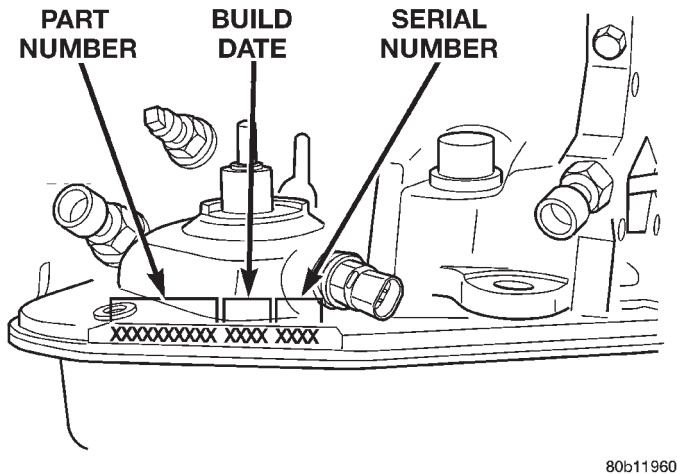


Fig. 1 46RE Transmission

GENERAL INFORMATION (Continued)

TRANSMISSION IDENTIFICATION

Transmission identification numbers are stamped on the left side of the case just above the oil pan gasket surface (Fig. 2). Refer to this information when ordering replacement parts.



80b11960

Fig. 2 Transmission Part And Serial Number Location

RECOMMENDED FLUID

Mopar® ATF Plus 3, Type 7176 automatic transmission fluid is the recommended fluid for Chrysler automatic transmissions.

Dexron II fluid IS NOT recommended. Clutch chatter can result from the use of improper fluid.

EFFECTS OF INCORRECT FLUID LEVEL

A low fluid level allows the pump to take in air along with the fluid. Air in the fluid will cause fluid pressures to be low and develop slower than normal. If the transmission is overfilled, the gears churn the fluid into foam. This aerates the fluid and causing the same conditions occurring with a low level. In either case, air bubbles cause fluid overheating, oxidation and varnish buildup which interferes with valve, clutch and servo operation. Foaming also causes fluid expansion which can result in fluid overflow from the transmission vent or fill tube. Fluid overflow can easily be mistaken for a leak if inspection is not careful.

CAUSES OF BURNT FLUID

Burnt, discolored fluid is a result of overheating which has two primary causes.

(1) A result of restricted fluid flow through the main and/or auxiliary cooler. This condition is usually the result of a faulty or improperly installed drainback valve, a damaged main cooler, or severe restrictions in the coolers and lines caused by debris or kinked lines.

(2) Heavy duty operation with a vehicle not properly equipped for this type of operation. Trailer towing or similar high load operation will overheat the transmission fluid if the vehicle is improperly equipped. Such vehicles should have an auxiliary transmission fluid cooler, a heavy duty cooling system, and the engine/axle ratio combination needed to handle heavy loads.

FLUID CONTAMINATION

Transmission fluid contamination is generally a result of:

- adding incorrect fluid
- failure to clean dipstick and fill tube when checking level
- engine coolant entering the fluid
- internal failure that generates debris
- overheat that generates sludge (fluid breakdown)
- failure to reverse flush cooler and lines after repair
- failure to replace contaminated converter after repair

The use of non recommended fluids can result in transmission failure. The usual results are erratic shifts, slippage, abnormal wear and eventual failure due to fluid breakdown and sludge formation. Avoid this condition by using recommended fluids only.

The dipstick cap and fill tube should be wiped clean before checking fluid level. Dirt, grease and other foreign material on the cap and tube could fall into the tube if not removed beforehand. Take the time to wipe the cap and tube clean before withdrawing the dipstick.

Engine coolant in the transmission fluid is generally caused by a cooler malfunction. The only remedy is to replace the radiator as the cooler in the radiator is not a serviceable part. If coolant has circulated through the transmission for some time, an overhaul may also be necessary; especially if shift problems had developed.

The transmission cooler and lines should be reverse flushed whenever a malfunction generates sludge and/or debris. The torque converter should also be replaced at the same time.

Failure to flush the cooler and lines will result in recontamination. Flushing applies to auxiliary coolers as well. The torque converter should also be replaced whenever a failure generates sludge and debris. This is necessary because normal converter flushing procedures will not remove all contaminants.

ELECTRONIC LOCK-UP TORQUE CONVERTER

The torque converter is a hydraulic device that couples the engine crankshaft to the transmission.

GENERAL INFORMATION (Continued)

The torque converter consists of an outer shell with an internal turbine, a stator, an overrunning clutch, an impeller, and an electronically applied converter clutch. Torque multiplication is created when the stator directs the hydraulic flow from the turbine to rotate the impeller in the direction the engine crankshaft is turning. The turbine transfers power to the planetary gear sets in the transmission. The transfer of power into the impeller assists torque multiplication. At low vehicle-speed, the overrunning clutch holds the stator stationary (during torque multiplication) and allows the stator to freewheel at high vehicle speed. The converter clutch engagement reduces engine speed. Clutch engagement also provides reduced transmission fluid temperatures. The torque converter hub drives the transmission oil (fluid) pump.

The torque converter is a sealed, welded unit that is not repairable and is serviced as an assembly.

CAUTION: The torque converter must be replaced if a transmission failure results in large amounts of metal or fiber contamination in the fluid.

TRANSMISSION GEAR RATIOS

46RE gear ratios are:

- 2.45:1 (first gear)
- 1.45:1 (second gear)
- 1.00:1 (third gear)
- 0.69:1 (fourth gear)
- 2.21 (reverse)

GEARSHIFT MECHANISM

The shift mechanism is cable operated and provides six shift positions. The shift positions are:

- Park (P)
- Reverse (R)
- Neutral (N)
- Drive (D)
- Manual Second (2)
- Manual Low (1)

Manual low (1) range provides first gear only. Overrun braking is also provided in this range. Manual second (2) range provides first and second gear only. Drive range provides first, second, third, and overdrive fourth gear ranges. The shift into overdrive fourth gear range occurs only after the transmission has completed the shift into (D) third gear range. No further movement of the shift mechanism is required to complete the 3-4 shift.

DESCRIPTION AND OPERATION

ELECTRONIC GOVERNOR

Governor pressure is controlled electronically. Components used for governor pressure control include:

- Governor body
- Valve body transfer plate
- Governor pressure solenoid valve
- Governor pressure sensor
- Fluid temperature thermistor
- Throttle position sensor (TPS)
- Transmission speed sensor
- Powertrain control module (PCM)

GOVERNOR PRESSURE SOLENOID VALVE

The solenoid valve is a duty-cycle solenoid which regulates the governor pressure needed for upshifts and downshifts. It is an electro-hydraulic device located in the governor body on the valve body transfer plate (Fig. 3).

The inlet side of the solenoid valve is exposed to normal transmission line pressure. The outlet side of the valve leads to the valve body governor circuit.

The solenoid valve regulates line pressure to produce governor pressure. The average current supplied to the solenoid controls governor pressure. One amp current produces zero kPa/psi governor pressure. Zero amps sets the maximum governor pressure.

The powertrain control module (PCM) turns on the trans control relay which supplies electrical power to the solenoid valve. Operating voltage is 12 volts (DC). The PCM controls the ground side of the solenoid using the governor pressure solenoid control circuit.

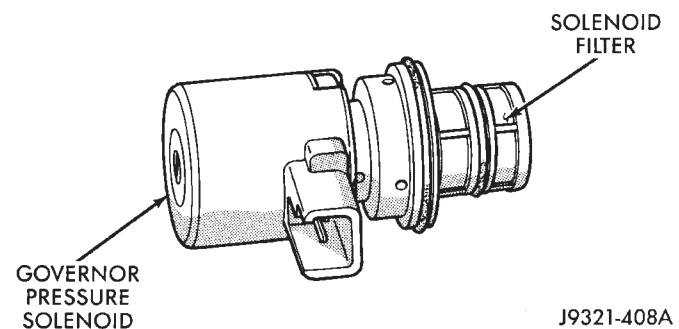


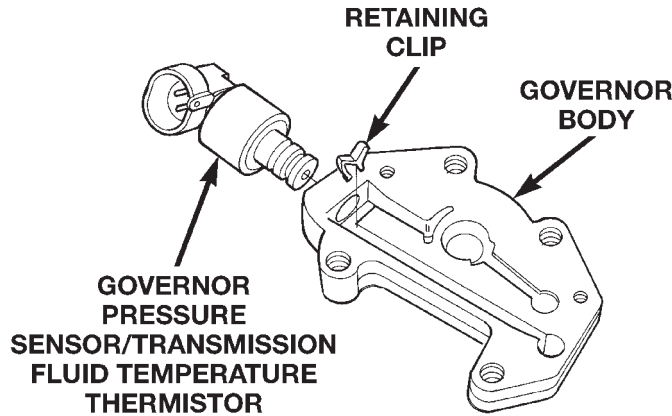
Fig. 3 Governor Pressure Solenoid Valve

GOVERNOR PRESSURE SENSOR

The governor pressure sensor measures output pressure of the governor pressure solenoid valve (Fig. 4).

The sensor output signal provides the necessary feedback to the PCM. This feedback is needed to adequately control governor pressure.

DESCRIPTION AND OPERATION (Continued)



80a0c4fa

Fig. 4 Governor Pressure Sensor

GOVERNOR BODY AND TRANSFER PLATE

The transfer plate is designed to supply transmission line pressure to the governor pressure solenoid valve and to return governor pressure.

The governor pressure solenoid valve is mounted in the governor body. The body is bolted to the lower side of the transfer plate (Fig. 4). The transfer plate channels line pressure to the solenoid valve through the governor body. It also channels governor pressure from the solenoid valve to the governor circuit. It is the solenoid valve that develops the necessary governor pressure.

TRANSMISSION FLUID TEMPERATURE THERMISTOR

Transmission fluid temperature readings are supplied to the transmission control module by the thermistor. The temperature readings are used to control engagement of the fourth gear overdrive clutch, the converter clutch, and governor pressure. Normal resistance value for the thermistor at room temperature is approximately 1000 ohms.

The PCM prevents engagement of the converter clutch and overdrive clutch, when fluid temperature is below approximately 10°C (50°F).

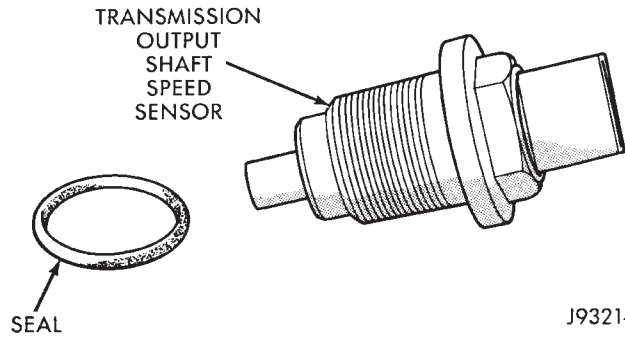
If fluid temperature exceeds 126°C (260°F), the PCM causes a 4-3 downshift and engage the converter clutch. Engagement is according to the third gear converter clutch engagement schedule.

The overdrive OFF lamp in the instrument panel illuminates when the shift back to third occurs. The transmission will not allow fourth gear operation until fluid temperature decreases to approximately 110°C (230°F).

The thermistor is part of the governor pressure sensor assembly and is immersed in transmission fluid at all times.

TRANSMISSION SPEED SENSOR

The speed sensor (Fig. 5) is located in the overdrive gear case. The sensor is positioned over the park gear and monitors transmission output shaft rotating speed. Speed sensor signals are triggered by the park gear lugs as they rotate past the sensor pickup face. Input signals from the sensor are sent to the transmission control module for processing. The vehicle speed sensor also serves as a backup for the transmission speed sensor. Signals from this sensor are shared with the powertrain control module.



J9321-411

Fig. 5 Transmission Output Speed Sensor

THROTTLE POSITION SENSOR (TPS)

The TPS provides throttle position input signals to the PCM. This input signal is used to determine overdrive and converter clutch shift schedule and to select the proper governor curve.

POWERTRAIN CONTROL MODULE (PCM)

The PCM controls operation of the converter clutch, overdrive clutch, and governor pressure solenoid.

The control module determines transmission shift points based on input signals from the transmission thermistor, transmission output shaft speed sensor, crankshaft position sensor, vehicle speed sensor, throttle position sensor, and battery temperature sensor.

GOVERNOR PRESSURE CURVES

There are four governor pressure curves programmed into the transmission control module. The different curves allow the control module to adjust governor pressure for varying conditions. One curve is used for operation when fluid temperature is at, or below, 1°C (30°F). A second curve is used when fluid temperature is at, or above, 10°C (50°F) during normal city or highway driving. A third curve is used during wide-open throttle operation. The fourth curve is used when driving with the transfer case in low range.

DESCRIPTION AND OPERATION (Continued)

SHIFT VALVE OPERATION

The shift valves are moved by a combination of throttle and governor pressure. The governor pressure is generated by electrical components.

The conditions under which a shift to fourth will not occur are:

- Overdrive switch is Off
- Transmission fluid temperature is below 10° C (50° F) or above 121° C (250° F)
- Shift to third not yet completed
- Vehicle speed too low for 3-4 shift to occur
- Battery temperature below -5° F.

HYDRAULIC CONTROL SYSTEM

The hydraulic control system provides fully automatic operation. The system performs five basic functions which are: pressure supply, pressure regulation, flow control, clutch/band application, and lubrication.

PRESSURE REGULATION

The pressure regulator valve maintains line pressure. The amount of pressure developed is controlled by throttle pressure which is dependent on the degree of throttle opening. The regulator valve is located in the valve body.

The throttle valve determines line pressure and shift speed. Governor pressure increases in proportion to vehicle speed. The throttle valve controls upshift and downshift speeds by regulating pressure according to throttle position.

Shift Valve Flow Control

The manual valve is operated by the gearshift linkage and provides the operating range selected by the driver.

The 1-2 shift valve provides 1-2 or 2-1 shifts and the 2-3 shift valve provides 2-3 or 3-2 shifts.

The kickdown valve provides forced 3-2 or 3-1 downshifts depending on vehicle speed. Downshifts occur when the throttle is opened beyond downshift detent position. Detent is reached just before wide open throttle position.

The 2-3 valve throttle pressure plug provides 3-2 downshifts at varying throttle openings depending on vehicle speed.

The 1-2 shift control valve transmits 1-2 shift pressure to the accumulator piston. This controls kickdown band capacity on 1-2 upshifts and 3-2 downshifts.

The 3-4 shift, quick fill, and timing valves plus the 3-4 accumulator, are only actuated when the overdrive solenoid is energized. The solenoid contains a check ball that controls a vent port to the 3-4 valves. The check ball either diverts line pressure away from or directly to the 3-4 valves.

The limit valve determines maximum speed at which a 3-2 part throttle kickdown can be made. On

transmissions without a limit valve, maximum speed for a 3-2 kickdown is at detent position.

The 2-3 shuttle valve has two functions. The first is fast front band release and smooth engagement during lift-foot 2-3 upshifts. The second is to regulate front clutch and band application during 3-2 downshifts.

The 3-4 timing valve is moved by line pressure coming through the 3-4 shift valve. The timing valve holds the 2-3 shift valve in an upshift position. The purpose is to prevent the 2-3 valve from up or downshifting before the 3-4 valve.

The 3-4 accumulator is mounted on the overdrive housing and performs the same function as the 2-3 accumulator; it is used to smooth engagement during a 3-4 shift.

The switch valve directs fluid apply pressure to the converter clutch in one position and releases it in the opposite position. It also directs oil to the cooling and lube circuits. The switch valve regulates oil pressure to the torque converter by limiting maximum oil pressure to 130 psi.

OVERDRIVE OFF SWITCH

The overdrive OFF (control) switch is located in the instrument panel. The switch is a momentary contact device that signals the PCM to toggle current status of the overdrive function. At key-on, overdrive operation is allowed. Pressing the switch once causes the overdrive OFF mode to be entered and the overdrive OFF switch lamp to be illuminated. Pressing the switch a second time causes normal overdrive operation to be restored and the overdrive lamp to be turned off. The overdrive OFF mode defaults to ON after the ignition switch is cycled OFF and ON. The normal position for the control switch is the ON position. The switch must be in this position to energize the solenoid and allow a 3-4 upshift. The control switch indicator light illuminates only when the overdrive switch is turned to the OFF position, or when illuminated by the transmission control module.

3-4 SHIFT SEQUENCE

The overdrive clutch is applied in fourth gear only. The direct clutch is applied in all ranges except fourth gear. Fourth gear overdrive range is electronically controlled and hydraulically activated. Various sensor inputs are supplied to the powertrain control module to operate the overdrive solenoid on the valve body. The solenoid contains a check ball that opens and closes a vent port in the 3-4 shift valve feed passage. The overdrive solenoid (and check ball) are not energized in first, second, third, or reverse gear. The vent port remains open, diverting line pressure from the 2-3 shift valve away from the 3-4 shift valve. The overdrive control switch must be in the ON position

DESCRIPTION AND OPERATION (Continued)

to transmit overdrive status to the PCM. A 3-4 upshift occurs only when the overdrive solenoid is energized by the PCM. The PCM energizes the overdrive solenoid during the 3-4 upshift. This causes the solenoid check ball to close the vent port allowing line pressure from the 2-3 shift valve to act directly on the 3-4 upshift valve. Line pressure on the 3-4 shift valve overcomes valve spring pressure moving the valve to the upshift position. This action exposes the feed passages to the 3-4 timing valve, 3-4 quick fill valve, 3-4 accumulator, and ultimately to the overdrive piston. Line pressure through the timing valve moves the overdrive piston into contact with the overdrive clutch. The direct clutch is disengaged before the overdrive clutch is engaged. The boost valve provides increased fluid apply pressure to the overdrive clutch during 3-4 upshifts, and when accelerating in fourth gear. The 3-4 accumulator cushions overdrive clutch engagement to smooth 3-4 upshifts. The accumulator is charged at the same time as apply pressure acts against the overdrive piston.

CONVERTER CLUTCH ENGAGEMENT

Converter clutch engagement in third or fourth gear range is controlled by sensor inputs to the powertrain control module. Inputs that determine clutch engagement are: coolant temperature, engine rpm, vehicle speed, throttle position, and manifold vacuum. The torque converter clutch is engaged by the clutch solenoid on the valve body. The clutch can be engaged in third and fourth gear ranges depending on overdrive control switch position. If the overdrive control switch is in the normal ON position, the clutch will engage after the shift to fourth gear, and above approximately 72 km/h (45 mph). If the control switch is in the OFF position, the clutch will engage after the shift to third gear, at approximately 56 km/h (35 mph) at light throttle.

QUICK FILL VALVE

The 3-4 quick fill valve provides faster engagement of the overdrive clutch during 3-4 upshifts. The valve temporarily bypasses the clutch piston feed orifice at the start of a 3-4 upshift. This exposes a larger passage into the piston retainer resulting in a much faster clutch fill and apply sequence. The quick fill valve does not bypass the regular clutch feed orifice throughout the 3-4 upshift. Instead, once a predetermined pressure develops within the clutch, the valve closes the bypass. Clutch fill is then completed through the regular feed orifice.

CONVERTER DRAINBACK VALVE

The drainback valve is located in the transmission cooler outlet (pressure) line. The valve prevents fluid from draining from the converter into the cooler and

lines when the vehicle is shut down for lengthy periods. Production valves have a hose nipple at one end, while the opposite end is threaded for a flare fitting. All valves have an arrow (or similar mark) to indicate direction of flow through the valve.

BRAKE TRANSMISSION SHIFT INTERLOCK MECHANISM

The Brake Transmission Shifter/Ignition Interlock (BTSI), is a cable and solenoid operated system. It interconnects the automatic transmission floor mounted shifter to the steering column ignition switch (Fig. 6). The system locks the shifter into the PARK position. The Interlock system is engaged whenever the ignition switch is in the LOCK or ACCESSORY position. An additional electrically activated feature will prevent shifting out of the PARK position unless the brake pedal is depressed at least one-half an inch. A magnetic holding device in line with the park lock cable is energized when the ignition is in the RUN position. When the key is in the RUN position and the brake pedal is depressed, the shifter is unlocked and will move into any position. The interlock system also prevents the ignition switch from being turned to the LOCK or ACCESSORY position (Fig. 7), unless the shifter is fully locked into the PARK position.

DIAGNOSIS AND TESTING**AUTOMATIC TRANSMISSION DIAGNOSIS**

Automatic transmission problems can be a result of poor engine performance, incorrect fluid level, incorrect linkage or cable adjustment, band or hydraulic control pressure adjustments, hydraulic system malfunctions or electrical/mechanical component malfunctions. Begin diagnosis by checking the easily accessible items such as: fluid level and condition, linkage adjustments and electrical connections. A road test will determine if further diagnosis is necessary.

PRELIMINARY DIAGNOSIS

Two basic procedures are required. One procedure for vehicles that are drivable and an alternate procedure for disabled vehicles (will not back up or move forward).

VEHICLE IS DRIVEABLE

- (1) Check for transmission fault codes using DRB scan tool.
- (2) Check fluid level and condition.
- (3) Adjust throttle and gearshift linkage if complaint was based on delayed, erratic, or harsh shifts.
- (4) Road test and note how transmission upshifts, downshifts, and engages.

DIAGNOSIS AND TESTING (Continued)

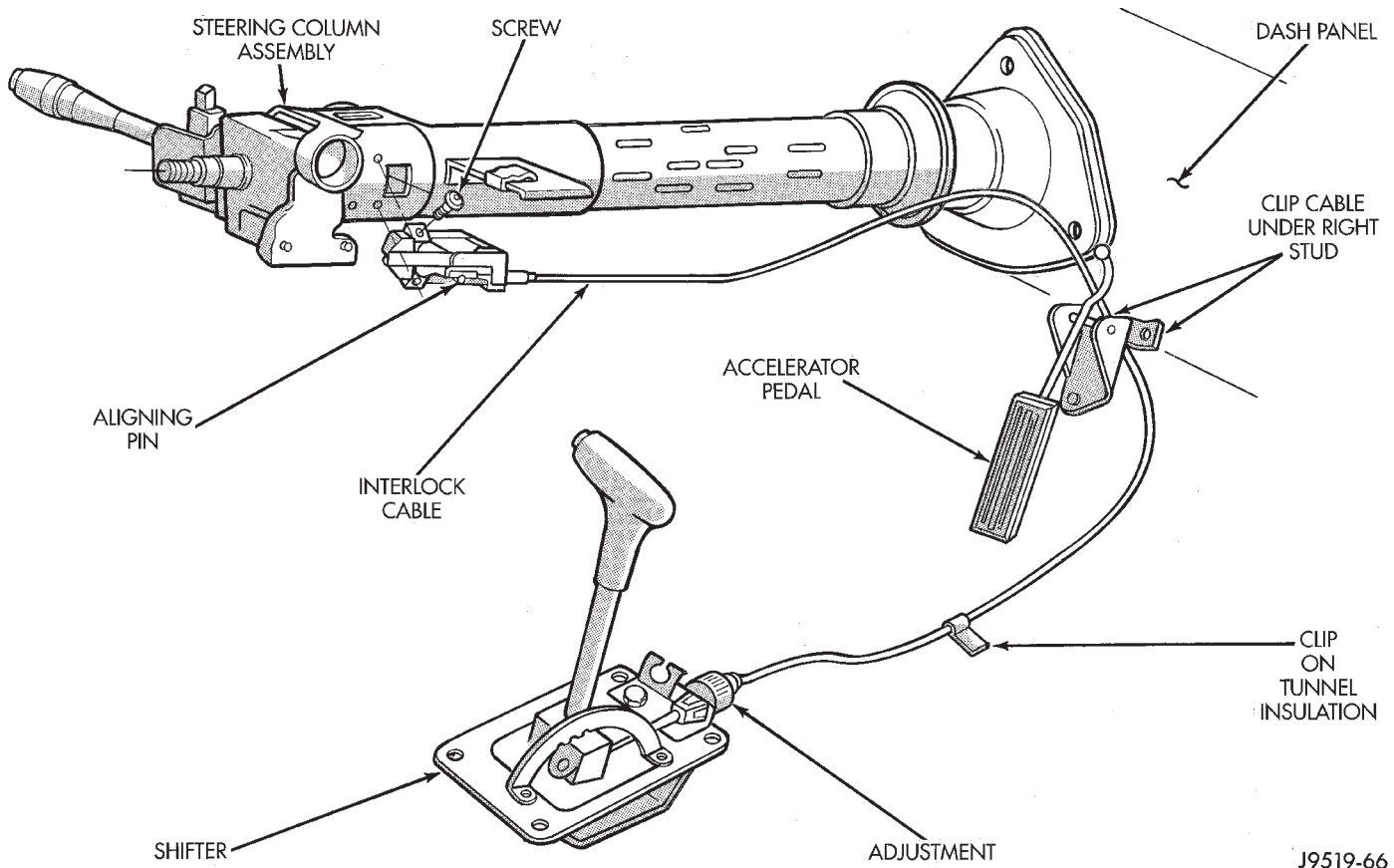


Fig. 6 Ignition Interlock Cable Routing

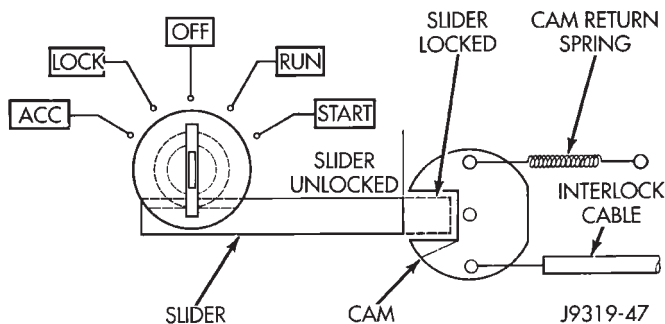


Fig. 7 Ignition Key Cylinder Actuation

(5) Perform stall test if complaint is based on sluggish acceleration. Or, if abnormal throttle opening is needed to maintain normal speeds with a properly tuned engine.

(6) Perform hydraulic pressure test if shift problems were noted during road test.

(7) Perform air-pressure test to check clutch-band operation.

VEHICLE IS DISABLED

(1) Check fluid level and condition.

(2) Check for broken or disconnected gearshift or throttle linkage.

(3) Check for cracked, leaking cooler lines, or loose or missing pressure-port plugs.

(4) Raise and support vehicle on safety stands, start engine, shift transmission into gear, and note following:

(a) If propeller shaft turns but wheels do not, problem is with differential or axle shafts.

(b) If propeller shaft does not turn and transmission is noisy, stop engine. Remove oil pan, and check for debris. If pan is clear, remove transmission and check for damaged drive plate, converter, oil pump, or input shaft.

(c) If propeller shaft does not turn and transmission is not noisy, perform hydraulic-pressure test to determine if problem is hydraulic or mechanical.

PARK/NEUTRAL POSITION SWITCH

The center terminal of the park/neutral position switch is the starter-circuit terminal. It provides the ground for the starter solenoid circuit through the selector lever in PARK and NEUTRAL positions only. The outer terminals on the switch are for the backup lamp circuit.

SWITCH TEST

To test the switch, remove the wiring connector. Test for continuity between the center terminal and

DIAGNOSIS AND TESTING (Continued)

the transmission case. Continuity should exist only when the transmission is in PARK or NEUTRAL.

Shift the transmission into REVERSE and test continuity at the switch outer terminals. Continuity should exist only when the transmission is in REVERSE. Continuity should not exist between the outer terminals and the case.

Check gearshift linkage adjustment before replacing a switch that tests faulty.

OVERDRIVE ELECTRICAL CONTROLS

The overdrive off switch, valve body solenoid, case connectors and related wiring can all be tested with a 12 volt test lamp or a volt/ohmmeter. Check continuity of each component when diagnosis indicates this is necessary. Refer to Group 8W, Wiring Diagrams, for component locations and circuit information.

Switch and solenoid continuity should be checked whenever the transmission fails to shift into fourth gear range.

BRAKE TRANSMISSION SHIFT INTERLOCK

(1) Verify that the key can only be removed in the PARK position

(2) When the shift lever is in PARK And the shift handle pushbutton is in the "OUT" position, the ignition key cylinder should rotate freely from OFF to LOCK. When the shifter is in any other gear or neutral position, the ignition key cylinder should not rotate to the LOCK position.

(3) Shifting out of PARK should be possible when the ignition key cylinder is in the OFF position.

(4) Shifting out of PARK should not be possible while applying 25 lb. maximum handle pushbutton force and ignition key cylinder is in the RUN or START positions unless the foot brake pedal is depressed approximately 1/2 inch (12mm).

(5) Shifting out of PARK should not be possible when the ignition key cylinder is in the ACCESSORY or LOCK positions.

(6) Shifting between any gears, NEUTRAL or into PARK may be done without depressing foot brake pedal with ignition switch in RUN or START positions and vehicle stationary or in motion.

GEARSHIFT CABLE

(1) The floor shifter lever and gate positions should be in alignment with all transmission PARK, NEUTRAL, and gear detent positions.

(2) Engine starts must be possible with floor shift lever in PARK or NEUTRAL gate positions only. Engine starts must not be possible in any other gear position.

(3) With floor shift lever handle push-button not depressed and lever in:

(a) PARK position—Apply forward force on center of handle and remove pressure. Engine starts must be possible.

(b) PARK position—Apply rearward force on center of handle and remove pressure. Engine starts must be possible.

(c) NEUTRAL position—Normal position. Engine starts must be possible.

(d) NEUTRAL position—Engine running and brakes applied, apply forward force on center of shift handle. Transmission shall not be able to shift from neutral to reverse.

THROTTLE VALVE CABLE

Transmission throttle valve cable adjustment is extremely important to proper operation. This adjustment positions the throttle valve, which controls shift speed, quality, and part-throttle downshift sensitivity.

If cable setting is too loose, early shifts and slippage between shifts may occur. If the setting is too tight, shifts may be delayed and part throttle downshifts may be very sensitive. Refer to the Adjustments section for the proper adjustment procedure.

ROAD TESTING

Before road testing, be sure the fluid level and control cable adjustments have been checked and adjusted if necessary. Verify that diagnostic trouble codes have been resolved.

Observe engine performance during the road test. A poorly tuned engine will not allow accurate analysis of transmission operation.

Operate the transmission in all gear ranges. Check for shift variations and engine flare which indicates slippage. Note if shifts are harsh, spongy, delayed, early, or if part throttle downshifts are sensitive.

Slippage indicated by engine flare, usually means clutch, band or overrunning clutch problems. If the condition is advanced, an overhaul will be necessary to restore normal operation.

A slipping clutch or band can often be determined by comparing which internal units are applied in the various gear ranges. The Clutch and Band Application chart provides a basis for analyzing road test results.

ANALYZING ROAD TEST

Refer to the Clutch and Band Application chart and note which elements are in use in the various gear ranges.

Note that the rear clutch is applied in all forward ranges (D, 2, 1). The transmission overrunning clutch is applied in first gear (D, 2 and 1 ranges) only. The rear band is applied in 1 and R range only.

Note that the overdrive clutch is applied only in fourth gear and the overdrive direct clutch and over-

DIAGNOSIS AND TESTING (Continued)

SHIFT LEVER POSITION	TRANSMISSION CLUTCHES AND BANDS					OVERDRIVE CLUTCHES		
	FRONT CLUTCH	FRONT BAND	REAR CLUTCH	REAR BAND	OVERRUN. CLUTCH	OVERDRIVE CLUTCH	DIRECT CLUTCH	OVERRUN. CLUTCH
Reverse	X			X			X	
Drive Range								
First			X		X		X	X
Second		X	X				X	X
Third	X		X				X	X
Fourth	X		X			X		
2-Range (Manual Second)		X	X		X		X	X
1-Range (Manual Low)			X	X	X		X	X

J9421-218

Clutch And Band Application Chart

running clutch are applied in all ranges except fourth gear.

For example: If slippage occurs in first gear in D and 2 range but not in 1 range, the transmission overrunning clutch is faulty. Similarly, if slippage occurs in any two forward gears, the rear clutch is slipping.

Applying the same method of analysis, note that the front and rear clutches are applied simultaneously only in D range third and fourth gear. If the transmission slips in third gear, either the front clutch or the rear clutch is slipping.

If the transmission slips in fourth gear but not in third gear, the overdrive clutch is slipping. By selecting another gear which does not use these clutches, the slipping unit can be determined. For example, if the transmission also slips in Reverse, the front clutch is slipping. If the transmission does not slip in Reverse, the rear clutch is slipping.

If slippage occurs during the 3-4 shift or only in fourth gear, the overdrive clutch is slipping. Similarly, if the direct clutch were to fail, the transmission would lose both reverse gear and overdrive braking in 2 position (manual second gear).

If the transmission will not shift to fourth gear, the control switch, overdrive solenoid or related wiring may also be the problem cause.

This process of elimination can be used to identify a slipping unit and check operation. Proper use of the Clutch and Band Application Chart is the key.

Although road test analysis will help determine the slipping unit, the actual cause of a malfunction usu-

ally cannot be determined until hydraulic and air pressure tests are performed. Practically any condition can be caused by leaking hydraulic circuits or sticking valves.

Unless a malfunction is obvious, such as no drive in D range first gear, do not disassemble the transmission. Perform the hydraulic and air pressure tests to help determine the probable cause.

HYDRAULIC PRESSURE TEST

Hydraulic test pressures range from a low of one psi (6.895 kPa) governor pressure, to 300 psi (2068 kPa) at the rear servo pressure port in reverse.

An accurate tachometer and pressure test gauges are required. Test Gauge C-3292 has a 100 psi range and is used at the accumulator, governor, and front servo ports. Test Gauge C-3293-SP has a 300 psi range and is used at the rear servo and overdrive ports where pressures exceed 100 psi.

Pressure Test Port Locations

Test ports are located at both sides of the transmission case (Fig. 8).

Line pressure is checked at the accumulator port on the right side of the case. The front servo pressure port is at the right side of the case just behind the filler tube opening.

The rear servo and governor pressure ports are at the right rear of the transmission case. The overdrive clutch pressure port is at the left rear of the case.

DIAGNOSIS AND TESTING (Continued)

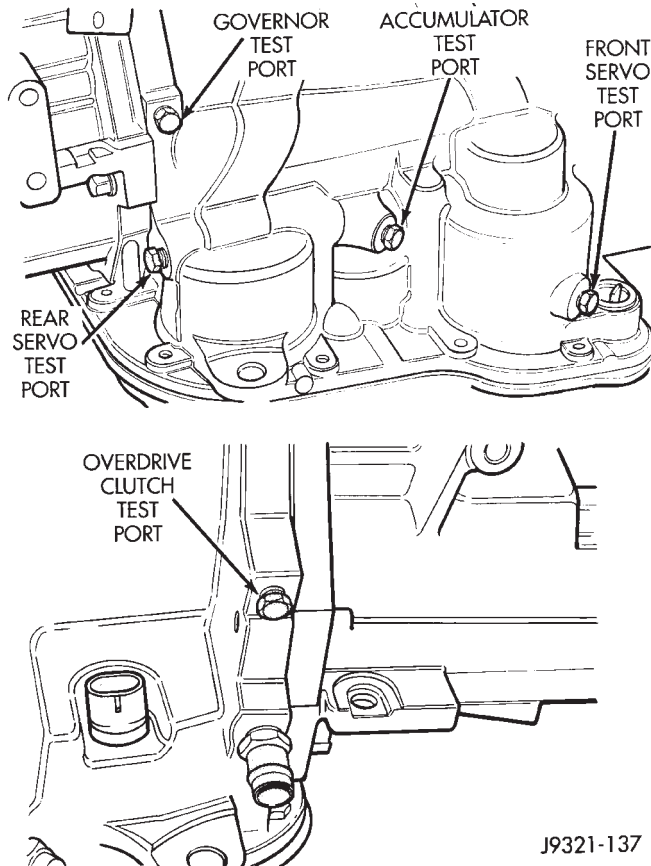


Fig. 8 Pressure Test Port Locations

Test One - Transmission In Manual Low

NOTE: This test checks pump output, pressure regulation, and condition of the rear clutch and servo circuit. Both test gauges are required for this test.

- (1) Connect tachometer to engine. Position tachometer so it can be observed from driver seat if helper will be operating engine. Raise vehicle on hoist that will allow rear wheels to rotate freely.
- (2) Connect 100 psi Gauge C-3292 to accumulator port. Then connect 300 psi Gauge C-3293-SP to rear servo port.
- (3) Disconnect throttle and gearshift cables from levers on transmission valve body manual shaft.
- (4) Have helper start and run engine at 1000 rpm.
- (5) Move transmission shift lever fully forward into 1 range.
- (6) Gradually move transmission throttle lever from full forward to full rearward position and note pressures on both gauges:
 - Line pressure at accumulator port should be 54-60 psi (372-414 kPa) with throttle lever forward and gradually increase to 90-96 psi (621-662 kPa) as throttle lever is moved rearward.
 - Rear servo pressure should be same as line pressure within 3 psi (20.68 kPa).

Test Two—Transmission In 2 Range

NOTE: This test checks pump output, line pressure and pressure regulation. Use 100 psi Test Gauge C-3292 for this test.

- (1) Leave vehicle in place on hoist and leave Test Gauge C-3292 connected to accumulator port.
- (2) Have helper start and run engine at 1000 rpm.
- (3) Move transmission shift lever one detent rearward from full forward position. This is 2 range.
- (4) Move transmission throttle lever from full forward to full rearward position and read pressure on gauge.
- (5) Line pressure should be 54-60 psi (372-414 kPa) with throttle lever forward and gradually increase to 90-96 psi (621-662 kPa) as lever is moved rearward.

Test Three—Transmission In D Range Third Gear

NOTE: This test checks pressure regulation and condition of the clutch circuits. Both test gauges are required for this test.

- (1) Turn OD switch off.
- (2) Leave vehicle on hoist and leave Gauge C-3292 in place at accumulator port.
- (3) Move Gauge C-3293-SP over to front servo port for this test.
- (4) Have helper start and run engine at 1600 rpm for this test.
- (5) Move transmission shift lever two detents rearward from full forward position. This is D range.
- (6) Read pressures on both gauges as transmission throttle lever is gradually moved from full forward to full rearward position:
 - Line pressure at accumulator in D range third gear, should be 54-60 psi (372-414 kPa) with throttle lever forward and increase as lever is moved rearward.
 - Front servo pressure in D range third gear, should be within 3 psi (21 kPa) of line pressure up to kickdown point.

Test Four—Transmission In Reverse

NOTE: This test checks pump output, pressure regulation and the front clutch and rear servo circuits. Use 300 psi Test Gauge C-3293-SP for this test.

- (1) Leave vehicle on hoist and leave gauge C3292 in place at accumulator port.
- (2) Move 300 psi Gauge C-3293-SP back to rear servo port.
- (3) Have helper start and run engine at 1600 rpm for test.

DIAGNOSIS AND TESTING (Continued)

(4) Move transmission shift lever four detents rearward from full forward position. This is Reverse range.

(5) Move transmission throttle lever fully forward then fully rearward and note reading at Gauge C-3293-SP.

(6) Pressure should be 145 - 175 psi (1000-1207 kPa) with throttle lever forward and increase to 230 - 280 psi (1586-1931 kPa) as lever is gradually moved rearward.

Test Five—Governor Pressure

NOTE: This test checks governor operation by measuring governor pressure response to changes in vehicle speed. It is usually not necessary to check governor operation unless shift speeds are incorrect or if the transmission will not downshift. The test should be performed on the road or on a hoist that will allow the rear wheels to rotate freely.

(1) Move 100 psi Test Gauge C-3292 to governor pressure port.

(2) Move transmission shift lever two detents rearward from full forward position. This is D range.

(3) Have helper start and run engine at curb idle speed. Then firmly apply service brakes so wheels will not rotate.

(4) Note governor pressure:

- Governor pressure should be no more than 20.6 kPa (3 psi) at curb idle speed and wheels not rotating.

- If pressure exceeds 20.6 kPa (3 psi), a fault exists in governor pressure control system.

(5) Release brakes, slowly increase engine speed, and observe speedometer and pressure test gauge (do not exceed 30 mph on speedometer). Governor pressure should increase in proportion to vehicle speed. Or approximately 6.89 kPa (1 psi) for every 1 mph.

(6) Governor pressure rise should be smooth and drop back to no more than 20.6 kPa (3 psi), after engine returns to curb idle and brakes are applied to prevent wheels from rotating.

(7) Compare results of pressure test with analysis chart.

Test Six—Transmission In Overdrive Fourth Gear

NOTE: This test checks line pressure at the overdrive clutch in fourth gear range. Use 300 psi Test Gauge C-3292 for this test. The test should be performed on the road or on a chassis dyno.

(1) Remove tachometer; it is not needed for this test.

(2) Move 300 psi Gauge to overdrive clutch pressure test port. Then remove other gauge and reinstall test port plug.

(3) Lower vehicle.

(4) Turn OD switch on.

(5) Secure test gauge so it can be viewed from drivers seat.

(6) Start engine and shift into D range.

(7) Increase vehicle speed gradually until 3-4 shift occurs and note gauge pressure.

(8) Pressure should be 469-496 kPa (68-72 psi) with closed throttle and increase to 620-827 kPa (90-120 psi) at 1/2 to 3/4 throttle. Note that pressure can increase to around 896 kPa (130 psi) at full throttle.

(9) Return to shop or move vehicle off chassis dyno.

PRESSURE TEST ANALYSIS CHART

TEST CONDITION	INDICATION
Line pressure OK during any one test	Pump and regulator valve OK
Line pressure OK in R but low in D, 2, 1	Leakage in rear clutch area (seal rings, clutch seals)
Pressure low in D Fourth Gear Range	Overdrive clutch piston seal, or check ball problem
Pressure OK in 1, 2 but low in D3 and R	Leakage in front clutch area
Pressure OK in 2 but low in R and 1	Leakage in rear servo
Front servo pressure low in 2	Leakage in servo; broken servo ring or cracked servo piston
Pressure low in all positions	Clogged filter, stuck regulator valve, worn or faulty pump, low oil level
Governor pressure too high at idle speed	Governor pressure solenoid valve system fault. Refer to diagnostic book.
Governor pressure low at all mph figures	Faulty governor pressure solenoid, transmission control module, or governor pressure sensor
Lubrication pressure low at all throttle positions	Clogged fluid cooler or lines, seal rings leaking, worn pump bushings, pump, clutch retainer, or clogged filter.
Line pressure high	Output shaft plugged, sticky regulator valve
Line pressure low	Sticky regulator valve, clogged filter, worn pump

DIAGNOSIS AND TESTING (Continued)

CONVERTER STALL TEST

Stall testing involves determining maximum engine speed obtainable at full throttle with the rear wheels locked and the transmission in D range. This test checks the holding ability of the converter overrunning and transmission clutches.

WARNING: NEVER ALLOW ANYONE TO STAND DIRECTLY IN LINE WITH THE VEHICLE FRONT OR REAR DURING A STALL TEST. ALWAYS BLOCK THE WHEELS AND FULLY APPLY THE SERVICE AND PARKING BRAKES DURING THE TEST.

STALL TEST PROCEDURE

- (1) Connect tachometer to engine. Position tachometer so it can be viewed from driver's seat.
- (2) Drive vehicle to bring transmission fluid up to normal operating temperature. Vehicle can be driven on road or on chassis dynamometer, if available.
- (3) Check transmission fluid level. Add fluid if necessary.
- (4) Block front wheels.
- (5) Fully apply service and parking brakes.
- (6) Open throttle completely and record maximum engine speed registered on tachometer. It takes 4-10 seconds to reach max rpm. **Once max rpm has been achieved, do not hold wide open throttle for more than 4-5 seconds.**

CAUTION: Stalling the converter causes a rapid increase in fluid temperature. To avoid fluid overheating, hold the engine at maximum rpm for no more than 5 seconds. If engine exceeds 2500 rpm during the test, release the accelerator pedal immediately; transmission clutch slippage is occurring.

- (7) If a second stall test is required, cool down fluid before proceeding. Shift into NEUTRAL and run engine at 1000 rpm for 20-30 seconds to cool fluid.

STALL TEST ANALYSIS

Stall Speed Too High

If the stall speed exceeds 2500 rpm, transmission clutch slippage is indicated.

Stall Speed Low

Low stall speed with a properly tuned engine indicate a torque converter overrunning clutch problem. The condition should be confirmed by road testing. A stall speed 250-350 rpm below normal indicates the converter overrunning clutch is slipping. The vehicle also exhibits poor acceleration but operates normally once highway cruise speeds are reached. Torque converter replacement will be necessary.

Stall Speed Normal But Acceleration Poor

If stall speeds are normal (1800-2300 rpm) but abnormal throttle opening is required for acceleration, or to maintain cruise speed, the converter overrunning clutch is seized. The torque converter will have to be replaced.

Converter Noise During Test

A whining noise caused by fluid flow is normal during a stall test. However, loud metallic noises indicate a damaged converter. To confirm that the noise is originating from the converter, operate the vehicle at light throttle in DRIVE and NEUTRAL on a hoist and listen for noise coming from the converter housing.

AIR TESTING TRANSMISSION CLUTCH AND BAND OPERATION

Air-pressure testing can be used to check transmission front/rear clutch and band operation. The test can be conducted with the transmission either in the vehicle or on the work bench, as a final check, after overhaul.

Air-pressure testing requires that the oil pan and valve body be removed from the transmission. The servo and clutch apply passages are shown (Fig. 9).

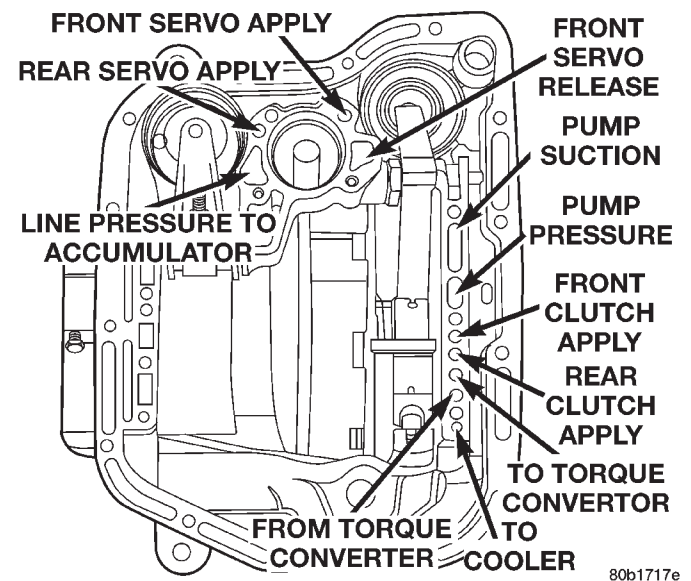


Fig. 9 Air Pressure Test Passages

Front Clutch Air Test

Place one or two fingers on the clutch housing and apply air pressure through front clutch apply passage. Piston movement can be felt and a soft thump heard as the clutch applies.

Rear Clutch Air Test

Place one or two fingers on the clutch housing and apply air pressure through rear clutch apply passage.

DIAGNOSIS AND TESTING (Continued)

Piston movement can be felt and a soft thump heard as the clutch applies.

Front Servo Air Test

Apply air pressure to the front servo apply passage. The servo rod should extend and cause the band to tighten around the drum. Spring pressure should release the servo when air pressure is removed.

Rear Servo Air Test

Apply air pressure to the rear servo apply passage. The servo rod should extend and cause the band to tighten around the drum. Spring pressure should release the servo when air pressure is removed.

CONVERTER HOUSING FLUID LEAK DIAGNOSIS

When diagnosing converter housing fluid leaks, two items must be established before repair.

- (1) Verify that a leak condition actually exists.
- (2) Determined the true source of the leak.

Some suspected converter housing fluid leaks may not be leaks at all. They may only be the result of residual fluid in the converter housing, or excess fluid spilled during factory fill or fill after repair. Converter housing leaks have several potential sources. Through careful observation, a leak source can be identified before removing the transmission for repair. Pump seal leaks tend to move along the drive hub and onto the rear of the converter. Pump O-ring or pump body leaks follow the same path as a seal leak (Fig. 10). Pump vent or pump attaching bolt leaks are generally deposited on the inside of the converter housing and not on the converter itself (Fig. 10). Pump seal or gasket leaks usually travel down the inside of the converter housing. Front band lever pin plug leaks are generally deposited on the housing and not on the converter.

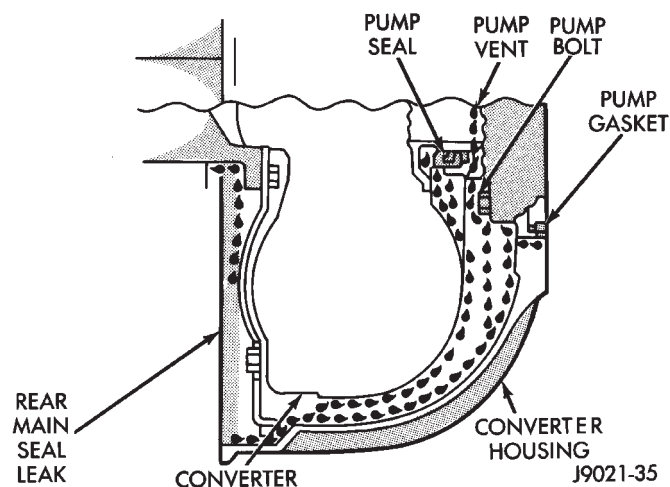


Fig. 10 Converter Housing Leak Paths

TORQUE CONVERTER LEAK POINTS

Possible sources of converter leaks are:

- (1) Leaks at the weld joint around the outside diameter weld (Fig. 11).
- (2) Leaks at the converter hub weld (Fig. 11).

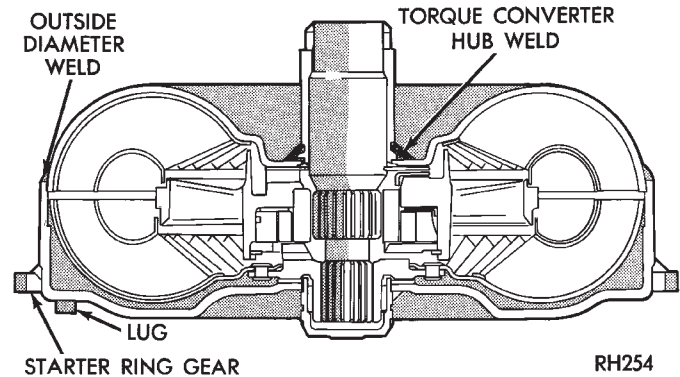


Fig. 11 Converter Leak Points—Typical

CONVERTER HOUSING AREA LEAK CORRECTION

- (1) Remove converter.
- (2) Tighten front band adjusting screw until band is tight around front clutch retainer. This prevents front/rear clutches from coming out when oil pump is removed.
- (3) Remove oil pump and remove pump seal. Inspect pump housing drainback and vent holes for obstructions. Clear holes with solvent and wire.
- (4) Inspect pump bushing and converter hub. If bushing is scored, replace it. If converter hub is scored, either polish it with crocus cloth or replace converter.
- (5) Install new pump seal, O-ring, and gasket. Replace oil pump if cracked, porous or damaged in any way. Be sure to loosen the front band before installing the oil pump, damage to the oil pump seal may occur if the band is still tightened to the front clutch retainer.
- (6) Loosen kickdown lever pin access plug three turns. Apply Loctite 592, or Permatex No. 2 to plug threads and tighten plug to 17 N·m (150 in. lbs.) torque.
- (7) Adjust front band.
- (8) Lubricate pump seal and converter hub with transmission fluid or petroleum jelly and install converter.
- (9) Install transmission and converter housing dust shield.
- (10) Lower vehicle.

DIAGNOSIS AND TESTING (Continued)

**DIAGNOSIS TABLES AND CHARTS—RE
TRANSMISSION**

The diagnosis charts provide additional reference when diagnosing a transmission fault. The charts provide general information on a variety of transmission, overdrive unit and converter clutch fault conditions.

The hydraulic flow charts in the Schematics and Diagrams section of this group, outline fluid flow and hydraulic circuitry. Circuit operation is provided for neutral, third, fourth and reverse gear ranges. Normal working pressures are also supplied for each of the gear ranges.

DIAGNOSIS CHARTS

CONDITION	POSSIBLE CAUSES	CORRECTION
HARSH ENGAGEMENT (FROM NEUTRAL TO DRIVE OR REVERSE)	1. Fluid Level Low	1. Add Fluid
	2. Throttle Linkage Misadjusted	2. Adjust linkage - setting may be too long.
	3. Mount and Driveline Bolts Loose	3. Check engine mount, transmission mount, propeller shaft, rear spring to body bolts, rear control arms, crossmember and axle bolt torque. Tighten loose bolts and replace missing bolts.
	4. U-Joint Worn/Broken	4. Remove propeller shaft and replace U-Joint.
	5. Axle Backlash Incorrect	5. Check per Service Manual. Correct as needed.
	6. Hydraulic Pressure Incorrect	6. Check pressure. Remove, overhaul or adjust valve body as needed.
	7. Band Misadjusted.	7. Adjust rear band.
	8. Valve Body Check Balls Missing.	8. Inspect valve body for proper check ball installation.
	9. Axle Pinion Flange Loose.	9. Replace nut and check pinion threads before installing new nut. Replace pinion gear if threads are damaged.
	10. Clutch, band or planetary component damaged.	10. Remove, disassemble and repair transmission as necessary.
	11. Converter Clutch Faulty.	11. Replace converter and flush cooler and line before installing new converter.

DIAGNOSIS AND TESTING (Continued)

CONDITION	POSSIBLE CAUSES	CORRECTION
DELAYED ENGAGEMENT (FROM NEUTRAL TO DRIVE OR REVERSE)	1. Fluid Level Low.	1. Correct level and check for leaks.
	2. Filter Clogged.	2. Change filter.
	3. Gearshift Linkage Misadjusted.	3. Adjust linkage and repair linkage if worn or damaged.
	4. Torque Converter Drain Back (Oil drains from torque converter into transmission sump)	4. If vehicle moves normally after 5 seconds after shifting into gear, no repair is necessary. If longer, inspect pump bushing for wear. Replace pump house.
	5. Rear Band Misadjusted.	5. Adjust band.
	6. Valve Body Filter Plugged.	6. Replace fluid and filter. If oil pan and old fluid were full of clutch disc material and/or metal particles, overhaul will be necessary.
	7. Oil Pump Gears Worn/Damaged.	7. Remove transmission and replace oil pump.
	8. Governor Circuit and Solenoid Valve Electrical Fault.	8. Test with DRB scan tool and repair as required.
	9. Hydraulic Pressure Incorrect.	9. Perform pressure test, remove transmission and repair as needed.
	10. Reaction Shaft Seal Rings Worn/Broken.	10. Remove transmission, remove oil pump and replace seal rings.
	11. Rear Clutch/Input Shaft, Rear Clutch Seal Rings Damaged.	11. Remove and disassemble transmission and repair as necessary.
	12. Regulator Valve Stuck.	12. Clean.
	13. Cooler Plugged.	13. Transfer case failure can plug cooler.
NO DRIVE RANGE (REVERSE OK)	1. Fluid Level Low.	1. Add fluid and check for leaks if drive is restored.
	2. Gearshift Linkage/Cable Loose/Misadjusted.	2. Repair or replace linkage components.
	3. Rear Clutch Burnt.	3. Remove and disassemble transmission and rear clutch and seals. Repair/replace worn or damaged parts as needed.
	4. Valve Body Malfunction.	4. Remove and disassemble valve body. Replace assembly if any valves or bores are damaged.
	5. Transmission Overrunning Clutch Broken.	5. Remove and disassemble transmission. Replace overrunning clutch.
	6. Input Shaft Seal Rings Worn/Damaged.	6. Remove and disassemble transmission. Replace seal rings and any other worn or damaged parts.
	7. Front Planetary Failed Broken.	7. Remove and repair.

DIAGNOSIS AND TESTING (Continued)

CONDITION	POSSIBLE CAUSES	CORRECTION
NO DRIVE OR REVERSE (VEHICLE WILL NOT MOVE)	1. Fluid Level Low.	1. Add fluid and check for leaks if drive is restored.
	2. Gearshift Linkage/Cable Loose/ Misadjusted.	2. Inspect, adjust and reassemble linkage as needed. Replace worn/ damaged parts.
	3. U-Joint/Axle/Transfer Case Broken.	3. Perform preliminary inspection procedure for vehicle that will not move. Refer to procedure in diagnosis section.
	4. Filter Plugged.	4. Remove and disassemble transmission. Repair or replace failed components as needed. Replace filter. If filter and fluid contained clutch material or metal particles, an overhaul may be necessary. Perform lube flow test. Flush oil. Replace cooler as necessary.
	5. Oil Pump Damaged.	5. Perform pressure test to confirm low pressure. Replace pump body assembly if necessary.
	6. Valve Body Malfunctioned.	6. Check and inspect valve body. Replace valve body (as assembly) if any valve or bore is damaged. Clean and reassemble correctly if all parts are in good condition.
	7. Transmission Internal Component Damaged.	7. Remove and disassemble transmission. Repair or replace failed components as needed.
	8. Park Sprag not Releasing - Check Stall Speed, Worn/Damaged/Stuck.	8. Remove, disassemble, repair.
	9. Torque Converter Damage.	9. Inspect and replace as required.

DIAGNOSIS AND TESTING (Continued)

CONDITION	POSSIBLE CAUSES	CORRECTION
SHIFTS DELAYED OR ERRATIC (SHIFTS ALSO HARSH AT TIMES)	1. Fluid Level Low/High.	1. Correct fluid level and check for leaks if low.
	2. Fluid Filter Clogged.	2. Replace filter. If filter and fluid contained clutch material or metal particles, an overhaul may be necessary. Perform lube flow test.
	3. Throttle Linkage Misadjusted.	3. Adjust linkage as described in service section.
	4. Throttle Linkage Binding.	4. Check cable for binding. Check for return to closed throttle at transmission.
	5. Gearshift Linkage/Cable Misadjusted.	5. Adjust linkage/cable as described in service section.
	6. Clutch or Servo Failure.	6. Remove valve body and air test clutch, and band servo operation. Disassemble and repair transmission as needed.
	7. Governor Circuit Electrical Fault.	7. Test using DRB scan tool and repair as required.
	8. Front Band Misadjusted.	8. Adjust band.
	9. Pump Suction Passage Leak.	9. Check for excessive foam on dipstick after normal driving. Check for loose pump bolts, defective gasket. Replace pump assembly if needed.
NO REVERSE (D RANGES OK)	1. Gearshift Linkage/Cable Misadjusted/Damaged.	1. Repair or replace linkage parts as needed.
	2. Park Sprag Sticking.	2. Replace overdrive annulus gear.
	3. Rear Band Misadjusted/Worn.	3. Adjust band; replace.
	4. Valve Body Malfunction.	4. Remove and service valve body. Replace valve body if any valves or valve bores are worn or damaged.
	5. Rear Servo Malfunction.	5. Remove and disassemble transmission. Replace worn/damaged servo parts as necessary.
	6. Direct Clutch in Overdrive Worn	6. Disassemble overdrive. Replace worn or damaged parts.
	7. Front Clutch Burnt.	7. Remove and disassemble transmission. Replace worn, damaged clutch parts as required.
HAS FIRST/REVERSE ONLY (NO 1-2 OR 2-3 UPSHIFT)	1. Governor Circuit Electrical Fault.	1. Test using DRB scan tool and repair as required.
	2. Valve Body Malfunction.	2. Repair stuck 1-2 shift valve or governor plug.
	3. Front Servo/Kickdown Band Damaged/Burned.	3. Repair/replace.

DIAGNOSIS AND TESTING (Continued)

CONDITION	POSSIBLE CAUSES	CORRECTION
MOVES IN 2ND OR 3RD GEAR, ABRUPTLY DOWNSHIFTS TO LOW	1. Valve Body Malfunction.	1. Remove, clean and inspect. Look for stuck 1-2 valve or governor plug.
	2. Governor Valve Sticking.	2. Remove, clean and inspect. Replace faulty parts.
NO LOW GEAR (MOVES IN 2ND OR 3RD GEAR ONLY)	1. Governor Valve Sticking.	1. Remove governor, clean, inspect and repair as required.
	2. Governor Circuit Electrical Fault.	2. Test with DRB scan tool and repair as required.
	3. Valve Body Malfunction.	3. Remove, clean and inspect. Look for sticking 1-2 shift valve, 2-3 shift valve, governor plug or broken springs.
	4. Front Servo Piston Cocked in Bore.	4. Inspect servo and repair as required.
	5. Front Band Linkage Malfunction	5. Inspect linkage and look for bind in linkage.
NO KICKDOWN OR NORMAL DOWNSHIFT	1. Throttle Linkage Misadjusted.	1. Adjust linkage.
	2. Accelerator Pedal Travel Restricted.	2. Verify floor mat is not under pedal, repair worn accelerator cable or bent brackets.
	3. Valve Body Hydraulic Pressures Too High or Too Low Due to Valve Body Malfunction or Incorrect Hydraulic Control Pressure Adjustments.	3. Perform hydraulic pressure tests to determine cause and repair as required. Correct valve body pressure adjustments as required.
	4. Governor Circuit Electrical Fault.	4. Test with DRB scan tool and repair as required.
	5. Valve Body Malfunction.	5. Perform hydraulic pressure tests to determine cause and repair as required. Correct valve body pressure adjustments as required.
	6. TPS Malfunction.	6. Replace sensor, check with DRB scan tool.
	7. PCM Malfunction.	7. Check with DRB scan tool and replace if required.
	8. Valve Body Malfunction.	8. Repair sticking 1-2, 2-3 shift valves, governor plugs, 3-4 solenoid, 3-4 shift valve, 3-4 timing valve.
STUCK IN LOW GEAR (WILL NOT UPSHIFT)	1. Throttle Linkage Misadjusted/Stuck.	1. Adjust linkage and repair linkage if worn or damaged. Check for binding cable or missing return spring.
	2. Gearshift Linkage Misadjusted.	2. Adjust linkage and repair linkage if worn or damaged.
	3. Governor Component Electrical Fault.	3. Check operating pressures and test with DRB scan tool, repair faulty component.
	4. Front Band Out of Adjustment.	4. Adjust Band.
	5. Clutch or Servo Malfunction.	5. Air pressure check operation of clutches and bands. Repair faulty component.

DIAGNOSIS AND TESTING (Continued)

CONDITION	POSSIBLE CAUSES	CORRECTION
CREEPS IN NEUTRAL	1. Gearshift Linkage Misadjusted.	1. Adjust linkage.
	2. Rear Clutch Dragging/Warped.	2. Disassemble and repair.
	3. Valve Body Malfunction.	3. Perform hydraulic pressure test to determine cause and repair as required.
BUZZING NOISE	1. Fluid Level Low	1. Add fluid and check for leaks.
	2. Shift Cable Misassembled.	2. Route cable away from engine and bell housing.
	3. Valve Body Misassembled.	3. Remove, disassemble, inspect valve body. Reassemble correctly if necessary. Replace assembly if valves or springs are damaged. Check for loose bolts or screws.
	4. Pump Passages Leaking	4. Check pump for porous casting, scores on mating surfaces and excess rotor clearance. Repair as required. Loose pump bolts.
	5. Cooling System Cooler Plugged.	5. Flow check cooler circuit. Repair as needed.
	6. Overrunning Clutch Damaged.	6. Replace clutch.
SLIPS IN REVERSE ONLY	1. Fluid Level Low.	1. Add fluid and check for leaks.
	2. Gearshift Linkage Misadjusted.	2. Adjust linkage.
	3. Rear Band Misadjusted.	3. Adjust band.
	4. Rear Band Worn.	4. Replace as required.
	5. Overdrive Direct Clutch Worn.	5. Disassemble overdrive. Repair as needed.
	6. Hydraulic Pressure Too Low.	6. Perform hydraulic pressure tests to determine cause.
	7. Rear Servo Leaking.	7. Air pressure check clutch-servo operation and repair as required.
	8. Band Linkage Binding.	8. Inspect and repair as required.

DIAGNOSIS AND TESTING (Continued)

CONDITION	POSSIBLE CAUSES	CORRECTION
SLIPS IN FORWARD DRIVE RANGES	1. Fluid Level Low.	1. Add fluid and check for leaks.
	2. Fluid Foaming.	2. Check for high oil level, bad pump gasket or seals, dirt between pump halves and loose pump bolts. Replace pump if necessary.
	3. Throttle Linkage Misadjusted.	3. Adjust linkage.
	4. Gearshift Linkage Misadjusted.	4. Adjust linkage.
	5. Rear Clutch Worn.	5. Inspect and replace as needed.
	6. Low Hydraulic Pressure Due to Worn Pump, Incorrect Control Pressure Adjustments, Valve Body Warpage or Malfunction, Sticking, Leaking Seal Rings, Clutch Seals Leaking, Servo Leaks, Clogged Filter or Cooler Lines	6. Perform hydraulic and air pressure tests to determine cause.
	7. Rear Clutch Malfunction, Leaking Seals or Worn Plates.	7. Air pressure check clutch-servo operation and repair as required.
	8. Overrunning Clutch Worn, Not Holding (Slips in 1 Only).	8. Replace Clutch.
SLIPS IN LOW GEAR "D" ONLY, BUT NO IN 1 POSITION	Overrunning Clutch Faulty.	Replace overrunning clutch.
GROWLING, GRATING OR SCRAPING NOISES	1. Drive Plate Broken.	1. Replace.
	2. Torque Converter Bolts Hitting Dust Shield.	2. Dust shield bent. Replace or repair.
	3. Planetary Gear Set Broken/Seized.	3. Check for debris in oil pan and repair as required.
	4. Overrunning Clutch Worn/Broken.	4. Inspect and check for debris in oil pan. Repair as required.
	5. Oil Pump Components Scored/Binding.	5. Remove, inspect and repair as required.
	6. Output Shaft Bearing or Bushing Damaged.	6. Remove, inspect and repair as required.
	7. Clutch Operation Faulty.	7. Perform air pressure check and repair as required.
	8. Front and Rear Bands Misadjusted.	8. Adjust bands.

DIAGNOSIS AND TESTING (Continued)

CONDITION	POSSIBLE CAUSES	CORRECTION
DRAGS OR LOCKS UP	1. Fluid Level Low.	1. Check and adjust level.
	2. Clutch Dragging/Failed	2. Air pressure check clutch operation and repair as required.
	3. Front or Rear Band Misadjusted.	3. Adjust bands.
	4. Case Leaks Internally.	4. Check for leakage between passages in case.
	5. Servo Band or Linkage Malfunction.	5. Air pressure check servo operation and repair as required.
	6. Overrunning Clutch Worn.	6. Remove and inspect clutch. Repair as required.
	7. Planetary Gears Broken.	7. Remove, inspect and repair as required (look for debris in oil pan).
	8. Converter Clutch Dragging.	8. Check for plugged cooler. Perform flow check. Inspect pump for excessive side clearance. Replace pump as required.
NO 4-3 DOWNSHIFT	1. Circuit Wiring and/or Connectors Shorted.	1. Test wiring and connectors with test lamp and volt/ohmmeter. Repair wiring as necessary. Replace connectors and/or harnesses as required.
	2. PCM Malfunction.	2. Check PCM operation with DRB scan tool. Replace PCM only if faulty.
	3. TPS Malfunction	3. Check TPS with DRB scan tool at PCM.
	4. Lockup Solenoid Not Venting.	4. Remove valve body and replace solenoid assembly if plugged or shorted.
	5. Overdrive Solenoid Not Venting.	5. Remove valve body and replace solenoid if plugged or shorted.
	6. Valve Body Valve Sticking.	6. Repair stuck 3-4 shift valve or lockup timing valve.
NO 4-3 DOWNSHIFT WHEN CONTROL SWITCH IS TURNED OFF	1. Control Switch Open/Shorted.	1. Test and replace switch if faulty.
	2. Overdrive Solenoid Connector Shorted.	2. Test solenoids and replace if seized or shorted.
	3. PCM Malfunction.	3. Test with DRB scan tool. Replace PCM if faulty.
	4. Valve Body Stuck Valves.	4. Repair stuck 3-4, lockup or lockup timing valve.
CLUNK NOISE FROM DRIVELINE ON CLOSED THROTTLE 4-3 DOWNSHIFT	1. Transmission Fluid Low.	1. Add Fluid.
	2. Throttle Cable Misadjusted.	2. Adjust cable.
	3. Overdrive Clutch Select Spacer Wrong Spacer.	3. Replace overdrive piston thrust plate spacer.

DIAGNOSIS AND TESTING (Continued)

CONDITION	POSSIBLE CAUSES	CORRECTION
3-4 UPSHIFT OCCURS IMMEDIATELY AFTER 2-3 SHIFT	1. Overdrive Solenoid Connector or Wiring Shorted.	1. Test connector and wiring for loose connections, shorts or ground and repair as needed.
	2. TPS Malfunction.	2. Test TPS and replace as necessary. Check with DRB scan tool.
	3. PCM Malfunction.	3. Test PCM with DRB scan tool and replace controller if faulty.
	4. Overdrive Solenoid Malfunction.	4. Replace solenoid.
	5. Valve Body Malfunction.	5. Remove, disassemble, clean and inspect valve body components. Make sure all valves and plugs slide freely in bores. Polish valves with crocus cloth if needed.
WHINE/NOISE RELATED TO ENGINE SPEED	1. Fluid Level Low.	1. Add fluid and check for leaks.
	2. Shift Cable Incorrect Routing.	2. Check shift cable for correct routing. Should not touch engine or bell housing.

DIAGNOSIS AND TESTING (Continued)

CONDITION	POSSIBLE CAUSES	CORRECTION
NO 3-4 UPSHIFT	1. Dash O/D Switch In OFF Position.	1. Turn control switch to ON position.
	2. Overdrive Circuit Fuse Blown.	2. Replace fuse. Determine why fuse failed and repair as necessary (i.e., shorts or grounds in circuit).
	3. O/D Switch Wire Shorted/Open Cut.	3. Check wires/connections with 12V test lamp and voltmeter. Repair damaged or loose wire/connection as necessary.
	4. Distance or Coolant Sensor Malfunction.	4. Test both sensors with test lamp or volt/ohmmeter and replace faulty sensor.
	5. TPS Malfunction.	5. Check with DRB scan tool and replace if necessary.
	6. Neutral Switch to PCM Wire Shorted/Cut.	6. Test switch as described in service section and replace if necessary. Engine no start.
	7. PCM Malfunction.	7. Check with DRB scan tool and replace if necessary.
	8. Overdrive Solenoid Shorted/Open.	8. Replace solenoid if shorted or open and repair loose or damaged wires (DRB scan tool).
	9. Solenoid Feed Orifice in Valve Body Blocked.	9. Remove, disassemble, and clean valve body thoroughly. Check feed orifice.
	10. Overdrive Clutch Failed.	10. Disassemble overdrive and repair as needed.
	11. Hydraulic Pressure Low.	11. Pressure test transmission to determine cause.
	12. Valve Body Valve Stuck.	12. Repair stuck 3-4 shift valve, 3-4 timing valve.
	13. O/D Piston Incorrect Spacer.	13. Remove unit, check end play and install correct spacer.
	14. Overdrive Piston Seal Failure.	14. Replace both seals.
	15. O/D Check Valve/Orifice Failed.	15. Check for free movement and secure assembly (in piston retainer). Check ball bleed orifice.

DIAGNOSIS AND TESTING (Continued)

CONDITION	POSSIBLE CAUSES	CORRECTION
SLIPS IN OVERDRIVE FOURTH GEAR	1. Fluid Level Low.	1. Add fluid and check for leaks.
	2. Overdrive Clutch Pack Worn.	2. Remove overdrive unit and rebuild clutch pack.
	3. Overdrive Piston Retainer Bleed Orifice Blown Out.	3. Disassemble transmission, remove retainer and replace orifice.
	4. Overdrive Piston or Seal Malfunction.	4. Remove overdrive unit. Replace seals if worn. Replace piston if damaged. If piston retainer is damaged, remove and disassemble the transmission.
	5. 3-4 Shift Valve, Timing Valve or Accumulator Malfunction.	5. Remove and overhaul valve body. Replace accumulator seals. Make sure all valves operate freely in bores and do not bind or stick. Make sure valve body screws are correctly tightened and separator plates are properly positioned.
	6. Overdrive Unit Thrust Bearing Failure.	6. Disassemble overdrive unit and replace thrust bearing (NO. 1 thrust bearing is between overdrive piston and clutch hub; NO. 2 thrust bearing is between the planetary gear and the direct clutch spring plate; NO. 3 thrust bearing is between overrunning clutch hub and output shaft).
	7. O/D Check Valve/Bleed Orifice Failure.	7. Check for function/secure orifice insert in O/D piston retainer.
DELAYED 3-4 UPSHIFT (SLOW TO ENGAGE)	1. Fluid Level Low.	1. Add fluid and check for leaks.
	2. Throttle Valve Cable Misadjusted.	2. Adjust throttle valve cable.
	3. Overdrive Clutch Pack Worn/Burnt.	3. Remove unit and rebuild clutch pack.
	4. TPS Faulty.	4. Test with DRB scan tool and replace TPS.
	5. Overdrive Clutch Bleed Orifice Plugged.	5. Disassemble transmission and replace orifice.
	6. Overdrive Solenoid or Wiring Shorted/Open.	6. Test solenoid and check wiring for loose/corroded connections or shorts/grounds. Replace solenoid if faulty and repair wiring if necessary.
	7. Overdrive Excess Clearance	7. Remove unit. Measure end play and select proper spacer.
	8. O/D Check Valve Missing or Stuck.	8. Check for presence of check valve. Repair or replace as required.
TORQUE CONVERTER LOCKS UP IN SECOND AND/OR THIRD GEAR	Lockup Solenoid, Relay or Wiring Shorted/Open.	Test solenoid, relay and wiring for continuity, shorts or grounds. Replace solenoid and relay if faulty. Repair wiring and connectors as necessary.

DIAGNOSIS AND TESTING (Continued)

CONDITION	POSSIBLE CAUSES	CORRECTION
HARSH 1-2, 2-3, 3-4 OR 3-2 SHIFTS	Lockup Solenoid Malfunction.	Remove valve body and replace solenoid assembly.
NO START IN PARK OR NEUTRAL	1. Gearshift Linkage/Cable Misadjusted.	1. Adjust linkage/cable.
	2. Neutral Switch Wire Open/Cut.	2. Check continuity with test lamp. Repair as required.
	3. Neutral Switch Faulty.	3. Refer to service section for test and replacement procedure.
	4. Neutral Switch Connect Faulty.	4. Connectors spread open. Repair.
	5. Valve Body Manual Lever Assembly Bent/Worn/Broken.	5. Inspect lever assembly and replace if damaged.
NO REVERSE (OR SLIPS IN REVERSE)	1. Direct Clutch Pack (front clutch) Worn.	1. Disassemble unit and rebuild clutch pack.
	2. Rear Band Misadjusted.	2. Adjust band.
	3. Front Clutch Malfunctioned/ Burned.	3. Air-pressure test clutch operation. Remove and rebuild if necessary.
	4. Overdrive Thrust Bearing Failure.	4. Disassemble geartrain and replace bearings.
	5. Direct Clutch Spring Collapsed/ Broken.	5. Remove and disassemble unit. Check clutch position and replace spring.

DIAGNOSIS AND TESTING (Continued)

CONDITION	POSSIBLE CAUSES	CORRECTION
OIL LEAKS.	1. Speedometer Adapter Leaks.	1. Replace both adapter seals.
	2. Fluid Lines and Fittings Loose/Leaks/Damaged.	2. Tighten fittings. If leaks persist, replace fittings and lines if necessary.
	3. Fill Tube (where tube enters case) Leaks/Damaged.	3. Replace O-ring seal. Inspect tube for cracks in fill tube.
	4. Pressure Port Plug Loose Loose/Damaged.	4. Tighten to correct torque. Replace plug or reseal if leak persists.
	5. Pan Gasket Leaks.	5. Tighten pan screws (150 in. lbs.). If leaks persist, replace gasket.
	6. Valve Body Manual Lever Shaft Seal Leaks/Worn.	6. Replace shaft seal.
	7. Rear Bearing Access Plate Leaks.	7. Replace gasket. Tighten screws.
	8. Gasket Damaged or Bolts are Loose.	8. Replace bolts or gasket or tighten both.
	9. Adapter/Extension Gasket Damaged Leaks/Damaged.	9. Replace gasket.
	10. Neutral Switch Leaks/Damaged.	10. Replace switch and gasket.
	11. Converter Housing Area Leaks.	11. Check for leaks at seal caused by worn seal or burr on converter hub (cutting seal), worn bushing, missing oil return, oil in front pump housing or hole plugged. Check for leaks past O-ring seal on pump or past pump-to-case bolts; pump housing porous, oil coming out vent due to overfill or leak past front band shaft access plug.
	12. Pump Seal Leaks/Worn/Damaged.	12. Replace seal.
	13. Torque Converter Weld Leak/Cracked Hub.	13. Replace converter.
	14. Case Porosity Leaks.	14. Replace case.
NOISY OPERATION IN FOURTH GEAR ONLY	1. Overdrive Clutch Discs, Plates or Snap Rings Damaged.	1. Remove unit and rebuild clutch pack.
	2. Overdrive Piston or Planetary Thrust Bearing Damaged.	2. Remove and disassemble unit. Replace either thrust bearing if damaged.
	3. Output Shaft Bearings Scored/Damaged.	3. Remove and disassemble unit. Replace either bearing if damaged.
	4. Planetary Gears Worn/Chipped.	4. Remove and overhaul overdrive unit.
	5. Overdrive Unit Overrunning Clutch Rollers Worn/Scored.	5. Remove and overhaul overdrive unit.

SERVICE PROCEDURES

FLUID LEVEL CHECK

Transmission fluid level should be checked monthly under normal operation. If the vehicle is used for trailer towing or similar heavy load hauling, check fluid level and condition weekly. Fluid level is checked with the engine running at curb idle speed, the transmission in NEUTRAL and the transmission fluid at normal operating temperature.

FLUID LEVEL CHECK PROCEDURE

- (1) Transmission fluid must be at normal operating temperature for accurate fluid level check. Drive vehicle if necessary to bring fluid temperature up to normal hot operating temperature of 82°C (180°F).
- (2) Position vehicle on level surface.
- (3) Start and run engine at curb idle speed.
- (4) Apply parking brakes.
- (5) Shift transmission momentarily into all gear ranges. Then shift transmission back to Neutral.
- (6) Clean top of filler tube and dipstick to keep dirt from entering tube.
- (7) Remove dipstick (Fig. 12) and check fluid level as follows:
 - (a) Correct acceptable level is in crosshatch area.
 - (b) Correct maximum level is to MAX arrow mark.
 - (c) Incorrect level is at or below MIN line.
 - (d) If fluid is low, add only enough Mopar® ATF Plus 3 to restore correct level. Do not overfill.

CAUTION: Do not overfill the transmission. Overfilling may cause leakage out the pump vent which can be mistaken for a pump seal leak. Overfilling will also cause fluid aeration and foaming as the excess fluid is picked up and churned by the gear train. This will significantly reduce fluid life.

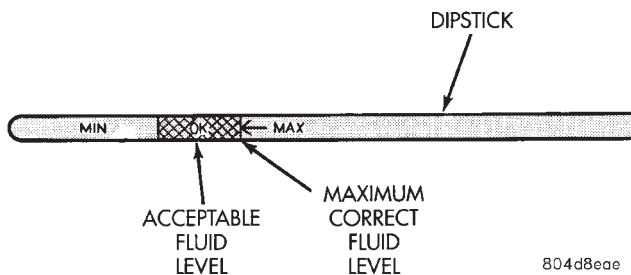


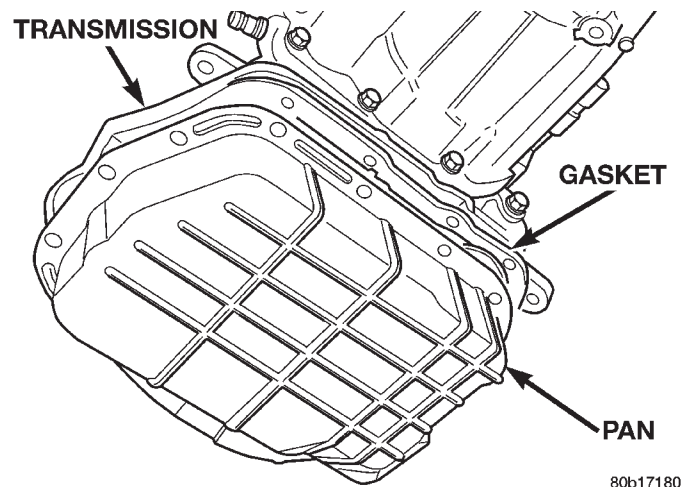
Fig. 12 Dipstick Fluid Level Marks—Typical

FLUID AND FILTER REPLACEMENT

Refer to the Maintenance Schedules in Group 0, Lubrication and Maintenance, for proper service intervals. The service fluid fill after a filter change is approximately 3.8 liters (4.0 quarts).

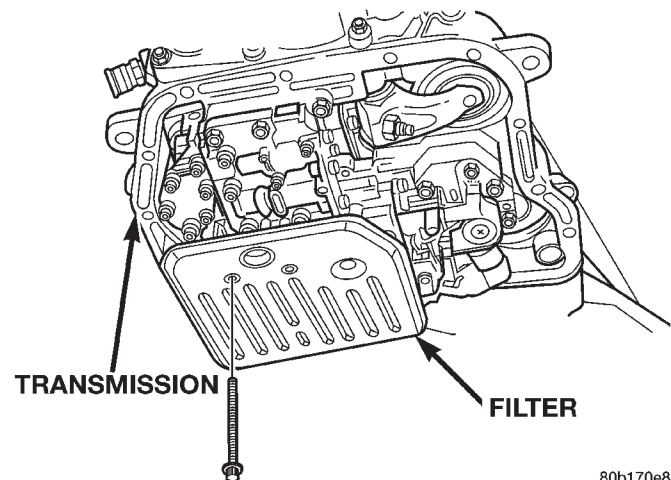
REMOVAL

- (1) Hoist and support vehicle on safety stands.
- (2) Place a large diameter shallow drain pan beneath the transmission pan.
- (3) Remove bolts holding front and sides of pan to transmission (Fig. 13).
- (4) Loosen bolts holding rear of pan to transmission.
- (5) Slowly separate front of pan away from transmission allowing the fluid to drain into drain pan.
- (6) Hold up pan and remove remaining bolt holding pan to transmission.
- (7) While holding pan level, lower pan away from transmission.
- (8) Pour remaining fluid in pan into drain pan.
- (9) Remove screws holding filter to valve body (Fig. 14).
- (10) Separate filter from valve body and pour fluid in filter into drain pan.
- (11) Dispose of used trans fluid and filter properly.



80b17180

Fig. 13 Transmission Pan



80b170e8

Fig. 14 Transmission Filter

SERVICE PROCEDURES (Continued)

INSPECTION

Inspect bottom of pan and magnet for excessive amounts of metal or fiber contamination. A light coating of clutch or band material on the bottom of the pan does not indicate a problem unless accompanied by slipping condition or shift lag. If fluid and pan are contaminated with excessive amounts or debris, refer to the diagnosis section of this group.

Check the adjustment of the front and rear bands, adjust if necessary.

CLEANING

(1) Using a suitable solvent, clean pan and magnet.

(2) Using a suitable gasket scraper, clean gasket material from gasket surface of transmission case and the gasket flange around the pan.

INSTALLATION

(1) Place replacement filter in position on valve body.

(2) Install screws to hold filter to valve body (Fig. 14). Tighten screws to 4 N·m (35 in. lbs.) torque.

(3) Place new gasket in position on pan and install pan on transmission.

(4) Place pan in position on transmission.

(5) Install screws to hold pan to transmission (Fig. 13). Tighten bolts to 17 N·m (150 in. lbs.) torque.

(6) Lower vehicle and fill transmission with Mopar® ATF Plus 3, type 7176 fluid.

TRANSMISSION FILL PROCEDURE

To avoid overfilling transmission after a fluid change or overhaul, perform the following procedure:

(1) Remove dipstick and insert clean funnel in transmission fill tube.

(2) Add following initial quantity of Mopar® ATF Plus 3 to transmission:

(a) If only fluid and filter were changed, add **3 pints (1-1/2 quarts)** of ATF Plus 3 to transmission.

(b) If transmission was completely overhauled, torque converter was replaced or drained, and cooler was flushed, add **12 pints (6 quarts)** of ATF Plus 3 to transmission.

(3) Apply parking brakes.

(4) Start and run engine at normal curb idle speed.

(5) Apply service brakes, shift transmission through all gear ranges then back to NEUTRAL, set parking brake, and leave engine running at curb idle speed.

(6) Remove funnel, insert dipstick and check fluid level. If level is low, **add fluid to bring level to MIN mark on dipstick.** Check to see if the oil level is equal on both sides of the dipstick. If one side is noticeably higher than the other, the dipstick has

picked up some oil from the dipstick tube. Allow the oil to drain down the dipstick tube and re-check.

(7) Drive vehicle until transmission fluid is at normal operating temperature.

(8) With the engine running at curb idle speed, the gear selector in NEUTRAL, and the parking brake applied, check the transmission fluid level.

CAUTION: Do not overfill transmission, fluid foaming and shifting problems can result.

(9) Add fluid to bring level up to MAX arrow mark.

When fluid level is correct, shut engine off, release park brake, remove funnel, and install dipstick in fill tube.

CONVERTER DRAINBACK CHECK VALVE SERVICE

The converter drainback check valve is located in the cooler outlet (pressure) line near the radiator lower tank. The valve prevents fluid drainback when the vehicle is parked for lengthy periods. The valve check ball is spring loaded and has an opening pressure of approximately 2 psi.

The valve is serviced as an assembly; it is not repairable. Do not clean the valve if restricted, or contaminated by sludge, or debris. If the valve fails, or if a transmission malfunction occurs that generates sludge and/or clutch particles and metal shavings, the valve must be replaced.

The valve must be removed whenever the cooler and lines are reverse flushed. The valve can be flow tested when necessary. The procedure is exactly the same as for flow testing a cooler.

If the valve is restricted, installed backwards, or in the wrong line, it will cause an overheating condition and possible transmission failure.

CAUTION: The drainback valve is a one-way flow device. It must be properly oriented in terms of flow direction for the cooler to function properly. The valve must be installed in the pressure line. Otherwise flow will be blocked and would cause an overheating condition and eventual transmission failure.

OIL PUMP VOLUME CHECK

After the new or repaired transmission has been installed, fill to the proper level with Mopar® ATF PLUS 3 (Type 7176) automatic transmission fluid. The volume should be checked using the following procedure:

(1) Disconnect the **From cooler** line at the transmission and place a collecting container under the disconnected line.

SERVICE PROCEDURES (Continued)

CAUTION: With the fluid set at the proper level, fluid collection should not exceed (1) quart or internal damage to the transmission may occur.

(2) Run the engine **at curb idle speed**, with the shift selector in neutral.

(3) If fluid flow is intermittent or it takes more than 20 seconds to collect one quart of ATF PLUS 3, disconnect the **To Cooler** line at the transaxle.

(4) Refill the transaxle to proper level and recheck pump volume.

(5) If flow is found to be within acceptable limits, replace the cooler. Then fill transmission to the proper level, using Mopar® ATF PLUS 3 (Type 7176) automatic transmission fluid.

(6) If fluid flow is still found to be inadequate, check the line pressure using the Transaxle Hydraulic Pressure Test procedure.

FLUSHING COOLERS AND TUBES

When a transmission failure has contaminated the fluid, the oil cooler(s) must be flushed. The cooler bypass valve in the transmission must be replaced also. The torque converter must also be replaced. This will insure that metal particles or sludged oil are not later transferred back into the reconditioned (or replaced) transmission.

The only recommended procedure for flushing coolers and lines is to use Tool 6906 Cooler Flusher.

WARNING: WEAR PROTECTIVE EYEWEAR THAT MEETS THE REQUIREMENTS OF OSHA AND ANSI Z87.1-1968. WEAR STANDARD INDUSTRIAL RUBBER GLOVES.

KEEP LIGHTED CIGARETTES, SPARKS, FLAMES, AND OTHER IGNITION SOURCES AWAY FROM THE AREA TO PREVENT THE IGNITION OF COMBUSTIBLE LIQUIDS AND GASES. KEEP A CLASS (B) FIRE EXTINGUISHER IN THE AREA WHERE THE FLUSHER WILL BE USED.

KEEP THE AREA WELL VENTILATED.

DO NOT LET FLUSHING SOLVENT COME IN CONTACT WITH YOUR EYES OR SKIN: IF EYE CONTAMINATION OCCURS, FLUSH EYES WITH WATER FOR 15 TO 20 SECONDS. REMOVE CONTAMINATED CLOTHING AND WASH AFFECTED SKIN WITH SOAP AND WATER. SEEK MEDICAL ATTENTION.

COOLER FLUSH USING TOOL 6906

(1) Remove cover plate filler plug on Tool 6906. Fill reservoir 1/2 to 3/4 full of fresh flushing solution. Flushing solvents are petroleum based solutions generally used to clean automatic transmission components. **DO NOT** use solvents containing acids, water, gasoline, or any other corrosive liquids.

(2) Reinstall filler plug on Tool 6906.

(3) Verify pump power switch is turned OFF. Connect red alligator clip to positive (+) battery post. Connect black (-) alligator clip to a good ground.

(4) Disconnect the cooler lines at the transmission.

NOTE: When flushing transmission cooler and lines, ALWAYS reverse flush.

(5) Connect the BLUE pressure line to the OUTLET (From) cooler line.

(6) Connect the CLEAR return line to the INLET (To) cooler line

(7) Turn pump ON for two to three minutes to flush cooler(s) and lines. Monitor pressure readings and clear return lines. Pressure readings should stabilize below 20 psi. for vehicles equipped with a single cooler and 30 psi. for vehicles equipped with dual coolers. If flow is intermittent or exceeds these pressures, replace cooler.

(8) Turn pump OFF.

(9) Disconnect CLEAR suction line from reservoir at cover plate. Disconnect CLEAR return line at cover plate, and place it in a drain pan.

(10) Turn pump ON for 30 seconds to purge flushing solution from cooler and lines. Turn pump OFF.

(11) Place CLEAR suction line into a one quart container of Mopar® ATF Plus 3, type 7176 automatic transmission fluid.

(12) Turn pump ON until all transmission fluid is removed from the one quart container and lines. This purges any residual cleaning solvent from the transmission cooler and lines. Turn pump OFF.

(13) Disconnect alligator clips from battery. Reconnect flusher lines to cover plate, and remove flushing adapters from cooler lines.

ALUMINUM THREAD REPAIR

Damaged or worn threads in the aluminum transaxle case and valve body can be repaired by the use of Heli-Coils, or equivalent. This repair consists of drilling out the worn-out damaged threads. Then tap the hole with a special Heli-Coil tap, or equivalent, and installing a Heli-Coil insert, or equivalent, into the hole. This brings the hole back to its original thread size.

Heli-Coil, or equivalent, tools and inserts are readily available from most automotive parts suppliers.

REMOVAL AND INSTALLATION

TRANSMISSION

The overdrive unit can be removed and serviced separately. It is not necessary to remove the entire transmission assembly to perform overdrive unit repairs.

REMOVAL AND INSTALLATION (Continued)

If only the overdrive unit requires service, refer to the overdrive unit removal and installation procedures.

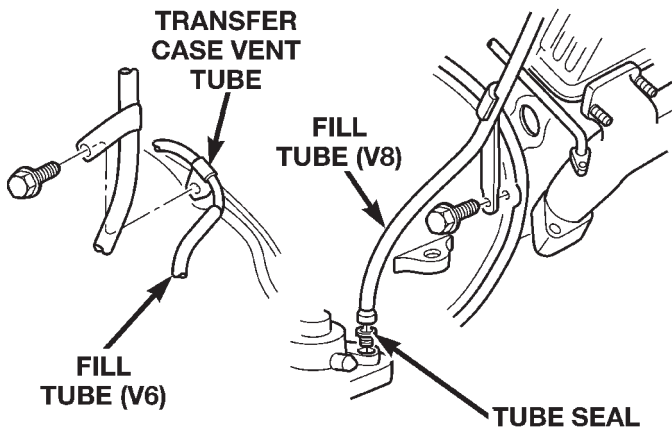
CAUTION: The transmission and torque converter must be removed as an assembly to avoid component damage. The converter drive plate, pump bushing, or oil seal can be damaged if the converter is left attached to the driveplate during removal. Be sure to remove the transmission and converter as an assembly.

REMOVAL

- (1) Disconnect battery negative cable.
- (2) Disconnect and lower or remove necessary exhaust components.
- (3) Remove engine-to-transmission bending braces.
- (4) Disconnect fluid cooler lines at transmission.
- (5) Remove starter motor.
- (6) Disconnect and remove crankshaft position sensor. Retain sensor attaching bolts.

CAUTION: The crankshaft position sensor will be damaged if the transmission is removed, or installed, while the sensor is still bolted to the engine block, or transmission (4.0L only). To avoid damage, be sure to remove the sensor before removing the transmission.

- (7) Remove torque converter access cover.
- (8) If transmission is being removed for overhaul, remove transmission oil pan, drain fluid and reinstall pan.
- (9) Remove fill tube bracket bolts and pull tube out of transmission. Retain fill tube seal. On 4 x 4 models, it will also be necessary to remove bolt attaching transfer case vent tube to converter housing (Fig. 15).



80b170f3

Fig. 15 Fill Tube Attachment

(10) Mark torque converter and drive plate for assembly alignment. Note that bolt holes in crankshaft flange, drive plate and torque converter all have one offset hole.

(11) Rotate crankshaft in clockwise direction until converter bolts are accessible. Then remove bolts one at a time. Rotate crankshaft with socket wrench on dampener bolt.

(12) Mark propeller shaft and axle yokes for assembly alignment. Then disconnect and remove propeller shaft. On 4 x 4 models, remove both propeller shafts.

(13) Disconnect wires from park/neutral position switch, transmission solenoid, and vehicle speed sensor.

(14) Disconnect gearshift cable from transmission manual valve lever.

(15) Disconnect throttle valve cable from transmission bracket and throttle valve lever.

(16) On 4 x 4 models, disconnect shift rod from transfer case shift lever or remove shift lever from transfer case.

(17) Disconnect transmission fluid cooler lines at transmission fittings and clips.

(18) Support rear of engine with safety stand or jack.

(19) Raise transmission slightly with service jack to relieve load on crossmember and supports.

(20) Remove bolts securing rear support and cushion to transmission and crossmember. Raise transmission slightly, slide exhaust hanger arm from bracket and remove rear support.

(21) Remove bolts attaching crossmember to frame and remove crossmember.

(22) On 4 x 4 models, remove transfer case.

(23) Remove all converter housing bolts.

(24) Carefully work transmission and torque converter assembly rearward off engine block dowels.

(25) Hold torque converter in place during transmission removal.

(26) Lower transmission and remove assembly from under the vehicle.

(27) To remove torque converter, carefully slide torque converter out of the transmission.

INSTALLATION

(1) Check torque converter hub and hub drive notches for sharp edges burrs, scratches, or nicks. Polish the hub and notches with 320/400 grit paper and crocus cloth if necessary. The hub must be smooth to avoid damaging pump seal at installation.

(2) Lubricate converter drive hub and oil pump seal lip with transmission fluid.

(3) Lubricate converter pilot hub with transmission fluid.

(4) Align converter and oil pump.

REMOVAL AND INSTALLATION (Continued)

(5) Carefully insert converter in oil pump. Then rotate converter back and forth until fully seated in pump gears.

(6) Check converter seating with steel scale and straightedge (Fig. 16). Surface of converter lugs should be 1/2 in. to rear of straightedge when converter is fully seated.

(7) Temporarily secure converter with C-clamp.

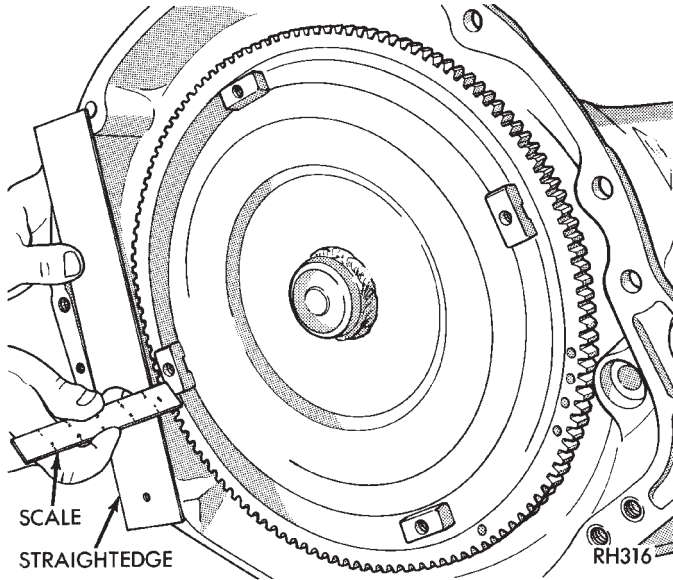


Fig. 16 Typical Method Of Checking Converter Seating

(8) Position transmission on jack and secure it with chains.

(9) Check condition of converter driveplate. Replace the plate if cracked, distorted or damaged. **Also be sure transmission dowel pins are seated in engine block and protrude far enough to hold transmission in alignment.**

(10) Raise transmission and align converter with drive plate and converter housing with engine block.

(11) Move transmission forward. Then raise, lower or tilt transmission to align converter housing with engine block dowels.

(12) Rotate converter so alignment marks scribed on converter are aligned with mark on driveplate.

(13) Carefully work transmission forward and over engine block dowels until converter hub is seated in crankshaft.

(14) Install bolts attaching converter housing to engine.

(15) Install rear support. Then lower transmission onto crossmember and install bolts attaching transmission mount to crossmember.

(16) Remove engine support fixture.

(17) Install crankshaft position sensor.

(18) Install vehicle speed sensor and speedometer adapter.

(19) Install new plastic retainer grommet on any shift linkage rod or lever that was disconnected. Grommets should not be reused. Use pry tool to remove rod from grommet and cut away old grommet. Use pliers to snap new grommet into lever and to snap rod into grommet at assembly.

(20) Connect gearshift and throttle valve cable to transmission.

(21) Connect wires to park/neutral position switch, transmission solenoid(s) and oxygen sensor. Be sure transmission harnesses are properly routed.

CAUTION: It is essential that correct length bolts be used to attach the converter to the driveplate. Bolts that are too long will damage the clutch surface inside the converter.

(22) Install torque converter-to-driveplate bolts. Tighten bolts to 31 N·m (270 in. lbs.).

(23) Install converter housing access cover.

(24) Install starter motor and cooler line bracket.

(25) Connect cooler lines to transmission.

(26) Install transmission fill tube. Install new seal on tube before installation.

(27) Install exhaust components.

(28) Install transfer case.

(29) Align and connect propeller shaft(s).

(30) Adjust gearshift linkage and throttle valve cable if necessary.

(31) Lower vehicle.

(32) Fill transmission with Mopar® ATF Plus 3, Type 7176 fluid.

TORQUE CONVERTER**REMOVAL**

(1) Remove transmission and torque converter from vehicle.

(2) Place a suitable drain pan under the converter housing end of the transmission.

CAUTION: Verify that transmission is secure on the lifting device or work surface, the center of gravity of the transmission will shift when the torque converter is removed creating an unstable condition.

The torque converter is a heavy unit. Use caution when separating the torque converter from the transmission.

(3) Pull the torque converter forward until the center hub clears the oil pump seal.

(4) Separate the torque converter from the transmission.

INSTALLATION

Check converter hub and drive notches for sharp edges, burrs, scratches, or nicks. Polish the hub and

REMOVAL AND INSTALLATION (Continued)

notches with 320/400 grit paper or crocus cloth if necessary. The hub must be smooth to avoid damaging the pump seal at installation.

- (1) Lubricate converter hub and oil pump seal lip with transmission fluid.
- (2) Place torque converter in position on transmission.

CAUTION: Do not damage oil pump seal or bushing while inserting torque converter into the front of the transmission.

- (3) Align torque converter to oil pump seal opening.
- (4) Insert torque converter hub into oil pump.
- (5) While pushing torque converter inward, rotate converter until converter is fully seated in the oil pump gears.
- (6) Check converter seating with a scale and straightedge (Fig. 17). Surface of converter lugs should be 1/2 in. to rear of straightedge when converter is fully seated.
- (7) If necessary, temporarily secure converter with C-clamp attached to the converter housing.
- (8) Install the transmission in the vehicle.
- (9) Fill the transmission with the recommended fluid.

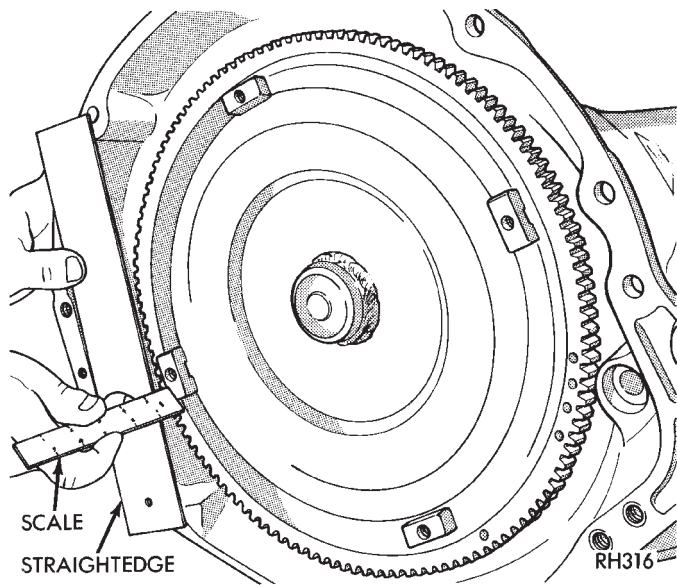


Fig. 17 Checking Torque Converter Seating

YOKE SEAL REPLACEMENT

REMOVAL

- (1) Raise vehicle.
- (2) Mark propeller shaft and axle yoke for alignment reference.
- (3) Disconnect and remove propeller shaft.
- (4) Remove old seal with Seal Remover C-3985-B (Fig. 18) from overdrive housing.

INSTALLATION

- (1) Place seal in position on overdrive housing.
- (2) Drive seal into overdrive housing with Seal Installer C-3995-A (Fig. 19).
- (3) Carefully guide propeller shaft slip yoke into housing and onto output shaft splines. Align marks made at removal and connect propeller shaft to rear axle pinion yoke.

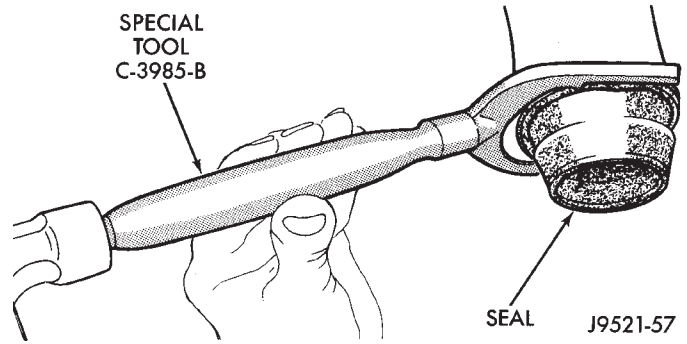


Fig. 18 Removing Overdrive Housing Yoke Seal

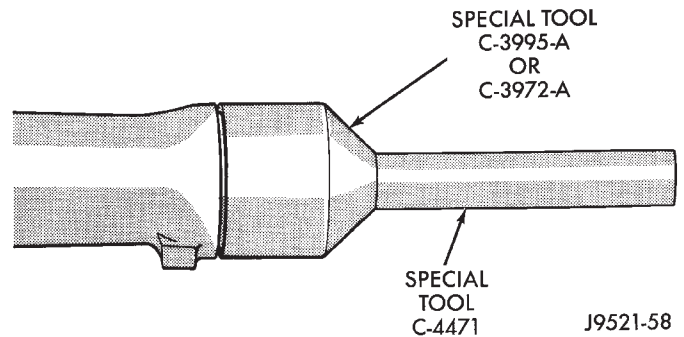


Fig. 19 Installing Overdrive Housing Yoke Seal

SPEEDOMETER ADAPTER

Rear axle gear ratio and tire size determine speedometer pinion requirements.

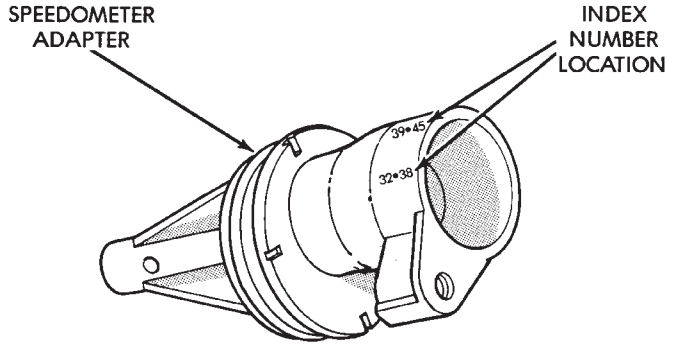
REMOVAL

- (1) Raise vehicle.
- (2) Disconnect wires from vehicle speed sensor.
- (3) Remove adapter clamp and screw (Fig. 20).
- (4) Remove speed sensor and speedometer adapter as assembly.
- (5) Remove speed sensor retaining screw and remove sensor from adapter.
- (6) Remove speedometer pinion from adapter.
- (7) Inspect sensor and adapter O-rings (Fig. 20). Remove and discard O-rings if worn or damaged.
- (8) Inspect terminal pins in speed sensor. Clean pins with Mopar® electrical spray cleaner if dirty or oxidized. Replace sensor if faulty, or pins are loose, severely corroded, or damaged.

REMOVAL AND INSTALLATION (Continued)

INSTALLATION

- (1) Thoroughly clean adapter flange and adapter mounting surface in housing. Surfaces must be clean for proper adapter alignment and speedometer operation.
- (2) Install new O-rings on speed sensor and speedometer adapter if necessary (Fig. 20).
- (3) Lubricate sensor and adapter O-rings with transmission fluid.
- (4) Install vehicle speed sensor in speedometer adapter. Tighten sensor attaching screw to 2-3 N·m (15-27 in. lbs.) torque.
- (5) Install speedometer pinion in adapter.
- (6) Count number of teeth on speedometer pinion. Do this before installing assembly in housing. Then lubricate pinion teeth with transmission fluid.
- (7) Note index numbers on adapter body (Fig. 21). These numbers will correspond to number of teeth on pinion.
- (8) Install speedometer assembly in housing.
- (9) Rotate adapter until required range numbers are at 6 o'clock position. Be sure range index numbers correspond to number of teeth on pinion gear.
- (10) Install speedometer adapter clamp and retaining screw. Tighten clamp screw to 10-12 N·m (90-110 in. lbs.) torque.
- (11) Connect wires to vehicle speed sensor.
- (12) Lower vehicle and top off transmission fluid level, if necessary.



J9321-386

Fig. 21 Index Numbers On Speedometer Pinion Adapter

PARK/NEUTRAL POSITION SWITCH

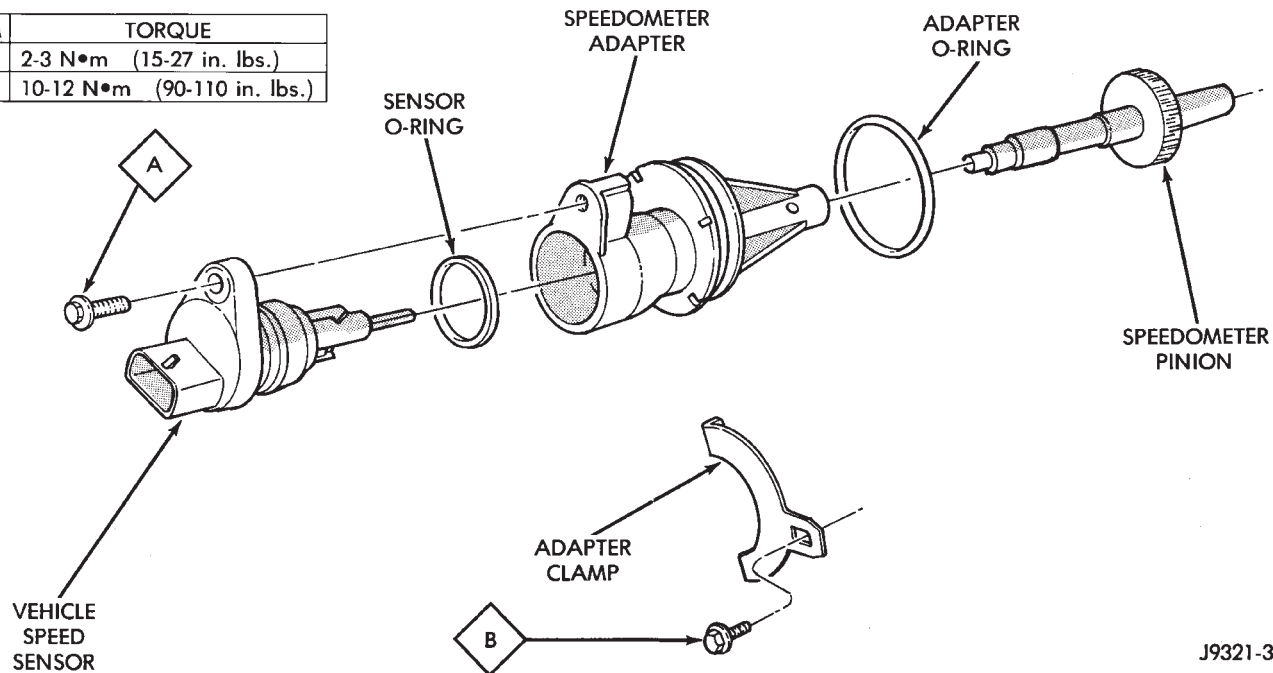
REMOVAL

- (1) Raise vehicle and position drain pan under switch.
- (2) Disconnect switch wires.
- (3) Remove switch from case.

INSTALLATION

- (1) Move shift lever to Park and Neutral positions. Verify that switch operating lever fingers are centered in switch opening in case (Fig. 22).
- (2) Install new seal on switch and install switch in case. Tighten switch to 34 N·m (25 ft. lbs.) torque.

ITEM	TORQUE
A	2-3 N·m (15-27 in. lbs.)
B	10-12 N·m (90-110 in. lbs.)



J9321-385

Fig. 20 Speedometer Pinion Adapter Components

REMOVAL AND INSTALLATION (Continued)

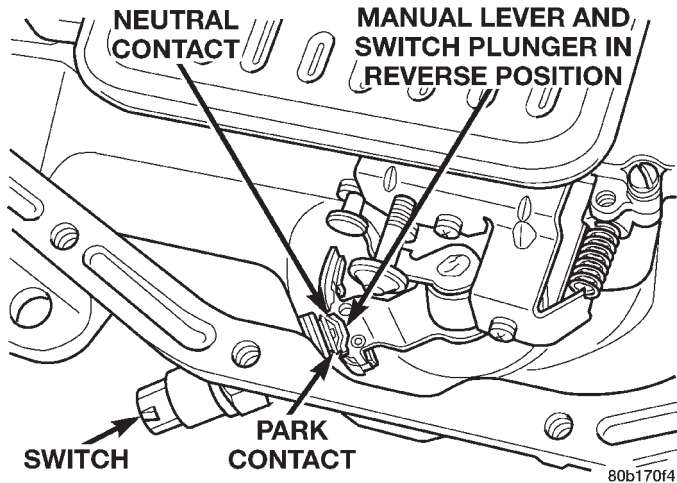


Fig. 22 Park/Neutral Position Switch

- (3) Test continuity of new switch with 12V test lamp.
- (4) Connect switch wires and lower vehicle.
- (5) Top off transmission fluid level.

GEARSHIFT CABLE

REMOVAL

- (1) Shift transmission into Park.
- (2) Remove shift lever bezel and necessary console parts for access to shift lever assembly.
- (3) Disconnect cable at shift lever and feed cable through dash panel opening to underside of vehicle.
- (4) Raise vehicle.
- (5) Disengage cable eyelet at transmission shift lever and pull cable adjuster out of mounting bracket. Then remove old cable from vehicle.

INSTALLATION

- (1) Route cable through hole in dash panel. Fully seat cable grommet into dash panel.
- (2) Place the auto transmission manual shift control lever in "Park" detent (rear-most) position and rotate prop shaft to ensure transmission is in park.
- (3) Connect shift cable to shifter mechanism by snapping cable retaining ears into shifter bracket and press cable end fitting onto lever ball stud.
- (4) Place the floor shifter lever in park position. Ensure that the pawl is seated within the confines of the adjustment gauge clip.
- (5) Snap the cable into the transmission bracket so the retaining ears are engaged and connect cable end fitting onto the manual control lever ball stud.
- (6) Lock shift cable into position by pushing upward on the adjusting lock button.
- (7) Remove and discard the shift cable adjustment gauge clip from the park gate of the shifter.

BRAKE TRANSMISSION SHIFT INTERLOCK

REMOVAL

- (1) Lower the steering column.
- (2) Remove two screws retaining the interlock mechanism to the column (Fig. 23). Unsnap the mechanism from column.

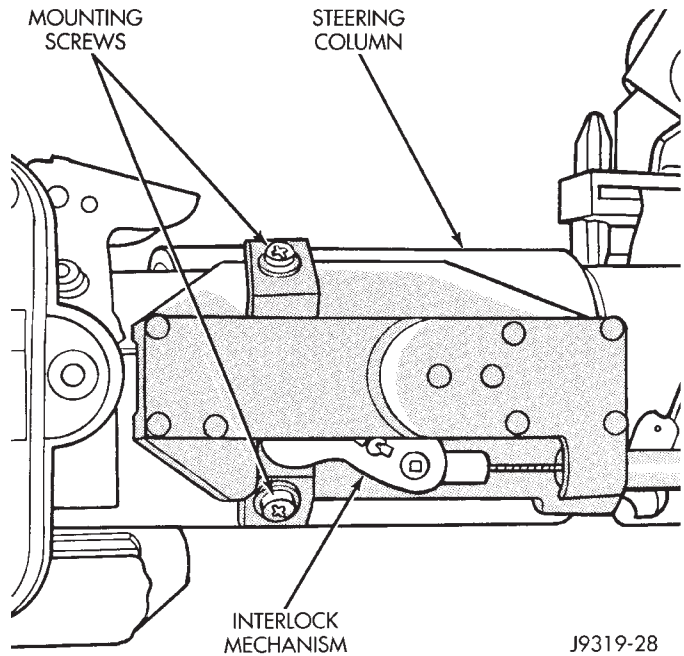


Fig. 23 Interlock Mechanism on Column

- (3) Remove the center console and related trim. Refer to Group 23, Body, for proper procedures.
- (4) Disconnect and remove the cable from the shift bracket.
- (5) Remove the wire connector at the solenoid on the cable
- (6) Remove the accelerator pedal (the cable routes under the pedal). Refer to Group 14, Fuel Systems, for proper procedures.
- (7) Release the cable from the accelerator pedal clip.
- (8) Remove the carpet as necessary to remove the cable.

INSTALLATION

NOTE: The gearshift cable must be secured into position and properly adjusted before the installation of the Brake Transmission Interlock Cable (BTSI).

- (1) Snap the cable base assembly into the large square opening in the steering column.
- (2) Secure the plastic base with two (2) self tapping screws (tighten upper screw first).

REMOVAL AND INSTALLATION (Continued)

- (3) Snap BTSI cable solenoid tie strap into hole in steering column tube.
- (4) Route BTSI cable into two clips on carpet pad.
- (5) Snap electrical connector from brake light switch into BTSI cable solenoid housing.
- (6) Snap BTSI cable adjuster ears into floor shifter bracket and attach cable end fitting onto floor shifter interlock lever stud.
- (7) Remove shipping pin from plastic base. Then place floor shifter in Park position.
- (8) Place the ignition key cylinder in the ACCESSORY position.
- (9) Push the cable adjuster lock clamp downward to lock it.
- (10) Remove and discard the BTSI cable nail head lockpin at steering column.
- (11) Install the center console and related trim. Refer to Group 23, Body, for proper procedures.
- (12) Test the BTSI cable operation.

GOVERNOR SOLENOID AND PRESSURE SENSOR**REMOVAL**

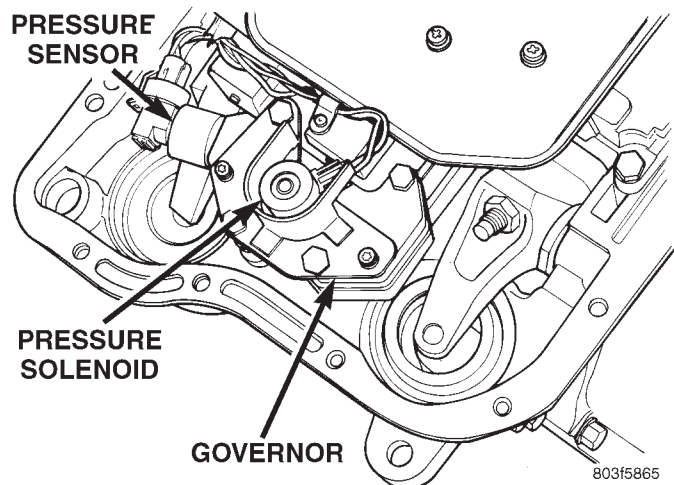
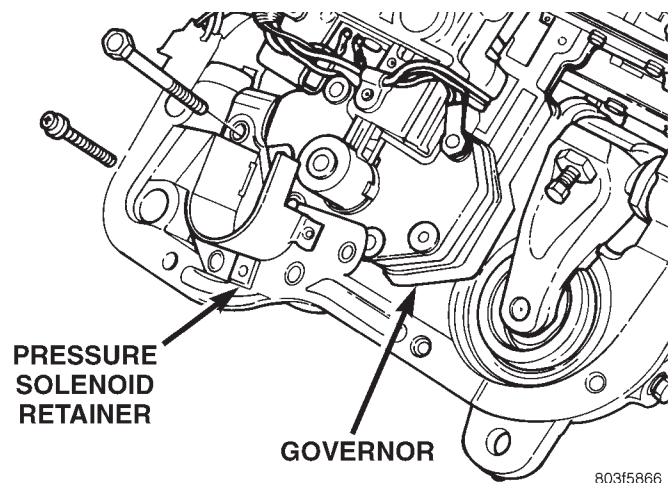
- (1) Hoist and support vehicle on safety stands.
- (2) Remove transmission fluid pan and filter.
- (3) Disengage wire connectors from pressure sensor and solenoid (Fig. 24).
- (4) Remove screws holding pressure solenoid retainer to governor body.
- (5) Separate solenoid retainer from governor (Fig. 25).
- (6) Pull solenoid from governor body (Fig. 26).
- (7) Remove bolts holding governor body to valve body.
- (8) Separate governor body from valve body (Fig. 27).
- (9) Remove governor body gasket.
- (10) Remove retainer holding pressure sensor to governor body.
- (11) Pull pressure sensor from governor body (Fig. 28).

INSTALLATION

Before installing the pressure sensor and solenoid in the governor body, replace O-ring seals, clean the gasket surfaces and replace gasket.

- (1) Lubricate O-ring on pressure sensor with transmission fluid.
- (2) Align pressure sensor to bore in governor body (Fig. 28).
- (3) Push pressure sensor into governor body.
- (4) Install retainer to hold pressure sensor to governor body.
- (5) Place gasket in position on back of governor body (Fig. 27).
- (6) Place governor body in position on valve body.

- (7) Install bolts to hold governor body to valve body.
- (8) Lubricate O-ring, on pressure solenoid, with transmission fluid.
- (9) Align pressure solenoid to bore in governor body (Fig. 26).
- (10) Push solenoid into governor body.
- (11) Place solenoid retainer in position on governor (Fig. 25).
- (12) Install screws to hold pressure solenoid retainer to governor body.
- (13) Engage wire connectors into pressure sensor and solenoid (Fig. 24).
- (14) Install transmission fluid pan and (new) filter.
- (15) Lower vehicle and road test to verify repair.

**Fig. 24 Governor Solenoid And Pressure Sensor****Fig. 25 Pressure Solenoid Retainer****VALVE BODY**

The valve body can be removed for service without having to remove the transmission assembly.

The valve body can be disassembled for cleaning and inspection of the individual components. Refer to

REMOVAL AND INSTALLATION (Continued)

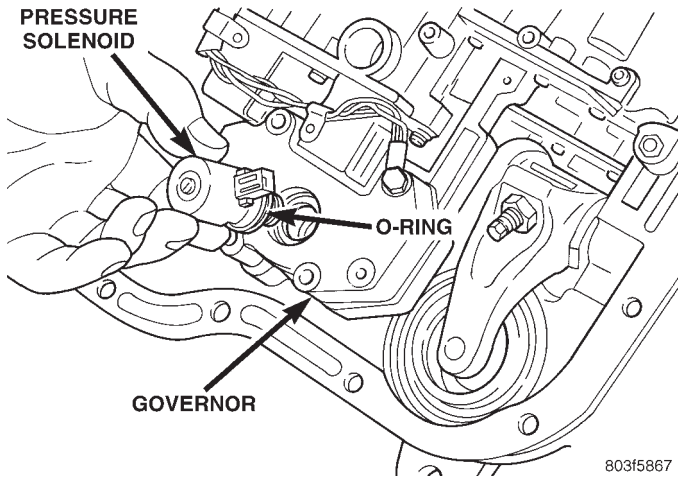


Fig. 26 Pressure Solenoid and O-ring

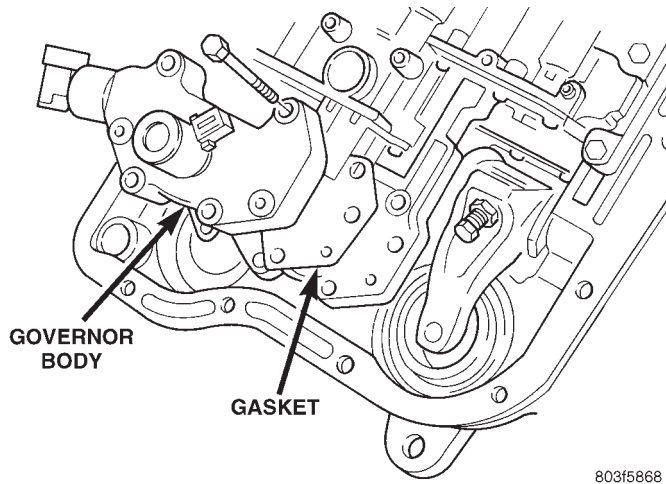


Fig. 27 Governor Body and Gasket

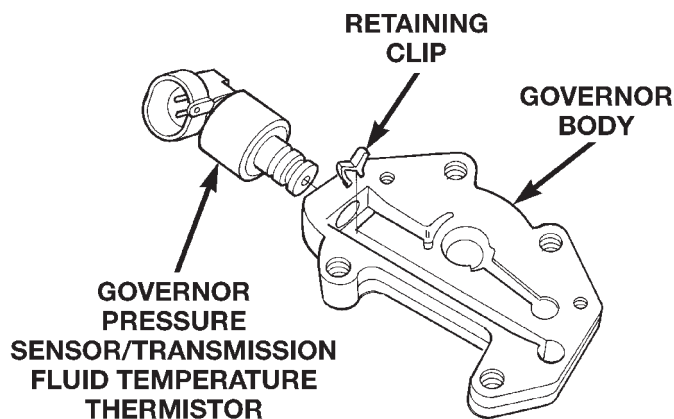


Fig. 28 Pressure Sensor and Retainer

Disassembly and Assembly section for proper procedures.

- The only replaceable valve body components are:
- Manual lever.

- Manual lever washer, seal, E-clip, and shaft seal.
- Manual lever detent ball.
- Throttle lever.
- Fluid filter.
- Pressure adjusting screw bracket.
- Governor pressure solenoid.
- Governor pressure sensor.
- Converter clutch/overdrive solenoid assembly and harness (includes sump temperature thermistor).
- Governor housing gasket.
- Solenoid case connector O-rings.

The remaining valve body components are serviced only as part of a complete valve body assembly.

REMOVAL

- (1) Shift transmission into NEUTRAL.
- (2) Raise vehicle.
- (3) Remove gearshift and throttle levers from shaft of valve body manual lever.
- (4) Disconnect wires at solenoid case connector (Fig. 29).
- (5) Position drain pan under transmission oil pan.
- (6) Remove transmission oil pan and gasket.
- (7) Remove fluid filter from valve body.
- (8) Remove bolts attaching valve body to transmission case.
- (9) Lower valve body enough to remove accumulator piston and springs.
- (10) Work manual lever shaft and electrical connector out of transmission case.
- (11) Lower valve body, rotate valve body away from case, pull park rod out of sprag, and remove valve body (Fig. 30).

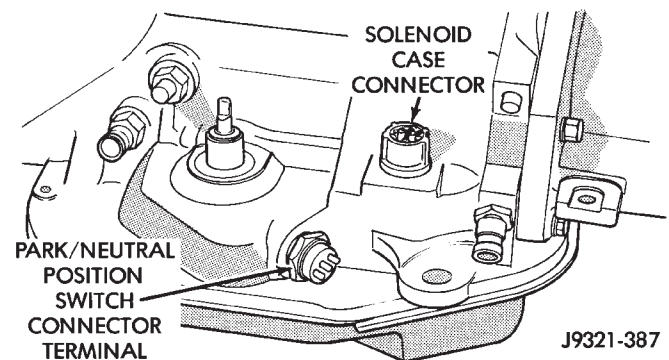


Fig. 29 Transmission Case Connector

INSTALLATION

- (1) Check condition of O-ring seals on valve body harness connector (Fig. 31). Replace seals on connector body if cut or worn.
- (2) Check condition of manual lever shaft seal in transmission case. Replace seal if lip is cut or worn. Install new seal with 15/16 deep well socket (Fig. 32).
- (3) Check condition of seals on accumulator piston (Fig. 33). Install new piston seals, if necessary.

REMOVAL AND INSTALLATION (Continued)

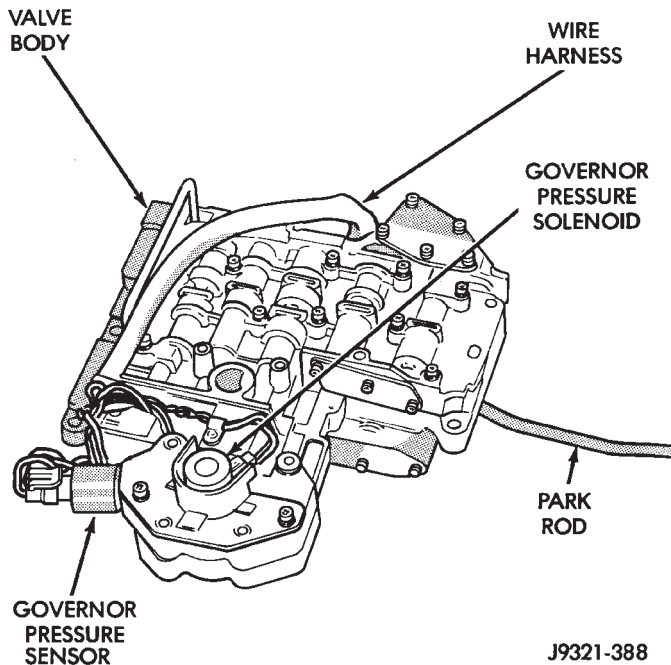


Fig. 30 Valve Body

(4) Place valve body manual lever in low (1 position) so ball on park lock rod will be easier to install in sprag.

(5) Lubricate shaft of manual lever with petroleum jelly. This will ease inserting shaft through seal in case.

(6) Lubricate seal rings on valve body harness connector with petroleum jelly.

(7) Position valve body in case and work end of park lock rod into and through pawl sprag. Turn propeller shaft to align sprag and park lock teeth if necessary. The rod will click as it enters pawl. Move rod to check engagement.

CAUTION: It is possible for the park rod to displace into a cavity just above the pawl sprag during installation. Make sure the rod is actually engaged in the pawl and has not displaced into this cavity.

(8) Install accumulator springs and piston into case. Then swing valve body over piston and outer spring to hold it in place.

(9) Align accumulator piston and outer spring, manual lever shaft and electrical connector in case.

(10) Then seat valve body in case and install one or two bolts to hold valve body in place.

(11) Tighten valve body bolts alternately and evenly to 11 N·m (100 in. lbs.) torque.

(12) Install new fluid filter on valve body. Tighten filter screws to 4 N·m (35 in. lbs.) torque.

(13) Install throttle and gearshift levers on valve body manual lever shaft.

(14) Check and adjust front and rear bands if necessary.

(15) Connect solenoid case connector wires.

(16) Install oil pan and new gasket. Tighten pan bolts to 17 N·m (13 ft. lbs.) torque.

(17) Lower vehicle and fill transmission with Mopar® ATF Plus 3, type 7176 fluid.

(18) Check and adjust gearshift and throttle valve cables, if necessary.

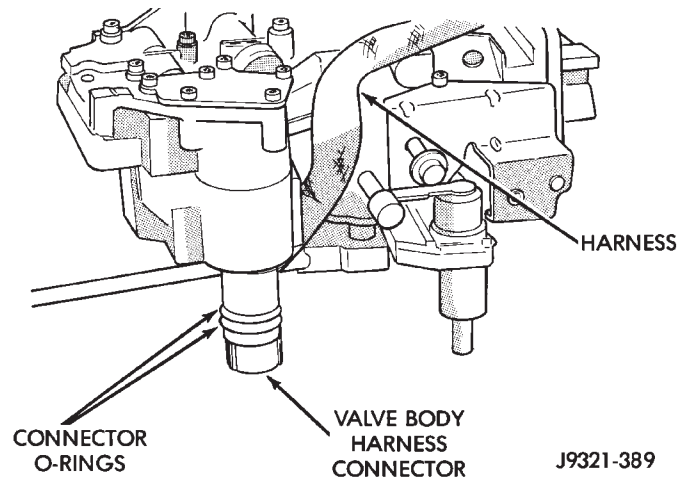


Fig. 31 Valve Body Harness Connector O-Ring Seal

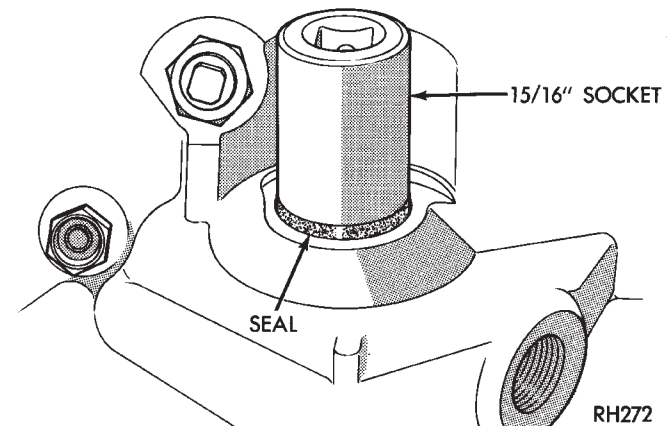


Fig. 32 Manual Lever Shaft Seal

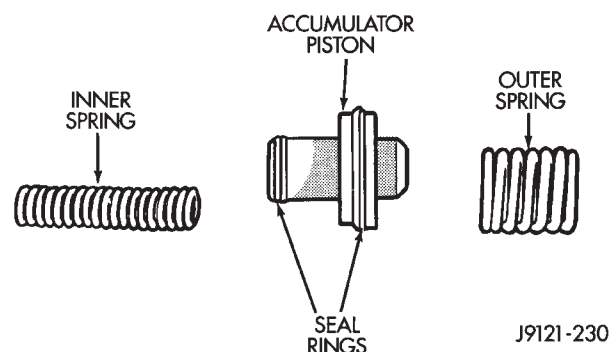


Fig. 33 Accumulator Piston Components

REMOVAL AND INSTALLATION (Continued)

OVERDRIVE UNIT

REMOVAL

- (1) Shift transmission into Park.
- (2) Raise vehicle.
- (3) Mark propeller shaft universal joint(s) and axle pinion yoke for alignment reference at installation.
- (4) Disconnect and remove propeller shaft(s).
- (5) Remove transmission oil pan, remove gasket, drain oil and reinstall pan.
- (6) If overdrive unit had malfunctioned, or if fluid is contaminated, remove entire transmission. If diagnosis indicated overdrive problems only, remove just the overdrive unit.
- (7) Support transmission with transmission jack.
- (8) Remove vehicle speed sensor and speedometer adapter, if necessary.
- (9) Remove bolts attaching overdrive unit to transmission (Fig. 34).

CAUTION: Support the overdrive unit with a jack before moving it rearward. This is necessary to prevent damaging the intermediate shaft. Do not allow the shaft to support the entire weight of the overdrive unit.

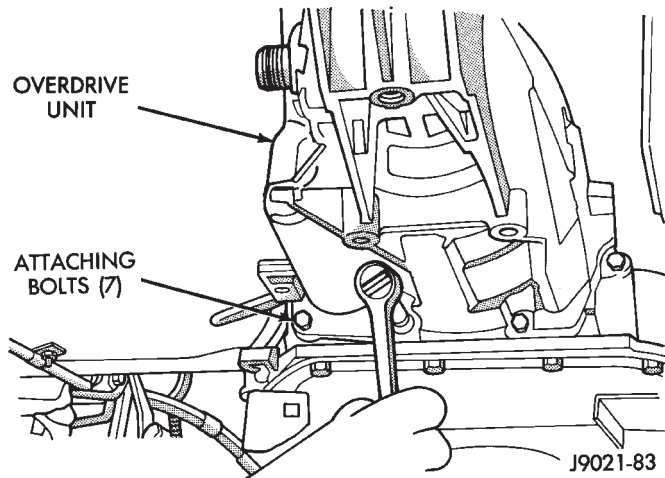


Fig. 34 Overdrive Unit Bolts

- (10) Carefully work overdrive unit off intermediate shaft. Do not tilt unit during removal. Keep it as level as possible.
- (11) If overdrive unit does not require service, immediately insert Alignment Tool 6227-2 in splines of planetary gear and overrunning clutch to prevent splines from rotating out of alignment. If misalign-

ment occurs, overdrive unit will have to be disassembled in order to realign splines.

- (12) Remove and retain overdrive piston thrust bearing. Bearing may remain on piston or in clutch hub during removal.
- (13) Position drain pan on workbench.
- (14) Place overdrive unit over drain pan. Tilt unit to drain residual fluid from case.
- (15) Examine fluid for clutch material or metal fragments. If fluid contains these items, overhaul will be necessary.
- (16) If overdrive unit does not require any service, leave alignment tool in position. Tool will prevent accidental misalignment of planetary gear and overrunning clutch splines.

INSTALLATION

- (1) Be sure overdrive unit Alignment Tool 6227-2 is fully seated before moving unit. If tool is not seated and gear splines rotate out of alignment, overdrive unit will have to be disassembled in order to realign splines.
- (2) If overdrive piston retainer was not removed during service and original case gasket is no longer reusable, prepare new gasket by trimming it.
- (3) Cut out old case gasket around piston retainer with razor knife (Fig. 35).
- (4) Use old gasket as template and trim new gasket to fit.
- (5) Position new gasket over piston retainer and on transmission case. Use petroleum jelly to hold gasket in place if necessary. Do not use any type of sealer to secure gasket. Use petroleum jelly only.

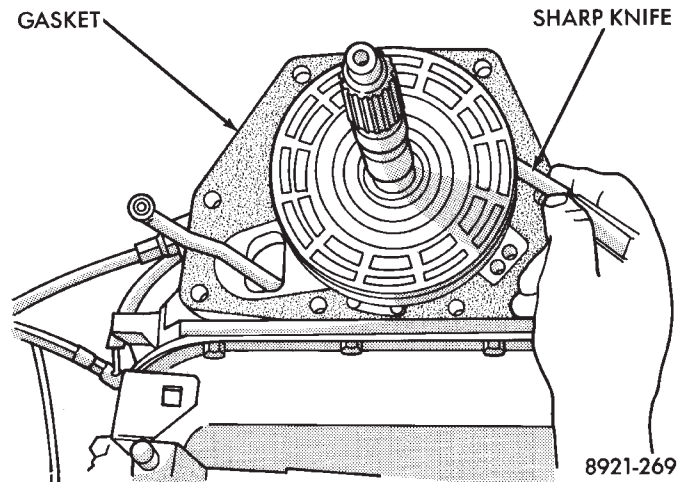


Fig. 35 Trimming Overdrive Case Gasket

REMOVAL AND INSTALLATION (Continued)

(6) Install selective spacer on intermediate shaft, if removed. Spacer goes in groove just rearward of shaft rear splines (Fig. 36).

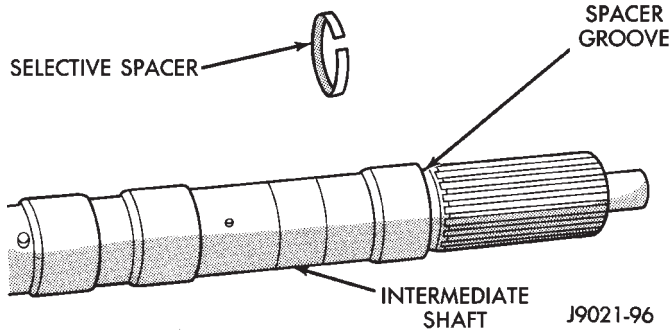


Fig. 36 Intermediate Shaft Selective Spacer Location

(7) Install thrust bearing in overdrive unit sliding hub. Use petroleum jelly to hold bearing in position.

CAUTION: Be sure the shoulder on the inside diameter of the bearing is facing forward.

(8) Verify that splines in overdrive planetary gear and overrunning clutch hub are aligned with Alignment Tool 6227-2. Overdrive unit cannot be installed if splines are not aligned. If splines have rotated out of alignment, unit will have to be disassembled to realign splines.

(9) Carefully slide Alignment Tool 6227-2 out of overdrive planetary gear and overrunning clutch splines.

(10) Raise overdrive unit and carefully slide it straight onto intermediate shaft. Insert park rod into park lock reaction plug at same time. Avoid tilting overdrive during installation as this could cause planetary gear and overrunning clutch splines to rotate out of alignment. If this occurs, it will be necessary to remove and disassemble overdrive unit to realign splines.

(11) Work overdrive unit forward on intermediate shaft until seated against transmission case.

(12) Install bolts attaching overdrive unit to transmission unit. Tighten bolts in diagonal pattern to 34 N·m (25 ft-lbs).

(13) Install speed sensor and speedometer adapter. Be sure to index adapter.

(14) Connect speed sensor and overdrive wires.

(15) Align and install propeller shaft.

OVERDRIVE HOUSING BUSHING

REMOVAL

(1) Remove overdrive housing yoke seal.
 (2) Insert Remover 6957 into overdrive housing. Tighten tool to bushing and remove bushing (Fig. 37).

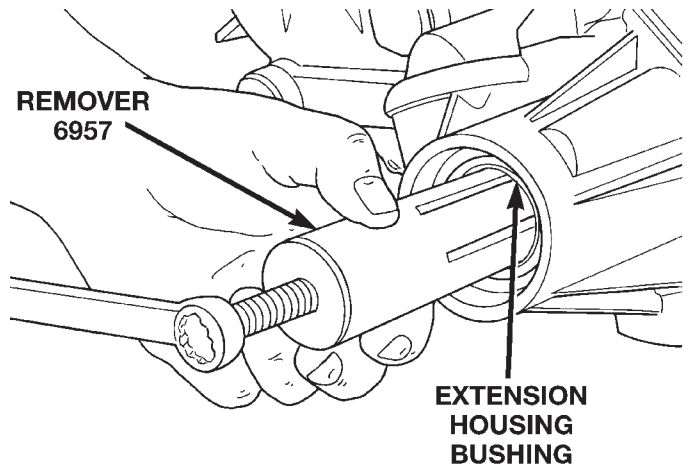


Fig. 37 Bushing Removal—Typical

INSTALLATION

(1) Align bushing oil hole with oil slot in overdrive housing.

(2) Tap bushing into place with Installer 6951 and Handle C-4171.

(3) Install new oil seal in housing using Seal Installer C-3995-A (Fig. 38).

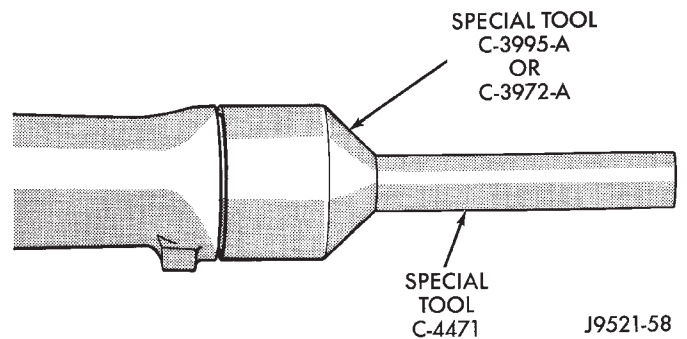


Fig. 38 Overdrive Housing Seal Installation

REMOVAL AND INSTALLATION (Continued)

OUTPUT SHAFT REAR BEARING

REMOVAL

- (1) Remove overdrive unit from the vehicle.
- (2) Remove overdrive geartrain from housing.
- (3) Remove snap ring holding output shaft rear bearing into overdrive housing (Fig. 39).
- (4) Using a suitable driver inserted through the rear end of housing, drive bearing from housing.

INSTALLATION

- (1) Place replacement bearing in position in housing.
- (2) Using a suitable driver, drive bearing into housing until the snap ring groove is visible.
- (3) Install snap ring to hold bearing into housing (Fig. 39).
- (4) Install overdrive geartrain into housing.
- (5) Install overdrive unit in vehicle.

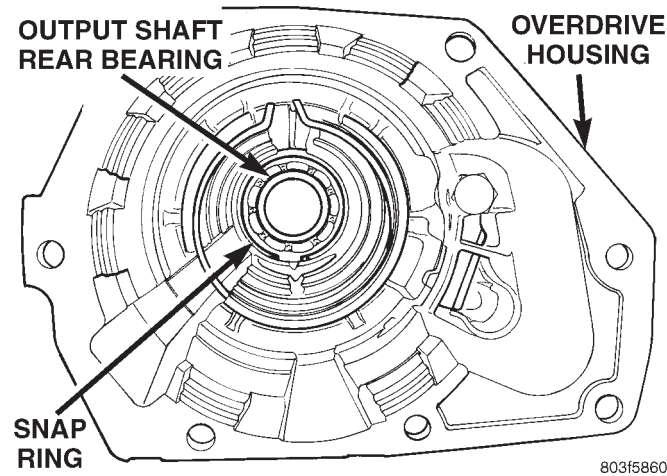


Fig. 39 Output Shaft Rear Bearing

OUTPUT SHAFT FRONT BEARING

REMOVAL

- (1) Remove overdrive unit from the vehicle.
- (2) Remove overdrive geartrain from housing.
- (3) Remove snap ring holding output shaft front bearing to overdrive geartrain. (Fig. 40).
- (4) Pull bearing from output shaft.

INSTALLATION

- (1) Place replacement bearing in position on geartrain with locating retainer groove toward the rear.
- (2) Push bearing onto shaft until the snap ring groove is visible.
- (3) Install snap ring to hold bearing onto output shaft (Fig. 40).
- (4) Install overdrive geartrain into housing.
- (5) Install overdrive unit in vehicle.

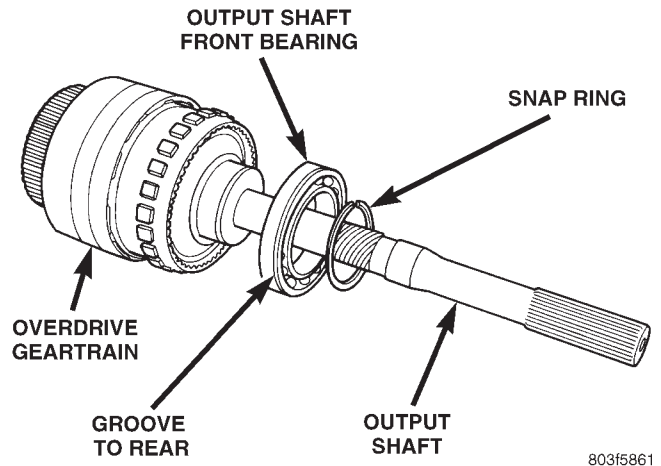


Fig. 40 Output Shaft Front Bearing

DISASSEMBLY AND ASSEMBLY

VALVE BODY

Remove the valve body from the transmission, refer to Removal and Installation procedures section in this group.

DISASSEMBLY

CAUTION: Do not clamp any valve body component in a vise. This practice can damage the component resulting in unsatisfactory operation after assembly and installation. Do not use pliers to remove any of the valves, plugs or springs and do not force any of the components out or into place. The valves and valve body housings will be damaged if force is used. Tag or mark the valve body springs for reference as they are removed. Do not allow them to become intermixed.

- (1) Remove fluid filter.
- (2) Disconnect wires from governor pressure sensor and solenoid (Fig. 41).
- (3) Remove screws attaching governor body and retainer plate to transfer plate (Fig. 42).
- (4) Remove retainer plate, governor body and gasket from transfer plate (Fig. 43).
- (5) Disconnect wires from governor pressure sensor, if not done previously.
- (6) Remove governor pressure sensor from governor body. Sensor is retained in body with M-shaped spring clip (Fig. 44). Remove clip with small pointed tool and slide sensor out of body.
- (7) Remove governor pressure solenoid by pulling it straight out of bore in governor body (Fig. 45). Remove and discard solenoid O-rings if worn, cut, or torn.

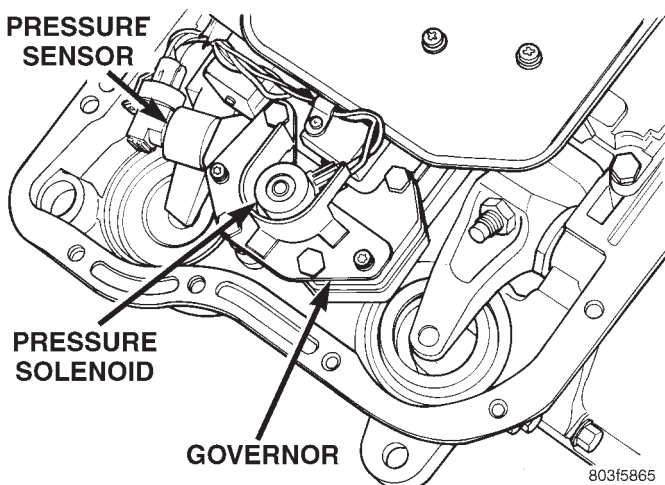


Fig. 41 Governor Pressure Solenoid And Sensor Wire Locations

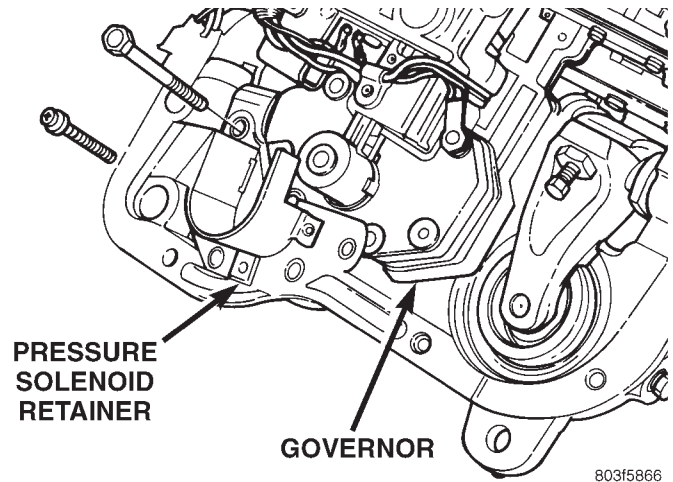


Fig. 42 Governor Body And Retainer Plate Attaching Screw

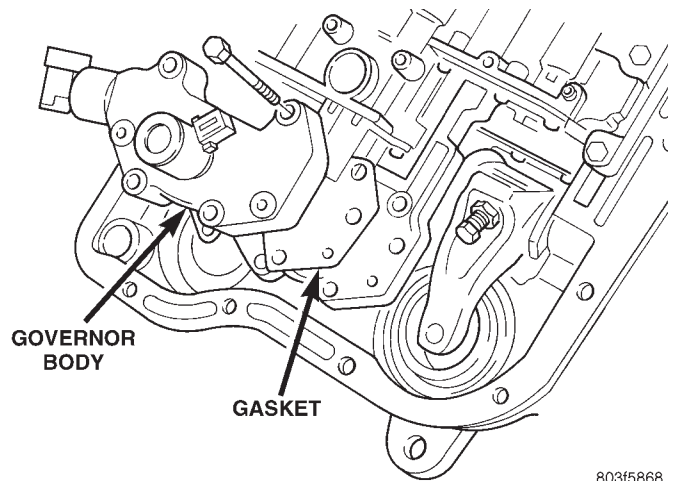


Fig. 43 Governor Body And Gasket

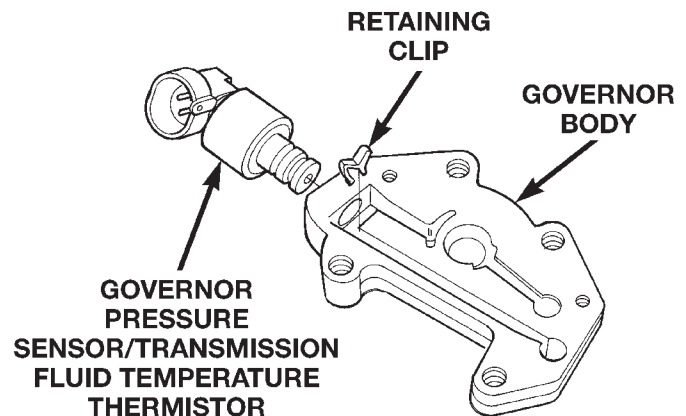


Fig. 44 Governor Pressure Sensor

DISASSEMBLY AND ASSEMBLY (Continued)

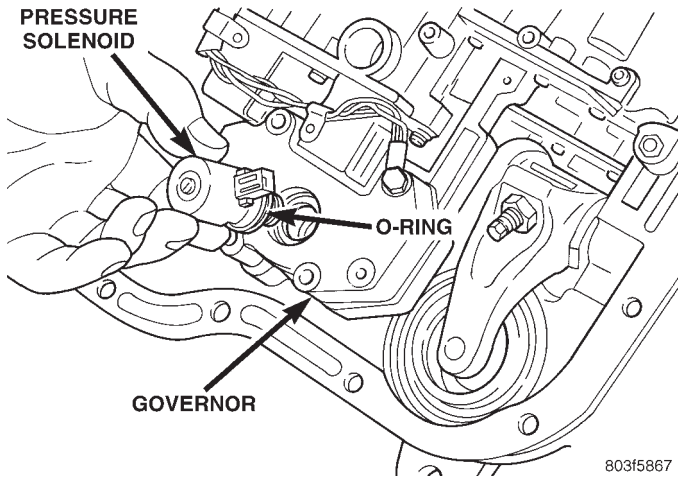


Fig. 45 Governor Pressure Solenoid

- (8) Remove transmission fluid filter.
- (9) Remove small shoulder bolt that secures solenoid harness case connector to 3-4 accumulator housing (Fig. 46). **Retain shoulder bolt. Either tape it to harness or thread it back into accumulator housing after connector removal.**
- (10) Unhook overdrive/converter solenoid harness from 3-4 accumulator cover plate (Fig. 47).
- (11) Turn valve body over and remove screws that attach overdrive/converter solenoid assembly to valve body (Fig. 48).
- (12) Remove solenoid and harness assembly from valve body (Fig. 49).
- (13) Remove boost valve cover (Fig. 50).
- (14) Remove boost valve retainer, valve spring and boost valve (Fig. 51).

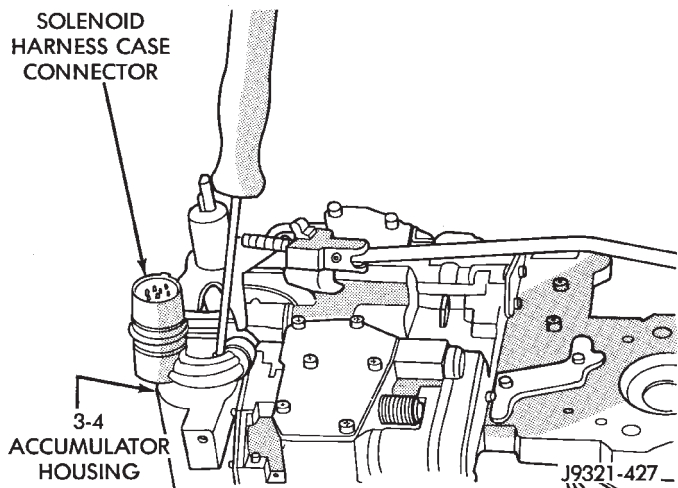


Fig. 46 Solenoid Harness Case Connector Shoulder Bolt

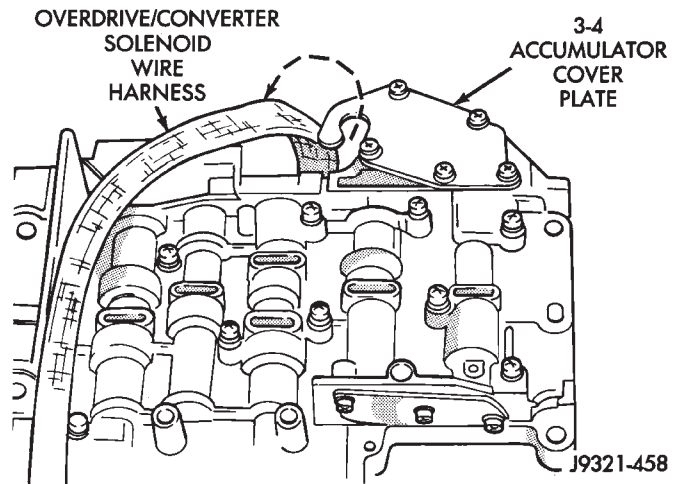


Fig. 47 Unhooking Solenoid Harness From Accumulator Cover Plate

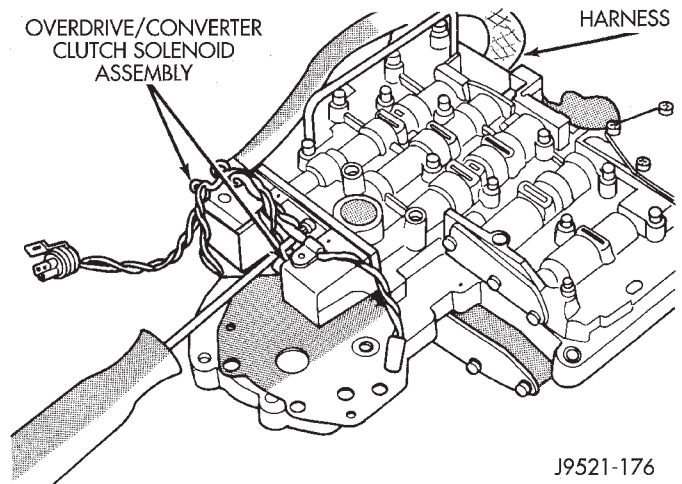


Fig. 48 Solenoid Assembly Screws

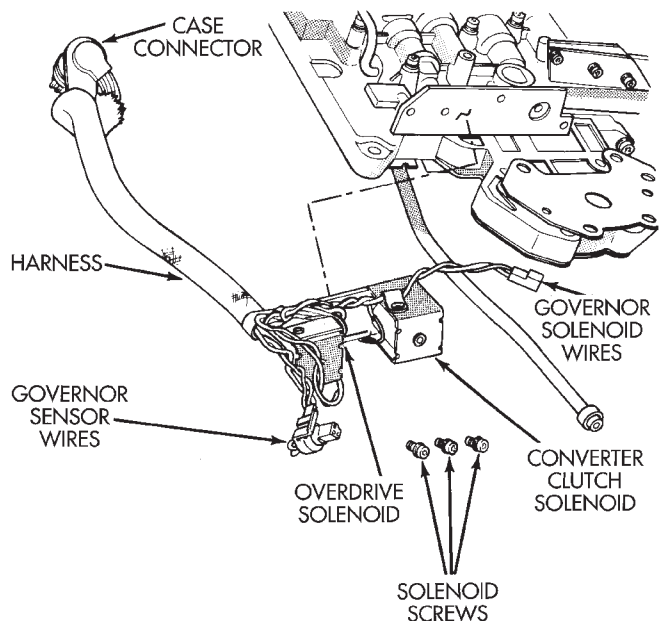


Fig. 49 Solenoid Assembly

DISASSEMBLY AND ASSEMBLY (Continued)

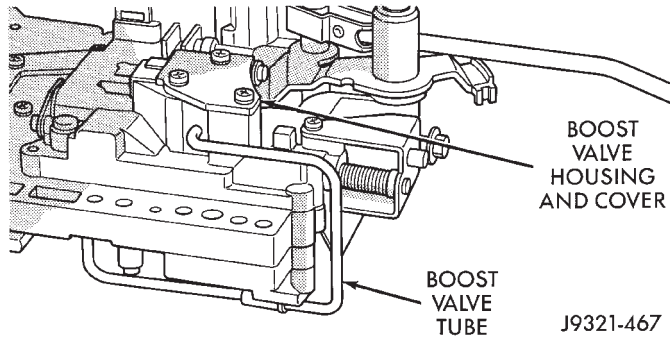


Fig. 50 Boost Valve Cover Location

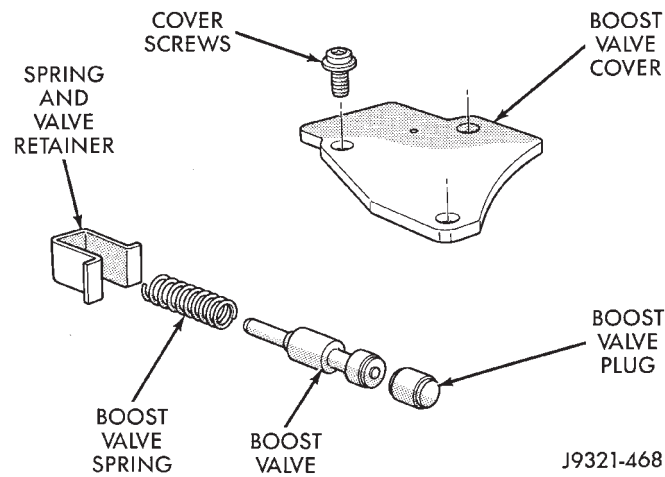


Fig. 51 Boost Valve Components

(15) Secure detent ball and spring with Retainer Tool 6583 (Fig. 52).

(16) Remove park rod E-clip and separate rod from manual lever (Fig. 53).

(17) Remove E-clip and washer that retains throttle lever shaft in manual lever (Fig. 54).

(18) Remove manual lever and throttle lever (Fig. 55). Rotate and lift manual lever off valve body and throttle lever shaft. Then slide throttle lever out of valve body.

(19) Position pencil magnet next to detent housing to catch detent ball and spring. Then carefully

remove Retainer Tool 6583 and remove detent ball and spring (Fig. 56).

(20) Remove screws attaching pressure adjusting screw bracket to valve body and transfer plate (Fig. 57). Hold bracket firmly against spring tension while removing last screw.

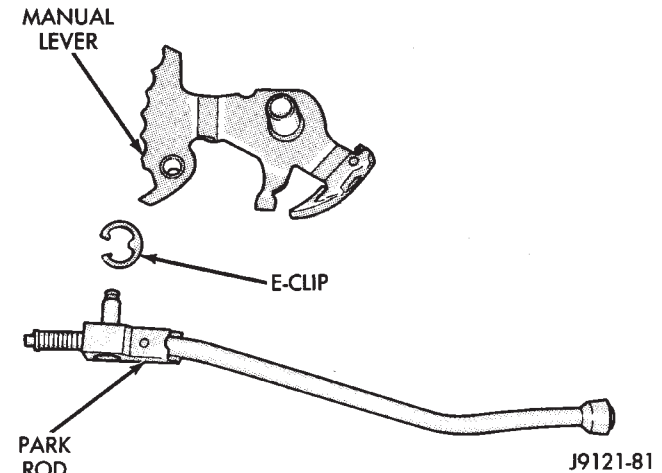


Fig. 53 Park Rod

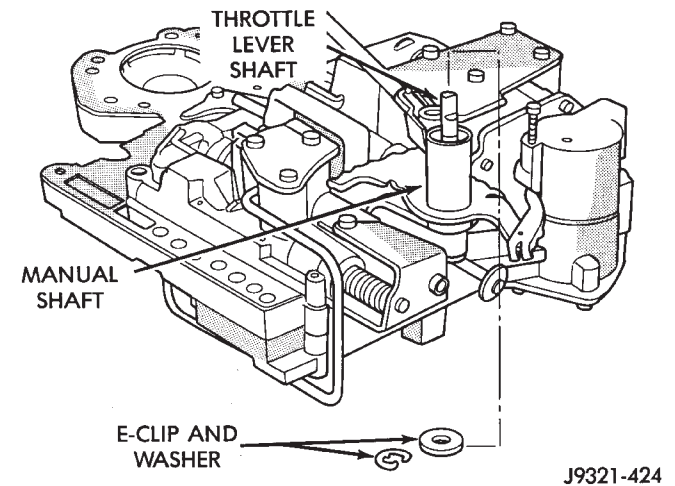


Fig. 54 Throttle Lever E-Clip And Washer

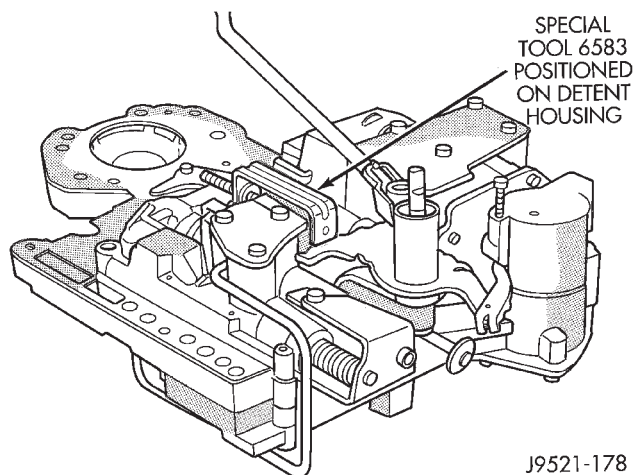


Fig. 52 Detent Ball And Spring

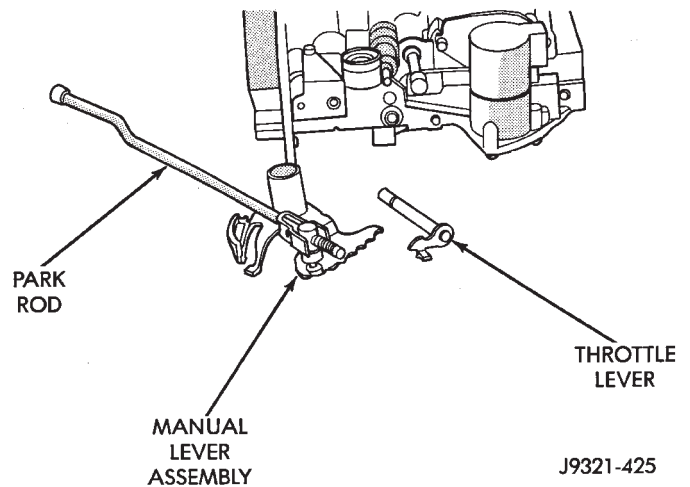


Fig. 55 Manual And Throttle Lever

DISASSEMBLY AND ASSEMBLY (Continued)

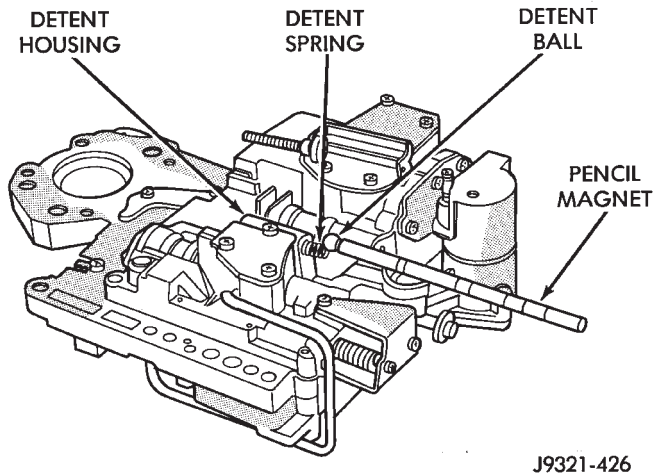


Fig. 56 Detent Ball And Spring

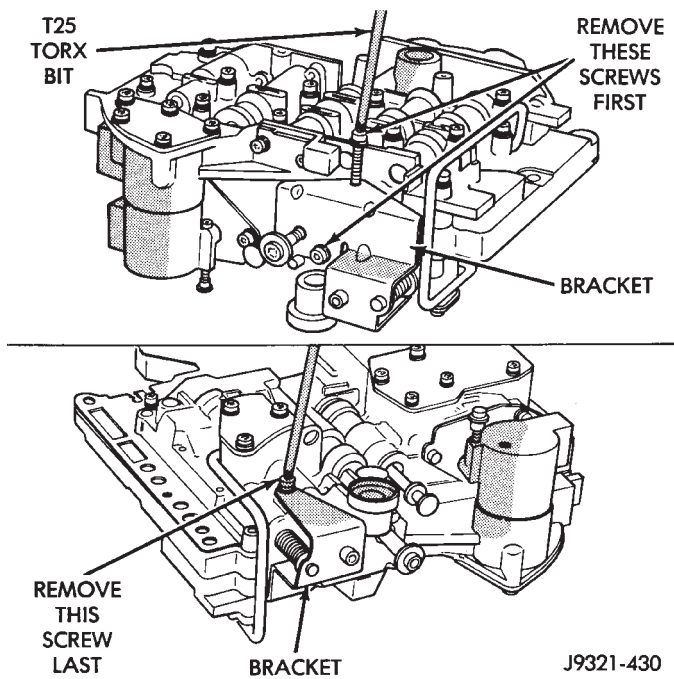


Fig. 57 Adjusting Screw Bracket Fastener

(21) Remove adjusting screw bracket, line pressure adjusting screw, pressure regulator valve spring and switch valve spring (Fig. 58). **Do not remove throttle pressure adjusting screw from bracket and do not disturb setting of either adjusting screw during removal.**

(22) Turn upper housing over and remove switch valve, regulator valve and spring, and manual valve (Fig. 59).

(23) Remove kickdown detent, kickdown valve, and throttle valve and spring (Fig. 59).

(24) Loosen left-side 3-4 accumulator housing attaching screw about 2-3 threads. Then remove center and right-side housing attaching screws (Fig. 60).

(25) Carefully rotate 3-4 accumulator housing upward and remove 3-4 shift valve spring and converter clutch valve plug and spring (Fig. 61).

(26) Remove left-side screw and remove 3-4 accumulator housing from valve body (Fig. 62).

(27) Bend back tabs on boost valve tube brace (Fig. 63).

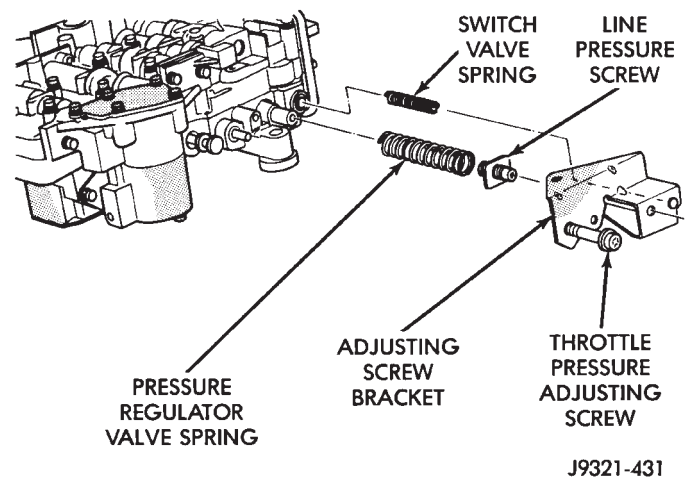


Fig. 58 Adjusting Screw Bracket And Spring

DISASSEMBLY AND ASSEMBLY (Continued)

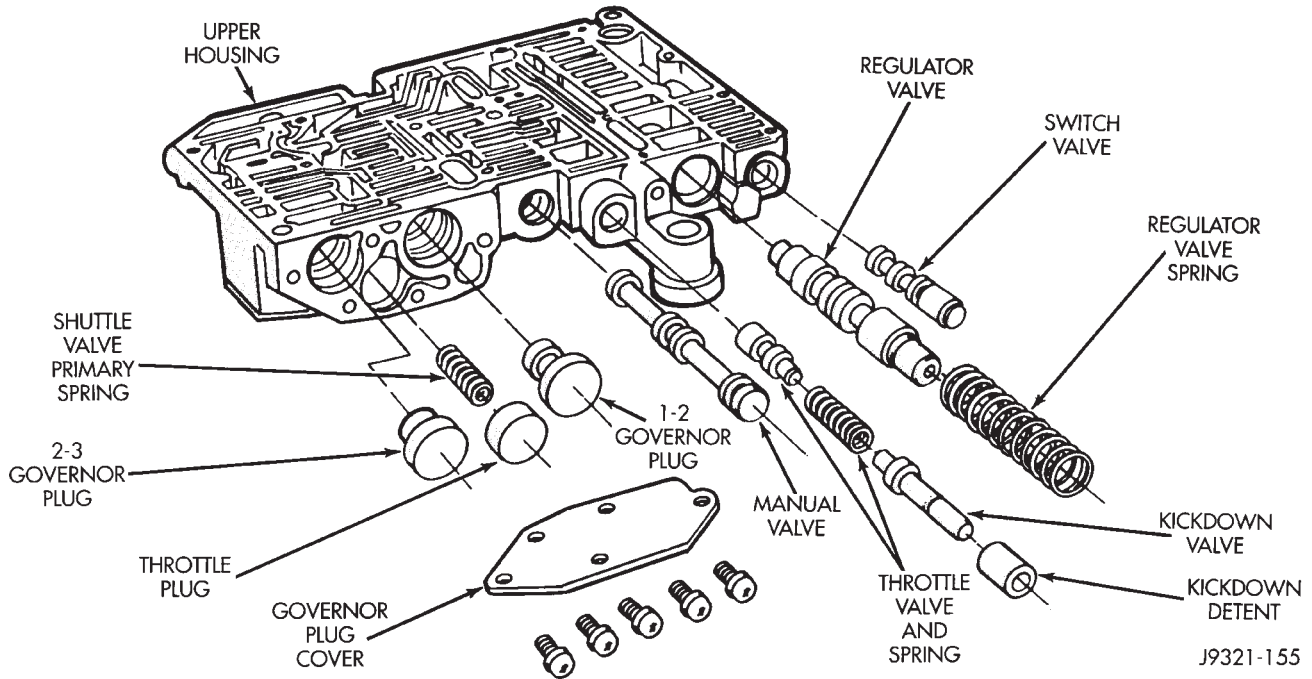


Fig. 59 Upper Housing Control Valve Locations

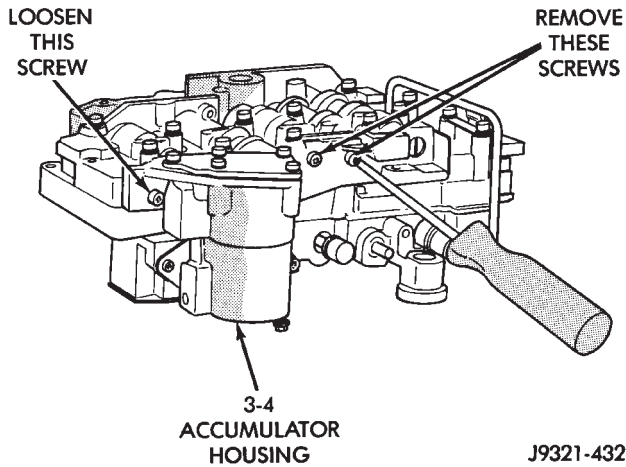


Fig. 60 Accumulator Housing Screw Locations

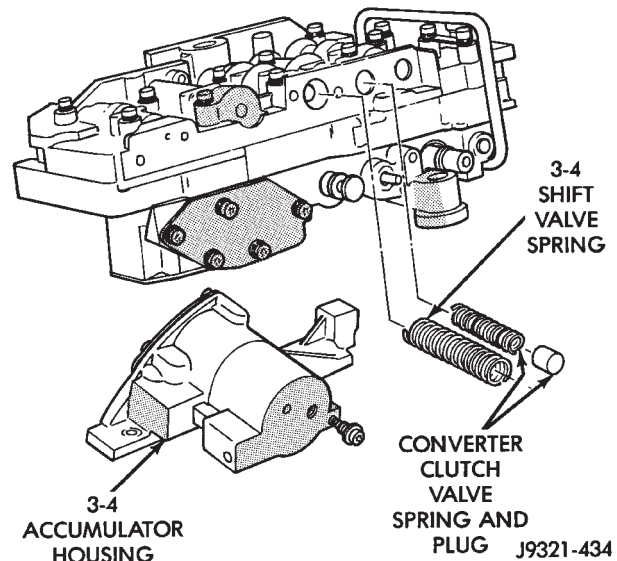


Fig. 62 Accumulator Housing, Valve Springs And Plug

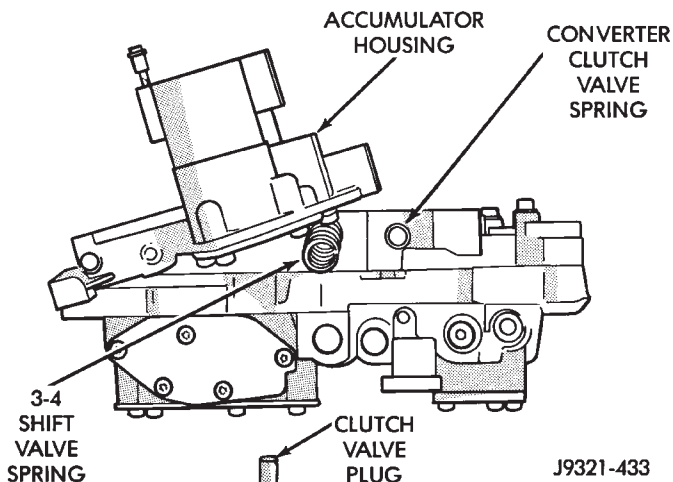


Fig. 61 3-4 Shift And Converter Clutch Valve Springs And Plug

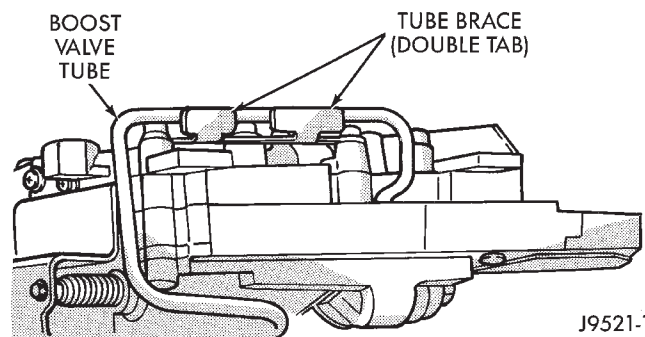


Fig. 63 Boost Valve Tube Brace

DISASSEMBLY AND ASSEMBLY (Continued)

(28) Remove boost valve connecting tube (Fig. 64). Disengage tube from upper housing port first. Then rock opposite end of tube back and forth to work it out of lower housing.

CAUTION: Do not use tools to loosen or pry the connecting tube out of the valve body housings. Loosen and remove the tube by hand only.

(29) Turn valve body over so lower housing is facing upward (Fig. 65). In this position, the two check balls in upper housing will remain in place and not fall out when lower housing and separator plate are removed.

(30) Remove screws attaching valve body lower housing to upper housing and transfer plate (Fig. 65). **Note position of boost valve tube brace for assembly reference.**

(31) Remove lower housing and overdrive separator plate from transfer plate (Fig. 65).

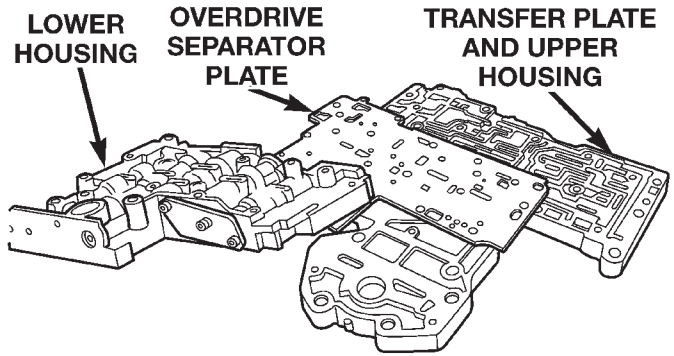
(32) Remove the ECE check ball from the transfer plate (Fig. 66). The ECE check ball is approximately 4.8 mm (3/16 in.) in diameter.

(33) Remove transfer plate from upper housing (Fig. 67).

(34) Turn transfer plate over so upper housing separator plate is facing upward.

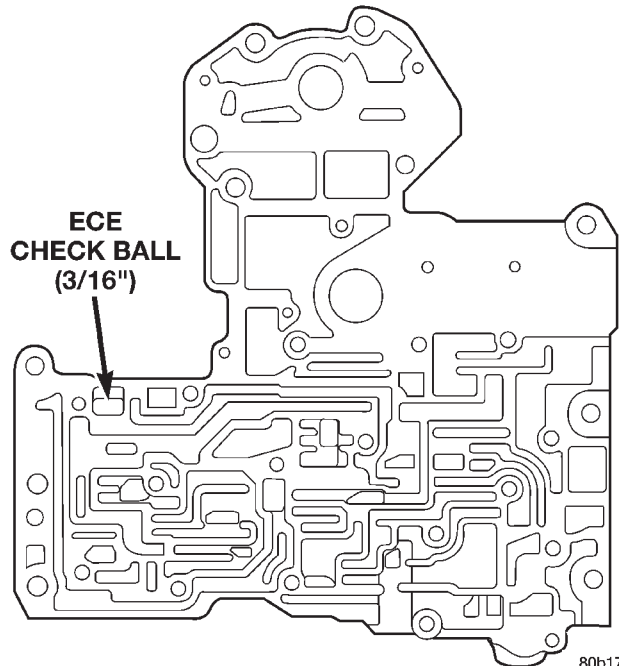
(35) Remove upper housing separator plate from transfer plate (Fig. 68). Note position of filter in separator plate for assembly reference.

(36) Remove rear clutch and rear servo check balls from transfer plate. Note check ball location for assembly reference (Fig. 69).



80b170f8

Fig. 65 Lower Housing



80b17125

Fig. 66 ECE Check Ball

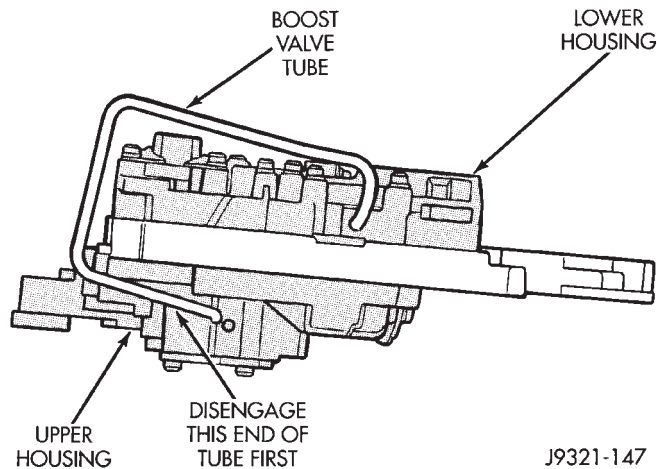
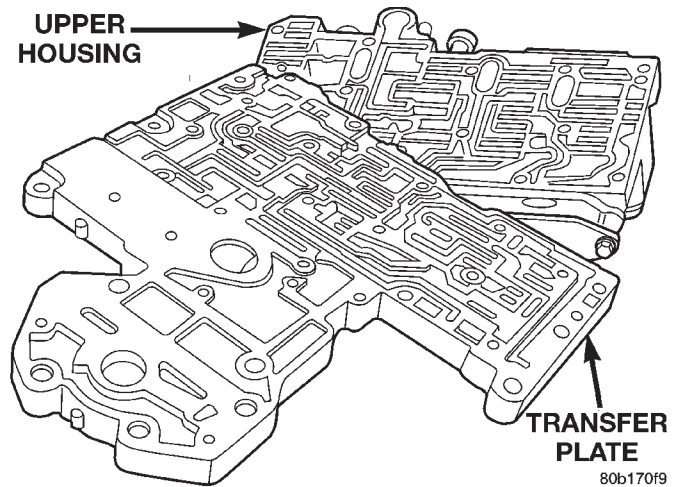
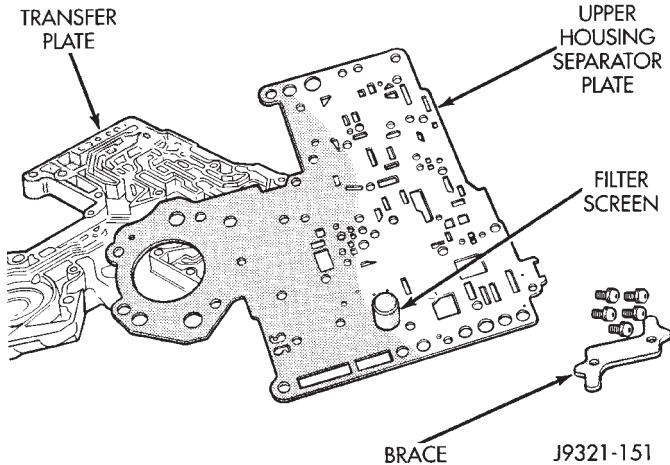
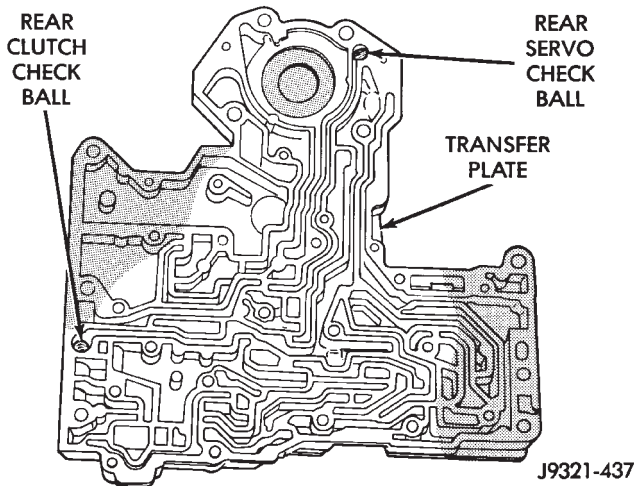


Fig. 64 Boost Valve Tube



80b170f9

Fig. 67 Transfer Plate

DISASSEMBLY AND ASSEMBLY (Continued)**Fig. 68 Upper Housing Separator Plate****Fig. 69 Rear Clutch And Rear Servo Check Ball Locations****VALVE BODY UPPER HOUSING**

(1) Note location of check balls in valve body upper housing (Fig. 70). Then remove the one large diameter and the six smaller diameter check balls.

(2) Remove governor plug and shuttle valve covers (Fig. 72).

(3) Remove E-clip that secures shuttle valve secondary spring on valve stem (Fig. 71).

(4) Remove throttle plug, primary spring, shuttle valve, secondary spring, and spring guides (Fig. 72).

(5) Remove boost valve retainer, spring and valve if not previously removed.

(6) Remove throttle plug and 1-2 and 2-3 governor plugs (Fig. 59).

(7) Turn upper housing around and remove limit valve and shift valve covers (Fig. 73).

(8) Remove limit valve housing. Then remove retainer, spring, limit valve, and 2-3 throttle plug from limit valve housing (Fig. 73).

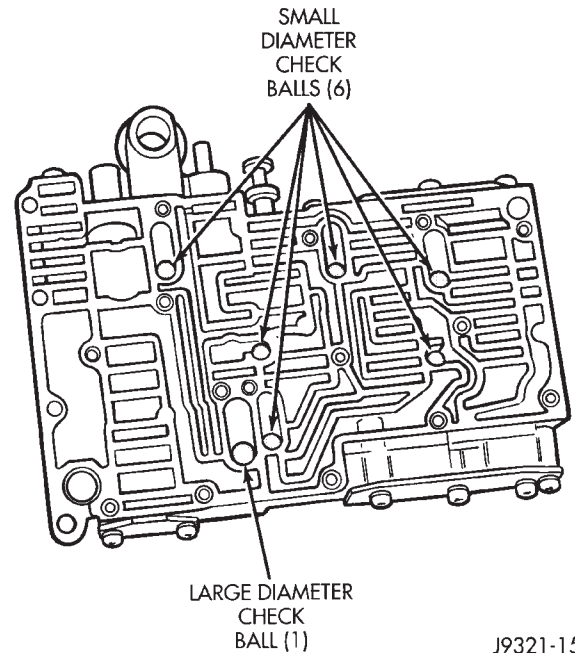
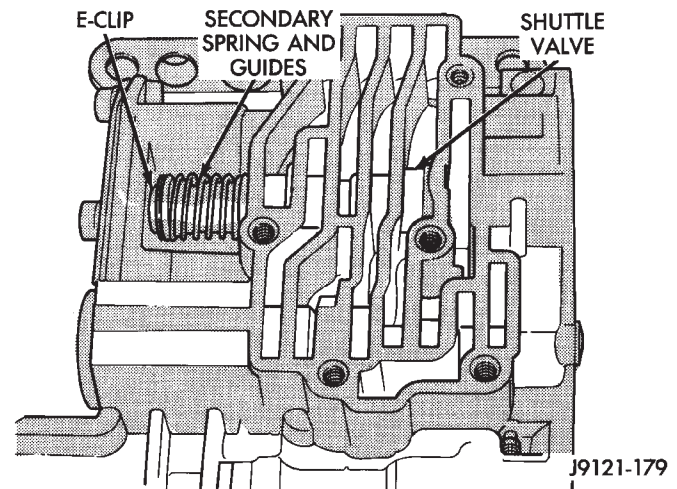
(9) Remove 1-2 shift control valve and spring (Fig. 73).

(10) Remove 1-2 shift valve and spring (Fig. 73).

(11) Remove 2-3 shift valve and spring from valve body (Fig. 73).

(12) Remove pressure plug cover (Fig. 73).

(13) Remove line pressure plug, sleeve, throttle pressure plug and spring (Fig. 73).

**Fig. 70 Check Ball Locations In Upper Housing****Fig. 71 Shuttle Valve E-Clip And Secondary Spring Location**

DISASSEMBLY AND ASSEMBLY (Continued)

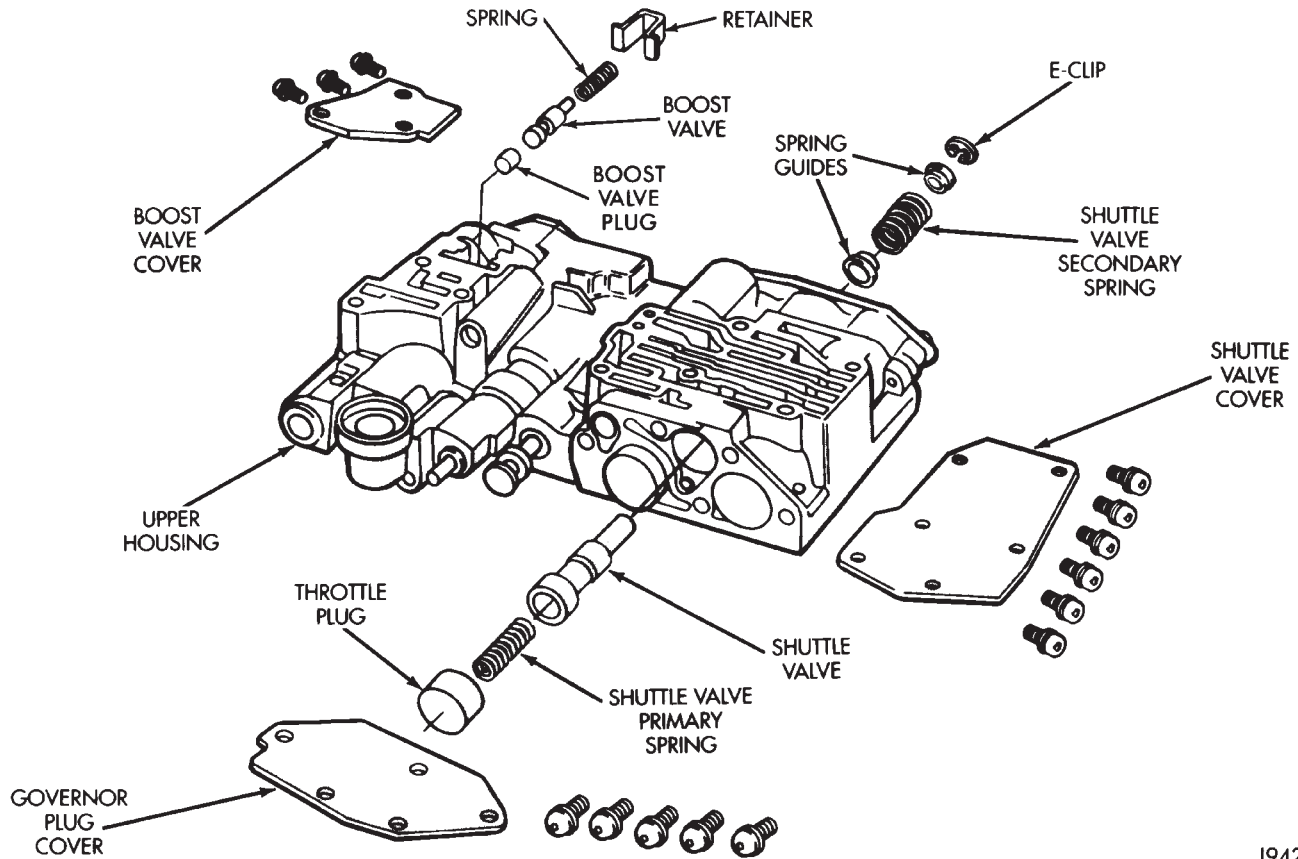


Fig. 72 Shuttle And Boost Valve Components

J9421-217

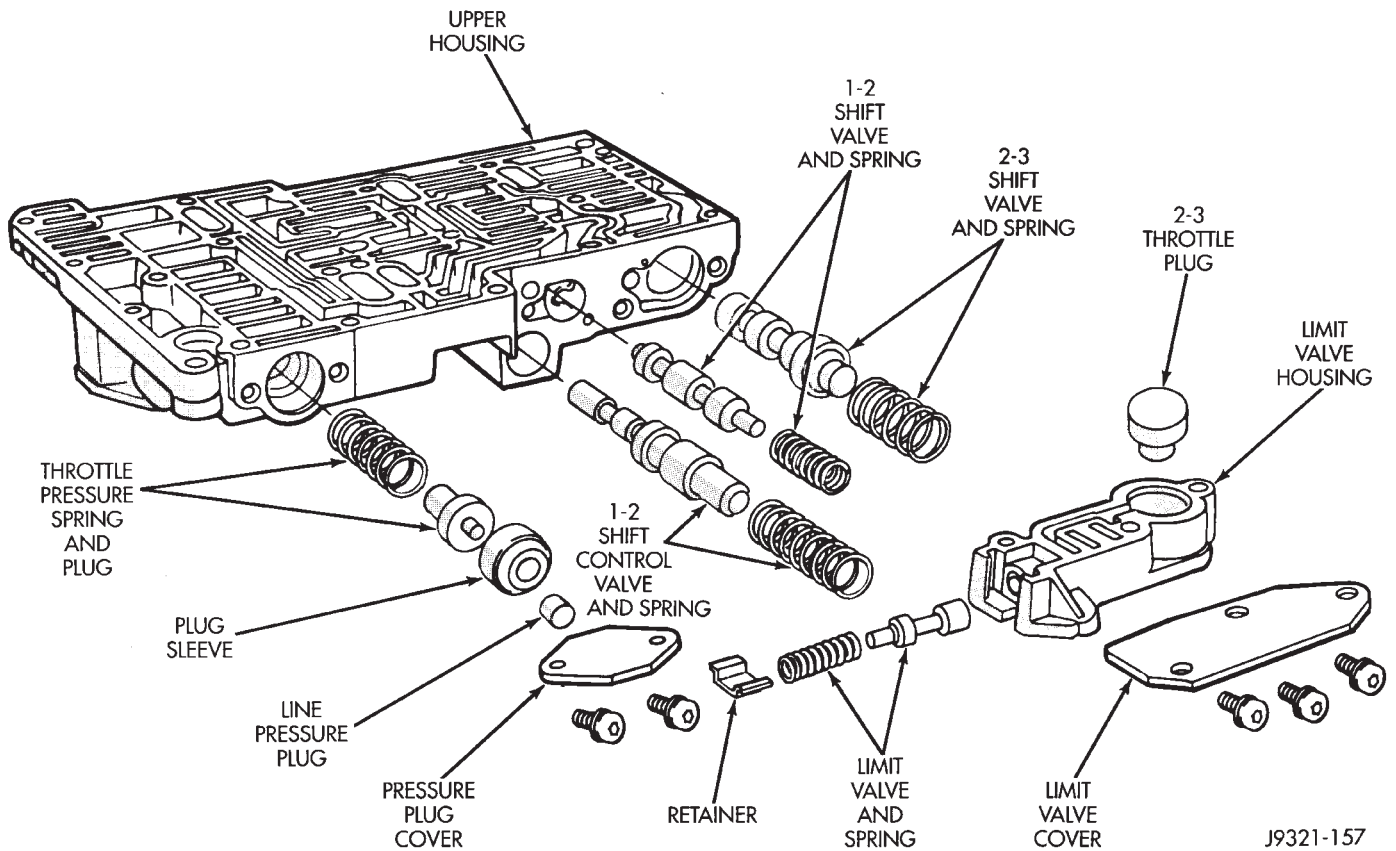


Fig. 73 Upper Housing Shift Valve And Pressure Plug Locations

J9321-157

DISASSEMBLY AND ASSEMBLY (Continued)

VALVE BODY LOWER HOUSING

- (1) Remove timing valve cover.
- (2) Remove 3-4 timing valve and spring.
- (3) Remove 3-4 quick fill valve, spring and plug.
- (4) Remove 3-4 shift valve and spring.
- (5) Remove converter clutch valve, spring and plug (Fig. 74).
- (6) Remove converter clutch timing valve, retainer and valve spring.

3-4 ACCUMULATOR HOUSING

- (1) Remove end plate from housing.
- (2) Remove piston spring.
- (3) Remove piston. Remove and discard piston seals (Fig. 75).

ASSEMBLY

CAUTION: Do not force valves or plugs into place during reassembly. If the valve body bores, valves and plugs are free of distortion or burrs, the valve body components should all slide into place easily. In addition, do not overtighten the transfer plate and valve body screws during reassembly. Overtightening can distort the housings resulting in valve sticking, cross leakage and unsatisfactory operation. Tighten valve body screws to recommended torque only.

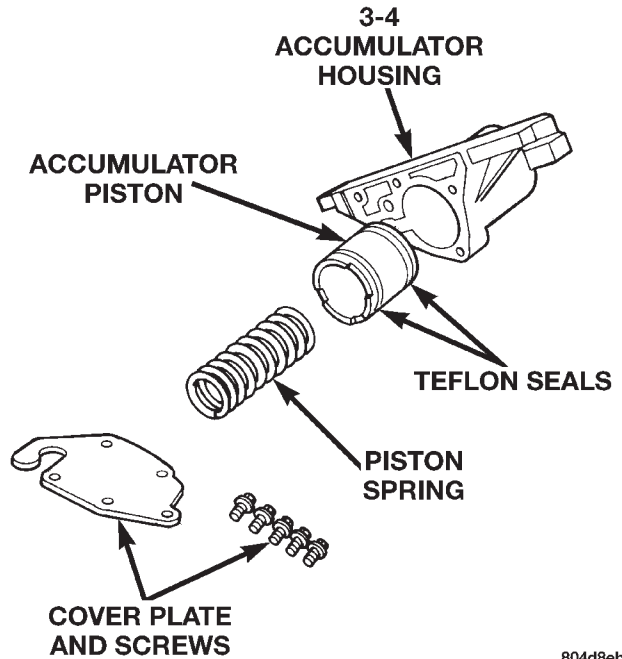


Fig. 75 Accumulator Housing Components

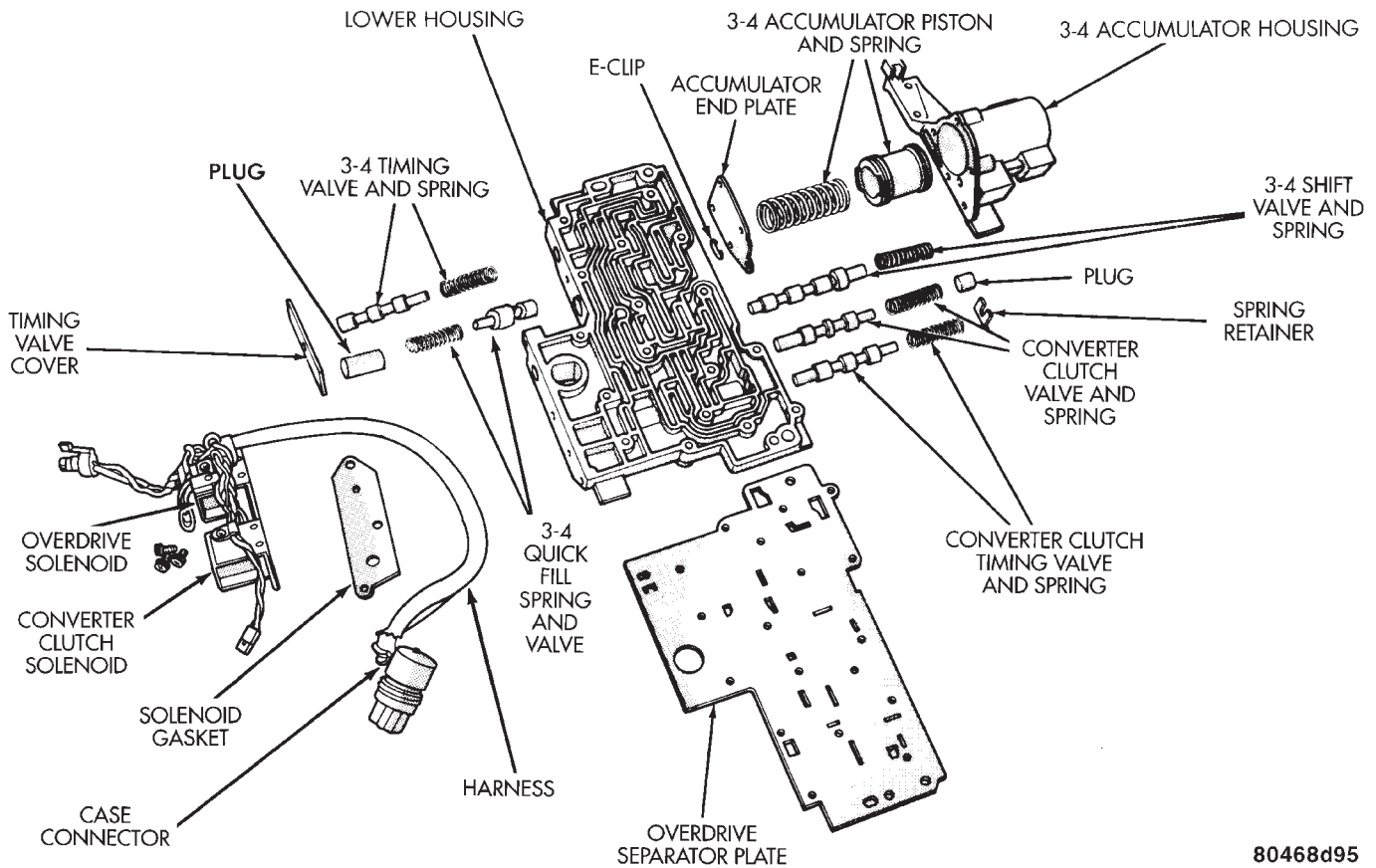


Fig. 74 Lower Housing Shift Valves And Springs

DISASSEMBLY AND ASSEMBLY (Continued)

LOWER HOUSING

- (1) Lubricate valves, springs, and the housing valve and plug bores with clean transmission fluid (Fig. 74).
- (2) Install 3-4 timing valve spring and valve in lower housing.
- (3) Install 3-4 quick fill valve in lower housing.
- (4) Install 3-4 quick fill valve spring and plug in housing.
- (5) Install timing valve end plate. Tighten end plate screws to 4 N·m (35 in. lbs.) torque.

3-4 ACCUMULATOR

- (1) Lubricate accumulator piston, seals and housing piston bore with clean transmission fluid (Fig. 75).
- (2) Install new seal rings on accumulator piston.
- (3) Install piston and spring in housing.
- (4) Install end plate on housing.

TRANSFER PLATE

- (1) Install rear clutch and rear servo check balls in transfer plate (Fig. 76).
- (2) Install filter screen in upper housing separator plate (Fig. 77).
- (3) Align and position upper housing separator plate on transfer plate (Fig. 78).
- (4) Install brace plate (Fig. 78). Tighten brace attaching screws to 4 N·m (35 in. lbs.) torque.
- (5) Install remaining separator plate attaching screws. Tighten screws to 4 N·m (35 in. lbs.) torque.

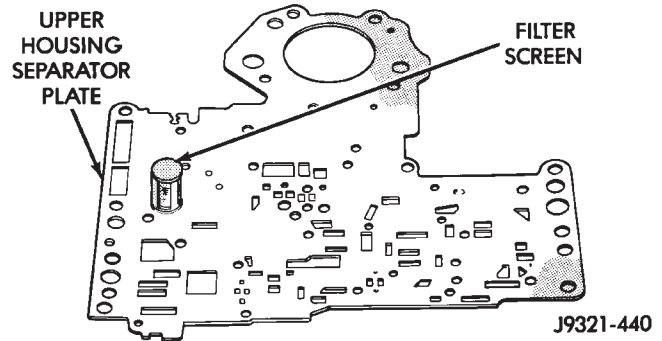


Fig. 77 Separator Plate Filter Screen Installation

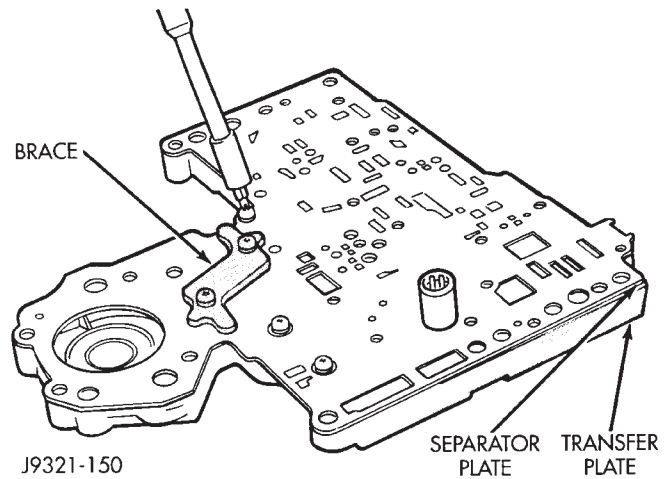


Fig. 78 Brace Plate

is approximately 4.8 mm (3/16 in.) in diameter. The remaining 6 check balls are approximately 6.3 mm (1/4 in.) in diameter.

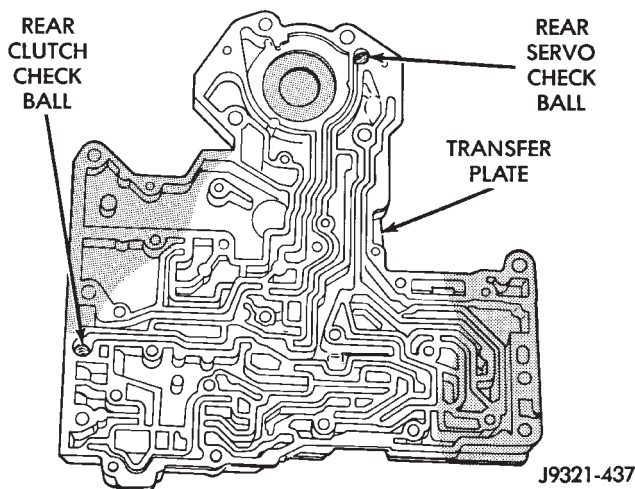


Fig. 76 Rear Clutch And Rear Servo Check Ball Locations

UPPER AND LOWER HOUSING

- (1) Position upper housing so internal passages and check ball seats are facing upward. Then install check balls in housing (Fig. 79). Eight check balls are used. The single large check ball is approximately 8.7 mm (11/32 in.) diameter. The single small check ball

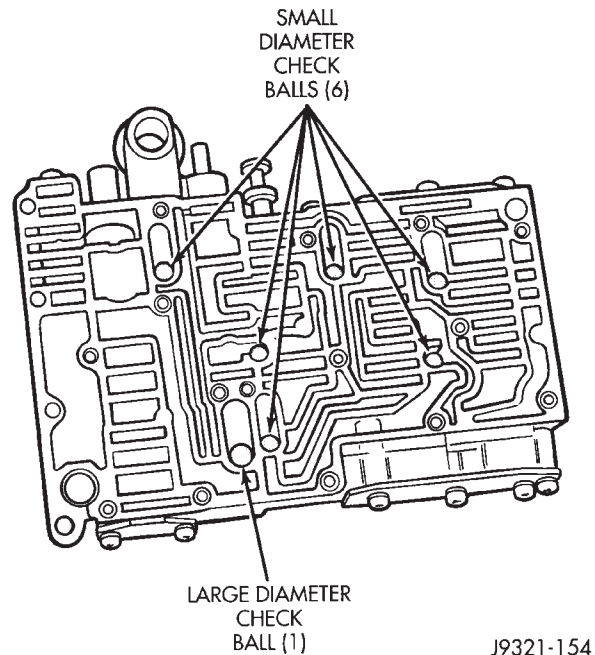


Fig. 79 Check Ball Locations In Upper Housing

DISASSEMBLY AND ASSEMBLY (Continued)

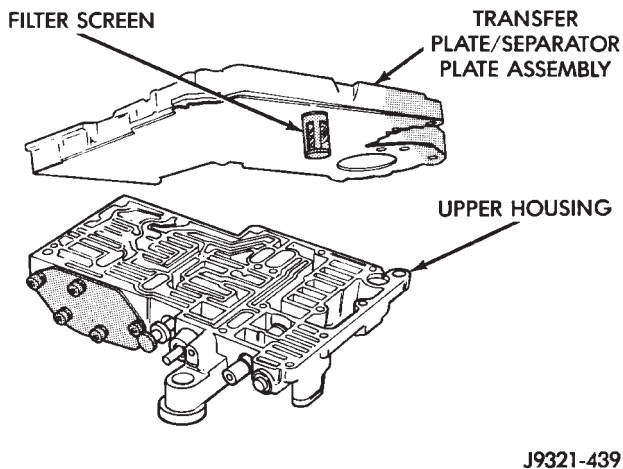
(2) Position assembled transfer plate and upper housing separator plate on upper housing (Fig. 80). Be sure filter screen is seated in proper housing recess.

(3) Install the ECE check ball into the transfer plate (Fig. 66). The ECE check ball is approximately 4.8 mm (3/16 in.) in diameter.

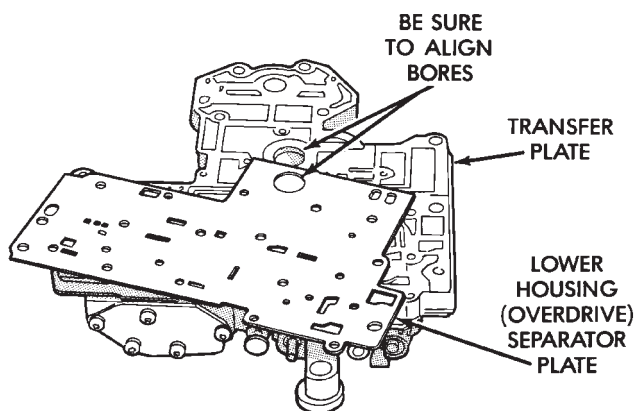
(4) Position lower housing separator plate on transfer plate (Fig. 81).

(5) Install lower housing on assembled transfer plate and upper housing (Fig. 82).

(6) Install and start all valve body screws by hand except for the screws to hold the boost valve tube brace. Save those screws for later installation. Then tighten screws evenly to 4 N·m (35 in. lbs.) torque. Start at center and work out to sides when tightening screws (Fig. 82).



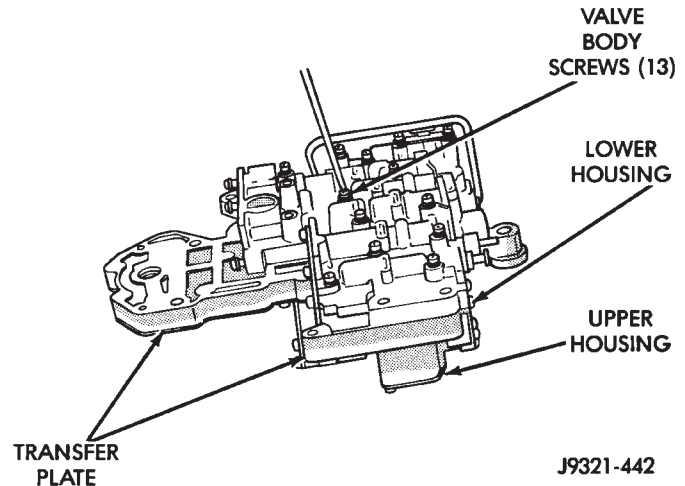
J9321-439

Fig. 80 Installing Transfer Plate On Upper Housing

J9321-441

Fig. 81 Lower Housing Separator Plate**UPPER HOUSING VALVE AND PLUG**

Refer to (Fig. 83), (Fig. 84) and (Fig. 85) to perform the following steps.



J9321-442

Fig. 82 Installing Lower Housing On Transfer Plate And Upper Housing

(1) Lubricate valves, plugs, springs with clean transmission fluid.

(2) Assemble regulator valve line pressure plug, sleeve, throttle plug and spring. Insert assembly in upper housing and install cover plate. Tighten cover plate screws to 4 N·m (35 in. lbs.) torque.

(3) Install 1-2 and 2-3 shift valves and springs.

(4) Install 1-2 shift control valve and spring.

(5) Install retainer, spring, limit valve, and 2-3 throttle plug from limit valve housing.

(6) Install limit valve housing and cover plate. Tighten screws to 4 N·m (35 in. lbs.).

(7) Install shuttle valve as follows:

(a) Insert plastic guides in shuttle valve secondary spring and install spring on end of valve.

(b) Install shuttle valve into housing.

(c) Hold shuttle valve in place.

(d) Compress secondary spring and install E-clip in groove at end of shuttle valve.

(e) Verify that spring and E-clip are properly seated before proceeding.

(8) Install shuttle valve cover plate. Tighten cover plate screws to 4 N·m (35 in. lbs.) torque.

(9) Install 1-2 and 2-3 valve governor plugs in valve body.

(10) Install shuttle valve primary spring and throttle plug.

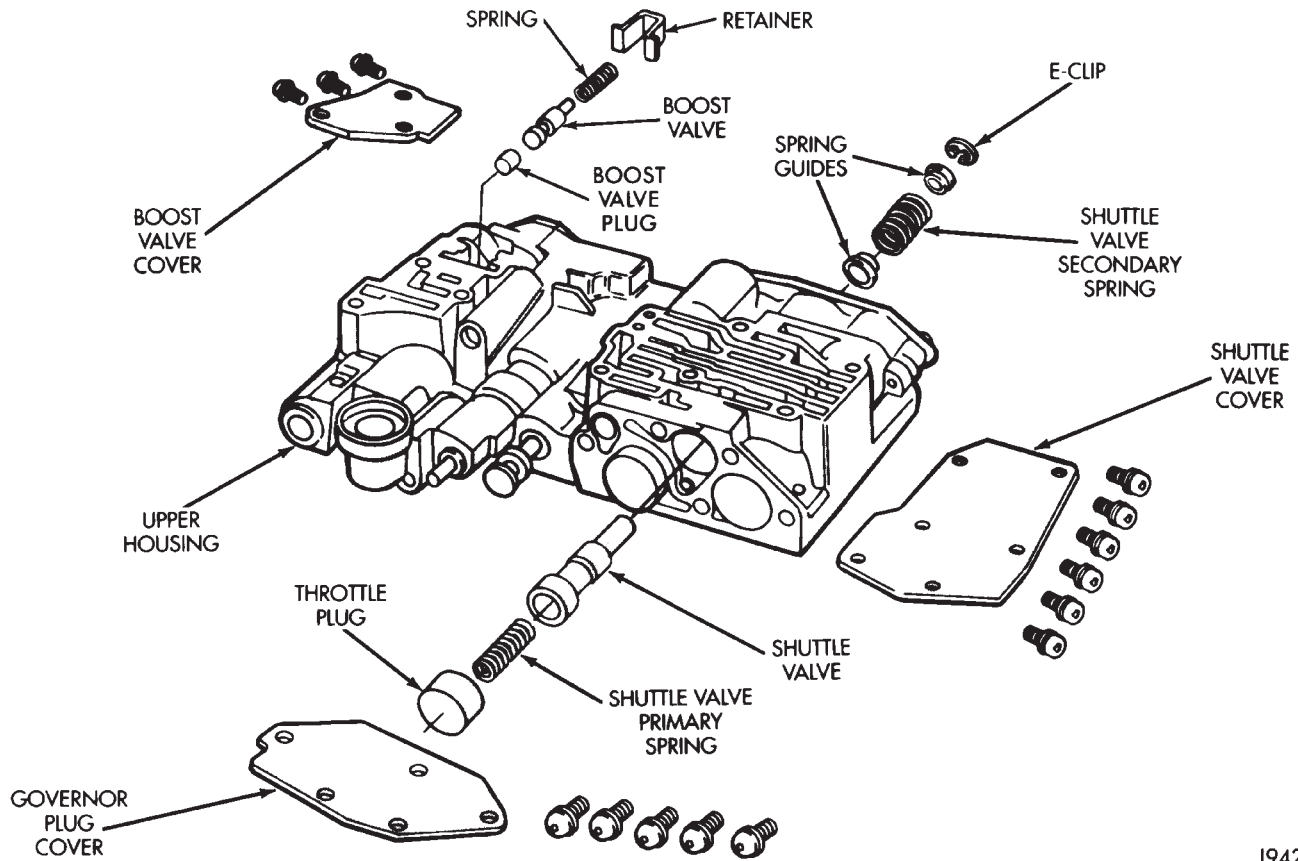
(11) Align and install governor plug cover. Tighten cover screws to 4 N·m (35 in. lbs.) torque.

BOOST VALVE TUBE AND BRACE

(1) Position valve body assembly so lower housing is facing upward (Fig. 86).

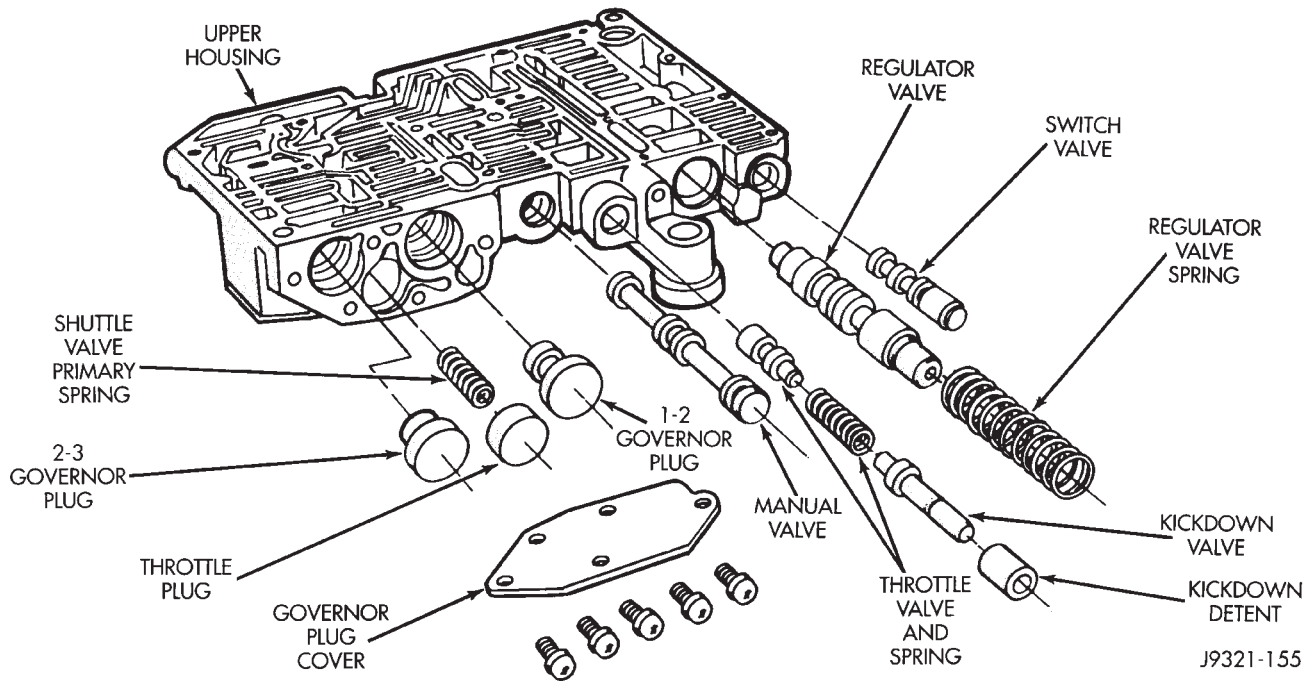
(2) Lubricate tube ends and housing ports with transmission fluid or petroleum jelly.

DISASSEMBLY AND ASSEMBLY (Continued)



J9421-217

Fig. 83 Shuttle And Boost Valve Components



J9321-155

Fig. 84 Upper Housing Control Valve Locations

DISASSEMBLY AND ASSEMBLY (Continued)

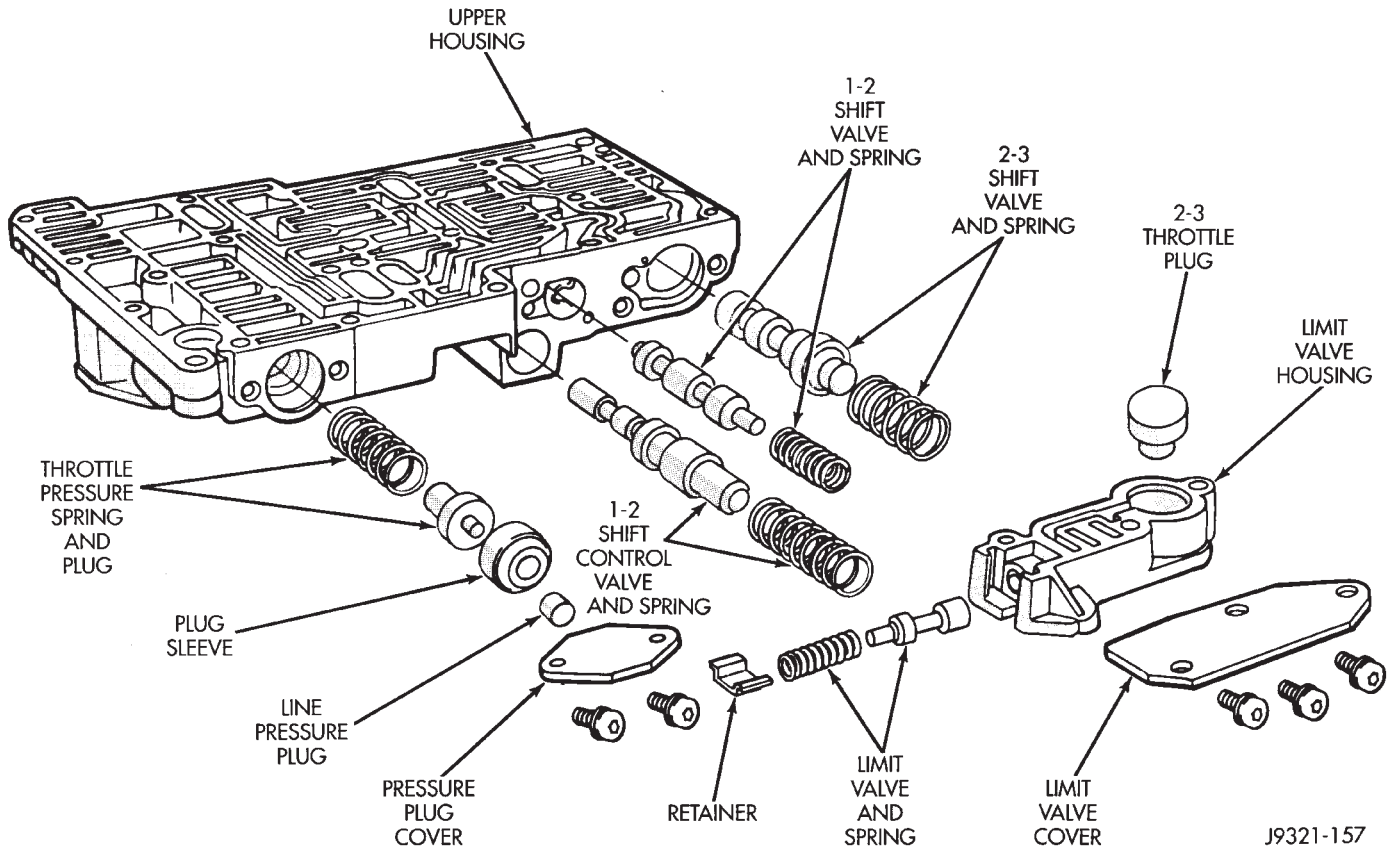


Fig. 85 Upper Housing Shift Valve And Pressure Plug Locations

(3) Start tube in lower housing port first. Then swing tube downward and work opposite end of tube into upper housing port (Fig. 86).

(4) Insert and seat each end of tube in housings.

(5) Slide tube brace under tube and into alignment with valve body screw holes (Fig. 87).

(6) Install and finger tighten three screws that secure tube brace to valve body housings (Fig. 87).

(7) Bend tube brace tabs up and against tube to hold it in position (Fig. 88).

(8) Tighten all valve body housing screws to 4 N·m (35 in. lbs.) torque after tube and brace are installed. Tighten screws in diagonal pattern starting at center and working outward.

3-4 ACCUMULATOR

(1) Position converter clutch valve and 3-4 shift valve springs in housing (Fig. 89).

(2) Loosely attach accumulator housing with right-side screw (Fig. 89). Install only one screw at this time as accumulator must be free to pivot upward for ease of installation.

(3) Install 3-4 shift valve and spring.

(4) Install converter clutch timing valve and spring.

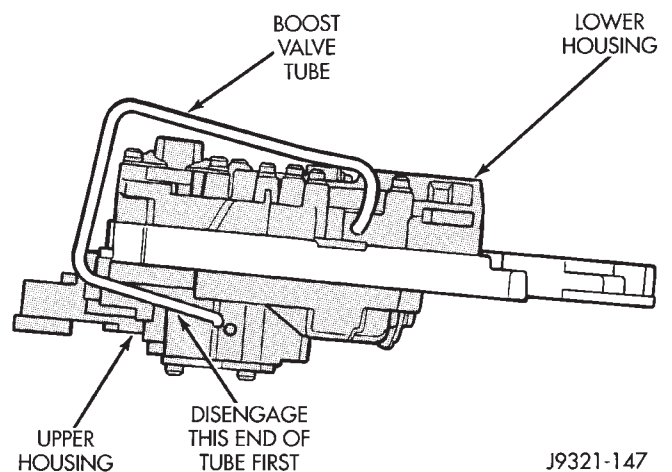


Fig. 86 Boost Valve Tube

(5) Position plug on end of converter clutch valve spring. Then compress and hold springs and plug in place with fingers of one hand.

(6) Swing accumulator housing upward over valve springs and plug.

(7) Hold accumulator housing firmly in place and install remaining two attaching screws. Be sure springs and clutch valve plug are properly seated (Fig. 90). Tighten screws to 4 N·m (35 in. lbs.).

DISASSEMBLY AND ASSEMBLY (Continued)

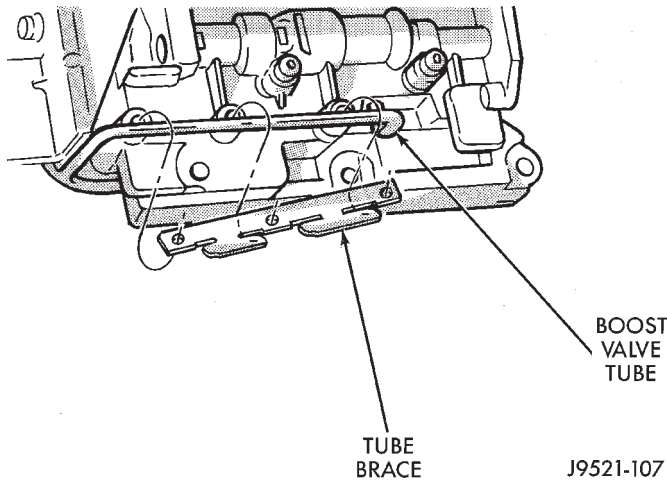


Fig. 87 Boost Valve Tube And Brace

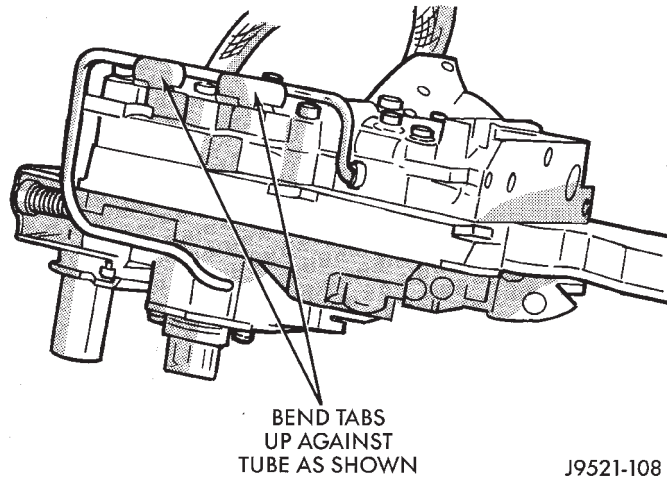


Fig. 88 Securing Boost Valve Tube With Brace Tabs

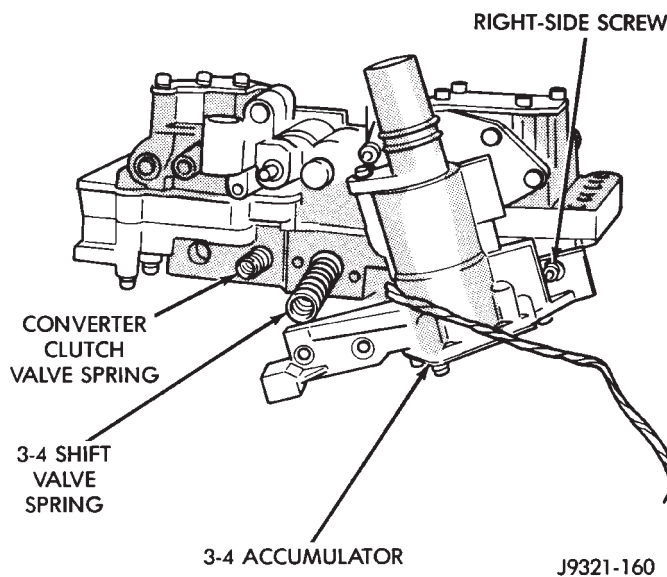


Fig. 89 Converter Clutch And 3-4 Shift Valve Springs

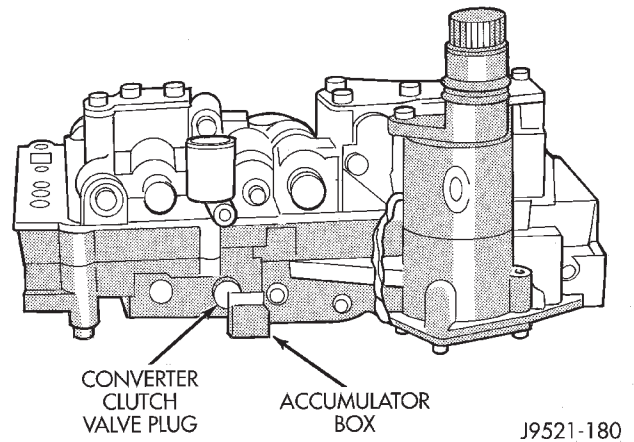


Fig. 90 Seating 3-4 Accumulator On Lower Housing VALVE BODY FINAL

- (1) Install boost valve, valve spring, retainer and cover plate. Tighten cover plate screws to 4 N·m (35 in. lbs.) torque.
- (2) Insert manual lever detent spring in upper housing.
- (3) Position detent ball on end of spring. Then hold detent ball and spring in detent housing with Retainer Tool 6583 (Fig. 91).
- (4) Install throttle lever in upper housing. Then install manual lever over throttle lever and start manual lever into housing.
- (5) Align manual lever with detent ball and manual valve. Hold throttle lever upward. Then press down on manual lever until fully seated. Remove detent ball retainer tool after lever is seated.
- (6) Then install manual lever seal, washer and E-clip.
- (7) Verify that throttle lever is aligned with end of kickdown valve stem and that manual lever arm is engaged in manual valve (Fig. 92).
- (8) Position line pressure adjusting screw in adjusting screw bracket.
- (9) Install spring on end of line pressure regulator valve.
- (10) Install switch valve spring on tang at end of adjusting screw bracket.
- (11) Install manual valve.
- (12) Install throttle valve and spring.
- (13) Install kickdown valve and detent.
- (14) Install pressure regulator valve.
- (15) Install switch valve.
- (16) Position adjusting screw bracket on valve body. Align valve springs and press bracket into place. Install short, upper bracket screws first and long bottom screw last. Verify that valve springs and bracket are properly aligned. Then tighten all three bracket screws to 4 N·m (35 in. lbs.) torque.

DISASSEMBLY AND ASSEMBLY (Continued)

(17) Lubricate solenoid case connector O-rings and shaft of manual lever with light coat of petroleum jelly.

(18) Obtain new fluid filter for valve body but do not install filter at this time.

(19) If line pressure and/or throttle pressure adjustment screw settings were not disturbed, continue with overhaul or reassembly. However, if adjustment screw settings **were** moved or changed, readjust as described in Valve Body Control Pressure Adjustment procedure.

(20) Attach solenoid case connector to 3-4 accumulator with shoulder-type screw. Connector has small locating tang that fits in dimple at top of accumulator housing (Fig. 93). Seat tang in dimple before tightening connector screw.

(21) Install solenoid assembly and gasket. Tighten solenoid attaching screws to 8 N·m (72 in. lbs.) torque.

(22) Verify that solenoid wire harness is properly routed (Fig. 94). **Solenoid harness must be clear of manual lever and park rod and not be pinched between accumulator housing and cover.**

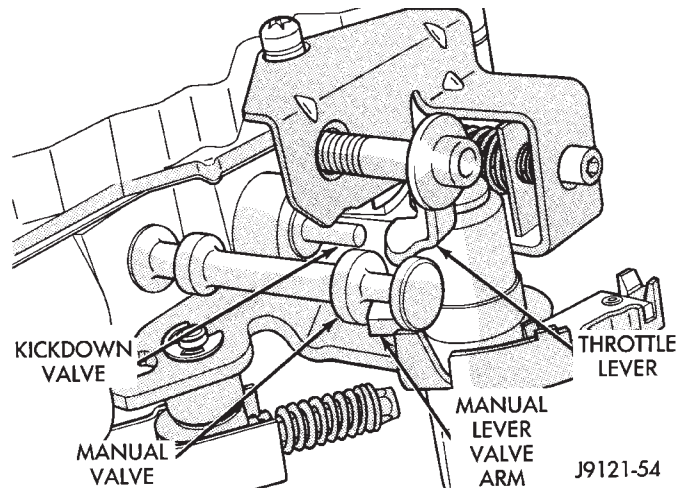


Fig. 92 Manual And Throttle Lever Alignment

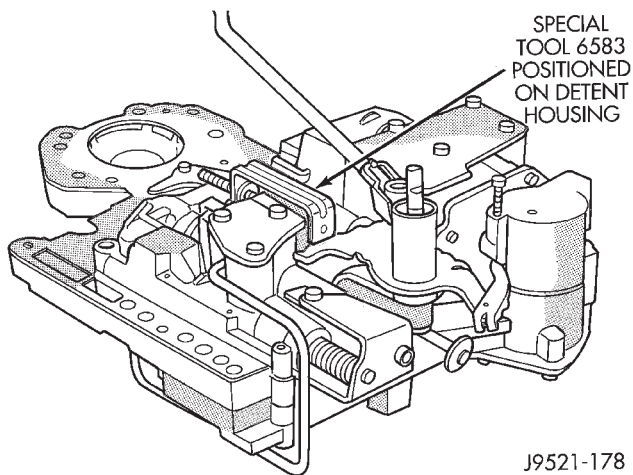


Fig. 91 Detent Ball Spring

GOVERNOR BODY, SENSOR AND SOLENOID

(1) Turn valve body assembly over so accumulator side of transfer plate is facing down.

(2) Install new O-rings on governor pressure solenoid and sensor (Fig. 95).

(3) Lubricate solenoid and sensor O-rings with clean transmission fluid.

(4) Install governor pressure sensor in governor body. Then secure sensor with M-shaped retaining clip (Fig. 95).

(5) Install governor pressure solenoid in governor body (Fig. 96). Push solenoid in until it snaps into place in body.

(6) Position governor body gasket on transfer plate (Fig. 97).

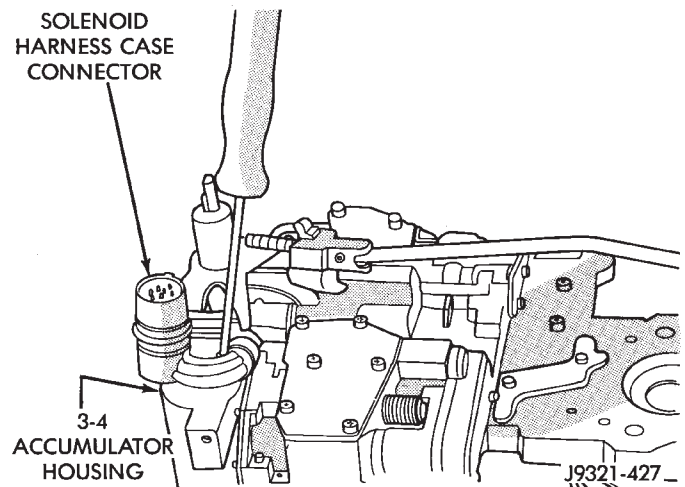


Fig. 93 Solenoid Harness Case Connector Shoulder Bolt

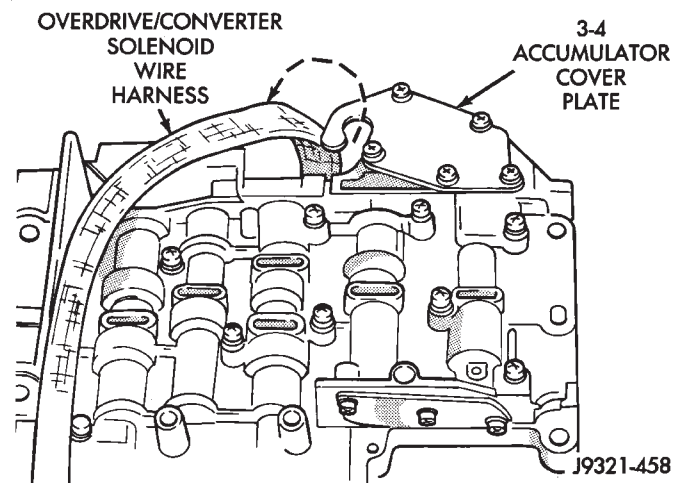


Fig. 94 Solenoid Harness Routing

DISASSEMBLY AND ASSEMBLY (Continued)

(7) Install retainer plate on governor body and around solenoid (Fig. 98). Be sure solenoid connector is positioned in retainer cutout.

(8) Align screw holes in governor body and transfer plate. Then install and tighten governor body screws to 4 N-m (35 in. lbs.) torque.

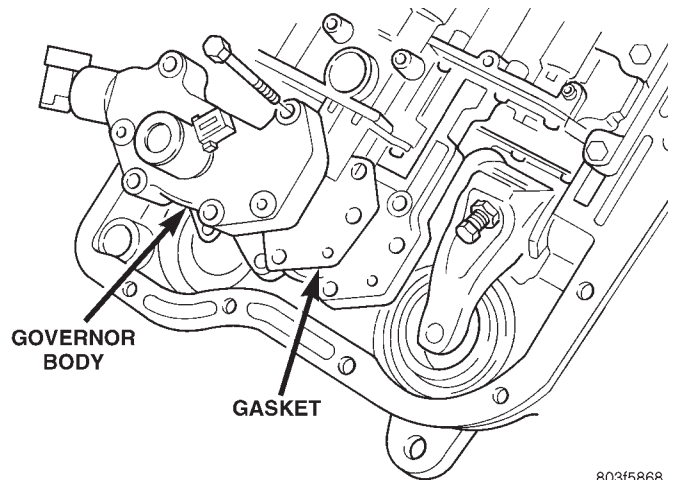
(9) Connect harness wires to governor pressure solenoid and governor pressure sensor (Fig. 99).

(10) Perform Line Pressure and Throttle Pressure adjustments, refer to adjustment section of this group for proper procedures.

(11) Install fluid filter and pan.

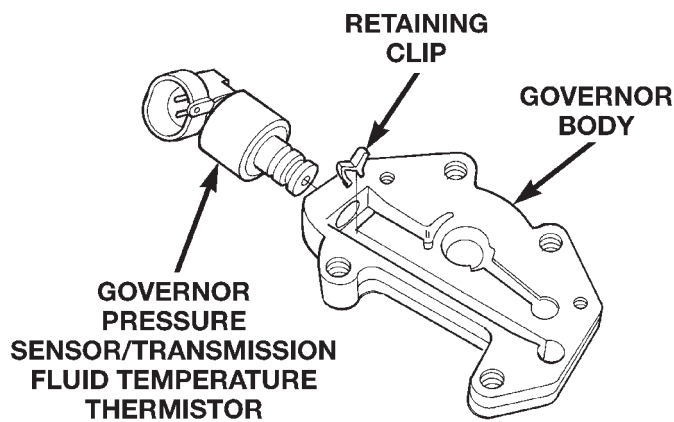
(12) Lower vehicle.

(13) Fill transmission with recommended fluid and road test vehicle to verify repair.



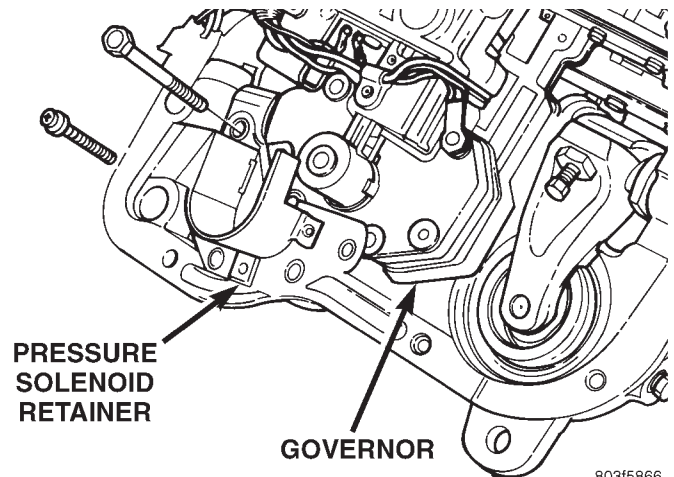
803f5868

Fig. 97 Governor Body And Gasket



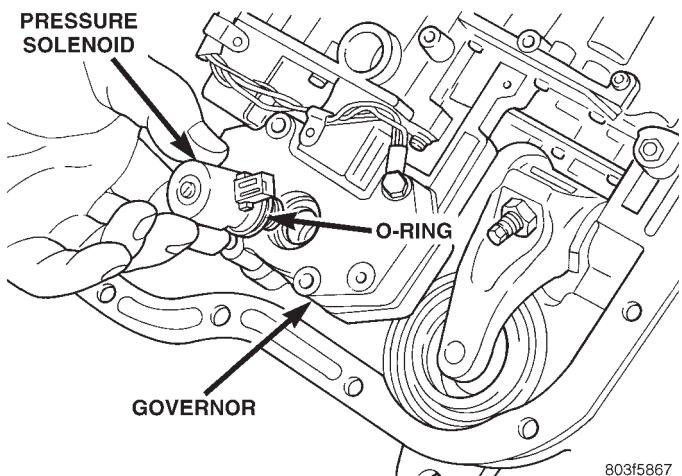
80a0c4fa

Fig. 95 Governor Pressure Sensor



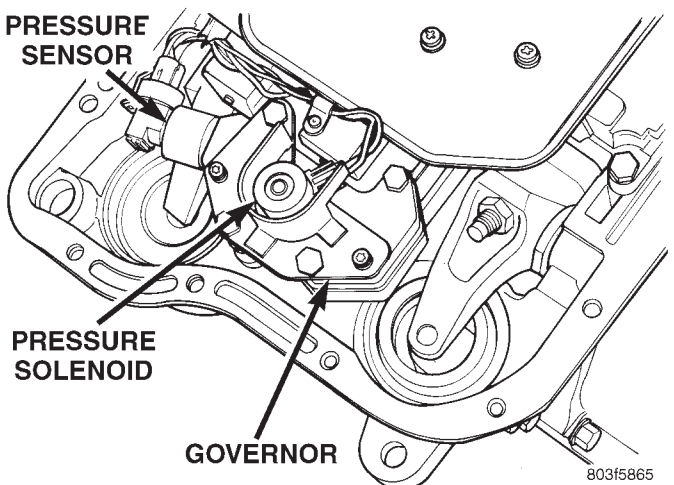
803f5866

Fig. 98 Pressure Solenoid Retainer



803f5867

Fig. 96 Governor Pressure Solenoid



803f5865

Fig. 99 Governor Pressure Sensor And Solenoid Connectors

TRANSMISSION

DISASSEMBLY

- (1) Drain fluid from transmission.
- (2) Clean exterior of transmission with suitable solvent or pressure washer.
- (3) Remove torque converter from front of transmission.

DISASSEMBLY AND ASSEMBLY (Continued)

- (4) Remove throttle and shift levers from valve body manual shaft and throttle lever shaft.
- (5) Place transmission in vertical position.
- (6) Measure and record the input shaft end-play measurement.
- (7) Mount transmission in repair stand C-3750-B or similar type stand (Fig. 100).

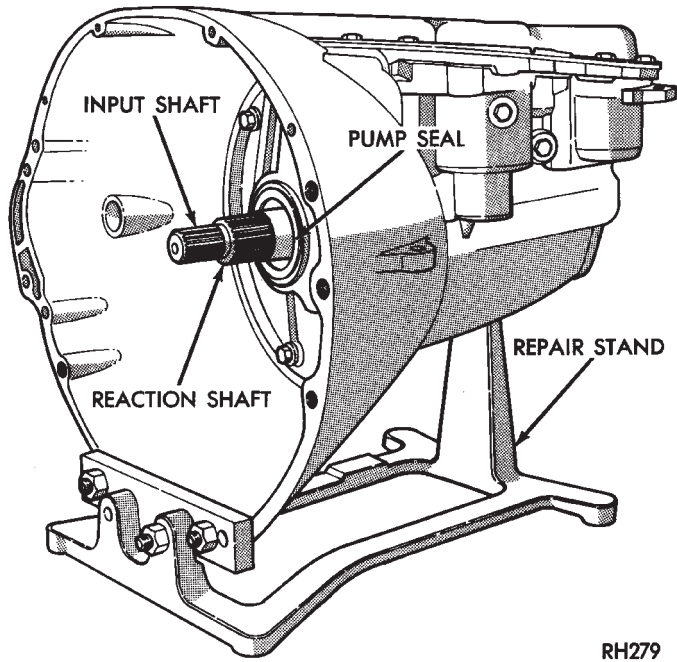


Fig. 100 Repair Stand

- (8) Remove fluid pan and filter.
- (9) Remove park/neutral position switch and seal (Fig. 101).
- (10) Remove valve body and electronic governor.
- (11) Remove accumulator outer spring, piston and inner spring (Fig. 102). Note position of piston and springs for assembly reference. Remove and discard piston seals if worn or cut.

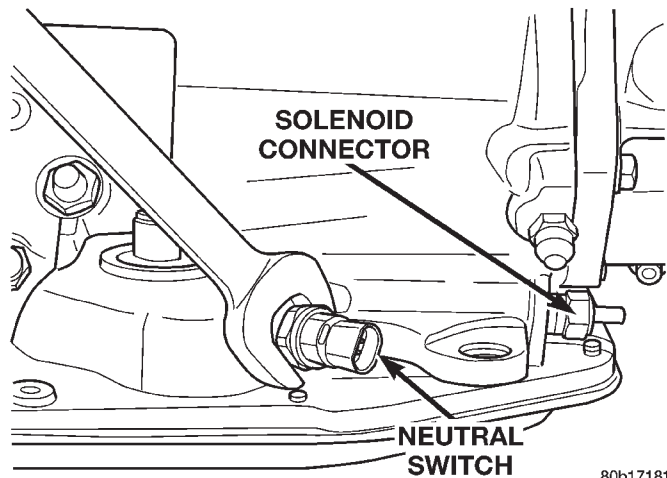


Fig. 101 Park/Neutral Position Switch

- (12) Remove pump oil seal with suitable pry tool or slide-hammer mounted screw.
- (13) Remove front band lever pin access plug (Fig. 103). Use square end of 1/4 in. drive extension to remove plug as shown.

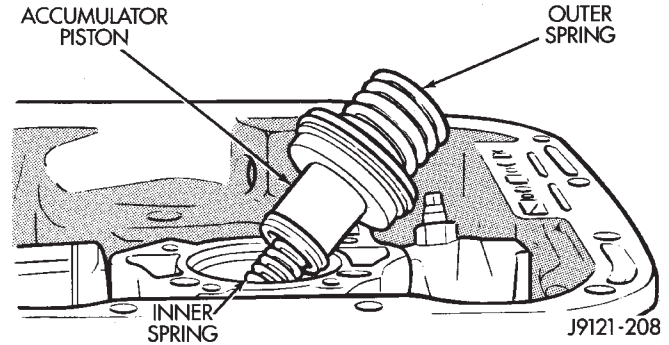


Fig. 102 Accumulator Component Removal

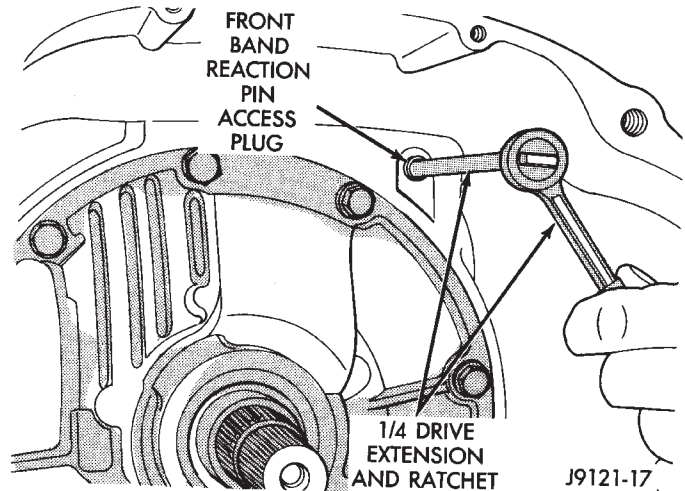


Fig. 103 Front Band Lever Pin Access Plug

- (14) Remove oil pump and reaction shaft support assembly as follows:

(a) Tighten front band adjusting screw until band is tight around front clutch retainer (Fig. 104). This will prevent retainer from coming out with pump and possibly damaging clutch or pump components.

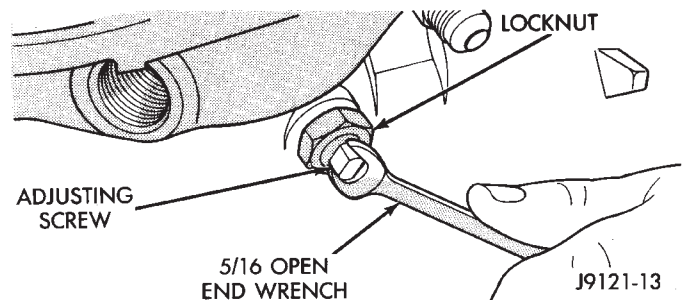


Fig. 104 Tightening Front Band To Hold Front Clutch In Place

80b17181

J9121-13

J9121-208

RH279

DISASSEMBLY AND ASSEMBLY (Continued)

- (b) Remove oil pump bolts.
- (c) Thread Slide Hammer Tools C-3752 into threaded holes in flange of oil pump housing (Fig. 105).
- (d) Remove oil pump and reaction shaft support by bumping slide hammers outward alternately to pull pump from case (Fig. 106).
- (15) Remove oil pump gasket (Fig. 107). Note gasket position in case for assembly reference.
- (16) Loosen front band adjusting screw until band is completely loose.
- (17) Remove front band strut and anchor (Fig. 108).
- (18) Squeeze front band together slightly and slide band over front clutch retainer and out of case (Fig. 109).

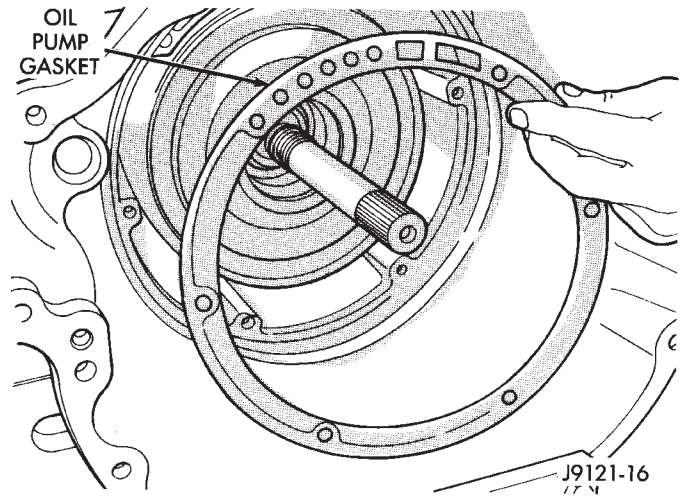


Fig. 107 Oil Pump Gasket

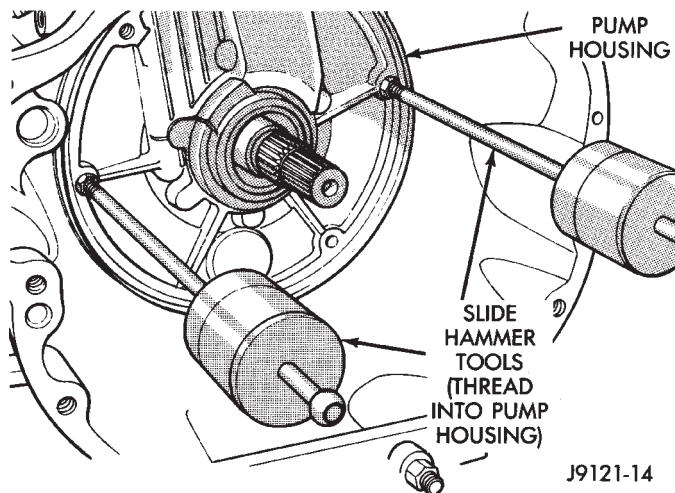


Fig. 105 Oil Pump Removal Tools

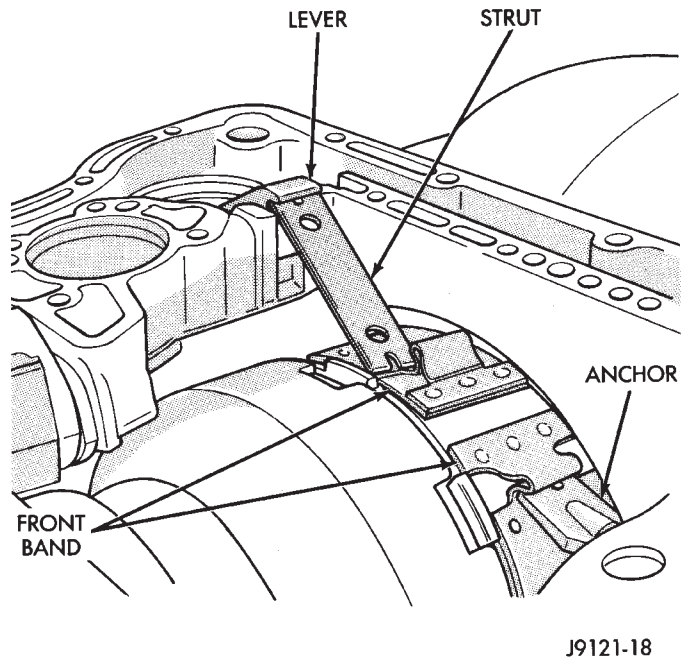


Fig. 108 Front Band Linkage

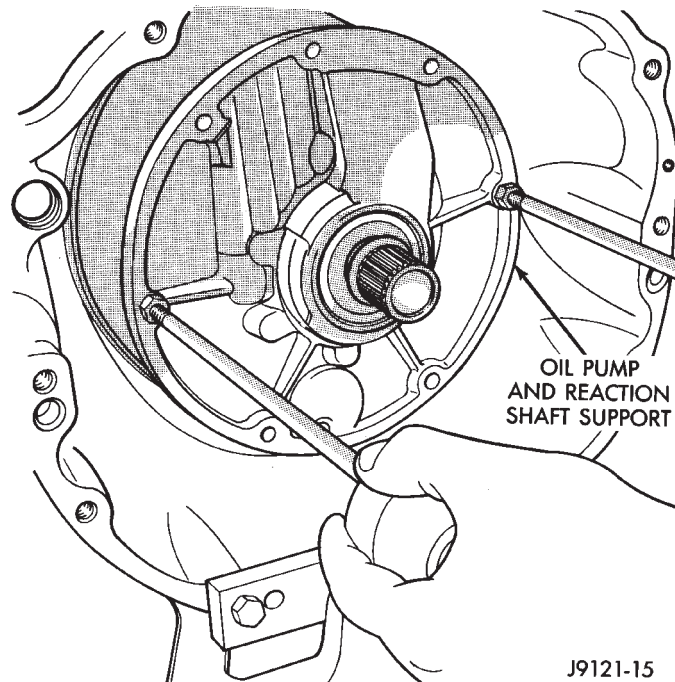


Fig. 106 Oil Pump Removal

DISASSEMBLY AND ASSEMBLY (Continued)

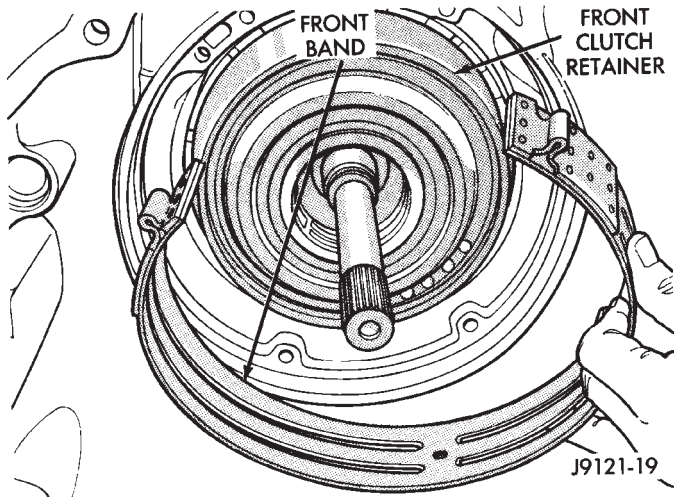


Fig. 109 Front Band

(19) Remove front and rear clutch assemblies as a unit (Fig. 110).

(20) Remove front band reaction pin and lever. Start pin through lever and out of case bore with drift or punch. Then use pencil magnet to withdraw pin completely (Fig. 111).

(21) Remove intermediate shaft thrust washer. Triangular shaped washer will either be on shaft pilot hub or in rear clutch retainer (Fig. 112).

(22) Remove thrust plate from intermediate shaft hub (Fig. 113).

(23) Remove intermediate shaft-planetary gear-train assembly (Fig. 114).

(24) If overdrive unit is not to be serviced, install Alignment Shaft 6227-2 into the overdrive unit to

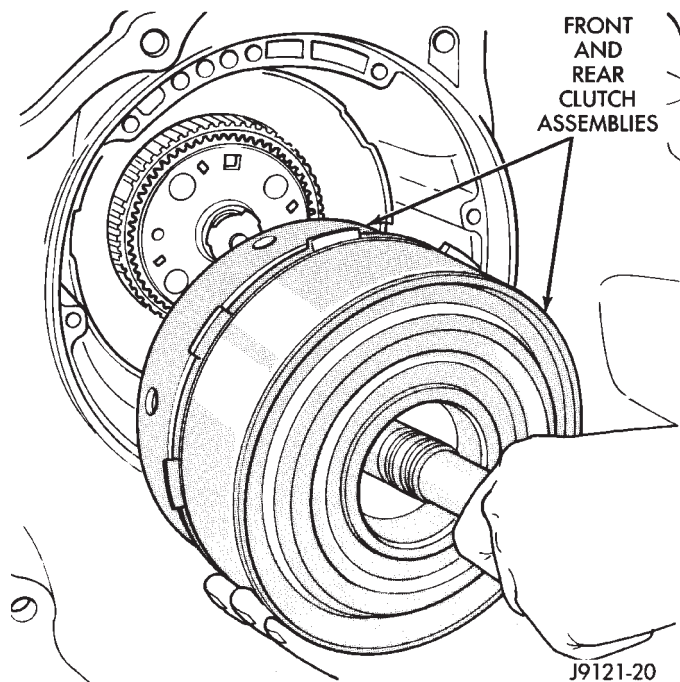


Fig. 110 Removing Front/Rear Clutch Assemblies

prevent misalignment of the overdrive clutches during service of main transmission components.

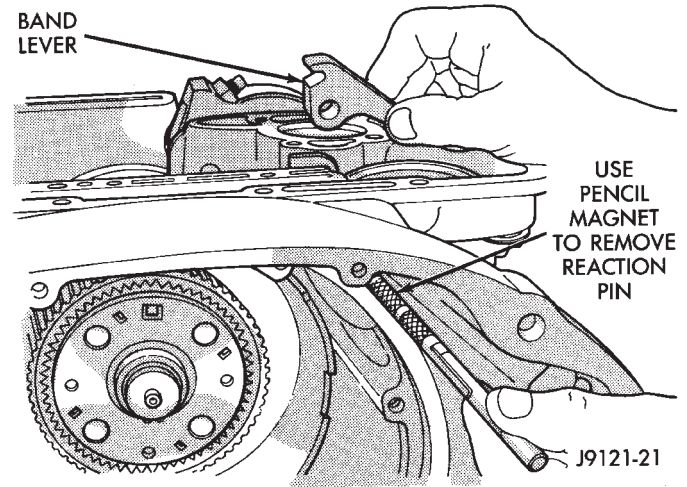


Fig. 111 Front Band Lever And Pin

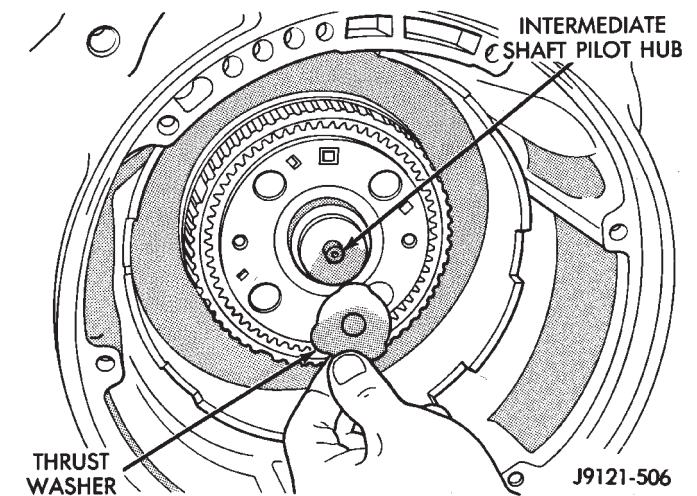


Fig. 112 Intermediate Shaft Thrust Washer

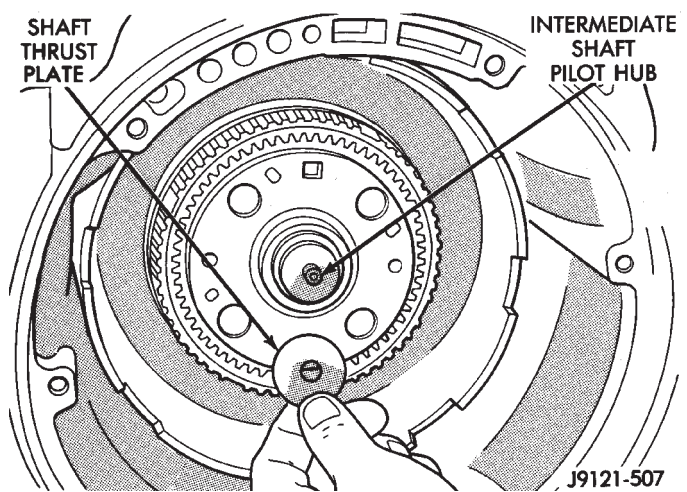


Fig. 113 Intermediate Shaft Thrust Plate

DISASSEMBLY AND ASSEMBLY (Continued)

- (25) Loosen rear band locknut and loosen adjusting screw 3-4 turns.
- (26) Remove snap ring that retains low-reverse drum on overdrive piston retainer hub (Fig. 115).

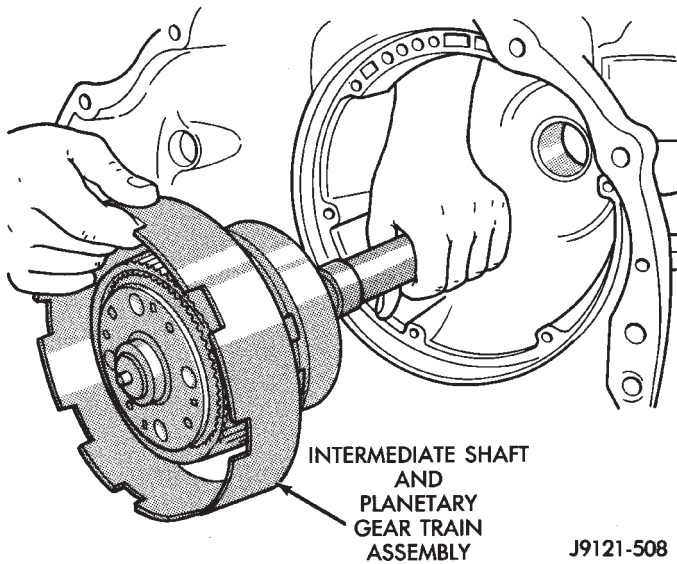


Fig. 114 Intermediate Shaft And Planetary Geartrain

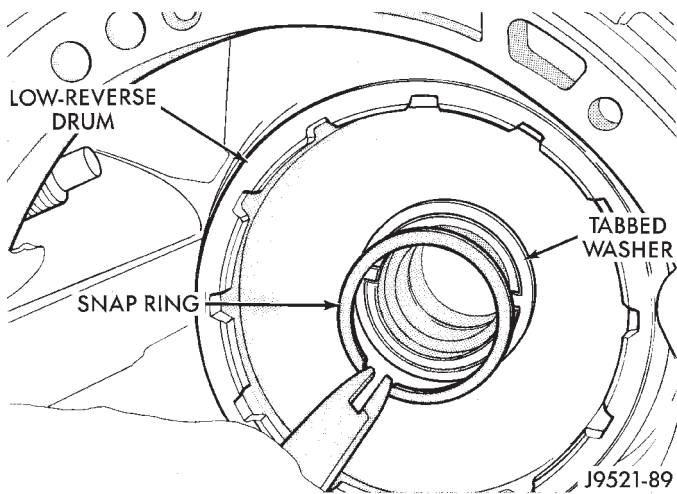


Fig. 115 Low-Reverse Drum Snap Ring

- (27) Slide low-reverse drum and thrust washer off piston retainer hub and out of rear band (Fig. 116).
- (28) Note that overrunning clutch race will remain on splines of low-reverse drum after removal (Fig. 117). **The race is a permanent press fit on the hub splines. Do not attempt to remove the race.**
- (29) Remove overrunning clutch assembly (Fig. 118). Assembly can be removed without displacing rollers and springs if care is exercised. Note position of rollers and springs for assembly reference.
- (30) Remove rear band adjusting lever, reaction lever and pin (Fig. 119).

- (31) Remove strut from rear band. Keep strut with levers and pin for cleaning, inspection and assembly reference.
- (32) Remove rear band and link (Fig. 120).

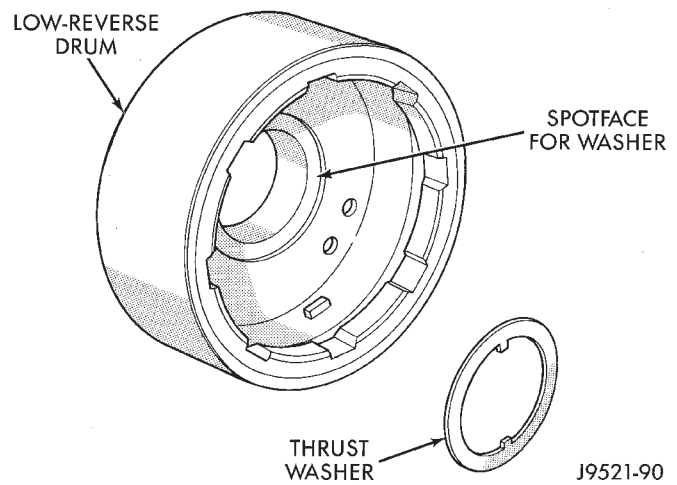


Fig. 116 Low-Reverse Drum And Thrust Washer

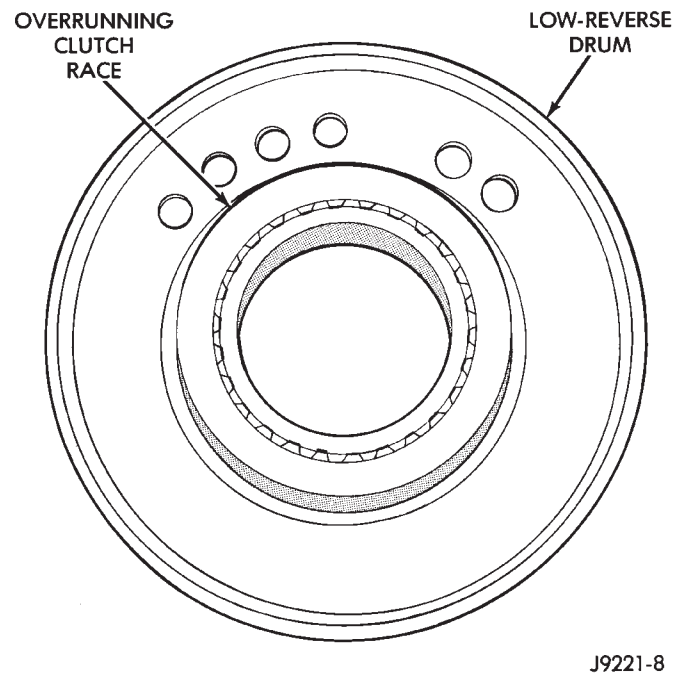


Fig. 117 Overrunning Clutch Race Position On Low-Reverse Drum

- (33) Compress front servo rod guide with large C-clamp and Tool C-4470, or Compressor Tool C-3422-B (Fig. 121). Compress guide only enough to permit snap ring removal (about 1/8 in.).
- (34) Remove servo piston snap ring (Fig. 121). Unseat one end of ring. Then carefully work removal tool around back of ring until free of ring groove. **Exercise caution when removing snap ring. Servo bore can be scratched or nicked if care is not exercised.**

DISASSEMBLY AND ASSEMBLY (Continued)

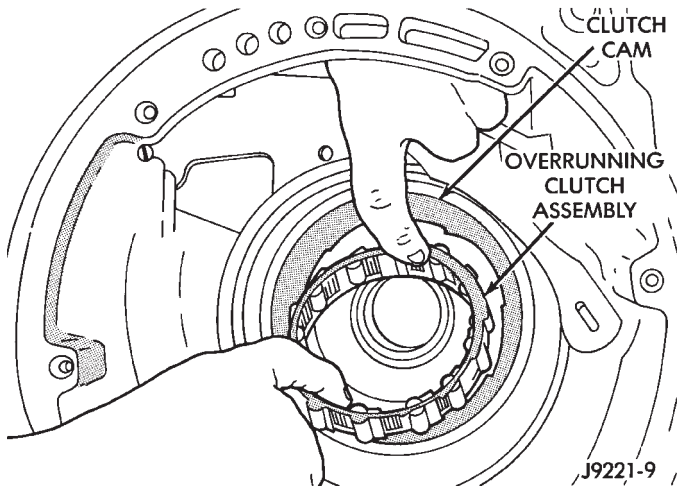


Fig. 118 Overrunning Clutch

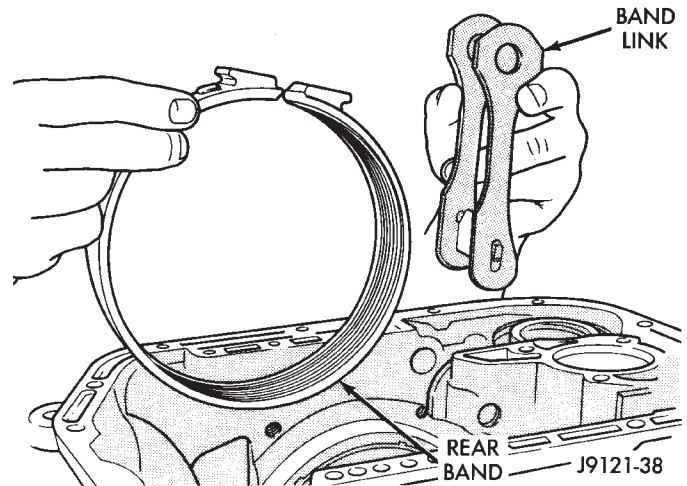


Fig. 120 Rear Band And Link

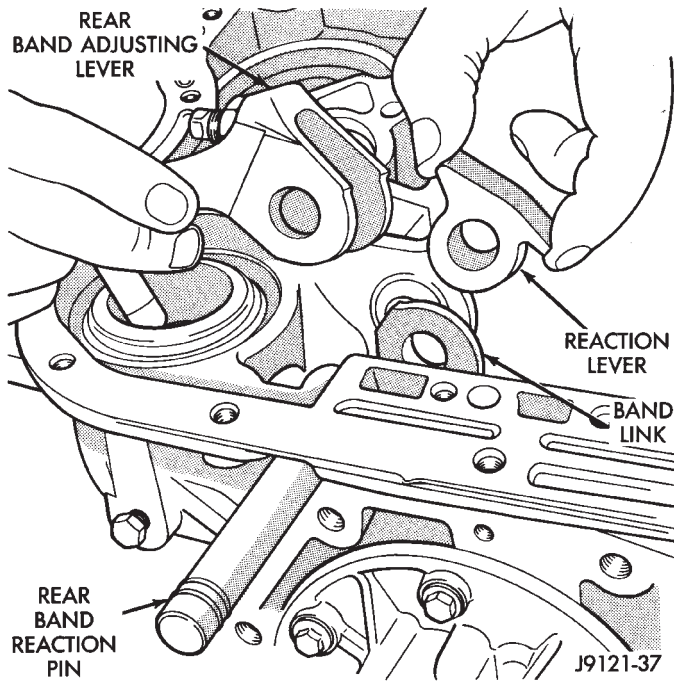


Fig. 119 Rear Band Levers And Pins

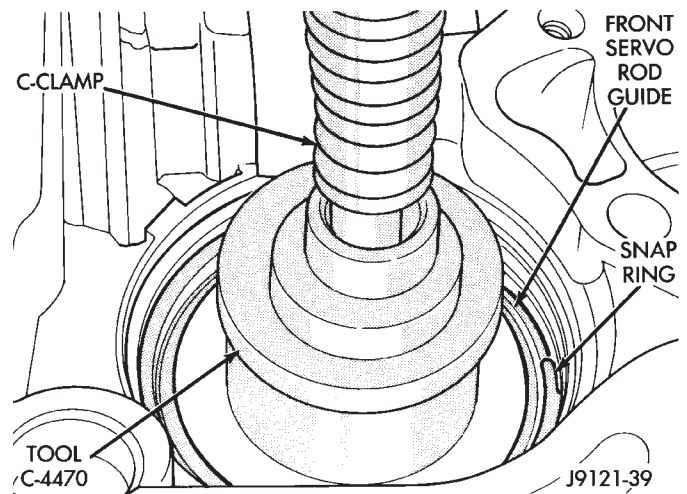


Fig. 121 Front Servo Retaining Snap Ring

(35) Remove tools and remove servo piston and spring.

(36) Compress rear servo piston with C-clamp and Tool C-4470, or Valve Spring Compressor C-3422-B (Fig. 122). Compress servo spring retainer only enough to permit snap ring removal.

(37) Remove servo piston snap ring (Fig. 122). Start one end of ring out of bore. Then carefully work removal tool around back of snap ring until free of ring groove. **Exercise caution when removing snap ring. Servo bore can be scratched or nicked if care is not exercised.**

(38) Remove tools and remove rear servo retainer, spring and piston assembly.

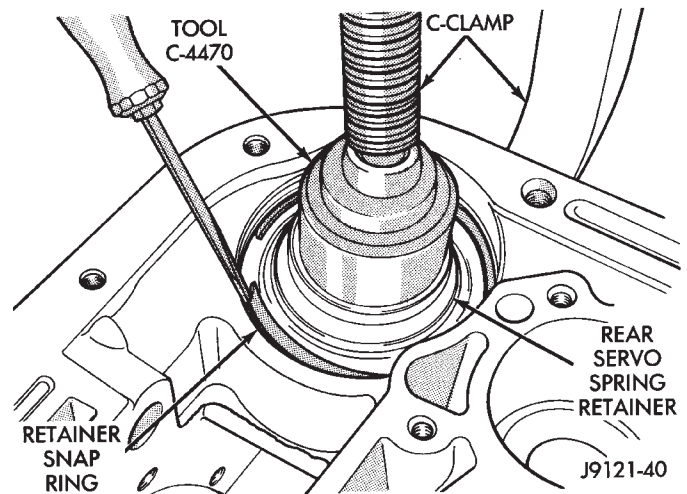


Fig. 122 Rear Servo Retaining Snap Ring

ASSEMBLY

Do not allow dirt, grease, or foreign material to enter the case or transmission components during

DISASSEMBLY AND ASSEMBLY (Continued)

assembly. Keep the transmission case and components clean. Also make sure the tools and workbench area used for reassembly operations are equally clean.

Shop towels used for wiping off tools and your hands must be made from **lint free** materials. Lint will stick to transmission parts and could interfere with valve operation or even restrict fluid passages.

Lubricate transmission clutch and gear components with Mopar® ATF Plus 3, type 7176, during reassembly. Soak clutch discs in transmission fluid before installation.

Use Mopar® Door Ease, or Ru-Glyde on piston seals and O-rings to ease installation. Petroleum jelly can also be used to lubricate and hold thrust washers and plates in position during assembly.

Do not use chassis grease, bearing grease, white grease, or similar lubricants on any part. These types of lubricants can eventually block or restrict fluid passages and valve operation. Use petroleum jelly only.

Do not force parts into place. The transmission components and sub-assemblies are easily installed by hand when properly aligned. If a part seems difficult to install, it is either misaligned or incorrectly assembled. Verify that thrust washers, thrust plates and seal rings are correctly positioned.

The planetary geartrain, front/rear clutch assemblies and oil pump are all much easier to install when the transmission case is upright. Either tilt the case upward with wood blocks, or cut a hole in the bench large enough for the intermediate shaft and rear support. Then lower the shaft and support into the hole and support the rear of the case directly on the bench.

FRONT/REAR SERVO

(1) Lubricate rear servo piston seal with Mopar® Door Ease or ATF Plus 3. Lubricate servo bore in case with ATF Plus 3.

(2) Install rear servo piston in case. Position piston at slight angle to bore and insert piston with twisting motion (Fig. 123).

(3) Install rear servo spring and retainer in case bore (Fig. 124). Be sure spring is seated on piston.

(4) Compress rear servo piston with C-clamp or Valve Spring Compressor C-3422-B and install servo piston snap ring (Fig. 125).

(5) Lubricate front servo piston components and servo bore in case with transmission fluid.

(6) Install front servo piston in bore. Carefully "run" small, suitable tool around piston ring to press it back into groove and ease installation (Fig. 126). Rotate piston into bore at same time. Rock piston slightly to ease piston ring past snap ring groove and into bore.

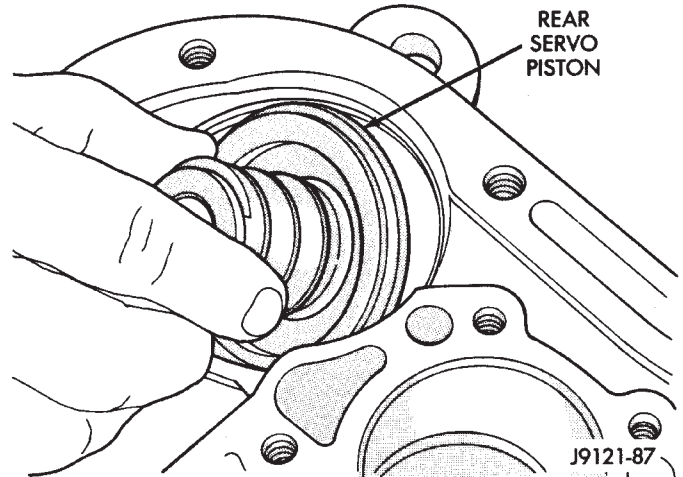


Fig. 123 Rear Servo Piston

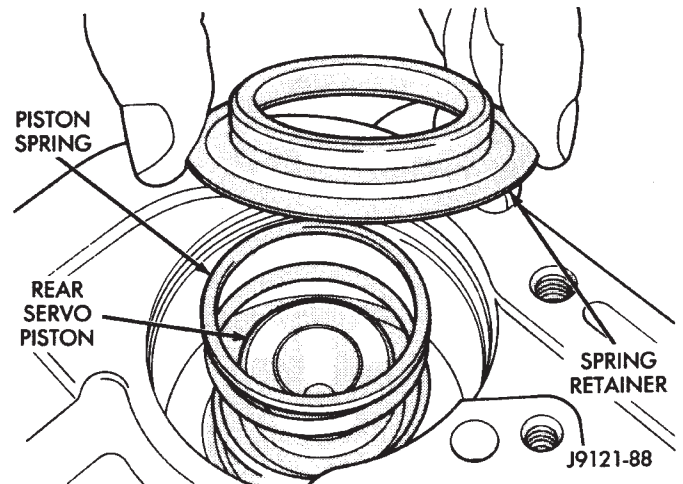


Fig. 124 Rear Servo Piston Spring And Retainer

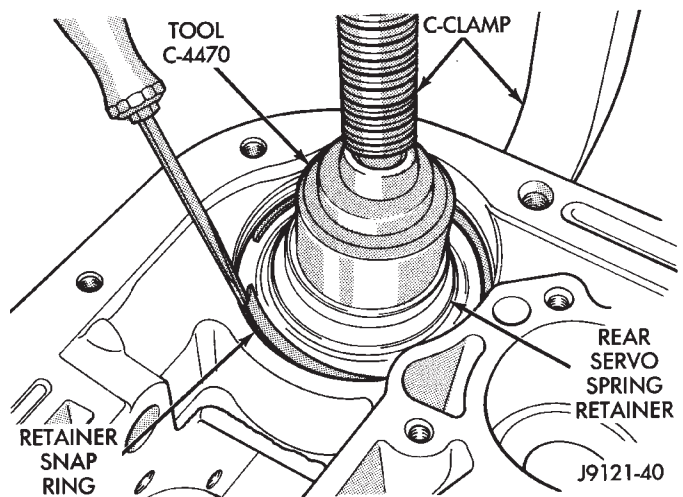


Fig. 125 Rear Servo Snap Ring

(7) Bottom front servo piston in bore and install servo spring.

(8) Install front servo piston rod guide as follows:

DISASSEMBLY AND ASSEMBLY (Continued)

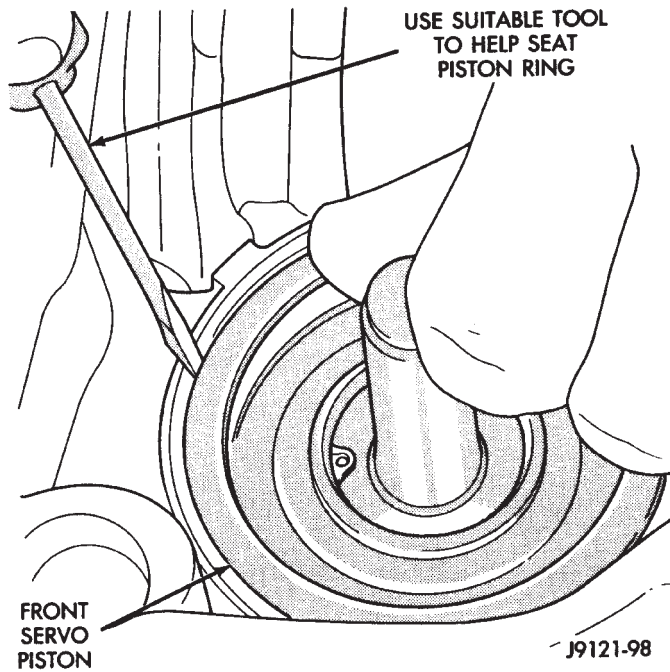
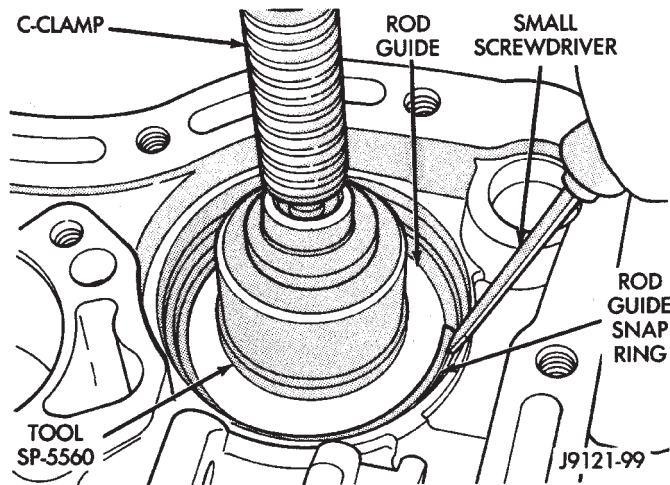


Fig. 126 Front Servo Piston

(a) Place Tool SP-5560 (or similar size tool) on guide and position C-clamp on tool and case (Fig. 127).

(b) Slowly compress rod guide while simultaneously easing seal ring into bore with suitable tool.

(9) Install rod guide snap ring (Fig. 127).



**Fig. 127 Front Servo Rod Guide And Snap Ring
OVERRUNNING CLUTCH, REAR BAND, AND LOW-REVERSE DRUM**

(1) Install overrunning clutch components if not yet installed.

(2) Position rear band and link in case (Fig. 128).

(3) Install low-reverse drum (Fig. 129). Slide drum through rear band, onto piston retainer hub and into engagement with overrunning clutch and race.

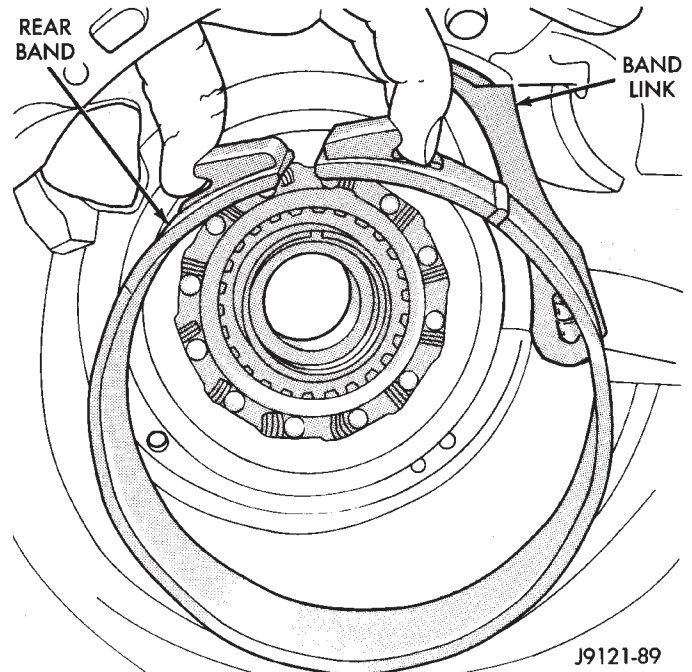


Fig. 128 Rear Band And Link

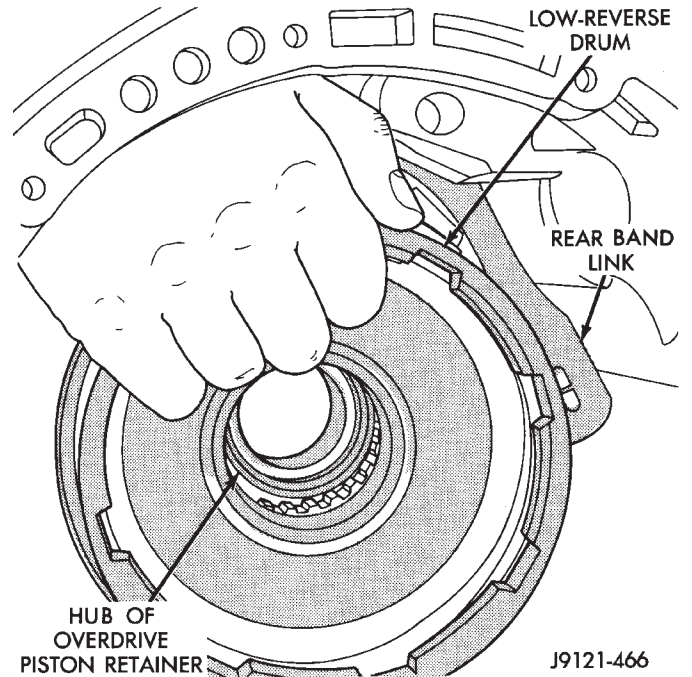


Fig. 129 Low-Reverse Drum

(4) Install thrust washer in low-reverse drum spot-face (Fig. 130). Use petroleum jelly to hold washer in place.

(5) Install snap ring that secures low-reverse drum to piston retainer hub (Fig. 130).

(6) Insert band reaction pin part way into case and band link (Fig. 131).

(7) Install rear band adjusting lever, reaction lever, and strut (Fig. 132). Be sure levers and strut are aligned and engaged before seating band reaction pin in case.

DISASSEMBLY AND ASSEMBLY (Continued)

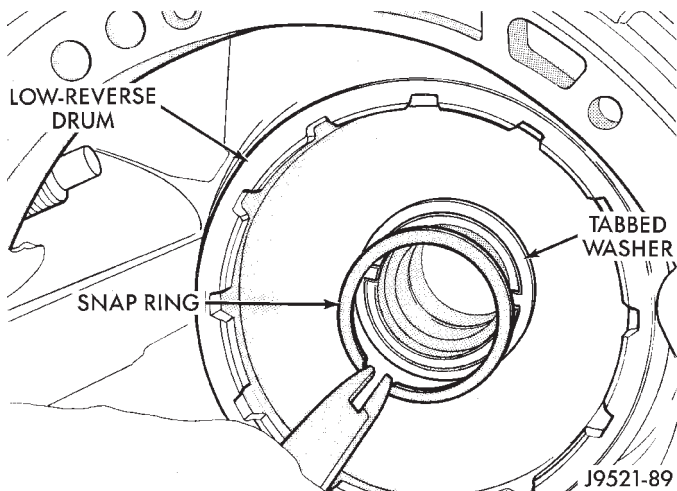


Fig. 130 Low-Reverse Drum Snap Ring

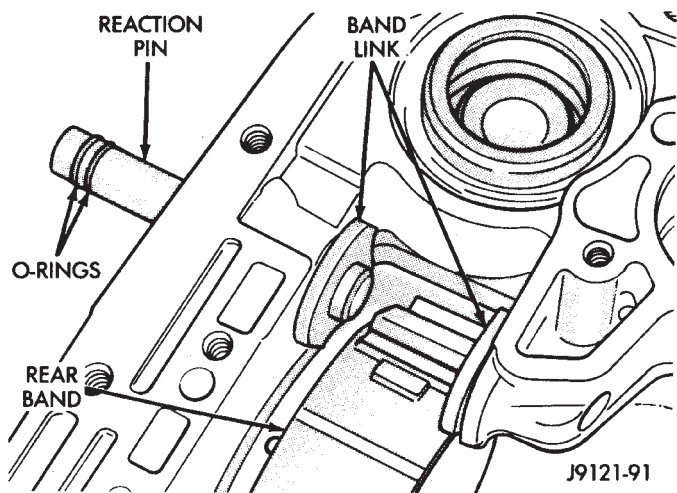


Fig. 131 Rear Band Reaction Pin

PLANETARY GEARTRAIN, FRONT/REAR CLUTCH, AND FRONT BAND

(1) Remove Alignment Shaft 6227-2, if installed previously.

(2) Install assembled intermediate shaft and planetary geartrain (Fig. 133). **Support shaft carefully during installation. Do not allow shaft bearing/bushing surfaces to become nicked or scratched.**

(3) Lubricate intermediate shaft thrust plate with petroleum jelly and install plate on shaft pilot hub (Fig. 134).

(4) Check input shaft front seal rings, fiber thrust washer and rear seal ring (Fig. 135). Be ends of rear seal ring are hooked together and diagonal cut ends of front seal rings are firmly seated against each other as shown. Lubricate seal rings with petroleum jelly after checking them.

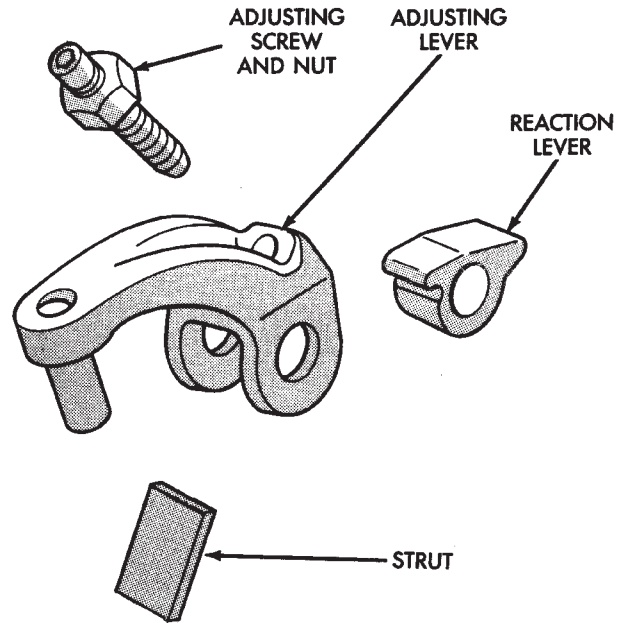


Fig. 132 Rear Band Levers And Strut

(5) Assemble front and rear clutches (Fig. 136). Align lugs on front clutch discs. Mount front clutch on rear clutch. Turn front clutch retainer back and forth until front clutch discs are fully seated on rear clutch splined hub.

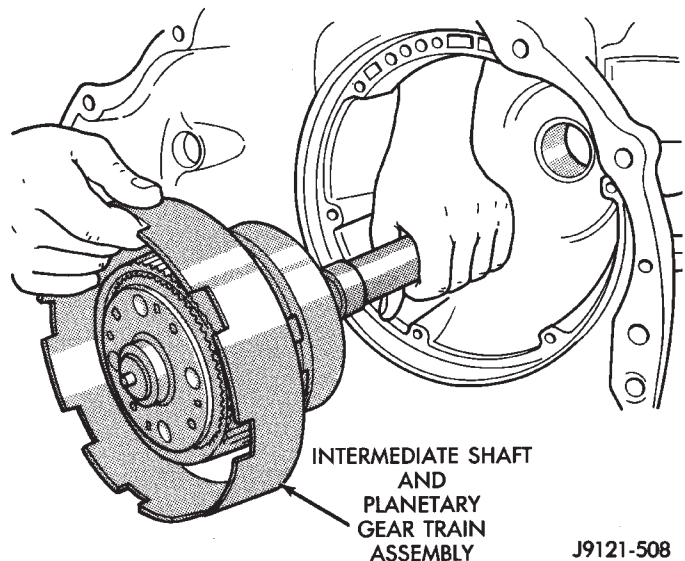


Fig. 133 Intermediate Shaft And Planetary Geartrain

(6) Install intermediate shaft thrust washer in hub of rear clutch retainer (Fig. 137). Use petroleum jelly to hold washer in place. Position washer so grooves are facing outward. **Washer only fits one way in clutch retainer hub.**

(7) Place transmission case in upright position, or place blocks under front end of transmission repair

DISASSEMBLY AND ASSEMBLY (Continued)

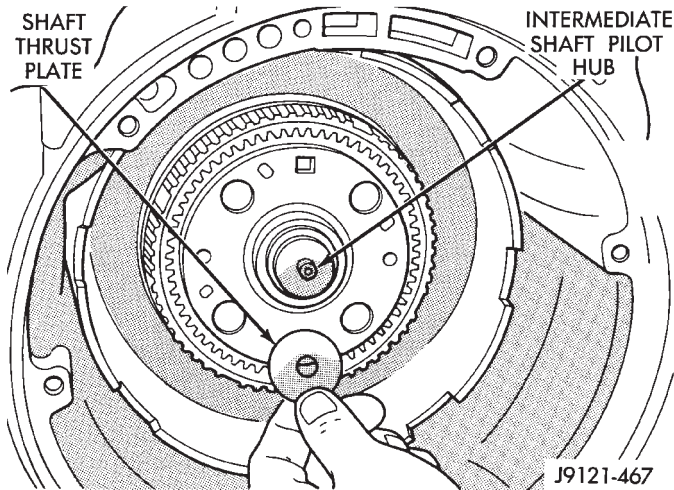


Fig. 134 Intermediate Shaft Thrust Plate

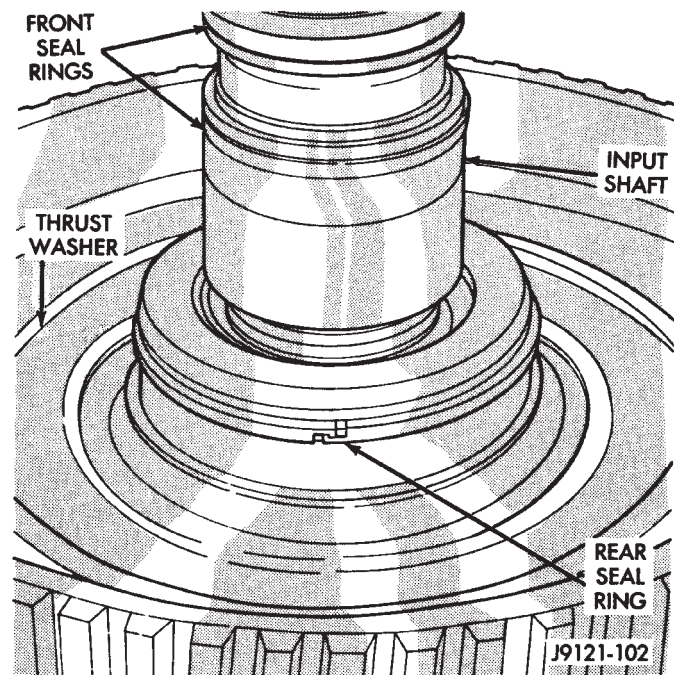


Fig. 135 Input Shaft Seal Ring And Thrust Washer

stand to tilt case rearward. This makes it easier to install front/rear clutch assembly.

(8) Align discs in rear clutch. Then install and engage assembly in front planetary and driving shell (Fig. 138). Turn clutch retainers back and forth until both clutches are seated.

(9) Position front band lever in case and over servo rod guide. Then install front band lever pin in case and slide it through lever.

(10) Coat threads of front band pin access plug with sealer and install it in case. Tighten plug to 17 N·m (13 ft. lbs.) torque.

(11) Slide front band over front clutch retainer and install front band strut and anchor (Fig. 139).

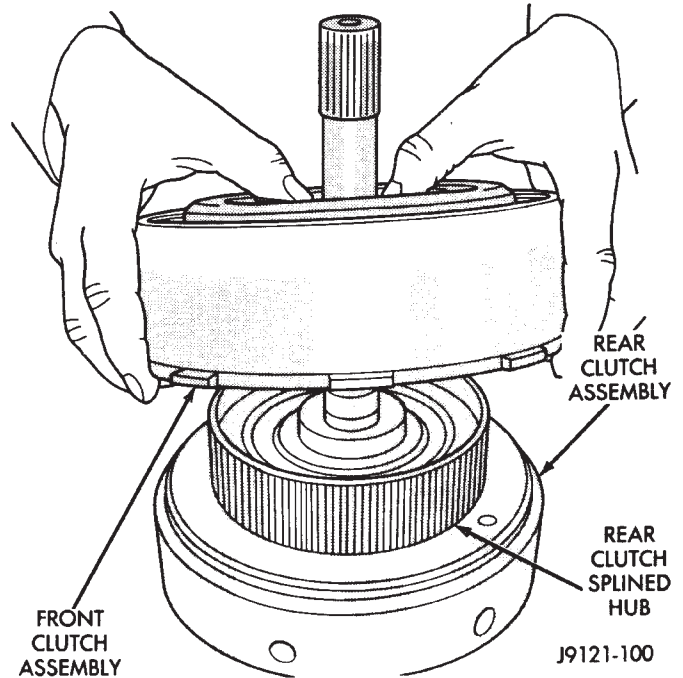


Fig. 136 Assembling Front And Rear Clutches

(12) Tighten front band adjusting screw until band is tight on clutch retainer. This will hold clutches in place while oil pump is being installed. **Verify that front/rear clutch assembly is still properly seated before tightening band.**

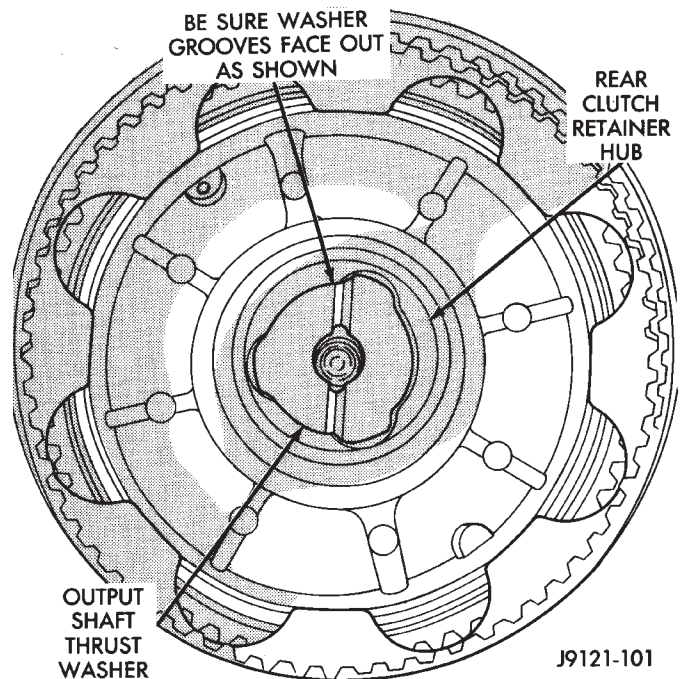


Fig. 137 Intermediate Shaft Thrust Washer

OIL PUMP

(1) Install oil pump Pilot Studs C-3288-B in case (Fig. 140).

DISASSEMBLY AND ASSEMBLY (Continued)

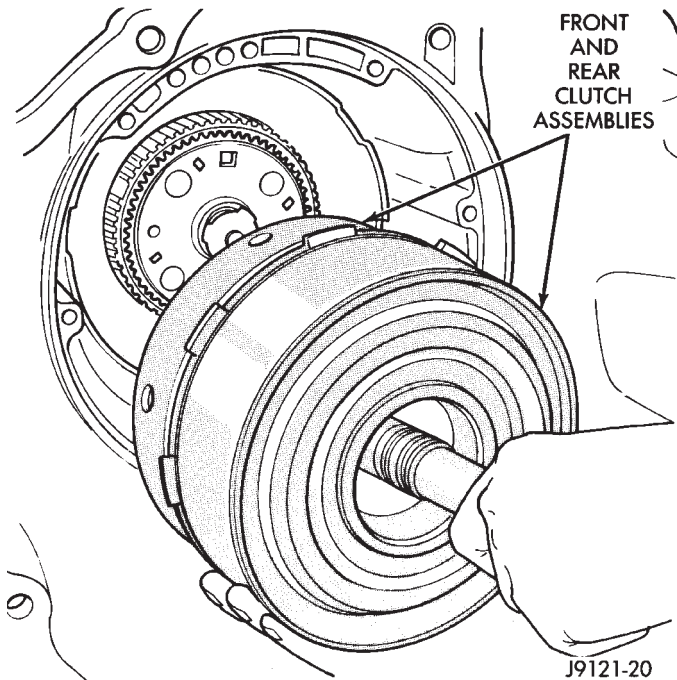


Fig. 138 Front/Rear Clutch Assemblies

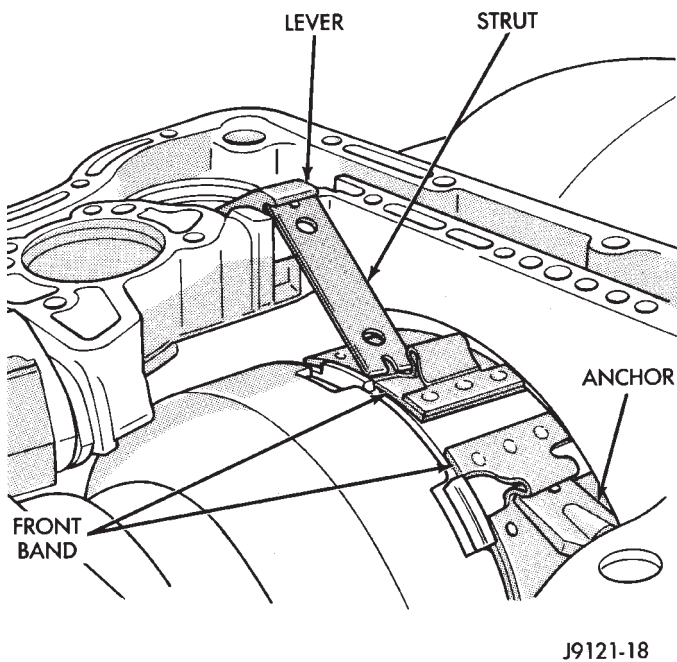


Fig. 139 Front Band And Linkage

(2) Install new oil pump gasket on pilot studs and seat it in case. Be sure gasket is properly aligned with fluid passages in case (Fig. 140).

(3) Coat front clutch thrust washer with petroleum jelly to hold it in place. Then install washer over reaction shaft hub and seat it on pump (Fig. 141).

CAUTION: The thrust washer bore (I.D.), is chamfered on one side. Make sure the chamfered side is installed so it faces the pump.

(4) Check seal rings on reaction shaft support. Be sure rings are hooked together correctly. Also be sure fiber thrust washer is in position (Fig. 142). Use extra petroleum jelly to hold washer in place if necessary.

(5) Lubricate oil pump seals with petroleum Mopar® ATF Plus 3, type 7176.

(6) Mount oil pump on pilot studs and slide pump into case opening (Fig. 143). **Work pump into case by hand. Do not use a mallet or similar tools to seat pump.**

(7) Remove pilot studs and install oil pump bolts. Tighten pump bolts alternately and evenly to fully seat pump in case. Then final-tighten pump bolts to 20 N·m (15 ft. lbs.) torque.

(8) Verify correct installation. Rotate input and intermediate shafts and check for bind. If bind exists, components are either mis-assembled, or not seated. Disassemble and correct as necessary before proceeding.

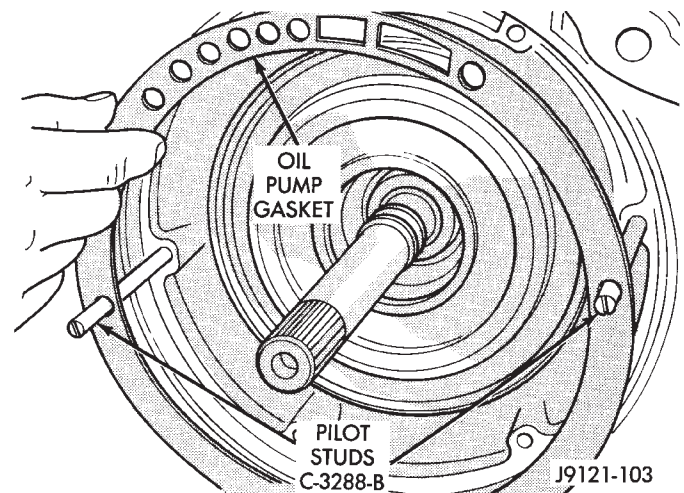


Fig. 140 Oil Pump Gasket And Pilot Studs

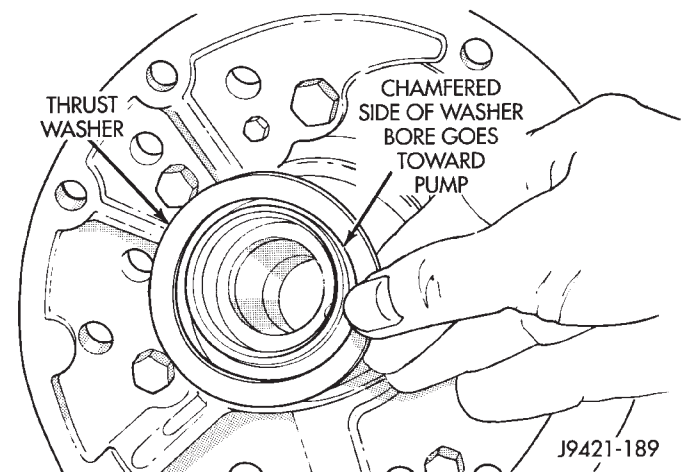


Fig. 141 Front Clutch Thrust Washer

DISASSEMBLY AND ASSEMBLY (Continued)

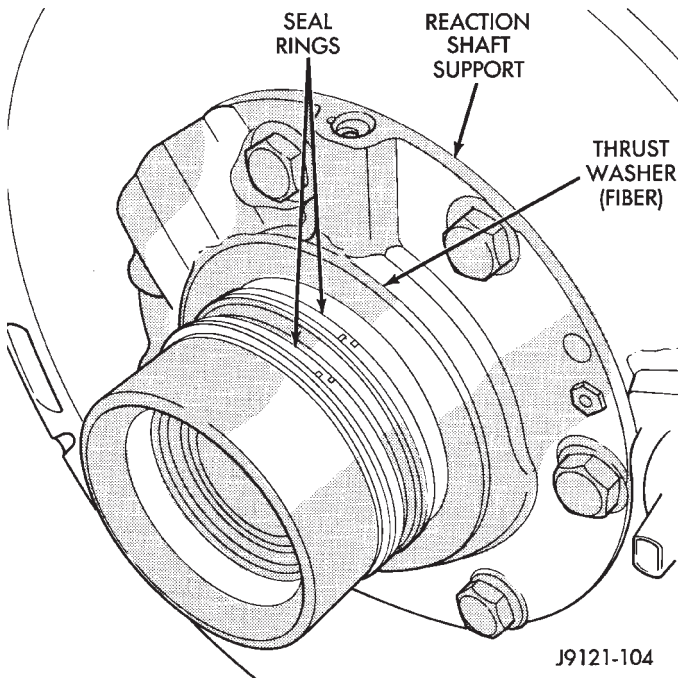


Fig. 142 Reaction Shaft Seal Ring And Thrust Washer

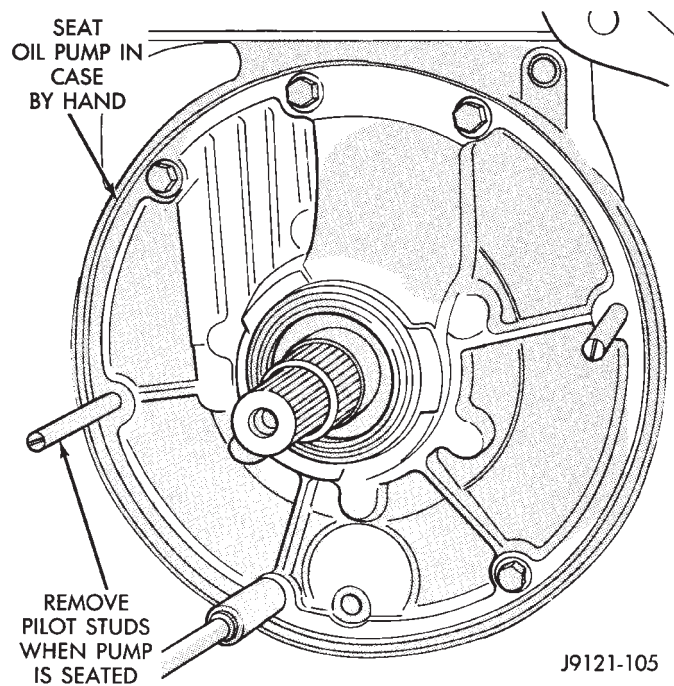


Fig. 143 Oil Pump

INPUT SHAFT END PLAY CHECK

NOTE: Overdrive unit must be installed in order to correctly measure the input shaft end-play.

- (1) Check input shaft end play as follows.
- (2) Attach dial indicator to converter housing (Fig. 144). Position indicator plunger against input shaft and zero indicator.

(3) Move input shaft in and out and record reading.

(4) End play should be 0.86 - 2.13 mm (0.034 - 0.084 in.).

(5) If end play is incorrect, change intermediate shaft thrust washer. The thrust washer controls end play and is available in three thicknesses for adjustment purposes.

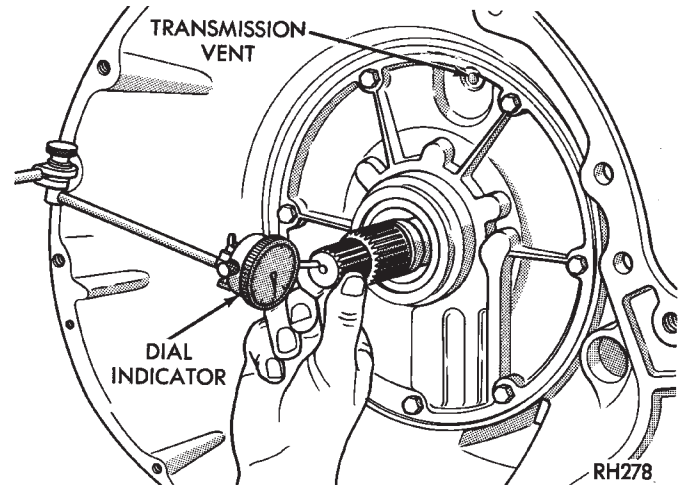


Fig. 144 Checking Input Shaft End Play

ACCUMULATOR, VALVE BODY, OIL PAN, AND TORQUE CONVERTER

(1) Install accumulator inner spring, piston and outer spring (Fig. 145).

(2) Verify that park/neutral position switch has **not** been installed in case. Valve body can not be installed if switch is in position.

(3) Install new valve body manual shaft seal in case (Fig. 146). Lubricate seal lip and manual shaft with petroleum jelly. Start seal over shaft and into case. Seat seal with 15/16 inch, deep well socket.

(4) Install valve body as follows:

(a) Start park rod into park pawl. If rod will not slide past park pawl, pawl is engaged in park gear. Rotate overdrive output shaft with suitable size 12 point socket; this will free pawl and allow rod to engage.

(b) Align and seat valve body on case. Be sure manual lever shaft and overdrive connector are fully seated in case.

(c) Install and start all valve body attaching bolts by hand. Then tighten bolts evenly, in a diagonal pattern to 12 N·m (105 in. lbs.) torque. **Do not overtighten valve body bolts. This could result in distortion and cross leakage after installation.**

(5) Install new filter on valve body. Tighten filter screws to 4 N·m (35 in. lbs.).

(6) Install seal on park/neutral position switch. Then install and tighten switch to 34 N·m (25 ft. lbs.).

DISASSEMBLY AND ASSEMBLY (Continued)

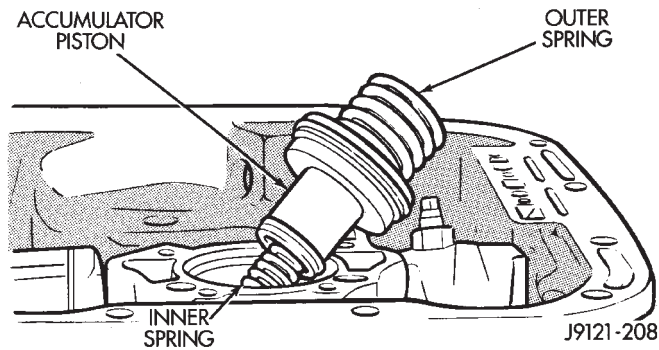


Fig. 145 Accumulator Piston And Springs

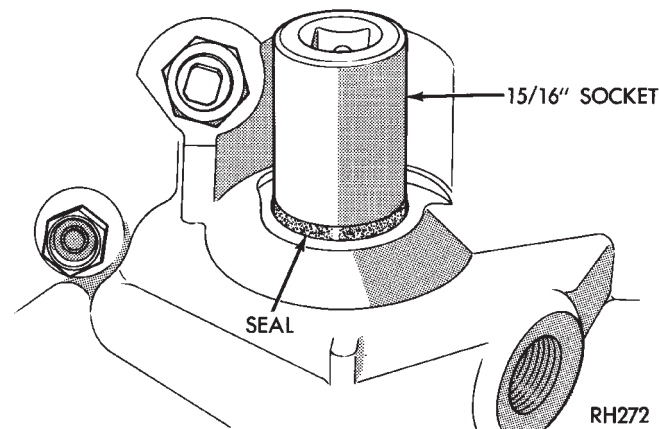


Fig. 146 Manual Lever Shaft Seal

CAUTION: If the condition of the transmission before the overhaul procedure caused excessive metallic or fiber contamination in the fluid, replace the torque converter and reverse flush the cooler(s) and cooler lines. Fluid contamination and transmission failure can result if not done.

(7) Install torque converter. Use C-clamp or metal strap to hold converter in place for installation.

BAND ADJUSTMENT AND FINAL

- (1) Adjust front and rear bands as follows:
 - (a) Loosen locknut on each band adjusting screw 4-5 turns.
 - (b) Tighten both adjusting screws to 8 N·m (72 in. lbs.).
 - (c) Back off front band adjusting screw 2-7/8 turns.
 - (d) Back off rear band adjusting screw 2 turns.
 - (e) Hold each adjusting screw in position and tighten locknut to 34 N·m (25 ft. lbs.) torque.
- (2) Install magnet in oil pan. Magnet seats on small protrusion at corner of pan.
- (3) Position new oil pan gasket on case and install oil pan. Tighten pan bolts to 17 N·m (13 ft. lbs.).
- (4) Install throttle valve and shift selector levers on valve body manual lever shaft.

(5) Apply small quantity of dielectric grease to terminal pins of solenoid case connector and neutral switch.

(6) Fill transmission with recommended fluid. Refer to Service Procedures section of this group.

(7) Road test vehicle to verify repair.

OVERRUNNING CLUTCH CAM/OVERDRIVE PISTON RETAINER

NOTE: TO SERVICE THE OVERRUNNING CLUTCH CAM AND THE OVERDRIVE PISTON RETAINER, THE TRANSMISSION GEARTRAIN AND OVERDRIVE UNIT MUST BE REMOVED FROM THE TRANSMISSION.

DISASSEMBLY

- (1) Remove the overdrive piston (Fig. 147).
- (2) Remove the overdrive piston retainer bolts.
- (3) Remove overdrive piston retainer.
- (4) Remove case gasket.
- (5) Tap old cam out of case with pin punch. Insert punch through bolt holes at rear of case (Fig. 148). Alternate position of punch to avoid cocking cam during removal.
- (6) Clean clutch cam bore and case. Be sure to remove all chips/shavings generated during cam removal.

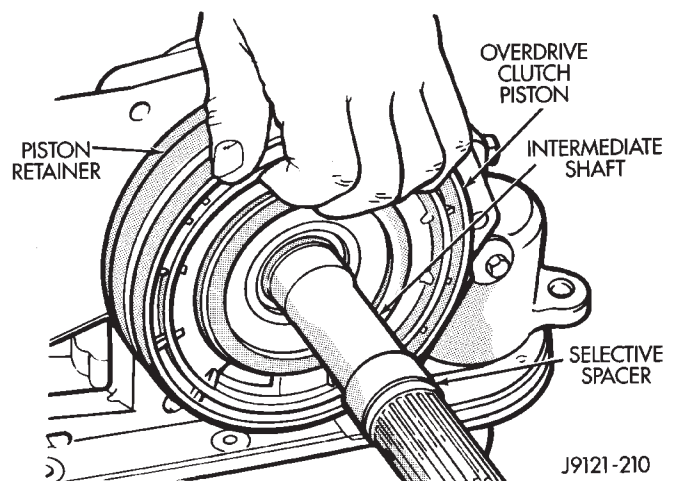


Fig. 147 Overdrive Piston Removal

ASSEMBLY

- (1) Temporarily install overdrive piston retainer in case. Use 3-4 bolts to secure retainer.
- (2) Align and start new clutch cam and spring retainer in case. Be sure serrations on cam and in case are aligned (Fig. 149). Then tap cam into case just enough to hold it in place.
- (3) **Verify that cam is correctly positioned before proceeding any further. Narrow ends of**

DISASSEMBLY AND ASSEMBLY (Continued)

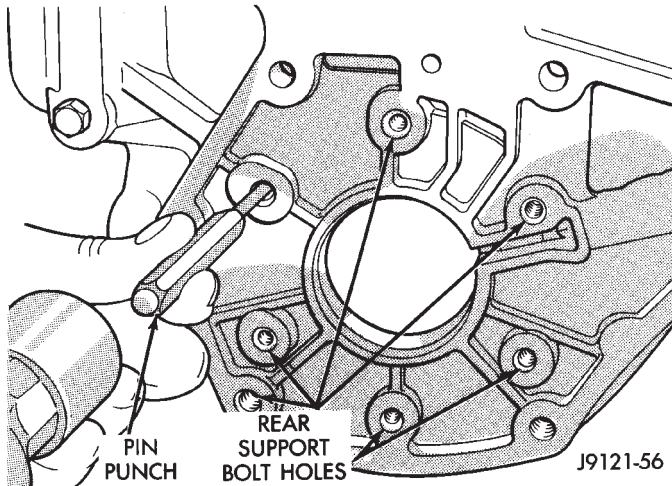


Fig. 148 Overrunning Clutch Cam

cam ramps should be to left when cam is viewed from front end of case (Fig. 149).

(4) Insert Adapter Tool SP-5124 into piston retainer (Fig. 150).

(5) Assemble Puller Bolt SP-3701 and Press Plate SP-3583-A (Fig. 151).

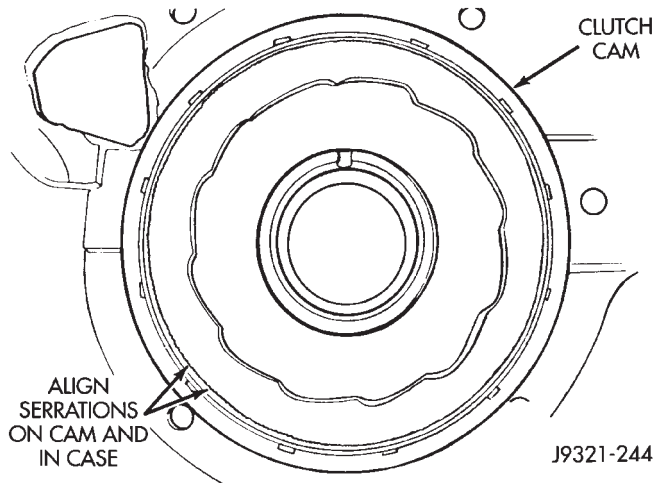


Fig. 149 Positioning Replacement Clutch Cam In Case

(6) Install assembled puller plate and bolt (Fig. 152). Insert bolt through cam, case and adapter tool. Be sure plate is seated squarely on cam.

(7) Hold puller plate and bolt in place and install puller nut SP-3701 on puller bolt (Fig. 153).

(8) Tighten puller nut to press clutch cam into case (Fig. 153). **Be sure cam is pressed into case evenly and does not become cocked.**

(9) Remove clutch cam installer tools.

(10) **Stake case in 12 places around clutch cam to help secure cam in case. Use blunt punch or chisel to stake case.**

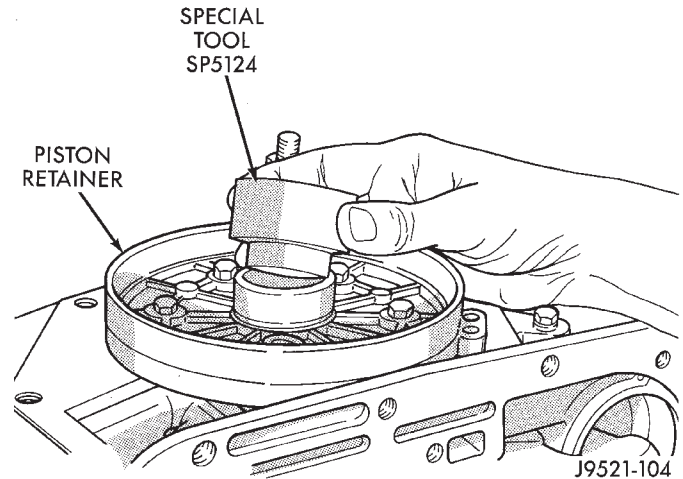


Fig. 150 Positioning Adapter Tool In Overdrive Piston Retainer

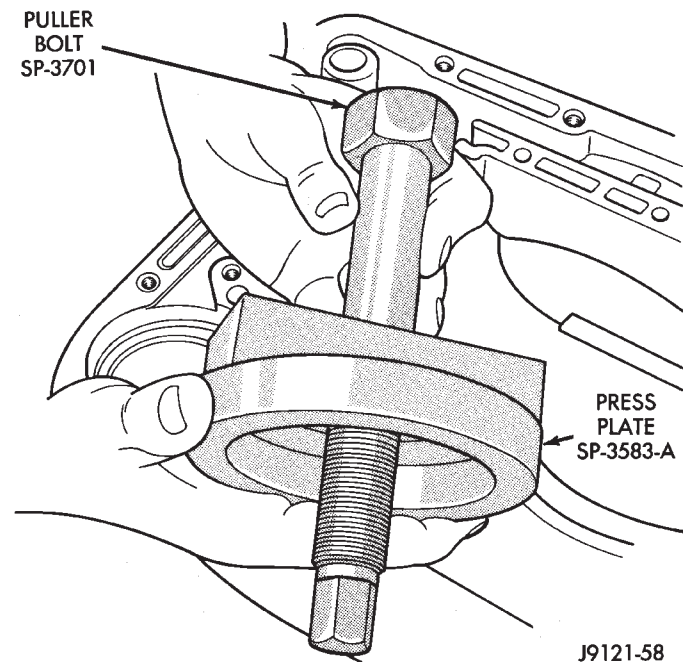


Fig. 151 Assembling Clutch Cam Puller Bolt And Press Plate

(11) Remove piston retainer from case. Cover retainer with plastic sheeting, or paper to keep it dust free.

(12) Clean case and cam thoroughly. Be sure any chips/shavings generated during cam installation are removed from case.

(13) Install new gasket at rear of transmission case. Use petroleum jelly to hold gasket in place. Be sure to align governor feed holes in gasket with feed passages in case (Fig. 154). Also install gasket before overdrive piston retainer. Center hole in gasket is smaller than retainer and cannot be installed over retainer.

DISASSEMBLY AND ASSEMBLY (Continued)

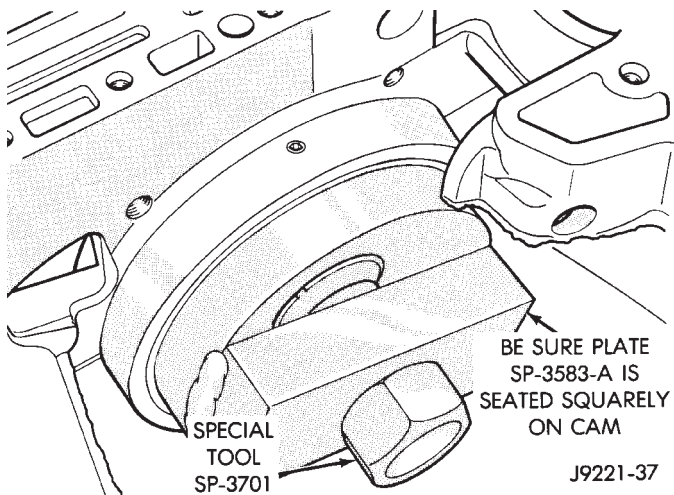


Fig. 152 Positioning Puller Plate On Clutch Cam

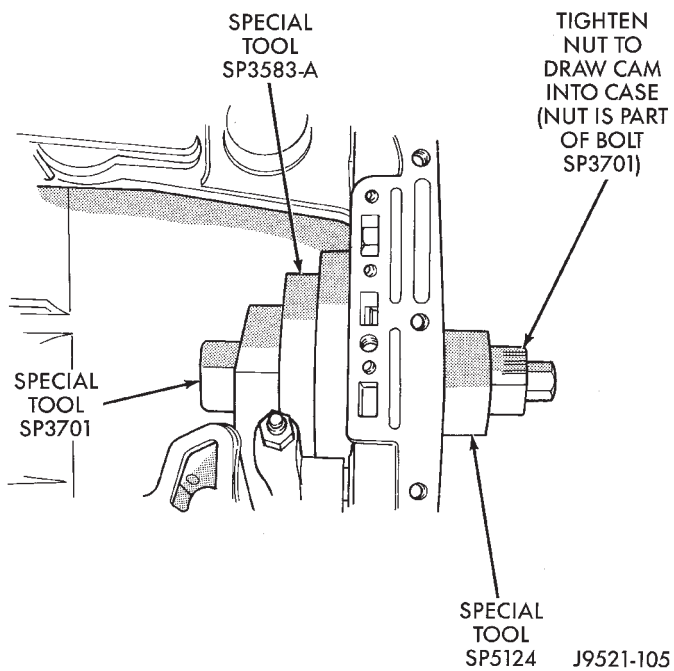


Fig. 153 Pressing Overrunning Clutch Cam Into Case

(14) Position overdrive piston retainer on transmission case and align bolt holes in retainer, gasket and case (Fig. 155). Then install and tighten retainer bolts to 17 N·m (13 ft. lbs.) torque.

(15) Install new seals on overdrive piston.

(16) Stand transmission case upright on bellhousing.

(17) Position Guide Ring 8114-1 on outer edge of overdrive piston retainer.

(18) Position Seal Guide 8114-3 on inner edge of overdrive piston retainer.

(19) Install overdrive piston in overdrive piston retainer by: aligning locating lugs on overdrive piston to the two mating holes in retainer.

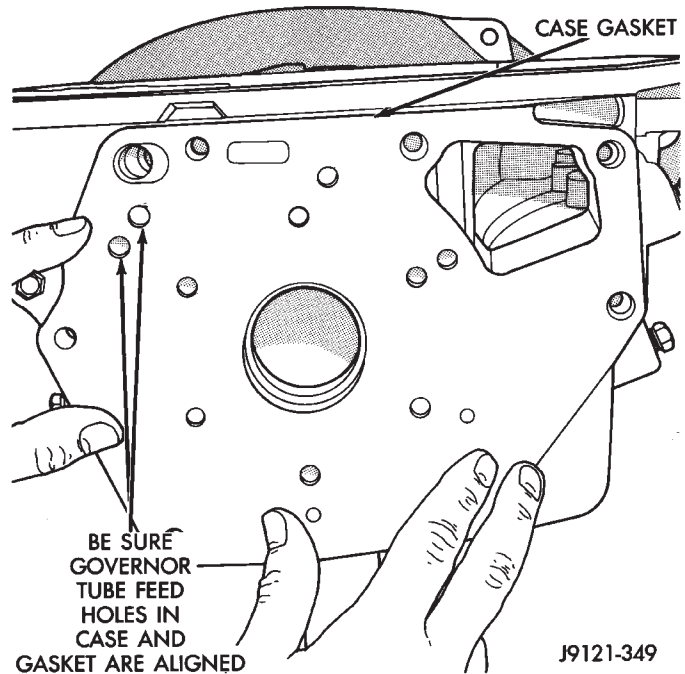


Fig. 154 Installing/Aligning Case Gasket

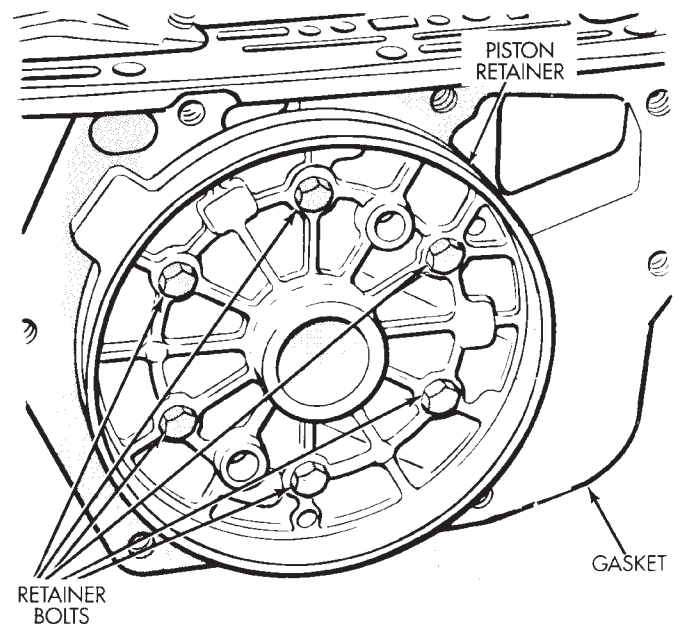


Fig. 155 Aligning Overdrive Piston Retainer

(a) Aligning locating lugs on overdrive piston to the two mating holes in retainer.

(b) Lubricate overdrive piston seals with Mopar® Door Ease, or equivalent.

(c) Install piston over Seal Guide 8114-3 and inside Guide Ring 8114-1.

(d) Push overdrive piston into position in retainer.

DISASSEMBLY AND ASSEMBLY (Continued)

(e) Verify that the locating lugs entered the lug bores in the retainer.

NOTE: INSTALL THE REMAINING TRANSMISSION COMPONENTS AND OVERDRIVE UNIT.

FRONT SERVO PISTON**DISASSEMBLY**

- (1) Remove seal ring from rod guide (Fig. 156).
- (2) Remove small snap ring from servo piston rod. Then remove piston rod, spring and washer from piston.
- (3) Remove and discard servo component O-ring and seal rings.

ASSEMBLY

Clean and inspect front servo components.

- (1) Lubricate new O-ring and seal rings with petroleum jelly and install them on piston, guide and rod.
- (2) Install rod in piston. Install spring and washer on rod. Compress spring and install snap ring (Fig. 156).

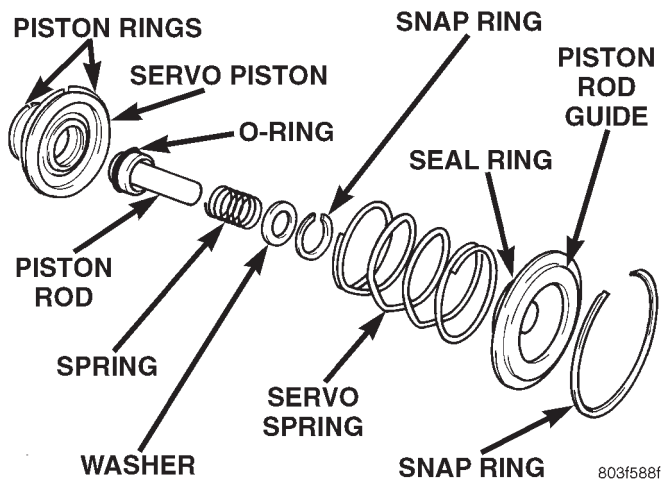


Fig. 156 Front Servo

REAR SERVO PISTON**DISASSEMBLY**

- (1) Remove small snap ring and remove plug and spring from servo piston (Fig. 157).
- (2) Remove and discard servo piston seal ring.

ASSEMBLY

- (1) Lubricate piston and guide seals with petroleum jelly. Lubricate other servo parts with Mopar® ATF Plus 3, Type 7176, transmission fluid.
- (2) Install new seal ring on servo piston.
- (3) Assemble piston, plug, spring and new snap ring.
- (4) Lubricate piston seal lip with petroleum jelly.

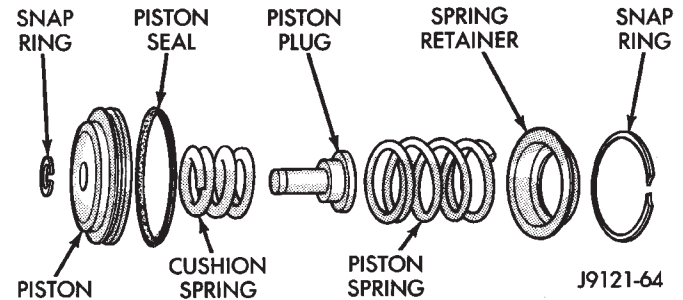
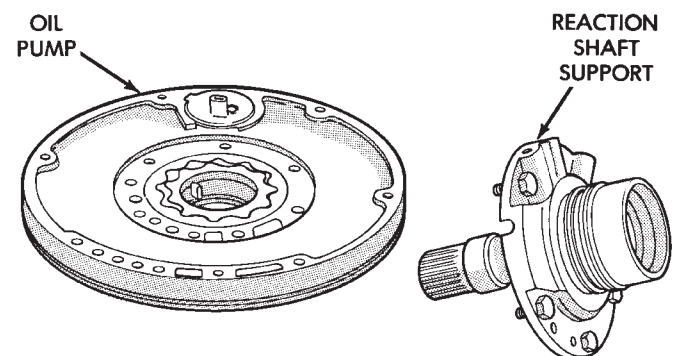


Fig. 157 Rear Servo Components

OIL PUMP AND REACTION SHAFT SUPPORT**DISASSEMBLY**

- (1) Mark position of support in oil pump body for assembly alignment reference. Use scribe or paint to make alignment marks.
- (2) Place pump body on two wood blocks.
- (3) Remove reaction shaft support bolts and separate support from pump body (Fig. 158).
- (4) Remove pump inner and outer gears (Fig. 159).
- (5) Remove O-ring seal from pump body (Fig. 160). Discard seal after removal.
- (6) Remove oil pump seal with Remover Tool C-3981. Discard seal after removal.



J9321-176

Fig. 158 Reaction Shaft Support

OIL PUMP BUSHING REMOVAL

- (1) Position pump housing on clean, smooth surface with gear cavity facing down.
- (2) Remove bushing with Tool Handle C-4171 and Bushing Remover SP-3550 (Fig. 161).

REACTION SHAFT SUPPORT BUSHING REMOVAL

- (1) Assemble Cup Tool SP-3633, Nut SP-1191 and Bushing Remover SP-5301 (Fig. 163).

DISASSEMBLY AND ASSEMBLY (Continued)

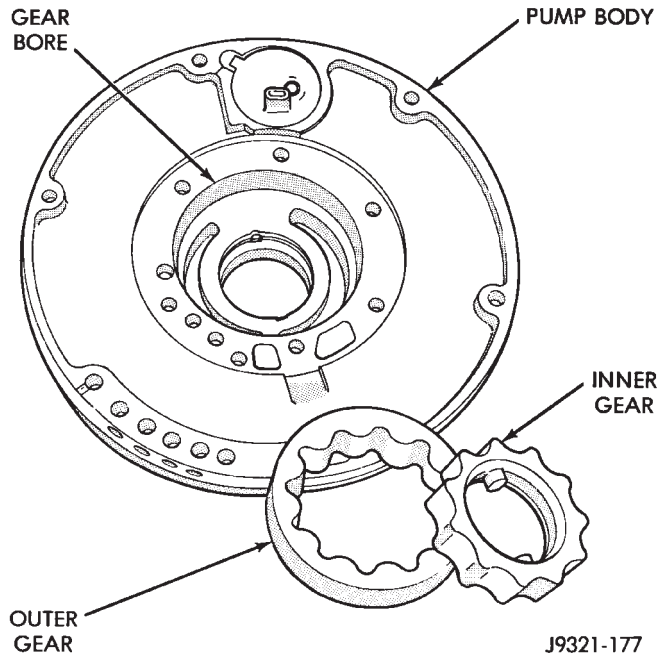


Fig. 159 Pump Gear

(2) Hold cup tool firmly against reaction shaft. Thread remover tool into bushing as far as possible by hand.

(3) Using wrench, thread remover tool an additional 3-4 turns into bushing to firmly engage tool.
 (4) Tighten tool hex nut against cup tool to pull bushing from shaft. Clean all chips from shaft and support after bushing removal.

ASSEMBLY

OIL PUMP BUSHING INSTALLATION

(1) Assemble Tool Handle C-4171 and Bushing Installer SP-5118.
 (2) Place bushing on installer tool and start bushing into shaft.
 (3) Tap bushing into place until Installer Tool SP-5118 bottoms in pump cavity. Keep tool and bushing square with bore. Do not allow bushing to become cocked during installation.
 (4) Stake pump bushing in two places with blunt punch. Remove burrs from stake points with knife blade (Fig. 162).

REACTION SHAFT SUPPORT BUSHING INSTALLATION

(1) Place reaction shaft support upright on a clean, smooth surface.

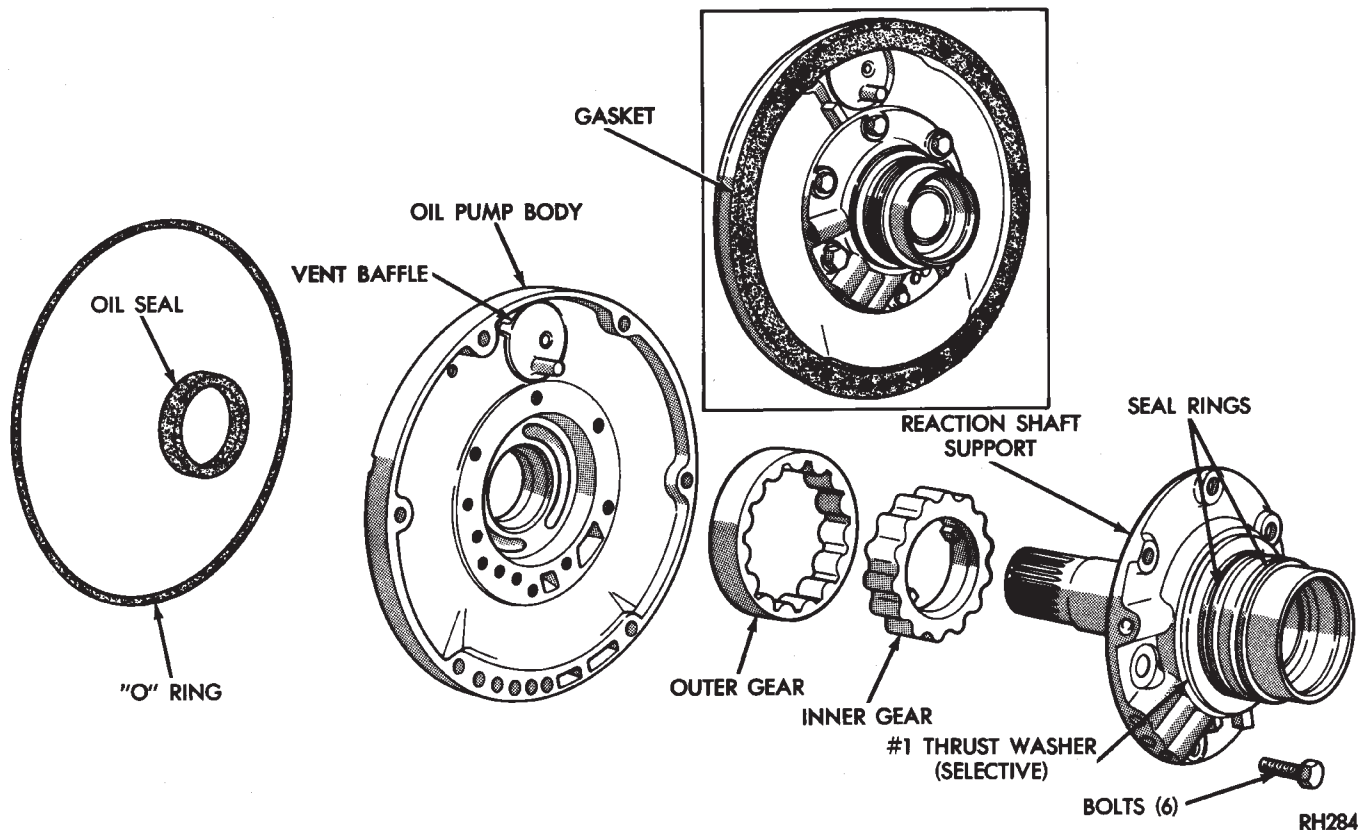
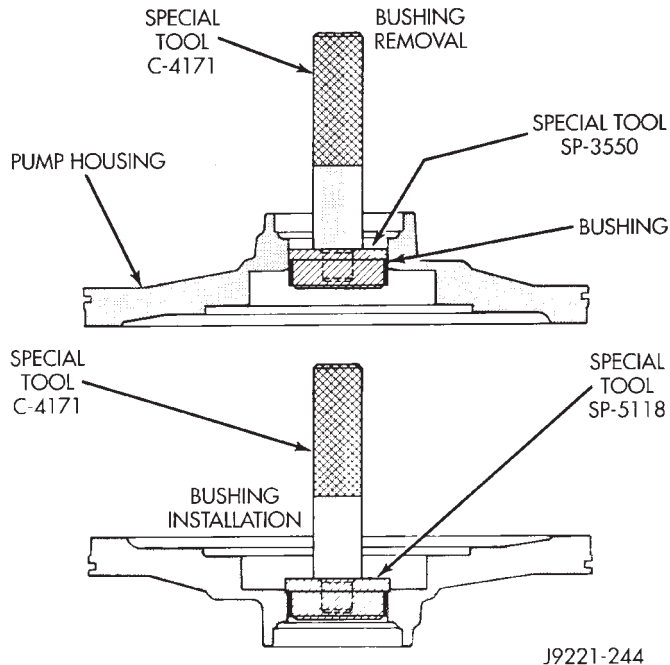
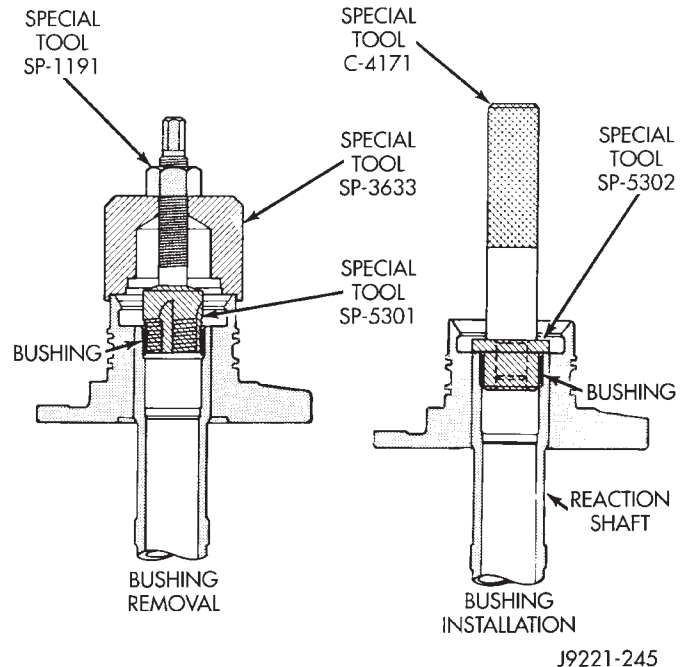
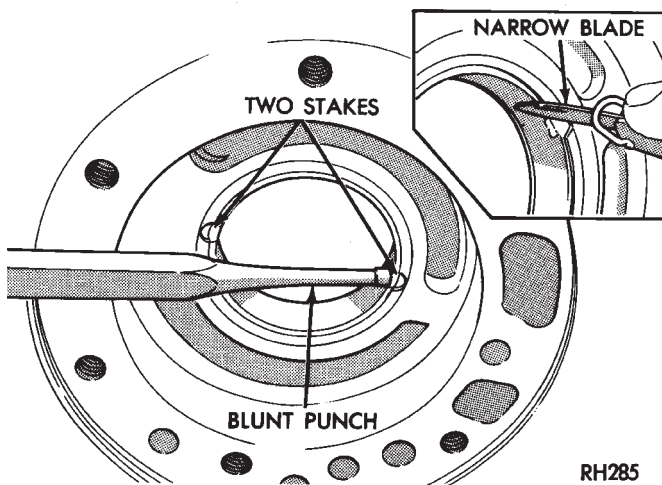


Fig. 160 Oil Pump And Reaction Shaft Components

DISASSEMBLY AND ASSEMBLY (Continued)**Fig. 161 Oil Pump Bushing****Fig. 163 Reaction Shaft Bushing****Fig. 162 Staking-Deburring Oil Pump Bushing**

(2) Assemble Bushing Installer Tools C-4171 and SP-5302. Then slide new bushing onto installer tool (Fig. 163).

(3) Start bushing in shaft. Tap bushing into shaft until installer tool bottoms against support flange.

(4) Clean reaction shaft support thoroughly after bushing replacement (to remove any chips).

(1) Lubricate pump gears with transmission fluid and install them in pump body.

(2) Install thrust washer on reaction shaft support hub. Lubricate washer with petroleum jelly or transmission fluid before installation.

(3) If reaction shaft seal rings are being replaced, install new seal rings on support hub. Lubricate seal rings with transmission fluid or petroleum jelly after

installation. Squeeze each ring until ring ends are securely hooked together.

CAUTION: The reaction shaft support seal rings will break if overspread, or twisted. If new rings are being installed, spread them only enough for installation. Also be very sure the ring ends are securely hooked together after installation. Otherwise, the rings will either prevent pump installation, or break during installation.

(4) Align and install reaction shaft support on pump body.

(5) Install bolts attaching reaction shaft support to pump. Tighten bolts to 20 N·m (175 in. lbs.) torque.

(6) Install new pump seal with Installer Tool C-3860-A (Fig. 164). Use hammer or mallet to tap seal into place.

(7) Install new O-ring on pump body. Lubricate oil seal and O-ring with petroleum jelly.

(8) Cover pump assembly to prevent dust entry and set aside for assembly installation.

FRONT CLUTCH**DISASSEMBLY**

(1) Remove waved snap ring and remove reaction plate, clutch plates and clutch discs.

(2) Compress clutch piston retainer and piston springs with Compressor Tool C-3863-A (Fig. 165).

(3) Remove retainer snap ring and remove compressor tool.

DISASSEMBLY AND ASSEMBLY (Continued)

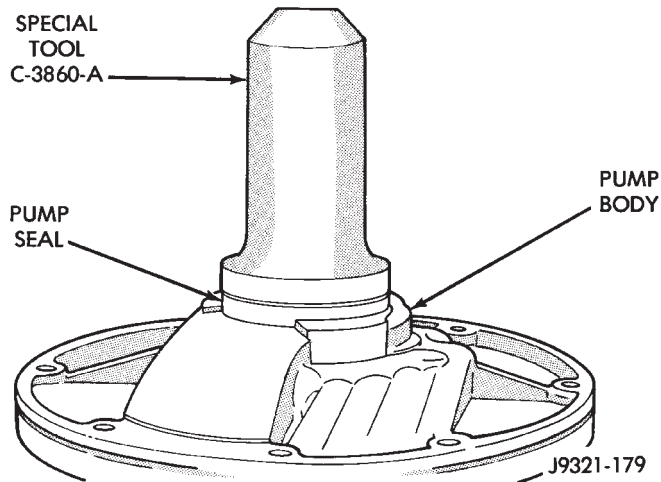


Fig. 164 Oil Pump Seal

(4) Remove clutch piston springs (Fig. 166). **Note position of piston springs for assembly reference.**

(5) Remove clutch piston from retainer with a twisting motion.

(6) Remove and discard clutch piston inner and outer seals.

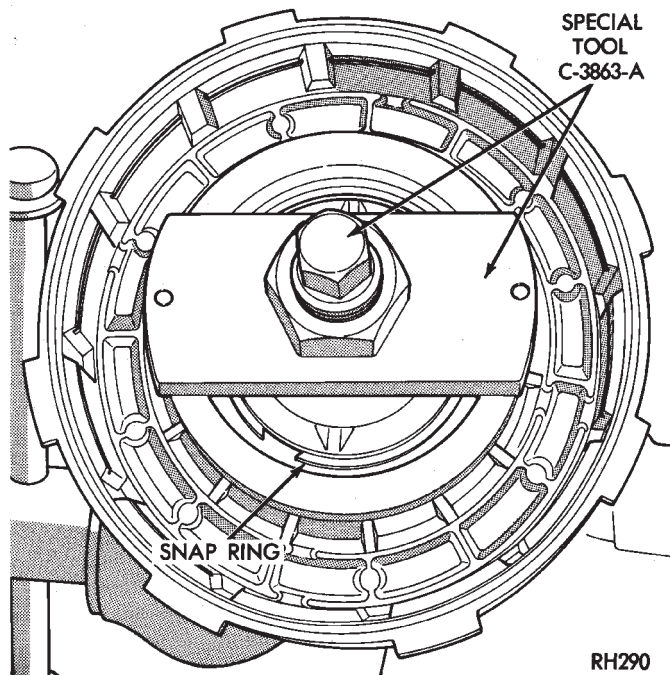


Fig. 165 Removing Front Clutch Spring Retainer Snap Ring

(7) Assemble Tool Handle C-4171 and Bushing Remover SP-3629 (Fig. 167).

(8) Insert remover tool in bushing and drive bushing straight out of clutch retainer.

ASSEMBLY

(1) Mount Bushing Installer SP-5511 on tool handle (Fig. 167).

(2) Slide new bushing onto installer tool and start bushing into retainer.

(3) Tap new bushing into place until installer tool bottoms against clutch retainer.

(4) Remove installer tools and clean retainer thoroughly.

(5) Soak clutch discs in transmission fluid.

(6) Install new inner and outer seals on clutch piston. Be sure seal lips face interior of retainer.

(7) Lubricate new inner and outer piston seals with Ru-Glyde, or Mopar® Door Ease.

(8) Install clutch piston in retainer. Use twisting motion to seat piston in bottom of retainer. A thin strip of plastic (about 0.015 - 0.020 in. thick), can be used to guide seals into place if necessary.

CAUTION: Never push the clutch piston straight in. This will fold the seals over causing leakage and clutch slip. In addition, never use any type of metal tool to help ease the piston seals into place. Metal tools will cut, shave, or score the seals.

(9) Install and position nine clutch piston springs (Fig. 168).

(10) Install spring retainer on top of piston springs.

(11) Compress spring retainer and piston springs with Tool C-3863-A.

(12) Install spring retainer snap ring and remove compressor tool.

(13) Install clutch plates and discs (Fig. 166). Three clutch discs, three steel plates and one reaction plate are required.

(14) Install reaction plate followed by waved snap ring.

(15) Check clutch pack clearance with feeler gauge (Fig. 169). Clearance between waved spring and pressure plate should 1.78 - 3.28 mm (0.070 - 0.129 in.). If clearance is incorrect, clutch plates, clutch discs, snap ring, or pressure plate may have to be changed.

REAR CLUTCH

DISASSEMBLY

(1) Remove clutch pack select fit snap ring.

(2) Remove reaction plate and remove clutch plates and discs (Fig. 170).

(3) Remove pressure plate, wave spring, spacer ring and piston spring from clutch retainer.

(4) Remove clutch piston from piston retainer with a twisting motion.

(5) Remove input shaft thrust washer, if washer remained in piston retainer hub during removal.

DISASSEMBLY AND ASSEMBLY (Continued)

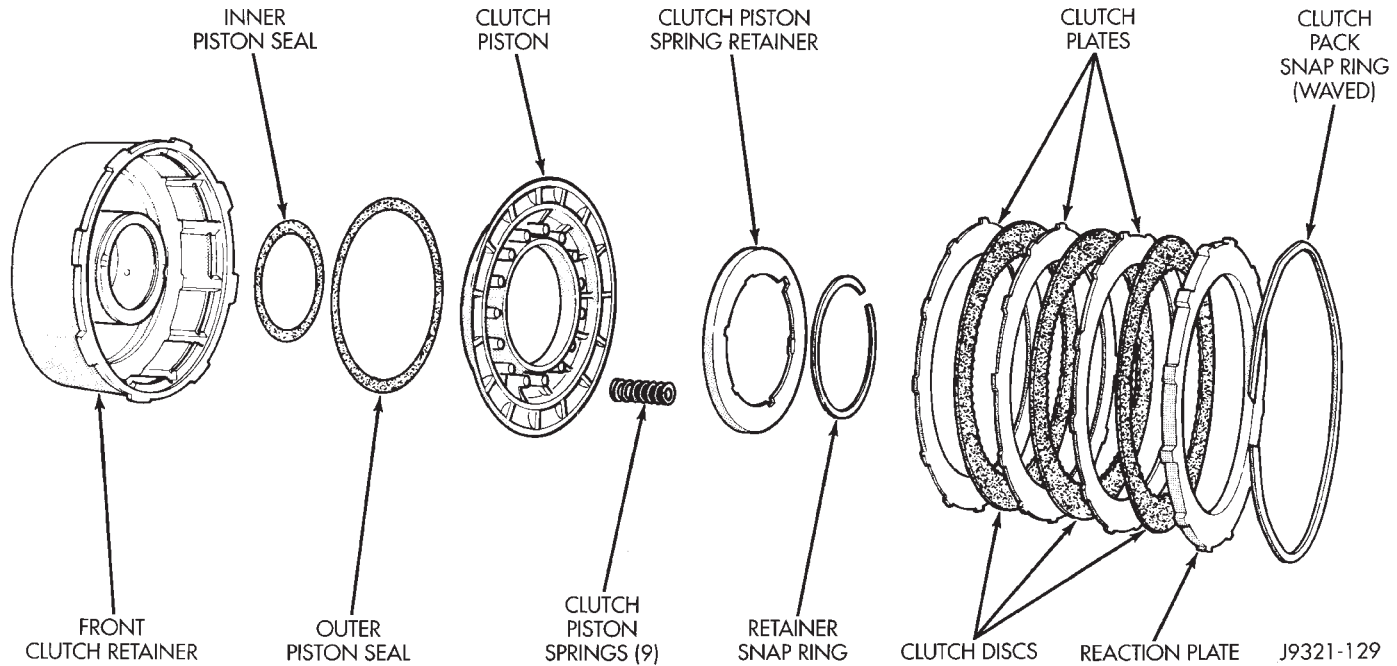


Fig. 166 Front Clutch Components

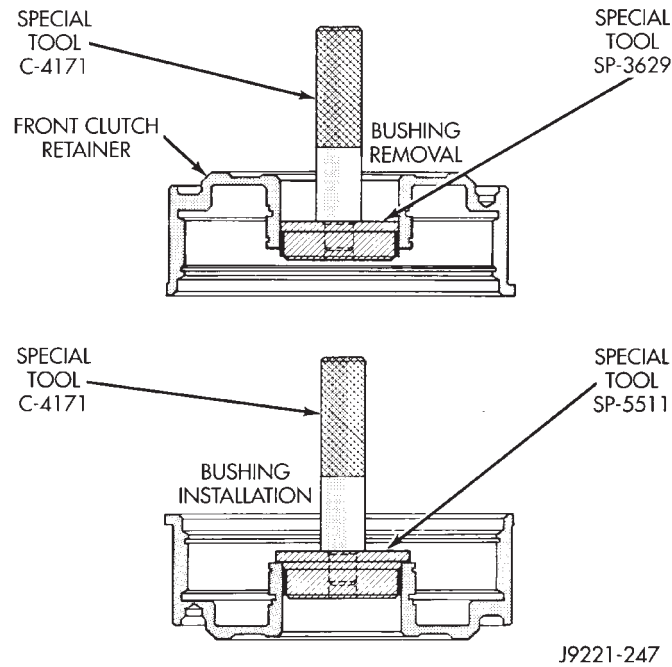


Fig. 167 Front Clutch Retainer Bushing Replacement Tools

(6) Remove seals from clutch piston. Discard seals after removal.

If the input shaft must be replaced, first remove the retaining ring that secures the shaft in the piston retainer hub. Then press the old shaft out of the retainer with a shop press using suitable press tools to press on the shaft and to support the retainer hub as close to the shaft as possible.

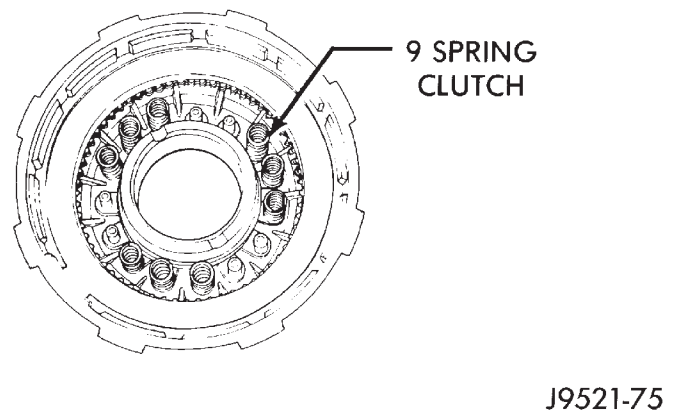


Fig. 168 Front Clutch Spring Position

ASSEMBLY

(1) Lubricate the splines of the new shaft with petroleum jelly or Mopar® ATF Plus 3, type 7176. Then align the shaft in the piston retainer and carefully press it into place using suitable press tools to press the shaft and to support the retainer hub as close to the shaft as possible. Do not allow the shaft to become cocked during installation. The retainer can be cracked if misalignment occurs.

(2) Install the shaft retaining ring after pressing the shaft into place. Be sure the ring is fully seated before proceeding with clutch assembly.

(3) Invert the input shaft in the press and using the same tools as in removal, press on shaft enough to seat the snap-ring into the retainer.

(4) Soak clutch discs in transmission fluid before assembly.

DISASSEMBLY AND ASSEMBLY (Continued)

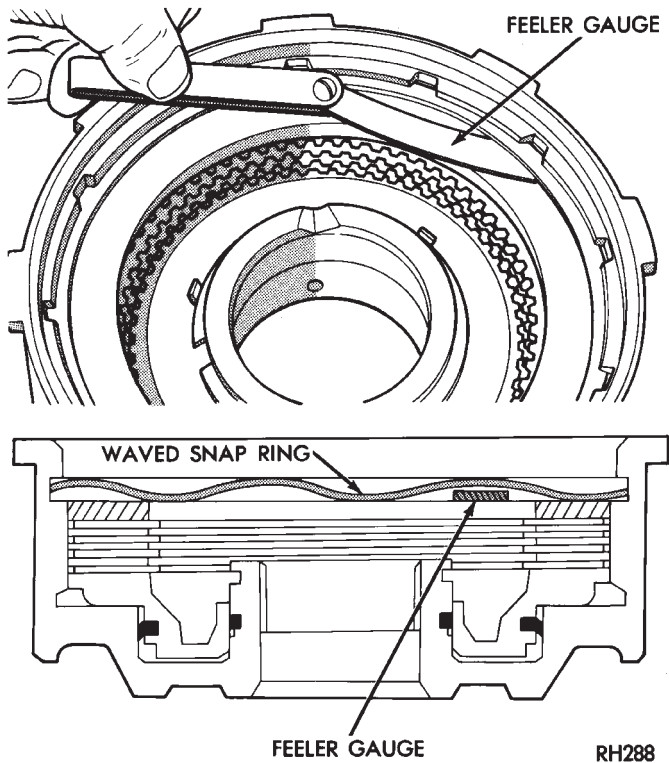


Fig. 169 Typical Method Of Measuring Front Clutch Pack Clearance

(5) Install new seals on clutch piston. Lubricate piston seals with Mopar® Door Ease, or Ru-Glyde to ease installation. **Be sure seal lips face input shaft.**

(6) Install clutch piston in retainer. Use twisting motion to seat piston in bottom of retainer. A thin

strip of plastic (about 0.020" thick), can be used to guide seals into place if necessary.

CAUTION: Never push the clutch piston straight in. This will fold the seals over causing leakage and clutch slip. In addition, never use any type of metal tool to help ease the piston seals into place. Metal tools will cut, shave, or score the seals.

(7) Assemble piston retainer and clutch retainer.
 (8) Support clutch retainer with wood blocks, or insert input shaft through pre-drilled hole in work-bench. Clutch pack components are easier to install if retainers are properly supported.

(9) Install piston spring in clutch retainer. Concave side of spring faces upward and away from clutch piston.

(10) Install spacer ring on top of piston spring.
 (11) Install wave spring on top of spacer ring. Then seat wave spring in retainer groove. **If wave spring will not seat properly, spacer ring has probably shifted over and into wave spring groove in retainer. Use small screwdriver to realign spacer ring if necessary.**

(12) Install inner pressure plate in clutch retainer.
 (13) Install first clutch disc followed by steel plate until all discs and plates are installed. 4 clutch discs and steel plates are required (Fig. 170).

(14) Install reaction plate on top of last clutch disc.
 (15) Install selective snap ring to secure clutch pack in retainer.

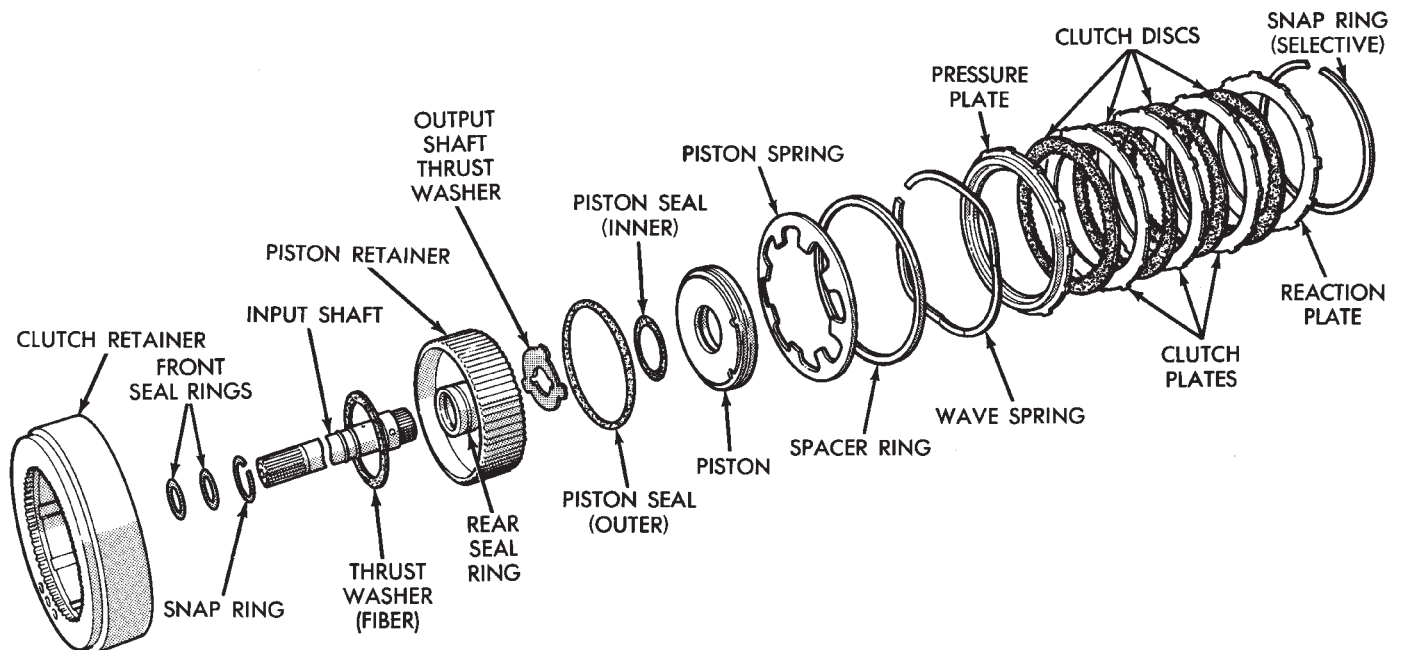


Fig. 170 Rear Clutch Components

DISASSEMBLY AND ASSEMBLY (Continued)

(16) Install new seal rings on input shaft if necessary (Fig. 171). Be very sure ring ends are all securely hooked together before proceeding.

(17) Check clutch pack clearance with feeler gauge (Fig. 172). Clearance should be 0.63 to 1.14 mm (0.025 to 0.045 in.).

(18) If clutch pack clearance is incorrect, clutch pack snap ring, may have to be replaced.

(19) Install thrust washer on piston retainer hub. Use petroleum jelly to hold thrust washer in place.

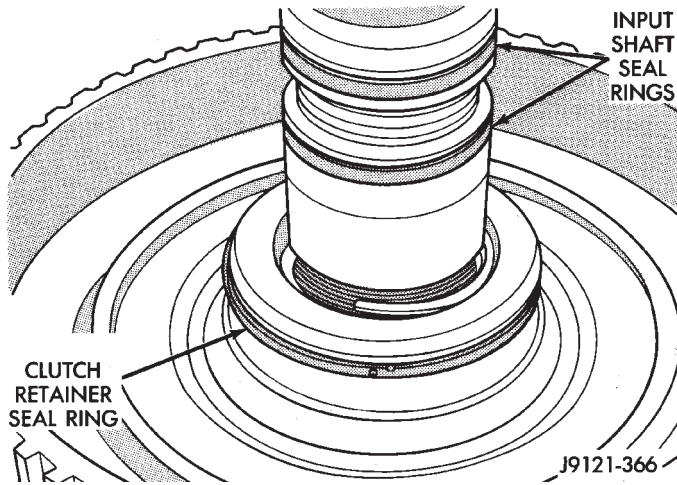


Fig. 171 Input Shaft Seal Ring Locations

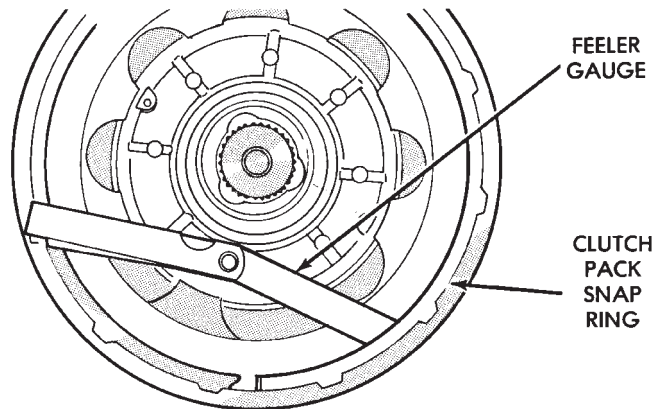


Fig. 172 Measuring Rear Clutch Pack Clearance

PLANETARY GEARTRAIN/OUTPUT SHAFT

DISASSEMBLY

(1) Remove planetary snap ring from intermediate shaft (Fig. 173). Discard snap ring as it is not reusable.

(2) Remove front planetary gear and front annulus gear as assembly (Fig. 174).

(3) Remove front planetary gear and thrust washer from front annulus gear (Fig. 175). Note thrust washer position for assembly reference.

(4) Remove tabbed thrust washer from driving shell (Fig. 176). Note washer position for assembly reference.

(5) Remove sun gear and driving shell as assembly (Fig. 177).

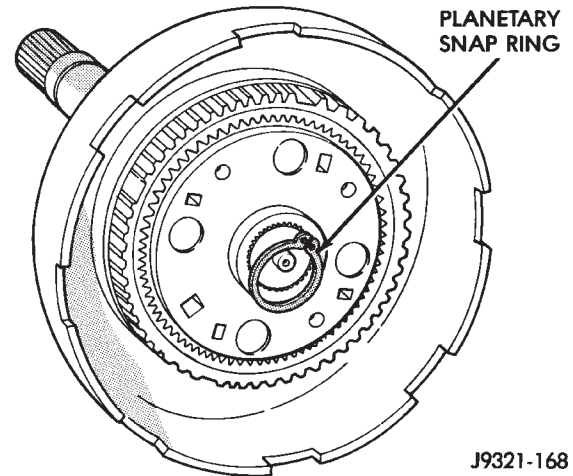


Fig. 173 Removing Planetary Snap Ring

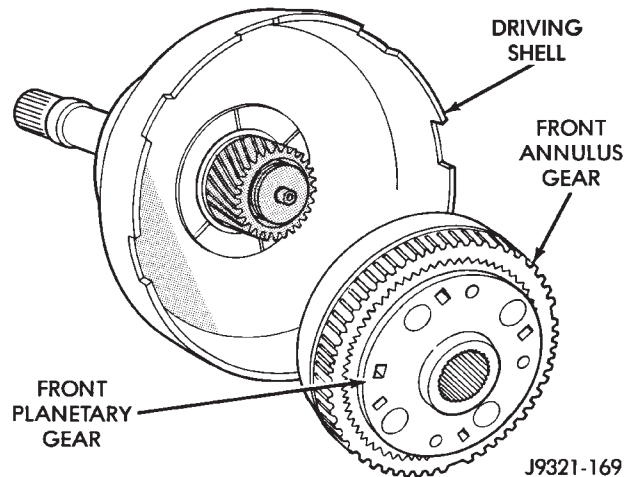
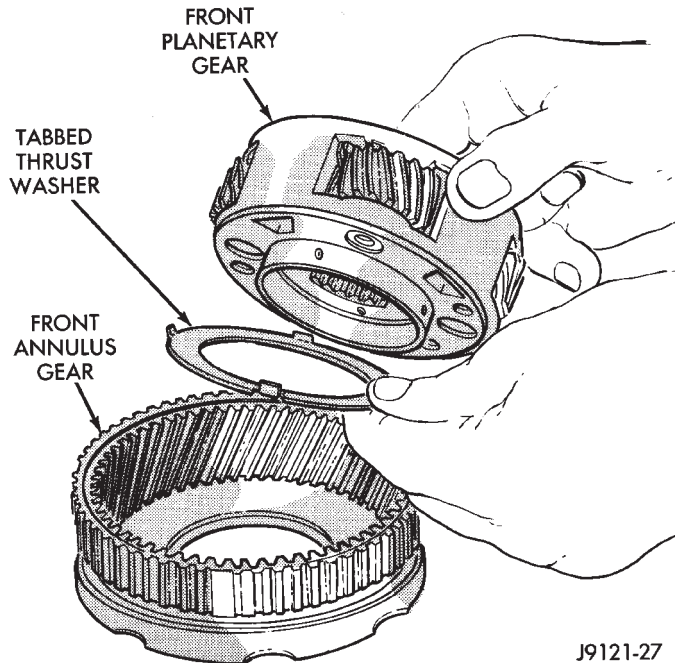


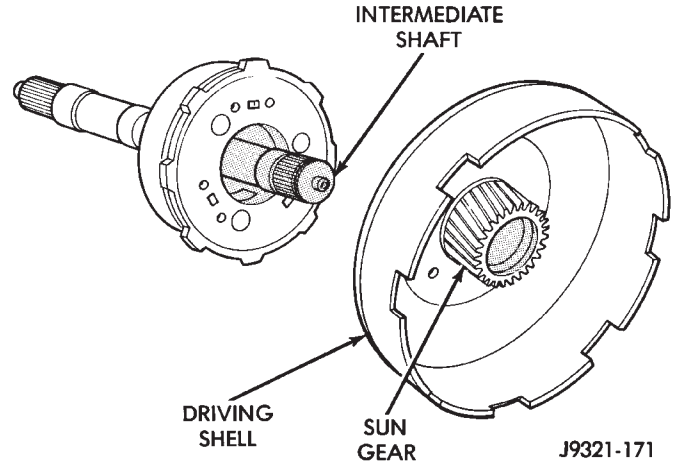
Fig. 174 Removing Front Planetary And Annulus Gears

DISASSEMBLY AND ASSEMBLY (Continued)



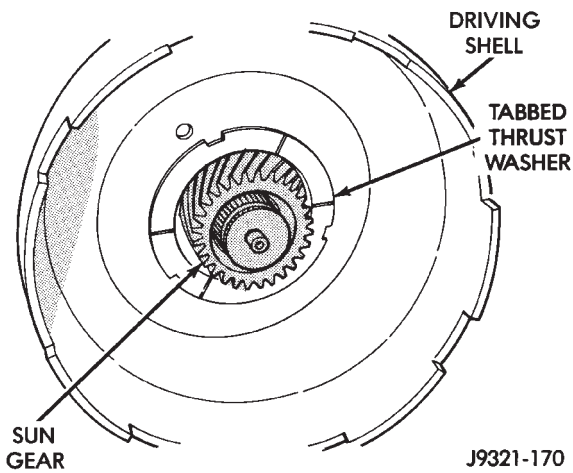
J9121-27

Fig. 175 Disassembling Front Planetary And Annulus Gears



J9321-171

Fig. 177 Sun Gear And Driving Shell Removal



J9321-170

Fig. 176 Driving Shell Thrust Washer Removal

(6) Remove tabbed thrust washer from rear planetary gear (Fig. 178). Note washer position on gear for assembly reference.

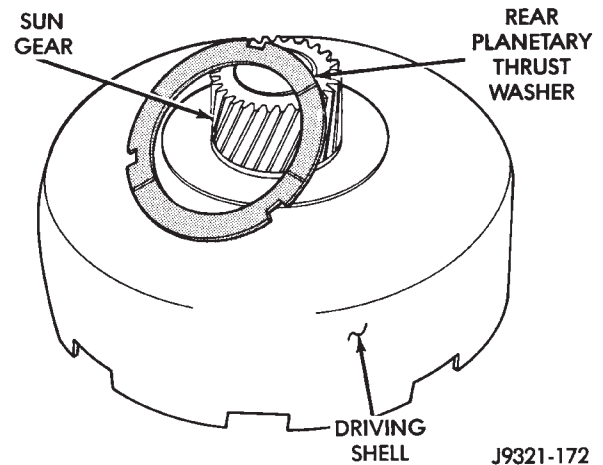
(7) Remove rear planetary gear and rear annulus gear from intermediate shaft (Fig. 179).

(8) Remove thrust plate from rear annulus gear (Fig. 180).

ASSEMBLY

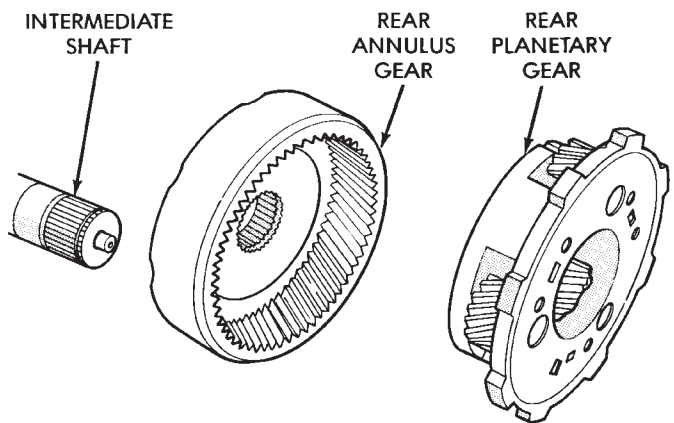
(1) Lubricate sun gear and planetary gears with transmission fluid during assembly. Use petroleum jelly to lubricate intermediate shaft bushing surfaces, thrust washers and thrust plates and to hold these parts in place during assembly.

(2) Install front snap ring on sun gear and install gear in driving shell. Then install thrust plate over



J9321-172

Fig. 178 Rear Planetary Thrust Washer Removal



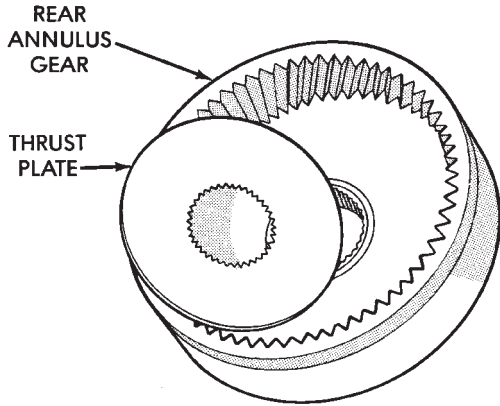
J9321-173

Fig. 179 Rear Planetary And Annulus Gear Removal

sun gear and against rear side of driving shell (Fig. 181). Install rear snap ring to secure sun gear and thrust plate in driving shell.

(3) Install rear annulus gear on intermediate shaft (Fig. 182).

DISASSEMBLY AND ASSEMBLY (Continued)

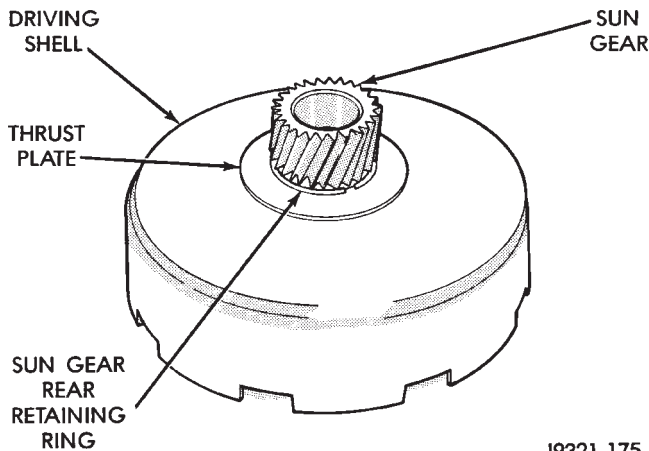


J9321-174

Fig. 180 Rear Annulus Thrust Plate Removal

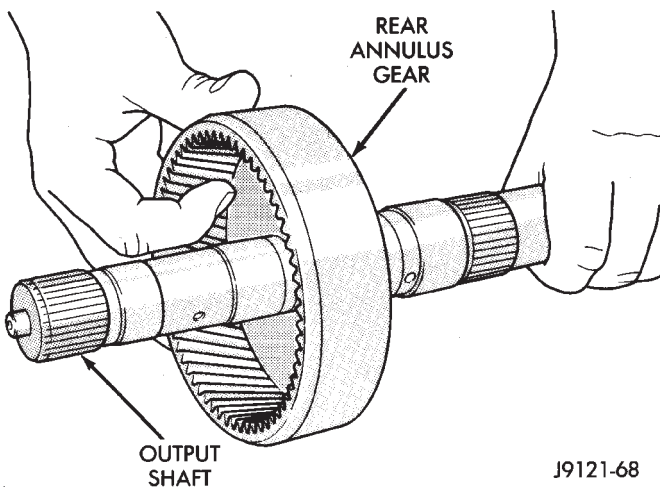
(4) Install thrust plate in annulus gear (Fig. 183). Be sure plate is seated on shaft splines and against gear.

(5) Install rear planetary gear in rear annulus gear (Fig. 184). Be sure planetary carrier is seated against annulus gear.



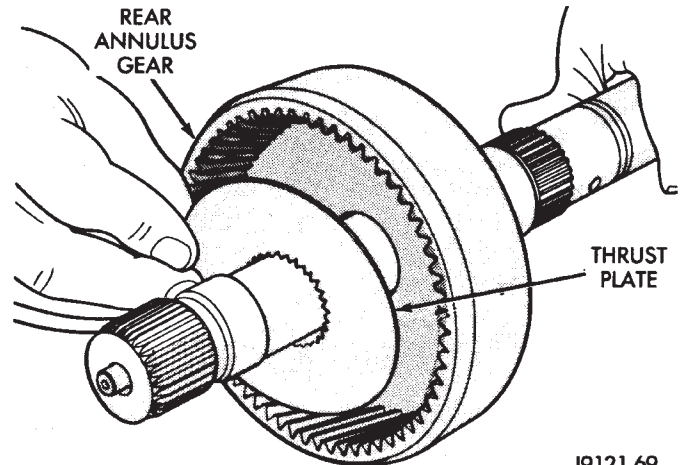
J9321-175

Fig. 181 Sun Gear Installation



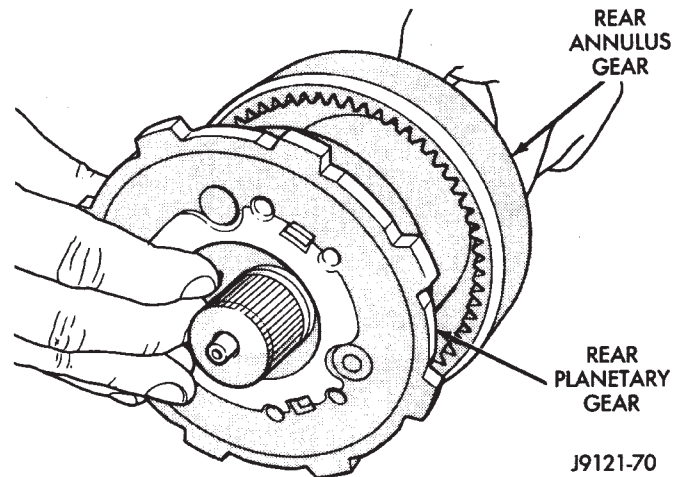
J9121-68

Fig. 182 Installing Rear Annulus Gear On Intermediate Shaft



J9121-69

Fig. 183 Installing Rear Annulus Thrust Plate

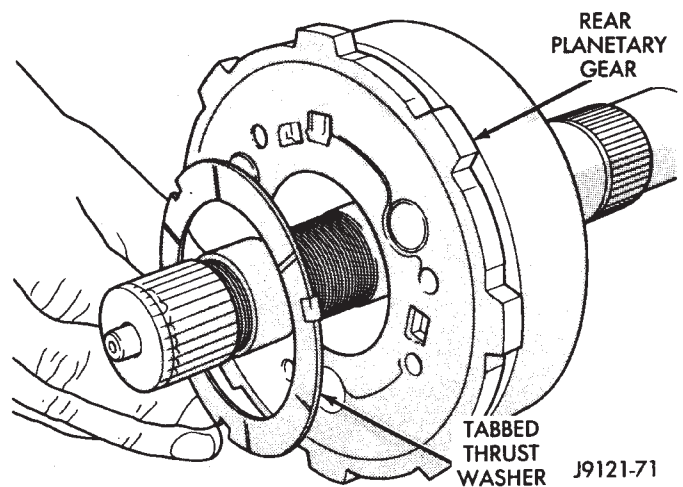


J9121-70

Fig. 184 Installing Rear Planetary Gear

(6) Install tabbed thrust washer on front face of rear planetary gear (Fig. 185). Seat washer tabs in matching slots in face of gear carrier. Use extra petroleum jelly to hold washer in place if desired.

(7) Lubricate sun gear bushings with petroleum jelly or transmission fluid.



J9121-71

Fig. 185 Installing Rear Planetary Thrust Washer

DISASSEMBLY AND ASSEMBLY (Continued)

(8) Install sun gear and driving shell on intermediate shaft (Fig. 186). Seat shell against rear planetary gear. Verify that thrust washer on planetary gear was not displaced during installation.

(9) Install tabbed thrust washer in driving shell (Fig. 187), be sure washer tabs are seated in tab slots of driving shell. Use extra petroleum jelly to hold washer in place if desired.

(10) Install tabbed thrust washer on front planetary gear (Fig. 188). Seat washer tabs in matching slots in face of gear carrier. Use extra petroleum jelly to hold washer in place if desired.

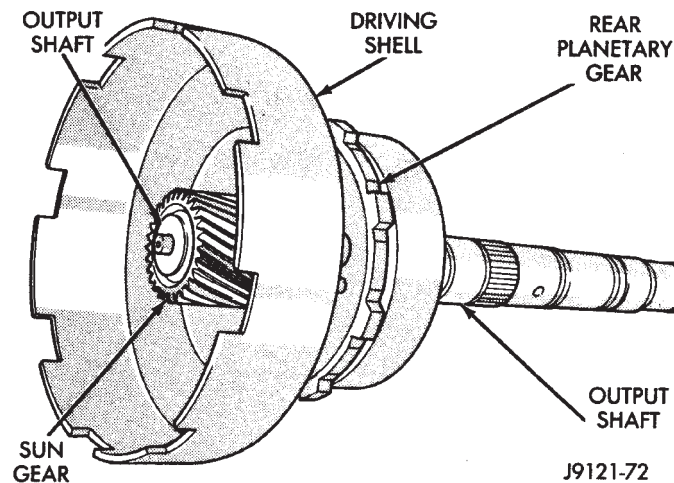


Fig. 186 Installing Sun Gear And Driving Shell

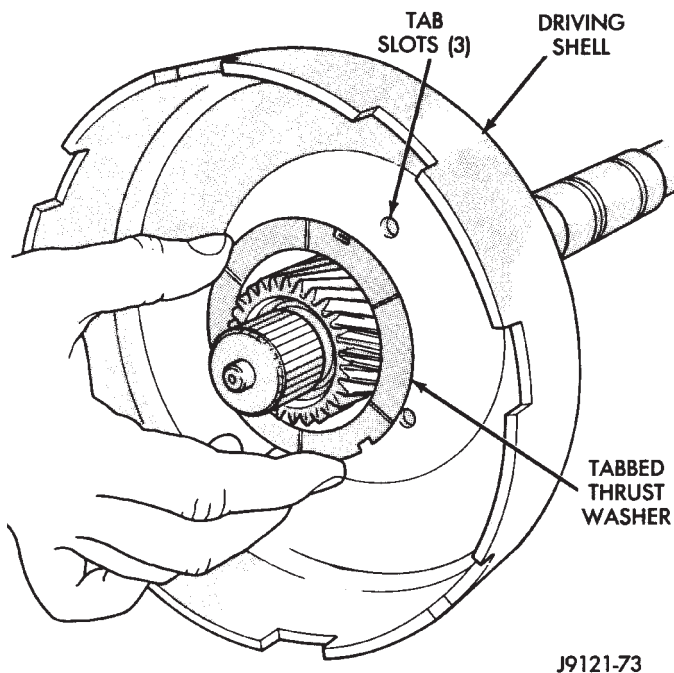


Fig. 187 Installing Driving Shell Thrust Washer

(11) Install front annulus gear over and onto front planetary gear (Fig. 189). Be sure gears are fully meshed and seated.

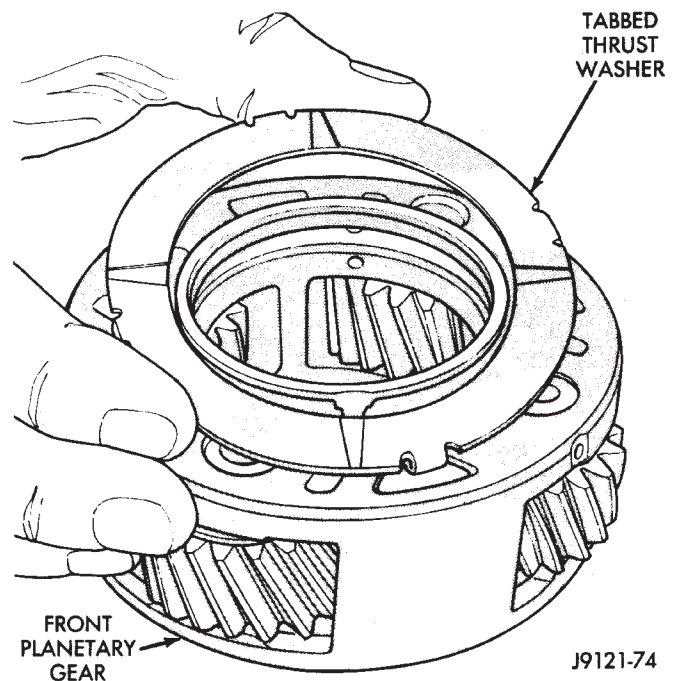


Fig. 188 Installing Thrust Washer On Front Planetary Gear

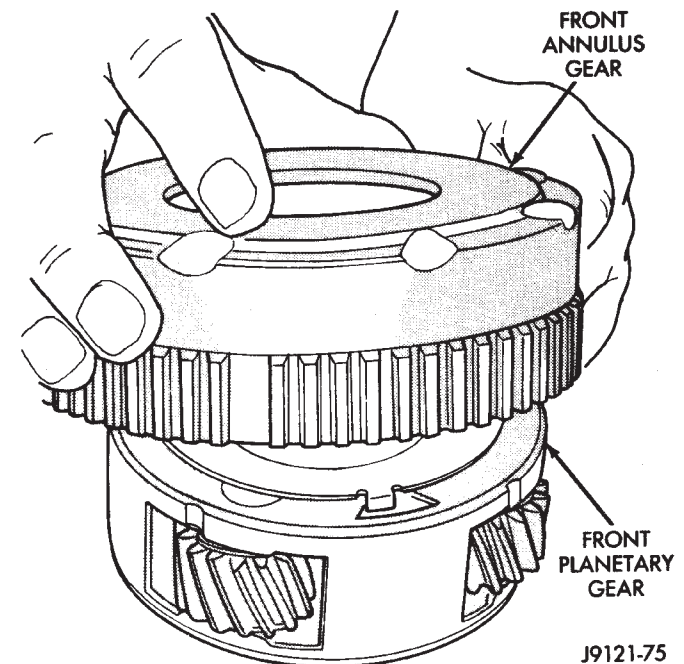


Fig. 189 Assembling Front Planetary And Annulus Gears

(12) Install front planetary and annulus gear assembly (Fig. 190). Hold gears together and slide them onto shaft. Be sure planetary pinions are seated on sun gear and that planetary carrier is seated on intermediate shaft.

(13) Place geartrain in upright position. Rotate gears to be sure all components are seated and prop-

DISASSEMBLY AND ASSEMBLY (Continued)

erly assembled. Snap ring groove at forward end of intermediate shaft will be completely exposed when components are assembled correctly.

(14) Install new planetary snap ring in groove at end of intermediate shaft (Fig. 191).

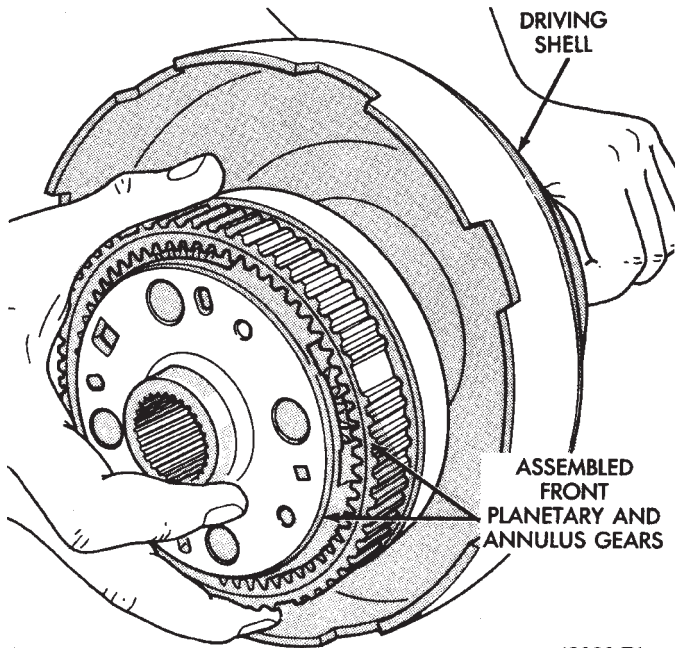


Fig. 190 Installing Front Planetary And Annulus Gear Assembly

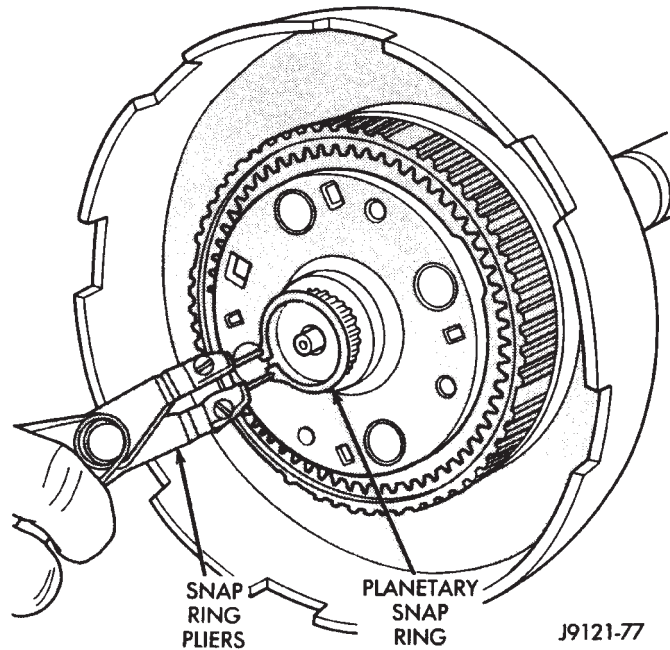


Fig. 191 Installing Planetary Snap Ring

(15) Turn planetary geartrain over. Position wood block under front end of intermediate shaft and support geartrain on shaft. Be sure all geartrain parts

have moved forward against planetary snap ring. This is important for accurate end play check.

(16) Check planetary geartrain end play with feeler gauge (Fig. 192). Insert gauge between rear annulus gear and shoulder on intermediate shaft as shown. End play should be 0.15 to 1.22 mm (0.006 to 0.048 in.).

(17) If end play is incorrect, install thinner/thicker planetary snap ring as needed.

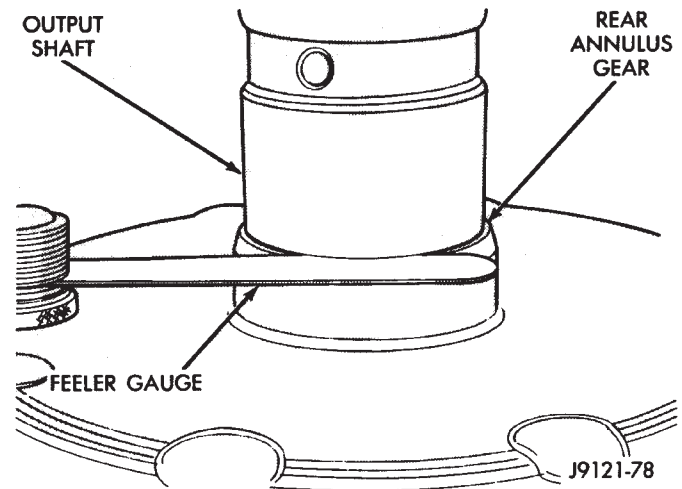


Fig. 192 Checking Planetary Geartrain End Play OVERDRIVE UNIT

DISASSEMBLY

(1) Remove transmission speed sensor and O-ring seal from overdrive case (Fig. 193).

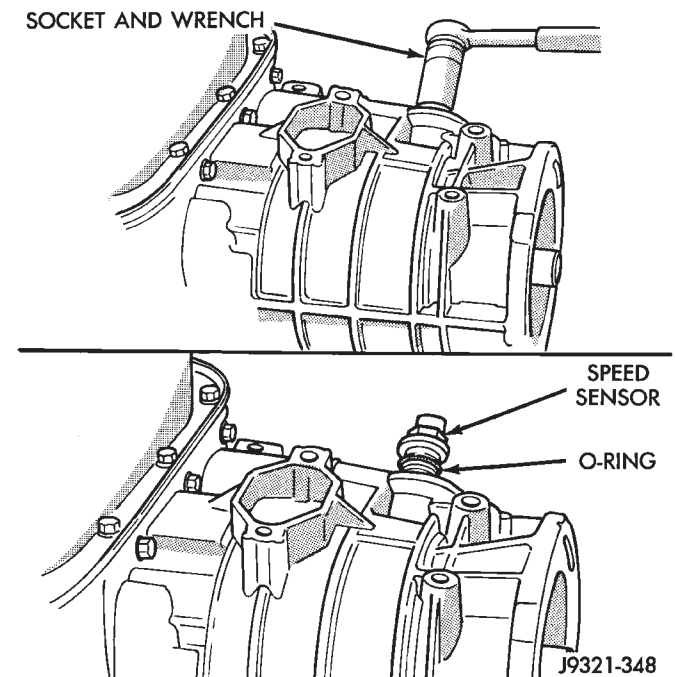


Fig. 193 Transmission Speed Sensor Removal/Installation

DISASSEMBLY AND ASSEMBLY (Continued)

(2) Remove overdrive piston thrust bearing (Fig. 194).

OVERDRIVE PISTON

(1) Remove overdrive piston thrust plate (Fig. 195). Retain thrust plate. It is a select fit part and may possibly be reused.

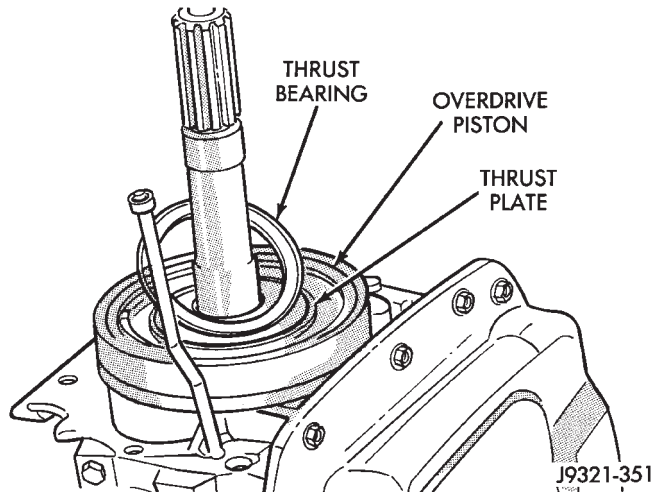


Fig. 194 Overdrive Piston Thrust Bearing Removal/ Installation

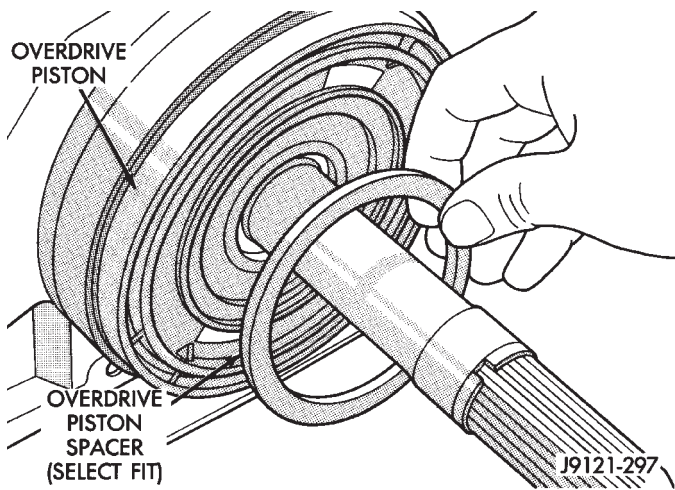


Fig. 195 Overdrive Piston Thrust Plate Removal/ Installation

(2) Remove intermediate shaft spacer (Fig. 196). Retain spacer. It is a select fit part and may possibly be reused.

(3) Remove overdrive piston from retainer (Fig. 197).

OVERDRIVE CLUTCH PACK

(1) Remove overdrive clutch pack wire retaining ring (Fig. 198).

(2) Remove overdrive clutch pack (Fig. 199).

(3) Note position of clutch pack components for assembly reference (Fig. 200).

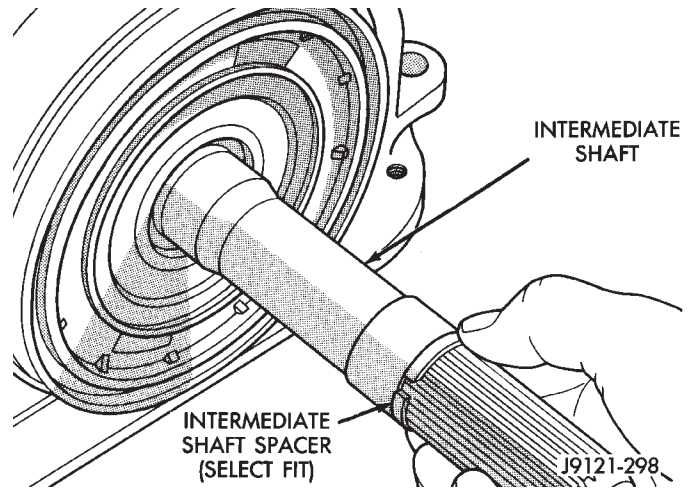


Fig. 196 Intermediate Shaft Spacer Location

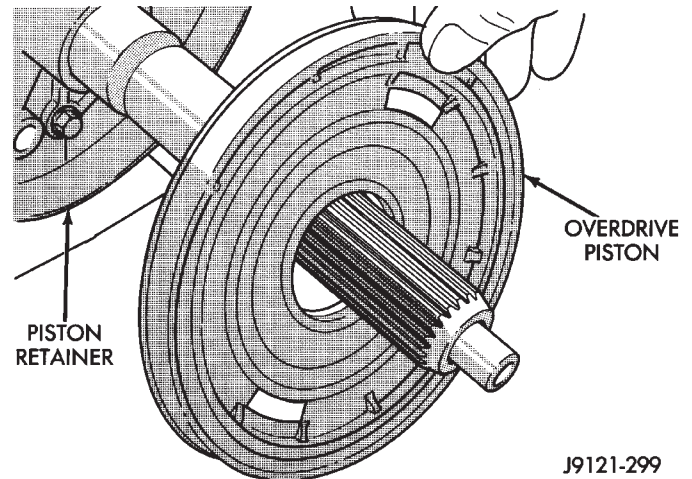


Fig. 197 Overdrive Piston Removal

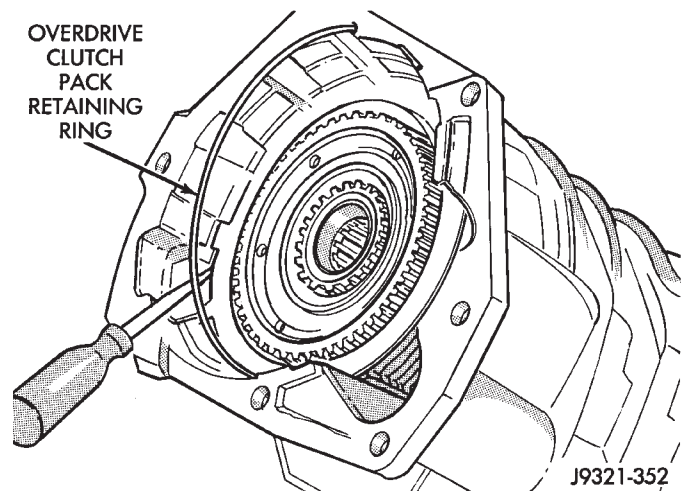


Fig. 198 Removing Overdrive Clutch Pack Retaining Ring

DISASSEMBLY AND ASSEMBLY (Continued)

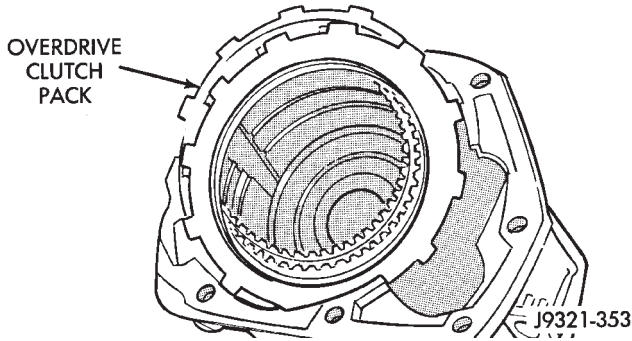


Fig. 199 Overdrive Clutch Pack Removal

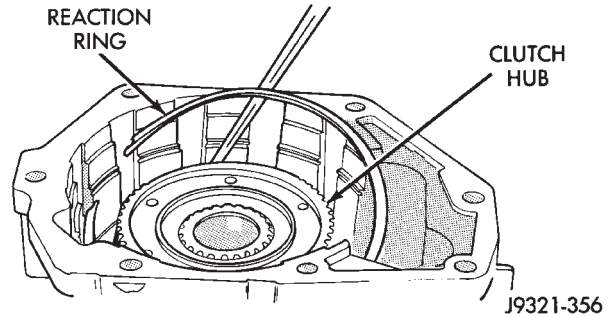


Fig. 202 Overdrive Clutch Reaction Snap Ring Removal/Installation

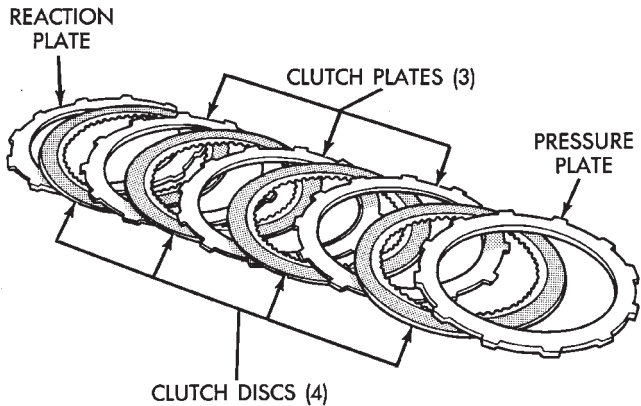


Fig. 200 46RE Overdrive Clutch Component Position

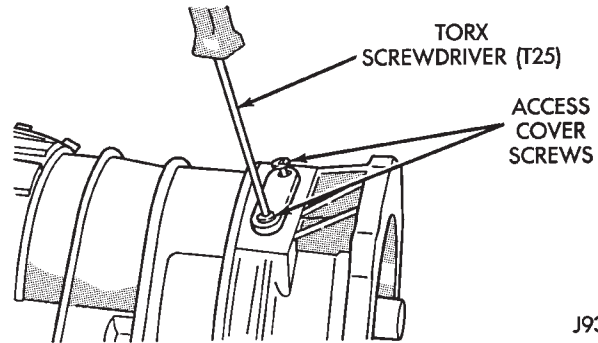


Fig. 203 Access Cover Screw Removal/Installation

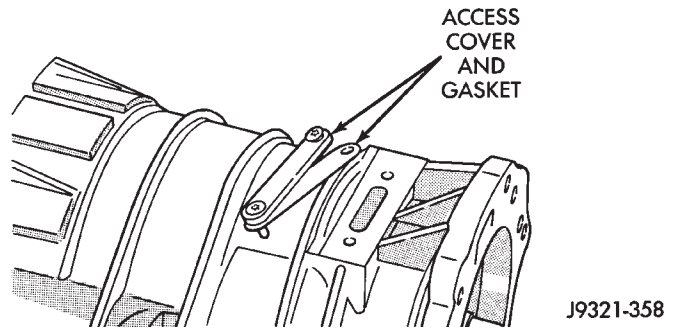


Fig. 204 Access Cover And Gasket Removal/Installation

OVERDRIVE GEARTRAIN

- (1) Remove overdrive clutch wave spring (Fig. 201).
- (2) Remove overdrive clutch reaction snap ring (Fig. 202). Note that snap ring is located in same groove as wave spring.
- (3) Remove Torx head screws that attach access cover and gasket to overdrive case (Fig. 203).
- (4) Remove access cover and gasket (Fig. 204).

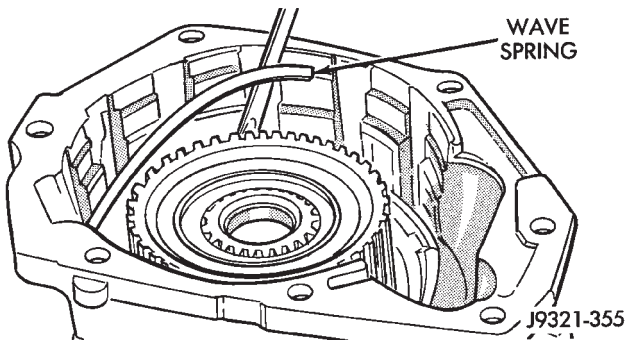


Fig. 201 Overdrive Clutch Wave Spring Removal/Installation

DISASSEMBLY AND ASSEMBLY (Continued)

(5) Expand output shaft bearing snap ring with expanding-type snap ring pliers. Then push output shaft forward to release shaft bearing from locating ring (Fig. 205).

(6) Lift gear case up and off geartrain assembly (Fig. 206).

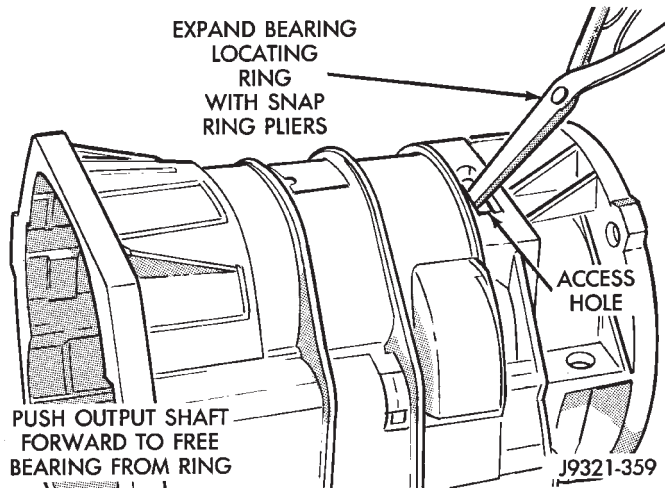


Fig. 205 Releasing Bearing From Locating Ring

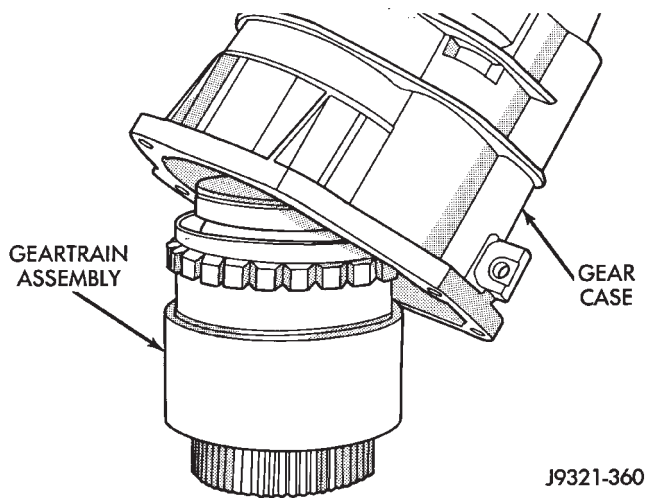


Fig. 206 Removing Gear Case From Geartrain Assembly

(7) Remove snap ring that retains rear bearing on output shaft.

(8) Remove rear bearing from output shaft (Fig. 207).

DIRECT CLUTCH, HUB AND SPRING

WARNING: THE NEXT STEP IN DISASSEMBLY INVOLVES COMPRESSING THE DIRECT CLUTCH SPRING. IT IS EXTREMELY IMPORTANT THAT PROPER EQUIPMENT BE USED TO COMPRESS THE SPRING AS SPRING FORCE IS APPROXIMATELY 830 POUNDS. USE SPRING COMPRESSOR TOOL 6227-1 AND A HYDRAULIC SHOP PRESS WITH A MINIMUM RAM TRAVEL OF 5-6 INCHES. THE PRESS MUST ALSO HAVE A BED THAT CAN BE ADJUSTED UP OR DOWN AS REQUIRED.

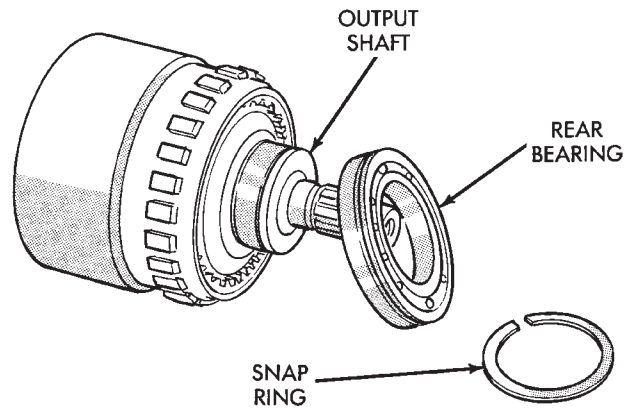


Fig. 207 Rear Bearing Removal

RELEASE CLUTCH SPRING TENSION SLOWLY AND COMPLETELY TO AVOID PERSONAL INJURY.

(1) Mount geartrain assembly in shop press (Fig. 208).

(2) Position Compressor Tool 6227-1 on clutch hub (Fig. 208). Support output shaft flange with steel press plates as shown and center assembly under press ram.

(3) Apply press pressure slowly. Compress hub and spring far enough to expose clutch hub retaining ring and relieve spring pressure on clutch pack snap ring (Fig. 208).

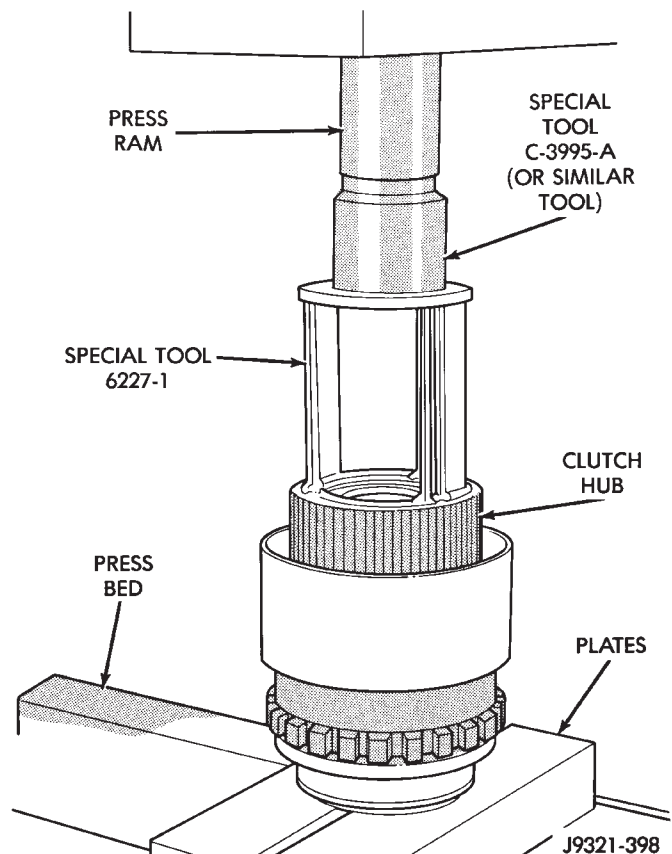


Fig. 208 Geartrain Mounted In Shop Press

DISASSEMBLY AND ASSEMBLY (Continued)

- (4) Remove direct clutch pack snap ring (Fig. 209).
- (5) Remove direct clutch hub retaining ring (Fig. 210).
- (6) Release press load slowly and completely (Fig. 211).
- (7) Remove Special Tool 6227-1. Then remove clutch pack from hub (Fig. 211).

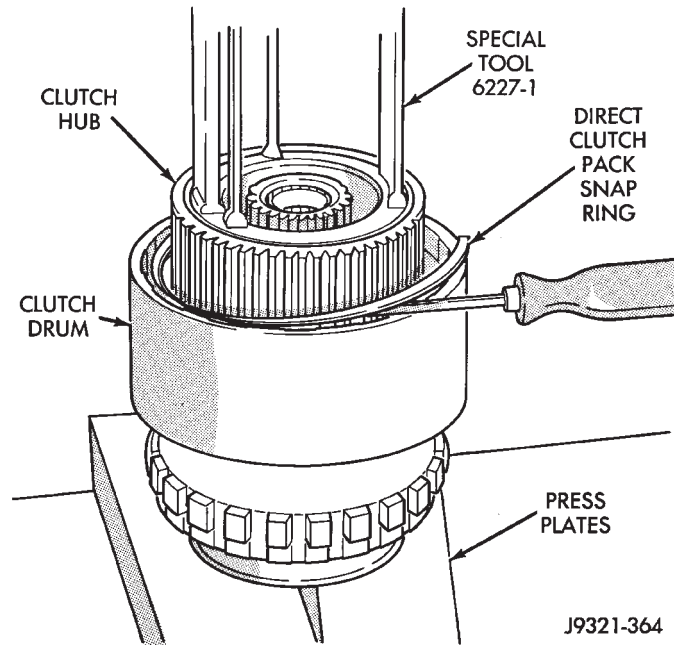


Fig. 209 Direct Clutch Pack Snap Ring Removal

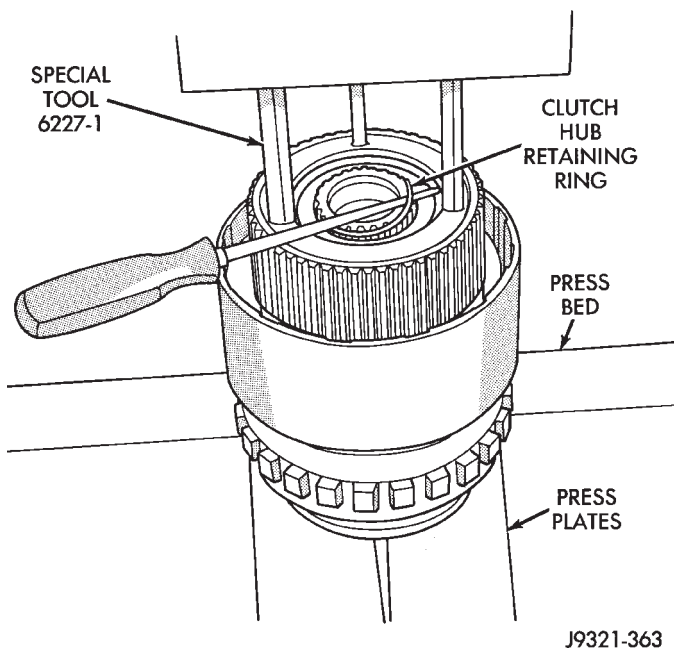


Fig. 210 Direct Clutch Hub Retaining Ring Removal

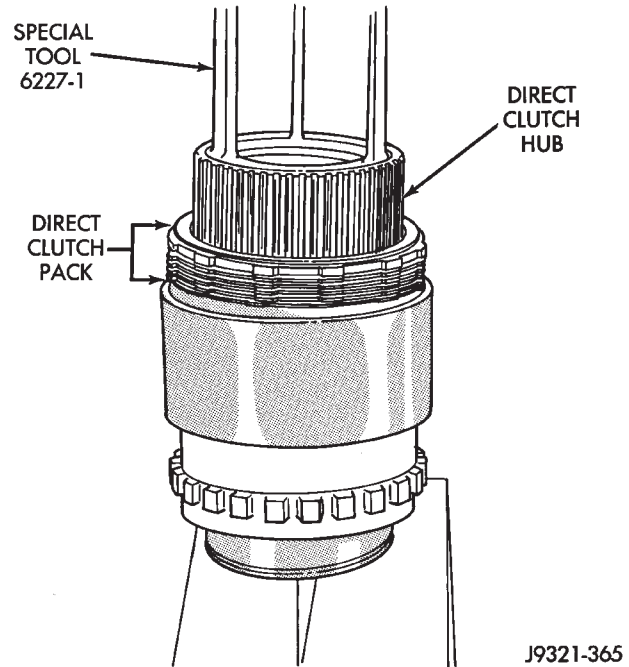


Fig. 211 Direct Clutch Pack Removal

Geartrain

- (1) Remove direct clutch hub and spring (Fig. 212).
- (2) Remove sun gear and spring plate. Then remove planetary thrust bearing and planetary gear (Fig. 213).

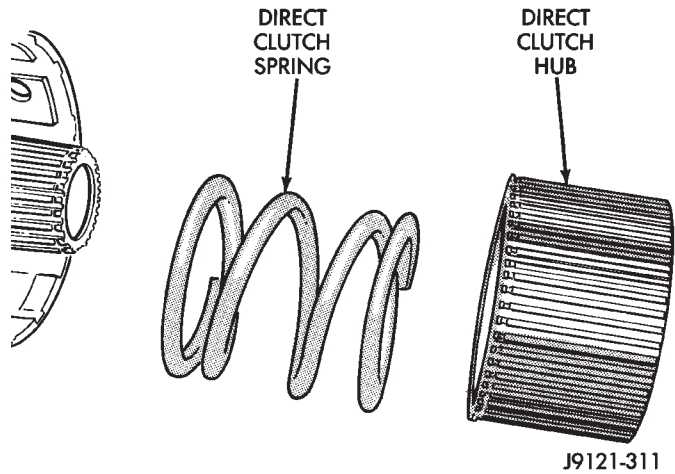


Fig. 212 Direct Clutch Hub And Spring Removal

- (3) Remove overrunning clutch assembly with expanding type snap ring pliers (Fig. 214). Insert pliers into clutch hub. Expand pliers to grip hub splines and remove clutch with counterclockwise, twisting motion.
- (4) Remove thrust bearing from overrunning clutch hub.
- (5) Remove overrunning clutch from hub.
- (6) Mark position of annulus gear and direct clutch drum for assembly alignment reference (Fig. 215). Use small center punch or scriber to make alignment marks.

DISASSEMBLY AND ASSEMBLY (Continued)

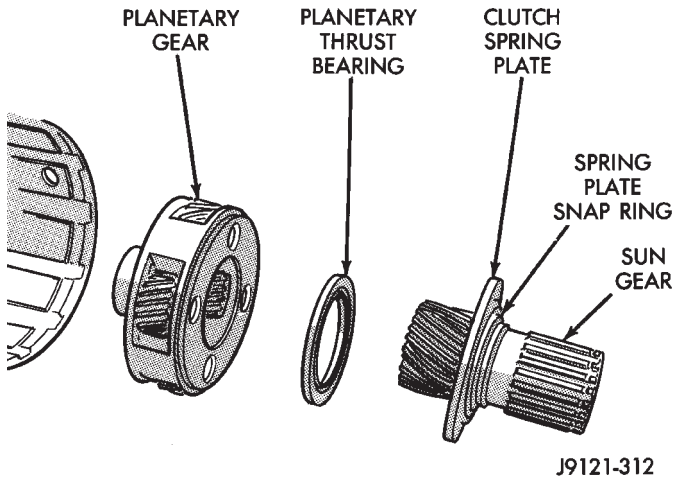


Fig. 213 Removing Sun Gear, Thrust Bearing And Planetary Gear

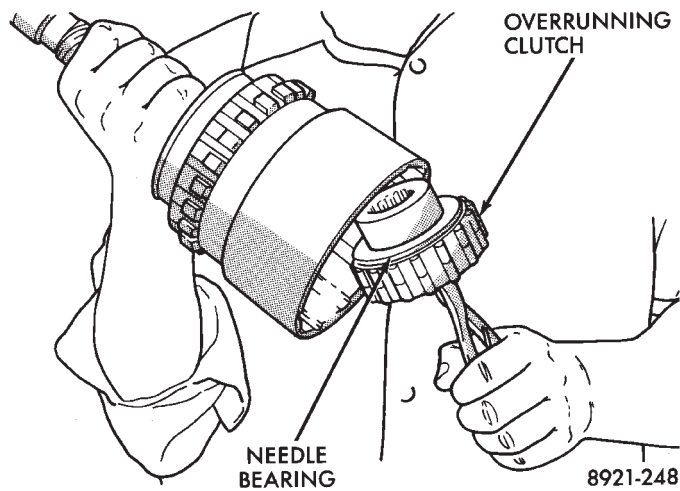


Fig. 214 Overrunning Clutch Assembly Removal/ Installation

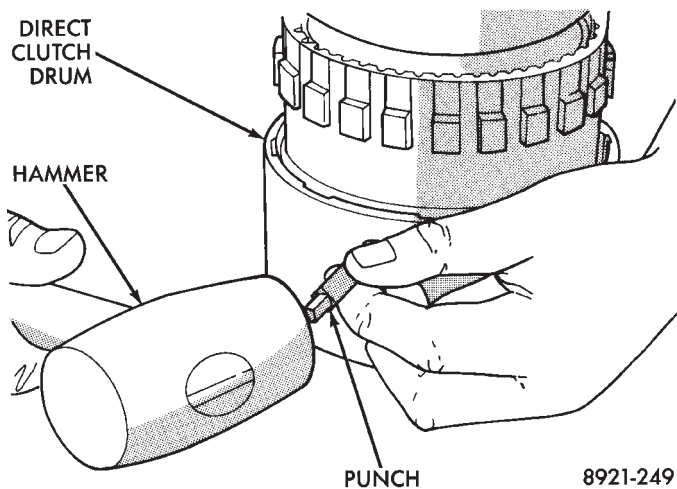


Fig. 215 Marking Direct Clutch Drum And Annulus Gear For Assembly Alignment

- (7) Remove direct clutch drum rear retaining ring (Fig. 216).
- (8) Remove direct clutch drum outer retaining ring (Fig. 217).
- (9) Mark annulus gear and output shaft for assembly alignment reference (Fig. 218). Use punch or scriber to mark gear and shaft.

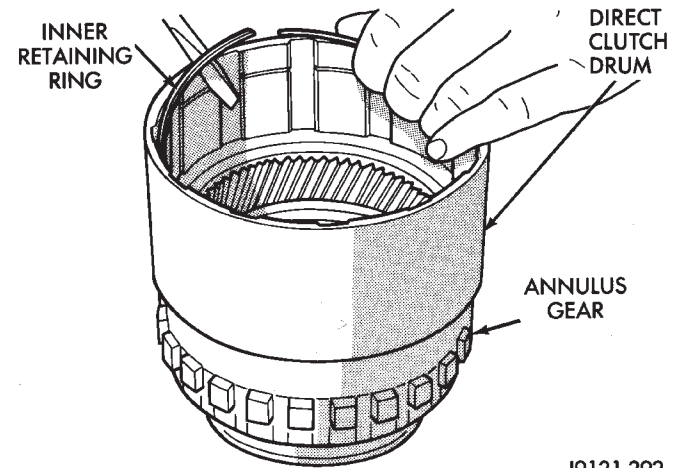


Fig. 216 Clutch Drum Inner Retaining Ring Removal

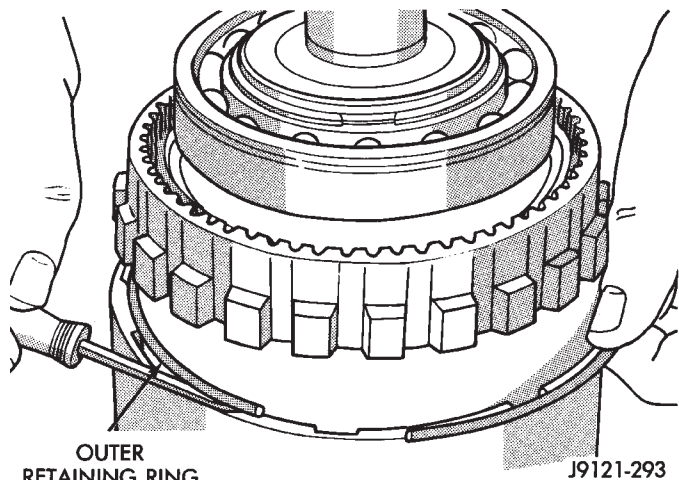


Fig. 217 Clutch Drum Outer Retaining Ring Removal

- (10) Remove snap ring that secures annulus gear on output shaft (Fig. 219). Use two screwdrivers to unseat and work snap ring out of groove as shown.
- (11) Remove annulus gear from output shaft (Fig. 220). Use rawhide or plastic mallet to tap gear off shaft.

GEAR CASE AND PARK LOCK

- (1) Remove locating ring from gear case.
- (2) Remove park pawl shaft retaining bolt and remove shaft, pawl and spring.
- (3) Remove reaction plug snap ring and remove reaction plug.
- (4) Remove output shaft seal.

DISASSEMBLY AND ASSEMBLY (Continued)

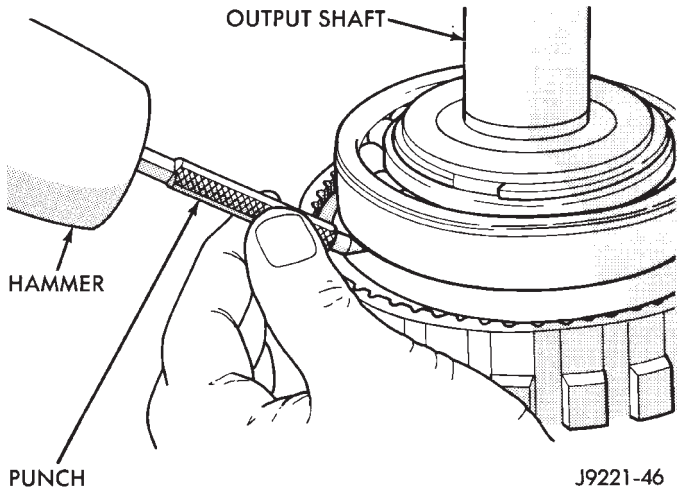


Fig. 218 Marking Annulus Gear And Output Shaft For Assembly Alignment

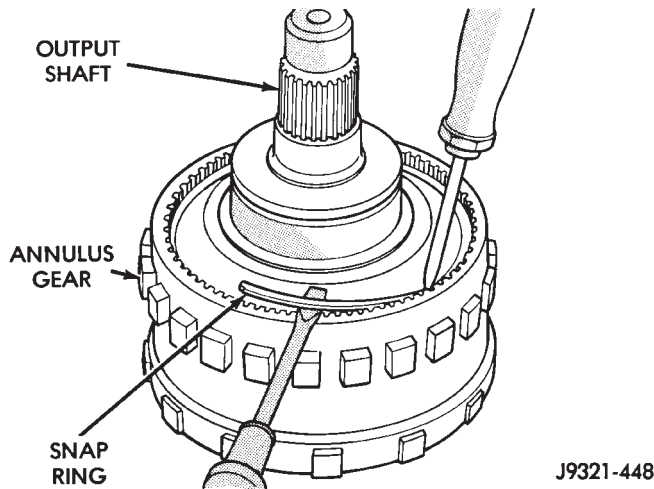


Fig. 219 Annulus Gear Snap Ring Removal

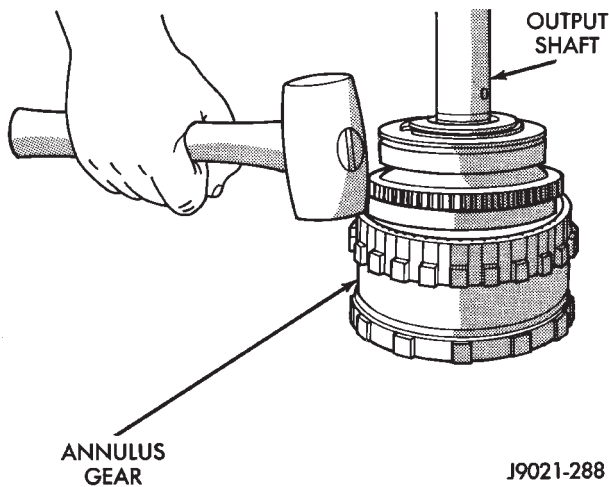


Fig. 220 Annulus Gear Removal

ASSEMBLY

GEARTRAIN AND DIRECT CLUTCH

(1) Soak direct clutch and overdrive clutch discs in Mopar® ATF Plus 3, type 7176, transmission fluid. Allow discs to soak for 10-20 minutes.

(2) Install new pilot bushing and clutch hub bushing in output shaft if necessary (Fig. 221). Lubricate bushings with petroleum jelly, or transmission fluid.

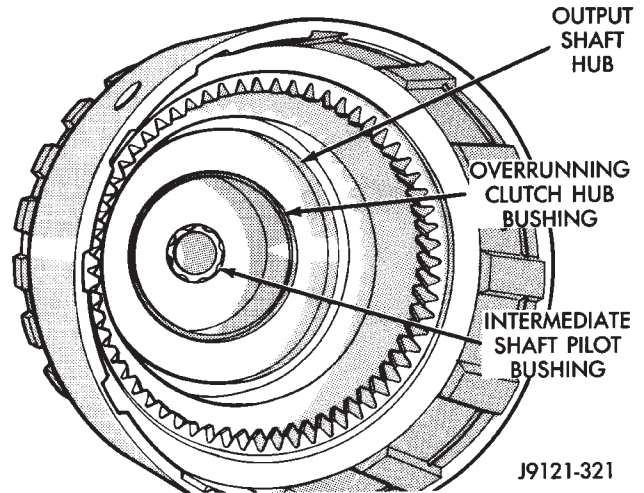


Fig. 221 Output Shaft Pilot Bushing

(3) Install annulus gear on output shaft, if removed. Then install annulus gear retaining snap ring (Fig. 222).

(4) Align and install clutch drum on annulus gear (Fig. 223). Be sure drum is engaged in annulus gear lugs.

(5) Install clutch drum outer retaining ring (Fig. 223).

(6) Slide clutch drum forward and install inner retaining ring (Fig. 224).

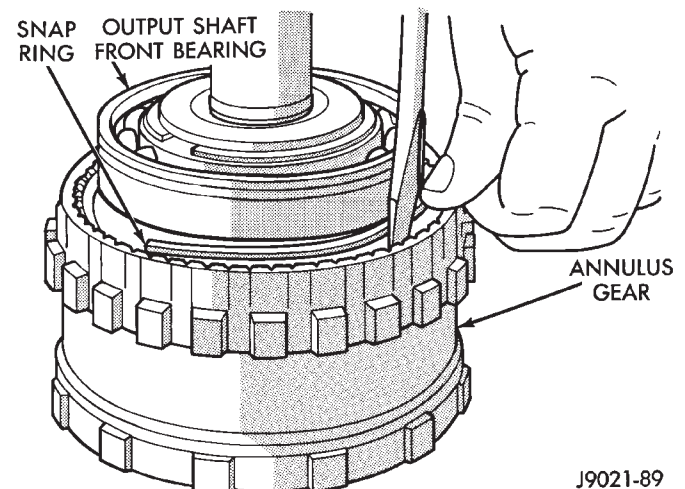


Fig. 222 Annulus Gear Installation

DISASSEMBLY AND ASSEMBLY (Continued)

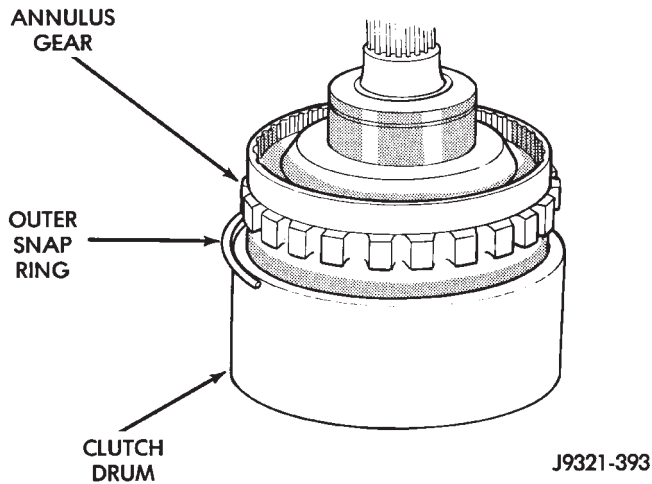


Fig. 223 Clutch Drum And Outer Retaining Ring Installation

(7) Install rear bearing and snap ring on output shaft (Fig. 225). Be sure locating ring groove in bearing is toward rear.

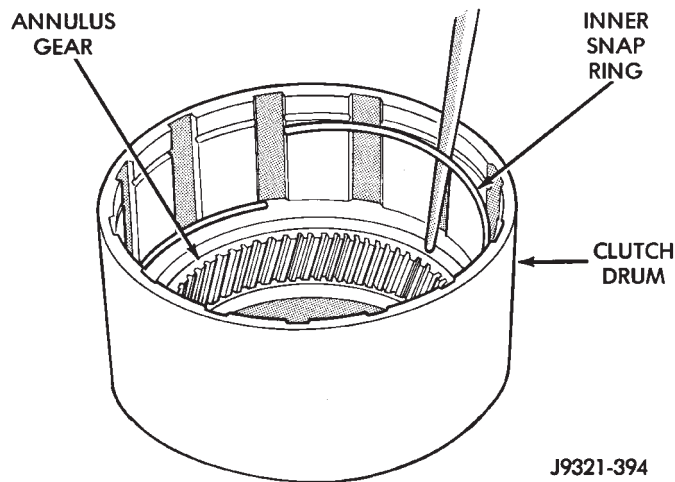


Fig. 224 Clutch Drum Inner Retaining Ring Installation

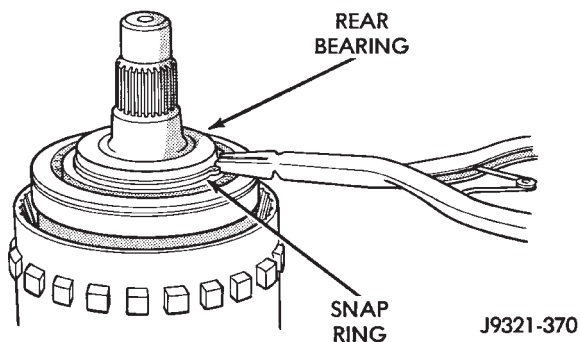


Fig. 225 Rear Bearing And Snap Ring Installation

(8) Install overrunning clutch on hub (Fig. 226). **Note that clutch only fits one way. Shoulder on clutch should seat in small recess at edge of hub.**

(9) Install thrust bearing on overrunning clutch hub. Use generous amount of petroleum jelly to hold bearing in place for installation. **Bearing fits one way only. Be sure bearing is seated squarely against hub. Reinstall bearing if it does not seat squarely.**

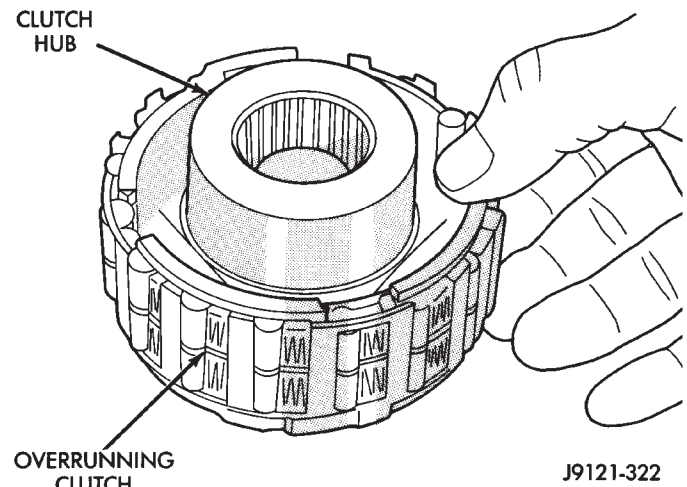


Fig. 226 Assembling Overrunning Clutch And Hub

(10) Install overrunning clutch in output shaft (Fig. 227). Insert snap ring pliers in hub splines. Expand pliers to grip hub. Then install assembly with counterclockwise, twisting motion.

(11) Install planetary gear in annulus gear (Fig. 228). **Be sure planetary pinions are fully seated in annulus gear before proceeding.**

(12) Coat planetary thrust bearing and bearing contact surface of spring plate with generous amount of petroleum jelly. This will help hold bearing in place during installation.

(13) Install planetary thrust bearing on sun gear (Fig. 229). Slide bearing onto gear and seat it against spring plate as shown. **Bearing fits one way only. If it does not seat squarely against spring plate, remove and reposition bearing.**

(14) Install assembled sun gear, spring plate and thrust bearing (Fig. 230). Be sure sun gear and thrust bearing are fully seated before proceeding.

(15) Mount assembled output shaft, annulus gear, and clutch drum in shop press. Direct clutch spring, hub and clutch pack are easier to install with assembly mounted in press.

(16) Align splines in hubs of planetary gear and overrunning clutch with Alignment tool 6227-2 (Fig. 231). Insert tool through sun gear and into splines of both hubs. Be sure alignment tool is fully seated before proceeding.

DISASSEMBLY AND ASSEMBLY (Continued)

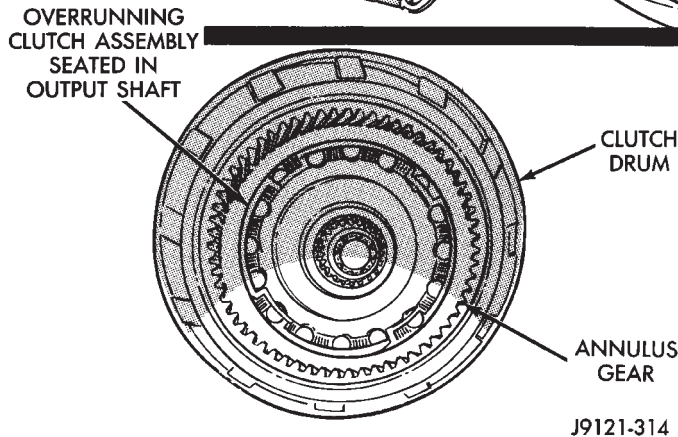
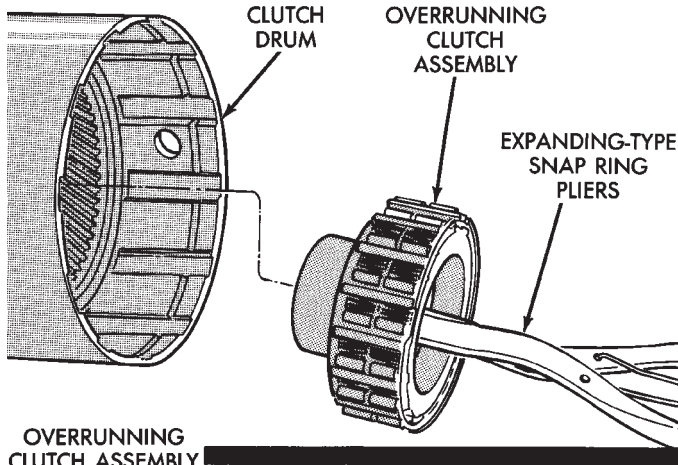


Fig. 227 Overrunning Clutch Installation

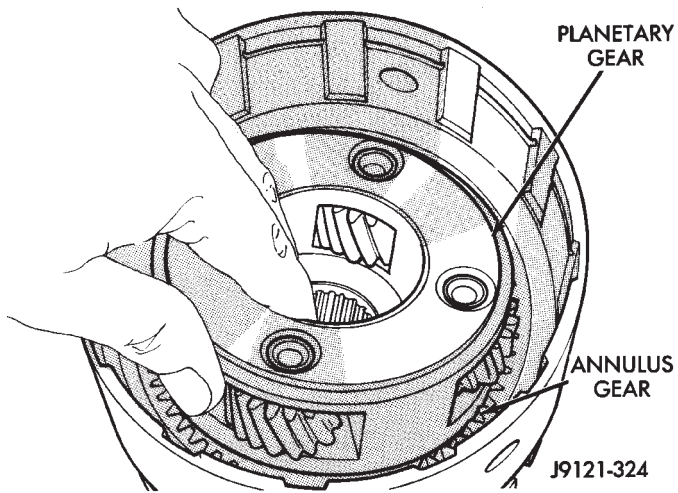


Fig. 228 Planetary Gear Installation

(17) Install direct clutch spring (Fig. 232). Be sure spring is properly seated on spring plate.

(18) Assemble and install direct clutch pack on hub as follows:

(a) Assemble clutch pack components (Fig. 233).

(b) Install direct clutch reaction plate on clutch hub first. **Note that one side of reaction plate is counterbored. Be sure this side faces rearward. Splines at rear of hub are raised**

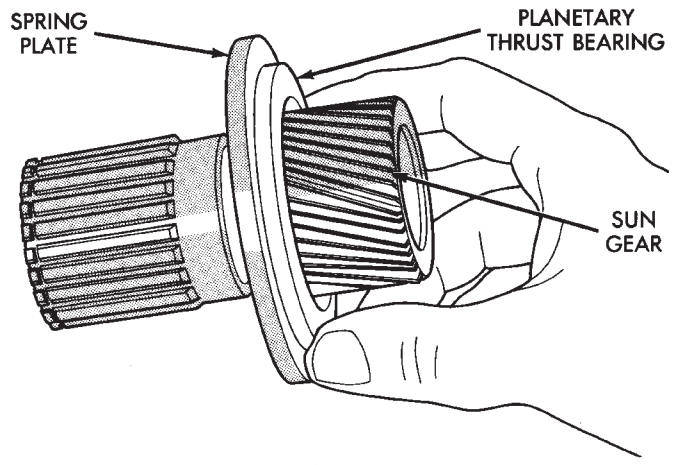


Fig. 229 Planetary Thrust Bearing Installation

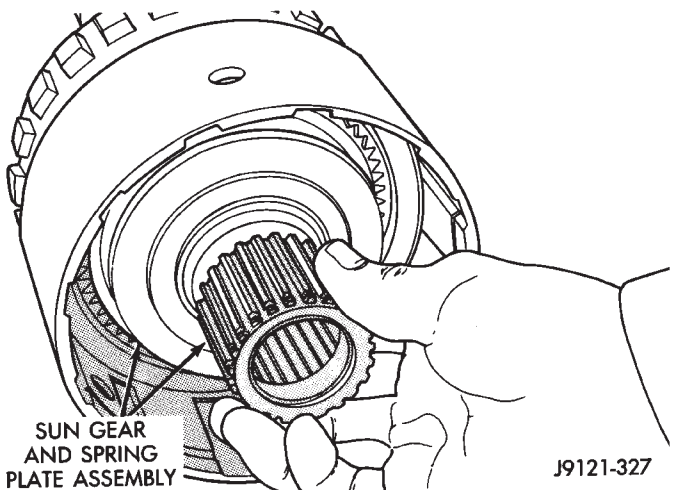


Fig. 230 Sun Gear Installation

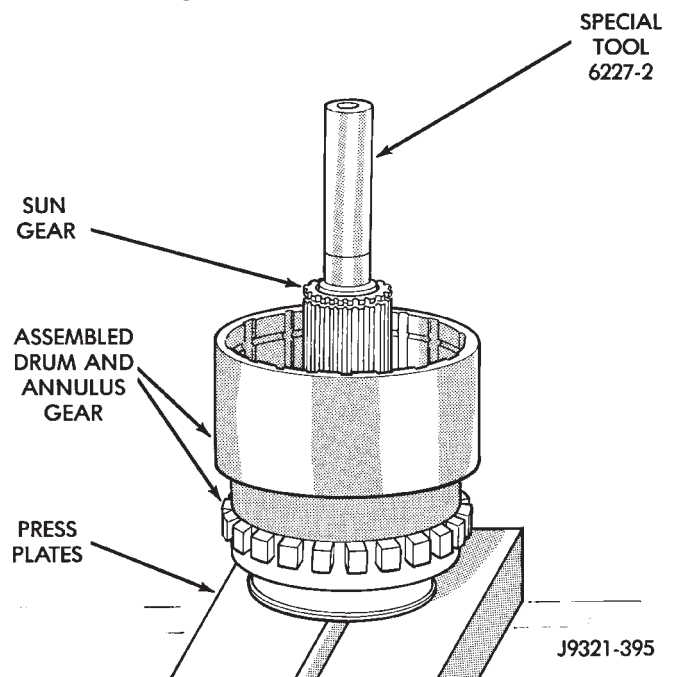


Fig. 231 Alignment Tool Installation

J9321-395

DISASSEMBLY AND ASSEMBLY (Continued)

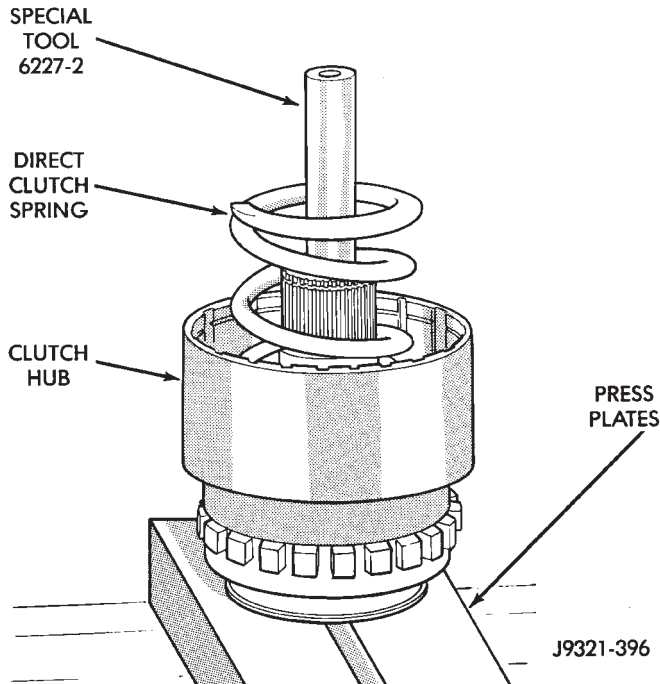


Fig. 232 Direct Clutch Spring Installation

slightly. Counterbore in plate fits over raised splines. Plate should be flush with this end of hub (Fig. 234).

(c) Install first clutch disc followed by a steel plate until all discs and plates have been installed.

(d) Install pressure plate. This is last clutch pack item to be installed. **Be sure plate is installed with shoulder side facing upward (Fig. 235).**

(19) Install clutch hub and clutch pack on direct clutch spring (Fig. 236). **Be sure hub is started on sun gear splines before proceeding.**

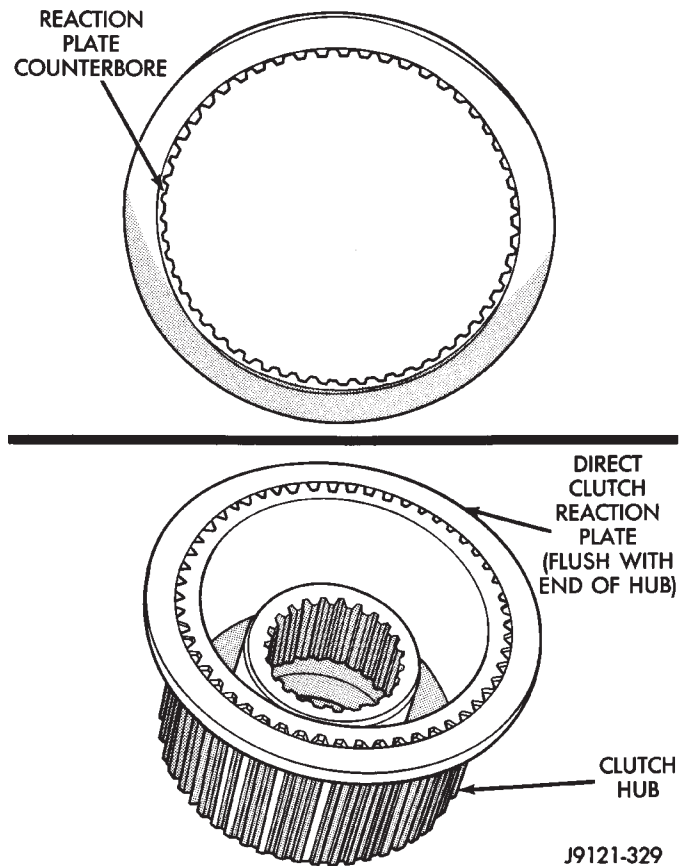


Fig. 234 Correct Position Of Direct Clutch Reaction Plate

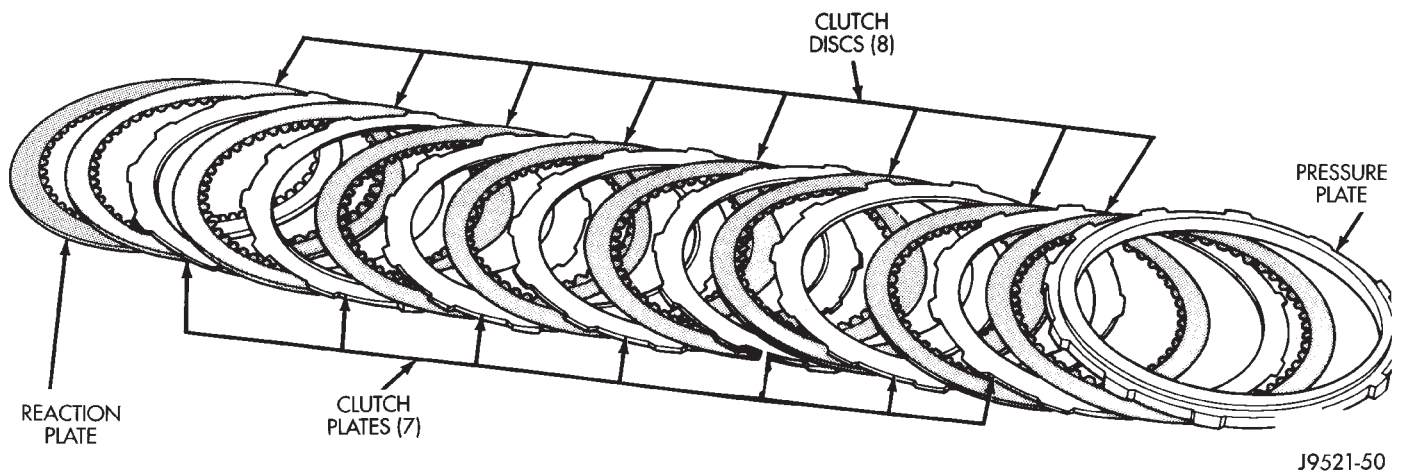


Fig. 233 46RE Direct Clutch Pack Components

DISASSEMBLY AND ASSEMBLY (Continued)

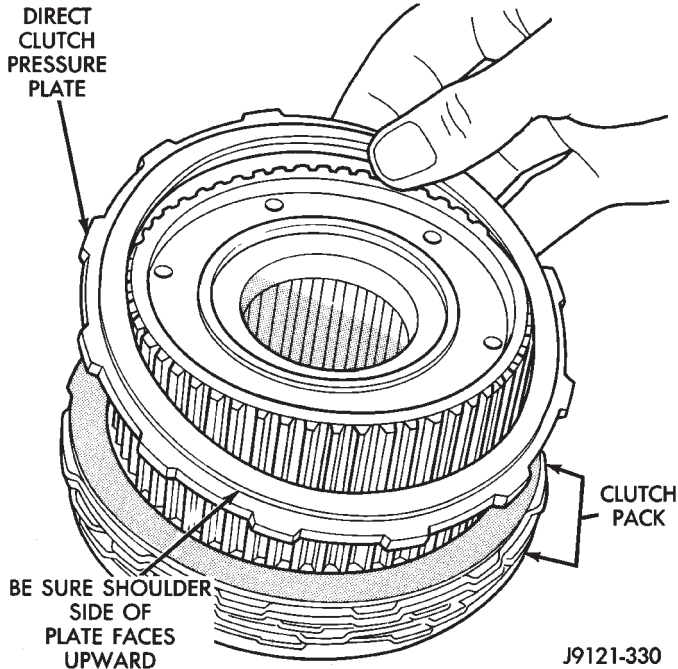


Fig. 235 Correct Position Of Direct Clutch Pressure Plate

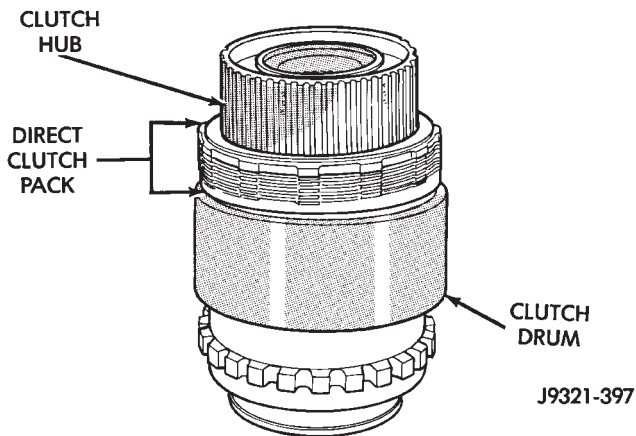


Fig. 236 Direct Clutch Pack And Clutch Hub Installation

WARNING: THE NEXT STEP IN GEARTRAIN ASSEMBLY INVOLVES COMPRESSING THE DIRECT CLUTCH HUB AND SPRING. IT IS EXTREMELY IMPORTANT THAT PROPER EQUIPMENT BE USED TO COMPRESS THE SPRING AS SPRING FORCE IS APPROXIMATELY 830 POUNDS. USE COMPRESSOR TOOL C-6227-1 AND A HYDRAULIC-TYPE SHOP PRESS WITH A MINIMUM RAM TRAVEL OF 6 INCHES. THE PRESS MUST ALSO HAVE A BED THAT CAN BE ADJUSTED UP OR DOWN AS REQUIRED. RELEASE CLUTCH SPRING TENSION SLOWLY AND COMPLETELY TO AVOID PERSONAL INJURY.

(20) Position Compressor Tool 6227-1 on clutch hub.

(21) Compress clutch hub and spring just enough to place tension on hub and hold it in place.

(22) Slowly compress clutch hub and spring. Compress spring and hub only enough to expose ring grooves for clutch pack snap ring and clutch hub retaining ring.

(23) Realign clutch pack on hub and seat clutch discs and plates in clutch drum.

(24) Install direct clutch pack snap ring (Fig. 237). **Be very sure snap ring is fully seated in clutch drum ring groove.**

(25) Install clutch hub retaining ring (Fig. 238). **Be very sure retaining ring is fully seated in sun gear ring groove.**

(26) Slowly release press ram, remove compressor tools and remove geartrain assembly.

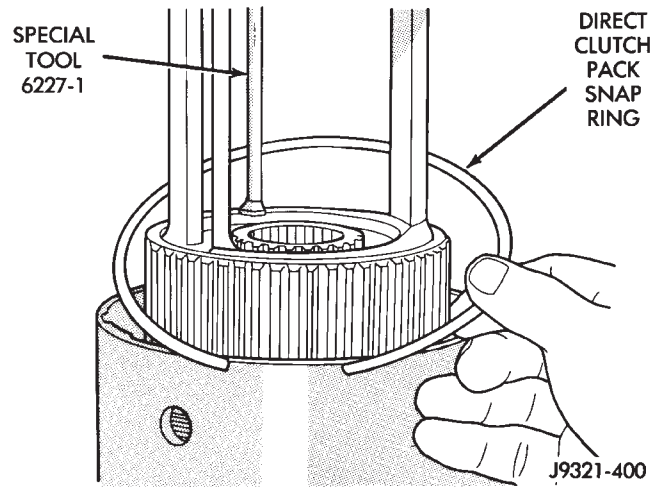


Fig. 237 Direct Clutch Pack Snap Ring Installation

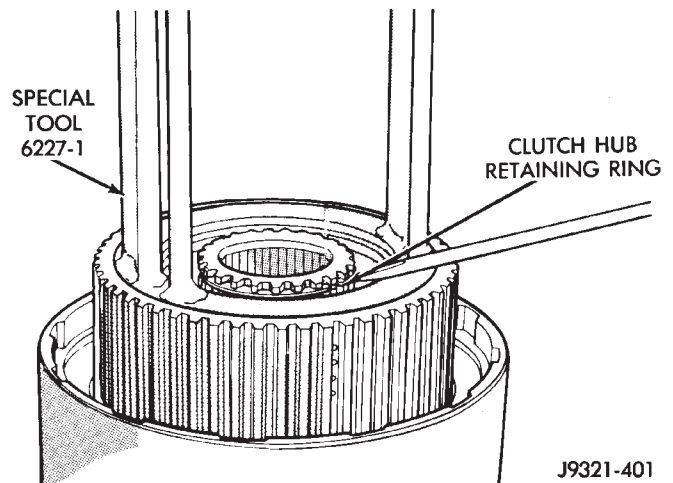


Fig. 238 Clutch Hub Retaining Ring Installation

GEAR CASE

(1) Position park pawl and spring in case and install park pawl shaft. Verify that end of spring

DISASSEMBLY AND ASSEMBLY (Continued)

with 90° bend is hooked to pawl and straight end of spring is seated against case.

(2) Install pawl shaft retaining bolt. Tighten bolt to 27 N-m (20 ft. lbs.) torque.

(3) Install park lock reaction plug. **Note that plug has locating pin at rear (Fig. 239). Be sure pin is seated in hole in case before installing snap ring.**

(4) Install reaction plug snap-ring (Fig. 240). **Compress snap ring only enough for installation; do not distort it.**

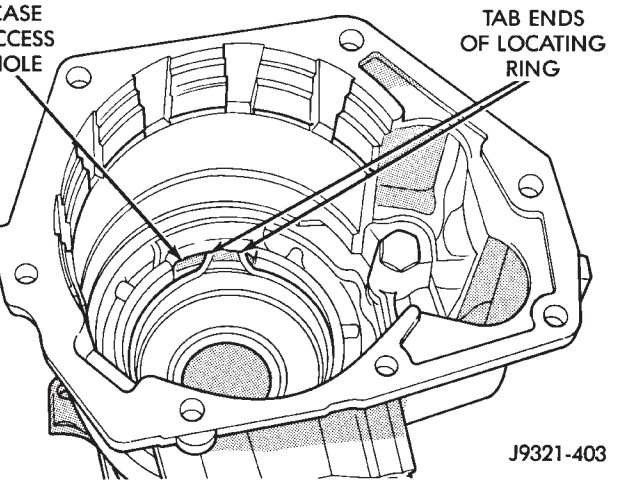
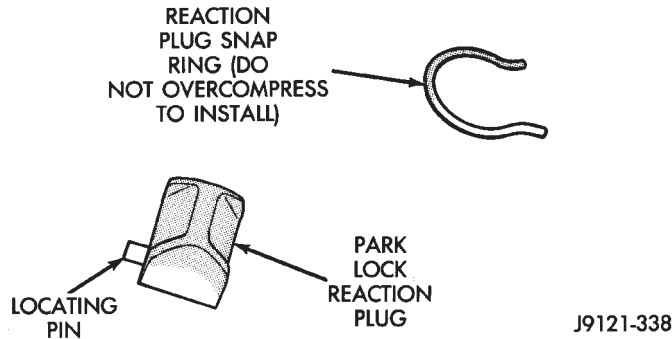


Fig. 241 Correct Rear Bearing Locating Ring Position

Fig. 239 Reaction Plug Locating Pin And Snap-Ring

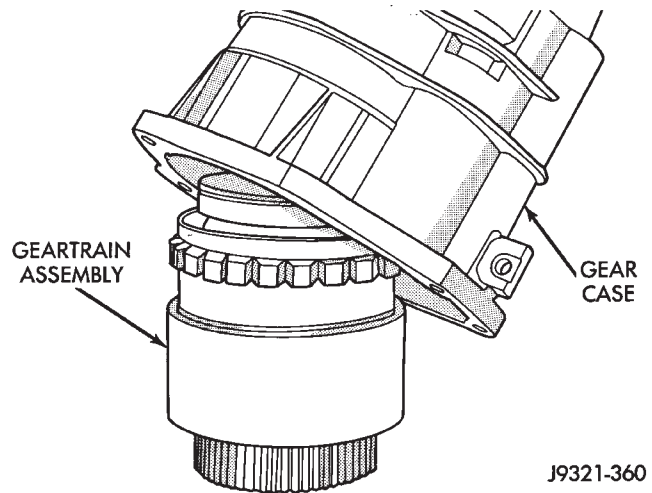
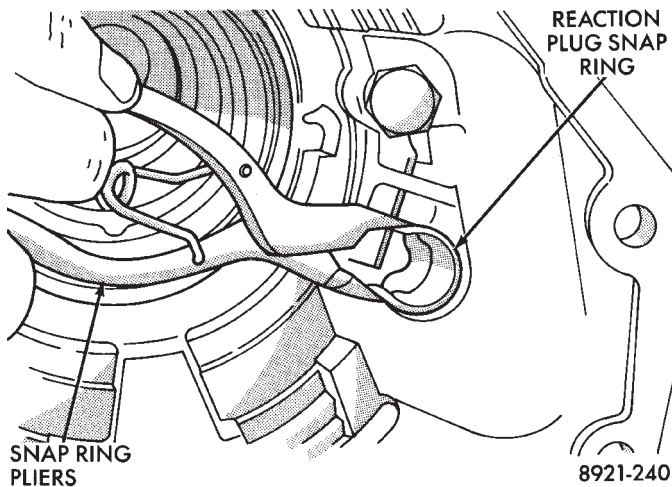


Fig. 242 Overdrive Gear Case Installation

Fig. 240 Reaction Plug And Snap-Ring Installation

(5) Install new seal in gear case. Use Handle C-4171 and Installer C-3995-A to seat seal in case.

(6) Verify that tab ends of rear bearing locating ring extend into access hole in gear case (Fig. 241).

(7) Support geartrain on Tool 6227-1 (Fig. 242). Be sure tool is securely seated in clutch hub.

(8) Install overdrive gear case on geartrain (Fig. 242).

(9) Expand front bearing locating ring with snap ring pliers (Fig. 243). Then slide case downward until locating ring locks in bearing groove and release snap ring.

(10) Install locating ring access cover and gasket in overdrive unit case (Fig. 244).

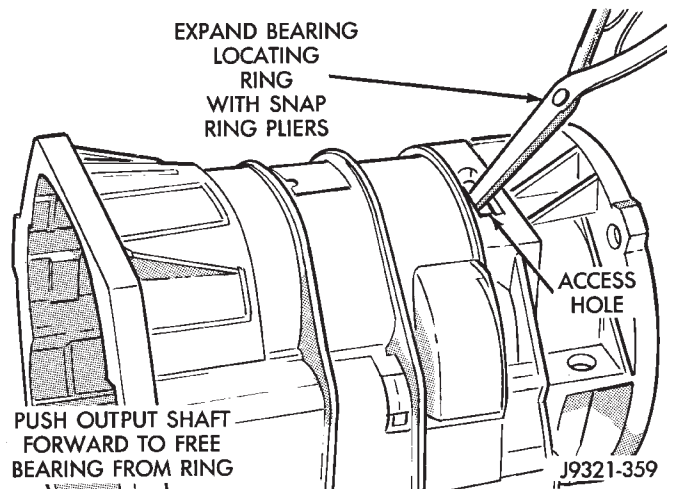


Fig. 243 Seating Locating Ring In Rear Bearing

DISASSEMBLY AND ASSEMBLY (Continued)

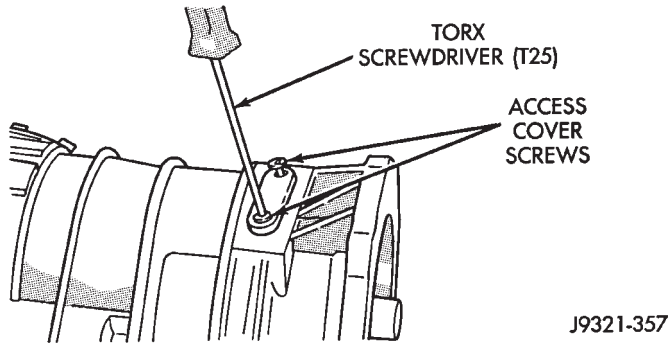


Fig. 244 Locating Ring Access Cover And Gasket Installation

OVERDRIVE CLUTCH

(1) Install overdrive clutch reaction ring first. Reaction ring is flat with notched ends (Fig. 245).

(2) Install wave spring on top of reaction ring (Fig. 246). **Reaction ring and wave ring both fit in same ring groove.** Use screwdriver to seat each ring securely in groove. Also ensure that the ends of the two rings are offset from each other.

(3) Assemble overdrive clutch pack (Fig. 247).

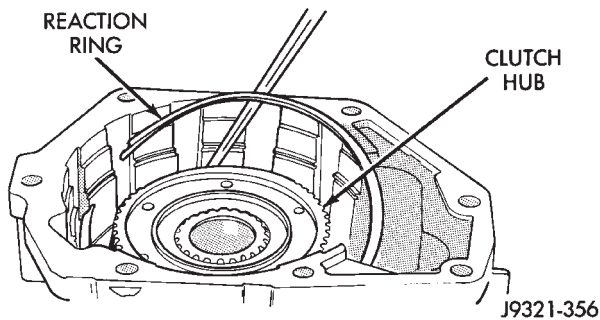


Fig. 245 Overdrive Clutch Reaction Ring Installation

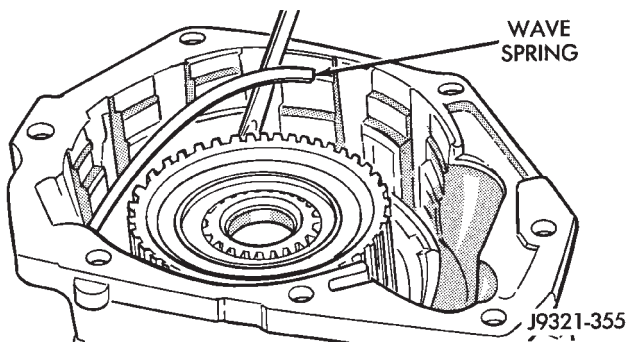


Fig. 246 Overdrive Clutch Wave Spring Installation

- (4) Install overdrive clutch reaction plate first.
- (5) Install first clutch disc followed by first clutch plate. Then install remaining clutch discs and plates in same order.
- (6) Install clutch pack pressure plate.
- (7) Install clutch pack wire-type retaining ring (Fig. 248).

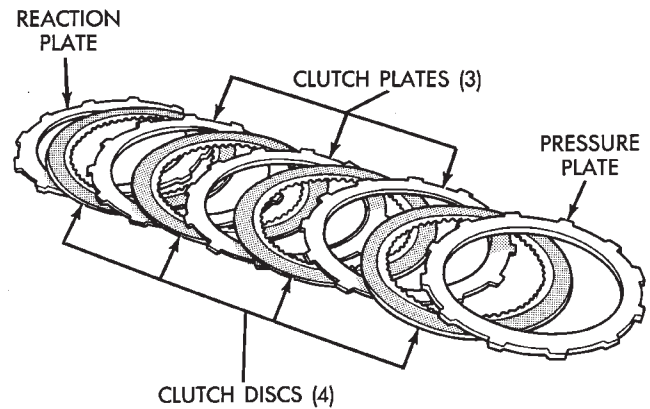


Fig. 247 46RE Overdrive Clutch Components

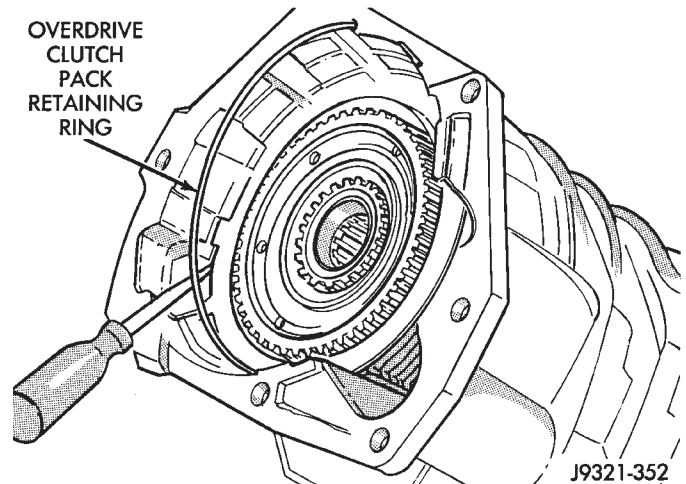


Fig. 248 Overdrive Clutch Pack Retaining Ring Installation

INTERMEDIATE SHAFT SPACER SELECTION

(1) Place overdrive unit in vertical position. Mount it on blocks, or in workbench with appropriate size mounting hole cut into it. Be sure unit is facing upward for access to direct clutch hub. Also be sure output shaft is not loaded and internal components are moved rearward for accurate measurement.

(2) Determine correct thickness intermediate shaft spacer as follows:

(a) Insert Special Tool 6312 through sun gear, planetary gear and into pilot bushing in output shaft. Be sure tool bottoms against planetary shoulder.

(b) Position Gauge Tool 6311 across face of overdrive case (Fig. 249). Then position Dial Caliper C-4962 over gauge tool.

(c) Extend sliding scale of dial caliper downward through gauge tool slot until scale contacts end of Gauge Alignment Tool 6312. Lock scale in place. Remove dial caliper tool and note distance measured (Fig. 249).

DISASSEMBLY AND ASSEMBLY (Continued)

- (d) Select proper thickness end play spacer from spacer chart based on distance measured (Fig. 250).
- (e) Remove Gauge Alignment Tool 6312.

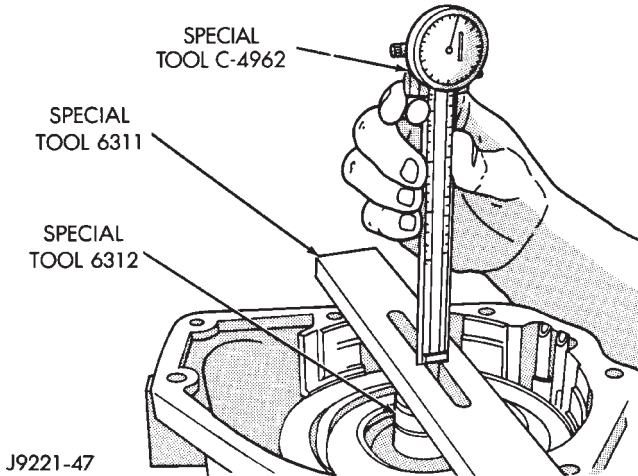


Fig. 249 Shaft End Play Measurement

End Play Measurement (Inches)	Spacer Thickness (Inches)
.7336 - .7505	.158 - .159
.7506 - .7675	.175 - .176
.7676 - .7855	.193 - .194
.7856 - .8011	.211 - .212

J9121-341

Fig. 250 Intermediate Shaft End Play Spacer Selection

OD THRUST PLATE SELECTION

- (1) Place overdrive unit in vertical position. Mount it on blocks, or in workbench with appropriate size mounting hole cut into it. Be sure unit is facing upward for access to direct clutch hub. Also be sure output shaft is not loaded and internal components are moved rearward for accurate measurement.
- (2) Determine correct thickness overdrive piston thrust plate as follows:
 - (a) Position Gauge Tool 6311 across face of overdrive case. Then position Dial Caliper C-4962 over gauge tool (Fig. 251).
 - (b) Measure distance to clutch hub thrust bearing seat at four points 90° apart. Then average measurements by adding them and dividing by 4.
 - (c) Select and install required thrust plate from information in thrust plate chart (Fig. 252).
- (3) Leave Alignment Tool 6227-2 in place. Tool will keep planetary and clutch hub splines in alignment until overdrive unit is ready for installation on transmission.
- (4) Transmission speed sensor can be installed at this time if desired. However, it is recommended that

sensor not be installed until after overdrive unit is secured to transmission.

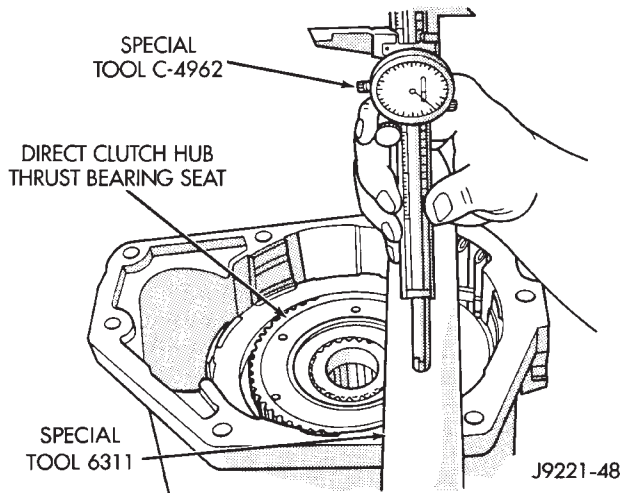


Fig. 251 Overdrive Piston Thrust Plate Measurement

End Play Measurement (Inches)	Spacer Thickness (Inches)
1.7500 - 1.7649	.108 - .110
1.7650 - 1.7799	.123 - .125
1.7800 - 1.7949	.138 - .140
1.7950 - 1.8099	.153 - .155
1.8100 - 1.8249	.168 - .170
1.8250 - 1.8399	.183 - .185
1.8400 - 1.8549	.198 - .200
1.8550 - 1.8699	.213 - .215
1.8700 - 1.8849	.228 - .230
1.8850 - 1.8999	.243 - .245

J9121-342

Fig. 252 Overdrive Piston Thrust Plate Selection

OVERDRIVE PISTON

- (1) Install new seals on overdrive piston.
- (2) Stand transmission case upright on bellhousing.
- (3) Position Guide Ring 8114-1 on outer edge of overdrive piston retainer.
- (4) Position Seal Guide 8114-3 on inner edge of overdrive piston retainer.
- (5) Install overdrive piston in overdrive piston retainer by:
 - (a) Aligning locating lugs on overdrive piston to the two mating holes in retainer.
 - (b) Lubricate overdrive piston seals with Mopar® Door Ease, or equivalent.
 - (c) Install piston over Seal Guide 8114-3 and inside Guide Ring 8114-1.
 - (d) Push overdrive piston into position in retainer.
 - (e) Verify that the locating lugs entered the lug bores in the retainer.
 - (6) Install intermediate shaft spacer on intermediate shaft.

DISASSEMBLY AND ASSEMBLY (Continued)

(7) Install overdrive piston thrust plate on overdrive piston.

(8) Install overdrive piston thrust bearing on overdrive piston.

(9) Install transmission speed sensor and O-ring seal in overdrive case (Fig. 193).

CLEANING AND INSPECTION**VALVE BODY**

Clean the valve housings, valves, plugs, springs, and separator plates with a standard parts cleaning solution only. Do not use gasoline, kerosene, or any type of caustic solution.

Do not immerse any of the electrical components in cleaning solution. Clean the governor solenoid and sensor and the dual solenoid and harness assembly by wiping them off with dry shop towels only.

Dry all except the electrical parts with compressed air. Make sure all passages are clean and free from obstructions. **Do not use rags or shop towels to dry or wipe off valve body components. Lint from these materials can stick to valve body parts, interfere with valve operation, and clog filters and fluid passages.**

Wipe the governor pressure sensor and solenoid valve with dry, lint free shop towels only. The O-rings on the sensor and solenoid valve are the only serviceable components. Be sure the vent ports in the solenoid valve are open and not blocked by dirt or debris. Replace the valve and/or sensor only when DRB scan tool diagnosis indicates this is necessary. Or, if either part has sustained physical damage (dented, deformed, broken, etc.).

CAUTION: Do not turn the small screw at the end of the solenoid valve for any reason. Turning the screw in either direction will ruin solenoid calibration and result in solenoid failure. In addition, the filter on the solenoid valve is NOT serviceable. Do not try to remove the filter as this will damage the valve housing.

Inspect the throttle and manual valve levers and shafts (Fig. 253). Do not attempt to straighten a bent shaft or correct a loose lever. Replace these components if worn, bent, loose or damaged in any way.

Inspect all of the valve body mating surfaces for scratches, nicks, burrs, or distortion. Use a straightedge to check surface flatness. Minor scratches may be removed with crocus cloth using only very light pressure.

Minor distortion of a valve body mating surface may be corrected by smoothing the surface with a sheet of crocus cloth. Position the crocus cloth on a surface plate, sheet of plate glass or equally flat surface. If distortion is severe or any surfaces are heavily scored, the valve body will have to be replaced.

CAUTION: Many of the valves and plugs, such as the throttle valve, shuttle valve plug, 1-2 shift valve and 1-2 governor plug, are made of coated aluminum. Aluminum components are identified by the dark color of the special coating applied to the surface (or by testing with a magnet). Do not sand aluminum valves or plugs under any circumstances. This practice could damage the special coating causing the valves/plugs to stick and bind.

Inspect the valves and plugs for scratches, burrs, nicks, or scores. Minor surface scratches on steel valves and plugs can be removed with crocus cloth but **do not round off the edges of the valve or plug lands.** Maintaining sharpness of these edges is vitally important. The edges prevent foreign matter from lodging between the valves and plugs and the bore.

Inspect all the valve and plug bores in the valve body. Use a penlight to view the bore interiors. Replace the valve body if any bores are distorted or scored. Inspect all of the valve body springs. The springs must be free of distortion, warpage or broken coils.

Check the two separator plates for distortion or damage of any kind. Inspect the upper housing, lower housing, 3-4 accumulator housing, and transfer plate carefully. Be sure all fluid passages are clean and clear. Check condition of the upper housing and transfer plate check balls as well. The check balls and ball seats must not be worn or damaged.

Trial fit each valve and plug in its bore to check freedom of operation. When clean and dry, the valves and plugs should drop freely into the bores.

Valve body bores do not change dimensionally with use. If the valve body functioned correctly when new, it will continue to operate properly after cleaning and inspection. It should not be necessary to replace a valve body assembly unless it is damaged in handling.

The only serviceable valve body components are listed below. The remaining valve body components are serviced only as part of a complete valve body assembly. Serviceable parts are:

- dual solenoid and harness assembly
- solenoid gasket
- solenoid case connector O-rings and shoulder bolt
- switch valve and spring
- pressure adjusting screw and bracket assembly
- throttle lever
- manual lever and shaft seal
- throttle lever shaft seal, washer, and E-clip
- fluid filter and screws
- detent ball and spring
- valve body screws
- governor pressure solenoid
- governor pressure sensor and retaining clip
- park lock rod and E-clip

CLEANING AND INSPECTION (Continued)

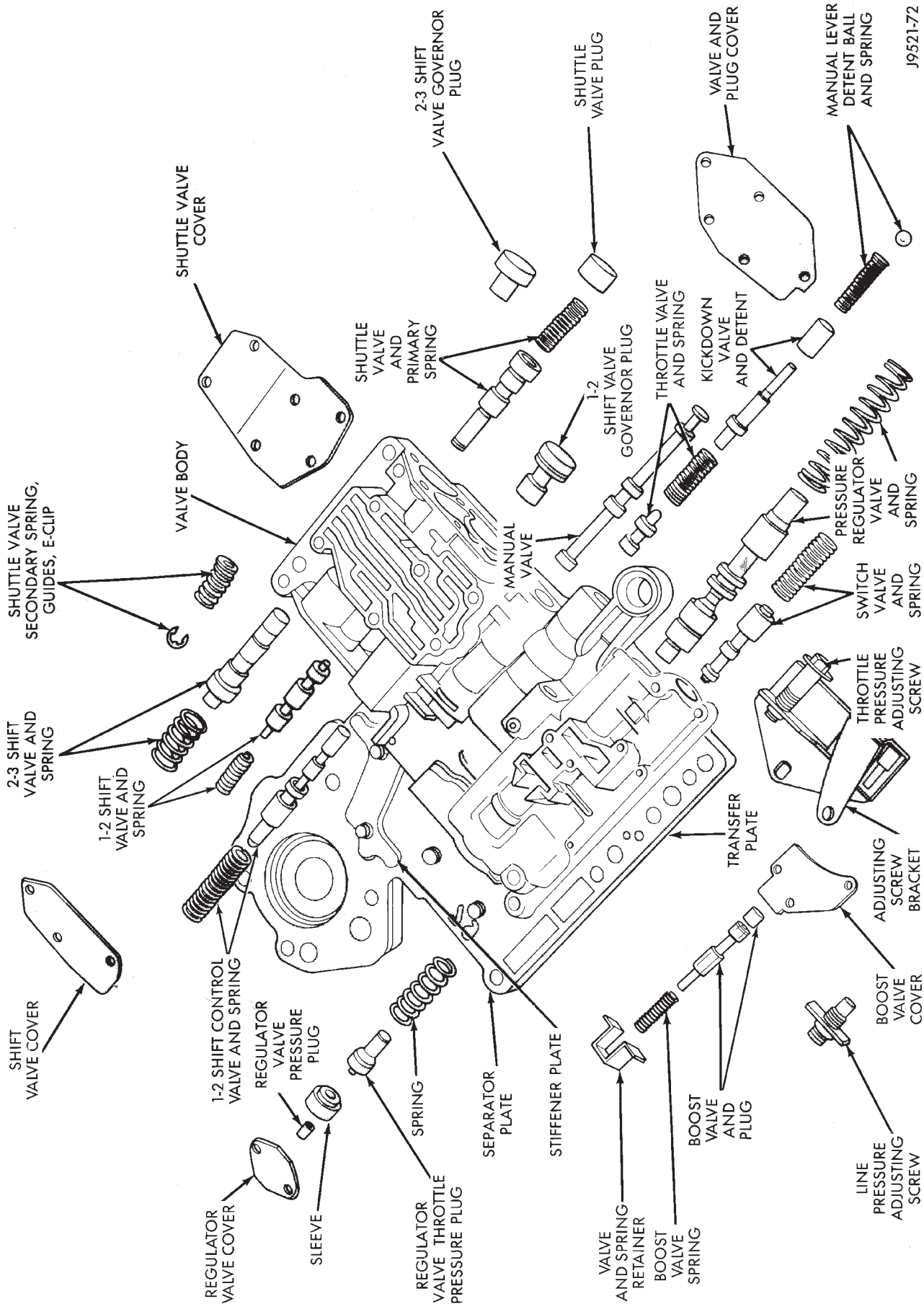


Fig. 253 Upper Housing Valves, Plug, Springs And Brackets

CLEANING AND INSPECTION (Continued)**TRANSMISSION****GENERAL INFORMATION**

Inspect the transmission bushings during overhaul. Bushing condition is important as worn, scored bushings contribute to low pressures, clutch slip and accelerated wear of other components. However, do not replace bushings as a matter of course. Replace bushings only when they are actually worn, or scored.

Use recommended tools to replace bushings. The tools are sized and designed to remove, install, and seat bushings correctly. The bushing replacement tools are included in Bushing Tool Set C-3887-B.

Pre-sized service bushings are available for replacement purposes. Only the sun gear bushings are not serviced. Low cost of the sun gear assembly makes it easier to simply replace the gear and bushings as an assembly.

Heli-Coil inserts can be used to repair damaged, stripped or worn threads in aluminum parts. These inserts are available from most automotive parts suppliers. Stainless steel inserts are recommended.

The use of crocus cloth is permissible where necessary, providing it is used carefully. When used on shafts, or valves, use extreme care to avoid rounding off sharp edges. Sharp edges are vital as they prevent foreign matter from getting between the valve and valve bore.

Do not reuse oil seals, gaskets, seal rings, or O-rings during overhaul. Replace these parts as a matter of course. Also do not reuse snap rings or E-clips that are bent or distorted. Replace these parts as well.

Lubricate transmission parts with Mopar® ATF Plus, Type 7176, transmission fluid during overhaul and assembly. Use petroleum jelly, Mopar® Door Ease, or Ru-Glyde to prelubricate seals, O-rings, and thrust washers. Petroleum jelly can also be used to hold parts in place during reassembly.

TRANSMISSION CASE CLEANING AND INSPECTION

Clean the case in a solvent tank. Flush the case bores and fluid passages thoroughly with solvent. Dry the case and all fluid passages with compressed air. Be sure all solvent is removed from the case and that all fluid passages are clear.

NOTE: Do not use shop towels or rags to dry the case (or any other transmission component) unless they are made from lint-free materials. Lint will stick to case surfaces and transmission components and circulate throughout the transmission after assembly. A sufficient quantity of lint can block fluid passages and interfere with valve body operation.

Inspect the case for cracks, porous spots, worn bores, or damaged threads. Damaged threads can be repaired with Helicoil thread inserts. However, the case will have to be replaced if it exhibits any type of damage or wear.

Lubricate the front band adjusting screw threads with petroleum jelly and thread the screw part-way into the case. Be sure the screw turns freely.

OVERRUNNING CLUTCH/LOW-REVERSE DRUM/OVERDRIVE PISTON RETAINER

Clean the overrunning clutch assembly, clutch cam, low-reverse drum, and overdrive piston retainer in solvent. Dry them with compressed air after cleaning.

Inspect condition of each clutch part after cleaning. Replace the overrunning clutch roller and spring assembly if any rollers or springs are worn or damaged, or if the roller cage is distorted, or damaged. Replace the cam if worn, cracked or damaged.

Replace the low-reverse drum if the clutch race, roller surface or inside diameter is scored, worn or damaged. **Do not remove the clutch race from the low-reverse drum under any circumstances. Replace the drum and race as an assembly if either component is damaged.**

Examine the overdrive piston retainer carefully for wear, cracks, scoring or other damage. Be sure the retainer hub is a snug fit in the case and drum. Replace the retainer if worn or damaged.

ACCUMULATOR

Inspect the accumulator piston and seal rings (Fig. 254). Replace the seal rings if worn or cut. Replace the piston if chipped or cracked.

Check condition of the accumulator inner and outer springs (Fig. 254). Replace the springs if the coils are cracked, distorted or collapsed.

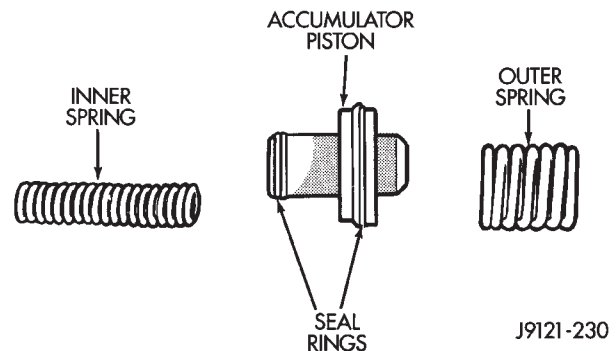


Fig. 254 Accumulator Components

FRONT SERVO

Clean the servo piston components with solvent and dry them with compressed air. Wipe the band clean with lint free shop towels.

CLEANING AND INSPECTION (Continued)

Replace the front band if distorted, lining is burned, flaking off, or worn to the point where the grooves in the lining material are no longer visible.

Inspect the servo components. Replace the springs if collapsed, distorted or broken. Replace the guide, rod and piston if cracked, bent, or worn. Discard the servo snap ring if distorted or warped.

Check the servo piston bore for wear. If the bore is severely scored, or damaged, it will be necessary to replace the case.

Replace any servo component if doubt exists about condition. Do not reuse suspect parts.

REAR SERVO

Remove and discard the servo piston seal ring (Fig. 255). Then clean the servo components with solvent and dry with compressed air. Replace either spring if collapsed, distorted or broken. Replace the plug and piston if cracked, bent, or worn. Discard the servo snap rings and use a new ones at assembly.

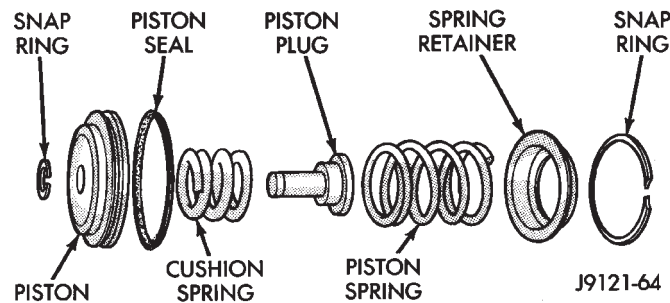


Fig. 255 Rear Servo Components

OIL PUMP AND REACTION SHAFT SUPPORT

Clean pump and support components with solvent and dry them with compressed air.

Check condition of the seal rings and thrust washer on the reaction shaft support. The seal rings do not need to be replaced unless cracked, broken, or severely worn.

Inspect the pump and support components. Replace the pump or support if the seal ring grooves or machined surfaces are worn, scored, pitted, or damaged. Replace the pump gears if pitted, worn chipped, or damaged.

Check the pump vent. The vent must be secure. Replace the pump body if the vent is cracked, broken, or loose.

Inspect the pump bushing. Then check the reaction shaft support bushing. Replace either bushing only if heavily worn, scored or damaged. It is not necessary to replace the bushings unless they are actually damaged.

(1) Install the gears in the pump body and measure pump component clearances as follows:

(a) Clearance between outer gear and reaction shaft housing should be 0.010 to 0.063 mm (0.0004

to 0.0025 in.). Clearance between inner gear and reaction shaft housing should be 0.010 to 0.063 mm (0.0004 to 0.0025 in.). Both clearances can be measured at the same time by:

(I) Installing the pump gears in the pump housing.

(II) Position an appropriate piece of Plastigage™ across both gears.

(III) Align the plastigage to a flat area on the reaction shaft housing.

(IV) Install the reaction shaft to the pump housing.

(V) Separate the reaction shaft housing from the pump housing and measure the Plastigage™ following the instructions supplied with it.

(b) Clearance between inner gear tooth and outer gear should be 0.08 to 0.19 mm (0.0035 to 0.0075 in.). Measure clearance with an appropriate feeler gauge (Fig. 256).

(c) Clearance between outer gear and pump housing should also be 0.010 to 0.19 mm (0.0035 to 0.0075 in.). Measure clearance with an appropriate feeler gauge.

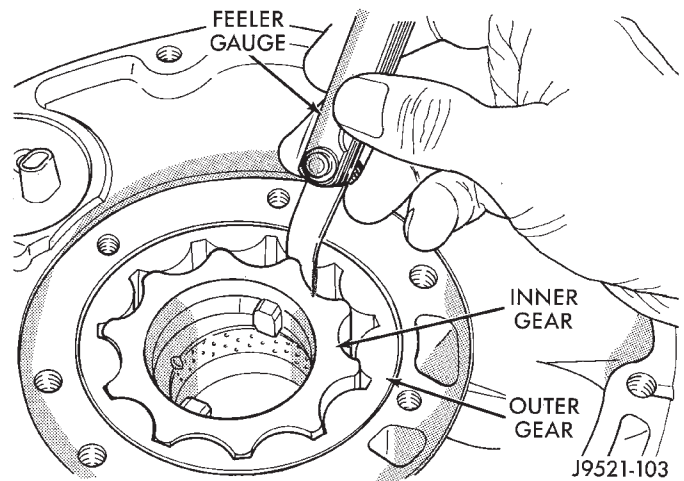


Fig. 256 Checking Pump Gear Tip Clearance

FRONT CLUTCH

Clean and inspect the front clutch components. Replace the clutch discs if warped, worn, scored, burned or charred, the lugs are damaged, or if the facing is flaking off. Replace the steel plates and reaction plate if heavily scored, warped, or broken. Be sure the driving lugs on the discs and plate are also in good condition. The lugs must not be bent, cracked or damaged in any way.

Replace the piston springs and spring retainer if either are distorted, warped or broken.

Check the lug grooves in the clutch piston retainer. The steel plates should slide freely in the slots. Replace the piston retainer if the grooves are worn or damaged. Also check action of the check ball in the

CLEANING AND INSPECTION (Continued)

piston retainer. The ball must move freely and not stick.

Replace the retainer bushing if worn, scored, or there is any doubt about bushing condition.

Inspect the piston and retainer seal surfaces for nicks or scratches. Minor scratches can be removed with crocus cloth. However, replace the piston and/or retainer if the seal surfaces are seriously scored.

Check the clutch piston check ball. The ball should be securely in place. Replace the piston if the ball is missing, or seized in place.

REAR CLUTCH

Clean the clutch components with solvent and dry them with compressed air.

Check condition of the input shaft seal rings. It is not necessary to remove or replace rings unless they are broken, cracked, or no longer securely hooked together.

Inspect the input shaft splines and machined surfaces. Very minor nicks or scratches can be smoothed off with crocus cloth. replace the shaft if the splines are damaged, or any of the machined surfaces are severely scored.

Replace the clutch discs if warped, worn, scored, burned/charred, the lugs are damaged, or if the facing is flaking off.

Replace the steel plates and the pressure plate if heavily scored, warped, or broken. Be sure the driving lugs on the discs and plates are also in good condition. The lugs must not be bent, cracked or damaged in any way.

Replace the piston spring and wave spring if either part is distorted, warped or broken.

Check the lug grooves in the clutch retainer. The steel plates should slide freely in the slots. Replace the retainer if the grooves are worn or damaged. Also check action of the retainer check ball. The ball must move freely and not stick.

Inspect the piston and retainer seal surfaces for nicks or scratches. Minor scratches can be removed with crocus cloth. However, replace the piston and/or retainer if the seal surfaces are seriously damaged.

Check thrust washer condition. Washer thickness should be 1.55 to 1.60 mm (0.061 to 0.063 in.). Replace the washer if worn or damaged.

Check condition of the two seal rings on the input shaft and the single seal ring on the piston retainer hub. Replace the seal rings only if severely worn, cracked, or cannot be hooked together.

PLANETARY GEARTRAIN/OUTPUT SHAFT

Clean the intermediate shaft and planetary components in solvent and dry them with compressed air.

Inspect the planetary gear sets and annulus gears. The planetary pinions, shafts, washers, and retaining

pins are serviceable. However, if a pinion carrier is damaged, the entire planetary gear set must be replaced as an assembly.

Replace the annulus gears if the teeth are chipped, broken, or worn, or the gear is cracked. Replace the planetary thrust plates and the tabbed thrust washers if cracked, scored or worn.

Inspect the machined surfaces of the intermediate shaft. Be sure the oil passages are open and clear. Replace the shaft if scored, pitted, or damaged.

Inspect the sun gear and driving shell. If either component is worn or damaged, remove the sun gear rear retaining ring and separate the sun gear and thrust plate from the driving shell. Then replace the necessary component.

Replace the sun gear as an assembly if the gear teeth are chipped or worn. Also replace the gear as an assembly if the bushings are scored or worn. The sun gear bushings are not serviceable. Replace the thrust plate if worn, or severely scored. Replace the driving shell if distorted, cracked, or damaged in any way.

Replace all snap rings during geartrain assembly. Reusing snap rings is not recommended.

OVERDRIVE UNIT

Clean the geartrain and case components with solvent. Dry all parts except the bearings with compressed air. Allow bearings to air dry.

Do not use shop towels for wiping parts dry unless the towels are made from a lint-free material. A sufficient quantity of lint (from shop towels, cloths, rags, etc.) could plug the transmission filter and fluid passages.

Discard the old case gasket and seals. Do not attempt to salvage these parts. They are not reusable. Replace any of the overdrive unit snap rings if distorted or damaged.

Minor nicks or scratches on components can be smoothed with crocus cloth. However, do not attempt to reduce severe scoring on any components with abrasive materials. Replace severely scored components; do not try to salvage them.

Check condition of the park lock components and the overdrive case.

Replace the case if cracked, scored, or damaged. Replace the park lock pawl, plug, or spring if worn or damaged. Be sure the bullet at the end of the park lock rod is in good condition. Replace the rod if the bullet is worn or the rod itself is bent or distorted. Do not attempt to straighten the rod.

Check the bushings in the overdrive case. Replace the bushings if severely scored or worn. Also replace the case seal if loose, distorted, or damaged.

Examine the overdrive and direct clutch discs and plates. Replace the discs if the facing is worn,

CLEANING AND INSPECTION (Continued)

severely scored, or burned and flaking off. Replace the clutch plates if worn, heavily scored, or cracked. Check the lugs on the clutch plates for wear. The plates should slide freely in the drum. Replace the plates or drum if binding occurs.

Check condition of the annulus gear, direct clutch hub, clutch drum and clutch spring. Replace the gear, hub and drum if worn or damaged. Replace the spring if collapsed, distorted, or cracked.

Be sure the splines and lugs on the gear, drum and hub are in good condition. The clutch plates and discs should slide freely in these components.

Inspect the thrust bearings and spring plate. Replace the plate if worn or scored. Replace the bearings if rough, noisy, brinnelled, or worn.

Inspect the planetary gear assembly and the sun gear and bushings. If either the sun gear or the bushings are damaged, replace the gear and bushings as an assembly. The gear and bushings are not serviced separately.

The planetary carrier and pinions must be in good condition. Also be sure the pinion pins are secure and in good condition. Replace the carrier if worn or damaged.

Inspect the overrunning clutch and race. The race surface should be smooth and free of scores. Replace the overrunning clutch assembly or the race if either assembly is worn or damaged in any way.

Inspect the output shaft and governor components. Replace the shaft pilot bushing and inner bushing if damaged. Replace either shaft bearing if rough or noisy. Replace the bearing snap rings if distorted or cracked.

Check the machined surfaces on the output shaft. These surfaces should be clean and smooth. Very minor nicks or scratches can be smoothed with crocus cloth. Replace the shaft if worn, scored or damaged in any way.

Inspect the output shaft bushings. The small bushing is the intermediate shaft pilot bushing. The large bushing is the overrunning clutch hub bushing. Replace either bushing if scored, pitted, cracked, or worn.

ADJUSTMENTS

BRAKE TRANSMISSION SHIFT INTERLOCK

The park interlock cable is part of the brake/shift lever interlock system. Correct cable adjustment is important to proper interlock operation. The gear shift and park lock cables must both be correctly adjusted in order to shift out of Park.

Park Interlock Cable Adjustment Procedure

- (1) Shift into Park position.

- (2) Turn ignition switch to Accessory position. **Be sure ignition key cylinder is in Accessory position. Cable will not adjust correctly in any other position.**

- (3) Remove shift lever bezel and console screws. Raise bezel and console for access to park interlock cable.

- (4) Pull cable lock button up to release cable (Fig. 257).

- (5) Pull cable forward. Then release cable and press lock button down until it snaps in place.

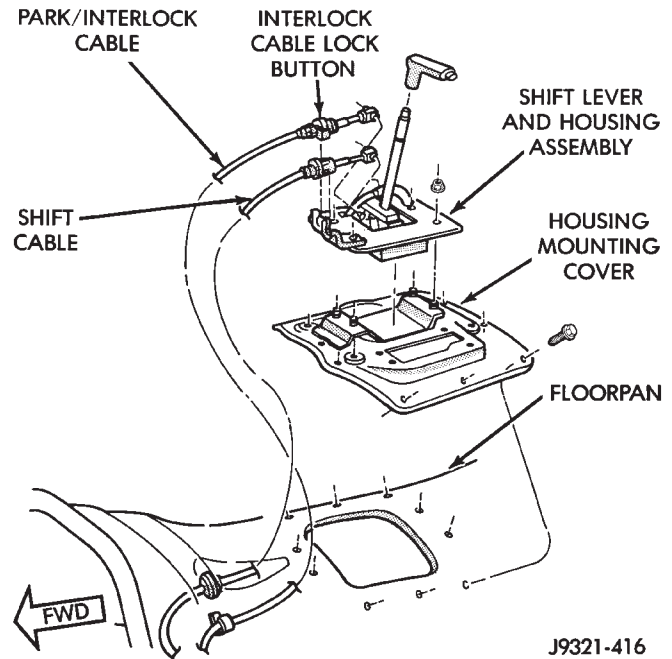


Fig. 257 Shift And Park Lock Cables

BTSI FUNCTION CHECK

- (1) Verify removal of ignition key allowed in park position only.

- (2) When the shift lever is in park, and the shift handle push-button is in the out position, the ignition key cylinder should rotate freely from off to lock. When the shifter is in any other position, the ignition key should not rotate from off to lock.

- (3) Shifting out of park should be possible when the ignition key cylinder is in the off position.

- (4) Shifting out of park should not be possible while applying 25 lb. max. handle push-button force, and ignition key cylinder is in the run or start positions, unless the foot brake pedal is depressed approximately 1/2 inch (12mm).

- (5) Shifting out of park should not be possible when the ignition key cylinder is in the accessory or lock position.

- (6) Shifting between any gears neutral or park may be done without depressing foot brake with ignition switch in run or start positions and vehicle stationary or in motion.

ADJUSTMENTS (Continued)

(7) The floorshifter lever and gate positions should be in alignment with all transmission detent positions.

(8) Engine starts must be possible with floorshift lever in park or neutral gate positions only. Engine starts must not be possible in any other gate positions other than park or neutral.

(9) With floorshift lever handle push-button not depressed and lever detent in:

- PARK POSITION- apply forward force on center of handle and remove pressure. Engine start must be possible.

- PARK POSITION- apply rearward force on center of handle and remove pressure. Engine start must be possible.

- NEUTRAL POSITION- engine start must be possible.

- NEUTRAL POSITION, ENGINE RUNNING AND BRAKES APPLIED- Apply forward force on center of shift handle. Transmission should not be able to shift into reverse detent.

TRANSMISSION THROTTLE VALVE CABLE ADJUSTMENT

The transmission throttle valve is operated by a cam on the throttle lever. The throttle lever is operated by an adjustable cable (Fig. 258). The cable is attached to an arm mounted on the throttle lever shaft. A retaining clip at the engine-end of the cable is removed to provide for cable adjustment. The retaining clip is then installed back onto the throttle valve cable to lock in the adjustment.

A correctly adjusted throttle valve cable will cause the throttle lever on the transmission to move simultaneously with the throttle body lever from the idle position. Proper adjustment will allow simultaneous movement without causing the transmission throttle lever to either move ahead of, or lag behind the lever on the throttle body.

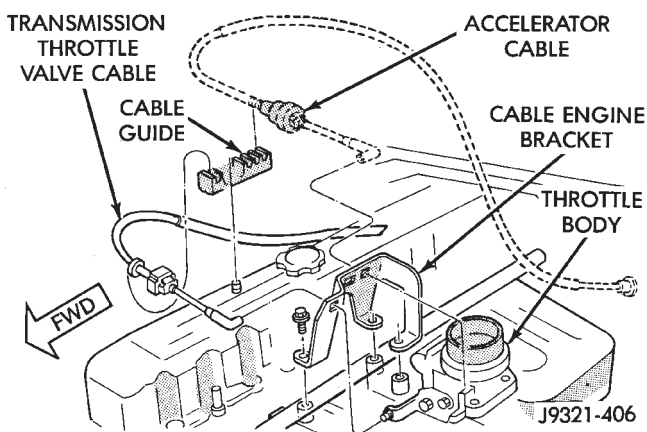
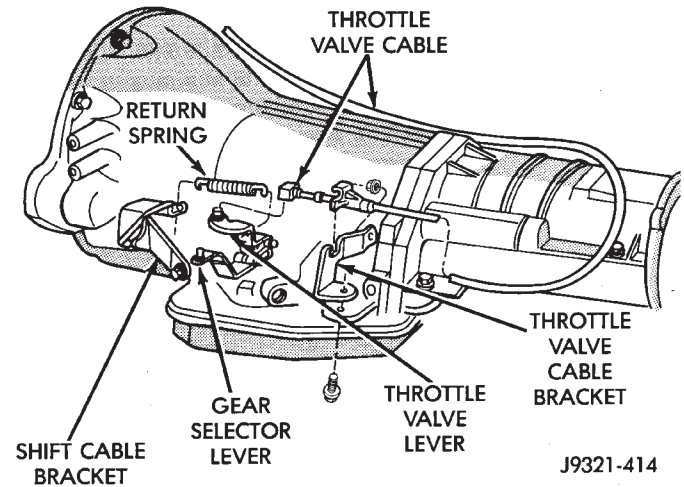


Fig. 258 Throttle Cable Attachment At Engine

Checking Throttle Valve Cable Adjustment

- (1) Turn ignition key to OFF position.
- (2) Remove air cleaner.
- (3) Verify that lever on throttle body is at curb idle position. Then verify that transmission throttle lever (Fig. 259) is also at idle (fully forward) position.



J9321-414

Fig. 259 Throttle Cable Attachment At Transmission

- (4) Slide cable off attachment stud on throttle body lever.

- (5) Compare position of cable end to attachment stud on throttle body lever:

- Cable end and attachment stud should be aligned (or centered on one another) to within 1 mm (0.039 in.) in either direction.

- If cable end and attachment stud are misaligned (off center), cable will have to be adjusted as described in Throttle Valve Cable Adjustment procedure.

- (6) Reconnect cable end to attachment stud. Then with aid of a helper, observe movement of transmission throttle lever and lever on throttle body.

- If both levers move simultaneously from idle to half-throttle and back to idle position, adjustment is correct.

- If transmission throttle lever moves ahead of, or lags behind throttle body lever, cable adjustment will be necessary. Or, if throttle body lever prevents transmission lever from returning to closed position, cable adjustment will be necessary.

Throttle Valve Cable Adjustment Procedure

- (1) Turn ignition switch to OFF position.
- (2) Remove air cleaner if necessary.
- (3) Disconnect cable end from attachment stud. **Carefully slide cable off stud. Do not pry or pull cable off.**
- (4) Verify that transmission throttle lever is in fully closed position. Then be sure lever on throttle body is at curb idle position.

ADJUSTMENTS (Continued)

- (5) Insert a small screwdriver under edge of retaining clip and remove retaining clip.
- (6) Center cable end on attachment stud to within 1 mm (0.039 in.).
- (7) Install retaining clip onto cable housing.
- (8) Check cable adjustment. Verify transmission throttle lever and lever on throttle body move simultaneously.

GEARSHIFT CABLE

Check adjustment by starting the engine in Park and Neutral. Adjustment is OK if the engine starts only in these positions. Adjustment is incorrect if the engine starts in one but not both positions. If the engine starts in any position other than Park or Neutral, or if the engine will not start at all, the park/neutral position switch may be faulty.

Gearshift Adjustment Procedure

- (1) Shift transmission into Park.
- (2) Raise vehicle.
- (3) Release cable adjuster clamp (at transmission end of cable) to unlock cable.
- (4) Unsnap cable from cable mounting bracket on transmission (Fig. 260).
- (5) Slide cable eyelet off transmission shift lever.
- (6) Verify transmission shift lever is in Park detent by moving lever fully rearward. Last rearward detent is Park position.
- (7) Verify positive engagement of transmission park lock by attempting to rotate propeller shaft. Shaft will not rotate when park lock is engaged.
- (8) Slide cable eyelet onto transmission shift lever.
- (9) Snap shift cable adjuster into mounting bracket on transmission.
- (10) Lock shift cable by pressing cable adjuster clamp down until it snaps into place.
- (11) Lower vehicle and check engine starting. Engine should start only in Park and Neutral.

FRONT BAND ADJUSTMENT

The front (kickdown) band adjusting screw is located on the left side of the transmission case above the manual valve and throttle valve levers.

- (1) Raise vehicle.
- (2) Loosen band adjusting screw locknut (Fig. 261). Then back locknut off 3-5 turns. Be sure adjusting screw turns freely in case. Apply lubricant to screw threads if necessary.
- (3) Tighten band adjusting screw to 8 N·m (72 in. lbs.) torque with Inch Pound Torque Wrench C-3380-A, a 3-in. extension and 5/16 socket.

CAUTION: If Adapter C-3705 is needed to reach the adjusting screw (Fig. 262), tighten the screw to only 5 N·m (47-50 in. lbs.) torque.

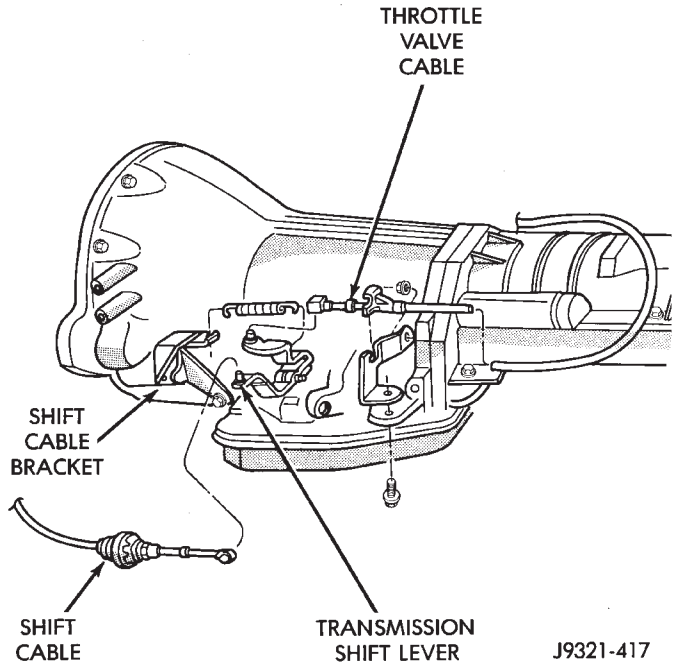


Fig. 260 Shift Cable Attachment At Transmission—Typical

- (4) Back off front band adjusting screw 2-7/8 turns.
- (5) Hold adjuster screw in position and tighten locknut to 41 N·m (30 ft. lbs.) torque.
- (6) Lower vehicle.

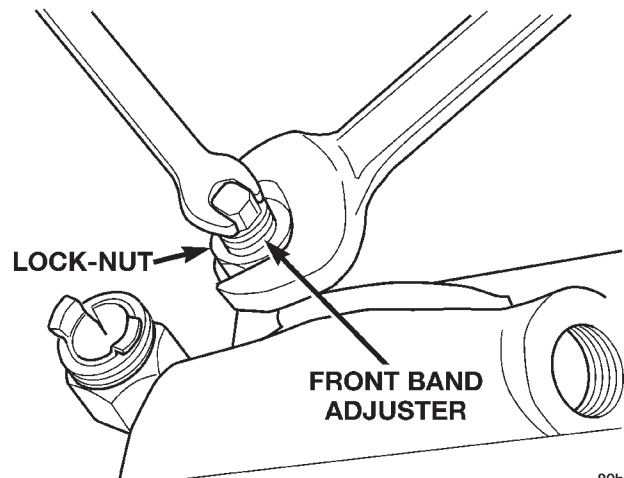


Fig. 261 Front Band Adjustment Screw Location

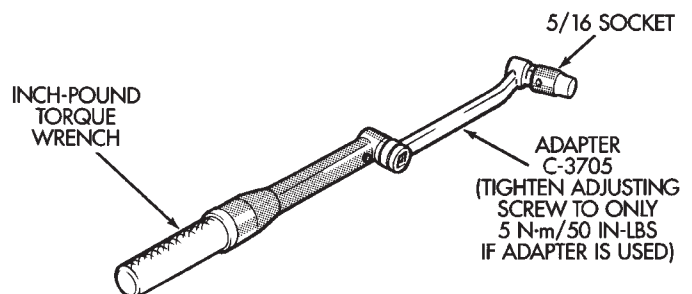


Fig. 262 Band Adjustment Adapter Tool

ADJUSTMENTS (Continued)

REAR BAND ADJUSTMENT

The transmission oil pan must be removed for access to the rear band adjusting screw.

- (1) Raise vehicle.
- (2) Remove transmission oil pan and drain fluid.
- (3) Loosen band adjusting screw locknut 5-6 turns. Be sure adjusting screw turns freely in lever.
- (4) Tighten adjusting screw to 8 N·m (72 in. lbs.) torque (Fig. 263).
- (5) Back off adjusting screw 2 turns.
- (6) Hold adjusting screw in place and tighten locknut to 34 N·m (25 ft. lbs.) torque.
- (7) Position new gasket on oil pan and install pan on transmission. Tighten pan bolts to 17 N·m (13 ft. lbs.) torque.
- (8) Lower vehicle and refill transmission with Mopar® ATF Plus, Type 7176 fluid.

VALVE BODY

CONTROL PRESSURE ADJUSTMENTS

There are two control pressure adjustments on the valve body;

- Line Pressure
- Throttle Pressure

LOW-REVERSE BAND ADJUSTMENT

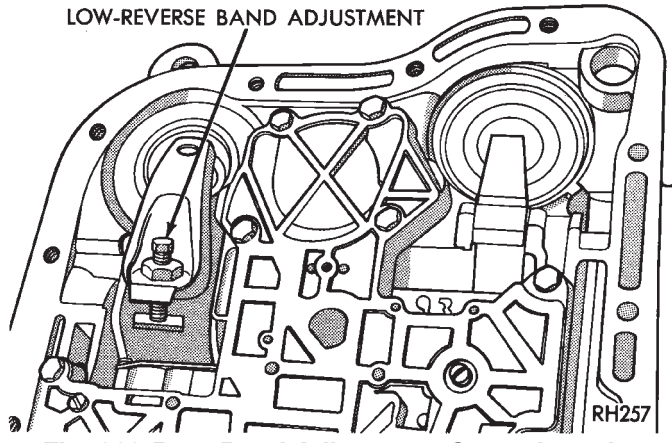


Fig. 263 Rear Band Adjustment Screw Location

Line and throttle pressures are interdependent because each affects shift quality and timing. As a result, both adjustments must be performed properly and in the correct sequence. Adjust line pressure first and throttle pressure last.

LINE PRESSURE ADJUSTMENT

Measure distance from the valve body to the inner edge of the adjusting screw with an accurate steel scale (Fig. 264).

Distance should be 33.4 mm (1-5/16 in.).

If adjustment is required, turn the adjusting screw in, or out, to obtain required distance setting.

NOTE: The 33.4 mm (1-5/16 in.) setting is an approximate setting. Manufacturing tolerances may make it necessary to vary from this dimension to obtain desired pressure.

One complete turn of the adjusting screw changes line pressure approximately 1-2/3 psi (9 kPa).

Turning the adjusting screw counterclockwise increases pressure while turning the screw clockwise decreases pressure.

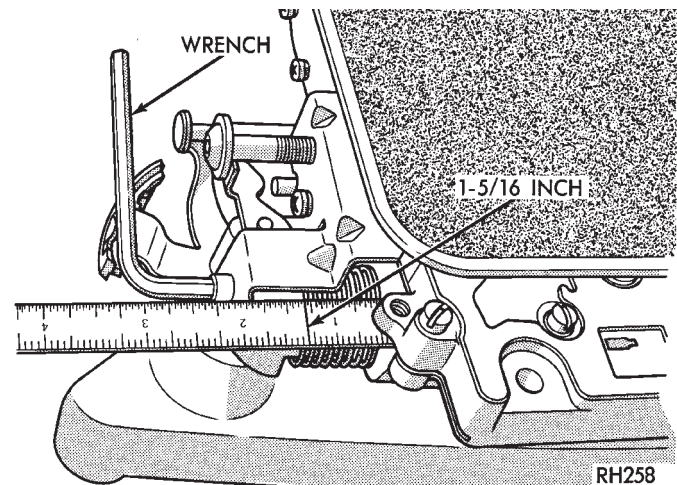


Fig. 264 Line Pressure Adjustment

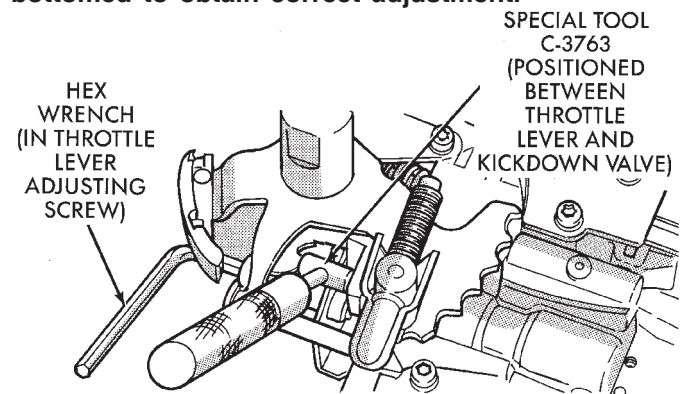
THROTTLE PRESSURE ADJUSTMENT

Insert Gauge Tool C-3763 between the throttle lever cam and the kickdown valve stem (Fig. 265).

Push the gauge tool inward to compress the kickdown valve against the spring and bottom the throttle valve.

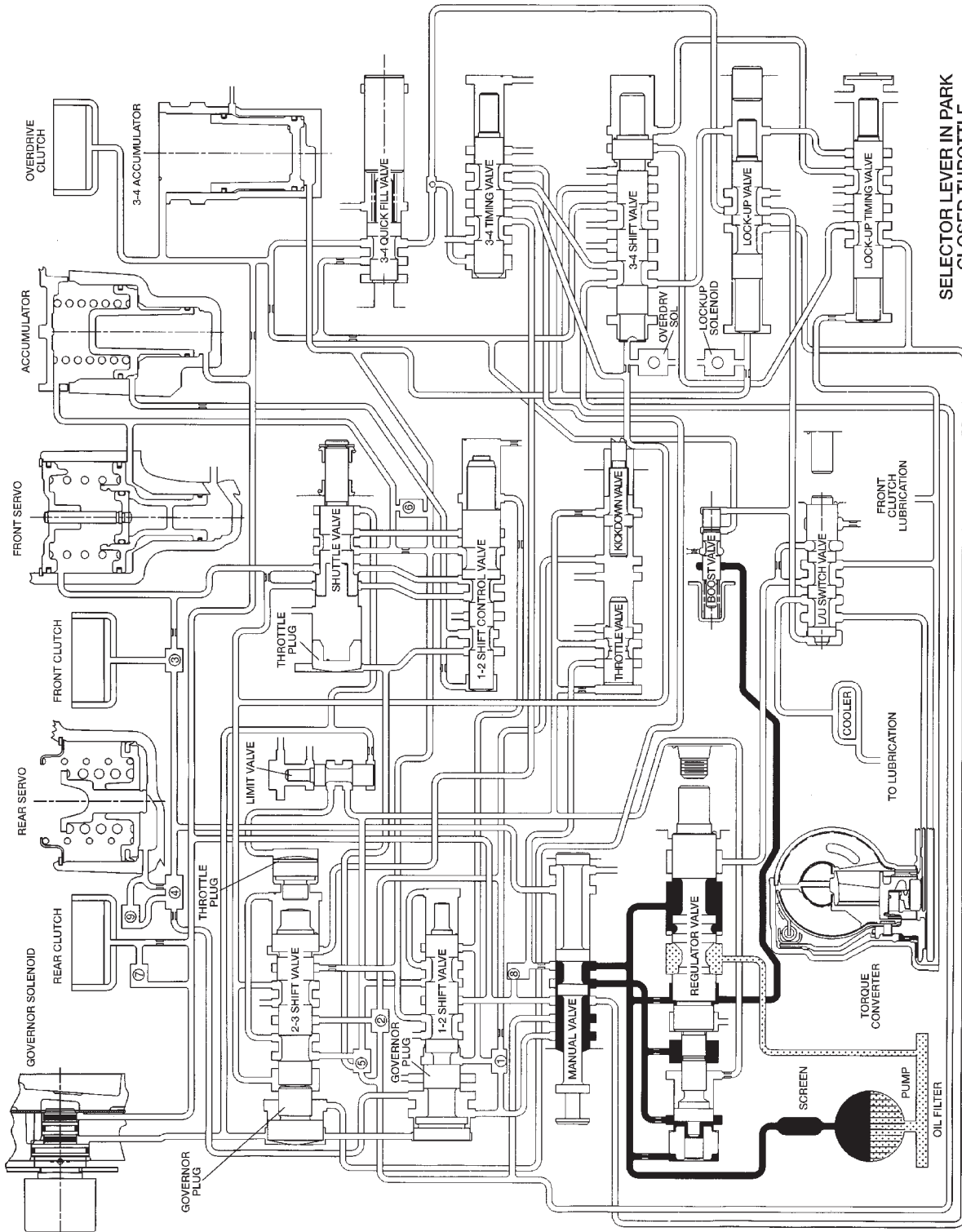
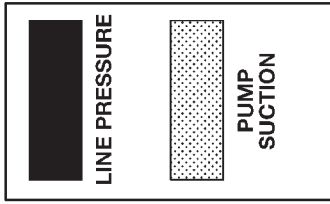
Maintain pressure against kickdown valve spring. Turn throttle lever stop screw until the screw head touches throttle lever tang and the throttle lever cam touches gauge tool.

NOTE: The kickdown valve spring must be fully compressed and the kickdown valve completely bottomed to obtain correct adjustment.



J9521-109
Fig. 265 Throttle Pressure Adjustment

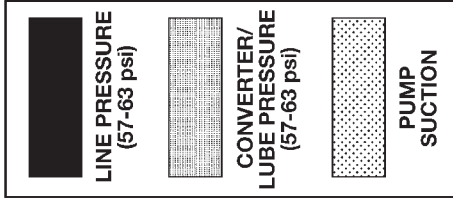
SCHEMATICS AND DIAGRAMS
HYDRAULIC SCHEMATICS



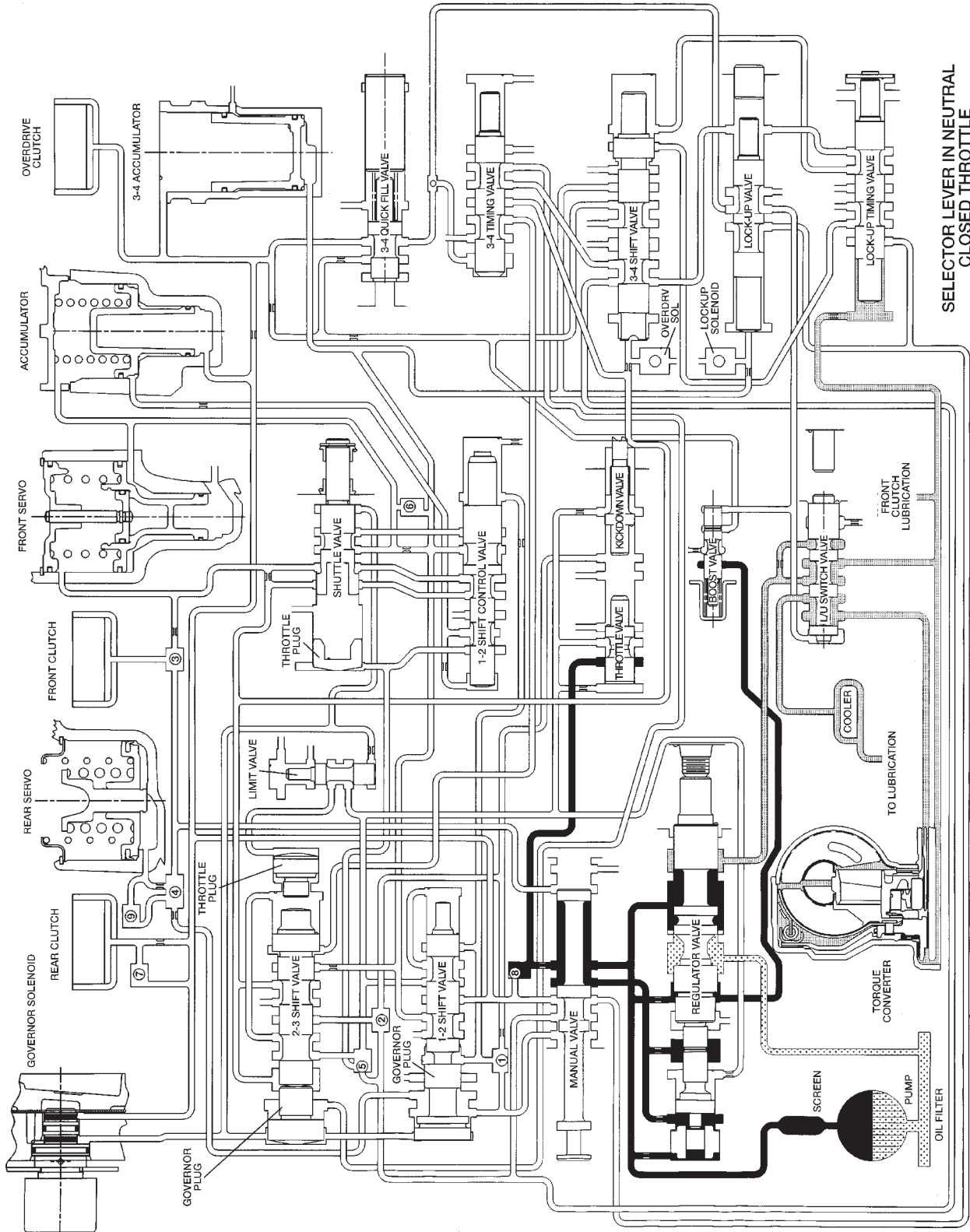
80abd7e

HYDRAULIC FLOW IN PARK

SCHEMATICS AND DIAGRAMS (Continued)

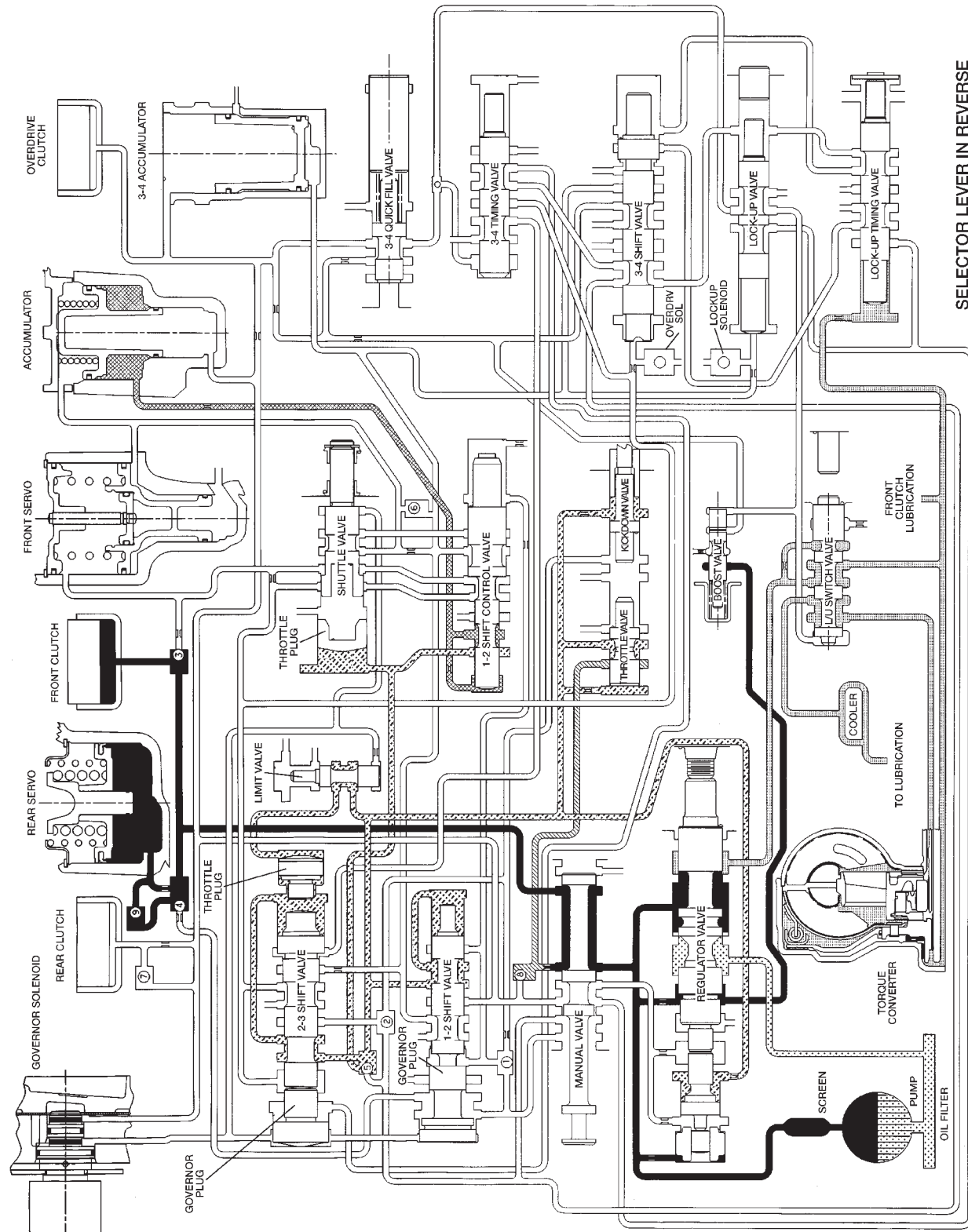
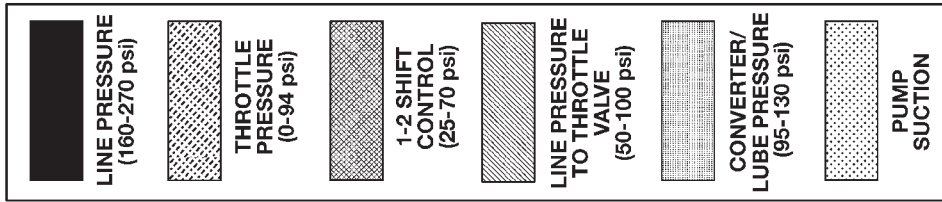


80abfd7f



HYDRAULIC FLOW IN NEUTRAL

SCHEMATICS AND DIAGRAMS (Continued)

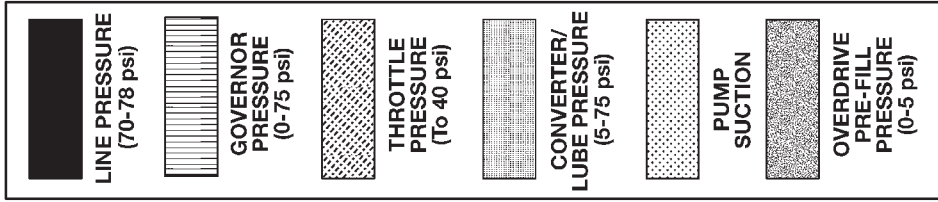


SELECTOR LEVER IN REVERSE

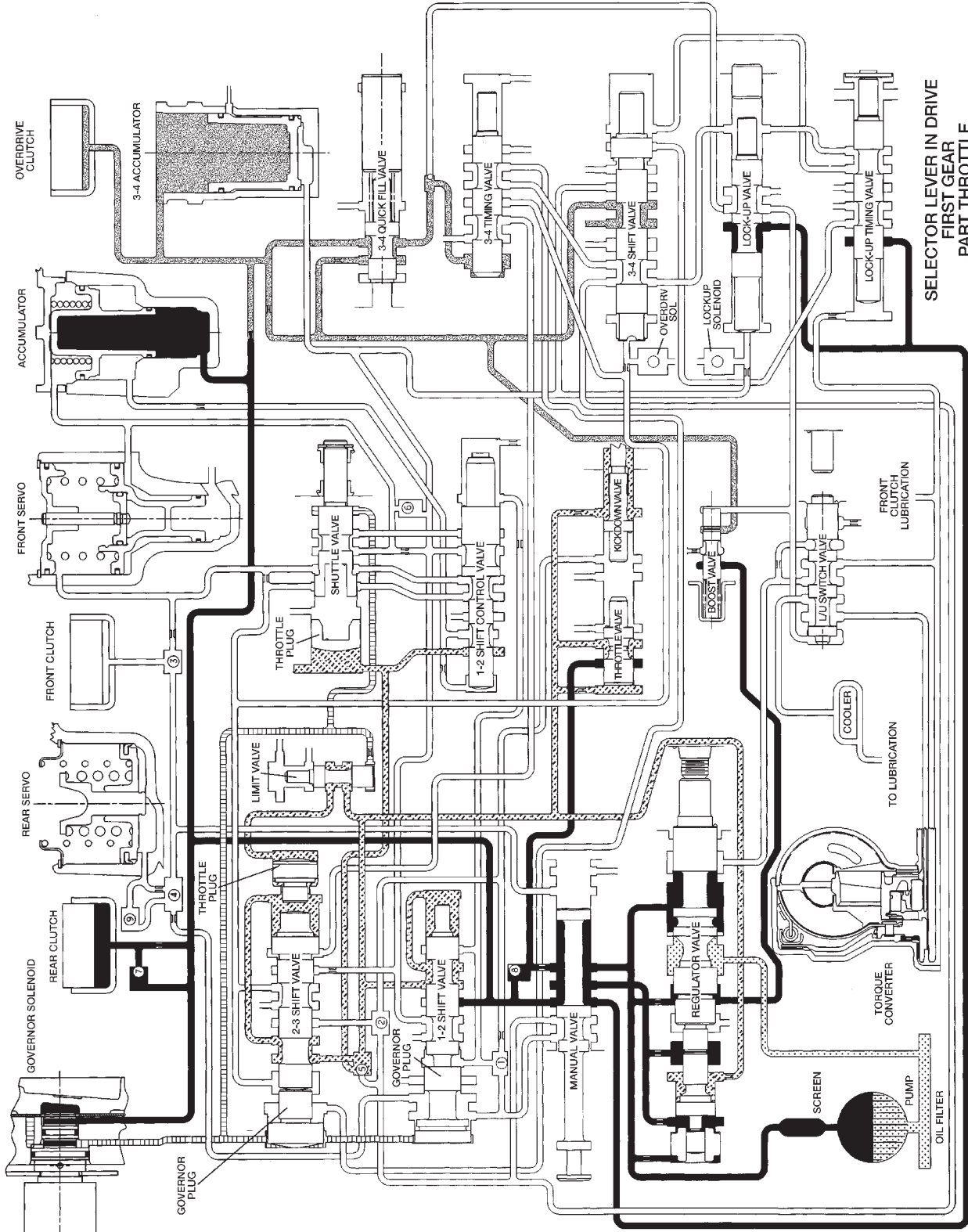
HYDRAULIC FLOW IN REVERSE

80abfd80

SCHEMATICS AND DIAGRAMS (Continued)

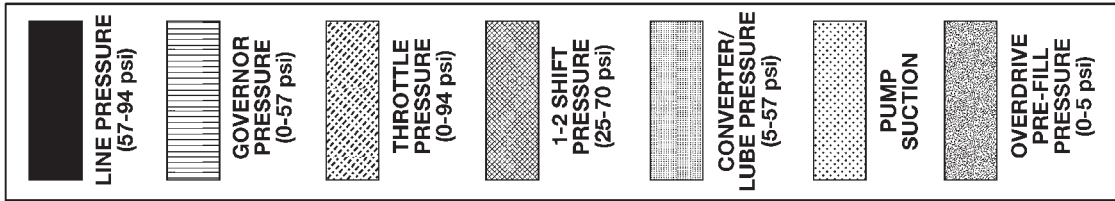


80abrd83

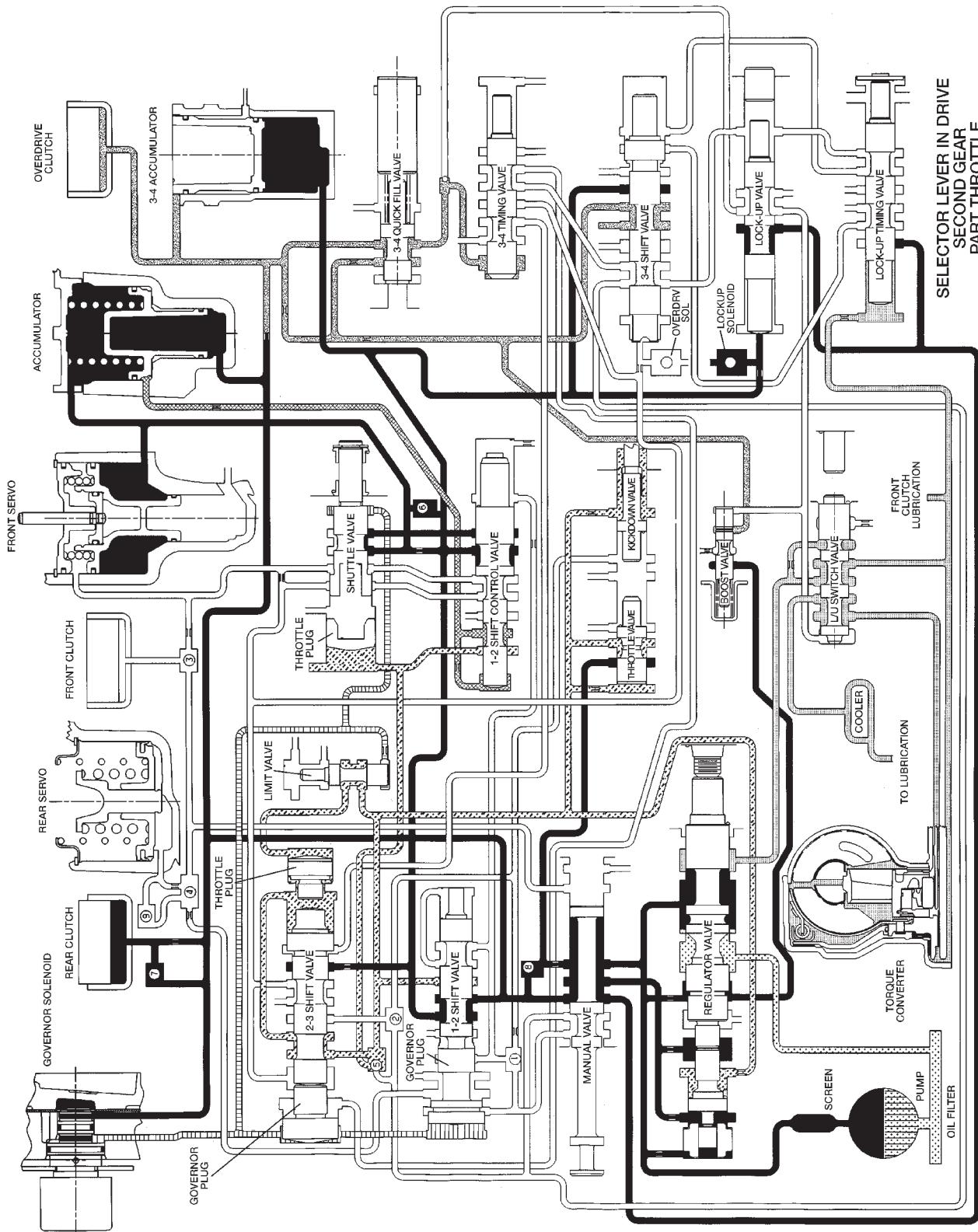


HYDRAULIC FLOW IN DRIVE FIRST GEAR

SCHEMATICS AND DIAGRAMS (Continued)

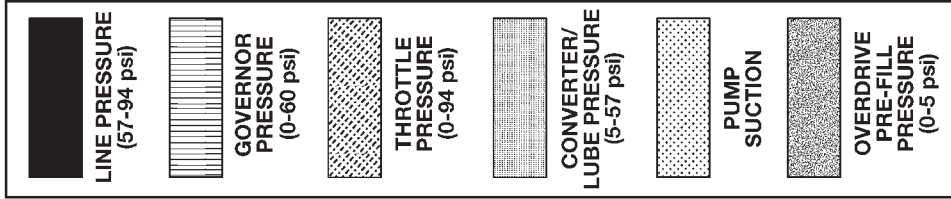


80ubrfd84

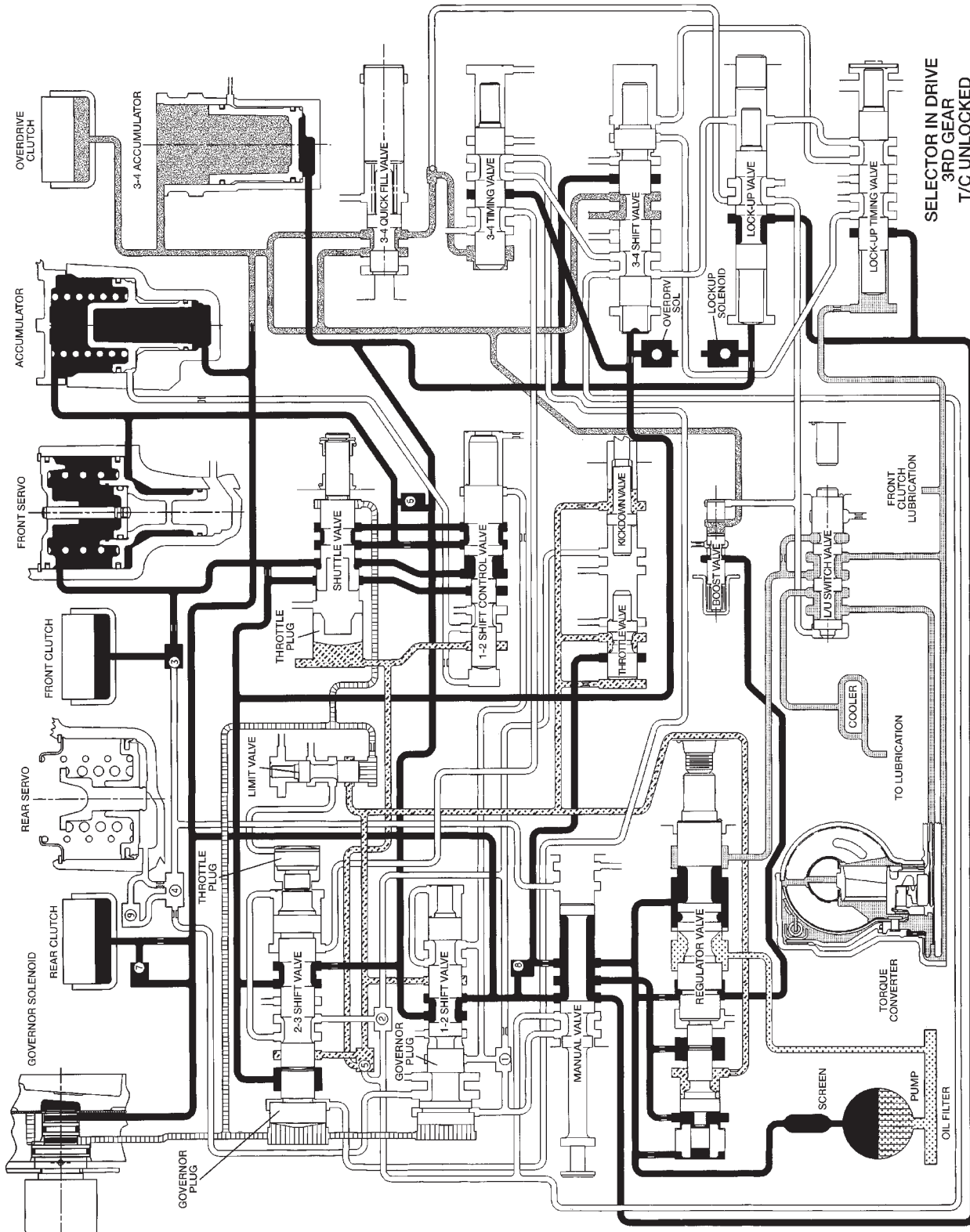


HYDRAULIC FLOW IN DRIVE SECOND GEAR

SCHEMATICS AND DIAGRAMS (Continued)

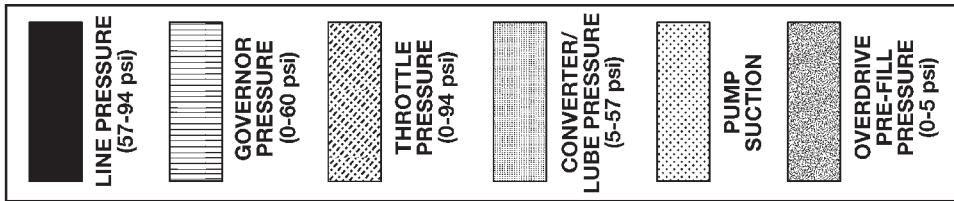


80dabf885

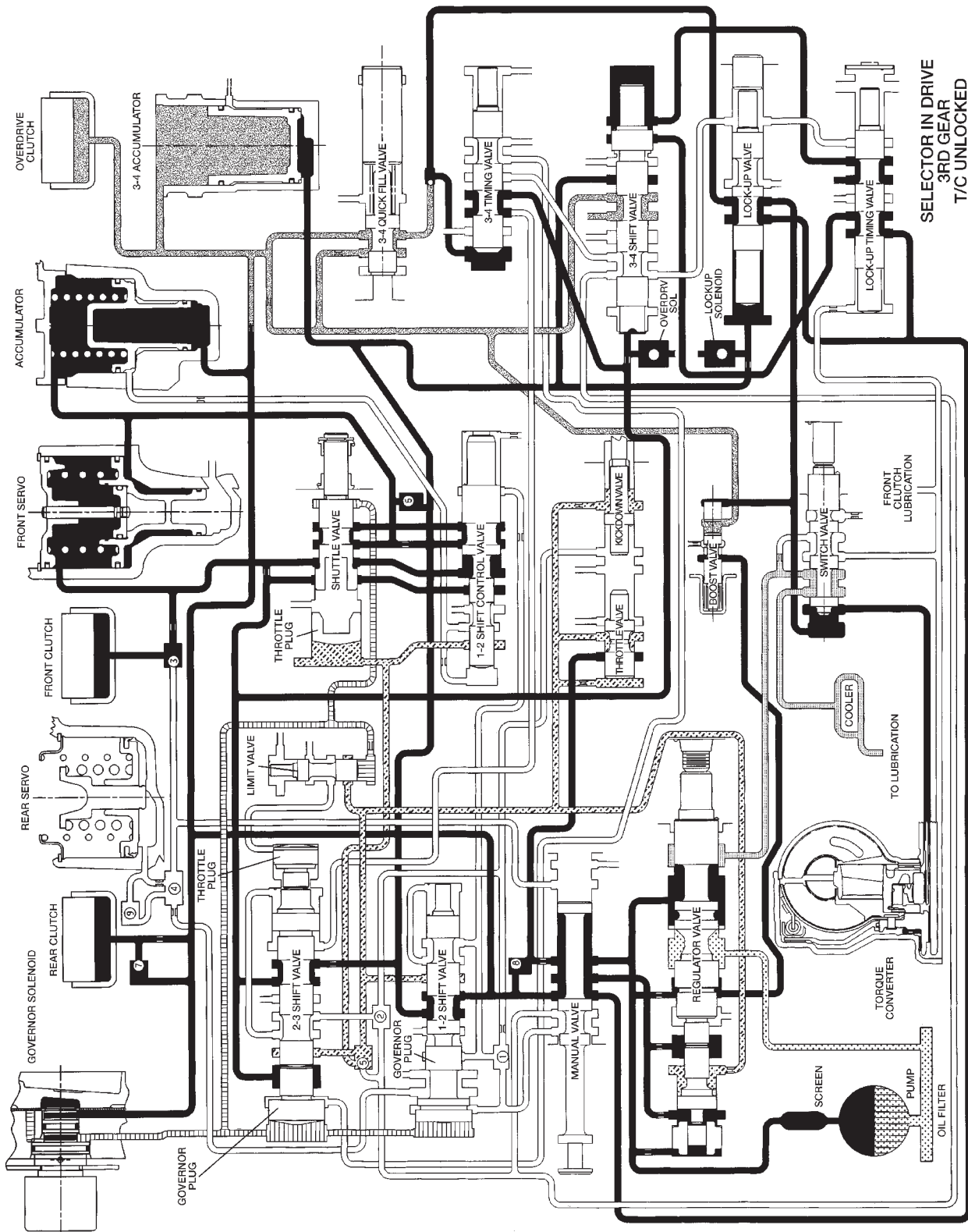


HYDRAULIC FLOW IN DRIVE THIRD GEAR (CONVERTER CLUTCH NOT APPLIED)

SCHEMATICS AND DIAGRAMS (Continued)

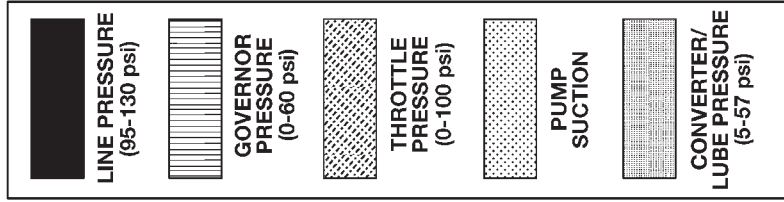


80abrid8c

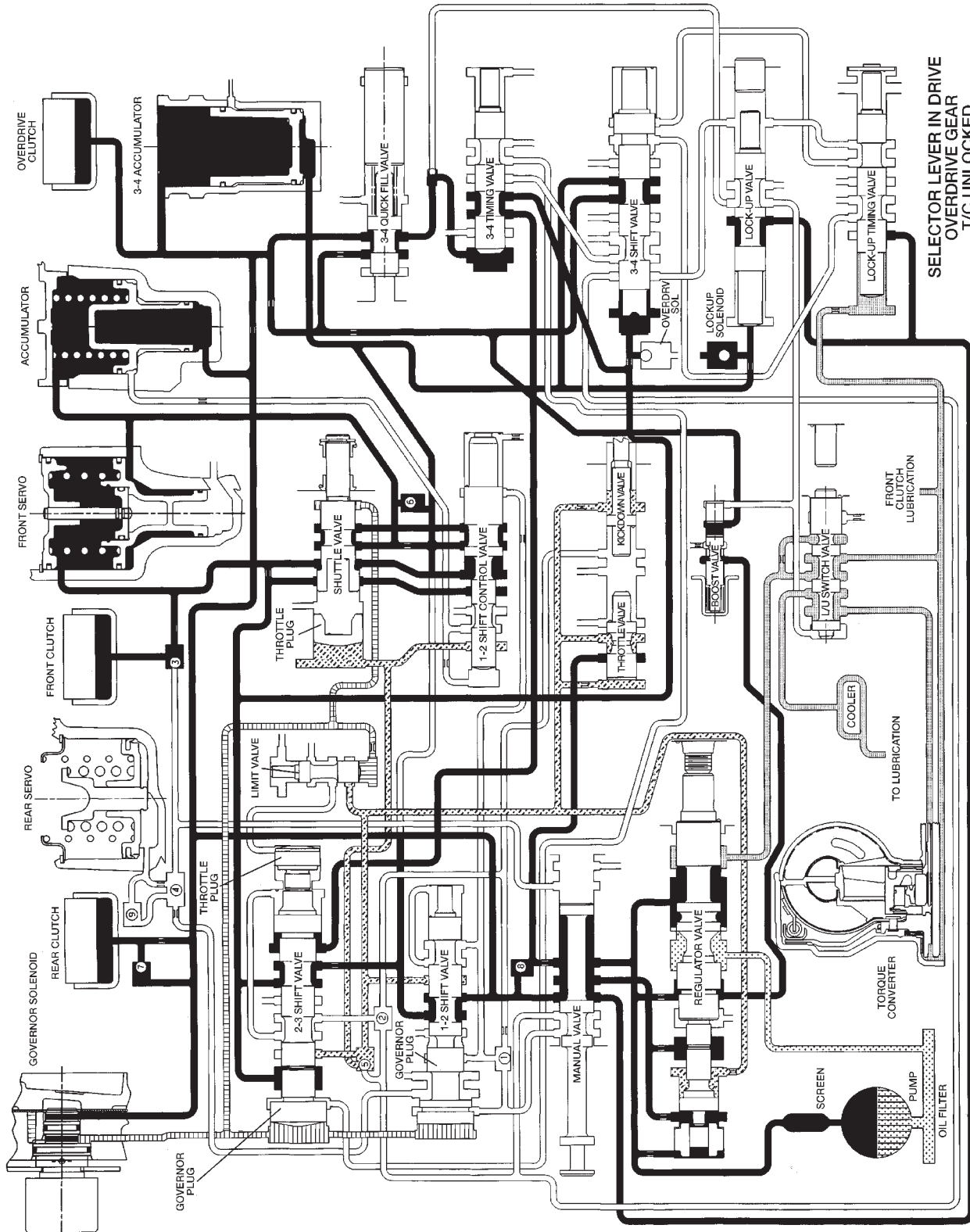


HYDRAULIC FLOW IN DRIVE THIRD GEAR (CONVERTER CLUTCH APPLIED)

SCHEMATICS AND DIAGRAMS (Continued)



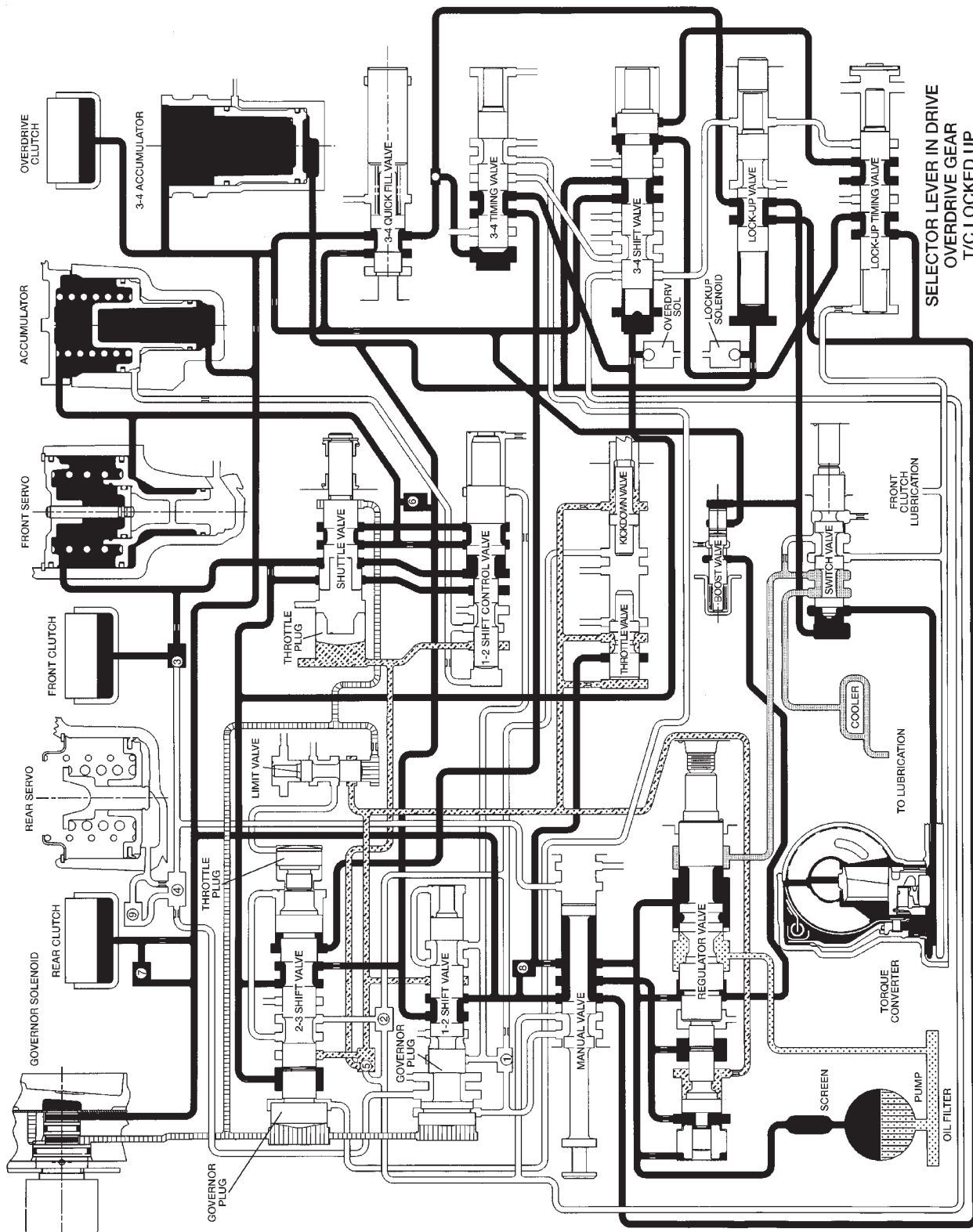
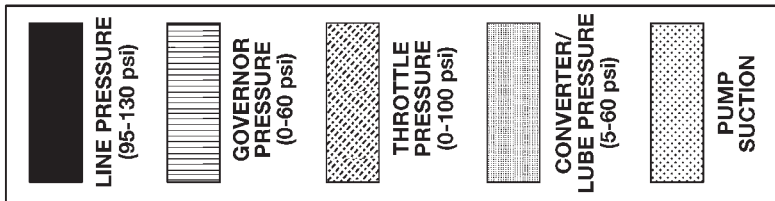
80abfd68



SELECTOR LEVER IN DRIVE
OVERDRIVE GEAR
T/C UNLOCKED

HYDRAULIC FLOW IN DRIVE FOURTH GEAR (CONVERTER CLUTCH NOT APPLIED)

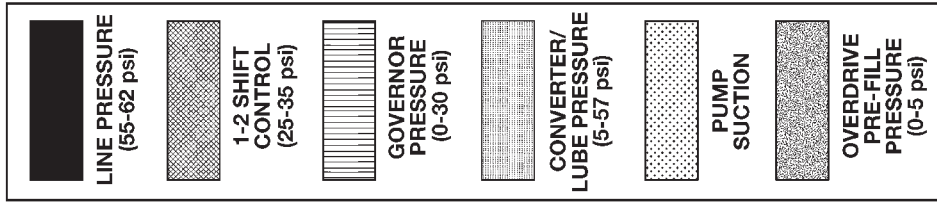
SCHEMATICS AND DIAGRAMS (Continued)



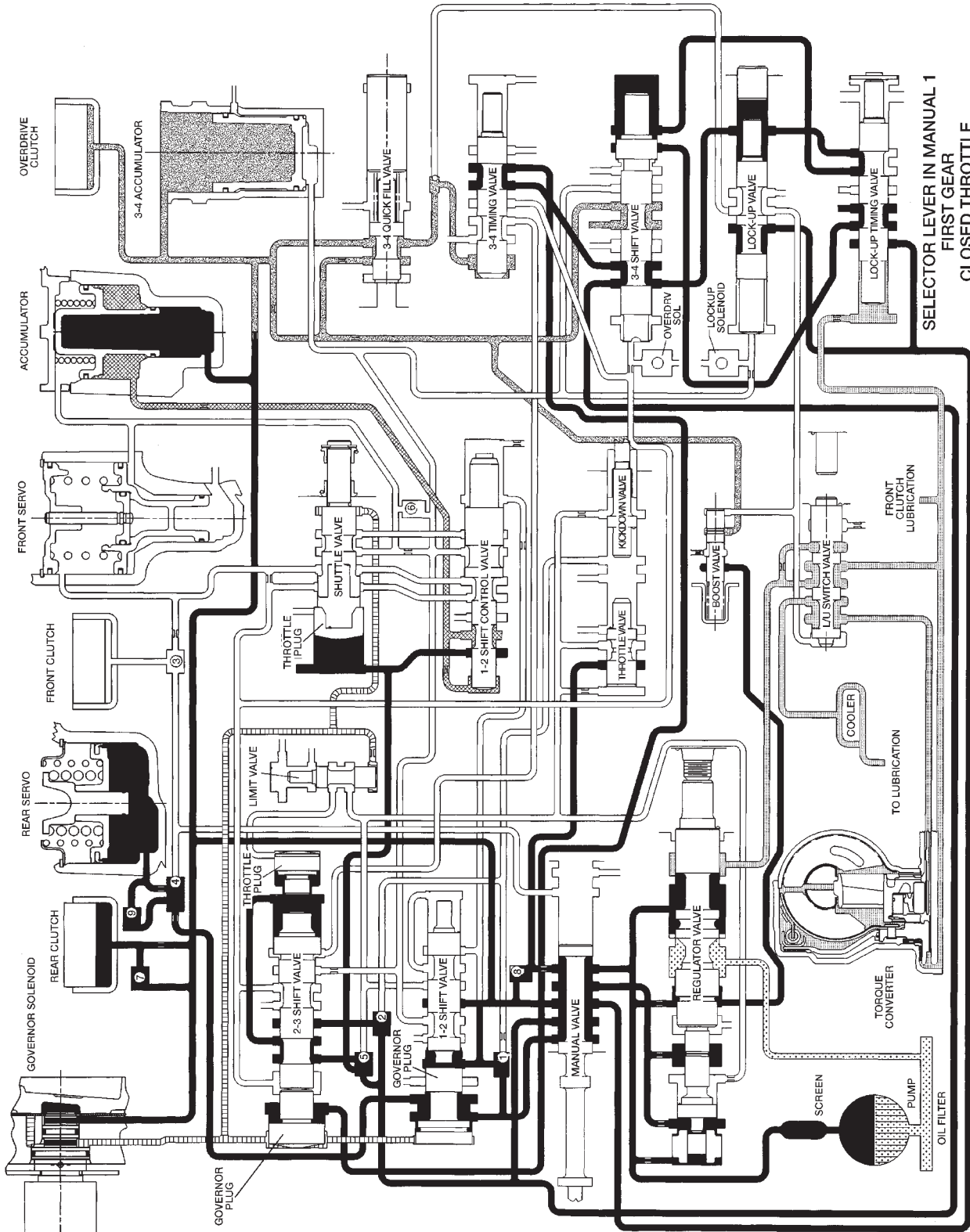
80abfd87

HYDRAULIC FLOW IN DRIVE FOURTH GEAR (CONVERTER CLUTCH APPLIED)

SCHEMATICS AND DIAGRAMS (Continued)

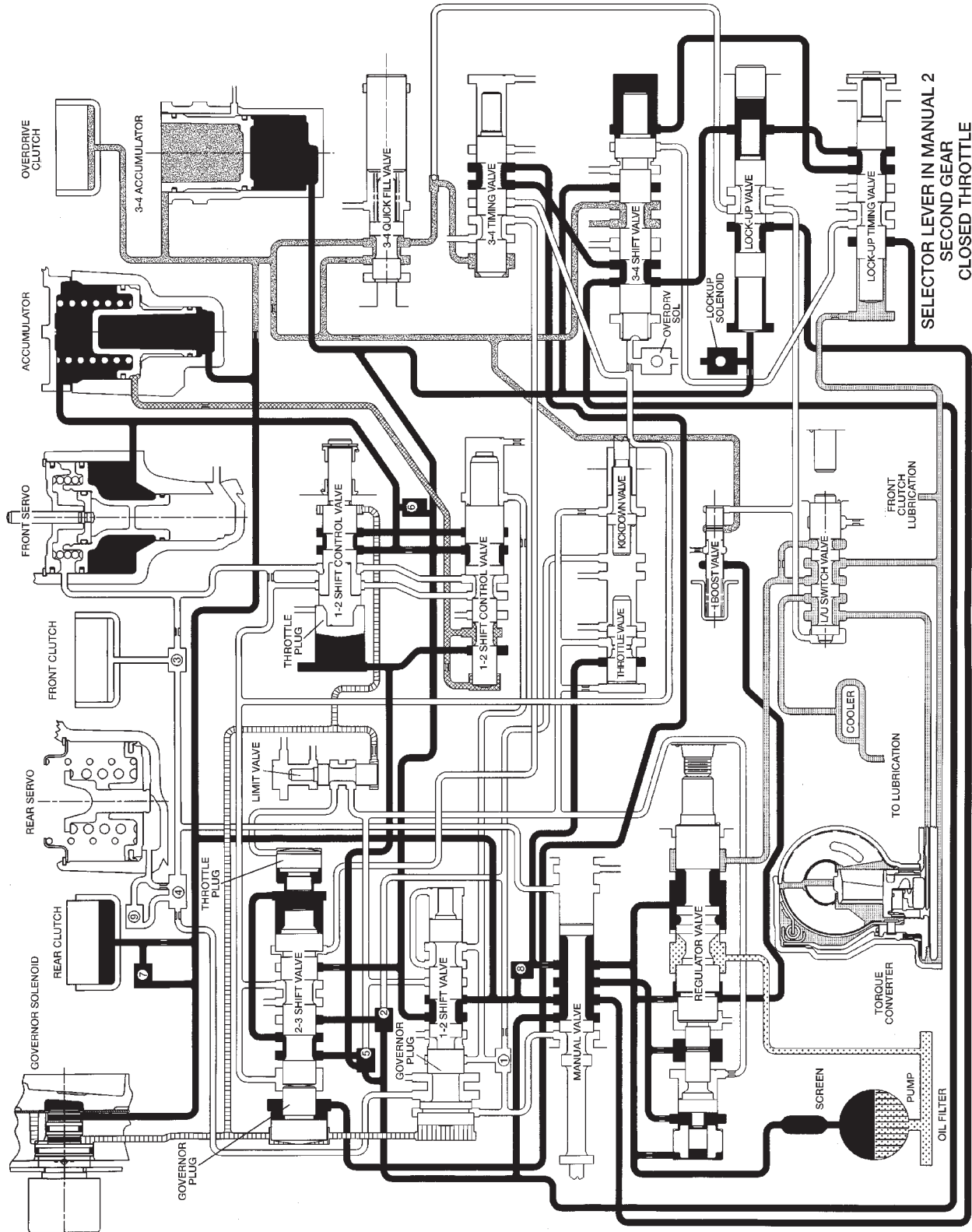
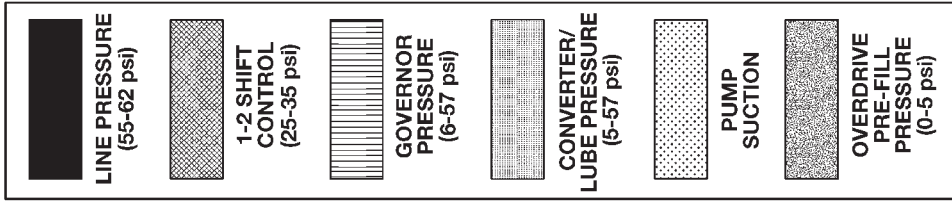


80abfd88



HYDRAULIC FLOW IN MANUAL LOW (1)

SCHEMATICS AND DIAGRAMS (Continued)

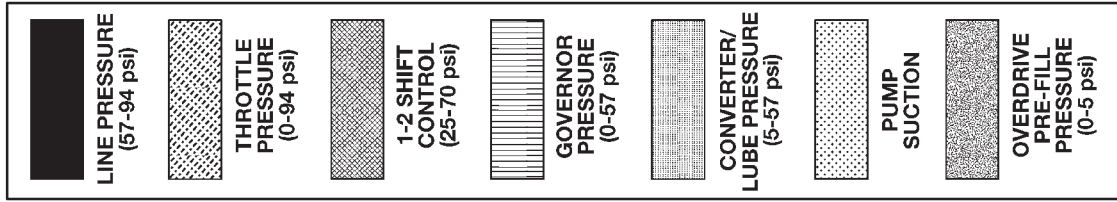


SELECTOR LEVER IN MANUAL 2
SECOND GEAR
CLOSED THROTTLE

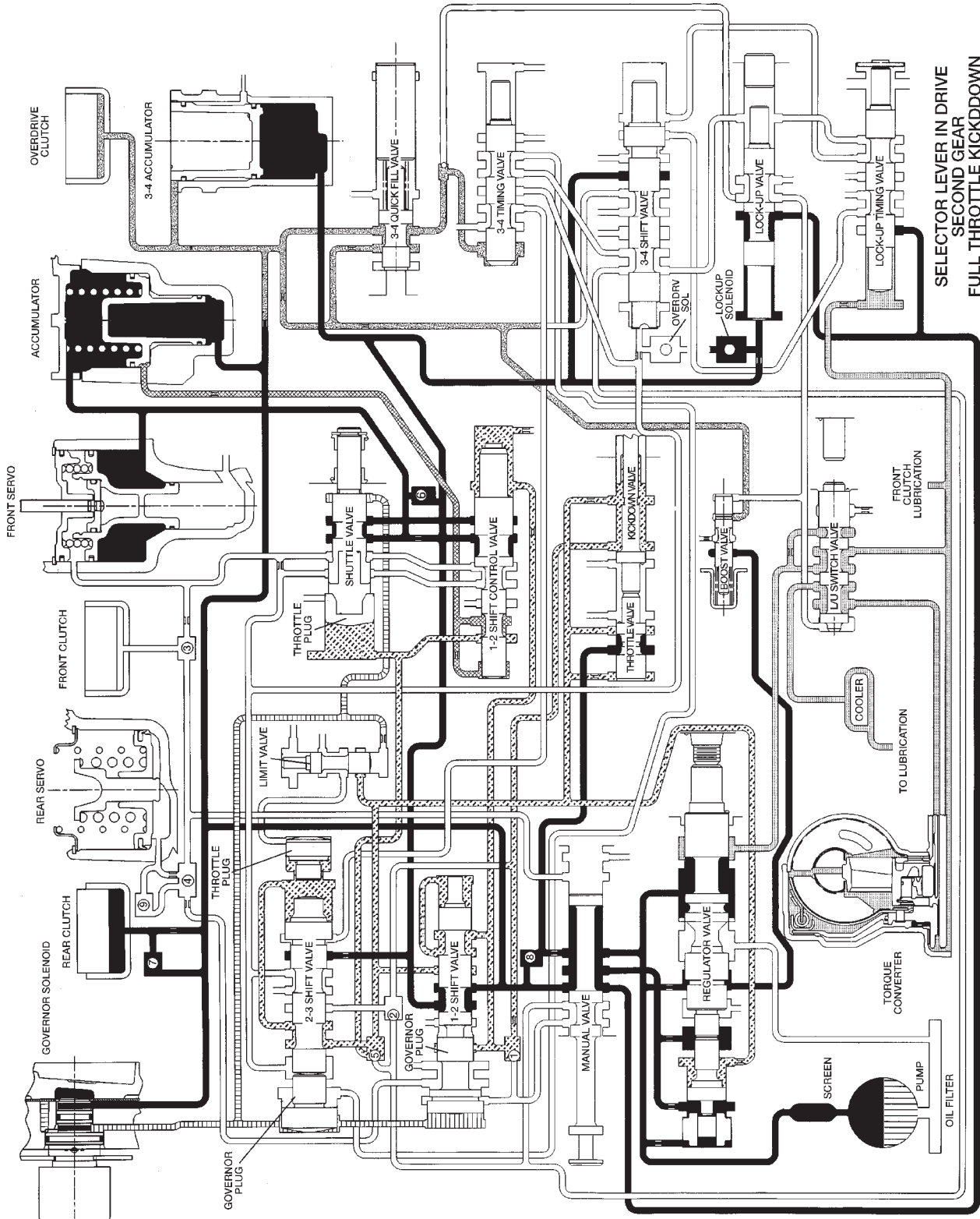
HYDRAULIC FLOW IN MANUAL SECOND (2)

80abfd89

SCHEMATICS AND DIAGRAMS (Continued)



80abfd8a



SELECTOR LEVER IN DRIVE
SECOND GEAR
FULL THROTTLE KICKDOWN

HYDRAULIC FLOW DURING FULL THROTTLE 3-2 DOWNSHIFT (PASSING GEAR)

SPECIFICATIONS

RE TRANSMISSION

GENERAL

Oil pump gear tip clearance	0.089-0.190 mm	0.004-0.008 in.
Planetary end play	0.150-1.22 mm	0.006-0.048 in.
Input shaft end play	0.86-2.13 mm	0.034-0.084 in.
Clutch pack clearance/Front 3-disc.	1.78-3.28mm	0.070-0.129 in.
Clutch pack clearance/Rear 4-disc.	0.64-1.14 mm	0.025-0.045 in.
Overdrive clutch disc usage	4 discs	
Direct clutch disc usage	8 discs	
Front clutch spring usage	9 spring	
Band adjustment from 72 in. lbs. Front band Rear band	Back off 2-7/8 turns Back off 2 turns	
Recommended fluid	Mopar® ATF Plus, type 7176	

TORQUE

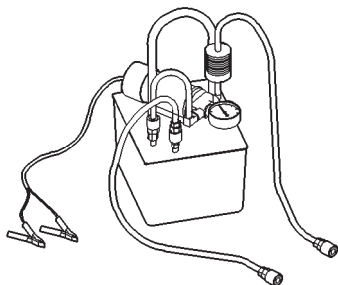
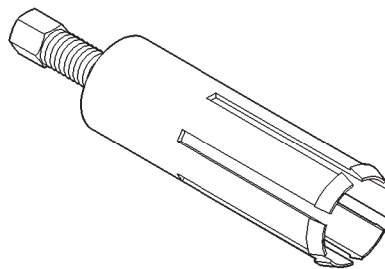
DESCRIPTION	TORQUE
Bolt, torque convertor31 N·m (23 ft. lbs.)
Bolt/nut, crossmember68 N·m (50 ft. lbs.)
Bolt, driveplate to crankshaft75 N·m (55 ft. lbs.)
Plug, front band reaction17 N·m (13 ft. lbs.)
Locknut, front band adj.34 N·m (25 ft. lbs.)
Switch, park/neutral34 N·m (25 ft. lbs.)
Bolt, fluid pan.17 N·m (13 ft. lbs.)
Bolt, oil pump20 N·m (15 ft. lbs.)
Bolt, overrunning clutch cam17 N·m (13 ft. lbs.)
Bolt, O/D to trans.34 N·m (25 ft. lbs.)
Bolt, O/D piston retainer17 N·m (13 ft. lbs.)
Plug, pressure test port14 N·m (10 ft. lbs.)
Bolt, reaction shaft support20 N·m (15 ft. lbs.)
Locknut, rear band41 N·m (30 ft. lbs.)
Bolt, speedometer adapter11 N·m (8 ft. lbs.)
Screw, fluid filter4 N·m (35 in. lbs.)
Bolt, valve body to case12 N·m (100 in. lbs.)

SPECIFICATIONS (Continued)**THRUST WASHER/SPACER/SNAP RING DIMENSIONS**

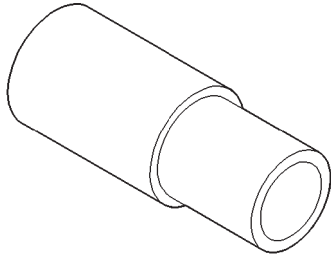
Front clutch thrust washer (reaction shaft support hub)	1.55 mm 2.15 mm	0.061 in. 0.084 in. 0.102 in.
Rear clutch thrust washer (clutch retainer)	1.55 mm	0.061 in.
Output shaft thrust plate (output shaft pilot hub)	1.5-1.6 mm	0.060-0.063 in.
Output shaft thrust washer (rear clutch hub)	1.3-1.4 mm 1.75-1.8 mm 2.1-2.2 mm	0.052-0.054 in. 0.068-0.070 in. 0.083-0.085 in.
Rear clutch pack snap ring	1.5-1.6 mm 1.9-1.95 mm	0.060-0.062 in. 0.074-0.076 in.
Planetary geartrain snap ring (at front of output shaft)	1.4-1.5 mm 1.6-1.7 mm	0.055-0.059 in. 0.062-0.066 in.
Overdrive piston thrust plate	Thrust plate and spacer are select fit components. Refer to size charts and	
Intermediate shaft spacer	selection procedures in Overdrive Unit disassembly and assembly section.	

PRESSURE TEST

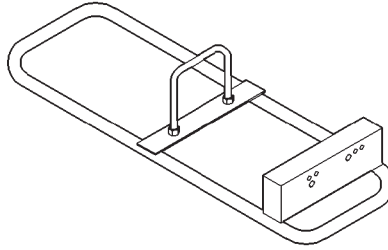
Overdrive clutch	Fourth gear only	Pressure should be 469-496 kPa (68-72 psi) with closed throttle and increase to 620-896 kPa (90-130 psi) at 1/2 to 3/4 throttle.
Line pressure (at accumulator)	Closed throttle	372-414 kPa (54-60 psi).
Front servo	Third gear only	No more than 21 kPa (3 psi) lower than line pressure.
Rear servo	1 range R range	No more than 21 kPa (3 psi) lower than line pressure. 1103 kPa (160 psi) at idle, builds to 1862 kPa (270 psi) at 1600 rpm.
Governor	D range closed throttle	Pressure should respond smoothly to changes in mph and return to 0-7 kPa (0-1.5 psi) when stopped with transmission in D, 1, 2. Pressure above 7 kPa (1.5 psi) at stand still will prevent transmission from downshifting.

SPECIAL TOOLS**RE TRANSMISSION***Oil Cooler Flusher—6906**Remover—6957*

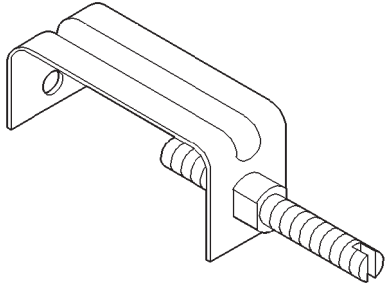
SPECIAL TOOLS (Continued)



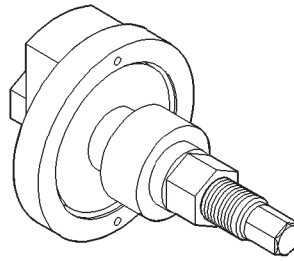
Installer—6951



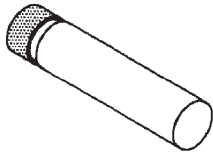
Transmission Repair Stand—C-3750-B



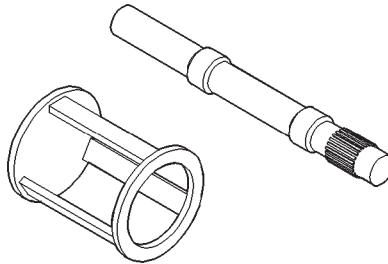
Retainer, Detent Ball and Spring—6583



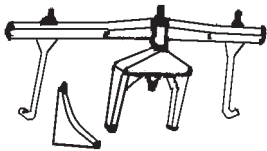
Spring Compressor—C-3863-A



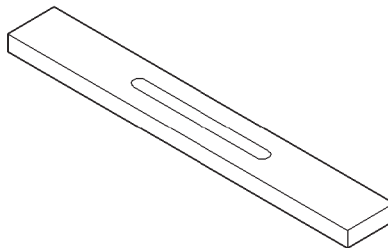
Gauge Block—6312



Spring Compressor and Alignment Shaft—6227

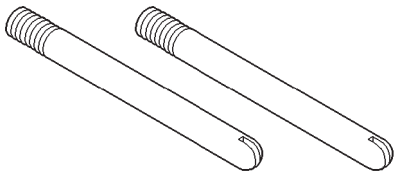


Fixture, Engine Support—C-3487-A

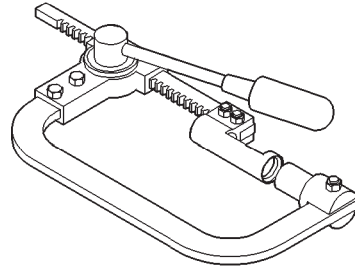


Gauge Bar—6311

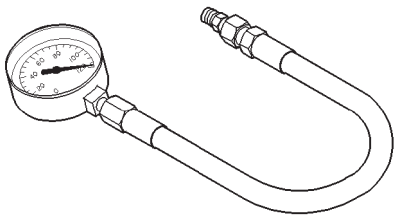
SPECIAL TOOLS (Continued)



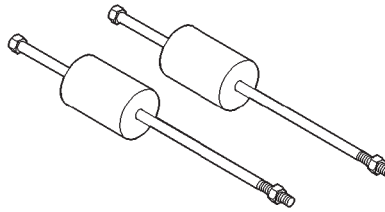
Extension Housing Pilot—C-3288-B



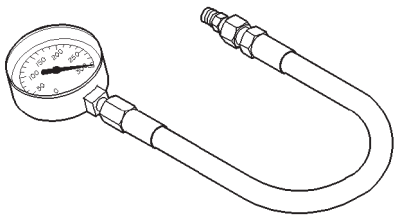
Spring Compressor—C-3422-B



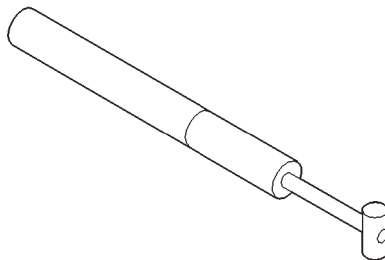
Pressure Gauge—C-3292



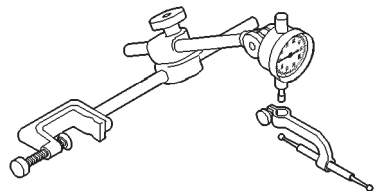
Puller, Slide Hammer—C-3752



Pressure Gauge—C-3293SP

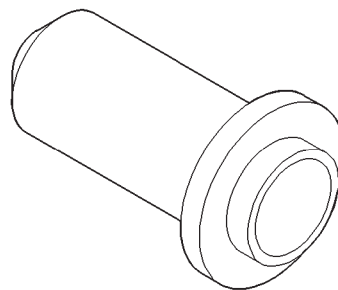


Gauge, Throttle Setting—C-3763



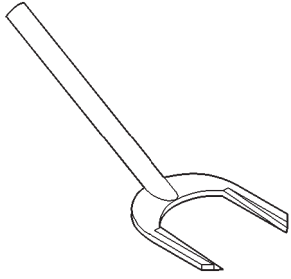
8011d42b

Dial Indicator—C-3339

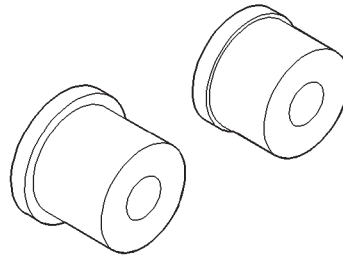


Seal Installer—C-3860-A

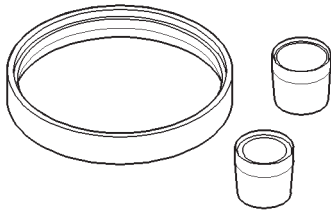
SPECIAL TOOLS (Continued)



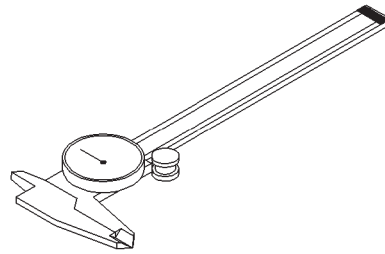
Seal Remover—C-3985-B



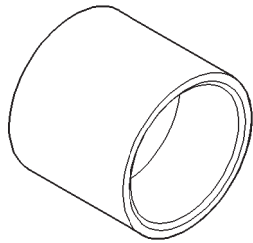
Remover/Installer—C-4470



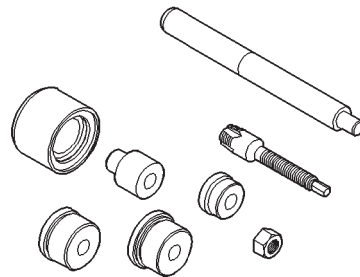
Overdrive Piston Seal Installer—8114



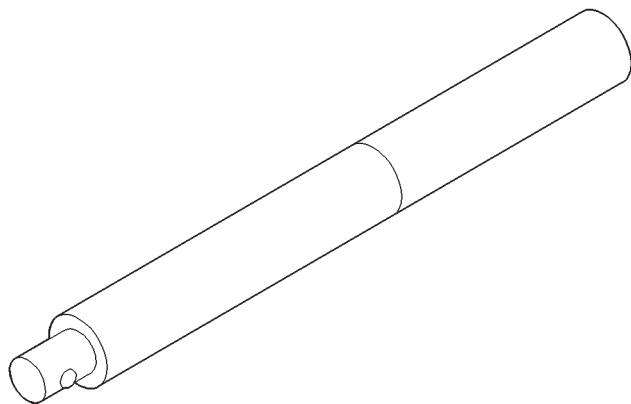
Dial Caliper—C-4962



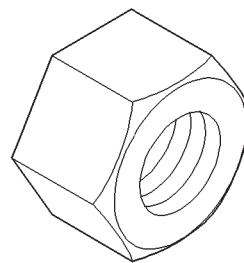
Installer—C-3995-A



Bushing Remover/Installer Set—C-3887-J

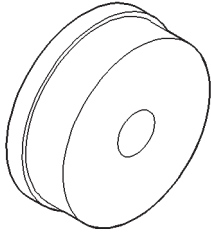


Universal Handle—C-4171

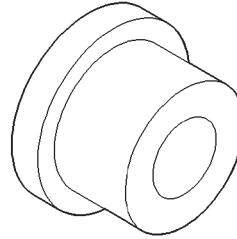


Nut, Bushing Remover—SP-1191, From kit C-3887-J

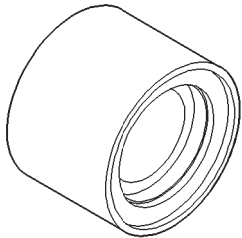
SPECIAL TOOLS (Continued)



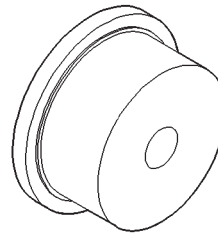
Remover, Front Clutch Bushing—SP-3629, From kit C-3887-J



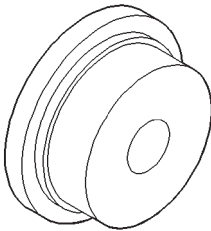
Installer, Reaction Shaft Bushing—SP-5302, From kit C-3887-J



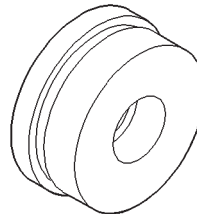
Cup, Bushing Remover—SP-3633, From kit C-3887-J



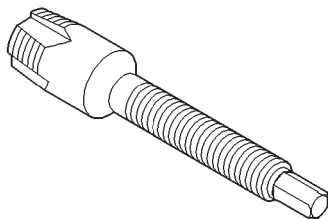
Installer, Front Clutch Bushing—SP-5511, From kit C-3887-J



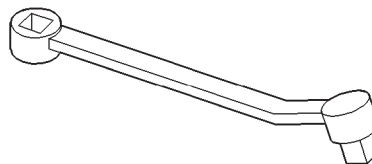
Installer, Oil Pump Bushing—SP-5118, From kit C-3887-J



Remover, Bushing—SP-3550, From kit C-3887-J



Remover, Reaction Shaft Bushing—SP-5301, From kit C-3887-J



Adapter, Band Adjuster—C-3705

NV242 TRANSFER CASE

INDEX

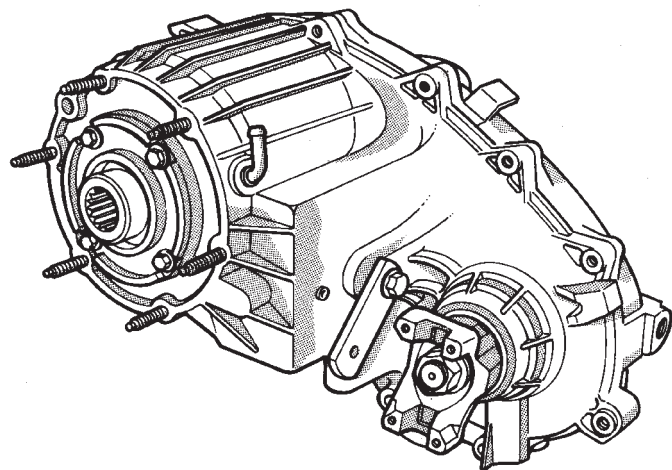
	page	page
GENERAL INFORMATION		
NV242 TRANSFER CASE	241	
RECOMMENDED LUBRICANT AND FILL LEVEL	242	
TRANSFER CASE IDENTIFICATION	241	
DIAGNOSIS AND TESTING		
NV242 DIAGNOSIS	242	
REMOVAL AND INSTALLATION		
FRONT OUTPUT SHAFT SEAL	244	
SHIFT LEVER	243	
SPEEDOMETER	243	
		243
		245
		265
		268
		268
		269

GENERAL INFORMATION

NV242 TRANSFER CASE

The NV242 is a full and part-time transfer case (Fig. 1). It provides full time 2-wheel, or 4-wheel drive operation.

A differential in the transfer case is used to control torque transfer to the front and rear axles. A low range gear provides increased low speed torque capability for off road operation. The low range provides a 2.72:1 reduction ratio.



J8921-243

Fig. 1 NV242 Transfer Case

The input gear is splined to the transmission output shaft. It drives the mainshaft through the planetary gear and range hub. The front output shaft is

operated by a drive chain that connects the shaft to a drive sprocket on the mainshaft. The drive sprocket is engaged/disengaged by the mode fork, which operates the mode sleeve and hub. The sleeve and hub are not equipped with a synchro mechanism for shifting.

The geartrain is mounted in two aluminum case halves attached with bolts. The mainshaft front and rear bearings are mounted in aluminum retainer housings bolted to the case halves.

OPERATING RANGES

NV242 operating ranges are 2WD (2-wheel drive), 4x4 part-time, 4x4 full time, and 4 Lo.

The 2WD and 4x4 full time ranges can be used at any time and on any road surface.

The 4x4 part-time and 4 Lo ranges are for off road use only. The only time these ranges can be used on hard surface roads, is when the surface is covered with snow and ice.

SHIFT MECHANISM

Operating ranges are selected with a floor mounted shift lever. The shift lever is connected to the transfer case range lever by an adjustable linkage rod. A straight line shift pattern is used. Range positions are marked on the shifter bezel cover plate, or on the shift knob.

TRANSFER CASE IDENTIFICATION

A circular ID tag is attached to the rear case of each transfer case (Fig. 2). The ID tag provides the transfer case model number, assembly number, serial number, and low range ratio.

The transfer case serial number also represents the date of build.

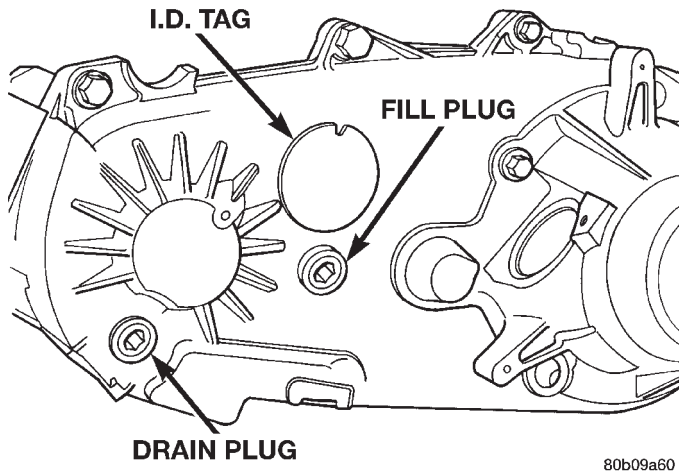
GENERAL INFORMATION (Continued)

Fig. 2 Fill/Drain Plug And I.D. Tag Locations

RECOMMENDED LUBRICANT AND FILL LEVEL

Recommended lubricant for the NV242 transfer case is Mopar® Dexron II, or ATF Plus, type 7176. Approximate lubricant fill capacity is 1.35 liters (2.85 pints).

The fill and drain plugs are both in the rear case (Fig. 2). Correct fill level is to the bottom edge of the fill plug hole. Be sure the vehicle is level to ensure an accurate fluid level check.

DIAGNOSIS AND TESTING**NV242 DIAGNOSIS****DIAGNOSIS CHART**

Condition	Possible Cause	Correction
Transfer case difficult to shift or will not shift into desired range.	1) Transfer case shift linkage binding.	1) Repair or replace linkage as necessary.
	2) Insufficient or incorrect lubricant.	3) Drain and refill transfer case with the correct type and quantity of lubricant.
	3) Internal transfer case components binding, worn, or damaged.	3) Repair or replace components as necessary.
Transfer case noisy in all drive modes.	1) Insufficient or incorrect lubricant.	1) Drain and refill transfer case with the correct type and quantity of lubricant.
Lubricant leaking from transfer case seals or vent.	1) Transfer case overfilled.	1) Drain lubricant to the correct level.
	2) Transfer case vent closed or restricted.	2) Clean or replace vent as necessary.
	3) Transfer case seals damaged or installed incorrectly.	3) Replace suspect seal.
Transfer case will not shift through 4X4 part time range (light remains on)	1) Incomplete shift due to drivetrain torque load.	1) Momentarily release the accelerator pedal to complete the shift.
	2) Incorrect tire pressure.	2) Correct tire pressure as necessary.
	3) Excessive Tire wear.	3) Correct tire condition as necessary.
	4) Excessive vehicle loading.	4) Correct as necessary.

REMOVAL AND INSTALLATION

TRANSFER CASE

REMOVAL

- (1) Shift transfer case into Neutral.
- (2) Raise vehicle.
- (3) Drain transfer case lubricant.
- (4) Mark front and rear propeller shaft yokes for alignment reference.
- (5) Support transmission with jack stand.
- (6) Remove rear crossmember, or skid plate.
- (7) Disconnect front/rear propeller shafts at transfer case.
- (8) Disconnect vehicle speed sensor wires.
- (9) Disconnect transfer case linkage rod from range lever.
- (10) Disconnect transfer case vent hose (Fig. 3) and indicator switch harness, if necessary.
- (11) Support transfer case with transmission jack.
- (12) Secure transfer case to jack with chains.
- (13) Remove nuts attaching transfer case to transmission.
- (14) Pull transfer case and jack rearward to disengage transfer case.
- (15) Remove transfer case from under vehicle.

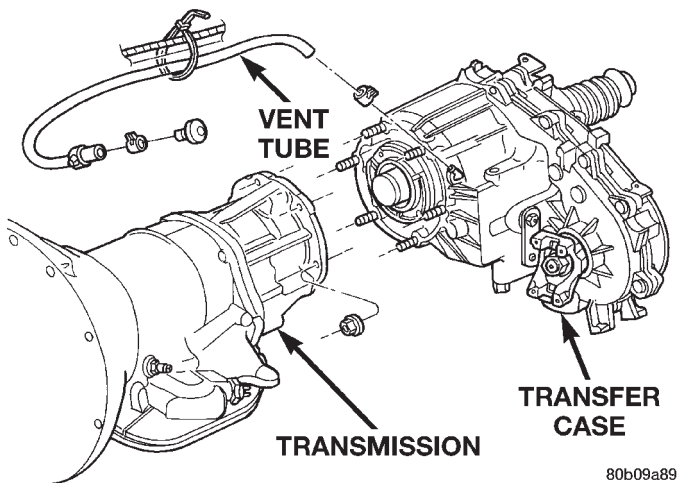


Fig. 3 Transfer Case Mounting

INSTALLATION

- (1) Mount transfer case on a transmission jack.
- (2) Secure transfer case to jack with chains.
- (3) Position transfer case under vehicle.
- (4) Align transfer case and transmission shafts and install transfer case on transmission.
- (5) Install and tighten transfer case attaching nuts to 35 N·m (26 ft. lbs.) torque (Fig. 3).
- (6) Connect vehicle speed sensor wires, and vent hose.
- (7) Connect indicator switch harness to transfer case switch, if necessary. Secure wire harness to clips on transfer case.

(8) Align and connect propeller shafts. Refer to Group 3, Differential and Driveline, for proper procedures and specifications.

(9) Fill transfer case with correct fluid. Check transmission fluid level. Correct as necessary.

(10) Install rear crossmember, or skid plate. Tighten crossmember bolts to 41 N·m (30 ft. lbs.) torque.

(11) Remove transmission jack and support stand.

(12) Connect shift rod to transfer case range lever.

(13) Adjust transfer case shift linkage.

(14) Lower vehicle and verify transfer case shift operation.

SHIFT LEVER

REMOVAL

- (1) Shift transfer case into 4L.
- (2) Raise vehicle.
- (3) Loosen adjusting trunnion locknut and slide shift rod out of trunnion (Fig. 4). If rod lacks enough travel to come out of trunnion, push trunnion out of torque shaft.
- (4) Lower vehicle.
- (5) Remove console. Refer to Group 23, Body, for proper procedures.
- (6) Remove screws attaching lever assembly to floorpan and remove assembly and shift rod (if left attached).

INSTALLATION

- (1) If shift rod was not removed from lever assembly, work rod down through floorpan opening. Then position lever assembly on floorpan and install assembly attaching screws.
- (2) Install console. Refer to Group 23, Body, for proper procedures.
- (3) Raise vehicle.
- (4) Connect trunnion to torque shaft arm. Or, slide shift rod into trunnion on range lever. Be sure shift rod slides freely in trunnion.
- (5) Verify that range lever is in 4L position. Then tighten trunnion lock bolt.
- (6) Lower vehicle and check transfer case shift operation.

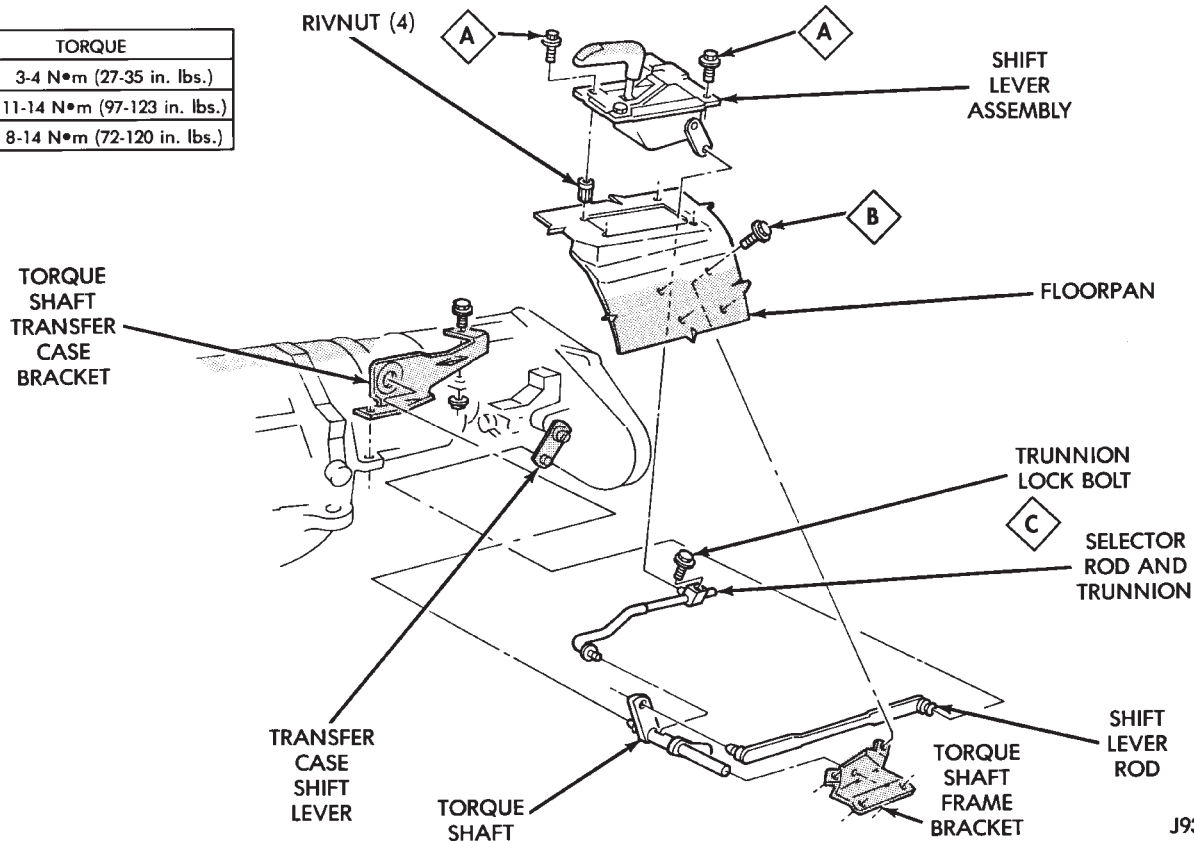
SPEEDOMETER

REMOVAL

- (1) Raise vehicle.
- (2) Disconnect wires from vehicle speed sensor.
- (3) Remove adapter clamp and screw (Fig. 5).
- (4) Remove speed sensor and speedometer adapter as an assembly.
- (5) Remove speed sensor retaining screw and remove sensor from adapter.

REMOVAL AND INSTALLATION (Continued)

TORQUE	
A	3-4 N•m (27-35 in. lbs.)
B	11-14 N•m (97-123 in. lbs.)
C	8-14 N•m (72-120 in. lbs.)



J9321-185

Fig. 4 Shift Linkage

(6) Remove speedometer pinion from adapter. Replace pinion if chipped, cracked, or worn.

(7) Inspect sensor and adapter O-rings (Fig. 5). Remove and discard O-rings if worn or damaged.

(8) Inspect terminal pins in speed sensor. Clean pins with Mopar® electrical spray cleaner if dirty or oxidized. Replace sensor if faulty, or if pins are loose, severely corroded, or damaged.

INSTALLATION AND INDEXING

(1) Thoroughly clean adapter flange and adapter mounting surface in housing. Surfaces must be clean for proper adapter alignment and speedometer operation.

(2) Install new O-rings on speed sensor and speedometer adapter (Fig. 5), if necessary.

(3) Lubricate sensor and adapter O-rings with transmission fluid.

(4) Install vehicle speed sensor in speedometer adapter. Tighten sensor attaching screw to 2-3 N•m (15-27 in. lbs.) torque.

(5) Install speedometer pinion in adapter.

(6) Count number of teeth on speedometer pinion. Do this before installing assembly in housing. Then lubricate pinion teeth with transmission fluid.

(7) Note index numbers on adapter body (Fig. 6). These numbers will correspond to number of teeth on pinion.

(8) Install speedometer assembly in housing.

(9) Rotate adapter until required range numbers are at 6 o'clock position. Be sure range index numbers correspond to number of teeth on pinion gear.

(10) Install speedometer adapter clamp and retaining screw. Tighten clamp screw to 10-12 N•m (90-110 in. lbs.) torque.

(11) Connect wires to vehicle speed sensor.

(12) Lower vehicle and top off transmission fluid level if necessary.

FRONT OUTPUT SHAFT SEAL**REMOVAL**

(1) Raise vehicle.

(2) Remove front propeller shaft. Refer to Group 3, Differential and Driveline, for proper procedure.

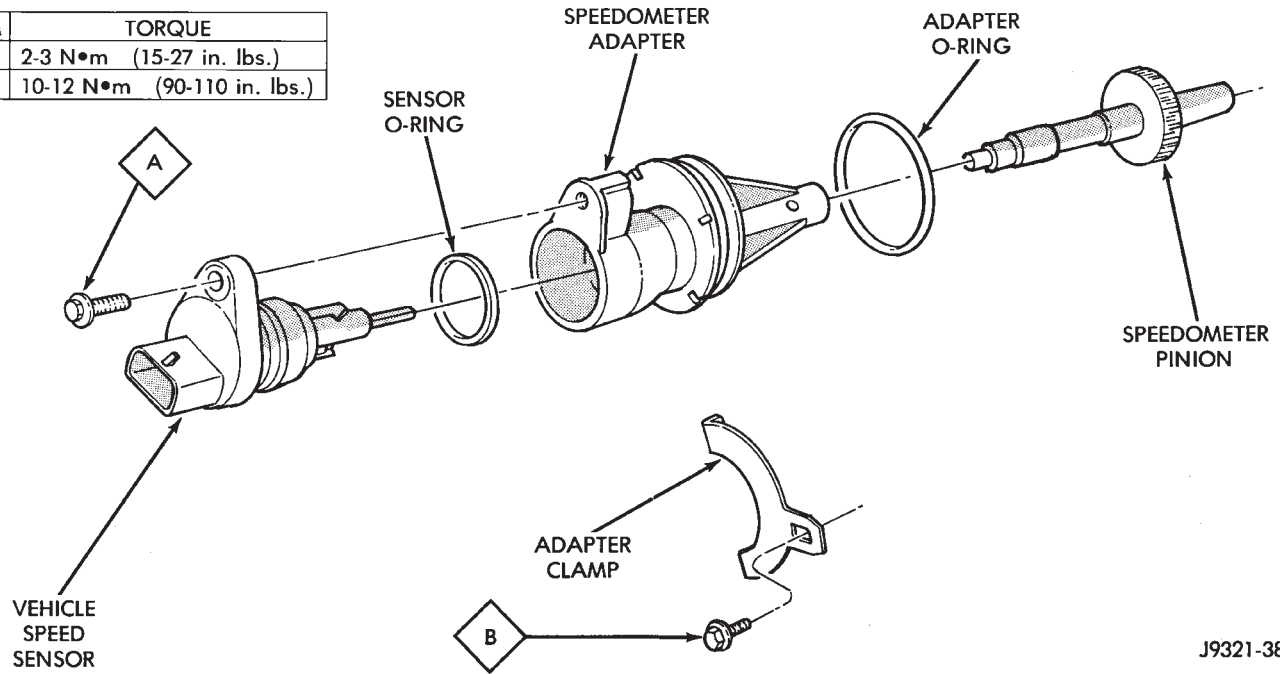
(3) Remove front output shaft yoke.

(4) Remove seal from front case with pry tool (Fig.

7).

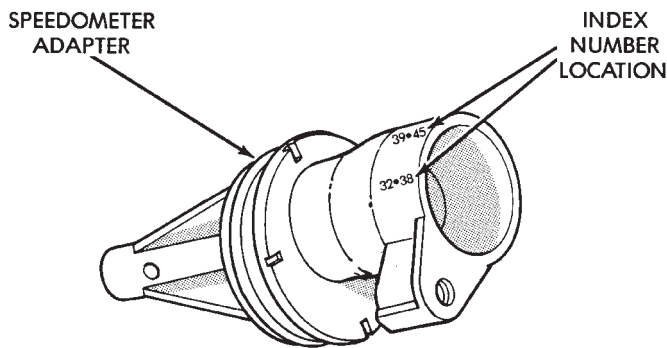
REMOVAL AND INSTALLATION (Continued)

ITEM	TORQUE
A	2-3 N•m (15-27 in. lbs.)
B	10-12 N•m (90-110 in. lbs.)



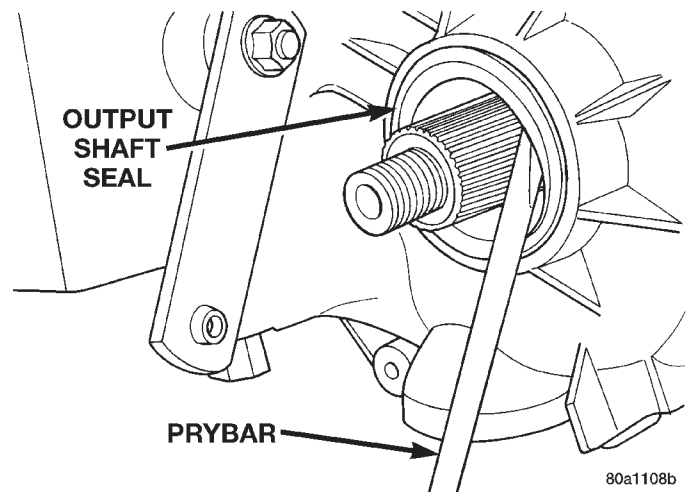
J9321-385

Fig. 5 Speedometer Components



J9321-386

Fig. 6 Location Of Index Numbers On Speedometer Adapter



80a1108b

**Fig. 7 Remove Front Output Shaft Seal
DISASSEMBLY AND ASSEMBLY**

INSTALLATION

- (1) Install new front output seal in front case with Installer Tool 6952-A as follows:
 - (a) Place new seal on tool. Garter spring on seal goes toward interior of case.
 - (b) Start seal in bore with light taps from hammer (Fig. 8). Once seal is started, continue tapping seal into bore until installer tool seats against case.

NV242 TRANSFER CASE

DISASSEMBLY

REAR RETAINER REMOVAL

- (1) Remove output shaft boot. Spread band clamp that secures boot on slinger with a suitable awl. Then slide boot off shaft (Fig. 9).

DISASSEMBLY AND ASSEMBLY (Continued)

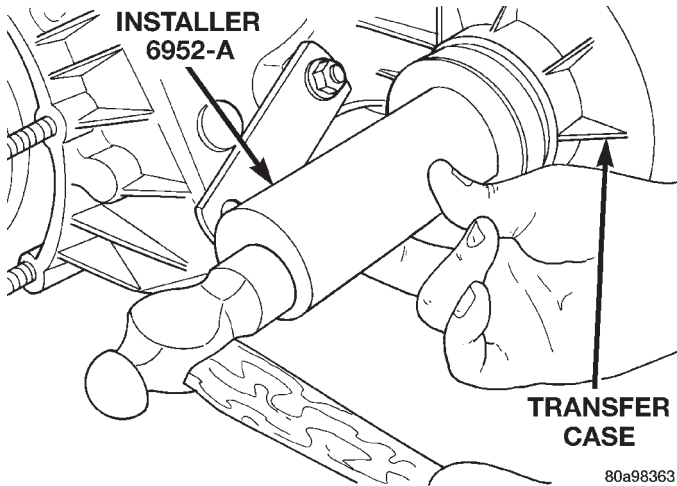


Fig. 8 Front Output Seal Installation

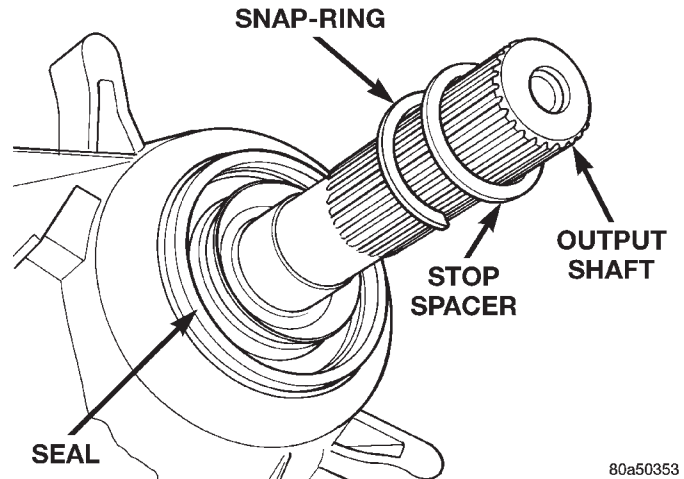


Fig. 11 Slinger Stop Spacer and Snap-ring

(4) Remove rear seal from retainer (Fig. 12). Use pry tool, or collapse seal with punch to remove it.

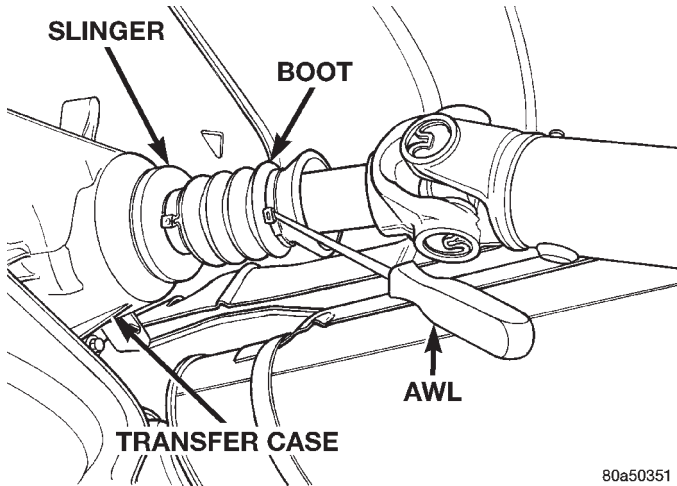


Fig. 9 Output Boot—Typical

(2) Using puller MD-998056-A, remove rear slinger (Fig. 10).

(3) Remove slinger stop spacer and snap-ring from output shaft (Fig. 11).

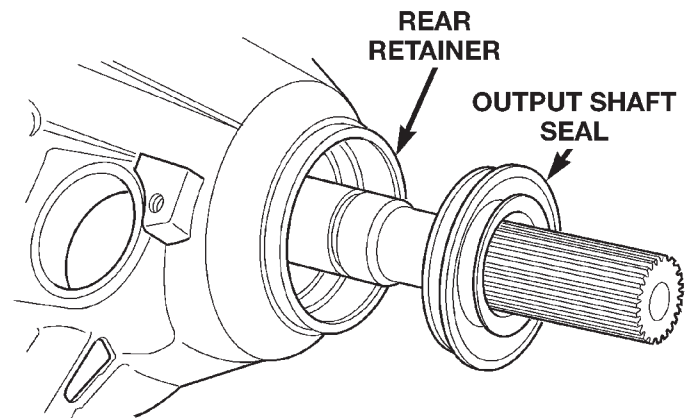


Fig. 12 Rear Seal Removal

(5) Remove rear output bearing I.D. retaining ring (Fig. 13).

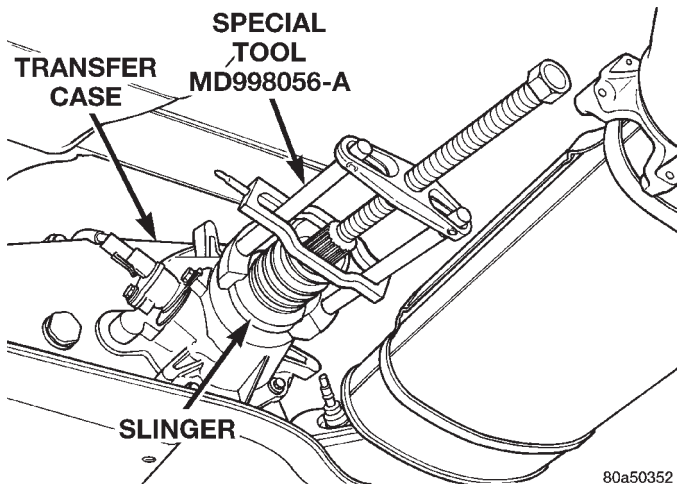


Fig. 10 Rear Slinger Removal

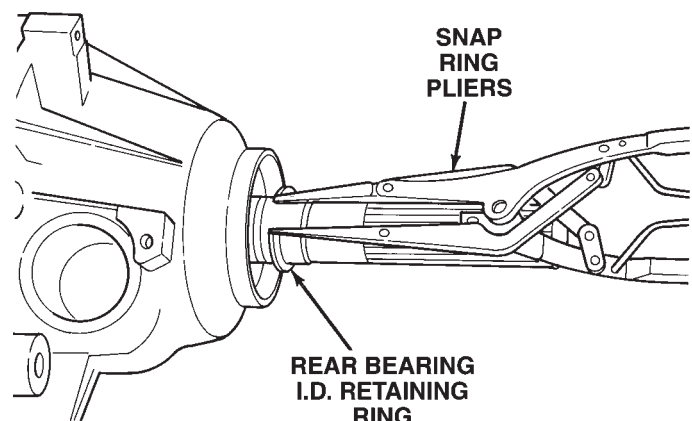


Fig. 13 Rear Bearing I.D. Retaining Ring Removal

DISASSEMBLY AND ASSEMBLY (Continued)

- (6) Remove speedometer adapter.
- (7) Remove rear retainer bolts.
- (8) Remove rear retainer. Tap retainer with mallet and pry upward to break sealer bead. Then slide retainer off case and output shaft (Fig. 14).

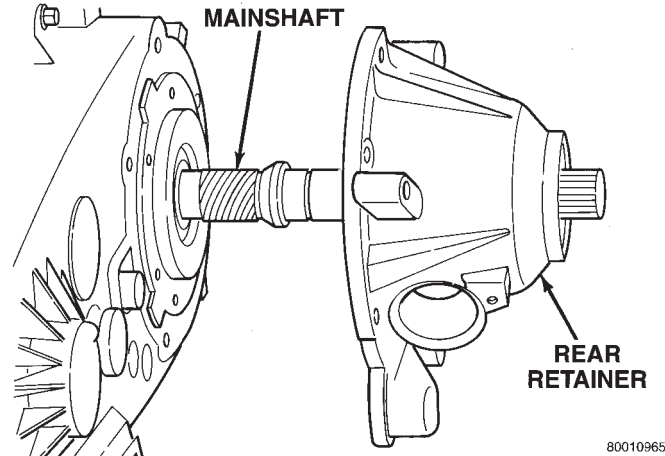


Fig. 14 Rear Retainer Removal

- (9) Remove rear bearing O.D. retaining ring with snap ring pliers. Then tilt pump and slide it off output shaft (Fig. 15)

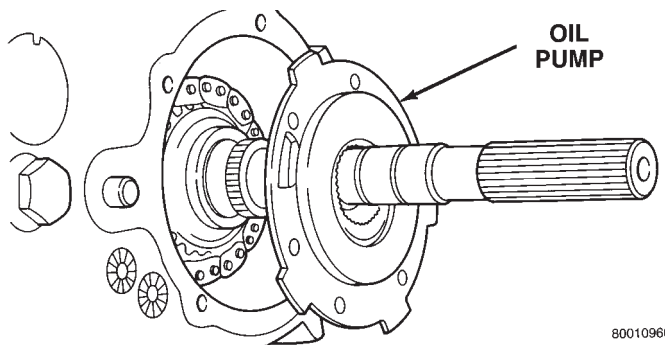


Fig. 15 Oil Pump Removal

- (10) Remove pickup tube O-ring from pump (Fig. 16) but do not disassemble pump; it is not a repairable part.
- (11) Remove seal from oil pump with pry tool.
- (12) Remove bolts attaching rear case to front case (Fig. 17). Note position of the two black finish bolts at each end of the case. These bolts go through the case dowels and require a washer under the bolt head.
- (13) Remove rear case from front case (Fig. 18). Insert screwdrivers into slots cast into each end of case. Then pry upward to break sealer bead and remove rear case.

CAUTION: Do not pry on the sealing surface of either case half as the surfaces will become damaged.

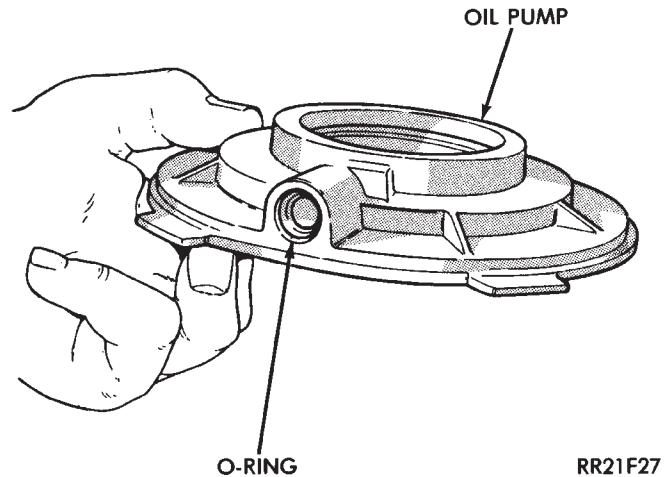


Fig. 16 Pickup Tube O-Ring Location

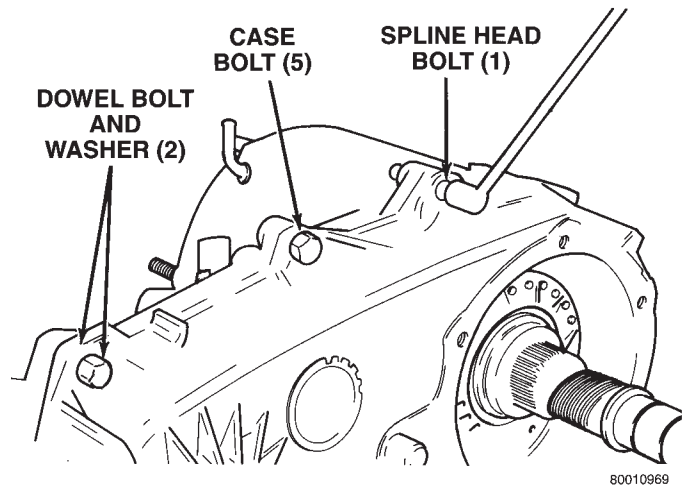


Fig. 17 Spline And Dowel Bolt Locations

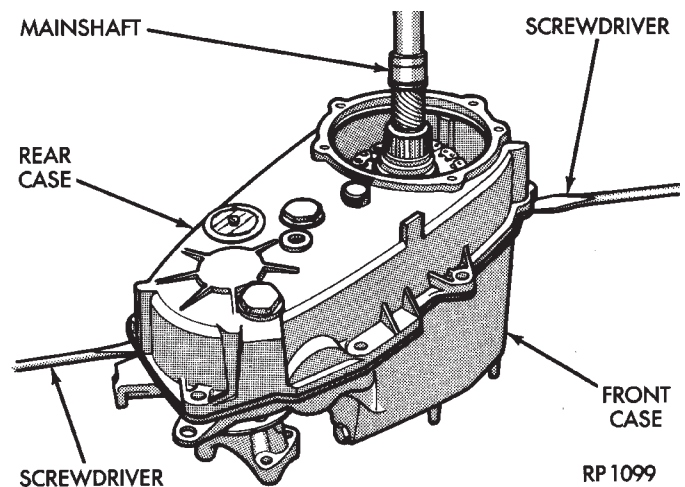
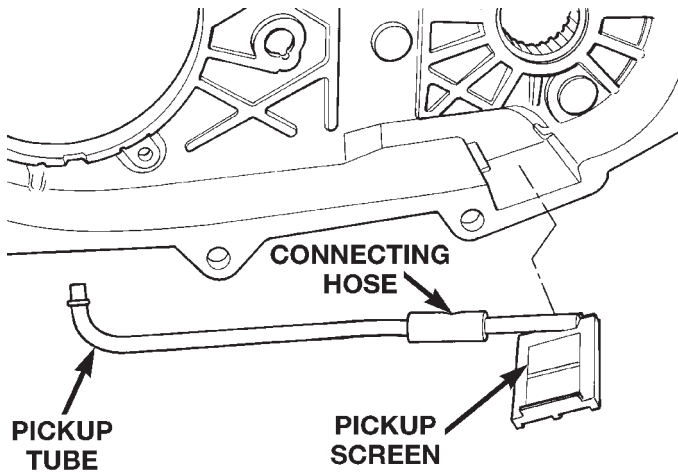


Fig. 18 Loosening/Removing Rear case

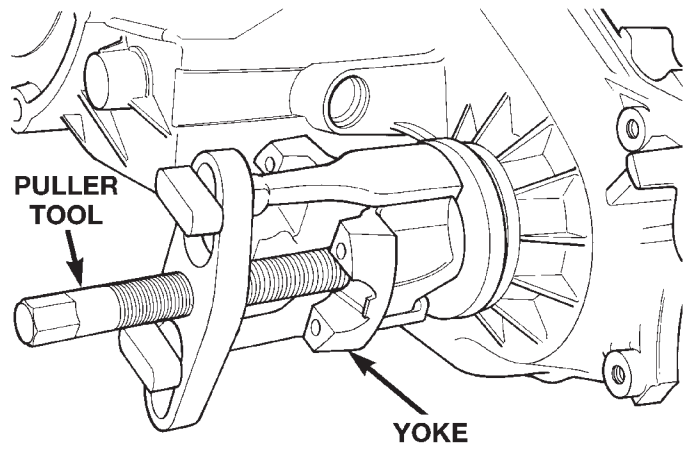
- (14) Remove oil pickup tube and screen from rear case (Fig. 19).

DISASSEMBLY AND ASSEMBLY (Continued)



80010979

Fig. 19 Oil Pickup Screen, Hose And Tube Removal

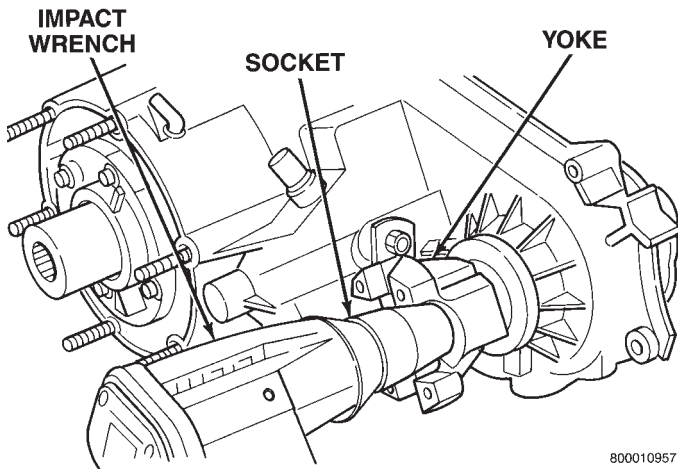


80010977

Fig. 21 Yoke Removal

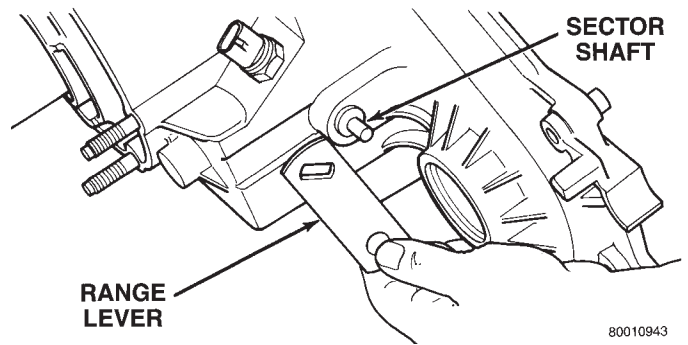
YOKE AND RANGE LEVER REMOVAL

- (1) Remove front yoke nut:
 - (a) Move range lever to 4L position.
 - (b) Remove nut with socket and impact wrench (Fig. 20).



800010957

Fig. 20 Yoke Nut Removal



80010943

Fig. 22 Range Lever Removal

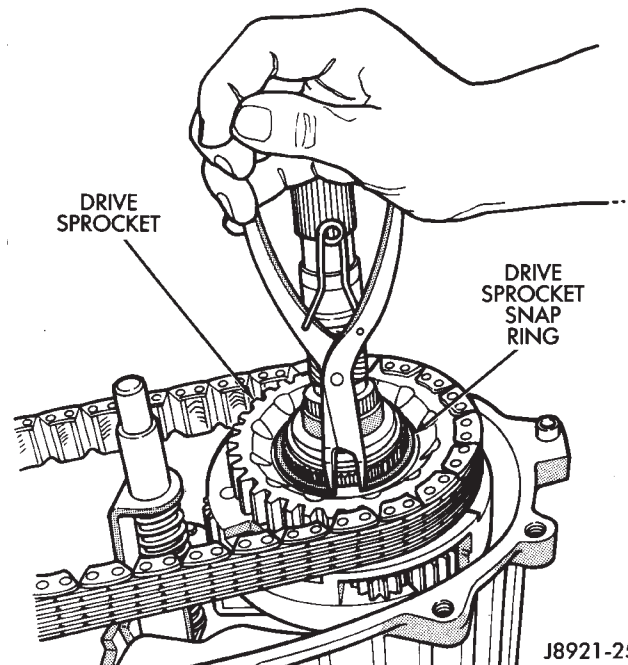
- (2) Remove yoke. If yoke is difficult to remove by hand, remove it with bearing splitter, or with standard two jaw puller (Fig. 21). Be sure puller tool is positioned on yoke and not on slinger as slinger will be damaged.

- (3) Remove seal washer from front output shaft. Discard washer as it should not be reused.

- (4) Remove nut and washer that attach range lever to sector shaft. Then move sector to neutral position and remove range lever from shaft (Fig. 22).

FRONT OUTPUT SHAFT AND DRIVE CHAIN REMOVAL

- (1) Remove drive sprocket snap-ring (Fig. 23).
- (2) Remove drive sprocket and chain (Fig. 24).
- (3) Remove front output shaft (Fig. 25).



J8921-251

Fig. 23 Drive Sprocket Snap-Ring Removal

DISASSEMBLY AND ASSEMBLY (Continued)

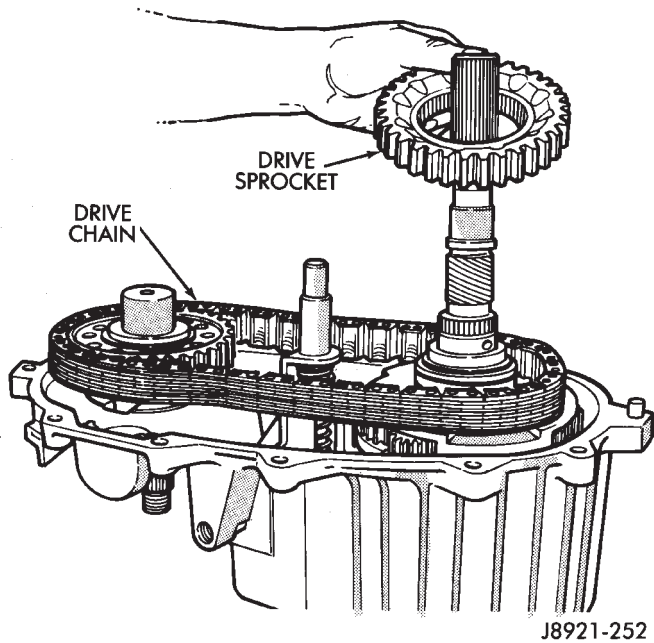


Fig. 24 Drive Sprocket And Chain Removal

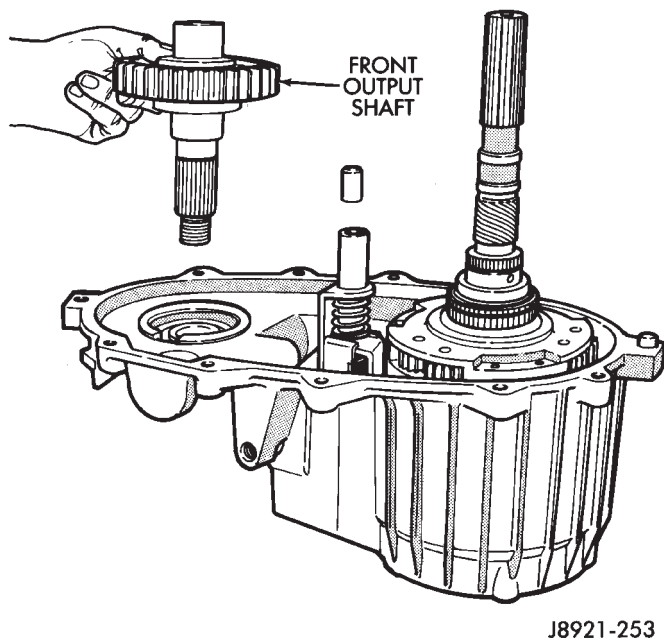


Fig. 25 Removing Front Output Shaft

SHIFT FORKS AND MAINSHAFT REMOVAL AND DISASSEMBLY

- (1) Remove shift detent plug, spring and pin (Fig. 26).
- (2) Remove seal plug from low range fork lockpin access hole. Then move shift sector to align low range fork lockpin with access hole.
- (3) Remove range fork lockpin with size number one easy-out tool as follows:
 - (a) Insert easy-out tool through access hole in side of transfer case and into lock-pin.

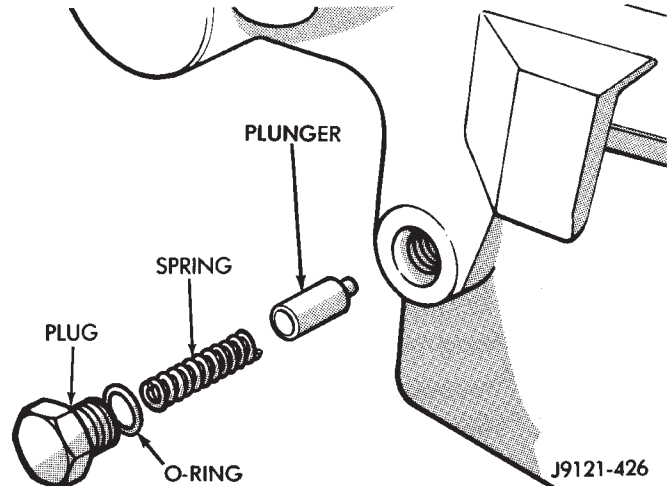


Fig. 26 Detent Component Removal

- (b) Tap easy-out tool into lock-pin with hammer until tool is securely engaged into the lock-pin.
- (c) Install a t-handle, such as from a tap and die set, onto the easy-out tool.
- (d) Securely tighten the t-handle onto the tool.
- (e) In one motion, pull upward and turn the t-handle counter-clockwise to remove the lock-pin.
- (4) Remove shift rail by pulling it straight up and out of fork (Fig. 27).
- (5) Remove mode fork and mainshaft as assembly (Fig. 28).
- (6) Remove mode shift sleeve and mode fork assembly from mainshaft (Fig. 29). Note position of mode sleeve in fork and remove sleeve.

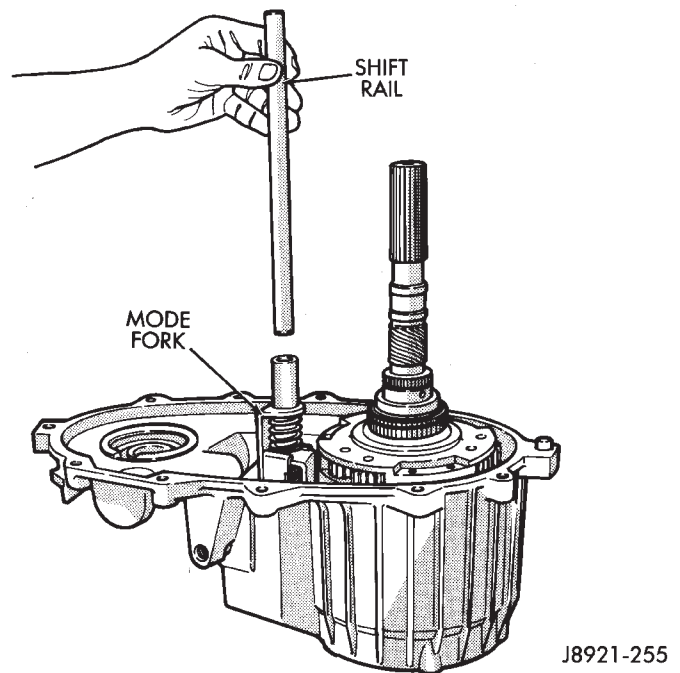


Fig. 27 Shift Rail Removal

DISASSEMBLY AND ASSEMBLY (Continued)

- (7) Remove intermediate clutch shaft snap-ring (Fig. 30).
- (8) Remove clutch shaft thrust ring (Fig. 31).
- (9) Remove intermediate clutch shaft (Fig. 32).

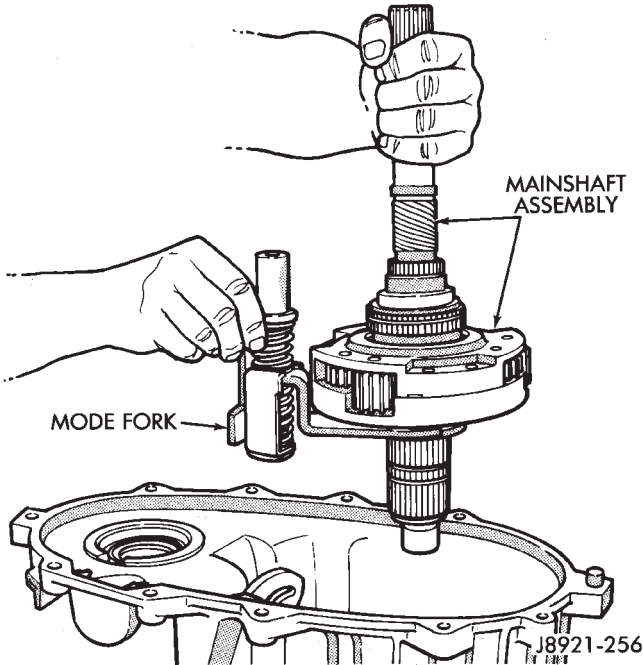


Fig. 28 Mode Fork And Mainshaft Removal

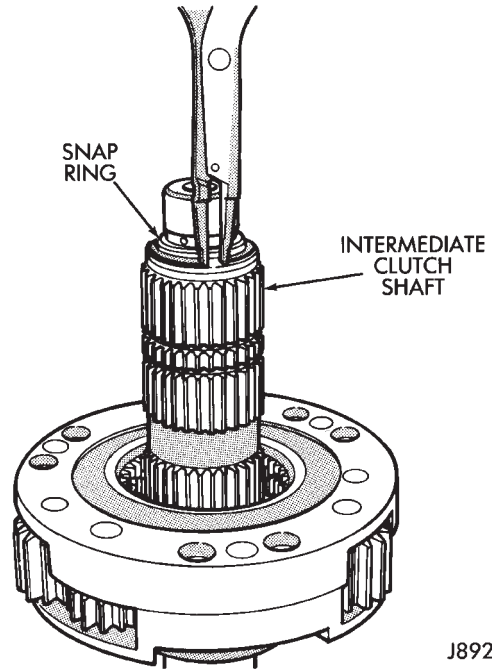


Fig. 30 Intermediate Clutch Shaft Snap-Ring Removal

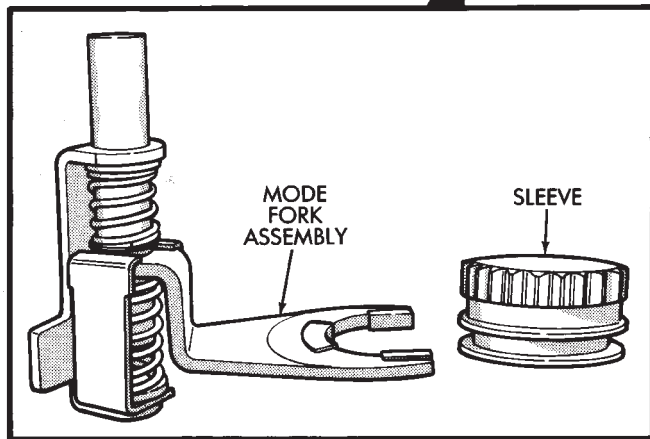
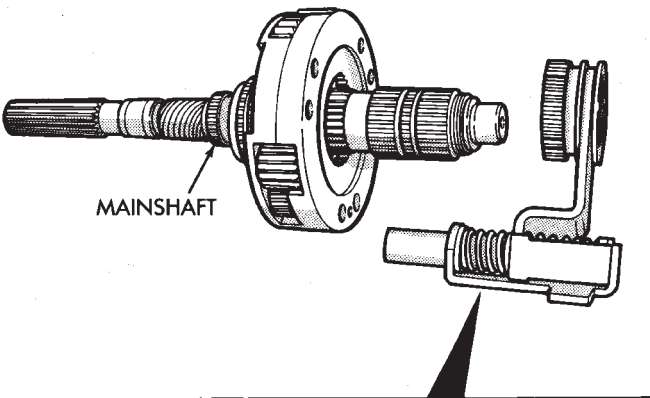


Fig. 29 Mode Fork And Sleeve Removal

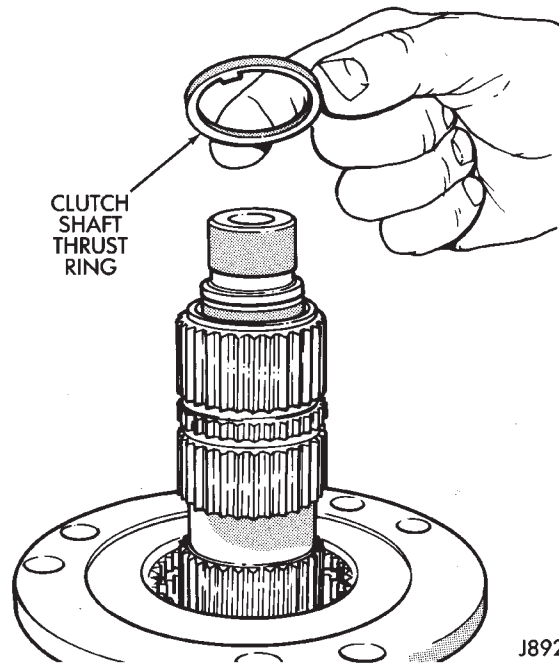
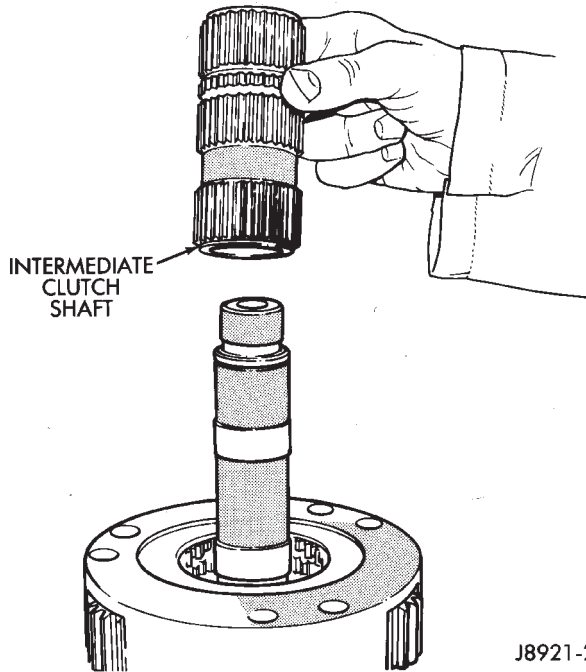
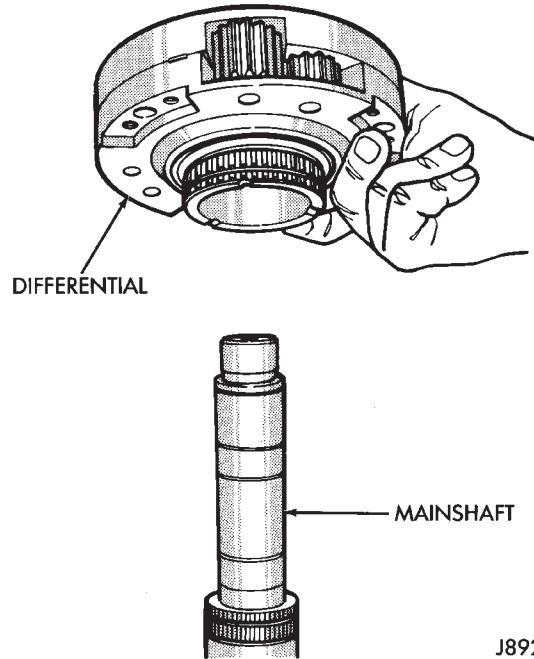


Fig. 31 Clutch Shaft Thrust Ring Removal

DISASSEMBLY AND ASSEMBLY (Continued)



J8921-260



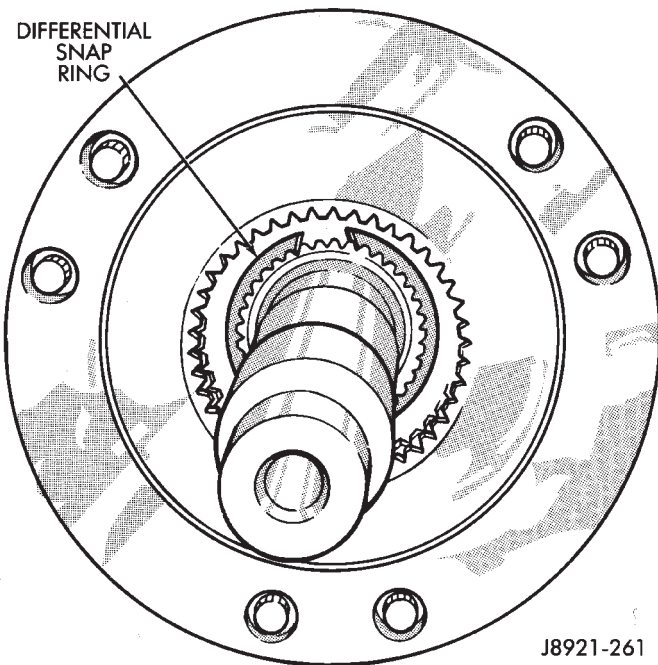
J8921-262

Fig. 32 Intermediate Clutch Shaft Removal

- (10) Remove differential snap-ring (Fig. 33).
- (11) Remove differential (Fig. 34).
- (12) Remove differential needle bearings and both needle bearing thrust washers from mainshaft.

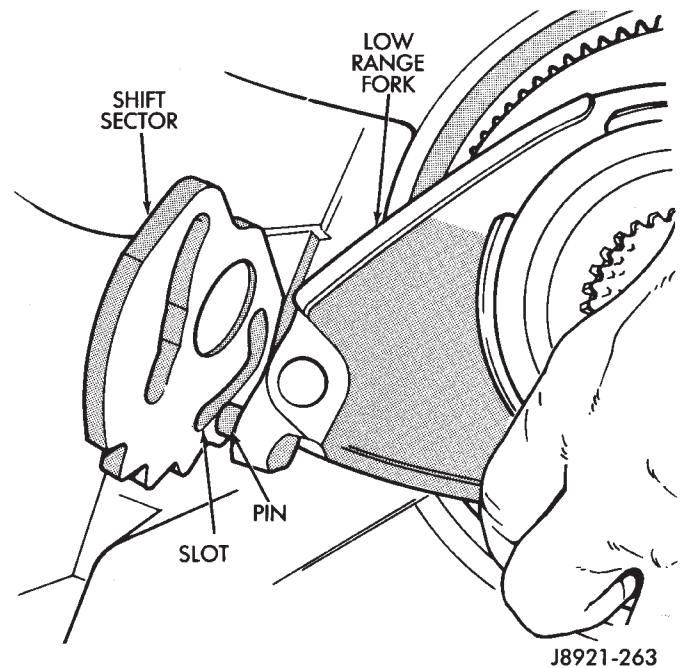
Fig. 34 Differential Removal

- (13) Slide low range fork pin out of shift sector slot (Fig. 35).
- (14) Remove low range fork and hub (Fig. 36).
- (15) Remove shift sector (Fig. 37).



J8921-261

Fig. 33 Differential Snap-Ring Removal



J8921-263

Fig. 35 Disengaging Low Range Fork

DISASSEMBLY AND ASSEMBLY (Continued)

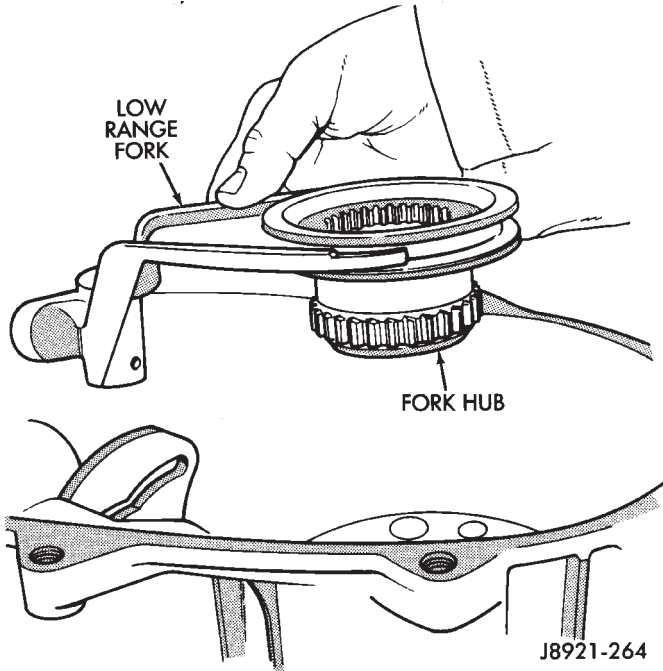


Fig. 36 Low Range Fork And Hub Removal

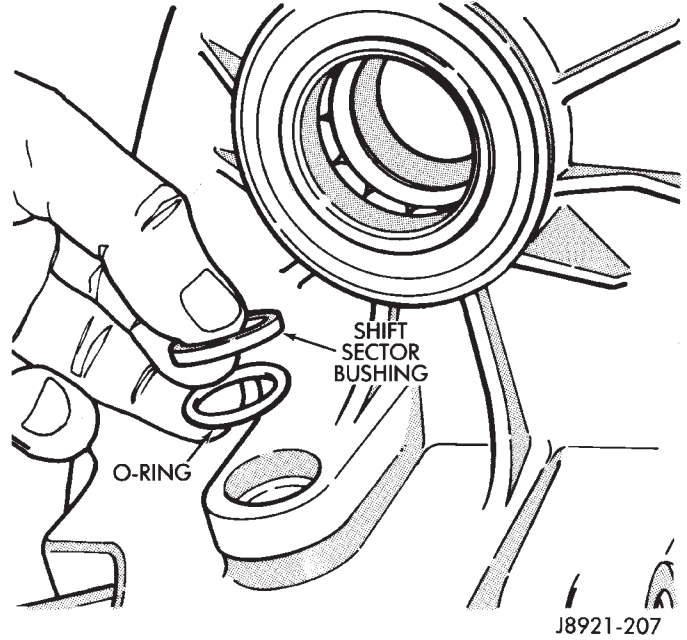


Fig. 38 Sector Bushing And O-Ring Removal

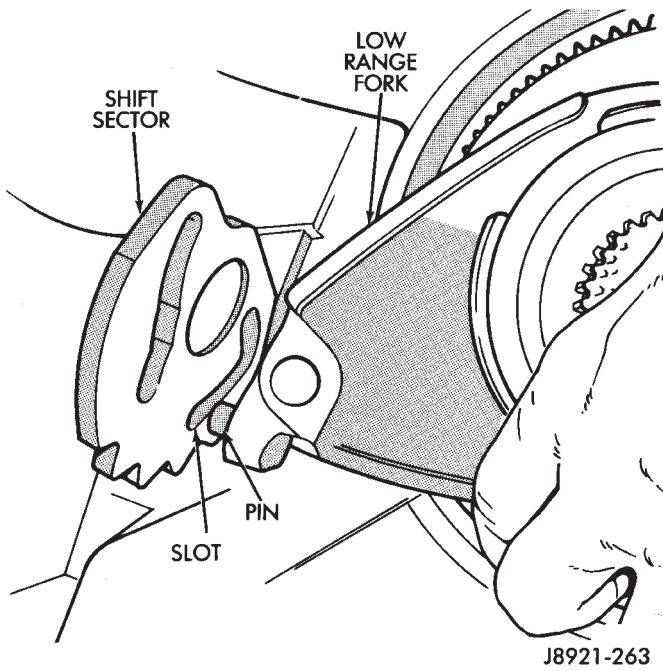


Fig. 37 Shift Sector Position

(16) Remove shift sector bushing and O-ring (Fig. 38).

INPUT GEAR/LOW RANGE ASSEMBLY REMOVAL AND DISASSEMBLY

- (1) Remove front bearing retainer bolts.
- (2) Remove front bearing retainer. Carefully pry retainer loose with screwdriver (Fig. 39). Position screwdriver in slots cast into retainer.
- (3) Remove input gear snap-ring (Fig. 40).

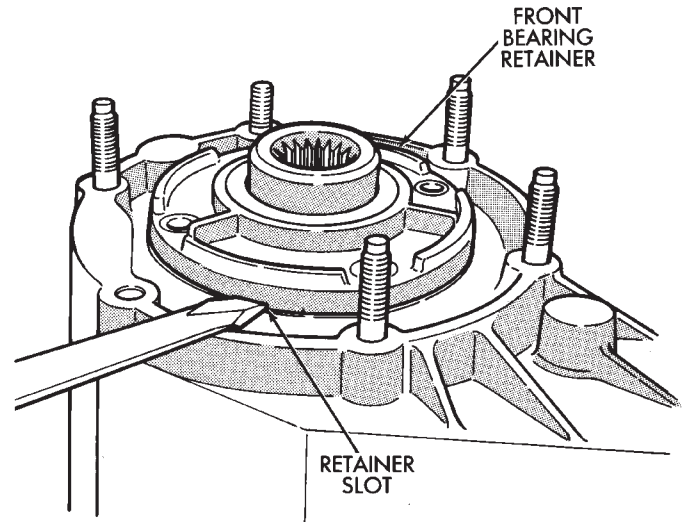
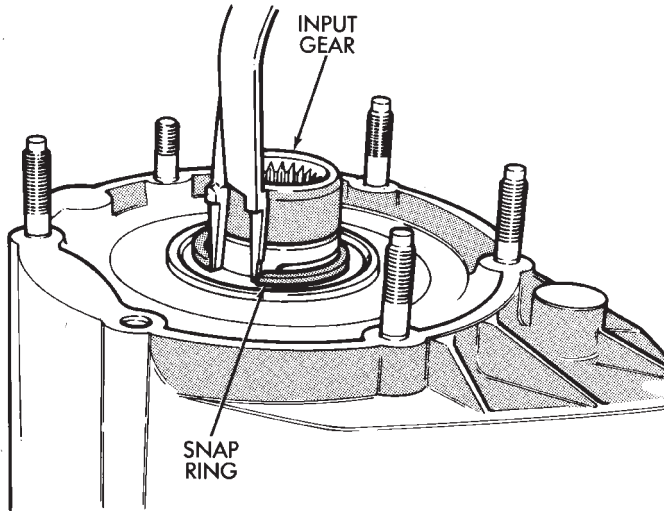


Fig. 39 Front Bearing Retainer Removal

J8921-266

DISASSEMBLY AND ASSEMBLY (Continued)



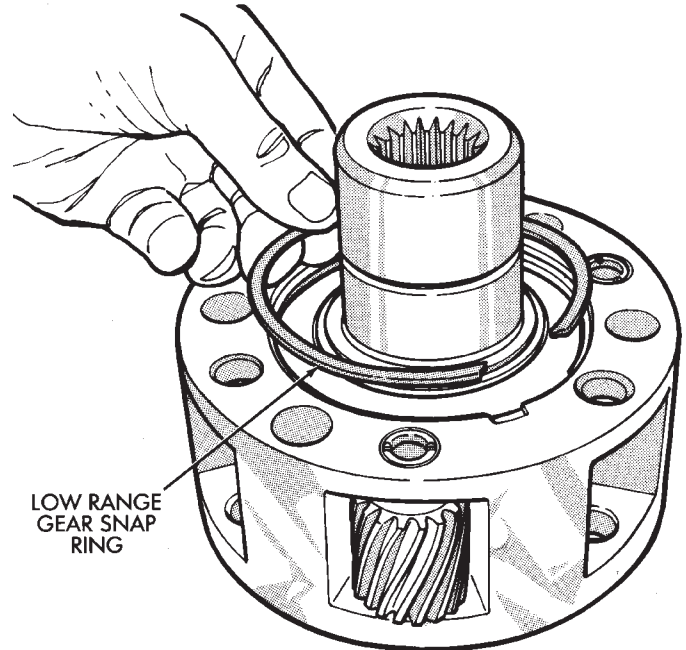
J8921-267

Fig. 40 Input Gear Snap-Ring Removal

(4) Remove input/low range gear assembly from bearing with Tool Handle C-4171 and Tool 7829A (Fig. 41).

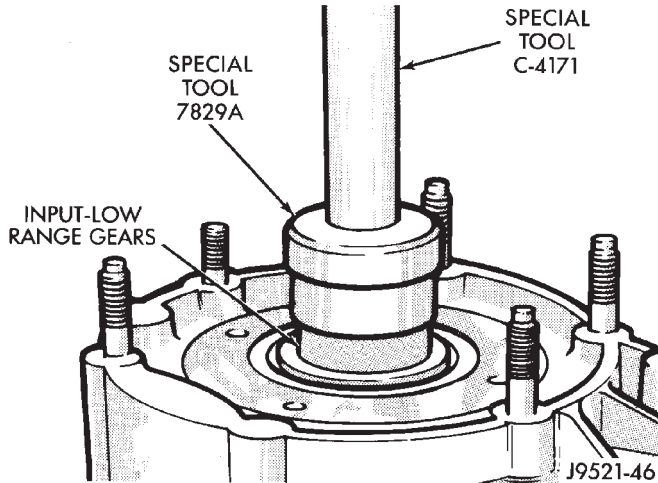
(5) Remove low range gear snap-ring (Fig. 42).

(6) Remove input gear retainer, thrust washers and input gear from low range gear (Fig. 43).



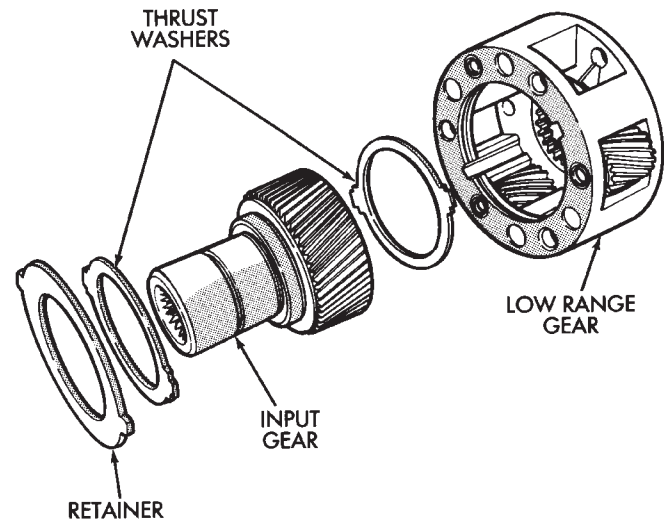
J8921-269

Fig. 42 Low Range Gear Snap-Ring Removal/Installation



J9521-46

Fig. 41 Input And Low Range Gear Assembly Removal



J8921-214

Fig. 43 Low Range Gear Disassembly

(7) Inspect low range annulus gear (Fig. 44). **Gear is not a serviceable component. If damaged, replace gear and front case as assembly.**

(8) Remove oil seals from following components:

- front bearing retainer.
- rear retainer.
- oil pump.
- case halves.

DISASSEMBLY AND ASSEMBLY (Continued)

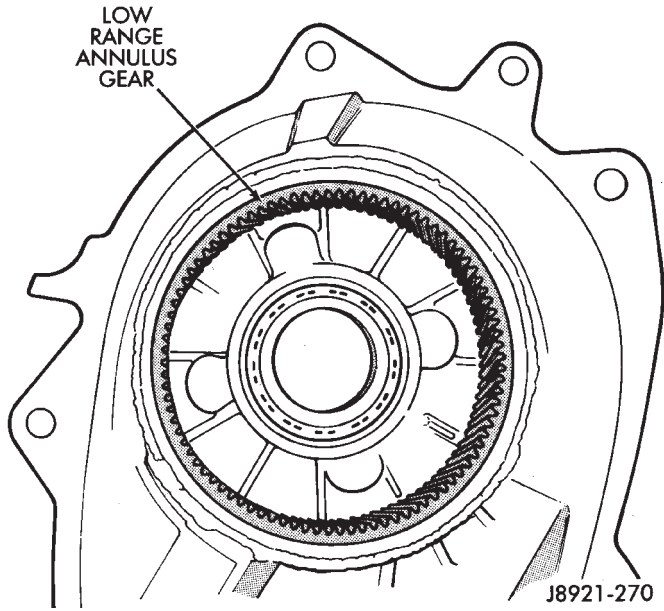


Fig. 44 Inspecting Low Range Annulus Gear

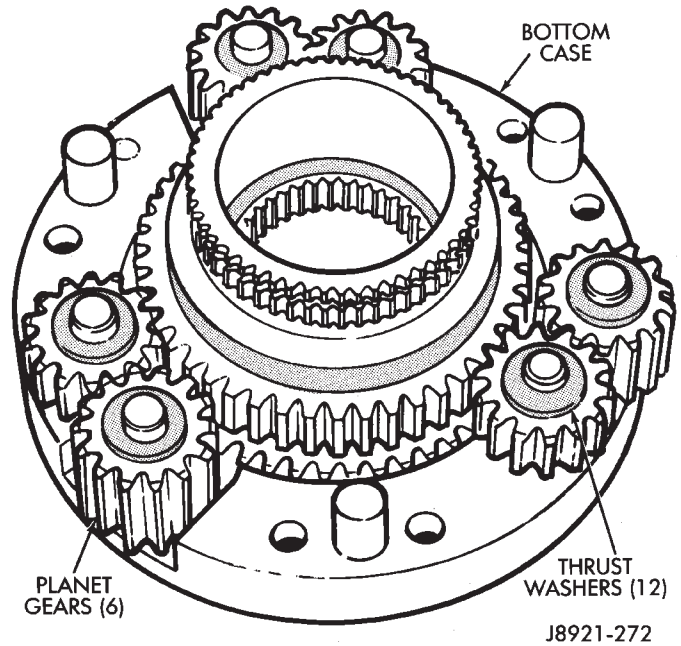


Fig. 46 Planet Gears And Thrust Washer Removal

DIFFERENTIAL DISASSEMBLY

- (1) Mark differential case halves for reference.
- (2) Remove differential case bolts.
- (3) Invert differential on workbench.
- (4) Separate top case from bottom case. Use slots in case halves to pry them apart (Fig. 45).
- (5) Remove thrust washers and planet gears from case pins (Fig. 46).
- (6) Remove mainshaft and sprocket gears from bottom case (Fig. 47). Note gear position for reference before separating them.

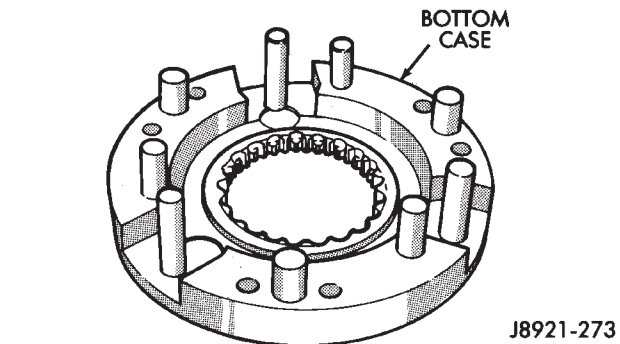
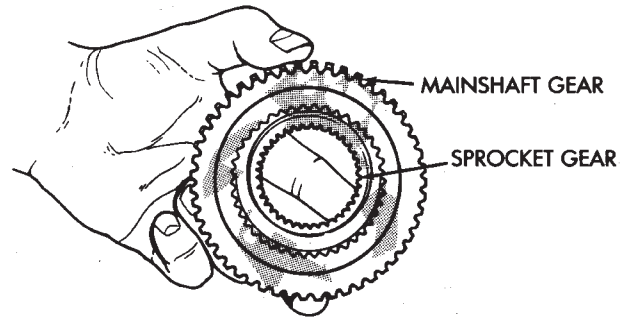


Fig. 47 Mainshaft And Sprocket Gear Removal

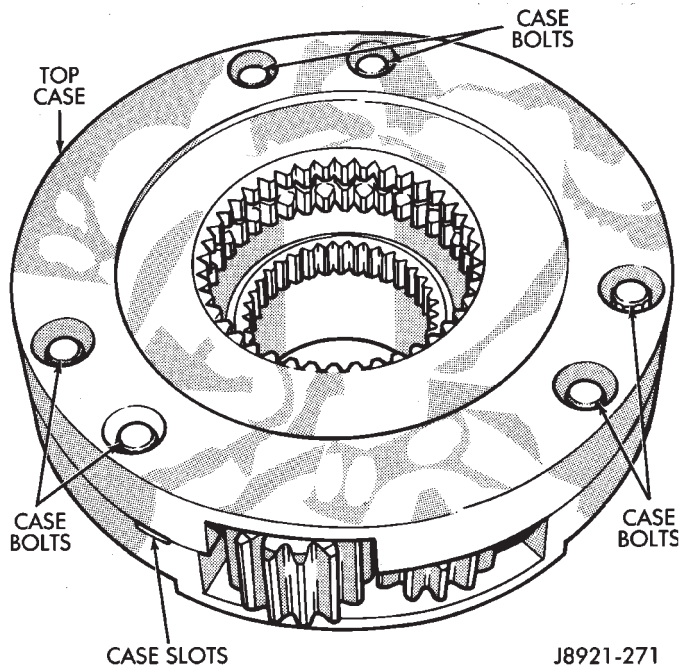


Fig. 45 Separating Differential Case Halves

ASSEMBLY

Lubricate transfer case components with automatic transmission fluid or petroleum jelly (where indicated) during assembly.

CAUTION: The bearing bores in various transfer case components contain oil feed holes. Make sure replacement bearings do not block the holes.

DISASSEMBLY AND ASSEMBLY (Continued)

BEARING AND SEAL INSTALLATION

(1) Remove snap-ring that retains front output shaft front bearing in case (Fig. 48). Then remove bearing. Use hammer handle, or hammer and brass punch to tap bearing out of case.

(2) Install new front output shaft front bearing with Tool Handle C-4171 and Installer 8033A with the tapered cone upward (Fig. 49).

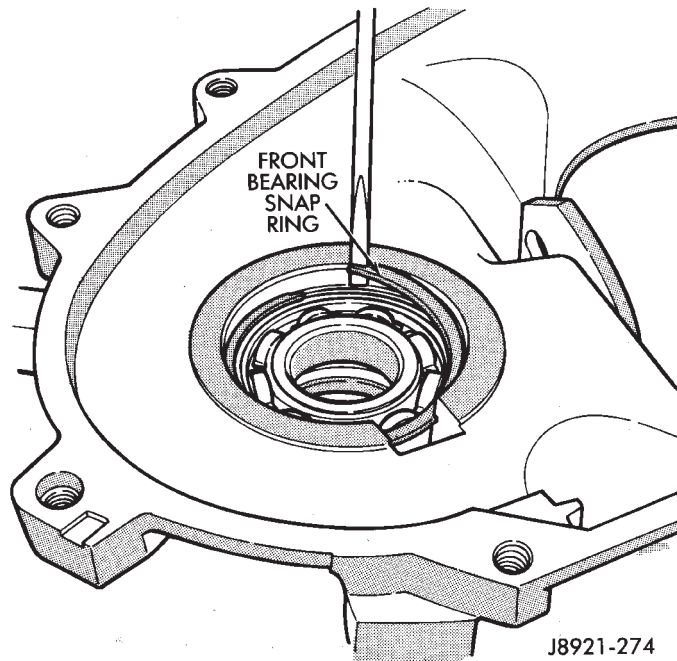


Fig. 48 Front Output Shaft Front Bearing Snap-Ring Removal

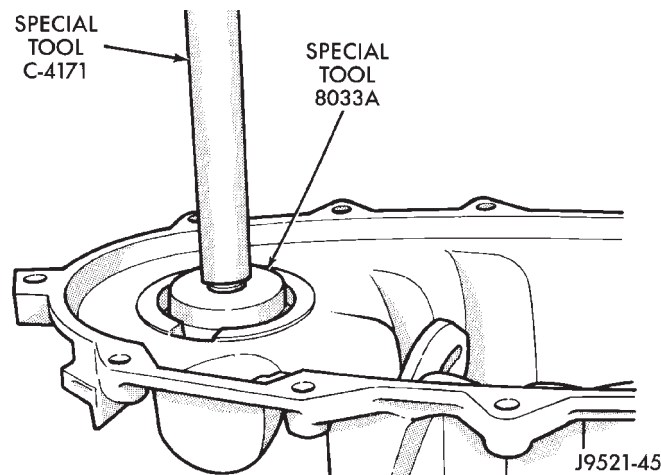


Fig. 49 Front Output Shaft Front Bearing Installation

- (3) Install front bearing snap-ring (Fig. 48).
- (4) Remove front output shaft seal using an appropriate pry tool (Fig. 50) or slide-hammer mounted screw.
- (5) Install new front output shaft oil seal with Installer 6952-A (Fig. 51).

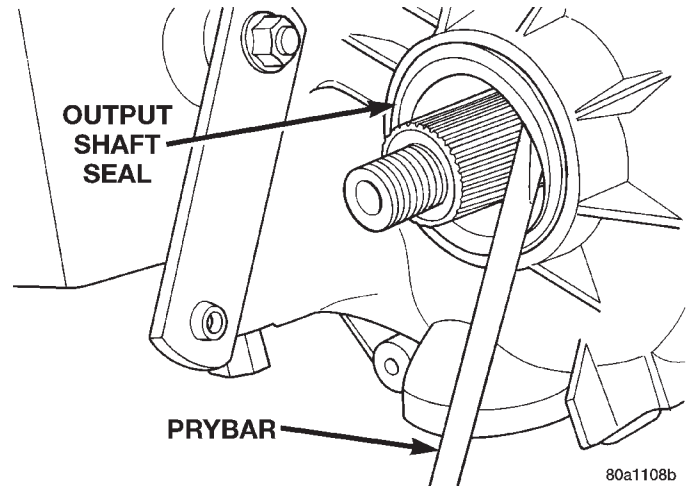


Fig. 50 Remove Front Output Shaft Seal

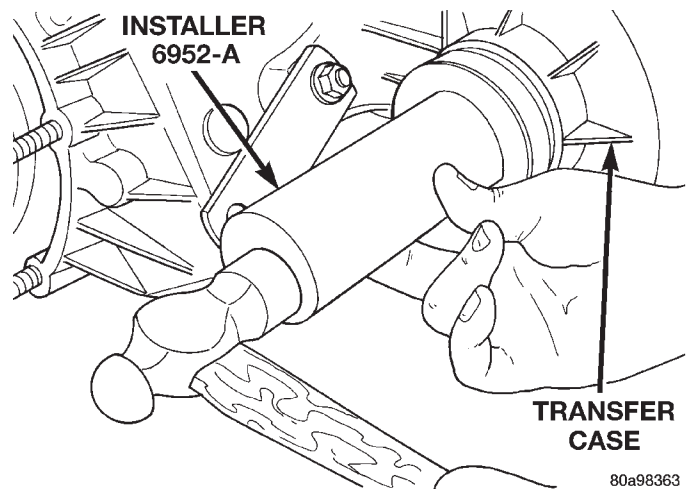


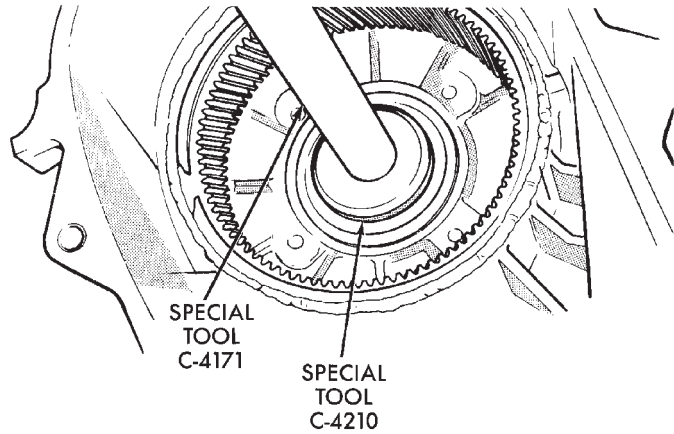
Fig. 51 Install Front Output Shaft Seal

DISASSEMBLY AND ASSEMBLY (Continued)

(6) Remove input gear bearing with Tool Handle C-4171 and Remover C-4210 (Fig. 52).

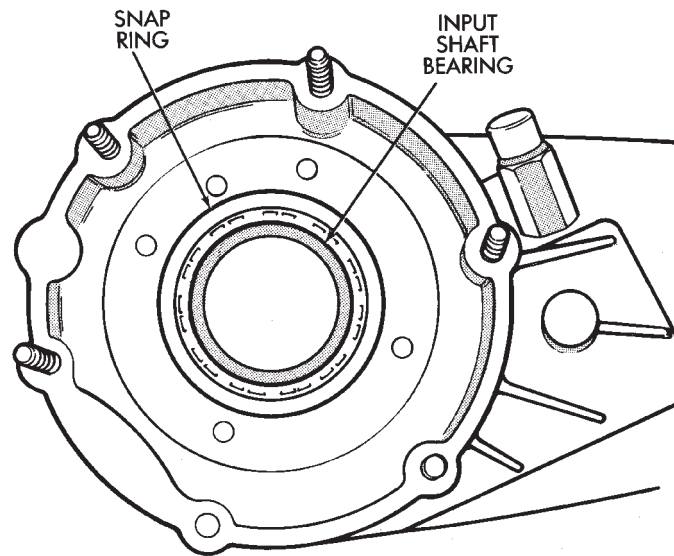
(7) Install snap-ring on new input gear bearing.

(8) Install new input gear bearing with Tool Handle C-4171 and Remover C-4210. Install bearing far enough to seat snap-ring against case (Fig. 53).



J9521-43

Fig. 52 Input Gear Bearing Removal

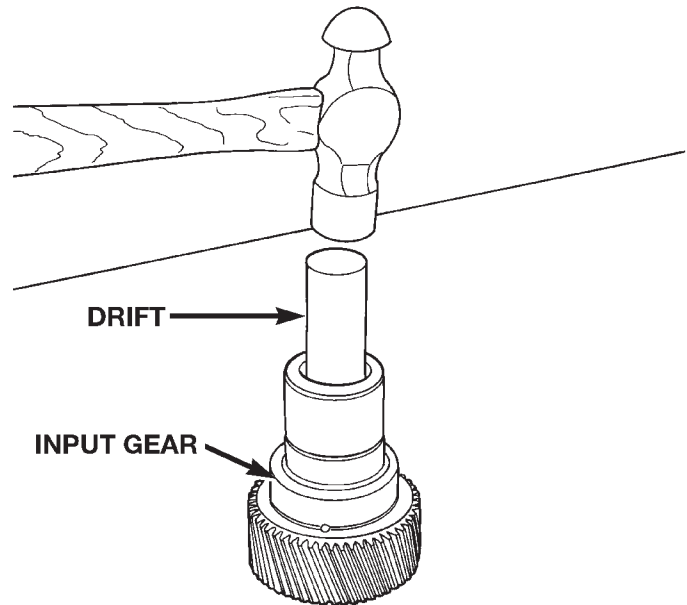


J8921-219

Fig. 53 Seating Input Gear Bearing

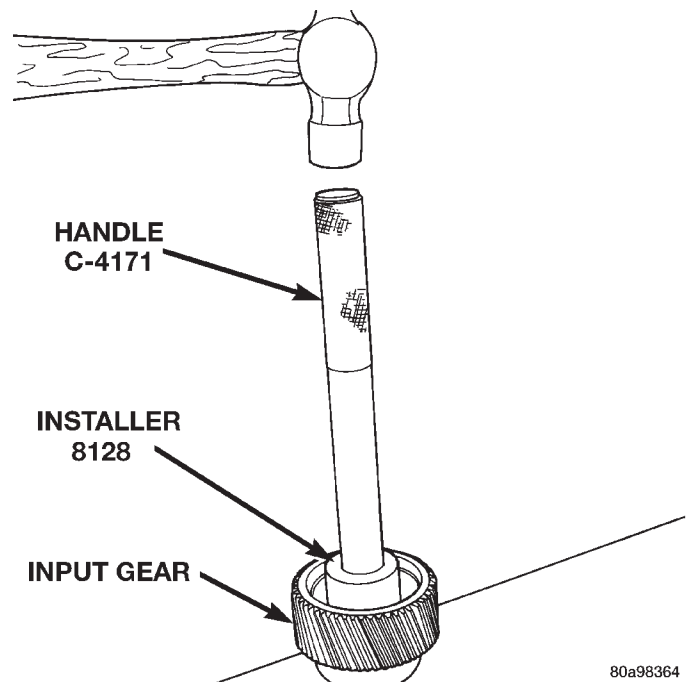
(9) Remove the input gear pilot bearing by inserting a suitably sized drift into the splined end of the input gear and driving the bearing out with the drift and a hammer (Fig. 54).

(10) Install new pilot bearing with Installer 8128 and Handle C-4171 (Fig. 55).



80a11090

Fig. 54 Remove Input Gear Pilot Bearing

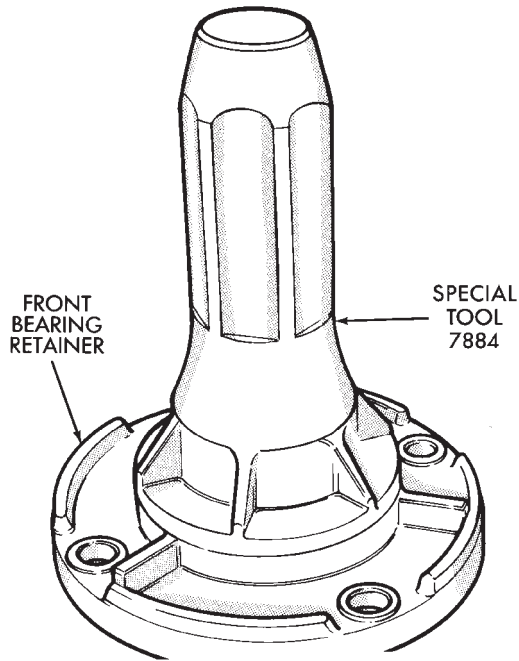


80a98364

Fig. 55 Install Input Gear Pilot Bearing

DISASSEMBLY AND ASSEMBLY (Continued)

(11) Install new seal in front bearing retainer with Installer 7884 (Fig. 56).

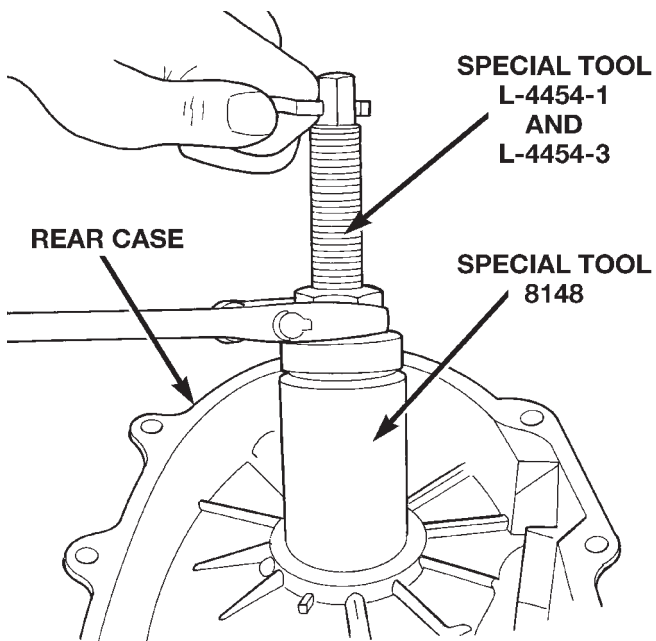


J9521-41

Fig. 56 Front Bearing Retainer Seal Installation

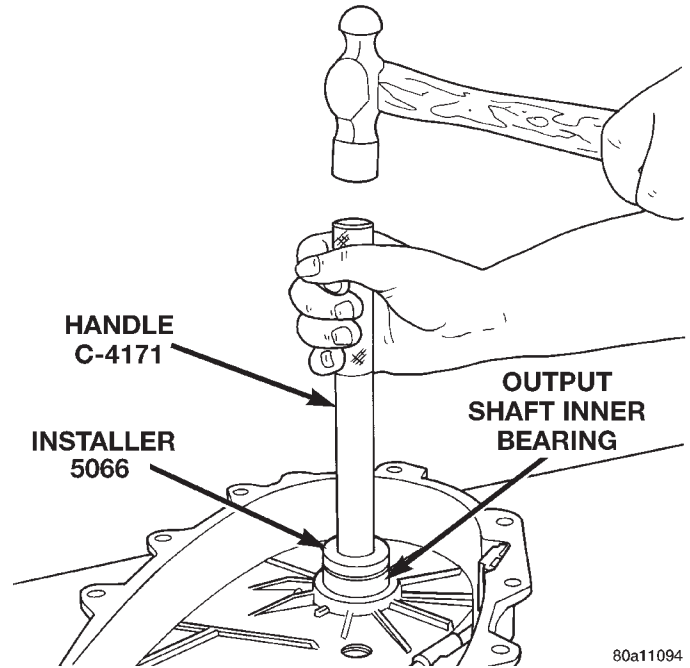
(12) Remove output shaft rear bearing with the screw and jaws from Remover L-4454 and Cup 8148 (Fig. 57).

(13) Install new bearing with Tool Handle C-4171 and Installer 5066 (Fig. 58). Lubricate bearing after installation.



80a98366

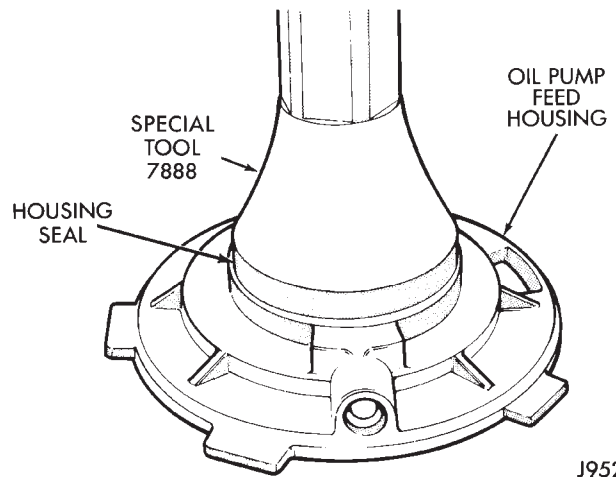
Fig. 57 Remove Front Output Shaft Rear Bearing



80a11094

Fig. 58 Install Front Output Shaft Rear Bearing

(14) Install new seal in oil pump feed housing with Special Tool 7888 (Fig. 59).

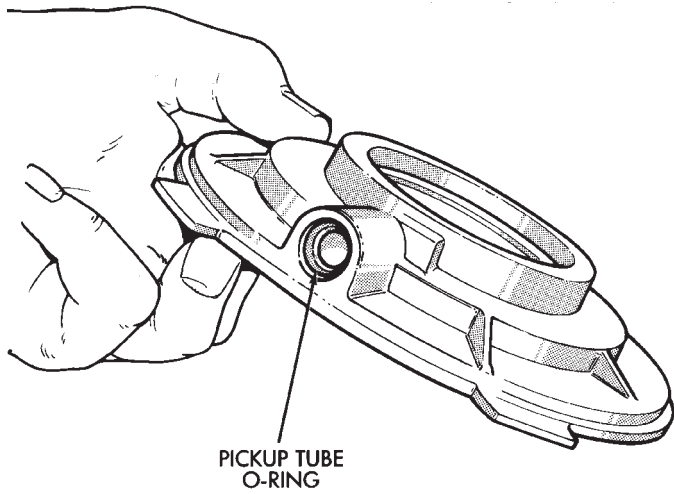


J9521-35

Fig. 59 Oil Pump Seal Installation

DISASSEMBLY AND ASSEMBLY (Continued)

(15) Install new pickup tube O-ring in oil pump (Fig. 60).



PICKUP TUBE O-RING

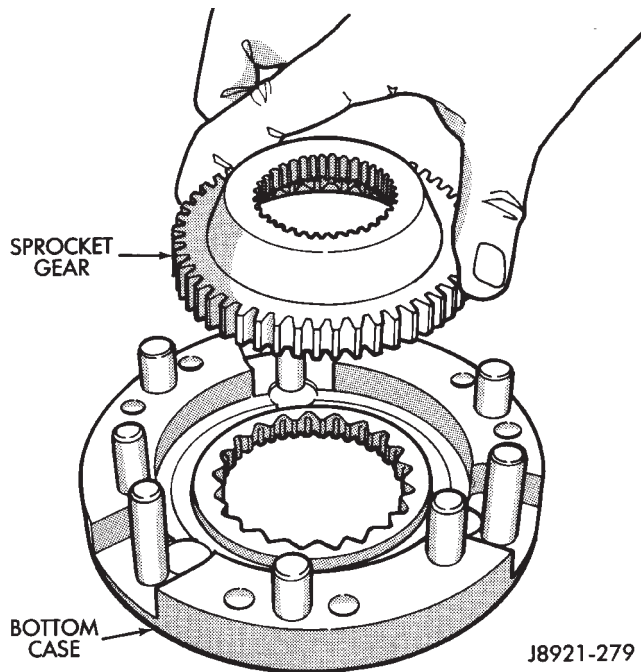
J8921-286

Fig. 60 Pickup Tube O-Ring Installation

DIFFERENTIAL ASSEMBLY

(1) Lubricate differential components with automatic transmission fluid.

(2) Install sprocket gear in differential bottom case (Fig. 61).



SPROCKET GEAR

BOTTOM CASE

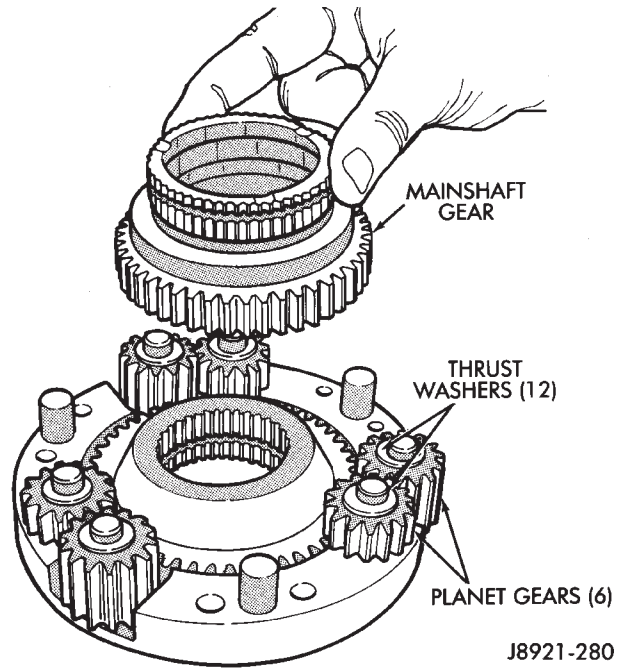
J8921-279

Fig. 61 Installing Differential Sprocket Gear

(3) Install differential planet gears and new thrust washers (Fig. 62). **Be sure thrust washers are installed at top and bottom of each planet gear.**

(4) Install differential mainshaft gear (Fig. 62).

(5) Align and position differential top case on bottom case (Fig. 63). Align using scribe marks made at disassembly.



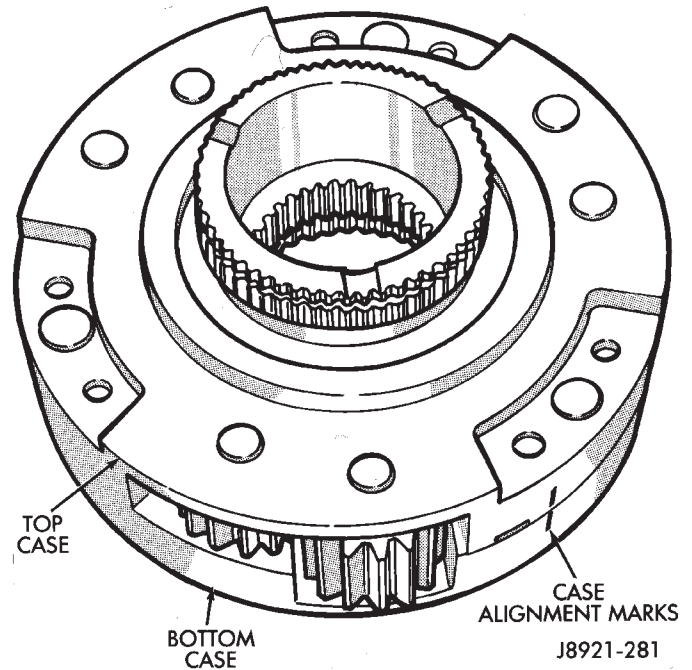
MAINSHAFT GEAR

THRUST WASHERS (12)

PLANET GEARS (6)

J8921-280

Fig. 62 Installing Mainshaft And Planet Gears



TOP CASE

BOTTOM CASE

CASE ALIGNMENT MARKS

J8921-281

Fig. 63 Differential Case Assembly

DISASSEMBLY AND ASSEMBLY (Continued)

(6) While holding differential case halves together, invert the differential and start the differential case bolts.

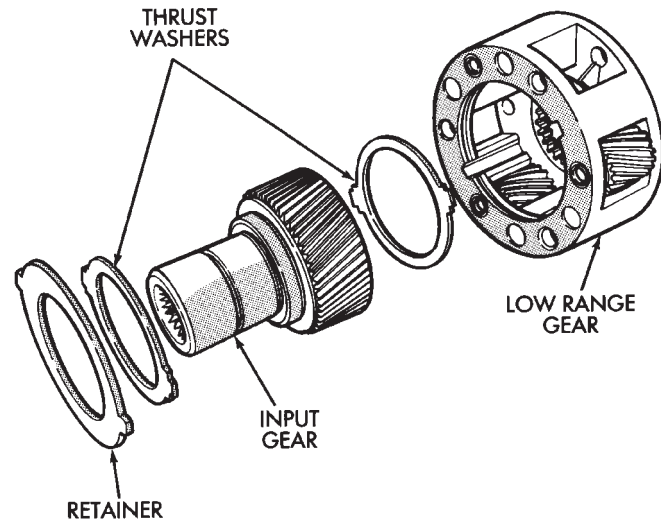
(7) Tighten differential case bolts to specified torque.

INPUT GEAR/LOW RANGE ASSEMBLY

(1) Assemble low range gear, input gear thrust washers, input gear and input gear retainer (Fig. 64).

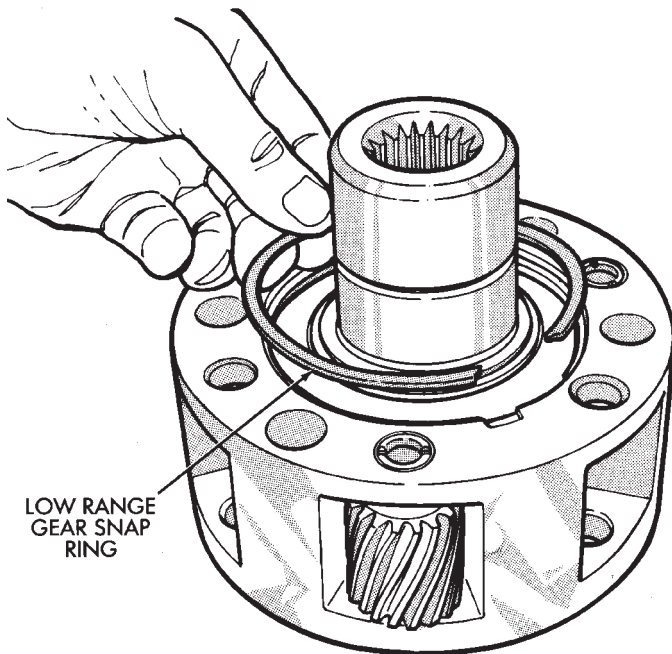
(2) Install low range gear snap ring (Fig. 65).

(5) Press input gear shaft into front bearing.
 (6) Install new input gear snap ring (Fig. 66).



J8921-214

Fig. 64 Low Range And Input Gear Assembly

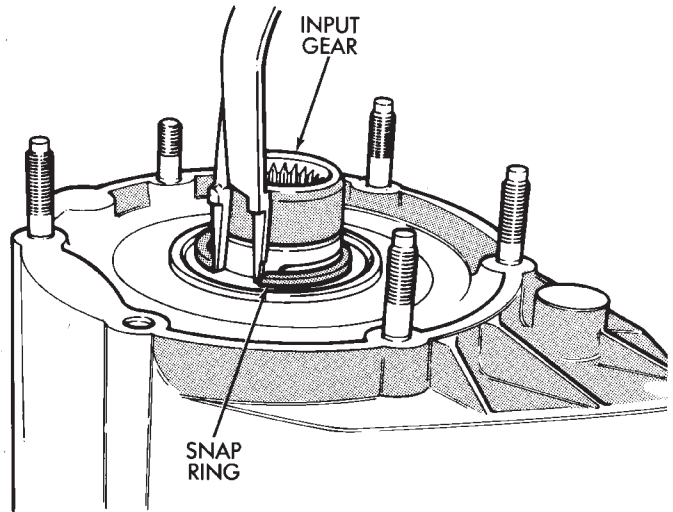


J8921-269

Fig. 65 Install Low Range Gear Snap Ring

(3) Lubricate input gear and low range gears with automatic transmission fluid.

(4) Start input gear shaft into front case bearing.

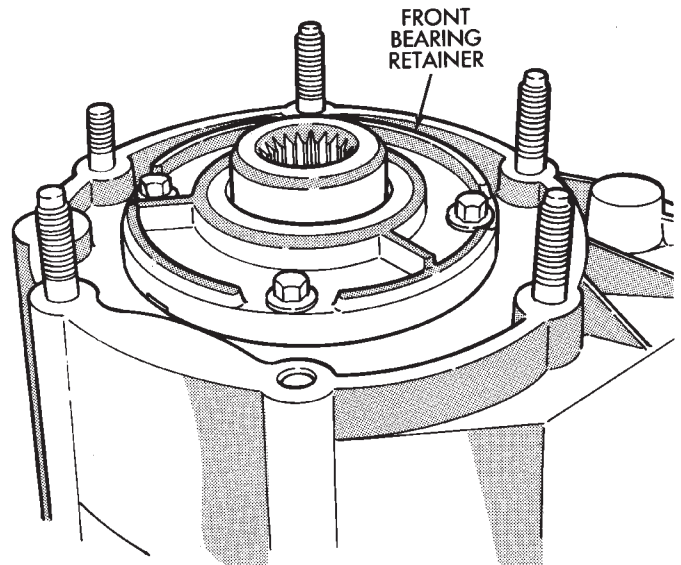


J8921-267

Fig. 66 Input Gear Snap Ring Installation

(7) Apply 3 mm (1/8 in.) wide bead of Mopar® gasket maker or silicone adhesive sealer to seal surface of front bearing retainer.

(8) Install front bearing retainer (Fig. 67). Tighten retainer bolts to 16 ft. lbs. (21 N-m) torque.



J8921-276

Fig. 67 Installing Front Bearing Retainer

DISASSEMBLY AND ASSEMBLY (Continued)

SHIFT FORKS AND MAINSHAFT INSTALLATION

(1) Install new sector shaft O-ring and bushing (Fig. 68).

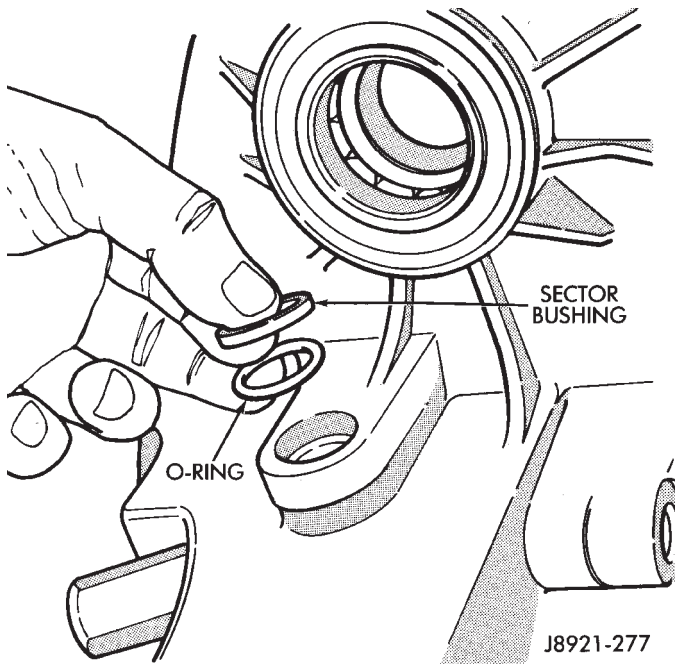
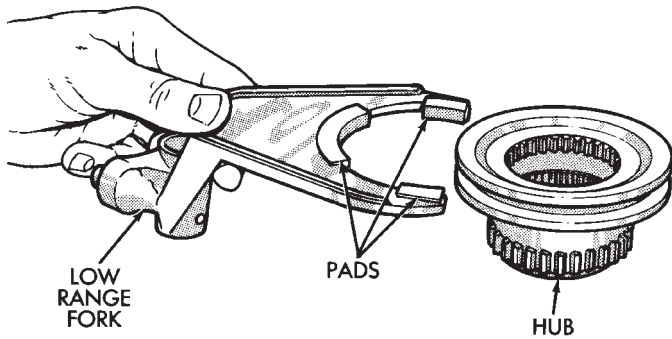


Fig. 68 Sector O-Ring And Bushing Installation

- (2) Install shift sector.
- (3) Install new pads on low range fork, if necessary, (Fig. 69).
- (4) Assemble low range fork and hub (Fig. 69).
- (5) Position low range fork and hub in case. Be sure low range fork pin is engaged in shift sector slot (Fig. 70).



J8921-278

Fig. 69 Assembling Low Range Fork And Hub

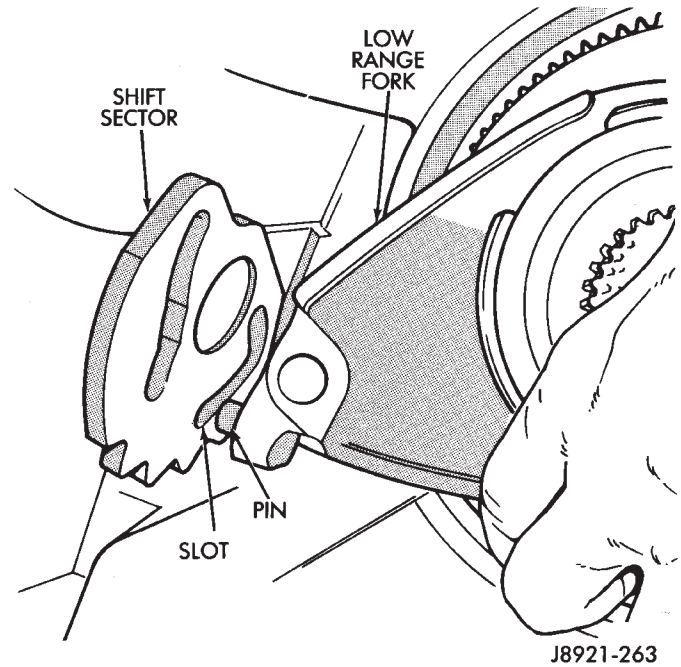


Fig. 70 Positioning Low Range Fork

- (6) Install first mainshaft bearing spacer on mainshaft (Fig. 71).
- (7) Install bearing rollers on mainshaft (Fig. 71). **Coat bearing rollers with generous quantity of petroleum jelly to hold them in place.**
- (8) Install remaining bearing spacer on mainshaft (Fig. 71). Do not displace any bearings while installing spacer.

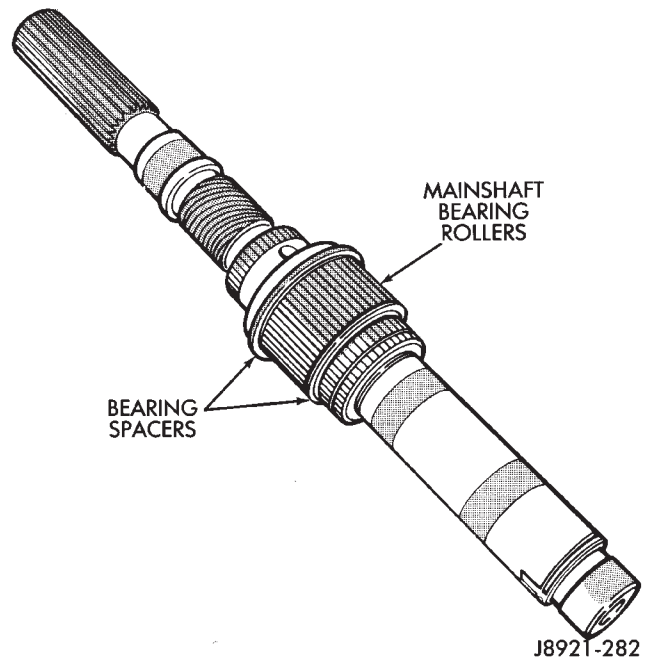
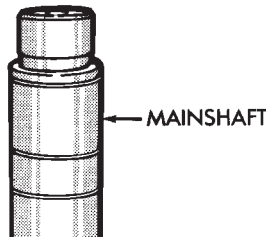
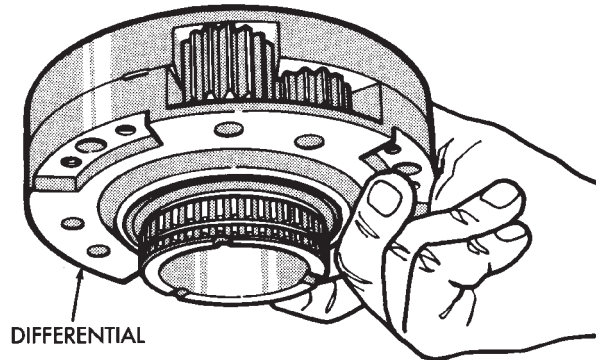


Fig. 71 Installing Mainshaft Bearing Rollers and Spacers

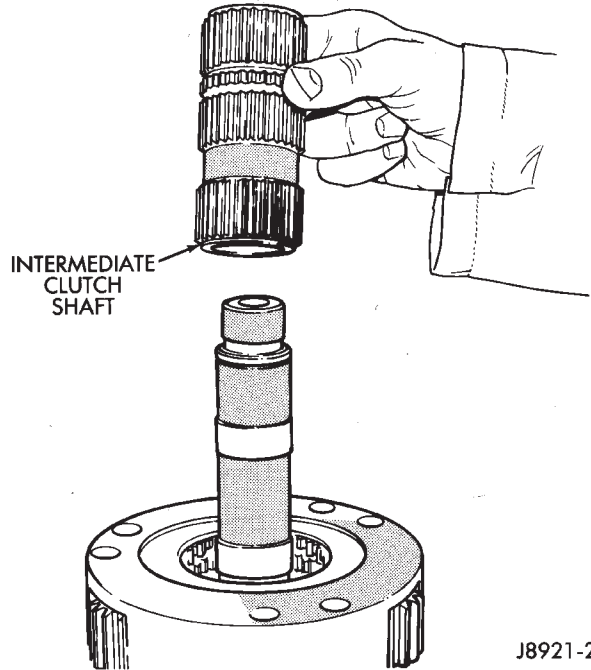
DISASSEMBLY AND ASSEMBLY (Continued)

- (9) Install differential (Fig. 72). **Do not displace mainshaft bearings when installing differential.**
- (10) Install differential snap-ring (Fig. 73).
- (11) Install intermediate clutch shaft (Fig. 74).



J8921-283

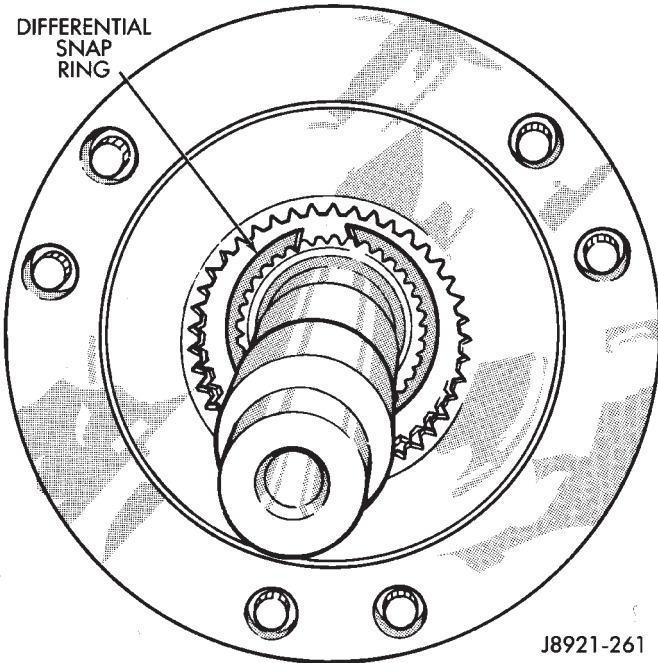
Fig. 72 Differential Installation



J8921-260

Fig. 74 Installing Intermediate Clutch Shaft

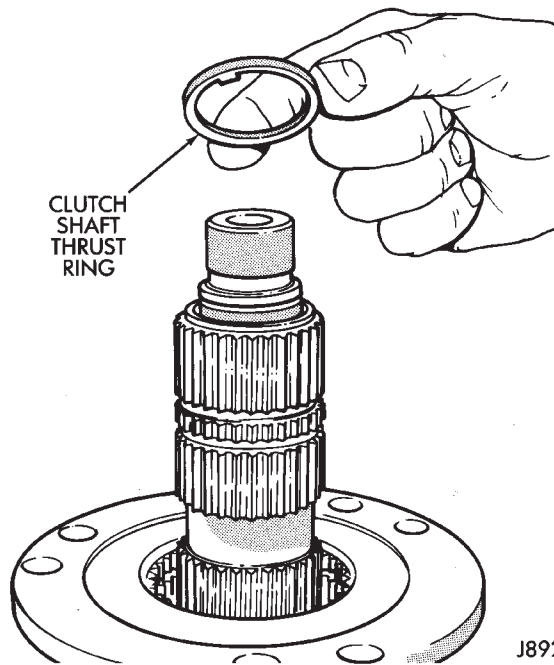
(14) Inspect mode fork assembly (Fig. 77). Replace pads and bushing if necessary. Replace fork tube if bushings inside tube are worn or damaged. Also check springs and slider bracket (Fig. 77). Replace worn, damaged components.



J8921-261

Fig. 73 Installing Differential Snap-Ring

- (12) Install clutch shaft thrust washer (Fig. 75).
- (13) Install clutch shaft snap-ring (Fig. 76).



J8921-259

Fig. 75 Installing Clutch Shaft Thrust Washer

DISASSEMBLY AND ASSEMBLY (Continued)

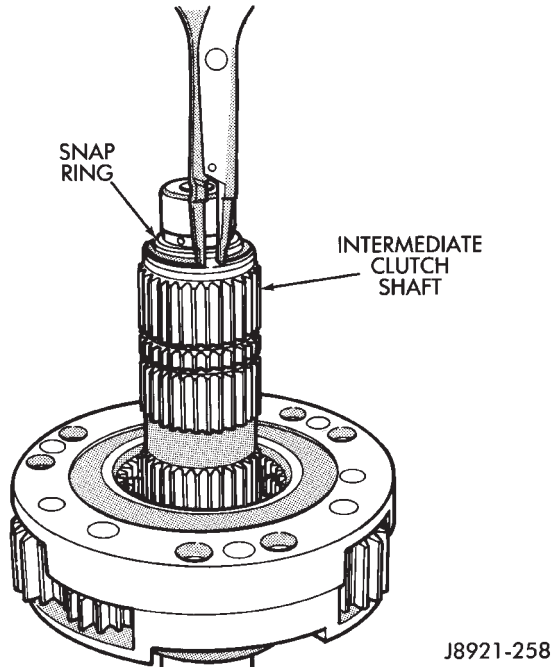


Fig. 76 Installing Clutch Shaft Snap-Ring

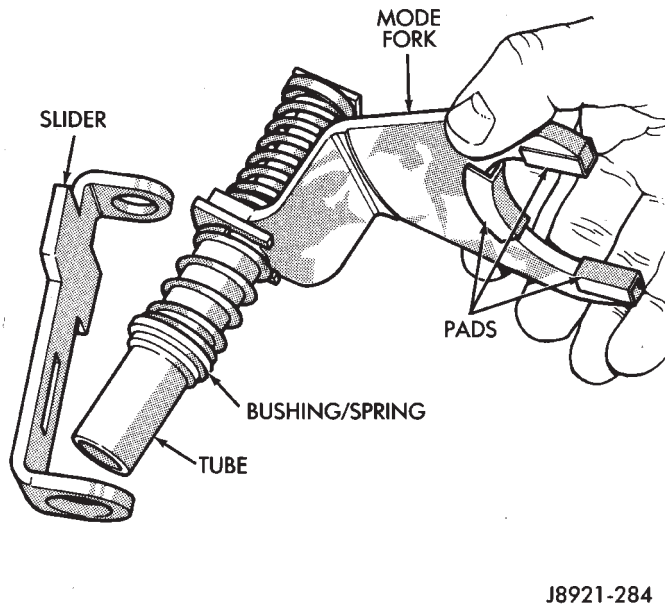


Fig. 77 Mode Fork Assembly Inspection

(15) Install mode sleeve in mode fork (Fig. 78). Then install assembled sleeve and fork on mainshaft. Be sure mode sleeve splines are engaged in differential splines.

(16) Install mode fork and mainshaft assembly in case (Fig. 79). Rotate mainshaft slightly to engage shaft with low range gears.

(17) Rotate mode fork pin into shift sector slot.

(18) Install shift rail (Fig. 80). **Be sure rail is seated in both shift forks.**

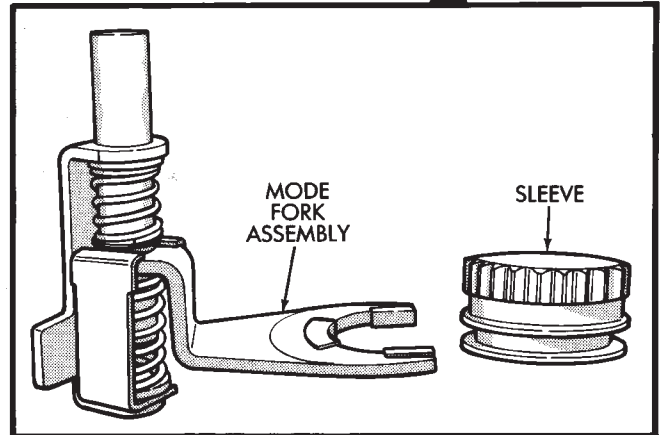
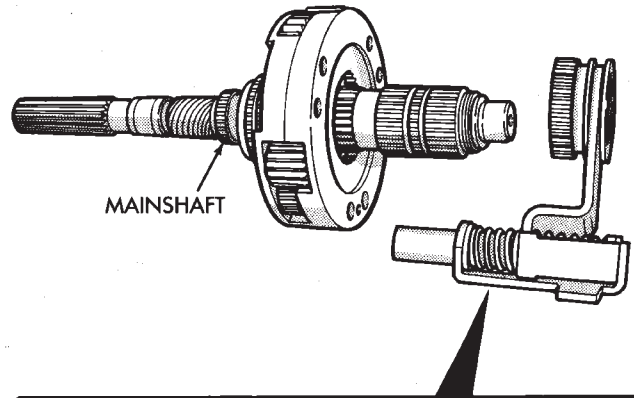


Fig. 78 Installing Mode Fork And Sleeve

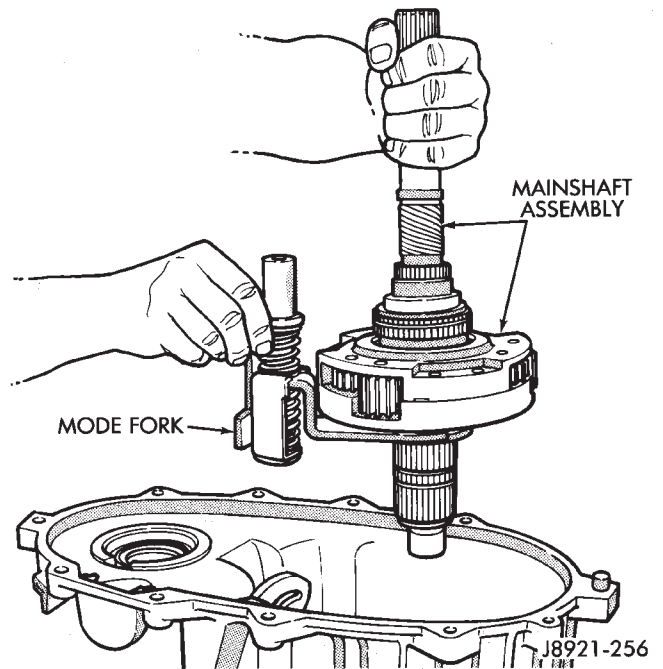


Fig. 79 Assembled Mainshaft And Mode Fork Installation

DISASSEMBLY AND ASSEMBLY (Continued)

(19) Rotate shift sector to align lockpin hole in low range fork with access hole in case.

(20) Insert an easy-out in range fork lockpin to hold it securely for installation (Fig. 81). **Lockpin is slightly tapered on one end. Insert tapered end into fork and rail.**

(21) Insert lockpin through access hole and into shift fork (Fig. 81). Then remove easy-out and seat the pin with pin punch.

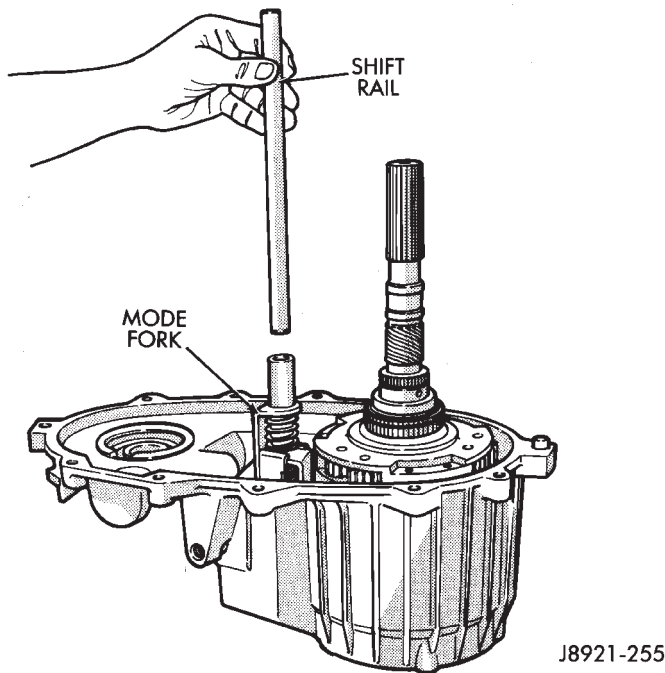


Fig. 80 Shift Rail Installation

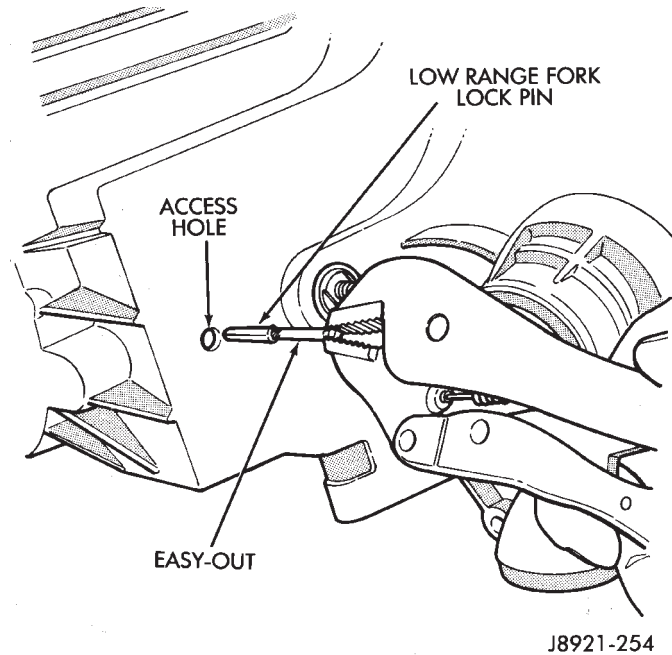


Fig. 81 Installing Low Range Fork Lockpin

(22) Install plug in lockpin access hole.

(23) Install detent plunger, detent spring and detent plug in case (Fig. 82).

FRONT OUTPUT SHAFT AND DRIVE CHAIN INSTALLATION

(1) Install front output shaft (Fig. 83).

(2) Install drive chain (Fig. 83). Engage chain with front output shaft sprocket teeth.

(3) Install drive sprocket (Fig. 83). Engage drive sprocket teeth with chain. Then engage sprocket splines with mainshaft splines

(4) Install drive sprocket snap-ring (Fig. 84)..

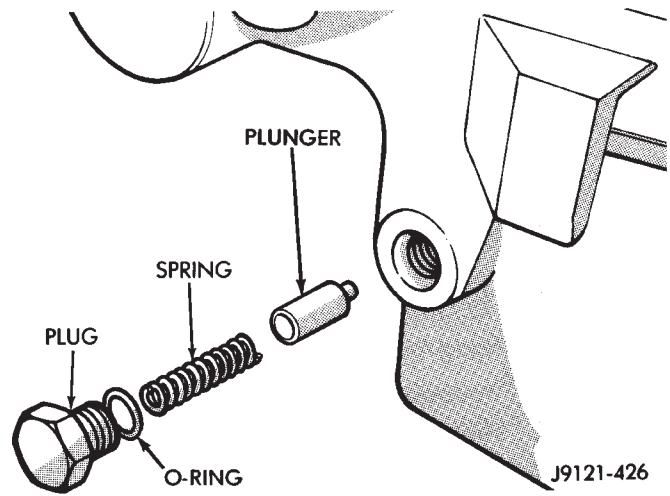


Fig. 82 Detent Pin, Spring And Plug Installation

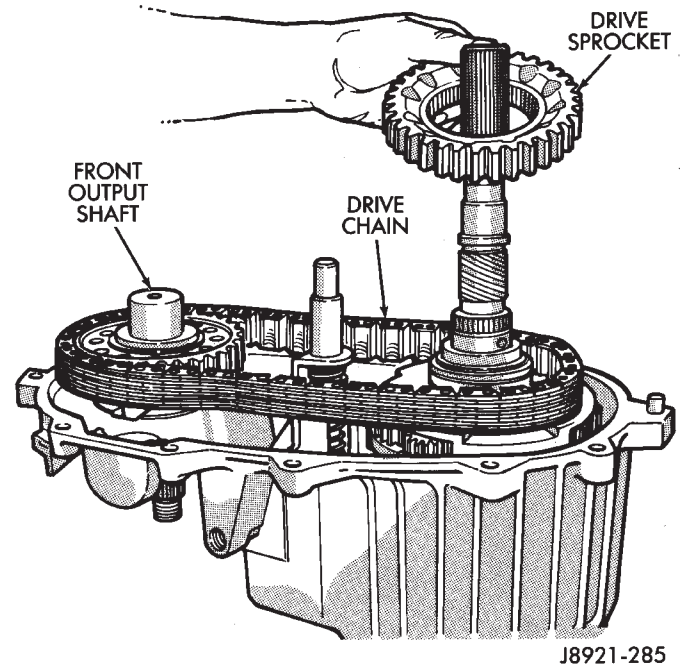


Fig. 83 Drive Chain And Sprocket Installation

OIL PUMP AND REAR CASE INSTALLATION

(1) Insert oil pickup tube in oil pump and attach oil screen and connector hose to pickup tube. Then

DISASSEMBLY AND ASSEMBLY (Continued)

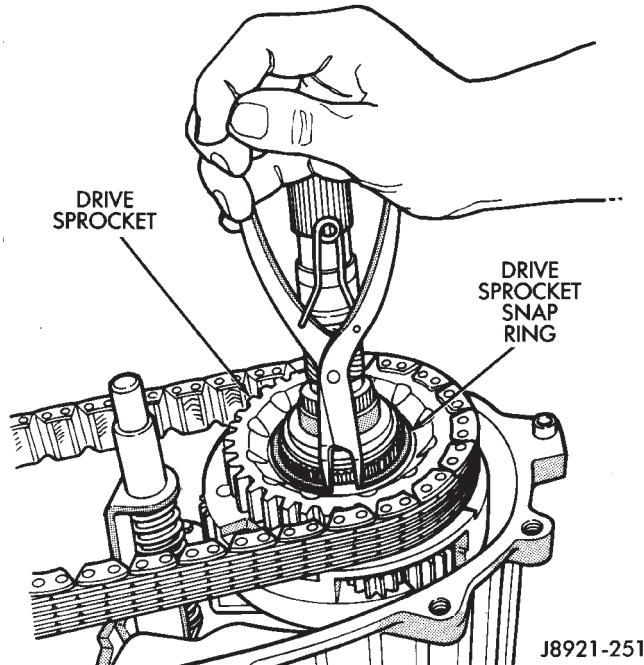


Fig. 84 Drive Sprocket Snap-Ring Installation

install assembled pump, tube and screen in rear case (Fig. 85). Be sure screen is seated in case slot as shown.

- (2) Install magnet in front case pocket (Fig. 86).

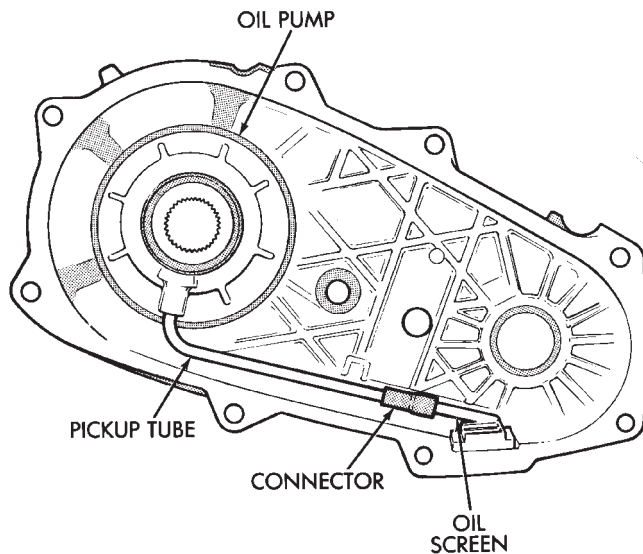


Fig. 85 Oil Screen And Pickup Tube Installation

- (3) Apply 3 mm (1/8 in.) wide bead of Mopar gasket maker or silicone adhesive sealer to seal surface of front case.

- (4) Align and install rear case on front case. Be sure case locating dowels are in place and that main-shaft splines are engaged in oil pump inner gear.

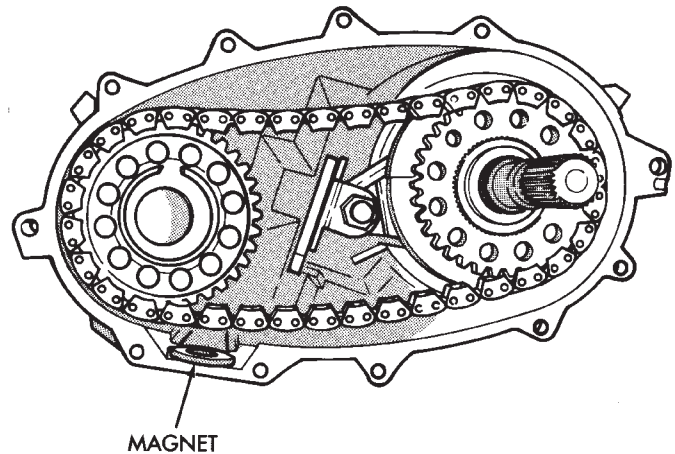


Fig. 86 Installing Case Magnet

- (5) Install and tighten front case-to-rear case bolts to 41 N·m (30 ft. lbs.) torque. **Be sure to install a washer under each bolt used at case dowel locations.**

REAR RETAINER INSTALLATION

- (1) Remove rear bearing in retainer using Installer 8128 and Handle C-4171.

- (2) Install rear bearing in retainer with Tools C-4171 and 5064 (Fig. 87).

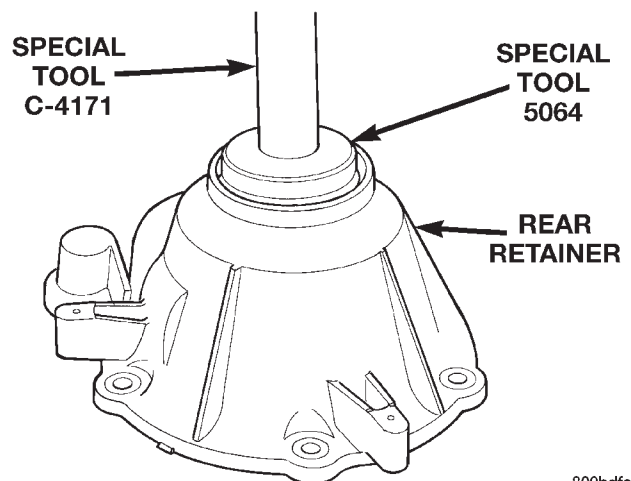


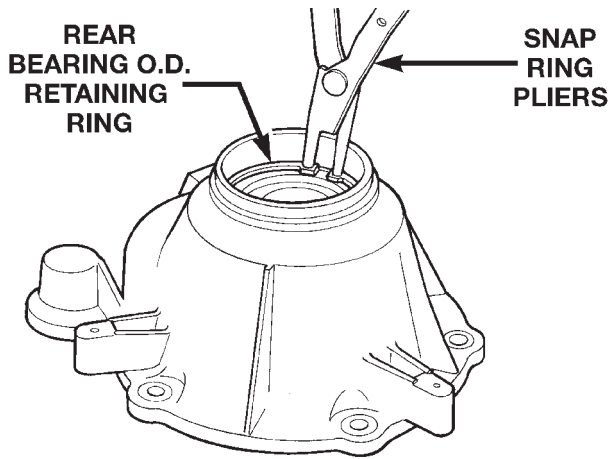
Fig. 87 Installing Rear Bearing In Retainer

- (3) Install rear bearing O.D. retaining ring with snap-ring pliers (Fig. 88). Be sure retaining ring is fully seated in retainer groove.

- (4) Apply bead of Mopar® Sealer P/N 82300234, or Loctite™ Ultra Gray, to mating surface of rear retainer. Sealer bead should be a maximum of 3/16 in.

- (5) Install rear retainer on rear case. Tighten retainer bolts to 20–27 N·m (15–20 ft. lbs.) torque.

DISASSEMBLY AND ASSEMBLY (Continued)



800bdfae

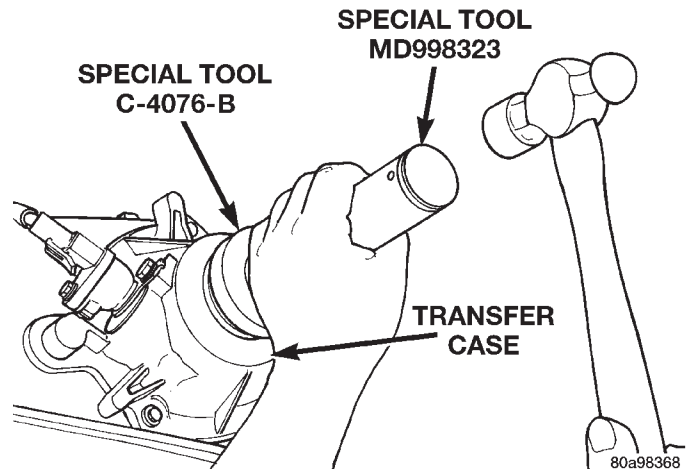
Fig. 88 Rear Bearing Retaining Ring Installation

(6) Install rear bearing I.D. retaining ring and spacer on output shaft.

(7) Apply liberal quantity of petroleum jelly to new rear seal and to output shaft. Petroleum jelly is needed to protect seal lips during installation.

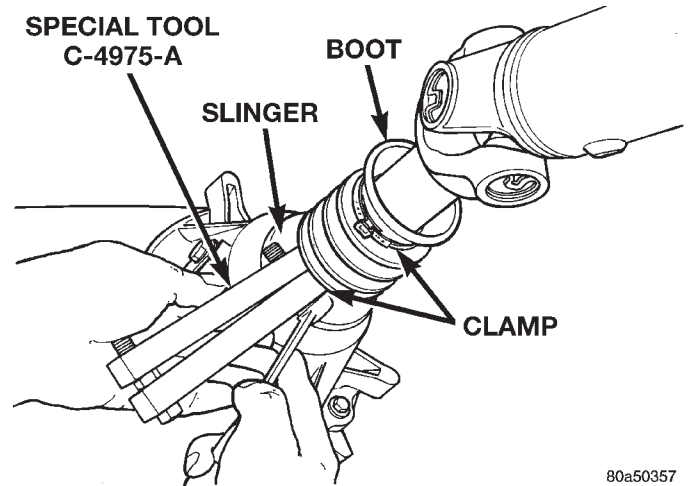
(8) Slide seal onto Seal Protector 6992 (Fig. 89). Slide seal protector and seal onto output shaft.

(9) Slide Installer C-4076-B onto seal protector with the recessed side of the tool toward the seal. Drive seal into rear bearing retainer with installer C-4076-B and handle MD-998323 (Fig. 90).



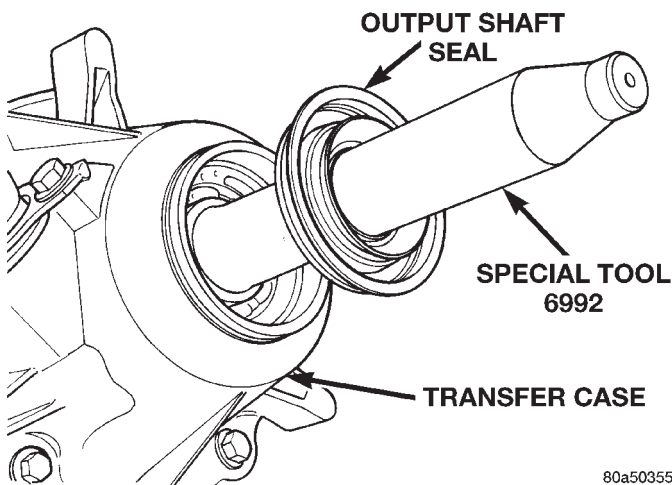
80a98368

Fig. 90 Rear Seal Installation



80a50357

Fig. 91 Slinger Boot Installation



80a50355

Fig. 89 Output Shaft Seal and Protector

(10) Install rear slinger with installer C-4076-A and handle MD-998323 (Fig. 90).

(11) Install boot on output shaft slinger and crimp retaining clamp with tool C-4975-A (Fig. 91).

FRONT YOKE AND SWITCH INSTALLATION

(1) Install indicator switch in front case. Tighten switch to 20–34 N·m (15–25 ft. lbs.) torque.

(2) Lubricate yoke hub with transmission fluid and install yoke on front shaft.

- (3) Install new seal washer on front shaft.
- (4) Install yoke on front shaft. Secure yoke with new nut.

CLEANING AND INSPECTION

NV242 TRANSFER CASE

Clean the transfer case parts with a standard parts cleaning solvent. Remove all traces of sealer from the cases and retainers with a scraper and all purpose cleaner. Use compressed air to remove solvent residue from oil feed passages in the case halves, retainers, gears, and shafts.

The oil pickup screen can be cleaned with solvent. Shake excess solvent from the screen after cleaning and allow it to air dry. Do not use compressed air.

MAINSHAFT/SPROCKET/HUB INSPECTION

Inspect the splines on the hub and shaft and the teeth on the sprocket. Minor nicks and scratches can

CLEANING AND INSPECTION (Continued)

be smoothed with an oilstone. However, replace any part is damaged.

Check the contact surfaces in the sprocket bore and on the mainshaft. Minor nicks and scratches can be smoothed with 320–400 grit emery cloth but do not try to salvage the shaft if nicks or wear is severe.

INPUT GEAR AND PLANETARY CARRIER

Check the teeth on the gear (Fig. 92). Minor nicks can be dressed off with an oilstone but replace the gear if any teeth are broken, cracked, or chipped. The bearing surface on the gear can be smoothed with 300–400 grit emery cloth if necessary.

Examine the carrier body and pinion gears for wear or damage. The carrier will have to be replaced as an assembly if the body, pinion pins, or pinion gears are damaged.

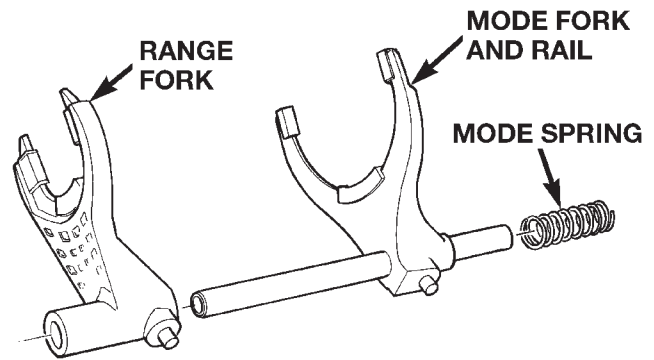
Check the lock ring and both thrust washers for wear or cracks. Replace them if necessary. Also replace the lock retaining ring if bent, distorted, or broken.

SHIFT FORKS/HUBS/SLEEVES

Check condition of the shift forks and mode fork shift rail (Fig. 93). Minor nicks on the shift rail can be smoothed with 320–400 grit emery cloth.

Inspect the shift fork wear pads. The mode fork pads are serviceable and can be replaced if necessary. The range fork pads are also serviceable.

Check both of the sleeves for wear or damage, especially on the interior teeth. Replace the sleeves if wear or damage is evident.



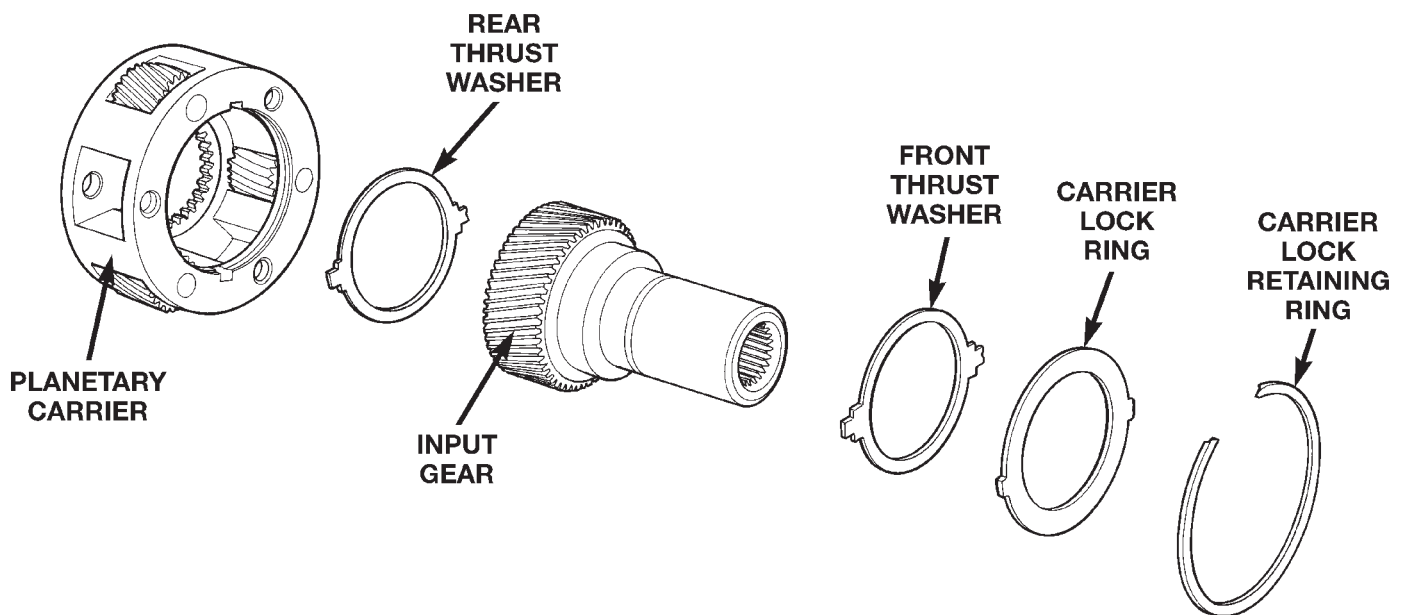
80010948

Fig. 93 Shift forks**REAR RETAINER/BEARING/ SEAL/SLINGER/ BOOT**

Inspect the retainer components (Fig. 94). Replace the bearing if rough or noisy. Check the retainer for cracks or wear in the bearing bore. Clean the retainer sealing surfaces with a scraper and all purpose cleaner. This will ensure proper adhesion of the sealer during reassembly.

Replace the slinger and seal outright; do not reuse either part.

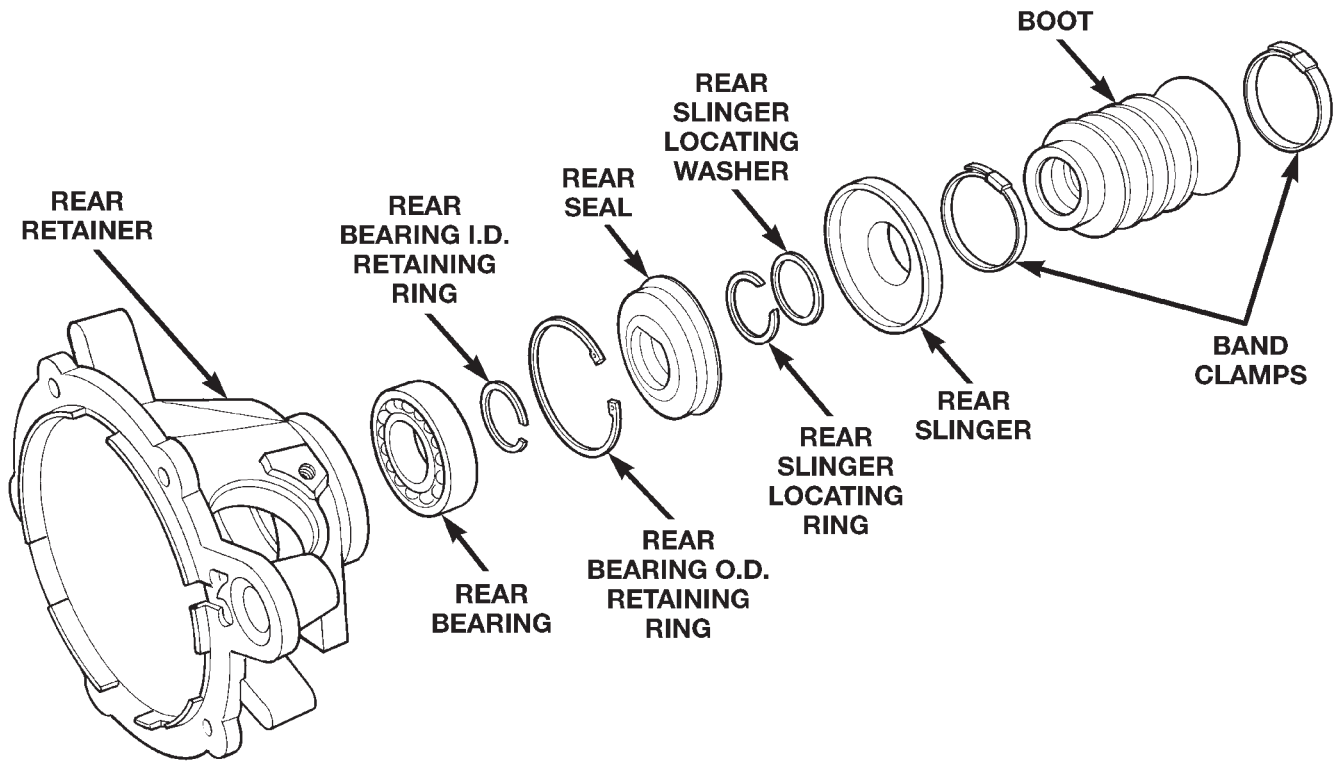
Inspect the retaining rings and washers. Replace any part if distorted, bent, or broken. Reuse is not recommended. Also replace the boot if cut or torn. Replace the boot band clamps, do not reuse them.



8001b75f

Fig. 92 Input Gear And Carrier Components

CLEANING AND INSPECTION (Continued)



80010949

Fig. 94 Rear Retainer Components

REAR OUTPUT SHAFT/YOKE/DRIVE CHAIN

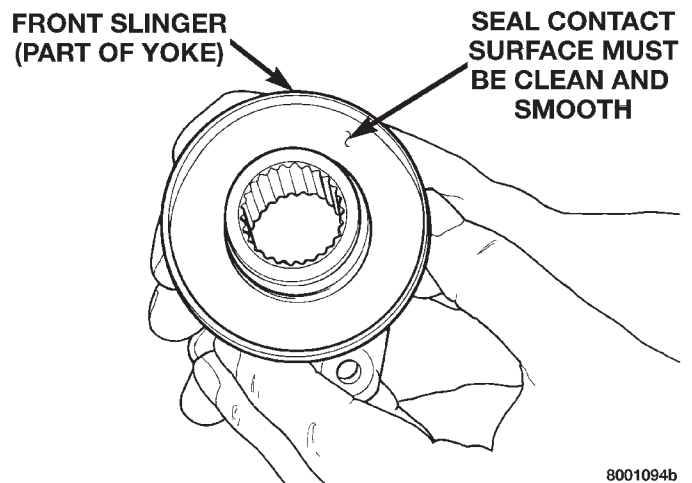
Check condition of the seal contact surfaces of the yoke slinger (Fig. 95). This surface must be clean and smooth to ensure proper seal life. Replace the yoke nut and seal washer as neither part should be reused.

Inspect the shaft threads, sprocket teeth, and bearing surfaces. Minor nicks on the teeth can be smoothed with an oilstone. Use 320–400 grit emery to smooth minor scratches on the shaft bearing surfaces. Rough threads on the shaft can be chased if necessary. Replace the shaft if the threads are damaged, bearing surfaces are scored, or if any sprocket teeth are cracked or broken.

Examine the drive chain and shaft bearings. Replace the chain and both sprockets if the chain is stretched, distorted, or if any of the links bind. Replace the bearings if rough, or noisy.

LOW RANGE ANNULUS GEAR

Inspect annulus gear condition carefully. The gear is only serviced as part of the front case. If the gear is damaged, it will be necessary to replace the gear and front case as an assembly. Do not attempt to remove the gear (Fig. 96).



8001094b

Fig. 95 Seal Contact Surface Of Yoke Slinger FRONT-REAR CASES AND FRONT RETAINER

Inspect the cases and retainer for wear and damage. Clean the sealing surfaces with a scraper and all purpose cleaner. This will ensure proper sealer adhesion at assembly. Replace the input retainer seal; do not reuse it.

Check case condition. If leaks were a problem, look for gouges and severe scoring of case sealing surfaces. Also make sure the front case mounting studs are in good condition.

CLEANING AND INSPECTION (Continued)

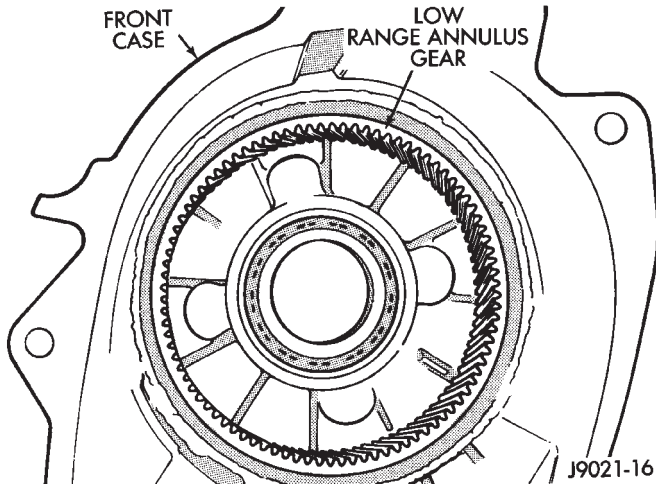


Fig. 96 Low Range Annulus Gear

Check the front case mounting studs and vent tube. The tube can be secured with Loctite™ 271 or 680 if loose. The stud threads can be cleaned up with a die if necessary. Also check condition of the fill/drain plug threads in the rear case. The threads can be repaired with a thread chaser or tap if necessary. Or the threads can be repaired with Helicoil stainless steel inserts if required.

OIL PUMP/OIL PICKUP

Examine the oil pump pickup parts. Replace the pump if any part appears to be worn or damaged. Do not disassemble the pump as individual parts are not available. The pump is only available as a complete assembly. The pickup screen, hose, and tube are the only serviceable parts and are available separately.

ADJUSTMENTS

SHIFT LINKAGE ADJUSTMENT

- (1) Shift transfer case into 4L position.
- (2) Raise vehicle.
- (3) Loosen lock bolt on adjusting trunnion (Fig. 97).
- (4) Be sure linkage rod slides freely in trunnion. Clean rod and apply spray lube if necessary.
- (5) Verify that transfer case range lever is fully engaged in 4L position.
- (6) Tighten adjusting trunnion lock bolt.
- (7) Lower vehicle.

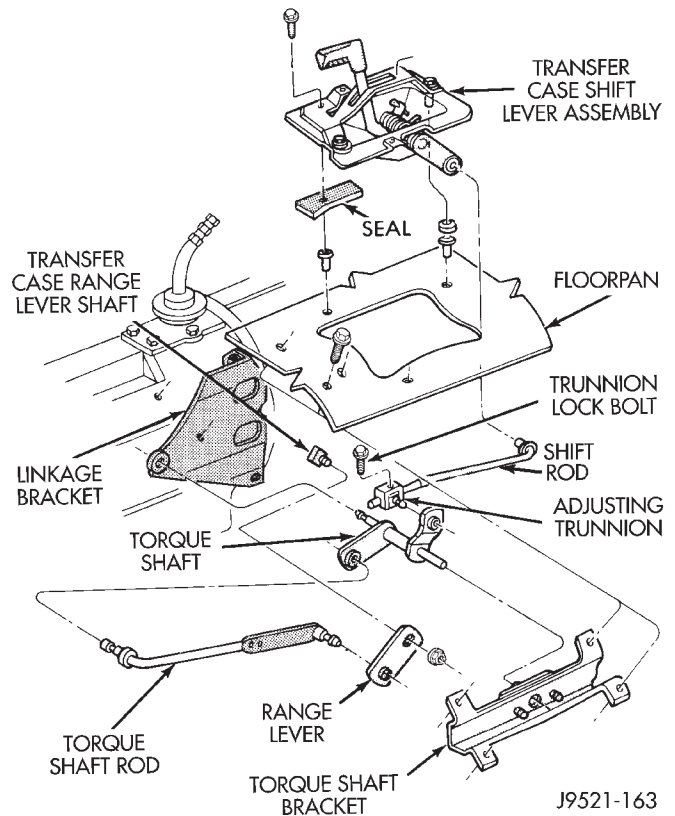


Fig. 97 Shift Linkage

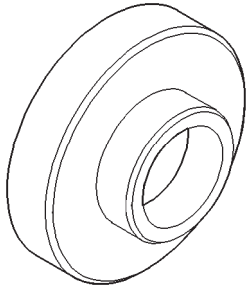
SPECIFICATIONS

TORQUE

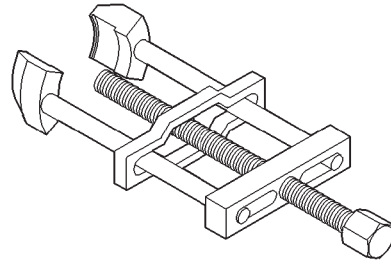
DESCRIPTION	TORQUE
Plug, Detent16–24 N·m (12–18 ft. lbs.)
Bolt, Diff. Case17–27 N·m (15–24 ft. lbs.)
Plug, Drain/Fill20–25 N·m (15–25 ft. lbs.)
Bolt, Front Brg. Retainer. .16–27 N·m (12–20 ft. lbs.)	
Bolt, Case Half35–46 N·m (26–34 ft. lbs.)
Nut, Front Yoke122–176 N·m (90–130 ft. lbs.)
Screw, Oil Pump1.2–1.8 N·m (12–15 in. lbs.)
Nut, Range Lever27–34 N·m (20–25 ft. lbs.)
Bolt, Rear Retainer35–46 N·m (26–34 ft. lbs.)
Nuts, Mounting.35 N·m (26 ft. lbs.)
Bolts, U-Joint19 N·m (17 ft. lbs.)

SPECIAL TOOLS

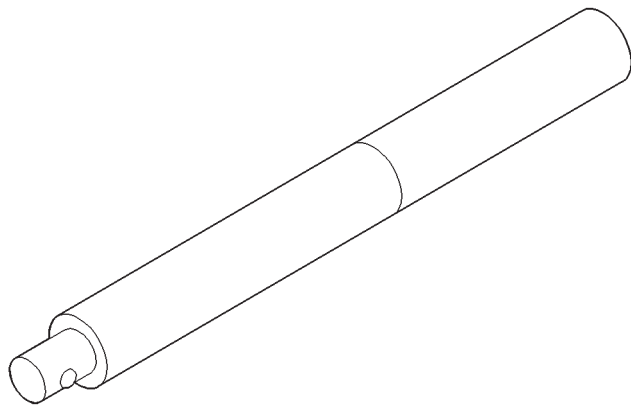
SPECIAL TOOLS—NV242



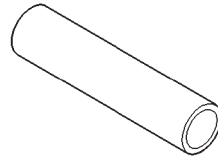
Installer—C-4076-B



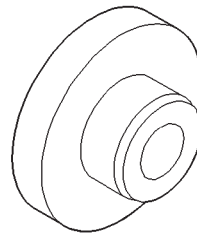
Puller, Slinger—MD-998056-A



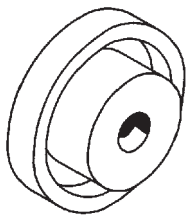
Handle, Universal—C-4171



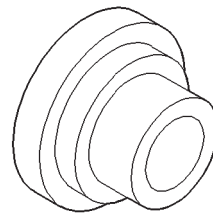
Installer—MD-998323



Installer, Bearing—5064

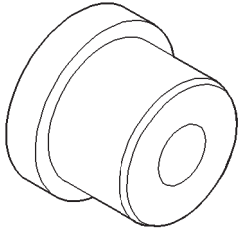


Remover—C-4210

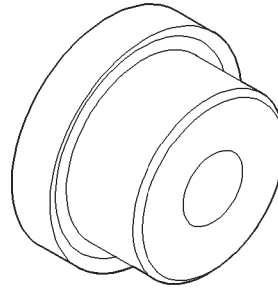


Installer—8128

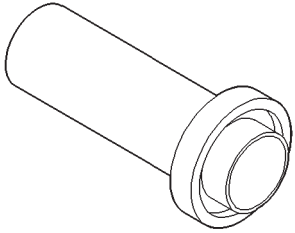
SPECIAL TOOLS (Continued)



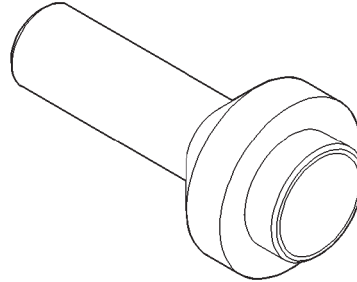
Installer—5066



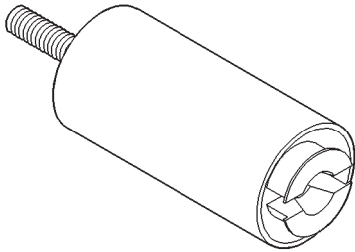
Installer, Input Gear Bearing—7829-A



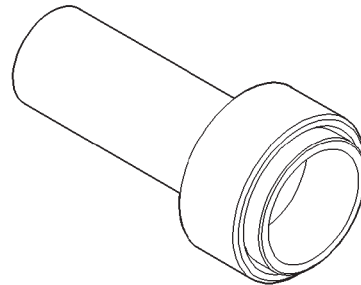
Installer—6952-A



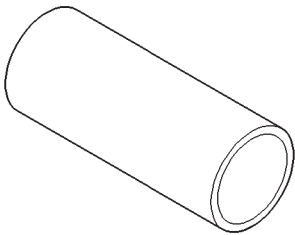
Installer, Seal—7884



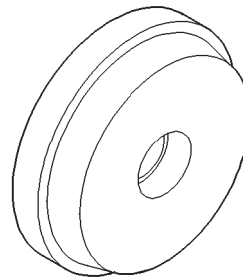
Remover—L-4454



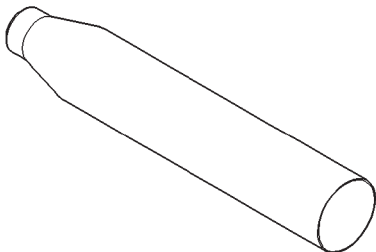
Installer, Pump Housing Seal—7888



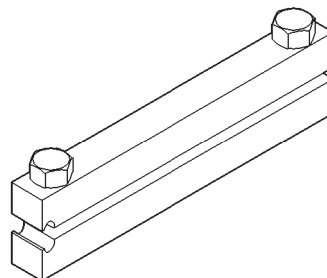
Cup—8148



Installer, Bearing—8033-A



Seal Protector—6992



Installer, Boot Clamp—C-4975-A

NV249 TRANSFER CASE

INDEX

	page		page
GENERAL INFORMATION		TRANSFER CASE	273
GENERAL INFORMATION	271	DISASSEMBLY AND ASSEMBLY	
RECOMMENDED LUBRICANT AND		NV249 TRANSFER CASE	276
FILL LEVEL	272	CLEANING AND INSPECTION	
TRANSFER CASE IDENTIFICATION	271	NV249 COMPONENTS	291
DIAGNOSIS AND TESTING		ADJUSTMENTS	
NV249 DIAGNOSIS	272	SHIFT LINKAGE ADJUSTMENT	293
REMOVAL AND INSTALLATION		SPECIFICATIONS	
FRONT OUTPUT SHAFT SEAL	274	TORQUE	293
REAR RETAINER BUSHING AND SEAL	275	SPECIAL TOOLS	
SHIFT LEVER	273	NV249 TRANSFER CASE	294
SPEEDOMETER	273		

GENERAL INFORMATION

GENERAL INFORMATION

The NV249 (Fig. 1) is an on-demand 4-wheel drive transfer case with two operating ranges and a neutral position.

Operating ranges are 4-high and 4-low. The 4-low range is used for extra pulling power in off-road situations.

Engine torque is distributed to the front and rear axles through a viscous coupling. Nearly all the available engine torque is directed to the rear wheels during normal driving situations. When slippery conditions are encountered, the variable viscous directs torque to the front wheels as necessary. The NV249 low range is provided by a gear reduction system for

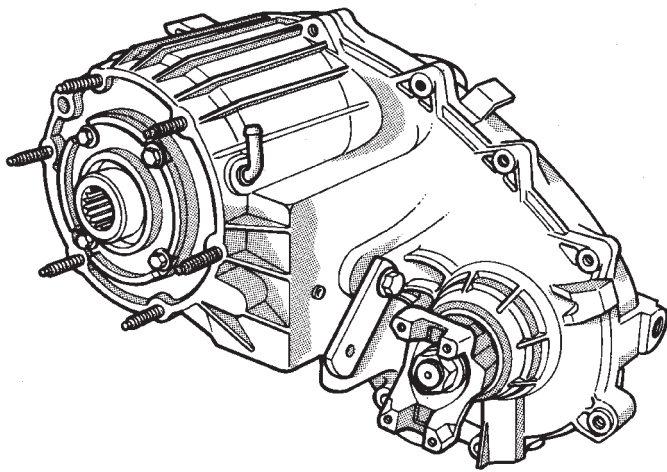
increased low speed, off-road torque capability. This range is designed for temporary use only.

Transfer case operating ranges are selected with a floor mounted shift lever. The shift lever is connected to the transfer case range lever by an adjustable linkage rod. Range positions are marked on the shifter bezel plate.

TRANSFER CASE IDENTIFICATION

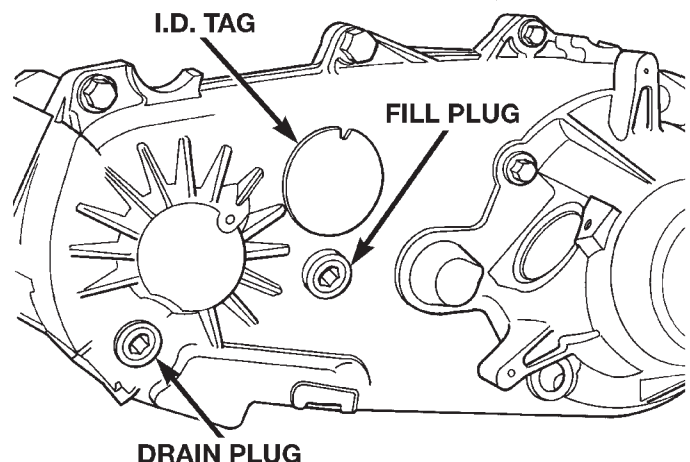
A circular I.D. tag is attached to the rear case of each NV249 transfer case (Fig. 2). The tag provides the transfer case model number, assembly number, serial number and low range ratio.

The transfer case serial number also represents the date of build.



J8921-243

Fig. 1 NV249 Transfer Case



80b09a60

Fig. 2 Transfer Case I.D. Tag

GENERAL INFORMATION (Continued)**RECOMMENDED LUBRICANT AND FILL LEVEL**

Mopar® Dexron II, or ATF Plus are the only lubricants recommended for the NV249 transfer case. Approximate fluid refill capacity is approximately 1.18 liters (2.50 pints).

The fill and drain plugs are both in the rear case. Correct fill level is to the bottom edge of the fill plug

hole. Be sure that the vehicle is level to ensure an accurate fluid level check.

DIAGNOSIS AND TESTING**NV249 DIAGNOSIS**

Condition	Possible Cause	Correction
TRANSFER CASE DIFFICULT TO SHIFT OR WILL NOT SHIFT INTO DESIRED RANGE	<ul style="list-style-type: none"> (a) Vehicle speed too great to permit shifting. (b) If vehicle was operated for extended period in 4H mode on dry paved surface, driveline torque load may cause difficulty. (c) Transfer case external shift linkage binding. (d) Insufficient or incorrect lubricant. (e) Internal components binding, worn or damaged. 	<ul style="list-style-type: none"> (a) Stop vehicle and shift into desired range. Or reduce speed to 3-4 km/h (2-3 mph) before attempting to shift. (b) Stop vehicle, shift transmission to neutral, shift transfer case to 2H mode and operate vehicle on 2H on dry paved surface. (c) Lubricate, repair or replace linkage, or tighten loosen components as necessary. (d) Drain and refill to edge of fill hole with MOPAR ATF PLUS (Type 7176) or DEXRON II Automatic Transmission Fluid. (e) Disassemble unit and replace worn or damaged components as necessary.
TRANSFER CASE NOISY IN ALL DRIVE MODES	<ul style="list-style-type: none"> (a) Insufficient or incorrect lubricant. 	<ul style="list-style-type: none"> (a) Drain and refill to edge of fill hole with MOPAR ATF PLUS (Type 7176) or DEXRON II Automatic Transmission Fluid. Check for leaks and repair if necessary. If unit is still noisy after drain and refill, disassembly and inspection may be required to locate source of noise.
NOISY IN—OR JUMPS OUT OF FOUR-WHEEL-DRIVE LOW RANGE	<ul style="list-style-type: none"> (a) Transfer case not completely engaged in 4L position. (b) Shift linkage loose or binding. (c) Range fork cracked, inserts worn, or fork is binding on shift rail. (d) Annulus gear or lockplate work or damaged. 	<ul style="list-style-type: none"> (a) Stop vehicle, shift transfer case to Neutral, then shift back into 4L position. (b) Tighten, lubricate, or repair linkage as necessary. (c) Disassemble unit and repair as necessary (d) Disassemble unit and repair as necessary
LUBRICANT LEAKING FROM OUTPUT SHAFT SEALS OR FROM VENT	<ul style="list-style-type: none"> (a) Transfer case overfilled. (b) Vent closed or restricted. (c) Output shaft seals damaged or installed correctly. 	<ul style="list-style-type: none"> (a) Drain to correct level. (b) Clear or replace vent if necessary. (c) Replace seals. Be sure seal lip faces interior of case when installed. Also be sure yoke seal surfaces are not scored or nicked. Remove scores and nicks with fine sandpaper or replace yoke(s) if necessary.
ABNORMAL TIRE WEAR	<ul style="list-style-type: none"> (a) Extended operation on dry hard surface (paved) roads in 4H range. 	<ul style="list-style-type: none"> (a) Operate in 2H on hard surface (paved) roads.

REMOVAL AND INSTALLATION

TRANSFER CASE

REMOVAL

- (1) Shift transfer case into Neutral.
- (2) Raise vehicle.
- (3) Drain transfer case lubricant.
- (4) Mark front and rear propeller shaft yokes for alignment reference.
- (5) Support transmission with jack stand.
- (6) Remove rear crossmember, or skid plate.
- (7) Disconnect front/rear propeller shafts at transfer case.
- (8) Disconnect vehicle speed sensor wires.
- (9) Disconnect transfer case linkage rod from range lever.
- (10) Disconnect transfer case vent hose (Fig. 3) and indicator switch harness, if necessary.
- (11) Support transfer case with transmission jack.
- (12) Secure transfer case to jack with chains.
- (13) Remove nuts attaching transfer case to transmission.
- (14) Pull transfer case and jack rearward to disengage transfer case.
- (15) Remove transfer case from under vehicle.

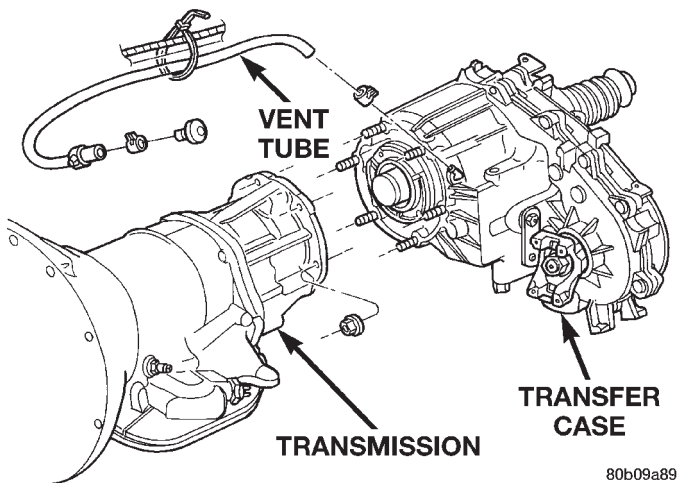


Fig. 3 Transfer Case Mounting

INSTALLATION

- (1) Mount transfer case on a transmission jack.
- (2) Secure transfer case to jack with chains.
- (3) Position transfer case under vehicle.
- (4) Align transfer case and transmission shafts and install transfer case on transmission.
- (5) Install and tighten transfer case attaching nuts to 35 N·m (26 ft. lbs.) torque (Fig. 3).
- (6) Connect vehicle speed sensor wires, and vent hose.
- (7) Connect indicator switch harness to transfer case switch, if necessary. Secure wire harness to clips on transfer case.

(8) Align and connect propeller shafts. Refer to Group 3, Differential and Driveline, for proper procedures and specifications.

(9) Fill transfer case with correct fluid. Check transmission fluid level. Correct as necessary.

(10) Install rear crossmember, or skid plate. Tighten crossmember bolts to 41 N·m (30 ft. lbs.) torque.

(11) Remove transmission jack and support stand.

(12) Connect shift rod to transfer case range lever.

(13) Adjust transfer case shift linkage.

(14) Lower vehicle and verify transfer case shift operation.

SHIFT LEVER

REMOVAL

- (1) Shift transfer case into 4L.
- (2) Raise vehicle.
- (3) Loosen adjusting trunion locknut and slide shift rod out of trunion (Fig. 4). If rod lacks enough travel to come out of trunion, push trunion out of torque shaft.
- (4) Lower vehicle.
- (5) Remove console. Refer to Group 23, Body, for proper procedures.
- (6) Remove screws attaching lever assembly to floorpan and remove assembly and shift rod (if left attached).

INSTALLATION

- (1) If shift rod was not removed from lever assembly, work rod down through floorpan opening. Then position lever assembly on floorpan and install assembly attaching screws.
- (2) Install console. Refer to Group 23, Body, for proper procedures.
- (3) Raise vehicle.
- (4) Connect trunion to torque shaft arm. Or, slide shift rod into trunion on range lever. Be sure shift rod slides freely in trunion.
- (5) Verify that range lever is in 4L position. Then tighten trunion lock bolt.
- (6) Lower vehicle and check transfer case shift operation.

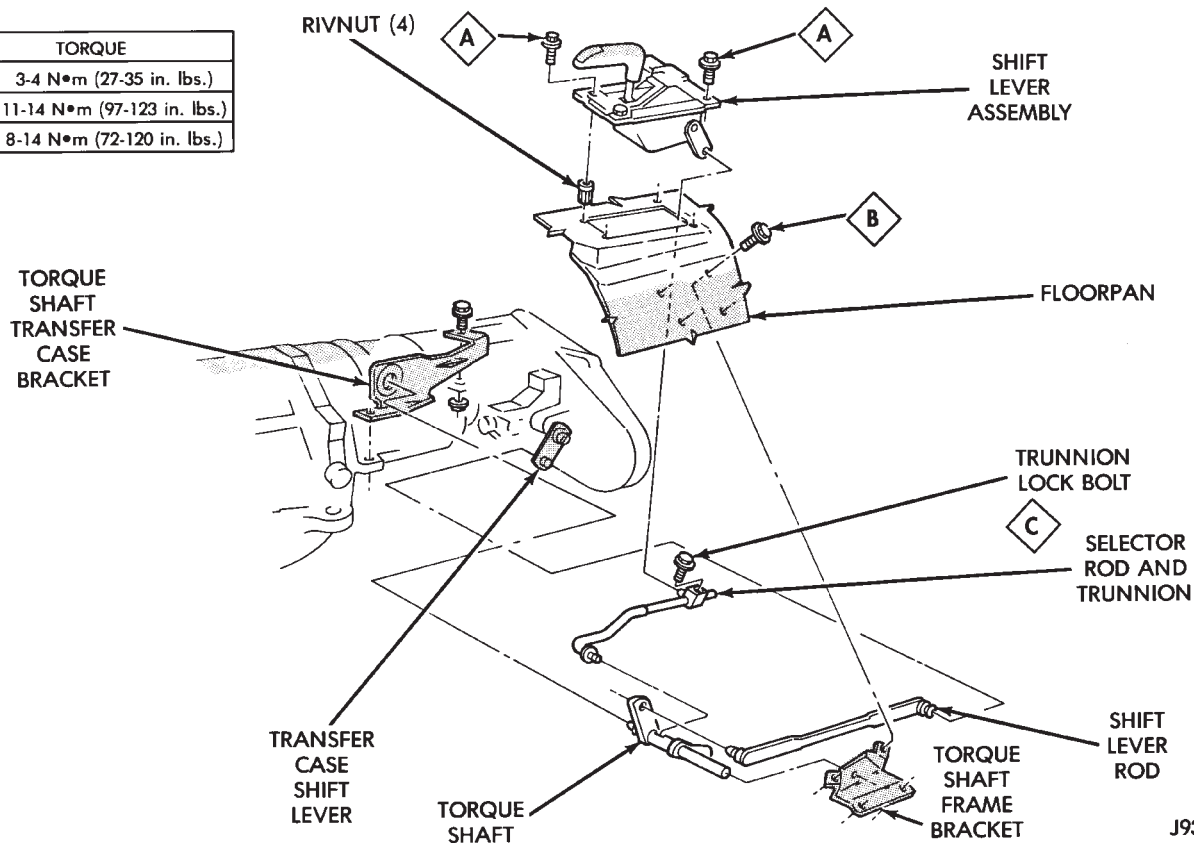
SPEEDOMETER

REMOVAL

- (1) Raise vehicle.
- (2) Disconnect wires from vehicle speed sensor.
- (3) Remove adapter clamp and screw (Fig. 5).
- (4) Remove speed sensor and speedometer adapter as an assembly.
- (5) Remove speed sensor retaining screw and remove sensor from adapter.

REMOVAL AND INSTALLATION (Continued)

TORQUE	
A	3-4 N•m (27-35 in. lbs.)
B	11-14 N•m (97-123 in. lbs.)
C	8-14 N•m (72-120 in. lbs.)



J9321-185

Fig. 4 Shift Linkage

(6) Remove speedometer pinion from adapter. Replace pinion if chipped, cracked, or worn.

(7) Inspect sensor and adapter O-rings (Fig. 5). Remove and discard O-rings if worn or damaged.

(8) Inspect terminal pins in speed sensor. Clean pins with Mopar® electrical spray cleaner if dirty or oxidized. Replace sensor if faulty, or if pins are loose, severely corroded, or damaged.

INSTALLATION AND INDEXING

(1) Thoroughly clean adapter flange and adapter mounting surface in housing. Surfaces must be clean for proper adapter alignment and speedometer operation.

(2) Install new O-rings on speed sensor and speedometer adapter (Fig. 5), if necessary.

(3) Lubricate sensor and adapter O-rings with transmission fluid.

(4) Install vehicle speed sensor in speedometer adapter. Tighten sensor attaching screw to 2-3 N•m (15-27 in. lbs.) torque.

(5) Install speedometer pinion in adapter.

(6) Count number of teeth on speedometer pinion. Do this before installing assembly in housing. Then lubricate pinion teeth with transmission fluid.

(7) Note index numbers on adapter body (Fig. 6). These numbers will correspond to number of teeth on pinion.

(8) Install speedometer assembly in housing.

(9) Rotate adapter until required range numbers are at 6 o'clock position. Be sure range index numbers correspond to number of teeth on pinion gear.

(10) Install speedometer adapter clamp and retaining screw. Tighten clamp screw to 10-12 N•m (90-110 in. lbs.) torque.

(11) Connect wires to vehicle speed sensor.

(12) Lower vehicle and top off transmission fluid level if necessary.

FRONT OUTPUT SHAFT SEAL**REMOVAL**

- (1) Raise vehicle.
- (2) Remove front propeller shaft. Refer to Group 3, Differential and Driveline, for proper procedure.
- (3) Remove front output shaft yoke.
- (4) Remove seal from front case with pry tool (Fig. 7).

INSTALLATION

(1) Install new front output seal in front case with Installer Tool 6952-A as follows:

REMOVAL AND INSTALLATION (Continued)

ITEM	TORQUE
A	2-3 N•m (15-27 in. lbs.)
B	10-12 N•m (90-110 in. lbs.)

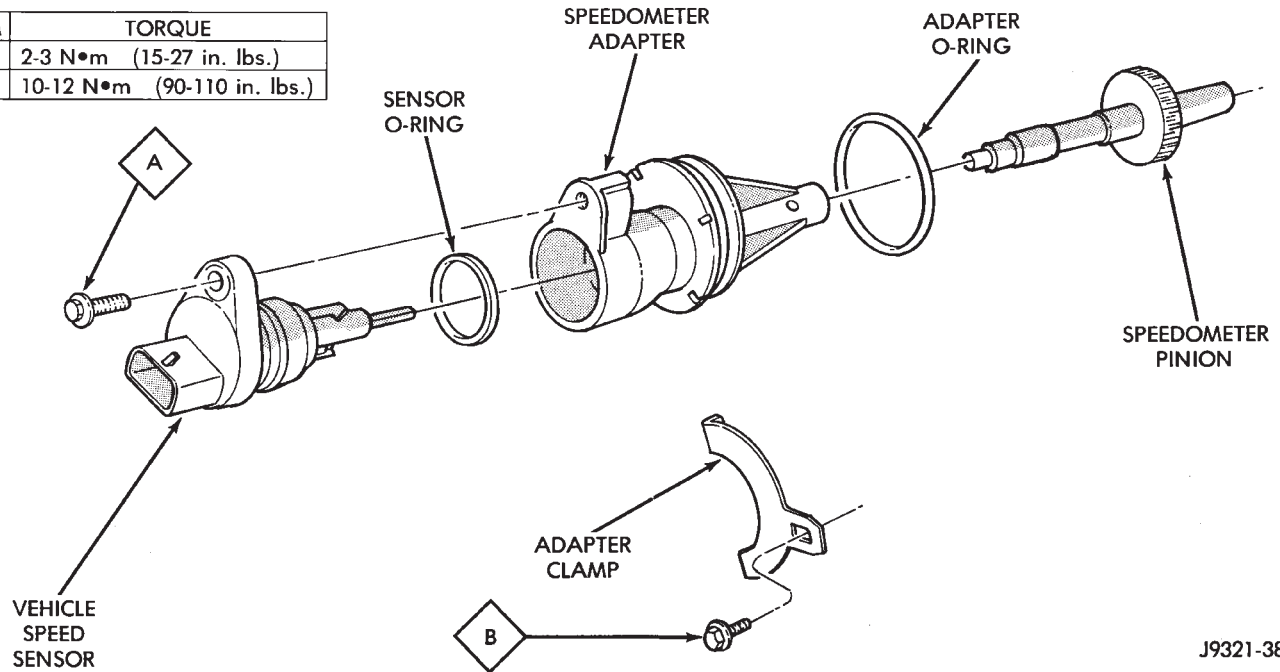


Fig. 5 Speedometer Components

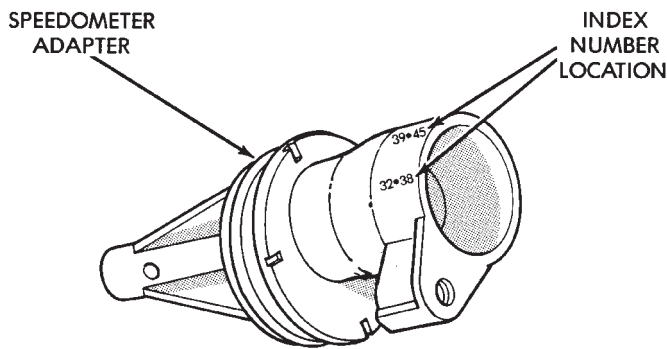


Fig. 6 Location Of Index Numbers On Speedometer Adapter

- (a) Place new seal on tool. Garter spring on seal goes toward interior of case.
- (b) Start seal in bore with light taps from hammer (Fig. 8). Once seal is started, continue tapping seal into bore until installer tool seats against case.

REAR RETAINER BUSHING AND SEAL

REMOVAL

- (1) Raise vehicle.
- (2) Remove rear propeller shaft. Refer to Group 3, Differential and Driveline, for proper procedure.
- (3) Using a suitable pry tool or slide-hammer mounted screw, remove the rear retainer seal.

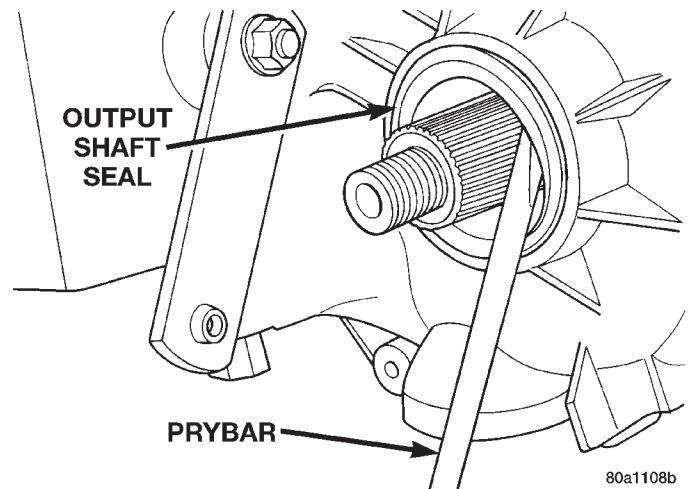


Fig. 7 Remove Front Output Shaft Seal

- (4) Using Remover 6957, remove bushing from rear retainer (Fig. 9).

INSTALLATION

- (1) Clean fluid residue from sealing surface and inspect for defects.
- (2) Position replacement bushing in rear retainer with fluid port in bushing aligned with slot in retainer.
- (3) Using Installer 8145, drive bushing into retainer until installer seats against case (Fig. 10).
- (4) Using Installer C-3995-A, install seal in rear retainer (Fig. 11).
- (5) Install propeller shaft.
- (6) Verify proper fluid level.
- (7) Lower vehicle.

REMOVAL AND INSTALLATION (Continued)

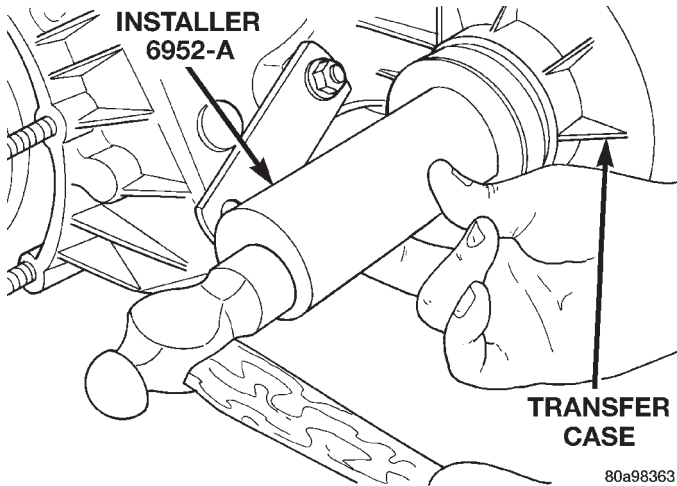


Fig. 8 Front Output Seal Installation

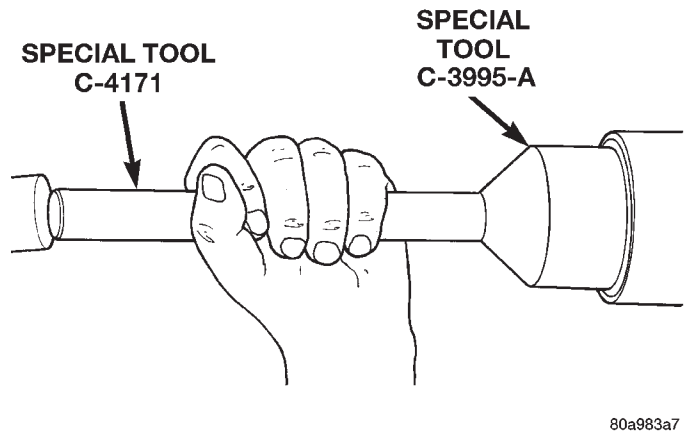


Fig. 11 Install Rear Retainer Seal

DISASSEMBLY AND ASSEMBLY

NV249 TRANSFER CASE

DISASSEMBLY

Position transfer case on shallow drain pan. Remove drain plug and drain lubricant remaining in case.

REAR RETAINER AND OIL PUMP REMOVAL

- (1) Remove the speedometer adapter.
- (2) Remove rear retainer bolts (Fig. 12).
- (3) Remove rear bearing locating ring access cover screws, cover and gasket (Fig. 13).

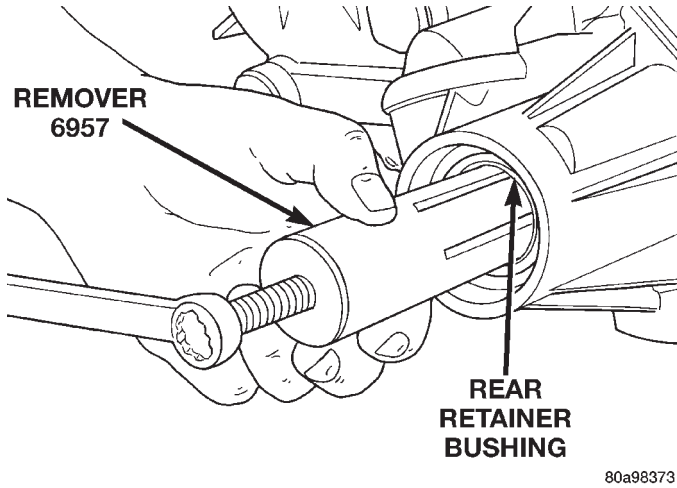


Fig. 9 Rear Retainer Bushing Removal

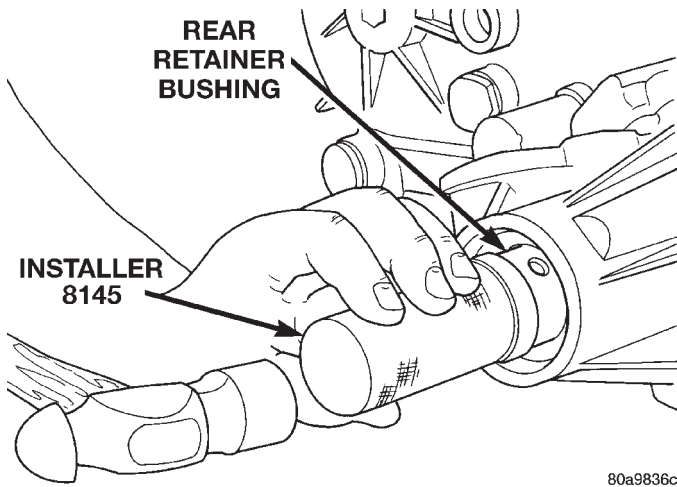


Fig. 10 Rear Retainer Bushing Install

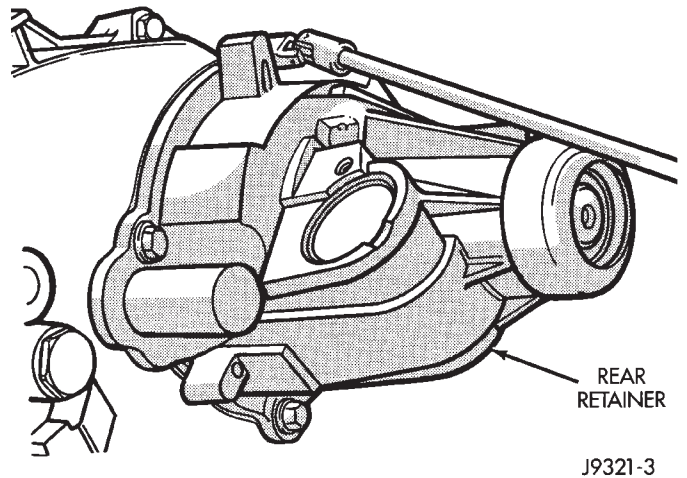


Fig. 12 Rear Retainer Bolt Removal

DISASSEMBLY AND ASSEMBLY (Continued)

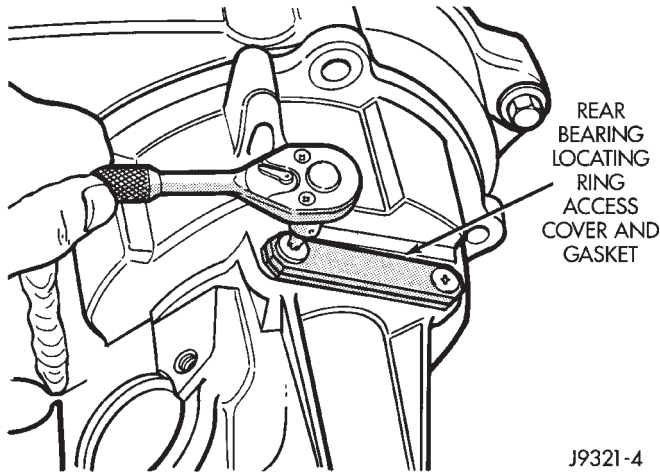


Fig. 13 Locating Ring Access Cover And Gasket Removal

(4) Loosen rear retainer with pry tool to break sealer bead. Pry only against retainer boss as shown (Fig. 14).

(5) Remove rear retainer as follows:

(a) Spread rear bearing locating ring with snap ring pliers (Fig. 15).

(b) Then slide retainer off mainshaft and rear bearing (Fig. 16).

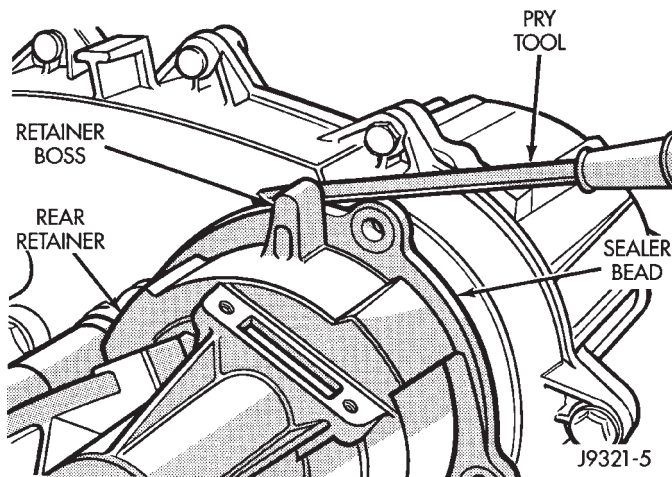


Fig. 14 Loosening Rear Retainer

(6) Remove speedometer drive gear (Fig. 17).

(7) Remove rear bearing snap-ring.

(8) Remove rear bearing. Note position of bearing locating ring groove for assembly reference.

(9) Disengage oil pickup tube from oil pump and remove oil pump assembly (Fig. 18).

(10) Remove pick-up tube o-ring from oil pump (Fig. 19), if necessary. Do not disassemble the oil pump, it is not serviceable.

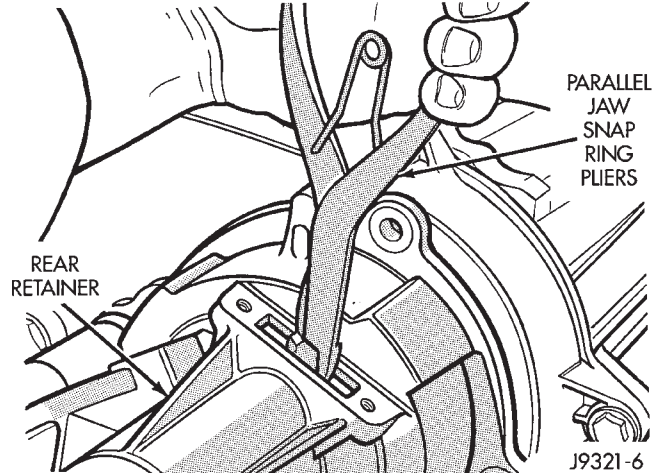


Fig. 15 Disengaging Rear Bearing Locating Ring

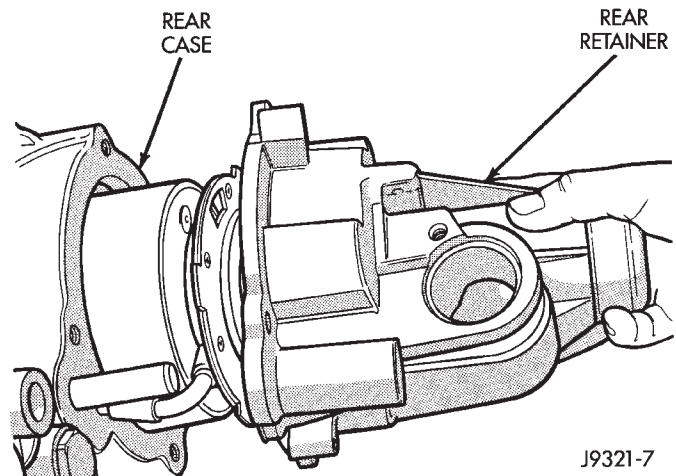


Fig. 16 Rear Retainer Removal

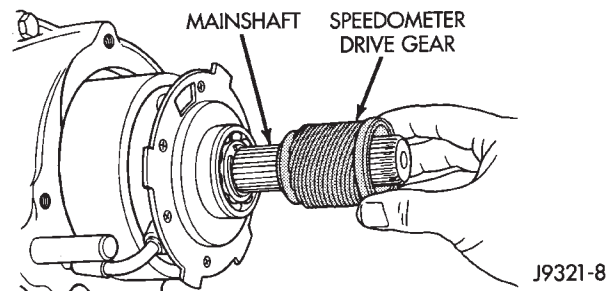


Fig. 17 Speedometer Drive Gear Removal

VISCOUS COUPLER REMOVAL

(1) Remove oil pump locating snap-ring and viscous coupling snap-ring from mainshaft (Fig. 20).

(2) Remove viscous coupling from mainshaft (Fig. 20).

YOKE AND RANGE LEVER REMOVAL

(1) Remove transfer case indicator switch.

(2) Remove front yoke nut as follows:

(a) Move range lever to 4L position.

DISASSEMBLY AND ASSEMBLY (Continued)

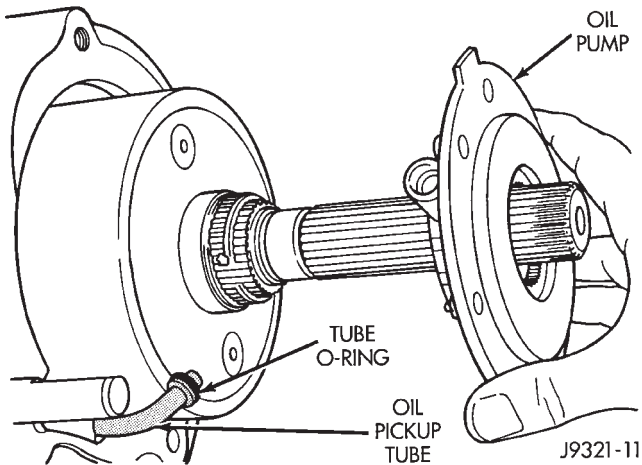


Fig. 18 Rear Bearing and Oil Pump Removal

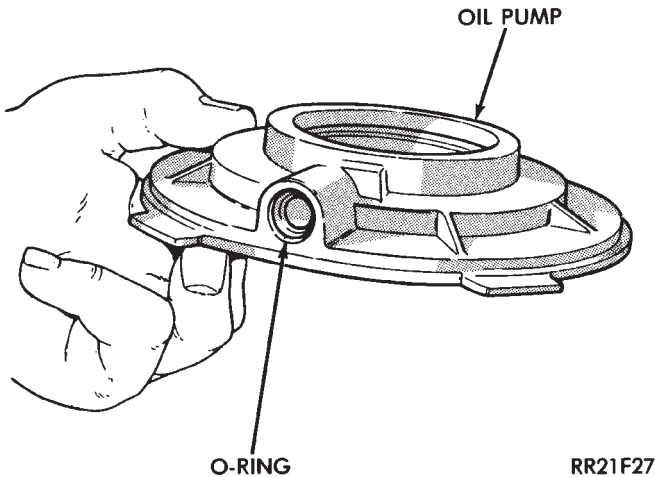


Fig. 19 Pick-up Tube O-ring Location

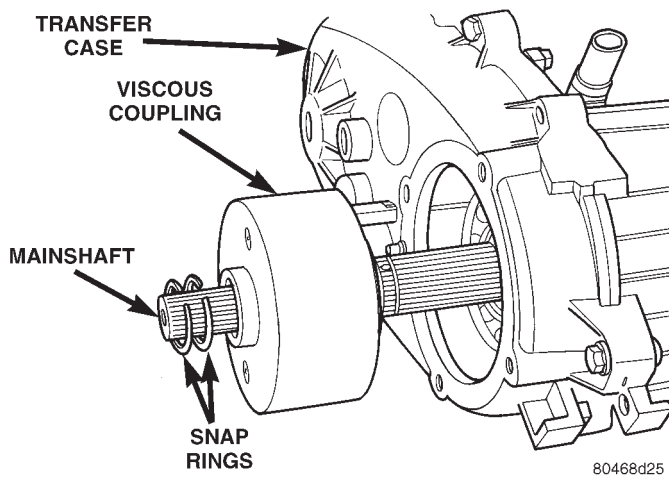


Fig. 20 Viscous Coupling Removal

- (b) Remove nut with socket and impact wrench (Fig. 21).
- (3) Remove yoke. If yoke is difficult to remove by hand, remove it with bearing splitter, or with stan-

ard two jaw puller (Fig. 22). Be sure puller tool is positioned on yoke and not on slinger as slinger will be damaged.

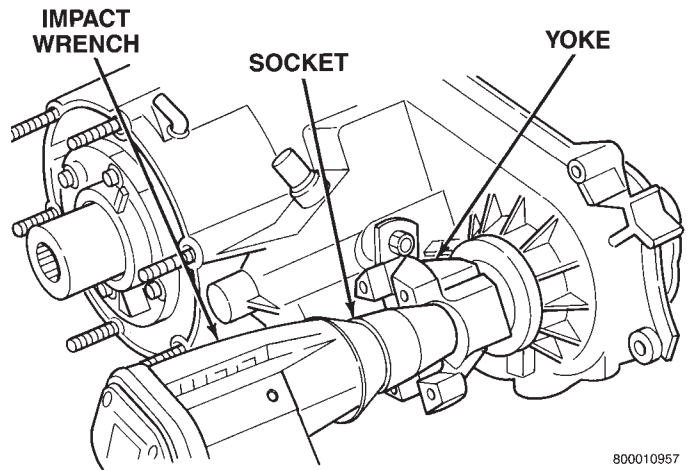


Fig. 21 Yoke Nut Removal

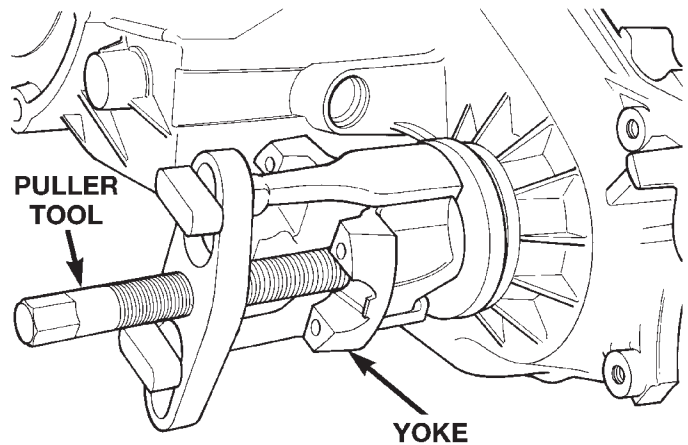


Fig. 22 Yoke Removal

- (4) Remove seal washer from front output shaft. Discard washer as it should not be reused.
- (5) Remove nut and washer that attach range lever to sector shaft. Then move sector to neutral position and remove range lever from shaft (Fig. 23).

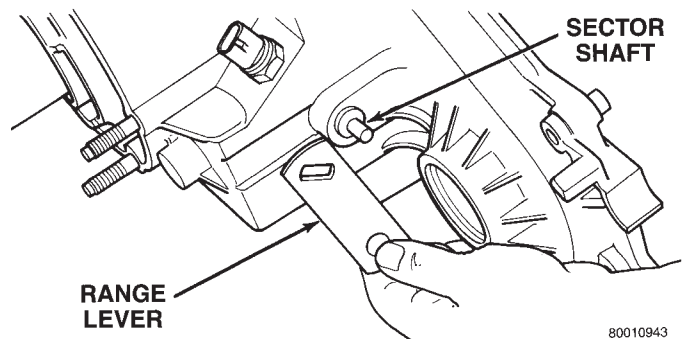


Fig. 23 Range Lever Removal

DISASSEMBLY AND ASSEMBLY (Continued)

FRONT OUTPUT SHAFT AND DRIVE CHAIN REMOVAL

- (1) Support transfer case so rear case is facing upward.
- (2) Remove bolts holding front case to rear case. The case alignment bolt require flat washers (Fig. 24).
- (3) Loosen rear case with flat blade screwdriver to break sealer bead. Insert screwdriver blade only into notches provided at each end of case (Fig. 25).
- (4) Remove rear case (Fig. 26).

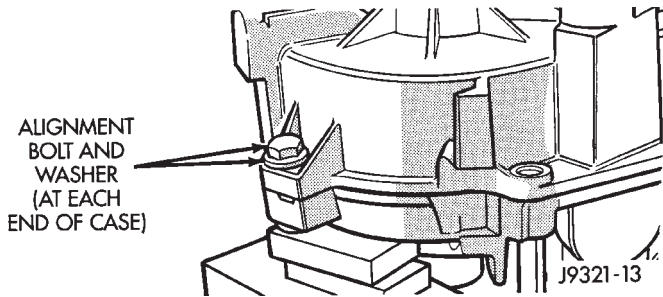


Fig. 24 Rear Case Alignment Bolt Locations

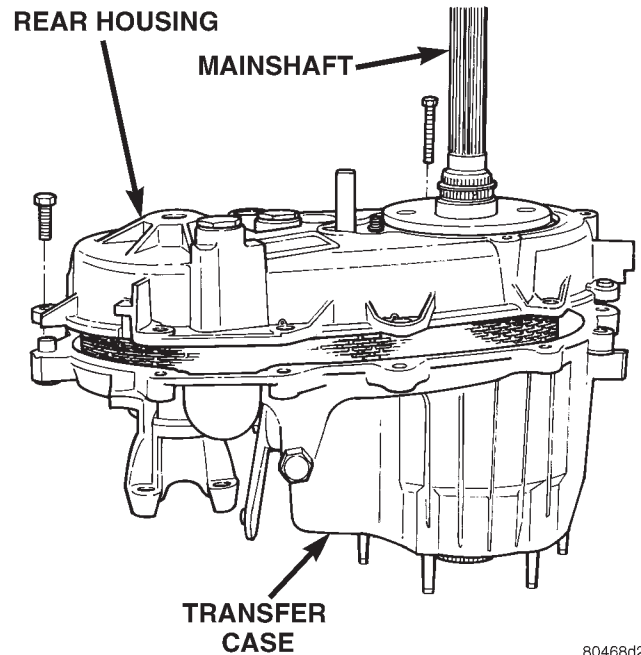


Fig. 26 Rear Case Removal

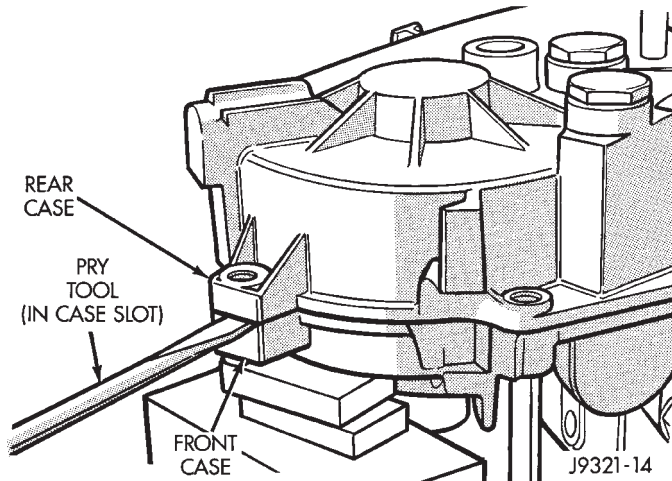


Fig. 25 Loosening Rear Case

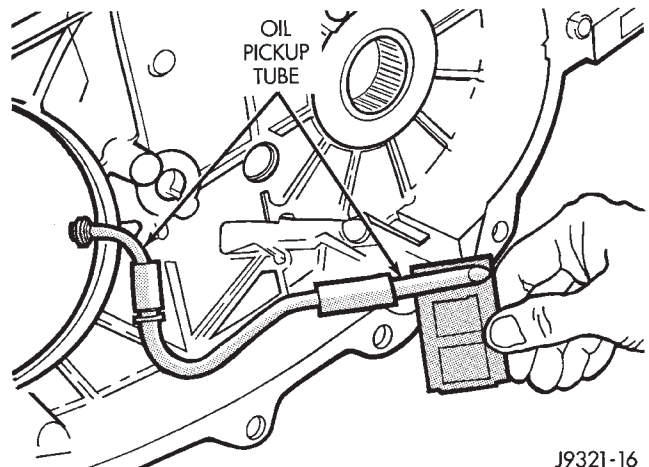


Fig. 27 Oil Pickup Tube Removal

- (5) Remove oil pickup tube from rear case (Fig. 27).
- (6) Remove drive gear snap-ring (Fig. 28).
- (7) Disengage drive gear (Fig. 28). Pry gear upward and off mainshaft as shown.
- (8) Remove front output shaft, drive chain and drive gear as assembly (Fig. 28).

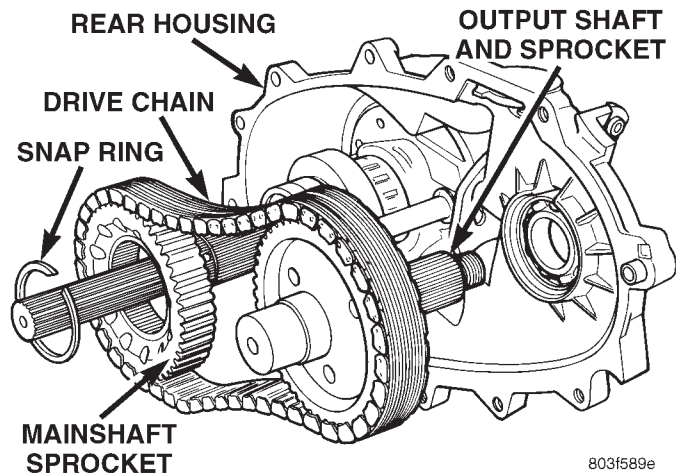
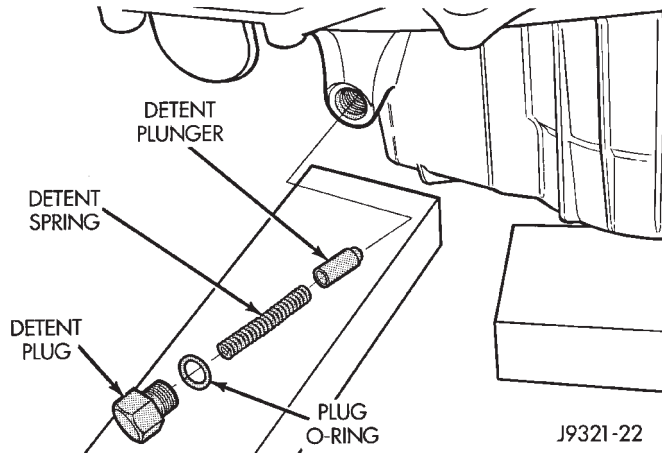


Fig. 28 Front Output Shaft, Drive Gear And Chain Removal

DISASSEMBLY AND ASSEMBLY (Continued)

SHIFT FORKS AND MAINSHAFT REMOVAL

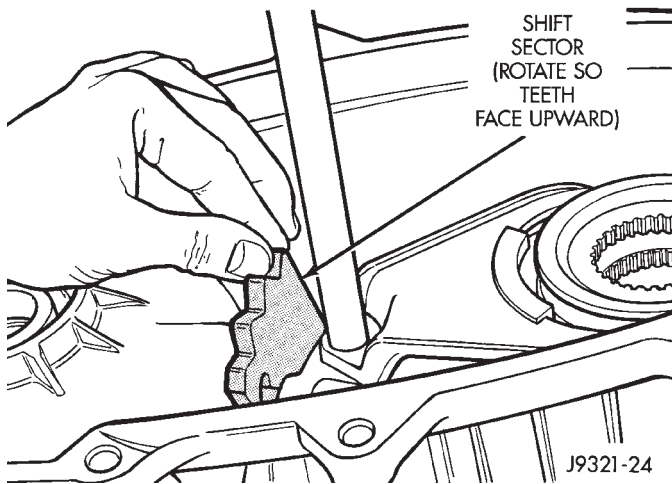
- (1) Remove detent plug, O-ring, detent spring and detent plunger (Fig. 29).
- (2) Remove mainshaft from clutch sleeve and input gear pilot bearing.



J9321-22

Fig. 29 Detent Plug, Spring And Plunger Removal

- (3) Rotate shift sector so sector teeth face upward (Fig. 30).
- (4) Remove range fork, rail and clutch sleeve as assembly (Fig. 31). Lift shift rail upward, rotate fork out of shift sector and remove assembly.



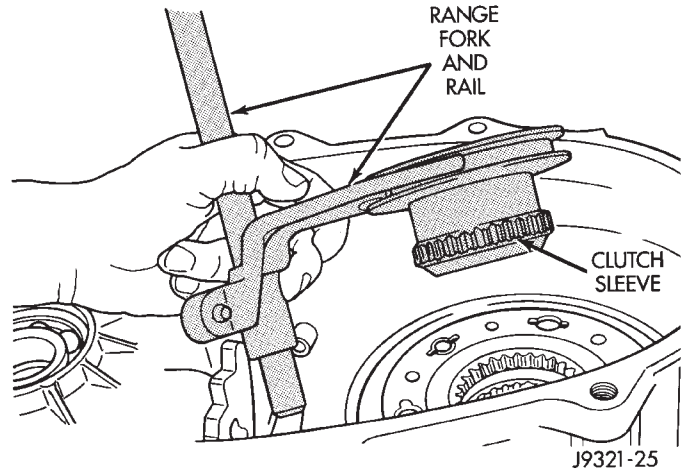
J9321-24

Fig. 30 Rotating Shift Sector

- (5) Remove shift sector. Rotate and tilt sector as needed to remove it (Fig. 32).
- (6) Remove shift sector bushing and O-ring (Fig. 33).

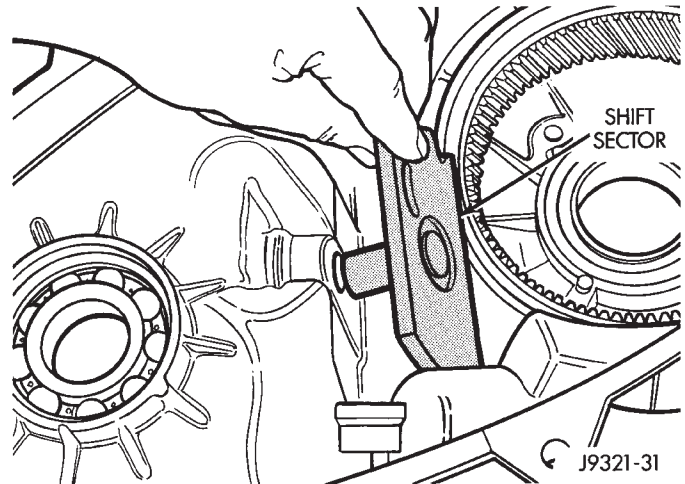
INPUT GEAR/LOW RANGE ASSEMBLY REMOVAL

- (1) Turn front case on side so front bearing retainer is accessible.
- (2) Remove front bearing retainer bolts (Fig. 34).
- (3) Remove front bearing retainer as follows:



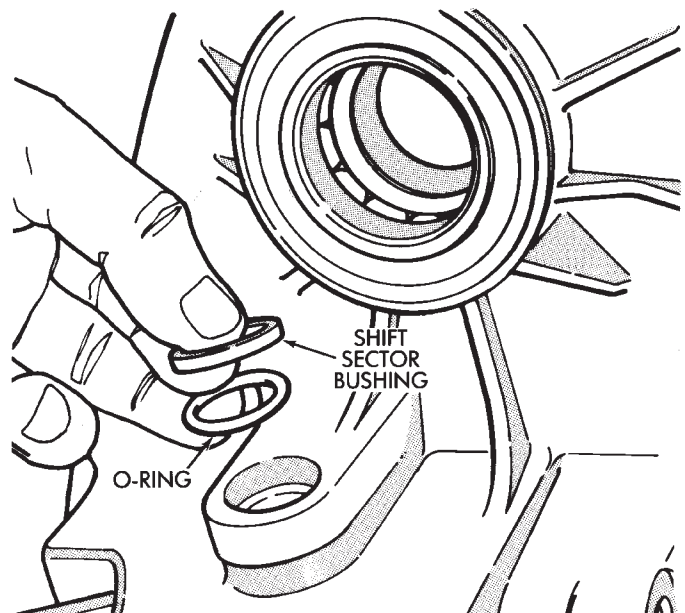
J9321-25

Fig. 31 Range Fork And Clutch Sleeve Removal



J9321-31

Fig. 32 Shift Sector Removal



J8921-207

Fig. 33 Sector Bushing And O-Ring Removal

DISASSEMBLY AND ASSEMBLY (Continued)

(a) Loosen retainer with flat blade screwdriver to break sealer bead. **To avoid damaging case and retainer, position screwdriver blade only in slots provided in retainer (Fig. 35).**

(b) Then remove retainer from case and gear.

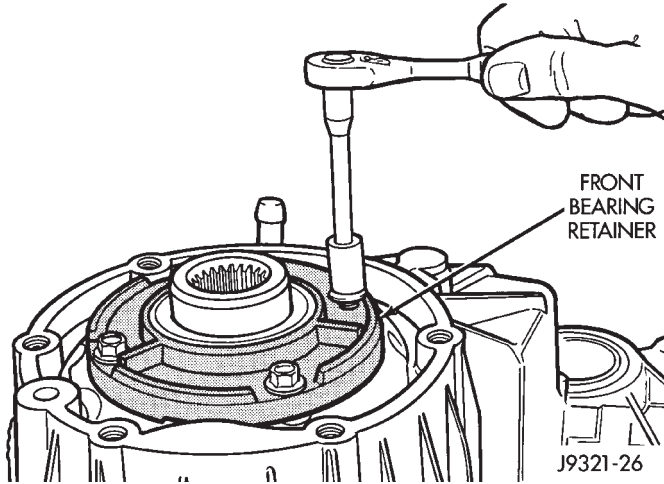


Fig. 34 Front Bearing Retainer Bolt Removal

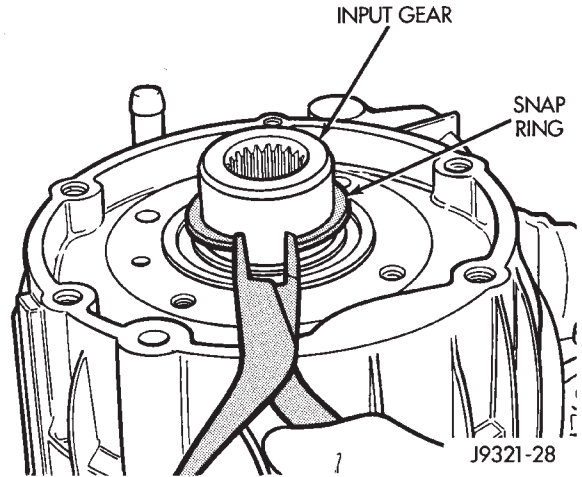


Fig. 36 Input Gear Snap-Ring Removal

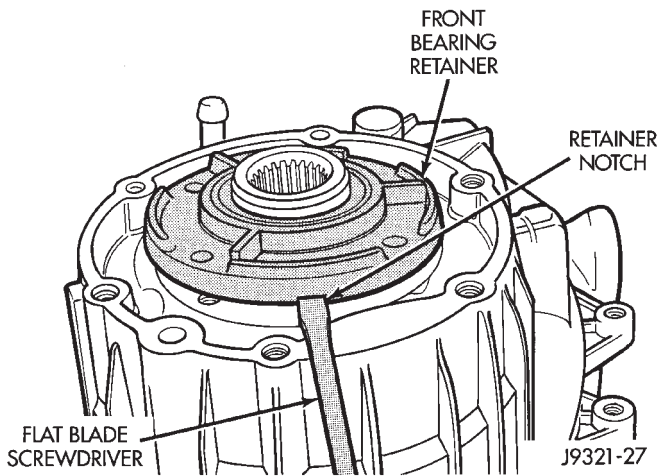


Fig. 35 Front Bearing Retainer Removal

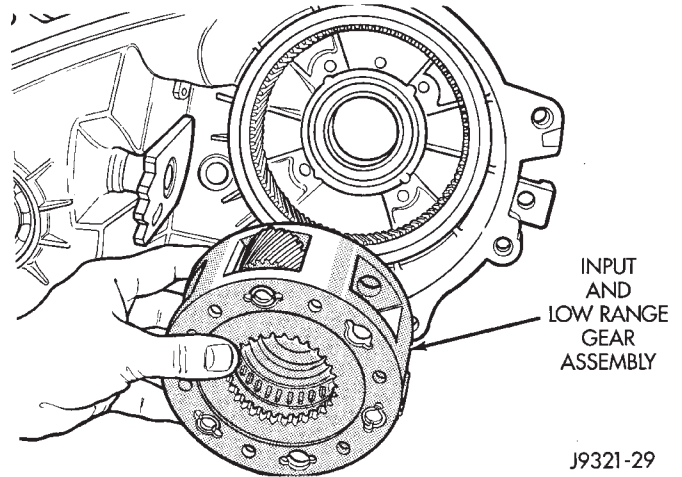


Fig. 37 Input And Low Range Gear Assembly Removal

(4) Remove snap-ring that retains input gear shaft in front bearing (Fig. 36).

(5) Remove input and low range gear assembly (Fig. 37).

(6) Remove oil seals from following components:

- front bearing retainer.
- rear retainer.
- case halves.

INPUT AND LOW RANGE GEAR DISASSEMBLY

(1) Remove snap-ring that retains input gear in low range gear (Fig. 38).

(2) Remove retainer (Fig. 39).

(3) Remove front tabbed thrust washer (Fig. 40).

(4) Remove input gear (Fig. 41).

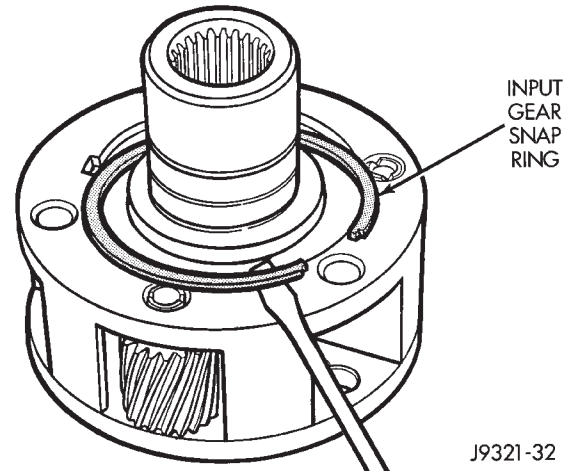


Fig. 38 Input Gear Snap-Ring Removal

DISASSEMBLY AND ASSEMBLY (Continued)

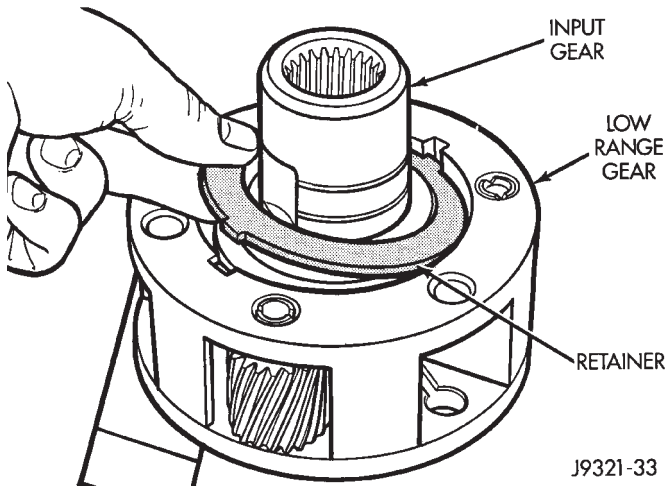


Fig. 39 Input Gear Retainer Removal

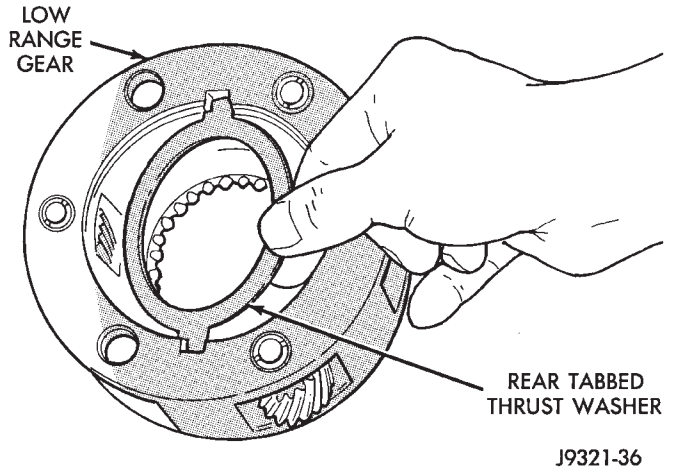


Fig. 42 Rear Tabbed Thrust Washer Removal

CAUTION: The bearing bores in various transfer case components contain oil feed holes. Make sure replacement bearings do not block the holes.

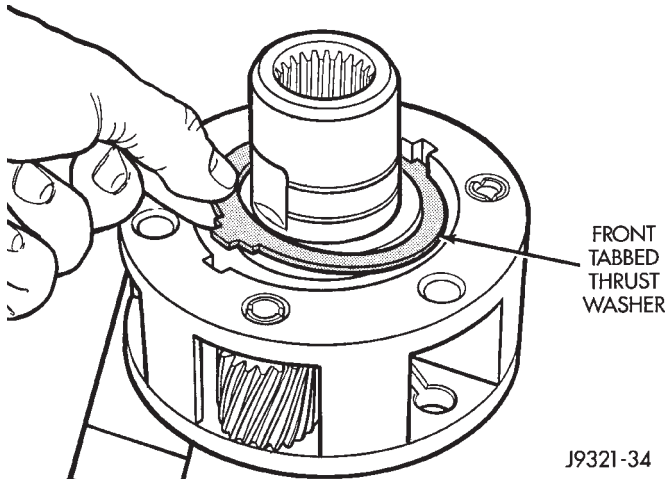


Fig. 40 Front Tabbed Thrust Washer Removal

BEARING AND SEAL INSTALLATION

(1) Remove front output shaft seal from front case with pry tool (Fig. 43).

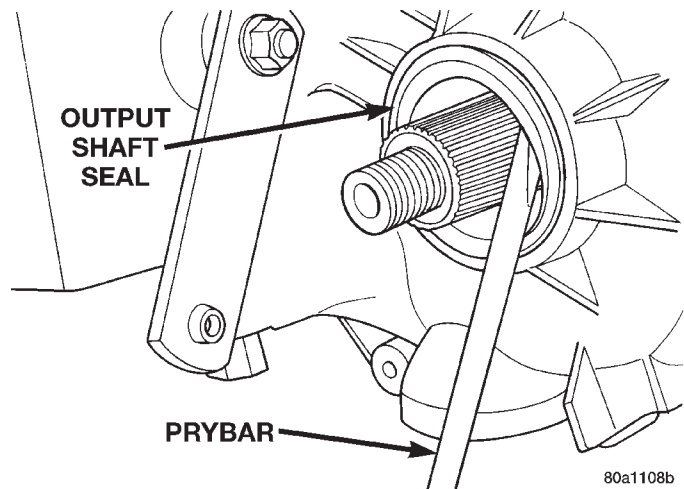


Fig. 43 Remove Front Output Shaft Seal

- (2) Remove snap-ring that retains front output shaft bearing in front case (Fig. 44).
- (3) Using tool 6953, remove bearing from front case (Fig. 45).
- (4) Using tool 6953, install new bearing.
- (5) Install snap-ring to hold bearing into case.
- (6) Install new front output seal in front case with Installer Tool 6952-A as follows:

(a) Place new seal on tool. **Garter spring on seal goes toward interior of case.**

(b) Start seal in bore with light taps from hammer (Fig. 46). Once seal is started, continue tap-

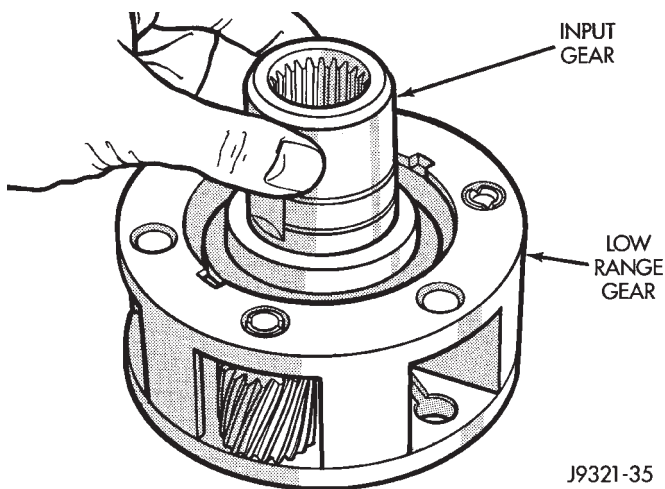


Fig. 41 Input Gear Removal

ASSEMBLY

Lubricate transfer case components with Mopar® Dexron II automatic transmission fluid or petroleum jelly (where indicated) during assembly.

DISASSEMBLY AND ASSEMBLY (Continued)

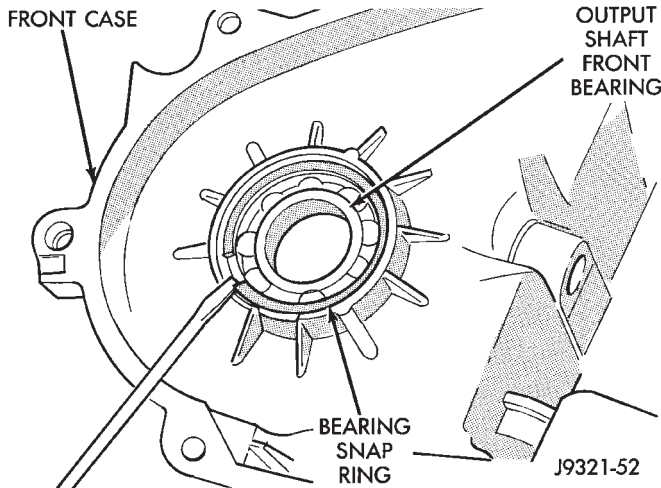


Fig. 44 Output Shaft Front Bearing Snap-Ring Removal

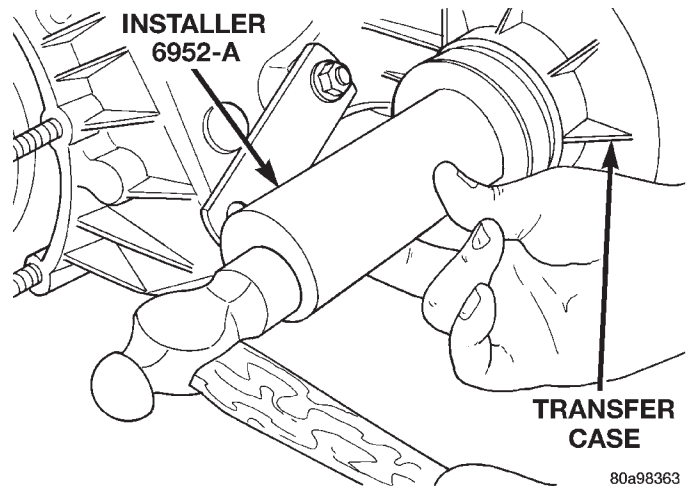


Fig. 46 Front Output Seal Installation

(7) Remove the output shaft rear bearing with the screw and jaws from Remover L-4454 and Cup 8148 (Fig. 47).

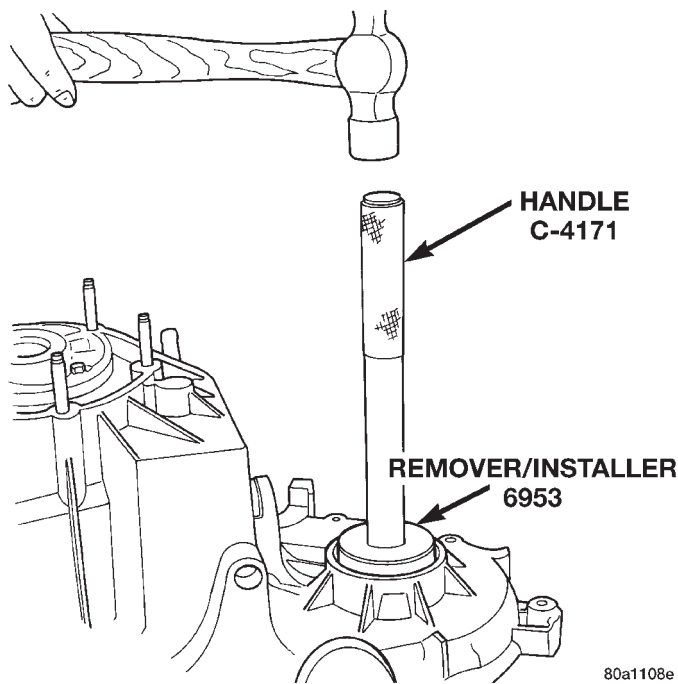


Fig. 45 Remove Output Shaft Front Bearing

ping seal into bore until installer tool bottoms against case.

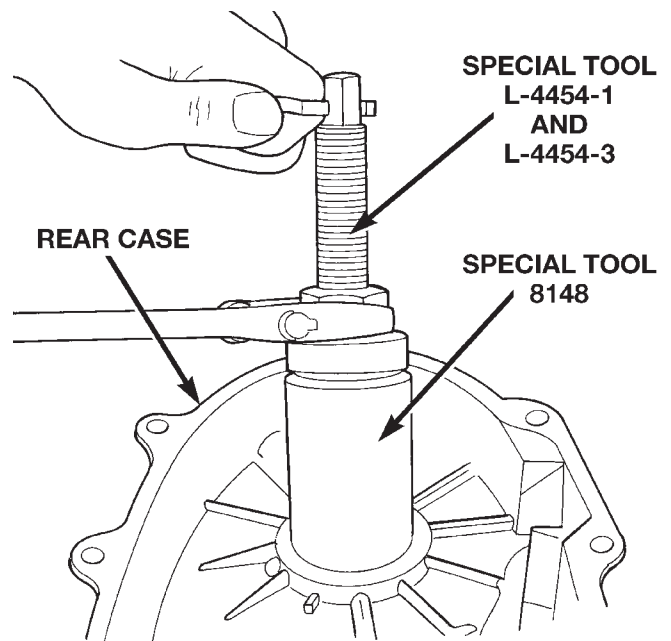


Fig. 47 Output Shaft Rear Bearing Removal

DISASSEMBLY AND ASSEMBLY (Continued)

(8) Install new bearing with Tool Handle C-4171 and Installer 5066 (Fig. 48). **The bearing bore is chamfered at the top. Install the bearing so it is flush with the lower edge of this chamfer (Fig. 49).**

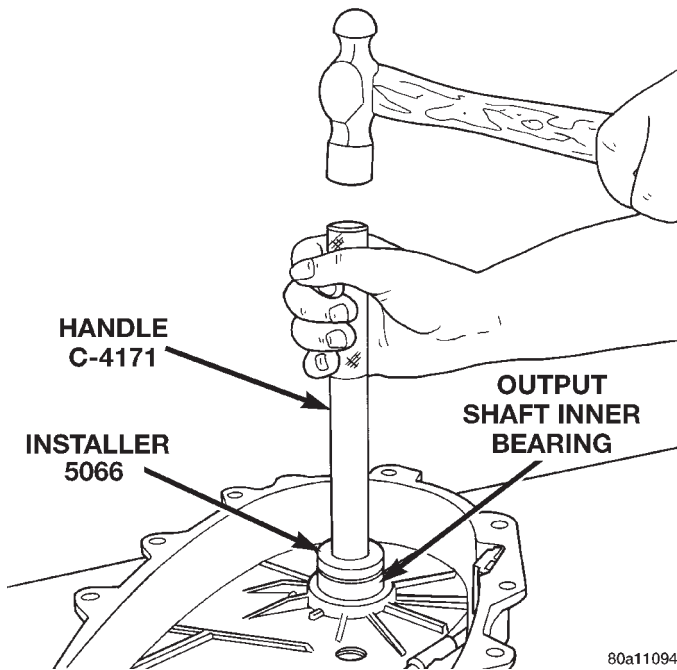


Fig. 48 Output Shaft Rear Bearing Installation

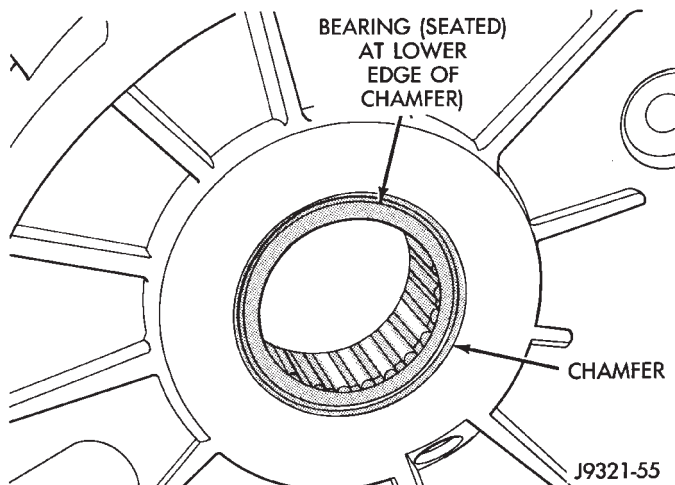


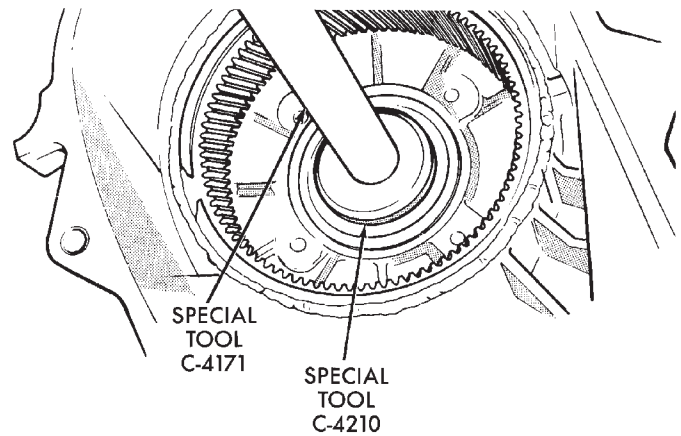
Fig. 49 Output Shaft Rear Bearing Installation Depth

(9) Using Remover C-4210 and Handle C-4171, drive input shaft bearing from inside the annulus gear opening in the case. (Fig. 50).

(10) Install locating ring on new bearing.

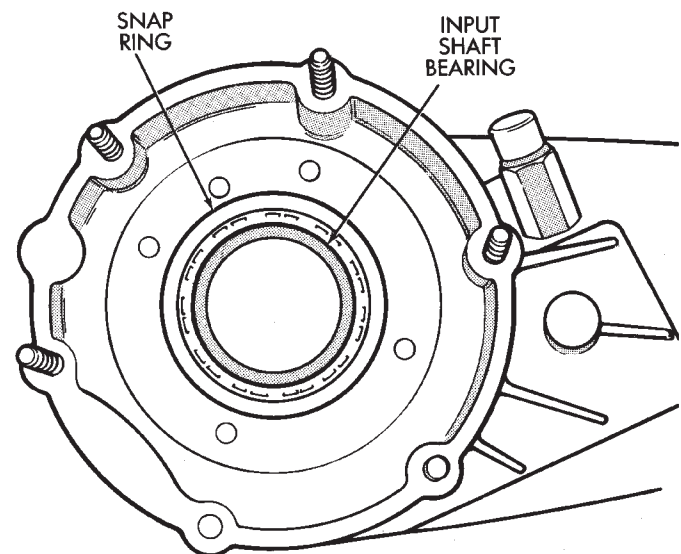
(11) Position case so forward end is facing upward.

(12) Using Remover C-4210 and Handle C-4171, drive input shaft bearing into case. The bearing locating ring must be fully seated against case surface (Fig. 51).



J9521-43

Fig. 50 Input Shaft Bearing Removal



J8921-219

Fig. 51 Seating Input Shaft Bearing

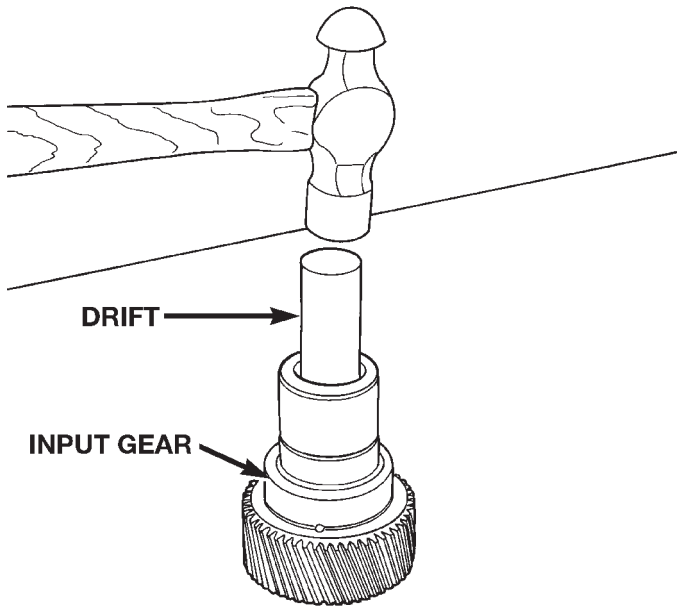
(13) Remove input gear pilot bearing by inserting a suitably sized drift into the splined end of the input gear and driving the bearing out with the drift and a hammer (Fig. 52).

(14) Install new pilot bearing with Installer 8128 and Handle C-4171 (Fig. 53).

(15) Remove front bearing retainer seal with suitable pry tool.

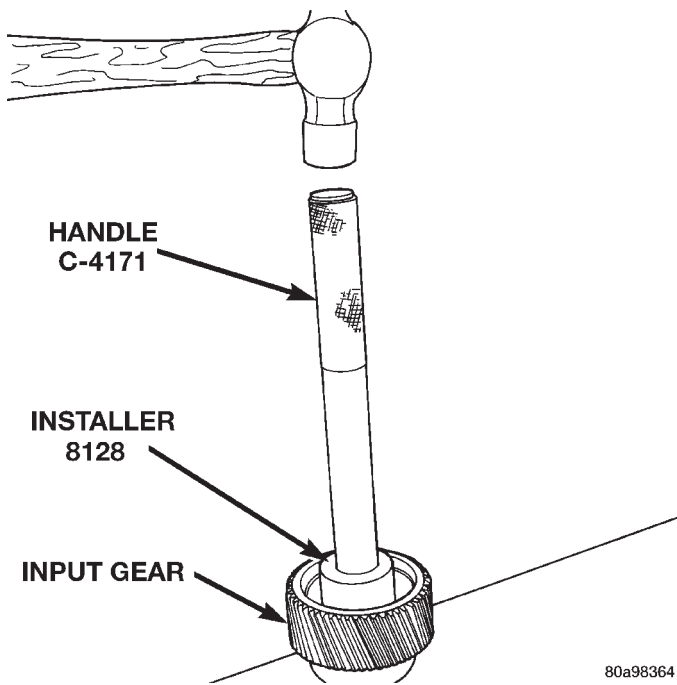
(16) Install new front bearing retainer with Installer 7884 (Fig. 54).

DISASSEMBLY AND ASSEMBLY (Continued)



80a11090

Fig. 52 Remove Input Gear Pilot Bearing



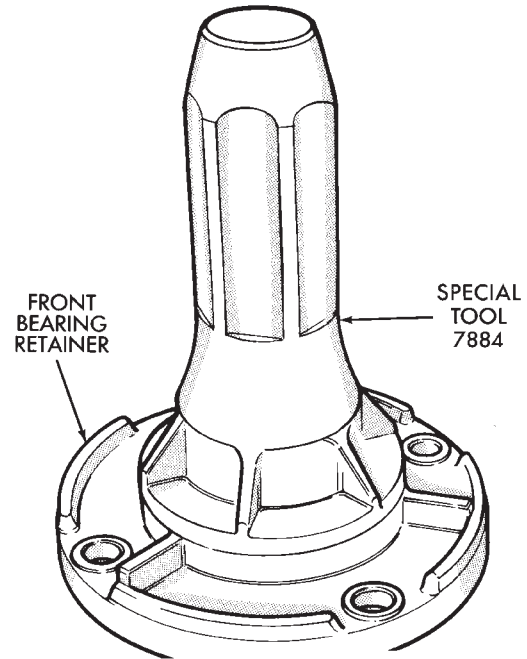
80a98364

Fig. 53 Install Input Gear Pilot Bearing

INPUT AND LOW RANGE GEAR ASSEMBLY

(1) Lubricate gears and thrust washers (Fig. 55) with recommended transmission fluid.

(2) Install first thrust washer in low range gear (Fig. 55). Be sure washer tabs are properly aligned in gear notches.



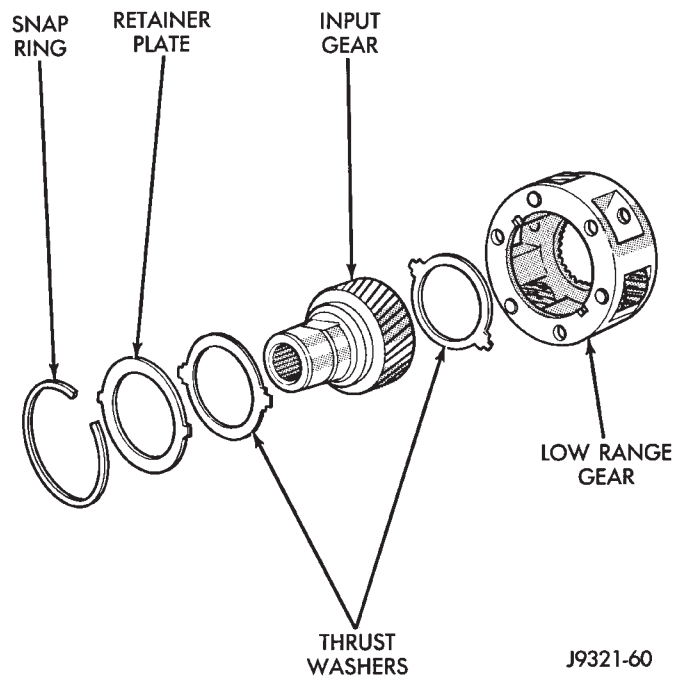
J9521-41

Fig. 54 Install Front Bearing Retainer Seal

(3) Install input gear in low range gear. Be sure input gear is fully seated.

(4) Install remaining thrust washer in low range gear and on top of input gear. Be sure washer tabs are properly aligned in gear notches.

(5) Install retainer on input gear and install snapping.



J9321-60

Fig. 55 Input/Low Range Gear Components

DISASSEMBLY AND ASSEMBLY (Continued)**INPUT GEAR/LOW RANGE INSTALLATION**

(1) Align and install low range/input gear assembly in front case (Fig. 56). Be sure low range gear pinions are engaged in annulus gear and that input gear shaft is fully seated in front bearing.

(2) Install snap-ring to hold input/low range gear into front bearing (Fig. 57).

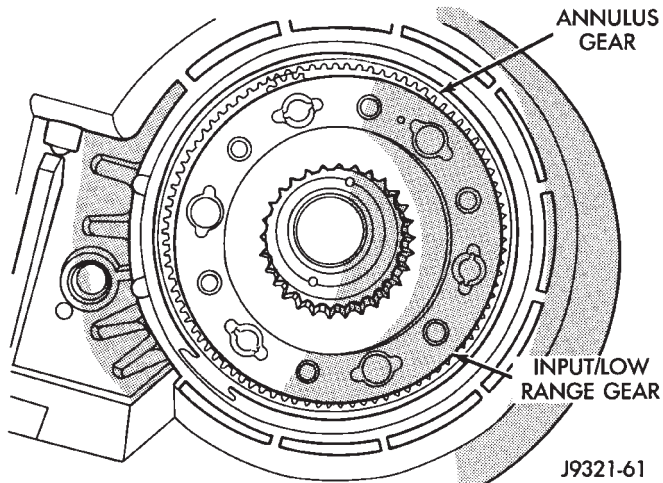


Fig. 56 Input/Low Range Gear Installation

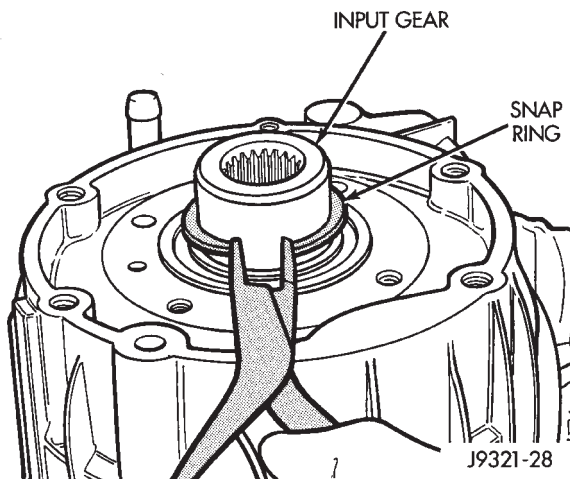


Fig. 57 Install Snap-Ring

(3) Clean gasket sealer residue from retainer and inspect retainer for cracks or other damage.

(4) Apply a 3 mm (1/8 in.) bead of Mopar® gasket maker or silicone adhesive to sealing surface of retainer.

(5) Align cavity in seal retainer with fluid return hole in front of case.

CAUTION: Do not block fluid return cavity on sealing surface of retainer when applying Mopar® gasket maker or silicone adhesive sealer. Seal failure and fluid leak can result.

(6) Install bolts to hold retainer to transfer case (Fig. 58). Tighten to 21 N·m (16 ft. lbs.) of torque.

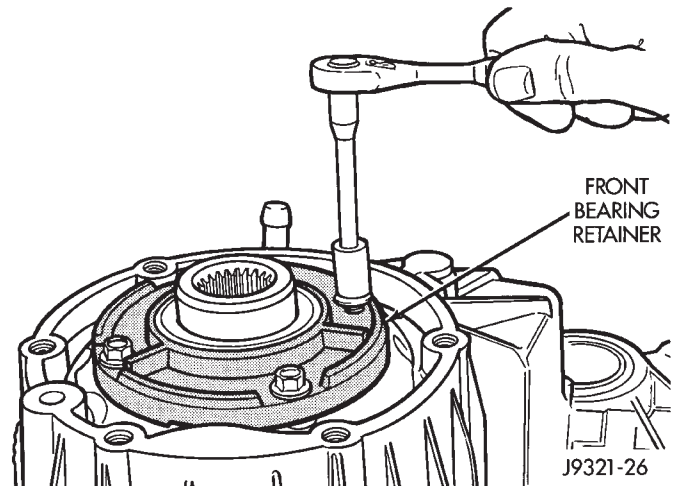


Fig. 58 Install Front Bearing Retainer

SHIFT FORKS AND MAINSHAFT INSTALLATION

(1) Install new sector shaft O-ring and bushing (Fig. 59).

(2) Install shift sector (Fig. 60).

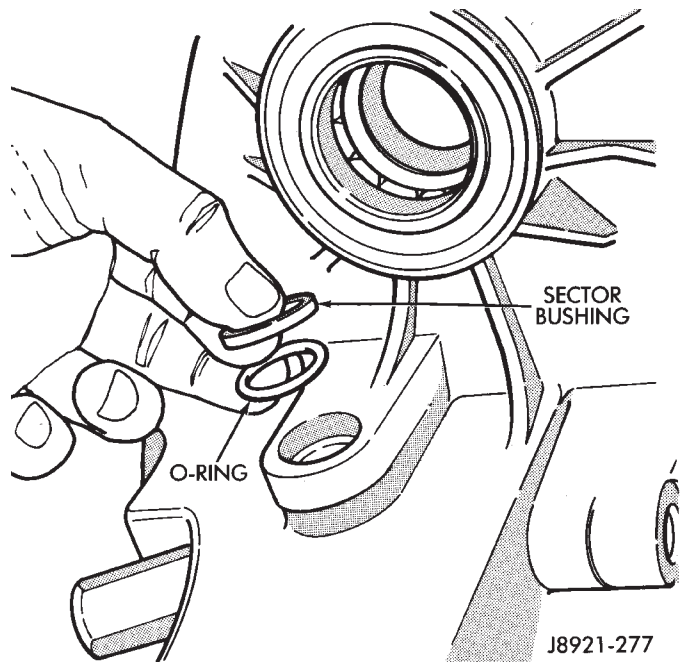


Fig. 59 Sector O-Ring And Bushing Installation

(3) Install new pads on range fork (Fig. 61), if necessary.

(4) Install clutch sleeve in range fork (Fig. 61).

(5) Install assembled range fork and clutch sleeve (Fig. 62).

(6) Insert range fork pin in sector. Then rotate sector and seat clutch gear in low range gear.

DISASSEMBLY AND ASSEMBLY (Continued)

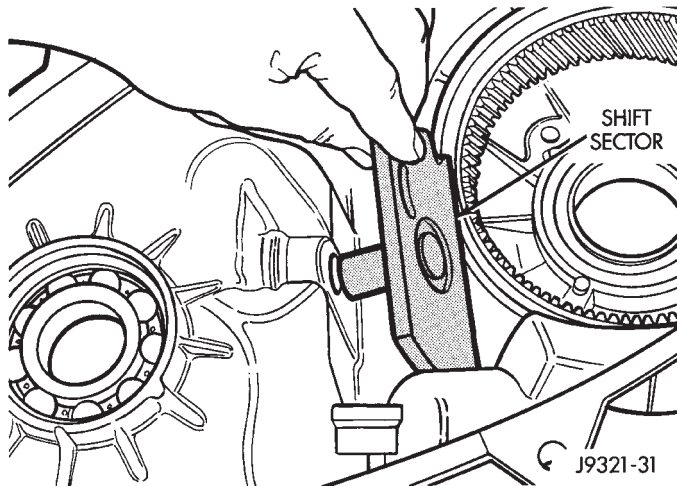


Fig. 60 Shift Sector Installation

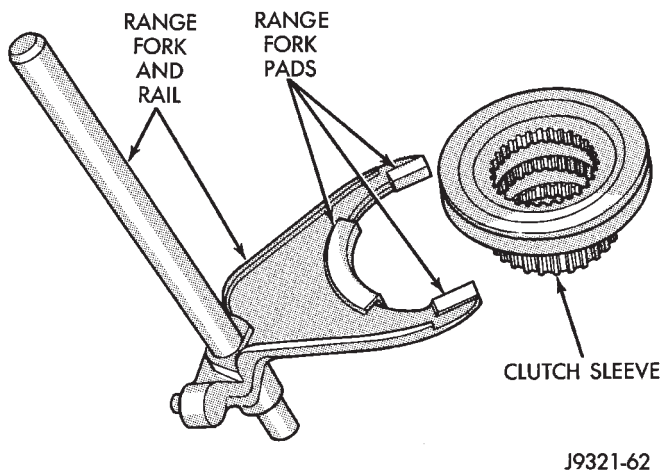


Fig. 61 Assembling Range Fork And Clutch Sleeve

- (7) Verify that range fork rail is seated in case bushing and that clutch sleeve is properly engaged in low range gear.
- (8) Rotate sector to Neutral position.

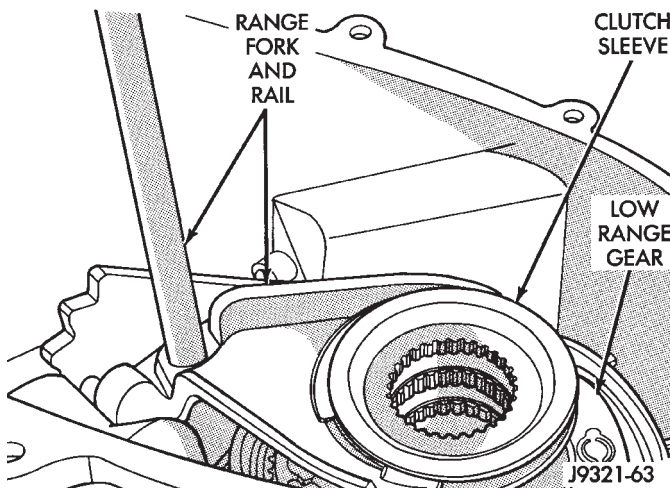


Fig. 62 Range Fork And Clutch Sleeve Installation

- (9) Install new O-ring on detent plug (Fig. 63).
- (10) Lubricate detent plunger with transmission fluid or light coat of petroleum jelly.
- (11) Install detent plunger, spring and plug (Fig. 63).
- (12) Verify that plunger is properly engaged in sector.

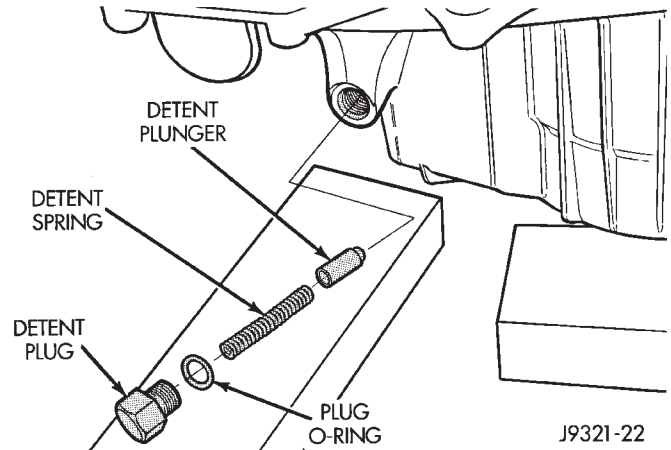


Fig. 63 Shift Detent Components

- (13) Insert mainshaft into input gear pilot bearing.

FRONT OUTPUT SHAFT AND DRIVE CHAIN INSTALLATION

- (1) Lubricate front output shaft-sprocket assembly, drive chain and drive sprocket with transmission fluid.
- (2) Assemble drive chain, drive sprocket and front output shaft (Fig. 64).
- (3) Start drive sprocket on mainshaft.

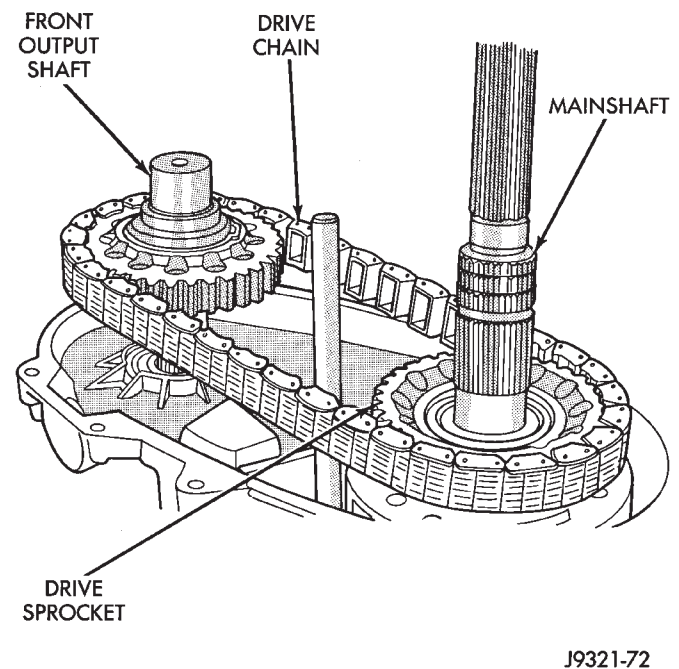


Fig. 64 Installing Drive Chain, Front Output Shaft And Drive Sprocket

DISASSEMBLY AND ASSEMBLY (Continued)

- (4) Guide front shaft into bearing and drive sprocket onto mainshaft drive gear (Fig. 64).
- (5) Install drive sprocket snap-ring (Fig. 65).

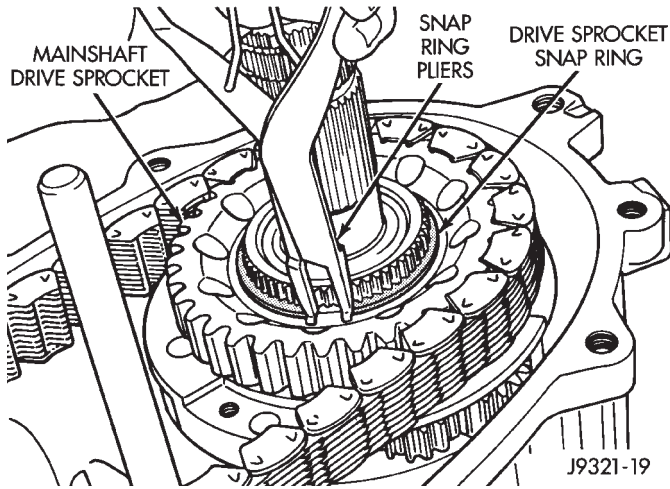


Fig. 65 Installing Drive Sprocket Snap-Ring

- (6) Clean sealing flanges of front case and rear case with a wax and grease remover.
- (7) Apply 3 mm (1/8 in.) wide bead of Mopar® gasket maker or silicone adhesive sealer to mounting flange of front case. Work sealer bead around bolt holes as shown (Fig. 66).
- (8) Install oil pickup tube in rear case. Be sure tube is seated in case notch as shown (Fig. 67).
- (9) Install magnet in front case pocket (Fig. 68).
- (10) Align and install rear case on front case (Fig. 69).

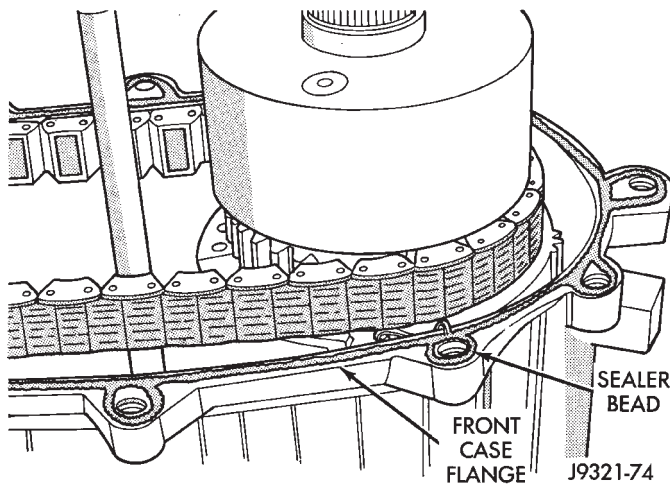


Fig. 66 Applying Sealer To Front Case Flange

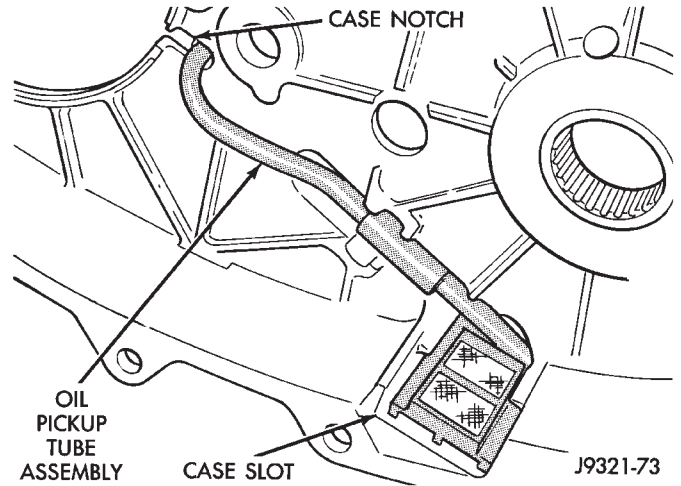


Fig. 67 Oil Pickup Tube Installation

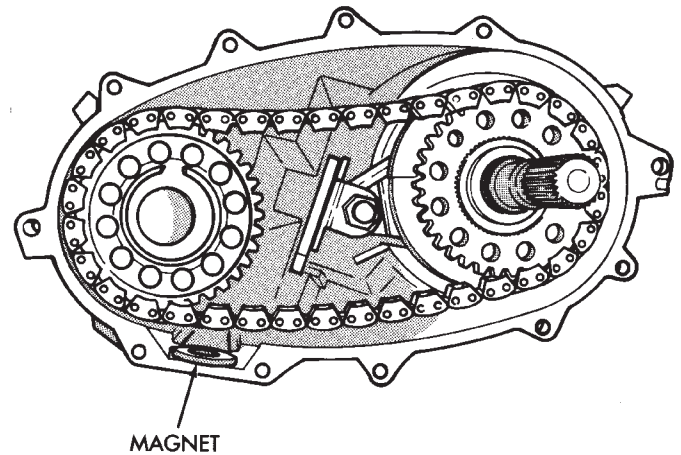


Fig. 68 Installing Case Magnet

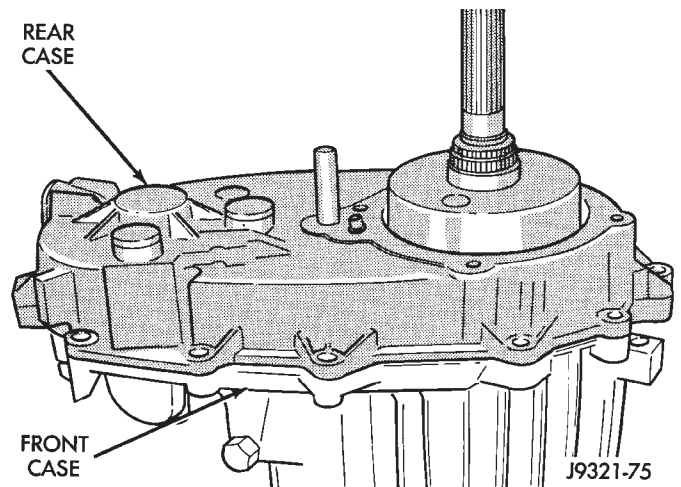


Fig. 69 Rear Case Installation

DISASSEMBLY AND ASSEMBLY (Continued)

(11) Verify that oil pickup tube is still seated in case notch and tube end is pointed toward mainshaft (Fig. 70).

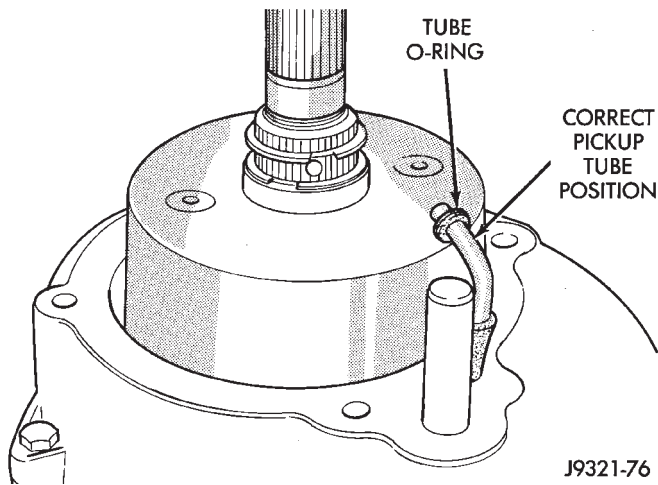


Fig. 70 Checking Position Of Oil Pickup Tube

(12) Install case attaching bolts. Alignment bolts at each end of case are only ones requiring washers (Fig. 71).

(13) Tighten case bolts to 27-34 N·m (20-25 ft. lbs.) torque.

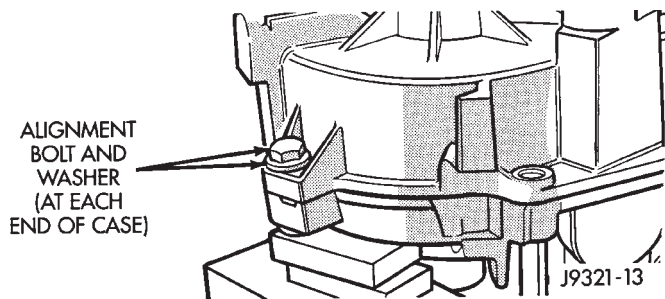


Fig. 71 Alignment Bolt Location

YOKE AND RANGE LEVER INSTALLATION

(1) Install indicator switch in front case. Tighten switch to 20-34 N·m (15-25 ft. lbs.) torque.

(2) Install range lever, washer and locknut on sector shaft (Fig. 72). Tighten locknut to 27-34 N·m (20-25 ft. lbs.) torque.

(3) Install new seal washer on front output shaft (Fig. 74).

(4) Lubricate yoke hub with transmission fluid and install yoke on front shaft.

(5) Install new seal washer on front shaft.

(6) Install yoke and new yoke nut on front output shaft (Fig. 73).

(7) Tighten yoke nut to 122-176 N·m (90-130 ft. lbs.) torque. Use Tool C-3281, or similar tool to hold yoke while tightening yoke nut.

VISCOUS COUPLER

(1) Install coupling on mainshaft (Fig. 75).

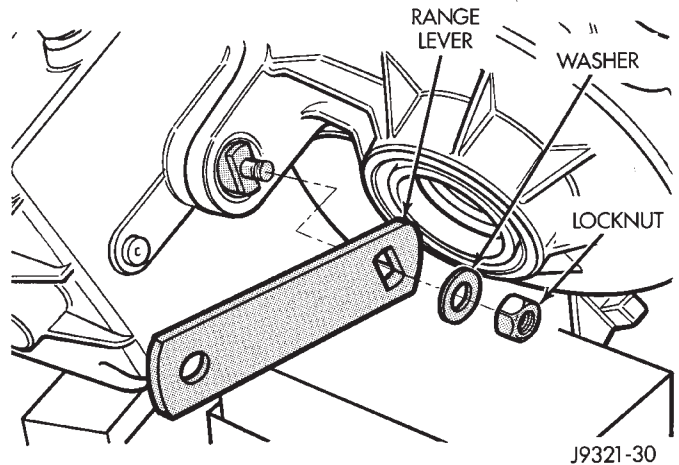


Fig. 72 Range Lever Installation

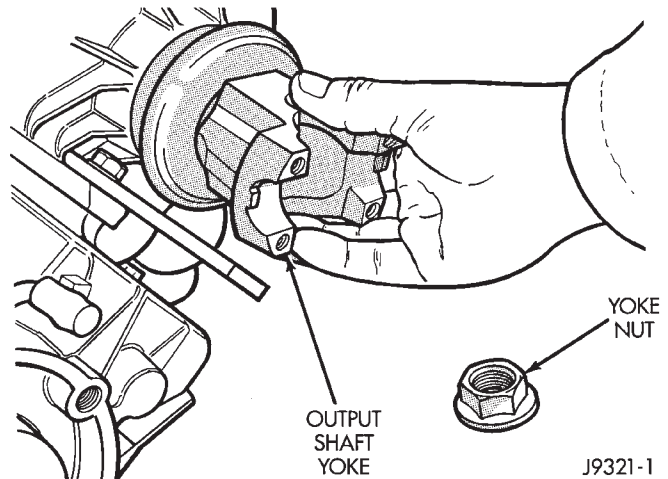


Fig. 73 Output Shaft Yoke Installation

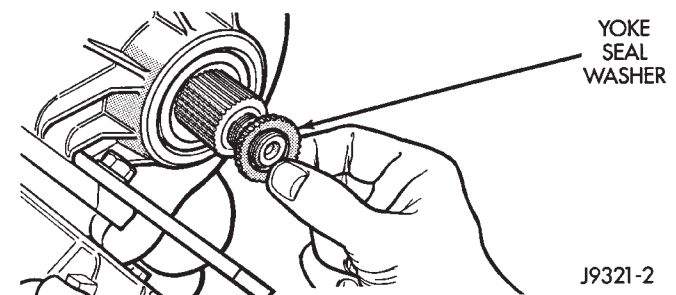


Fig. 74 Yoke Seal Washer Installation

(2) Install coupling retaining snap-ring first (Fig. 75). Be sure snap ring is fully seated before proceeding.

(3) Install oil pump locating snap-ring on mainshaft (Fig. 75).

REAR RETAINER AND OIL PUMP INSTALLATION

(1) Install new O-ring on flanged end of oil pickup tube.

(2) Install oil pump (Fig. 76).

DISASSEMBLY AND ASSEMBLY (Continued)

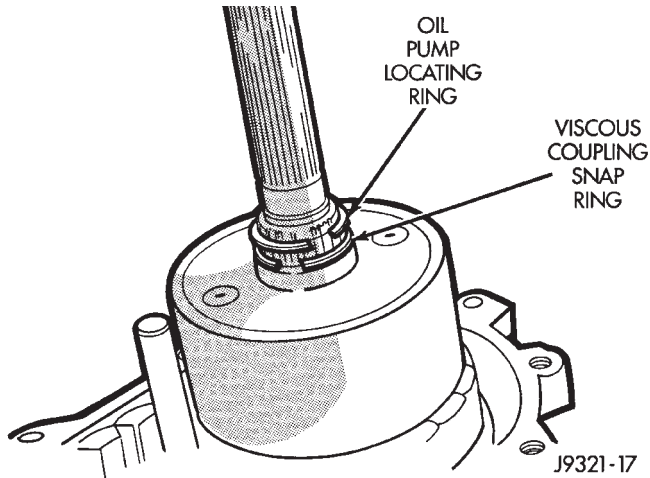


Fig. 75 Viscous Coupling And Oil Pump Snap-Ring Installation

- (3) Insert oil pickup tube in pump (Fig. 77).
- (4) Install rear bearing on mainshaft (Fig. 77). Locating ring groove in bearing goes toward end of mainshaft.
- (5) Install rear bearing retaining snap-ring (Fig. 78).
- (6) Install speedometer drive gear (Fig. 79).
- (7) Install rear bearing locating ring in rear retainer, if ring was removed during overhaul.

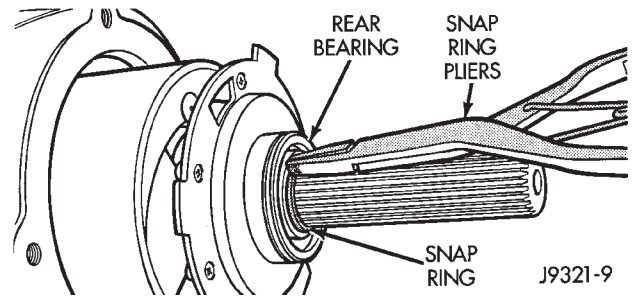


Fig. 78 Rear Bearing Snap-Ring Installation

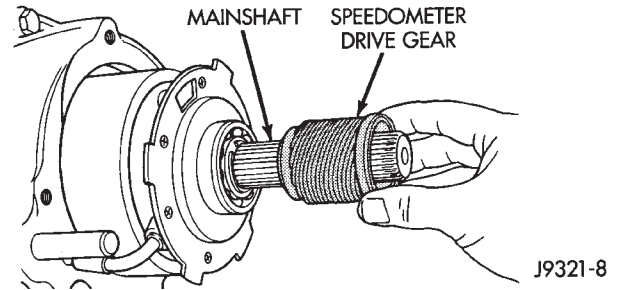


Fig. 79 Speedometer Drive Gear Installation

- (8) Apply 3 mm (1/8 in.) wide bead of Mopar® gasket maker or silicone adhesive sealer to mounting surface of rear retainer. Allow sealer to set-up slightly before proceeding.
- (9) Slide rear retainer onto mainshaft (Fig. 80).
- (10) Spread rear bearing locating ring and slide rear retainer into place on rear case (Fig. 81).
- (11) Install and tighten rear retainer bolts to 27-34 N·m (20-25 ft. lbs.).
- (12) Install locating ring access cover and gasket (Fig. 82). Tighten plate attaching screws to 10 N·m (85 in. lbs.) torque.

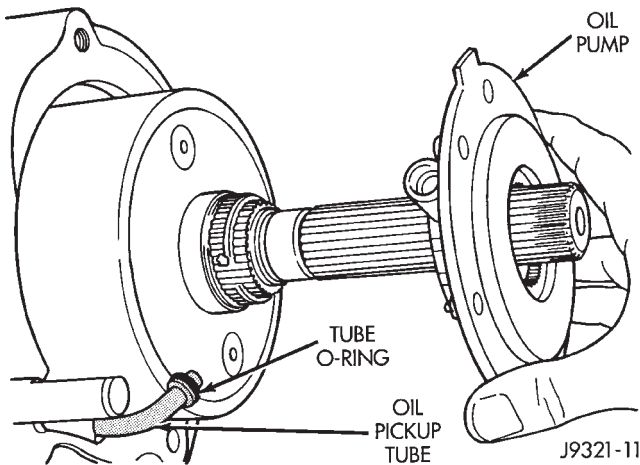


Fig. 76 Installing Oil Pump

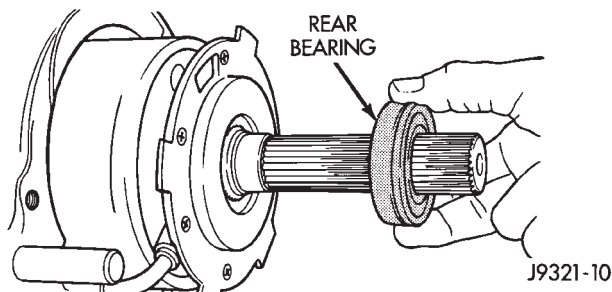


Fig. 77 Rear Bearing Installation

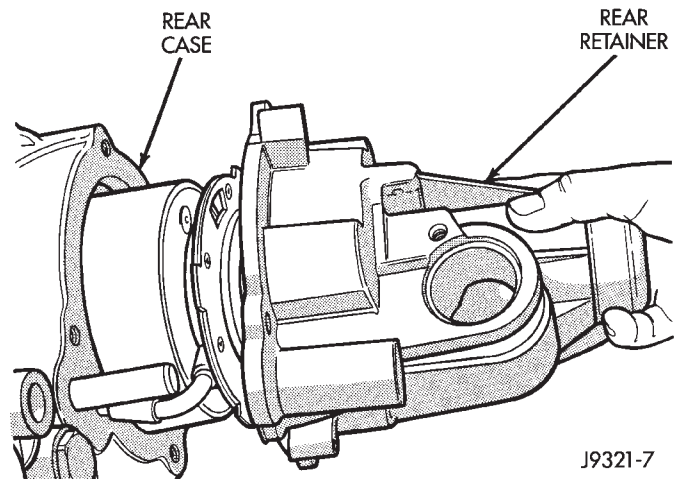


Fig. 80 Rear Retainer Installation

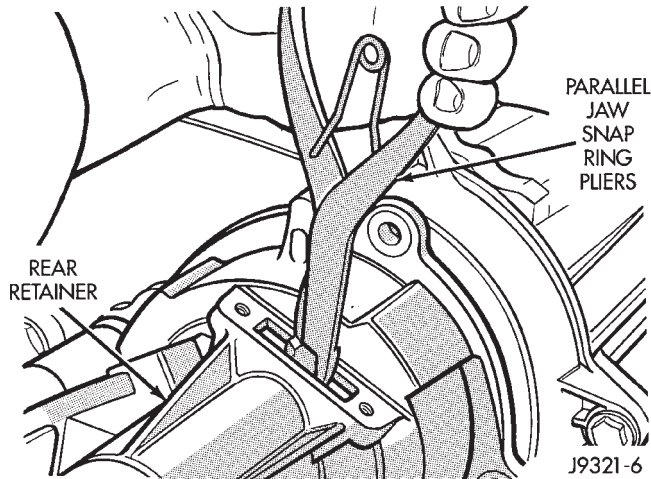
DISASSEMBLY AND ASSEMBLY (Continued)

Fig. 81 Engaging Rear Bearing Locating Ring

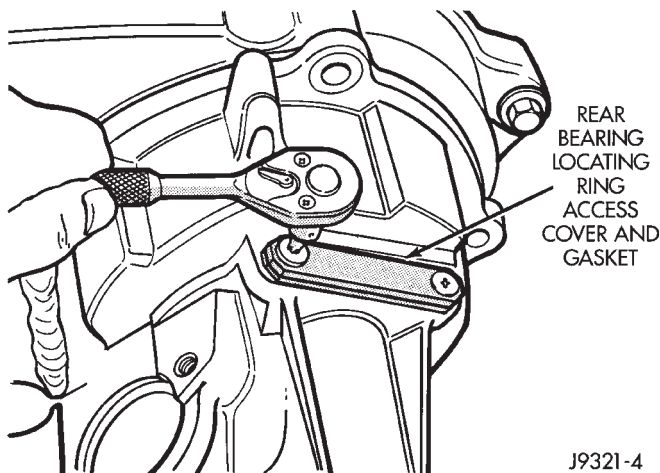


Fig. 82 Installing Locating Ring Access Cover And Gasket

FINAL ASSEMBLY

- (1) Install drain plug. Tighten plug to 41-54 N·m (30-40 ft. lbs.) torque.
- (2) Level transfer case and fill it with Mopar Dexron II automatic transmission fluid. Correct fill level is to bottom edge of fill plug hole.
- (3) Install and tighten fill plug to 41-54 N·m (30-40 ft. lbs.) torque.

CLEANING AND INSPECTION**NV249 COMPONENTS****GENERAL**

Clean the transfer case components with parts cleaning solvent. Flush the oil passages in the cases and drivetrain components with solvent. This will help remove dirt and particles from these passages.

Dry the transfer case components with compressed air or allow them to air dry on clean shop towels.

Apply compressed air through all oil passages in the cases and gear components to clear them of any residue.

MAINSHAFT

Examine the mainshaft components carefully for evidence of wear or damage.

Replace the thrust washers if worn or damaged.

Replace the mainshaft and sprocket gears if the teeth or gear bores are worn or damaged.

Replace the mainshaft bearings if worn, flat spotted, brinelled, or damaged in any way.

Replace the mainshaft if it exhibits wear or damage to the bearing surfaces, splines or gear teeth.

INPUT AND LOW RANGE GEARS

Inspect the low range gear pinions and pinion pins. Replace the low range gear if any of the pins or pinions are worn or damaged.

Inspect the thrust washers, retainer, and snapping. Replace the snap-ring if bent, or distorted. Replace the thrust washers and retainer if worn, cracked or damaged in any way.

Examine the input gear carefully. Be sure the gear teeth and bearing surfaces are in good condition. Replace the gear if wear or damage is evident.

Check the input gear pilot bearing. Rotate the bearing and check for roughness or noise. Also check bearing position in the bore. The bearing should be recessed approximately 2.5 mm (0.100 in.) below the top edge of the bore. The bearing should not be seated at the bottom of the bore. Replace the bearing if worn, or roughness is evident. Replace both the gear and bearing if the bearing is a loose fit in the bore.

GEAR CASE AND RETAINERS

Examine both case halves and retainers carefully. Replace any retainer or case half if wear, cracks, or other damage is evident.

Check condition of the low range annulus gear and the shift rail bushing in the front case (Fig. 83). The low range annulus gear is not a serviceable part. Replace the gear and case as an assembly if the gear is loose, worn, or damaged. The shift rail bushing is a serviceable part and can be replaced if necessary.

Check the bushing in the rear retainer. Replace the bushing if worn or scored.

Examine the sealing surfaces of both case halves and retainers. Small burrs, or scratches on these surfaces can be reduced with crocus cloth or a fine tooth file.

Examine condition of the shift rail bushing in the front case. If the bushing is worn or damaged, it can be removed with a blind hole type puller. A replacement bushing can be installed with a suitable size

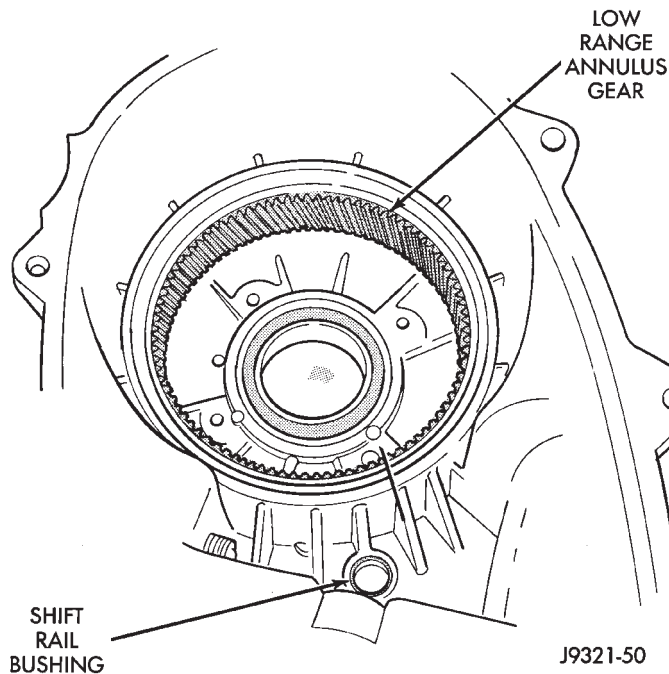
CLEANING AND INSPECTION (Continued)

Fig. 83 Low Range Annulus Gear Location

driver. Recess the bushing slightly below the edge of the bore but do not seat it all the into the case.

GEARTRAIN

Inspect the mainshaft splines, gear teeth and bearing surfaces carefully for evidence of wear, or damage. Replace the shaft if necessary. do not attempt to salvage it if damaged.

The shift rail and range fork are an assembly. Replace both parts if either is damaged. However, the

nylon pads in the fork can be replaced if worn, or cracked.

Inspect the transfer case snap rings closely. Do not attempt to salvage a distorted snap ring by straightening or reshaping it. Replace any snap ring that is distorted, or worn.

Inspect the low range gear, input gear and the gear thrust washers retainer, and snap ring. The low range gear is serviced as an assembly only. Replace the gear if the case or pinions are damaged.

During inspection, also make sure the seal surface of the input gear is in good condition. Minor nicks on this surface can be reduced with crocus cloth. However, replace the gear if the seal surface is severely scored or worn.

The speedometer gear should be replaced if worn, cracked, or if the small spline teeth are worn.

OIL PUMP AND VISCOUS COUPLING

The oil pump and viscous coupling are not serviceable components. Replace the coupling as an assembly if it is leaking or damaged. Replace the oil pump as an assembly if the gear teeth are worn, or if the pump has become damaged.

BEARINGS AND SEALS

The transfer case seals should be replaced during overhaul. Use new seals in the input gear bearing retainer, front case and rear retainer. Also replace the yoke seal washer and the detent plug O-ring.

Check condition of each transfer case bearing. Replace any bearing exhibiting signs of roughness, wear, or damage.

ADJUSTMENTS

SHIFT LINKAGE ADJUSTMENT

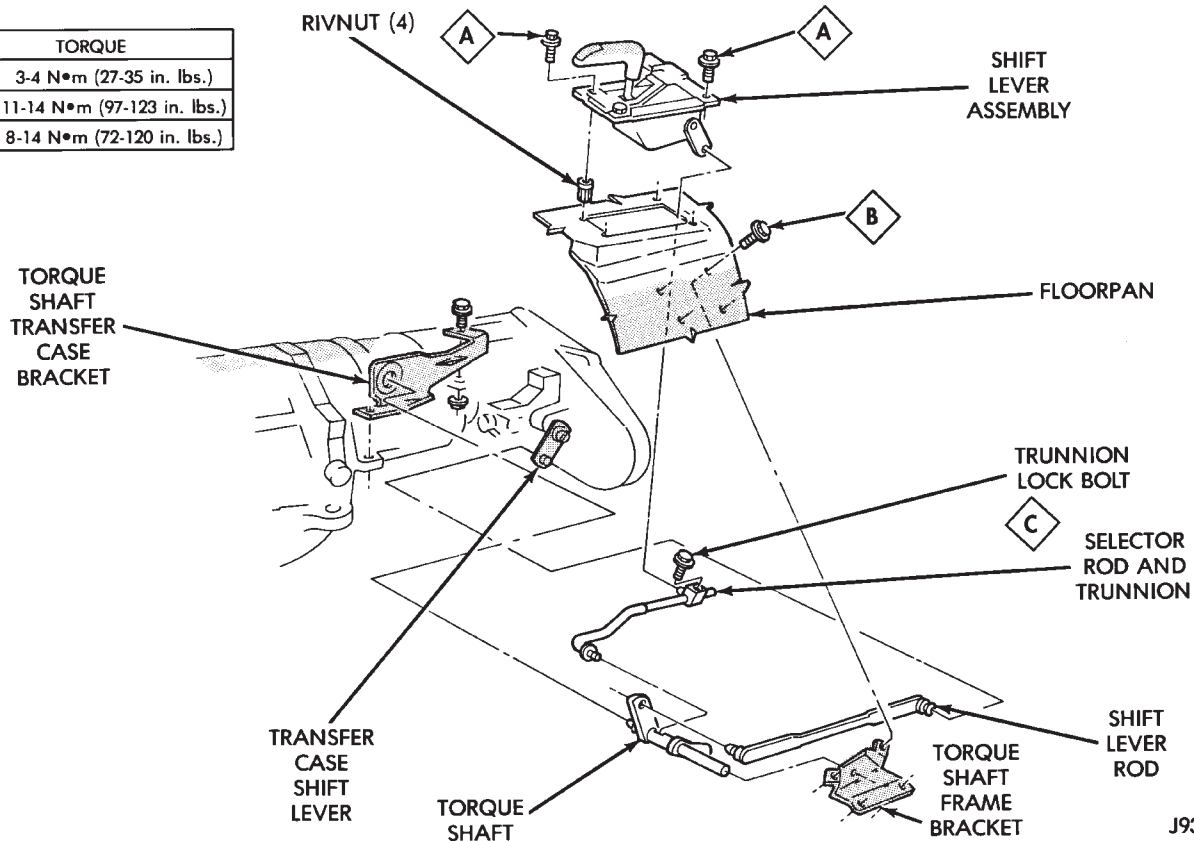
- (1) Shift transfer case into Neutral position.
- (2) Raise vehicle on hoist that will allow all four wheels to rotate freely.
- (3) Loosen trunnion lock bolt (Fig. 84). Loosen bolt enough so selector rod slides freely in trunnion.
- (4) Verify that shift lever on transfer case is in Neutral position.
- (5) Tighten trunnion lock bolt to 11-20 N·m (96-180 in. lbs.) torque.
- (6) Lower vehicle enough for entry into driver seat but keep all wheels off shop floor.
- (7) Verify correct linkage adjustment. Start engine, shift transmission into gear and shift transfer case into all ranges. Be sure transfer case is fully engaged in high and low range. Readjust linkage if necessary.
- (8) Shut engine off and lower vehicle completely.

SPECIFICATIONS

TORQUE

DESCRIPTION	TORQUE
Bolt, crossmember	41-47 N·m (30-35 ft. lbs.)
Plug, Detent	16-24 N·m (12-18 ft. lbs.)
Plugs, drain/fill	41-54 N·m (30-40 ft. lbs.)
Switch, Electric	20-34 N·m (15-25 ft. lbs.)
Bolts, front brg. retainer	16-24 N·m (12-18 ft. lbs.)
Bolts, case half	27-34 N·m (20-25 ft. lbs.)
Nut, output yoke	122-176 N·m (90-130 ft. lbs.)
Bolts, rear extension	27-34 N·m (20-25 ft. lbs.)
Lock-nut, shift	27-34 N·m (20-25 ft. lbs.)
Bolt, shift rod	11-20 N·m (96-180 in. lbs.)
Nuts, T-case mount stud	33-41 N·m (24-30 ft. lbs.)
Bolt, U-joint clamp	16-22 N·m (12-16 ft. lbs.)

TORQUE	
A	3-4 N·m (27-35 in. lbs.)
B	11-14 N·m (97-123 in. lbs.)
C	8-14 N·m (72-120 in. lbs.)

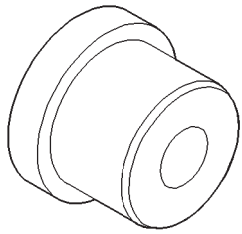


J9321-185

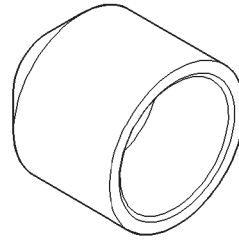
Fig. 84 Transfer Case Shift Linkage

SPECIAL TOOLS

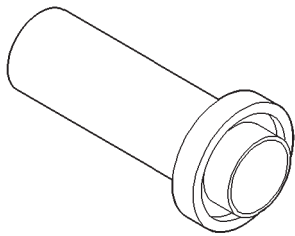
NV249 TRANSFER CASE



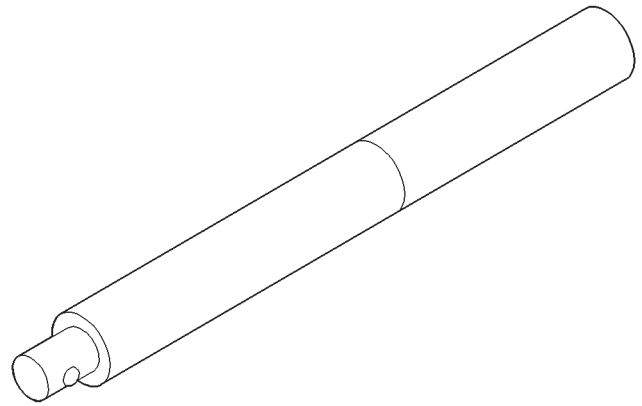
Installer—5066



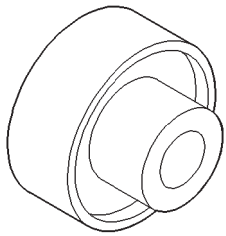
Installer—C-3995-A



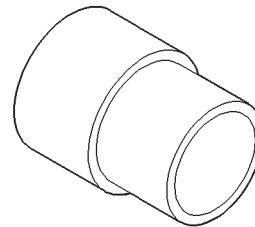
Installer—6952-A



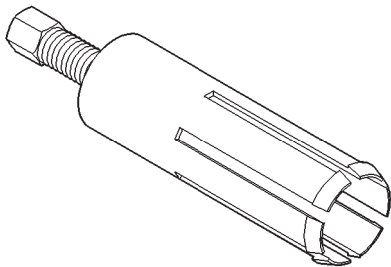
Handle—C-4171



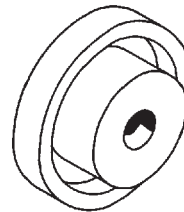
Installer—6953



Installer—8145

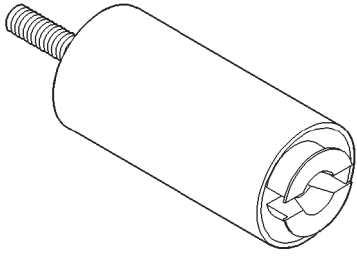


Remover—6957

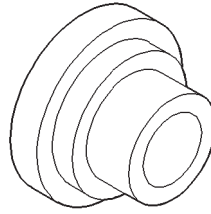


Remover—C-4210

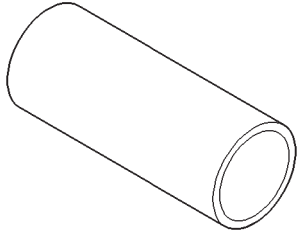
SPECIAL TOOLS (Continued)



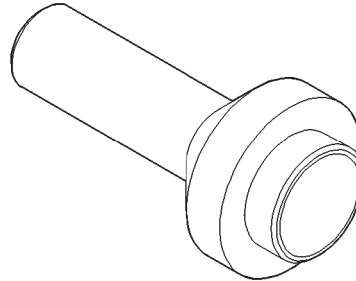
Remover—L-4454



Installer—8128



Cup—8148



Installer—7884

TRANSMISSION AND TRANSFER CASE

CONTENTS

	page		page
AX15 MANUAL TRANSMISSION	1	NV231 TRANSFER CASE	7

AX15 MANUAL TRANSMISSION

GENERAL INFORMATION

AX 15 MANUAL TRANSMISSION

The AX 15 is a 5-speed, synchromesh, manual transmission. Fifth gear is an overdrive range with a ratio of 0.79:1. The shift mechanism is integral and mounted in the shift tower portion of the adapter housing (Fig. 1).

TRANSMISSION IDENTIFICATION

The AX 15 identification code numbers are on the bottom surface of the transmission gear case (Fig. 2).
 The first number is year of manufacture. The second and third numbers indicate month of manufacture. The next series of numbers is the transmission serial number.

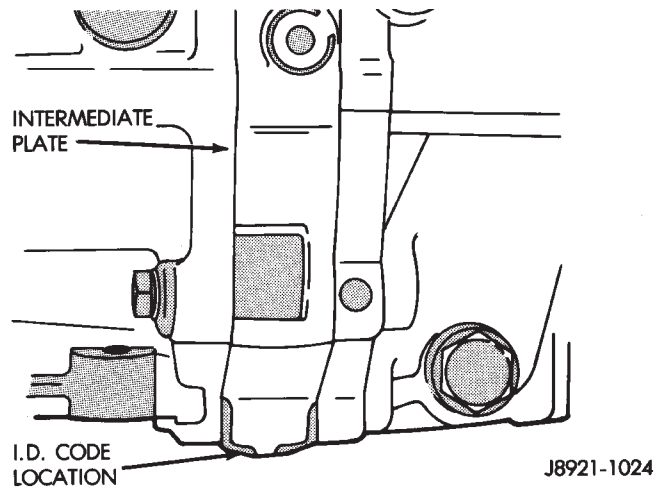


Fig. 2 Identification Code Number Location

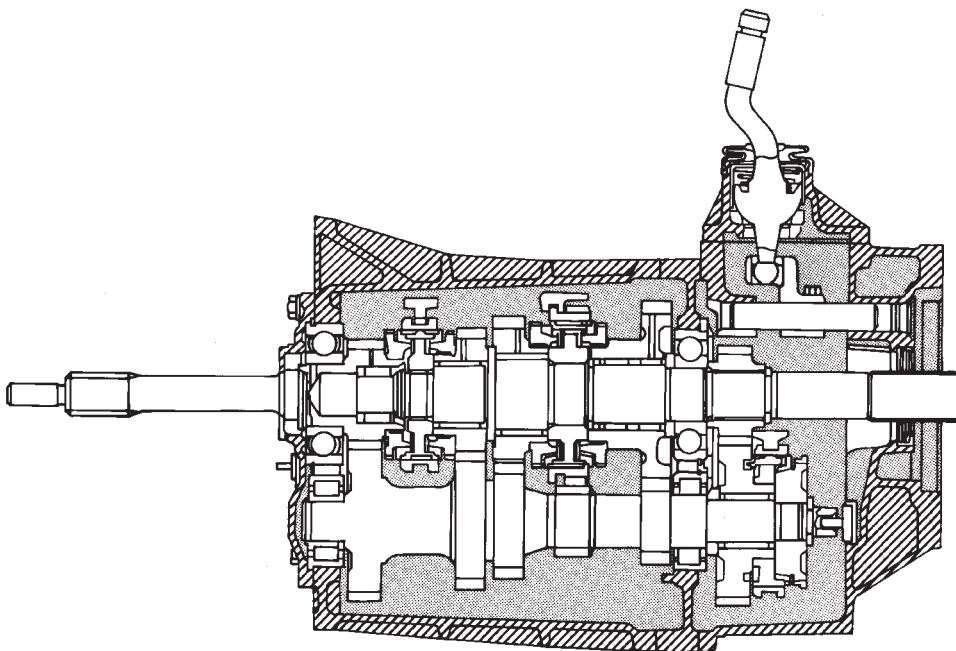


Fig. 1 AX 15 Manual Transmission

GENERAL INFORMATION (Continued)

TRANSMISSION SHIFT PATTERN

The AX 15 shift pattern is shown in (Fig. 3). First and second and third and fourth gear ranges are in line for improved shifting. Fifth and reverse gear ranges are also in line at the extreme right of the pattern (Fig. 3).

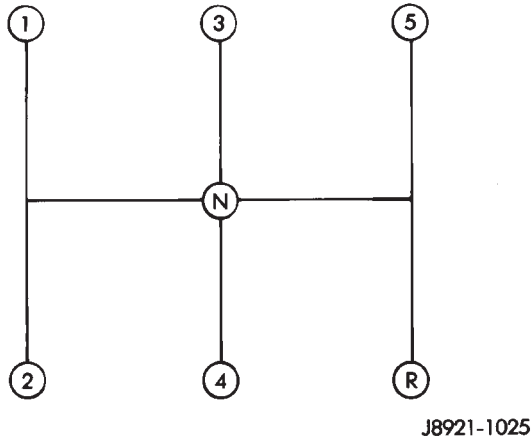


Fig. 3 AX 15 Shift Pattern

The AX 15 is equipped with a reverse lockout mechanism. The shift lever must be moved through the Neutral detent before making a shift to reverse.

TRANSMISSION LUBRICANT

Recommended lubricant for AX 15 transmissions is Mopar 75W-90, API Grade GL-5 gear lubricant, or equivalent.

Correct lubricant level is from the bottom edge, to no more than 6 mm (1/4 in.) below the bottom edge of the fill plug hole.

Approximate dry fill lubricant capacity is:

- 3.10 liters (3.27 qts.) in 4-wheel drive models

TRANSMISSION SWITCH AND PLUG LOCATIONS

The fill plug is at the driver side of the gear case (Fig. 4).

The drain plug and backup light switch are on the passenger side of the gear case (Fig. 5).

TRANSMISSION GEAR RATIOS

AX 15 gear ratios are:

First gear	3.83:1
Second gear	2.33:1
Third gear	1.44:1
Fourth gear	1.00:1
Fifth gear	0.79:1
Reverse	4.22:1

TRANSMISSION ASSEMBLY INFORMATION

Lubricate the transmission components with gear lubricant during assembly. Use petroleum jelly to

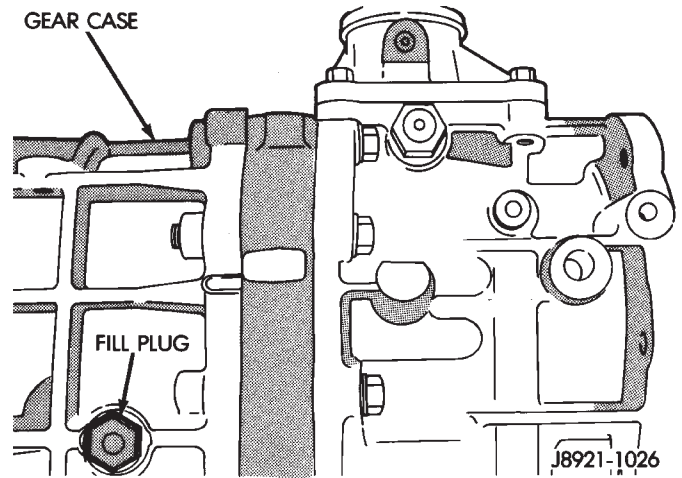


Fig. 4 Fill Plug Location

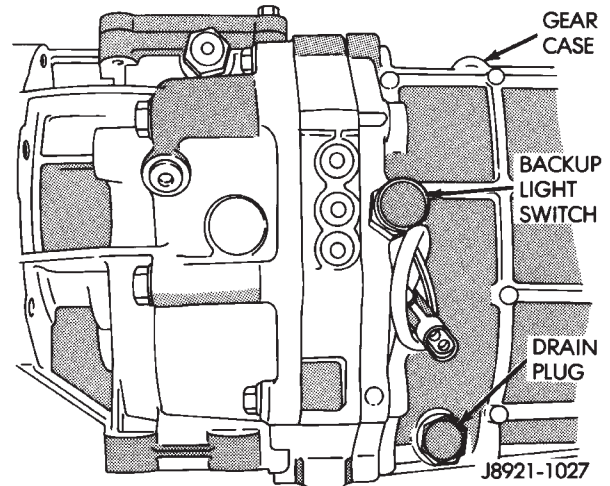


Fig. 5 Drain Plug/Backup Light Switch Location

lubricate seal lips and/or hold parts in place during installation.

DIAGNOSIS AND TESTING

LOW LUBRICANT LEVEL

A low transmission lubricant level is generally the result of a leak, inadequate lubricant fill, or an incorrect lubricant level check.

Leaks can occur at the mating surfaces of the gear case, intermediate plate and adapter or extension housing, or from the front/rear seals. A suspected leak could also be the result of an overfill condition.

Leaks at the rear of the extension or adapter housing will be from the housing oil seals. Leaks at component mating surfaces will usually be the result of inadequate sealer, gaps in the sealer, incorrect bolt tightening, or use of a non-recommended sealer.

A leak at the front of the transmission will be from either the front bearing retainer or retainer seal. Lubricant may be seen dripping from the clutch

DIAGNOSIS AND TESTING (Continued)

housing after extended operation. If the leak is severe, it may also contaminate the clutch disc causing slip, grab and chatter.

Transmissions filled from air or electrically powered lubricant containers can be under filled. This generally happens when the container delivery mechanism is improperly calibrated. Always check the lubricant level after filling to avoid an under fill condition.

A correct lubricant level check can only be made when the vehicle is level; use a drive-on hoist to ensure this. Also allow the lubricant to settle for a minute or so before checking. These recommendations will ensure an accurate check and avoid an under-or-over fill condition.

HARD SHIFTING

Hard shifting is usually caused by a low lubricant level, improper or contaminated lubricants, component damage, incorrect clutch adjustment, or by a damaged clutch pressure plate or disc.

Substantial lubricant leaks can result in gear, shift rail, synchro and bearing damage. If a leak goes undetected for an extended period, the first indications of a problem are usually hard shifting and noise.

Incorrect or contaminated lubricants can also contribute to hard shifting. The consequence of using non-recommended lubricants is noise, excessive wear, internal bind and hard shifting.

Improper clutch release is a frequent cause of hard shifting. Incorrect adjustment or a worn, damaged pressure plate or disc can cause incorrect release. If the clutch problem is advanced, gear clash during shifts can result.

Worn or damaged synchro rings can cause gear clash when shifting into any forward gear. In some new or rebuilt transmissions, new synchro rings may tend to stick slightly causing hard or noisy shifts. In most cases, this condition will decline as the rings wear-in.

TRANSMISSION NOISE

Most manual transmissions make some noise during normal operation. Rotating gears can generate a mild whine that may only be audible at extreme speeds.

Severe, obviously audible transmission noise is generally the result of a lubricant problem. Insufficient, improper, or contaminated lubricant can promote rapid wear of gears, synchros, shift rails, forks and bearings. The overheating caused by a lubricant problem, can also lead to gear breakage.

REMOVAL AND INSTALLATION

TRANSMISSION

REMOVAL

1. Disconnect the battery negative cable.
2. Remove the shifter boot and shifter.
3. Raise the vehicle on a hoist.
4. Drain the transmission fluid (Fig. 6).

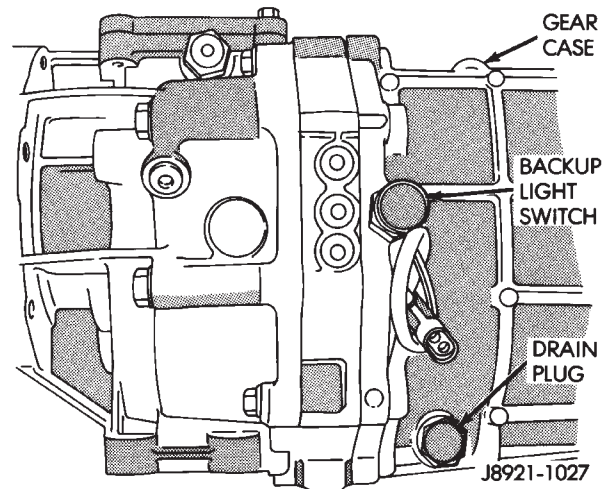


Fig. 6 Drain Plug and Backup Light Switch Location

5. Support the engine and transmission with an adjustable jack stand.
6. Remove exhaust pipe and heat shield.
7. Mark the front and rear propeller shafts for installation alignment (Fig. 7).

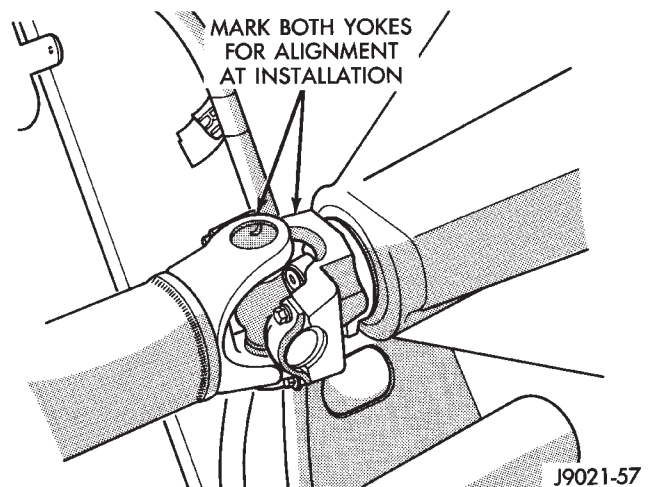
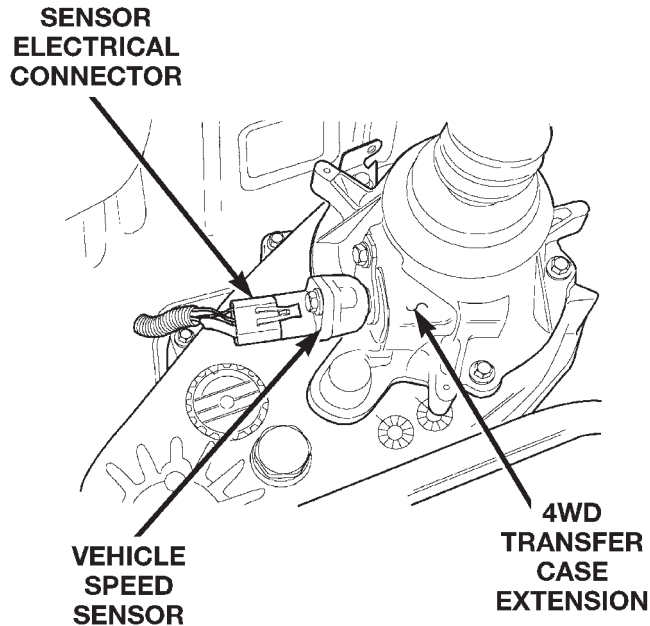


Fig. 7 Marking Propeller Shaft and Axle Yoke

8. Remove the front propeller shaft.
9. Remove the rear propeller shaft.
10. Remove the transmission skid plate.

REMOVAL AND INSTALLATION (Continued)

11. Disconnect the transfer case linkage and vehicle speed sensor electrical connector and vent tube hose (Fig. 8).



80a35409

Fig. 8 Vehicle Speed Sensor

12. Reposition the adjustable jackstand under the engine.

13. Place a transmission jack under the transmission and secure the transmission with safety chains.

14. Remove the rear transmission mount.

15. Remove the rear crossmember.

16. Remove the transfer case assembly. Refer to Transfer Case removal later in this Group.

17. Lower the engine and transmission no more than 7.6 cm.

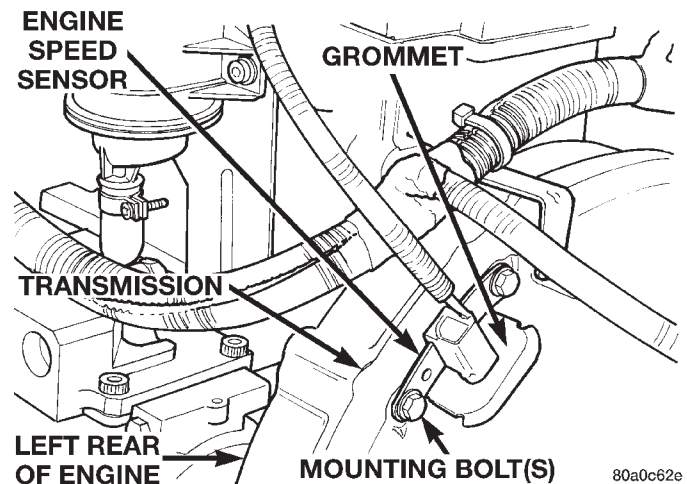
18. Remove the two (2) upper and two (2) mid clutch housing to engine bolts.

19. Remove the engine speed sensor (crankshaft position sensor) (Fig. 9).

20. Remove the clutch slave cylinder from the clutch housing.

21. Remove the lower transmission bolts.

22. Remove the transmission assembly from the vehicle.



80a0c62e

Fig. 9 Engine Speed Sensor**INSTALLATION**

1. Mount the transmission on a transmission jack and secure the transmission with safety chains.

2. Install the transmission to the vehicle (Fig. 10).

3. Install the two (2) lower transmission bolts. Tighten the bolts to 74.6 N·m.

4. Install the clutch slave cylinder to the clutch housing.

5. Install the engine speed sensor (crankshaft position sensor) to the vehicle (Fig. 9).

6. Install the two (2) upper clutch housing to engine bolts. Tighten the bolts to 36.6 N·m.

7. Install the two (2) mid clutch housing to engine bolts. Tighten the bolts to 58.3 N·m.

8. Raise the engine and transmission with the adjustable jackstand.

9. Install the transfer case assembly. Refer to Transfer Case installation later in this Group.

10. Install the rear crossmember.

11. Install the rear transmission mount.

12. Connect the transfer case linkage and vehicle speed sensor electrical connector and vent tube (Fig. 8).

13. Install the transmission skid plate.

14. Align and install the front and rear propeller shafts.

15. Install the exhaust pipe and heat shield.

REMOVAL AND INSTALLATION (Continued)

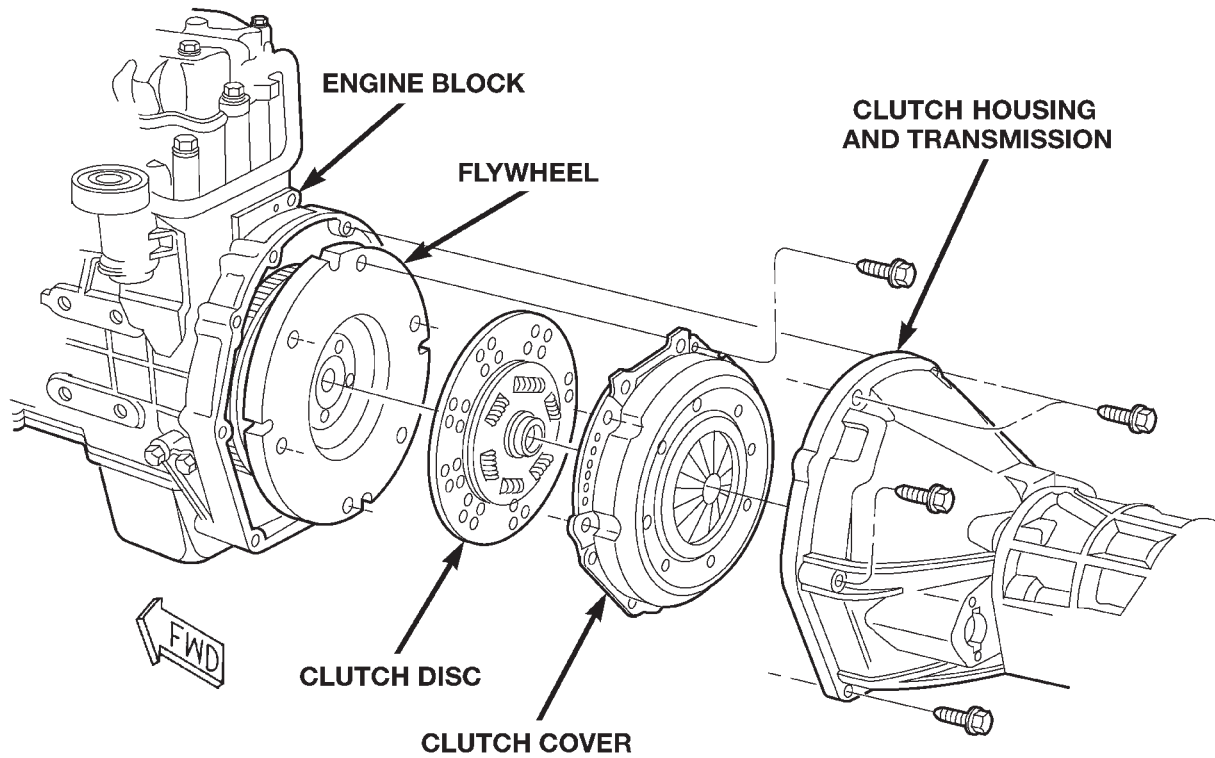


Fig. 10 Transmission to Engine Mounting

80abfe70

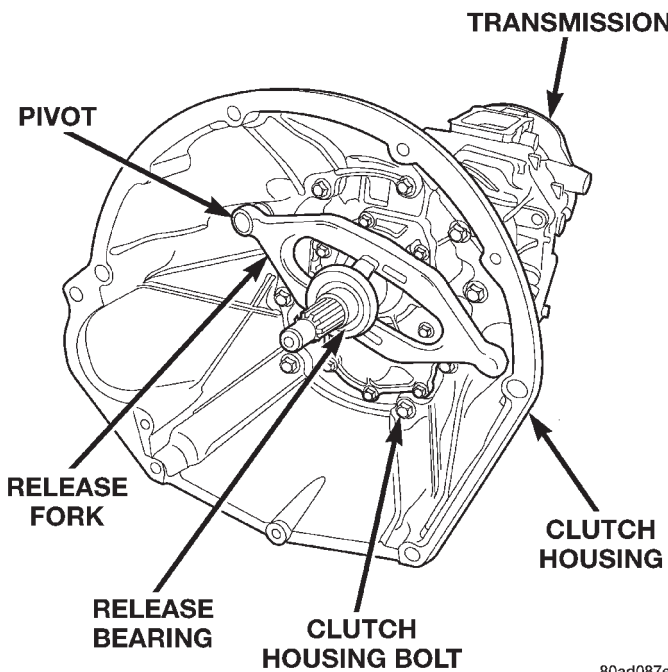


Fig. 11 Clutch Housing to Transmission

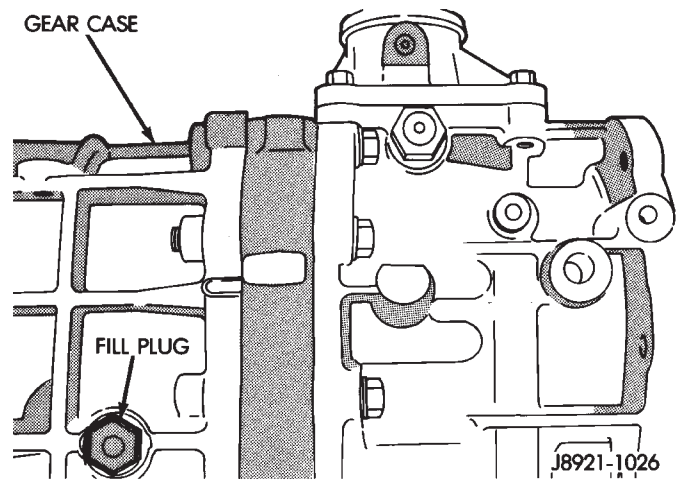


Fig. 12 Fill Plug Location

- 16. Remove the transmission jack.
- 17. Fill the transmission with the proper fluid (Fig. 12).

- 18. Remove the adjustable jackstand from under the engine.
- 19. Lower the vehicle from the hoist.
- 20. Install the shifter boot and shifter.
- 21. Reconnect the battery negative cable.

80ad087e

SPECIFICATIONS**TORQUE**

DESCRIPTION	TORQUE
Clutch Housing to Engine Top (2) Bolts	36.6 N·m (27 ft. lbs.)
Clutch Housing to Engine Mid-Point (2) Bolts	58.3 N·m (43 ft. lbs.)
Clutch Housing to Engine Bottom (2) Bolts	74.6 N·m (55 ft. lbs.)
Clutch Housing to Transmission bolts	38.0 N·m (28 ft. lbs.)
Transfer Case to Transmission Attaching Nuts	35 N·m (26 ft. lbs.)
Propeller Shaft Bolts	26.5 N·m (19.5 ft. lbs.)

NV231 TRANSFER CASE

GENERAL INFORMATION

NV231 TRANSFER CASE

The NV231 is a part-time transfer case with a low range reduction gear system. The NV231 has three operating ranges plus a Neutral position. A low range system provides a reduction ratio for increased low speed torque capability.

The input gear is splined to the transmission output shaft. The input gear drives the mainshaft through the planetary assembly and range hub. The front output shaft is operated by a drive chain that connects the shaft to a drive sprocket on the mainshaft. The drive sprocket is engaged/disengaged by the mode fork, which operates the mode sleeve and hub. The sleeve and hub are not equipped with a synchronizer mechanism for shifting.

The geartrain is mounted in two aluminum case halves attached with bolts. The mainshaft front and rear bearings are mounted in aluminum retainer housings bolted to the case halves.

OPERATING RANGES

Transfer case operating ranges are:

- 2WD (2-wheel drive)
- 4x4 (4-wheel drive)
- 4 Lo (4-wheel drive low range)

The 2WD range is for use on any road surface at any time.

The 4x4 and 4 Lo ranges are for off road use only. They are not for use on hard surface roads. The only exception being when the road surface is wet or slippery or covered by ice and snow.

The low range reduction gear system is operative in 4 Lo range only. This range is for extra pulling power in off road situations. Low range reduction ratio is 2.72:1.

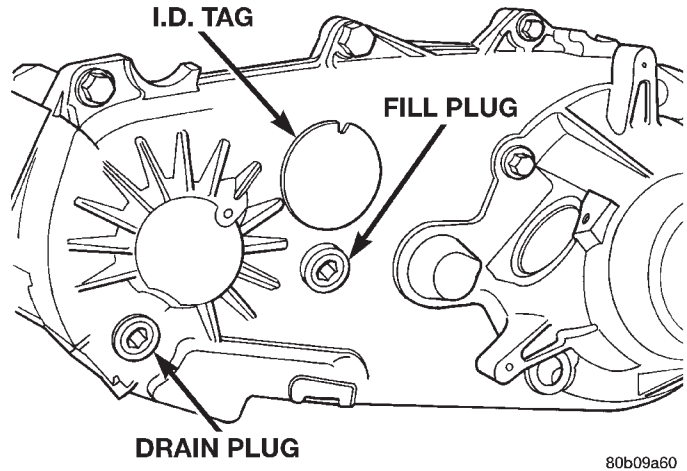
SHIFT MECHANISM

Operating ranges are selected with a floor mounted shift lever. The shift lever is connected to the transfer case range lever by an adjustable linkage rod. A straight line shift pattern is used. Range positions are marked on the shifter bezel cover plate.

TRANSFER CASE IDENTIFICATION

A circular ID tag is attached to the rear case of each transfer case (Fig. 1). The ID tag provides the transfer case model number, assembly number, serial number, and low range ratio.

The transfer case serial number also represents the date of build.



80b09a60

Fig. 1 Fill/Drain Plug And I.D. Tag Locations

RECOMMENDED LUBRICANT AND FILL LEVEL

Recommended lubricant for the NV231 transfer case is Mopar® Dexron II, or ATF Plus 3, type 7176. Approximate lubricant fill capacity is 1.2 liters (2.5 pints).

The fill and drain plugs are both in the rear case (Fig. 1). Correct fill level is to the bottom edge of the fill plug hole. Be sure the vehicle is level to ensure an accurate fluid level check.

DIAGNOSIS AND TESTING**NV231 DIAGNOSIS****DIAGNOSIS CHART**

CONDITION	POSSIBLE CAUSE	CORRECTION
Transfer case difficult to shift or will not shift into desired range.	<ol style="list-style-type: none"> 1) Vehicle speed too great to permit shifting. 2) If vehicle was operated for an extended period in 4H mode on dry surface, driveline torque load may cause difficulty. 3) Transfer case shift linkage binding. 4) Insufficient or incorrect lubricant. 5) Internal transfer case components binding, worn, or damaged. 	<ol style="list-style-type: none"> 1) Slow vehicle and shift into desired range. 2) Stop vehicle and shift transfer case to Neutral position. Transfer case can then be shifted to the desired mode. 3) Repair or replace linkage as necessary. 4) Drain and refill transfer case with the correct type and quantity of lubricant. 5) Repair or replace components as necessary.
Transfer case noisy in all drive modes.	<ol style="list-style-type: none"> 1) Insufficient or incorrect lubricant. 	<ol style="list-style-type: none"> 1) Drain and refill transfer case with the correct type and quantity of lubricant.
Transfer case noisy while in, or jumps out of, 4L mode.	<ol style="list-style-type: none"> 1) Transfer case not completely engaged in 4L position. 2) Transfer case shift linkage out of adjustment. 3) Transfer case shift linkage loose or binding. 4) Range fork damaged, inserts worn, or fork is binding on the shift rail. 5) Low range gear worn or damaged. 	<ol style="list-style-type: none"> 1) Slow vehicle, shift transfer case to the Neutral position, and then shift into the 4L mode. 2) Adjust linkage as necessary. 3) Repair, replace, or tighten linkage components as necessary. 4) Repair or replace components as necessary. 5) Repair or replace components as necessary.
Lubricant leaking from transfer case seals or vent.	<ol style="list-style-type: none"> 1) Transfer case overfilled. 2) Transfer case vent closed or restricted. 3) Transfer case seals damaged or installed incorrectly. 	<ol style="list-style-type: none"> 1) Drain lubricant to the correct level. 2) Clean or replace vent as necessary. 3) Replace suspect seal.
Abnormal tire wear.	<ol style="list-style-type: none"> 1) Extended operation in 4H mode on dry surfaces, 	<ol style="list-style-type: none"> 1) Operate vehicle in 2H mode on dry surfaces.

REMOVAL AND INSTALLATION

TRANSFER CASE

REMOVAL

- (1) Shift transfer case into Neutral.
- (2) Raise vehicle.
- (3) Drain transfer case lubricant.
- (4) Mark front and rear propeller shaft yokes for alignment reference.
- (5) Support transmission with jack stand.
- (6) Remove rear crossmember and skid plate, if equipped.
- (7) Disconnect front/rear propeller shafts at transfer case.
- (8) Disconnect vehicle speed sensor wires.
- (9) Disconnect transfer case linkage rod from range lever.
- (10) Disconnect transfer case vent hose (Fig. 2) and indicator switch harness, if necessary.
- (11) Support transfer case with transmission jack.
- (12) Secure transfer case to jack with chains.
- (13) Remove nuts attaching transfer case to transmission.
- (14) Pull transfer case and jack rearward to disengage transfer case.
- (15) Remove transfer case from under vehicle.

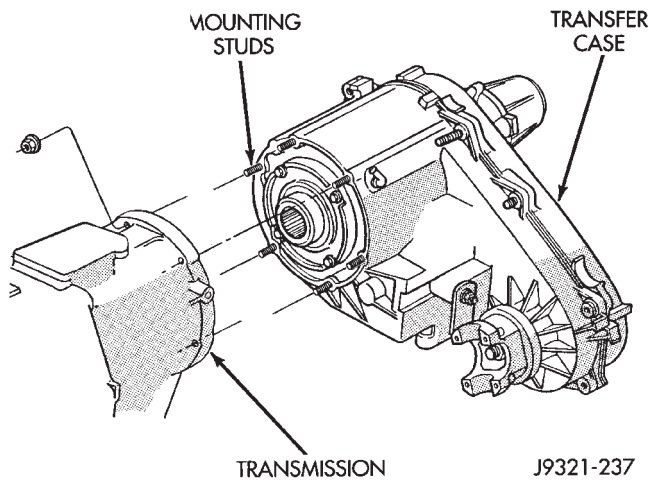


Fig. 2 Transfer Case Mounting

INSTALLATION

- (1) Mount transfer case on a transmission jack.
- (2) Secure transfer case to jack with chains.
- (3) Position transfer case under vehicle.

- (4) Align transfer case and transmission shafts and install transfer case on transmission.
- (5) Install and tighten transfer case attaching nuts to 35 N·m (Fig. 2).
- (6) Connect vehicle speed sensor wires, and vent hose.
- (7) Connect indicator switch harness to transfer case switch, if necessary. Secure wire harness to clips on transfer case.
- (8) Align and connect propeller shafts. Tighten shaft attaching bolts to 26.5 N·m torque.
- (9) Fill transfer case with correct fluid. Refer to Recommended Lubricant And Fill Level section for proper fluid and capacity.
- (10) Install rear crossmember and skid plate, if equipped. Tighten crossmember bolts.
- (11) Remove transmission jack and support stand.
- (12) Connect shift rod to transfer case range lever.
- (13) Adjust transfer case shift linkage.
- (14) Lower vehicle and verify transfer case shift operation.

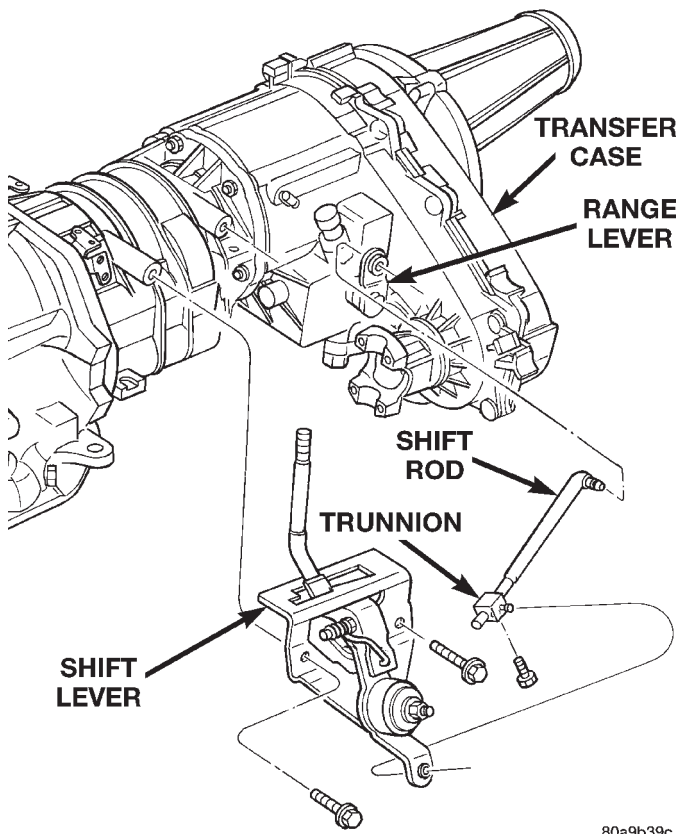
SHIFT LEVER

REMOVAL

- (1) Shift transfer case into 4L.
- (2) Remove transfer case shifter knob cap.
- (3) Remove nut holding shifter knob to shift lever.
- (4) Remove shifter knob.
- (5) Raise and support vehicle.
- (6) Loosen adjusting trunnion lock bolt and slide shift rod out of trunnion (Fig. 3). If rod lacks enough travel to come out of trunnion, push trunnion out of shift lever.
- (7) Remove bolts holding shift lever to transmission.
- (8) Separate shift lever from vehicle.

INSTALLATION

- (1) Position shift lever on transmission. Use care when passing the shift lever through the shifter boot to prevent damage to the shifter boot.
- (2) Install bolts to hold shift lever to transmission.
- (3) Install trunnion to shift lever, if necessary.
- (4) Install shift rod to trunnion, if necessary.
- (5) Move shift lever and transfer case to 4L position.

REMOVAL AND INSTALLATION (Continued)**Fig. 3 Shift Lever**

- (6) Tighten trunnion lock bolt.
- (7) Lower vehicle.
- (8) Install shift knob on shift lever.
- (9) Install nut to hold shifter knob to shift lever.
- (10) Install shifter knob cap.
- (11) Verify transfer case operation.

SPEEDOMETER**REMOVAL**

- (1) Raise vehicle.
- (2) Disconnect wires from vehicle speed sensor.
- (3) Remove adapter clamp and screw (Fig. 4).
- (4) Remove speed sensor and speedometer adapter as an assembly.
- (5) Remove speed sensor retaining screw and remove sensor from adapter.
- (6) Remove speedometer pinion from adapter. Replace pinion if chipped, cracked, or worn.

(7) Inspect sensor and adapter O-rings (Fig. 4). Remove and discard O-rings if worn or damaged.

(8) Inspect terminal pins in speed sensor. Clean pins with Mopar® electrical spray cleaner if dirty or oxidized. Replace sensor if faulty, or if pins are loose, severely corroded, or damaged.

INSTALLATION AND INDEXING

(1) Thoroughly clean adapter flange and adapter mounting surface in housing. Surfaces must be clean for proper adapter alignment and speedometer operation.

(2) Install new O-rings on speed sensor and speedometer adapter (Fig. 4), if necessary.

(3) Lubricate sensor and adapter O-rings with transmission fluid.

(4) Install vehicle speed sensor in speedometer adapter. Tighten sensor attaching screw to 2-3 N·m (15-27 in. lbs.) torque.

(5) Install speedometer pinion in adapter.

(6) Count number of teeth on speedometer pinion. Do this before installing assembly in housing. Then lubricate pinion teeth with transmission fluid.

(7) Note index numbers on adapter body (Fig. 5). These numbers will correspond to number of teeth on pinion.

(8) Install speedometer assembly in housing.

(9) Rotate adapter until required range numbers are at 6 o'clock position. Be sure range index numbers correspond to number of teeth on pinion gear.

(10) Install speedometer adapter clamp and retaining screw. Tighten clamp screw to 10-12 N·m (90-110 in. lbs.) torque.

(11) Connect wires to vehicle speed sensor.

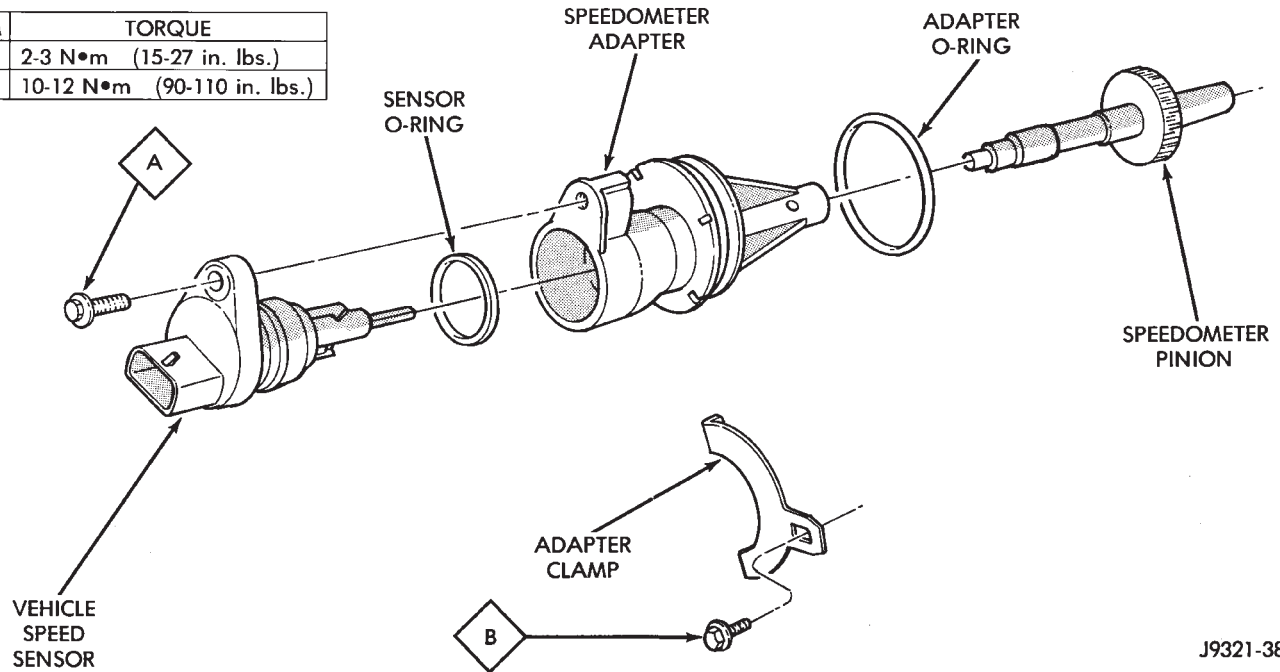
(12) Lower vehicle and top off transmission fluid level if necessary.

FRONT OUTPUT SHAFT SEAL**REMOVAL**

- (1) Raise vehicle.
- (2) Remove front propeller shaft. Refer to Group 3, Differential and Driveline, for proper procedure.
- (3) Remove front output shaft yoke.
- (4) Remove seal from front case with pry tool (Fig. 6).

REMOVAL AND INSTALLATION (Continued)

ITEM	TORQUE
A	2-3 N•m (15-27 in. lbs.)
B	10-12 N•m (90-110 in. lbs.)



J9321-385

Fig. 4 Speedometer Components

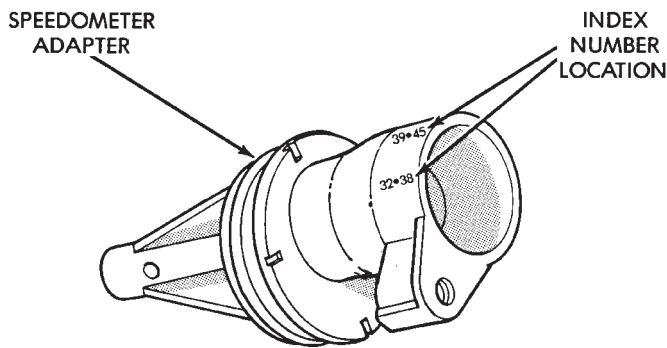
INSTALLATION

- (1) Install new front output seal in front case with Installer Tool 8143 as follows:
 - (a) Place new seal on tool. Garter spring on seal goes toward interior of case.
 - (b) Start seal in bore with light taps from hammer (Fig. 7). Once seal is started, continue tapping seal into bore until installer tool seats against case.

REAR RETAINER BUSHING AND SEAL

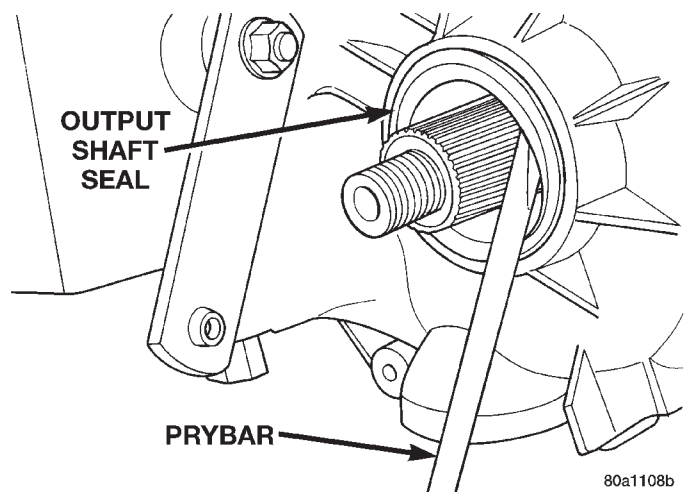
REMOVAL

- (1) Raise vehicle.
- (2) Remove rear propeller shaft. Refer to Group 3, Differential and Driveline, for proper procedure.
- (3) Using a suitable pry tool or slide-hammer mounted screw, remove the rear retainer seal.
- (4) Using Remover 6957, remove bushing from rear retainer (Fig. 8).



J9321-386

Fig. 5 Location Of Index Numbers On Speedometer Adapter



80a1108b

Fig. 6 Remove Front Output Shaft Seal

REMOVAL AND INSTALLATION (Continued)

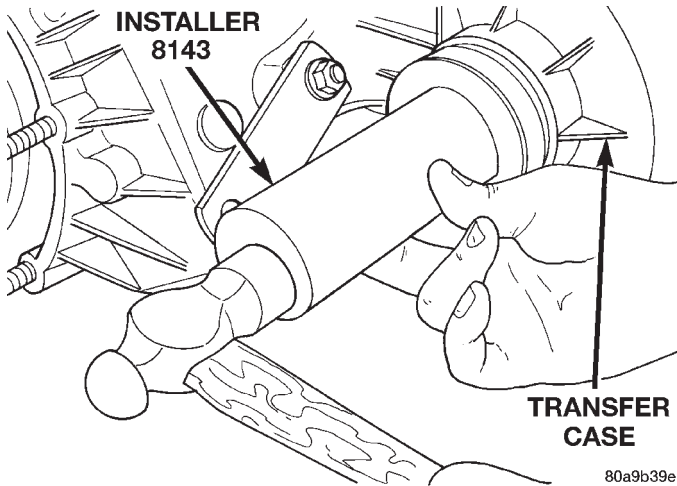


Fig. 7 Front Output Seal Installation

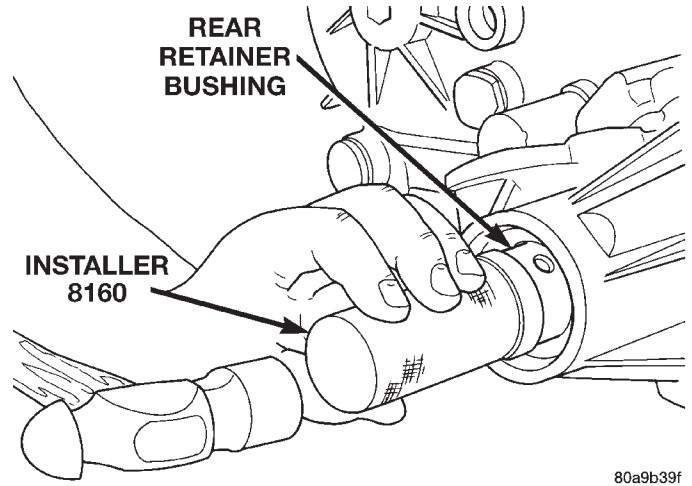


Fig. 9 Rear Retainer Bushing Install

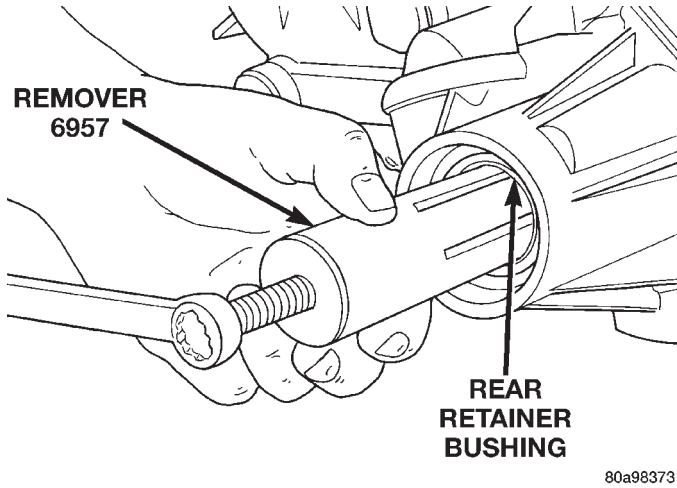


Fig. 8 Rear Retainer Bushing Removal

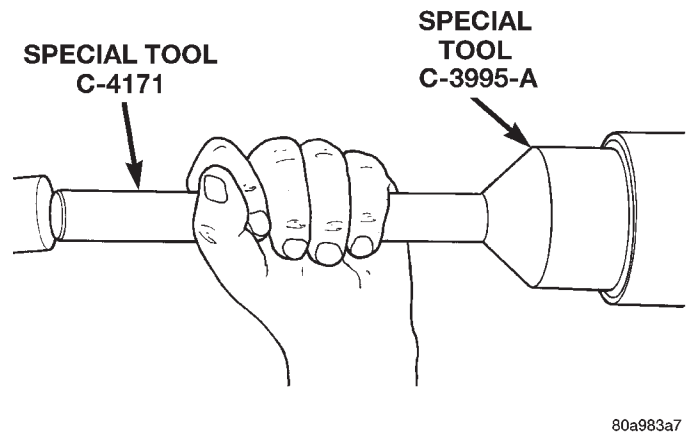


Fig. 10 Install Rear Retainer Seal

INSTALLATION

- (1) Clean fluid residue from sealing surface and inspect for defects.
- (2) Position replacement bushing in rear retainer with fluid port in bushing aligned with slot in retainer.
- (3) Using Installer 8160, drive bushing into retainer until installer seats against case (Fig. 9).
- (4) Using Installer C-3995-A, install seal in rear retainer (Fig. 10).
- (5) Install propeller shaft.
- (6) Verify proper fluid level.
- (7) Lower vehicle.

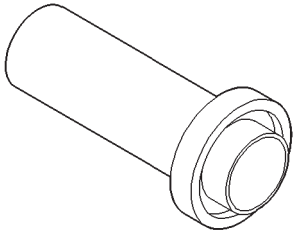
SPECIFICATIONS

TORQUE

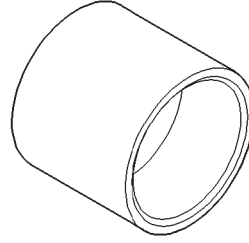
DESCRIPTION	TORQUE
Plug, Drain/Fill	40 N·m
Nuts, Mounting	35 N·m
Switch, Indicator	26 N·m

SPECIAL TOOLS

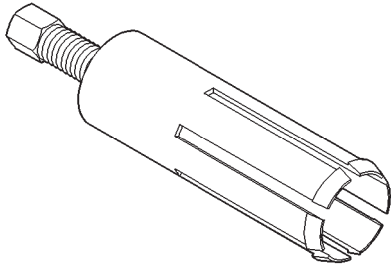
SPECIAL TOOLS—NV231



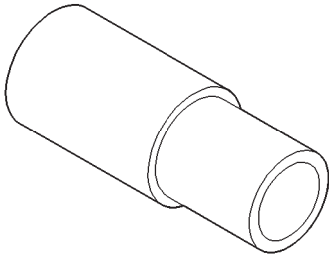
Installer, Seal—8143



Installer, Seal—C-3995-A



Remover, Bushing—6957



Installer, Bushing—8160

TIRES AND WHEELS

CONTENTS

	page		page
TIRES	1	WHEELS	7

TIRES

INDEX

	page		page
DESCRIPTION AND OPERATION			
RADIAL-PLY TIRES	2	TIRE NOISE OR VIBRATION	4
REPLACEMENT TIRES	3	TIRE WEAR PATTERNS	3
SPARE TIRE-TEMPORARY	2	TREAD WEAR INDICATORS	3
TIRE INFLATION PRESSURES	2	SERVICE PROCEDURES	
TIRE INFORMATION	1	MATCH MOUNTING	4
TIRE PRESSURE FOR HIGH SPEED		REPAIRING LEAKS	5
OPERATION	3	ROTATION	4
DIAGNOSIS AND TESTING			
PRESSURE GAUGES	3	CLEANING AND INSPECTION	
		CLEANING TIRES	6

DESCRIPTION AND OPERATION

TIRE INFORMATION

Tires are designed and engineered for each specific vehicle. They provide the best overall performance for normal operation. The ride and handling characteristics match the vehicle's requirements. With proper care they will give excellent reliability, traction, skid resistance, and tread life.

Driving habits have more effect on tire life than any other factor. Careful drivers will obtain in most cases, much greater mileage than severe use or careless drivers. A few of the driving habits which will shorten the life of any tire are:

- Rapid acceleration
- Severe brake applications
- High speed driving
- Excessive speeds on turns
- Striking curbs and other obstacles

Radial-ply tires are more prone to irregular tread wear. It is important to follow the tire rotation interval shown in the section on Tire Rotation. This will help to achieve a greater tread life.

TIRE IDENTIFICATION

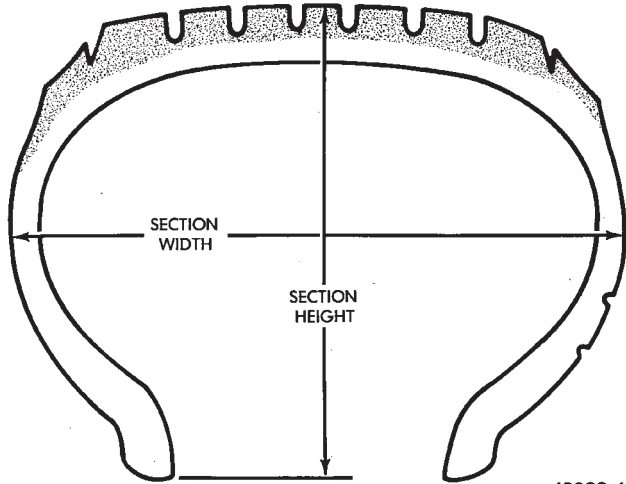
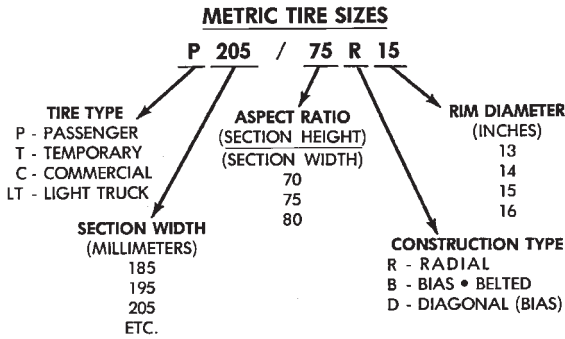
Tire type, size, aspect ratio and speed rating are encoded in the letters and numbers imprinted on the side wall of the tire. Refer to the chart to decipher the tire identification code (Fig. 1).

Performance tires have a speed rating letter after the aspect ratio number.

SPEED SYMBOL	SPEED RATING
S	180 km/h (112 mph)
T	190 km/h (118 mph)
U	200 km/h (124 mph)
H	210 km/h (130 mph)
V	240 km/h (149 mph)
W	270 km/h (168 mph)
Y	300 km/h (186 mph)

The speed rating is not always printed on the tire sidewall.

DESCRIPTION AND OPERATION (Continued)



J9322-6

Fig. 1 Tire Identification

TIRE CHAINS

Tire snow chains may be used on **certain** models. Refer to the Owner's Manual for more information.

RADIAL-PLY TIRES

Radial-ply tires improve handling, tread life, ride quality and decrease rolling resistance.

Radial-ply tires must always be used in sets of four. Under no circumstances should they be used on the front only. They may be mixed with temporary spare tires when necessary. A maximum speed of 50 MPH is recommended while a temporary spare is in use.

Radial-ply tires have the same load-carrying capacity as other types of tires of the same size. They also use the same recommended inflation pressures.

The use of oversized tires, either in the front or rear of the vehicle, can cause vehicle drive train failure. This could also cause inaccurate wheel speed signals when the vehicle is equipped with Anti-Lock Brakes.

The use of tires from different manufactures on the same vehicle is NOT recommended. The proper tire pressure should be maintained on all four tires. For proper tire pressure refer to the Tire Inflation Pressure Chart provided with the vehicle.

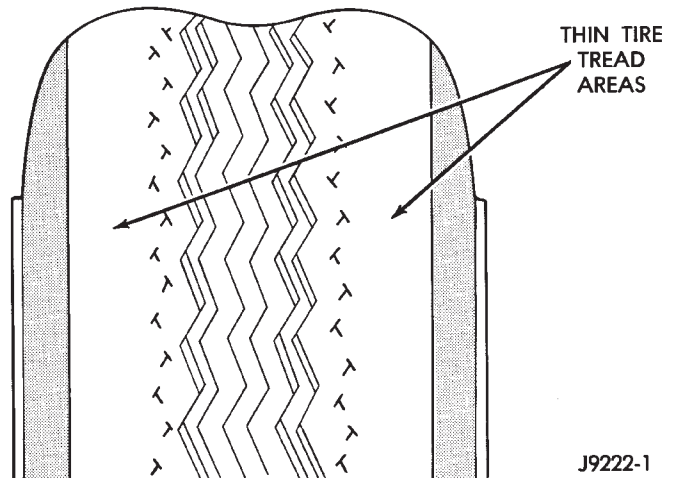
SPARE TIRE-TEMPORARY

The temporary spare tire is designed for emergency use only. The original tire should be repaired or replaced at the first opportunity and reinstall. Do not exceed speeds of 50 MPH. Refer to Owner's Manual for complete details.

TIRE INFLATION PRESSURES

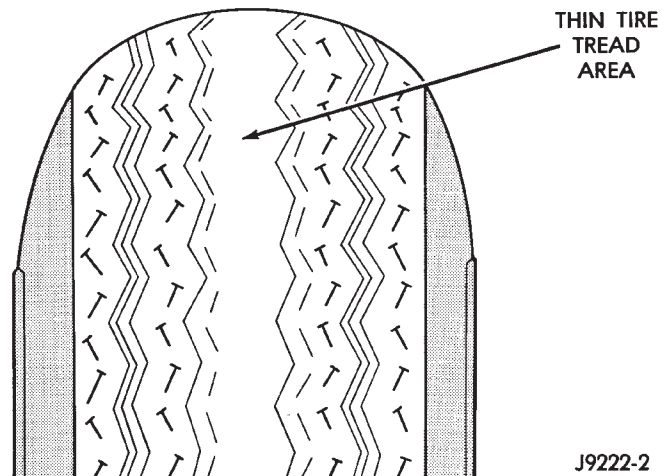
Under inflation will cause rapid shoulder wear, tire flexing, and possible tire failure (Fig. 2).

Over inflation will cause rapid center wear and loss of the tire's ability to cushion shocks (Fig. 3).



J9222-1

Fig. 2 Under Inflation Wear



J9222-2

Fig. 3 Over Inflation Wear

Improper inflation can cause:

- Uneven wear patterns
- Reduced tread life
- Reduced fuel economy
- Unsatisfactory ride
- Vehicle drift

For proper tire pressure specification refer to the Tire Inflation Pressure Chart provided with the vehicle.

DESCRIPTION AND OPERATION (Continued)

Tire pressures have been chosen to provide safe operation, vehicle stability, and a smooth ride. Tire pressure should be checked cold once a month. The spare tire pressure should be checked at least twice annually. Tire pressure decreases as the ambient temperature drops. Check tire pressure frequently when ambient temperature varies widely.

Inflation pressures specified on the placards are cold inflation pressure. The vehicle must sit for at least 3 hours to obtain the correct cold inflation pressure reading. Or driven less than one mile after sitting for 3 hours. Tire inflation pressures may increase from 2 to 6 pounds per square inch (psi) during operation, due to increased tire temperature.

WARNING: OVER OR UNDER INFLATED TIRES CAN AFFECT VEHICLE HANDLING AND TREAD WEAR. THIS MAY CAUSE THE TIRE TO FAIL SUDDENLY, RESULTING IN LOSS OF VEHICLE CONTROL.

TIRE PRESSURE FOR HIGH SPEED OPERATION

Chrysler Corporation advocates driving at safe speeds within posted speed limits. Where speed limits allow the vehicle to be driven at high speeds, correct tire inflation pressure is very important. For speeds up to and including 120 km/h (75 mph), tires must be inflated to the pressures shown on the tire placard.

Vehicles loaded to the maximum capacity should not be driven at continuous speeds above 75 mph (120 km/h).

For emergency vehicles that are driven at speeds over 90 mph (144 km/h), special high speed tires must be used. Consult tire manufacturer for correct inflation pressure recommendations.

REPLACEMENT TIRES

The original equipment tires provide a proper balance of many characteristics such as:

- Ride
- Noise
- Handling
- Durability
- Tread life
- Traction
- Rolling resistance
- Speed capability

It is recommended that tires equivalent to the original equipment tires be used when replacement is needed.

Failure to use equivalent replacement tires may adversely affect the safety and handling of the vehicle.

The use of oversize tires not listed in the specification charts may cause interference with vehicle com-

ponents. Under extremes of suspension and steering travel, interference with vehicle components may cause tire damage.

WARNING: FAILURE TO EQUIP THE VEHICLE WITH TIRES HAVING ADEQUATE SPEED CAPABILITY CAN RESULT IN SUDDEN TIRE FAILURE.

DIAGNOSIS AND TESTING

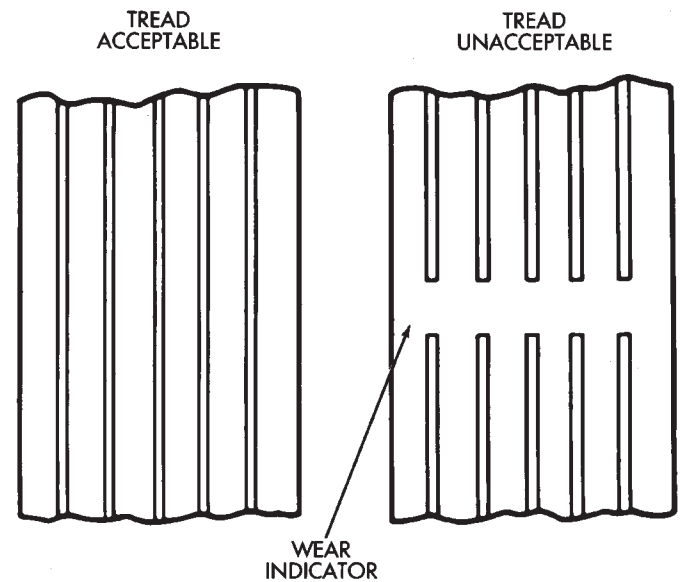
PRESSURE GAUGES

A quality air pressure gauge is recommended to check tire pressure. After checking the air pressure, replace valve cap finger tight.

TREAD WEAR INDICATORS

Tread wear indicators are molded into the bottom of the tread grooves. When tread depth is 1.6 mm (1/16 in.), the tread wear indicators will appear as a 13 mm (1/2 in.) band (Fig. 4).

Tire replacement is necessary when indicators appear in two or more grooves or if localized balding occurs.



J8922-5



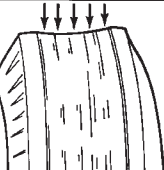
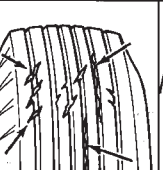
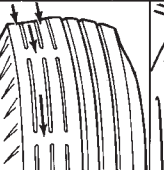
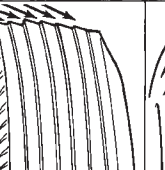

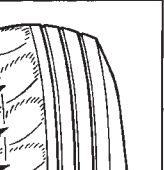
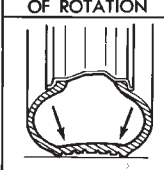
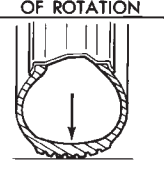
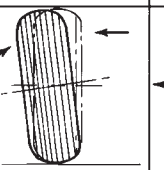
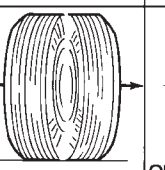
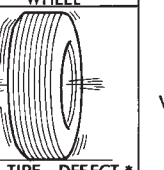
Fig. 4 Tread Wear Indicators

TIRE WEAR PATTERNS

Under inflation will cause wear on the shoulders of tire. Over inflation will cause wear at the center of tire.

Excessive camber causes the tire to run at an angle to the road. One side of tread is then worn more than the other (Fig. 5).

DIAGNOSIS AND TESTING (Continued)

CONDITION	RAPID WEAR AT SHOULDERS	RAPID WEAR AT CENTER	CRACKED TREADS	WEAR ON ONE SIDE	FEATHERED EDGE	BALD SPOTS	SCALLOPED WEAR
EFFECT	 						
CAUSE	UNDER-INFLATION OR LACK OF ROTATION 	OVER-INFLATION OR LACK OF ROTATION 	UNDER-INFLATION OR EXCESSIVE SPEED*	EXCESSIVE CAMBER 	INCORRECT TOE 	UNBALANCED WHEEL 	LACK OF ROTATION OF TIRES OR WORN OR OUT-OF-ALIGNMENT SUSPENSION.
CORRECTION	ADJUST PRESSURE TO SPECIFICATIONS WHEN TIRES ARE COOL ROTATE TIRES			ADJUST CAMBER TO SPECIFICATIONS	ADJUST TOE-IN TO SPECIFICATIONS	DYNAMIC OR STATIC BALANCE WHEELS	ROTATE TIRES AND INSPECT SUSPENSION SEE GROUP 2

*HAVE TIRE INSPECTED FOR FURTHER USE.

RN797

Fig. 5 Tire Wear Patterns

Excessive toe-in or toe-out causes wear on the tread edges and a feathered effect across the tread (Fig. 5).

TIRE NOISE OR VIBRATION

Radial-ply tires are sensitive to force impulses caused by improper mounting, vibration, wheel defects, or possibly tire imbalance.

To find out if tires are causing the noise or vibration, drive the vehicle over a smooth road at varying speeds. Note the noise level during acceleration, deceleration and slight left and right steering inputs.

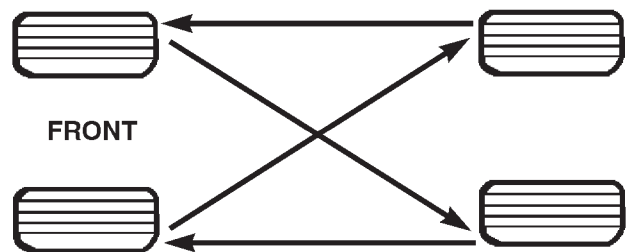


Fig. 6 Tire Rotation Pattern

8031e864

SERVICE PROCEDURES

ROTATION

Tires on the front and rear operate at different loads and perform different steering, driving, and braking functions. For these reasons they wear at unequal rates and tend to develop irregular wear patterns. These effects can be reduced by rotating the tires at regular intervals. The benefits of tire rotation are:

- Increase tread life
- Maintain traction levels
- A smooth, quiet ride

The suggested method of tire rotation is (Fig. 6). Other rotation methods can be used, but they will not provide all the tire longevity benefits.

MATCH MOUNTING

Tires and wheels are currently match mounted at the factory. Match mounting is a technique used to reduce runout in the wheel/tire assembly. This means that the high spot of the tire is aligned with the low

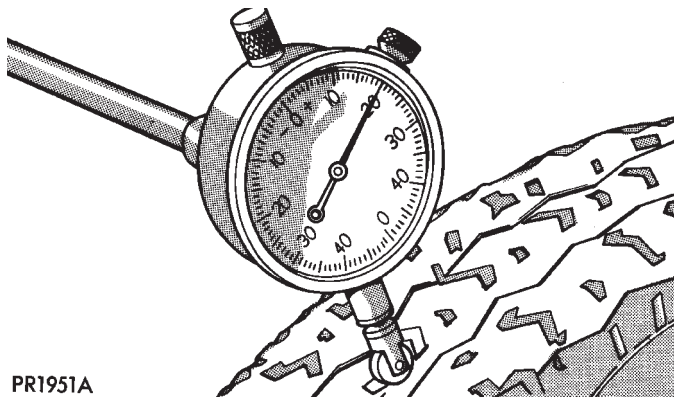
spot on the wheel rim. The high spot on the tire is marked with a paint mark or a bright colored adhesive label on the outboard sidewall. The low spot on the rim is identified with a label on the outside of the rim and a dot on the inside of the rim. If the outside label has been removed the tire will have to be removed to locate the dot on the inside of the rim.

Before dismounting a tire from its wheel, a reference mark should be placed on the tire at the valve stem location. This reference will ensure that it is remounted in the original position on the wheel.

(1) Use a dial indicator to locate the high spot of the tire on the center tread rib (Fig. 7). Record the indicator reading and mark the high spot on the tire. Place a mark on the tire at the valve stem location (Fig. 8).

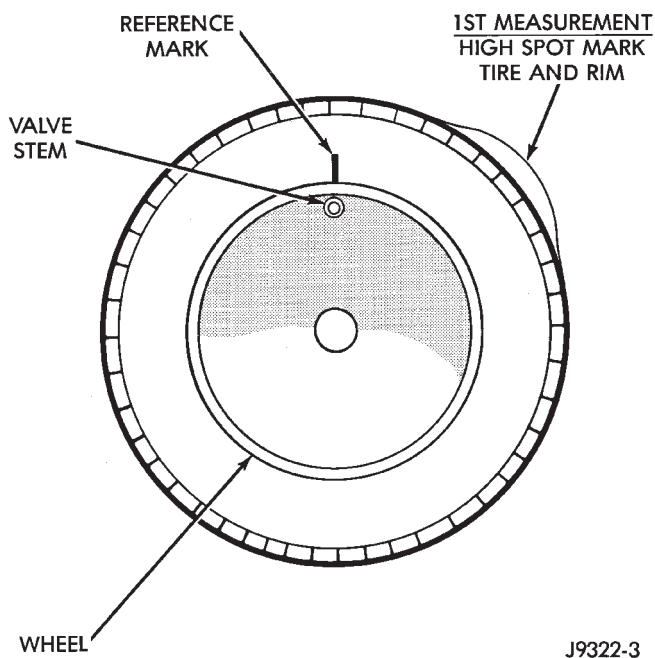
(2) Break down the tire and remount it 180 degrees on the rim (Fig. 9).

SERVICE PROCEDURES (Continued)



PR1951A

Fig. 7 Dial Indicator



J9322-3

Fig. 8 First Measurement On Tire

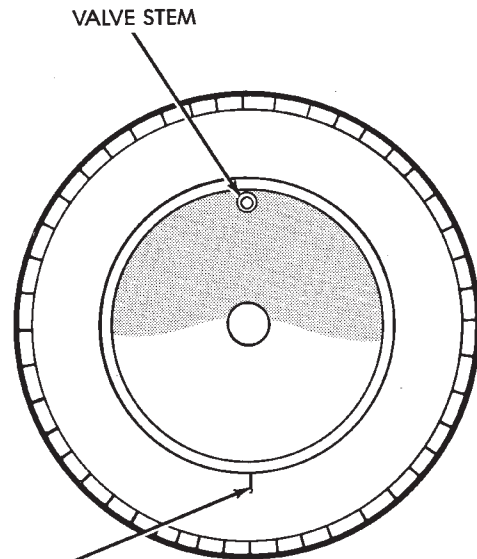
(3) Measure the total runout again and mark the tire to indicate the high spot.

(4) If runout is still excessive use the following procedures.

(a) If the high spot is within 101.6 mm (4.0 in.) of the first spot and is still excessive, replace the tire.

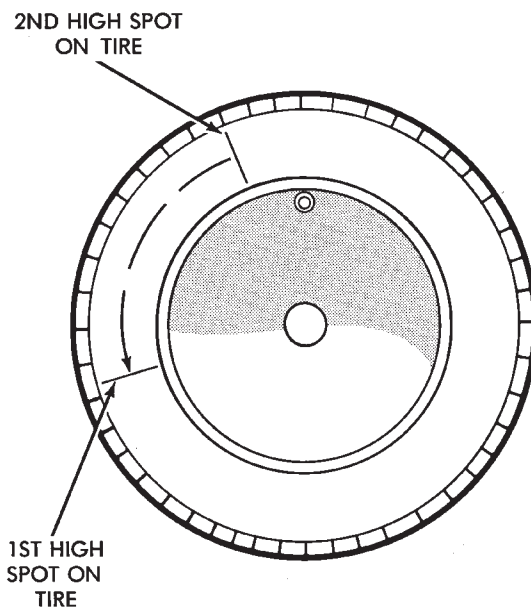
(b) If the high spot is within 101.6 mm (4.0 in.) of the first spot on the wheel, the wheel may be out of specifications. Refer to Wheel and Tire Runout.

(c) If the high spot is NOT within 101.6 mm (4.0 in.) of either high spot, draw an arrow on the tread from second high spot to first. Break down the tire and remount it 90 degrees on rim in that direction (Fig. 10). This procedure will normally reduce the runout to an acceptable amount.



J9322-4

Fig. 9 Remount Tire 180 Degrees



J9322-5

Fig. 10 Remount Tire 90 Degrees In Direction of Arrow

REPAIRING LEAKS

For proper repairing, a radial tire must be removed from the wheel. Repairs should only be made if the defect, or puncture, is in the tread area (Fig. 11). The tire should be replaced if the puncture is located in the sidewall.

Deflate tire completely before removing the tire from the wheel. Use lubrication such as a mild soap solution when dismounting or mounting tire. Use

SERVICE PROCEDURES (Continued)

tools free of burrs or sharp edges which could damage the tire or wheel rim.

Before mounting tire on wheel, make sure all rust is removed from the rim bead and repaint if necessary.

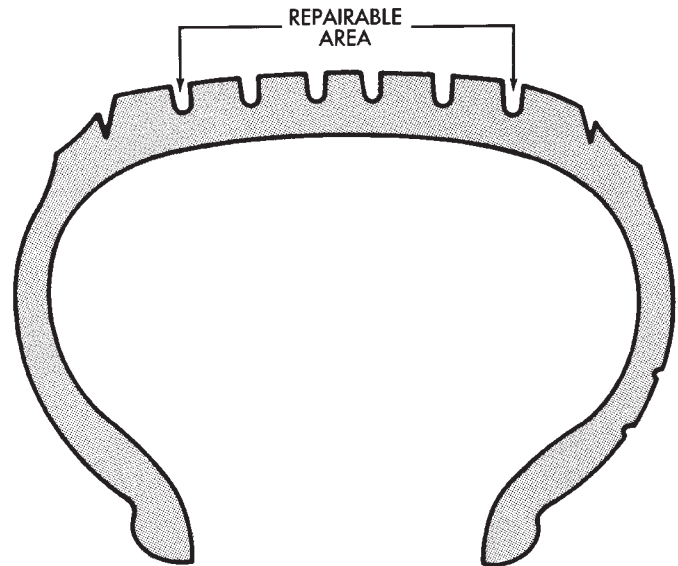
Install wheel on vehicle, and tighten to proper torque specification.

CLEANING AND INSPECTION**CLEANING TIRES**

Remove protective coating on tires before delivery of vehicle. This coating may cause deterioration of tires.

To remove the protective coating applying warm water and let it soak for a few minutes. Then scrub the coating away with a soft bristle brush. Steam cleaning may also be used to remove the coating.

NOTE: DO NOT use gasoline, mineral oil, oil-based solvent or wire brush for cleaning.



J8922-6

Fig. 11 Tire Repair Area

WHEELS

INDEX

	page		page
DESCRIPTION AND OPERATION		SERVICE PROCEDURES	
WHEEL	7	TIRE AND WHEEL BALANCE	9
DIAGNOSIS AND TESTING		WHEEL INSTALLATION	8
TIRE AND WHEEL RUNOUT	7	SPECIFICATIONS	
WHEEL INSPECTION	7	TORQUE CHART	10

DESCRIPTION AND OPERATION

WHEEL

The rim size is on the vehicle safety certification label located on the drivers door shut face. The size of the rim is determined by the drivetrain package. Original equipment wheels/rims are designed for operation up to the specified maximum vehicle capacity.

All models use steel or cast aluminum wheels. Every wheel has raised sections between the rim flanges and rim drop well called safety humps (Fig. 1).

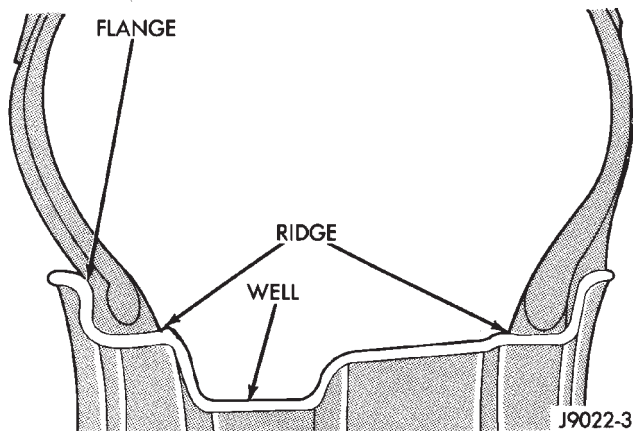


Fig. 1 Safety Rim

Initial inflation of the tire forces the bead over these raised sections. In case of rapid loss of air pressure, the raised sections help hold the tire on the wheel.

The wheel studs and nuts are designed for specific applications. All aluminum and some steel wheels have wheel stud nuts with an enlarged nose. This enlarged nose is necessary to ensure proper retention of the wheels. Do not use replacement studs or nuts with a different design or lesser quality.

DIAGNOSIS AND TESTING

WHEEL INSPECTION

Inspect wheels for:

- Excessive run out
- Dents or cracks
- Damaged wheel lug nut holes
- Air Leaks from any area or surface of the rim

NOTE: Do not attempt to repair a wheel by hammering, heating or welding.

If a wheel is damaged an original equipment replacement wheel should be used. When obtaining replacement wheels, they should be equivalent in load carrying capacity. The diameter, width, offset, pilot hole and bolt circle of the wheel should be the same as the original wheel.

WARNING: FAILURE TO USE EQUIVALENT REPLACEMENT WHEELS MAY ADVERSELY AFFECT THE SAFETY AND HANDLING OF THE VEHICLE. USED WHEELS ARE NOT RECOMMENDED. THE SERVICE HISTORY OF THE WHEEL MAY HAVE INCLUDED SEVERE TREATMENT OR VERY HIGH MILEAGE. THE RIM COULD FAIL WITHOUT WARNING.

TIRE AND WHEEL RUNOUT

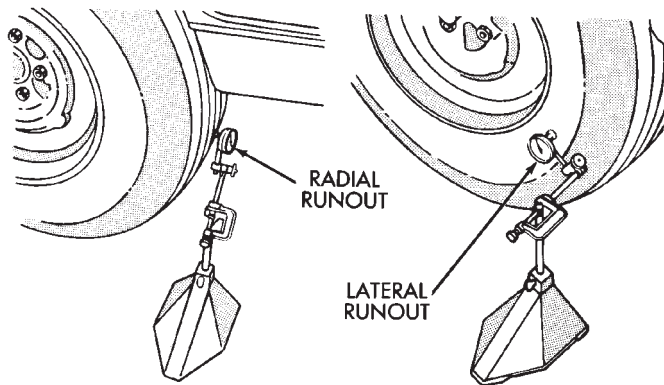
Radial runout is the difference between the high and low points on the tire or wheel (Fig. 2).

Lateral runout is the **wobble** of the tire or wheel.

Radial runout of more than 1.5 mm (.060 inch) measured at the center line of the tread may cause the vehicle to shake.

Lateral runout of more than 2.0 mm (.080 inch) measured near the shoulder of the tire may cause the vehicle to shake.

Sometimes radial runout can be reduced. Relocate the wheel and tire assembly on the mounting studs (See Method 1). If this does not reduce runout to an

DIAGNOSIS AND TESTING (Continued)

J9022-4

Fig. 2 Checking Tire/Wheel/Hub Runout

acceptable level, the tire can be rotated on the wheel. (See Method 2).

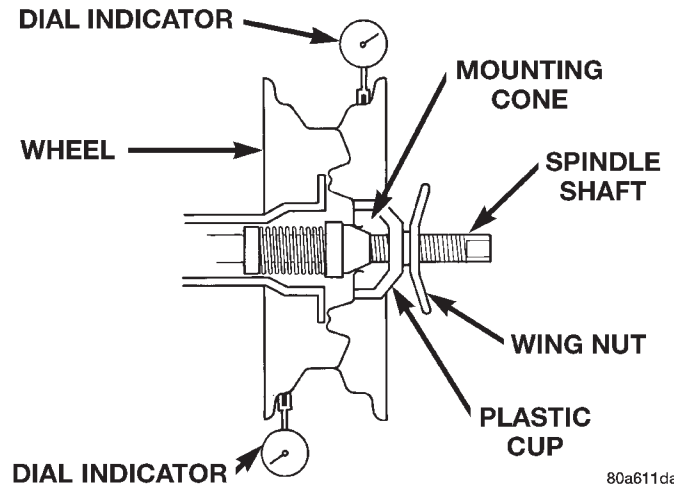
METHOD 1 (RELOCATE WHEEL ON HUB)

- (1) Drive vehicle a short distance to eliminate tire flat spotting from a parked position.
- (2) Check wheel bearings and adjust if adjustable or replace if necessary.
- (3) Check the wheel mounting surface.
- (4) Relocate wheel on the mounting, two studs over from the original position.
- (5) Tighten wheel nuts until all are properly torqued, to eliminate brake distortion.
- (6) Check radial runout. If still excessive, mark tire sidewall, wheel, and stud at point of maximum runout and proceed to Method 2.

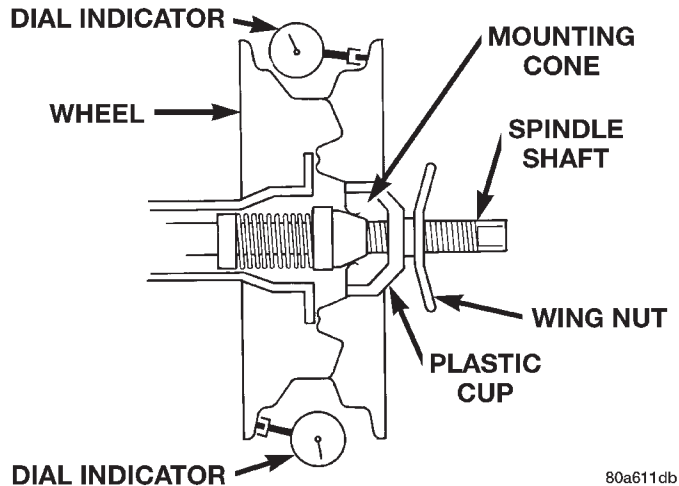
METHOD 2 (RELOCATE TIRE ON WHEEL)

NOTE: Rotating the tire on wheel is particularly effective when there is runout in both tire and wheel.

- (1) Remove tire from wheel and mount wheel on service dynamic balance machine.
- (2) Check wheel radial runout (Fig. 3) and lateral runout (Fig. 4).
 - STEEL WHEELS: Radial runout 0.040 in., Lateral runout 0.045 in.
 - ALUMINUM WHEELS: Radial runout 0.030 in., Lateral runout 0.035 in.
- (3) If point of greatest wheel lateral runout is near original chalk mark, remount tire 180 degrees. Recheck runout, Refer to match mounting procedure.



80a611da

Fig. 3 Radial Runout

80a611db

Fig. 4 Lateral Runout**SERVICE PROCEDURES****WHEEL INSTALLATION**

The wheel studs and nuts are designed for specific applications. They must be replaced with equivalent parts. Do not use replacement parts of lesser quality or a substitute design. All aluminum and some steel wheels have wheel stud nuts which feature an enlarged nose. This enlarged nose is necessary to ensure proper retention of the aluminum wheels.

NOTE: Do not use chrome plated lug nuts with chrome plated wheels.

Before installing the wheel, be sure to remove any build up of corrosion on the wheel mounting surfaces. Ensure wheels are installed with good metal-to-metal contact. Improper installation could cause loosening of wheel nuts. This could affect the safety and handling of your vehicle.

To install the wheel, first position it properly on the mounting surface. All wheel nuts should then be

SERVICE PROCEDURES (Continued)

tightened just snug. Gradually tighten them in sequence to the proper torque specification (Fig. 5). **Never use oil or grease on studs or nuts.**

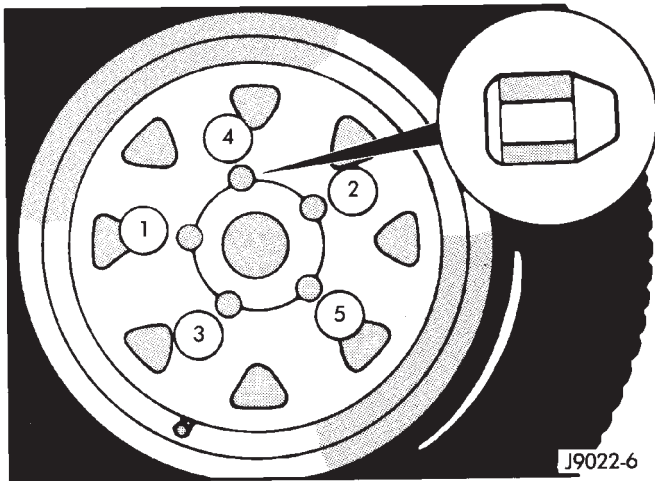


Fig. 5 Lug Nut Tightening Pattern

WHEEL REPLACEMENT

Wheels must be replaced if they have:

- Excessive runout
- Bent or dented
- Leak air through welds
- Have damaged bolt holes

Wheel repairs employing hammering, heating, or welding are not allowed.

Original equipment wheels are available through your dealer. Replacement wheels from any other source should be equivalent in:

- Load carrying capacity
- Diameter

- Width
- Offset
- Mounting configuration

Failure to use equivalent replacement wheels may affect the safety and handling of your vehicle. Replacement with **used** wheels is not recommended. Their service history may have included severe treatment.

TIRE AND WHEEL BALANCE

It is recommended that a two plane service dynamic balancer be used when a tire and wheel assembly require balancing. Refer to balancer operation instructions for proper cone mounting procedures. Typically use front cone mounting method for steel wheels. For aluminum wheel use back cone mounting method without cone spring.

NOTE: Static should be used only when a two plane balancer is not available.

NOTE: Cast aluminum wheels require coated balance weights and special alignment equipment.

Wheel balancing can be accomplished with either on or off vehicle equipment. When using on-vehicle balancing equipment, remove the opposite wheel/tire. Off-vehicle balancing is recommended.

For static balancing, find location of heavy spot causing the imbalance. Counter balance wheel directly opposite the heavy spot. Determine weight required to counter balance the area of imbalance. Place half of this weight on the **inner** rim flange and the other half on the **outer** rim flange (Fig. 6).

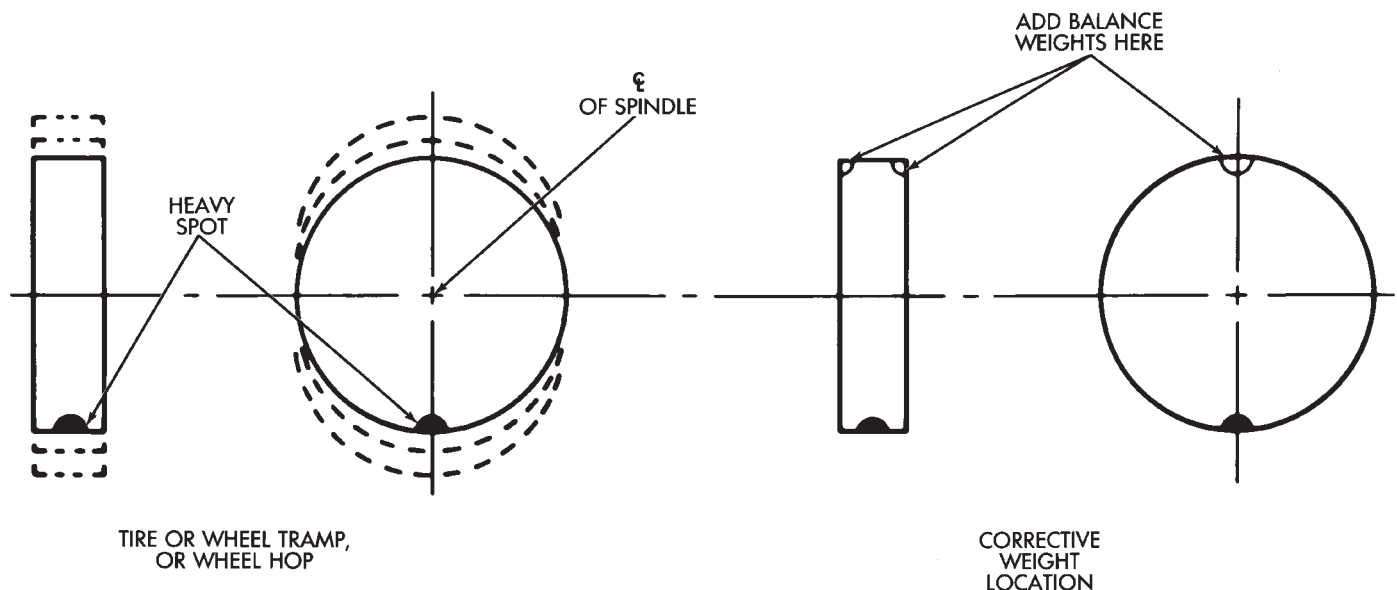
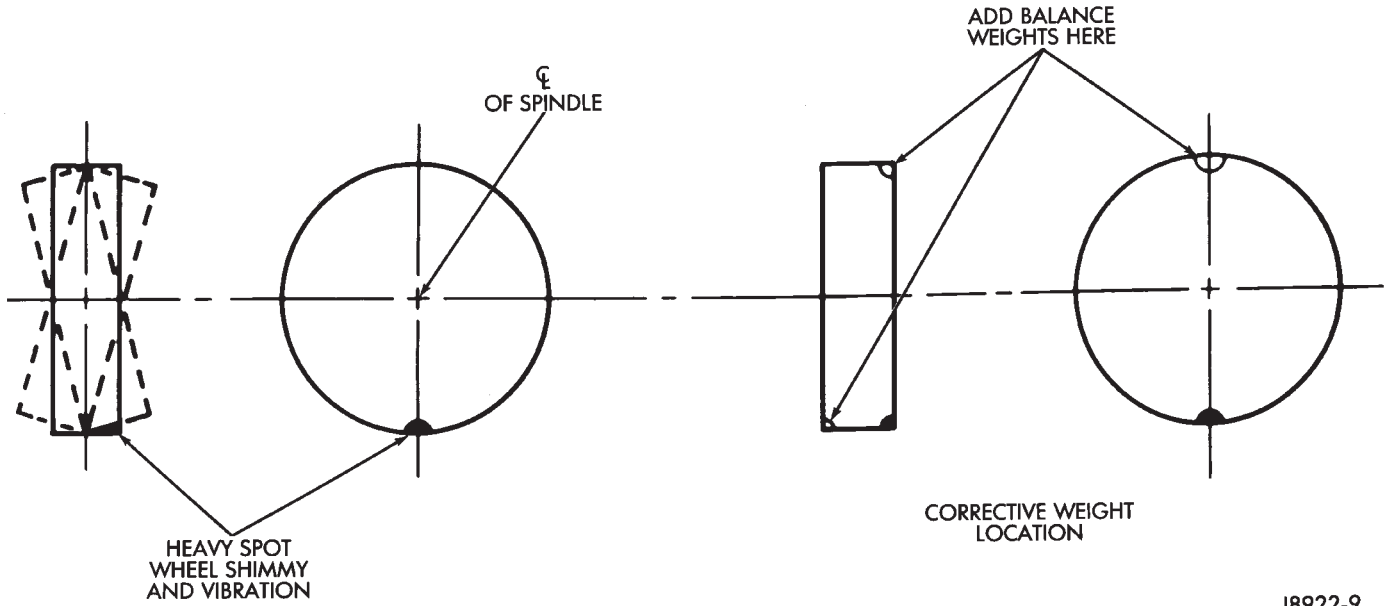


Fig. 6 Static Unbalance & Balance

SERVICE PROCEDURES (Continued)

For dynamic balancing, the balancing equipment is designed to locate the amount of weight to be applied to both the inner and outer rim flange (Fig. 7).



J8922-9

Fig. 7 Dynamic Unbalance & Balance

SPECIFICATIONS

TORQUE CHART

DESCRIPTION	TORQUE
Lug Nut	
1/2 X 20 with 60° Cone	115-150 N·m (85-115 ft. lbs.)

BODY

CONTENTS

	page		page
BODY COMPONENTS	21	POWER SUNROOF	9
GENERAL SERVICE INFORMATION	1	SEATS	17
PAINT	2	STATIONARY GLASS	5

GENERAL SERVICE INFORMATION

INDEX

page

GENERAL INFORMATION
 SAFETY PRECAUTIONS AND WARNINGS 1

GENERAL INFORMATION

SAFETY PRECAUTIONS AND WARNINGS

WARNING: EYE PROTECTION SHOULD BE USED WHEN SERVICING GLASS COMPONENTS. PERSONAL INJURY CAN RESULT.

USE A OSHA APPROVED BREATHING FILTER WHEN SPRAYING PAINT OR SOLVENTS IN A CONFINED AREA. PERSONAL INJURY CAN RESULT.

AVOID PROLONGED SKIN CONTACT WITH PETROLEUM OR ALCOHOL- BASED CLEANING SOLVENTS. PERSONAL INJURY CAN RESULT.

DO NOT STAND UNDER A HOISTED VEHICLE THAT IS NOT PROPERLY SUPPORTED ON SAFETY STANDS. PERSONAL INJURY CAN RESULT.

CAUTION: When holes must be drilled or punched in an inner body panel, verify depth of space to the outer body panel, electrical wiring, or other components. Damage to vehicle can result.

Do not weld exterior panels unless combustible material on the interior of vehicle is removed from the repair area. Fire or hazardous conditions, can result.

Always have a fire extinguisher ready for use when welding.

Disconnect the negative (-) cable clamp from the battery when servicing electrical components that are live when the ignition is OFF. Damage to electrical system can result.

Do not use abrasive chemicals or compounds on painted surfaces. Damage to finish can result.

Do not use harsh alkaline based cleaning solvents on painted or upholstered surfaces. Damage to finish or color can result.

Do not hammer or pound on plastic trim panel when servicing interior trim. Plastic panels can break.

Chrysler Corporation uses many different types of push-in fasteners to secure the interior and exterior trim to the body. Most of these fasteners can be reused to assemble the trim during various repair procedures. At times, a push-in fastener cannot be removed without damaging the fastener or the component it is holding. If it is not possible to remove a fastener without damaging a component or body, cut or break the fastener and use a new one when installing the component. Never pry or pound on a plastic or pressed-board trim component. Using a suitable fork-type prying device, pry the fastener from the retaining hole behind the component being removed. When installing, verify fastener alignment with the retaining hole by hand. Push directly on or over the fastener until it seats. Apply a low-force pull to the panel to verify that it is secure.

When it is necessary to remove components to service another, it should not be necessary to apply excessive force or bend a component to remove it. Before damaging a trim component, verify hidden fasteners or captured edges holding the component in place.

PAINT

INDEX

	page		page
GENERAL INFORMATION		WET SANDING, BUFFING, AND POLISHING	2
BASE COAT/CLEAR COAT FINISH	2	SPECIFICATIONS	
PAINT CODE	2	AFTER MARKET PAINT REPAIR PRODUCTS	3
PAINTED SURFACE TOUCH-UP	2		

GENERAL INFORMATION

PAINT CODE

Exterior vehicle body colors are identified on the Body Code plate. The plate is located on the top, right side of the dash panel below the cowl grille in the engine compartment. Refer to the Introduction section at the front of this manual for body code plate description. The paint code is also identified on the Vehicle Safety Certification Label which is located on the drivers door shut face. The color names provided in the Paint and Trim Code Description chart are the color names used on most repair product containers.

BASE COAT/CLEAR COAT FINISH

On most vehicles a two-part paint application (base coat/clear coat) is used. Color paint that is applied to primer is called base coat. The clear coat protects the base coat from ultraviolet light and provides a durable high-gloss finish.

WET SANDING, BUFFING, AND POLISHING

Minor acid etching, orange peel, or smudging in clear coat or single-stage finishes can be reduced with light wet sanding, hand buffing, and polishing. **If the finish has been wet sanded in the past, it cannot be repeated. Wet sanding operation should be performed by a trained automotive paint technician.**

CAUTION: Do not remove clear coat finish, if equipped. Base coat paint must retain clear coat for durability.

PAINTED SURFACE TOUCH-UP

When a painted metal surface has been scratched or chipped, it should be touched-up as soon as possible to avoid corrosion. For best results, use Mopar® Scratch Filler/Primer, Touch-Up Paints and Clear Top Coat. Refer to Introduction group of this manual for Body Code Plate information.

TOUCH-UP PROCEDURE

- (1) Scrape loose paint and corrosion from inside scratch or chip.
- (2) Clean affected area with Mopar® Tar/Road Oil Remover, and allow to dry.
- (3) Fill the inside of the scratch or chip with a coat of filler/primer. Do not overlap primer onto good surface finish. The applicator brush should be wet enough to puddle-fill the defect without running. Do not stroke brush applicator on body surface. Allow the filler/primer to dry hard.
- (4) Cover the filler/primer with color touch-up paint. Do not overlap touch-up color onto the original color coat around the scratch or chip. Butt the new color to the original color, if possible. Do not stroke applicator brush on body surface. Allow touch-up paint to dry hard.
- (5) On vehicles without clear coat, the touch-up color can be lightly wet sanded (1500 grit) and polished with rubbing compound.
- (6) On vehicles with clear coat, apply clear top coat to touch-up paint with the same technique as described in Step 4. Allow clear top coat to dry hard. If desired, Step 5 can be performed on clear top coat.

SPECIFICATIONS

AFTER MARKET PAINT REPAIR PRODUCTS

EXTERIOR COLOR

EXTERIOR COLOR	CHRY CODE *	PPG	BASF	DuPONT	SHERWIN-WILLIAMS	AKZO NOBEL SIKKENS
Dark Rosewood Pearl Coat	REG	27558	25041	B9519	50266	CHA95:REG
Flame Red Clear Coat	PR4	4679	23043	B9326	46916	CHA93:PR4
Deep Slate Pearl Coat	VAW	5292	27166	B9774	54118	CHA97:VAW
Char Gold II Satin Glow	RJ7	35748	25037	B9532	50278	CHA95:RJ7
Light Driftwood Satin Glow	MFA	4569	22110	B9623	46579	CHA92:MFA
Forest Green Pearl Coat	SG8	47439	26078	B9609	51062	CHA95:SG8
Deep Amethyst Pearl Coat	TCN	5246	27038	B9736	52026	CHA97:TCN
Bright Metallic Clear Coat	MS4	4820	24082	B9642	48823	CHA94:MS4
Black Clear Coat	DX8	9700	15214	99	34858 90-5950	CHA85:DX8
Taupe Frost Pearl Coat	TTK	5244	27040	B9750	52567	CHA97:TTK
Stone White Clear Coat	SW1	83542	26089	B9622	51540	CHA96:SW1

SPECIFICATIONS (Continued)**CLADDING COLOR**

CLADDING COLOR	CHRY CODE *	PPG	BASF	DuPONT	SHERWIN-WILLIAMS	AKZO NOBEL SIKKENS
Flame Red	PR4	4679	23043	B9326	46916	CHAPR4M
Medium Driftwood	MFD	27360	23054	C9321	48024	CHA93:MFD
Dark Rosewood	REG	4966	25041	B9519	50266	CHAREGM
Deep Hunter Green	SG8	47439	26078	B9609	51062	CHASG8M
Deep Amethyst	TCN	5246	27038	B9736	52026	CHA97:TCN
Black	DX8	9700	15214	F0204	34858 90-5950	CHADX8M
Dark Neutral Gray	HS5	34349	20215	C8923	40392	CHA90:HS5
Deep Slate	VAW	5292	27166	B9774	54118	CHA97:VAW
Bright Platinum	MS4	4820	24082	B9462	48823	CHAMS4M
Char Gold II Satin Glow	RJ7	4975	25037	B9532	50278	CHA95:RJ7
Taupe Frost	TTK	5244	27040	B9750	52567	CHA97:TTK
Stone White	SW1	83542	26089	B9622	51539	CHASW1M

NOTE: *Herberts Standox and Spies Hecker use the Chrysler paint code as listed on the Body Code Plate and the Vehicle Safety Certification label.

INTERIOR COLOR

INTERIOR COLOR	CHRY CODE	PPG	BASF	DuPONT	SHERWIN-WILLIAMS	AKZO NOBEL SIKKENS
Agate	AZ	9856/2-1461	22135	C9208	45994	CHALAZI
Mist Gray	C3	35799/2-1576	25065	C9507	50508	CHARC3I
Saddle	T6	27917/2-1594	26121	C9603	51541	CHART6I
Saddle/ Moss Green (RT6/RJ4)	TJ	N/A	26121 25069	C9604 C9513	51542 50512	CHART6I/ CHARJ4I

STATIONARY GLASS

INDEX

	page		page
DESCRIPTION AND OPERATION		QUARTER WINDOW GLASS	7
SAFETY PRECAUTIONS	5	WINDSHIELD	5
REMOVAL AND INSTALLATION			
LIFTGATE GLASS	8		

DESCRIPTION AND OPERATION

SAFETY PRECAUTIONS

WARNING: DO NOT OPERATE THE VEHICLE WITHIN 24 HOURS OF WINDSHIELD INSTALLATION. IT TAKES AT LEAST 24 HOURS FOR URETHANE ADHESIVE TO CURE. IF IT IS NOT CURED, THE WINDSHIELD MAY NOT PERFORM PROPERLY IN AN ACCIDENT.

URETHANE ADHESIVES ARE APPLIED AS A SYSTEM. USE GLASS CLEANER, GLASS PREP SOLVENT, GLASS PRIMER, PVC (VINYL) PRIMER AND PINCHWELD (FENCE) PRIMER PROVIDED BY THE ADHESIVE MANUFACTURER. IF NOT, STRUCTURAL INTEGRITY COULD BE COMPROMISED.

CHRYSLER DOES NOT RECOMMEND GLASS ADHESIVE BY BRAND. TECHNICIANS SHOULD REVIEW PRODUCT LABELS AND TECHNICAL DATA SHEETS, AND USE ONLY ADHESIVES THAT THEIR MANUFACTURERS WARRANT WILL RESTORE A VEHICLE TO THE REQUIREMENTS OF FMVSS 212. TECHNICIANS SHOULD ALSO INSURE THAT PRIMERS AND CLEANERS ARE COMPATIBLE WITH THE PARTICULAR ADHESIVE USED.

BE SURE TO REFER TO THE URETHANE MANUFACTURER'S DIRECTIONS FOR CURING TIME SPECIFICATIONS, AND DO NOT USE ADHESIVE AFTER ITS EXPIRATION DATE.

VAPORS THAT ARE EMITTED FROM THE URETHANE ADHESIVE OR PRIMER COULD CAUSE PERSONAL INJURY. USE THEM IN A WELL-VENTILATED AREA.

SKIN CONTACT WITH URETHANE ADHESIVE SHOULD BE AVOIDED. PERSONAL INJURY MAY RESULT.

ALWAYS WEAR EYE AND HAND PROTECTION WHEN WORKING WITH GLASS.

CAUTION: Protect all painted and trimmed surfaces from coming in contact with urethane or primers.

Be careful not to damage painted surfaces when removing moldings or cutting urethane around windshield.

It is difficult to salvage a windshield during the removal operation. The windshield is part of the structural support for the roof. The urethane bonding used to secure the windshield to the fence is difficult to cut or clean from any surface. If the moldings are set in urethane, it would also be unlikely they could be salvaged. Before removing the windshield, check the availability of the windshield and moldings from the parts supplier.

REMOVAL AND INSTALLATION

WINDSHIELD

REMOVAL

- (1) Remove inside rear view mirror.
- (2) Remove cowl cover.
- (3) Remove screws attaching windshield side molding to A-pillar (Fig. 1).
- (4) Remove upper windshield molding.
- (5) Cut urethane bonding from around windshield using a suitable sharp cold knife. A pneumatic cutting device can be used if available (Fig. 2).
- (6) Separate windshield from vehicle.

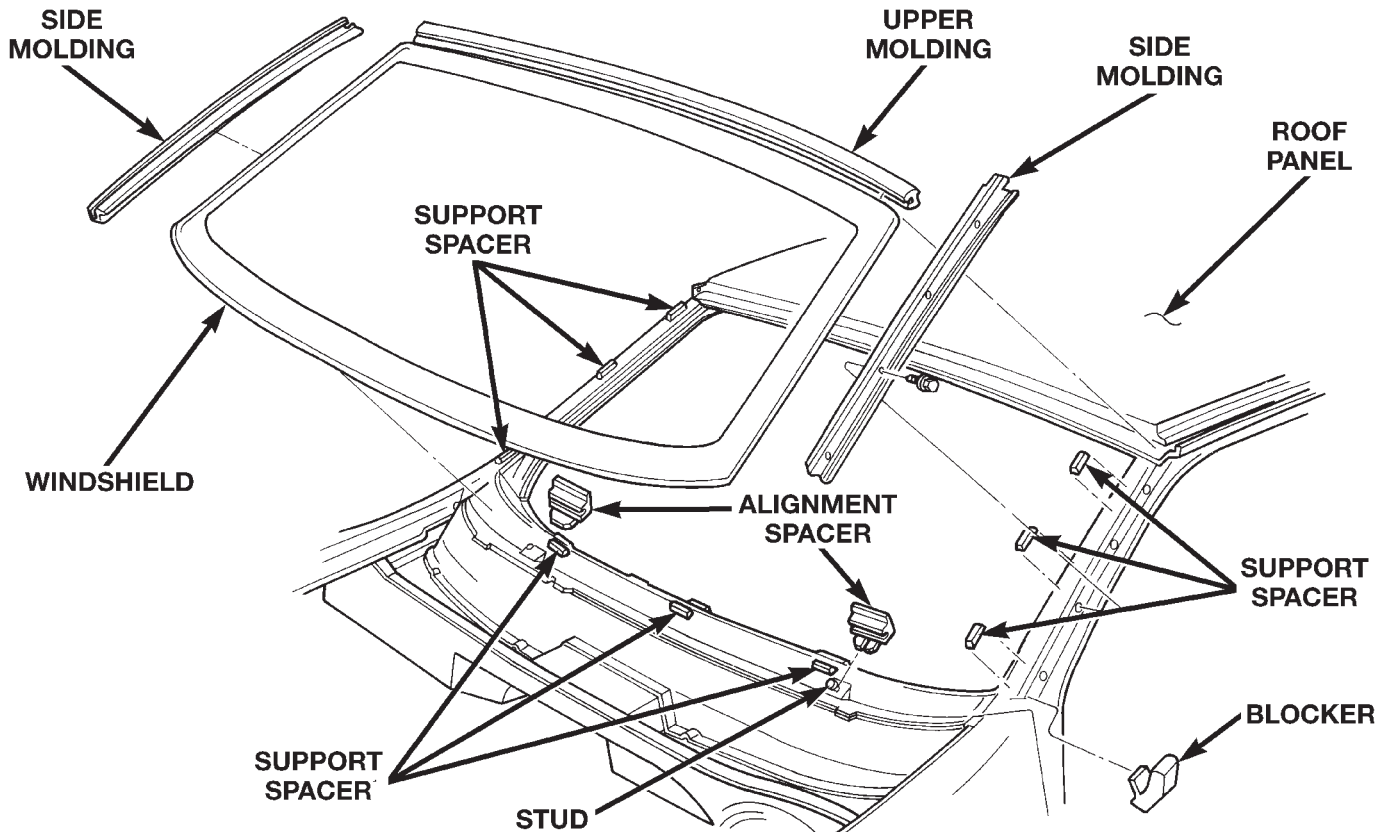
INSTALLATION

WARNING: REVIEW ALL WARNINGS AND CAUTIONS IN THIS GROUP BEFORE PRECEDING WITH INSTALLATION.

CAUTION: Open a window before installing windshield. This will avoid pressurizing the passenger compartment. If a door or liftgate is slammed before urethane is cured, water leaks can result.

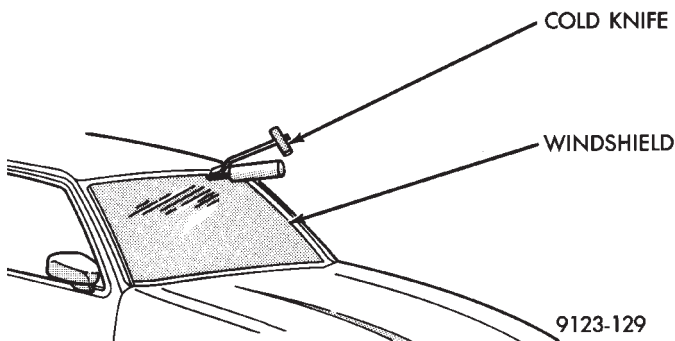
The windshield fence should be cleaned of old urethane bonding material. Support spacers should be

REMOVAL AND INSTALLATION (Continued)



80500535

Fig. 1 Windshield



9123-129

Fig. 2 Cut Urethane Around Windshield—Typical

cleaned and properly installed on weld studs or repair screws at bottom of windshield opening.

(1) Place replacement windshield into windshield opening. Position glass in the center of the opening against the support spacers. Mark the glass at the support spacers with a grease pencil or masking tape and ink pen to use as a reference for installation. Remove replacement windshield from windshield opening (Fig. 3).

(2) Position the windshield inside up on a suitable work surface with two padded, wood 10 cm by 10 cm by 50 cm (4 in. by 4 in. by 20 in.) blocks, placed parallel 75 cm (2.5 ft.) apart (Fig. 4).

(3) Clean inside of windshield with Mopar Glass Cleaner and lint-free cloth.

(4) Apply clear glass primer 25 mm (1 in.) wide around edge of windshield. Wipe with clean/dry lint-free cloth.

(5) Apply black-out primer 15 mm (.75 in.) wide on top and sides of windshield and 25 mm (1 in.) on bottom of windshield. Allow at least three minutes drying time.

(6) Position windshield spacers on lower fence above support spacers at the edge of the windshield opening (Fig. 1).

(7) Apply a 10 mm (0.4 in.) bead of urethane around perimeter of windshield along the inside of the moldings. Apply two beads along the bottom edge.

(8) Install upper molding onto windshield.

(9) Apply fence primer around the perimeter of the windshield opening fence. Allow at least 18 minutes drying time.

(10) With aid of a helper, position windshield over windshield opening. Align reference marks at bottom of windshield to support spacers.

(11) Slowly lower windshield glass to windshield opening fence. Guide top molding into proper position if necessary. Push windshield inward to fence spacers at bottom and until top molding is flush to roof line.

REMOVAL AND INSTALLATION (Continued)

- (12) Clean excess urethane from exterior with Mopar Super Clean or equivalent.
- (13) Install windshield side moldings.
- (14) Install cowl cover and wipers.
- (15) Install inside rear view mirror.
- (16) After urethane has cured, water test windshield to verify repair.

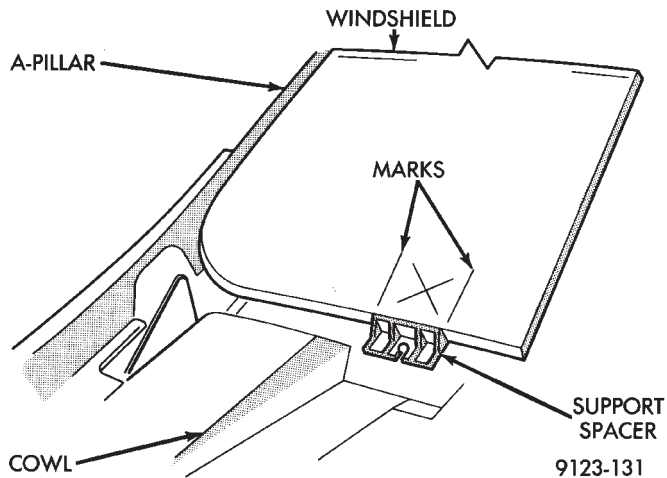


Fig. 3 Center Windshield and Mark at Support Spacers

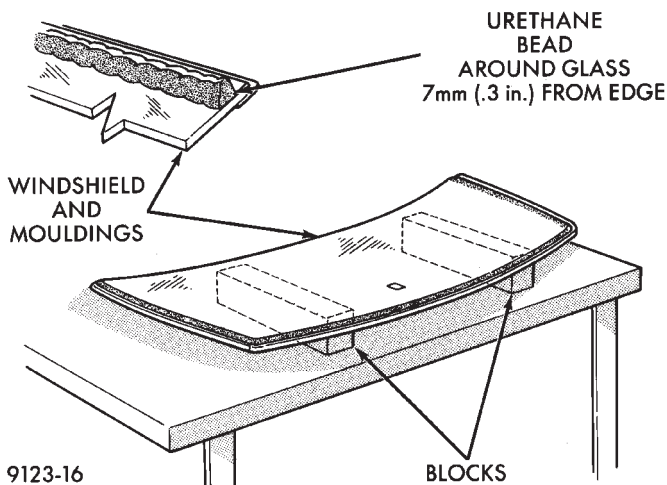


Fig. 4 Work Surface Set up and Molding Installation

QUARTER WINDOW GLASS

REMOVAL

- (1) Cut urethane bonding from around quarter window glass using a suitable sharp cold knife. A pneumatic cutting device can be used if available.
- (2) Separate glass from vehicle.

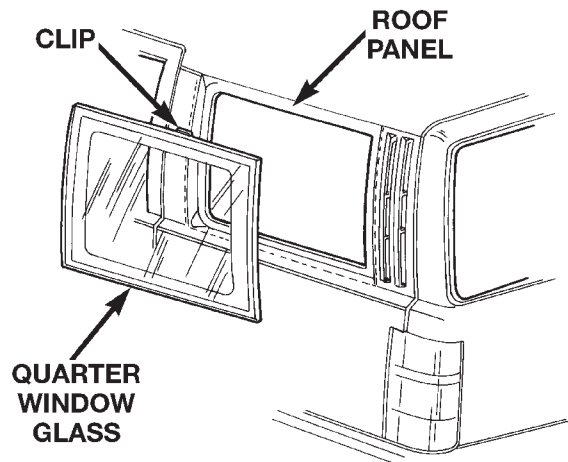
INSTALLATION

CAUTION: Open a window before installing glass. This will avoid pressurizing the passenger compartment. If a door or liftgate is slammed before urethane is cured, water leaks can result.

The window opening fence should be cleaned of old urethane bonding material.

- (1) Clean inside of glass with Mopar Glass Cleaner and lint-free cloth.
- (2) Apply PVC (vinyl) primer 25 mm (1 in.) wide around edge of glass. Wipe with clean/dry lint-free cloth.
- (3) Apply fence primer around edge of fence. Allow at least eighteen minutes drying time.
- (4) Apply a 10 mm (0.4 in.) bead of urethane around window vinyl border location.

Position glass into window opening and lock clips into place (Fig. 5).



804dBede

Fig. 5 Quarter Window Glass

REMOVAL AND INSTALLATION (Continued)**LIFTGATE GLASS****REMOVAL**

(1) Cut urethane bonding from around liftgate glass using a suitable sharp cold knife. A pneumatic cutting device can be used if available.

(2) Separate glass from vehicle.

INSTALLATION

CAUTION: Open a window before installing glass. This will avoid pressurizing the passenger compartment. If a door or liftgate is slammed before urethane is cured, water leaks can result.

The window opening fence should be cleaned of old urethane bonding material.

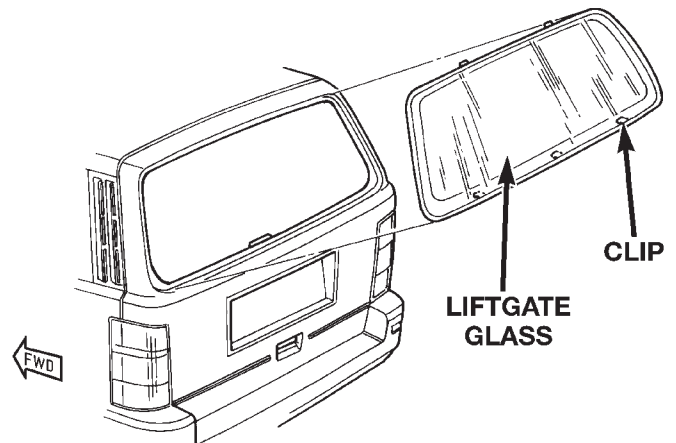
(1) Clean inside of glass with Mopar Glass Cleaner and lint-free cloth.

(2) Apply PVC (vinyl) primer 25 mm (1 in.) wide around edge of glass. Wipe with clean/dry lint-free cloth.

(3) Apply fence primer around edge of fence. Allow at least eighteen minutes drying time.

(4) Apply a 10 mm (0.4 in.) bead of urethane around window vinyl border location.

Position glass into window opening and lock clips into place (Fig. 6).



804d8ee0

Fig. 6 Liftgate Glass

POWER SUNROOF

INDEX

	page		page
GENERAL INFORMATION		GUIDE ASSEMBLY	15
GENERAL INFORMATION	9	MOTOR AND DRIVE GEARS	13
REMOVAL AND INSTALLATION		SUNROOF ADJUSTMENT BRACKET	13
DRAIN CHANNEL	13	SUNSHADE	15
DRAIN TUBE	13	WIND DEFLECTOR	12
DRIVE CABLE LOCATORS	13	ADJUSTMENTS	
DRIVE CABLES	14	GLASS PANEL VERTICAL HEIGHT	
GLASS PANEL	12	ADJUSTMENT	16

GENERAL INFORMATION

GENERAL INFORMATION

All sunroofs are equipped with drain tubes (Fig. 1) and (Fig. 2). The drain tubes must be kept open to prevent water from entering passenger compartment. When servicing separate components, refer to the Sunroof Component view (Fig. 3) for part description.

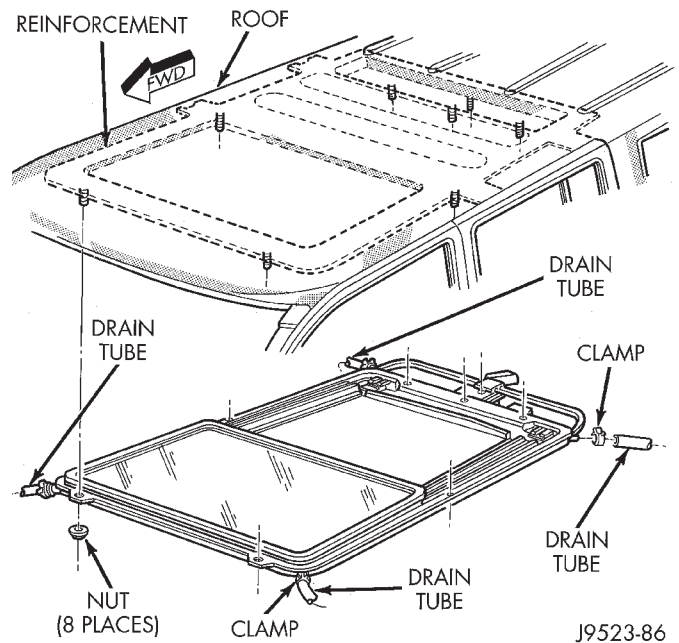


Fig. 1 Drain Tubes

GENERAL INFORMATION (Continued)

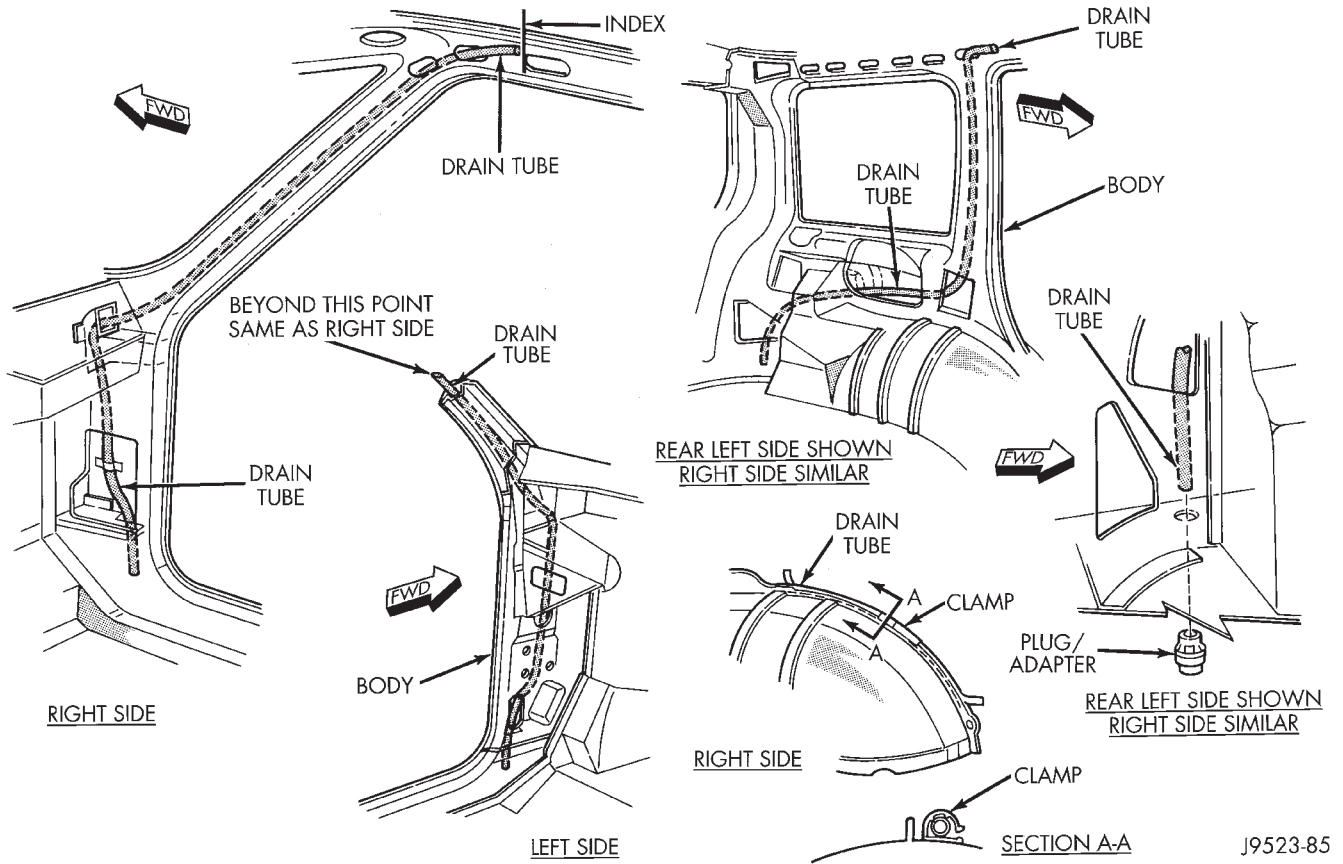


Fig. 2 Drain Tube Locations

GENERAL INFORMATION (Continued)

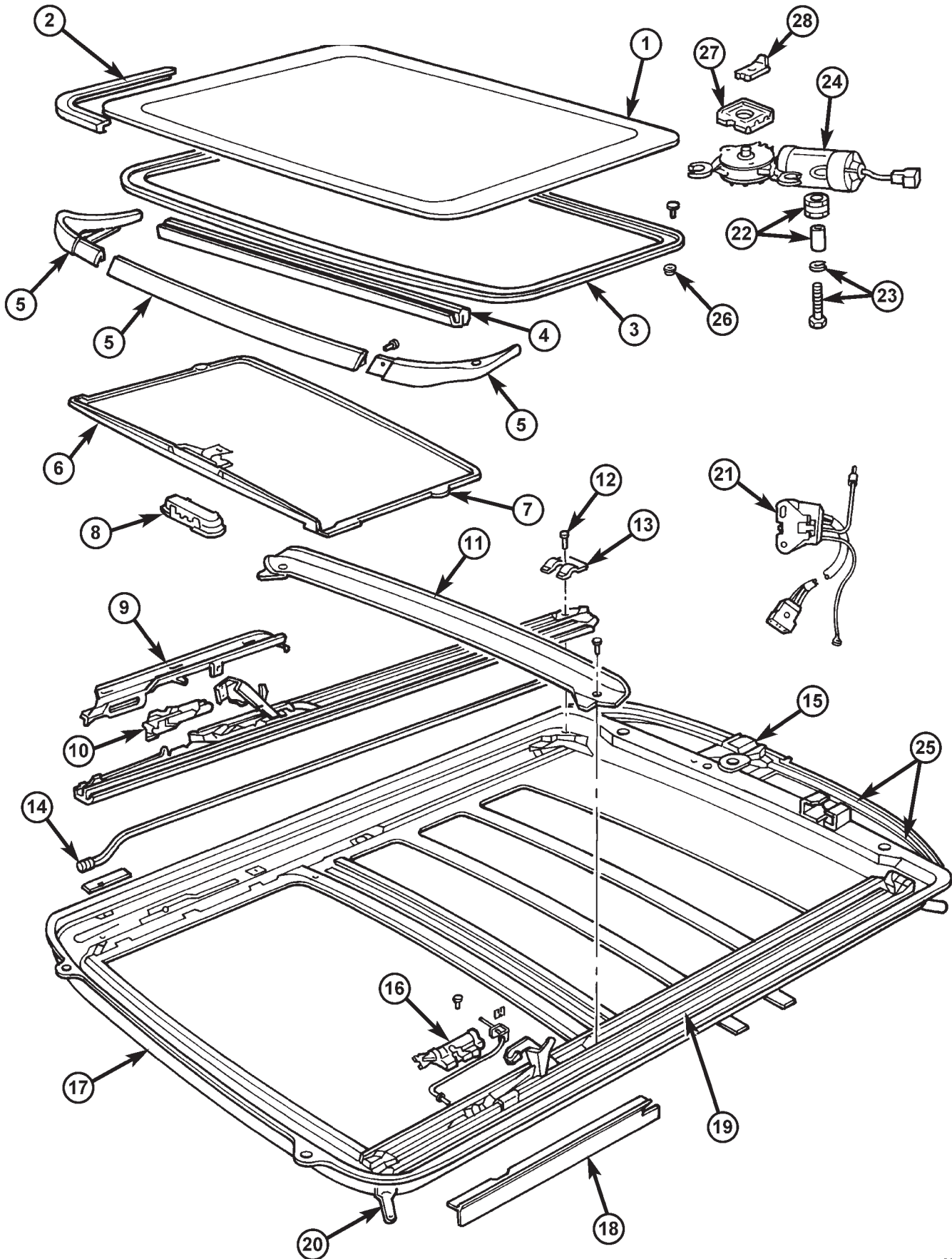


Fig. 3 Sunroof Components

GENERAL INFORMATION (Continued)

Sunroof Components				
1	Glass Panel		15	Cable & Bracket
2	Seal		16	Locator
3	Reinforcement		17	Tray
4	Support		18	Cover
5	Deflector		19	Track (R) or (L)
6	Sunshade		20	Drain Hose
7	Clip		21	Relay
8	Handle		22	Spacer
9	Bracket (R) or (L)		23	Screw & Washer
10	Locator		24	Motor
11	Drain Channel		25	Cables
12	Screw		26	Nut
13	Bracket		27	Bracket
14	Seal		28	Bracket

REMOVAL AND INSTALLATION

WIND DEFLECTOR

REMOVAL

- (1) Open sun roof glass panel.
- (2) Remove screws holding wind deflector to sun roof unit side rail (Fig. 4).
- (3) Separate wind deflector from vehicle.

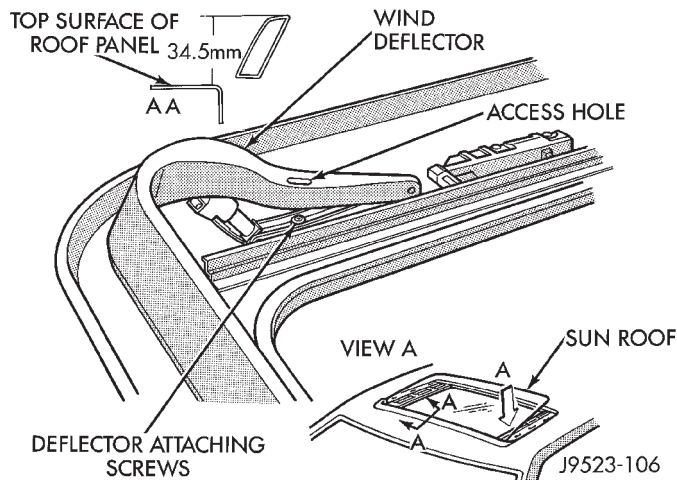


Fig. 4 Deflector Assembly

INSTALLATION

- (1) Reverse preceding operation.

GLASS PANEL

REMOVAL

- (1) Position glass to vent position.
- (2) Remove wind deflector mechanism covers (Fig. 5).
- (3) Position sunshade full rearward.
- (4) Loosen nuts holding glass panel to side adjustment brackets show in View B (Fig. 5).
- (5) Slide glass panel rearward 12mm (0.5in.) and separate glass from sunroof unit.

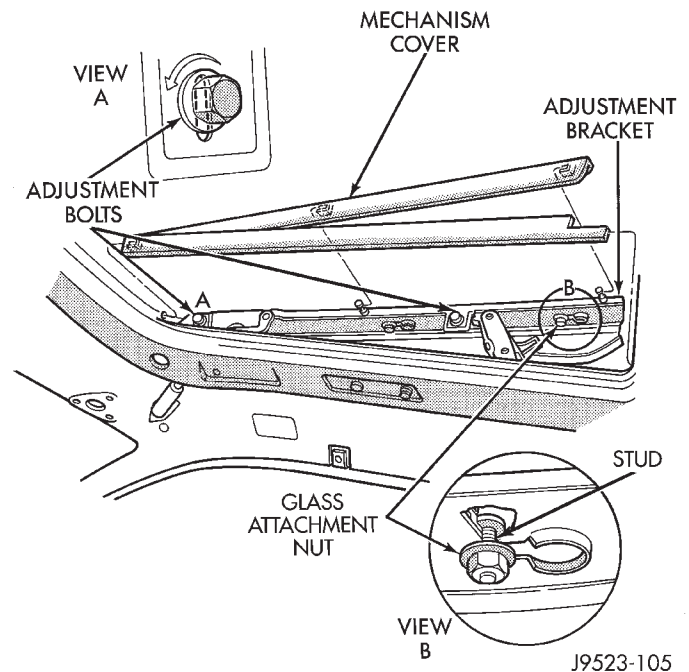


Fig. 5 Glass Adjustment

INSTALLATION

- (1) Position glass panel in opening with logo rearward and slide panel forward 12 mm (0.5in.).
- (2) Verify that attaching nuts are below top surface of glass adjustment brackets.
- (3) Close sunroof to center glass panel in roof opening.

REMOVAL AND INSTALLATION (Continued)

- (4) Tighten center nuts to hold adjustment.
- (5) Open glass to vent position and tighten nuts to 8 N·m (70.8 in. lbs.).
- (6) Close glass and check alignment.
- (7) Locate glass to vent position.
- (8) Install mechanism covers.

SUNROOF ADJUSTMENT BRACKET

REMOVAL

- (1) Remove wind deflector, mechanism covers and glass panel.
- (2) Move glass carriage to vent position and remove rearward adjustment bolt from adjustment bracket.
- (3) Lift rear of adjustment bracket to highest vertical position and disengage front of bracket from unit (Fig. 5).

INSTALLATION

- (1) Reverse the preceding operation. Adjust glass as necessary.

DRAIN CHANNEL

REMOVAL

- (1) Move glass to vent position.
- (2) Remove mechanism covers and glass panel.
- (3) Remove screws holding drain channel to support frame.

INSTALLATION

- (1) Reverse preceding operation.

DRAIN TUBE

REMOVAL

- (1) Remove the headliner to access clamps attaching drain tube to sunroof.
- (2) Disengage clamps attaching drain tube to sunroof (Fig. 6).
- (3) Tape the end of the old drain tube to the new drain tube. Ensure that the tape build up on the tube ends is not excessive.
- (4) Remove front/rear trim panels as necessary to disengage clamps securing drain tube to body (Fig. 7).
- (5) Remove the drain tube plug from the underside of the vehicle.
- (6) From the underside of the vehicle carefully, pull/route the drain tube through the body panel. Applying a soapy water solution to the new tube may aid in this procedure.

INSTALLATION

- (1) Install the plug adapter to the bottom of the drain tube.

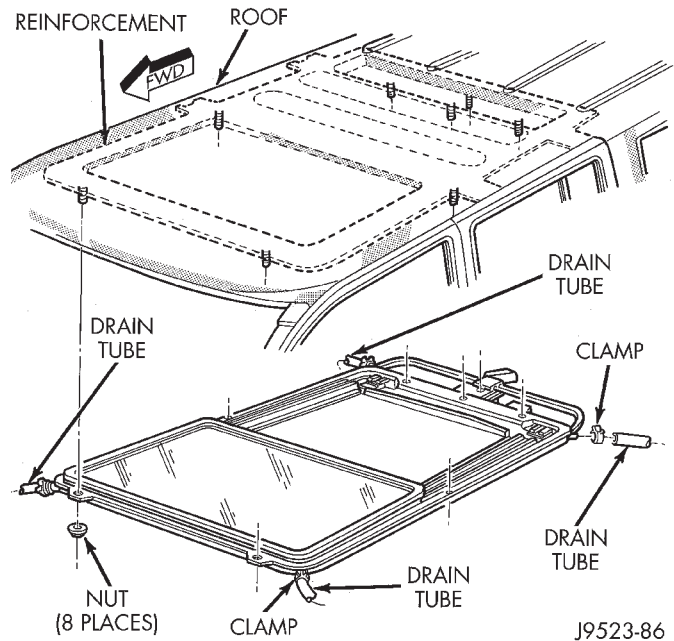


Fig. 6 Drain Tube

- (2) Engage clamps securing drain tube to body.
- (3) Install front/rear trim panels as necessary.
- (4) Install drain tube to sunroof and engage clamp.
- (5) Install the headliner.

DRIVE CABLE LOCATORS

REMOVAL

- (1) Position glass 19 mm (0.75 in.) until rearward cable locator is visible.
- (2) Remove screws holding drive cable locator to unit.
- (3) Remove travel limiting micro switch grommet and disconnect wire connector.
- (4) Insert a small screwdriver under rear edge of locator and pry locator from track (Fig. 8).

INSTALLATION

- (1) Reverse preceding operation. The small out-board lip underneath cable locator slips under bottom slot on guide track. After locator is seated, install screws.

MOTOR AND DRIVE GEARS

REMOVAL

- (1) Open sunroof to vent position.
- (2) Remove headlining.
- (3) Remove bolts holding sunroof motor to motor bracket.
- (4) Disconnect wire connector.
- (5) Separate motor and drive gear from drive cables (Fig. 9).

REMOVAL AND INSTALLATION (Continued)

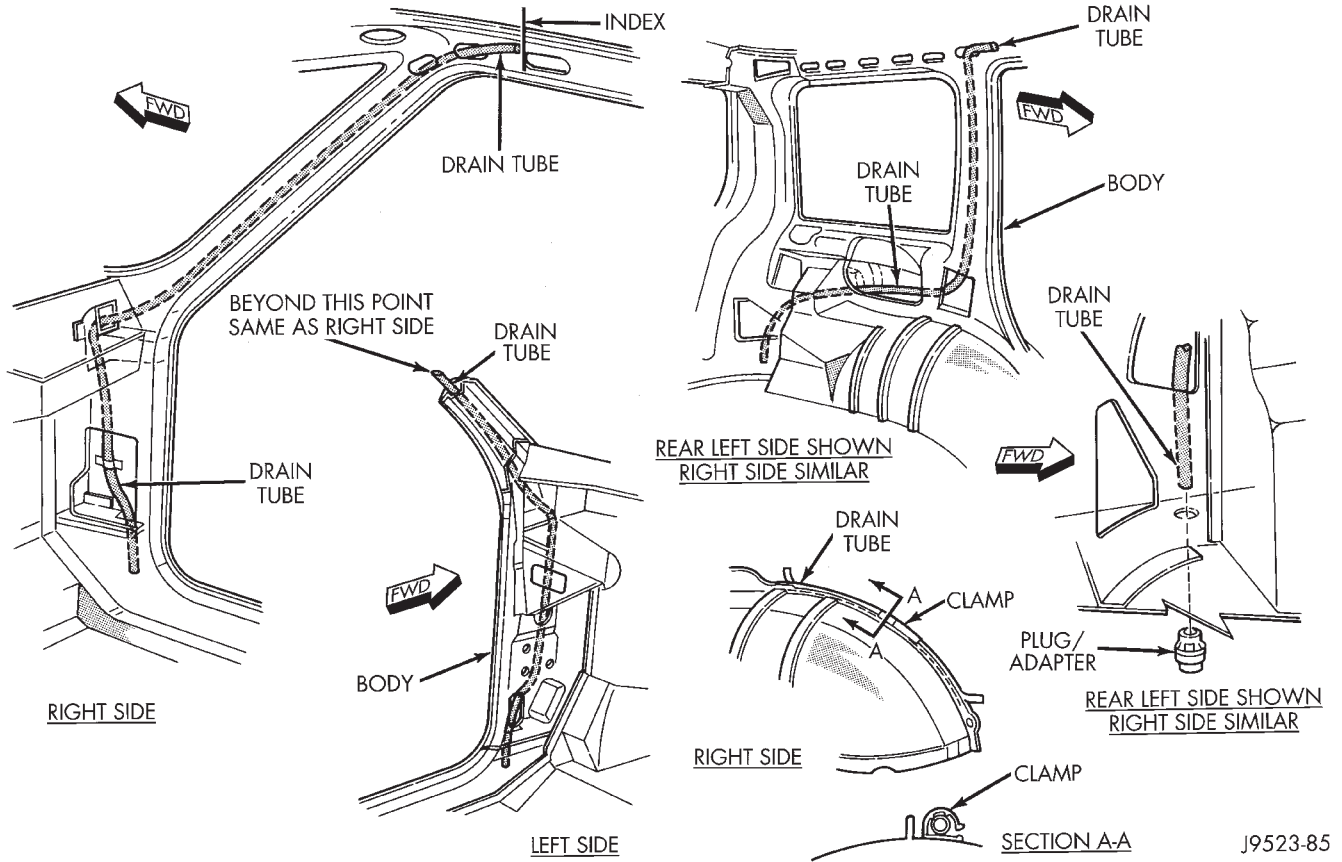


Fig. 7 Drain Tube Clamps

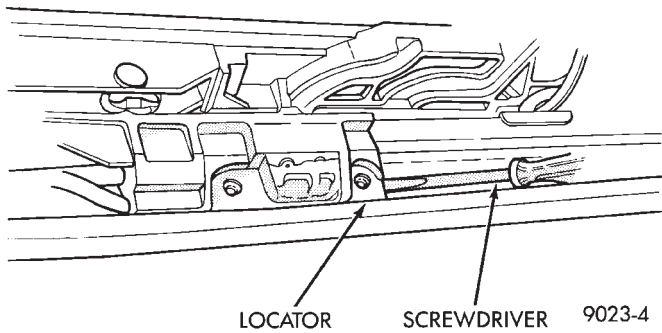


Fig. 8 Removing Cable Drive Locator

INSTALLATION

- (1) Verify that sunroof is in vent position. Push mechanism forward on both sides to align drive cables.
- (2) Engage drive gears onto drive cables.
- (3) Install motor and drive gear screws and tighten to 5 N·m (44in-lbs.).
- (4) Install headlining.

DRIVE CABLES

REMOVAL

- (1) Open sunroof to vent position.

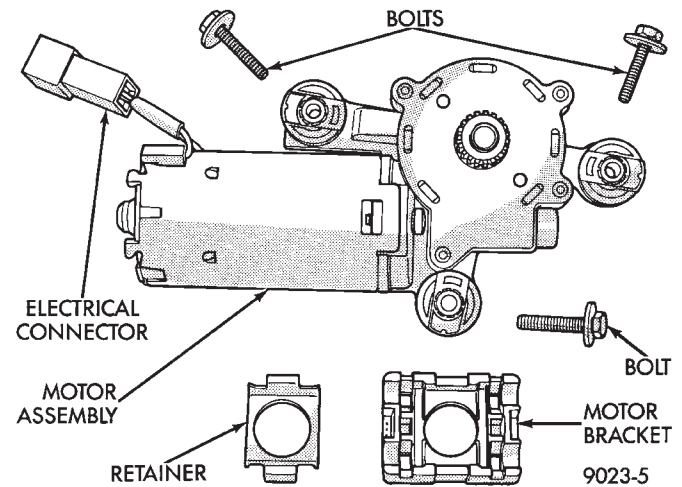
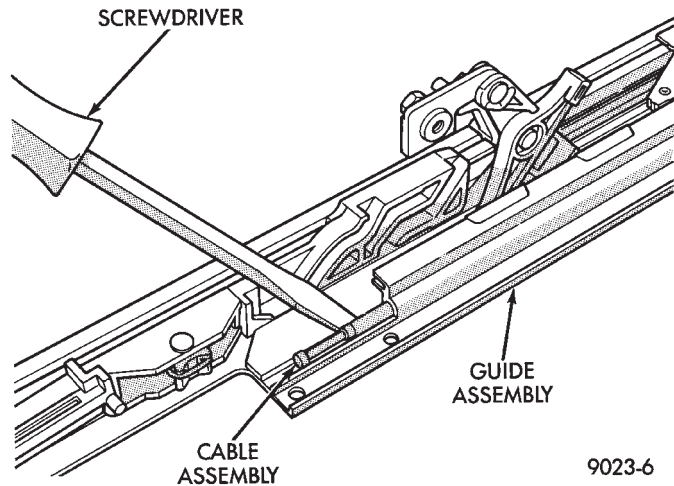


Fig. 9 Sunroof Motor And Drive Gear

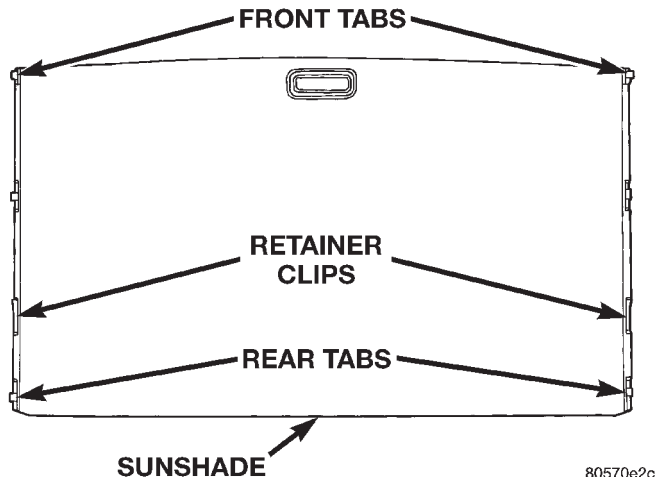
- (2) Remove headlining, wind deflector, mechanism covers, glass panel, side glass adjustment brackets, motor and drive cable locators.
- (3) Lift cable out of cable retainer and pull forward. Separate cable from assembly (Fig. 10).

INSTALLATION

Verify sunroof is in vent position. Push mechanism forward on both sides to align drive cables. Reverse the preceding operation.

REMOVAL AND INSTALLATION (Continued)**Fig. 10 Drive Cables****SUNSHADE****REMOVAL**

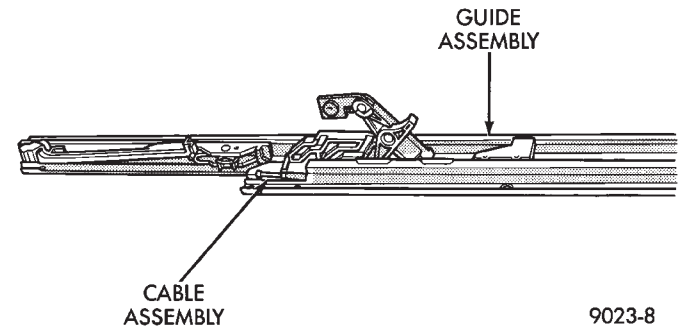
- (1) Remove wind deflector, mechanism covers and glass panel.
- (2) Position system to full rearward position.
- (3) Slide sunshade panel full forward and release the front tabs from track assembly.
- (4) Pull front and rear retaining clips inboard and lift sunshade out (Fig. 11).

**Fig. 11 Sunshade****INSTALLATION**

- (1) Reverse removal procedure.

GUIDE ASSEMBLY**REMOVAL**

- (1) Remove wind deflector, mechanism covers, glass panel, drain channel, sunshade and drive cable locator as necessary.
- (2) Move glass carriage to vent position.
- (3) Remove front slide from guide assembly.
- (4) Remove screws holding front and center guide track to unit.
- (5) Pull cable out of groove for cable end.
- (6) Pull guide outward to release from housing. Separate rear end of guide from clips. Slide guide out of unit (Fig. 12).

**Fig. 12 Guide Assembly****INSTALLATION**

- (1) Install guide cable into rear of guide assembly.
- (2) Install guide assembly at an angle so the rear portion slips under finger clips at rear of module housing.
- (3) Place cable in groove of cable holder.
- (4) Install screws in track assembly.
- (5) Install wind deflector, mechanism covers, glass panel, drain channel, sunshade and drive cable locator as necessary.

ADJUSTMENTS

GLASS PANEL VERTICAL HEIGHT ADJUSTMENT

- (1) Open glass to vent position.
- (2) Slide upper half of mechanism covers rearward until clips disengage and separate covers from vehicle (Fig. 13).
- (3) Close glass panel. Separately loosen adjusting bolts shown in View A (Fig. 13) and individually adjust the corners of the glass.
- (4) Adjust front of glass panel to 1.0 mm (0.040 in.) below top surface of roof panel.
- (5) Adjust rear of glass to 1.0 mm (0.040 in.) above top surface of roof panel.
- (6) Tighten adjustment bolts and install covers.

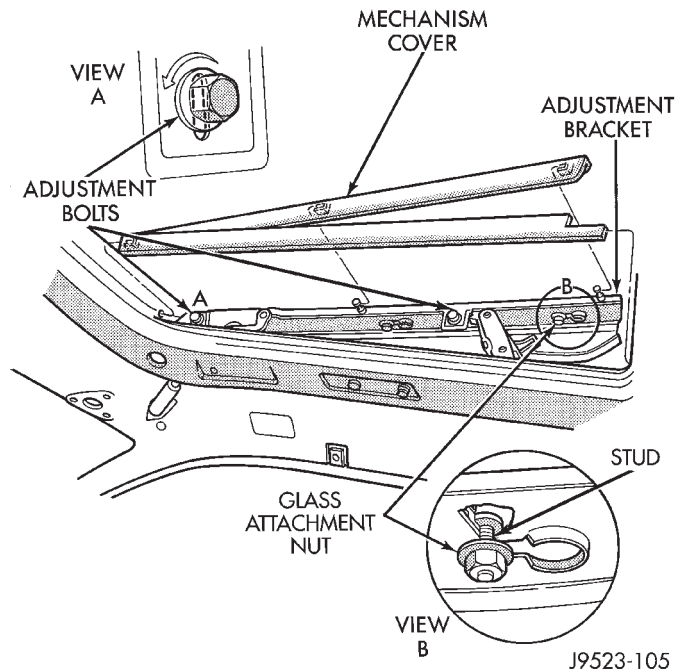


Fig. 13 Glass Adjustment

SEATS

INDEX

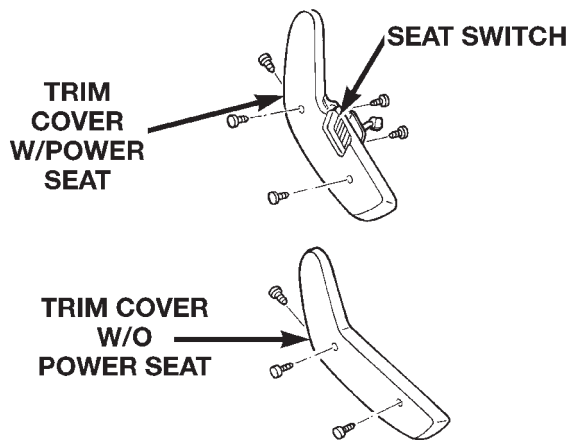
	page		page
REMOVAL AND INSTALLATION			
BUCKET SEAT BACK COVER	17	BUCKET SEAT TRACK	19
BUCKET SEAT BACK	17	LUMBAR SUPPORT	18
BUCKET SEAT CUSHION COVER	18	REAR SEAT BACK COVER	20
		REAR SEAT CUSHION COVER	20

REMOVAL AND INSTALLATION

BUCKET SEAT BACK

REMOVAL

- (1) Position seat back into full recline.
- (2) Remove seat cushion outboard trim cover (Fig. 1).
- (3) Remove bolts attaching recliner to seat cushion frame (Fig. 2).
- (4) Remove inboard pivot bolt.
- (5) Disengage electrical connectors for power lumbar, power recliner and seat heater element, if equipped.
- (6) Separate seat back from vehicle.

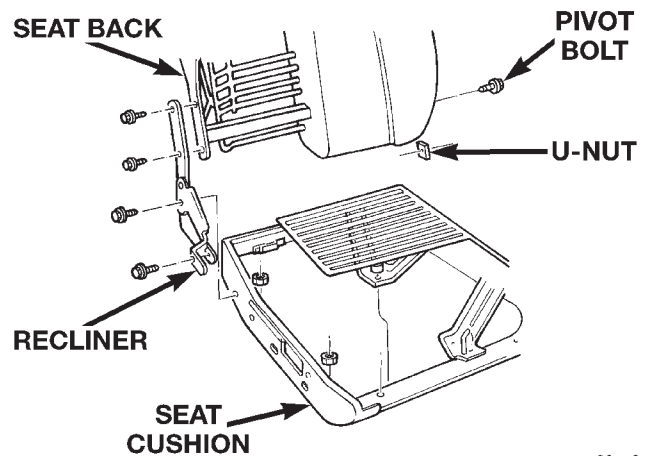


80ae0eba

Fig. 1 Bucket Seat Trim Cover

INSTALLATION

- (1) Position seat back in vehicle.
- (2) Engage electrical connectors for power lumbar, power recliner and seat heater element, if equipped.
- (3) Install inboard pivot bolt. Tighten bolt to 40 N·m (29 ft. lbs.) torque.
- (4) Install bolts attaching recliner to seat cushion frame. Tighten bolts to 28 N·m (20 ft. lbs.) torque.
- (5) Install seat cushion outboard trim cover.



80ae0ebb

Fig. 2 Bucket Seat Recliner

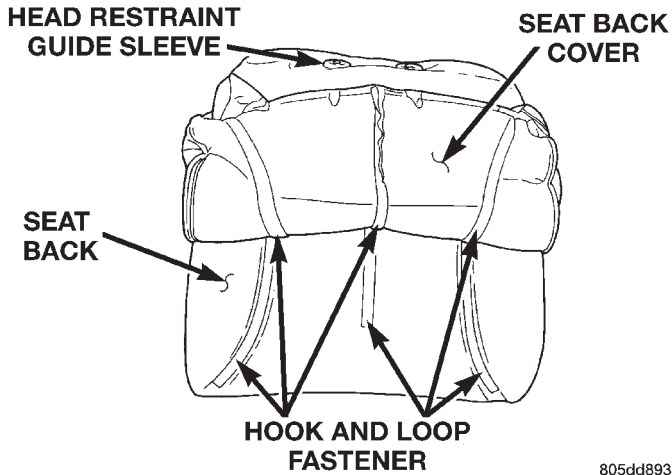
BUCKET SEAT BACK COVER

REMOVAL

- (1) Remove head restraint.
- (2) Remove seat back.
- (3) Unfasten seat back cover zipper.
- (4) Route zipper over power recliner motor, if equipped.
- (5) Slide hand between the face of the seat back cushion and the cushion cover and carefully separate hook and loop fastener (Fig. 3).
- (6) Roll cover upward to top of seat back.
- (7) Carefully slide cover over head restraint guide sleeves.
- (8) Separate cover from seat back.

INSTALLATION

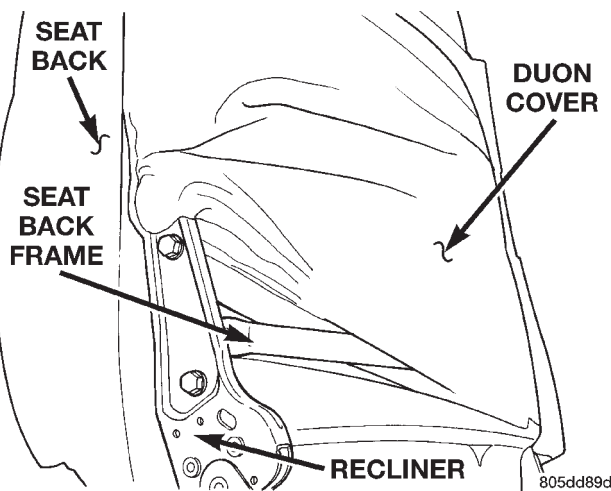
- (1) Position cover at the top of seat back.
- (2) Carefully slide cover over head restraint guide sleeves.
- (3) Roll cover downward.
- (4) Route zipper over power recliner motor, if equipped.
- (5) Fasten seat back cover zipper.
- (6) Install seat back.
- (7) Install head restraint.

REMOVAL AND INSTALLATION (Continued)

805dd893

*Fig. 3 Seat Back Cover***LUMBAR SUPPORT****REMOVAL**

- (1) Remove seat back.
- (2) Remove seat back cover.
- (3) Slide Duon® cover upward to access bolts attaching recliner to seat back frame (Fig. 4) and remove recliner.
- (4) Disengage hog rings at base of seat back.
- (5) Slide seat back frame out of seat back foam cushion.
- (6) Remove Duon cover.

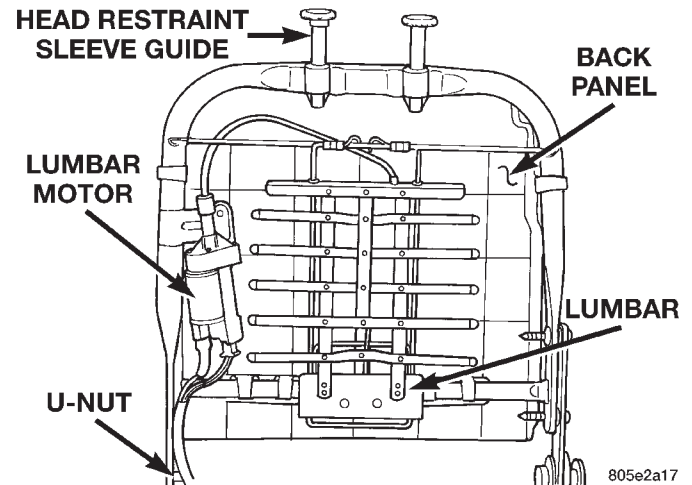


805dd89d

*Fig. 4 Seat Back***INSTALLATION**

- (1) Transfer components (Fig. 5):
 - Back panel.
 - Head restraint sleeves.
 - U-nut on inboard pivot location.
- (2) Install recliner. Tighten to 28 N·m (20 ft. lbs.) torque.
- (3) Slide on Duon cover.
- (4) Slide on seat back foam cushion

- (5) Install hog rings at seat back base.
- (6) Install seat back cover.
- (7) Route lumbar and heater harness, if equipped.



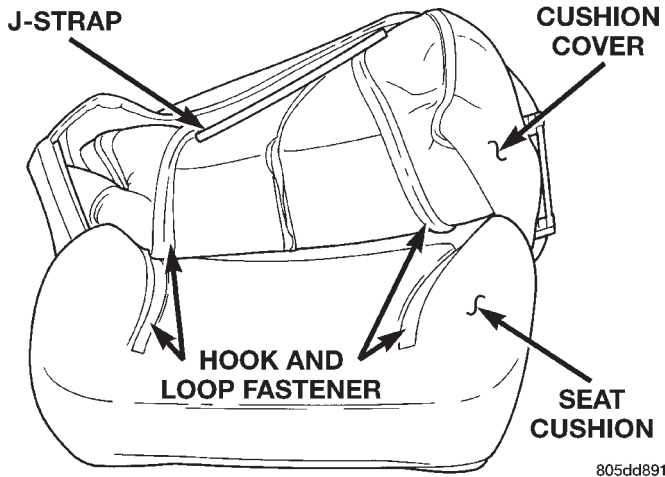
805e2a17

*Fig. 5 Lumbar Support***BUCKET SEAT CUSHION COVER****REMOVAL**

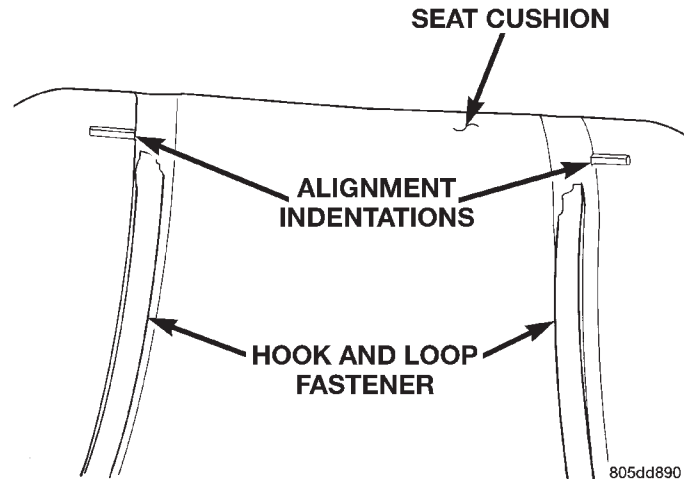
- (1) Remove seat from vehicle.
- (2) Remove seat back.
- (3) Using a trim stick, carefully pry knobs from seat function switches, if equipped.
- (4) Remove screws attaching seat function switch to seat trim panel.
- (5) Disengage J-strap attaching seat cover to front of seat cushion frame.
- (6) Using a trim stick or small flat blade, disengage clips attaching seat cover to each side of seat cushion frame.
- (7) Disengage hog rings attaching seat cover to rear of seat cushion frame.
- (8) Route seat function switches through access hole on outboard side of seat cushion, if equipped.
- (9) Disengage seat cushion heater element connector, if equipped.
- (10) Slide hand between seat cushion cover and seat cushion. Carefully separate hook and loop fastener (Fig. 6).
- (11) Separate seat cushion cover from seat cushion.

INSTALLATION

- (1) Position seat cover on cushion.
- (2) Align seat cover with cushion alignment indentations (Fig. 7).
- (3) Engage seat cushion heater element connector, if equipped.
- (4) Route seat function switches through access hole on outboard side of seat cushion, if equipped.
- (5) Engage J-strap attaching seat cover to front of seat cushion frame.

REMOVAL AND INSTALLATION (Continued)

805dd891

Fig. 6 Seat Cushion Cover

805dd890

Fig. 7 Seat Cushion Alignment Indentations

(6) Engage hog rings attaching seat cover to rear of seat cushion frame.

(7) Engage clips attaching seat cover to each side of seat cushion frame.

(8) Install screws attaching seat function switch to seat trim panel.

(9) Install seat back.

(10) Position knobs onto seat function switches and press into place.

(11) Install seat.

BUCKET SEAT TRACK**REMOVAL**

(1) Remove seat.

(2) Remove nuts attaching seat track to seat cushion frame (Fig. 8).

(3) Disengage seat memory module connector, if equipped.

(4) Separate seat track from seat cushion frame.

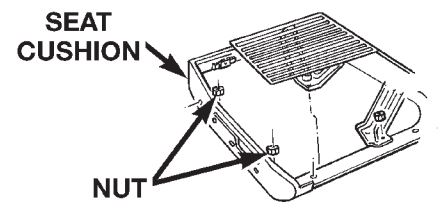
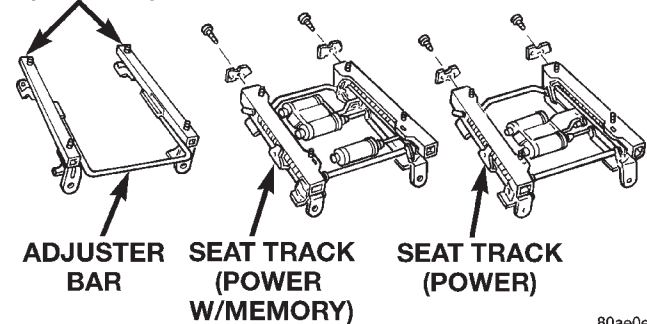
INSTALLATION

(1) Transfer seat memory module, if equipped.

(2) Position seat track on seat cushion frame.

(3) Engage seat memory module connector, if equipped.

(4) Install nuts attaching seat track to seat cushion frame. Tighten nuts to 20 N·m (15 ft. lbs.) torque.

**SEAT TRACK (MANUAL)**

80ae0eb8

Fig. 8 Seat Track

REMOVAL AND INSTALLATION (Continued)**REAR SEAT BACK COVER****REMOVAL**

(1) Remove seatback from vehicle. If necessary, refer to removal procedure.

(2) Remove headrest. Twist knob under headrest and pull up and out of cylinders in seatback.

(3) Unfasten zipper (Fig. 9) on trim cover, and peel cover off pad by turning inside-out.

(4) If necessary, headrest cylinders may be removed from seatback frame. Squeeze locking tabs on cylinder and slide cylinder upward and remove from frame bracket.

INSTALLATION

Reverse removal procedure.

REAR SEAT CUSHION COVER**REMOVAL**

(1) Remove seat cushion from vehicle. If necessary, refer to removal procedure.

(2) Using a trim tool, disengage seat cover retainers that hold trim cover to flange of cushion pan.

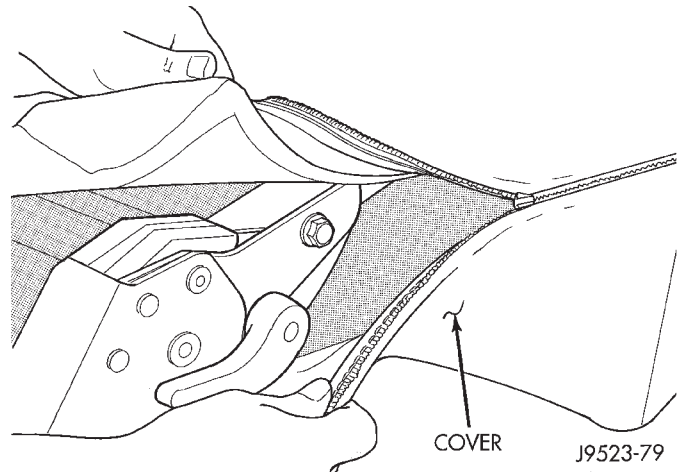


Fig. 9 Seatback Cover Removal

(3) Remove pad and cover from pan.

(4) Separate cover from pad by turning inside-out and opening hogrings along 3 grooves in pad.

INSTALLATION

Reverse removal procedure.

BODY COMPONENTS

INDEX

	page		page
DIAGNOSIS AND TESTING			
UNIVERSAL TRANSMITTER	23	LIFTGATE FLIP-UP GLASS LATCH HANDLE/ STRIKER	50
WATER LEAKS	22	LIFTGATE FLIP-UP GLASS LATCH	50
WIND NOISE	23	LIFTGATE FLIP-UP GLASS WEATHERSTRIP	50
SERVICE PROCEDURES			
BODY LUBRICATION	23	LIFTGATE FLIP-UP GLASS	49
REMOVAL AND INSTALLATION			
A-PILLAR TRIM	39	LIFTGATE HINGE	48
ASSIST HANDLE	39	LIFTGATE LATCH STRIKER	49
BODY SIDE CLADDING	38	LIFTGATE LATCH	48
BODY STRIPES/DECALS	27	LIFTGATE LOCK CYLINDER	48
C-PILLAR TRIM	41	LIFTGATE OPENING WEATHERSTRIP	49
CARGO CARPET/MAT	44	LIFTGATE OUTSIDE HANDLE	48
COWL GRILLE AND SCREEN	26	LIFTGATE TRIM PANEL	46
D-PILLAR TRIM	41	LIFTGATE	47
EXTERIOR NAMEPLATES	27	LOWER B-PILLAR TRIM PANEL	39
FLIP-UP GLASS SWITCH	50	LUGGAGE RACK	51
FLOOR CONSOLE	43	LUGGAGE RACK—LIMITED PLUS	52
FRONT BUCKET SEAT	42	QUARTER TRIM PANELS	41
FRONT CARPET/MAT	44	QUARTER WINDOW APPLIQUE/AIR EXHAUSTER	51
FRONT DOOR HINGE	31	REAR DOOR HINGE	35
FRONT DOOR INNER BELT SEAL	32	REAR DOOR INNER BELT SEAL	36
FRONT DOOR INSIDE HANDLE ACTUATOR	32	REAR DOOR INSIDE HANDLE ACTUATOR	36
FRONT DOOR LATCH STRIKER	32	REAR DOOR LATCH STRIKER	36
FRONT DOOR LATCH	32	REAR DOOR LATCH	35
FRONT DOOR LOCK CYLINDER	31	REAR DOOR OPENING WEATHERSTRIP	37
FRONT DOOR OPENING WEATHERSTRIP	33	REAR DOOR OUTER BELT SEAL	37
FRONT DOOR OUTER BELT SEAL	32	REAR DOOR OUTSIDE HANDLE	35
FRONT DOOR OUTSIDE HANDLE	31	REAR DOOR SCUFF PLATE	41
FRONT DOOR RUN CHANNEL WEATHERSTRIP	33	REAR DOOR TRIM PANEL	34
FRONT DOOR SCUFF PLATE	39	REAR DOOR WINDOW GLASS	38
FRONT DOOR TRIM PANEL	29	REAR DOOR WINDOW REGULATOR	37
FRONT DOOR WATERDAM	30	REAR DOOR	35
FRONT DOOR WINDOW GLASS	34	REAR SEAT CUSHION	43
FRONT DOOR WINDOW REGULATOR	33	REAR SEATBACK	43
FRONT DOOR	30	REAR SHOULDER/LAP BELT/BUCKLE	42
FRONT FENDER	29	REARVIEW MIRROR SUPPORT BRACKET	45
FRONT SHOULDER BELT/BUCKLE	42	REARVIEW MIRROR	45
FUEL DOOR	38	SAFETY LATCH STRIKER	26
GRILLE OPENING REINFORCEMENT (GOR)	24	SIDE VIEW MIRRORS	28
GRILLE	24	SUNVISOR	45
HEADLINER	46	UPPER B-PILLAR TRIM PANEL	39
HOOD HINGE	25	ADJUSTMENTS	
HOOD INSULATION PANEL	25	DOOR LATCH ADJUSTMENT	53
HOOD LATCH STRIKER	26	DOOR	53
HOOD LATCH	25	HOOD ADJUSTMENT	52
HOOD LOUVER	25	LIFTGATE	53
HOOD RELEASE CABLE	26	SPECIFICATIONS	
HOOD	24	BODY LUBRICANTS	54
LICENSE PLATE LAMP HOUSING	51	SPECIAL TOOLS	
		BODY	54

DIAGNOSIS AND TESTING

WATER LEAKS

Water leaks can be caused by poor sealing, improper body component alignment, body seam porosity, missing plugs, or blocked drain holes. Centrifugal and gravitational force can cause water to drip from a location away from the actual leak point, making leak detection difficult. All body sealing points should be water tight in normal wet-driving conditions. Water flowing downward from the front of the vehicle should not enter the passenger or luggage compartment. Moving sealing surfaces will not always seal water tight under all conditions. At times, side glass or door seals will allow water to enter the passenger compartment during high pressure washing or hard driving rain (severe) conditions. Overcompensating on door or glass adjustments to stop a water leak that occurs under severe conditions can cause premature seal wear and excessive closing or latching effort. After completing a repair, water-test vehicle to verify leak has stopped before returning vehicle to use.

VISUAL INSPECTION BEFORE WATER LEAK TESTS

Verify that floor and body plugs are in place, body drains are clear, and body components are properly aligned and sealed. If component alignment or sealing is necessary, refer to the appropriate section of this group for proper procedures.

WATER LEAK TESTS

WARNING: DO NOT USE ELECTRIC SHOP LIGHTS OR TOOLS IN WATER TEST AREA. PERSONAL INJURY CAN RESULT.

When the conditions causing a water leak have been determined, simulate the conditions as closely as possible.

- If a leak occurs with the vehicle parked in a steady light rain, flood the leak area with an open-ended garden hose.
- If a leak occurs while driving at highway speeds in a steady rain, test the leak area with a reasonable velocity stream or fan spray of water. Direct the spray in a direction comparable to actual conditions.
- If a leak occurs when the vehicle is parked on an incline, hoist the end or side of the vehicle to simulate this condition. This method can be used when the leak occurs when the vehicle accelerates, stops or turns. If the leak occurs on acceleration, hoist the front of the vehicle. If the leak occurs when braking, hoist the back of the vehicle. If the leak occurs on left turns, hoist the left side of the vehicle. If the leak occurs on right turns, hoist the right side of the vehi-

cle. For hoisting recommendations refer to Group 0, Lubrication and Maintenance, General Information section.

WATER LEAK DETECTION

To detect a water leak point-of-entry, do a water test and watch for water tracks or droplets forming on the inside of the vehicle. If necessary, remove interior trim covers or panels to gain visual access to the leak area. If the hose cannot be positioned without being held, have someone help do the water test.

Some water leaks must be tested for a considerable length of time to become apparent. When a leak appears, find the highest point of the water track or drop. The highest point usually will show the point of entry. After leak point has been found, repair the leak and water test to verify that the leak has stopped.

Locating the entry point of water that is leaking into a cavity between panels can be difficult. The trapped water may splash or run from the cavity, often at a distance from the entry point. Most water leaks of this type become apparent after accelerating, stopping, turning, or when on an incline.

MIRROR INSPECTION METHOD

When a leak point area is visually obstructed, use a suitable mirror to gain visual access. A mirror can also be used to deflect light to a limited-access area to assist in locating a leak point.

BRIGHT LIGHT LEAK TEST METHOD

Some water leaks in the luggage compartment can be detected without water testing. Position the vehicle in a brightly lit area. From inside the darkened luggage compartment inspect around seals and body seams. If necessary, have a helper direct a drop light over the suspected leak areas around the luggage compartment. If light is visible through a normally sealed location, water could enter through the opening.

PRESSURIZED LEAK TEST METHOD

When a water leak into the passenger compartment cannot be detected by water testing, pressurize the passenger compartment and soap test exterior of the vehicle. To pressurize the passenger compartment, close all doors and windows, start engine, and set heater control to high blower in HEAT position. If engine can not be started, connect a charger to the battery to ensure adequate voltage to the blower. With interior pressurized, apply dish detergent solution to suspected leak area on the exterior of the vehicle. Apply detergent solution with spray device or soft bristle brush. If soap bubbles occur at a body seam, joint, seal or gasket, the leak entry point could be at that location.

DIAGNOSIS AND TESTING (Continued)**WIND NOISE**

Wind noise is the result of most air leaks. Air leaks can be caused by poor sealing, improper body component alignment, body seam porosity, or missing plugs in the engine compartment or door hinge pillar areas. All body sealing points should be airtight in normal driving conditions. Moving sealing surfaces will not always seal airtight under all conditions. At times, side glass or door seals will allow wind noise to be noticed in the passenger compartment during high crosswinds. Over compensating on door or glass adjustments to stop wind noise that occurs under severe conditions can cause premature seal wear and excessive closing or latching effort. After a repair procedure has been performed, test vehicle to verify noise has stopped before returning vehicle to use.

Wind noise can also be caused by improperly fitted exterior moldings or body ornamentation. Loose moldings can flutter, creating a buzzing or chattering noise. An open cavity or protruding edge can create a whistling or howling noise. Inspect the exterior of the vehicle to verify that these conditions do not exist.

VISUAL INSPECTION BEFORE TESTS

Verify that floor and body plugs are in place and body components are aligned and sealed. If component alignment or sealing is necessary, refer to the appropriate section of this group for proper procedures.

ROAD TESTING WIND NOISE

(1) Drive the vehicle to verify the general location of the wind noise.

(2) Apply 50 mm (2 in.) masking tape in 150 mm (6 in.) lengths along weatherstrips, weld seams or moldings. After each length is applied, drive the vehicle. If noise goes away after a piece of tape is applied, remove tape, locate, and repair defect.

POSSIBLE CAUSE OF WIND NOISE

- Moldings standing away from body surface can catch wind and whistle.
- Gaps in sealed areas behind overhanging body flanges can cause wind-rushing sounds.
- Misaligned movable components.
- Missing or improperly installed plugs in pillars.
- Weld burn through holes.

UNIVERSAL TRANSMITTER

Universal Transmitter will operate most:

- Garage door opener
- Gate opener
- Home/Office lighting and/or security system(s)

The transmitter is powered by the M1 circuit that supplies voltage to the driver side visor/vanity lamp.

TRAINING THE UNIVERSAL TRANSMITTER

To train the transmitter refer to the Owner's Manual.

TESTING TRANSMITTER

(1) Check for battery voltage at the Universal Transmitter by pressing a button and seeing if a red lamp comes on. If OK, go to Step 6. If not OK, go to Step 2.

(2) Check if visor/vanity lamp lights. If lamp lights, replace visor. If lamp does not light go to Step 3.

(3) Check fuse. If OK, go to Step 4. If not OK, repair as necessary.

(4) Remove visor and test M1 wire for battery voltage at the visor connector. If voltage is OK, go to Step 5. If no voltage repair wire as necessary. Refer to Group 8W, Wiring Diagrams for proper terminals.

(5) Test Z1 wire for ground at the visor connector. If ground is OK, replace visor. If no ground repair wire as necessary.

(6) Check the instructions in the Owner's Manual and retrain the transmitter. If the transmitter can not be trained replace visor.

SERVICE PROCEDURES**BODY LUBRICATION**

All mechanisms and linkages should be lubricated when necessary. This will maintain ease of operation and provide protection against rust and excessive wear. The weatherstrip seals should be lubricated to prolong their life as well as to improve door sealing.

All applicable exterior and interior vehicle operating mechanisms should be inspected and cleaned. Pivot/sliding contact areas on the mechanisms should then be lubricated.

(1) When necessary, lubricate the operating mechanisms with the specified lubricants.

(2) Apply silicone lubricant to a cloth and wipe it on door seals to avoid over-spray that can soil passenger's clothing.

(3) Before applying lubricant, the component should be wiped clean. After lubrication, any excess lubricant should be removed.

(4) The hood latch, latch release mechanism, latch striker, and safety latch should be lubricated periodically.

(5) The door lock cylinders should be lubricated twice each year (preferably autumn and spring):

- Spray a small amount of lock cylinder lubricant directly into the lock cylinder.
- Apply a small amount to the key and insert it into the lock cylinder.
- Rotate it to the locked position and then back to the unlocked position several times.

SERVICE PROCEDURES (Continued)

- Remove the key. Wipe the lubricant from it with a clean cloth to avoid soiling of clothing.

REMOVAL AND INSTALLATION

GRILLE

REMOVAL

- (1) Open hood.
- (2) Remove screws attaching grille to grille opening reinforcement (Fig. 1).
- (3) Separate grille from vehicle.

INSTALLATION

- (1) Position grille at grille opening panel.
- (2) Install screws.

GRILLE OPENING REINFORCEMENT (GOR)

REMOVAL

- (1) Open hood.
- (2) Remove grille.
- (3) Remove front fascia. Refer to Group 13, Frame and Bumpers for Removal/Installation procedures.
- (4) If equipped, remove license plate bracket from bumper fascia/crossmember.
- (5) Remove side marker and turn signal lamps. Refer to Group 8L, for Removal/Installation procedures.
- (6) Remove headlamps.

- (7) Remove bolts that attach grille opening reinforcement (GOR) to the upper and lower crossmember (Fig. 1).

- (8) Remove grille opening reinforcement.

- (9) If necessary, remove air seals located at headlamp wiring inlets.

INSTALLATION

- (1) If necessary, install air seals located at headlamp wiring inlets.

- (2) Position grille opening reinforcement on vehicle.

- (3) Install bolts that attach grille opening reinforcement (GOR) to the upper and lower crossmember (Fig. 1).

- (4) Install headlamps.

- (5) Install side marker and turn signal lamps. Refer to Group 8L, for Removal/Installation procedures.

- (6) If removed, install license plate bracket to bumper fascia/crossmember.

- (7) Install front fascia. Refer to Group 13, Frame and Bumpers for Removal/Installation procedures.

- (8) Install grille.

HOOD

REMOVAL

- (1) Raise hood.

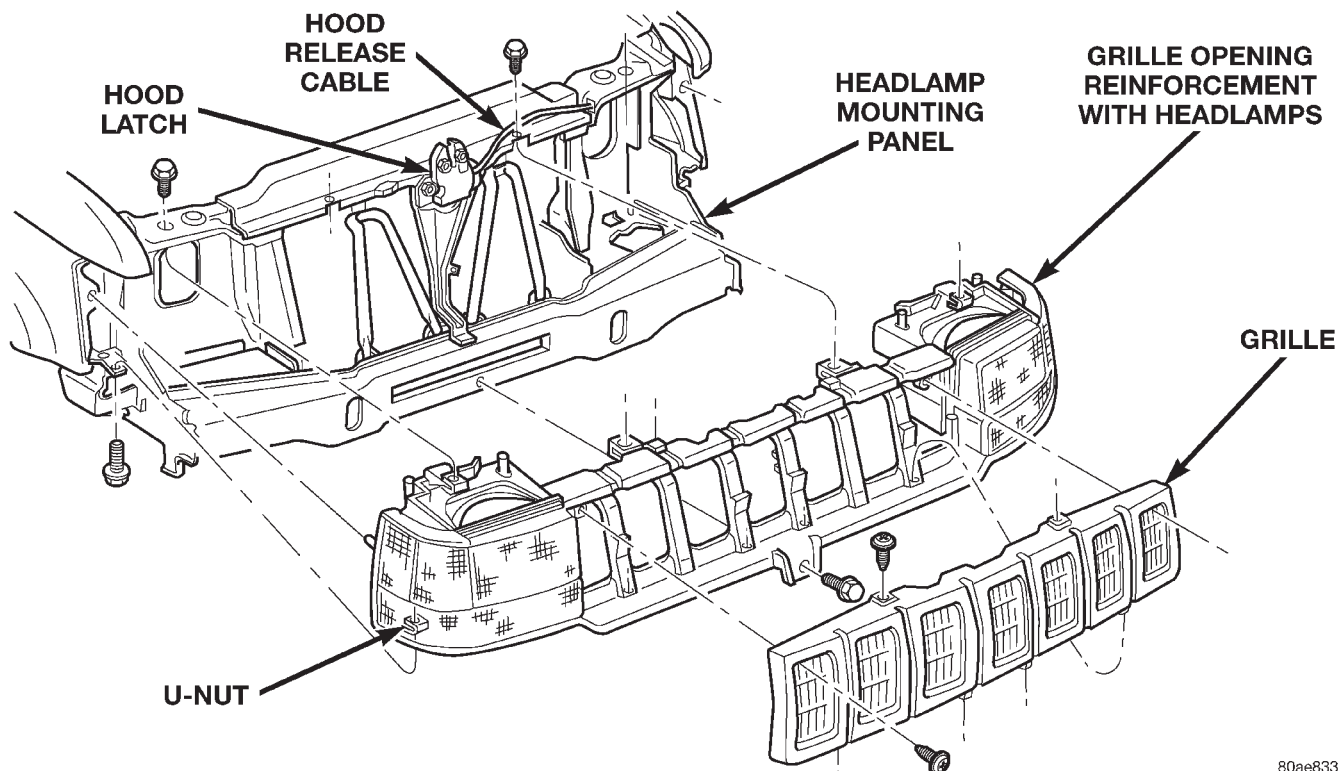


Fig. 1 Grille and Grille Opening Reinforcement (GOR)

REMOVAL AND INSTALLATION (Continued)

(2) If equipped, disconnect underhood lamp connector.

(3) Mark location of the hood hinges and hinge shims (Fig. 2) for installation alignment.

(4) Remove nuts that attach hinges to hood. Remove hood from vehicle with aid of a helper.

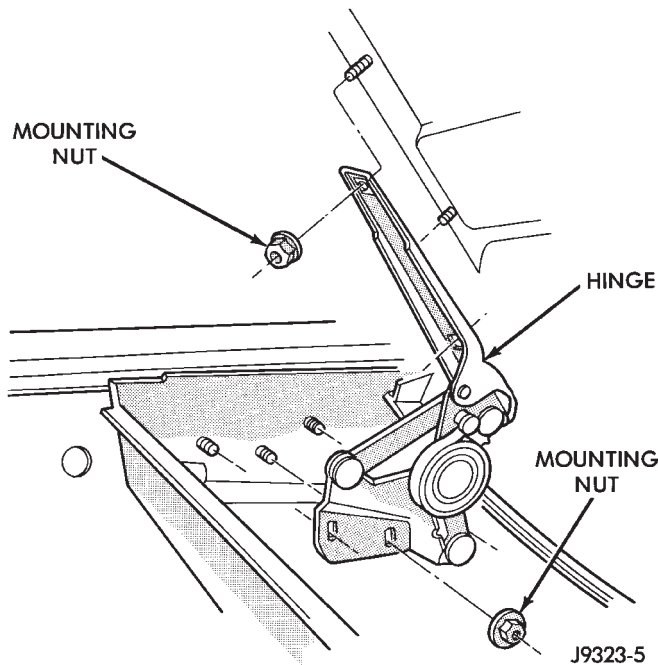


Fig. 2 Hood Hinge

INSTALLATION

(1) Position hood on shims and hinges. Fingertighten hinge nuts.

(2) Align hinges and shims with installation reference marks. Tighten hinge nuts to 23 N·m (17 ft-lbs) torque.

(3) Test latch release cable and latches for proper operation.

(4) Connect underhood lamp connector.

(5) Inspect hood for proper alignment and adjust as necessary.

HOOD INSULATION PANEL

REMOVAL

(1) Raise hood.

(2) Remove the insulation panel fasteners (Fig. 3).

(3) Remove the insulation panel from the hood.

INSTALLATION

(1) Position the insulation panel on the hood.

(2) Install the insulation panel fasteners.

(3) Close hood.

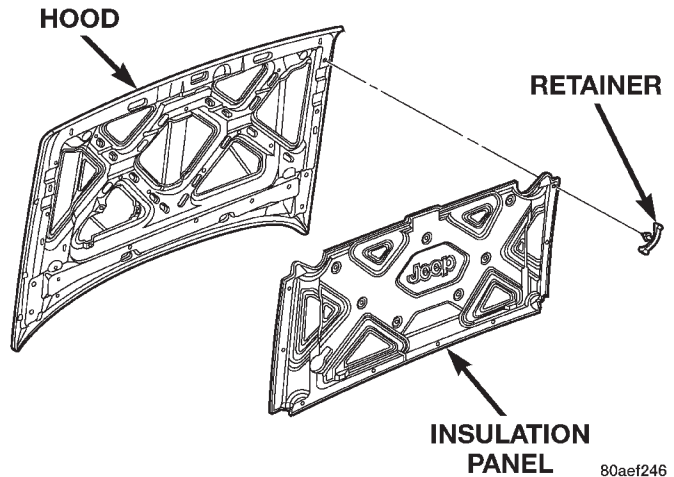


Fig. 3 Hood Insulation Panel

HOOD LOUVER

REMOVAL

(1) Raise hood.

(2) Remove the nuts attaching the louver to the hood.

(3) Separate the louver from the hood.

INSTALLATION

(1) Position the louver on the hood.

(2) Install the nuts attaching the louver to the hood.

(3) Close hood.

HOOD HINGE

(1) Remove hood from vehicle.

(2) Remove hinge retaining nuts from studs (Fig. 2).

(3) Remove hinge from inner cowl side panel.

INSTALLATION

(1) Position hinge over studs.

(2) Install hinge retaining nuts on studs. Tighten retaining nuts to 23 N·m (17 ft. lbs.) torque.

(3) Install hood.

(4) Adjust hood as necessary. If necessary, refer to adjustment procedure.

HOOD LATCH

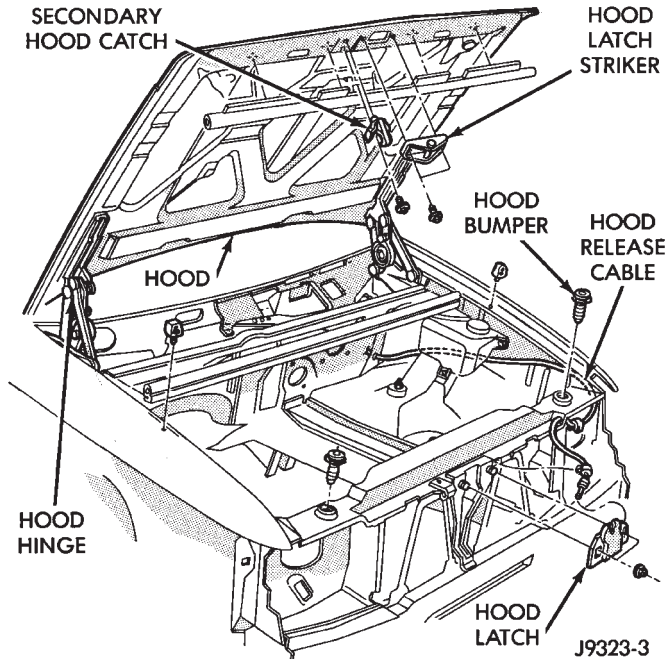
REMOVAL

(1) Remove nuts that attach latch to radiator crossmember support (Fig. 4).

(2) Disconnect latch from the hood release cable. Remove latch.

INSTALLATION

(1) Connect latch to latch release cable. Position it on radiator crossmember support.

REMOVAL AND INSTALLATION (Continued)**Fig. 4 Hood Striker and Release Cable**

(2) Install nuts. Tighten nuts to 11 N·m (8 ft-lbs) torque.

(3) Test operation of latch release cable and latch.

HOOD LATCH STRIKER**REMOVAL**

- (1) Remove bolts attaching striker to hood.
- (2) Remove striker from hood.

INSTALLATION

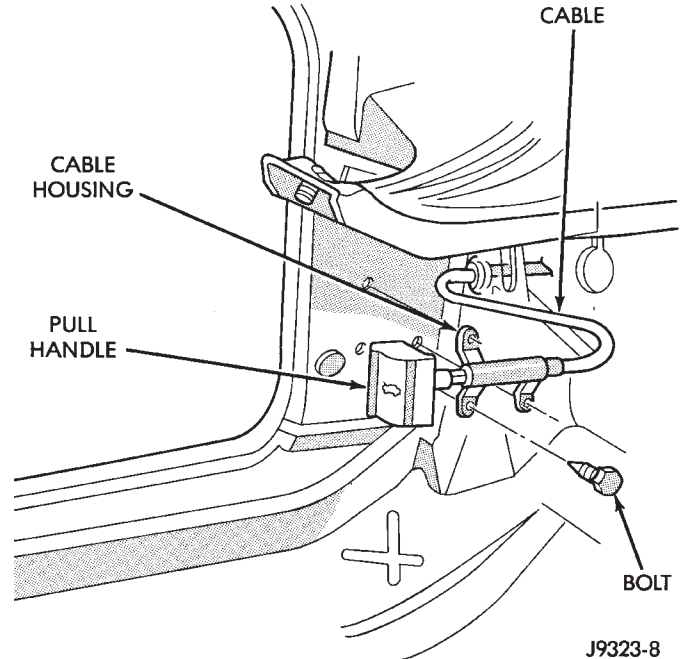
- (1) Position striker on hood.
- (2) Install bolts. Tighten bolts to 11 N·m (8 ft-lbs) torque.
- (3) Test striker/hood alignment by opening and closing hood several times. Adjust striker, if necessary.

HOOD RELEASE CABLE**REMOVAL**

- (1) Disconnect cable from hood latch.
- (2) Disconnect cable from retaining clips.
- (3) Remove left cowl side (kick) trim panel.
- (4) Remove cable bracket attaching screws from cowl side panel (Fig. 5).
- (5) Pull cable through dash panel and remove it from under instrument panel.

INSTALLATION

- (1) Insert replacement cable end through hole in dash panel into engine compartment.
- (2) Pull cable forward and seat grommet in dash panel.

**Fig. 5 Hood Release Cable**

(3) Position cable bracket on cowl side panel and install screws. Tighten screws to 11 N·m (8 ft-lbs) torque.

- (4) Install left cowl side trim panel.
- (5) Route cable into retaining clips.
- (6) Attach cable to hood latch.
- (7) Test release cable for proper operation.

SAFETY LATCH STRIKER**REMOVAL**

- (1) Remove latch striker screw from hood.
- (2) Remove striker from hood.

INSTALLATION

- (1) Position striker on hood. Install screw.
- (2) Test safety latch operation.

COWL GRILLE AND SCREEN**REMOVAL**

- (1) Remove wiper arms. Refer to Group 8K, Wiper and Washer Systems for Removal/Installation procedures.
- (2) Remove screws that attach grille to cowl (Fig. 6).
- (3) Remove windshield washer tubes at connector.
- (4) Remove cowl grille and screen from cowl.

INSTALLATION

- (1) Position cowl grille on cowl. Install windshield washer tubes at connector.
- (2) Install cowl grille retaining screws.
- (3) Install windshield wiper arms.

REMOVAL AND INSTALLATION (Continued)

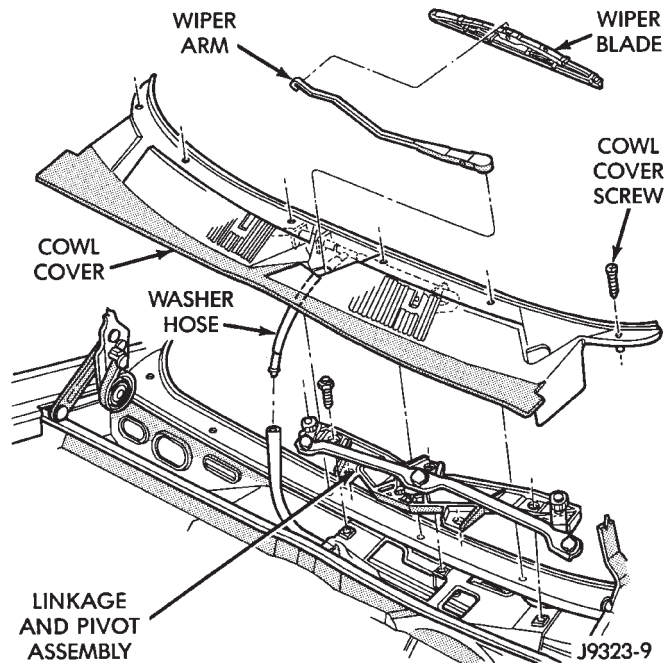


Fig. 6 Cowl Grille Components

EXTERIOR NAMEPLATES

All of the vehicle exterior nameplates (Fig. 7), are attached to the vehicle panels with adhesive.

REMOVAL

(1) Using a trim stick or suitable tool, carefully pry nameplate from body panel.

INSTALLATION

(1) Clean panel surface.
 (2) Position replacement nameplate on panel and push inward to seat it.

BODY STRIPES/DECALS

Body stripes are durable, weather-resistant tape stripes with pressure-sensitive backing. The tape stripe is protected by a carrier until installed on a body panel. Carrier also is an installation alignment aid.

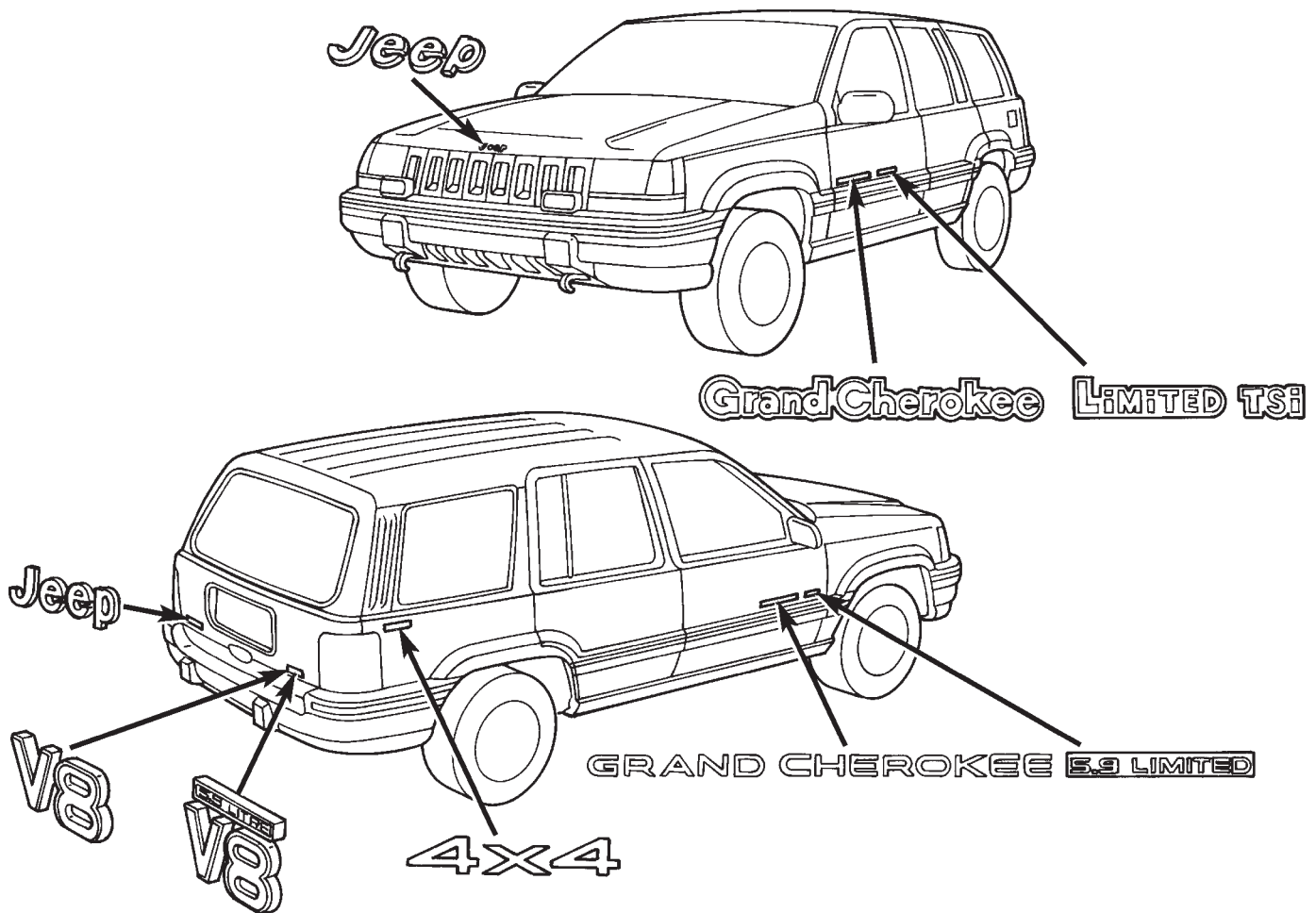


Fig. 7 Exterior Nameplates

REMOVAL AND INSTALLATION (Continued)

REMOVAL

- (1) Remove exterior trim as necessary to clear captured edges of tape stripe being removed.
- (2) Remove tape stripe using a suitable heat gun or lamp. This will soften adhesive backing.
- (3) Clean adhesive residue from body finish using a suitable adhesive remover.

INSTALLATION

The painted surface of the body panel to be covered by a tape stripe must be smooth and completely cured before stripe can be applied. If painted surface is not smooth, wet sand with 600 grit wet/dry sand paper until surface is smooth.

Ripples and feather edges will read through stripe if surface is not properly prepared.

Installation Equipment:

- Bucket filled with a mild dish soap solution.
- Lint free applicator cloth or sponge.
- Body putty applicator squeegee.
- Heat gun or sun lamp.
- Razor knife.

(1) With backing still in place, position stripe across panel to receive the stripe. Apply masking at top of stripe to hold it in position.

(2) Mark outside edge of panel on stripe with grease pencil.

(3) Trim stripe to within 17 mm (0.750 in.) of out-line marks.

(4) Spread stripe across a smooth flat work surface, stripe side down.

(5) Peel paper backing away from stripe exposing adhesive backing of stripe (Fig. 8).

(6) Apply soap solution liberally to adhesive backing of stripe.

(7) Apply soap solution to body panel surface.

(8) Place stripe into position on body panel. Smooth out wrinkles by pulling lightly on edges of tape stripe until it lays flat on panel surface.

(9) Push air pockets from under tape stripe to perimeter of panel from center of the tape stripe out.

(10) Remove air bubbles from under tape stripe using a body putty squeegee.

CAUTION: Do not cut into painted surface of body when trimming tape stripe to size.

(11) Trim tape stripe to size using a razor knife. Leave at least 13 mm (0.5 in.) for edges of doors and openings.

CAUTION: Do not overheat tape stripe when performing step 12.

(12) Apply heat to tape stripe to evaporate residual moisture from edges of tape stripe. This will also

allow tape stripe to be stretched into concave surfaces.

(13) Edge turn tape stripe around doors or fenders.

(14) Install exterior trim if necessary. Small air or water bubbles under tape stripe can be pierced with a pin and smoothed out.

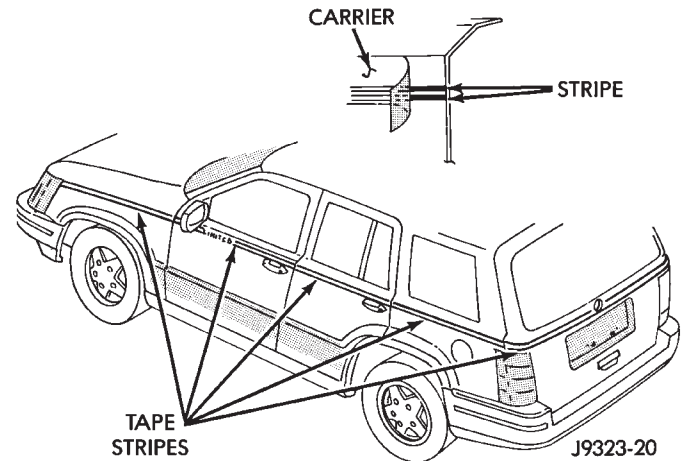


Fig. 8 Tape Stripe

SIDE VIEW MIRRORS

REMOVAL

- (1) Remove door trim panel.
- (2) Disengage power mirror connector from trim panel.
- (3) If equipped, disengage two-way electrochromic mirror connector from wiring harness.
- (4) Remove clips attaching mirror harness to door inner panel.
- (5) Remove mirror flag seal.
- (6) Remove mirror retaining nuts (Fig. 9).
- (7) Remove mirror from door. Refer to Group 8, Electrical for additional information involving power mirrors.

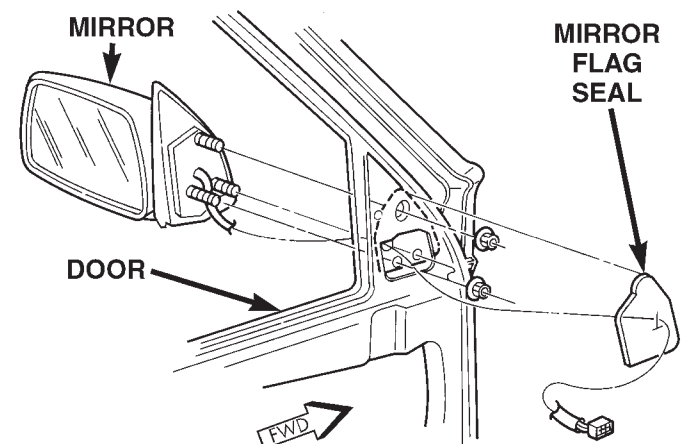


Fig. 9 Side View Mirror

REMOVAL AND INSTALLATION (Continued)

INSTALLATION

- (1) Position mirror on door. Verify that the gasket seal is properly positioned.
- (2) Install mirror retaining nuts.
- (3) Install mirror flag seal.
- (4) Install clips attaching mirror harness to door inner panel.
- (5) If equipped, engage two-way electrochromic mirror connector to wiring harness.
- (6) Engage power mirror connector at trim panel.
- (7) Install door trim panel.

FRONT FENDER

REMOVAL

- (1) Remove headlamp, side marker and turn signal lamp. Refer to Group 8L, Lamps for service information.
- (2) Remove front bumper fascia. Refer to Group 13, Frame and Bumpers for service information.
- (3) Remove front wheel.
- (4) Remove fasteners attaching inner front fender liner to fender and inner fender (Fig. 10).
- (5) Remove inner fender liner.
- (6) Right fender only:
 - (a) If equipped, remove radio antenna mast, nut, pad and base from fender. Refer to group 8F, Audio Systems for Removal/Installation procedures.
- (7) From inside wheel well, remove bolts at rear of fender reinforcements (Fig. 11).
- (8) Remove bolts at front fender bracket (Fig. 12).
- (9) Remove bolts at lower rear of fender at A-pillar.
- (10) Remove upper mounting bolts at top of fender.
- (11) Remove fender from inner fender.

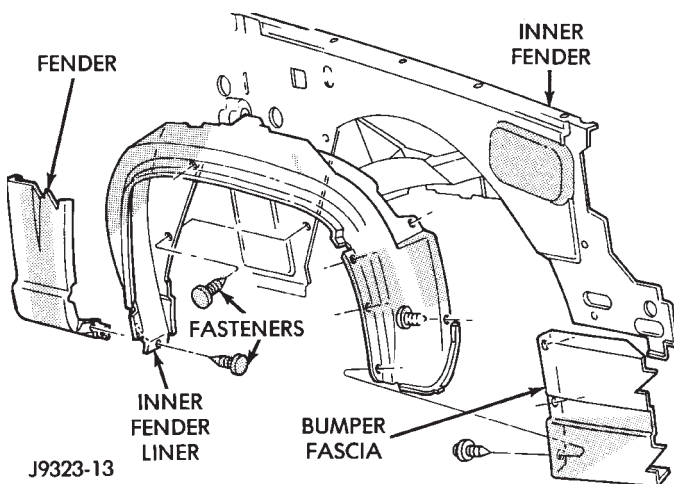


Fig. 10 Inner Fender Liner

INSTALLATION

- (1) Position fender on inner fender panel.
- (2) Install all of fender attaching screws finger-tight.

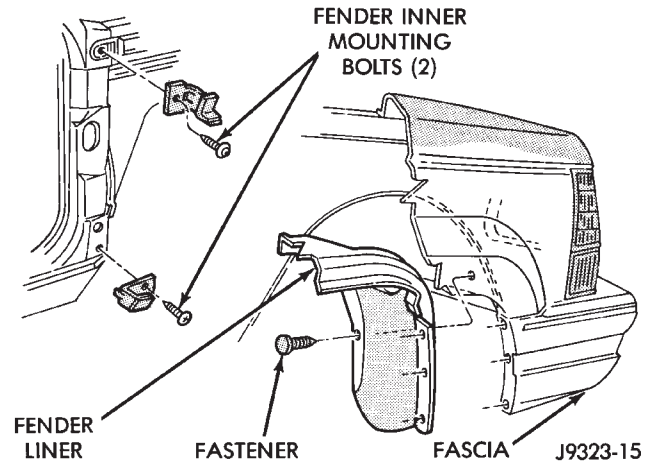


Fig. 11 Inner Fender Mounting

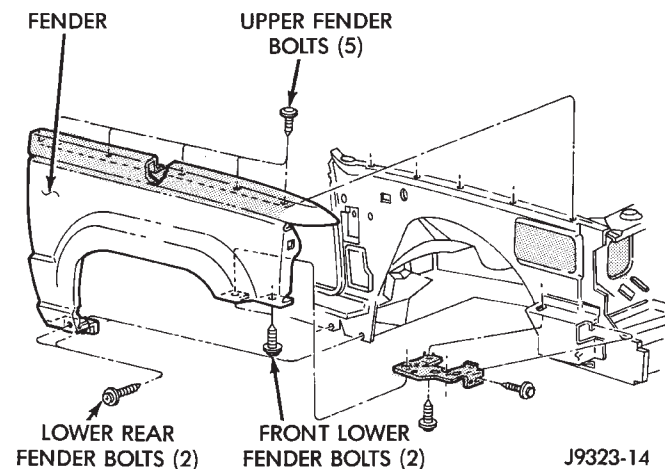


Fig. 12 Fender Mounting

- (3) Align fender with adjacent body panels. Tighten fender bolts to 9 N-m (80 in-lbs) torque.
- (4) Install inner fender liner.
- (5) Install front wheel.
- (6) Install front bumper fascia. If necessary refer to Group 13, Frame and Bumpers for installation instructions.
- (7) Install front headlamp, side marker and turn signal lamp. If necessary refer to Group 8L, Lamps for service information.

FRONT DOOR TRIM PANEL

REMOVAL

- (1) Remove screw attaching trim panel to inside release handle (Fig. 13).
- (2) Remove screw at armrest.
- (3) Remove screw at the upper mirror bezel.
- (4) Remove the screw in the trim panel depression.
- (5) Using trim remover (C-4829 or equivalent), detach trim panel perimeter push-in fasteners from door inner panel.

REMOVAL AND INSTALLATION (Continued)

(6) If equipped, disconnect the wiring connectors from power switch panel.

(7) Lift trim panel over inside release handle and remove trim panel from door.

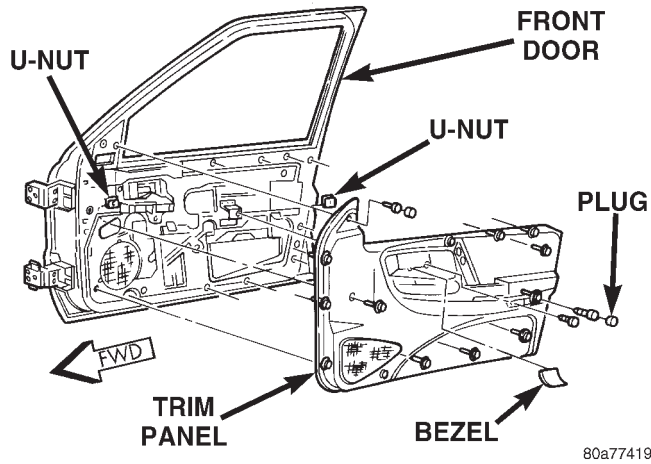


Fig. 13 Front Door Trim Panel

INSTALLATION

- (1) If equipped, connect the wiring connectors to power switch panel.
- (2) Position trim panel on door inner panel.
- (3) Press push-in fasteners inward around perimeter of door to attach it to inner panel.
- (4) Install armrest screw.
- (5) Install mirror bezel screw.
- (6) Install the screw in the trim panel depression.
- (7) Install screw attaching trim panel to inside release handle.

FRONT DOOR WATERDAM**REMOVAL**

- (1) Remove the door trim panel.
- (2) Peel the insulator and waterdam from the door.
- (3) Route all harnesses through waterdam as necessary.
- (4) Separate insulator and waterdam from door (Fig. 14).

INSTALLATION

- (1) Waterdam contact surface must be free of contaminants. Clean as necessary.
- (2) Route all harnesses through waterdam as necessary.
- (3) Position waterdam and insulator on door and align all holes.
- (4) Press waterdam and insulator on door.
- (5) Install the door trim panel.

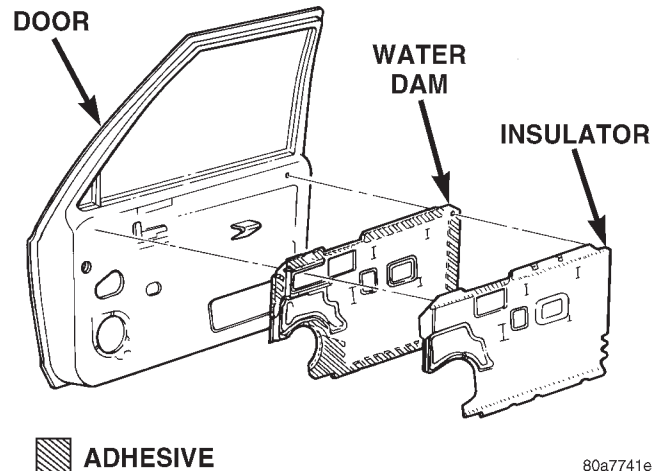


Fig. 14 Waterdam-Insulator

FRONT DOOR**REMOVAL**

- (1) Remove trim panel.
- (2) If equipped, disconnect power window regulator, power door lock motor and all other wire harness connectors.
- (3) Slide wire harness out of boot and door
- (4) Mark an outline around door hinges for installation alignment reference.
- (5) Remove door hinge, retaining bolts, plates and shims (Fig. 15).
- (6) Identify and retain door hinge plates and shims for correct installation.
- (7) Separate door from vehicle.

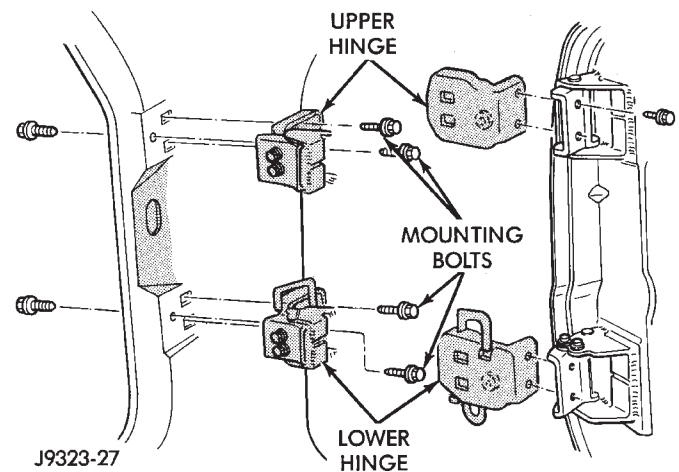


Fig. 15 Door Hinges and Bolts

INSTALLATION

- (1) If a replacement front door is being installed, coat door interior with anti-corrosion wax. Also, seal door hem flange with sealant.
- (2) Transfer original hardware. If necessary, refer to applicable procedures.

REMOVAL AND INSTALLATION (Continued)

- (3) Position door in body opening.
- (4) Align door hinges, plates and shims with bolt holes. Install (but do not tighten) hinge bolts.
- (5) Adjust door to reference marks. If necessary, refer to adjustment procedure. Tighten hinge bolts to 35 N·m (26 ft-lbs) torque.
- (6) Adjust latch striker as necessary.
- (7) If applicable, route and connect harness connectors to door and vehicle body wire harness connectors.
- (8) Install door waterdam (if removed), trim panel.

FRONT DOOR HINGE

REMOVAL

- (1) Open and support door.
- (2) Remove bolts attaching hinge to B-pillar (Fig. 16).
- (3) Separate door from vehicle.

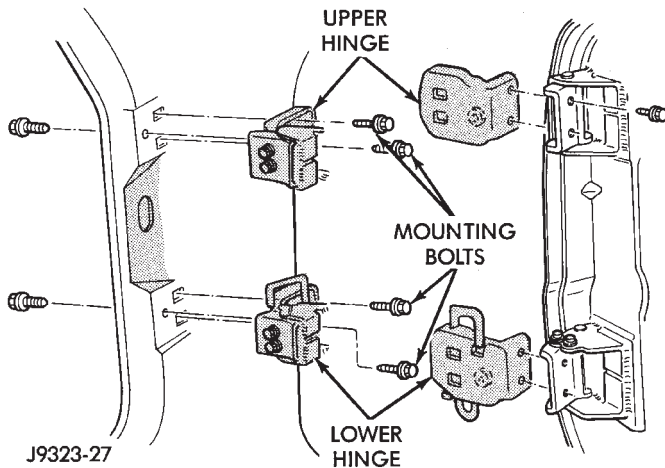


Fig. 16 Front Door Hinge

INSTALLATION

- (1) Support door.
- (2) Position door at B-pillar.
- (3) Install bolts attaching hinge to B-pillar. Tighten outer bolts to 40 N·m (360 in. lbs.) and inner bolts 34 N·m (300 in. lbs.) torque.

FRONT DOOR OUTSIDE HANDLE

REMOVAL

- (1) Remove door trim panel and waterdam.
- (2) Remove access hole cover and door handle retaining nuts.
- (3) Disconnect handle latch rod from latch (Fig. 17).

INSTALLATION

- (1) Reverse removal procedure.

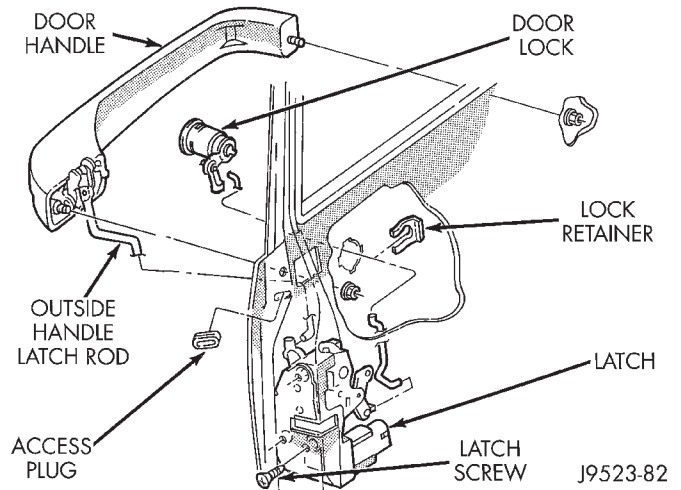


Fig. 17 Front Door Outside Handle

FRONT DOOR LOCK CYLINDER

REMOVAL

- (1) Remove door trim panel and waterdam. If necessary, refer to removal procedure.
- (2) Disconnect door latch lock cylinder rod at door latch (Fig. 17).
- (3) If equipped, disconnect security alarm switch connector from lock cylinder (Fig. 18).
- (4) Remove key lock cylinder retainer clip. Remove lock cylinder, gasket and clip from door.
- (5) If applicable, remove door latch lock cylinder rod from original lock cylinder. Connect it to replacement lock cylinder.

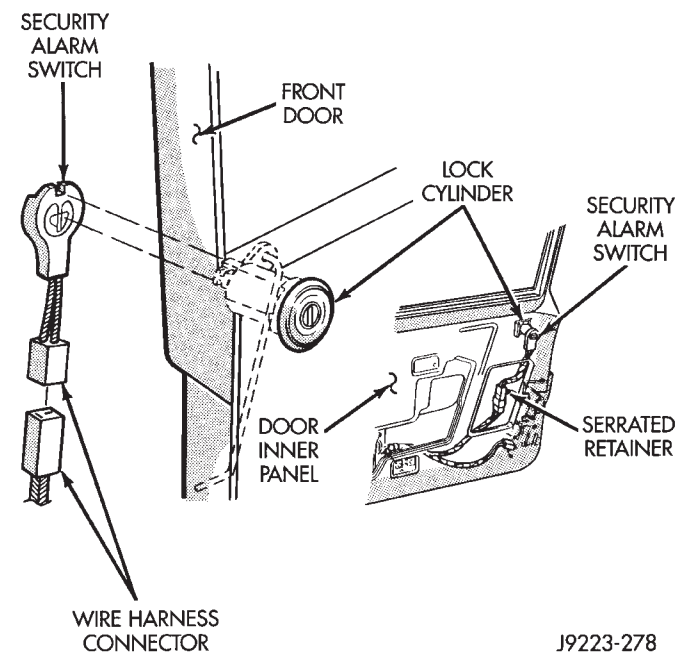


Fig. 18 Security Alarm Switch

REMOVAL AND INSTALLATION (Continued)**INSTALLATION**

- (1) Reverse removal procedure.

FRONT DOOR LATCH**REMOVAL**

- (1) Remove door trim panel and waterdam.
- (2) Remove door latch retaining screws (Fig. 19).
- (3) Disconnect all rods from door latch (Fig. 20).
- (4) Disconnect wire connector, if equipped.
- (5) Remove door latch from door.

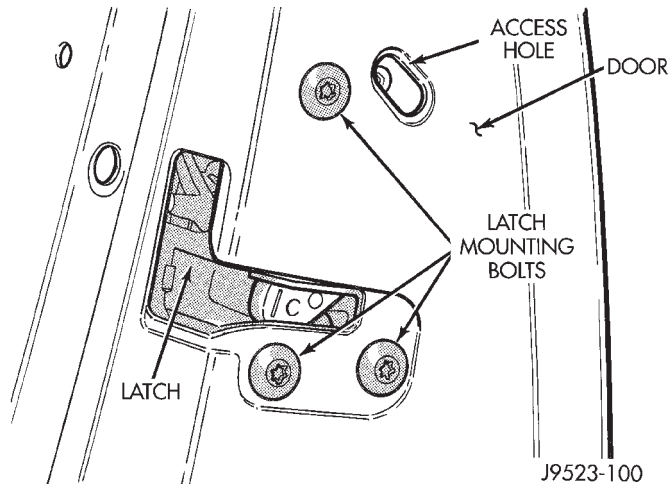


Fig. 19 Door Latch Removal

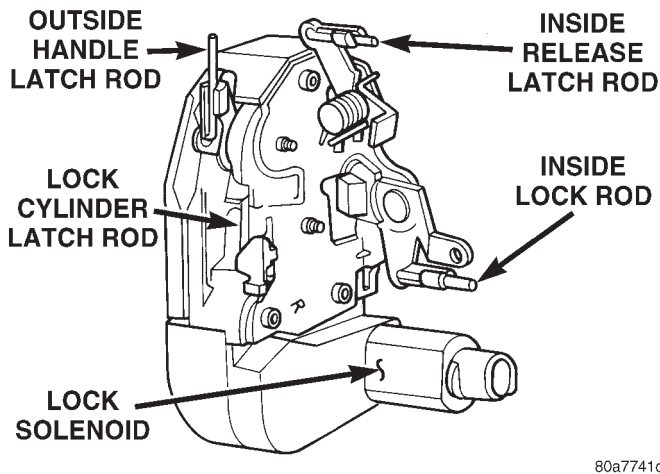


Fig. 20 Door Latch

INSTALLATION

- (1) Reverse removal procedure. Tighten latch screws to 10 N·m (95 in. lbs.) torque.

FRONT DOOR LATCH STRIKER**REMOVAL**

- (1) Remove screws attaching striker to B-pillar.
- (2) Separate striker from B-pillar.

INSTALLATION

- (1) Position striker on B-pillar.
- (2) Install screws attaching striker to B-pillar. Tighten screws to 5 N·m (45 in. lbs.) torque.

FRONT DOOR INSIDE HANDLE ACTUATOR**REMOVAL**

- (1) Remove door trim panel and waterdam. If necessary, refer to removal procedure.
- (2) Remove door inside latch release handle screws (Fig. 21).
- (3) Move door release handle outward. Disconnect handle latch and lock rods.
- (4) Remove door inside handle actuator from door.

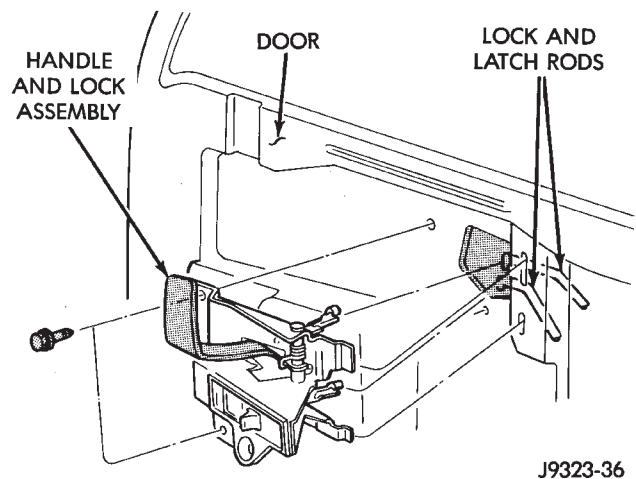


Fig. 21 Front Door Inside Handle Actuator

INSTALLATION

- (1) Reverse removal procedure.

FRONT DOOR INNER BELT SEAL**REMOVAL**

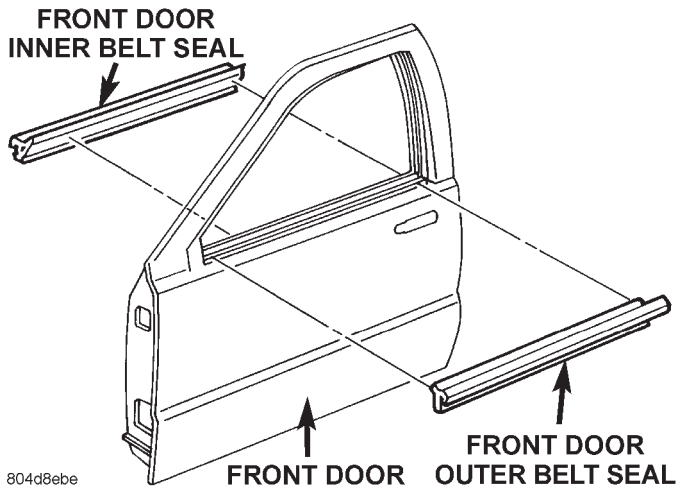
- (1) Remove door trim panel.
- (2) Using a trim stick, carefully pry rear inner edge of seal upward.
- (3) Grasp seal and pull upward to separate from door flange (Fig. 22).

INSTALLATION

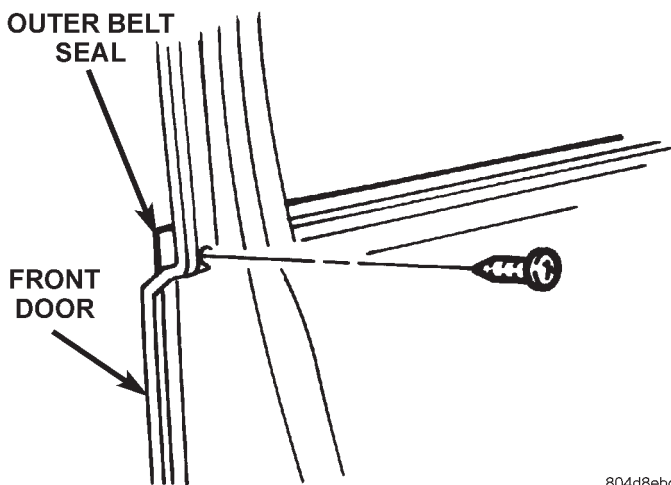
- (1) Position seal on door flange.
- (2) Firmly press downward to seat seal on flange.
- (3) Install trim panel.

FRONT DOOR OUTER BELT SEAL**REMOVAL**

- (1) Lower window glass.
- (2) Remove screw from inner door panel attaching seal to outer door panel (Fig. 23).

REMOVAL AND INSTALLATION (Continued)**Fig. 22 Front Door Inner Belt Seal**

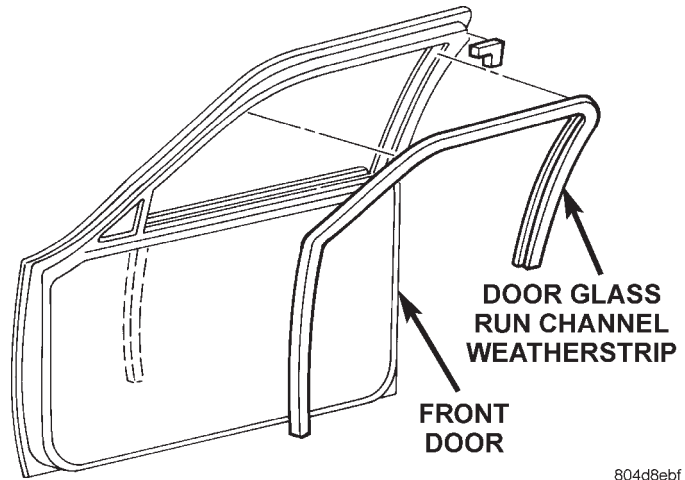
- (3) Grasp seal and pull rearward to release it from side view mirror bezel.
- (4) Lift seal upward and separate from door.

**Fig. 23 Front Door Outer Belt Seal****INSTALLATION**

- (1) Lightly lubricate the front of the seal
- (2) Position the seal onto the door flange.
- (3) Slide the front of the seal behind the side view mirror bezel. Force the seal onto door flange. Continue rearward until it is seated on flange.
- (4) Install the screw securing the seal to the outer door panel.

FRONT DOOR RUN CHANNEL WEATHERSTRIP**REMOVAL**

- (1) Lower window glass.
- (2) Grasp seal from upper run channel corner and firmly separate weatherstrip from flange (Fig. 24).

**Fig. 24 Front Door Glass Run Channel Weatherstrip INSTALLATION**

NOTE: Soapy water may be used to aid in installation.

- (1) Position weatherstrip on flange aligning notches in each corner.
- (2) Press weatherstrip into position.

FRONT DOOR OPENING WEATHERSTRIP**REMOVAL**

- (1) Remove A-pillar trim panel.
- (2) Remove B-pillar upper trim panel.
- (3) Remove B-pillar lower trim panel.
- (4) Grasp seal and separate from door opening.

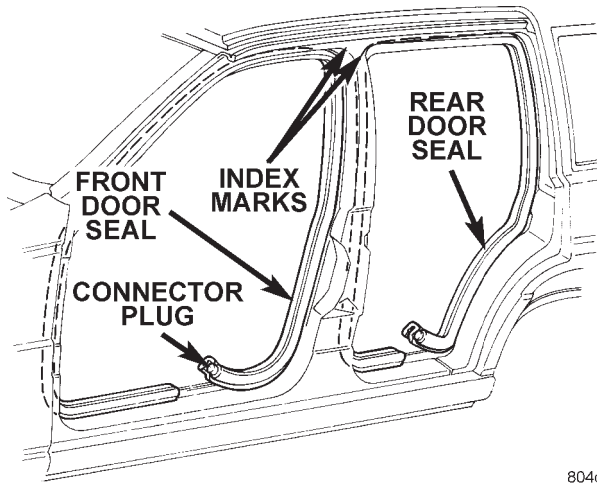
INSTALLATION

- (1) Position weatherstrip at corners using paint dots as alignment points.
- (2) Move upward and around edge of door opening. Seat seal on flange (Fig. 25).
- (3) Engage connector plug with each end of weatherstrip at bottom of door opening.
- (4) Install B-pillar lower trim panel.
- (5) Install B-pillar upper trim panel.
- (6) Install A-pillar trim panel.

FRONT DOOR WINDOW REGULATOR**REMOVAL**

- (1) Remove door trim panel and waterdam. If necessary, refer to removal procedure.
- (2) Position window glass to access window track nuts (Fig. 26).
- (3) Loosen window track nuts and slide track off of the window.
- (4) Remove window regulator retaining screws (Fig. 27).

REMOVAL AND INSTALLATION (Continued)



804d8ebb

Fig. 25

(5) Lift window upward and separate it from regulator. Support window.

(6) Remove window regulator from door.

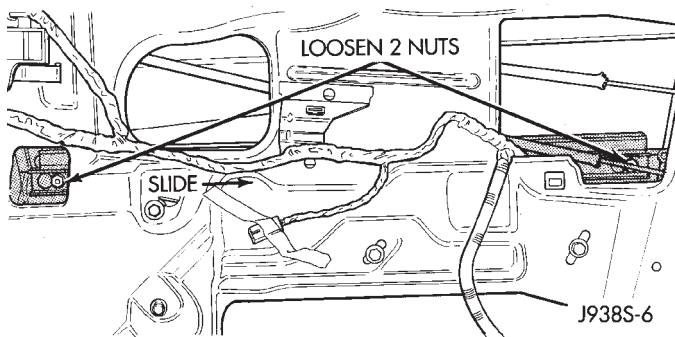


Fig. 26 Front Door Window Track

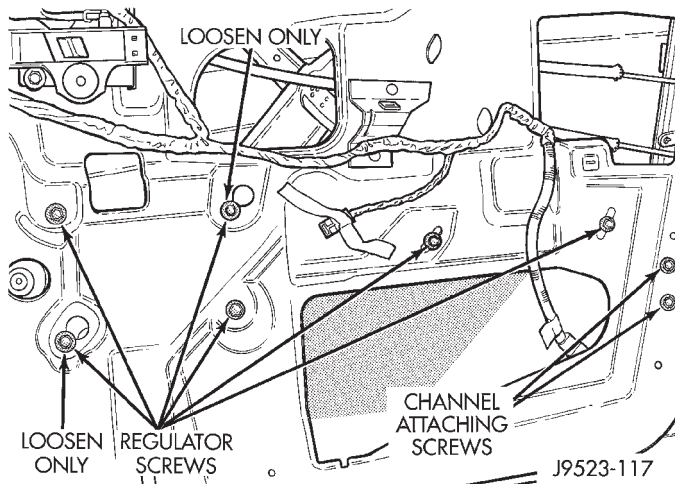


Fig. 27 Front Door Window Regulator

INSTALLATION

(1) Reverse removal procedure.

FRONT DOOR WINDOW GLASS**REMOVAL**

(1) Remove door trim panel and waterdam. If necessary, refer to removal procedure.

(2) Remove beltline molding and weatherstrip seals.

(3) Remove window track retaining nuts.

(4) Lift window glass upward and out of door.

INSTALLATION

(1) Lower window glass into position.

(2) Install window track retaining nuts.

(3) Install beltline molding and weatherstrip seals.

(4) Install door trim panel and waterdam.

REAR DOOR TRIM PANEL**REMOVAL**

(1) Remove screw attaching trim panel to inside release handle (Fig. 28).

(2) Remove screw at armrest.

(3) Using trim remover (C-4829 or equivalent), detach trim panel perimeter push-in fasteners from door inner panel.

(4) If equipped, disconnect the wiring connectors from power switch panel.

(5) Lift trim panel over inside release handle and remove trim panel from door.

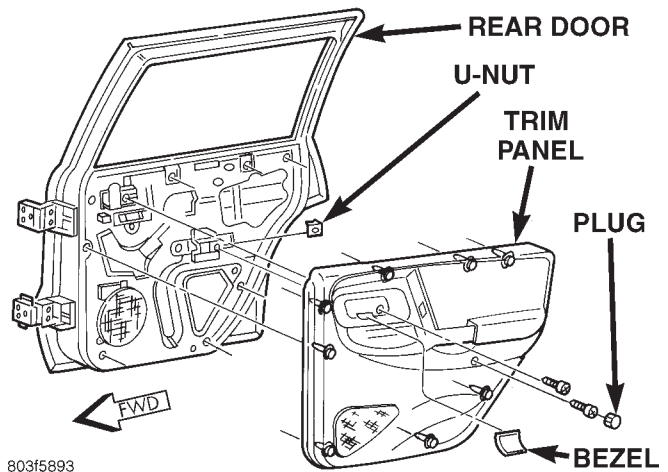


Fig. 28 Rear Door Trim Panel

INSTALLATION

(1) If equipped, connect the wiring connectors to power switch panel.

(2) Position trim panel on door inner panel.

(3) Press push-in fasteners inward around perimeter of door to attach it to inner panel.

(4) Install armrest screw.

(5) Install mirror bezel screw.

(6) Install screw attaching trim panel to inside release handle.

REMOVAL AND INSTALLATION (Continued)

REAR DOOR

REMOVAL

- (1) Remove door trim panel.
- (2) Disconnect power window regulator, power door lock motor and all other wire harness connectors.
- (3) Slide wire harness out of boot and door.
- (4) Mark an outline around door hinges for installation alignment reference.
- (5) Remove door hinge, retaining bolts, plates and shims (Fig. 29). Remove door from vehicle.
- (6) Identify and retain door hinge plates and shims for correct installation.

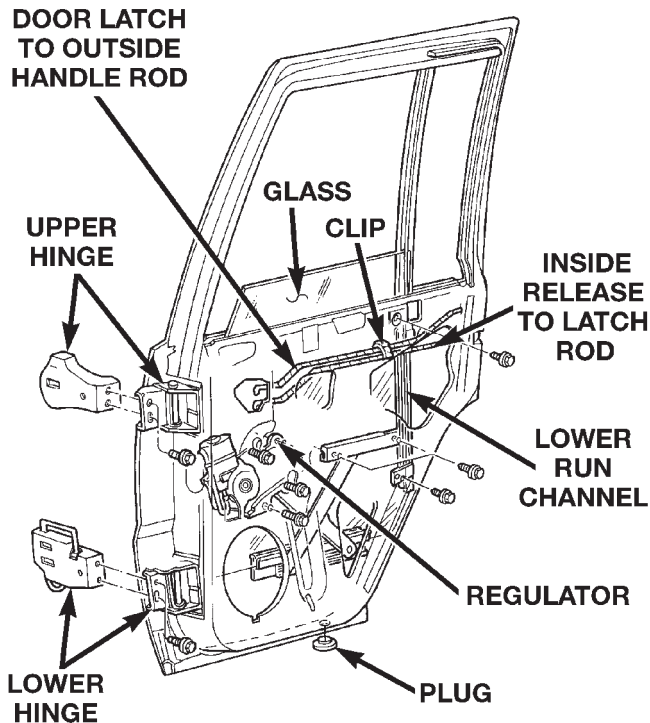


Fig. 29 Rear Door

INSTALLATION

- (1) If a replacement front door is being installed, coat door interior with anti-corrosion wax. Also, seal door hem flange with sealant.
- (2) Before installing a replacement door, transfer original hardware. If necessary, refer to applicable procedures.
- (3) Position door in body opening.
- (4) Align door hinges, plates and shims with bolt holes. Install (but do not tighten) hinge bolts.
- (5) Adjust door to reference marks. If necessary, refer to adjustment procedure. Tighten hinge bolts to 28 N·m (250 in. lbs.) torque.
- (6) Adjust latch striker as necessary.
- (7) If applicable, route and connect harness connectors to door and vehicle body wire harness connectors.

- (8) Install door waterdam (if removed), trim panel, armrest and window glass regulator handle.

REAR DOOR HINGE

REMOVAL

- (1) Open and support door.
- (2) Remove bolts attaching hinge to C-pillar (Fig. 30).
- (3) Separate door from vehicle.

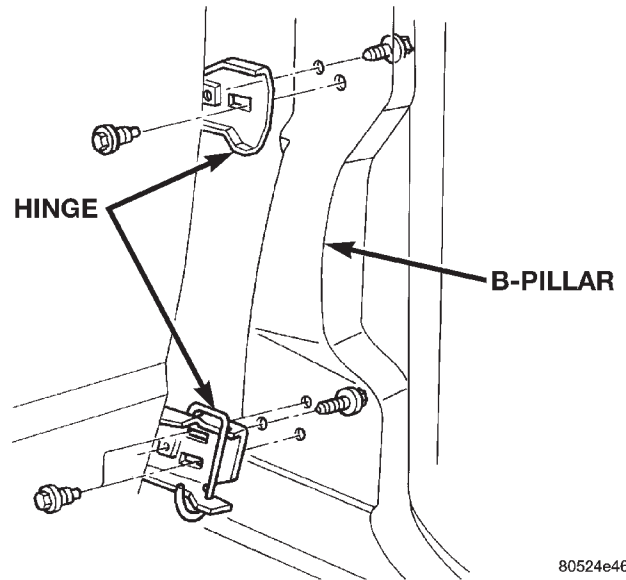


Fig. 30 Rear Door Hinge

INSTALLATION

- (1) Support door.
- (2) Position door at C-pillar.
- (3) Install bolts attaching hinge to C-pillar. Tighten outer bolts to 40 N·m (360 in. lbs.) and inner bolts 34 N·m (300 in. lbs.) torque.

REAR DOOR OUTSIDE HANDLE

REMOVAL

- (1) Remove door trim panel and waterdam. If necessary, refer to removal/installation procedure.
- (2) Remove access hole cover and door handle retaining nuts (Fig. 31).
- (3) Disconnect handle latch rod from latch.

INSTALLATION

- (1) Reverse removal procedure.

REAR DOOR LATCH

REMOVAL

- (1) Remove door trim panel and waterdam. If necessary, refer to removal procedure.
- (2) Remove door latch retaining screws (Fig. 31).
- (3) Disconnect all rods from door latch.

REMOVAL AND INSTALLATION (Continued)

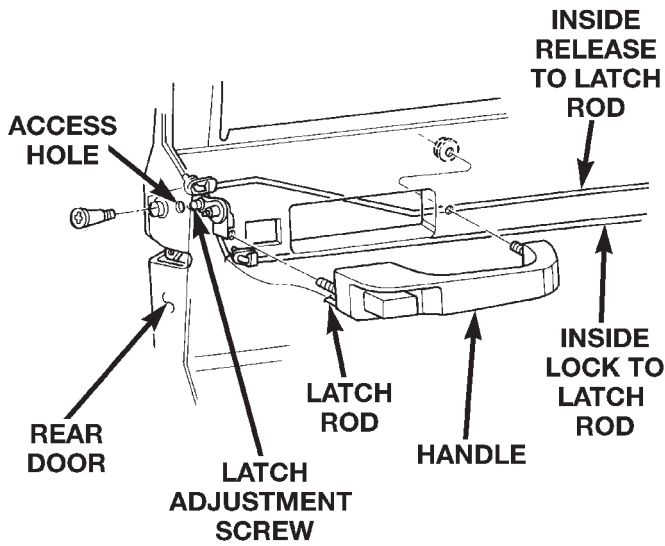


Fig. 31 Rear Door Outside Handle

- (4) Remove door latch from door.

INSTALLATION

- (1) Reverse removal procedure.

REAR DOOR LATCH STRIKER**REMOVAL**

- (1) Open door.
- (2) Remove screws attaching striker to C-pillar (Fig. 32).
- (3) Separate striker and spacer from vehicle.

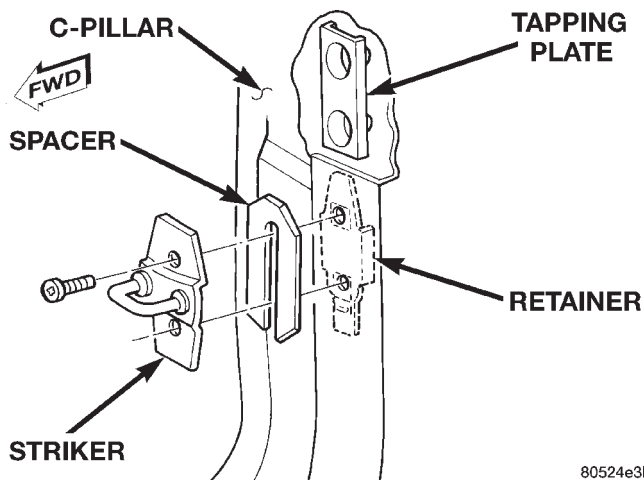


Fig. 32 Rear Door Latch Striker

INSTALLATION

- (1) Position striker and spacer on C-pillar.
- (2) Install screws. Tighten to 28 N·m (250 in. lbs.) torque.

REAR DOOR INSIDE HANDLE ACTUATOR**REMOVAL**

- (1) Remove door trim panel and waterdam.
- (2) Remove door inside handle actuator screws (Fig. 33).
- (3) Move actuator handle outward. Disconnect handle latch and lock rods.
- (4) Remove door inside release handle from door.

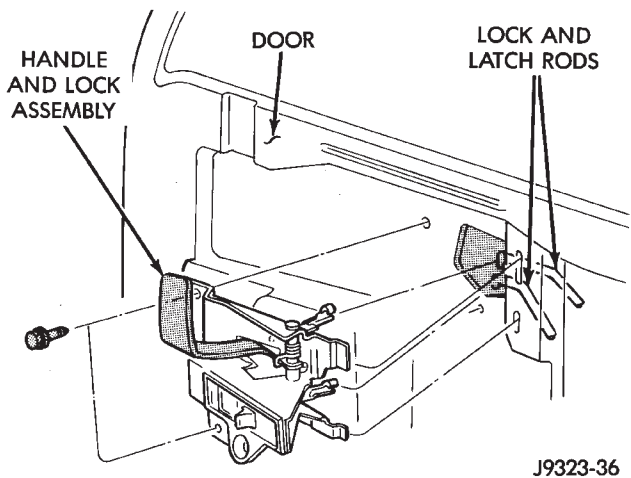


Fig. 33 Rear Door Inside Latch Release Handle

INSTALLATION

- Reverse removal procedure.

REAR DOOR INNER BELT SEAL**REMOVAL**

- (1) Remove door trim panel.
- (2) Using a trim stick, carefully pry rear inner edge of seal upward.
- (3) Grasp seal and pull upward to separate from door flange (Fig. 34).

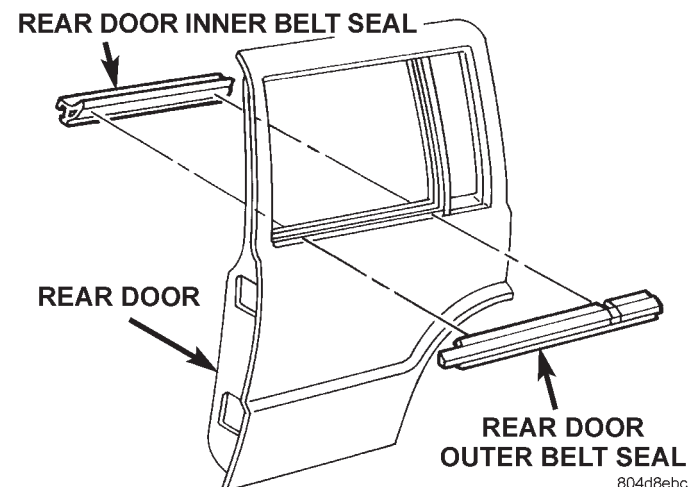


Fig. 34 Rear Door Inner Belt Seal

REMOVAL AND INSTALLATION (Continued)

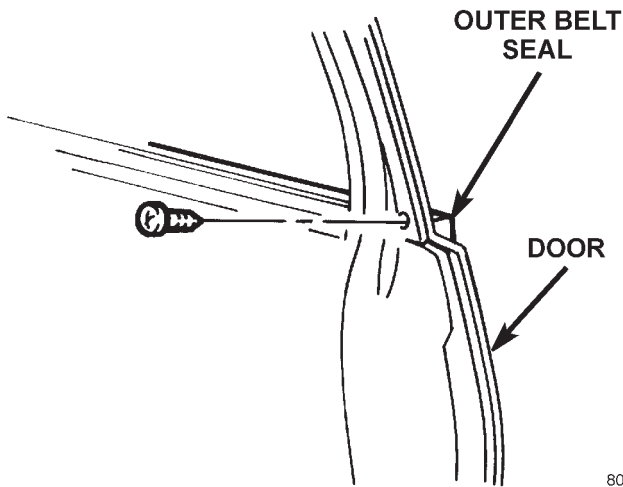
INSTALLATION

- (1) Position seal on door flange.
- (2) Firmly press downward to seat seal on flange.
- (3) Install trim panel.

REAR DOOR OUTER BELT SEAL

REMOVAL

- (1) Lower window glass.
- (2) Remove screw from inner door panel attaching seal to outer door panel (Fig. 35).
- (3) Lift seal upward and separate from door.



804d8ec2

Fig. 35 Rear Door Outer Belt Seal

INSTALLATION

- (1) Position the seal onto the door flange.
- (2) Tuck outer belt sealing lips inside glass run channel and around division bar.
- (3) Force the seal onto door flange. Continue rearward until it is seated on flange.
- (4) Install the screw securing the seal to the outer door panel.

REAR DOOR OPENING WEATHERSTRIP

REMOVAL

- (1) Remove C-pillar trim panel.
- (2) Remove B-pillar upper trim panel.
- (3) Remove B-pillar lower trim panel.
- (4) Remove screws at the front of the quarter trim panel.
- (5) Grasp seal and separate from door opening.

INSTALLATION

- (1) Position weatherstrip at corners using paint dots as alignment points.
- (2) Move upward and around edge of door opening. Seat seal on flange (Fig. 25).
- (3) Engage connector plug with each end of weatherstrip at bottom of door opening.

- (4) Install screws at the front of the quarter trim panel.
- (5) Install B-pillar lower trim panel.
- (6) Install B-pillar upper trim panel.
- (7) Install C-pillar trim panel.

REAR DOOR WINDOW REGULATOR

REMOVAL

- (1) Remove door trim panel and waterdam. If necessary, refer to removal procedure.
- (2) Position window glass to access window track nuts (Fig. 36).
- (3) Loosen window track nuts and slide track off of window.
- (4) Remove window regulator retaining screws (Fig. 37).
- (5) Lift window upward and separate it from regulator. Support window.
- (6) Remove window regulator from door.

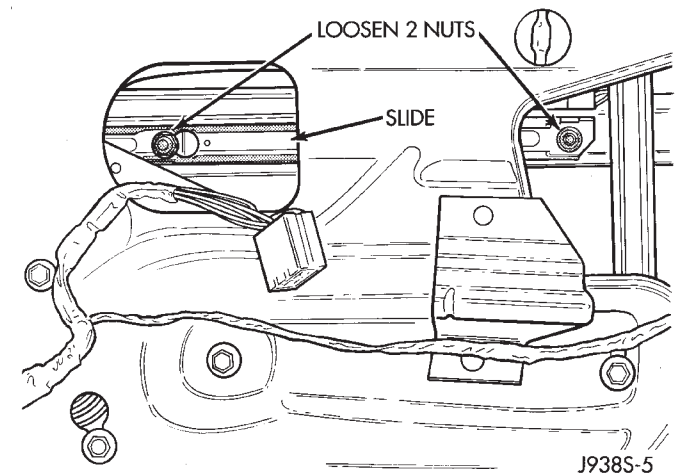


Fig. 36 Rear Door Window Track

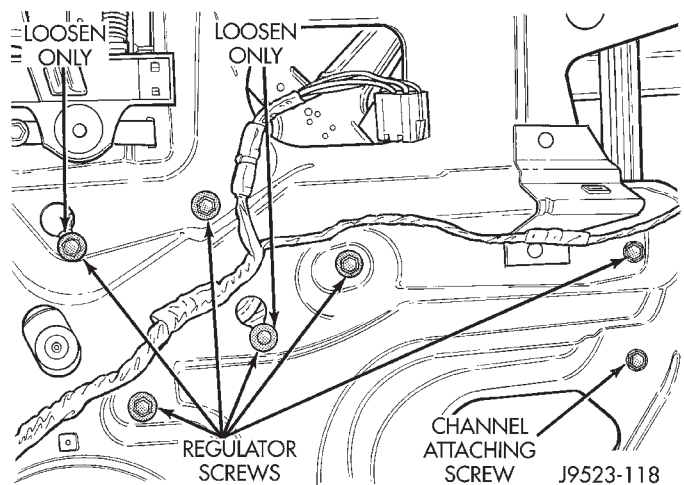


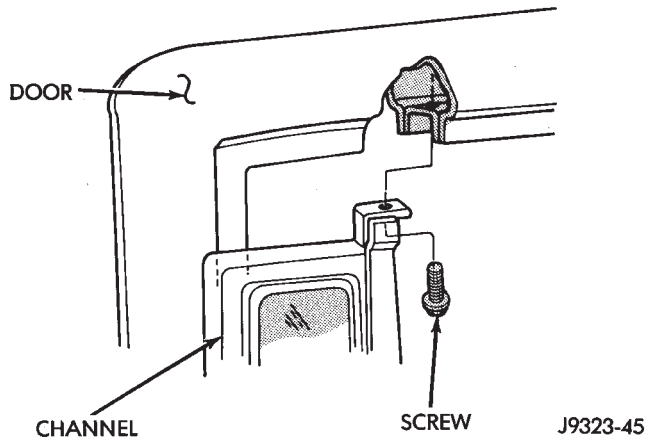
Fig. 37 Rear Door Window Regulator

REMOVAL AND INSTALLATION (Continued)**INSTALLATION**

- (1) Reverse removal procedure.

REAR DOOR WINDOW GLASS**REMOVAL**

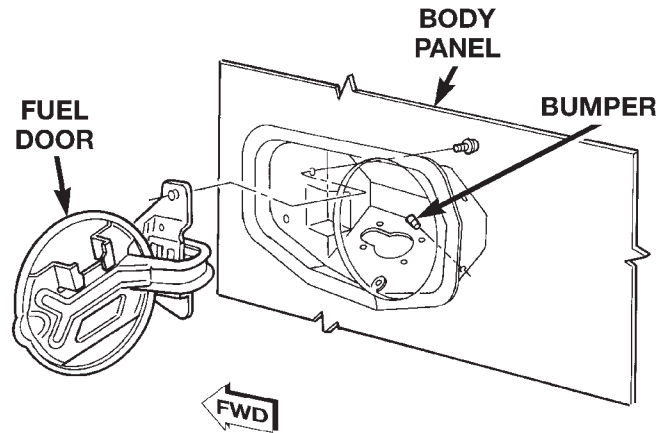
- (1) Lower window glass.
- (2) Remove trim panel and waterdam from door inner panel. If necessary, refer to removal procedure.
- (3) Pry window beltline molding from flange. Remove molding from door.
- (4) Remove window weatherstrip seals from door.
- (5) Remove window track nuts and slide track off of window.
- (6) Remove division bar upper attaching screw and belt line screw (Fig. 38).
- (7) Tilt stationary glass channel assembly forward and remove it from door.
- (8) Remove window glass from door.

**Fig. 38 Glass Channel****INSTALLATION**

- (1) Install window glass in door.
- (2) Tighten glass track nuts to 6 N-m (53 in-lbs) torque.
- (3) Install stationary glass channel in door.
- (4) Install stationary glass channel screws. Tighten screw to 6 N-m (5 ft-lbs) torque.
- (5) Install window glass channel and belt weatherstrip seals.
- (6) Install window beltline molding.
- (7) Install door waterdam and trim panel. If necessary, refer to installation procedure.

FUEL DOOR**REMOVAL**

- (1) Open fuel door.
- (2) Remove rear quarter trim panel.
- (3) Remove screw attaching fuel door to body panel (Fig. 39).
- (4) Separate fuel door from vehicle.



804d8edb

Fig. 39 Fuel Door**INSTALLATION**

- (1) Position fuel door at vehicle.
- (2) Install screw attaching fuel door to body panel.
- (3) Install rear quarter trim panel.
- (4) Close fuel door.

BODY SIDE CLADDING**REMOVAL—FRONT DOOR**

- (1) Using a trim stick, gently lift up from bottom of cladding. Unsnap molding from retaining clips (Fig. 40).
- (2) Lift upward and remove molding.

INSTALLATION—FRONT DOOR

- (1) Replace all retaining clips.
- (2) Install molding over top of retaining clips.
- (3) Align molding to door edges.
- (4) Snap molding down over retaining clips.

REMOVAL—REAR DOOR

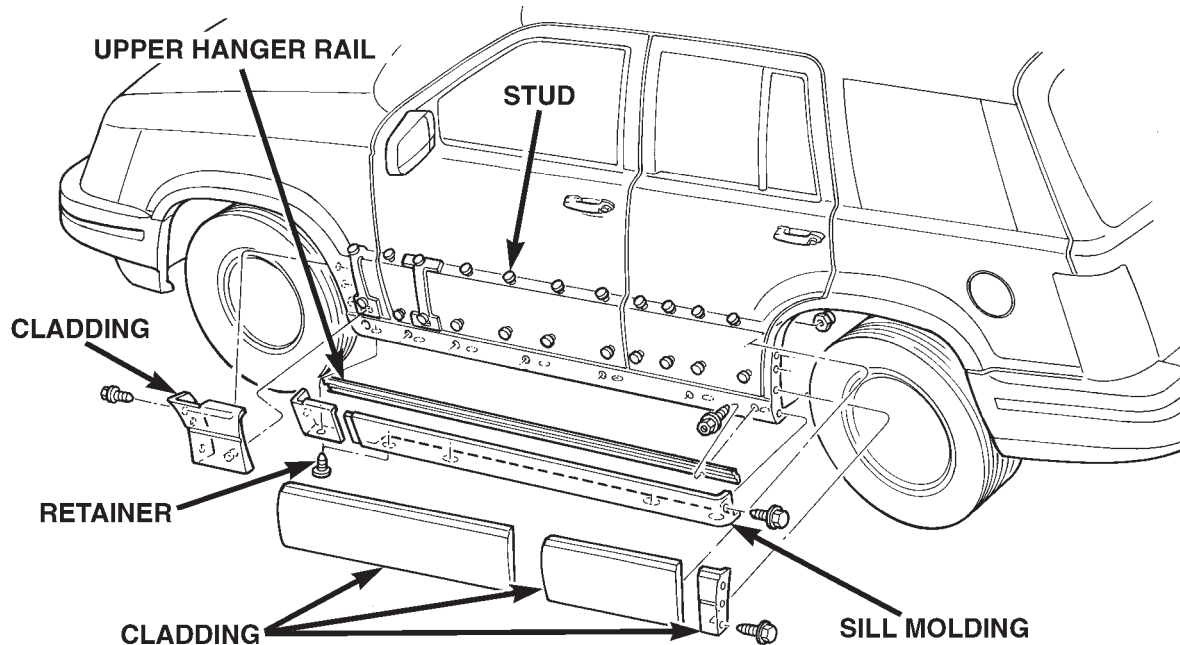
- (1) Open rear door.
- (2) Remove acorn nut at rear dogleg (Fig. 40).
- (3) Using a trim stick, gently lift up from bottom of cladding. Unsnap molding from retaining clips.

INSTALLATION—REAR DOOR

- (1) Replace all retaining clips.
- (2) Install molding retainer into hole at dogleg.
- (3) Install molding over top of retaining clips.
- (4) Snap molding down over top of retaining clips.
- (5) Install acorn nut onto retainer.

REMOVAL—FENDER/QUARTER PANEL

- (1) Remove screws at wheel opening.
- (2) Using a trim stick, Gently pry upward from bottom of cladding.
- (3) Unsnap cladding from retainers.

REMOVAL AND INSTALLATION (Continued)

803f58a8

Fig. 40 Body Side Cladding**INSTALLATION—FENDER/QUARTER PANEL**

- (1) Replace all retaining clips.
- (2) Install molding over top of retainer clips.
- (3) Snap molding down over retaining clips.
- (4) Install screws into wheel opening.

A-PILLAR TRIM**REMOVAL**

- (1) Using a trim stick, carefully pry A-pillar trim from A-pillar (Fig. 41).

INSTALLATION

- (1) Position A-pillar trim panel at A-pillar and snap into place.
- (2) Ensure that the A-pillar covers the inner edge of the door opening weatherstrip.

ASSIST HANDLE**REMOVAL**

- (1) Remove the screws attaching the handle to the headliner (Fig. 42).
- (2) Remove assist handle from roof panel.

INSTALLATION

- (1) Position handle on the roof panel.
- (2) Install the screws. Tighten screws to 3 N·m (22 in-lbs) torque.

FRONT DOOR SCUFF PLATE**REMOVAL**

The front door scuff plate is attached with molded-in snap retainers.

- (1) Using a trim stick or similar tool, carefully pry scuff plate from sill. Detach scuff plate from sill (Fig. 43).

INSTALLATION

- (1) Position scuff plate on sill and snap into place.

UPPER B-PILLAR TRIM PANEL**REMOVAL**

- (1) Remove the A-pillar trim panel.
- (2) Remove front seat belt turning loop.
- (3) Detach and remove upper B-pillar trim panel.

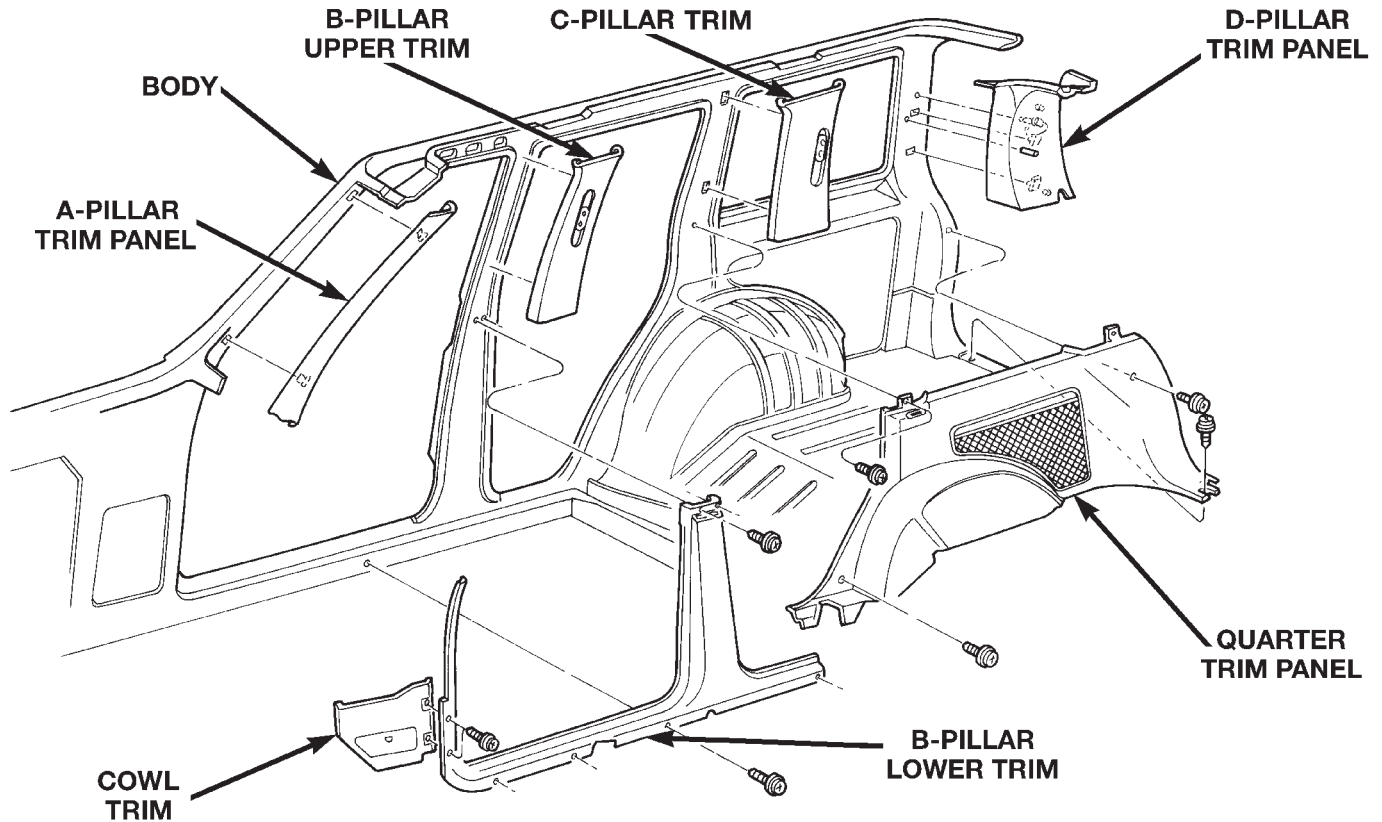
INSTALLATION

- (1) Position trim panel on B-pillar.
- (2) Ensure the trim panel covers the inner edge of the door opening weatherstrip.
- (3) Install front seat belt turning loop.
- (4) Install the A-pillar trim panel.

LOWER B-PILLAR TRIM PANEL**REMOVAL**

- (1) Remove the A-pillar trim panel.
- (2) Remove upper B-pillar trim panel.
- (3) Remove screws attaching lower B-pillar trim panel to B-pillar (Fig. 44).
- (4) Remove screws attaching cowl trim panel.

REMOVAL AND INSTALLATION (Continued)



80500536

Fig. 41 Trim Panels

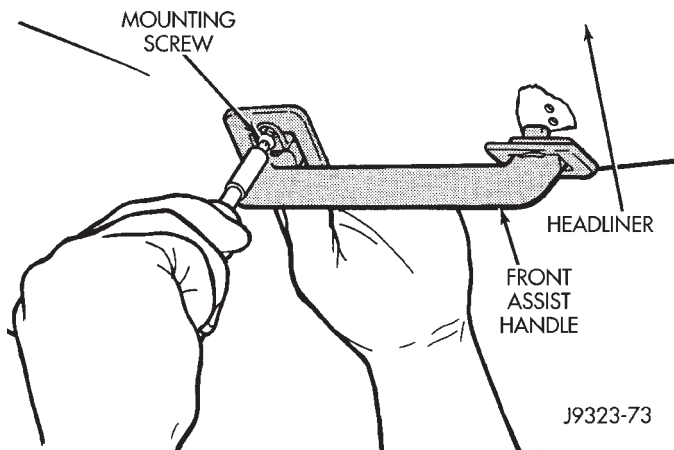


Fig. 42 Assist Handle

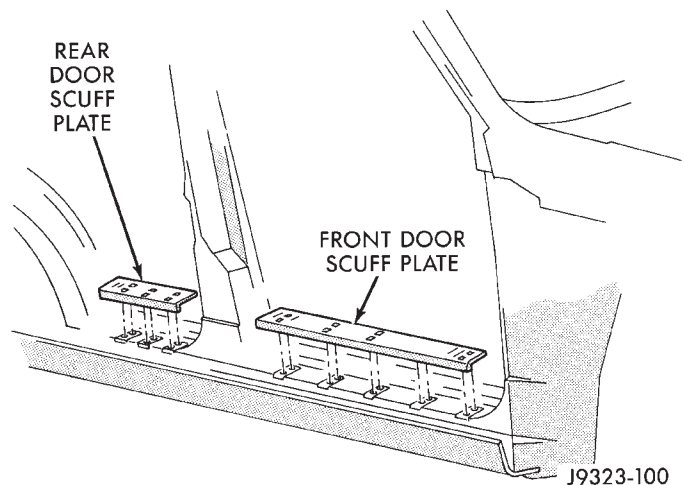


Fig. 43 Scuff Plates

- (5) Separate lower B-pillar trim panel from B-pillar.
- (6) Route seat/shoulder belt through access slot in lower B-pillar trim panel.
- (7) Remove lower B-pillar trim panel (Fig. 41).

INSTALLATION

- (1) Position lower B-pillar trim panel on vehicle.
- (2) Route seat/shoulder belt through access slot in lower B-pillar trim panel.

- (3) Install screws that attach lower B-pillar trim panel to B-pillar.
- (4) Install screws attaching cowl trim panel.
- (5) Slide upper B-pillar trim panel downward into place.
- (6) Install the A-pillar trim panel.

REMOVAL AND INSTALLATION (Continued)

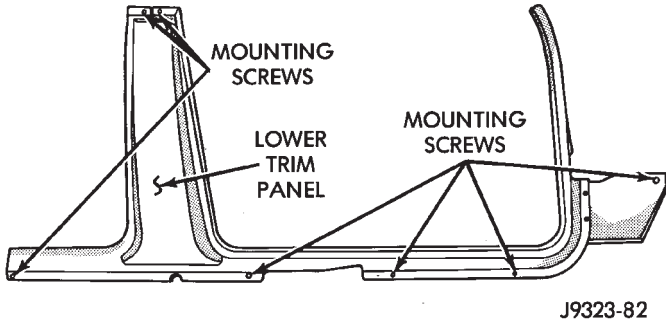


Fig. 44 B-Pillar Trim Panel

REAR DOOR SCUFF PLATE

REMOVAL

The rear door scuff plate is attached with molded-in snap retainers.

(1) Using a trim stick or similar tool, carefully pry scuff plate from sill. Detach scuff plate from sill (Fig. 43).

INSTALLATION

(1) Position scuff plate on sill and snap into place.

C-PILLAR TRIM

REMOVAL

(1) Remove rear seat belt turning loop.
 (2) Using a trim stick, carefully pry C-pillar trim panel from vehicle (Fig. 41).

INSTALLATION

(1) Position C-pillar trim panel on C-pillar. Ensure the adjustable turning loop is aligned with the trim panel slider and snap into place.
 (2) Install rear seat belt turning loop.

QUARTER TRIM PANELS

- (1) Pull rear seat bottom forward and fold down rear seat.
- (2) Remove lower retaining screw at rear door opening (Fig. 41).
- (3) If equipped, remove sunshade cover.
- (4) Remove C-pillar trim panel.
- (5) Remove screws retaining upper liftgate opening trim panel.
- (6) Disconnect wiring to cargo lamp.
- (7) Remove lower liftgate opening trim panel.
- (8) Remove D-pillar upper trim panel.
- (9) Remove quarter trim panel mounting screws.
- (10) If necessary, remove spare tire and tire stand-offs from left quarter trim panel (Fig. 45).
- (11) Remove rear quarter trim panel.

INSTALLATION

(1) Reverse removal procedure.

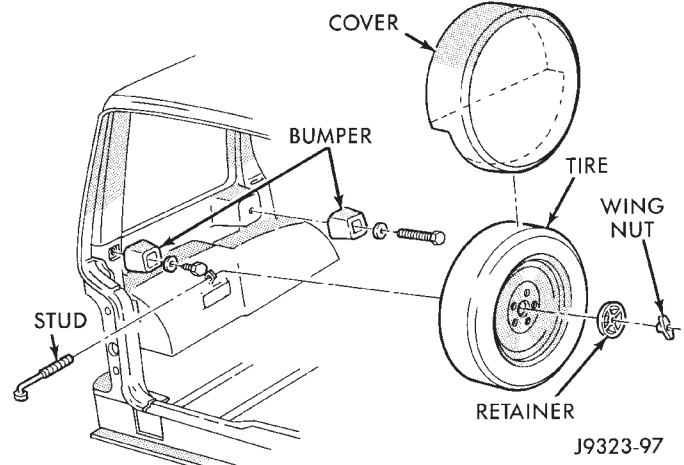


Fig. 45 Tire Stand-Offs—Left Quarter Trim Panel

D-PILLAR TRIM

REMOVAL

- (1) Remove liftgate opening upper trim panel (Fig. 46).
- (2) Detach and remove trim panel from D-pillar (Fig. 41).

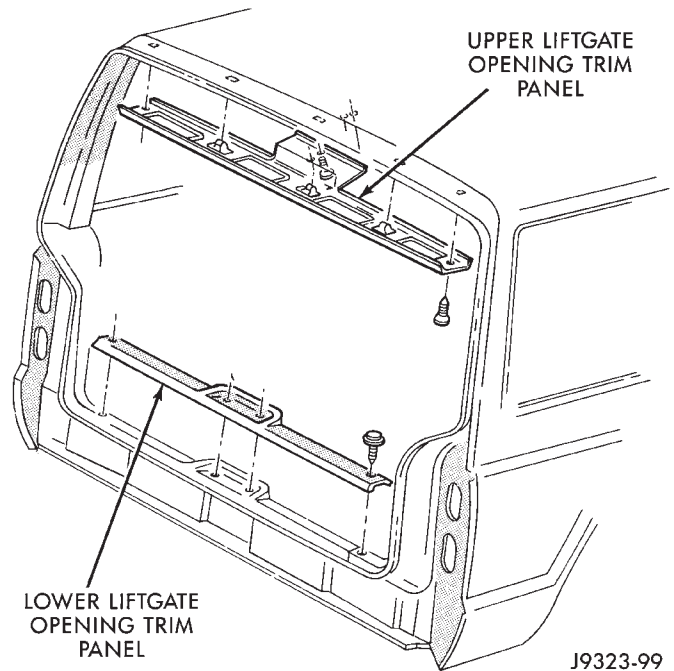


Fig. 46 Liftgate Opening Trim Panels

INSTALLATION

- (1) Position D-pillar trim panel on D-pillar and snap in place.
- (2) Install upper liftgate opening trim panel.

REMOVAL AND INSTALLATION (Continued)**FRONT SHOULDER BELT/BUCKLE****REMOVAL—BUCKLE**

- (1) Slide front seats all the way forward for access to buckle anchor bolt.
- (2) Remove anchor bolt cover.
- (3) Remove buckle anchor bolt.
- (4) Remove shoulder belt buckle from transmission tunnel.

INSTALLATION—BUCKLE

- (1) Position seat belt buckle in position and anchor bolt.
- (2) Install anchor bolt cover.

REMOVAL—SHOULDER BELT

- (1) Unsnap turning loop cover.
- (2) Remove upper anchor bolt (Fig. 47).
- (3) Remove B-pillar trim panels.
- (4) Remove bolt attaching retractor to B-pillar.
- (5) Remove bolt attaching belt anchor to B-pillar.
- (6) Disconnect retractor wire harness connector.
- (7) Remove shoulder belt and retractor.

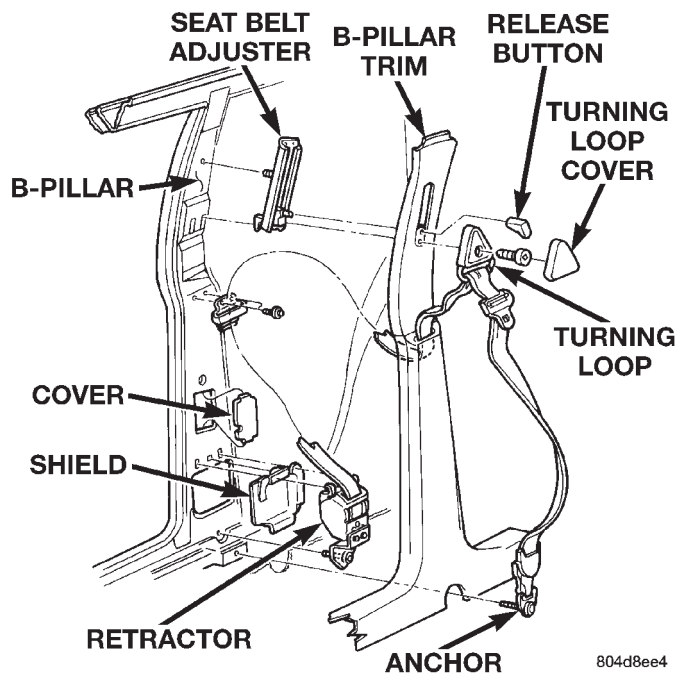


Fig. 47 Front Shoulder Belt

INSTALLATION—SHOULDER BELT

- (1) Reverse removal procedure. Tighten anchor bolts to 37 N·m (27 ft-lbs)

REAR SHOULDER/LAP BELT/BUCKLE**REMOVAL—LAP BELT/BUCKLE**

- (1) Pull rear seat release loop and tilt seat bottom forward. Remove seat bottom from lower latch.
- (2) Unlatch seat back and tilt forward.

- (3) Remove shoulder belt buckle and lap belt/buckle anchor plate bolts from the floor panel (Fig. 48).

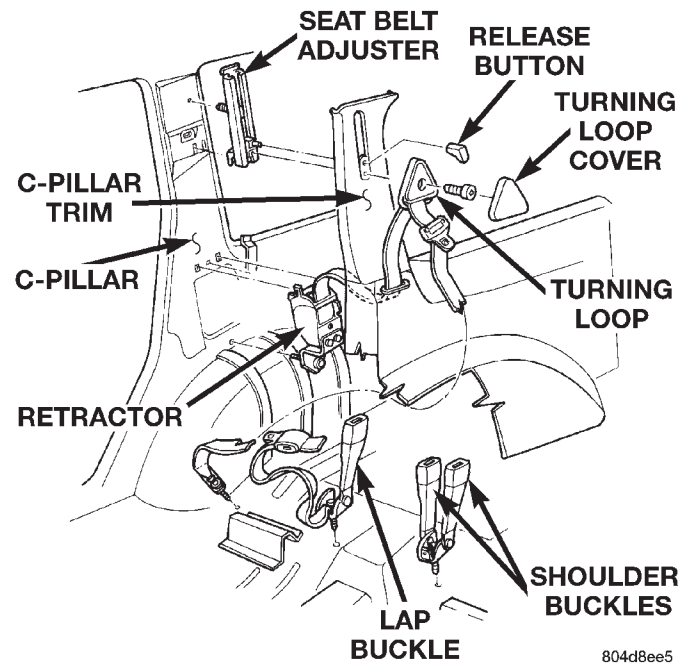


Fig. 48 Rear Seat Shoulder/Lap Belts & Buckles

INSTALLATION—LAP BELT/BUCKLE

- (1) Position shoulder belt buckle and lap belt/buckle on the floor panel.
- (2) Install bolts attaching lap belt/buckle to floor panel. Tighten anchor bolts to 37 N·m (27 ft-lbs).

REMOVAL—SHOULDER BELT

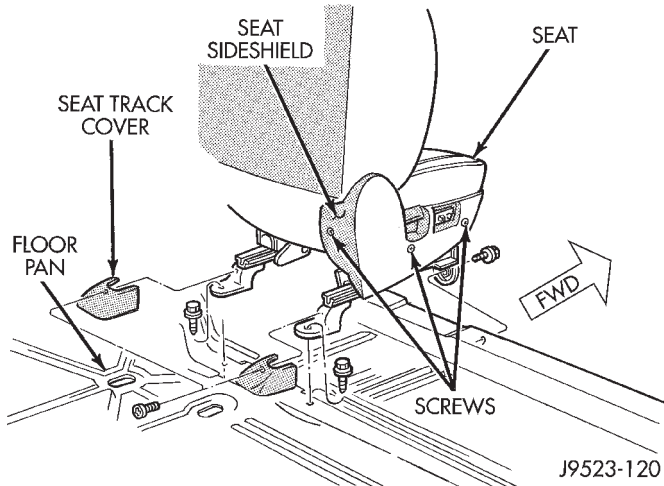
- (1) Unsnap turning loop cover.
- (2) Remove turning loop anchor bolt (Fig. 48).
- (3) Remove C-pillar and quarter trim panel.
- (4) Remove belt retractor anchor bolt from rear quarter rail.
- (5) Remove retractor and shoulder belt from panel.

INSTALLATION—SHOULDER BELT

- (1) Position retractor and shoulder belt on panel.
- (2) Install belt retractor anchor bolt in rear quarter rail. Tighten anchor bolts to 37 N·m (27 ft-lbs).
- (3) Install C-pillar and quarter trim panel.
- (4) Install turning loop anchor bolt. Tighten anchor bolt to 37 N·m (27 ft-lbs).
- (5) Install turning loop cover.

FRONT BUCKET SEAT**REMOVAL**

- (1) Remove bolts attaching seat to floor pan (Fig. 49).
- (2) If equipped, disconnect power seat wire harness connector.
- (3) Remove seat from floor panel.

REMOVAL AND INSTALLATION (Continued)**Fig. 49 Front Bucket Seat****INSTALLATION**

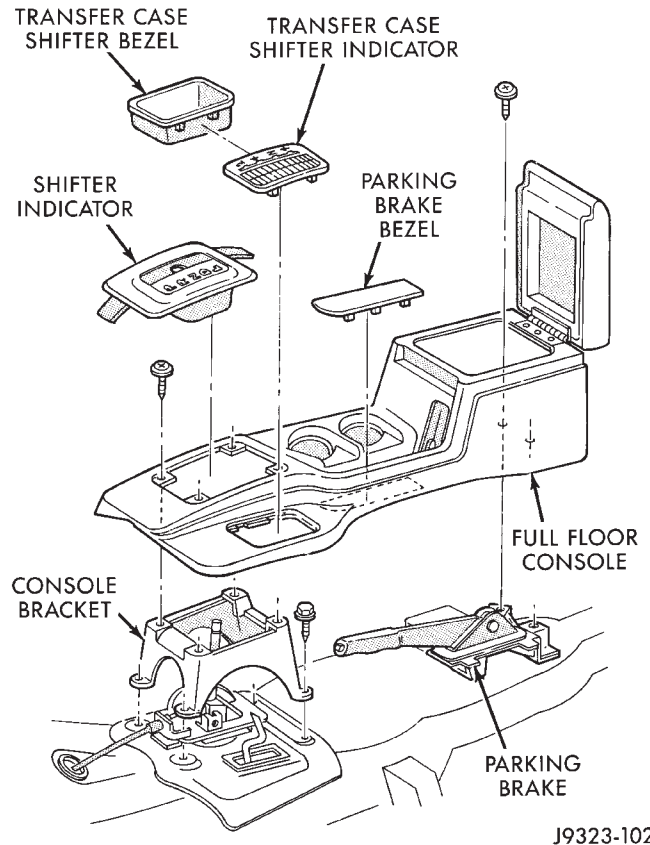
- (1) Position seat on floor pan.
- (2) If equipped, connect power seat wire harness connector.
- (3) Install bolts attaching seat to floor pan. Tighten front bolts to 27 N·m (20 ft. lbs.) torque, tighten rear bolts to 27 N·m (20 ft. lbs.) torque.

FLOOR CONSOLE**REMOVAL**

- (1) With the engine off, position the transmission shift lever in first gear.
- (2) Grasp transmission shift lever handle and firmly pull straight up.
- (3) Separate transmission shift lever handle from shift lever.
- (4) Remove transmission and transfer case shift indicator bezels by prying upward to release them. Position flat screwdriver between bezel and console to remove indicator bezel.
- (5) Disconnect lamp sockets from bezels.
- (6) Remove screws attaching console to the console bracket (Fig. 50).
- (7) Remove console from floor.

INSTALLATION

- (1) Position console in the vehicle.
- (2) Install screws attaching console to console bracket.
- (3) Connect lamp sockets in bezels.
- (4) Install transmission and transfer case shift indicator bezels (Fig. 50).
- (5) Position transmission shift lever handle on shift lever and press firmly downward to lock into place.

**Fig. 50 Console Components****REAR SEAT CUSHION****REMOVAL**

- (1) Disengage seat cushion at rear by pulling upward on release strap.
- (2) Tilt cushion forward.
- (3) Disengage seat cushion by pulling upward and out.
- (4) Remove seat cushion from vehicle.

INSTALLATION

- (1) Position seat cushion in vehicle.
- (2) Insert hinge into lower pivot.
- (3) Push downward to engage hinge into pivot.
- (4) Rotate cushion downward into seating position.
- (5) Lock seat cushion down by pressing firmly on center of cushion until latch engages.

REAR SEATBACK**REMOVAL**

- (1) Remove lower seat cushion. Refer to removal procedure.
- (2) Remove bolts holding seatback side support brackets (left side) (Fig. 51).
- (3) Tilt seatback forward, and slide it outboard to detach it from pin on center pivot bracket.
- (4) Remove left side (60%) seatback from vehicle.

REMOVAL AND INSTALLATION (Continued)

(5) Remove bolts holding seatback side support brackets (right side) (Fig. 51).

(6) Remove right side (40%) seatback from vehicle.

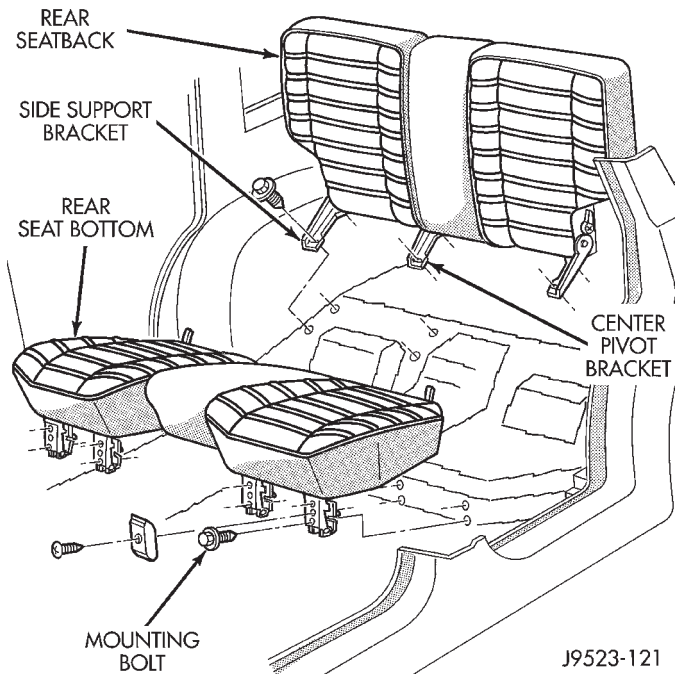


Fig. 51 Rear Seat Mounting

INSTALLATION

- (1) Position right side (40%) seatback in vehicle.
- (2) Position right side support brackets with bolt holes aligned and install support bracket bolts. Tighten bolts to 27 N·m (20 ft. lbs.) torque.
- (3) Position left side (60%) seatback in vehicle.
- (4) Install seatback onto center pivot bracket pin. Ensure seat back is properly engaged on the center pivot pin.
- (5) Position left side support brackets with bolt holes aligned and install support bracket bolts. Tighten bolts to 27 N·m (20 ft. lbs.) torque.
- (6) Install lower seat cushion. Refer to installation procedure.

FRONT CARPET/MAT**REMOVAL**

- (1) Remove lower B-pillar trim panels.
- (2) Remove front and rear seats (as applicable).
- (3) As necessary, remove trim panels and moldings.
- (4) Remove floor console.
- (5) Remove all other interfering components.
- (6) Remove carpet and mat from floor panel (Fig. 52).

INSTALLATION

- (1) Reverse removal procedure.

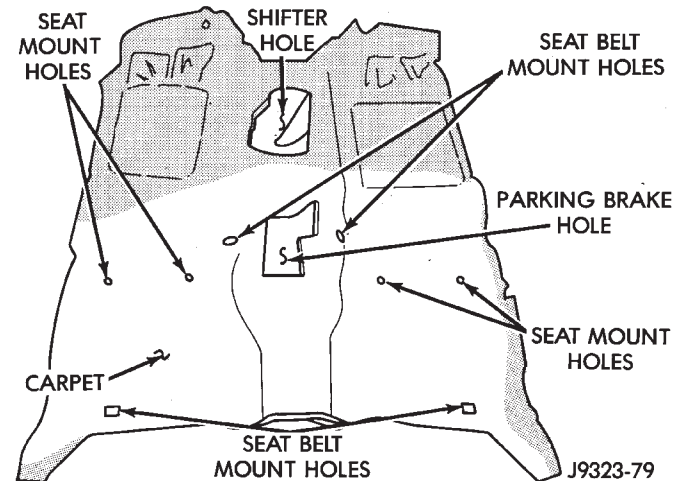


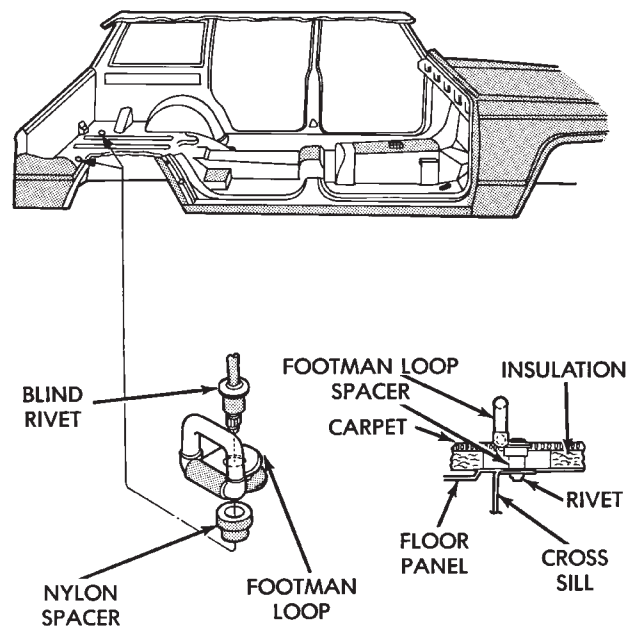
Fig. 52 Front Carpet and Mat

CARGO CARPET/MAT**REMOVAL**

- (1) Remove quarter trim panels.
- (2) Remove liftgate trim panel.
- (3) Drill-out retaining rivet heads and remove cargo tie-down footman loops from carpet (Fig. 53).
- (4) Remove rear seats and belts.
- (5) Remove all other interfering components.
- (6) Remove carpet and mat from floor panel (Fig. 54).
- (7) If necessary, remove skid strips from carpet.

INSTALLATION

- (1) Reverse removal procedure.



J9223-188

Fig. 53 Cargo Tie-Down Footman Loop

REMOVAL AND INSTALLATION (Continued)

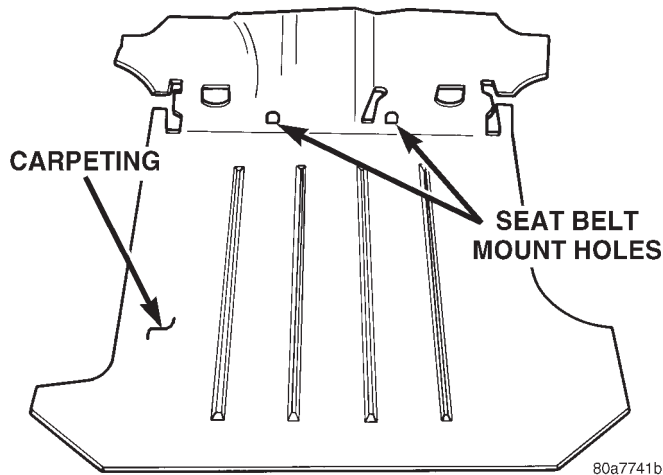


Fig. 54 Cargo Carpet & Mat

REARVIEW MIRROR

REMOVAL

- (1) If equipped, disconnect mirror harness wire connector.
- (2) Loosen the mirror base setscrew (Fig. 55).
- (3) Slide the mirror base upward and off the bracket.

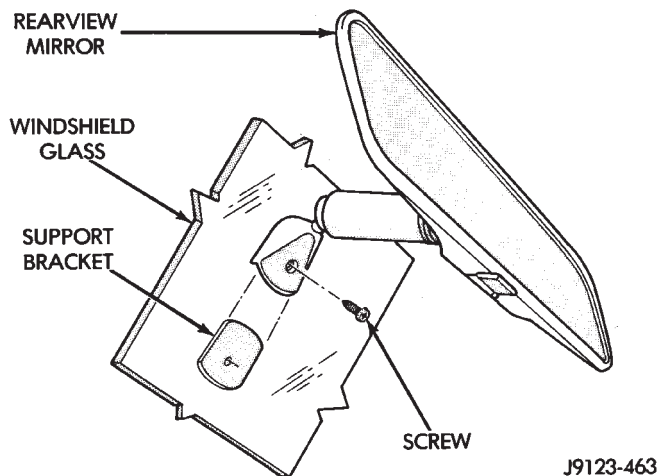


Fig. 55 Rearview Mirror

INSTALLATION

- (1) Position the mirror base at the bracket and slide it downward onto the support bracket.
- (2) Tighten the setscrew 1 N·m (15 in. lbs.) torque.
- (3) If equipped, connect mirror harness wire connector.

REARVIEW MIRROR SUPPORT BRACKET

INSTALLATION

- (1) Mark the position for the mirror bracket on the outside of the windshield glass with a wax pencil.

(2) Clean the bracket contact area on the glass. Use a mild powdered cleanser on a cloth saturated with isopropyl (rubbing) alcohol. Finally, clean the glass with a paper towel dampened with alcohol.

(3) Sand the surface on the support bracket with fine grit-sandpaper. Wipe the bracket surface clean with a paper towel.

(4) Apply accelerator to the surface on the bracket according to the following instructions:

- Crush the vial to saturate the felt applicator.
- Remove the paper sleeve.
- Apply accelerator to the contact surface on the bracket.
- Allow the accelerator to dry for five minutes.
- Do not touch the bracket contact surface after the accelerator has been applied.

(5) Apply adhesive accelerator to the bracket contact surface on the windshield glass. Allow the accelerator to dry for one minute. Do not touch the glass contact surface after the accelerator has been applied.

(6) Install the bracket according to the following instructions:

- Apply one drop of adhesive at the center of the bracket contact-surface on the windshield glass.
- Apply an even coat of adhesive to the contact surface on the bracket.
- Align the bracket with the marked position on the windshield glass.
- Press and hold the bracket in place for at least one minute.

NOTE: Verify that the mirror support bracket is correctly aligned, because the adhesive will cure rapidly.

(7) Allow the adhesive to cure for 8-10 minutes. Remove any excess adhesive with an alcohol-dampened cloth.

(8) Allow the adhesive to cure for an additional 8-10 minutes before installing the mirror.

SUNVISOR

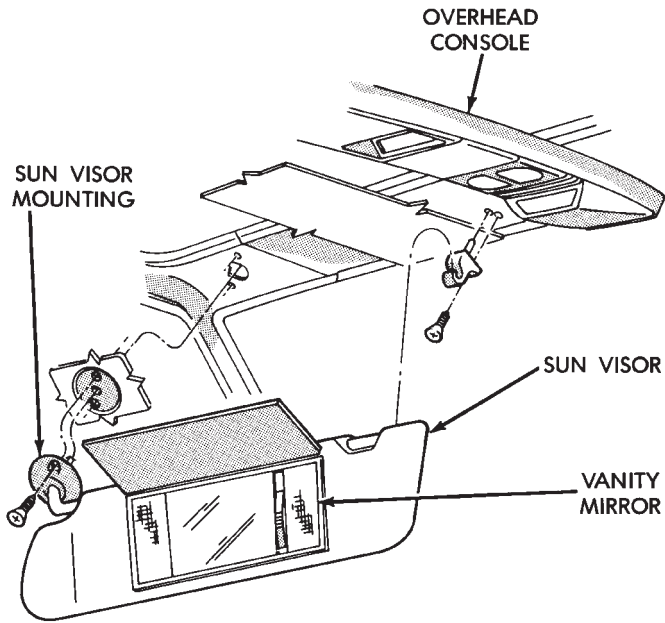
REMOVAL

- (1) Remove screws that attach sunvisor arm support bracket to headliner and roof panel (Fig. 56).
- (2) Detach sunvisor from support bracket.
- (3) Remove sunvisor from vehicle.
- (4) Remove retaining screw and support bracket.

INSTALLATION

- (1) Reverse removal procedure.

REMOVAL AND INSTALLATION (Continued)



J938L-5

Fig. 56 Sunvisor

HEADLINER

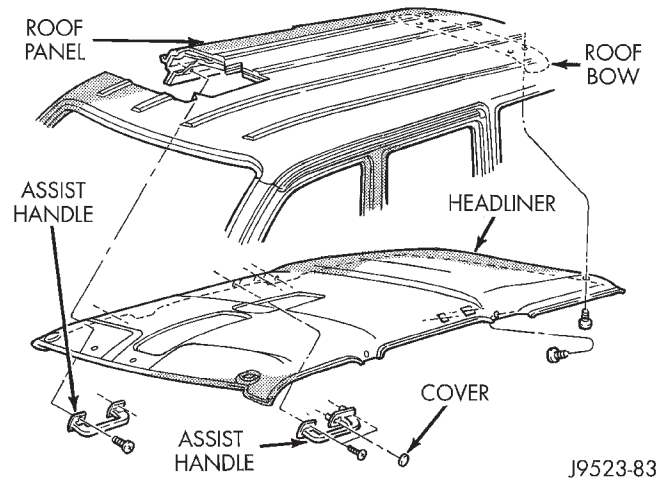
REMOVAL

CAUTION: The headliner is a one-piece, molded component. It has limited flexibility and must not be bent. Damage possibly will result.

- (1) Remove the A, B and C-pillar trim moldings from perimeter of headliner.
- (2) If equipped, remove sound bar. Refer to group 8F, Audio Systems for Service procedures.
- (3) Remove upper liftgate trim molding.
- (4) Remove D-pillar trim molding.
- (5) Remove sunvisors from front of roof panel. Disconnect vanity lamp wiring (if applicable)
- (6) Remove assist handles from side of roof rails.
- (7) Remove push plugs from roof support (Fig. 57).
- (8) Remove dome/reading lamp or overhead console from center of roof panel.
- (9) Remove sunroof pinch welt holding headliner, if equipped (Fig. 58).
- (10) With aid of an assistant, remove headliner through liftgate opening.

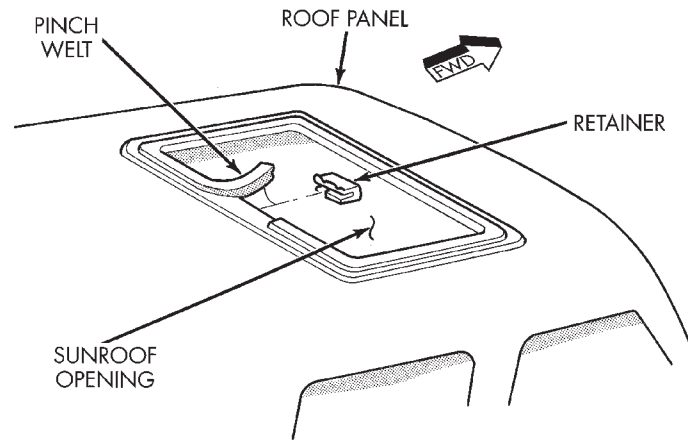
INSTALLATION

- (1) With the aid of an assistant, position headliner in vehicle.
- (2) Install sunroof pinch welt.
- (3) Install dome/reading lamp.
- (4) Install push plugs in roof support.
- (5) Install sunvisors.
- (6) Install assist handles.
- (7) Install A, B, C and D-pillar trim panels.



J9523-83

Fig. 57 Headliner



J9523-84

Fig. 58 Sunroof Opening

- (8) Install liftgate opening upper trim panel.
- (9) If equipped, install sound bar.

LIFTGATE TRIM PANEL

NOTE:

When removing both trim panels from liftgate, remove lower trim panel first. When installing both trim panels, install the upper trim panel first.

UPPER TRIM PANEL REMOVAL

- (1) Remove screws attaching upper trim panel to liftgate (Fig. 59).
- (2) Remove screws at upper and lower trim panel overlap.
- (3) Disengage the connector for the rear window defogger.
- (4) Route the wire harness through the trim panel.
- (5) Gently, pull trim panel downward. If necessary rotate trim panel away from glass panel to release push-in fasteners.

REMOVAL AND INSTALLATION (Continued)

(6) Use a trim panel removal tool to detach push-in fasteners from liftgate.

UPPER TRIM PANEL INSTALLATION

- (1) Position trim panel at liftgate and slide overlapping portions of trim panel under liftgate lower trim panel.
- (2) Route the wire harness through the trim panel.
- (3) Align trim panel push-in fasteners with holes in liftgate inner panel. Press trim panel upward to seat fasteners.
- (4) Engage the connector for the rear window defogger.
- (5) Install screws at upper and lower trim panel overlap.
- (6) Install screws attaching upper trim panel to liftgate.

LOWER TRIM PANEL REMOVAL

- (1) Remove screws attaching lower trim panel to liftgate (Fig. 59).
- (2) Use a trim panel removal tool to detach push-in fasteners from liftgate.

LOWER TRIM PANEL INSTALLATION

- (1) Position trim panel on liftgate.
- (2) Align trim panel push-in fasteners with holes in liftgate inner panel. Press trim panel inward to seat fasteners.
- (3) Install screws attaching lower trim panel to liftgate.

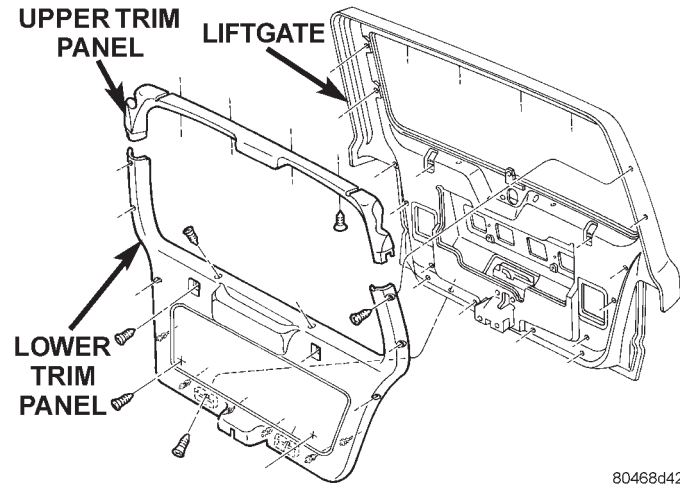


Fig. 59 Liftgate Trim Panel

LIFTGATE

REMOVAL

WARNING: DO NOT DISCONNECT THE SUPPORT ROD CYLINDERS WITH THE LIFTGATE CLOSED. THE SUPPORT ROD PISTONS ARE OPERATED BY HIGH PRESSURE GAS. THIS PRESSURE COULD

CAUSE DAMAGE AND/OR PERSONAL INJURY IF THEY ARE REMOVED WHILE THE PISTONS ARE COMPRESSED.

- (1) Open liftgate. Support liftgate for ease of repair.
- (2) Remove liftgate trim panel.
- (3) Remove retainer clips that secure support rod cylinders to ball studs (Fig. 60).
- (4) Remove support rod cylinders from ball studs.
- (5) Remove upper support rod retaining screws. Remove support rods.
- (6) Disconnect wire harnesses and washer hose from liftgate.
- (7) Remove hinge screws at liftgate (Fig. 61).
- (8) Remove liftgate from vehicle.

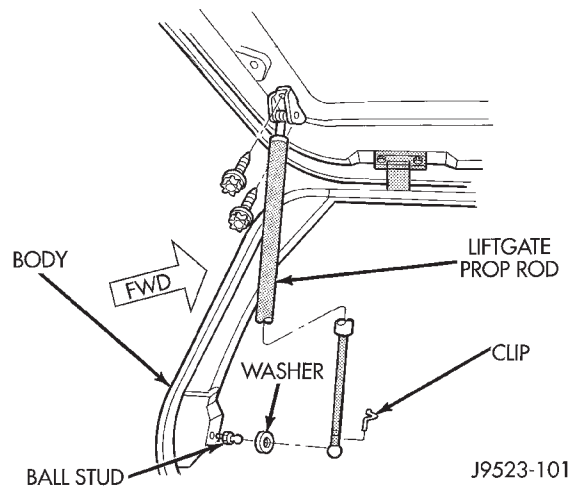


Fig. 60 Liftgate Prop Rod

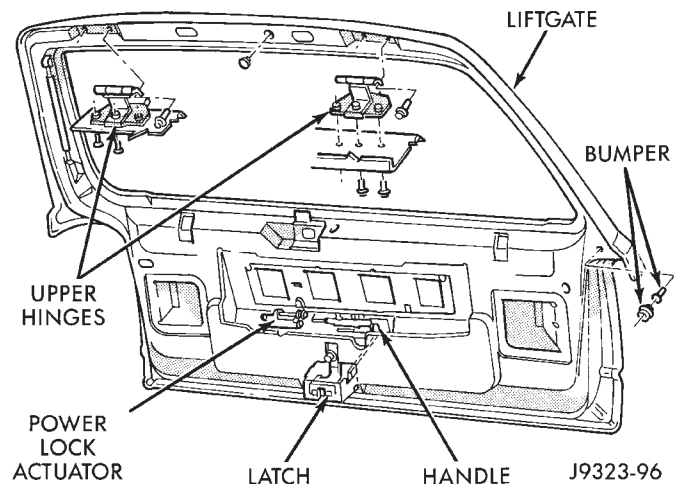


Fig. 61 Liftgate Components

INSTALLATION

- (1) Position liftgate on vehicle. Support liftgate.
- (2) Install hinge screws at liftgate. Tighten hinge screws to 28 N·m (21 ft-lbs) torque

REMOVAL AND INSTALLATION (Continued)

- (3) Connect liftgate wire harnesses and washer hose.
- (4) Install upper support rod retaining screws.
- (5) Install support rod cylinders on ball studs.
- (6) Install liftgate trim panel.

LIFTGATE HINGE

REMOVAL

It is not necessary to remove liftgate to replace one or both hinges. The hinges can be replaced one at a time.

- (1) Remove liftgate opening (headliner) upper trim molding.
- (2) Disconnect wiring harness to cargo lamp.
- (3) Remove hinge screws at roof panel (Fig. 62).
- (4) Remove hinge screws at liftgate.
- (5) Remove hinge from liftgate.

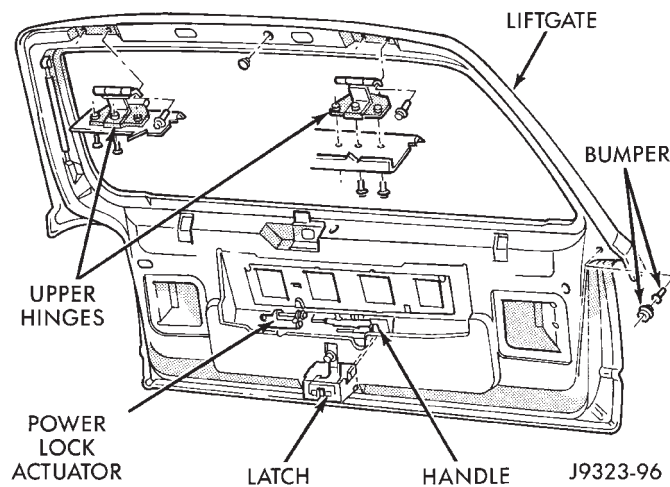


Fig. 62 Liftgate Components

INSTALLATION

- (1) Position hinge on liftgate and roof panel. (Use 3M[®] Fast and Firm or equivalent on the hinge to body mating surface as a sealant).
- (2) Install and tighten hinge screws at roof panel to 28 N·m (21 ft-lbs) torque.
- (3) Install hinge screws at liftgate. Tighten screws to 28 N·m (21 ft-lbs) torque.
- (4) Install liftgate opening (headliner) upper trim molding.

LIFTGATE OUTSIDE HANDLE

REMOVAL

- (1) Remove liftgate lower trim panel.
- (2) Remove liftgate latch and actuator linkages.
- (3) Remove nuts attaching outside handle to liftgate (Fig. 63).
- (4) Separate outside handle from liftgate.

INSTALLATION

- (1) Position outside handle on liftgate.
- (2) Install nuts attaching outside handle to liftgate.
- (3) Install liftgate latch and actuator linkages.
- (4) Install liftgate lower trim panel.

LIFTGATE LOCK CYLINDER

For service, refer to the Liftgate Outside Handle Removal/Installation procedure in this group.

LIFTGATE LATCH

REMOVAL

- (1) Raise liftgate. Remove liftgate lower trim panel. If necessary refer to service procedure.
- (2) Remove latch screws (Fig. 63).
- (3) Disconnect rod from latch.
- (4) Disconnect power lock connector from handle, if equipped (Fig. 64).
- (5) Remove latch from liftgate.

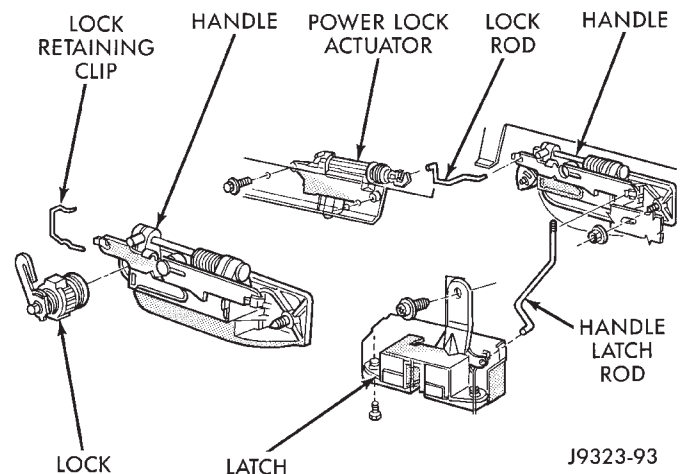


Fig. 63 Liftgate Latch/Lock Component

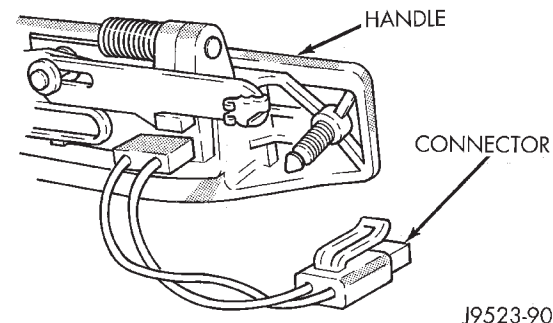


Fig. 64 Power Lock

INSTALLATION

- (1) Reverse removal procedure. Tighten latch screws to 7 N·m (5 ft. lbs.) torque.

REMOVAL AND INSTALLATION (Continued)

LIFTGATE LATCH STRIKER

REMOVAL

- (1) Raise liftgate.
- (2) Remove latch striker nuts from below scuff plate. Access nuts from under bumper fascia/beam (Fig. 65).
- (3) Remove striker, shim and seal plate.

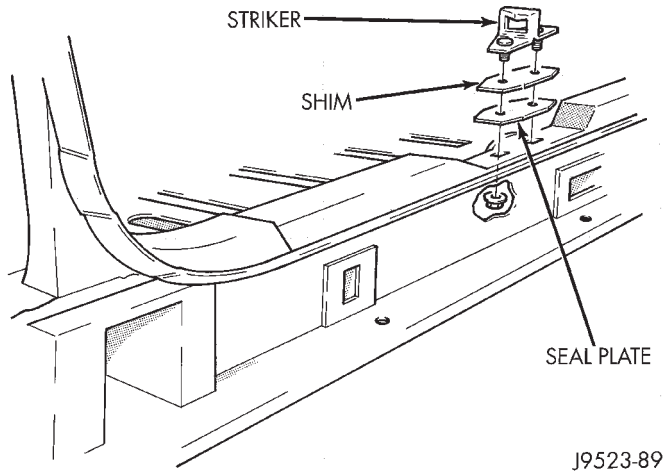


Fig. 65 Liftgate Latch Striker

INSTALLATION

- (1) Position striker, shim and seal plate on vehicle.
- (2) Install latch striker nuts. Tighten striker nuts to 54 N·m (40 ft. lbs.) torque.

LIFTGATE OPENING WEATHERSTRIP

REMOVAL

- (1) Pull seal away from flange around edge of liftgate opening. Remove it from vehicle.
- (2) Clean seal flange as necessary.

INSTALLATION

- (1) Position weatherstrip seal in opening with left end of seal at opening centerline. Install seal in a clockwise direction.
- (2) Seat installed part of seal. Move from left bottom end of seal to top left half of the seal.
- (3) Center and butt seal ends together at centerline.
- (4) If necessary, cut surplus from weatherstrip (non-plug end only).

LIFTGATE FLIP-UP GLASS

REMOVAL

WARNING: DO NOT DISCONNECT THE PROP ROD CYLINDERS WITH THE LIFTGATE FLIP-UP GLASS CLOSED. THE PROP ROD PISTONS ARE OPERATED BY HIGH PRESSURE GAS. THIS PRESSURE COULD CAUSE DAMAGE AND/OR PERSONAL

INJURY IF THEY ARE REMOVED WHILE THE PISTONS ARE COMPRESSED.

- (1) Remove liftgate upper trim panel.
- (2) Open liftgate flip-up glass. Support glass for ease of repair.
- (3) Using a small flat blade or equivalent tool, gently pry open the locking caps on the end of the prop rod.
- (4) Remove prop rod cylinders from ball studs (Fig. 66).
- (5) Remove hinge nuts from liftgate (Fig. 67).
- (6) Separate flip-up glass from vehicle.

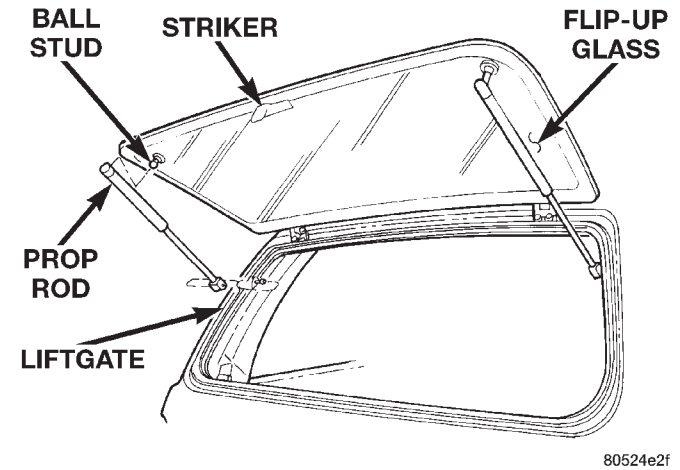


Fig. 66 Prop Rod

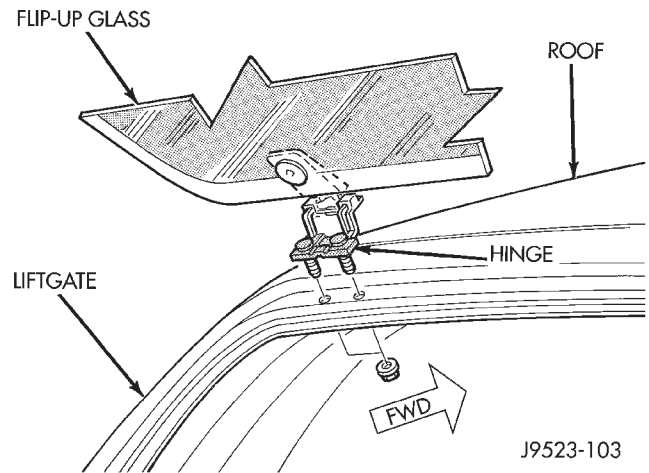


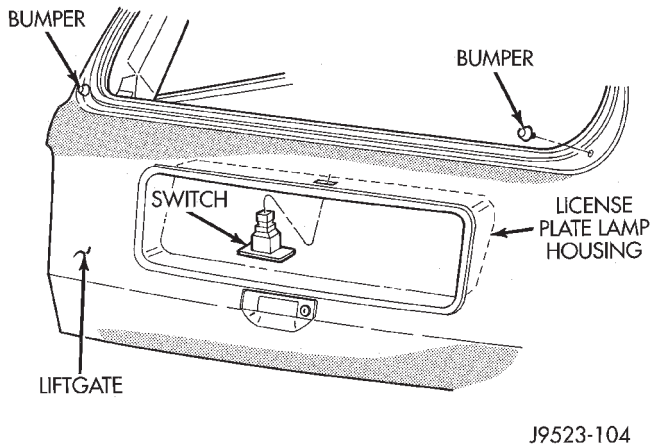
Fig. 67 Hinge Removal

INSTALLATION

- (1) Position flip-up glass on liftgate.
- (2) Install hinge nuts. Hand tighten only.
- (3) With the glass panel in the open and fully raised position, push glass forward to completely seat the hinges. Tighten hinge nuts to 6 N·m (60 in. lbs.).
- (4) Install prop rods onto ball studs and compress locking caps to lock prop rods onto ball studs.

REMOVAL AND INSTALLATION (Continued)**FLIP-UP GLASS SWITCH****REMOVAL**

- (1) Remove liftgate trim panel.
- (2) Remove license plate lamp housing nuts from liftgate.
- (3) Squeeze switch locking tabs inward to release switch from license plate lamp housing.
- (4) Disconnect switch harness connector.
- (5) Separate switch from housing (Fig. 68).

**Fig. 68 Switch Removal****INSTALLATION**

- (1) Position switch into license plate lamp housing and connect switch harness connector.
- (2) Snap switch into place.
- (3) Install license plate lamp housing.
- (4) Install liftgate trim panel.

LIFTGATE FLIP-UP GLASS WEATHERSTRIP**REMOVAL**

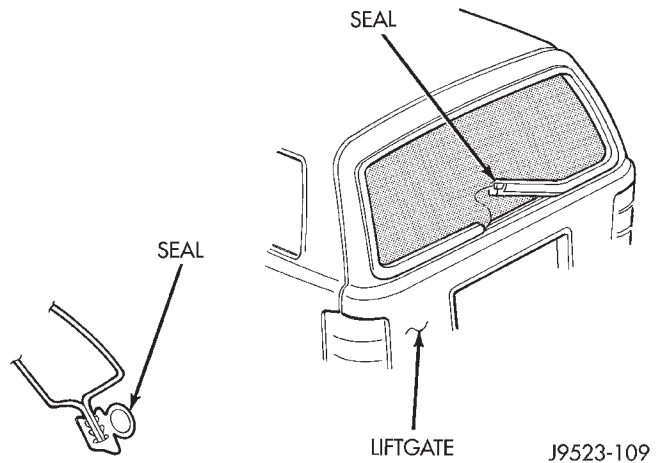
- (1) Slowly pull seal away from flange around edge of glass opening. Remove it from vehicle.
- (2) Clean seal flange as necessary.

INSTALLATION

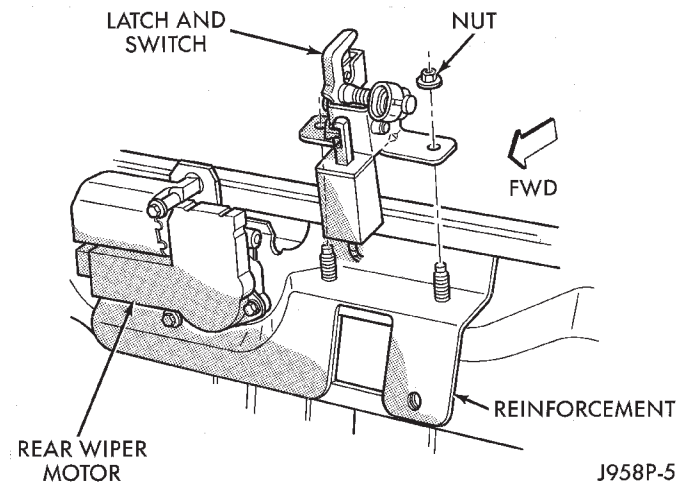
- (1) Position weatherstrip seal with paint dots aligned with window opening corners.
- (2) Seat seal firmly around entire liftgate (Fig. 69).
- (3) Butt seal ends together and smooth out any remaining length. Weatherstrip break should be 120 mm left of latch opening.
- (4) If necessary, cut surplus from weatherstrip (non-plug end only).

LIFTGATE FLIP-UP GLASS LATCH**REMOVAL**

- (1) Raise liftgate.
- (2) Remove liftgate lower trim panel.

**Fig. 69 Liftgate Seal**

- (3) Remove latch nuts (Fig. 70).
- (4) Disconnect switch connectors.
- (5) Remove latch from liftgate.

**Fig. 70 Flip-Up Glass Latch****INSTALLATION**

- (1) Position latch on vehicle, 2.5 mm forward of seal.
- (2) Connect switch connectors.
- (3) Install latch nuts. Tighten to 11 N·m (100 in. lbs.).
- (4) Close flip-up glass panel and verify proper operation.
- (5) Install liftgate lower trim panel.

LIFTGATE FLIP-UP GLASS LATCH HANDLE/STRIKER**REMOVAL**

- (1) Raise flip-up glass.
- (2) Using a wax pencil or equivalent, make alignment marks on the inside and outside of the glass panel.

REMOVAL AND INSTALLATION (Continued)

- (3) Remove handle/striker.

INSTALLATION

- (1) Position handle/striker on glass panel and align reference marks.
- (2) Install handle/striker. Tighten screws to 6 N·m (60 in. lbs.).

LICENSE PLATE LAMP HOUSING

REMOVAL

- (1) Remove liftgate trim panel
- (2) Remove lamp housing retaining screws from liftgate (Fig. 71).
- (3) Disconnect bulb socket from lamp housing.
- (4) Disconnect Flip-Up glass switch connector, if equipped.
- (5) Remove housing from liftgate.

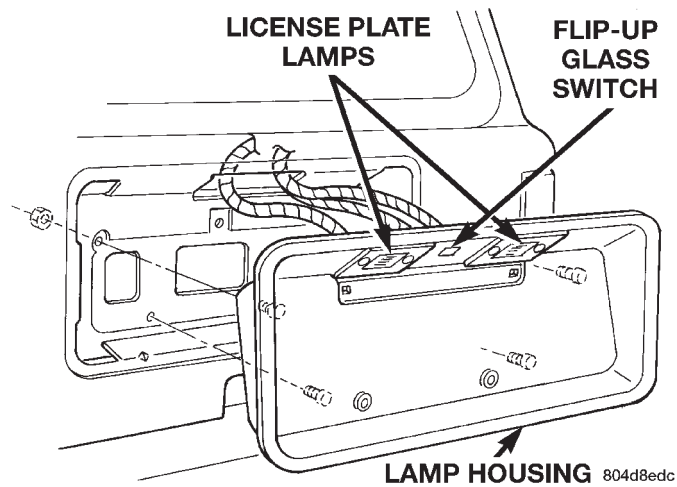


Fig. 71 License Plate Lamp Housing

INSTALLATION

- (1) Position lamp housing at liftgate.
- (2) Connect bulb socket to lamp housing.
- (3) Connect Flip-Up glass switch connector, if equipped.
- (4) Install lamp housing retaining screws in liftgate. Tighten screws securely.
- (5) Install liftgate trim panel.

QUARTER WINDOW APPLIQUE/AIR EXHAUSTER

REMOVAL

- (1) Using a trim stick, carefully pry applique from panel (Fig. 72).
- (2) Carefully pry air exhauster from upper quarter panel using a flat blade screwdriver.

INSTALLATION

- (1) Reseal air exhauster using foam tape.
- (2) Install air exhauster on panel.

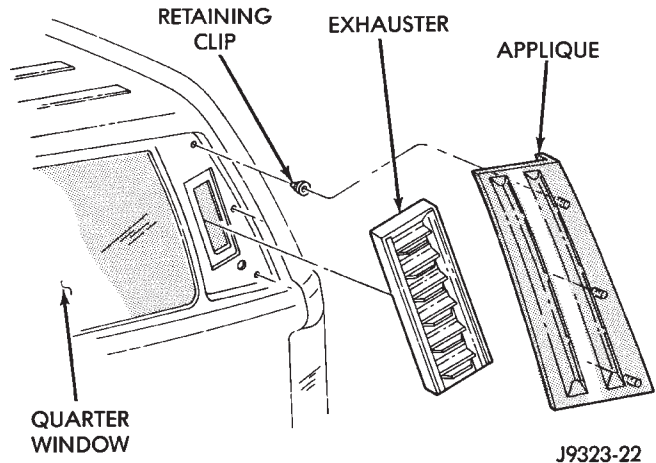


Fig. 72 Quarter Window Applique & Air Exhauster

- (3) Position applique on panel with retainers aligned. Press applique firmly in place.

LUGGAGE RACK

REMOVAL

- (1) Remove slide rail screws (Fig. 73).
- (2) Remove luggage rack from vehicle roof.

NOTE: The skid strips are attached to roof panel with adhesive.

- (3) Loosen each skid strip with a heat gun.
- (4) Lift one edge of each skid strip with a putty knife and peel it from roof panel. Apply additional heat to any location where a skid strip remains.
- (5) Remove original adhesive from roof panel with an all-purpose adhesive removal solution.

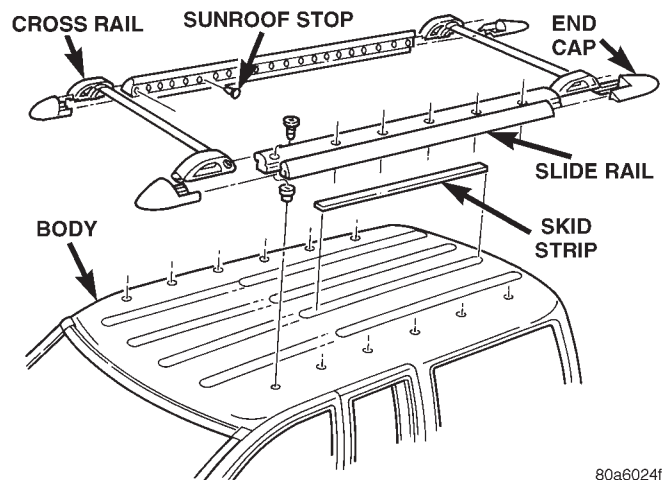


Fig. 73 Luggage Rack

INSTALLATION

- (1) Install 3M 06379 double-sided tape on skid strips.
- (2) Align each skid strip on roof panel.

REMOVAL AND INSTALLATION (Continued)

- (3) Verify that each skid strip is properly aligned.
- (4) Press each skid strip onto roof panel with a roller.

NOTE: Apply 3M Drip-Chek Sealant (or an equivalent product) to underside of side rail screw heads.

- (5) Position luggage rack on roof.
- (6) Install and tighten slide rail screws to 3 N·m (28 in·lbs) torque.

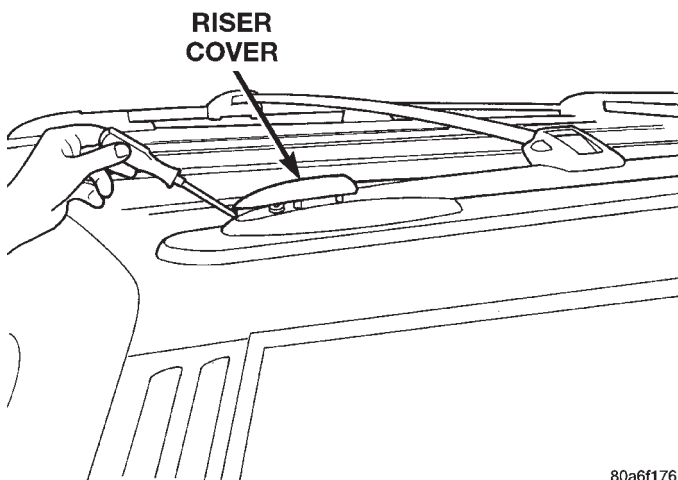
LUGGAGE RACK—LIMITED PLUS

REMOVAL

- (1) Using a small flat blade, carefully pry off riser cover (Fig. 74).
- (2) If necessary, depress the lock buttons on the crossbars and slide crossbars inward to expose the screws attaching the side rails to the risers and adapter plates (Fig. 75).
- (3) Remove the screws attaching the side rails to the risers and adapter plates (Fig. 76).
- (4) Separate the luggage rack from the adapter plates.
- (5) Remove the screws attaching the adapter plates to the roof panel.

NOTE: If a crossbar needs to be removed, the forward or rearward risers have to be removed depending on which crossbar is to be serviced.

- (6) Separate the adapter plates from the roof panel.

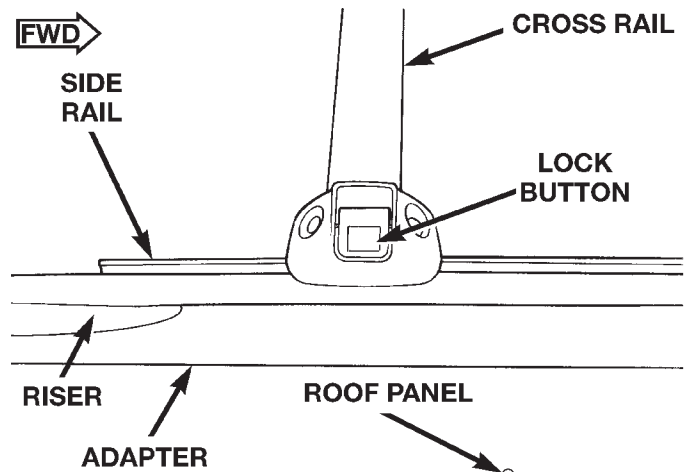


80a6f176

Fig. 74 Riser Cover

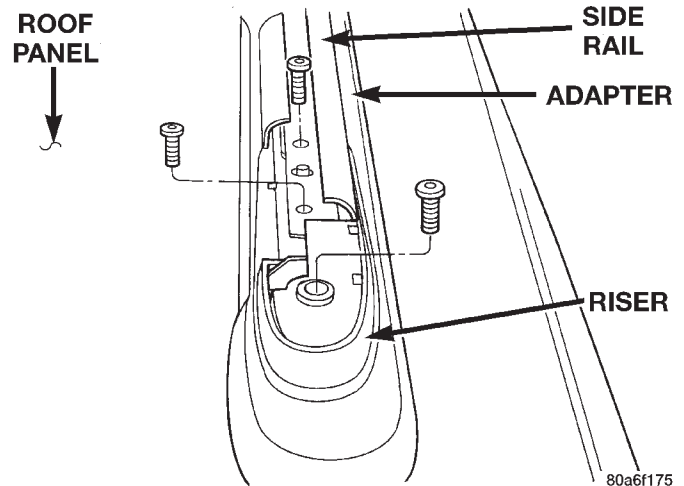
INSTALLATION

- (1) Position the adapter plates on the roof panel and install the screws. Ensure that the gasket is properly seated on the adapter plates.
- (2) Position the luggage rack on the adapter plates.



80a6f174

Fig. 75 Crossbar Lock Button



80a6f175

Fig. 76 Siderail

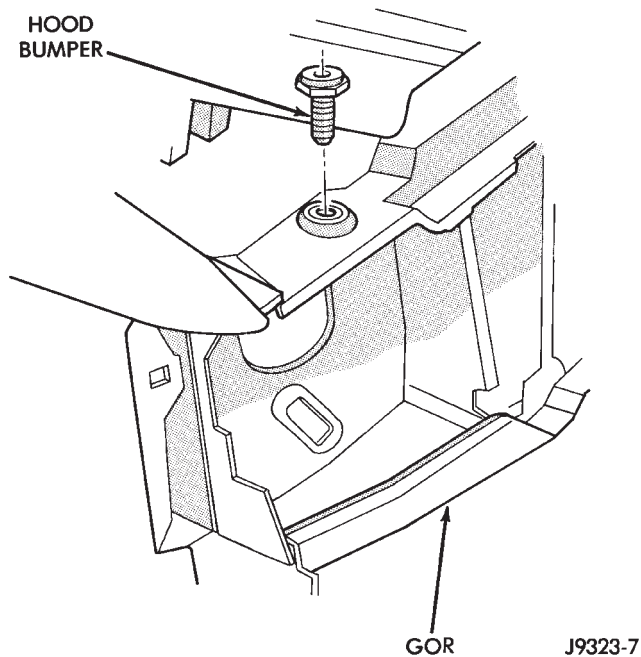
- (3) Install the screws attaching the side rails to the risers and adapter plates.
- (4) Position the riser covers on the risers and press into place.

ADJUSTMENTS

HOOD ADJUSTMENT

The hood attaching holes are enlarged to aid front, back and side-to-side adjustment.

- (1) If hood is low in relation to cowl panel, insert shims between hinge and hood.
- (2) Adjust hood bumper (Fig. 77) in or out to adjust hood-to-fender height alignment.
- (3) Adjust the hood latch as necessary. Tighten the nuts to 11 N·m (8 ft·lbs) torque after adjustment.
- (4) Align latch striker so that striker enters the latch squarely and without binding.

ADJUSTMENTS (Continued)**Fig. 77 Hood Bumper****DOOR**

Minor adjustment for alignment of the door is made by moving the latch striker.

IN AND OUT

- (1) Loosen the latch striker.
- (2) Tap the latch striker inward if the door character line is outboard of the body character line or tap the latch striker outward if the door character line is inboard of the body character line.
- (3) Inspect alignment. If correct, tighten striker with 28 N·m (21 ft. lbs.) torque.

UP AND DOWN

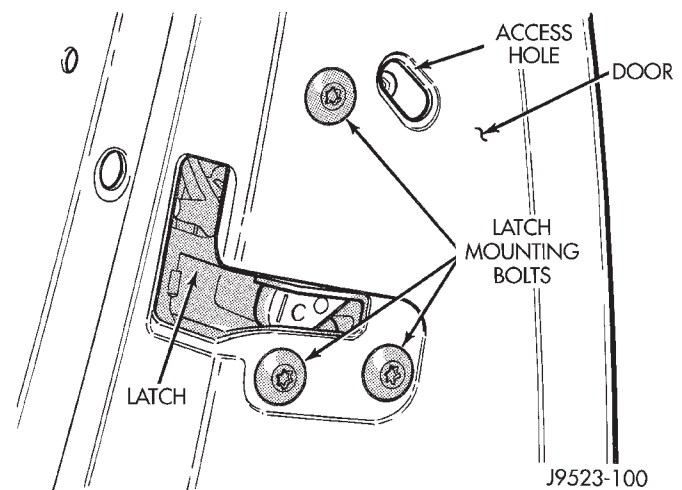
- (1) Loosen the latch striker.
- (2) Tap the latch striker downward if the door character line is higher than the body character line

or tap the latch striker upward if the door character line is lower than the body character line.

- (3) Inspect alignment. If correct, tighten striker with 28 N·m (21 ft. lbs.) torque.

DOOR LATCH ADJUSTMENT

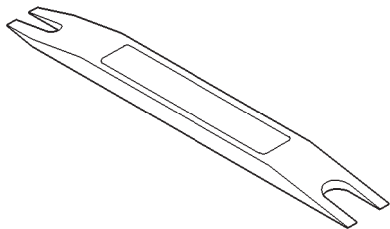
- (1) Locate access hole (Fig. 78).
- (2) Insert a 5/32-inch hex-wrench through hole and into adjustment screw. Loosen screw.
- (3) Operate outside handle button several times to release any restriction because of mis-alignment.
- (4) Tighten adjustment screw to 3 N·m (30 in-lbs) torque.
- (5) Test handle button and lock cylinder for proper operation.

**Fig. 78 Door Latch Adjustment****LIFTGATE**

The position of liftgate can be adjusted upward or downward by use of slots in the hinge. An inward or outward adjustment is achieved by use of slots in the body. If an inward or outward adjustment is needed, use 3MTM Fast and Firm or equivalent on the hinge to body mating surface as a sealant.

SPECIFICATIONS**BODY LUBRICANTS**

COMPONENT	SERVICE INTERVAL	LUBRICANT
Door Hinges	As Required	Multi-Purpose Grease NLGI GC-LB (Water Resistant) (1)
Door Latches	As Required	Multi-Purpose Grease NLGI GC-LB (Water Resistant) (1)
Hood Latch, Release Mechanism and Safety Latch	As Required (When Performing Other Underhood Service)	Multi-Purpose Grease NLGI GC-LB 2 EP (2)
Hood Hinges	As Required	Engine Oil
Seat Track and Release Mechanism	As Required	Multi-Purpose Grease NLGI GC-LB 2 EP (2)
Liftgate Hinge	As Required	Multi-Purpose Grease NLGI GC-LB 2 EP (2)
Liftgate Support Arms	As Required	Engine Oil
Liftgate Latches	As Required	White Spray Lubricant (3)
Liftgate Release Handle (Pivot and Slide Contact Surfaces)	As Required	Multi-Purpose Grease NLGI GC-LB 2 EP (2)
Window System Components	As Required	White Spray Lubricant (3)
Lock Cylinders	Twice a Year	Lock-Cylinder Lubricant (4)
Parking Brake Mechanism	As Required	Multi-Purpose Grease NLGI GC-LB 2 EP (1)
1 = Mopar Wheel Bearing Grease (High Temp) 2 = Mopar Multi-Mileage Lubricant 3 = Mopar Spray White Lube 4 = Mopar Lock Cylinder Lubricant		

SPECIAL TOOLS**BODY**

Remover, Moldings C-4829

HEATING AND AIR CONDITIONING

CONTENTS

	page		page
GENERAL INFORMATION			
HEATER AND AIR CONDITIONER CONTROL . . .	2	COMPRESSOR CLUTCH RELAY	27
HEATER AND AIR CONDITIONER	2	COMPRESSOR	26
SERVICE WARNINGS AND PRECAUTIONS	3	HEATER PERFORMANCE	14
DESCRIPTION AND OPERATION			
ACCUMULATOR	5	HIGH PRESSURE CUT-OFF SWITCH	28
AMBIENT TEMPERATURE SENSOR	5	LOW PRESSURE CYCLING CLUTCH SWITCH .	28
BLOWER MOTOR POWER MODULE	6	REFRIGERANT SYSTEM LEAKS	28
BLOWER MOTOR RESISTOR	6	VACUUM SYSTEM	15
BLOWER MOTOR SWITCH	6	SERVICE PROCEDURES	
BLOWER MOTOR	5	REFRIGERANT OIL LEVEL	30
COMPRESSOR CLUTCH RELAY	7	REFRIGERANT RECOVERY	29
COMPRESSOR CLUTCH	7	REFRIGERANT SYSTEM CHARGE	29
COMPRESSOR	6	REFRIGERANT SYSTEM EVACUATE	29
CONDENSER	7	REMOVAL AND INSTALLATION	
EVAPORATOR COIL	7	ACCUMULATOR	39
FIXED ORIFICE TUBE	8	AMBIENT TEMPERATURE SENSOR	32
HEATER CORE	8	BLOWER MOTOR RESISTOR AND POWER	
HIGH PRESSURE CUT-OFF SWITCH	8	MODULE	45
HIGH PRESSURE RELIEF VALVE	8	BLOWER MOTOR	44
IN-VEHICLE TEMPERATURE SENSOR	9	COMPRESSOR CLUTCH RELAY	38
LOW PRESSURE CYCLING CLUTCH SWITCH . .	9	COMPRESSOR CLUTCH	36
REFRIGERANT LINE COUPLER	10	COMPRESSOR	34
REFRIGERANT LINE	9	CONDENSER	40
REFRIGERANT OIL	10	DISCHARGE LINE	33
REFRIGERANT SYSTEM SERVICE		DOOR ACTUATOR	46
EQUIPMENT	10	DUCTS AND OUTLETS	52
REFRIGERANT SYSTEM SERVICE PORT	11	EVAPORATOR COIL	52
REFRIGERANT	9	FIXED ORIFICE TUBE	38
SOLAR SENSOR	11	HEATER CORE	50
VACUUM CHECK VALVE	11	HEATER-A/C CONTROL	42
VACUUM RESERVOIR	11	HEATER-A/C HOUSING DOOR	50
DIAGNOSIS AND TESTING			
A/C PERFORMANCE	11	HEATER-A/C HOUSING	48
AUTOMATIC TEMPERATURE CONTROL		HIGH PRESSURE CUT-OFF SWITCH	33
SYSTEM	17	HIGH PRESSURE RELIEF VALVE	35
BLOWER MOTOR RESISTOR	26	IN-VEHICLE TEMPERATURE SENSOR	44
BLOWER MOTOR SWITCH	26	LIQUID LINE	38
BLOWER MOTOR	25	LOW PRESSURE CYCLING CLUTCH SWITCH .	39
COMPRESSOR CLUTCH COIL	27	REFRIGERANT LINE COUPLER	32
		SOLAR SENSOR	43
		VACUUM CHECK VALVE	42
		VACUUM RESERVOIR	42

GENERAL INFORMATION

HEATER AND AIR CONDITIONER

A manual temperature control type heating-air conditioning system is standard factory-installed equipment on this model. An electronically controlled Automatic Temperature Control (ATC) type heating-air conditioning system is an available factory-installed option.

All vehicles are equipped with a common heater-A/C housing assembly (Fig. 1). The system combines air conditioning, heating, and ventilating capabilities in a single unit housing mounted under the instrument panel.

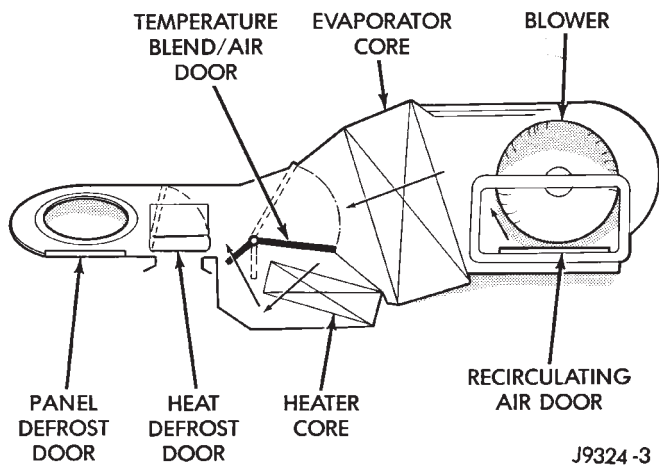


Fig. 1 Common Blend-Air Heater-Air Conditioner System

Outside fresh air enters the vehicle through the cowl top opening at the base of the windshield, and passes through a plenum chamber to the heater-A/C system blower housing. Air flow velocity can then be adjusted with the blower motor speed selector switch on the heater-A/C control panel. The air intake openings must be kept free of snow, ice, leaves, and other obstructions for the heater-A/C system to receive a sufficient volume of outside air.

It is also important to keep the air intake openings clear of debris because leaf particles and other debris that is small enough to pass through the cowl plenum screen can accumulate within the heater-A/C housing. The closed, warm, damp and dark environment created within the heater-A/C housing is ideal for the growth of certain molds, mildews and other fungi. Any accumulation of decaying plant matter provides an additional food source for fungal spores, which enter the housing with the fresh air. Excess debris, as well as objectionable odors created by decaying plant matter and growing fungi can be discharged into the passenger compartment during heater-A/C system operation.

Both the manual and ATC heater and air conditioner are blend-air type systems. In a blend-air system, a blend-air door controls the amount of unconditioned air (or cooled air from the evaporator) that is allowed to flow through, or around, the heater core. A temperature control knob on the heater-A/C control panel determines the discharge air temperature by energizing the blend-air door motor, which operates the blend-air door. This allows an almost immediate control of the output air temperature of the system.

The mode control knob on the heater-A/C control panel is used to direct the conditioned air to the selected system outlets. On manual temperature control systems, the mode control knob switches engine vacuum to control the mode doors, which are operated by vacuum actuator motors. On ATC systems, the mode control knob switches electrical current to control the mode doors, which are operated by electronic actuator motors.

The outside air intake can be shut off by selecting the Recirculation Mode with the mode control knob. This will operate the recirculating air door that closes off the outside fresh air intake and recirculates the air that is already inside the vehicle.

The air conditioner for all models is designed for the use of non-CFC, R-134a refrigerant. The air conditioning system has an evaporator to cool and dehumidify the incoming air prior to blending it with the heated air. This air conditioning system uses a fixed orifice tube in the liquid line near the condenser outlet tube to meter refrigerant flow to the evaporator coil. To maintain minimum evaporator temperature and prevent evaporator freezing, a fixed pressure setting switch on the accumulator cycles the compressor clutch.

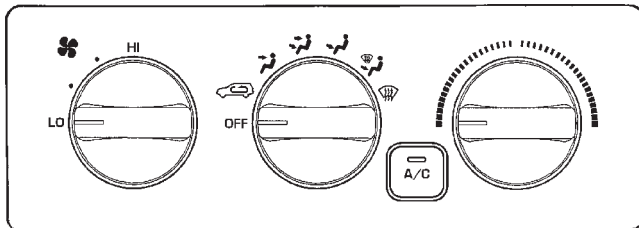
HEATER AND AIR CONDITIONER CONTROL

The manual temperature control heater-A/C system uses a combination of electrical, and vacuum controls. The Automatic Temperature Control (ATC) heater-A/C system uses only electrical controls. These controls provide the vehicle operator with a number of setting options to help control the climate and comfort within the vehicle. Refer to the owner's manual in the vehicle glove box for more information on the suggested operation and use of these controls.

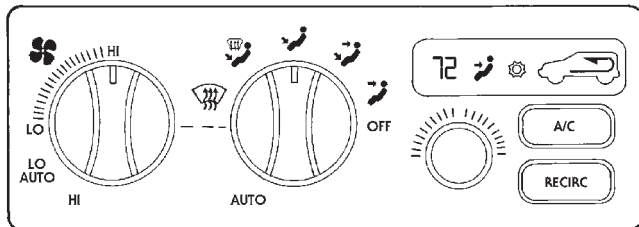
Both heater-A/C control panels are located on the instrument panel inboard of the steering column and below the radio (Fig. 2). Both control panels contain a rotary-type temperature control knob, a rotary-type mode control switch knob, a rotary-type blower motor speed switch knob and an air conditioning compressor push button switch. The ATC control panel also features a Recirc push button switch and a vacuum fluorescent display area.

GENERAL INFORMATION (Continued)

MANUAL AIR CONDITIONING SYSTEM



AUTOMATIC TEMPERATURE CONTROL SYSTEM



80a8ea24

Fig. 2 Heater-Air Conditioner Control Panels

The ATC control panel includes the ATC control module. The ATC control module contains a micro-processor and uses internal programming along with hard-wired sensor inputs and messages received on the Chrysler Collision Detection (CCD) data bus network to control the many functions and features of the ATC system.

Both the manual heater-A/C control panel and the ATC control panel are serviced only as complete units and cannot be repaired. If faulty or damaged, the entire control panel unit must be replaced.

SERVICE WARNINGS AND PRECAUTIONS

WARNING:

- THE AIR CONDITIONING SYSTEM CONTAINS REFRIGERANT UNDER HIGH PRESSURE. SEVERE PERSONAL INJURY MAY RESULT FROM IMPROPER SERVICE PROCEDURES. REPAIRS SHOULD ONLY BE PERFORMED BY QUALIFIED SERVICE PERSONNEL.

- AVOID BREATHING THE REFRIGERANT AND REFRIGERANT OIL VAPOR OR MIST. EXPOSURE MAY IRRITATE THE EYES, NOSE, AND/OR THROAT. WEAR EYE PROTECTION WHEN SERVICING THE AIR CONDITIONING REFRIGERANT SYSTEM. SERIOUS EYE INJURY CAN RESULT FROM DIRECT CONTACT WITH THE REFRIGERANT. IF EYE CONTACT OCCURS, SEEK MEDICAL ATTENTION IMMEDIATELY.

- DO NOT EXPOSE THE REFRIGERANT TO OPEN FLAME. POISONOUS GAS IS CREATED WHEN REFRIGERANT IS BURNED. AN ELECTRONIC LEAK DETECTOR IS RECOMMENDED.

- IF ACCIDENTAL SYSTEM DISCHARGE OCCURS, VENTILATE THE WORK AREA BEFORE RESUMING SERVICE. LARGE AMOUNTS OF REFRIGERANT RELEASED IN A CLOSED WORK AREA WILL DISPLACE THE OXYGEN AND CAUSE SUFFOCATION.

- THE EVAPORATION RATE OF R-134a REFRIGERANT AT AVERAGE TEMPERATURE AND ALTITUDE IS EXTREMELY HIGH. AS A RESULT, ANYTHING THAT COMES IN CONTACT WITH THE REFRIGERANT WILL FREEZE. ALWAYS PROTECT THE SKIN OR DELICATE OBJECTS FROM DIRECT CONTACT WITH THE REFRIGERANT.

- THE R-134a SERVICE EQUIPMENT OR THE VEHICLE REFRIGERANT SYSTEM SHOULD NOT BE PRESSURE TESTED OR LEAK TESTED WITH COMPRESSED AIR. SOME MIXTURES OF AIR AND R-134a HAVE BEEN SHOWN TO BE COMBUSTIBLE AT ELEVATED PRESSURES. THESE MIXTURES ARE POTENTIALLY DANGEROUS, AND MAY RESULT IN FIRE OR EXPLOSION CAUSING INJURY OR PROPERTY DAMAGE.

GENERAL INFORMATION (Continued)**CAUTION:**

- Liquid refrigerant is corrosive to metal surfaces. Follow the operating instructions supplied with the service equipment being used.
- Never add R-12 to a refrigerant system designed to use R-134a. Damage to the system will result.
- R-12 refrigerant oil must not be mixed with R-134a refrigerant oil. They are not compatible.
- Do not use R-12 equipment or parts on the R-134a system. Damage to the system will result.
- Do not overcharge the refrigerant system. This will cause excessive compressor head pressure and can cause noise and system failure.
- Recover the refrigerant before opening any fitting or connection. Open the fittings with caution, even after the system has been discharged. Never open or loosen a connection before recovering the refrigerant.
- The refrigerant system must always be evacuated before charging.
- Do not open the refrigerant system or uncap a replacement component until you are ready to service the system. This will prevent contamination in the system.
- Before disconnecting a component, clean the outside of the fittings thoroughly to prevent contamination from entering the refrigerant system.
- Immediately after disconnecting a component from the refrigerant system, seal the open fittings with a cap or plug.
- Before connecting an open refrigerant fitting, always install a new seal or gasket. Coat the fitting and seal with clean refrigerant oil before connecting.
- Do not remove the sealing caps from a replacement component until it is to be installed.
- When installing a refrigerant line, avoid sharp bends that may restrict refrigerant flow. Position the refrigerant lines away from exhaust system components or any sharp edges, which may damage the line.
- Tighten refrigerant fittings only to the specified torque. The aluminum fittings used in the refrigerant system will not tolerate overtightening.
- When disconnecting a refrigerant fitting, use a wrench on both halves of the fitting. This will prevent twisting of the refrigerant lines or tubes.
- Refrigerant oil will absorb moisture from the atmosphere if left uncapped. Do not open a container of refrigerant oil until you are ready to use it. Replace the cap on the oil container immediately after using. Store refrigerant oil only in a clean, airtight, and moisture-free container.

- Keep service tools and the work area clean. Contamination of the refrigerant system through careless work habits must be avoided.

COOLING SYSTEM REQUIREMENTS

To maintain the performance level of the heating-air conditioning system, the engine cooling system must be properly maintained. The use of a bug screen is not recommended. Any obstructions in front of the radiator or condenser will reduce the performance of the air conditioning and engine cooling systems.

The engine cooling system includes the heater core and the heater hoses. Refer to Group 7 - Cooling System for more information before the opening of, or attempting any service to the engine cooling system.

REFRIGERANT HOSES/LINES/TUBES PRECAUTIONS

Kinks or sharp bends in the refrigerant plumbing will reduce the capacity of the entire system. High pressures are produced in the system when it is operating. Extreme care must be exercised to make sure that all refrigerant system connections are pressure tight.

A good rule for the flexible hose refrigerant lines is to keep the radius of all bends at least ten times the diameter of the hose. Sharp bends will reduce the flow of refrigerant. The flexible hose lines should be routed so they are at least 80 millimeters (3 inches) from the exhaust manifold. It is a good practice to inspect all flexible refrigerant system hose lines at least once a year to make sure they are in good condition and properly routed.

There are two types of refrigerant fittings:

- All fittings with O-rings need to be coated with refrigerant oil before installation. Use only O-rings approved for use with R-134a refrigerant. Failure to do so may result in a leak.
- Unified plumbing connections with aluminum gaskets cannot be serviced with O-rings. The gaskets are not reusable and new gaskets do not require lubrication before installing.

Using the proper tools when making a refrigerant plumbing connection is very important. Improper tools or improper use of the tools can damage the refrigerant fittings. Always use two wrenches when loosening or tightening tube fittings. Use one wrench to hold one side of the connection stationary, while loosening or tightening the other side of the connection with a second wrench.

The refrigerant must be recovered completely from the system before opening any fitting or connection. Open the fittings with caution, even after the refrigerant has been recovered. If any pressure is noticed

GENERAL INFORMATION (Continued)

as a fitting is loosened, tighten the fitting and recover the refrigerant from the system again.

Do not discharge refrigerant into the atmosphere. Use an R-134a refrigerant recovery/recycling device that meets SAE Standard J2210.

The refrigerant system will remain chemically stable as long as pure, moisture-free R-134a refrigerant and refrigerant oil is used. Dirt, moisture, or air can upset this chemical stability. Operational troubles or serious damage can occur if foreign material is present in the refrigerant system.

When it is necessary to open the refrigerant system, have everything needed to service the system ready. The refrigerant system should not be left open to the atmosphere any longer than necessary. Cap or plug all lines and fittings as soon as they are opened to prevent the entrance of dirt and moisture. All lines and components in parts stock should be capped or sealed until they are to be installed.

All tools, including the refrigerant recycling equipment, the manifold gauge set, and test hoses should be kept clean and dry. All tools and equipment must be designed for R-134a refrigerant.

DESCRIPTION AND OPERATION

ACCUMULATOR

The accumulator is mounted in the engine compartment between the evaporator coil outlet tube and the compressor inlet. Refrigerant enters the accumulator canister as a low pressure vapor through the inlet tube.

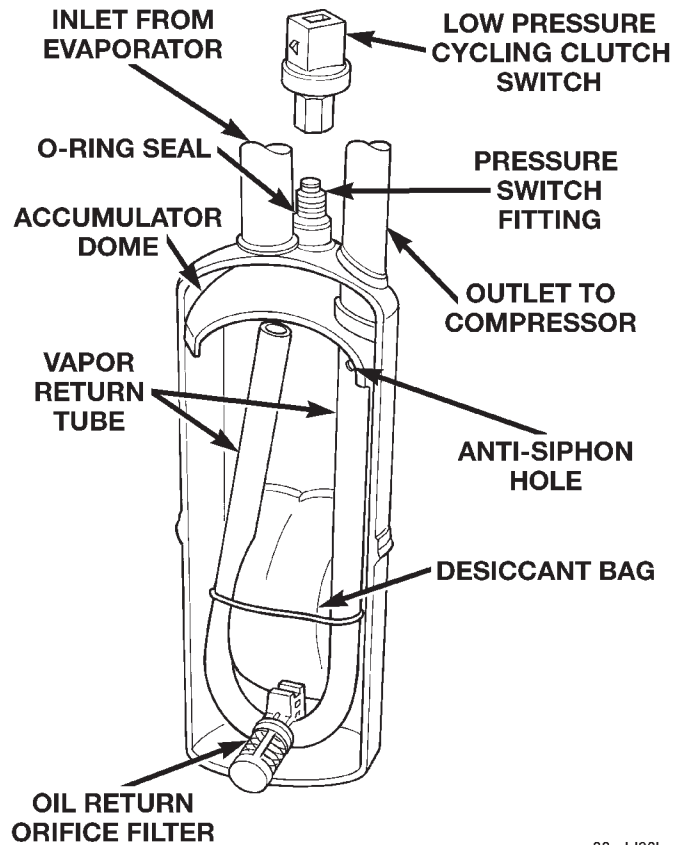
Any liquid, oil-laden refrigerant falls to the bottom of the canister, which acts as a separator. A desiccant bag is mounted inside the accumulator canister to absorb any moisture which may have entered and become trapped within the refrigerant system (Fig. 3).

AMBIENT TEMPERATURE SENSOR

Models with the optional Automatic Temperature Control (ATC) system use an input from the ambient temperature sensor. The sensor is located in front of the condenser and behind the radiator grille on the center radiator support.

The ambient temperature sensor is hard-wired to the Body Control Module (BCM). The BCM places an ambient temperature message on the CCD data bus for use by the overhead console for the thermometer function, and for use by the ATC control module.

The ambient temperature sensor is a Negative Temperature Coefficient (NTC) thermistor or temperature sensitive resistor. The ATC control module uses this sensor input to monitor the outside air temperature. However, because heat from the radiator and condenser can affect the accuracy of the input from



80add30b

Fig. 3 Accumulator - Typical

this sensor when the vehicle is not moving, this input is only used by the ATC system when the vehicle is in motion.

The ambient temperature sensor cannot be adjusted or repaired and, if faulty or damaged, it must be replaced.

BLOWER MOTOR

The blower motor and blower wheel are located in the passenger side end of the heater-A/C housing, below the glove box module. The blower motor controls the velocity of the air flowing through the heater-A/C housing by spinning a squirrel cage-type blower wheel within the housing at the selected speed. The blower motor and blower wheel can be serviced from the passenger compartment side of the housing.

The blower motor will only operate when the ignition switch is in the On position, and the heater-A/C mode control switch knob is in any position, except Off. The blower motor circuit is protected by a fuse in the junction block. On models with the standard manual temperature control system, the blower motor speed is controlled by regulating the battery feed through the blower motor switch and the blower motor resistor. On models with the optional Automatic Temperature Control (ATC) system, the blower

DESCRIPTION AND OPERATION (Continued)

motor speed is controlled by the blower motor power module, which adjusts the battery feed voltage to the blower motor based upon an input from the blower motor switch through the ATC control module.

The blower motor and blower motor wheel cannot be repaired and, if faulty or damaged, they must be replaced. The blower motor and blower wheel are each serviced separately.

BLOWER MOTOR POWER MODULE

Models equipped with the optional Automatic Temperature Control (ATC) system have a blower motor power module. The power module allows the selection of almost infinitely variable blower motor speeds. The power module is mounted to the heater-A/C housing, under the instrument panel and just inboard of the blower motor, in the same location used for the blower motor resistor on manual temperature control systems. It can be accessed without removing any other components.

The blower motor power module output to the blower motor can be controlled by adjusting the blower motor speed switch knob on the ATC heater-A/C control panel, or it can be adjusted automatically by the logic circuitry and programming of the ATC control module. In either case, the ATC control module sends the correct pulse-width modulated signal to the power module to obtain the selected or programmed blower motor speed.

The blower motor power module cannot be repaired and, if faulty or damaged, it must be replaced.

BLOWER MOTOR RESISTOR

Models with the standard manual temperature control system have a blower motor resistor. The blower motor resistor is mounted to the bottom of the heater-A/C housing, under the instrument panel and just inboard of the blower motor. It can be accessed for service without removing any other components.

The resistor has multiple resistor wires, each of which will reduce the current flow to the blower motor to change the blower motor speed by changing the resistance in the blower motor ground path. The blower motor switch directs the ground path through the correct resistor wire to obtain the selected speed.

With the blower motor switch in the lowest speed position, the ground path for the motor is applied through all of the resistor wires. Each higher speed selected with the blower motor switch applies the blower motor ground path through fewer of the resistor wires, increasing the blower motor speed. When the blower motor switch is in the highest speed position, the blower motor resistor is bypassed and the blower motor receives a direct path to ground.

The blower motor resistor cannot be repaired and, if faulty or damaged, it must be replaced.

BLOWER MOTOR SWITCH

The heater-A/C blower motor is controlled by a rotary-type blower motor switch, mounted in the heater-A/C control panel. On vehicles with manual temperature control systems, the switch allows the selection of four blower motor speeds, but will only operate with the ignition switch in the On position and the heater-A/C mode control switch in any position, except Off. On vehicles with the Automatic Temperature Control (ATC) systems, the switch allows the selection of Lo Auto, Hi Auto, and an infinite number of manual speed settings between Lo and Hi.

On manual temperature control systems, the blower motor switch is connected in series with the blower motor ground path through the heater-A/C mode control switch. The blower motor switch directs this ground path to the blower motor through the blower motor resistor wires, or directly to the blower motor, as required to achieve the selected blower motor speed.

On ATC systems, the blower motor switch is just one of many inputs to the ATC control module. In the manual blower modes, the ATC control module adjusts the blower motor speed through the blower motor power module as required to achieve the selected blower switch position. In the auto blower modes, the ATC controller is programmed to select and adjust the blower motor speed through the blower motor power module as required to achieve and maintain the selected comfort level.

The blower motor switch cannot be repaired and, if faulty or damaged, it must be replaced. The switch is serviced only as a part of the heater-A/C control assembly.

COMPRESSOR

The air conditioning system uses a Nippon Denso 10PA17 ten cylinder, double-acting swash plate-type compressor on all models. This compressor has a fixed displacement of 170 cubic centimeters (10.374 cubic inches), and has both the suction and discharge ports located on the cylinder head. A label identifying the use of R-134a refrigerant is located on the compressor.

The compressor is driven by the engine through an electric clutch, drive pulley and belt arrangement. The compressor is lubricated by refrigerant oil that is circulated throughout the refrigerant system with the refrigerant.

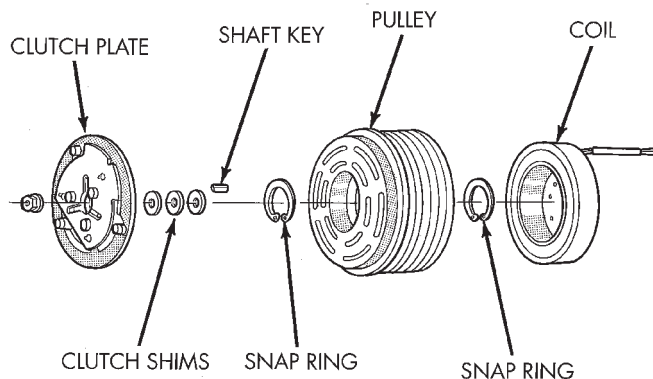
The compressor draws in low-pressure refrigerant vapor from the evaporator through its suction port. It then compresses the refrigerant into a high-pressure, high-temperature refrigerant vapor, which is then pumped to the condenser through the compressor discharge port.

DESCRIPTION AND OPERATION (Continued)

The compressor cannot be repaired. If faulty or damaged, the entire compressor assembly must be replaced. The compressor clutch, pulley and clutch coil are available for service.

COMPRESSOR CLUTCH

The compressor clutch assembly consists of a stationary electromagnetic coil, a hub bearing and pulley assembly, and a clutch plate (Fig. 4). The electromagnetic coil unit and the hub bearing and pulley assembly are each retained on the nose of the compressor front housing with snap rings. The clutch plate is keyed to the compressor shaft and secured with a screw.



J9524-33

Fig. 4 Compressor Clutch - Typical

These components provide the means to engage and disengage the compressor from the engine serpentine accessory drive belt. When the clutch coil is energized, it magnetically draws the clutch into contact with the pulley and drives the compressor shaft. When the coil is not energized, the pulley freewheels on the clutch hub bearing, which is part of the pulley. The compressor clutch and coil are the only serviced parts on the compressor.

The compressor clutch engagement is controlled by several components: the A/C switch on the heater-A/C control panel, the Automatic Temperature Control (ATC) control module (if the vehicle is so equipped), the low pressure cycling clutch switch, the high pressure cut-off switch, the compressor clutch relay, and the Powertrain Control Module (PCM). The PCM may delay compressor clutch engagement for up to thirty seconds. Refer to Group 14 - Fuel System for more information on the PCM controls.

COMPRESSOR CLUTCH RELAY

The compressor clutch relay is a International Standards Organization (ISO) micro-relay. The terminal designations and functions are the same as a conventional ISO relay. However, the micro-relay terminal orientation (footprint) is different, the cur-

rent capacity is lower, and the relay case dimensions are smaller than those of the conventional ISO relay.

The compressor clutch relay is a electromechanical device that switches battery current to the compressor clutch coil when the Powertrain Control Module (PCM) grounds the coil side of the relay. The PCM responds to inputs from the A/C compressor switch on the heater-A/C control panel, the Automatic Temperature Control (ATC) control module (if the vehicle is so equipped), the low pressure cycling clutch switch, and the high pressure cut-off switch. See the Diagnosis and Testing section of this group for more information on the operation of the compressor clutch relay.

The compressor clutch relay is located in the Power Distribution Center (PDC) in the engine compartment. Refer to the PDC label for relay identification and location.

The compressor clutch relay cannot be repaired and, if faulty or damaged, it must be replaced.

CONDENSER

The condenser is located in the air flow in front of the engine cooling radiator. The condenser is a heat exchanger that allows the high-pressure refrigerant gas being discharged by the compressor to give up its heat to the air passing over the condenser fins. When the refrigerant gas gives up its heat, it condenses. When the refrigerant leaves the condenser, it has become a high-pressure liquid refrigerant.

The volume of air flowing over the condenser fins is critical to the proper cooling performance of the air conditioning system. Therefore, it is important that there are no objects placed in front of the radiator grille openings in the front of the vehicle or foreign material on the condenser fins that might obstruct proper air flow. Also, any factory-installed air seals or shrouds must be properly reinstalled following radiator or condenser service.

The condenser cannot be repaired and, if faulty or damaged, it must be replaced.

EVAPORATOR COIL

The evaporator coil is located in the heater-A/C housing, under the instrument panel. The evaporator coil is positioned in the heater-A/C housing so that all air that enters the housing must pass over the fins of the evaporator before it is distributed through the system ducts and outlets. However, air passing over the evaporator coil fins will only be conditioned when the compressor is engaged and circulating refrigerant through the evaporator coil tubes.

Refrigerant enters the evaporator from the fixed orifice tube as a low-temperature, low-pressure liquid. As air flows over the fins of the evaporator, the humidity in the air condenses on the fins, and the

DESCRIPTION AND OPERATION (Continued)

heat from the air is absorbed by the refrigerant. Heat absorption causes the refrigerant to boil and vaporize. The refrigerant becomes a low-pressure gas before it leaves the evaporator.

The evaporator coil cannot be repaired and, if faulty or damaged, it must be replaced.

FIXED ORIFICE TUBE

The fixed orifice tube is installed in the liquid line between the outlet of the condenser and the inlet of the evaporator. The fixed orifice tube is only serviced as an integral part of the liquid line.

The inlet end of the fixed orifice tube has a nylon mesh filter screen, which filters the refrigerant and helps to reduce the potential for blockage of the metering orifice by refrigerant system contaminants (Fig. 5). The outlet end of the tube has a nylon mesh diffuser screen. The O-rings on the plastic body of the fixed orifice tube seal the tube to the inside of the liquid line and prevent the refrigerant from bypassing the fixed metering orifice.

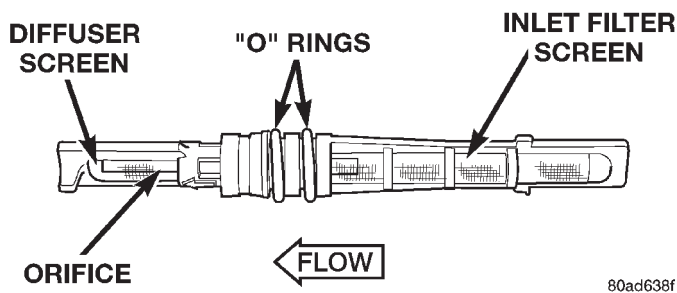


Fig. 5 Fixed Orifice Tube - Typical

The fixed orifice tube is used to meter the flow of liquid refrigerant into the evaporator coil. The high-pressure liquid refrigerant from the condenser expands into a low-pressure liquid as it passes through the metering orifice and diffuser screen of the fixed orifice tube.

The fixed orifice tube cannot be repaired and, if faulty or plugged, the liquid line assembly must be replaced.

HEATER CORE

The heater core is located in the heater-A/C housing, under the instrument panel. It is a heat exchanger made of rows of tubes and fins. Engine coolant is circulated through heater hoses to the heater core at all times. As the coolant flows through the heater core, heat removed from the engine is transferred to the heater core fins and tubes.

Air directed through the heater core picks up the heat from the heater core fins. The blend air door allows control of the heater output air temperature by controlling how much of the air flowing through the heater-A/C housing is directed through the

heater core. The blower motor speed controls the volume of air flowing through the heater-A/C housing.

The heater core cannot be repaired and, if faulty or damaged, it must be replaced. Refer to Group 7 - Cooling System for more information on the engine cooling system, the engine coolant and the heater hoses.

HIGH PRESSURE CUT-OFF SWITCH

The high pressure cut-off switch is located on the discharge line or discharge line block fitting near the compressor. The switch is screwed onto a fitting that contains a Schrader-type valve, which allows the switch to be serviced without discharging the refrigerant system. The discharge line fitting is equipped with an O-ring to seal the switch connection.

The high pressure cut-off switch is connected in series electrically with the low pressure cycling clutch switch between ground and the Powertrain Control Module (PCM). The switch contacts open and close causing the PCM to turn the compressor clutch on and off. This prevents compressor operation when the discharge line pressure approaches high levels.

The high pressure cut-off switch contacts are open when the discharge line pressure rises above 3100 to 3375 kPa (450 to 490 psi). The switch contacts will close when the discharge line pressure drops to 1860 to 2275 kPa (270 to 330 psi).

The high pressure cut-off switch is a factory-calibrated unit. The switch cannot be adjusted or repaired and, if faulty or damaged, it must be replaced.

HIGH PRESSURE RELIEF VALVE

A high pressure relief valve is located on the compressor manifold, which is on the side of the compressor. This mechanical valve is designed to vent refrigerant from the system to protect against damage to the compressor and other system components, caused by condenser air flow restriction or an over-charge of refrigerant.

The high pressure relief valve vents the system when a discharge pressure of 3445 to 4135 kPa (500 to 600 psi) or above is reached. The valve closes when a minimum discharge pressure of 2756 kPa (400 psi) is reached.

The high pressure relief valve vents only enough refrigerant to reduce the system pressure, and then re-seats itself. The majority of the refrigerant is conserved in the system. If the valve vents refrigerant, it does not mean that the valve is faulty.

The high pressure relief valve is a factory-calibrated unit. The valve cannot be adjusted or repaired, and must not be removed or otherwise disturbed. The valve is only serviced as a part of the compressor assembly.

DESCRIPTION AND OPERATION (Continued)**IN-VEHICLE TEMPERATURE SENSOR**

Models equipped with the optional Automatic Temperature Control (ATC) system have an in-vehicle temperature sensor. The in-vehicle temperature sensor is located in the instrument panel, just inboard of the glove box and below the passenger side center panel outlet. The ATC control module uses the in-vehicle temperature sensor signal input to adjust the blower speed, blend-air door position, and mode door selection in order to maintain the selected comfort level.

The in-vehicle temperature sensor is a Negative Temperature Coefficient (NTC) thermistor, which is a temperature sensitive resistor. Air passing over a venturi in the heater-A/C housing creates a vacuum, which draws air from inside the vehicle through a grille opening in the instrument panel past the sensor and through an aspirator hose and tube into the heater-A/C housing. The sensor provides a signal to the ATC control module with a value that represents the temperature of the air inside the vehicle.

The in-vehicle temperature sensor cannot be adjusted or repaired and, if faulty or damaged, it must be replaced.

LOW PRESSURE CYCLING CLUTCH SWITCH

The low pressure cycling clutch switch is located on the top of the accumulator. The switch is screwed onto an accumulator fitting that contains a Schrader-type valve, which allows the switch to be serviced without discharging the refrigerant system. The accumulator fitting is equipped with an O-ring to seal the switch connection.

The low pressure cycling clutch switch is connected in series electrically with the high pressure cut-off switch, between ground and the Powertrain Control Module (PCM). The switch contacts open and close causing the PCM to turn the compressor clutch on and off. This regulates the refrigerant system pressure and controls evaporator temperature. Controlling the evaporator temperature prevents condensate water on the evaporator fins from freezing and obstructing air conditioning system air flow.

The low pressure cycling clutch switch contacts are open when the suction pressure is approximately 141 kPa (20.5 psi) or lower. The switch contacts will close when the suction pressure rises to approximately 234 to 262 kPa (34 to 38 psi) or above. Lower ambient temperatures, below approximately -1° C (30° F), will also cause the switch contacts to open. This is due to the pressure/temperature relationship of the refrigerant in the system.

The low pressure cycling clutch switch is a factory-calibrated unit. It cannot be adjusted or repaired and, if faulty or damaged, it must be replaced.

REFRIGERANT

The refrigerant used in this air conditioning system is a HydroFluoroCarbon (HFC), type R-134a. Unlike R-12, which is a ChloroFluoroCarbon (CFC), R-134a refrigerant does not contain ozone-depleting chlorine. R-134a refrigerant is a non-toxic, non-flammable, clear, and colorless liquefied gas.

Even though R-134a does not contain chlorine, it must be reclaimed and recycled just like CFC-type refrigerants. This is because R-134a is a greenhouse gas and can contribute to global warming.

R-134a refrigerant is not compatible with R-12 refrigerant in an air conditioning system. Even a small amount of R-12 added to an R-134a refrigerant system will cause compressor failure, refrigerant oil sludge or poor air conditioning system performance. In addition, the PolyAlkylene Glycol (PAG) synthetic refrigerant oils used in an R-134a refrigerant system are not compatible with the mineral-based refrigerant oils used in an R-12 refrigerant system.

R-134a refrigerant system service ports, service tool couplers and refrigerant dispensing bottles have all been designed with unique fittings to ensure that an R-134a system is not accidentally contaminated with the wrong refrigerant (R-12). There are also labels posted in the engine compartment of the vehicle and on the compressor identifying to service technicians that the air conditioning system is equipped with R-134a.

REFRIGERANT LINE

The refrigerant lines and hoses are used to carry the refrigerant between the various air conditioning system components. A barrier hose design with a nylon tube inner hose liner is used for the R-134a air conditioning system on this vehicle. This nylon liner helps to further contain the R-134a refrigerant, which has a smaller molecular structure than R-12 refrigerant. The ends of the refrigerant hoses are made from lightweight aluminum, and use braze-less fittings.

Any kinks or sharp bends in the refrigerant plumbing will reduce the capacity of the entire air conditioning system. Kinks and sharp bends reduce the flow of refrigerant in the system. A good rule for the flexible hose refrigerant lines is to keep the radius of all bends at least ten times the diameter of the hose. In addition, the flexible hose refrigerant lines should be routed so they are at least 80 millimeters (3 inches) from the exhaust manifold.

High pressures are produced in the refrigerant system when the air conditioning compressor is operating. Extreme care must be exercised to make sure that each of the refrigerant system connections is pressure-tight and leak free. It is a good practice to inspect all flexible hose refrigerant lines at least once

DESCRIPTION AND OPERATION (Continued)

a year to make sure they are in good condition and properly routed.

The refrigerant lines and hoses cannot be repaired and, if faulty or damaged, they must be replaced.

REFRIGERANT LINE COUPLER

Spring-lock type refrigerant line couplers are used to connect many of the refrigerant lines and other components to the refrigerant system. These couplers require a special tool for disengaging the two coupler halves.

The spring-lock coupler is held together by a garter spring inside a circular cage on the male half of the fitting (Fig. 6). When the two coupler halves are connected, the flared end of the female fitting slips behind the garter spring inside the cage on the male fitting. The garter spring and cage prevent the flared end of the female fitting from pulling out of the cage.

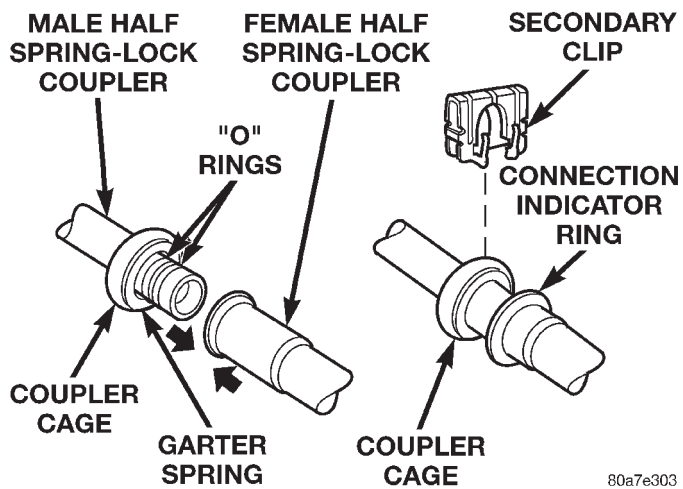


Fig. 6 Spring-Lock Coupler - Typical

Two O-rings on the male half of the fitting are used to seal the connection. These O-rings are compatible with R-134a refrigerant and must be replaced with O-rings made of the same material.

Secondary clips are installed over the two connected coupler halves at the factory for added blowoff protection. In addition, a plastic ring is used at the factory as a visual indicator to confirm that these couplers are connected. After the coupler is connected, the plastic indicator ring is no longer needed; however, it will remain on the refrigerant line near the coupler cage.

REFRIGERANT OIL

The refrigerant oil used in R-134a refrigerant systems is a synthetic-based, PolyAlkylene Glycol (PAG), wax-free lubricant. Mineral-based R-12 refrigerant oils are not compatible with PAG oils, and should never be introduced to an R-134a refrigerant system.

There are different PAG oils available, and each contains a different additive package. The 10PA17

compressor used in this vehicle is designed to use an ND8 PAG refrigerant oil. Use only refrigerant oil of this same type to service the refrigerant system.

After performing any refrigerant recovery or recycling operation, always replenish the refrigerant system with the same amount of the recommended refrigerant oil as was removed. Too little refrigerant oil can cause compressor damage, and too much can reduce air conditioning system performance.

PAG refrigerant oil is much more hygroscopic than mineral oil, and will absorb any moisture it comes into contact with, even moisture in the air. The PAG oil container should always be kept tightly capped until it is ready to be used. After use, recap the oil container immediately to prevent moisture contamination.

REFRIGERANT SYSTEM SERVICE EQUIPMENT

WARNING: EYE PROTECTION MUST BE WORN WHEN SERVICING AN AIR CONDITIONING REFRIGERANT SYSTEM. TURN OFF (ROTATE CLOCKWISE) ALL VALVES ON THE EQUIPMENT BEING USED BEFORE CONNECTING TO, OR DISCONNECTING FROM THE REFRIGERANT SYSTEM. FAILURE TO OBSERVE THESE WARNINGS MAY RESULT IN PERSONAL INJURY.

When servicing the air conditioning system, a R-134a refrigerant recovery/recycling/charging station that meets SAE Standard J2210 must be used. Contact an automotive service equipment supplier for refrigerant recovery/recycling/charging equipment. Refer to the operating instructions supplied by the equipment manufacturer for proper care and use of this equipment.

A manifold gauge set may be needed with some recovery/recycling/charging equipment (Fig. 7). The service hoses on the gauge set being used should have manual (turn wheel), or automatic back-flow valves at the service port connector ends. This will prevent refrigerant from being released into the atmosphere.

MANIFOLD GAUGE SET CONNECTIONS

CAUTION: Do not use an R-12 manifold gauge set on an R-134a system. The refrigerants are not compatible and system damage will result.

LOW PRESSURE GAUGE HOSE

The low pressure hose (Blue with Black stripe) attaches to the suction service port. This port is located on the liquid line, near the evaporator at the rear of the engine compartment.

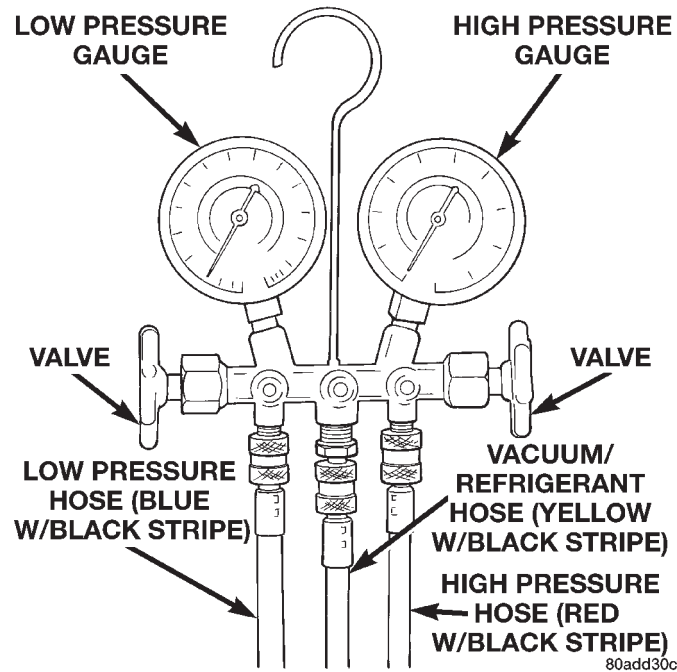
DESCRIPTION AND OPERATION (Continued)

Fig. 7 Manifold Gauge Set - Typical

HIGH PRESSURE GAUGE HOSE

The high pressure hose (Red with Black stripe) attaches to the discharge service port. This port is located on the compressor manifold on the side of the compressor.

RECOVERY/RECYCLING/EVACUATION/CHARGING HOSE

The center manifold hose (Yellow, or White, with Black stripe) is used to recover, evacuate, and charge the refrigerant system. When the low or high pressure valves on the manifold gauge set are opened, the refrigerant in the system will escape through this hose.

REFRIGERANT SYSTEM SERVICE PORT

The two refrigerant system service ports are used to charge, recover/recycle, evacuate, and test the air conditioning refrigerant system. Unique service port coupler sizes are used on the R-134a system, to ensure that the refrigerant system is not accidentally contaminated by the use of the wrong refrigerant (R-12), or refrigerant system service equipment.

The high pressure service port is located on the compressor manifold on the side of the compressor. The low pressure service port is located on the liquid line near the evaporator at the rear of the engine compartment.

Each of the service ports has a threaded plastic protective cap installed over it from the factory. After servicing the refrigerant system, always reinstall both of the service port caps.

SOLAR SENSOR

Models equipped with the optional Automatic Temperature Control (ATC) system have a solar sensor. The solar sensor is mounted in the cowl top trim panel, on the top of the instrument panel near the passenger side defroster outlet. The sensor is a photo diode which responds to sunlight intensity, not to temperature.

The ATC control module uses the solar sensor input to calculate and compensate for the potential effects of heat gain in bright sunlight, and heat loss with an overcast sky or at night. It then adjusts the blower motor speed, blend air door position, and mode door position as needed to maintain the selected comfort level.

The solar sensor cannot be adjusted or repaired and, if faulty or damaged, it must be replaced.

VACUUM CHECK VALVE

A vacuum check valve is installed in the accessory vacuum supply line in the engine compartment, near the vacuum tap on the engine intake manifold. The vacuum check valve is designed to allow vacuum to flow in only one direction through the accessory vacuum supply circuits.

The use of a vacuum check valve helps to maintain the system vacuum needed to retain the selected heater-A/C mode settings. The check valve will prevent the engine from bleeding down system vacuum through the intake manifold during extended heavy engine load (low engine vacuum) operation.

The vacuum check valve cannot be repaired and, if faulty or damaged, it must be replaced.

VACUUM RESERVOIR

The vacuum reservoir is mounted in the engine compartment on the underside of the battery tray. The battery and battery tray must be removed from the vehicle to access the vacuum reservoir for service.

Engine vacuum is stored in the vacuum reservoir. The stored vacuum is used to operate the vacuum-controlled vehicle accessories during periods of low engine vacuum such as when the vehicle is climbing a steep grade, or under other high engine load operating conditions.

The vacuum reservoir cannot be repaired and, if faulty or damaged, it must be replaced.

DIAGNOSIS AND TESTING**A/C PERFORMANCE**

The air conditioning system is designed to provide the passenger compartment with low temperature and low humidity air. The evaporator, located in the heater-A/C housing on the dash panel below the instrument panel, is cooled to temperatures near the freezing point. As warm damp air passes through the

DIAGNOSIS AND TESTING (Continued)

cooled evaporator, the air transfers its heat to the refrigerant in the evaporator and the moisture in the air condenses on the evaporator fins. During periods of high heat and humidity, an air conditioning system will be more effective in the Recirculation Mode. With the system in the Recirculation Mode, only air from the passenger compartment passes through the evaporator. As the passenger compartment air dehumidifies, the air conditioning system performance levels improve.

Humidity has an important bearing on the temperature of the air delivered to the interior of the vehicle. It is important to understand the effect that humidity has on the performance of the air conditioning system. When humidity is high, the evaporator has to perform a double duty. It must lower the air temperature, and it must lower the temperature of the moisture in the air that condenses on the evaporator fins. Condensing the moisture in the air transfers heat energy into the evaporator fins and tubing. This reduces the amount of heat the evaporator can absorb from the air. High humidity greatly reduces the ability of the evaporator to lower the temperature of the air.

However, evaporator capacity used to reduce the amount of moisture in the air is not wasted. Wringing some of the moisture out of the air entering the vehicle adds to the comfort of the passengers. Although, an owner may expect too much from their air conditioning system on humid days. A performance test is the best way to determine whether the system is performing up to standard. This test also provides valuable clues as to the possible cause of trouble with the air conditioning system.

If the vehicle has the optional Automatic Temperature Control (ATC) system, and has intermittent operational problems or fault codes, be certain that the 16-way wire harness connector on the heater-A/C housing is properly seated (Fig. 8). To check this condition, unplug the two wire harness connector halves, then plug them in again. Historical fault codes that could be stored as a result of this unseated wire harness connector condition are Codes 36, 38, and 39.

Review the Service Warnings and Precautions in the front of this group before performing this procedure. The air temperature in the test room and in the vehicle must be a minimum of 21° C (70° F) for this test.

(1) Connect a tachometer and a manifold gauge set.

(2) If the vehicle has the standard manual temperature control, set the heater-A/C mode control switch knob in the Panel position, the temperature control knob in the full cool (Recirculation Mode) position, the A/C button in the On position, and the blower motor switch knob in the highest speed position. If the vehicle has the optional ATC, set the heater-A/C mode control switch knob in the Panel position, the temperature control knob in the full cool position, the A/C and Recirc

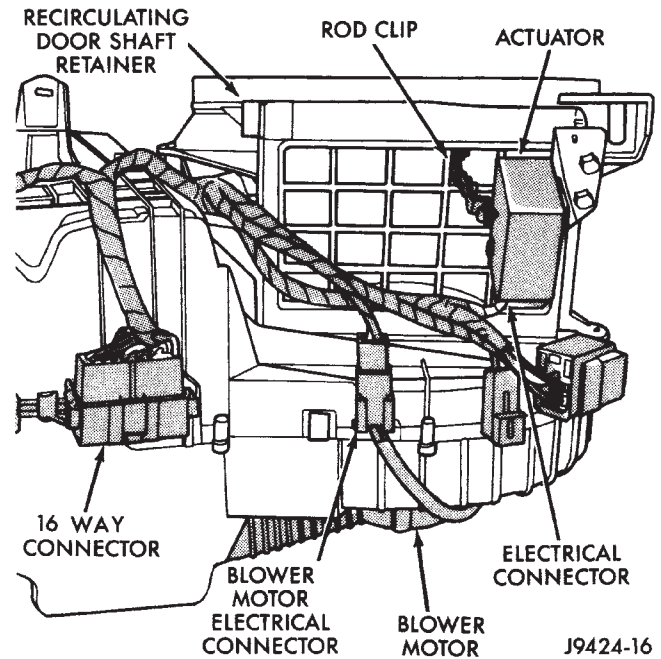


Fig. 8 16-Way Wire Harness Connector

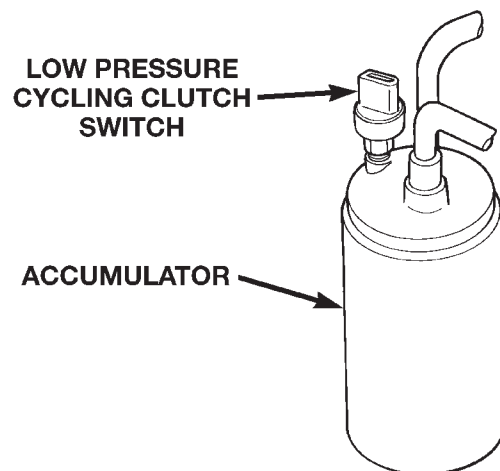
buttons in the On position, and the blower motor switch knob in the highest (manual) speed position.

(3) Start the engine and hold the idle at 1,000 rpm with the compressor clutch engaged.

(4) The engine should be at operating temperature. The doors and windows must be open.

(5) Insert a thermometer in the driver side center A/C (panel) outlet. Operate the engine for five minutes.

(6) The compressor clutch may cycle, depending upon the ambient temperature and humidity. If the clutch cycles, unplug the low pressure cycling clutch switch wire harness connector from the switch located on the accumulator (Fig. 9). Place a jumper wire across the terminals of the low pressure cycling clutch switch wire harness connector.



80add30d

Fig. 9 Low Pressure Cycling Clutch Switch - Typical

DIAGNOSIS AND TESTING (Continued)

Performance Temperature and Pressure					
Ambient Air Temperature	21° C (70° F)	27° C (80° F)	32° C (90° F)	38° C (100° F)	43° C (110° F)
Air Temperature at Center Panel Outlet	-3 to 3° C (27 to 38° F)	1 to 7° C (33 to 44° F)	3 to 9° C (37 to 48° F)	6 to 13° C (43 to 55° F)	10 to 18° C (50 to 64° F)
Evaporator Inlet Pressure at Charge Port	179 to 241 kPa (26 to 35 psi)	221 to 283 kPa (32 to 41 psi)	262 to 324 kPa (38 to 47 psi)	303 to 365 kPa (44 to 53 psi)	345 to 414 kPa (50 to 60 psi)
Compressor Discharge Pressure	1240 to 1655 kPa (180 to 240 psi)	1380 to 1790 kPa (200 to 260 psi)	1720 to 2070 kPa (250 to 300 psi)	1860 to 2345 kPa (270 to 340 psi)	2070 to 2690 kPa (300 to 390 psi)

(7) With the compressor clutch engaged, record the discharge air temperature and the compressor discharge pressure.

(8) Compare the discharge air temperature to the Performance Temperature and Pressure chart. If the discharge air temperature is high, see Refrigerant

System Leaks and Refrigerant System Charge in this group.

(9) Compare the compressor discharge pressure to the Performance Temperature and Pressure chart. If the compressor discharge pressure is high, see the Pressure Diagnosis chart.

Pressure Diagnosis		
Condition	Possible Causes	Correction
Rapid compressor clutch cycling (ten or more cycles per minute).	1. Low refrigerant system charge.	1. See Refrigerant System Leaks in this group. Test the refrigerant system for leaks. Repair, evacuate and charge the refrigerant system, if required.
Equal pressures, but the compressor clutch does not engage.	1. No refrigerant in the refrigerant system. 2. Faulty fuse. 3. Faulty compressor clutch coil. 4. Faulty compressor clutch relay. 5. Improperly installed or faulty low pressure cycling clutch switch. 6. Faulty high pressure cut-off switch. 7. Faulty Powertrain Control Module (PCM).	1. See Refrigerant System Leaks in this group. Test the refrigerant system for leaks. Repair, evacuate and charge the refrigerant system, if required. 2. Check the fuses in the Power Distribution Center and the fuseblock module. Repair the shorted circuit or component and replace the fuses, if required. 3. See Compressor Clutch Coil in this group. Test the compressor clutch coil and replace, if required. 4. See Compressor Clutch Relay in this group. Test the compressor clutch relay and relay circuits. Repair the circuits or replace the relay, if required. 5. See Low Pressure Cycling Clutch Switch in this group. Test the low pressure cycling clutch switch and tighten or replace, if required. 6. See High Pressure Cut-Off Switch in this group. Test the high pressure cut-off switch and replace, if required. 7. Refer to the proper Diagnostic Procedures manual for testing of the PCM. Test the PCM and replace, if required.
Normal pressures, but A/C Performance Test air temperatures at center panel outlet are too high.	1. Excessive refrigerant oil in system. 2. Temperature control cable improperly installed or faulty. 3. Blend-air door inoperative or sealing improperly.	1. See Refrigerant Oil Level in this group. Recover the refrigerant from the refrigerant system and inspect the refrigerant oil content. Restore the refrigerant oil to the proper level, if required. 2. See Temperature Control Cable in this group. Inspect the temperature control cable for proper routing and operation and correct, if required. 3. See Blend-Air Door under Heater-A/C Housing Door in this group. Inspect the blend-air door for proper operation and sealing and correct, if required.

DIAGNOSIS AND TESTING (Continued)

Pressure Diagnosis		
Condition	Possible Causes	Correction
The low side pressure is normal or slightly low, and the high side pressure is too low.	<ol style="list-style-type: none"> 1. Low refrigerant system charge. 2. Refrigerant flow through the accumulator is restricted. 3. Refrigerant flow through the evaporator coil is restricted. 4. Faulty compressor. 	<ol style="list-style-type: none"> 1. See Refrigerant System Leaks in this group. Test the refrigerant system for leaks. Repair, evacuate and charge the refrigerant system, if required. 2. See Accumulator in this group. Replace the restricted accumulator, if required. 3. See Evaporator Coil in this group. Replace the restricted evaporator coil, if required. 4. See Compressor in this group. Replace the compressor, if required.
The low side pressure is normal or slightly high, and the high side pressure is too high.	<ol style="list-style-type: none"> 1. Condenser air flow restricted. 2. Inoperative cooling fan. 3. Refrigerant system overcharged. 4. Air in the refrigerant system. 5. Engine overheating. 	<ol style="list-style-type: none"> 1. Check the condenser for damaged fins, foreign objects obstructing air flow through the condenser fins, and missing or improperly installed air seals. Refer to Group 7 - Cooling System for more information on air seals. Clean, repair, or replace components as required. 2. Refer to Group 7 - Cooling System for more information. Test the cooling fan and replace, if required. 3. See Refrigerant System Charge in this group. Recover the refrigerant from the refrigerant system. Charge the refrigerant system to the proper level, if required. 4. See Refrigerant System Leaks in this group. Test the refrigerant system for leaks. Repair, evacuate and charge the refrigerant system, if required. 5. Refer to Group 7 - Cooling System for more information. Test the cooling system and repair, if required.
The low side pressure is too high, and the high side pressure is too low.	<ol style="list-style-type: none"> 1. Accessory drive belt slipping. 2. Fixed orifice tube not installed. 3. Faulty compressor. 	<ol style="list-style-type: none"> 1. Refer to Group 7 - Cooling System for more information. Inspect the accessory drive belt condition and tension. Tighten or replace the accessory drive belt, if required. 2. See Fixed Orifice Tube in this group. Install the missing fixed orifice tube, if required. 3. See Compressor in this group. Replace the compressor, if required.
The low side pressure is too low, and the high side pressure is too high.	<ol style="list-style-type: none"> 1. Restricted refrigerant flow through the refrigerant lines. 2. Restricted refrigerant flow through the fixed orifice tube. 3. Restricted refrigerant flow through the condenser. 	<ol style="list-style-type: none"> 1. See Liquid Line and Suction and Discharge Line in this group. Inspect the refrigerant lines for kinks, tight bends or improper routing. Correct the routing or replace the refrigerant line, if required. 2. See Fixed Orifice Tube in this group. Replace the restricted fixed orifice tube, if required. 3. See Condenser in this group. Replace the restricted condenser, if required.

HEATER PERFORMANCE

Before performing the following tests, refer to Group 7 - Cooling System for the procedures to check the radiator coolant level, serpentine drive belt tension, radiator air flow and the radiator fan operation. Also be certain that the accessory vacuum supply line is connected at the engine intake manifold.

MAXIMUM HEATER OUTPUT

Engine coolant is delivered to the heater core through two heater hoses. With the engine idling at

normal operating temperature, set the temperature control knob in the full hot position, the mode control switch knob in the floor heat position, and the blower motor switch knob in the highest speed position. Using a test thermometer, check the temperature of the air being discharged at the heater-A/C housing floor outlets. Compare the test thermometer reading to the Temperature Reference chart.

If the floor outlet air temperature is too low, refer to Group 7 - Cooling System to check the engine coolant temperature specifications. Both of the heater

DIAGNOSIS AND TESTING (Continued)

Temperature Reference				
Ambient Air Temperature	15.5° C (60° F)	21.1° C (70° F)	26.6° C (80° F)	32.2° C (90° F)
Minimum Air Temperature at Floor Outlet	62.2° C (144° F)	63.8° C (147° F)	65.5° C (150° F)	67.2° C (153° F)

hoses should be hot to the touch. The coolant return heater hose should be slightly cooler than the coolant supply heater hose. If the return hose is much cooler than the supply hose, locate and repair the engine coolant flow obstruction in the cooling system. Refer to Group 7 - Cooling System for the procedures.

OBSTRUCTED COOLANT FLOW

Possible locations or causes of obstructed coolant flow:

- Pinched or kinked heater hoses.
- Improper heater hose routing.
- Plugged heater hoses or supply and return ports at the cooling system connections.
- A plugged heater core.

If proper coolant flow through the cooling system is verified, and heater outlet air temperature is still low, a mechanical problem may exist.

MECHANICAL PROBLEMS

Possible locations or causes of insufficient heat:

- An obstructed cowl air intake.
- Obstructed heater system outlets.
- A blend-air door not functioning properly.

TEMPERATURE CONTROL

If the heater outlet air temperature cannot be adjusted with the temperature control knob on the heater-A/C control panel, the following could require service:

- The heater-A/C control.
- The blend air door actuator.
- The wire harness circuits for the heater-A/C control or the blend air door actuator.
- The blend-air door.
- Improper engine coolant temperature.

VACUUM SYSTEM

Vacuum control is used to operate the mode doors in the standard equipment manual temperature control system heater-A/C housing. Testing of the heater-A/C mode control switch operation will determine if the vacuum, and electrical controls are functioning. However, it is possible that a vacuum control system that operates perfectly at engine idle (high engine vacuum) may not function properly at high engine speeds or loads (low engine vacuum). This can be caused by leaks in the vacuum system, or a faulty vacuum check valve.

A vacuum system test will help to identify the source of poor vacuum system performance or vacuum system leaks. Before starting this test, stop the engine and make certain that the problem isn't a disconnected vacuum supply tube at the engine intake manifold vacuum tap or the vacuum reservoir.

Use an adjustable vacuum test set (Special Tool C-3707) and a suitable vacuum pump to test the heater-A/C vacuum control system. With a finger placed over the end of the vacuum test hose probe (Fig. 10), adjust the bleed valve on the test set gauge to obtain a vacuum of exactly 27 kPa (8 in. Hg.). Release and block the end of the probe several times to verify that the vacuum reading returns to the exact 27 kPa (8 in. Hg.) setting. Otherwise, a false reading will be obtained during testing.

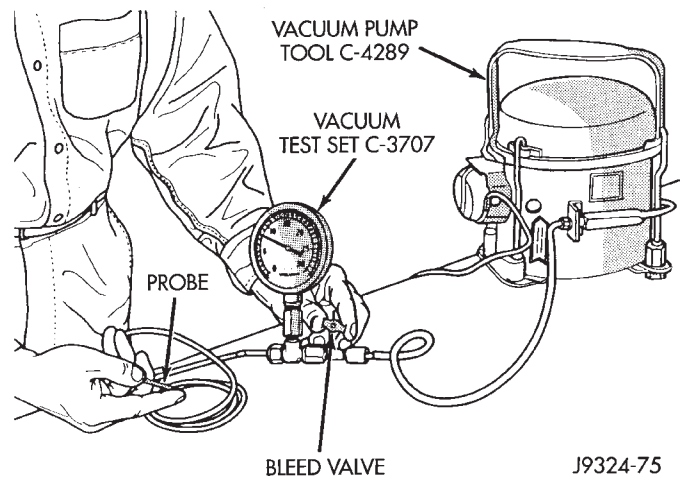


Fig. 10 Adjust Vacuum Test Bleed Valve

VACUUM CHECK VALVE

(1) Remove the vacuum check valve. The valve is located in the (black) vacuum supply tube at the engine intake manifold vacuum tap.

(2) Connect the test set vacuum supply hose to the heater-A/C control side of the valve. When connected to this side of the check valve, no vacuum should pass and the test set gauge should return to the 27 kPa (8 in. Hg.) setting. If OK, go to step Step 3. If not OK, replace the faulty valve.

(3) Connect the test set vacuum supply hose to the engine vacuum side of the valve. When connected to this side of the check valve, vacuum should flow through the valve without restriction. If not OK, replace the faulty valve.

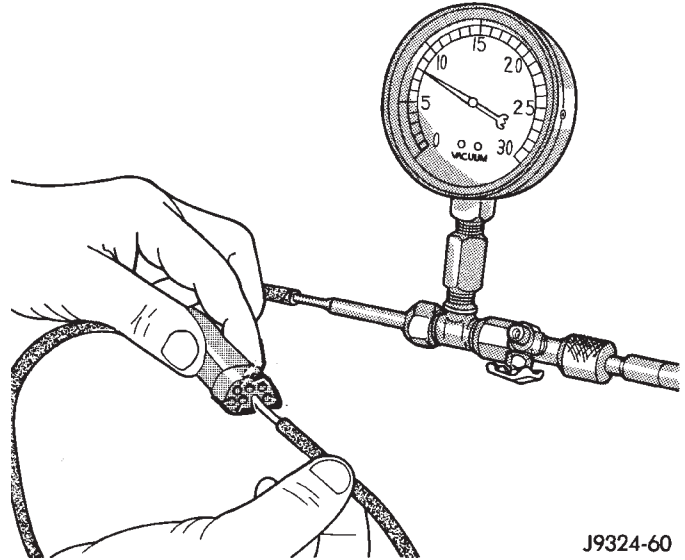
DIAGNOSIS AND TESTING (Continued)

HEATER-A/C CONTROLS

(1) Connect the test set vacuum probe to the heater-A/C vacuum supply (black) tube in the engine compartment. Position the test set gauge so that it can be viewed from the passenger compartment.

(2) Place the heater-A/C mode control switch knob in each mode position, one position at a time, and pause after each selection. The test set gauge should return to the 27 kPa (8 in. Hg.) setting shortly after each selection is made. If not OK, a component or vacuum line in the vacuum circuit of the selected mode has a leak. See the procedure in Locating Vacuum Leaks.

CAUTION: Do not use lubricant on the switch ports or in the holes in the plug, as lubricant will ruin the vacuum valve in the switch. A drop of clean water in the connector plug holes will help the connector slide onto the switch ports.



J9324-60

Fig. 11 Vacuum Circuit Test

LOCATING VACUUM LEAKS

WARNING: ON VEHICLES EQUIPPED WITH AIRBAGS, REFER TO GROUP 8M - PASSIVE RESTRAINT SYSTEMS BEFORE ATTEMPTING ANY STEERING WHEEL, STEERING COLUMN, OR INSTRUMENT PANEL COMPONENT DIAGNOSIS OR SERVICE. FAILURE TO TAKE THE PROPER PRECAUTIONS COULD RESULT IN ACCIDENTAL AIRBAG DEPLOYMENT AND POSSIBLE PERSONAL INJURY.

(1) Disconnect the vacuum harness connector from the back of the heater-A/C mode control switch on the control panel.

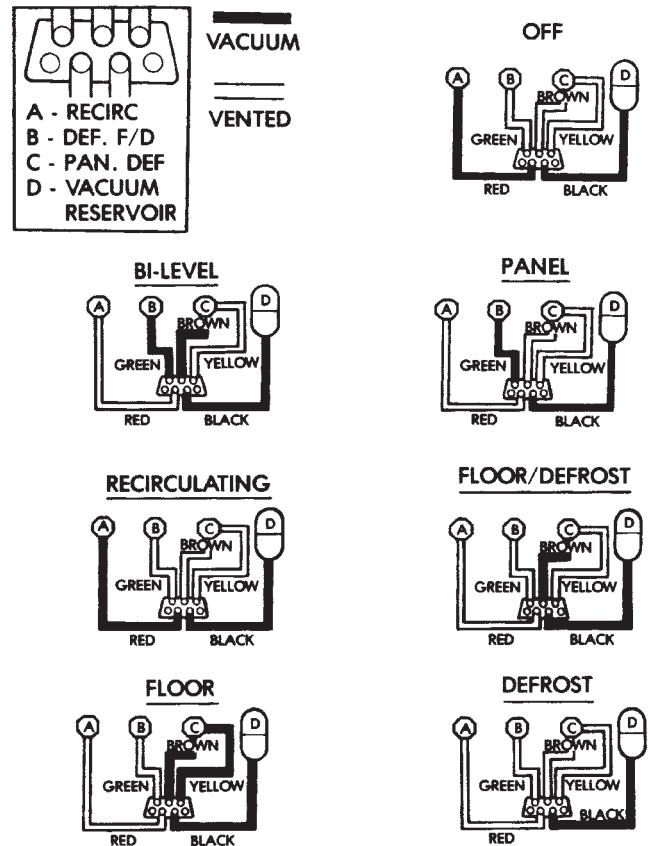
(2) Connect the test set vacuum hose probe to each port in the vacuum harness connector, one at a time, and pause after each connection (Fig. 11). The test set gauge should return to the 27 kPa (8 in. Hg.) setting shortly after each connection is made. If OK, replace the faulty mode control switch. If not OK, go to Step 3.

(3) Determine the vacuum line color of the vacuum circuit that is leaking. To determine the vacuum line colors, refer to the Vacuum Circuits chart (Fig. 12).

(4) Disconnect and plug the vacuum line from the component (fitting, actuator, valve, switch, or reservoir) on the other end of the leaking circuit. Instrument panel disassembly or removal may be necessary to gain access to some components.

(5) Connect the test set hose or probe to the open end of the leaking circuit. The test set gauge should return to the 27 kPa (8 in. Hg.) setting shortly after each connection is made. If OK, replace the faulty disconnected component. If not OK, go to Step 6.

(6) To locate a leak in a vacuum line, leave one end of the line plugged and connect the test set hose or



J9424-23

Fig. 12 Vacuum Circuits

probe to the other end. Run your fingers slowly along the line while watching the test set gauge. The vacuum reading will fluctuate when your fingers contact the source of the leak. To repair the vacuum line, cut out the leaking section of the line. Then, insert the loose ends of the line into a suitable length of 3 millimeter (1/8-inch) inside diameter rubber hose.

DIAGNOSIS AND TESTING (Continued)

AUTOMATIC TEMPERATURE CONTROL SYSTEM

The Automatic Temperature Control (ATC) control module has a system self-diagnostic mode. The ATC control module is capable of troubleshooting each of its input and output circuits. When the control module detects a fault and places it in memory, an "Er" is momentarily displayed in the heater-A/C control panel vacuum fluorescent display area, but it will only be displayed once during each ignition cycle. The ATC system can also be diagnosed using a DRB scan tool and the proper Diagnostic Procedures manual.

The ATC control module is capable of three different types of self-diagnostic tests, as follows:

- Fault Code Tests
- Input Circuit Tests
- Output Circuit/Actuator Tests

The information that follows describes how to read the self-diagnostic display, how to enter the ATC control module self-diagnostic test mode, how to select the three self-diagnostic test types, and how to perform the three different tests.

SELF-DIAGNOSTIC DISPLAY

In the self-diagnostic mode, the test information is displayed in the vacuum fluorescent display area of the heater-A/C control. The area of the display where the temperature control comfort level is normally displayed is called the Test Selector. The Test Selector is used to display fault codes, identify the test mode, and show the values of the circuits being tested. The following information describes how the values in the Test Selector display should be interpreted.

(1) The Select Test mode will have only 00 displayed in the Test Selector, and no stick man will be displayed. This is the self-diagnostic mode from which the various tests may be selected.

(2) If the stick man floor arrow (bottom) is showing, the displayed Test Selector value will be a range of numbers below zero (Fig. 13).

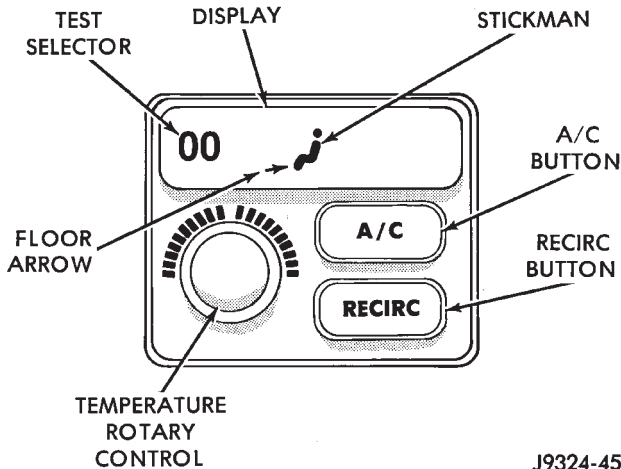


Fig. 13 Test Selector Values Below Zero

(3) If the stick man appears, but no arrows are showing, the displayed Test Selector value will be a range of numbers between zero and ninety-nine (Fig. 14).

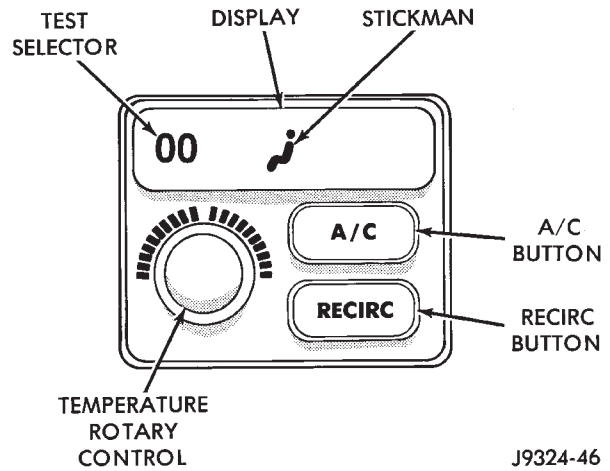


Fig. 14 Test Selector Values Between Zero and Ninety-Nine

(4) If the stick man panel arrow (middle) is showing, the displayed Test Selector value will be a range of numbers between 100 and 199 (Fig. 15).

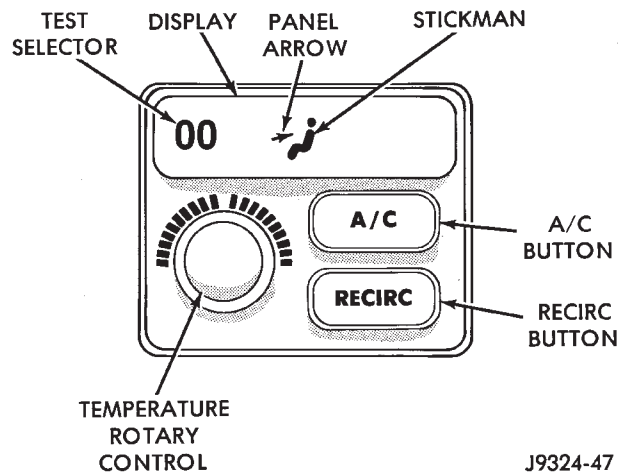


Fig. 15 Test Selector Values Between 100 and 199

(5) If the stick man panel (middle) and defrost (top) arrows are showing, the displayed Test Selector value will be a range of numbers between 200 and 255 (Fig. 16).

(6) At any time during the self-diagnostic tests, you may return to the Select Test mode by turning the rotary temperature control knob one click in either direction. Again, the stick man and arrows are not shown in the Select Test mode. At this point, you have the option of monitoring or testing another circuit (Fig. 17).

DIAGNOSIS AND TESTING (Continued)

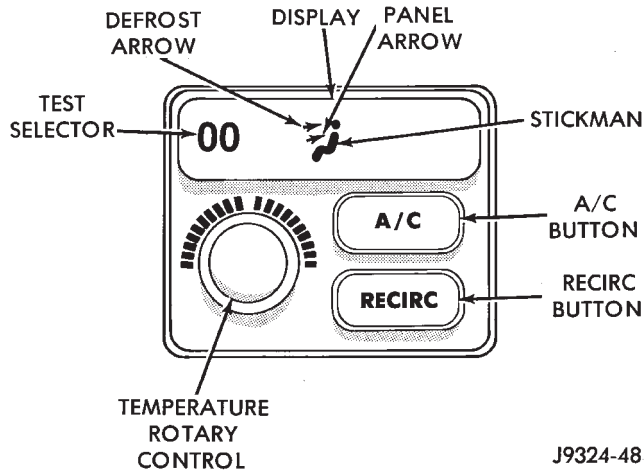


Fig. 16 Test Selector Values Between 200 and 255

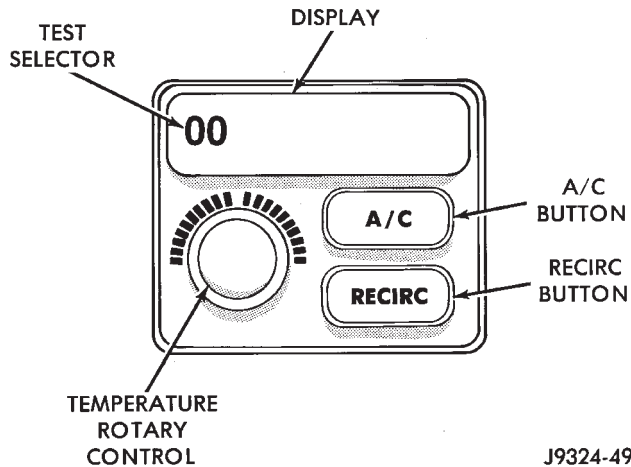


Fig. 17 Return to Select Test Mode

ENTERING THE ATC SELF-DIAGNOSTIC MODE

To enter the ATC self-diagnostic mode, perform the following:

(1) Depress the A/C and Recirc buttons at the same time and hold. Rotate the rotary temperature control knob clockwise one click.

(2) If you continue to hold the A/C and Recirc buttons depressed, the ATC control module will perform a Segment Test of the vacuum fluorescent display. In the Segment Test you should see all of the display segments illuminate. If a display segment fails to illuminate, the vacuum fluorescent display is faulty and the heater-A/C control must be replaced.

(3) After viewing the Segment Test, release the A/C and Recirc buttons. This will cause the Test Selector to display a "00" value, and no stick man will be displayed. This is the Select Test mode. At this point a number of tests can be selected, however, the Fault Code Test should be performed first.

FAULT CODE TESTS

Fault codes are two-digit numbers that identify a circuit that is malfunctioning. There are two different kinds of fault codes.

1. **Current Fault Codes** - Current means the fault is present right now. There are two types of current faults: input faults, and system faults.

2. **Historical Fault Codes** - Historical or stored means that the fault occurred previously, but is not present right now. A majority of historical fault codes are caused by intermittent wire harness or wire harness connector problems.

NOTE: A battery disconnect will erase all faults stored in Read Available Memory (RAM) of the ATC control module. It is recommended that all faults be recorded before they are erased.

RETRIEVING FAULT CODES

(1) To begin the Fault Code Tests you must be in the Select Test mode. With a "00" value displayed in the Test Selector and no stick man, push either the A/C or Recirc button.

(2) The stick man will appear indicating you have entered the Fault Code Tests. The values displayed in the Test Selector will range from "00" to "64."

(3) Fault codes will appear and repeat if there are more than one. Record all of the fault codes, then see the Current and Historical Fault Code charts for the descriptions. If there are no fault codes, the "00" display value will remain displayed in the Test Selector.

(4) If a Fault Code "25" or "29" is displayed, the ATC control module must be replaced before any further testing is performed.

(5) For more detailed information about a fault code, see the Input Circuit Tests or the Output Circuit/Actuator Tests.

CLEARING FAULT CODES

Current faults are cleared whenever the problem goes away. To clear a historical fault, depress and hold either the A/C or Recirc button for at least three seconds. The faults have been cleared when two horizontal bars appear in the Test Selector display.

DIAGNOSIS AND TESTING (Continued)

Current Fault Codes

Fail Code/Description	Circuit Description
00 = No Faults	
02 = Circuit open	In-Vehicle Temperature Sensor
03 = Circuit open	Solar Sensor Input Circuit
04 = Circuit open	Front Panel Blower/Fan Control Input
05 = Circuit open	Front Panel Mode Control Input
06 = Circuit open	Blend Air Door Feedback Circuit
07 = Circuit open	Mode Door Feedback Circuit
08 = Feedback too high	Blower /Fan Feedback Circuit
10 = Circuit shorted	In-Vehicle Temperature Sensor
11 = Circuit shorted	Solar Sensor Input Circuit
12 = Circuit shorted	Front Panel Blower/Fan Control Input
13 = Circuit shorted	Front Panel Mode Control Input
14 = Circuit shorted	Blend Air Door Feedback Circuit
15 = Circuit shorted	Mode Door Feedback Circuit
16 = Feedback too low	Blower/ Fan Feedback Circuit
19 = Door not responding	Mode Door Feedback Circuit
20 = Door not responding	Blend Air Door Actuator Drive Circuit
21 = Door travel range too small	Mode Door Feedback Circuit
22 = Door travel range too large	Mode Door Feedback Circuit
23 = Door travel range too small	Blend Air Door Actuator Drive Circuit
24 = Door travel range too large	Blend Air Door Actuator Drive Circuit
25 = Calibration data error	Calibration and CPU Data
26 = BCM message missing	Collision Detection C2D Bus Inputs
27 = PCM message Missing	Collision Detection C2D Bus Inputs
29 = CPU error	Calibration and CPU Data
30 = Reserved	
31 = Reserved	
32 = Reserved	

DIAGNOSIS AND TESTING (Continued)*Historical Fault Codes*

Fail Code/Description	Circuit Description
34 = Circuit was open	In-Vehicle Temperature Sensor
35 = Circuit was open	Solar Sensor Input Circuit
36 = Circuit was open	Front Panel Blower/Fan Control Input
37 = Circuit was open	Front Panel Mode Control Input
38 = Circuit was open	Blend Air Door Feedback Circuit
39 = Circuit was open	Mode Door Feedback Circuit
40 = Feedback was too high	Blower/Fan Feedback Circuit
42 = Circuit was shorted	In-Vehicle Temperature Sensor
43 = Circuit was shorted	Solar Sensor Input Circuit
44 = Circuit was shorted	Front Panel Blower/Fan Control Input
45 = Circuit was shorted	Front Panel Mode Control Input
46 = Circuit was shorted	Blend Air Door Feedback Circuit
47 = Circuit was shorted	Mode Door Feedback Circuit
48 = Feedback was too low	Blower/Fan Feedback Circuit
51 = Door was not responding	Mode Door Feedback Circuit
52 = Door was not responding	Blend Air Door Actuator Drive Circuit
53 = Door travel range was too small	Mode Door Feedback Circuit
54 = Door travel range was too large	Mode Door Feedback Circuit
55 = Door travel range was too small	Blend Air Door Actuator Drive Circuit
56 = Door travel range was too large	Blend Air Door Actuator Drive Circuit
57 = Calibration data was in error	Calibration and CPU Data
58 = BCM message was missing	Collision Detection C2D Bus Inputs
59 = PCM message was missing	Collision Detection C2D Bus Inputs
61 = CPU was in error	Calibration and CPU Data
62 = Reserved	
63 = Reserved	
64 = Reserved	

DIAGNOSIS AND TESTING (Continued)**INPUT CIRCUIT TESTS**

In the Input Circuit Test mode, the status of input circuits can be viewed and monitored. If a failure occurs within an input circuit, the ATC control module will display a “?” for unknown values, “OC” for an open circuit, or “SC” for a short circuit in the Test Selector display area.

(1) To begin the Input Circuit Tests you must be in the Select Test mode.

(2) With a “00” value displayed in the Test Selector and no stick man, turn the rotary temperature control knob until the test number you are looking for appears in the Test Selector display. See the Circuit Testing charts for a listing of the test numbers, test items, test types, system tested, and displayed values.

(3) To see the circuit input values, depress the A/C or Recirc button. The values displayed will represent the input seen by the ATC control module.

OUTPUT CIRCUIT/ACTUATOR TESTS

In the Output Circuit/Actuator Test mode, the output circuits can be viewed, monitored, overridden, and tested. If a failure occurs in an output circuit, test the circuit by overriding the system. Test the actuator through its full range of operation. When the override control has been activated, the Test Selector display will be flashing. The Test Selector will display feedback information about the output circuit being tested.

(1) To begin the Output Circuit/Actuator Tests you must be in the Select Test mode.

(2) With a “00” value displayed in the Test Selector and no stick man, turn the rotary temperature control knob until the test number you are looking for appears in the Test Selector display. See the Circuit Testing charts for a listing of the test numbers, test items, test types, system tested, and displayed values.

(3) To see the output value, depress the A/C or Recirc button. The values displayed will represent the output from the ATC control module.

(4) To enter the actuator test, depress the A/C or Recirc button. The Test Selector display will blink, indicating you are in the actuator test mode. Manual tests are those in which you will have to depress and hold the A/C or Recirc button to control the output. Automatic tests are those in which you will have to depress the A/C or Recirc button once to generate the output.

DIAGNOSIS AND TESTING (Continued)

Circuit Testing

Test No.	Test Item	Test Type	System Tested	Displayed Values
01	Blower Control Switch (A/D)	I	Blower System	"?" "OC" "SC" 00-255
02	Blower Feedback	I	Blower System	"?" 00-255
03	Blower Speed	O/A	Blower System	00-255
04	Hi Blower Relay	-	-	Not Equipped
05	Mode Control A/D	I	Mode Door System	"OC" "SC" 00-255
06	Mode Door Feedback	I	Mode Door System	"OC" "SC" 00-255
07	Panel Stop	I	Mode Door System	"?" 00-255
				If "?" is displayed, activate Mode 11 to find panel stop position.
08	Defrost Stop	I	Mode Door System	"?" 00-255
				If "?" is displayed, activate Mode 11 to find defrost stop position.
09	A/C Request	O/A	A/C System	00 = OFF 01 = ON
10	Mode Door Position	O/A	Mode Door System	00-255
				It is possible to command the door position beyond the stops. The motor will try to move there.
11	Mode Motor	O/A	Mode Door System	Pressing A/C or RECIRC button for 3 sec. begins reinitialization.
				00 = searching for panel stop 01 = searching for defrost stop 02 = moving toward panel 03 = moving toward defrost 04 = in position 05 = stalled moving toward panel 06 = stalled moving toward defrost 07 = feedback error
12	Mode Motor Drive Lines	O	Mode Door System	00 = stopped (lines low) 01 = toward defrost 02 = toward panel 03 = stopped (lines high)
13	Recirc Door	O/A	Recirc Door System	00 = continuous operation (lines grounded) 01 = fresh 02 = recirc. 03 = stopped (lines open)
14	In-Vehicle Temp. A/D	I	Temperature Inputs	"OC" "SC" 00-255
15	Blend Door Feedback	I	Blend Door System	"OC" "SC" 00-255
16	Blend Door Cold Stop	I	Blend Door System	"?" 00-255
17	Blend Door Hot Stop	I	Blend Door System	"?" 00-255

TEST TYPE: I = Input O = Output O/A = Output/Actuator

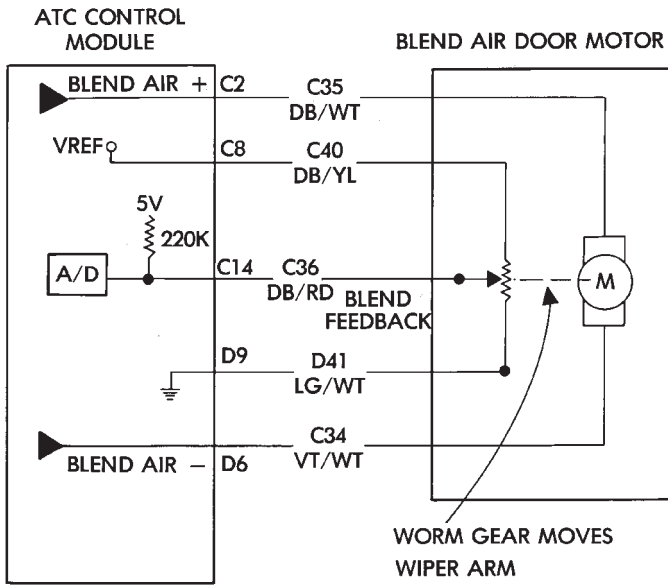
DIAGNOSIS AND TESTING (Continued)

Circuit Testing (cont.)

Test No.	Test Item	Test Type	System Tested	Displayed Values
19	In-Vehicle Temperature	I	Temperature Inputs	"OC" "SC" -40 to +60°C (-40 to + 140°F)
20	Ambient Sensor	I	CCD	-40 to +60°C (-40 to + 140°F)
21	Solar Sensor A/D	I	Sun Intensity Input	"OC" "SC" 00-255
22	Engine Coolant	I	CCD	"?" -40 to + 185°C (-40 to +260°F)
23	Vehicle Speed (MPH/KPM)	I	CCD	"?" 00-255
24	Engine RPM (x100)	I	CCD	00-82
25	Blend Door Motor	O/A	Blend Door System	Pressing A/C or RECIRC button for 3 sec. begins reinitialization.
				00 = searching for hot stop 01 = searching for cold stop 02 = moving to warmer 03 = moving to cooler 04 = in position 05 = stalled moving to warmer 06 = stalled moving to cooler 07 = feedback error
26	Blend Door Motor	O/A	Blend Door System	00-255
				It is possible to command the door position beyond the stops. The motor will try to move there.
27	Blend Door Motor Lines	O/A	Blend Door System	00 = stopped (lines low) 01 = toward cold 02 = toward hot 03 = stopped (lines high)
28	Lights On	I	Headlight Switch	00 = OFF 01 = ON
29	Dimming	I	PWD System	"?" 00-255
30	Dimming Level	O/A	Dimming System	"?" 00-255
31	ROM & EEPROM			00-FF
32	ROM & EEPROM			00-FF
33	ROM & EEPROM			00-FF
34	ROM & EEPROM			00-FF
35	ROM & EEPROM			00-FF
36	ROM & EEPROM			00-FF
37	ROM & EEPROM			00-FF
38	ROM & EEPROM			00-FF

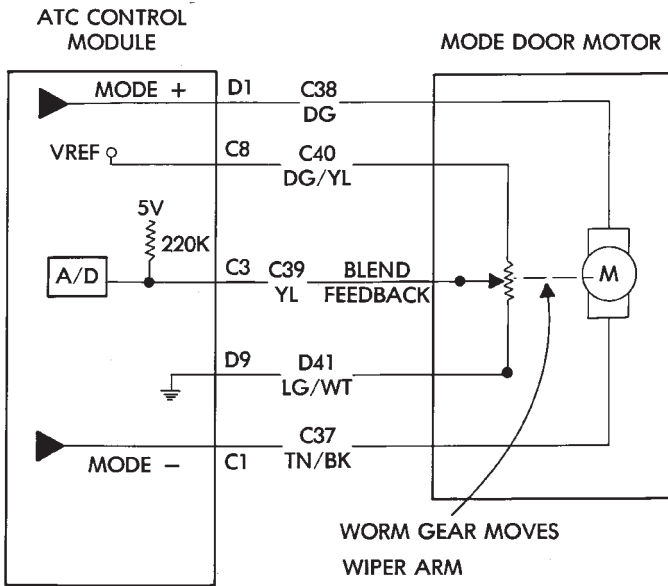
TEST TYPE: I = Input O = Output O/A = Output/Actuator

DIAGNOSIS AND TESTING (Continued)



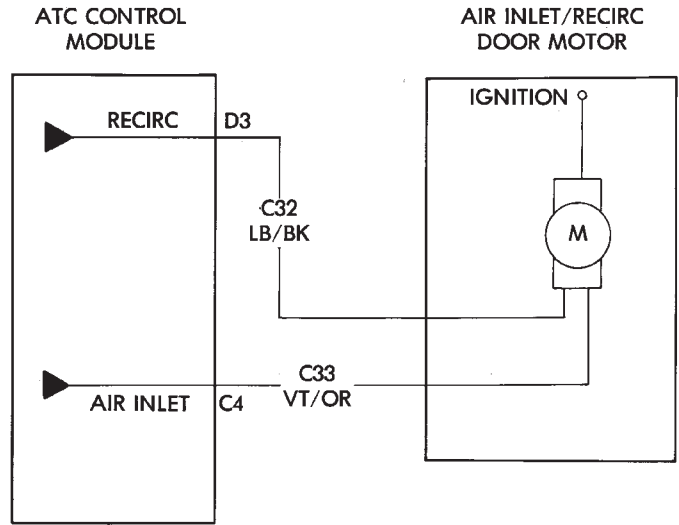
J9324-55

Blend Air Door Actuator Drive Circuit



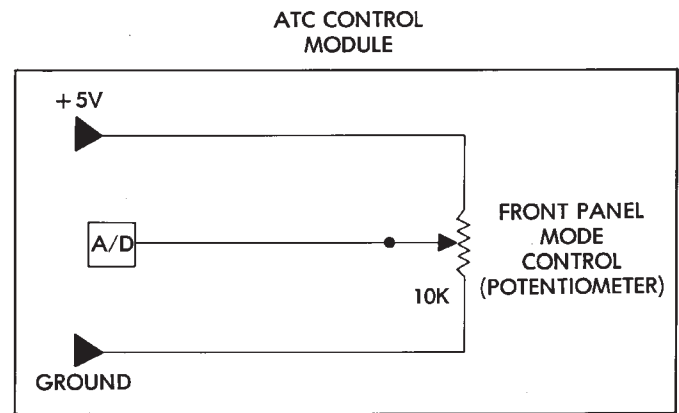
J9324-56

Mode Door Actuator Drive Circuit



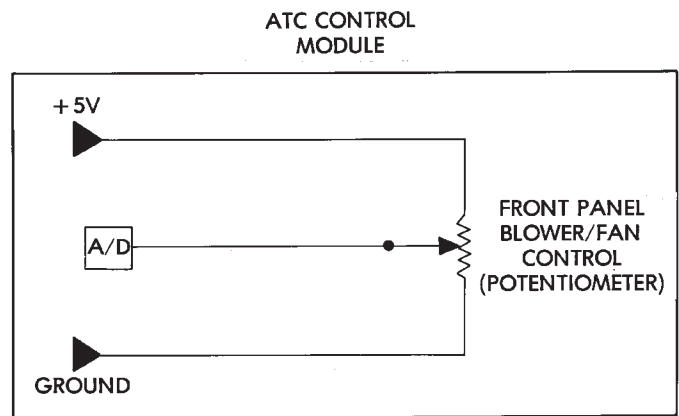
J9324-57

Air Inlet/Recirc Door Actuator Drive Circuit



J9324-58

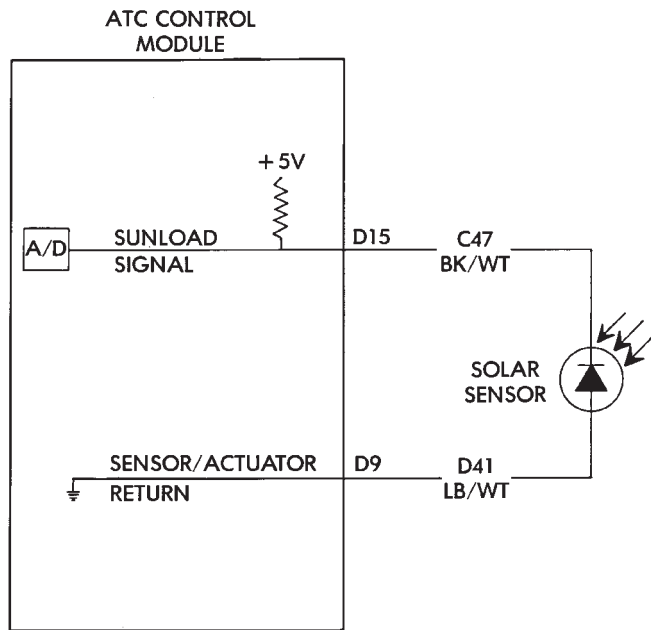
Front Panel Mode Control Circuit



J9324-61

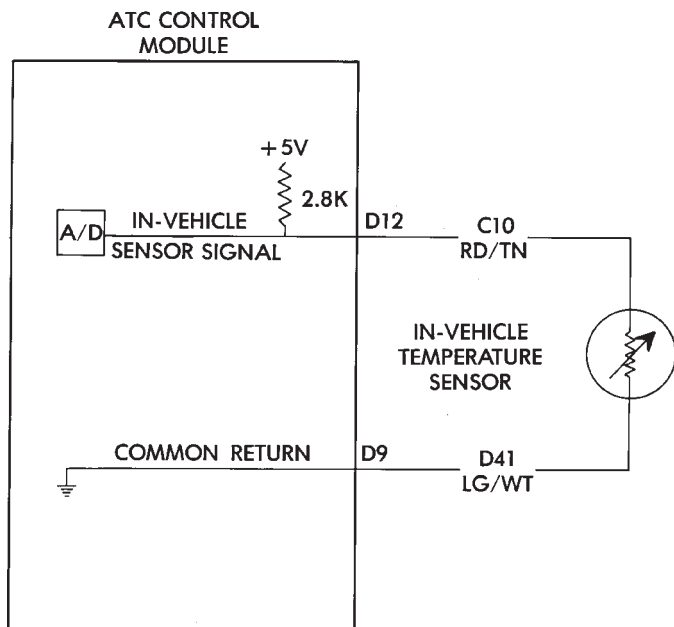
Front Panel Blower/Fan Control Circuit

DIAGNOSIS AND TESTING (Continued)



Solar Sensor Circuit

J9324-63

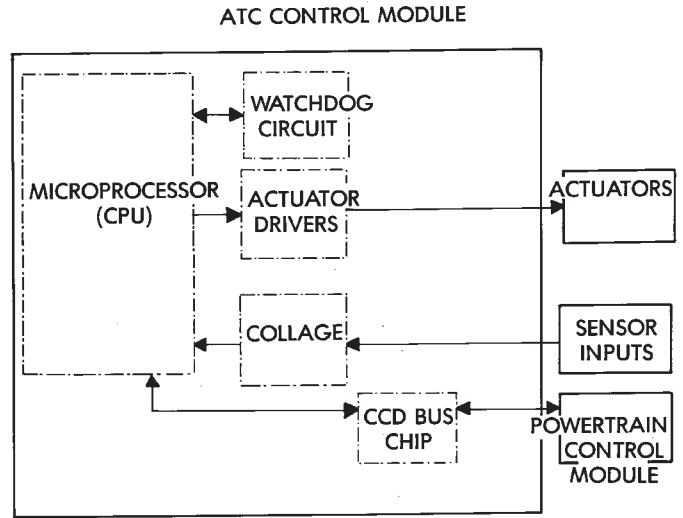


In-Vehicle Temperature Sensor Circuit

J9324-64

BLOWER MOTOR

WARNING: ON VEHICLES EQUIPPED WITH AIRBAGS, REFER TO GROUP 8M - PASSIVE RESTRAINT SYSTEMS BEFORE ATTEMPTING ANY STEERING WHEEL, STEERING COLUMN, OR INSTRUMENT PANEL COMPONENT DIAGNOSIS OR SERVICE. FAILURE TO TAKE THE PROPER PRECAUTIONS COULD RESULT IN ACCIDENTAL AIRBAG DEPLOYMENT AND POSSIBLE PERSONAL INJURY.



J9324-66

Calibration and CPU Data

For circuit descriptions and diagrams, refer to 8W-42 - Air Conditioning/Heater in Group 8W - Wiring Diagrams. Possible causes of an inoperative blower motor include:

- Faulty fuse
- Faulty blower motor circuit wiring or wire harness connections
- Faulty blower motor resistor (if the vehicle is so equipped)
- Faulty blower motor power module (if the vehicle is so equipped)
- Faulty blower motor switch
- Faulty heater-A/C mode control switch
- Faulty blower motor.

Possible causes of the blower motor not operating in all speeds include:

- Faulty fuse
- Faulty blower motor switch
- Faulty blower motor resistor (if the vehicle is so equipped)
- Faulty blower motor power module (if the vehicle is so equipped)
- Faulty ATC control module (if the vehicle is so equipped)
- Faulty blower motor circuit wiring or wire harness connections.

VIBRATION

Possible causes of blower motor vibration include:

- Improper blower motor mounting
- Improper blower wheel mounting
- Blower wheel out of balance or bent
- Blower motor faulty.

DIAGNOSIS AND TESTING (Continued)**NOISE**

To verify that the blower is the source of the noise, unplug the blower motor wire harness connector and operate the heater-A/C system. If the noise goes away, possible causes include:

- Foreign material in the heater-A/C housing
- Improper blower motor mounting
- Improper blower wheel mounting
- Blower motor faulty.

BLOWER MOTOR RESISTOR

For circuit descriptions and diagrams, refer to 8W-42 - Air Conditioning/Heater in Group 8W - Wiring Diagrams.

WARNING: ON VEHICLES EQUIPPED WITH AIR-BAGS, REFER TO GROUP 8M - PASSIVE RESTRAINT SYSTEMS BEFORE ATTEMPTING ANY STEERING WHEEL, STEERING COLUMN, OR INSTRUMENT PANEL COMPONENT DIAGNOSIS OR SERVICE. FAILURE TO TAKE THE PROPER PRECAUTIONS COULD RESULT IN ACCIDENTAL AIR-BAG DEPLOYMENT AND POSSIBLE PERSONAL INJURY.

(1) Disconnect and isolate the battery negative cable.

(2) Unplug the wire harness connector from the blower motor resistor.

(3) Check for continuity between each of the blower motor switch input terminals of the resistor and the resistor output terminal. In each case there should be continuity. If OK, repair the wire harness circuits between the blower motor switch and the blower motor resistor or blower motor as required. If not OK, replace the faulty blower motor resistor.

BLOWER MOTOR SWITCH

For circuit descriptions and diagrams, refer to 8W-42 - Air Conditioning/Heater in Group 8W - Wiring Diagrams.

WARNING: ON VEHICLES EQUIPPED WITH AIR-BAGS, REFER TO GROUP 8M - PASSIVE RESTRAINT SYSTEMS BEFORE ATTEMPTING ANY STEERING WHEEL, STEERING COLUMN, OR INSTRUMENT PANEL COMPONENT DIAGNOSIS OR SERVICE. FAILURE TO TAKE THE PROPER PRECAUTIONS COULD RESULT IN ACCIDENTAL AIR-BAG DEPLOYMENT AND POSSIBLE PERSONAL INJURY.

(1) Check for battery voltage at the fuse in the Power Distribution Center (PDC). If OK, go to Step 2. If not OK, repair the shorted circuit or component as required and replace the faulty fuse.

(2) Turn the ignition switch to the Off position. Disconnect and isolate the battery negative cable. Remove the heater-A/C control from the instrument panel. Check for continuity between the ground circuit cavity of the heater-A/C control wire harness connector and a good ground. There should be continuity. If OK, go to Step 3. If not OK, repair the open circuit to ground as required.

(3) With the heater-A/C control wire harness connector unplugged, place the heater-A/C mode control switch knob in any position except the Off position. Check for continuity between the ground circuit terminal and each of the blower motor driver circuit terminals of the heater-A/C control as you move the blower motor switch knob to each of the four speed positions. There should be continuity at each driver circuit terminal in only one blower motor switch speed position. If OK, test and repair the blower driver circuits between the heater-A/C control connector and the blower motor resistor as required. If not OK, replace the faulty heater-A/C control unit.

COMPRESSOR

When investigating an air conditioning related noise, you must first know the conditions under which the noise occurs. These conditions include: weather, vehicle speed, transmission in gear or neutral, engine temperature, and any other special conditions.

Noises that develop during air conditioning operation can often be misleading. For example: What sounds like a failed front bearing or connecting rod, may be caused by loose bolts, nuts, mounting brackets, or a loose clutch assembly. Verify serpentine drive belt tension. Improper belt tension can cause a misleading noise when the compressor is engaged. The noise may not occur when the compressor is disengaged.

Drive belts are speed sensitive. At different engine speeds and depending upon belt tension, belts can develop noises that are mistaken for a compressor noise.

(1) Select a quiet area for testing. Duplicate the complaint conditions as much as possible. Switch the compressor on and off several times to clearly identify the compressor noise. Listen to the compressor clutch while engaged and disengaged.

(2) To duplicate a high-ambient temperature condition (high head pressure), restrict the air flow through the condenser. Install a manifold gauge set to make sure that the discharge pressure does not exceed 2070 kPa (300 psi).

(3) Tighten all compressor mounting bolts, the clutch mounting nut, the clutch coil mounting screw or nut, and the serpentine drive belt to the correct specifications.

DIAGNOSIS AND TESTING (Continued)

- (4) Check the refrigerant system plumbing for rubbing or interference, which can cause unusual noises.
- (5) Check the refrigerant system charge. See Refrigerant System Charge in this group for the procedures.
- (6) Check the compressor noise as in Step 1.
- (7) If the noise still exists, loosen the compressor mounting bolts and tighten again. Repeat Step 1.
- (8) If the noise continues, replace the compressor and repeat Step 1.

COMPRESSOR CLUTCH COIL

For circuit descriptions and diagrams, refer to 8W-42 - Air Conditioning/Heater in Group 8W - Wiring Diagrams. The battery must be fully-charged before performing the following tests. Refer to Group 8A - Battery for more information.

- (1) Connect an ammeter (0 to 10 ampere scale) in series with the clutch coil terminal. Use a voltmeter (0 to 20 volt scale) with clip-type leads for measuring the voltage across the battery and the compressor clutch coil.
- (2) With the heater-A/C mode control switch in any A/C mode, the heater-A/C control A/C switch in the On position, and the blower motor switch in the lowest speed position, start the engine and run it at normal idle.
- (3) The compressor clutch coil voltage should read within two volts of the battery voltage. If there is voltage at the clutch coil, but the reading is not within two volts of the battery voltage, test the clutch coil feed circuit for excessive voltage drop and repair as required. If there is no voltage reading at the clutch coil, use a DRB scan tool and the proper Diagnostic Procedures manual for testing of the compressor clutch circuit. The following components must be checked and repaired as required before you can complete testing of the clutch coil:

- Fuses in the junction block and the Power Distribution Center (PDC)
- Heater-A/C mode control switch
- Compressor clutch relay
- High pressure cut-off switch
- Low pressure cycling clutch switch
- Powertrain Control Module (PCM).

(4) The compressor clutch coil is acceptable if the current draw measured at the clutch coil is 2.0 to 3.9 amperes with the electrical system voltage at 11.5 to 12.5 volts. This should only be checked with the work area temperature at 21° C (70° F). If system voltage is more than 12.5 volts, add electrical loads by turning on electrical accessories until the system voltage drops below 12.5 volts.

(a) If the clutch coil current reading is four amperes or more, the coil is shorted and should be replaced.

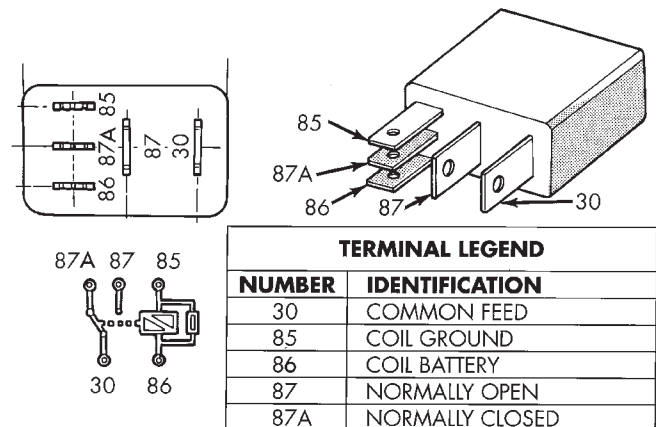
(b) If the clutch coil current reading is zero, the coil is open and should be replaced.

COMPRESSOR CLUTCH RELAY

For circuit descriptions and diagrams, refer to 8W-42 - Air Conditioning/Heater in Group 8W - Wiring Diagrams.

The compressor clutch relay (Fig. 18) is located in the Power Distribution Center (PDC). Refer to the PDC label for relay identification and location. Remove the relay from the PDC to perform the following tests:

- (1) A relay in the de-energized position should have continuity between terminals 87A and 30, and no continuity between terminals 87 and 30. If OK, go to Step 2. If not OK, replace the faulty relay.
- (2) Resistance between terminals 85 and 86 (electromagnet) should be 75 ± 5 ohms. If OK, go to Step 3. If not OK, replace the faulty relay.
- (3) Connect a battery to terminals 85 and 86. There should now be continuity between terminals 30 and 87, and no continuity between terminals 87A and 30. If OK, see the Relay Circuit Test procedure in this group. If not OK, replace the faulty relay.



9514-16

Fig. 18 Compressor Clutch Relay

RELAY CIRCUIT TEST

For circuit descriptions and diagrams, refer to 8W-42 - Air Conditioning/Heater in Group 8W - Wiring Diagrams.

(1) The relay common feed terminal cavity (30) is connected to fused battery feed. There should be battery voltage at the cavity for relay terminal 30 at all times. If OK, go to Step 2. If not OK, repair the open circuit to the fuse in the PDC as required.

(2) The relay normally closed terminal (87A) is not used in this application. Go to Step 3.

(3) The relay normally open terminal cavity (87) is connected to the compressor clutch coil. There should be continuity between this cavity and the A/C compressor clutch relay output circuit cavity of the com-

DIAGNOSIS AND TESTING (Continued)

pressor clutch coil wire harness connector. If OK, go to Step 4. If not OK, repair the open circuit as required.

(4) The relay coil battery terminal (86) is connected to the fused ignition switch output (run/start) circuit. There should be battery voltage at the cavity for relay terminal 86 with the ignition switch in the On position. If OK, go to Step 5. If not OK, repair the open circuit to the fuse in the junction block as required.

(5) The coil ground terminal cavity (85) is switched to ground through the Powertrain Control Module (PCM). There should be continuity between this cavity and the A/C compressor clutch relay control circuit cavity of the PCM wire harness connector C (gray) at all times. If not OK, repair the open circuit as required.

HIGH PRESSURE CUT-OFF SWITCH

Before performing diagnosis of the high pressure cut-off switch, verify that the refrigerant system has the correct refrigerant charge. See Refrigerant System Charge in this group for the procedures.

For circuit descriptions and diagrams, refer to 8W-42 - Air Conditioning/Heater in Group 8W - Wiring Diagrams.

(1) Disconnect and isolate the battery negative cable.

(2) Unplug the high pressure cut-off switch wire harness connector from the switch.

(3) Check for continuity between the two terminals of the high pressure cut-off switch. There should be continuity. If OK, test and repair the A/C switch sense circuit as required. If not OK, replace the faulty switch.

LOW PRESSURE CYCLING CLUTCH SWITCH

Before performing diagnosis of the low pressure cycling clutch switch, be certain that the switch is properly installed on the accumulator fitting. If the switch is too loose it may not open the Schrader-type valve in the accumulator fitting, which will prevent the switch from correctly monitoring the refrigerant system pressure.

Also verify that the refrigerant system has the correct refrigerant charge. See Refrigerant System Charge in this group for the procedures.

For circuit descriptions and diagrams, refer to 8W-42 - Air Conditioning/Heater in Group 8W - Wiring Diagrams.

(1) Disconnect and isolate the battery negative cable.

(2) Unplug the low pressure cycling clutch switch wire harness connector from the switch on the accumulator fitting.

(3) Install a jumper wire between the two cavities of the low pressure cycling clutch switch wire harness connector.

(4) Connect a manifold gauge set to the refrigerant system service ports. See Refrigerant System Service Equipment in this group for the procedures.

(5) Connect the battery negative cable.

(6) Place the heater-A/C mode control switch knob in any A/C position and start the engine.

(7) Check for continuity between the two terminals of the low pressure cycling clutch switch. There should be continuity with a suction pressure reading of 262 kPa (38 psi) or above, and no continuity with a suction pressure reading of 141 kPa (20.5 psi) or below. If OK, test and repair the A/C switch sense circuit as required. If not OK, replace the faulty switch.

REFRIGERANT SYSTEM LEAKS

WARNING: REVIEW THE WARNINGS AND CAUTIONS IN THE FRONT OF THIS GROUP BEFORE LEAK TESTING THE SYSTEM.

If the air conditioning system is not cooling properly, determine if the refrigerant system is fully-charged. See A/C Performance in this group for the procedures. If the refrigerant system is low or empty; a leak at a refrigerant line, connector fitting, component, or component seal is likely.

An electronic leak detector designed for R-134a refrigerant is recommended for locating and confirming refrigerant system leaks. Refer to the operating instructions supplied by the equipment manufacturer for proper care and use of this equipment.

An oily residue on or near refrigerant system lines, connector fittings, components, or component seals can indicate the general location of a possible refrigerant leak. However, the exact leak location should be confirmed with an electronic leak detector prior to component repair or replacement.

To detect a leak in the refrigerant system, perform one of the following procedures:

SYSTEM EMPTY

(1) Evacuate the refrigerant system. See Refrigerant System Evacuate in this group for the procedures.

(2) Connect and dispense 0.283 kilograms (0.625 pounds or 10 ounces) of R-134a refrigerant into the evacuated refrigerant system. See Refrigerant System Charge in this group for the procedures.

(3) Position the vehicle in a wind-free work area. This will aid in detecting small leaks.

(4) With the engine not running, use a electronic R-134a leak detector and search for leaks. Because R-134a refrigerant is heavier than air, the leak detec-

DIAGNOSIS AND TESTING (Continued)

tor probe should be moved slowly along the bottom side of all refrigerant lines, connector fittings and components.

(5) To inspect the evaporator coil for leaks, insert the electronic leak detector probe into the center instrument panel outlet. Set the blower motor switch to the lowest speed position, the A/C button in the On position, and select the Recirculation Mode.

SYSTEM LOW

(1) Position the vehicle in a wind-free work area. This will aid in detecting small leaks.

(2) Bring the refrigerant system up to operating temperature and pressure. This is done by allowing the engine to run with the air conditioning system turned on for five minutes.

(3) With the engine not running, use a electronic R-134a leak detector and search for leaks. Because R-134a refrigerant is heavier than air, the leak detector probe should be moved slowly along the bottom side of all refrigerant lines, connector fittings and components.

(4) To inspect the evaporator coil for leaks, insert the electronic leak detector probe into the center instrument panel outlet. Set the blower motor switch to the lowest speed position, the A/C button in the On position, and select the Recirculation Mode.

SERVICE PROCEDURES

REFRIGERANT RECOVERY

WARNING: REVIEW THE WARNINGS AND CAUTIONS IN THE FRONT OF THIS GROUP BEFORE RECOVERING REFRIGERANT.

A R-134a refrigerant recovery/recycling/charging station that meets SAE Standard J2210 must be used to recover the refrigerant from an R-134a refrigerant system. Refer to the operating instructions supplied by the equipment manufacturer for proper care and use of this equipment.

REFRIGERANT SYSTEM EVACUATE

WARNING: REVIEW THE WARNINGS AND CAUTIONS IN THE FRONT OF THIS GROUP BEFORE EVACUATING THE SYSTEM.

If the refrigerant system has been open to the atmosphere, it must be evacuated before the system can be charged. If moisture and air enters the system and becomes mixed with the refrigerant, the compressor head pressure will rise above acceptable operating levels. This will reduce the performance of the air conditioner and damage the compressor. Evacuating the refrigerant system will remove the

air and boil the moisture out of the system at near room temperature. To evacuate the refrigerant system, use the following procedure:

(1) Connect a R-134a refrigerant recovery/recycling/charging station that meets SAE Standard J2210 and a manifold gauge set to the refrigerant system of the vehicle.

(2) Open the low and high side valves and start the charging station vacuum pump. When the suction gauge reads 88 kPa (26 in. Hg.) vacuum or greater, close all of the valves and turn off the vacuum pump.

(a) If the refrigerant system fails to reach the specified vacuum, the system has a leak that must be corrected. See Refrigerant System Leaks in this group.

(b) If the refrigerant system maintains the specified vacuum for five minutes, restart the vacuum pump, open the suction and discharge valves and evacuate the system for an additional ten minutes.

(3) Close all of the valves, and turn off the charging station vacuum pump.

(4) The refrigerant system is now ready to be charged with R-134a refrigerant. See Refrigerant System Charge in this group for the procedures.

REFRIGERANT SYSTEM CHARGE

WARNING: REVIEW THE WARNINGS AND CAUTIONS IN THE FRONT OF THIS GROUP BEFORE CHARGING THE REFRIGERANT SYSTEM.

After the refrigerant system has been tested for leaks and evacuated, a refrigerant charge can be injected into the system. See Refrigerant Charge Capacity for the proper amount of the refrigerant charge.

A R-134a refrigerant recovery/recycling/charging station that meets SAE Standard J2210 must be used to charge the refrigerant system with R-134a refrigerant. Refer to the operating instructions supplied by the equipment manufacturer for proper care and use of this equipment.

REFRIGERANT CHARGE CAPACITY

The R-134a refrigerant system charge capacity for this vehicle is 0.737 kilograms (1.625 pounds).

PARTIAL CHARGE METHOD

WARNING: REVIEW THE WARNINGS AND CAUTIONS IN THE FRONT OF THIS GROUP BEFORE CHARGING THE REFRIGERANT SYSTEM.

The partial charge method is used to add a partial charge to a refrigerant system that is low on refrigerant. To perform this procedure the evaporator inlet

SERVICE PROCEDURES (Continued)

and outlet tube temperatures are measured. The temperature difference is measured with a temperature meter with one or two clamp-on thermocouple probes. The difference between the evaporator inlet and outlet tube temperatures will determine the amount of refrigerant needed.

Before adding a partial refrigerant charge, check for refrigerant system leaks. See Refrigerant System Leaks in this group for the procedures. If a leak is found, make the necessary repairs before attempting a full or partial refrigerant charge.

(1) Attach a manifold gauge set to the refrigerant system service ports.

(2) Attach the two clamp-on thermocouple probes to the inlet and outlet tubes of the evaporator coil.

a. If a single thermocouple probe is used, attach the probe to the evaporator inlet tube just before the collar of the refrigerant line connector fitting. The probe must make contact with the bottom surface of the evaporator inlet tube.

b. If dual thermocouple probes are used, attach probe 1 to the evaporator inlet tube, and probe 2 to the evaporator outlet tube. Attach both probes to the evaporator tubes just before the collar of the refrigerant line connector fittings. The probes must make contact with the bottom surfaces of the evaporator inlet and outlet tubes.

(3) Open all of the windows or doors of the passenger compartment.

(4) Set the A/C button on the heater-A/C controls to the on position, the temperature control knob in the full cool position, select the Recirculation Mode, and place the blower motor switch in the highest speed position.

(5) Start the engine and hold the engine idle speed at 1,000 rpm. Allow the engine to warm up to normal operating temperature.

(6) The compressor clutch may cycle, depending upon ambient temperature, humidity, and the refrigerant system charge level. If the compressor clutch cycles, unplug the wire harness connector from the low pressure cycling clutch switch on the accumulator. Install a jumper wire between the two cavities of the switch wire harness connector.

(7) Hold the engine idle speed at 1,000 rpm.

(8) Allow three to five minutes for the refrigerant system to stabilize, then record the temperatures of the evaporator inlet and outlet tubes.

c. If a single probe is used, record the temperature of the evaporator inlet tube. Then remove the probe from the inlet tube and attach it to the evaporator outlet tube just before the collar of the refrigerant line connector fitting. The probe must make contact with the bottom surface of the evaporator outlet tube. Allow the thermocouple and meter time to stabilize, then record the temperature of the evaporator outlet

tube. Subtract the inlet tube temperature reading from the outlet tube temperature reading.

d. If dual probes are used, record the temperatures of both the evaporator inlet and outlet tubes. Then subtract the inlet tube temperature reading from the outlet tube temperature reading.

(9) See the Low Charge Determination chart to determine the additional charge required. If the measured temperature differential is higher than 22° C to 26° C (40° F to 47° F), add 0.4 kilograms (14 ounces) of refrigerant.

(10) Allow three to five minutes for the refrigerant system to stabilize, then take a second set of thermocouple measurements. Record the temperature difference and see the Low Charge Determination chart (Fig. 19) to determine if an additional charge is required.

(11) Record the compressor discharge pressure. If the reading is higher than the pressure shown in the Compressor Discharge Pressure chart (Fig. 20), the system could be overcharged. If the reading is equal to, or lower, than the pressure shown in the chart, continue with this procedure.

(12) **EXAMPLE:** The ambient temperature is 21° C (70° F). The evaporator inlet tube temperature is 12° C (54° F) and the evaporator outlet tube temperature is 10° C (50° F). Subtract the inlet tube temperature from the outlet tube temperature. The difference is -2° C (-4° F). With a -2° C (-4° F) temperature differential at 21° C (70° F) ambient temperature, the system is fully charged.

(13) Add enough refrigerant to bring the refrigerant system up to a full charge.

(14) Remove the jumper wire from the low pressure cycling clutch switch wire harness connector and plug the connector back into the switch.

REFRIGERANT OIL LEVEL

When an air conditioning system is assembled at the factory, all components except the compressor are refrigerant oil free. After the refrigerant system has been charged and operated, the refrigerant oil in the compressor is dispersed throughout the refrigerant system. The accumulator, evaporator, condenser, and compressor will each retain a significant amount of the needed refrigerant oil.

It is important to have the correct amount of oil in the refrigerant system. This ensures proper lubrication of the compressor. Too little oil will result in damage to the compressor. Too much oil will reduce the cooling capacity of the air conditioning system.

It will not be necessary to check the oil level in the compressor or to add oil, unless there has been an oil loss. An oil loss may occur due to a rupture or leak from a refrigerant line, a connector fitting, a component, or a component seal. If a leak occurs, add 30

SERVICE PROCEDURES (Continued)

Open the windows and/or doors of the passenger compartment. Set the air conditioning controls to A/C, PANEL, RECIRC (temperature knob on full cool) and blower speed on HIGH. Set the engine speed at 1,000 RPM.

Evaporator Outlet and Inlet Temperature Differential					
<ul style="list-style-type: none"> • If Outlet is WARMER than Inlet, temperature differential is plus (+). • If Outlet is COLDER than Inlet, temperature differential is minus (-). <p>See the example in the Refrigerant Charge Check (Alternative Method).</p>					
Added Amount of R134a to Properly Charge A/C System	Ambient Temperature				
	21°C (70°F)	27°C (80°F)	32°C (90°F)	38°C (100°F)	43°C (110°F)
	Differential Temperature				
0.90 lbs. (14 oz.)	+22°C (+40°F)	+23°C (+42°F)	+24°C (+43°F)	+25°C (+45°F)	+26°C (+47°F)
0.75 lbs. (12 oz.)	+12°C (+22°F)	+12°C (+23°F)	+13°C (+24°F)	+15°C (+26°F)	+16°C (+28°F)
0.60 lbs. (10 oz.)	+4°C (+8°F)	+5°C (+9°F)	+6°C (+10°F)	+7°C (+12°F)	+8°C (+13°F)
0.50 lbs. (8 oz.)	0°C (0°F)	+0°C (+1°F)	+1°C (+2°F)	+2°C (+3°F)	+3°C (+4°F)
0.40 lbs. (6 oz.)	-1°C (-2°F)	-1°C (-1°F)	+0°C (-0°F)	0°C (0°F)	0°C (0°F)
Recommended Charge	-2 to -6°C (-3 to -10°F)				

Note: A temperature differential of -2°C to -6°C (-3°F to -10°F) indicates an acceptable charge.

J9324-86

Fig. 19 Low Charge Determination

Ambient Temperature	16°C (60°F)	21°C (70°F)	27°C (80°F)	32°C (90°F)	38°C (100°F)	43°C (110°F)
Compressor Discharge Pressure	1515 kPa (220 psi)	1655 kPa (240 psi)	1790 kPa (260 psi)	2070 kPa (300 psi)	2345 kPa (340 psi)	2690 kPa (390 psi)

J9324-40

Fig. 20 Compressor Discharge Pressure

milliliters (1 fluid ounce) of refrigerant oil to the refrigerant system after the repair has been made. Refrigerant oil loss will be evident at the leak point by the presence of a wet, shiny surface around the leak.

Refrigerant oil must be added when a accumulator, evaporator coil, or condenser are replaced. See the Refrigerant Oil Capacities chart. When a compressor is replaced, the refrigerant oil must be drained from the old compressor and measured. Drain all of the refrigerant oil from the new compressor, then fill the new compressor with the same amount of refrigerant oil that was drained out of the old compressor.

SERVICE PROCEDURES (Continued)

Refrigerant Oil Capacities		
Component	ml	fl oz
A/C System	220	7.44
Accumulator	120	4
Condenser	30	1
Evaporator	60	2
Compressor	drain and measure the oil from the old compressor - see text.	

REMOVAL AND INSTALLATION

AMBIENT TEMPERATURE SENSOR

- (1) Disconnect and isolate the battery negative cable.
- (2) Remove the radiator grille from the vehicle. Refer to Group 23 - Body for the procedures.
- (3) Locate the ambient temperature sensor, on the radiator support behind the grille (Fig. 21).

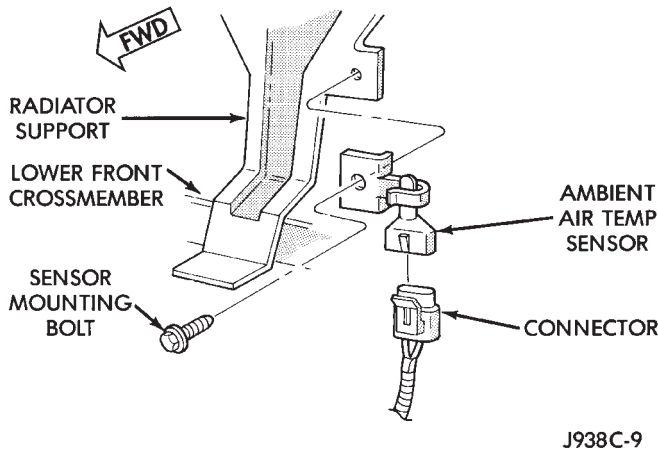


Fig. 21 Ambient Temperature Sensor Remove/Install

- (4) Unplug the ambient temperature sensor wire harness connector.
- (5) Remove the screw that secures the ambient temperature sensor to the radiator support.
- (6) Remove the ambient temperature sensor from the vehicle.
- (7) Reverse the removal procedures to install. Tighten the ambient temperature sensor mounting screw to 2.2 N·m (20 in. lbs.).

REFRIGERANT LINE COUPLER

WARNING: REVIEW THE WARNINGS AND CAUTIONS IN THE FRONT OF THIS GROUP BEFORE PERFORMING THE FOLLOWING OPERATION.

REMOVAL

- (1) Recover the refrigerant from the refrigerant system. See Refrigerant Recovery in this group for the procedures.
- (2) Remove the secondary clip from the spring-lock coupler.
- (3) Fit the proper size A/C line disconnect tool (Special Tool Kit 7193) over the spring-lock coupler cage (Fig. 22).

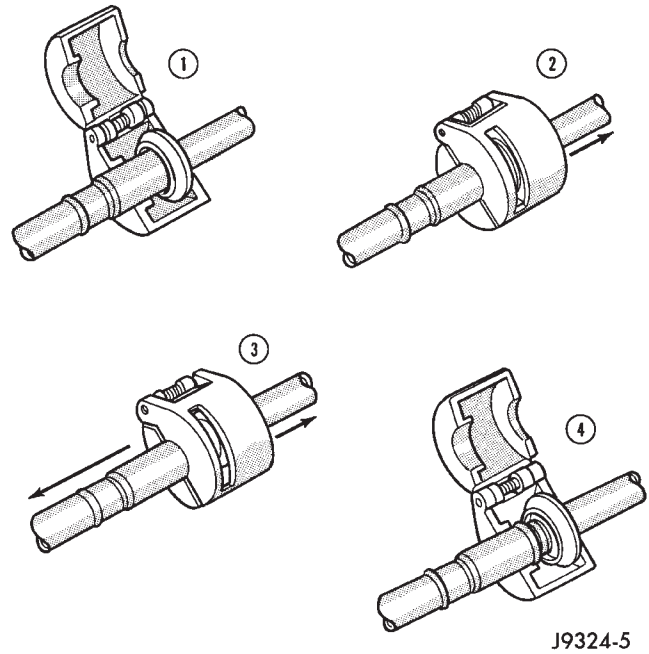


Fig. 22 Refrigerant Line Spring-Lock Coupler Disconnect

- (4) Close the two halves of the A/C line disconnect tool around the spring-lock coupler.
- (5) Push the A/C line disconnect tool into the open side of the coupler cage to expand the garter spring. Once the garter spring is expanded and while still pushing the disconnect tool into the open side of the coupler cage, pull on the refrigerant line attached to the female half of the coupler fitting until the flange on the female fitting is separated from the garter spring and cage on the male fitting within the disconnect tool.

NOTE: The garter spring may not release if the A/C line disconnect tool is cocked while pushing it into the coupler cage opening.

- (6) Open and remove the A/C line disconnect tool from the disconnected spring-lock coupler.
- (7) Complete the separation of the two halves of the coupler fitting.

REMOVAL AND INSTALLATION (Continued)

INSTALLATION

(1) Check to ensure that the garter spring is located within the cage of the male coupler fitting, and that the garter spring is not damaged.

(a) If the garter spring is missing, install a new spring by pushing it into the coupler cage opening.

(b) If the garter spring is damaged, remove it from the coupler cage with a small wire hook (DO NOT use a screwdriver) and install a new garter spring.

(2) Clean any dirt or foreign material from both halves of the coupler fitting.

(3) Install new O-rings on the male half of the coupler fitting.

CAUTION: Use only the specified O-rings as they are made of a special material for the R-134a system. The use of any other O-rings may allow the connection to leak intermittently during vehicle operation.

(4) Lubricate the male fitting and O-rings, and the inside of the female fitting with clean R-134a refrigerant oil. Use only refrigerant oil of the type recommended for the compressor in the vehicle.

(5) Fit the female half of the coupler fitting over the male half of the fitting.

(6) Push together firmly on the two halves of the coupler fitting until the garter spring in the cage on the male half of the fitting snaps over the flanged end on the female half of the fitting.

(7) Ensure that the spring-lock coupler is fully engaged by trying to separate the two coupler halves. This is done by pulling the refrigerant lines on either side of the coupler away from each other.

(8) Reinstall the secondary clip over the spring-lock coupler cage.

HIGH PRESSURE CUT-OFF SWITCH

REMOVAL

(1) Disconnect and isolate the battery negative cable.

(2) Unplug the wire harness connector from the high pressure cut-off switch, which is mounted to a fitting on the discharge line between the compressor and the condenser inlet (Fig. 23).

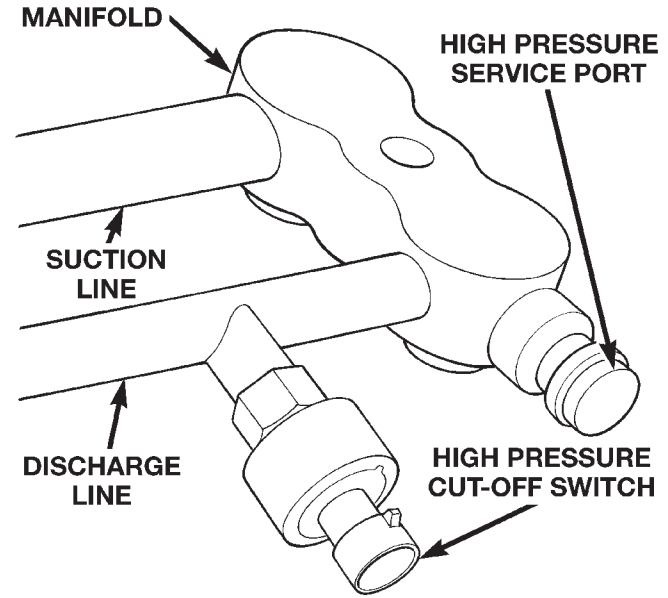
(3) Unscrew the high pressure cut-off switch from the discharge line fitting.

(4) Remove the high pressure cut-off switch from the vehicle.

(5) Remove the O-ring seal from the discharge line fitting and discard.

INSTALLATION

(1) Lubricate a new O-ring seal with clean refrigerant oil and install it on the discharge line fitting.



80add30e

Fig. 23 High Pressure Cut-Off Switch Remove/Install - Typical

Use only the specified O-rings as they are made of a special material for the R-134a system. Use only refrigerant oil of the type recommended for the compressor in the vehicle.

(2) Install and tighten the high pressure cut-off switch on the discharge line fitting.

(3) Plug the wire harness connector into the high pressure cut-off switch.

(4) Connect the battery negative cable.

DISCHARGE LINE

Any kinks or sharp bends in the refrigerant plumbing will reduce the capacity of the entire air conditioning system. Kinks and sharp bends reduce the flow of refrigerant in the system. A good rule for the flexible hose refrigerant lines is to keep the radius of all bends at least ten times the diameter of the hose. In addition, the flexible hose refrigerant lines should be routed so they are at least 80 millimeters (3 inches) from the exhaust manifold.

High pressures are produced in the refrigerant system when the air conditioning compressor is operating. Extreme care must be exercised to make sure that each of the refrigerant system connections is pressure-tight and leak free. It is a good practice to inspect all flexible hose refrigerant lines at least once a year to make sure they are in good condition and properly routed.

WARNING: REVIEW THE WARNINGS AND CAUTIONS IN THE FRONT OF THIS GROUP BEFORE PERFORMING THE FOLLOWING OPERATION.

REMOVAL AND INSTALLATION (Continued)**REMOVAL**

- (1) Disconnect and isolate the battery negative cable.
- (2) Recover the refrigerant from the refrigerant system. See Refrigerant Recovery in this group for the procedures.
- (3) Remove the high pressure cut-off switch. See High Pressure Cut-Off Switch in this group for the procedures.
- (4) Disconnect the discharge line refrigerant line fitting from the condenser inlet tube. See Refrigerant Line Coupler in this group for the procedures. Install plugs in, or tape over all of the opened refrigerant line fittings.
- (5) Remove the screw that secures the discharge line block fitting to the manifold on the compressor. Install plugs in, or tape over all of the opened refrigerant line fittings.
- (6) Remove the discharge line assembly from the vehicle.

INSTALLATION

- (1) Remove the tape or plugs from the discharge line block fitting and the manifold on the compressor. Install the discharge line block fitting to the manifold on the compressor. Tighten the mounting screw to 28 N·m (250 in. lbs.).
- (2) Remove the tape or plugs from the refrigerant line fittings on the discharge line and the condenser inlet tube. Connect the discharge line refrigerant line coupler to the condenser inlet tube. See Refrigerant Line Coupler in this group for the procedures.
- (3) Install the high pressure cut-off switch. See High Pressure Cut-Off Switch in this group for the procedures.
- (4) Connect the battery negative cable.
- (5) Evacuate the refrigerant system. See Refrigerant System Evacuate in this group for the procedures.
- (6) Charge the refrigerant system. See Refrigerant System Charge in this group for the procedures.

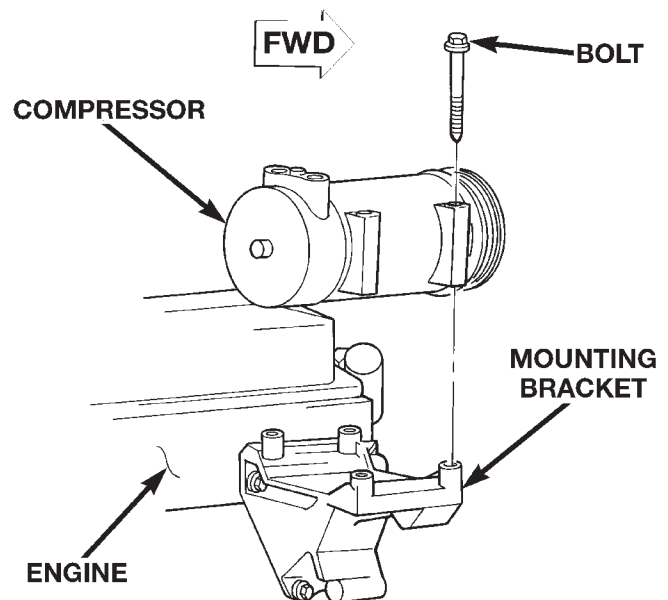
COMPRESSOR

The compressor may be removed and repositioned without disconnecting the refrigerant lines or discharging the refrigerant system. Discharging is not necessary if servicing the compressor clutch or clutch coil, the engine, the cylinder head, or the generator.

WARNING: REVIEW THE WARNINGS AND CAUTIONS IN THE FRONT OF THIS GROUP BEFORE PERFORMING THE FOLLOWING OPERATION.

REMOVAL

- (1) Recover the refrigerant from the refrigerant system. See Refrigerant Recovery in this group for the procedures.
- (2) Disconnect and isolate the battery negative cable.
- (3) Remove the serpentine drive belt. Refer to Group 7 - Cooling System for the procedures.
- (4) Unplug the compressor clutch coil wire harness connector.
- (5) Remove the screws that secure the suction line and discharge line block fittings to the manifold on the compressor. Install plugs in, or tape over all of the opened refrigerant fittings.
- (6) Remove the screws that secure the compressor to the mounting bracket (Fig. 24) or (Fig. 25).



80abd2a8

Fig. 24 Compressor Remove/Install - 6 Cylinder Engine

- (7) Remove the compressor from the mounting bracket.

INSTALLATION

NOTE: If a replacement compressor is being installed, be certain to check the refrigerant oil level. See Refrigerant Oil Level in this group for the procedures. Use only refrigerant oil of the type recommended for the compressor in the vehicle.

- (1) Install the compressor to the mounting bracket. Tighten the mounting screws to 28 N·m (21 ft. lbs.).
- (2) Remove the tape or plugs from all of the opened refrigerant line fittings. Install the suction line and discharge line block fittings to the manifold

REMOVAL AND INSTALLATION (Continued)

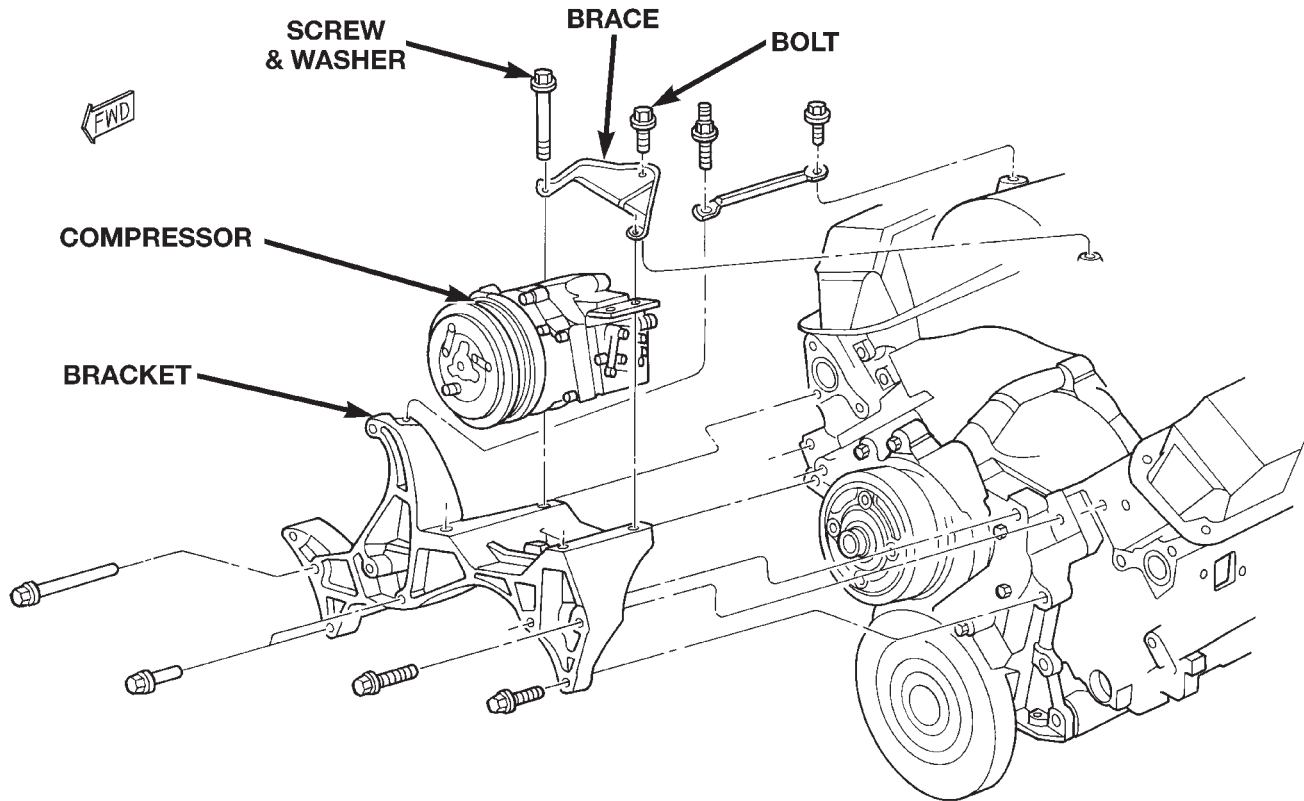


Fig. 25 Compressor Remove/Install - 8 Cylinder Engine

80a89405

on the compressor. Tighten the mounting screws to 28 N·m (250 in. lbs.).

(3) Install the serpentine drive belt. Refer to Group 7 - Cooling System for the procedures.

(4) Plug in the compressor clutch coil wire harness connector.

(5) Connect the battery negative cable.

(6) Evacuate the refrigerant system. See Refrigerant System Evacuate in this group for the procedures.

(7) Charge the refrigerant system. See Refrigerant System Charge in this group for the procedures.

HIGH PRESSURE RELIEF VALVE

WARNING: REVIEW THE WARNINGS AND CAUTIONS IN THE FRONT OF THIS GROUP BEFORE PERFORMING THE FOLLOWING OPERATION.

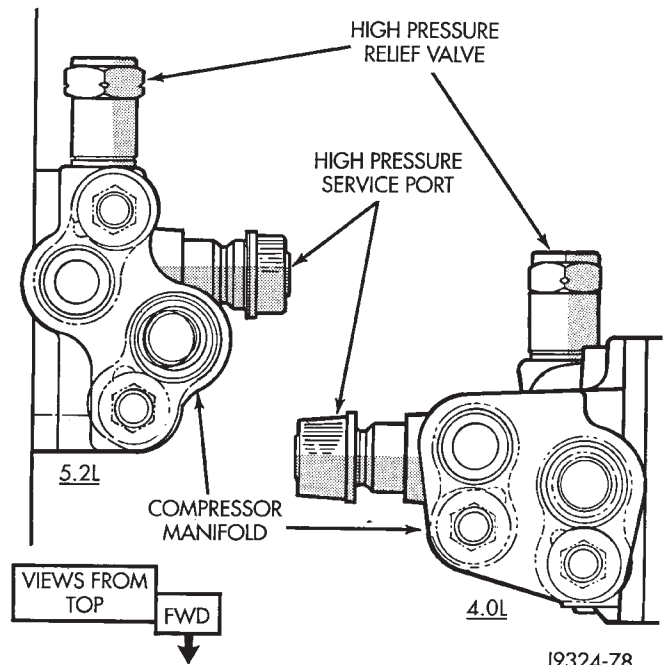
REMOVAL

(1) Disconnect and isolate the battery negative cable.

(2) Recover the refrigerant from the refrigerant system. See Refrigerant Recovery in this group for the procedures.

(3) Turn the relief valve counterclockwise to remove it from the compressor manifold (Fig. 26).

Install a plug in, or tape over the opened relief valve fitting on the compressor manifold.



J9324-78

Fig. 26 High Pressure Relief Valve - Typical

REMOVAL AND INSTALLATION (Continued)**INSTALLATION**

- (1) Remove the tape or plug from the relief valve fitting on the compressor manifold.
- (2) Install the high pressure relief valve in the compressor manifold fitting.
- (3) Connect the battery negative cable.
- (4) Evacuate the refrigerant system. See Refrigerant System Evacuate in this group for the procedures.
- (5) Charge the refrigerant system. See Refrigerant System Charge in this group for the procedures.

COMPRESSOR CLUTCH

The refrigerant system can remain fully-charged during compressor clutch, pulley, or coil replacement. The compressor clutch can be serviced in the vehicle.

REMOVAL

- (1) Disconnect and isolate the battery negative cable.
- (2) Remove the serpentine drive belt. Refer to Group 7 - Cooling System for the procedures.
- (3) Remove the bolt that secures the compressor clutch to the compressor shaft (Fig. 27). A band-type oil filter wrench may be used to secure the clutch during bolt removal.

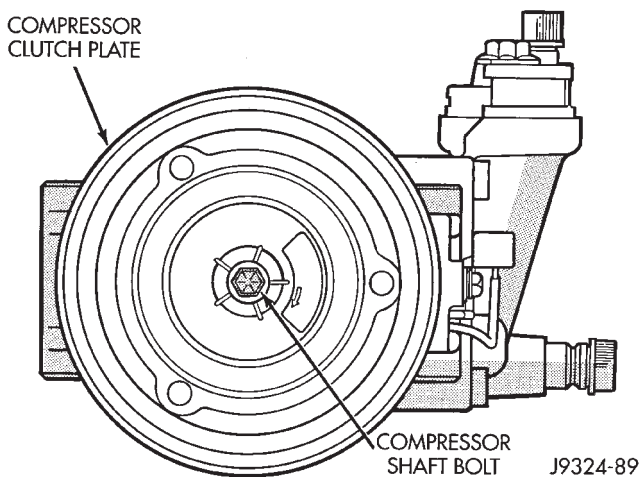


Fig. 27 Compressor Shaft Bolt

- (4) Tap the clutch plate with a plastic mallet to release it from the splines on the compressor shaft. Remove the clutch plate and shim(s) from the compressor shaft (Fig. 28).

CAUTION: Do not pry between the clutch plate assembly and the pulley to remove it from the compressor shaft. Prying may damage the clutch plate assembly.

- (5) Remove the external snap ring that secures the compressor clutch pulley to the nose of the compressor front housing with snap ring pliers (Special Tool

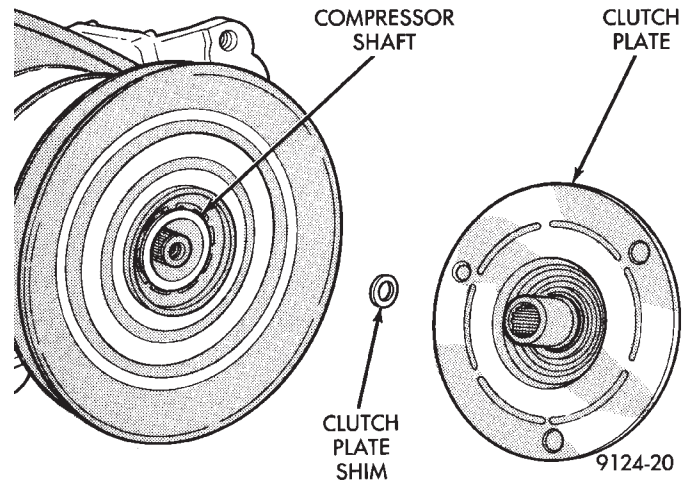


Fig. 28 Clutch Plate and Shim

- C-4574) and slide the pulley assembly off of the compressor (Fig. 29).

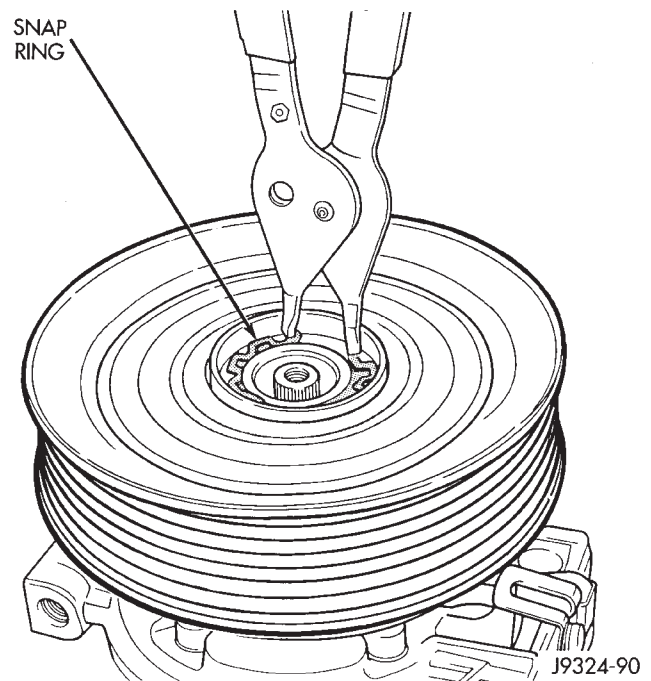


Fig. 29 Pulley Snap Ring Remove/Install

- (6) Remove the screw and retainer from the clutch coil lead wire harness on the compressor front housing.

- (7) Remove the external snap ring that secures the compressor clutch coil to the nose of the compressor front housing with snap ring pliers and slide the coil assembly off of the compressor (Fig. 30).

INSPECTION

Examine the friction surfaces of the clutch pulley and the clutch plate for wear. The pulley and plate should be replaced if there is excessive wear or scoring.

REMOVAL AND INSTALLATION (Continued)

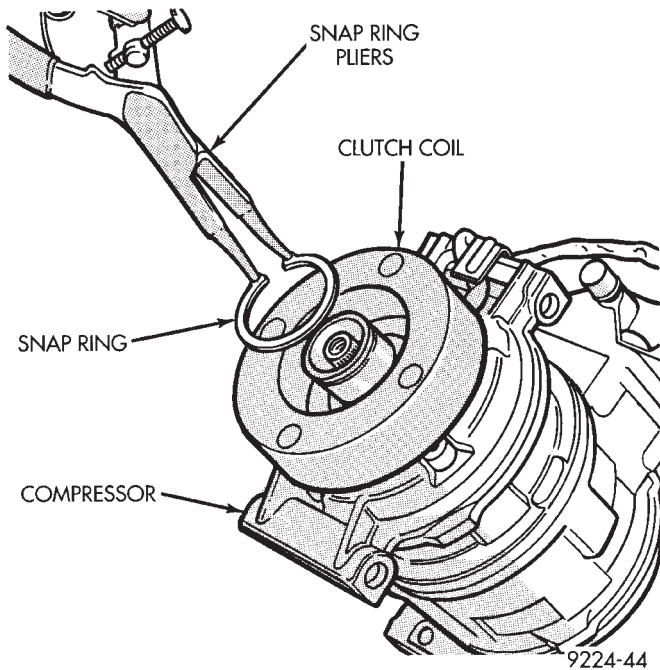


Fig. 30 Clutch Coil Snap Ring Remove/Install

If the friction surfaces are oily, inspect the shaft and nose area of the compressor for refrigerant oil. Remove the felt wick from around the shaft inside the nose of the compressor front housing. If the felt is saturated with refrigerant oil, the compressor shaft seal is leaking and the compressor must be replaced.

Check the clutch pulley bearing for roughness or excessive leakage of grease. Replace the bearing, if required.

INSTALLATION

(1) Align the dowel pin on the back of the clutch field coil with the hole in the compressor front housing and press the field coil into place over the nose of the compressor.

(2) Install the clutch coil lead wire harness retaining clip on the compressor front housing and tighten the retaining screw.

(3) Install the clutch field coil and snap ring with snap ring pliers (Special Tool C-4574). The bevel side of the snap ring must be facing outward. Also, both eyelets of the snap ring must be to the right or left of the pin on the compressor. Press in on the snap ring to be certain that it is properly seated in the groove.

CAUTION: If the snap ring is not fully seated in the groove it will vibrate out, resulting in a clutch failure and severe damage to the front housing of the compressor.

(4) Install the pulley assembly onto the compressor. If necessary, place a block of wood on the friction surface and tap gently with a hammer (Fig. 31).

CAUTION: Do not mar the pulley friction surface.

(5) Install the pulley assembly retaining snap ring (bevel side outward) with snap ring pliers (Special Tool C-4574). Press in on the snap ring to be certain that it is properly seated in the groove.

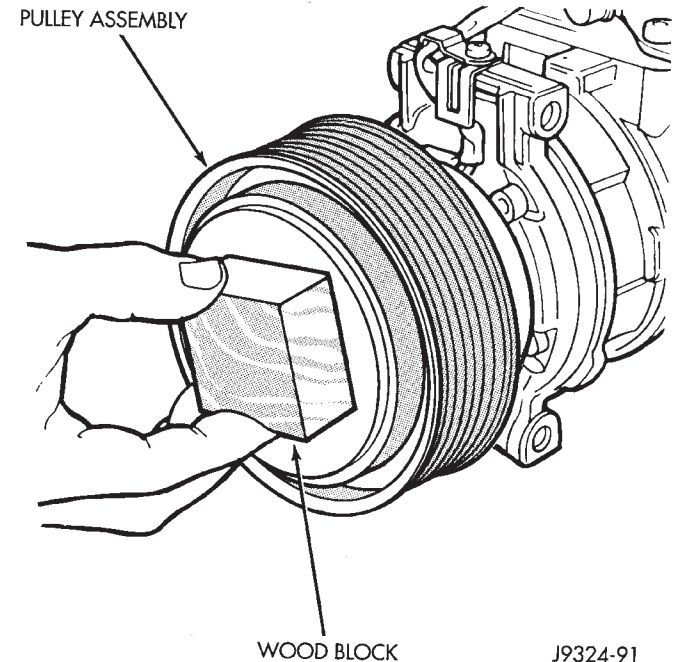


Fig. 31 Pulley Assembly Install

(6) If the original clutch plate assembly and pulley assembly are to be reused, the old shim(s) can be used. If not, place a stack of shim(s) equal to the old shim(s) on the shaft against the shoulder.

(7) Install the clutch plate assembly onto the shaft.

(8) With the clutch plate assembly tight against the shim(s), measure the air gap between the clutch plate and the pulley face with feeler gauges. The air gap should be between 0.35 to 0.65 millimeter (0.014 to 0.026 inch). If the proper air gap is not obtained, add or subtract shims as needed until the desired air gap is obtained.

(9) Install the compressor shaft bolt. Tighten the bolt to 13 N·m (115 in. lbs.).

NOTE: The shims may compress after tightening the shaft bolt. Check the air gap in four or more places to verify the air gap is still correct. Spin the pulley before performing a final check of the air gap.

(10) Reverse the remaining removal procedures to complete the installation.

CLUTCH BREAK-IN

After a new compressor clutch has been installed, cycle the compressor clutch approximately twenty

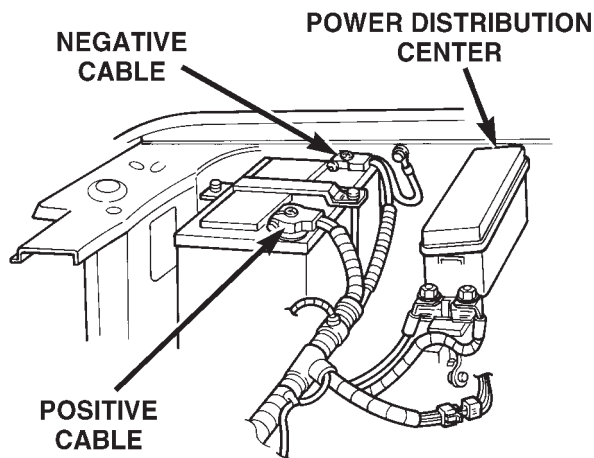
REMOVAL AND INSTALLATION (Continued)

times (five seconds on, then five seconds off). During this procedure, set the heater-A/C control in the Recirculation Mode, the A/C button in the on position, the blower motor switch in the highest speed position, and the engine speed at 1500 to 2000 rpm. This procedure (burnishing) will seat the opposing friction surfaces and provide a higher compressor clutch torque capability.

COMPRESSOR CLUTCH RELAY

(1) Disconnect and isolate the battery negative cable.

(2) Remove the cover from the Power Distribution Center (PDC) (Fig. 32).



80a7233a

Fig. 32 Power Distribution Center

(3) Refer to the label on the PDC for compressor clutch relay identification and location.

(4) Unplug the compressor clutch relay from the PDC.

(5) Install the compressor clutch relay by aligning the relay terminals with the cavities in the PDC and pushing the relay firmly into place.

(6) Install the PDC cover.

(7) Connect the battery negative cable.

(8) Test the relay operation.

LIQUID LINE

Any kinks or sharp bends in the refrigerant plumbing will reduce the capacity of the entire air conditioning system. Kinks and sharp bends reduce the flow of refrigerant in the system. High pressures are produced in the refrigerant system when the air conditioning compressor is operating. Extreme care must be exercised to make sure that each of the refrigerant system connections is pressure-tight and leak free.

WARNING: REVIEW THE WARNINGS AND CAUTIONS IN THE FRONT OF THIS GROUP BEFORE PERFORMING THE FOLLOWING OPERATION.

REMOVAL

(1) Disconnect and isolate the battery negative cable.

(2) Recover the refrigerant from the refrigerant system. See Refrigerant Recovery in this group for the procedures.

(3) Unsnap the plastic retainer clips that secure the liquid line to the inner fender shield and the dash panel in the engine compartment.

(4) Disengage the liquid line from the plastic retainer clips.

(5) Disconnect the liquid line refrigerant line fitting from the evaporator inlet tube. See Refrigerant Line Coupler in this group for the procedures. Install plugs in, or tape over all of the opened refrigerant line fittings.

(6) Disconnect the liquid line from the condenser outlet tube refrigerant line fitting. See Refrigerant Line Coupler in this group for the procedures. Install plugs in, or tape over all of the opened refrigerant line fittings.

(7) Remove the liquid line from the plastic clip that secures it to the right inner fender shield.

(8) Remove the liquid line from the vehicle.

INSTALLATION

(1) Remove the tape or plugs from the refrigerant line fittings on the condenser outlet tube and the condenser end of the liquid line. Connect the liquid line to the condenser outlet tube refrigerant line coupler. See Refrigerant Line Coupler in this group for the procedures.

(2) Remove the tape or plugs from the refrigerant line fittings on the evaporator end of the liquid line and from the evaporator inlet tube. Connect the liquid line refrigerant line coupler to the evaporator inlet tube. See Refrigerant Line Coupler in this group for the procedures.

(3) Install the liquid line into the plastic retainer clips that secure it to the inner fender shield and the dash panel and snap the retainer clips closed.

(4) Connect the battery negative cable.

(5) Evacuate the refrigerant system. See Refrigerant System Evacuate in this group for the procedures.

(6) Charge the refrigerant system. See Refrigerant System Charge in this group for the procedures.

FIXED ORIFICE TUBE

The fixed orifice tube is located in the liquid line near the condenser. If the fixed orifice tube is faulty or plugged, the liquid line unit must be replaced. See Liquid Line in this group for the service procedures.

REMOVAL AND INSTALLATION (Continued)

LOW PRESSURE CYCLING CLUTCH SWITCH

REMOVAL

- (1) Disconnect and isolate the battery negative cable.
- (2) Unplug the wire harness connector from the low pressure cycling clutch switch on the top of the accumulator.
- (3) Unscrew the low pressure cycling clutch switch from the fitting on the top of the accumulator.
- (4) Remove the O-ring seal from the accumulator fitting and discard.

INSTALLATION

- (1) Lubricate a new O-ring seal with clean refrigerant oil and install it on the accumulator fitting. Use only the specified O-rings as they are made of a special material for the R-134a system. Use only refrigerant oil of the type recommended for the compressor in the vehicle.
- (2) Install and tighten the low pressure cycling clutch switch on the accumulator fitting. The switch should be hand-tightened onto the accumulator fitting.
- (3) Plug the wire harness connector into the low pressure cycling clutch switch.
- (4) Connect the battery negative cable.

ACCUMULATOR

WARNING: REVIEW THE WARNINGS AND CAUTIONS IN THE FRONT OF THIS GROUP BEFORE PERFORMING THE FOLLOWING OPERATION.

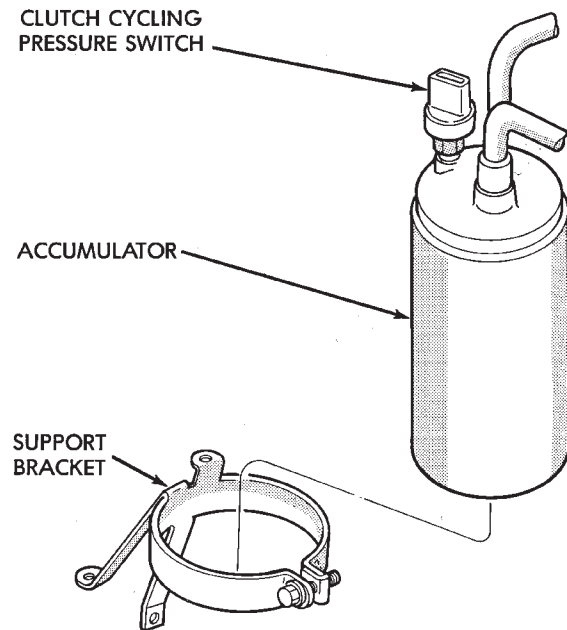
The suction lines from the evaporator outlet tube to the accumulator, and from the accumulator to the suction port of the compressor manifold are integral to the accumulator. If either suction line or the accumulator is faulty or damaged, the accumulator assembly must be replaced.

Any kinks or sharp bends in the refrigerant plumbing will reduce the capacity of the entire air conditioning system. Kinks and sharp bends reduce the flow of refrigerant in the system. A good rule for the flexible hose refrigerant lines is to keep the radius of all bends at least ten times the diameter of the hose. In addition, the flexible hose refrigerant lines should be routed so they are at least 80 millimeters (3 inches) from the exhaust manifold.

High pressures are produced in the refrigerant system when the air conditioning compressor is operating. Extreme care must be exercised to make sure that each of the refrigerant system connections is pressure-tight and leak free. It is a good practice to inspect all flexible hose refrigerant lines at least once a year to make sure they are in good condition and properly routed.

REMOVAL

- (1) Disconnect and isolate the battery negative cable.
- (2) Remove the low pressure cycling clutch switch from the accumulator. See Low Pressure Cycling Clutch Switch in this group for the procedures.
- (3) Recover the refrigerant from the refrigerant system. See Refrigerant Recovery in this group for the procedures.
- (4) Disconnect the suction line refrigerant line fitting from the evaporator outlet tube. See Refrigerant Line Coupler in this group for the procedures. Install plugs in, or tape over all of the opened refrigerant line fittings.
- (5) Remove the screw that secures the suction line block fitting to the manifold on the compressor. Install plugs in, or tape over all of the opened refrigerant line fittings.
- (6) Loosen the screw that clamps the band of the accumulator support bracket around the accumulator (Fig. 33).



J9324-34

Fig. 33 Accumulator and Support Bracket

- (7) Remove the accumulator from the support bracket.

INSTALLATION

- (1) Install the accumulator through the band of the support bracket. Be certain that the index tab on the side of the accumulator is aligned with the notch in the support bracket band.
- (2) Tighten the clamp screw in the support bracket band to 12 N·m (105 in. lbs.).
- (3) Remove the tape or plugs from the suction line block fitting and the manifold on the compressor.

REMOVAL AND INSTALLATION (Continued)

Install the suction line block fitting to the manifold on the compressor. Tighten the mounting screw to 28 N·m (250 in. lbs.).

(4) Remove the tape or plugs from the refrigerant line fittings on the suction line and the evaporator outlet tube. Connect the suction line refrigerant line coupler to the evaporator outlet tube. See Refrigerant Line Coupler in this group for the procedures.

(5) Install the low pressure cycling clutch switch onto the accumulator fitting. See Low Pressure Cycling Clutch Switch in this group for the procedures.

(6) Connect the battery negative cable.

(7) Evacuate the refrigerant system. See Refrigerant System Evacuate in this group for the procedures.

(8) Charge the refrigerant system. See Refrigerant System Charge in this group for the procedures.

NOTE: If the accumulator is replaced, add 120 milliliters (4 fluid ounces) of refrigerant oil to the refrigerant system. Use only refrigerant oil of the type recommended for the compressor in the vehicle.

CONDENSER

WARNING: REVIEW THE WARNINGS AND CAUTIONS IN THE FRONT OF THIS GROUP BEFORE PERFORMING THE FOLLOWING OPERATION.

CAUTION: Before removing the condenser, note the location of each of the radiator and condenser air seals. These seals are used to direct air through the condenser and radiator. The air seals must be reinstalled in their proper locations in order for the air conditioning and engine cooling systems to perform as designed (Fig. 34).

REMOVAL

(1) Disconnect and isolate the battery negative cable.

(2) Recover the refrigerant from the refrigerant system. See Refrigerant Recovery in this group for the procedures.

(3) Remove the radiator grille panel from the vehicle. Refer to Group 23 - Body for the procedures.

(4) Remove the upper bolts from the two radiator braces (Fig. 35).

(5) Remove the two nuts that secure the radiator to the upper crossmember (Fig. 36).

REMOVAL AND INSTALLATION (Continued)

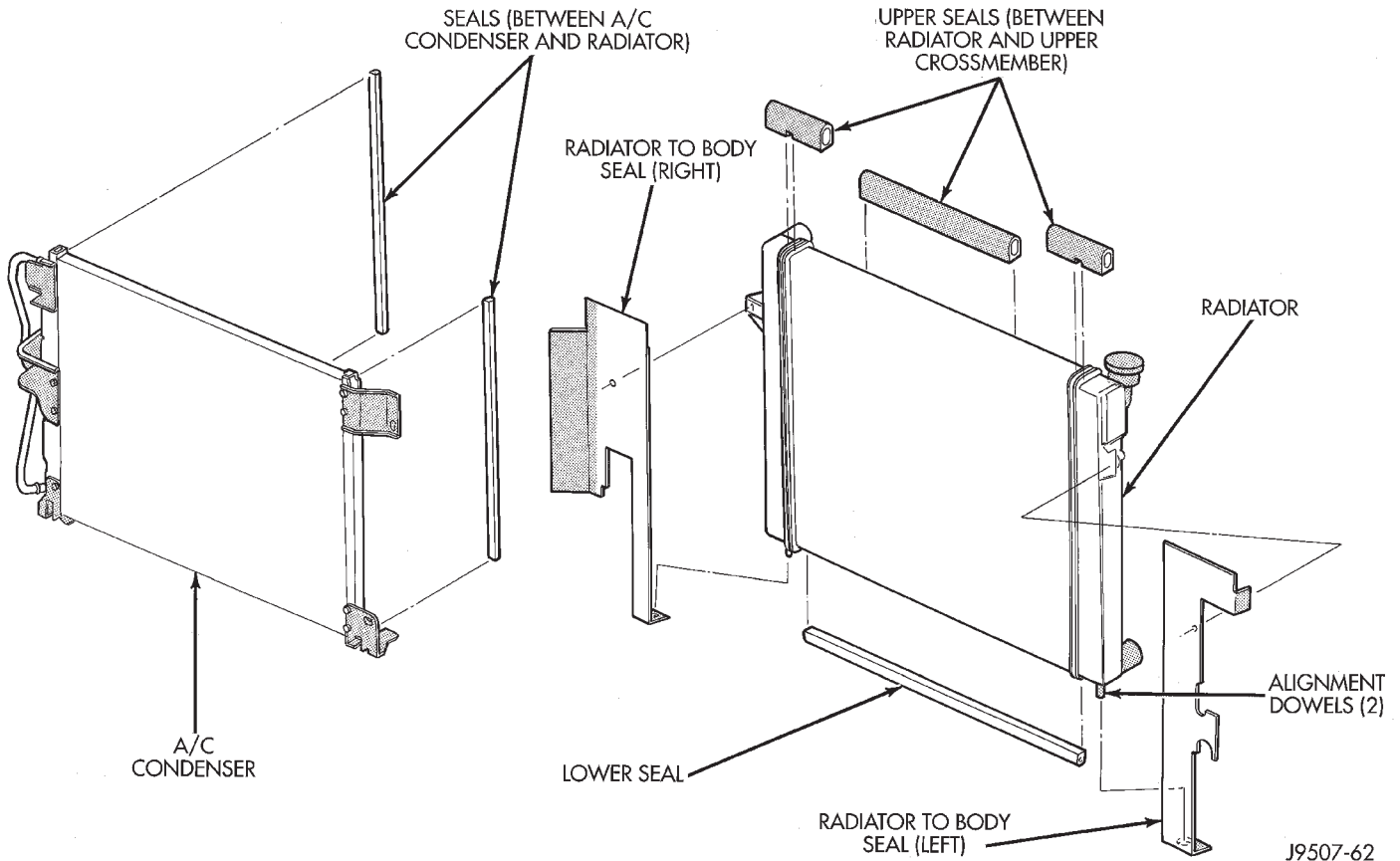


Fig. 34 Air Seals

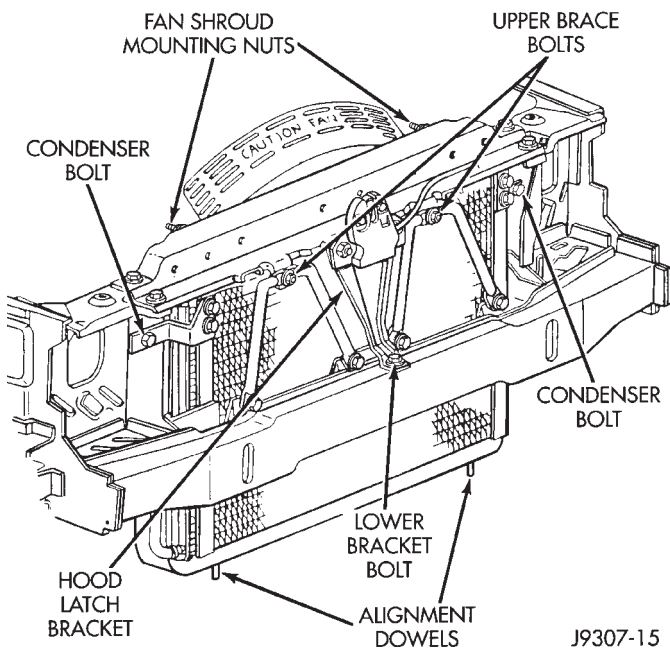


Fig. 35 Condenser Mounting

(6) Reach through the grille opening and remove the bolt that secures the lower hood latch support to the lower front crossmember.

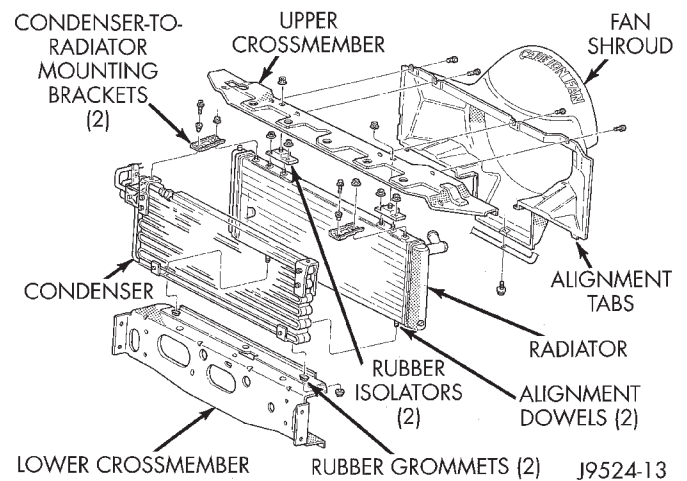


Fig. 36 Radiator Upper Crossmember - Typical

(7) The radiator upper crossmember can be adjusted left or right through the use of its slotted mounting holes. Before removal, mark the original position of the crossmember.

(8) Remove the remaining bolts that secure the radiator upper crossmember to the body. Do not remove the hood latch or hood latch cable from the crossmember. Lift the crossmember straight up and lay it to the side.

REMOVAL AND INSTALLATION (Continued)

(9) Disconnect the discharge line and liquid line refrigerant line fittings from the condenser. See Refrigerant Line Coupler in this group for the procedures. Install plugs in, or tape over all of the opened refrigerant line fittings.

(10) Remove the four bolts that secure the lower condenser.

(11) Remove the two bolts that secure the upper condenser.

(12) Carefully lift the condenser out of the vehicle.

INSTALLATION

(1) Carefully position the condenser in the vehicle.

(2) Install and tighten the two bolts that secure the upper condenser.

(3) Install and tighten the four bolts that secure the lower condenser.

(4) Remove the tape or plugs from the refrigerant line fittings on the discharge line, liquid line and the condenser. Connect both of the refrigerant line couplers to the condenser. See Refrigerant Line Coupler in this group for the procedures.

(5) Align the radiator upper crossmember with the scribe marks. Install and tighten the bolts that secure the radiator upper crossmember to the body.

(6) Install and tighten the nuts that secure the radiator to the upper crossmember.

(7) Reach through the grille opening to install and tighten the bolt that secures the lower hood latch support to the lower front crossmember.

(8) Install and tighten the two bolts that secure the radiator braces to the upper radiator crossmember.

(9) Install the radiator grille panel in the vehicle. Refer to Group 23 - Body for the procedures.

(10) Connect the battery negative cable.

(11) Evacuate the refrigerant system. See Refrigerant System Evacuate in this group for the procedures.

(12) Charge the refrigerant system. See Refrigerant System Charge in this group for the procedures.

NOTE: If the condenser is replaced, add 30 milliliters (1 fluid ounce) of refrigerant oil to the refrigerant system. Use only refrigerant oil of the type recommended for the compressor in the vehicle.

VACUUM CHECK VALVE

(1) Unplug the heater-A/C vacuum supply line connector at the vacuum check valve near the engine intake manifold vacuum adapter fitting.

(2) Note the orientation of the check valve in the vacuum supply line for correct installation.

(3) Unplug the vacuum check valve from the vacuum supply line fittings.

(4) Reverse the removal procedures to install.

VACUUM RESERVOIR

(1) Remove the battery from the battery tray. Refer to Group 8A - Battery for the procedures.

(2) Remove the five screws that secure the battery tray to the vehicle.

(3) Pull up the battery tray far enough to access and unplug the vacuum harness connector from the reservoir (Fig. 37).

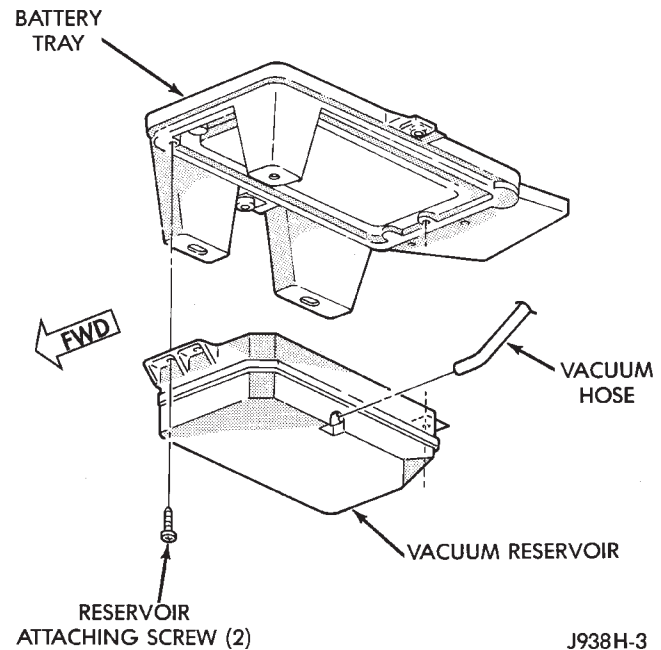


Fig. 37 Vacuum Reservoir Remove/Install

(4) Remove the battery tray and vacuum reservoir from the vehicle as a unit.

(5) Remove the two screws that secure the vacuum reservoir to the underside of the battery tray.

(6) Remove the vacuum reservoir from the battery tray.

(7) Reverse the removal procedures to install. Tighten the reservoir mounting screws to 1 N·m (10 in. lbs.). Tighten the battery tray mounting screws to 8 N·m (70 in. lbs.).

HEATER-A/C CONTROL

WARNING: ON VEHICLES EQUIPPED WITH AIRBAGS, REFER TO GROUP 8M - PASSIVE RESTRAINT SYSTEMS BEFORE ATTEMPTING ANY STEERING WHEEL, STEERING COLUMN, OR INSTRUMENT PANEL COMPONENT DIAGNOSIS OR SERVICE. FAILURE TO TAKE THE PROPER PRECAUTIONS COULD RESULT IN ACCIDENTAL AIRBAG DEPLOYMENT AND POSSIBLE PERSONAL INJURY.

REMOVAL AND INSTALLATION (Continued)

REMOVAL

- (1) Disconnect and isolate the battery negative cable.
- (2) Remove the inboard switch pod bezel from the instrument panel. Refer to Switch Pod Bezel in Group 8E - Instrument Panel Systems for the procedures.
- (3) Remove the three screws that secure the heater-A/C control to the instrument panel (Fig. 38).

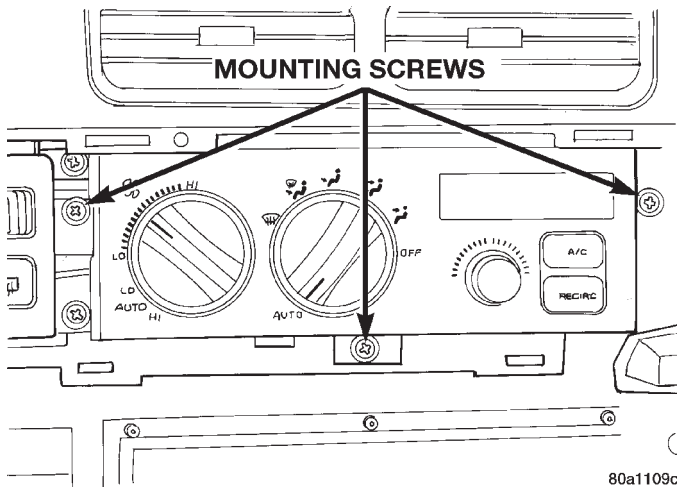


Fig. 38 Heater-A/C Control Remove/Install

- (4) Pull the heater-A/C control assembly away from the instrument panel far enough to access the connections on the back of the control.
- (5) Unplug the wire and/or vacuum harness connectors from the back of the heater-A/C control (Fig. 39).

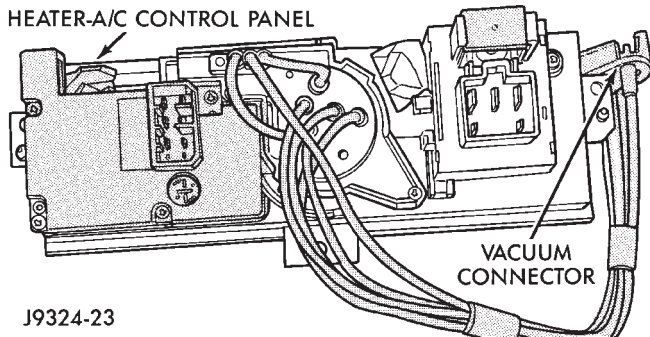


Fig. 39 Heater-A/C Control Connections - Typical

- (6) Remove the heater-A/C control from the instrument panel.

INSTALLATION

- (1) Plug the wire harness and/or vacuum harness connectors into the back of the heater-A/C control.
- (2) Position the heater-A/C control in the instrument panel and secure it with three screws. Tighten the screws to 2.2 N·m (20 in. lbs.).

- (3) Reinstall the inboard switch pod bezel onto the instrument panel. Refer to Switch Pod Bezel in Group 8E - Instrument Panel Systems for the procedures.
- (4) Connect the battery negative cable.

SOLAR SENSOR

The solar sensor is used only on models with the optional Automatic Temperature Control (ATC) system.

WARNING: ON VEHICLES EQUIPPED WITH AIRBAGS, REFER TO GROUP 8M - PASSIVE RESTRAINT SYSTEMS BEFORE ATTEMPTING ANY STEERING WHEEL, STEERING COLUMN, OR INSTRUMENT PANEL COMPONENT DIAGNOSIS OR SERVICE. FAILURE TO TAKE THE PROPER PRECAUTIONS COULD RESULT IN ACCIDENTAL AIRBAG DEPLOYMENT AND POSSIBLE PERSONAL INJURY.

REMOVAL

- (1) Disconnect and isolate the battery negative cable.
- (2) Using a trim stick or another suitable wide flat-bladed tool, gently pry the cowl top trim panel off of the instrument panel top pad (Fig. 40).

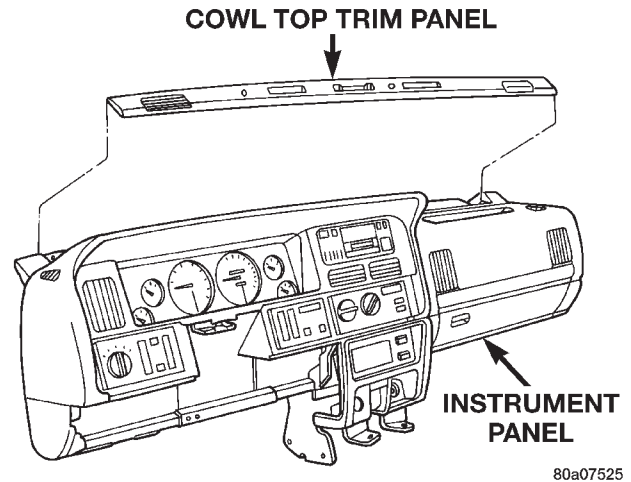
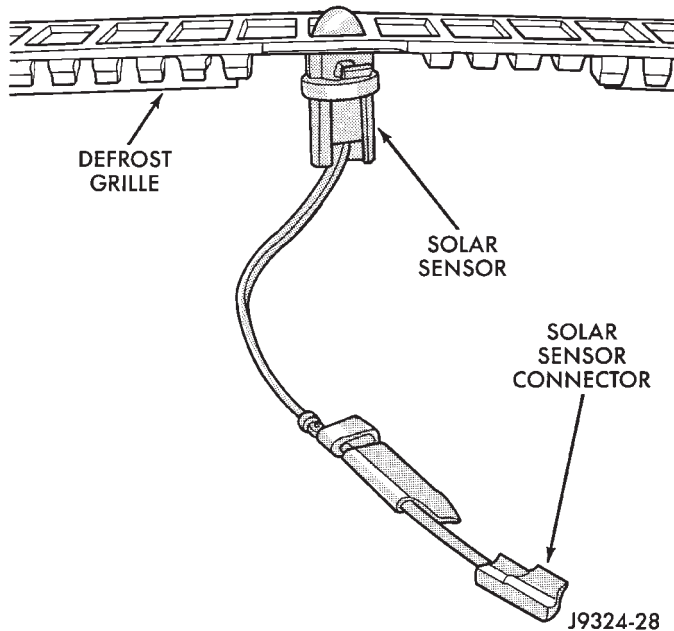


Fig. 40 Cowl Top Trim Remove/Install

- (3) Pull the trim panel up far enough to access the solar sensor, which is located between the passenger side and center defroster outlets.
- (4) Twist the solar sensor to remove it from the receptacle in the cowl top trim panel (Fig. 41).
- (5) Pull the sensor out from the instrument panel far enough to access and unplug the wire harness connector from the instrument panel wire harness.
- (6) Remove the solar sensor from the instrument panel.

REMOVAL AND INSTALLATION (Continued)**Fig. 41 Solar Sensor****INSTALLATION**

- (1) Plug the solar sensor wire harness connector into the instrument panel wire harness.
- (2) Insert the solar sensor into the receptacle on the bottom of the cowl top trim panel and twist the sensor to lock it into place.
- (3) Press the cowl top trim panel down until the snap clip retainers engage in the top of the instrument panel.
- (4) Connect the battery negative cable.

IN-VEHICLE TEMPERATURE SENSOR

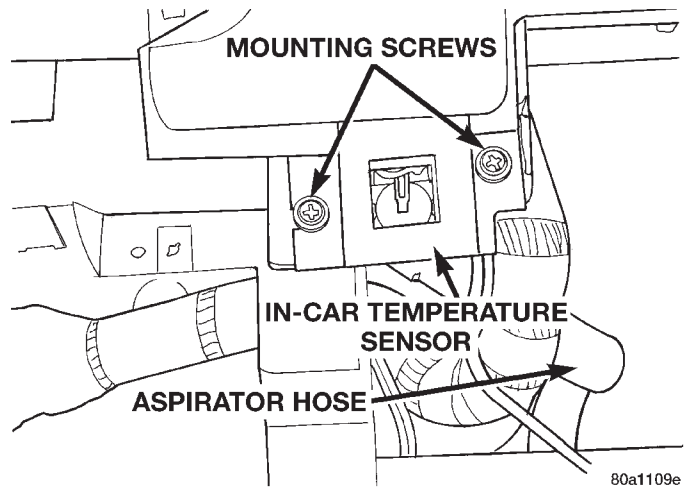
The in-vehicle temperature sensor is used only on models with the optional Automatic Temperature Control (ATC) system.

WARNING: ON VEHICLES EQUIPPED WITH AIRBAGS, REFER TO GROUP 8M - PASSIVE RESTRAINT SYSTEMS BEFORE ATTEMPTING ANY STEERING WHEEL, STEERING COLUMN, OR INSTRUMENT PANEL COMPONENT DIAGNOSIS OR SERVICE. FAILURE TO TAKE THE PROPER PRECAUTIONS COULD RESULT IN ACCIDENTAL AIRBAG DEPLOYMENT AND POSSIBLE PERSONAL INJURY.

REMOVAL

- (1) Disconnect and isolate the battery negative cable.
- (2) Remove the glove box module from the instrument panel. Refer to Glove Box Module in Group 8E - Instrument Panel Systems for the procedures.

- (3) Disconnect the in-vehicle temperature sensor aspirator hose at the in-line splice connector, located under the instrument panel near the passenger side of the floor panel transmission tunnel (Fig. 42).

**Fig. 42 In-Vehicle Temperature Sensor**

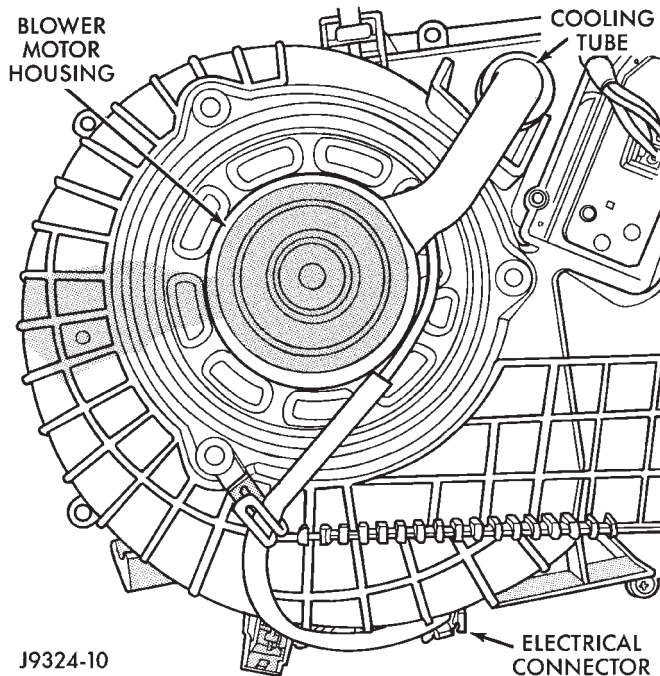
- (4) Reach behind the in-vehicle temperature sensor to unplug the wire harness connector from the instrument panel wire harness.
- (5) Remove the two screws that secure the in-vehicle temperature sensor to the instrument panel.
- (6) Remove the in-vehicle temperature sensor from the instrument panel.

INSTALLATION

- (1) Insert the in-vehicle temperature sensor into the instrument panel.
- (2) Install the two screws that secure the in-vehicle temperature sensor to the instrument panel. Tighten the mounting screws to 2.2 N·m (20 in. lbs.).
- (3) Plug the in-vehicle temperature sensor wire harness connector into the instrument panel wire harness.
- (4) Connect the in-vehicle temperature sensor aspirator hose to the in-line splice connector.
- (5) Reinstall the glove box module to the instrument panel. Refer to Glove Box Module in Group 8E - Instrument Panel Systems for the procedures.
- (6) Connect the battery negative cable.

BLOWER MOTOR**REMOVAL**

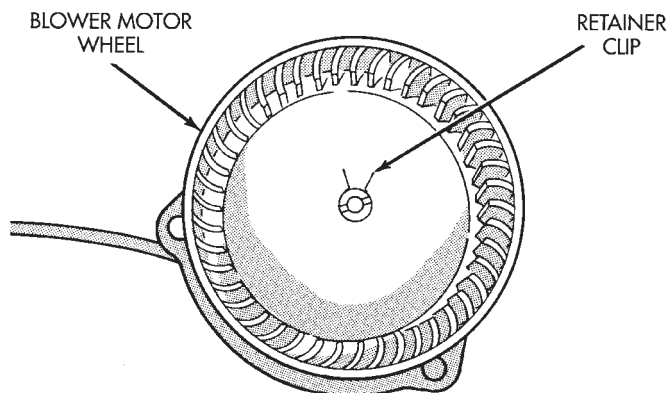
- (1) Disconnect and isolate the battery negative cable.
- (2) Disconnect the blower motor cooling tube from the nipple on the blower motor housing (Fig. 43).
- (3) Disengage the blower motor wire harness from the wire harness retainer.
- (4) Unplug the blower motor wire harness connector from the heater-A/C housing wire harness.

REMOVAL AND INSTALLATION (Continued)**Fig. 43 Blower Motor Remove/Install**

(5) Remove the three screws that secure the blower motor and wheel assembly to the heater-A/C housing.

(6) Lower the blower motor and wheel from the heater-A/C housing.

(7) Remove the blower wheel retainer clip (Fig. 44).

**Fig. 44 Blower Motor Wheel**

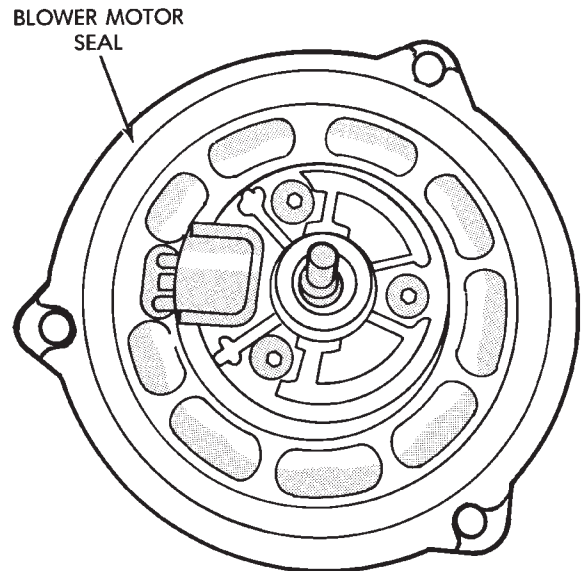
(8) Remove the blower wheel from the blower motor shaft

INSTALLATION

(1) Press the blower wheel hub onto the blower motor shaft. Be sure the flat on the shaft is indexed with the flat inside the hub.

(2) Install the blower wheel retainer clip. The ears of the retainer clip must be over the flat surface on the blower motor shaft.

(3) Be certain that the blower motor seal is installed on the blower motor housing (Fig. 45).

**Fig. 45 Blower Motor Seal**

(4) Install the blower motor in the heater-A/C housing with three mounting screws. Tighten the mounting screws to 2.2 N·m (20 in. lbs.).

(5) Plug the blower motor wire harness connector into the heater-A/C housing wire harness.

(6) Install the blower motor wire harness into the wire harness retainer.

(7) Connect the blower motor cooling tube to the nipple on the blower motor housing.

(8) Connect the battery negative cable.

BLOWER MOTOR RESISTOR AND POWER MODULE**REMOVAL**

(1) Disconnect and isolate the battery negative cable.

(2) Unplug the wire harness connector from the blower motor resistor or power module.

(3) Remove the screws that secure the blower motor resistor or power module to the heater-A/C housing.

(4) Remove the blower motor resistor or power module from the heater-A/C housing (Fig. 46).

INSTALLATION

(1) Install the blower motor resistor or power module to the heater-A/C housing. Tighten the mounting screws to 2.2 N·m (20 in. lbs.).

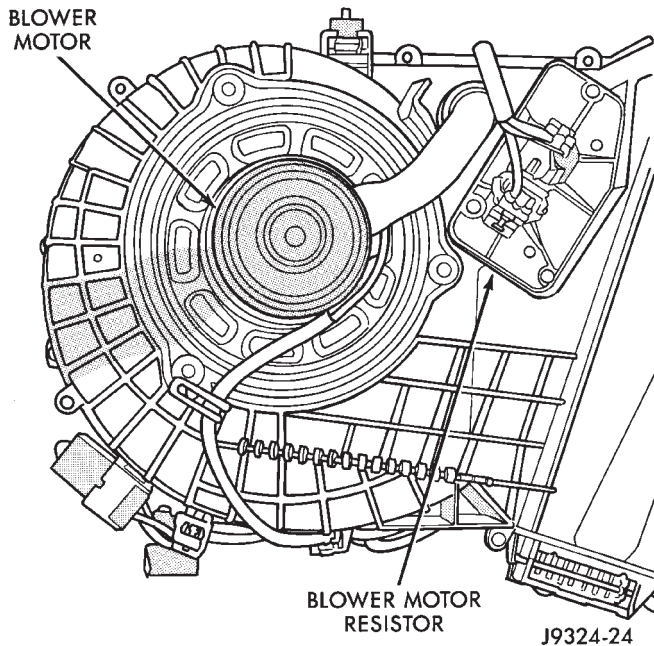
REMOVAL AND INSTALLATION (Continued)

Fig. 46 Blower Motor Resistor or Power Module Remove/Install

- (2) Plug in the wire harness connector to the blower motor resistor or power module.
- (3) Connect the battery negative cable.

DOOR ACTUATOR

WARNING: ON VEHICLES EQUIPPED WITH AIRBAGS, REFER TO GROUP 8M - PASSIVE RESTRAINT SYSTEMS BEFORE ATTEMPTING ANY STEERING WHEEL, STEERING COLUMN, OR INSTRUMENT PANEL COMPONENT DIAGNOSIS OR SERVICE. FAILURE TO TAKE THE PROPER PRECAUTIONS COULD RESULT IN ACCIDENTAL AIRBAG DEPLOYMENT AND POSSIBLE PERSONAL INJURY.

The mode door actuators for vehicles equipped with the standard equipment manual temperature control system are vacuum controlled. The optional Automatic Temperature Control (ATC) system uses electric motors to actuate the mode doors. The temperature/blend-air door for all models is actuated by an electric motor. The service procedures for both types of actuators are covered by the following procedures.

HEAT/DEFROST - PANEL/DEFROST DOOR MOTOR

This motor is used only on models equipped with the optional Automatic Temperature Control (ATC) system.

- (1) Disconnect and isolate the battery negative cable.

(2) Remove the two bolts that secure the center instrument panel support bracket to the left side of the floor panel transmission tunnel.

(3) Remove the two bolts that secure the center instrument panel support bracket to the instrument panel.

(4) Remove the center instrument panel support bracket from the vehicle.

(5) Unplug the wire harness connector from the heat/defrost - panel/defrost door motor (Fig. 47).

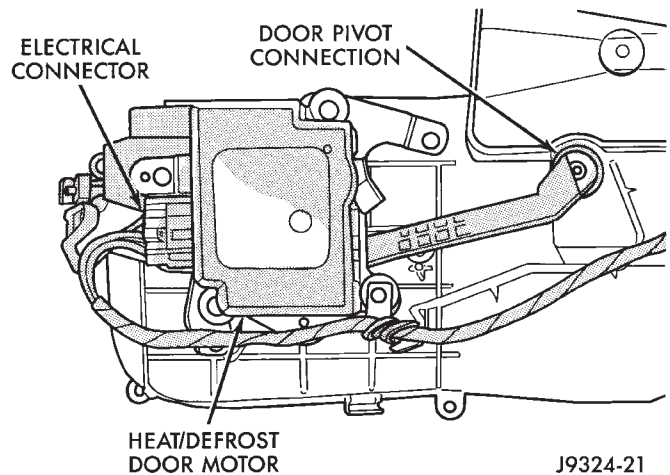


Fig. 47 Heat/Defrost - Panel/Defrost Door Motor Remove/Install

(6) Remove the three screws that secure the heat/defrost - panel/defrost door motor to the bottom of the heater-A/C housing.

(7) Remove the heat/defrost - panel/defrost door motor from the heater-A/C housing.

(8) Reverse the removal procedures to install. Tighten the mounting screws to 2.2 N·m (20 in. lbs.).

HEAT/DEFROST DOOR VACUUM ACTUATOR

This actuator is used only on models equipped with the standard manual temperature control system.

(1) Remove the heater-A/C housing from the vehicle. See Heater-A/C Housing in this group for the procedures.

(2) Turn the heater-A/C housing upside down on a work bench.

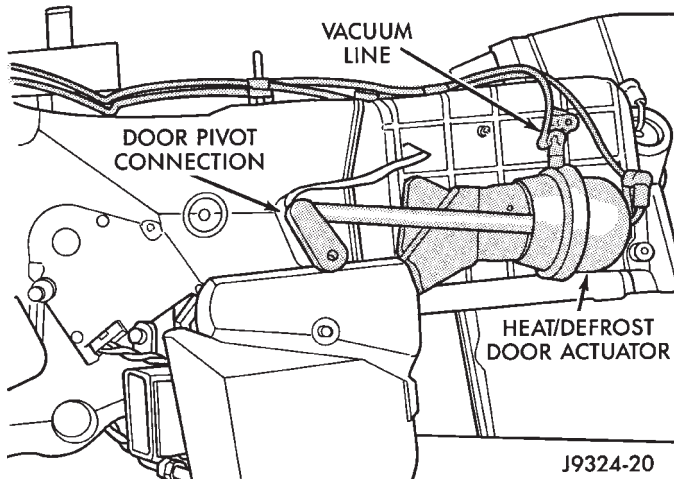
(3) Unplug the vacuum harness connector from the heat/defrost door vacuum actuator (Fig. 48).

(4) Disengage the heat/defrost door pivot connection from the heat/defrost door pivot pin.

(5) Remove the screws that secure the heat/defrost door vacuum actuator to the heater-A/C housing.

(6) Remove the heat/defrost door vacuum actuator from the heater-A/C housing.

(7) Reverse the removal procedures to install. Tighten the mounting screws to 2.2 N·m (20 in. lbs.).

REMOVAL AND INSTALLATION (Continued)

J9324-20

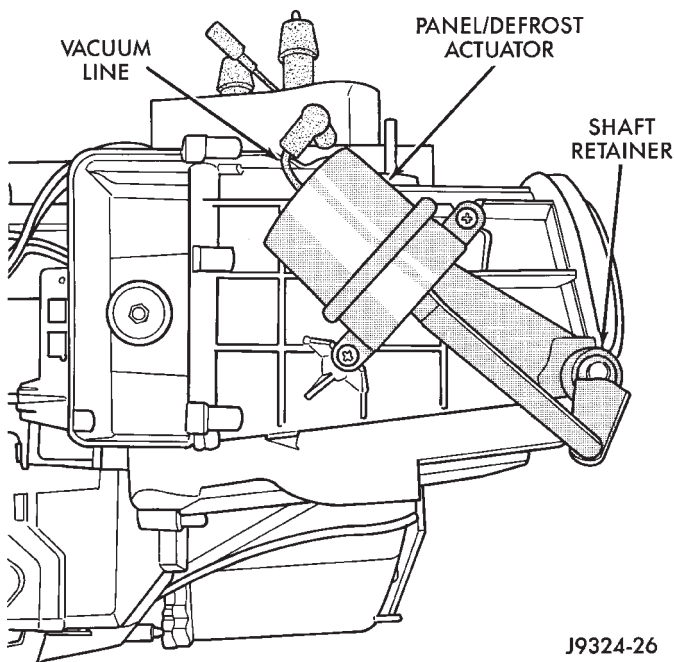
Fig. 48 Heat/Defrost Door Vacuum Actuator Remove/Install

PANEL/DEFROST DOOR VACUUM ACTUATOR

This actuator is used only on models equipped with the standard manual temperature control system.

(1) Remove the heater-A/C housing from the vehicle. See Heater-A/C Housing in this group for the procedures.

(2) Unplug the vacuum harness connector from the heat/defrost door vacuum actuator (Fig. 49).



J9324-26

Fig. 49 Panel/Defrost Door Vacuum Actuator Remove/Install

(3) Disengage the panel/defrost door pivot connection from the panel/defrost door pivot pin.

(4) Remove the screws that secure the panel/defrost door vacuum actuator to the heater-A/C housing.

(5) Remove the panel/defrost door vacuum actuator from the heater-A/C housing.

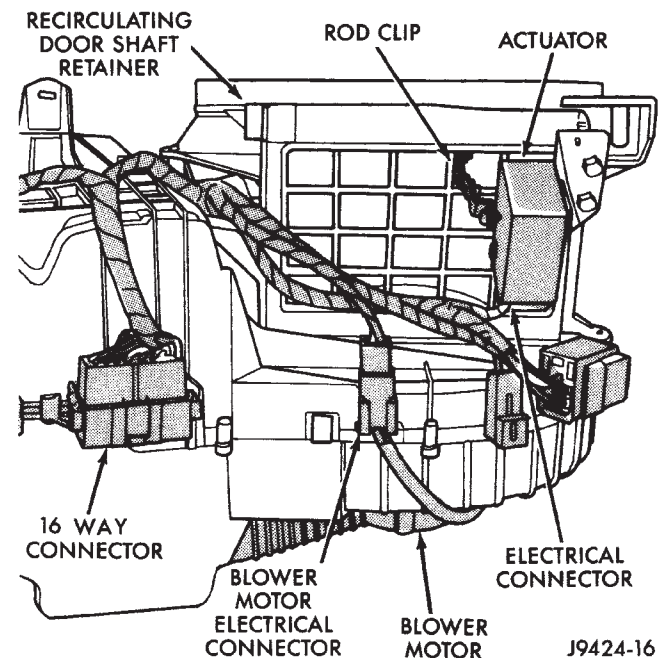
(6) Reverse the removal procedures to install. Tighten the mounting screws to 2.2 N·m (20 in. lbs.).

RECIRCULATION AIR DOOR MOTOR

This motor is used only on models equipped with the optional Automatic Temperature Control (ATC) system.

(1) Remove the instrument panel from the vehicle. Refer to Instrument Panel Assembly in Group 8E - Instrument Panel Systems for the procedures.

(2) Unplug the wire harness connector from the recirculation air door motor (Fig. 50).



J9424-16

Fig. 50 Recirculation Air Door Motor Remove/Install

(3) Unsnap the retaining clip from the recirculation air door actuating rod at the recirculation air door lever.

(4) Disengage the recirculation air door actuating rod from the recirculation air door lever.

(5) Remove the screws that secure the recirculation air door motor to the heater-A/C housing.

(6) Remove the recirculation air door motor from the heater-A/C housing.

(7) Reverse the removal procedures to install. Tighten the mounting screws to 2.2 N·m (20 in. lbs.).

REMOVAL AND INSTALLATION (Continued)**RECIRCULATION AIR DOOR VACUUM ACTUATOR**

This actuator is used only on models equipped with the standard manual temperature control system.

(1) Remove the instrument panel from the vehicle. Refer to Instrument Panel Assembly in Group 8E - Instrument Panel Systems for the procedures.

(2) Unplug the vacuum harness connector from the recirculation air door vacuum actuator (Fig. 51).

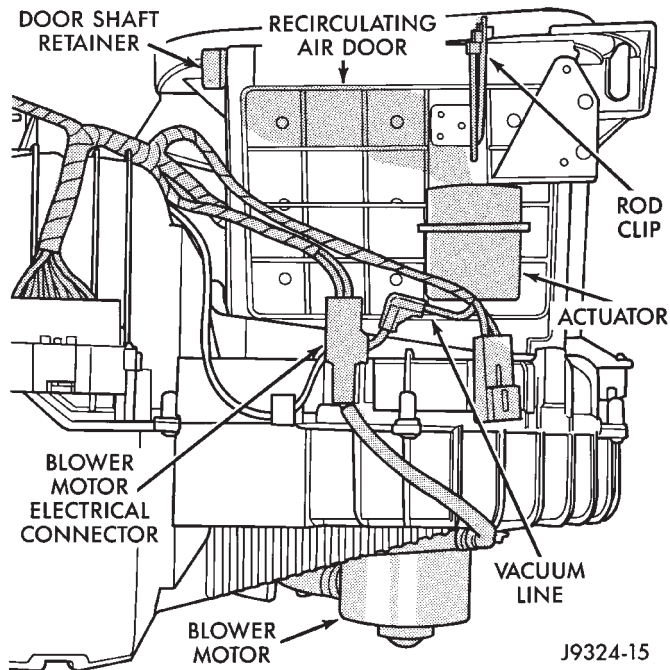


Fig. 51 Recirculation Air Door Vacuum Actuator Remove/Install

(3) Unsnap the retaining clip from the recirculation air door actuating rod at the recirculation air door lever.

(4) Disengage the recirculation air door actuating rod from the recirculation air door lever.

(5) Remove the screws that secure the recirculation air door vacuum actuator to the heater-A/C housing.

(6) Remove the recirculation air door vacuum actuator from the heater-A/C housing.

(7) Reverse the removal procedures to install. Tighten the mounting screws to 2.2 N·m (20 in. lbs.).

TEMPERATURE/BLEND-AIR DOOR MOTOR

The temperature/blend-air door motor is used on all models, whether equipped with manual or automatic temperature control. This motor is located under the heater-A/C housing directly over the floor panel transmission tunnel, and can be removed from the passenger compartment without instrument panel or heater-A/C housing removal.

(1) Disconnect and isolate the battery negative cable.

(2) Unplug the wire harness connector from the temperature/blend-air door motor (Fig. 52).

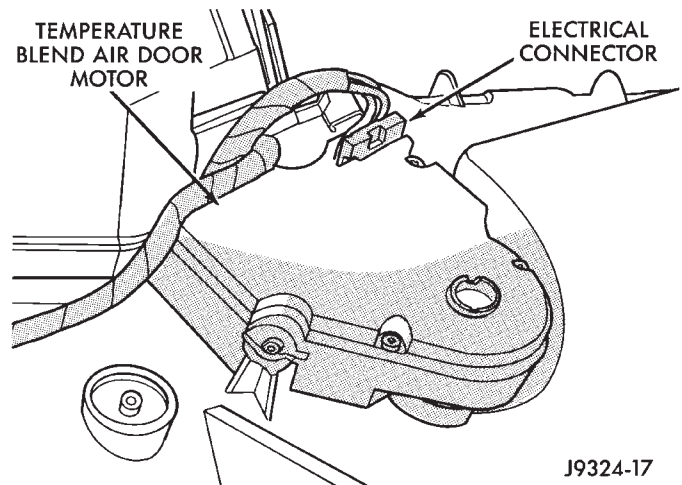


Fig. 52 Temperature/Blend-Air Door Motor Remove/Install

(3) Remove the screws that secure the temperature/blend-air door motor to the heater-A/C housing.

(4) Remove the temperature/blend-air door motor from the heater-A/C housing.

(5) Reverse the removal procedures to install. Tighten the mounting screws to 2.2 N·m (20 in. lbs.).

HEATER-A/C HOUSING

The heater-A/C housing assembly must be removed from the vehicle and the two halves of the housing separated for service access of the heater core, evaporator coil, blend-air door, and each of the various mode control doors.

WARNING: ON VEHICLES EQUIPPED WITH AIR-BAGS, REFER TO GROUP 8M - PASSIVE RESTRAINT SYSTEMS BEFORE ATTEMPTING ANY STEERING WHEEL, STEERING COLUMN, OR INSTRUMENT PANEL COMPONENT DIAGNOSIS OR SERVICE. FAILURE TO TAKE THE PROPER PRECAUTIONS COULD RESULT IN ACCIDENTAL AIR-BAG DEPLOYMENT AND POSSIBLE PERSONAL INJURY.

REMOVAL

(1) Disconnect and isolate the battery negative cable.

(2) Remove the instrument panel from the vehicle. Refer to Instrument Panel Assembly in Group 8E - Instrument Panel Systems for the procedures.

(3) Recover the refrigerant from the refrigerant system. See Refrigerant Recovery in this group for the procedures.

(4) Disconnect the liquid line refrigerant line coupler from the evaporator inlet tube. See Refrigerant

REMOVAL AND INSTALLATION (Continued)

Line Coupler in this group for the procedures. Install plugs in, or tape over all of the opened refrigerant line fittings.

(5) Disconnect the suction line refrigerant line coupler from the evaporator outlet tube. See Refrigerant Line Coupler in this group for the procedures. Install plugs in, or tape over all of the opened refrigerant line fittings.

(6) Drain the engine cooling system. Refer to Group 7 - Cooling System for the procedures.

(7) Disconnect the heater hoses from the heater core tubes. Refer to Group 7 - Cooling System for the procedures. Install plugs in, or tape over the opened heater core tubes.

(8) If the vehicle is equipped with the manual temperature control system, unplug the heater-A/C system vacuum supply line connector from the tee fitting near the heater core tubes.

(9) Remove the coolant reserve/overflow bottle from the passenger side inner fender shield. Refer to Group 7 - Cooling System for the procedures.

(10) Remove the Powertrain Control Module (PCM) from the passenger side dash panel in the engine compartment and set it aside. Do not unplug the PCM wire harness connectors. Refer to Group 14 - Fuel System for the procedures.

(11) Remove the nuts from the heater-A/C housing mounting studs on the engine compartment side of the dash panel (Fig. 53).

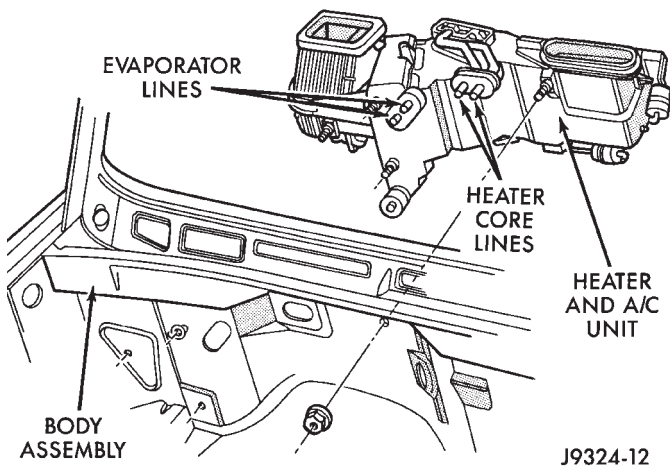


Fig. 53 Heater-A/C Housing Remove/Install

(12) Disengage the rear floor heat duct from the center floor heat duct adapter (Fig. 54).

(13) Unplug the heater-A/C housing wire harness connectors.

(14) Remove the heater-A/C housing mounting nuts from the studs on the passenger compartment side of the dash panel (Fig. 55).

(15) Remove the heater-A/C housing from the vehicle.

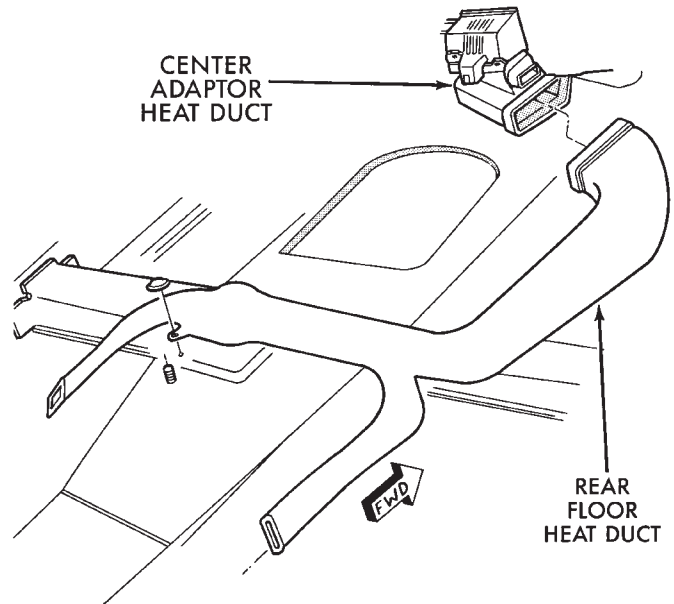


Fig. 54 Rear Floor Heat Duct

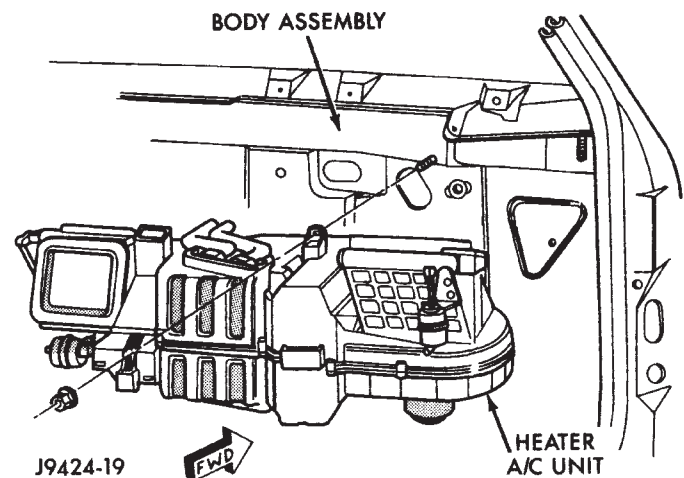


Fig. 55 Heater A/C Housing Remove/Install

INSTALLATION

(1) Position the heater-A/C housing to the dash panel. Be certain that the evaporator condensate drain tube and the housing mounting studs are inserted into their correct mounting holes.

(2) Install the heater-A/C housing mounting nuts to the studs on the passenger compartment side of the dash panel. Tighten the nuts to 4.5 N·m (40 in. lbs.).

(3) Connect the heater-A/C housing wire harness connectors.

(4) Reinstall the rear floor heat duct to the center floor heat duct adapter.

(5) Install and tighten the nuts onto the heater-A/C housing mounting studs on the engine compart-

REMOVAL AND INSTALLATION (Continued)

ment side of the dash panel. Tighten the nuts to 7 N·m (60 in. lbs.).

(6) Reinstall the PCM to the passenger side dash panel in the engine compartment. Refer to Group 14 - Fuel System for the procedures.

(7) Reinstall the coolant reserve/overflow bottle to the passenger side inner fender shield. Refer to Group 7 - Cooling System for the procedures.

(8) If the vehicle is equipped with the manual temperature control system, connect the heater-A/C system vacuum supply line connector to the tee fitting near the heater core tubes.

(9) Unplug or remove the tape from the heater core tubes. Connect the heater hoses to the heater core tubes and fill the engine cooling system. Refer to Group 7 - Cooling System for the procedures.

(10) Unplug or remove the tape from the suction line and the evaporator outlet tube fittings. Connect the suction line coupler to the evaporator outlet tube. See Refrigerant Line Coupler in this group for the procedures.

(11) Unplug or remove the tape from the liquid line and the evaporator inlet tube fittings. Connect the liquid line coupler to the evaporator inlet tube. See Refrigerant Line Coupler in this group for the procedures.

(12) Evacuate the refrigerant system. See Refrigerant System Evacuate in this group for the procedures.

(13) Charge the refrigerant system. See Refrigerant System Charge in this group for the procedures.

(14) Install the instrument panel in the vehicle. Refer to Group 8E - Instrument Panel Systems for the procedures.

(15) Connect the battery negative cable.

(16) Start the engine and check for proper operation of the heating and air conditioning systems.

HEATER CORE

WARNING: ON VEHICLES EQUIPPED WITH AIRBAGS, REFER TO GROUP 8M - PASSIVE RESTRAINT SYSTEMS BEFORE ATTEMPTING ANY STEERING WHEEL, STEERING COLUMN, OR INSTRUMENT PANEL COMPONENT DIAGNOSIS OR SERVICE. FAILURE TO TAKE THE PROPER PRECAUTIONS COULD RESULT IN ACCIDENTAL AIRBAG DEPLOYMENT AND POSSIBLE PERSONAL INJURY.

REMOVAL

(1) Remove the heater-A/C housing from the vehicle. See Heater-A/C Housing in this group for the procedures.

(2) Remove the screws and retainers that secure the heater core to the heater-A/C housing.

(3) Lift the heater core straight up and out of the heater-A/C housing (Fig. 56).

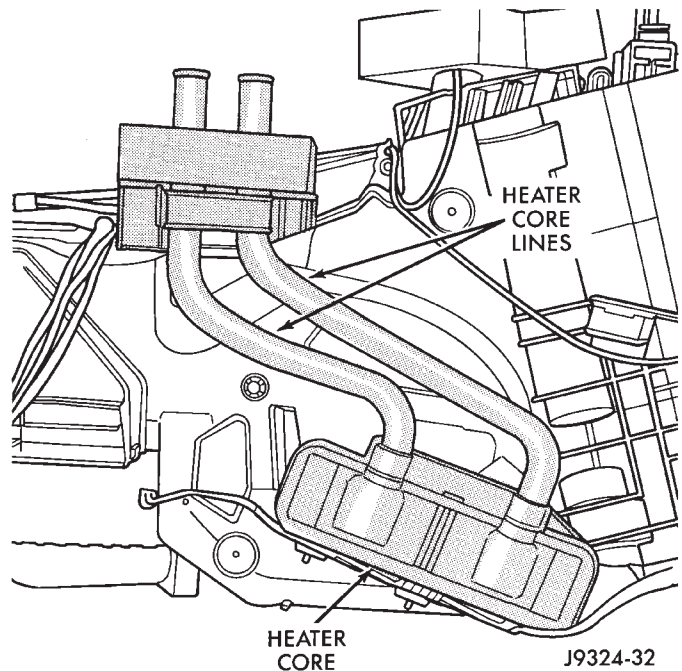


Fig. 56 Heater Core Remove/Install

INSTALLATION

(1) Lower the heater core into the heater-A/C housing.

(2) Position the retainers over the heater core tubes. Install and tighten the screws that secure the heater core and retainers to the heater-A/C housing. Tighten the screws to 2.2 N·m (20 in. lbs.).

(3) Reinstall the heater-A/C housing to the vehicle. See Heater-A/C Housing in this group for the procedures.

HEATER-A/C HOUSING DOOR

WARNING: ON VEHICLES EQUIPPED WITH AIRBAGS, REFER TO GROUP 8M - PASSIVE RESTRAINT SYSTEMS BEFORE ATTEMPTING ANY STEERING WHEEL, STEERING COLUMN, OR INSTRUMENT PANEL COMPONENT DIAGNOSIS OR SERVICE. FAILURE TO TAKE THE PROPER PRECAUTIONS COULD RESULT IN ACCIDENTAL AIRBAG DEPLOYMENT AND POSSIBLE PERSONAL INJURY.

TEMPERATURE/BLEND-AIR DOOR

(1) Remove the heater-A/C housing from the vehicle. See Heater-A/C Housing in this group for the procedures.

(2) Place the heater-A/C housing upside down on a work bench.

REMOVAL AND INSTALLATION (Continued)

(3) Unsnap the center floor heat duct adapter from the bottom of the heater-A/C housing.

(4) Remove the screws that secure the two housing halves to each other.

(5) Turn the heater-A/C housing right side up on the work bench and separate the top half of the heater-A/C housing from the bottom half.

(6) Lift the temperature/blend-air door pivot shaft out of the pivot hole in the bottom half of the heater-A/C housing (Fig. 57).

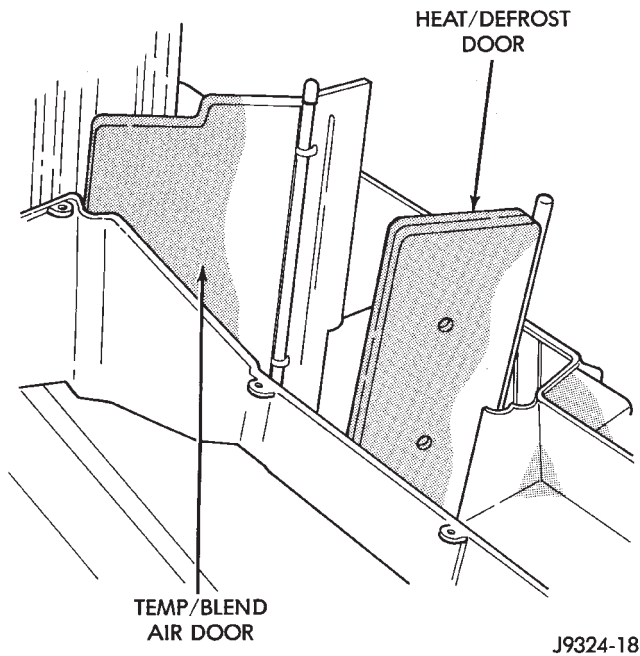


Fig. 57 Temperature/Blend-Air Door and Heat/Defrost Door Remove/Install

NOTE: To reinstall the door-to-motor pivot connection, the motor must be removed from the heater-A/C housing. See Door Actuator in this group for the procedures.

(7) Reverse the removal procedures to install. Be certain that each of the door pivot pins align with the pivot holes in the heater-A/C housing. Tighten the heater-A/C housing screws to 2.2 N·m (20 in. lbs.).

PANEL/DEFROST DOOR AND LEVER

(1) Remove the instrument panel from the vehicle. Refer to Instrument Panel Assembly in Group 8E - Instrument Panel Systems for the procedures.

(2) Disengage the panel/defrost door actuating rod from the door pivot shaft retainer (Fig. 58) or (Fig. 59).

(3) Using a trim stick or another suitable wide flat-bladed tool, gently pry the panel/defrost door pivot shaft retainer from the pivot shaft.

(4) Remove the panel/defrost door through the top opening of the heater-A/C housing.

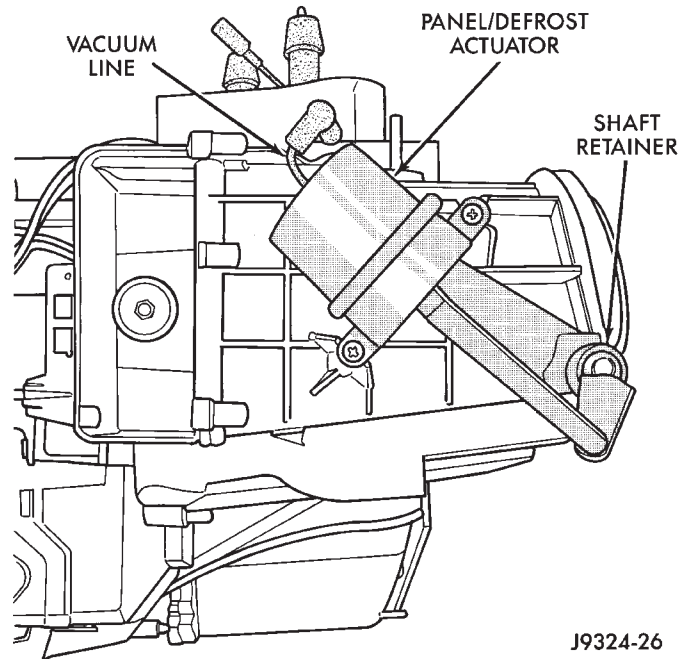


Fig. 58 Panel/Defrost Door Remove/Install - Manual Temperature Control

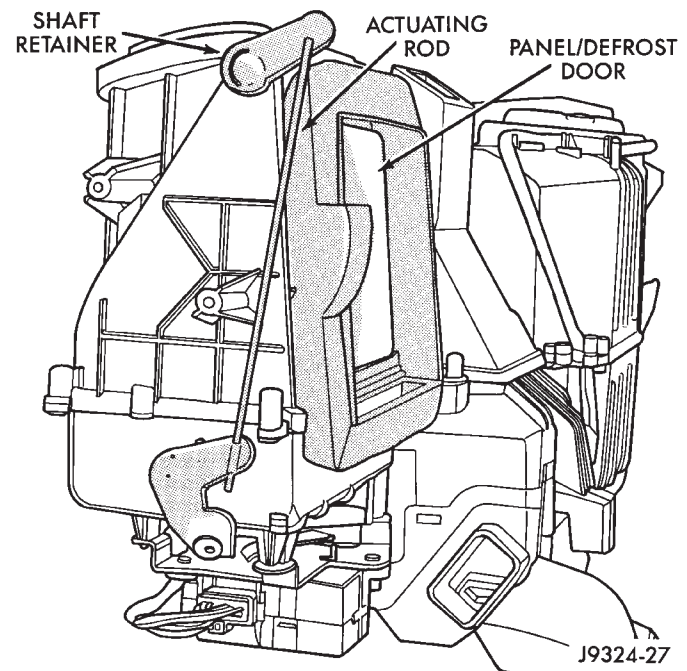


Fig. 59 Panel/Defrost Door Remove/Install - Automatic Temperature Control

(5) Reverse the removal procedures to install.

HEAT/DEFROST DOOR

(1) Remove the heater-A/C housing from the vehicle. See Heater-A/C Housing in this group for the procedures.

(2) Place the heater-A/C housing upside down on a work bench.

REMOVAL AND INSTALLATION (Continued)

(3) Remove the heat/defrost - panel/defrost door motor (ATC) or heat/defrost door vacuum actuator (manual) from the heater-A/C housing. See Door Actuator in this group for the procedures.

(4) Unsnap the center floor heat duct adapter from the bottom of the heater-A/C housing.

(5) Remove the screws that secure the two housing halves to each other.

(6) Turn the heater-A/C housing right side up on the work bench and separate the top half of the heater-A/C housing from the bottom half.

(7) Lift the heat/defrost door pivot shaft out of the pivot hole in the bottom half of the heater-A/C housing (Fig. 57).

(8) Reverse the removal procedures to install. Be certain that each of the door pivot pins align with the pivot holes in the heater-A/C housing. Tighten the heater-A/C housing screws to 2.2 N·m (20 in. lbs.).

RECIRCULATION AIR DOOR

(1) Remove the heater-A/C housing from the vehicle. See Heater-A/C Housing in this group for the procedures.

(2) Unsnap the retaining clip from the recirculation air door actuating rod at the recirculation air door lever.

(3) Using a trim stick or another suitable wide flat-bladed tool, gently pry the recirculation air door pivot shaft retainer from the pivot shaft.

(4) Remove the recirculation air door through the top opening of the heater-A/C housing.

(5) Reverse the removal procedures to install.

EVAPORATOR COIL

WARNING: ON VEHICLES EQUIPPED WITH AIRBAGS, REFER TO GROUP 8M - PASSIVE RESTRAINT SYSTEMS BEFORE ATTEMPTING ANY STEERING WHEEL, STEERING COLUMN, OR INSTRUMENT PANEL COMPONENT DIAGNOSIS OR SERVICE. FAILURE TO TAKE THE PROPER PRECAUTIONS COULD RESULT IN ACCIDENTAL AIRBAG DEPLOYMENT AND POSSIBLE PERSONAL INJURY.

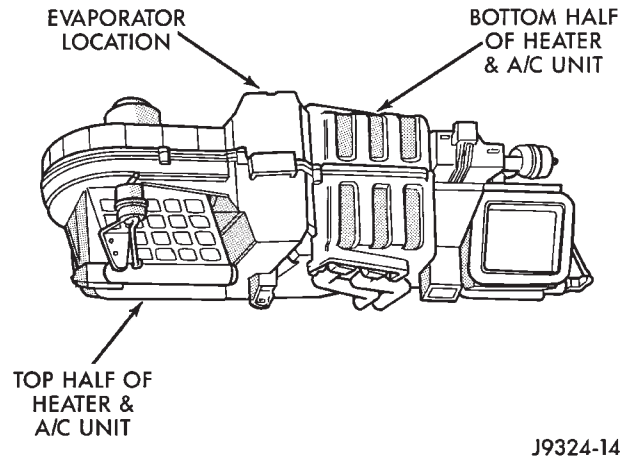
(1) Remove the heater-A/C housing from the vehicle. See Heater-A/C Housing in this group for the procedures.

(2) Place the heater-A/C housing upside down on a work bench.

(3) Unsnap the center floor heat duct adapter from the bottom of the heater-A/C housing.

(4) Remove the screws that secure the two housing halves to each other.

(5) Turn the heater-A/C housing right side up on the work bench and separate the top half of the heater-A/C housing from the bottom half (Fig. 60).



J9324-14

Fig. 60 Evaporator Coil Location in Heater-A/C Housing (Upside Down)

(6) Lift the evaporator coil unit out of the lower half of the heater-A/C housing.

(7) Reverse the removal procedures to install. Be certain that the evaporator foam insulator wrap is reinstalled. Be certain that each of the door pivot pins align with the pivot holes in the heater-A/C housing. Tighten the heater-A/C housing screws to 2.2 N·m (20 in. lbs.).

NOTE: If the evaporator is replaced, add 60 milliliters (2 fluid ounces) of refrigerant oil to the refrigerant system.

DUCTS AND OUTLETS**DEFROSTER DUCT**

(1) Remove the instrument panel assembly from the vehicle. See Instrument Panel Assembly in Group 8E - Instrument Panel Systems for the procedures.

(2) Remove the three screws that secure the defroster duct to the instrument panel armature.

(3) Remove the defroster duct from the instrument panel.

(4) Reverse the removal procedures to install. Tighten the mounting screws to 2.2 N·m (20 in. lbs.).

DEMISTER DUCT

(1) Remove the defroster duct from the instrument panel. See Defroster Duct in this group for the procedures.

(2) Remove the screws that secure the demister duct to the instrument panel armature.

(3) Remove the demister duct from the instrument panel.

(4) Reverse the removal procedures to install. Tighten the mounting screws to 2.2 N·m (20 in. lbs.).

REMOVAL AND INSTALLATION (Continued)

PANEL DUCT

- (1) Remove the demister duct from the instrument panel. See Demister Duct in this group for the procedures.
- (2) Remove the screws that secure the panel duct to the instrument panel armature.
- (3) Remove the panel duct from the instrument panel.
- (4) Reverse the removal procedures to install. Tighten the mounting screws to 2.2 N·m (20 in. lbs.).

FLOOR DUCT

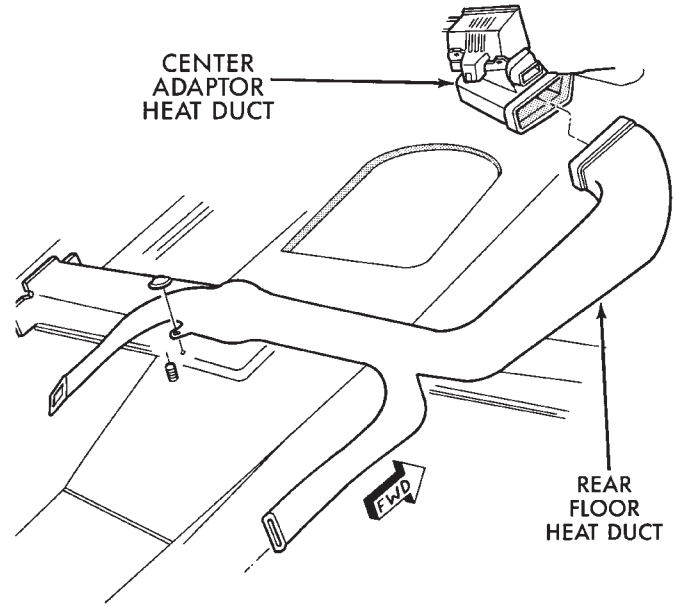
- (1) Remove the center floor console from the vehicle. Refer to Group 23 - Body for the procedures.
- (2) Remove the right front seat from the vehicle. Refer to Group 23 - Body for the procedures.
- (3) Remove the right side front door opening trim from the vehicle. Refer to Group 23 - Body for the procedures.
- (4) Roll back the floor carpeting.
- (5) Remove the nut that secures the floor duct to the stud on the floor panel transmission tunnel (Fig. 61).
- (6) Disconnect the floor duct from the center floor heat duct adapter.
- (7) Remove the floor duct from the vehicle.
- (8) Reverse the removal procedures to install.

DEMISTER OUTLETS

- (1) Using a trim stick or another suitable wide flat-bladed tool, gently pry the edge of the outlet away from the instrument panel top pad.
- (2) To install, push the outlet firmly into the hole in the instrument panel top pad.

PANEL OUTLETS

The driver side and center panel outlets are only serviced as part of the instrument cluster bezel unit.



J9324-30

Fig. 61 Floor Duct Remove/Install

The passenger side panel outlets are available for service.

- (1) Remove the instrument panel top pad from the instrument panel. Refer to Instrument Panel Top Pad in Group 8E - Instrument Panel Systems for the procedures.
- (2) Remove the two screws that secure each outlet to the instrument panel side of the top pad.
- (3) Remove the outlet from the top pad.
- (4) Reverse the removal procedures to install. Tighten the mounting screws to 2.2 N·m (20 in. lbs.).

HEATING AND AIR CONDITIONING

CONTENTS

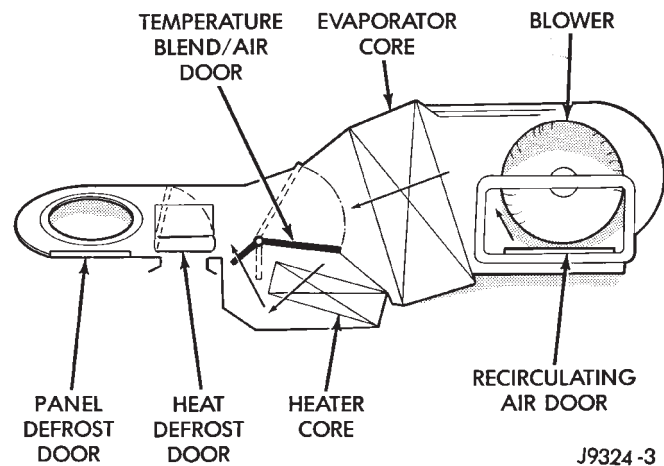
	page	page
GENERAL INFORMATION		
HEATER AND AIR CONDITIONER CONTROLS ..	2	
HEATER AND AIR CONDITIONER	1	
SERVICE WARNINGS AND PRECAUTIONS	2	
DESCRIPTION AND OPERATION		
COMPRESSOR CLUTCH	4	
COMPRESSOR	4	
DIAGNOSIS AND TESTING		
COMPRESSOR CLUTCH COIL	5	
COMPRESSOR	5	
REMOVAL AND INSTALLATION		
COMPRESSOR CLUTCH	8	
COMPRESSOR	7	
REFRIGERANT LINE COUPLER	6	

GENERAL INFORMATION

HEATER AND AIR CONDITIONER

A manual temperature control type heating-air conditioning system is standard factory-installed equipment on this model. An electronically controlled Automatic Temperature Control (ATC) type heating-air conditioning system is an available factory-installed option.

All vehicles are equipped with a common heater-A/C housing assembly (Fig. 1). The system combines air conditioning, heating, and ventilating capabilities in a single unit housing mounted under the instrument panel.



J9324 -3

Fig. 1 Common Blend-Air Heater-Air Conditioner System

Outside fresh air enters the vehicle through the cowl top opening at the base of the windshield, and passes through a plenum chamber to the heater-A/C system blower housing. Air flow velocity can then be adjusted with the blower motor speed selector switch on the heater-A/C control panel. The air intake openings must be kept free of snow, ice, leaves, and other

obstructions for the heater-A/C system to receive a sufficient volume of outside air.

Both the manual and ATC heater and air conditioner are blend-air type systems. In a blend-air system, a blend-air door controls the amount of cooled or unconditioned air is allowed to flow through, or around, the heater core. A temperature control knob on the heater-A/C control panel determines the discharge air temperature by energizing the blend-air door motor, which operates the blend-air door. This allows an almost immediate control of the output air temperature of the system.

The mode control knob on the heater-A/C control panel is used to direct the conditioned air to the selected system outlets. On manual temperature control systems, the mode control knob switches engine vacuum to control the mode doors, which are operated by vacuum actuator motors. On ATC systems, the mode control knob switches electrical current to control the mode doors, which are operated by electronic actuator motors.

The outside air intake can be shut off by selecting the recirculation mode with the mode control knob. This will open the recirculating air door and recirculate the air that is already inside the vehicle.

The air conditioner for all models is designed for the use of non-CFC, R-134a refrigerant. The air conditioning system has an evaporator to cool and dehumidify the incoming fresh or recirculated air prior to blending it with the heated air. This air conditioning system uses a fixed orifice tube in the condenser outlet line to meter refrigerant flow to the evaporator coil. To maintain minimum evaporator temperature and prevent evaporator freezing, a fixed pressure setting switch on the accumulator cycles the compressor clutch.

GENERAL INFORMATION (Continued)

NOTE: This group covers both Left-Hand Drive (LHD) and Right-Hand Drive (RHD) versions of this model. Whenever required and feasible, the RHD versions of affected vehicle components have been constructed as mirror-image of the LHD versions. While most of the illustrations used in this group represent only the LHD version, the diagnostic and service procedures outlined can generally be applied to either version. Exceptions to this rule have been clearly identified as LHD or RHD, if a special illustration or procedure is required.

HEATER AND AIR CONDITIONER CONTROLS

The manual temperature control heater-A/C system uses a combination of electrical, and vacuum controls. The ATC heater-A/C system uses only electrical controls. These controls provide the vehicle operator with a number of setting options to help control the climate and comfort within the vehicle. Refer to the owner's manual for more information on the suggested operation and use of these controls.

Both heater-A/C control panels are located inboard of the instrument cluster on the instrument panel (Fig. 2). Both control panels have a temperature control knob, a mode control knob, a blower motor switch knob, and an air conditioning compressor pushbutton switch. The ATC control panel includes a Recirc pushbutton switch and a vacuum fluorescent display area.

wired sensor inputs and messages received on the CCD data bus network to control the many functions and features of the ATC system.

Both the manual heater-A/C control panel and the ATC control panel and controller units cannot be repaired. If faulty or damaged, the entire unit must be replaced.

SERVICE WARNINGS AND PRECAUTIONS

WARNING:

- **THE AIR CONDITIONING SYSTEM CONTAINS REFRIGERANT UNDER HIGH PRESSURE. SEVERE PERSONAL INJURY MAY RESULT FROM IMPROPER SERVICE PROCEDURES. REPAIRS SHOULD ONLY BE PERFORMED BY QUALIFIED SERVICE PERSONNEL.**

- **AVOID BREATHING THE REFRIGERANT AND REFRIGERANT OIL VAPOR OR MIST. EXPOSURE MAY IRRITATE THE EYES, NOSE, AND/OR THROAT. WEAR EYE PROTECTION WHEN SERVICING THE AIR CONDITIONING REFRIGERANT SYSTEM. SERIOUS EYE INJURY CAN RESULT FROM DIRECT CONTACT WITH THE REFRIGERANT. IF EYE CONTACT OCCURS, SEEK MEDICAL ATTENTION IMMEDIATELY.**

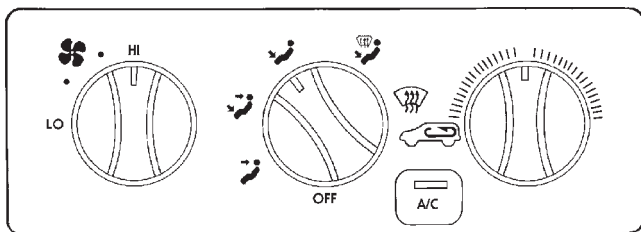
- **DO NOT EXPOSE THE REFRIGERANT TO OPEN FLAME. POISONOUS GAS IS CREATED WHEN REFRIGERANT IS BURNED. AN ELECTRONIC LEAK DETECTOR IS RECOMMENDED.**

- **IF ACCIDENTAL SYSTEM DISCHARGE OCCURS, VENTILATE THE WORK AREA BEFORE RESUMING SERVICE. LARGE AMOUNTS OF REFRIGERANT RELEASED IN A CLOSED WORK AREA WILL DISPLACE THE OXYGEN AND CAUSE SUFFOCATION.**

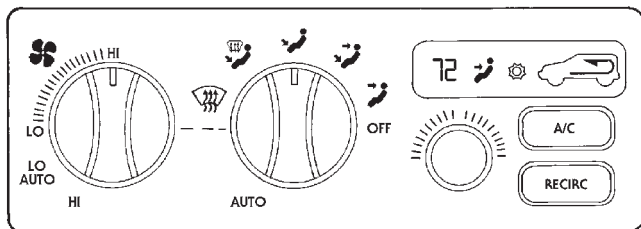
- **THE EVAPORATION RATE OF R-134a REFRIGERANT AT AVERAGE TEMPERATURE AND ALTITUDE IS EXTREMELY HIGH. AS A RESULT, ANYTHING THAT COMES IN CONTACT WITH THE REFRIGERANT WILL FREEZE. ALWAYS PROTECT THE SKIN OR DELICATE OBJECTS FROM DIRECT CONTACT WITH THE REFRIGERANT.**

- **THE R-134a SERVICE EQUIPMENT OR THE VEHICLE REFRIGERANT SYSTEM SHOULD NOT BE PRESSURE TESTED OR LEAK TESTED WITH COMPRESSED AIR. SOME MIXTURES OF AIR AND R-134a HAVE BEEN SHOWN TO BE COMBUSTIBLE AT ELEVATED PRESSURES. THESE MIXTURES ARE POTENTIALLY DANGEROUS, AND MAY RESULT IN FIRE OR EXPLOSION CAUSING INJURY OR PROPERTY DAMAGE.**

MANUAL AIR CONDITIONING SYSTEM



AUTOMATIC TEMPERATURE CONTROL SYSTEM



80a1376e

Fig. 2 Heater-Air Conditioner Control Panels

The ATC control panel also includes the ATC controller. The ATC controller contains a microprocessor and uses internal programming along with hard-

GENERAL INFORMATION (Continued)

CAUTION:

- Liquid refrigerant is corrosive to metal surfaces. Follow the operating instructions supplied with the service equipment being used.
- Never add R-12 to a refrigerant system designed to use R-134a. Damage to the system will result.
- R-12 refrigerant oil must not be mixed with R-134a refrigerant oil. They are not compatible.
- Do not use R-12 equipment or parts on the R-134a system. Damage to the system will result.
- Do not overcharge the refrigerant system. This will cause excessive compressor head pressure and can cause noise and system failure.
- Recover the refrigerant before opening any fitting or connection. Open the fittings with caution, even after the system has been discharged. Never open or loosen a connection before recovering the refrigerant.
- Do not remove the secondary retention clip from any spring-lock coupler connection while the refrigerant system is under pressure. Recover the refrigerant before removing the secondary retention clip. Open the fittings with caution, even after the system has been discharged. Never open or loosen a connection before recovering the refrigerant.
- The refrigerant system must always be evacuated before charging.
- Do not open the refrigerant system or uncap a replacement component until you are ready to service the system. This will prevent contamination in the system.
- Before disconnecting a component, clean the outside of the fittings thoroughly to prevent contamination from entering the refrigerant system.
- Immediately after disconnecting a component from the refrigerant system, seal the open fittings with a cap or plug.
- Before connecting an open refrigerant fitting, always install a new seal or gasket. Coat the fitting and seal with clean refrigerant oil before connecting.
- Do not remove the sealing caps from a replacement component until it is to be installed.
- When installing a refrigerant line, avoid sharp bends that may restrict refrigerant flow. Position the refrigerant lines away from exhaust system components or any sharp edges, which may damage the line.
- Tighten refrigerant fittings only to the specified torque. The aluminum fittings used in the refrigerant system will not tolerate overtightening.
- When disconnecting a refrigerant fitting, use a wrench on both halves of the fitting. This will prevent twisting of the refrigerant lines or tubes.

- Refrigerant oil will absorb moisture from the atmosphere if left uncapped. Do not open a container of refrigerant oil until you are ready to use it. Replace the cap on the oil container immediately after using. Store refrigerant oil only in a clean, airtight, and moisture-free container.

- Keep service tools and the work area clean. Contamination of the refrigerant system through careless work habits must be avoided.

COOLING SYSTEM REQUIREMENTS

To maintain the performance level of the heating-air conditioning system, the engine cooling system must be properly maintained. The use of a bug screen is not recommended. Any obstructions in front of the radiator or condenser will reduce the performance of the air conditioning and engine cooling systems.

The engine cooling system includes the heater core and the heater hoses. Refer to Group 7 - Cooling System for more information before the opening of, or attempting any service to the engine cooling system.

REFRIGERANT HOSES/LINES/TUBES PRECAUTIONS

Kinks or sharp bends in the refrigerant plumbing will reduce the capacity of the entire system. High pressures are produced in the system when it is operating. Extreme care must be exercised to make sure that all refrigerant system connections are pressure tight.

A good rule for the flexible hose refrigerant lines is to keep the radius of all bends at least ten times the diameter of the hose. Sharp bends will reduce the flow of refrigerant. The flexible hose lines should be routed so they are at least 80 millimeters (3 inches) from the exhaust manifold. It is a good practice to inspect all flexible refrigerant system hose lines at least once a year to make sure they are in good condition and properly routed.

There are two types of refrigerant fittings:

- All fittings with O-rings need to be coated with refrigerant oil before installation. Use only O-rings that are the correct size and approved for use with R-134a refrigerant. Failure to do so may result in a leak.
- Unified plumbing connections with gaskets cannot be serviced with O-rings. The gaskets are not reusable and new gaskets do not require lubrication before installing.

Using the proper tools when making a refrigerant plumbing connection is very important. Improper tools or improper use of the tools can damage the refrigerant fittings. Always use two wrenches when loosening or tightening tube fittings. Use one wrench to hold one side of the connection stationary, while

GENERAL INFORMATION (Continued)

loosening or tightening the other side of the connection with a second wrench.

The refrigerant must be recovered completely from the system before opening any fitting or connection. Open the fittings with caution, even after the refrigerant has been recovered. If any pressure is noticed as a fitting is loosened, tighten the fitting and recover the refrigerant from the system again.

Do not discharge refrigerant into the atmosphere. Use an R-134a refrigerant recovery/recycling device that meets SAE Standard J2210.

The refrigerant system will remain chemically stable as long as pure, moisture-free R-134a refrigerant and refrigerant oil is used. Dirt, moisture, or air can upset this chemical stability. Operational troubles or serious damage can occur if foreign material is present in the refrigerant system.

When it is necessary to open the refrigerant system, have everything needed to service the system ready. The refrigerant system should not be left open to the atmosphere any longer than necessary. Cap or plug all lines and fittings as soon as they are opened to prevent the entrance of dirt and moisture. All lines and components in parts stock should be capped or sealed until they are to be installed.

All tools, including the refrigerant recycling equipment, the manifold gauge set, and test hoses should be kept clean and dry. All tools and equipment must be designed for R-134a refrigerant.

DESCRIPTION AND OPERATION

COMPRESSOR

The air conditioning system uses a Nippon Denso 10PA17 ten cylinder, double-acting swash plate-type compressor on all models. This compressor has a fixed displacement of 170 cubic centimeters (10.374 cubic inches), and has both the suction and discharge ports located on the cylinder head. A label identifying the use of R-134a refrigerant is located on the compressor.

The compressor is driven by the engine through an electric clutch, drive pulley and belt arrangement. The compressor is lubricated by refrigerant oil that is circulated throughout the refrigerant system with the refrigerant.

The compressor draws in low-pressure refrigerant vapor from the evaporator through its suction port. It then compresses the refrigerant into a high-pressure, high-temperature refrigerant vapor, which is then pumped to the condenser through the compressor discharge port.

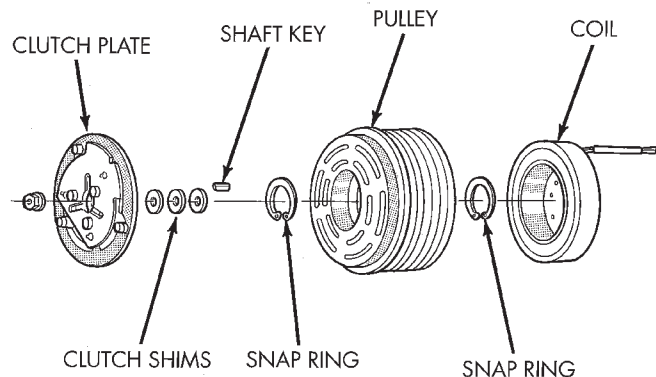
The compressor cannot be repaired. If faulty or damaged, the entire compressor assembly must be replaced. The compressor clutch, pulley and clutch coil are available for service.

COMPRESSOR CLUTCH

The compressor clutch is controlled by several components: the A/C compressor switch on the heater-A/C control panel, the ATC controller, the low pressure cycling clutch switch, the high pressure cut-off switch, the compressor clutch relay, and the Powertrain Control Module (PCM). The PCM may delay compressor clutch engagement for up to thirty seconds. Refer to Group 14 - Fuel System for more information on the PCM controls.

GASOLINE ENGINE

The compressor clutch assembly consists of a stationary electromagnetic coil, a hub bearing and pulley assembly, and a clutch plate (Fig. 3). The electromagnetic coil and pulley are retained on the compressor with snap rings. The clutch plate is mounted on the compressor shaft and secured with a bolt.



J9524-33

Fig. 3 Compressor Clutch - Gasoline Engine

These components provide the means to engage and disengage the compressor from the engine serpentine accessory drive belt. When the clutch coil is energized, it magnetically draws the clutch into contact with the pulley and drives the compressor shaft. When the coil is not energized, the pulley freewheels on the clutch hub bearing, which is part of the pulley. The compressor clutch and coil are the only serviced parts on the compressor.

DIESEL ENGINE

The compressor clutch assembly consists of a stationary electromagnetic coil, a hub bearing and rotor assembly, and a clutch plate (Fig. 4). The electromagnetic coil and rotor are retained on the compressor with snap rings. The clutch plate is mounted on the compressor shaft and secured with a bolt.

The compressor is mounted on the left side of the engine block behind the power steering pump. The compressor is driven by a splined shaft off the rear of the power steering pump. The splined shaft has a

DESCRIPTION AND OPERATION (Continued)

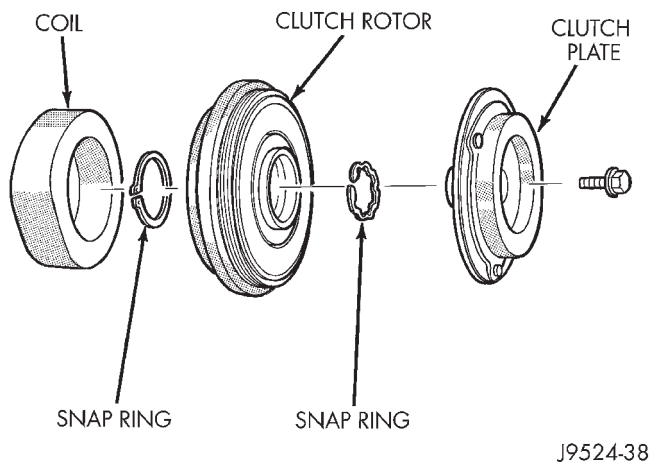


Fig. 4 Compressor Clutch - Diesel Engine

drive flange mounted to it which attaches to a drive spool. The spool links the compressor clutch plate to the steering pump drive flange. When the clutch coil is energized, it magnetically draws the clutch plate into contact with the rotor and drives the compressor shaft. When the coil is not energized, the rotor free-wheels on the clutch hub bearing, which is part of the rotor. The compressor clutch and coil are the only serviced parts on the compressor.

DIAGNOSIS AND TESTING

COMPRESSOR

When investigating an air conditioning related noise, you must first know the conditions under which the noise occurs. These conditions include: weather, vehicle speed, transmission in gear or neutral, engine speed, engine temperature, and any other special conditions. Noises that develop during air conditioning operation can often be misleading. For example: What sounds like a failed front bearing or connecting rod, may be caused by loose bolts, nuts, mounting brackets, or a loose compressor clutch assembly.

Drive belts are speed sensitive. At different engine speeds and depending upon belt tension, belts can develop noises that are mistaken for a compressor noise. Improper belt tension can cause a misleading noise when the compressor clutch is engaged, which may not occur when the compressor clutch is disengaged. Check the serpentine drive belt condition and tension as described in Group 7 - Cooling System before beginning this procedure.

(1) Select a quiet area for testing. Duplicate the complaint conditions as much as possible. Switch the compressor on and off several times to clearly identify the compressor noise. Listen to the compressor while the clutch is engaged and disengaged. Probe

the compressor with an engine stethoscope or a long screwdriver with the handle held to your ear to better localize the source of the noise.

(2) Loosen all of the compressor mounting hardware and retighten. Tighten the compressor clutch mounting nut. Be certain that the clutch coil is mounted securely to the compressor, and that the clutch plate and pulley are properly aligned and have the correct air gap. See Compressor and Compressor Clutch in the Removal and Installation section of this group for the procedures.

(3) To duplicate a high-ambient temperature condition (high head pressure), restrict the air flow through the condenser. Install a manifold gauge set to be certain that the discharge pressure does not exceed 2760 kPa (400 psi).

(4) Check the refrigerant system plumbing for incorrect routing, rubbing or interference, which can cause unusual noises. Also check the refrigerant lines for kinks or sharp bends that will restrict refrigerant flow, which can cause noises. See Suction and Discharge Line in the Removal and Installation section of this group for more information.

(5) If the noise is from opening and closing of the high pressure relief valve, evacuate and recharge the refrigerant system. See Refrigerant System Evacuate and Refrigerant System Charge in the Service Procedures section of this group. If the high pressure relief valve still does not seat properly, replace the compressor.

(6) If the noise is from liquid slugging on the suction line, replace the accumulator. See Accumulator in the Removal and Installation section of this group for the procedures. Check the refrigerant oil level and the refrigerant system charge. See Refrigerant Oil Level and Refrigerant System Charge in the Service Procedures section of this group. If the liquid slugging condition continues following accumulator replacement, replace the compressor.

(7) If the noise continues, replace the compressor and repeat Step 1.

COMPRESSOR CLUTCH COIL

For circuit descriptions and diagrams, refer to 8W-42 - Air Conditioning/Heater in Group 8W - Wiring Diagrams. The battery must be fully-charged before performing the following tests. Refer to Group 8A - Battery for more information.

(1) Connect an ammeter (0 to 10 ampere scale) in series with the clutch coil terminal. Use a voltmeter (0 to 20 volt scale) with clip-type leads for measuring the voltage across the battery and the compressor clutch coil.

(2) With the heater-A/C mode control switch in any A/C mode, the heater-A/C control A/C switch in the On position, and the blower motor switch in the low-

DIAGNOSIS AND TESTING (Continued)

est speed position, start the engine and run it at normal idle.

(3) The compressor clutch coil voltage should read within two volts of the battery voltage. If there is voltage at the clutch coil, but the reading is not within two volts of the battery voltage, test the clutch coil feed circuit for excessive voltage drop and repair as required. If there is no voltage reading at the clutch coil, use a DRB scan tool and the proper Diagnostic Procedures manual for testing of the compressor clutch circuit. The following components must be checked and repaired as required before you can complete testing of the clutch coil:

- Fuses in the junction block and the Power Distribution Center (PDC)
- Heater-A/C mode control switch
- Compressor clutch relay
- High pressure cut-off switch
- Low pressure cycling clutch switch
- Powertrain Control Module (PCM).

(4) The compressor clutch coil is acceptable if the current draw measured at the clutch coil is 2.0 to 3.9 amperes with the electrical system voltage at 11.5 to 12.5 volts. This should only be checked with the work area temperature at 21° C (70° F). If system voltage is more than 12.5 volts, add electrical loads by turning on electrical accessories until the system voltage drops below 12.5 volts.

(a) If the clutch coil current reading is four amperes or more, the coil is shorted and should be replaced.

(b) If the clutch coil current reading is zero, the coil is open and should be replaced.

REMOVAL AND INSTALLATION**REFRIGERANT LINE COUPLER**

WARNING: REVIEW THE WARNINGS AND CAUTIONS IN THE GENERAL INFORMATION SECTION NEAR THE FRONT OF THIS GROUP BEFORE PERFORMING THE FOLLOWING OPERATION.

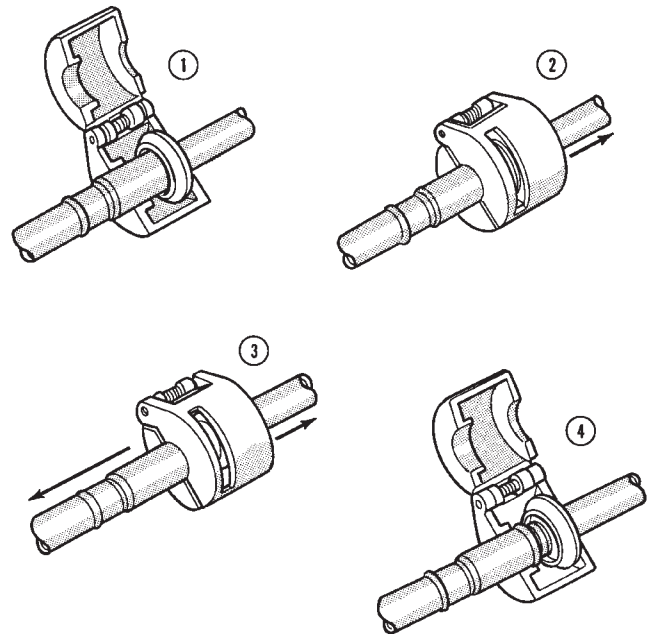
REMOVAL

(1) Recover the refrigerant from the refrigerant system. See Refrigerant Recovery in the Service Procedures section of this group.

(2) Remove the secondary clip from the spring-lock coupler.

(3) Fit the proper size A/C line disconnect tool (Special Tool Kit 7193) over the spring-lock coupler cage (Fig. 5).

(4) Close the two halves of the A/C line disconnect tool around the spring-lock coupler.



J9324-5

Fig. 5 Refrigerant Line Spring-Lock Coupler Disconnect

(5) Push the A/C line disconnect tool into the open side of the coupler cage to expand the garter spring. Once the garter spring is expanded and while still pushing the disconnect tool into the open side of the coupler cage, pull on the refrigerant line attached to the female half of the coupler fitting until the flange on the female fitting is separated from the garter spring and cage on the male fitting within the disconnect tool.

NOTE: The garter spring may not release if the A/C line disconnect tool is cocked while pushing it into the coupler cage opening.

(6) Open and remove the A/C line disconnect tool from the disconnected spring-lock coupler.

(7) Complete the separation of the two halves of the coupler fitting.

INSTALLATION

(1) Check to ensure that the garter spring is located within the cage of the male coupler fitting, and that the garter spring is not damaged.

(a) If the garter spring is missing, install a new spring by pushing it into the coupler cage opening.

(b) If the garter spring is damaged, remove it from the coupler cage with a small wire hook (DO NOT use a screwdriver) and install a new garter spring.

(2) Clean any dirt or foreign material from both halves of the coupler fitting.

(3) Install new O-rings on the male half of the coupler fitting.

REMOVAL AND INSTALLATION (Continued)

CAUTION: Use only the specified O-rings as they are made of a special material for the R-134a system. The use of any other O-rings may allow the connection to leak intermittently during vehicle operation.

(4) Lubricate the male fitting and O-rings, and the inside of the female fitting with clean R-134a refrigerant oil. Use only refrigerant oil of the type recommended for the compressor in the vehicle.

(5) Fit the female half of the coupler fitting over the male half of the fitting.

(6) Push together firmly on the two halves of the coupler fitting until the garter spring in the cage on the male half of the fitting snaps over the flanged end on the female half of the fitting.

(7) Ensure that the spring-lock coupler is fully engaged by trying to separate the two coupler halves. This is done by pulling the refrigerant lines on either side of the coupler away from each other.

(8) Reinstall the secondary clip over the spring-lock coupler cage.

COMPRESSOR**GASOLINE ENGINE**

The compressor may be removed and repositioned without disconnecting the refrigerant lines or discharging the refrigerant system on models equipped with a gasoline engine. Discharging is not necessary if servicing the compressor clutch or clutch coil, the engine, the cylinder head, or the generator.

WARNING: REVIEW THE WARNINGS AND CAUTIONS IN THE FRONT OF THIS GROUP BEFORE PERFORMING THE FOLLOWING OPERATION.

REMOVAL

(1) Disconnect and isolate the battery negative cable.

(2) Loosen and remove the serpentine drive belt. Refer to Group 7 - Cooling System for the procedures.

(3) Unplug the compressor clutch coil wire harness connector.

(4) Recover the refrigerant from the refrigerant system as described in this group.

(5) Remove the refrigerant lines from the compressor. Install plugs in, or tape over all of the open refrigerant fittings.

(6) Remove the bolts that secure the compressor to the mounting bracket, and lift the compressor from the mounting bracket.

INSTALLATION

NOTE: If a replacement compressor is being installed, be certain to check the oil level. See Refrigerant Oil Level in this group.

(1) If the compressor mounting bracket was removed, install the bracket to the engine. Tighten the mounting bolts to 27 N·m (20 ft. lbs.).

(2) Install the compressor on the mounting bracket. Tighten the bolts to 27 N·m (20 ft. lbs.).

(3) Remove the tape or plugs from all of the refrigerant fittings, and install the refrigerant lines on the compressor.

(4) Install the serpentine drive belt. Refer to Group 7 - Cooling System for the procedures.

(5) Plug in the compressor clutch coil wire harness connector.

(6) Connect the battery negative cable.

(7) Evacuate and charge the refrigerant system as described in this group.

DIESEL ENGINE

The compressor and clutch may only be removed as a unit on models equipped with a diesel engine.

WARNING: REVIEW THE WARNINGS AND CAUTIONS IN THE FRONT OF THIS GROUP BEFORE PERFORMING THE FOLLOWING OPERATION.

REMOVAL

(1) Disconnect and isolate the battery negative cable.

(2) Recover the refrigerant from the refrigerant system as described in this group.

(3) Unplug the compressor clutch coil wire harness connector.

(4) Remove the refrigerant line bracket from the engine valve cover.

(5) Remove the refrigerant lines from the compressor. Install plugs in, or tape over all of the open refrigerant fittings.

(6) Raise and support the vehicle.

(7) Remove the bolts that secure the compressor clutch drive spool to the power steering pump drive flange.

(8) Remove the four compressor mounting bolts and spacers, and remove the compressor and clutch unit from the engine block.

(9) Remove the compressor clutch and drive spool from the compressor as described in this group.

REMOVAL AND INSTALLATION (Continued)**INSTALLATION**

NOTE: If a replacement compressor is being installed, be certain to check the oil level. See Refrigerant Oil Level in this group.

- (1) Install the compressor clutch and drive spool on the compressor as described in this group.
- (2) Install the compressor on the engine block using the four mounting bolts and spacers. Tighten the bolts to 24 N·m (18 ft. lbs.).
- (3) Install the bolts that secure the compressor clutch drive spool to the power steering pump drive flange. Tighten the bolts to 16 N·m (12 ft. lbs.).
- (4) Lower the vehicle.
- (5) Remove the tape or plugs from all of the refrigerant fittings, and install the refrigerant lines on the compressor.
- (6) Install the refrigerant line bracket on the engine valve cover. Tighten the bolt to 5.6 N·m (50 in. lbs.).
- (7) Plug in the compressor clutch coil wire harness connector.
- (8) Connect the battery negative cable.
- (9) Evacuate and charge the refrigerant system as described in this group.

COMPRESSOR CLUTCH**GASOLINE ENGINE**

The refrigerant system can remain fully-charged during compressor clutch, pulley, or coil replacement on gasoline engine models. The compressor clutch can be serviced in the vehicle.

REMOVAL

- (1) Disconnect and isolate the battery negative cable.
- (2) Remove the compressor shaft bolt (Fig. 6). A band-type oil filter wrench may be used to aid in securing the clutch during bolt removal.
- (3) Tap the clutch plate with a plastic mallet to release it from the splines on the compressor shaft. Remove clutch plate and shim(s) from the compressor shaft (Fig. 7).

CAUTION: Do not pry between the clutch plate assembly and the pulley to remove the front plate. This may damage the front plate assembly.

- (4) Remove the pulley retaining snap ring with snap ring pliers (Special Tool C-4574) and slide the pulley assembly off of the compressor (Fig. 8).
- (5) Unplug the clutch coil wire harness connector. Remove the screw and retainer from the clutch coil wire harness on the compressor front housing.

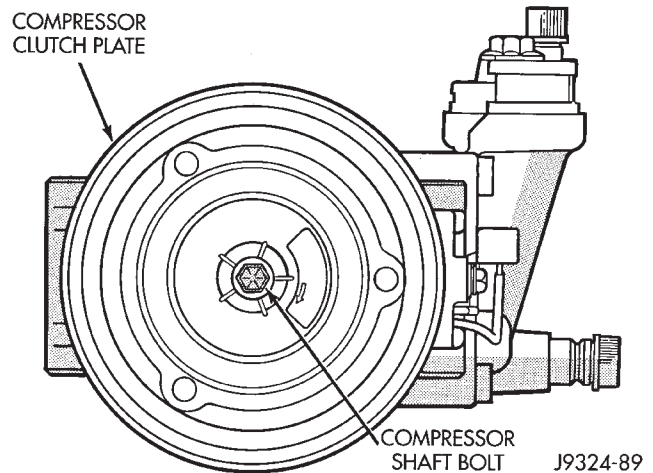


Fig. 6 Compressor Shaft Bolt

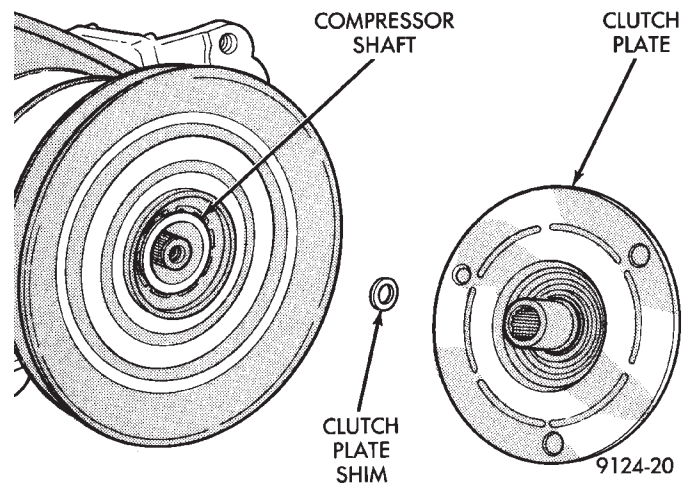


Fig. 7 Clutch Plate and Shim

- (6) Remove the snap ring from the compressor hub and remove the clutch field coil (Fig. 9). Slide the clutch field coil off of the compressor hub.

INSPECTION

Examine the friction surfaces of the clutch pulley and the front plate for wear. The pulley and front plate should be replaced if there is excessive wear or scoring.

If the friction surfaces are oily, inspect the shaft and nose area of the compressor for oil. Remove the felt from the front cover. If the felt is saturated with oil, the shaft seal is leaking and the compressor must be replaced.

Check the clutch pulley bearing for roughness or excessive leakage of grease. Replace the bearing, if required.

REMOVAL AND INSTALLATION (Continued)

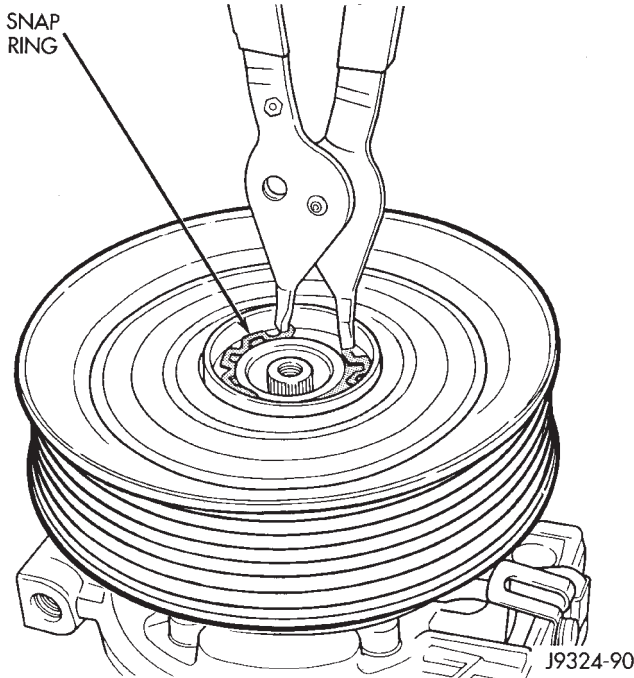


Fig. 8 Pulley Snap Ring Remove/Install

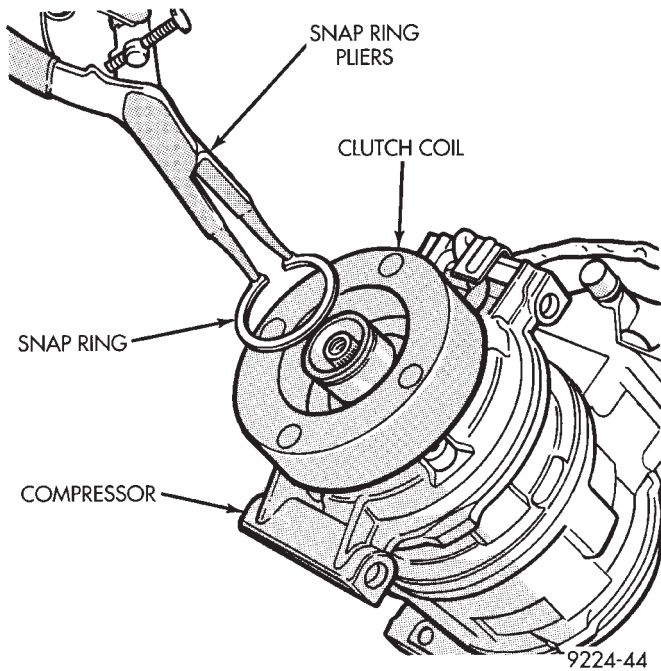


Fig. 9 Clutch Coil Snap Ring Remove/Install

INSTALLATION

(1) Align the dowel pin on the back of the clutch field coil with the hole in the compressor front housing and press the field coil into place.

(2) Install the clutch coil wire harness retaining clip on the compressor front housing and tighten the retaining screw. Plug in the clutch coil wire harness connector.

(3) Install the clutch field coil and snap ring with snap ring pliers (Special Tool C-4574). The bevel side of the snap ring must be facing outward. Also, both eyelets of the snap ring must be to the right or left of the pin on the compressor. Press the snap ring to make sure it is properly seated in the groove.

CAUTION: If the snap ring is not fully seated in the groove it will vibrate out, resulting in a clutch failure and severe damage to the front housing of the compressor.

(4) Install the pulley assembly onto the compressor. If necessary, place a block of wood on the friction surface and tap gently with a hammer (Fig. 10).

CAUTION: Do not mar the pulley friction surface.

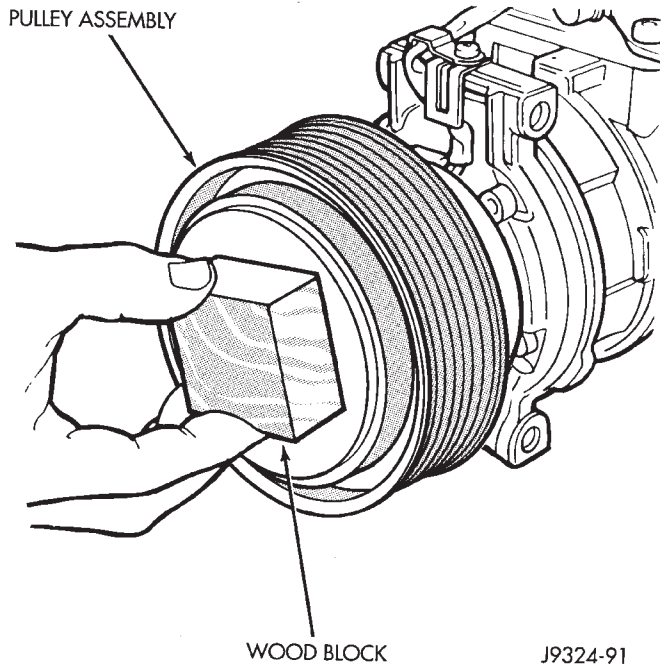


Fig. 10 Pulley Assembly Install

(5) Install the pulley assembly retaining snap ring (bevel side outward) with snap ring pliers (Special Tool C-4574). Press the snap ring to make sure it is properly seated in the groove.

(6) If the original front plate assembly and pulley assembly are to be reused, the old shim(s) can be used. If not, place a stack of shim(s) equal to the old shim(s) on the shaft against the shoulder.

(7) Install the front plate assembly onto the shaft.

(8) With the front plate assembly tight against the shim(s), measure the air gap between the front plate and the pulley face with feeler gauges. The air gap should be 0.35 to 0.65 mm (0.014 to 0.026 in.). If the proper air gap is not obtained, add or subtract shims as needed until the desired air gap is obtained.

REMOVAL AND INSTALLATION (Continued)

(9) Install the compressor shaft bolt. Tighten the bolt to 13 N·m (115 in. lbs.).

NOTE: The shims may compress after tightening the shaft bolt. Check the air gap in four or more places to verify the air gap is still correct. Spin the pulley before performing a final check of the air gap.

(10) Connect the battery negative cable.

CLUTCH BREAK-IN

After a new compressor clutch has been installed, cycle the compressor clutch approximately twenty times (five seconds on, then five seconds off). During this procedure, set the heater-A/C control to the A/C (Recirc) mode, the blower motor switch in the highest speed position, and the engine speed at 1500 to 2000 rpm. This procedure (burnishing) will seat the opposing friction surfaces and provide a higher compressor clutch torque capability.

DIESEL ENGINE

The refrigerant must be recovered from the refrigerant system during compressor clutch, drive, or coil replacement on diesel engine models. The compressor clutch cannot be serviced in the vehicle.

REMOVAL

(1) Remove the compressor and clutch from the vehicle as described in this group.

(2) Mount the compressor in a vise and remove the bolts that secure the drive spool to the drive plate.

(3) Remove the compressor drive plate with a spanner wrench (Special Tool 3281). Turn the drive plate counterclockwise to remove (Fig. 11).

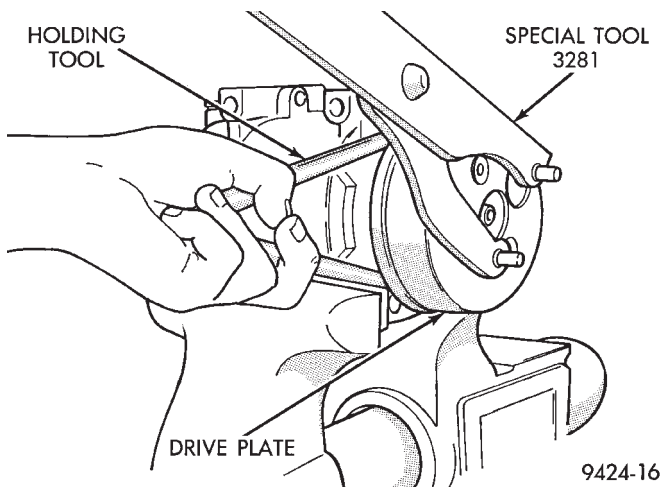


Fig. 11 Drive Plate Remove

(4) Insert the two pins of the spanner wrench into two holes of the clutch plate. Hold the clutch plate

stationary and remove the bolt that secures the clutch plate to the compressor shaft.

(5) Remove the clutch plate (Fig. 12).

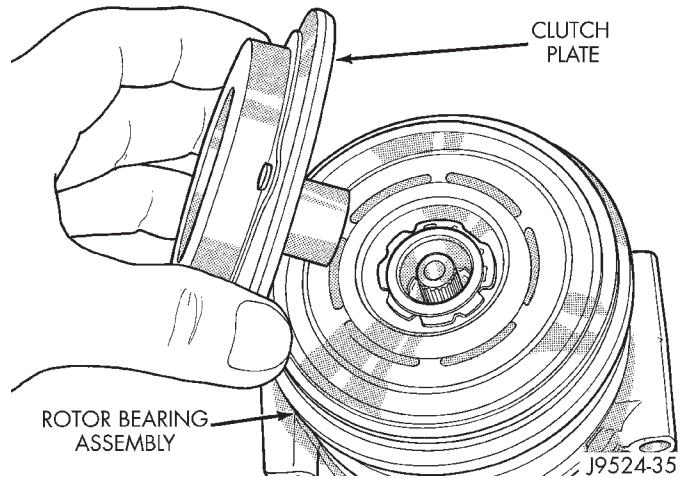


Fig. 12 Clutch Plate Remove/Install

(6) Remove the external snap ring from the front compressor housing hub with snap ring pliers and remove the clutch rotor and bearing assembly (Fig. 13).

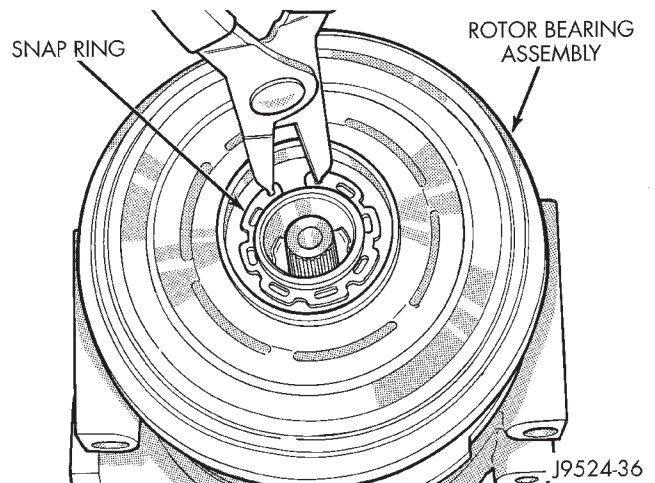


Fig. 13 External Snap Ring Remove/Install

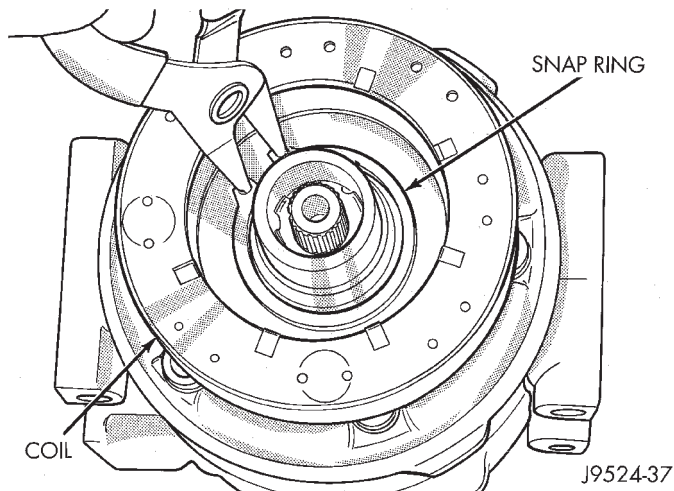
(7) Remove the screw and retainer from the clutch coil wire harness on the compressor front housing.

(8) Remove the snap ring from the compressor hub and remove the clutch field coil (Fig. 14). Slide the clutch field coil off of the compressor hub.

INSPECTION

Examine the friction surfaces of the clutch drive plate and the clutch plate for wear. The drive plate and clutch plate should be replaced if there is excessive wear or scoring.

If the friction surfaces are oily, inspect the shaft and nose area of the compressor for oil. Remove the felt from the front cover. If the felt is saturated with

REMOVAL AND INSTALLATION (Continued)**Fig. 14 Clutch Coil Snap Ring Remove/Install**

oil, the shaft seal is leaking and the compressor must be replaced.

Check the clutch drive plate bearing for roughness or excessive leakage of grease. Replace the bearing, if required.

INSTALLATION

(1) Align the dowel pin on the back of the clutch field coil with the hole in the compressor front housing and press the field coil into place.

(2) Install the clutch coil wire lead retaining clip on the compressor front housing and tighten the retaining screw.

(3) Install the clutch field coil and snap ring with snap ring pliers. The bevel side of the snap ring must be facing outward. Press the snap ring to make sure it is properly seated in the groove.

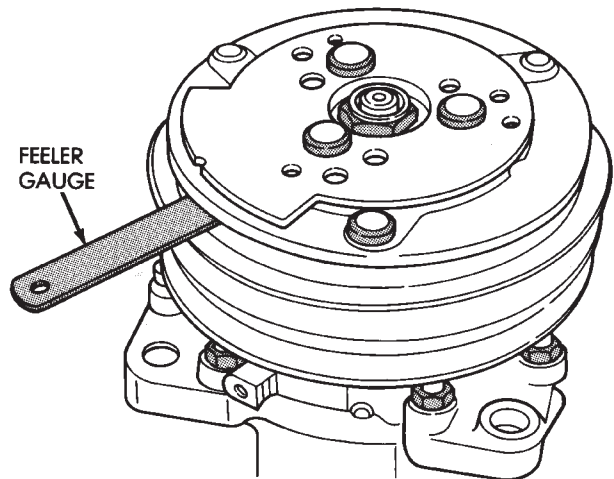
CAUTION: If the snap ring is not fully seated in the groove it will vibrate out, resulting in a clutch failure and severe damage to the front housing of the compressor.

(4) Check that the original clutch spacer shims are in place on the compressor shaft and install the clutch plate. Replace the shaft bolt and tighten to 14.4 N·m (10.5 ft. lbs.).

NOTE: The clutch air gap is determined by the spacer shims. When installing the original or a new clutch assembly, try the original shims first. When installing a new clutch onto a compressor that pre-

viously did not have a clutch, use 0.040, 0.020, and 0.005 in. shims from the clutch accessory sack.

(5) Check the air gap with a feeler gauge (Fig. 15). If the air gap does not meet the specification add or subtract shims as required. The specification is 0.41 to 0.79 mm (0.016 to 0.031 inch). If the air gap is not consistent around the circumference, lightly pry up at the points of minimum variation. Lightly tap down at the points of maximum variation.



J8924-28

Fig. 15 Check Air Gap

(6) Install the drive plate onto the clutch and tighten to 98 N·m (72 ft. lbs.).

(7) Install the drive spool onto the drive plate. Tighten the drive spool bolts to 16 N·m (12 ft. lbs.).

(8) Reverse the remaining removal procedures to complete the installation.

CLUTCH BREAK-IN

After a new compressor clutch has been installed, cycle the compressor clutch approximately twenty times (five seconds on, then five seconds off). During this procedure, set the heater-A/C control to the A/C (Recirc) mode, the blower motor switch in the highest speed position, and the engine speed at 1500 to 2000 rpm. This procedure (burnishing) will seat the opposing friction surfaces and provide a higher compressor clutch torque capability.

EMISSION CONTROL SYSTEMS

CONTENTS

	page
EVAPORATIVE EMISSION CONTROLS	12
ON-BOARD DIAGNOSTICS	1

ON-BOARD DIAGNOSTICS

INDEX

	page
GENERAL INFORMATION	
SYSTEM DESCRIPTION	1
DESCRIPTION AND OPERATION	
CIRCUIT ACTUATION TEST MODE	2
COMPONENT MONITORS	10
DIAGNOSTIC TROUBLE CODES	2
HIGH AND LOW LIMITS	11
LOAD VALUE	11
MALFUNCTION INDICATOR LAMP (MIL)	2
MONITORED SYSTEMS	7
NON-MONITORED CIRCUITS	10
STATE DISPLAY TEST MODE	2
TRIP DEFINITION	10

GENERAL INFORMATION

SYSTEM DESCRIPTION

The Powertrain Control Module (PCM) monitors many different circuits in the fuel injection, ignition, emission and engine systems. If the PCM senses a problem with a monitored circuit often enough to indicate an actual problem, it stores a Diagnostic Trouble Code (DTC) in the PCM's memory. If the code applies to a non-emissions related component or system, and the problem is repaired or ceases to exist, the PCM cancels the code after 40 warm-up cycles. Diagnostic trouble codes that affect vehicle emissions illuminate the Malfunction Indicator (check engine) Lamp. Refer to Malfunction Indicator Lamp in this section.

Certain criteria must be met before the PCM stores a DTC in memory. The criteria may be a specific range of engine RPM, engine temperature, and/or input voltage to the PCM.

The PCM might not store a DTC for a monitored circuit even though a malfunction has occurred. This may happen because one of the DTC criteria for the circuit has not been met. **For example**, assume the diagnostic trouble code criteria requires the PCM to monitor the circuit only when the engine operates between 750 and 2000 RPM. Suppose the sensor's output circuit shorts to ground when engine operates above 2400 RPM (resulting in 0 volt input to the PCM). Because the condition happens at an engine speed above the maximum threshold (2000 rpm), the PCM will not store a DTC.

There are several operating conditions for which the PCM monitors and sets DTC's. Refer to Monitored Systems, Components, and Non-Monitored Circuits in this section.

Technicians must retrieve stored DTC's by connecting the DRB scan tool (or an equivalent scan tool) to the 16-way data link connector (Fig. 1). Refer to Diagnostic Trouble Codes in this section.



GENERAL INFORMATION (Continued)

NOTE: Various diagnostic procedures may actually cause a diagnostic monitor to set a DTC. For instance, pulling a spark plug wire to perform a spark test may set the misfire code. When a repair is completed and verified, connect the DRB scan tool to the 16-way data link connector to erase all DTC's and extinguish the MIL (check engine lamp).

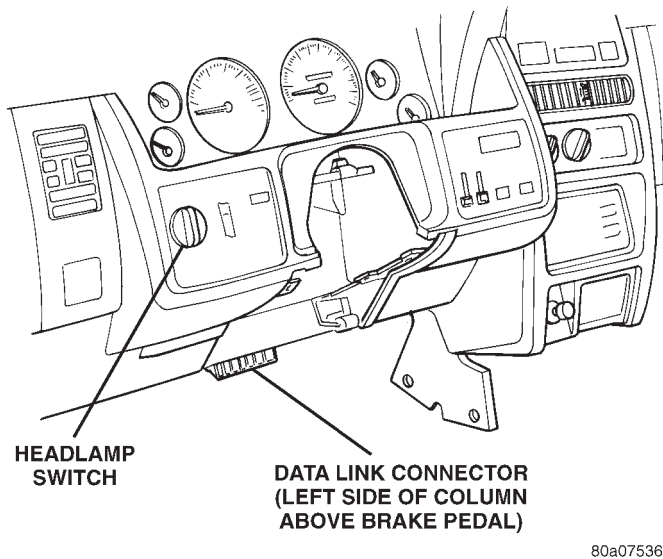


Fig. 1 Data Link (Diagnostic) Connector Location

DESCRIPTION AND OPERATION

MALFUNCTION INDICATOR LAMP (MIL)

As a functional test, the MIL (check engine) illuminates at key-on before engine cranking. Whenever the Powertrain Control Module (PCM) sets a Diagnostic Trouble Code (DTC) that affects vehicle emissions, it illuminates the MIL. If a problem is detected, the PCM sends a message to the instrument cluster to illuminate the lamp. The PCM illuminates the MIL only for DTC's that affect vehicle emissions. There are some monitors that may take two consecutive trips, with a detected fault, before the MIL is illuminated. The MIL stays on continuously when the PCM has entered a Limp-In mode or identified a failed emission component. Refer to the Diagnostic Trouble Code charts in this group for emission related codes.

Also, the MIL either flashes or illuminates continuously when the PCM detects active engine misfire. Refer to Misfire Monitoring in this section.

Additionally, the PCM may reset (turn off) the MIL when one of the following occur:

- PCM does not detect the malfunction for 3 consecutive trips (except misfire and Fuel system Monitors).
- PCM does not detect a malfunction while performing three successive engine misfire or fuel system tests. The PCM performs these tests while the

engine is operating within ± 375 RPM of and within 10 % of the load of the operating condition at which the malfunction was first detected.

STATE DISPLAY TEST MODE

The switch inputs to the Powertrain Control Module (PCM) have two recognized states; HIGH and LOW. For this reason, the PCM cannot recognize the difference between a selected switch position versus an open circuit, a short circuit, or a defective switch. If the State Display screen shows the change from HIGH to LOW or LOW to HIGH, assume the entire switch circuit to the PCM functions properly. Connect the DRB scan tool to the data link connector and access the state display screen. Then access either State Display Inputs and Outputs or State Display Sensors.

CIRCUIT ACTUATION TEST MODE

The Circuit Actuation Test Mode checks for proper operation of output circuits or devices the Powertrain Control Module (PCM) may not internally recognize. The PCM attempts to activate these outputs and allow an observer to verify proper operation. Most of the tests provide an audible or visual indication of device operation (click of relay contacts, fuel spray, etc.). Except for intermittent conditions, if a device functions properly during testing, assume the device, its associated wiring, and driver circuit work correctly. Connect the DRB scan tool to the data link connector and access the Actuators screen.

DIAGNOSTIC TROUBLE CODES

A Diagnostic Trouble Code (DTC) indicates the PCM has recognized an abnormal condition in the system.

Diagnostic trouble codes are the results of a system or circuit failure, but do not directly identify the failed component or components.

Technicians must retrieve stored DTC's by connecting the DRB scan tool (or an equivalent scan tool) to the 16-way data link connector (Fig. 1).

NOTE: For a list of DTC's, refer to the charts in this section.

OBTAINING DIAGNOSTIC TROUBLE CODES

WARNING: APPLY PARKING BRAKE AND/OR BLOCK WHEELS BEFORE PERFORMING ANY TEST ON AN OPERATING ENGINE.

- (1) Connect the DRB scan tool to data link (diagnostic) connector.
- (2) Turn the ignition switch on, access Read Fault Screen. Record all the DTC's shown on the DRB scan tool.
- (3) To erase DTC's, use the Erase Trouble Code data screen on the DRB scan tool.

DESCRIPTION AND OPERATION (Continued)

DIAGNOSTIC TROUBLE CODE DESCRIPTIONS

* Check Engine Lamp (MIL) will illuminate during engine operation if this Diagnostic Trouble Code was recorded.

Hex Code	Generic Scan Tool Code	DRB Scan Tool Display	Description of Diagnostic Trouble Code
00			DTC Error
*01	P0340	No Cam Signal at PCM	No camshaft signal detected during engine cranking.
*02	P0601	Internal Controller Failure	PCM Internal fault condition detected.
05	P0162	Charging System Voltage Too Low	Battery voltage sense input below target charging during engine operation. Also, no significant change detected in battery voltage during active test of generator output circuit.
06	P1594	Charging System Voltage Too High	Battery voltage sense input above target charging voltage during engine operation.
0A	P1388	Auto Shutdown Relay Control Circuit	An open or shorted condition detected in the auto shutdown relay circuit.
0B	P0622	Generator Field Not Switching Properly	An open or shorted condition detected in the generator field control circuit.
*0C	P0743	Torque Converter Clutch Solenoid/Trans Relay Circuits	An open or shorted condition detected in the torque converter part throttle unlock solenoid control circuit (3 speed auto RH trans. only).
0F	P1595	Speed Control Solenoid Circuits	An open or shorted condition detected in the Speed Control vacuum or vent solenoid circuits.
10	P0645	A/C Clutch Relay Circuit	An open or shorted condition detected in the A/C clutch relay circuit.
*12	P0443	EVAP Purge Solenoid Circuit	An open or shorted condition detected in the duty cycle purge solenoid circuit.
*13	P0203	Injector #3 Control Circuit	Injector #3 output driver does not respond properly to the control signal.
*14	or P0202	Injector #2 Control Circuit	Injector #2 output driver does not respond properly to the control signal.
*15	or P0201	Injector #1 Control Circuit	Injector #1 output driver does not respond properly to the control signal.
*19	P0505	Idle Air Control Motor Circuits	A shorted or open condition detected in one or more of the idle air control motor circuits.
*1A	P0122	Throttle Position Sensor Voltage Low	Throttle position sensor input below the minimum acceptable voltage
*1B	or P0123	Throttle Position Sensor Voltage High	Throttle position sensor input above the maximum acceptable voltage.

DESCRIPTION AND OPERATION (Continued)

Hex Code	Generic Scan Tool Code	DRB Scan Tool Display	Description of Diagnostic Trouble Code
*1E	P0117	ECT Sensor Voltage Too Low	Engine coolant temperature sensor input below minimum acceptable voltage.
*1F	or P0118	ECT Sensor Voltage Too High	Engine coolant temperature sensor input above maximum acceptable voltage.
21	P1281	Engine Is Cold Too Long	Engine did not reach operating temperature within acceptable limits.
*23	P0500	No Vehicle Speed Sensor Signal	No vehicle speed sensor signal detected during road load conditions.
*24	P0107	MAP Sensor Voltage Too Low	MAP sensor input below minimum acceptable voltage.
*25	or P0108	MAP Sensor Voltage Too High	MAP sensor input above maximum acceptable voltage.
*27	P1297	No Change in MAP From Start to Run	No difference recognized between the engine MAP reading and the barometric (atmospheric) pressure reading from start-up.
28	P0320	No Crank Reference Signal at PCM	No crank reference signal detected during engine cranking.
2B	P0351	Ignition Coil #1 Primary Circuit	Peak primary circuit current not achieved with maximum dwell time.
*2C	P1389	No ASD Relay Output Voltage at PCM	An Open condition Detected In The ASD Relay Output Circuit.
31	P1696	PCM Failure EEPROM Write Denied	Unsuccessful attempt to write to an EEPROM location by the PCM.
*32	P0753	Trans 3-4 Shift Sol/Trans Relay Circuits	Current state of output port for the solenoid is different from expected state.
*39	P0112	Intake Air Temp Sensor Voltage Low	Intake air temperature sensor input below the maximum acceptable voltage.
*3A	or P0113	Intake Air Temp Sensor Voltage High	Intake air temperature sensor input above the minimum acceptable voltage.
*3D	P0204	Injector #4 Control Circuit	Injector #4 output driver does not respond properly to the control signal.
*3E	P0132	Left Upstream O2S Shorted to Voltage	Oxygen sensor input voltage maintained above the normal operating range.
44	PO600	PCM Failure SPI Communications	PCM internal fault condition detected
*45	P0205	Injector #5 Control Circuit	Injector #5 output driver does not respond properly to the control signal.
*46	or P0206	Injector #6 Control Circuit	Injector #6 output driver does not respond properly to the control signal.

DESCRIPTION AND OPERATION (Continued)

Hex Code	Generic Scan Tool Code	DRB Scan Tool Display	Description of Diagnostic Trouble Code
4A	P0712	Trans Temp Sensor Voltage Too Low	Voltage less than 1.55 volts.
4B	P0713	Trans Temp Sensor Voltage Too High	Voltage greater than 3.76 volts.
*4F	P0207	Injector #7 Control Circuit	Injector #7 output driver does not respond properly to the control signal.
*50	P0208	Injector #8 Control Circuit	Injector #8 output driver does not respond properly to the control signal.
52	P1683	S/C Power Ckt	Malfunction detected with power feed to speed control servo solenoids
56	P1596	Speed Control Switch Always High	Speed control switch input above the maximum acceptable voltage.
57	P1597	Speed Control Switch Always Low	Speed control switch input below the minimum acceptable voltage.
65	P1282	Fuel Pump Relay Control Circuit	An open or shorted condition detected in the fuel pump relay control circuit.
*66	P0133 or P0152	Left Upstream O2S Slow Response	Oxygen sensor response slower than minimum required switching frequency.
*67	P0135	Left Upstream O2S Heater Failure	Upstream oxygen sensor heating element circuit malfunction
*69	P0141	Downstream, Left Bank Downstream or Pre-Catalyst Heater Failure	Oxygen sensor heating element circuit malfunction.
*6A	P0300	Multiple Cylinder Mis-fire	Misfire detected in multiple cylinders.
*6B	P0301	Cylinder #1 Mis-fire	Misfire detected in cylinder #1.
*6C	P0302	Cylinder #2 Mis-fire	Misfire detected in cylinder #2.
*6D	P0303	Cylinder #3 Mis-fire	Misfire detected in cylinder #3.
*6E	P0304	Cylinder #4 Mis-fire	Misfire detected in cylinder #4.
*70	P0420	Left Bank Catalytic (or just) Catalytic Efficiency Failure	Catalyst efficiency below required level.
*71	P0441	Evap Purge Flow Monitor Failure	Insufficient or excessive vapor flow detected during evaporative emission system operation.
*72	P1899	P/N Switch Stuck in Park or in Gear	Incorrect input state detected for the Park/ Neutral switch, auto. trans. only.
*76	P0172	Left Bank or Fuel System Rich	A rich air/fuel mixture has been indicated by an abnormally lean correction factor.
*77	P0171	Right Rear (or just) Fuel System Lean	A lean air/fuel mixture has been indicated by an abnormally rich correction factor.

DESCRIPTION AND OPERATION (Continued)

Hex Code	Generic Scan Tool Code	DRB Scan Tool Display	Description of Diagnostic Trouble Code
*7E	P0138	Left Bank Downstream or Downstream and Pre-Catalyst O2S Shorted to Voltage	Oxygen sensor input voltage maintained above the normal operating range.
*80	P0125	Closed Loop Temp Not Reached	Engine does not reach 20°F within 5 minutes with a vehicle speed signal.
*84	P0121	TPS Voltage Does Not Agree With MAP	TPS signal does not correlate to MAP sensor
*87	P1296	No 5 Volts To MAP Sensor	5 Volt output to MAP sensor open.
*8A	P1294	Target Idle Not Reached	Actual idle speed does not equal target idle speed.
*8D	P1756	Governor Pressure Not Equal to Target @ 15-20 PSI	Governor sensor input not between 10 and 25 psi when requested.
*8E	P1757	Governor Pressure Above 3 PSI In Gear With 0 MPH	Governor pressure greater than 3 psi when requested to be 0 psi.
*94	P0740	Torq Conv Clu, No RPM Drop At Lockup	Relationship between engine speed and vehicle speed indicates no torque converter clutch engagement (auto. trans. only).
95	P0462	Fuel Level Sending Unit Volts Too Low	Open circuit between PCM and fuel gauge sending unit.
96	P0463	Fuel Level Sending Unit Volts Too High	Circuit shorted to voltage between PCM and fuel gauge sending unit.
97	P0460	Fuel Level Unit No Change Over Miles	No movement of fuel level sender detected.
*99	P1493	Ambient/Batt Temp Sen Volts Too Low	Battery temperature sensor input voltage below an acceptable range.
*9A	P1492	Ambient/Batt Temp Sensor Volts Too High	Battery temperature sensor input voltage above an acceptable range.
*9B	P0131	Left Bank and Upstream O2S Shorted to Ground	O2 sensor voltage too low, tested after cold start.
*9C	P0137	Downstream, Left Bank Downstream and Pre-Catalyst O2S Shorted to Ground	O2 sensor voltage too low, tested after cold start.
*9D	P1391	Intermittent Loss of CMP or CKP	Intermittent loss of either camshaft or crankshaft position sensor
*A0	P0442	Evap Leak Monitor Small Leak Detected	A small leak has been detected by the leak detection monitor
*A1	P0455	Evap Leak Monitor Large Leak Detected	The leak detection monitor is unable to pressurize Evap system, indicating a large leak.
A4	P0711	Trans Temp Sensor, No Rise After Start	Sump temp did not rise more than 16°F within 10 minutes when starting temp is below 40°F or sump temp is above 260°F with coolant below 100°F.

DESCRIPTION AND OPERATION (Continued)

Hex Code	Generic Scan Tool Code	DRB Scan Tool Display	Description of Diagnostic Trouble Code
*A5	P0783	3-4 Shift Sol, No RPM Drop @ 3-4 Shift	The ratio of engine rpm/output shaft speed did not change beyond on the minimum required.
*A6	P0720	Low Ouput Spd Sensor RPM Above 15 mph	Output shaft speed is less than 60 rpm with vehicle speed above 15 mph.
*A7	P1764	Governor Pessure Sensor Volts Too Low	Voltage less than .10 volts.
*A8	P1763	Governor Pressure Sensor Volts Too HI	Voltage greater than 4.89 volts.
*A9	P1762	Governor Press Sen Offset Volts Too Lo or High	Sensor input greater or less than calibration for 3 consecutive Neutral/Park occurances.
*AB	P0748	Governor Pressure Sol Control/Trans Relay Circuits	Current state of solenoid output port is different than expected.
*AD	P1765	Trans 12 Volt Supply Relay Ctrl Circuit	Current state of solenoid output port is different than expeted.
*AE	P0305	Cylinder #5 Mis-fire	Misfire detected in cylinder #5.
*AF	P0306	Cylinder #6 Mis-fire	Misfire detected in cylinder #6.
*B0	P0307	Cylinder #7 Mis-fire	Misfire detected in cylinder #7.
*B1	P0308	Cylinder #8 Mis-fire	Misfire detected in cylinder #8.
*B7	P1495	Leak Detection Pump Solenoid Circuit	Leak detection pump solenoid circuit fault (open or short)
*B8	P1494	Leak detection pump SW or mechanical fault	Leak detection pump switch does not respond to input.
*BA	P1398	No Crank Sensr Learn	CKP sensor target windows have too much variation
*BB	P1486	Evap leak monitor pinched hose found	Plug or pinch detected between purge solenoid and fuel tank
BC	P0751	O/D Switch Pressed (LO) More Than 5 Min	Overdrive Off switch input too low for more than 5 minutes.
*CO	P0133 or P1195	Cat mon slow O2 1/1	A slow switching oxygen sensor has been detected in bank 1/1 during catalyst monitor test.
*C2	P0129 or P1197	Cat mon slow O2 1/2	A slow switching oxygen sensor has been detected in bank 1/2 during catalyst monitor test.

MONITORED SYSTEMS

There are new electronic circuit monitors that check fuel, emission, engine and ignition performance. These monitors use information from various sensor circuits to indicate the overall operation of the

fuel, engine, ignition and emission systems and thus the emissions performance of the vehicle.

The fuel, engine, ignition and emission systems monitors do not indicate a specific component problem. They do indicate that there is an implied prob-

DESCRIPTION AND OPERATION (Continued)

lem within one of the systems and that a specific problem must be diagnosed.

If any of these monitors detect a problem affecting vehicle emissions, the Malfunction Indicator (Check Engine) Lamp will be illuminated. These monitors generate Diagnostic Trouble Codes that can be displayed with the check engine lamp or a scan tool.

The following is a list of the system monitors:

- Misfire Monitor
- Fuel System Monitor
- Oxygen Sensor Monitor
- Oxygen Sensor Heater Monitor
- Catalyst Monitor
- Leak Detection Pump Monitor (if equipped)

All these system monitors require two consecutive trips with the malfunction present to set a fault.

Refer to the appropriate Powertrain Diagnostics Procedures manual for diagnostic procedures.

The following is an operation and description of each system monitor:

OXYGEN SENSOR (O2S) MONITOR

Effective control of exhaust emissions is achieved by an oxygen feedback system. The most important element of the feedback system is the O2S. The O2S is located in the exhaust path. Once it reaches operating temperature 300° to 350°C (572° to 662°F), the sensor generates a voltage that is inversely proportional to the amount of oxygen in the exhaust. The information obtained by the sensor is used to calculate the fuel injector pulse width. This maintains a 14.7 to 1 Air Fuel (A/F) ratio. At this mixture ratio, the catalyst works best to remove hydrocarbons (HC), carbon monoxide (CO) and nitrogen oxide (NOx) from the exhaust.

The O2S is also the main sensing element for the Catalyst and Fuel Monitors.

The O2S can fail in any or all of the following manners:

- slow response rate
- reduced output voltage
- dynamic shift
- shorted or open circuits

Response rate is the time required for the sensor to switch from lean to rich once it is exposed to a richer than optimum A/F mixture or vice versa. As the sensor starts malfunctioning, it could take longer to detect the changes in the oxygen content of the exhaust gas.

The output voltage of the O2S ranges from 0 to 1 volt. A good sensor can easily generate any output voltage in this range as it is exposed to different concentrations of oxygen. To detect a shift in the A/F mixture (lean or rich), the output voltage has to change beyond a threshold value. A malfunctioning

sensor could have difficulty changing beyond the threshold value.

OXYGEN SENSOR HEATER MONITOR

If there is an oxygen sensor (O2S) shorted to voltage DTC, as well as a O2S heater DTC, the O2S fault **MUST** be repaired first. Before checking the O2S fault, verify that the heater circuit is operating correctly.

Effective control of exhaust emissions is achieved by an oxygen feedback system. The most important element of the feedback system is the O2S. The O2S is located in the exhaust path. Once it reaches operating temperature 300° to 350°C (572° to 662°F), the sensor generates a voltage that is inversely proportional to the amount of oxygen in the exhaust. The information obtained by the sensor is used to calculate the fuel injector pulse width. This maintains a 14.7 to 1 Air Fuel (A/F) ratio. At this mixture ratio, the catalyst works best to remove hydrocarbons (HC), carbon monoxide (CO) and nitrogen oxide (NOx) from the exhaust.

The voltage readings taken from the O2S sensor are very temperature sensitive. The readings are not accurate below 300°C. Heating of the O2S sensor is done to allow the engine controller to shift to closed loop control as soon as possible. The heating element used to heat the O2S sensor must be tested to ensure that it is heating the sensor properly.

The O2S sensor circuit is monitored for a drop in voltage. The sensor output is used to test the heater by isolating the effect of the heater element on the O2S sensor output voltage from the other effects.

LEAK DETECTION PUMP MONITOR (IF EQUIPPED)

The leak detection assembly incorporates two primary functions: it must detect a leak in the evaporative system and seal the evaporative system so the leak detection test can be run.

The primary components within the assembly are: A three port solenoid that activates both of the functions listed above; a pump which contains a switch, two check valves and a spring/diaphragm, a canister vent valve (CVV) seal which contains a spring loaded vent seal valve.

Immediately after a cold start, between predetermined temperature thresholds limits, the three port solenoid is briefly energized. This initializes the pump by drawing air into the pump cavity and also closes the vent seal. During non test conditions the vent seal is held open by the pump diaphragm assembly which pushes it open at the full travel position. The vent seal will remain closed while the pump is cycling due to the reed switch triggering of the three port solenoid that prevents the diaphragm assembly from reaching full travel. After the brief

DESCRIPTION AND OPERATION (Continued)

initialization period, the solenoid is de-energized allowing atmospheric pressure to enter the pump cavity, thus permitting the spring to drive the diaphragm which forces air out of the pump cavity and into the vent system. When the solenoid is energized and de energized, the cycle is repeated creating flow in typical diaphragm pump fashion. The pump is controlled in 2 modes:

Pump Mode: The pump is cycled at a fixed rate to achieve a rapid pressure build in order to shorten the overall test length.

Test Mode: The solenoid is energized with a fixed duration pulse. Subsequent fixed pulses occur when the diaphragm reaches the Switch closure point.

The spring in the pump is set so that the system will achieve an equalized pressure of about 7.5" H₂O. The cycle rate of pump strokes is quite rapid as the system begins to pump up to this pressure. As the pressure increases, the cycle rate starts to drop off. If there is no leak in the system, the pump would eventually stop pumping at the equalized pressure. If there is a leak, it will continue to pump at a rate representative of the flow characteristic of the size of the leak. From this information we can determine if the leak is larger than the required detection limit (currently set at .040" orifice by CARB). If a leak is revealed during the leak test portion of the test, the test is terminated at the end of the test mode and no further system checks will be performed.

After passing the leak detection phase of the test, system pressure is maintained by turning on the LDP's solenoid until the purge system is activated. Purge activation in effect creates a leak. The cycle rate is again interrogated and when it increases due to the flow through the purge system, the leak check portion of the diagnostic is complete.

The canister vent valve will unseal the system after completion of the test sequence as the pump diaphragm assembly moves to the full travel position.

Evaporative system functionality will be verified by using the stricter evap purge flow monitor. At an appropriate warm idle the LDP will be energized to seal the canister vent. The purge flow will be clocked up from some small value in an attempt to see a shift in the O₂ control system. If fuel vapor, indicated by a shift in the O₂ control, is present the test is passed. If not, it is assumed that the purge system is not functioning in some respect. The LDP is again turned off and the test is ended.

MISFIRE MONITOR

Excessive engine misfire results in increased catalyst temperature and causes an increase in HC emissions. Severe misfires could cause catalyst damage. To prevent catalytic convertor damage, the PCM monitors engine misfire.

The Powertrain Control Module (PCM) monitors for misfire during most engine operating conditions (positive torque) by looking at changes in the crankshaft speed. If a misfire occurs the speed of the crankshaft will vary more than normal.

FUEL SYSTEM MONITOR

To comply with clean air regulations, vehicles are equipped with catalytic converters. These converters reduce the emission of hydrocarbons, oxides of nitrogen and carbon monoxide. The catalyst works best when the Air Fuel (A/F) ratio is at or near the optimum of 14.7 to 1.

The PCM is programmed to maintain the optimum air/fuel ratio of 14.7 to 1. This is done by making short term corrections in the fuel injector pulse width based on the O₂S sensor output. The programmed memory acts as a self calibration tool that the engine controller uses to compensate for variations in engine specifications, sensor tolerances and engine fatigue over the life span of the engine. By monitoring the actual fuel-air ratio with the O₂S sensor (short term) and multiplying that with the program long-term (adaptive) memory and comparing that to the limit, it can be determined whether it will pass an emissions test. If a malfunction occurs such that the PCM cannot maintain the optimum A/F ratio, then the MIL will be illuminated.

CATALYST MONITOR

To comply with clean air regulations, vehicles are equipped with catalytic converters. These converters reduce the emission of hydrocarbons, oxides of nitrogen and carbon monoxide.

Normal vehicle miles or engine misfire can cause a catalyst to decay. A meltdown of the ceramic core can cause a reduction of the exhaust passage. This can increase vehicle emissions and deteriorate engine performance, driveability and fuel economy.

The catalyst monitor uses dual oxygen sensors (O₂S's) to monitor the efficiency of the converter. The dual O₂S's sensor strategy is based on the fact that as a catalyst deteriorates, its oxygen storage capacity and its efficiency are both reduced. By monitoring the oxygen storage capacity of a catalyst, its efficiency can be indirectly calculated. The upstream O₂S is used to detect the amount of oxygen in the exhaust gas before the gas enters the catalytic converter. The PCM calculates the A/F mixture from the output of the O₂S. A low voltage indicates high oxygen content (lean mixture). A high voltage indicates a low content of oxygen (rich mixture).

When the upstream O₂S detects a lean condition, there is an abundance of oxygen in the exhaust gas. A functioning converter would store this oxygen so it can use it for the oxidation of HC and CO. As the converter absorbs the oxygen, there will be a lack of

DESCRIPTION AND OPERATION (Continued)

oxygen downstream of the converter. The output of the downstream O2S will indicate limited activity in this condition.

As the converter loses the ability to store oxygen, the condition can be detected from the behavior of the downstream O2S. When the efficiency drops, no chemical reaction takes place. This means the concentration of oxygen will be the same downstream as upstream. The output voltage of the downstream O2S copies the voltage of the upstream sensor. The only difference is a time lag (seen by the PCM) between the switching of the O2S's.

To monitor the system, the number of lean-to-rich switches of upstream and downstream O2S's is counted. The ratio of downstream switches to upstream switches is used to determine whether the catalyst is operating properly. An effective catalyst will have fewer downstream switches than it has upstream switches i.e., a ratio closer to zero. For a totally ineffective catalyst, this ratio will be one-to-one, indicating that no oxidation occurs in the device.

The system must be monitored so that when catalyst efficiency deteriorates and exhaust emissions increase to over the legal limit, the MIL (check engine lamp) will be illuminated.

TRIP DEFINITION

The term "Trip" has different meanings depending on what the circumstances are. If the MIL (Malfunction Indicator Lamp) is OFF, a Trip is defined as when the Oxygen Sensor Monitor and the Catalyst Monitor have been completed in the same drive cycle.

When any Emission DTC is set, the MIL on the dash is turned ON. When the MIL is ON, it takes 3 good trips to turn the MIL OFF. In this case, it depends on what type of DTC is set to know what a "Trip" is.

For the Fuel Monitor or Mis-Fire Monitor (continuous monitor), the vehicle must be operated in the "Similar Condition Window" for a specified amount of time to be considered a Good Trip.

If a Non-Continuous OBDII Monitor, such as:

- Oxygen Sensor
- Catalyst Monitor
- Purge Flow Monitor
- Leak Detection Pump Monitor (if equipped)
- EGR Monitor (if equipped)
- Oxygen Sensor Heater Monitor

fails twice in a row and turns ON the MIL, re-running that monitor which previously failed, on the next start-up and passing the monitor is considered to be a Good Trip.

If any other Emission DTC is set (not an OBDII Monitor), a Good Trip is considered to be when the Oxygen Sensor Monitor and Catalyst Monitor have been completed; or 2 Minutes of engine run time if

the Oxygen Sensor Monitor or Catalyst Monitor have been stopped from running.

It can take up to 2 Failures in a row to turn on the MIL. After the MIL is ON, it takes 3 Good Trips to turn the MIL OFF. After the MIL is OFF, the PCM will self-erase the DTC after 40 Warm-up cycles. A Warm-up cycle is counted when the ECT (Engine Coolant Temperature Sensor) has crossed 160°F and has risen by at least 40°F since the engine has been started.

COMPONENT MONITORS

There are several components that will affect vehicle emissions if they malfunction. If one of these components malfunctions the Malfunction Indicator Lamp (Check Engine) will illuminate.

Some of the component monitors are checking for proper operation of the part. Electrically operated components now have input (rationality) and output (functionality) checks. Previously, a component like the Throttle Position sensor (TPS) was checked by the PCM for an open or shorted circuit. If one of these conditions occurred, a DTC was set. Now there is a check to ensure that the component is working. This is done by watching for a TPS indication of a greater or lesser throttle opening than MAP and engine rpm indicate. In the case of the TPS, if engine vacuum is high and engine rpm is 1600 or greater and the TPS indicates a large throttle opening, a DTC will be set. The same applies to low vacuum if the TPS indicates a small throttle opening.

All open/short circuit checks or any component that has an associated limp in will set a fault after 1 trip with the malfunction present. Components without an associated limp in will take two trips to illuminate the MIL.

Refer to the Diagnostic Trouble Codes Description Charts in this section and the appropriate Powertrain Diagnostic Procedure Manual for diagnostic procedures.

NON-MONITORED CIRCUITS

The PCM does not monitor the following circuits, systems and conditions that could have malfunctions causing driveability problems. The PCM might not store diagnostic trouble codes for these conditions. However, problems with these systems may cause the PCM to store diagnostic trouble codes for other systems or components. For example, a fuel pressure problem will not register a fault directly, but could cause a rich/lean condition or misfire. This could cause the PCM to store an oxygen sensor or misfire diagnostic trouble code

FUEL PRESSURE

The fuel pressure regulator controls fuel system pressure. The PCM cannot detect a clogged fuel

DESCRIPTION AND OPERATION (Continued)

pump inlet filter, clogged in-line fuel filter, or a pinched fuel supply or return line. However, these could result in a rich or lean condition causing the PCM to store an oxygen sensor or fuel system diagnostic trouble code.

SECONDARY IGNITION CIRCUIT

The PCM cannot detect an inoperative ignition coil, fouled or worn spark plugs, ignition cross firing, or open spark plug cables.

CYLINDER COMPRESSION

The PCM cannot detect uneven, low, or high engine cylinder compression.

EXHAUST SYSTEM

The PCM cannot detect a plugged, restricted or leaking exhaust system, although it may set a fuel system fault.

FUEL INJECTOR MECHANICAL MALFUNCTIONS

The PCM cannot determine if a fuel injector is clogged, the needle is sticking or if the wrong injector is installed. However, these could result in a rich or lean condition causing the PCM to store a diagnostic trouble code for either misfire, an oxygen sensor, or the fuel system.

EXCESSIVE OIL CONSUMPTION

Although the PCM monitors engine exhaust oxygen content when the system is in closed loop, it cannot determine excessive oil consumption.

THROTTLE BODY AIR FLOW

The PCM cannot detect a clogged or restricted air cleaner inlet or filter element.

LOAD VALUE

ENGINE	IDLE/NEUTRAL	2500 RPM/NEUTRAL
All Engines	2% to 8% of Maximum Load	9% to 17% of Maximum Load

VACUUM ASSIST

The PCM cannot detect leaks or restrictions in the vacuum circuits of vacuum assisted engine control system devices. However, these could cause the PCM to store a MAP sensor diagnostic trouble code and cause a high idle condition.

PCM SYSTEM GROUND

The PCM cannot determine a poor system ground. However, one or more diagnostic trouble codes may be generated as a result of this condition. The module should be mounted to the body at all times, also during diagnostic.

PCM CONNECTOR ENGAGEMENT

The PCM may not be able to determine spread or damaged connector pins. However, it might store diagnostic trouble codes as a result of spread connector pins.

HIGH AND LOW LIMITS

The PCM compares input signal voltages from each input device with established high and low limits for the device. If the input voltage is not within limits and other criteria are met, the PCM stores a diagnostic trouble code in memory. Other diagnostic trouble code criteria might include engine RPM limits or input voltages from other sensors or switches that must be present before verifying a diagnostic trouble code condition.

EVAPORATIVE EMISSION CONTROLS

INDEX

	page		page
DESCRIPTION AND OPERATION		VEHICLE EMISSION CONTROL INFORMATION	
CRANKCASE BREATHER/FILTER—5.2L/5.9L ENGINE	16	(VECI) LABEL	16
CRANKCASE VENTILATION (CCV) SYSTEM—4.0L ENGINE	14	DIAGNOSIS AND TESTING	
DUTY CYCLE EVAP CANISTER PURGE SOLENOID	13	LEAK DETECTION PUMP (LDP)	17
EVAPORATION (EVAP) CANISTER	12	PCV VALVE TEST—5.2L/5.9L ENGINE	16
EVAPORATION CONTROL SYSTEM	12	VACUUM SCHEMATICS	17
LEAK DETECTION PUMP (LDP)	13	REMOVAL AND INSTALLATION	
POSITIVE CRANKCASE VENTILATION (PCV) SYSTEM—5.2L/5.9L ENGINE	14	EVAPORATIVE (EVAP) CANISTER	17
ROLLOVER VALVE	12	EVAPORATIVE CANISTER PURGE SOLENOID	18
		LEAK DETECTION PUMP (LDP)	18
		ROLLOVER VALVE(S)	18
		SPECIFICATIONS	
		TORQUE CHART	19

DESCRIPTION AND OPERATION

EVAPORATION CONTROL SYSTEM

The evaporation control system prevents the emission of fuel tank vapors into the atmosphere. When fuel evaporates in the fuel tank, the vapors pass through vent hoses or tubes to a charcoal filled evaporative canister. The canister temporarily holds the vapors. The Powertrain Control Module (PCM) allows intake manifold vacuum to draw vapors into the combustion chambers during certain operating conditions.

All engines use a duty cycle purge system. The PCM controls vapor flow by operating the duty cycle EVAP purge solenoid. Refer to Duty Cycle EVAP Canister Purge Solenoid in this section.

When equipped with certain emissions packages, a Leak Detection Pump (LDP) will be used as part of the evaporative system. This pump is used as part of OBD II requirements. Refer to Leak Detection Pump in this group for additional information.

NOTE: The evaporative system uses specially manufactured hoses. If replacement becomes necessary, only use fuel resistant hose.

ROLLOVER VALVE

The fuel tank is equipped with a rollover valve. The valve is located on the top of the fuel tank (Fig. 1). The valve will prevent fuel flow through the fuel tank vent (EVAP) hoses in the event of an accidental vehicle rollover. The EVAP canister draws fuel vapors from the fuel tank through this valve.

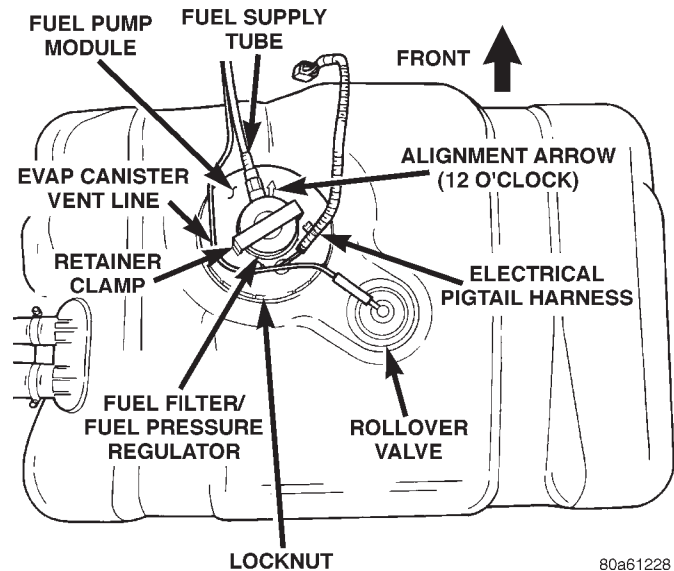


Fig. 1 Rollover Valve Location

80a61228

The valve cannot be serviced separately. If replacement is necessary, the fuel tank must be replaced. Refer to Fuel Tank removal and installation in this group.

EVAPORATION (EVAP) CANISTER

A maintenance free, EVAP canister is used on all vehicles. The EVAP canister is located below the left front headlamp (Fig. 2). The EVAP canister is filled with granules of an activated carbon mixture. Fuel vapors entering the EVAP canister are absorbed by the charcoal granules.

Fuel tank pressure vents into the EVAP canister. Fuel vapors are temporarily held in the canister until

DESCRIPTION AND OPERATION (Continued)

they can be drawn into the intake manifold. The duty cycle EVAP canister purge solenoid allows the EVAP canister to be purged at predetermined times and at certain engine operating conditions.

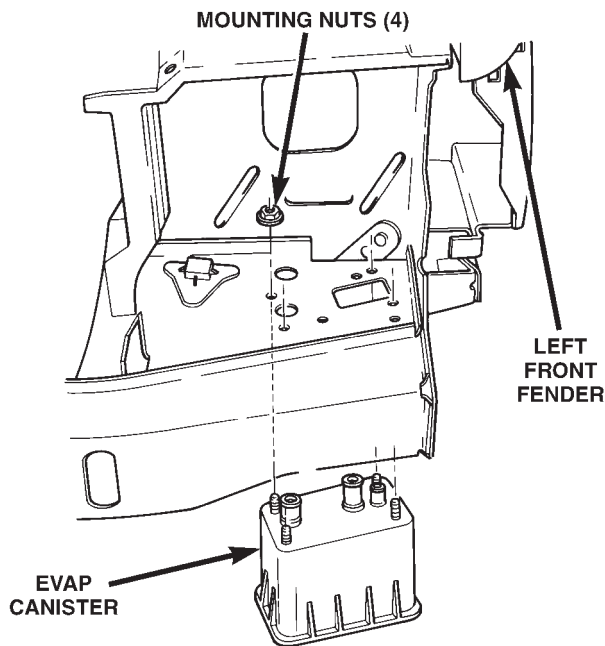


Fig. 2 EVAP Canister Location

DUTY CYCLE EVAP CANISTER PURGE SOLENOID

The 4.0L six-cylinder and 5.2L/5.9L V-8 engines are equipped with a duty cycle EVAP canister purge solenoid. The solenoid regulates the rate of vapor flow from the EVAP canister to the intake manifold. The Powertrain Control Module (PCM) operates the solenoid.

During the cold start warm-up period and the hot start time delay, the PCM does not energize the solenoid. When de-energized, no vapors are purged. The PCM de-energizes the solenoid during open loop operation.

The engine enters closed loop operation after it reaches a specified temperature and the time delay ends. During closed loop operation, the PCM cycles (energizes and de-energizes) the solenoid 5 or 10 times per second, depending upon operating conditions. The PCM varies the vapor flow rate by changing solenoid pulse width. Pulse width is the amount of time that the solenoid is energized. The PCM adjusts solenoid pulse width based on engine operating condition.

The solenoid attaches to a bracket located on the left/inner fender (Fig. 3).

LEAK DETECTION PUMP (LDP)

The Leak Detection Pump (LDP) is used only with certain emission packages.

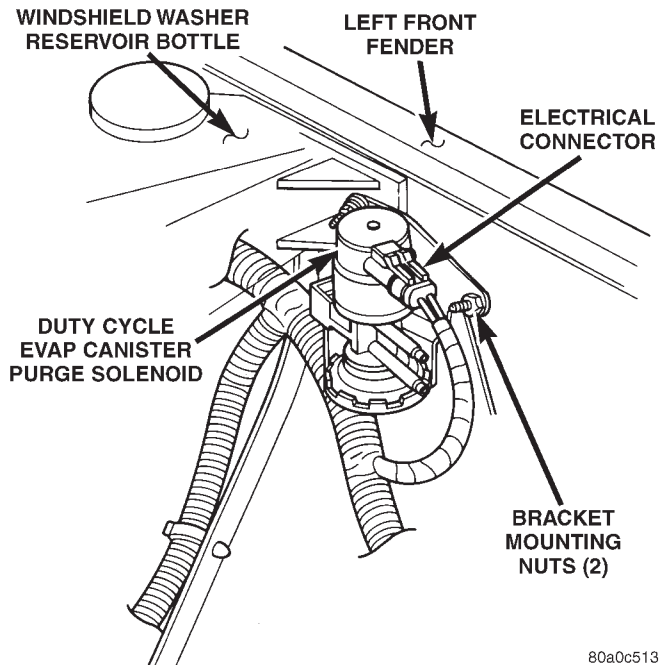


Fig. 3 Duty Cycle EVAP Purge Solenoid Location (Shown Without LDP)

The LDP is a device used to detect a leak in the evaporative system.

The pump contains a 3 port solenoid, a pump that contains a switch, a spring loaded canister vent valve seal, 2 check valves and a spring/diaphragm.

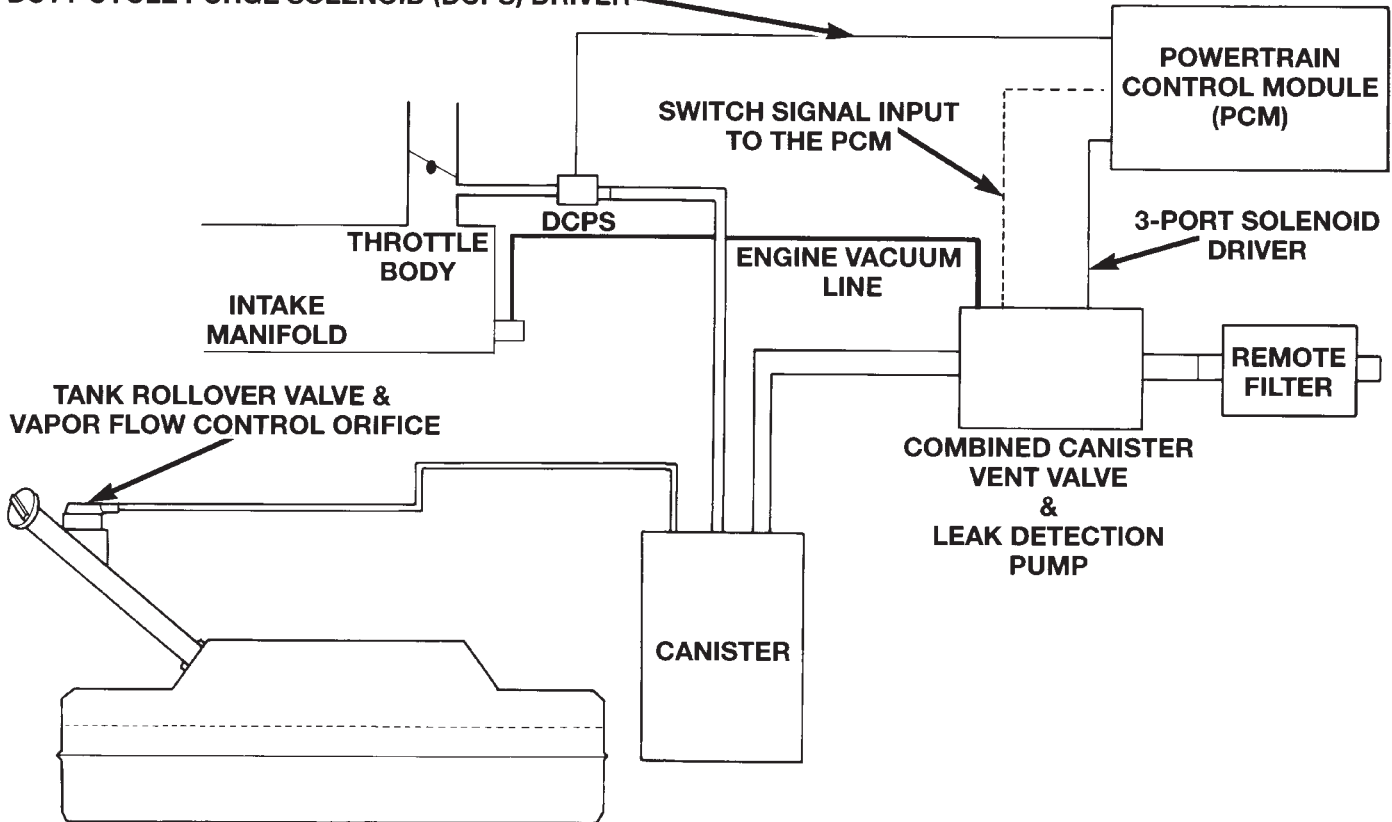
Immediately after a cold start, engine temperature between 40°F and 86°F, the 3 port solenoid is briefly energized. This initializes the pump by drawing air into the pump cavity and also closes the vent seal. During non-test test conditions, the vent seal is held open by the pump diaphragm assembly which pushes it open at the full travel position. The vent seal will remain closed while the pump is cycling. This is due to the operation of the 3 port solenoid which prevents the diaphragm assembly from reaching full travel. After the brief initialization period, the solenoid is de-energized, allowing atmospheric pressure to enter the pump cavity. This permits the spring to drive the diaphragm which forces air out of the pump cavity and into the vent system. When the solenoid is energized and de-energized, the cycle is repeated creating flow in typical diaphragm pump fashion. The pump is controlled in 2 modes:

PUMP MODE: The pump is cycled at a fixed rate to achieve a rapid pressure build in order to shorten the overall test time.

TEST MODE: The solenoid is energized with a fixed duration pulse. Subsequent fixed pulses occur when the diaphragm reaches the switch closure point.

80a0c511

80a0c513

DESCRIPTION AND OPERATION (Continued)**DUTY CYCLE PURGE SOLENOID (DCPS) DRIVER**

80004293

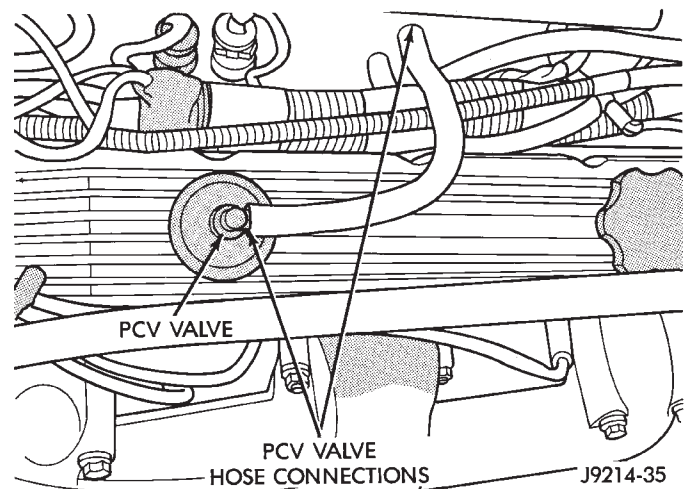
Fig. 4 Evaporative System Monitor Schematic—Typical

The spring in the pump is set so that the system will achieve an equalized pressure of about 7.5 inches of water.

When the pump starts, the cycle rate is quite high. As the system becomes pressurized pump rate drops. If there is no leak the pump will quit. If there is a leak, the test is terminated at the end of the test mode.

If there is no leak, the purge monitor is run. If the cycle rate increases due to the flow through the purge system, the test is passed and the diagnostic is complete.

The canister vent valve will unseal the system after completion of the test sequence as the pump diaphragm assembly moves to the full travel position.

**Fig. 5 PCV Valve/Hose—Typical**

A closed engine crankcase breather/filter, with a hose connecting it to the air cleaner housing, provides the source of air for system.

The PCV system operates by engine intake manifold vacuum (Fig. 6). Filtered air is routed into the crankcase through the air cleaner hose and crankcase breather/filter. The metered air, along with crankcase vapors, are drawn through the PCV valve and into a passage in the intake manifold. The PCV

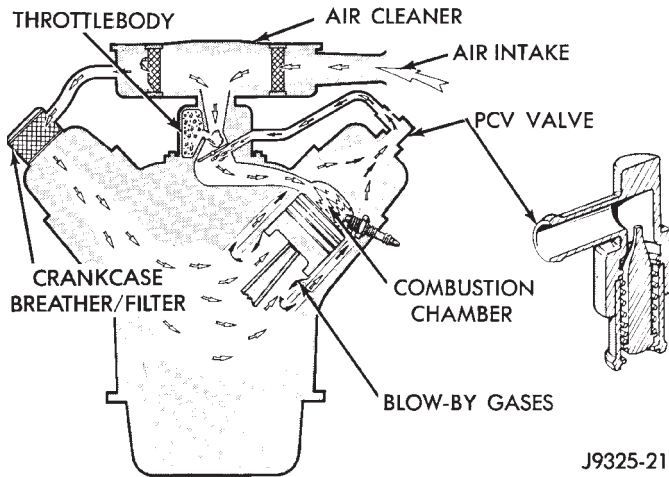
POSITIVE CRANKCASE VENTILATION (PCV) SYSTEM—5.2L/5.9L ENGINE

The 5.2L/5.9L V-8 engine is equipped with a closed crankcase ventilation system and a positive crankcase ventilation (PCV) valve. The 4.0L 6-cylinder engine is not equipped with a PCV valve. Refer to Crankcase Ventilation System—4.0L Engine for information.

This system consists of a crankcase PCV valve mounted on the cylinder head (valve) cover with a hose extending from the valve to the intake manifold.

DESCRIPTION AND OPERATION (Continued)

system manages crankcase pressure and meters blow by gases to the intake system, reducing engine sludge formation.

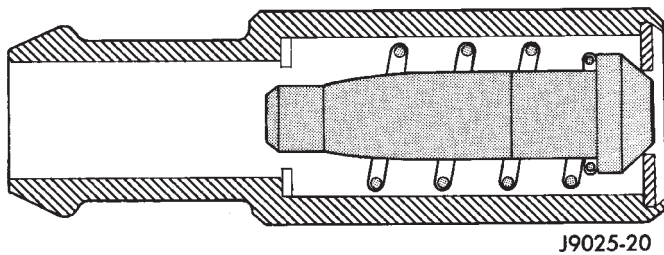


J9325-21

Fig. 6 Typical Closed Crankcase Ventilation System

The PCV valve contains a spring loaded plunger. This plunger meters the amount of crankcase vapors routed into the combustion chamber based on intake manifold vacuum.

When the engine is not operating or during an engine pop-back, the spring forces the plunger back against the seat. This will prevent vapors from flowing through the valve.



J9025-20

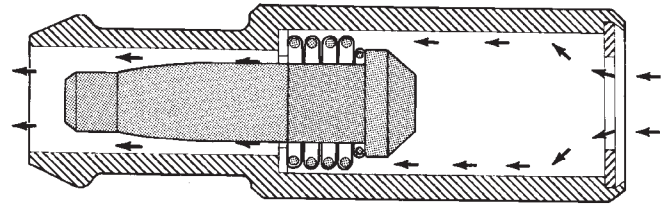
Fig. 7 Engine Off or Engine Pop-Back—No Vapor Flow

During periods of high manifold vacuum, such as idle or cruising speeds, vacuum is sufficient to completely compress spring. It will then pull the plunger to the top of the valve (Fig. 8). In this position there is minimal vapor flow through the valve.

During periods of moderate manifold vacuum, the plunger is only pulled part way back from inlet. This results in maximum vapor flow through the valve (Fig. 9).

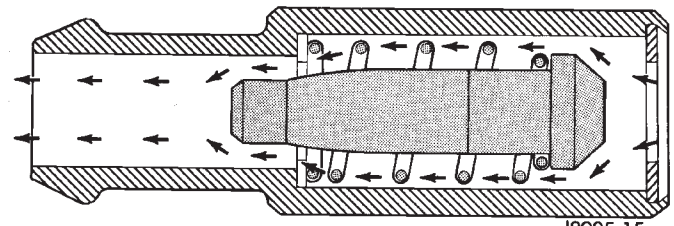
CRANKCASE VENTILATION (CCV) SYSTEM—4.0L ENGINE

4.0L 6-cylinder engines are equipped with a Crankcase Ventilation (CCV) system. The CCV system performs the same function as a conventional



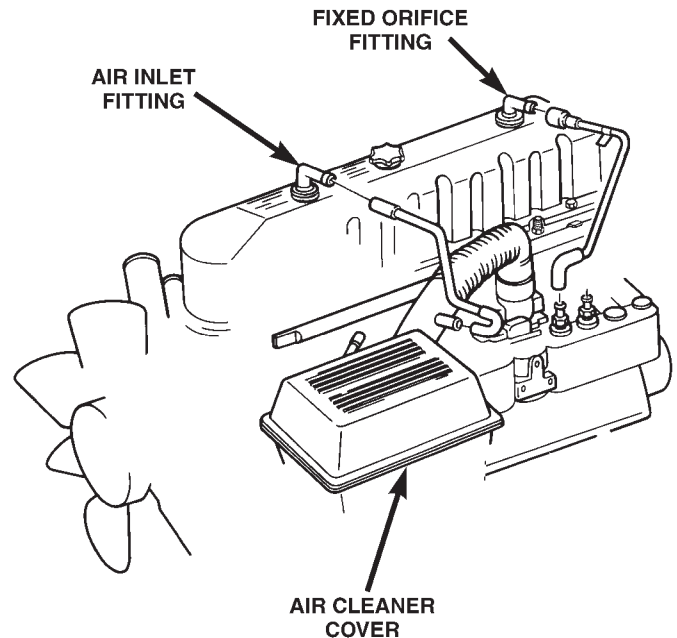
J8925-14

Fig. 8 High Intake Manifold Vacuum—Minimal Vapor Flow



J8925-15

Fig. 9 Moderate Intake Manifold Vacuum—Maximum Vapor Flow



80a0c510

Fig. 10 CCV System—4.0L Engine

PCV system, but does not use a vacuum controlled valve.

A molded vacuum tube connects a fitting on the intake manifold to a fixed orifice fitting of a calibrated size. This fitting meters the amount of crankcase vapors drawn out of the engine. The fixed orifice fitting is located on the top/rear of cylinder head (valve) cover (Fig. 10).

DESCRIPTION AND OPERATION (Continued)

A fresh air supply hose is connected between a fitting on the air cleaner housing and the air inlet fitting at the top/front of cylinder head cover (Fig. 10).

When the engine is operating, fresh air enters the engine and mixes with crankcase vapors. Engine vacuum draws the vapor/air mixture through the fixed orifice and into the intake manifold. The vapors are then consumed during engine combustion.

CRANKCASE BREATHER/FILTER—5.2L/5.9L ENGINE

The crankcase breather/filter (Fig. 11) is located on the cylinder head (valve) cover. The filter may be cleaned by washing in kerosene or similar solvent. Filter must then be thoroughly drained. More frequent service may be necessary for vehicles operated extensively on short run, stop and go or extended engine idle service, or extreme dust conditions.

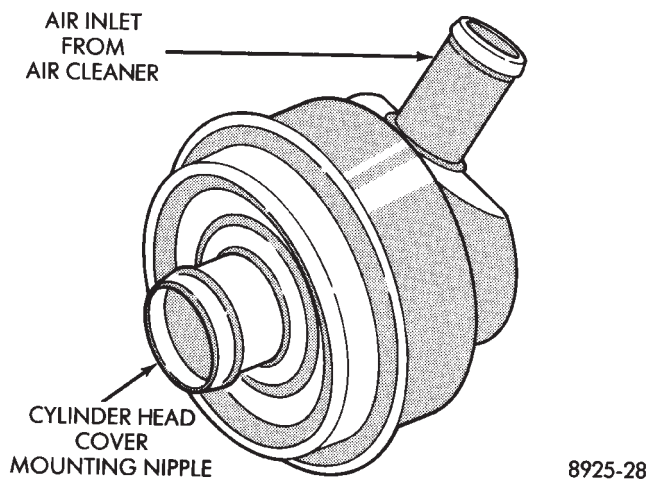


Fig. 11 Crankcase Breather/Filter—5.2L/5.9L Engine

VEHICLE EMISSION CONTROL INFORMATION (VECI) LABEL

All vehicles are equipped with a combined VECI label. This label is located in the engine compartment (Fig. 12) and contains the following:

- Engine family and displacement
- Evaporative family
- Emission control system schematic
- Certification application
- Engine timing specifications (if adjustable)
- Idle speeds (if adjustable)
- Spark plug and gap

The label also contains an engine vacuum schematic. There are unique labels for vehicles built for sale in the state of California and the country of Canada. Canadian labels are written in both the English and French languages. These labels are permanently attached and cannot be removed without defacing information and destroying label.

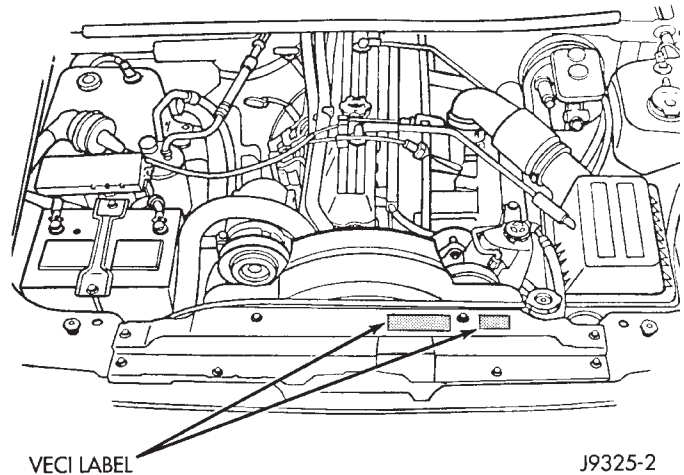


Fig. 12 VECI Label Location—Typical

DIAGNOSIS AND TESTING**PCV VALVE TEST—5.2L/5.9L ENGINE**

(1) With engine idling, remove the PCV valve from cylinder head (valve) cover. If the valve is not plugged, a hissing noise will be heard as air passes through the valve. Also, a strong vacuum should be felt at the valve inlet (Fig. 13).

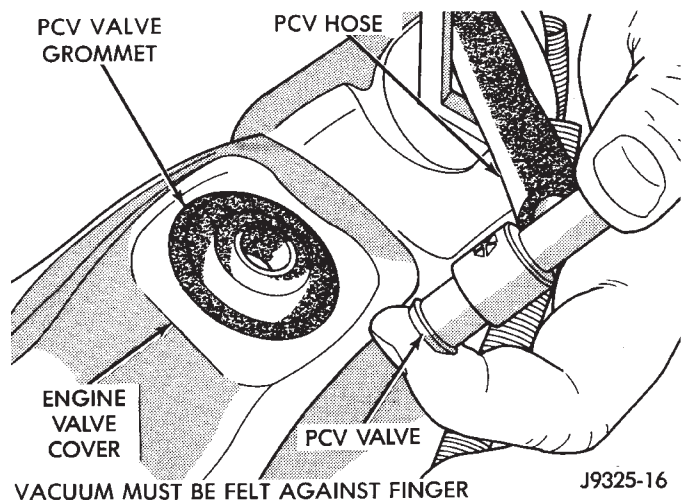


Fig. 13 Check Vacuum at PCV Valve—Typical

(2) Install the PCV valve. Remove the crankcase breather/filter. Hold a piece of stiff paper, such as a parts tag, loosely over the opening of crankcase breather/filter at the cylinder head (valve) cover (Fig. 14).

(3) The paper should be drawn against the opening in the cylinder head (valve) cover with noticeable force. This will be after allowing approximately one minute for crankcase pressure to reduce.

(4) Turn engine off and remove PCV valve from cylinder head (valve) cover. The valve should rattle when shaken (Fig. 15).

DIAGNOSIS AND TESTING (Continued)

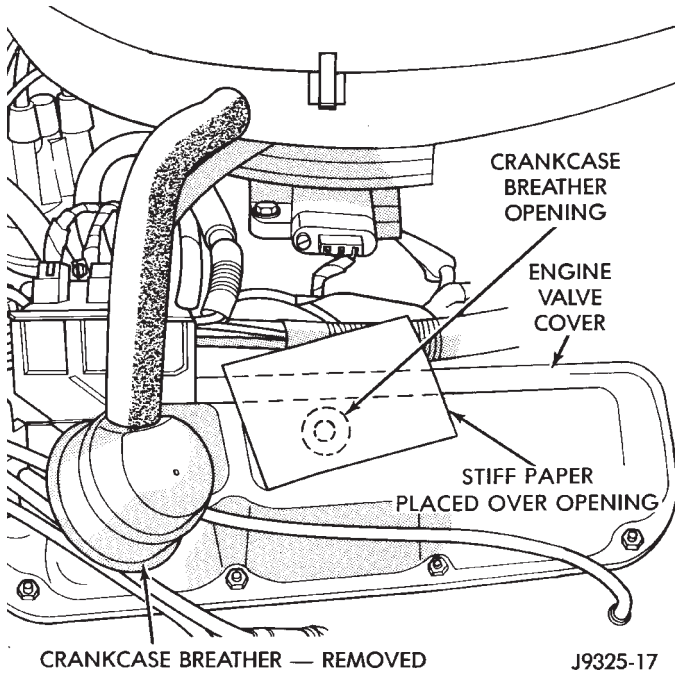


Fig. 14 Check Vacuum at Crankcase Breather Opening—Typical

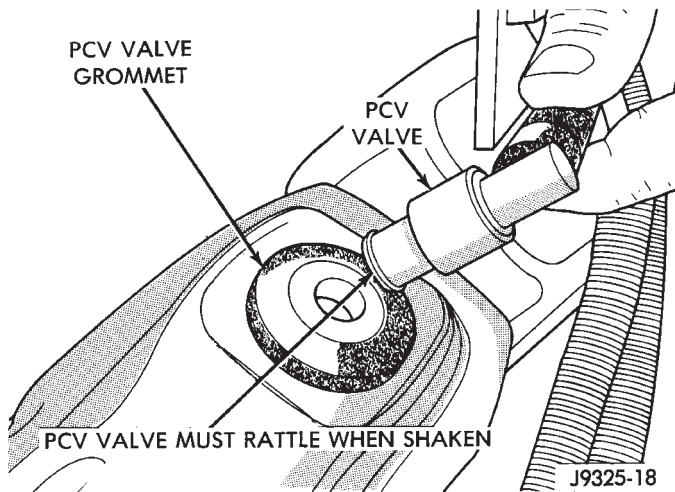


Fig. 15 Shake PCV Valve—Typical

(5) Replace the PCV valve and retest the system if it does not operate as described in the preceding tests. **Do not attempt to clean the old PCV valve.**

(6) If the paper is not held against the opening in cylinder head (valve) cover after new valve is installed, the PCV valve hose may be restricted and must be replaced. The passage in the intake manifold must also be checked and cleaned.

(7) To clean the intake manifold fitting, turn a 1/4 inch drill (by hand) through the fitting to dislodge any solid particles. Blow out the fitting with shop air. If necessary, use a smaller drill to avoid removing any metal from the fitting.

VACUUM SCHEMATICS

A vacuum schematic for emission related items can be found on the Vehicle Emission Control Information (VECI) Label. Refer to VECI Label in this group for label location.

LEAK DETECTION PUMP (LDP)

Refer to the appropriate Powertrain Diagnostic Procedures service manual for LDP testing procedures.

REMOVAL AND INSTALLATION

EVAPORATIVE (EVAP) CANISTER

The EVAP canister is located in the left front corner of vehicle below the left front headlamp (Fig. 16).

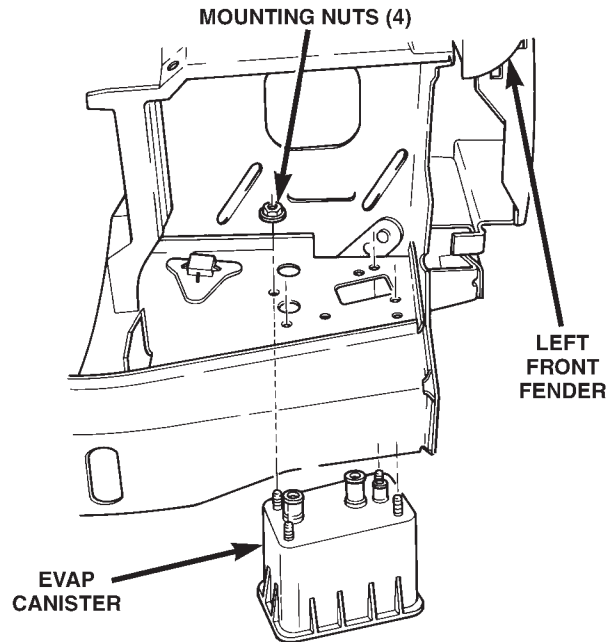


Fig. 16 EVAP Canister Location

REMOVAL

- (1) Remove the grill. Refer to Group 23, Body.
- (2) Remove the front bumper/fascia assembly. Refer to Group 23, Body.
- (3) Disconnect vacuum lines at canister.
- (4) Remove the canister mounting nuts.
- (5) Lower the canister through bottom of vehicle.

INSTALLATION

- (1) Position canister to body.
- (2) Install canister mounting nuts. Tighten nuts to 9 N·m (80 in. lbs.) torque.

REMOVAL AND INSTALLATION (Continued)

(3) Connect vacuum lines. Be sure vacuum lines are firmly connected and not leaking or damaged. If leaking, a Diagnostic Trouble Code (DTC) may be set with certain emission packages.

(4) Install the front bumper/fascia assembly and grill. Refer to Group 23, Body.

EVAPORATIVE CANISTER PURGE SOLENOID**REMOVAL**

The duty cycle evaporative (EVAP) canister purge solenoid is located in the left/front corner of the engine compartment on all engine/emission packages (Fig. 17).

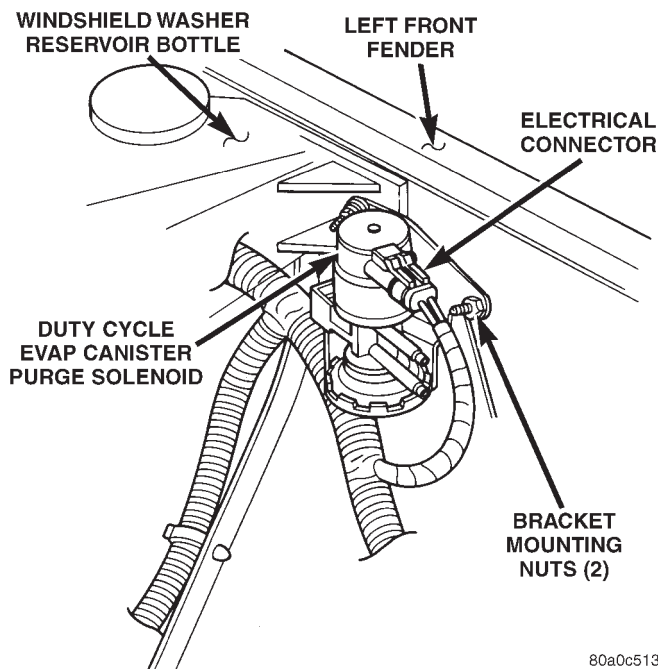


Fig. 17 EVAP Canister Purge Solenoid—Typical

- (1) Disconnect the electrical connector at the solenoid.
- (2) Disconnect the vacuum lines at the solenoid.
- (3) Remove the two bracket mounting nuts and remove solenoid.

INSTALLATION

- (1) Position the solenoid to vehicle.
- (2) Install and tighten the two bracket mounting nuts to 5 N·m (45 in. lbs.) torque.
- (3) Connect the vacuum lines to the solenoid. Be sure the vacuum lines are firmly connected and not leaking or damaged. If leaking, a Diagnostic Trouble Code (DTC) may be set with certain emission packages.
- (4) Connect the electrical connector to the solenoid.

ROLLOVER VALVE(S)

The rollover valve(s) are/is molded into the fuel tank and are not serviced separately. If replacement is necessary, the fuel tank must be replaced. Refer to Fuel Tank Removal/Installation in Group 14, Fuel System for procedures.

LEAK DETECTION PUMP (LDP)

The LDP is located in the left/front corner of the engine compartment below the EVAP canister purge solenoid (Fig. 18). The LDP and LDP filter are replaced (serviced) as one unit.

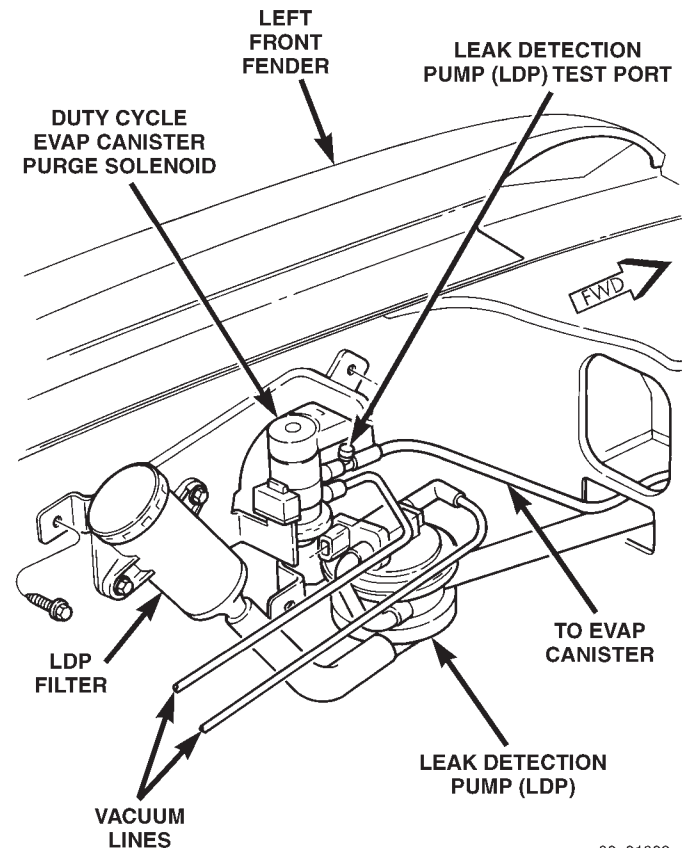


Fig. 18 Leak Detection Pump (LDP) Location

REMOVAL

- (1) Remove air cleaner housing. Refer to Group 14, Fuel System for procedures.
- (2) Carefully remove all vapor/vacuum lines at EVAP canister purge solenoid.
- (3) Disconnect electrical connector at EVAP canister purge solenoid.

REMOVAL AND INSTALLATION (Continued)

- (4) Remove EVAP canister purge solenoid.
- (5) Carefully remove hose at bottom of LDP filter.
- (6) Disconnect electrical connector at LDP.
- (7) Carefully remove vapor/vacuum lines at LDP.
- (8) Remove 2 LDP filter mounting bolts and remove filter.
- (9) Remove LDP mounting bolts/nuts.
- (10) Remove LDP from vehicle.

INSTALLATION

- (1) Install LDP filter to mounting bracket. Tighten bolts to 7 N·m (65 in. lbs.) torque.
- (2) Install LDP to mounting bracket. Tighten bolts/nuts to 7 N·m (65 in. lbs.) torque.
- (3) Carefully install vapor/vacuum lines to LDP and LDP filter. **The vapor/vacuum lines and hoses must be firmly connected. Check the vapor/vacuum lines at the LDP, LDP filter and EVAP canister purge solenoid for damage or leaks. If a leak is present, a Diagnostic Trouble Code (DTC) may be set.**

- (4) Connect electrical connector to LDP.
- (5) Install EVAP canister purge solenoid.
- (6) Install air cleaner housing. Refer to Group 14, Fuel System for procedures.

SPECIFICATIONS

TORQUE CHART

Description	Torque
EVAP Canister Mounting Nuts9 N·m (80 in. lbs.)
EVAP Canister Purge Solenoid Mounting Nuts5 N·m (45 in. lbs.)
LDP Pump Bracket Nuts/Bolts7 N·m (65 in. lbs.)
LDP Filter Mounting Bolts7 N·m (65 in. lbs.)

EMISSION CONTROL SYSTEM

CONTENTS

	page
EXHAUST EMISSION CONTROLS—2.5L DIESEL ENGINE	5
ON-BOARD DIAGNOSTICS—2.5L DIESEL ENGINE	1

ON-BOARD DIAGNOSTICS—2.5L DIESEL ENGINE

INDEX

	page
GENERAL INFORMATION	
SYSTEM DESCRIPTION—2.5L DIESEL ENGINE . . .	1
DESCRIPTION AND OPERATION	
DIAGNOSTIC TROUBLE CODES	2

GENERAL INFORMATION

SYSTEM DESCRIPTION—2.5L DIESEL ENGINE

The 2.5L diesel MSA controller and Powertrain Control Module (PCM) monitor and control many different circuits in the fuel injection pump and engine systems. If the MSA senses a problem with a monitored circuit that indicates an actual problem, a Diagnostic Trouble Code (DTC) will be stored in the PCM's memory, and eventually may illuminate the Diesel Glow Plug lamp constantly while the key is on. If the problem is repaired, or is intermittent, the PCM will erase the DTC after 40 warm-up cycles. A warm-up cycle consists of starting the vehicle when the engine is cold, then the engine warms up to a certain temperature, and finally, the engine temperature falls to a normal operating temperature, then the key is turned off.

Certain criteria must be met for a DTC to be entered into PCM memory. The criteria may be a specific range of engine rpm, engine or fuel temperature and/or input voltage to the PCM. A DTC indicates that the PCM has identified an abnormal signal in a circuit or the system. A DTC may indicate the result of a failure, but never identify the failed component directly.

There are several operating conditions that the MSA does not monitor and set a DTC for. Refer to the following Monitored Circuits and Non-Monitored Circuits in this section.

DESCRIPTION AND OPERATION

DIAGNOSTIC TROUBLE CODES

MONITORED CIRCUITS

The MSA can detect certain problems in the electrical system.

Open or Shorted Circuit – The MSA can determine if sensor output (which is the input to MSA is within proper range. It also determines if the circuit is open or shorted.

Output Device Current Flow – The MSA senses whether the output devices are electrically connected.

If there is a problem with the circuit, the MSA senses whether the circuit is open, shorted to ground (–), or shorted to (+) voltage.

NON-MONITORED CIRCUITS

The MSA does not monitor the following circuits, systems or conditions that could have malfunctions that result in driveability problems. A DTC will not be displayed for these conditions.

Fuel Pressure: Fuel pressure is controlled by the fuel injection pump. The PCM cannot detect problems in this component.

Cylinder Compression: The MSA cannot detect uneven, low, or high engine cylinder compression.

Exhaust System: The MSA cannot detect a plugged, restricted or leaking exhaust system.

Fuel Injector Malfunctions: The MSA cannot determine if the fuel injector is clogged, or the wrong injector is installed. The fuel injectors on the diesel engine are **not controlled** by the MSA, although a defective fuel injector sensor **is monitored** by the PCM.

GENERAL INFORMATION (Continued)

Vacuum Assist: Leaks or restrictions in the vacuum circuits of vacuum assisted engine control system devices are not monitored by the MSA.

MSA System Ground: The MSA cannot determine a poor system ground. However, a DTC may be generated as a result of this condition.

MSA/PCM Connector Engagement: The MSA cannot determine spread or damaged connector pins. However, a DTC may be generated as a result of this condition.

HIGH AND LOW LIMITS

The MSA compares input signal voltages from each input device. It will establish high and low limits that are programmed into it for that device. If the input voltage is not within specifications and other DTC criteria are met, a DTC will be stored in memory. Other DTC criteria might include engine rpm limits or input voltages from other sensors or switches. The other inputs might have to be sensed by the MSA when it senses a high or low input voltage from the control system device in question.

DESCRIPTION AND OPERATION

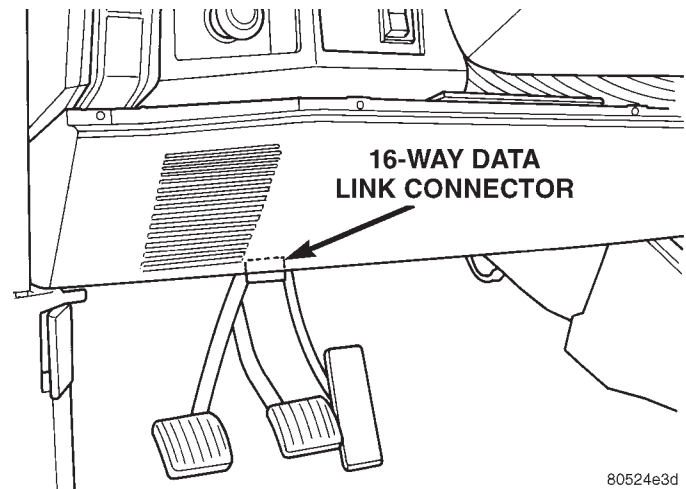
DIAGNOSTIC TROUBLE CODES

On the following pages, a list of DTC's is provided for the 2.5L diesel engine. A DTC indicates that the PCM has recognized an abnormal signal in a circuit or the system. A DTC may indicate the result of a

failure, but most likely will not identify the failed component directly.

ACCESSING DIAGNOSTIC TROUBLE CODES

A stored DTC can be displayed through the use of the DRB III scan tool. The DRB III connects to the data link connector. The data link connector is located under the instrument panel near bottom of the steering column (Fig. 1).



80524e3d

Fig. 1 Data Link Connector Location—Typical

ERASING TROUBLE CODES

After the problem has been repaired, use the DRB III scan tool to erase a DTC.

DESCRIPTION AND OPERATION (Continued)

MSA CONTROLLER DRBIII CODES

Generic Scan Tool Code	DRB III Scan Tool Display
P0100	Mass of Volumes of Air Flow Plausibility Mass of Volumes of Air Flow Signal High Exceeded Mass of Volumes of Air Flow Signal Low Exceeded
P0115	Temperature of Engine Coolant SRC High Exceeded Temperature of Engine Coolant SRC Low Exceeded
P0180	Fuel Temperature Sensor SRC High Exceeded Fuel Temperature Sensor SRC Low Exceeded
P0400	EGR Open Circuit EGR Short Circuit
P0500	Vehicle Speed Sensor PEC Frequency Too High Vehicle Speed Sensor Signal High Exceeded Vehicle Speed Sensor Plausibility
P0725	Engine Speed Sensor Dynamic Plausibility Engine Speed Sensor Over Speed Recognition Engine Speed Sensor Static Plausibility
P1105	Atmospheric Pressure Sensor SRC High Exceeded Atmospheric Pressure Sensor SRC Low Exceeded
P1201	Needle Movement Sensor High Exceeded Needle Movement Sensor Low Exceeded
P1220	Fuel Quantity Actuator Neg. Gov. Deviation Cold Fuel Quantity Actuator Neg. Gov. Deviation Warm Fuel Quantity Actuator Pos. Gov. Deviation Cold Fuel Quantity Actuator Pos. Gov. Deviation Warm
P1225	Control Sleeve Sensor Signal High Exceeded Control Sleeve Sensor Start End Pos. Not Attained Control Sleeve Sensor Stop End Pos. Not Attained
P1230	Timing Control Negative Governing Governor Deviation Timing Control Positive Governing Governor Deviation
P1515	Accelerator Pedal Position Sensor Signal High Exceeded Accelerator Pedal Sensor Signal Low Exceeded Accelerator Pedal Sensor Signal PWG Plaus With Low Idle Switch Accelerator Pedal Sensor Signal PWG Plaus With Potentiometer
P1600	Battery Voltage SRC High Exceeded
P1605	Terminal #15 Plausibility After Startup
P1610	Regulator Lower Regulator Limit

DESCRIPTION AND OPERATION (Continued)

Generic Scan Tool Code	DRB III Scan Tool Display
	Regulator Upper Regulator Limit
P1615	Microcontroller Gate-Array Monitoring Microcontroller Gate-Array Watchdog Microcontroller Prepare Fuel Quantity Stop Microcontroller Recovery Was Occurred Microcontroller Redundant Overrun Monitoring
P1630	Solenoid Valve Controller Open Circuit Solenoid Valve Controller Short Circuit
P1635	Glow Relay Controller Open Circuit Glow Relay Controller Short Circuit
P1650	Diagnostic Lamp Open Circuit Diagnostic Lamp Short Circuit
P1660	Redundant Emer. Stop Plausibility In After-Run Redundant Emer Stop Powerstage Defective
P1665	Cruise Status Indicator Lamp Short Circuit
P1680	EEPROM Plausibility Checksum Error for Adj. EEPROM Plausibility Checksum Error in CC212 EEPROM Plausibility Communication With EEPROM EEPROM Plausibility Func. Switch Wrong or Missing EEPROM Plausibility Ver Number Not Corresponding
P1685	Vehicle Theft Alarm Code Line Breakdown
P1703	Brake Signal Plaus With Redundant Contact
P1740	Clutch Signal Plausibility
P1725	Inductive Aux. Speed Sensor Dynamic Plausibility Inductive Aux. Speed Sensor Overspeed Recognition Inductive Aux Speed Sensor Plausibility Inductive Aux. Speed Sensor Static Plausibility

PCM DRBIII CODES

Generic Scan Tool Code	DRBIII Scan Tool Display
P0117	Engine Coolant Volts Lo
P0118	Engine Coolant Volts Hi
P0500	Vehicle Speed Signal
P0601	Internal Self Test
P1296	5 VDC Output
P1391	Loss of Cam or Crank

EXHAUST EMISSION CONTROLS—2.5L DIESEL ENGINE

INDEX

	page		page
DESCRIPTION AND OPERATION		REMOVAL AND INSTALLATION	
EXHAUST GAS RECIRCULATION (EGR) SYSTEM	5	EGR TUBE	6
VACUUM HOSE ROUTING SCHEMATIC	5	EGR VALVE	6
DIAGNOSIS AND TESTING		ELECTRIC VACUUM MODULATOR (EVM)	7
EGR GAS FLOW TEST	6	SPECIFICATIONS	
EGR SOLENOID TEST	6	TORQUE CHART—2.5L DIESEL	7

DESCRIPTION AND OPERATION

VACUUM HOSE ROUTING SCHEMATIC

Vacuum for the EGR system is supplied by the internal engine mounted vacuum pump. Refer to EGR System Operation for vacuum pump information. Vacuum harness routing for emission related components is displayed in (Fig. 1).

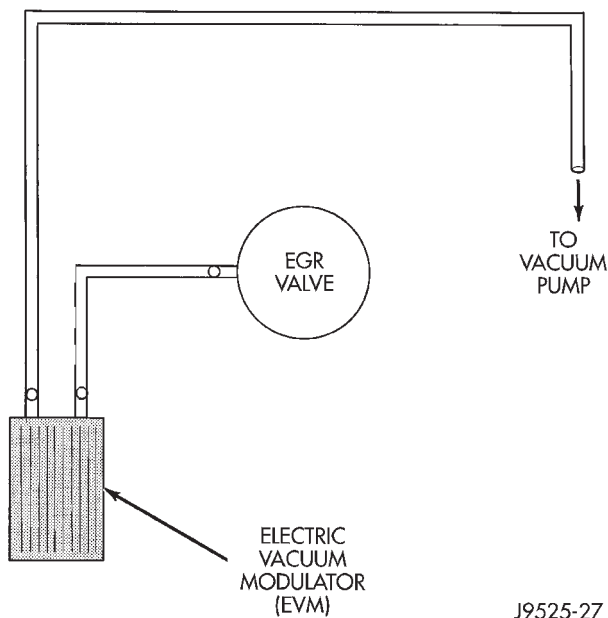


Fig. 1 Typical Hose Routing

EXHAUST GAS RECIRCULATION (EGR) SYSTEM

GENERAL INFORMATION

The EGR system reduces oxides of nitrogen (NO_x) in the engine exhaust. This is accomplished by allowing a predetermined amount of hot exhaust gas to recirculate and dilute the incoming fuel/air mixture.

A malfunctioning EGR system can cause engine stumble, sags or hesitation, rough idle, engine stalling and poor driveability.

EGR SYSTEM OPERATION

The system consists of:

- An EGR valve assembly. The valve is located behind the intake manifold (Fig. 2).

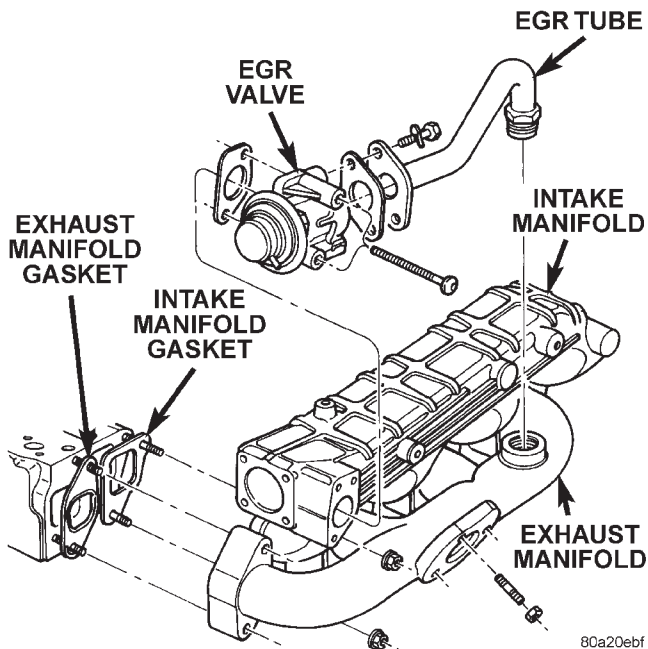


Fig. 2 EGR Valve and Tube Location

- An Electric Vacuum Modulator (EVM). The EVM is sometimes referred to as the EGR control solenoid or EGR duty cycle solenoid. The EVM serves two different functions. One is to control vacuum bleed-off of the EGR valve. The other is to control the “on time” of the EGR valve.

- The MSA operates the EVM. The MSA is located inside the vehicle in the center console.
- An EGR tube (Fig. 2) connecting a passage in the EGR valve to the rear of the exhaust manifold.

DESCRIPTION AND OPERATION (Continued)

- The vacuum pump supplies vacuum for the EVM and the EGR valve. This pump also supplies vacuum for operation of the power brake booster. The pump is located internally in the front of the engine block (Fig. 3) and is driven by the crankshaft gear.

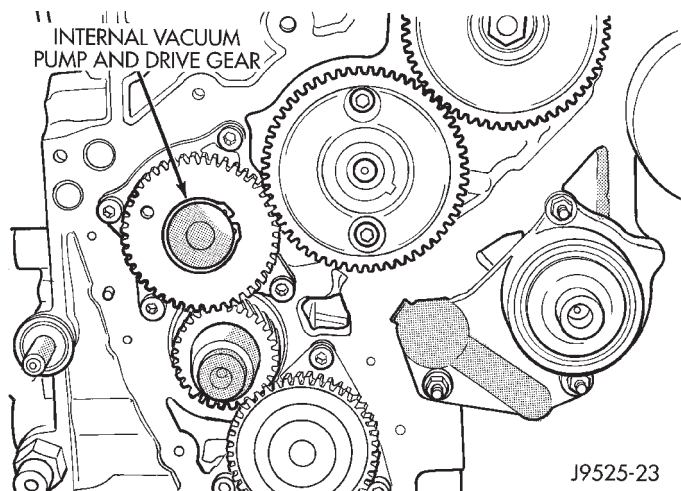


Fig. 3 Internal Vacuum Pump

- Vacuum lines and hoses to connect the various components.

When the MSA supplies a variable ground signal to the EVM, EGR system operation starts to occur. The MSA will monitor and determine when to supply and remove this variable ground signal. This will depend on inputs from the engine coolant temperature, throttle position and engine speed sensors.

When the variable ground signal is supplied to the EVM, vacuum from the vacuum pump will be allowed to pass through the EVM and on to the EGR valve with a connecting hose.

Exhaust gas recirculation will begin in this order when:

- The MSA determines that EGR system operation is necessary.
- The engine is running to operate the vacuum pump.
- A variable ground signal is supplied to the EVM.
- Variable vacuum passes through the EVM to the EGR valve.
- The inlet seat (poppet valve) at the bottom of the EGR valve opens to dilute and recirculate exhaust gas back into the intake manifold.

The EGR system will be shut down by the MSA after 60 seconds of continuous engine idling to improve idle quality.

DIAGNOSIS AND TESTING**EGR GAS FLOW TEST**

Refer to the 1998 XJ/ZG Diesel Powertrain Diagnostic Manual for complete test procedure.

EGR SOLENOID TEST**VACUUM TEST**

With the engine running, disconnect the vacuum supply line at the fitting on the EVM. Minimum vacuum should be no less than 20 inches. If vacuum is lower, check for leaks in vacuum supply line. If leaks cannot be found, check for low vacuum at vacuum pump. Refer to Group 5, Brake System for procedures.

REMOVAL AND INSTALLATION**EGR VALVE****REMOVAL**

- (1) Remove the rubber hose from turbocharger to metal tube.
- (2) Disconnect vacuum line at EGR valve vacuum supply fitting (Fig. 2).
- (3) Loosen the tube fitting at exhaust manifold end of EGR tube (Fig. 2).
- (4) Remove the two bolts retaining the EGR tube to the side of EGR valve (Fig. 2).
- (5) Remove the two EGR valve mounting bolts (Fig. 2) and remove EGR valve.
- (6) Discard both of the old EGR mounting gaskets.

INSTALLATION

- (1) Clean the intake manifold of any old gasket material.
- (2) Clean the end of EGR tube of any old gasket material.
- (3) Position the EGR valve and new gasket to the intake manifold.
- (4) Install two EGR valve mounting bolts. Do not tighten bolts at this time.
- (5) Position new gasket between EGR valve and EGR tube.
- (6) Install two EGR tube bolts. Tighten all four mounting bolts to 23 N·m (204 in. lbs.).
- (7) Tighten EGR tube fitting at exhaust manifold.
- (8) Connect vacuum line to EGR valve.
- (9) Install the rubber hose from turbocharger to metal tube.

EGR TUBE

The EGR tube connects the EGR valve to the rear of the exhaust manifold (Fig. 2).

REMOVAL

- (1) Remove rubber hose from turbocharger to metal tube.
- (2) Remove two EGR tube mounting bolts at EGR valve end of tube (Fig. 2).

REMOVAL AND INSTALLATION (Continued)

- (3) Loosen fitting at exhaust manifold end of tube (Fig. 2).
- (4) Remove EGR tube and discard old gasket.
- (5) Clean gasket mating surfaces and EGR tube flange gasket surfaces.
- (6) Check for signs of leakage or cracked surfaces at both ends of tube, exhaust manifold and EGR valve.

INSTALLATION

- (1) Install a new gasket to EGR valve end of EGR tube.
- (2) Position EGR tube to engine.
- (3) Loosely tighten fitting at exhaust manifold end of tube.
- (4) Install 2 mounting bolts at EGR valve end of tube. Tighten bolts to 23 N·m (204 in. lbs.) torque.
- (5) Tighten fitting at exhaust manifold end of tube.
- (6) Install hose from turbocharger to metal tube.

ELECTRIC VACUUM MODULATOR (EVM)

The EVM (EGR Duty Cycle Purge Solenoid) is mounted to the side of the PDC.

REMOVAL

- (1) Disconnect both cables from battery, negative cable first.
- (2) Remove 2 screws holding PDC to bracket, swing out of way.
- (3) Remove nut and clamp holding battery to battery tray (Fig. 4).
- (4) Remove battery from vehicle.
- (5) Disconnect two vacuum hoses at EVM.
- (6) Remove mounting screws of EVM.
- (7) Remove the EVM to gain access to the EVM electrical connector.
- (8) Remove electrical connector at EVM.

INSTALLATION

- (1) Install electrical connector to EVM.
- (2) Install EVM and tighten mounting screws.

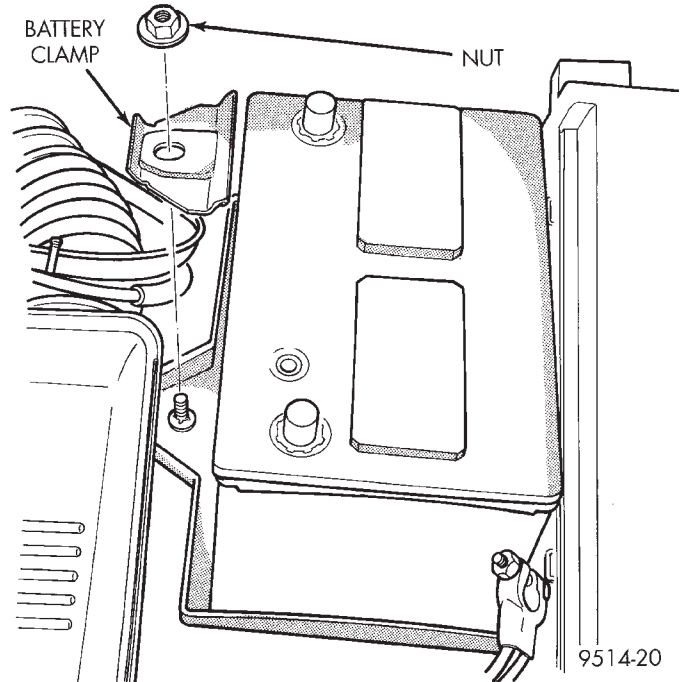


Fig. 4 Battery Clamp

- (3) Connect vacuum hoses.
- (4) Install PDC to bracket and tighten mounting screws.
- (5) Install battery.
- (6) Connect battery cables positive first.

SPECIFICATIONS

TORQUE CHART—2.5L DIESEL

Description	Torque
EGR Valve Mounting Bolts . . .	23 N·m (204 in. lbs.)
EGR Tube Mounting Bolts	23 N·m (204 in. lbs.)
EVM (Electric Vacuum Modulator)	
Mounting Bolt.	2 N·m (20 in. lbs.)

