







SCULPTED AND ATHLETIC. Meet the all-new heir to Grand Cherokee's nearly 20-year heritage of original, innovative design. Nearly every exterior surface has been reimagined to improve aerodynamics and reduce noise, vibration, and harshness.



Leave it to Jeep® Grand Cherokee to deliver this unique brand of hand-hewn character in a modern package that's altogether uncompromising. This is where new meets old and the most beautiful of adventures begin.

Jeep



AN ARTIST'S EYE FOR DETAIL. Interior designers took exceptional care and attention with Grand Cherokee's all-new cabin. Soft-touch accents, hands-free technology, and utterly luxurious amenities are crafted with an artisan's eye for detail.

The adventure of designing a masterpiece.

The challenge of merging all-new capability with appointments of effortless grace was formidable. The result? An evolutionary masterpiece culled from 70 years of rugged Jeep® brand expertise, a steady hand, and a palate for detailed finery. This is the all-new Jeep Grand Cherokee.



INGENUITY UNLEASHED. The imaginations of Grand Cherokee's designers and engineers were given free reign to create an all-new SUV that exceeds all expectations. After literally hundreds of handmade and computer-aided sketches and designs, the results revealed in the 2011 Jeep Grand Cherokee are simply stunning.

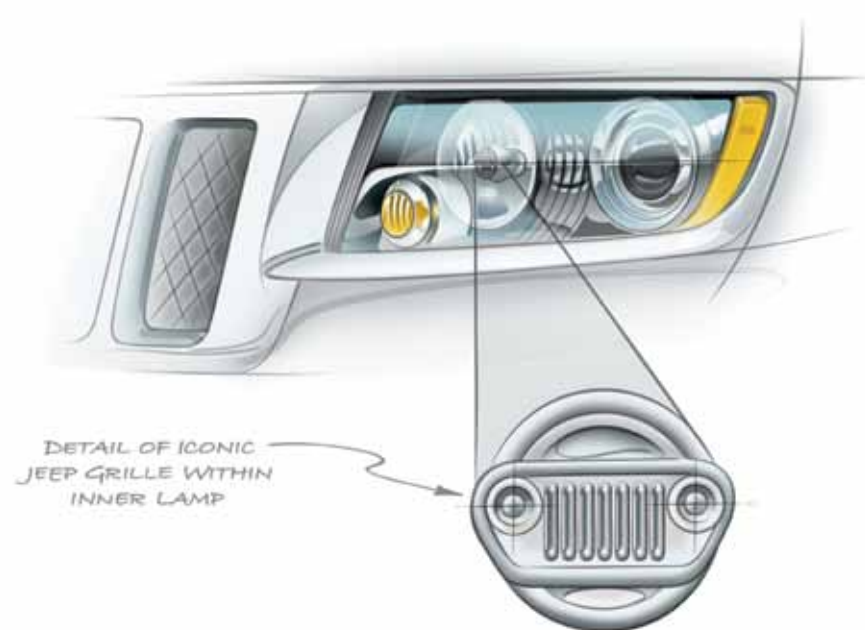

DETAIL OF ICONIC JEEP GRILLE WITHIN INNER LAMP

TIMELESS DESIGN.

Jeep brand vehicles are among the most easily recognized in the world. With the all-new Grand Cherokee, you also see something more: it has taken a breathtaking step forward. A higher, wider stance reflects tremendous strength. The traditional seven-slot grille and trapezoidal wheel arches tell the world you're driving a legend.

INNOVATIVE ENGINEERING.

Redefine world-class capability and luxury. Thus, with this formidable task firmly in hand, Jeep brand engineers have infused Grand Cherokee with technical wonders, like the class-exclusive Quadra-Lift™, Selec-Terrain™, Adaptive Cruise Control® (late availability), and luxurious feel-good amenities, such as the available CommandView® dual pane sunroof.

QUALITY ASSURED.

Jeep brand engineers and testers helped validate Grand Cherokee's solid durability and strength by devoting countless hours to wind, noise, and aerodynamic evaluations. Their tireless work helps ensure Grand Cherokee's weather-tight, quiet ride. It's capability was proven in the most extreme conditions, like those on the Rubicon Trail.



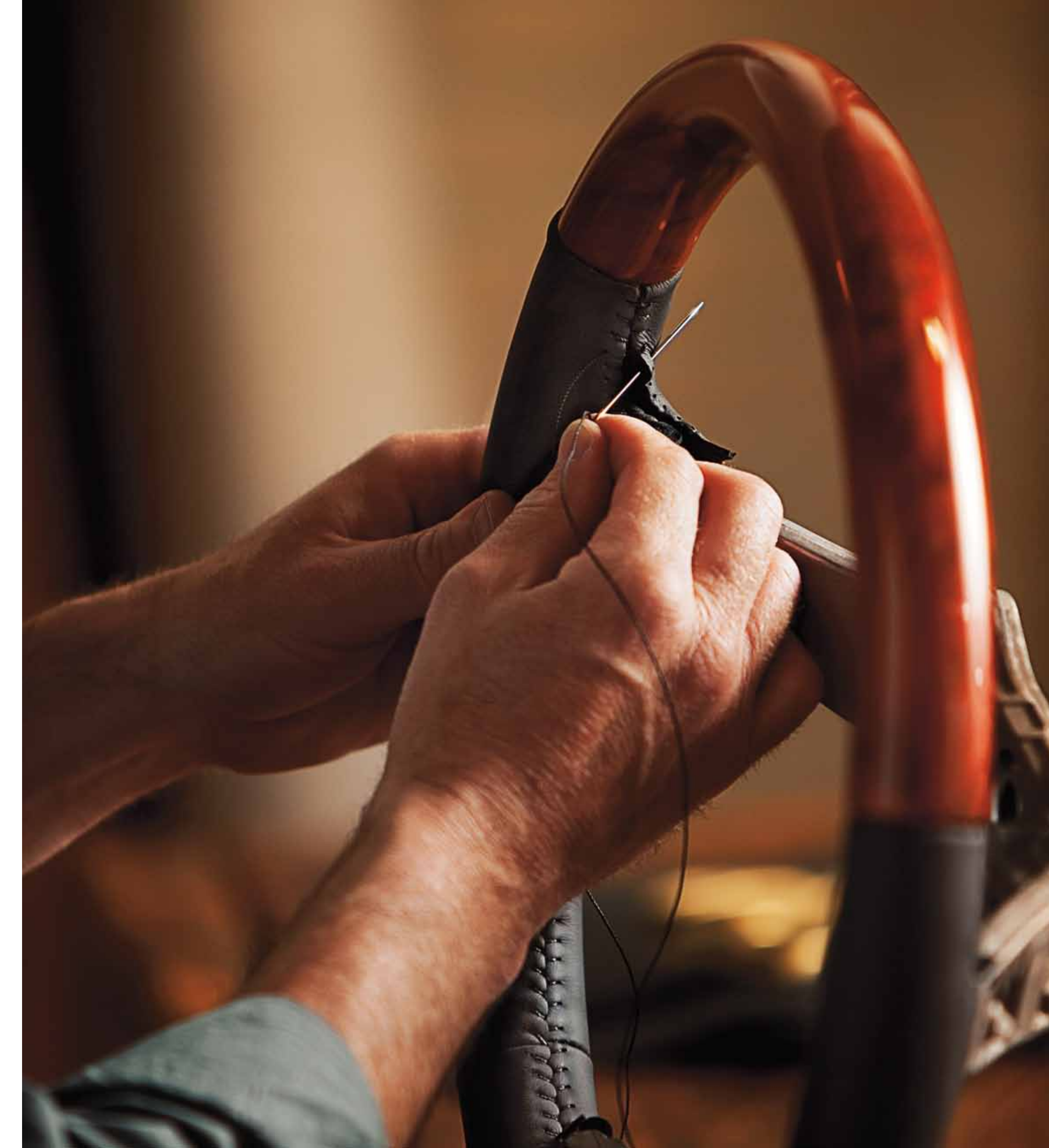

THIS INTERIOR LEAVES NOTHING TO WANT. The meticulously hand-stitched leather-covered tilt/telescoping steering wheel with cruise control, EVIC, and remote audio control are standard. Available: Real wood, heated power tilt/telescoping steering wheel, including Uconnect® with Voice Command, hands-free phone, and Adaptive Cruise Control¹ (ACC).

THE DIFFERENCE IS IN THE DETAILS. Every surface within reach is soft to the touch. Available real wood, chrome details, and stitching accents offer exceptional craftsmanship. With Keyless Enter-N-Go, your key can stay in your pocket or purse — and your journey begins with the simple push of a button.

THESE SEATS ARE ABSOLUTELY ALL-INVITING. All-new premium seats are designed for comfort and versatility and deliver with every stylish stitch. Standard: eight-way power driver's seat, power lumbar control, reclining rear seats, and detailed stitching. Available: premium leather-trimmed interior, eight-way power passenger seat, heated first- and second-row seats, and ventilated front seats.

BEST-IN-CLASS REAR SEAT LEG ROOM.¹¹
 Now more comfortable than ever, the 2011 Grand Cherokee adds four inches of leg room to the second row of reclining seats. Available heated rear seats further complement passenger comfort.

COMMANDVIEW[®] DUAL PANE PANORAMIC SUNROOF.
 This new, available feature delivers commanding views that might otherwise go unnoticed. Two large panes of glass provide a clear view to the sky, with power open/close control and a power sunshade to help keep things cool when needed.

SMART UTILITY. A larger rear cargo area opens to reveal 36.3 cubic feet of room for gear. Appointments are useful as well as stylish with available attractive floor-protecting runners, a removable rechargeable flashlight, grocery hooks, and dual storage bins inside the spare tire compartment, now conveniently placed under the cargo floor.

PREMIUM RIDE AND HANDLING. You're protected from the world and its worries, thanks to Grand Cherokee's hushed and smooth ride. A stronger UniFrame construction, manufacturing improvements that tighten fit and finish, additional sound dampening elements, and new steering and suspension designs come together to deliver a controlled and quietly luxurious ride.



CLASS EXCLUSIVE¹¹
Quadra-Lift[™] Air Suspension

Adding to Grand Cherokee's all-new roster of robust and finely tuned technologies is the available Quadra-Lift, engineered to take you to incredible new heights. This closed-type air suspension system lifts you up to master the road ahead, allowing you to electronically adjust the suspension, thus augmenting its capabilities. Rather than drawing exterior air, like more power- and time-consuming open-type systems, Grand Cherokee sends stored, pressurized air to the springs as needed. In turn, the system re-pressurizes the reservoir, rather than releasing the air out of the vehicle. This gives you the ability to quickly adjust your vehicle height, no matter the altitude. It also raises the vehicle from back to front, keeping headlights focused downward at the road in front of you, supporting a safe and smoother transition. The available Quadra-Lift adds up to 4.1 inches of lift supported by four-corner air springs that help provide a cushioned, luxurious ride. Better yet: you control this ingenious system with the push of a button or turn of a dial. Welcome to a world that is far above and beyond the everyday.



4.1 INCHES OF LIFT SPAN

- OFF-ROAD 2 (+2.6")** Best-in-Class¹¹ 10.7" ground clearance
- OFF-ROAD 1 (+1.3")** Added height helps clear obstacles
- NORMAL RIDE HEIGHT** A very capable 8.1" of clearance
- AERO MODE (-.5")** Improved aerodynamics
- PARK MODE (-1.5")** Easier entry, exit, and loading



ALL-NEW CAPABILITY CONTROL
Selec-Terrain[™] System

Optimal on- and off-road traction is instantly at hand with the available class-leading Selec-Terrain.¹¹ Five selectable settings electronically coordinate 12 different vehicle management systems, including Hill Start Assist (HSA), Hill Descent Control (HDC), throttle control, transmission shifting, transfer case, traction control, and Electronic Stability Control (ESC).[®] Coupled with the all-new available four-corner Quadra-Lift,[™] you'll have an adjustable suspension span that delivers legendary Jeep, brand Trail Rated[®] performance.

SAND/MUD
 Traction control operates with aggressive response to wheel spin. The suspension raises for optimal performance.

SPORT
 Improves on-road fun-to-drive capability with enhanced torque-split and aerodynamics.

AUTO
 Intuitively adapts to any on- or off-road situation. It perfectly orchestrates 12 vehicle systems so you can simply enjoy the drive.

SNOW
 Adjusts for ultimate performance over snow- and ice-covered roads by maximizing vehicle stability and minimizing oversteer.

ROCK
 Raises vehicle to maximum height, the transfer case, differential, and throttle coordinate to provide low-speed control.





BADGE OF HONOR. Jeep® Trail Rated® vehicles are designed to tackle challenges like true off-road warriors. They perform to rigorous standards in five performance categories: Articulation, Traction, Maneuverability, Ground Clearance, and Water Fording.⁽¹⁾ Visit jeep.com to learn more about the superior capabilities behind the badge.

SELEC-TERRAIN™ VEHICLE-MANAGEMENT SYSTEM. Enhance Grand Cherokee's renowned 4WD capability. Selec-Terrain tailors traction performance to expertly tackle whatever the road sets before you, be it mud, sand, snow, or rambling two-tracks. It automatically adjusts and coordinates 12 vehicle-management systems, all with a simple turn of a dial.

PENTASTAR™ 3.6L V6 ENGINE. This all-new power plant infuses your Grand Cherokee with a Best-in-Class⁽²⁾ 290 hp, while increasing 4x2 highway fuel economy from 21 to 23 EPA est. mpg. A state-of-the-art design incorporates dual overhead camshafts (DOHC) and structural refinements that allow it to operate quietly while it pours on the power.

QUADRA-LIFT™ AIR SUSPENSION SYSTEM. Gain ultimate control of your suspension system along with a serious lift in off-road performance and capability. This revolutionary class-exclusive system allows you to easily raise your vehicle up to 4.1 additional inches, from park mode to a maximum 10.7 inches of ground clearance.

GRAND CHEROKEE OVERLAND. Premium, world-class Jeep® brand capability seamlessly infused with top-of-the-line luxuries and refinements. **STANDARD:** Exclusive Overland™ badge on liftgate, 3.6L Pentastar™ V6 engine, power liftgate, 20-inch satin carbon painted wheels, Quadra-Trac II™ 4WD system,⁽³⁾ CommandView™ dual pane panoramic sunroof, Selec-Terrain™ vehicle-management system,⁽⁴⁾ remote start, SmartBeam™ Bi-Xenon High-Intensity Discharge (HID) headlamps with auto-leveling, Nappa leather-trimmed seats with edge welting (late availability), ventilated front seats, real Olive Ash burl wood steering wheel, leather-wrapped and stitched instrument panel and armrests, Keyless Enter-N-Go, Uconnect® navigation system and SIRIUS Travel Link™⁽⁵⁾ (late availability), Alpine® Premium Audio System, Infrared Dual Zone Climate Control, ParkSense® Rear Park Assist System,⁽⁶⁾ ParkView™ Rear Back-Up Camera.⁽⁷⁾ **AVAILABLE:** 5.7L V8 engine with Multi-Displacement System (MDS) and VVT, Quadra-Drive® II 4WD system, Quadra-Lift™ air suspension system, Adaptive Cruise Control (ACC)⁽⁸⁾ (late availability), Blind Spot Monitoring⁽⁹⁾ and Rear Cross-Path Detection⁽¹⁰⁾ (late availability), Forward Collision Warning (FCW)⁽¹¹⁾ (late availability).

With an uncompromised ride, when two roads diverge in the woods, yours is always the one best traveled.





CommandView[®] Sunroof. With the available all-new panoramic sunroof, your view is always all-encompassing. By adding this dual paned, sliding-glass ceiling, your travels continue in brilliant high definition. Everyday adventures are wide-screen worthy.





Here's to the well-connected.
Here's to those who travel with a soundtrack and never need maps to know where they're headed.



STAY CONNECTED. Outfit your Grand Cherokee with Uconnect® to help stay in touch with the people, music, and devices that matter most. It acts as the hub for your most important media — cell phone, Internet, satellite radio, navigation system, personal devices such as an iPod® or smart phone. The Uconnect user-friendly systems are designed to make your life easier, wherever you roam.



PHONE. Talking on the phone while driving has never been easier — or more responsible. Uconnect Phone is the in-vehicle, voice-activated communication system that allows you to pair up to seven Bluetooth® compatible phones and then talk virtually hands-free. This system is also clever enough to synchronize with your phone's address book¹³ — up to 1,000 entries — every time you get into your vehicle. Audible text messaging offers instant — and safe — text communication.



WEB. Put the power of high-speed Internet in your vehicle with Uconnect Web.¹⁴ Effortlessly connect any Wi-Fi-enabled device to the Internet at 3G broadband speeds making your vehicle a Mobile HotSpot within a 150-ft range. Use multiple devices at the same time. There's no need for cell cards or software with this unique Authentic Accessory by Mopar — connectivity is all done wirelessly.



VOICE COMMAND. It simplifies driving by letting you keep your eyes on the road and your hands on the wheel. Vocally select FM radio stations, SIRIUS® Satellite Radio²⁰ channels, make and receive calls, select navigation destinations, and record voice memos. This smart system technology can also be trained to better recognize your voice and can understand commands in English, French, and Spanish.



MULTIMEDIA. Manage all of your media. You'll have six ways to access audio, including SIRIUS Satellite Radio²⁰ (your first year of service is included), a 30GB hard drive, and iPod Control with Voice Command and Bluetooth® streaming audio. Rear seat video can be accessed five ways: watch FLO TV^{TM15} with 100s of shows, SIRIUS Backseat TV,^{TM21} DVDs, compatible multimedia devices, and gaming consoles.



NAVIGATION. Provides turn-by-turn guidance by voice command and visual display. It can also locate nearby restaurants, shopping, hospitals, or points of local interest. Add SIRIUS Traffic^{TM22} for real-time traffic updates, including accident alerts, road closings, and traffic flow. Your first year of SIRIUS Traffic service is included.



SIRIUS TRAVEL LINK^{TM23} brings a wealth of useful information to your fingertips including: national weather information for current and forecasted weather, fuel prices to check local gas prices, sports scores for in-game and final scores, as well as weekly schedules and local movie theater listings (late availability).

**BEST-IN-CLASS
STANDARD HORSEPOWER⁽¹⁾**

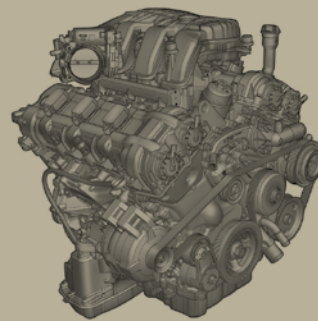

3.6L PENTASTAR™ V6 ENGINE. All-new and engineered equally for fuel efficiency, Best-in-Class horsepower,⁽¹⁾ and refinement. The Pentastar engine makes the most of its dual overhead cams (DOHC) and Variable Valve Timing (VVT) to deliver optimum combustion efficiency over the full speed and load ranges. Translation: it excels its predecessor by providing an increase of 38 percent in horsepower (290 hp) and 11 percent in torque (260 lb-ft) with a very appealing 10 percent improvement in highway fuel economy, delivering up to a 500-mile driving range and an EPA estimate of 16 city and 23 highway miles per gallon on 4x2 models.

Jeep® Grand Cherokee. Redefines the ascent. It's about being polite and powerful within the confines of every incredible instant. Grand Cherokee's Best-in-Class⁽¹⁾ power plants, each infused with Variable Valve Timing (VVT), may speak quietly, but they always command a great deal of respect.



**BEST-IN-CLASS AVAILABLE
HORSEPOWER AND TORQUE⁽¹⁾**

5.7L V8 ENGINE WITH MDS AND VVT. This available workhorse churns out Best-in-Class⁽¹⁾ horsepower and torque. It is strong enough to tow up to 7,400 lb,⁽¹⁶⁾ with a Multi-Displacement System (MDS) that revamps your eight-cylinder, 360-hp brute during cruising speeds, turning it into a four-cylinder model of efficiency. When you want full action, step on the pedal and all eight cylinders roar to life, delivering full 390 lb-ft of torque and power upon request. Variable Valve Timing (VVT) contributes to a pleasing EPA estimate of 14 city/20 highway miles per gallon on 4x2 models.

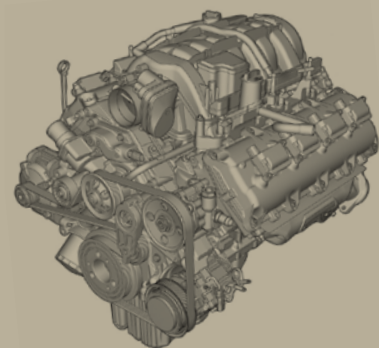

CUSHIONED CRUISING. The impeccable road manners of an all-new independent front and rear suspension system deliver an exceptional driving experience that's quiet and smooth. The available Trailer Tow Package includes load-leveling shock absorbers that automatically raise the vehicle's height when payload is increased. You can continue to cruise with control, even when weighted with heavy cargo.

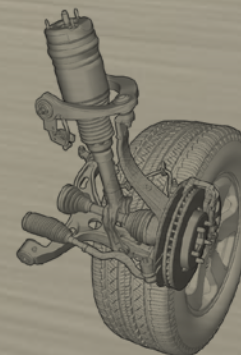

KEYLESS ENTER-N-GO. Live, ride, and drive key-free. This new technology automatically unlocks doors when you pull the handle, letting you keep your focus on more important things, rather than fumbling for a key fob. Once inside, a simple press of the Start/Stop button and brake pedal brings Grand Cherokee's engine to life, and you're instantly prepared for departure.





It reflects a true American heritage, fused with modern cues and curves. The seven-slot grille speaks volumes about its legendary style and capability. Its presence is at once contemporary and timeless. By any measure, there's nothing quite like the all-new 2011 Jeep® Grand Cherokee.

ALWAYS AUTHENTIC, FROM EVERY ANGLE. When your Grand Cherokee is outfitted with Authentic Jeep® Accessories by Mopar, its impressive presence is further amplified. All Mopar products are specifically designed to enhance your vehicle, sculpting it into a creation of impeccable taste and discernment. As the official parts and accessories division of Chrysler Group LLC, you should regard Mopar parts as original equipment, manufactured with the same uncompromising standards as your Jeep Grand Cherokee. Shown on vehicle at left: Chrome Fog Light Bezels, Chrome Tubular Side Steps, Chromed Stainless Steel Mesh Grille Insert, and 20-inch Chrome Wheels. For the full line of Authentic Jeep Accessories by Mopar, visit mopar.com.

SMARTBEAM™ HIGH-INTENSITY HEADLAMPS WITH AUTO-LEVELING. The right beam of light, right when and where you need it. Bi-Xenon High-Intensity Discharge (HID) headlamps automatically and quickly adjust high-beam brightness and intensity so you can keep your attention focused where it matters most. The auto-leveling feature is keen on keeping the headlights aimed safely down at the road.

AUTHENTIC ACCESSORIES

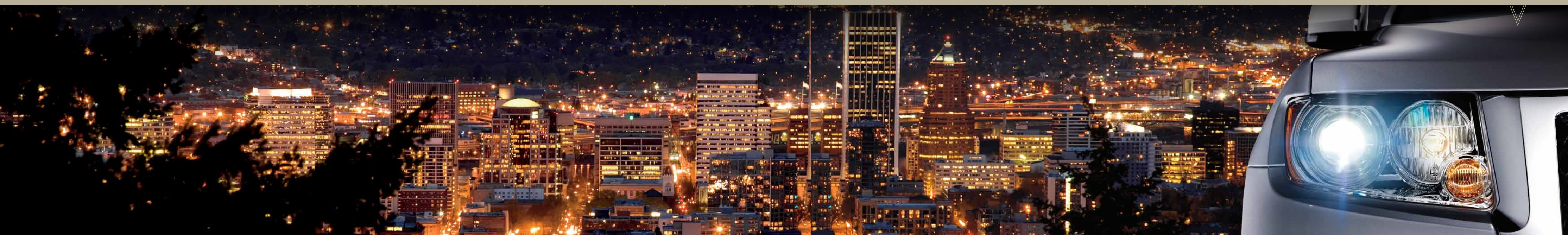



New Saddle color, late availability



EFFORTLESS ACCESS. Designed for beauty as well as ultimate utility, the all-new power liftgate adds graceful accessibility to Grand Cherokee's rear cargo area. Keyless Enter-N-Go is hands-free via the key fob, so you can keep hold of what's in your hands without fumbling to unlock the gate. Rear visibility is improved via a significantly larger flipper glass panel with rear wiper.

MORE CARGO ROOM. With 36.3 cubic feet of cargo volume behind the second-row seats, Grand Cherokee lets you take your adventure gear, along with five passengers, to places known and unknown. When it's time for moving the big things in life, fold down the rear seats to have access to 68.3 cubic feet of free space.



GRAND CHEROKEE LIMITED. Jeep_® brand capability takes on a high level of technologically advanced systems and interior features. **STANDARD:** Exclusive Limited badge on liftgate, 3.6L Pentastar™ V6 engine, Quadra-Trac II[®] 4WD system,¹² CommandView[®] dual pane panoramic sunroof, Selec-Terrain™ vehicle management system,¹³ remote start, Rain-Sensitive Wiper System, SmartBeam™ Bi-Xenon High-Intensity Discharge (HID) headlamps with auto-leveling, Keyless Enter-N-Go, heated first and second row leather-trimmed seats, Uconnect[®] Media Center 430N AM/FM/CD/DVD radio with Garmin[®] navigation (late availability), Uconnect Phone, Alpine[®] Premium Audio System. **AVAILABLE:** 5.7L V8 engine with Multi-Displacement System (MDS) and VVT, Quadra-Drive[®] II 4WD system, Quadra-Lift™ air suspension system, Luxury Group interior trim package, SIRIUS Travel Link™¹⁴ (late availability), Adaptive Cruise Control (ACC)¹⁵ (late availability), Blind Spot monitoring (late availability),¹⁶ Rear Cross-Path Detection[®] (late availability), and Forward Collision Warning (FCW)[®] (late availability)



SURE-FOOTED STYLE AND GRACE. The available new Quadra-Lift™ air suspension system on 4x4 models allows you to lower Grand Cherokee 1.5 inches below normal ride height, for easier entry, exit, and loading. When it comes to on-road manners and interior comfort, a few short inches added to the all-new Grand Cherokee's wheelbase help deliver a ride that is miles above and beyond ordinary. By increasing the wheelbase by 5.3 inches, rear-seat passengers enjoy an extra four inches of Best-in-Class leg room.⁽¹⁾

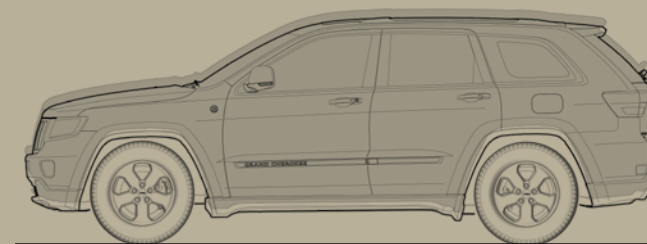



GARMIN GARMIN® NAVIGATION.¹⁰ Debuting on the 2011 Jeep Grand Cherokee is an available upgraded Uconnect® radio featuring optional GPS Navigation from Garmin, the name recognized by drivers everywhere as the dependable, must-have navigation tool. The new radio features Garmin's intuitive user interface, and brings the Garmin consumer experience to a factory in-dash radio (late availability).

NOTABLE DETAILS. Well within reach is Grand Cherokee's all-new finely crafted interior, made of premium soft-touch materials and leathers. The instrument panel and center console feature detailed French stitching for an upscale design.

ADAPTIVE CRUISE CONTROL.¹¹ The evolution of automotive safety and convenience technology continues with Grand Cherokee's new available Adaptive Cruise Control (ACC). When activated during highway cruising, the system constantly monitors the amount of space between your vehicle and those ahead, maintaining a preset distance between you. If traffic slows ahead or another vehicle moves in front of you, ACC slows the vehicle by coasting or engaging the brakes. Conversely, when the vehicle ahead speeds up or moves into another lane, the system accelerates to the preset speed. While no system can operate as quickly as a human, ACC is not affected by weather conditions and can be helpful during inclement weather, such as fog and rain, when visibility is reduced (late availability).

ALPINE® SURROUND SOUND SYSTEM. Step into your own personal sound stage for a realistic concert experience. Alpine's available premium audio system utilizes a high-powered 12-channel, 506-watt amplifier powering nine speakers and a subwoofer optimally placed throughout the cabin. Two 25-mm silk dome tweeters bookend a 3.5-inch center-channel speaker at the front of your cabin. Two 6 x 9-inch premium cone speakers are within the front doors and two 6.5-inch premium speakers are within the rear doors, pushing sound toward the center of the cabin. Two 2.5-inch imaging surround speakers and 8-inch dual voice coil subwoofer send clean sound from behind.

ALPINE.

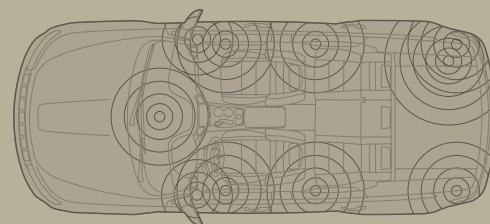

FLO TV™¹² The Living Room is redefined. Now you can receive televised, broadcast programming to keep the entire crew entertained with new, changing and real-time shows available through FLO TV™ Auto Entertainment from Mopar.® Relax listening to familiar news sources on msnbc or FOX News and laugh to the sound of stand-up performances on Comedy Central or morning talk shows on NBC 2Go, without ever averting your eyes from the road. Passenger's attention is caught while the miles fly by watching the latest episodes on Adult Swim Mobile, Disney Channel, MTV, nickelodeon, and more.



Driving terra firma. Grand Cherokee's state-of-the-art safety and security systems keep you firmly grounded. Every mile traveled heightens the experience, with the relaxed confidence that allows you to enjoy your company and the view.







Air bags shown deployed for illustrative purposes only.

Peace of mind takes you and yours far. The all-new 2011 Jeep® Grand Cherokee is reimagined and re-engineered to perform heroically in all driving conditions. You'll feel the strength of its reinforced structure, sheltered within an environment that serves you well. Go boldly forth, empowered with the inspired confidence Jeep Grand Cherokee offers.



Safety and Security Features

ELECTRONIC STABILITY CONTROL (ESC).[®] A vehicle-wide network of safety sensors provide instant aid when they detect that you're veering off your intended path. ESC immediately goes into action when needed.

SMARTBEAM™ HEADLAMPS WITH AUTO-LEVELING. Brighter, better, safer. Bi-Xenon High-Intensity Discharge (HID) headlamps shine up to three times brighter than regular headlamps. A new auto-leveling feature keeps lamps focused down at the road ahead.

A SAFE, SECURE AIR BAG SYSTEM.[®] Always standard: full-length side-curtain, seat mounted side thorax, and advanced multistage front air bags all work in tandem to help provide protection.

RAIN-SENSING WIPERS AND RAIN BRAKE SUPPORT.^(Late Availability) Storm clouds hold little influence over your daily drive. Front wipers activate when raindrops are detected and a new smart brake system helps dry the brake rotors on wet roads.

PARKVIEW[®] and PARKSENSE[®] PARK ASSIST SYSTEMS.[®] Back out with grace. These systems help bring previously hidden rear objects to your attention, either on-screen or with an audible warning, in good time to react.

ADAPTIVE CRUISE CONTROL (ACC).^(Late Availability) The all-new ACC automatically adjusts cruising speed to maintain a preset distance between your Grand Cherokee and the crowd ahead.

BLIND SPOT MONITORING[®] AND REAR CROSS-PATH DETECTION SYSTEM.^(Late Availability) These new sentry systems constantly monitor the personal space between you and other drivers. When a side or rear blind spot is encroached, you're notified via illuminated icons on side-view mirrors or an audible chime.

ACTIVE HEAD RESTRAINTS.^(L) A standard, simple, and effective safety feature that can help stave off neck injuries. Restraints automatically react and adjust to help provide protection during rear-impact collisions.



FORWARD COLLISION WARNING (FCW).^(Late Availability) Even the most attentive drivers will appreciate the help of this new warning system. Approach another vehicle too rapidly and Grand Cherokee lets you know so you can take appropriate action.

ELECTRONIC ROLL MITIGATION (ERM).[®] If things get rough, Grand Cherokee's ERM takes immediate action to help you maintain stability and remain under control.

TRAILER SWAY CONTROL (TSC).[®] Crosswinds and traffic hold no sway over you and your payload. As part of ESC, TSC helps keep you, and the toys you are towing, safely on course and under control.

HILL DESCENT CONTROL (HDC).^(L) and HILL START ASSIST (HSA). These systems are always at your beck and call when you need to get safely around the corner or up and down the mountain.

ANTILOCK BRAKE SYSTEM (ABS). The benefits of ABS on slippery, wet roads are widely known. This advanced system knows when you're driving over rough terrain and adjusts accordingly to help keep you in optimum control.

SENTRY KEY[®] ENGINE IMMOBILIZER. A unique, embedded key code matched only to your vehicle helps keep your Grand Cherokee safely where it belongs.



GRAND CHEROKEE LAREDO. It arrives outfitted with all the finery and capability that makes this Jeep® brand icon a classic. **STANDARD:** Laredo badge on liftgate, 3.6L Pentastar™ V6 engine, Quadra-Trac I® 4WD system,¹²⁰ Electronic Stability Control (ESC),[®] tinted glass, fog lamps, rear liftgate flipper glass, Keyless Enter-N-Go, Media Center 130 AM/FM/CD radio, cloth seats with eight-way power driver's seat, leather-wrapped steering wheel with manual tilt and telescoping steering column, cruise control. **AVAILABLE:** 5.7L V8 engine with Multi-Displacement System (MDS) and VVT, Quadra-Lift™ air suspension system, Selec-Terrain™ vehicle management system, Quadra-Drive® II 4WD system, remote start, CommandView® dual pane panoramic sunroof, Uconnect® with Garmin® navigation system¹⁰⁰ (late availability) and SIRIUS Travel Link™¹²⁰ (late availability), Alpine® Premium Audio System



Make every moment Grand.





2012



Jeep[®]

GRAND
CHEROKEE

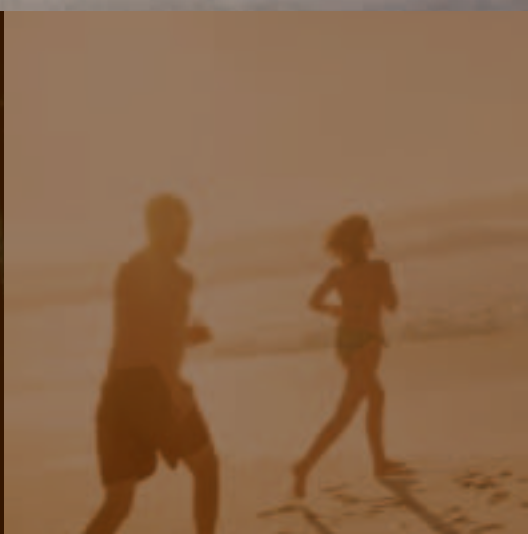



THE MOST BEAUTIFUL OF ADVENTURES HAS BEGUN. A UNIQUE AND DETAILED DESIGN MELTS WITH AN ENTIRELY MODERN CHARACTER. THE RESULT: YOU ARRIVE AT THE PINNACLE OF LUXURY, APPOINTED WITH ADVANCED AMENITIES AND FULLY REALIZED JEEP® BRAND CAPABILITY. THE TIME IS NOW TO MAKE EACH MOMENT GRAND.





CONTENTS

| | |
|----------------------|----|
| + OVERLAND® SUMMIT | 5 |
| + OVERLAND | 11 |
| + LIMITED | 15 |
| + LAREDO | 17 |
| + SRT8® | 19 |
| + CAPABILITY | 23 |
| + ALL-WEATHER | 25 |
| + ENGINES | 29 |
| + SAFETY | 31 |
| + UCONNECT® | 35 |
| + MOPAR® ACCESSORIES | 37 |
| + JEEP® GEAR | 38 |
| + JEEP LIFE | 41 |





1 **PREMIUM, BOLD, DETAILED.** + Overland[®] Summit's iconic seven-slot Jeep[®] grille gets an exclusive chrome treatment, as do the detailed fog lamp bezels. When combined with the prominent chrome tow hooks (late availability) and 20-inch bright polished aluminum wheels, Overland Summit is a sight to behold.

2 **TECHNOLOGY DRIVEN.** + It's hardwired to provide valuable vehicle data on demand, via a variety of resources: the EVIC, the top-line 730N Media Center with navigation, the Uconnect[®] Phone with Voice Command, and Automatic Temperature Control, Blind Spot Monitoring,^{(1)*} and Rear Cross-Path Detection System,⁽²⁾ to name just a few.

3 **THE SEAT OF LUXURY.** + This inviting interior wraps you in sumptuous New Saddle leather and Black Olive Ash Burl real wood trim. A work of uncommonly beautiful art.

4 **COMMANDVIEW[®] SUNROOF.** + This available, dual paned, sliding-glass ceiling reveals new vistas. Power open/close control and a power sunshade help keep things cooler.



{ EXPLORE MORE IN THE ENCLOSED BUYER'S GUIDE OR VISIT JEEP.COM }

* A note about this brochure: All disclaimers and disclosures can be found on the inside back cover.



1



6

OVERLAND® SUMMIT

BEHOLD THE MOST LUXURIOUS JEEP[®] 4x4 EVER BUILT. ITS IMPECCABLE ROAD MANNERS CAN BE COMPARED TO THE SMOOTH RIDE OF A LUXURY SEDAN. THE AVAILABLE TRAIL RATED[®] POWERTRAIN DELIVERS AN EFFICIENT 3.6L V6 ENGINE PAIRED WITH THE LEGENDARY QUADRA-TRAC II[®] 4WD SYSTEM. RIDE HIGH WITH QUADRA-LIFT[®] AIR SUSPENSION AND SELEC-TERRAIN[®] TRACTION MANAGEMENT SYSTEM, ALL STANDARD ON SUMMIT 4x4 MODELS. ENJOY THE VIEW.



2

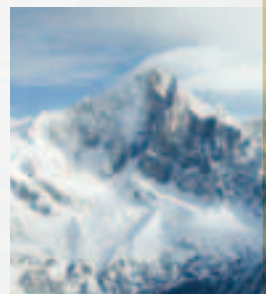

3



4





1



2



3



4

- 1 EXCLUSIVE DNA.** + With a subtle voice that is noticed and noted, Overland Summit declares its presence via its stitched-on-leather logo presented on the front leather-trimmed seats.
- 2 730N MEDIA CENTER.** + Keep your hands safely on the wheel while requesting your Uconnect® 730N Media Center to provide audible navigation, to place a phone call, to send or read a text message, or to play your favorite music selections. This standard system is simple to use as well as simply indispensable. One-year subscription to SiriusXM™ Satellite Radio⁽³⁾ and SiriusXM Traffic™⁽³⁾ are standard.
- 3 WORLD-CLASS CRAFTSMANSHIP.** + Within Overland Summit's interior, Black Olive Ash Burl real wood trim adorns the leather-trimmed steering wheel, front instrument panel, and doors.
- 4 IT'S ALL THERE.** + An exclusive New Saddle leather-trimmed interior, plus the leather-covered tilt/telescoping and heated steering wheel with Adaptive Cruise Control⁽⁴⁾ (ACC), EVIC, and remote audio control – all standard on Overland Summit.





THOSE WHO REACH THIS SUMMIT ARE, BY RIGHTS, DESERVING OF TOP-SHELF TREATMENT. WITH VIRTUALLY THOUSANDS OF DETAILED TREATMENTS, HAND STITCHINGS, CHROME FITTINGS, AND SOFTLY SCULPTED COMFORTS, THE SUMMIT TRANSPORTS ALL WHO ENTER TO A PLACE ABOVE ANY OTHER. WELCOME TO YOUR ROOM WITH AN UNMATCHED VIEW SEEN FROM A DETAILED INTERIOR THAT IS ALTOGETHER LUXURIOUS.





ABOVE AND BEYOND,
THERE'S MORE TO SEE.

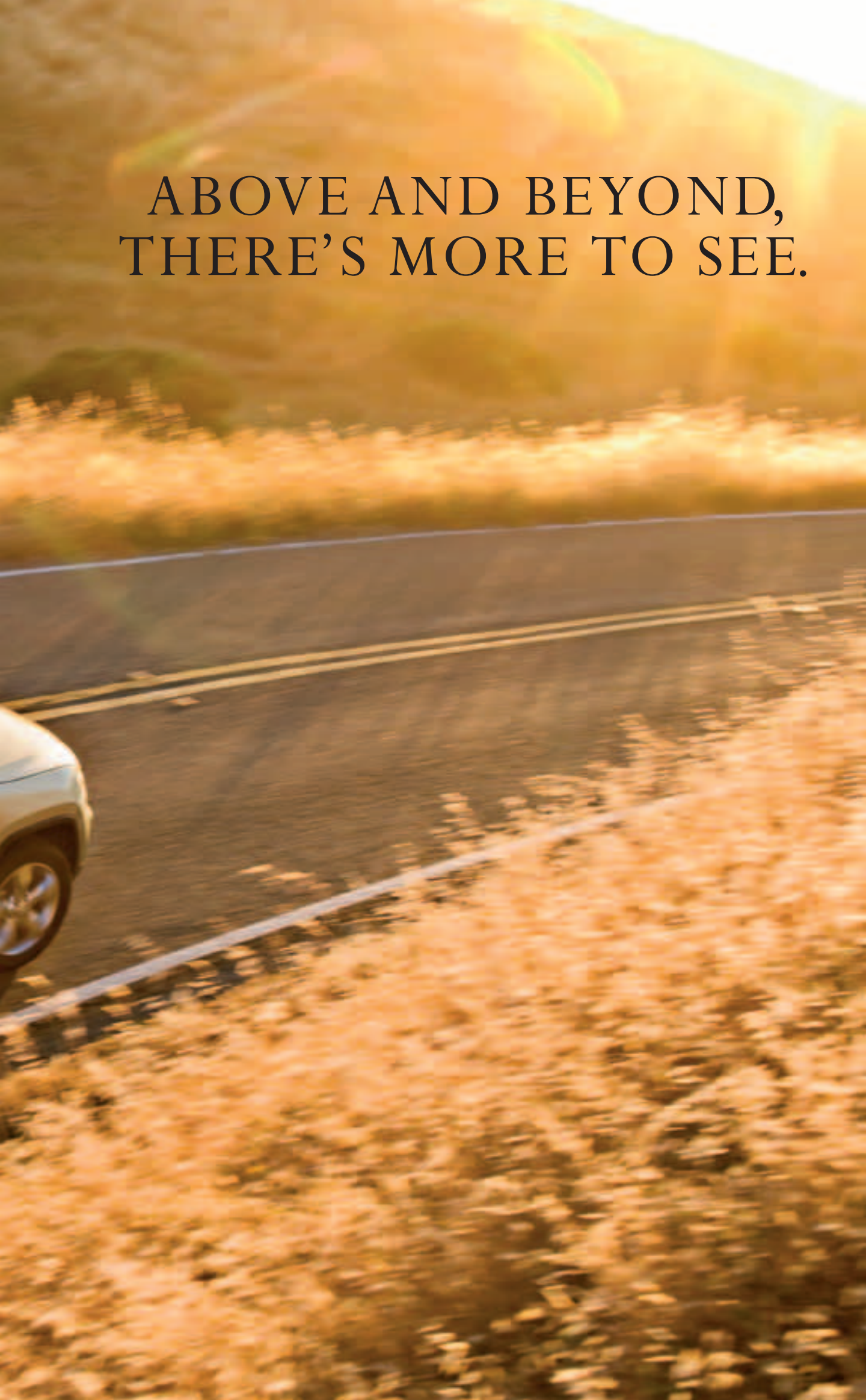



11

OVERLAND®

BESTOWED THE MOST LUXURIOUS VEHICLE IN ITS CLASS,⁽⁵⁾ OVERLAND ARRIVES WITH SUPREME GRACE, EQUIPPED WITH STANDARD LUXURIES, ULTIMATE CAPABILITY AND A BEST-IN-CLASS⁽⁵⁾ 500-MILE DRIVING RANGE BETWEEN FILL-UPS* WITH THE AVAILABLE 3.6L V6 ENGINE. CHOOSE FROM TWO 4x4 SYSTEMS FOR WORRY-FREE TRAVEL THROUGH RAIN, SNOW, MUD, SAND, OR ICE. THE AVAILABLE 5.7L V8 ENGINE DELIVERS BEST-IN-CLASS⁽⁵⁾ HORSEPOWER AND AVAILABLE TORQUE, GIVING YOU 360 HP AND 390 LB-FT OF TORQUE.

* Based on 17 city/23 hwy 4x2 EPA est. fuel economy and a 24.6 gallon fuel tank.

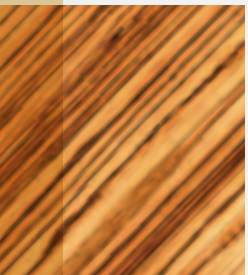



1 **DETAILED DIFFERENCE.** + Every surface within reach is soft to the touch. Olive Ash Burl real wood trim, chrome details, and stitching accents offer exceptional craftsmanship.

2 **A SYSTEMIZED, REVOLUTIONARY RIDE.** + The class-exclusive⁽⁵⁾ Quadra-Lift[®] Air Suspension System gives you ultimate control of your suspension system, along with a serious lift in performance and capability. A standard feature on every Overland 4WD vehicle.

3 **A LUXURIOUS POSITION.** + Overland's standard combo, CommandView[®] dual pane panoramic sunroof and premium Nappa leather-trimmed interior, keeps the view fresh.

4 **LEATHER-WRAPPED GLORY.** + An eight-way power driver's seat with power lumbar control is standard. It sits before a heated, leather-wrapped steering wheel and a leather-wrapped and -stitched instrument panel.

{ EXPLORE MORE IN THE ENCLOSED BUYER'S GUIDE OR VISIT JEEP.COM }

A close-up, high-angle photograph of the driver's side interior of a luxury SUV. The image features a black leather steering wheel with a prominent wood-grain trim on the upper half. The steering wheel has silver-colored control buttons on the left side. Behind the wheel, the instrument cluster is visible, showing a tachometer on the left and a speedometer on the right. The dashboard and center console are finished with dark leather and wood-grain trim. The overall aesthetic is one of classic luxury and craftsmanship.

ARRIVE IN THE
MOST AWARDED
SUV EVER.*

*Based on automotive awards for SUVs from 1995 to 2011.





1 SCULPTED AND ATHLETIC. + Grand Cherokee's muscular profile speaks volumes about its capabilities – as strong and focused as a professional athlete. Its presence is at once contemporary and timeless. All-weather capability comes with your choice of two 4x4 systems, each engineered with exclusive Jeep® brand strength.

2 THE RIGHT LIGHT. + Bi-Xenon High Intensity Discharge (HID) headlamps have SmartBeam™ auto-dimming technology that adjusts high beams to the surrounding sources of light.

3 CARGO HOLD. + Configure your interior to suit the situation. The available power liftgate opens to reveal a large rear cargo area that offers up to 68.3 cubic feet with the rear seat folded down.

4 ADVANCED TECHNOLOGY INFUSION. + Limited's leather-trimmed interior is brimming with standard technological advancements, including a 430N Media Center outfitted with Garmin® Navigation, SiriusXM Travel Link,™(3) and the safe and convenient voice-activated Uconnect® Phone for up to seven Bluetooth® compatible phones. Heated seats warm passengers in the first and second rows.



Properly secure all cargo.

{ EXPLORE MORE IN THE ENCLOSED BUYER'S GUIDE OR VISIT JEEP.COM }



1

LIMITED



16

LIMITED

LIMITED PUTS POWER BEHIND AN EFFICIENT PERFORMANCE, EARNING NODS FOR BEST-IN-CLASS⁽⁵⁾ HORSEPOWER AND DRIVING RANGE. IT'S ALL DUE TO THE 3.6L V6 ENGINE THAT CAN TRAVEL OVER 500 MILES BETWEEN FILL-UPS. THE AVAILABLE 4WD QUADRA-TRAC II[®] 4x4 SYSTEM AND SELEC-TERRAIN[®] VEHICLE MANAGEMENT SYSTEM HELP TO GAIN PASSAGE, WHETHER YOU CHOOSE TO TRAVEL ON ROADS COVERED WITH SNOW, MUD, SAND, OR ROCKS.



2



3



3



4



LAREDO

17

LAREDO

LAREDO TAKES TO THE ROAD WITH THE HUSHED RIDE OF A STEALTH MACHINE, THANKS IN PART TO DOUBLE-DASH CONSTRUCTION AND SURROUNDING ACOUSTIC GLASS. THE STANDARD ELECTRONIC STABILITY CONTROL (ESC)⁽⁶⁾ HELPS YOU REMAIN IN CONTROL AND SAFELY MOVE FORWARD. CARRY THE KEY FOB IN YOUR POCKET, PURSE, OR BRIEFCASE AND THE AVAILABLE KEYLESS ENTER-N-GO AUTOMATICALLY UNLOCKS THE DOORS AND LETS YOU START THE ENGINE WITHOUT USING THE KEY.

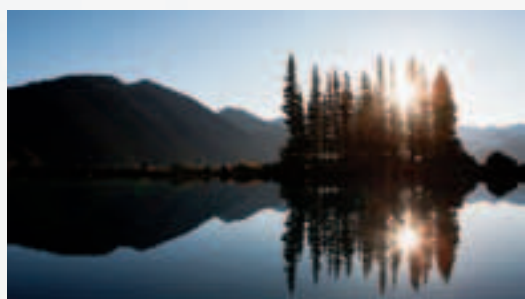



1 DUAL-ZONE AUTOMATIC TEMPERATURE CONTROL (ATC). +

An advanced infrared sensing device automatically checks the surrounding temperature of the driver and front-passenger seats, as well as the air temperature inside the cabin to create a customized, comfortable environment. Available.

2 GO EVERYWHERE. + Laredo's 4x4 powertrain offers a very pleasing EPA estimated 23 highway mpg. A Best-in-Class⁽⁵⁾ driving range of over 500 miles gives you plenty of time and scenery between fill-ups.

3 ALL-INVITING. + The leather-covered steering wheel with cruise control, EVIC, and remote audio control are standard. Opt for Uconnect[®] Voice Command for hands-free communication.

4 AUTHENTIC MOPAR[®] ACCESSORIES. + Made specifically to augment your Grand Cherokee adventures: Roof Top Cargo Basket, Tubular Side Steps, and 18-inch Cast-Aluminum Wheels.

{ EXPLORE MORE IN THE ENCLOSED BUYER'S GUIDE OR VISIT JEEP.COM }



THIS MUSCLE MACHINE TAKES OFF AS THE MOST POWERFUL AND TECHNOLOGICALLY ADVANCED JEEP® VEHICLE EVER BUILT. ITS AGGRESSIVE PROFILE RESEMBLES A HIGH-PERFORMANCE SPORTS CAR WITH FASCIA INTAKES, LED DAYTIME RUNNING LIGHTS, BODY-COLOR GRILLE WITH BLACK MESH AND CHROME INSERTS, AND VENTED HOOD. A REAR SPOILER HELPS SRT8® STICK TO THE ROAD WHEN ITS AWE-INSPIRING 470-HP POWERTRAIN CLIMBS TO A RACE-TRACK SPEED OF 160 MPH. OVER 45 AVAILABLE SAFETY AND SECURITY FEATURES HELP KEEP THINGS IN CHECK.





1 VROOM ROOM. + The cockpit has a leather-wrapped, heated steering wheel with a flat bottom, deeply bolstered leather seats with suede inserts, and carbon-fiber accent trim. An awe-worthy dual-pane sunroof is an available addition. An available SRT® High-Performance Audio System pumps out 825 watts of sound via 19 speakers, including a 10-inch subwoofer.

2 THRILLING. + When its intimidating 6.4L HEMI® V8 engine takes off, SRT8® is fueled by 470 hp and 465 lb-ft of torque, launching you from 0-60 in just 4.8 seconds. The engine's Fuel Saver Technology optimizes fuel efficiency when V8 power is not required, with no sacrifice in performance.

3 NEW MANAGED SUSPENSION. + The new SRT8 adaptive damping suspension is managed by the new Selec-Track system, and gives discerning drivers the choice between five different suspension performance settings (track, sport, auto, snow, tow). Depending on the setting, the system adjusts stability control, damping, transmission shifts, torque proportioning, throttle response, and electronic limited-slip differential for optimal performance according to road conditions and driving style.

SHINY THINGS. + SRT8's new split five-spoke 20-inch forged aluminum wheels ride on Pirelli® PZero run-flat tires.

{ RACE TO DRIVESRT.COM FOR MORE SRT8 THRILLS. }



ON-DEMAND ALTITUDE ADJUSTMENT.

QUADRA-LIFT® AIR SUSPENSION SYSTEM.

Control the lift height and ground clearance of your Grand Cherokee with the simple touch of a button. The available Quadra-Lift helps you gain maximum control over any terrain. Add up to 2.6 inches of ground clearance in Off Road 2 mode, gain efficiency driving in Aero Mode, or lower to Park Mode for an easy vehicle exit or load-up. The four-corner air springs also help provide a cushioned, luxurious ride when you return to pavement. Welcome to a world that is far above and beyond the everyday.



OFF-ROAD 2 +2.6"

OFF-ROAD 1 +1.3"

NORMAL RIDE HEIGHT

AERO MODE -.5"

PARK MODE -1.5"





IT'S A 4x4 WORLD OUT THERE.



CONFIDENCE TO GO ANYWHERE, DO ANYTHING® IS BORN AND BRED IN EVERY JEEP® BRAND TRANSFER CASE. JEEP TRAIL RATED® 4x4s PERFORM TO RIGOROUS STANDARDS IN FIVE CATEGORIES: ARTICULATION, MANEUVERABILITY, TRACTION, GROUND CLEARANCE, AND WATER FORDING.⁽⁷⁾ KEEP MOVING FORWARD, NO MATTER WHAT LIES AHEAD.

CHOOSE YOUR 4x4 SYSTEM

QUADRA-DRIVE® II puts class-leading⁽⁵⁾ capability at hand with its Electronic Limited-Slip Differential (ELSD) that transfers up to 100 percent of torque to the wheel(s) with traction. **QUADRA-TRAC II®** offers all-speed traction control to help keep you on course. If wheel slippage occurs, torque can be routed to the axle with the most traction. Low-range provides rock-crawling prowess.

QUADRA-TRAC I® is fully automatic, no driver interaction is required. A single-speed transfer case offers a continual balance of torque distribution; if wheel slippage occurs, the system seamlessly transfers torque to the axle with traction.

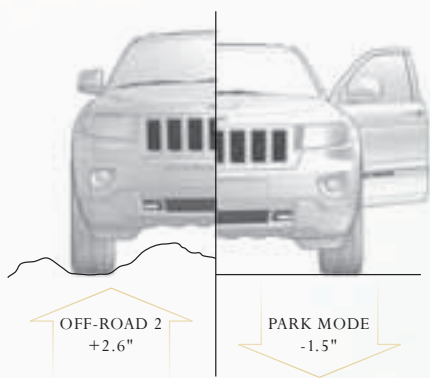

QUADRA-LIFT®

A revolutionary class-exclusive⁽⁵⁾ system that gives you ultimate control of your suspension. It allows you to easily raise your vehicle higher for a maximum Best-in-Class⁽⁵⁾ ground clearance of 10.7 inches above ridges and rocks. Or lower it 1.5 inches for easier entry, exit, and loading. The system also raises the vehicle from back to front to help keep headlights safely focused downward at the road ahead.

SELEC-TERRAIN®

Optimal on- and off-road traction is instantly at hand. Five selectable settings electronically coordinate 12 different vehicle management systems to adjust your traction control to match the road ahead. Whether you're caught in snow-covered city streets or climbing backcountry hills, Selec-Terrain actively manages torque distribution where others may not.





1



2



3



1 INDEPENDENT SUSPENSION. + The front and rear suspension systems and their isolated cradles help Grand Cherokee absorb troubling bumps as if they were never in your way.

2 UNIFRAME CONSTRUCTION. + Renowned ultra-high strength Jeep engineered UniFrame construction yields 146 percent improvement in body stiffness. The numbers add up: 5,400 welds in the body alone, 53 percent increase in spot welds, 42 percent increase in arc welds, and 38 percent increase in structural adhesives.

3 SMOOTH STEERING. + Grand Cherokee's electrohydraulic power steering, teamed with the V6 engine, provides the natural, smooth feel of a sophisticated conventional hydraulic power steering system while simultaneously helping to improve efficiency by using electric power instead of drawing power from the engine.



JEEP. 4x4s LEAD IN ALL WEATHER.

YOU'RE PROTECTED FROM THE
WORLD AND ITS WORRIES,
THANKS TO GRAND CHEROKEE'S
ALL-WEATHER WHEREWITHAL. JEEP
ENGINEERS DEVOTED ENDLESS HOURS
TO ENSURE GRAND CHEROKEE'S 4x4
SYSTEMS CAN SAFELY AND SEAMLESSLY
GET YOU THROUGH THE CHALLENGES
MOTHER NATURE PROVIDES.



WHAT A CLEVER DISGUISE FOR A LUXURY SEDAN.

ROAD MANNERS TO BRAG ABOUT.

When they ask about Grand Cherokee's smooth, refined ride; the hushed, acoustically sound cabin; the easy, controlled cornering, answers come easy. The isolated cradles of the independent front and rear suspension help provide added cushioning likely to recall rides taken in the priciest luxury sedans. The double-dash construction and the premium insulation help stop road noise in its tracks. The exacting fit and finish manufacturing methods are designed to create near-perfect assemblies. It all adds up to an on-road experience that may rival many of the world's most luxurious sedans.

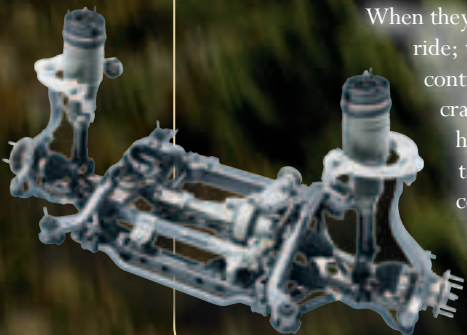





SMART. STRONG.



POWER YOUR GRAND CHEROKEE WITH EITHER THE STANDARD 3.6L PENTASTAR® V6 ENGINE WITH VARIABLE VALVE TIMING (VVT) OR THE AVAILABLE 5.7L V8 ENGINE WITH FUEL SAVER TECHNOLOGY AND VVT, AND EARN RAVES FOR BEST-IN-CLASS⁽⁵⁾ HORSEPOWER AND AVAILABLE TORQUE. BOTH ARE ENGINEERED TO DELIVER THE CAPABILITY YOU EXPECT FROM A JEEP® VEHICLE. THEY ALSO COME PACKAGED WITH EFFICIENCIES THAT HELP PUT MORE MILES AND SCENERY BETWEEN FILL-UPS. INGENIOUS, INDEED.

PENTASTAR 3.6L V6

The Pentastar cranks out enough power to tow up to 5,000 lb.⁽⁸⁾ and the efficiency to achieve a Best-in-Class⁽⁵⁾ nod for its 540 miles-per-tank range. Dual overhead camshafts (DOHC) and structural refinements allow it to achieve an EPA estimated 17 city/23 highway mpg.



290

HORSEPOWER

260

LB-FT OF TORQUE

23

HWY MPG

5.7L HEMI® V8

This available workhorse churns out Best-in-Class⁽⁵⁾ horsepower and available torque, and is strong enough to tow up to 7,400 lb.⁽⁸⁾ **Fuel Saver Technology** revamps this eight-cylinder, 360-hp brute during cruising speeds, turning it into a four-cylinder model of efficiency. It can seamlessly alternate between the higher fuel economy of the four-cylinder mode when less power is needed, yet when you step on the pedal, all eight cylinders quickly roar back to life. Performance is always stellar.

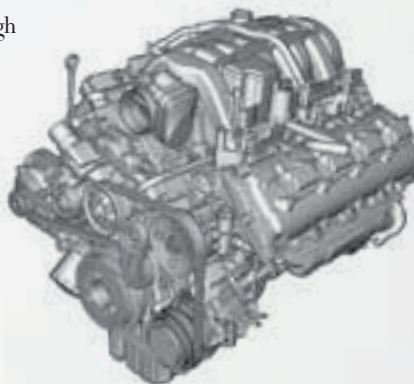

360

HORSEPOWER

390

LB-FT OF TORQUE

20

HWY MPG



GUARDIAN HERO.

PEACE OF MIND TAKES YOU AND YOURS FAR. THE 2012 JEEP® GRAND CHEROKEE IS ENGINEERED TO PERFORM HEROICALLY IN ALL DRIVING CONDITIONS. YOU'LL FEEL THE MIGHT OF ITS HIGH-STRENGTH STEEL STRUCTURE, SHELTERED WITHIN AN ENVIRONMENT THAT SERVES YOU WELL. GO BOLDLY FORTH, EMPOWERED WITH THE INSPIRED CONFIDENCE OF GRAND CHEROKEE.



ELECTRONIC STABILITY CONTROL (ESC).⁽⁶⁾

A vehicle-wide network of safety sensors help maintain vehicle control, providing instant aid should they detect you're veering off your intended path. ESC coordinates Electronic Roll Mitigation (ERM), antilock brake system (ABS) and Brake Assist, All-Speed Traction Control, and available Trailer Sway Control (TSC), sending them into action when needed.

PARKVIEW® AND PARKSENSE® PARK ASSIST SYSTEMS.⁽⁷⁾

Back out with grace. These systems help bring previously hidden rear objects to your attention, either on-screen or with an audible warning, in good time to react.

ADAPTIVE CRUISE CONTROL (ACC).⁽⁴⁾

The all-new ACC automatically adjusts cruising speed to maintain a preset distance between your Grand Cherokee and the crowd ahead.

SMARTBEAM™ HEADLAMPS WITH AUTO-LEVELING.

Brighter, better, safer. Bi-Xenon High Intensity Discharge (HID) headlamps shine up to three times brighter than regular headlamps. An auto-leveling feature keeps lamps focused down at the road ahead; lights automatically dim for oncoming traffic.

TRAILER SWAY CONTROL (TSC).⁽⁶⁾

Crosswinds and traffic hold no sway over you and your payload. As part of ESC, TSC helps keep you and the toys you are towing safely on course and under control.

RAIN-SENSING WIPERS AND RAIN BRAKE SUPPORT.

Storm clouds hold little influence over your daily drive. Front wipers activate when raindrops are detected and a new smart brake system helps dry the brake rotors on wet roads.



ACTIVE HEAD RESTRAINTS.⁽⁹⁾ A standard and effective safety feature that can help stave off neck injuries. Restraints automatically react and adjust to help provide protection during rear-impact collisions.

FORWARD COLLISION WARNING (FCW).⁽¹⁰⁾ Even the most attentive drivers will appreciate the help of this warning system. Approach another object too rapidly and Grand Cherokee lets you know so you can take appropriate action.

A SAFE, SECURE AIR BAG SYSTEM.⁽¹¹⁾ Always standard: full-length side-curtain, seat-mounted side thorax, and advanced multistage front air bags all work in tandem to help provide protection.

ELECTRONIC ROLL MITIGATION (ERM).⁽⁶⁾ If things get rough, Grand Cherokee's ERM takes immediate action to help you maintain stability and remain under control.

HILL DESCENT CONTROL (HDC)⁽⁶⁾ AND HILL START ASSIST (HSA). These systems are always at your beck and call when you need to get safely around the corner or up and down the mountain.

ANTILOCK BRAKE SYSTEM (ABS). The benefits of ABS on slippery, wet roads are widely known. This advanced system knows when you're driving over rough terrain and adjusts accordingly to help keep you in optimum control.

SENTRY KEY[®] ENGINE IMMOBILIZER. A unique, embedded key code matched only to your vehicle helps keep your Grand Cherokee safely where it belongs.

BLIND SPOT MONITORING⁽¹⁾ AND REAR CROSS-PATH DETECTION SYSTEM.⁽²⁾ These sentry systems constantly monitor the space between you and other drivers. When a side or rear blind spot is encroached, you're notified via illuminated icons on sideview mirrors or an audible chime.



IMPROVE YOUR
OUTLOOK.







INFORMED AND WELL-CONNECTED.

STAY IN TOUCH WITH THE PEOPLE, MUSIC, AND DEVICES THAT MATTER MOST. UCONNECT® IS AN INTUITIVE HUB FOR ALL YOUR MEDIA — CELL PHONE, INTERNET, SIRIUSXM™ SATELLITE RADIO,⁽³⁾ NAVIGATION SYSTEM, MP3 PLAYER, AND SMARTPHONE. YOU'LL STAY CONNECTED, INFORMED, ENTERTAINED, AND FOCUSED ON DRIVING WITH THIS USER-FRIENDLY SYSTEM.



PHONE. Talking on the phone while driving has never been easier — or more responsible. Uconnect Phone is the in-vehicle, voice-activated communication system that allows you to talk on your Bluetooth® compatible phone virtually hands-free. This clever system is also smart enough to synchronize with your Bluetooth compatible phone's address book⁽¹²⁾ — up to 1,000 entries — every time you get into your vehicle.



WEB. Put the power of high-speed Internet in your vehicle with Uconnect Web.⁽¹³⁾ Effortlessly connect any WiFi-enabled device to the Internet at 3G broadband speeds, making your vehicle a mobile Hotspot. Passengers can use multiple devices at the same time. There's no need for cell cards or software with this unique Authentic Accessory by Mopar — it's all wireless. Subscription required. Sold separately.



VOICE COMMAND. It simplifies driving by letting you keep your eyes on the road and your hands on the wheel. Use your voice to select AM/FM radio stations, SiriusXM Satellite Radio⁽³⁾ channels, or make calls. Select navigation destinations and record voice memos. This smart system technology can also be trained to better recognize your voice and can understand commands in English, French, and Spanish.



ENTERTAINMENT. Manage all of your media. You'll have several ways to access audio. Get the sound going via CDs/DVDs, MP3s, remote USB port, audio jack, hard disc storage, Voice Command, SiriusXM Satellite Radio⁽³⁾ (your first year of service is included), and Bluetooth streaming audio.



NAVIGATION. Provides enhanced GPS navigation and destination entry via voice command and SiriusXM Traffic™⁽³⁾ for real-time traffic information on the go. It can also locate nearby restaurants, shopping, hospitals, or points of local interest. Includes accident alerts, road closings, and traffic flow. Your first year of SiriusXM Traffic⁽³⁾ service is included.



MEDIA CENTER 730N CD/DVD/MP3 RADIO. Go anywhere, hear everything with this top-line system. Hands-free communication lets you safely talk on the phone, text, or operate the navigation/radio. It arrives loaded with SiriusXM Travel Link,^{TM (3)} SiriusXMTM Satellite Radio,⁽³⁾ SiriusXM Traffic,^{TM(3)} and Bluetooth[®] streaming audio.

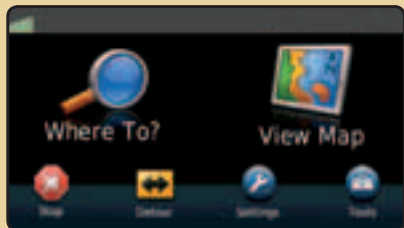

GARMIN.

GARMIN[®] NAV. Head out in the right direction with a media center that includes Garmin, the most recognized name in GPS wayfinding. It features Garmin's intuitive user interface and navigation with lane guidance, bringing the popular handheld experience to a factory in-dash screen.

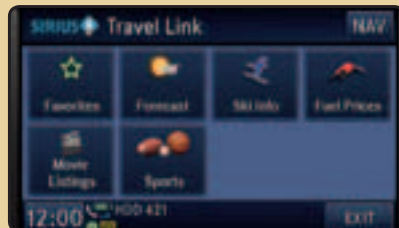

**SiriusXM
TRAVEL LINK**

SiriusXM TRAVEL LINK.⁽³⁾ Access a wealth of information at your fingertips, including national and local weather reports, local gas prices, in-game and final sports scores, weekly movie times, even local ski slope conditions. Subscription is required after one-year complimentary service.



SHOWN WITH: CHROMED GRILLE INSERT, CHROME FOG LIGHT BEZEL, 20-INCH CHROME WHEEL, CHROME TUBULAR SIDE STEPS, AND CHROME MIRROR COVERS.

AUTHENTIC JEEP® ACCESSORIES.



MOPAR® INSPIRES VEHICLE OWNERS WITH INNOVATIVE PARTS AND ACCESSORIES – ALL MADE-TO-SPEC FOR YOUR GRAND CHEROKEE. THIS IS WHAT MOPAR DELIVERS, ALONG WITH EXPERT, CARING SERVICE. MOPAR TECHNICIANS ARE THE MASTERS OF YOUR MAKE AND MODEL, WITH ACCESS TO THE TOOLS AND DIAGNOSTIC EQUIPMENT THAT HELP GET THE JOB DONE EFFICIENTLY AND EFFECTIVELY. CHOOSE AUTHENTIC MOPAR PARTS AND SERVICE, AND YOU’LL DRIVE AWAY WITH PEACE OF MIND. FIND OUT MORE AT MOPAR.COM.

AUTHENTIC JEEP ACCESSORIES BY MOPAR

SPORT. + No matter what adventure you seek, you’ll want to add to the sport of it all with durable and convenient Mopar carriers.

PROTECTION. + Safeguard your vehicle with parts and accessories made precisely for the protection and security of your ride.

STYLE. + Select from a palette of attractive accessories designed to enhance your vehicle’s appearance and express your individual taste.

INNOVATION. + From Uconnect Web to Ambient Light Kits, the latest of Mopar technology can enhance and expand your driving experience.



Properly secure all cargo.

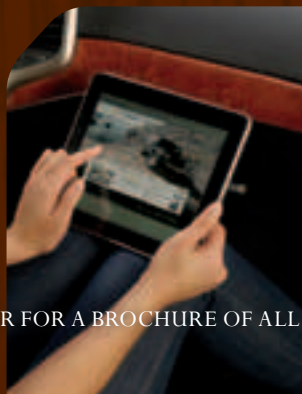

{ SEE YOUR DEALER FOR A BROCHURE OF ALL AUTHENTIC JEEP ACCESSORIES FOR GRAND CHEROKEE. }



TRUE TO THE CORE.

UNCOVER AN EXTENSIVE LINE OF FUN THAT'S BEEN DEVELOPED EXCLUSIVELY FOR THE JEEP® BRAND ENTHUSIAST. FROM AUTHENTIC WEARABLES TO UNIQUE GIFTS, ALL ITEMS ARE AS RUGGED AND DURABLE AS YOUR JEEP VEHICLE. SEE HOW YOU CAN LIVEN UP YOUR LIFE. VISIT JEEP.COM/GEAR.

Jeep.Gear





This brochure is a publication of Chrysler Group LLC. All product illustrations and specifications are based upon current information at the time of publication approval. Chrysler Group LLC reserves the right to make changes from time to time, without notice or obligation, in prices, specifications, colors, materials, and to change or discontinue models, which are considered necessary to the purpose of product improvement or for reasons of design and/or marketing. Jeep, the Jeep grille, Grand Cherokee, CommandView, Go Anywhere, Do Anything, Mopar, Overland, ParkSense, ParkView, Pentastar, Quadra-Drive, Quadra-Lift, Quadra-Trac I, Quadra-Trac II, Sentry Key, Selec-Terrain, SRT, SRT8, Trail Rated and Uconnect are registered trademarks and Tripcast are trademarks of Chrysler Group LLC. Bluetooth is a registered trademark of Bluetooth SIG, Inc. Chris-Craft is a registered trademark of Chris-Craft Corporation. Facebook is a trademark of Facebook, Inc. FIAT is a registered trademark of Fiat Group Marketing & Communications S.p.A., used under license by Chrysler Group LLC. Flickr is a trademark of Yahoo!, Inc. Garmin and the Garmin logo are registered trademarks of Garmin Ltd. or its subsidiaries and registered in one or more countries, including the U.S. iPhone and iTunes are registered trademarks and iPad is a trademark of Apple Inc. Pirelli is a registered trademark of Pirelli C.S.p.A. © 2011 Pirelli Tire North America. All rights reserved. SiriusXM and all related marks and logos are trademarks of SiriusXM Radio Inc. SmartBeam is a trademark of Gentex Corporation. Twitter is a service mark of Twitter, Inc. YouTube is a trademark of Google Inc.

⁽¹⁾ Always check visually for vehicles prior to changing lanes. ⁽²⁾ Always check entire surroundings visually before backing up. ⁽³⁾ SiriusXM services require subscriptions, sold separately after 12-month trial included with vehicle purchase/lease. Subscriptions governed by SiriusXM Customer Agreement at siriusxm.com. If you decide to continue your SiriusXM service at the end of your complimentary trial, the plan you choose will automatically renew and bill at then-current rates until you call SiriusXM at 1-866-635-2349 to cancel. SiriusXM U.S. satellite service available only to those at least 18 years of age in the 48 contiguous United States and D.C., with Sirius also available in PR. Go to www.siriusxm.com/traffic for available coverage. © 2011 SiriusXM Radio Inc. ⁽⁴⁾ ACC is a driver convenience system, not a substitute for active driver involvement. The driver must remain aware of traffic conditions and be prepared to use brakes to avoid collisions. ⁽⁵⁾ Based on 2011 *Ward's* segmentation. ⁽⁶⁾ No system, no matter how sophisticated, can repeal the laws of physics or overcome careless driving actions. Performance is limited by available traction, which snow, ice, and other conditions can affect. When the ESC warning lamp flashes, the driver needs to use less throttle and adapt speed and driving behavior to prevailing road conditions. Always drive carefully, consistent with conditions. Always wear your seat belt. ⁽⁷⁾ Do not attempt water fording unless depth is known to be less than 20 inches. Traversing water can cause damage that may not be covered by the new vehicle warranty. Always off-road responsibly in approved areas. ⁽⁸⁾ When equipped with available Trailer Tow Group. ⁽⁹⁾ Always sit properly with the head restraint properly adjusted. Never place anything in front of the head restraint. ⁽¹⁰⁾ FCW system is solely an alert system for the front of the vehicle which does not take any actions to change vehicle dynamics to avoid a collision, not a substitute for active driver involvement. The driver must remain aware of traffic conditions and be prepared to use brakes to avoid collisions. ⁽¹¹⁾ The Advanced Front Air Bags in this vehicle are certified to the new U.S. federal regulations for advanced air bags. Children 12 years old and younger should always ride buckled up in a rear seat. Infants in rear-facing child restraints should never ride in the front seat of a vehicle with a passenger front air bag. All occupants should always wear their lap and shoulder belts properly. ⁽¹²⁾ Phone must support Bluetooth Phone Book Access Profile (PBAP). ⁽¹³⁾ Uconnect Web feature is not intended for use by the driver while the vehicle is in motion. Always drive carefully. Subscription required. © 2011 Chrysler Group LLC. 74-383-2284

THE ADVENTURE NEVER ENDS.

JEEP® JAMBOREES. For those who are driven by an adventurous spirit, we invite you to join us on the trail. You can head for parts unknown or return to fun, familiar places. Jeep Jamboree USA offers off-road adventure weekends that bring together the outdoors, down-to-earth people, and their Jeep 4WD vehicles. We invite you to explore America's remote backcountry, where great friendships and memories are made.



TRIPCAST™ The Jeep brand invites you to enjoy this free and easy way to track the progress of your trips, post photos and videos, audio clips, and notes from the road to share with friends in real time. It automatically maps your trail using your Smartphone or iPhone® GPS capabilities. Link TripCast to your Facebook or Twitter account to post trip updates. Includes Points of Adventure, a database of over 250,000 activity spots, including parks, bike paths, camping areas, ski resorts, and more.

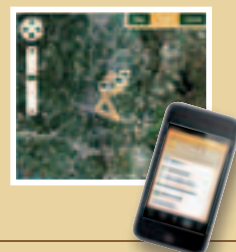

JEEP SOCIAL ADVENTURES. There's more to living the Jeep life when your horizons are expanded to include authentic and active Jeep online communities. Post stories, share photos, watch videos, and get the latest news from Jeep gearheads and engineers. Fellow Jeep enthusiasts are waiting to hear from you on Facebook ([facebook.com/Jeep](https://www.facebook.com/Jeep)), Twitter (twitter.com/Jeep), flickr ([flickr.com/Jeep](https://www.flickr.com/Jeep)) and on YouTube ([youtube.com/TheJeepChannel](https://www.youtube.com/TheJeepChannel)). Tune in, turn us on, and get out into the virtual world where thrilling adventures are happening every single day.



iPAD™ APPS. Steer your iPad over to the Chrysler Group LLC iTunes® store for a full selection of multimedia, fun-to-navigate vehicle apps. You'll find state-of-the-art, fully engaging, touch-based tours on the full lineup of Chrysler Group LLC and FIAT® rides. These robust apps serve up eye-popping and interactive graphics, heart-pumping videos, cool related content links, and detailed information on Chrysler Group LLC's finest automobiles, SUVs, and trucks. You'll enjoy the ride every time you visit.

treadlightly!
OFFICIAL SPONSOR



As a founding member and official partner, we urge all Jeep® owners to "Use common sense and stay on designated trails" and follow Tread Lightly! Guidelines, helping preserve the beauty of our landscape for generations to come. Call (800) 966-9900 or visit treadlightly.org to learn more.

TRAVEL RESPONSIBLY on designated roads and trails or in permitted areas.

RESPECT THE RIGHTS OF OTHERS, including private property owners and all recreational trail users, campers, and others, to allow them to enjoy their recreational activities undisturbed.

EDUCATE YOURSELF by obtaining travel maps and regulations from public agencies, planning for your trip, taking recreation skills classes, and knowing how to use and operate your equipment safely.

AVOID SENSITIVE AREAS such as meadows, lakeshores, wetlands, and streams, unless on designated routes. This protects wildlife habitat and sensitive soils from damage.

DO YOUR PART by leaving the area better than you found it, properly dispose of waste, minimize the use of fire, avoid the spread of invasive species, restore degraded areas, and join a local enthusiast organization.



Printed on 100% Recyclable Paper / Process Chlorine Free

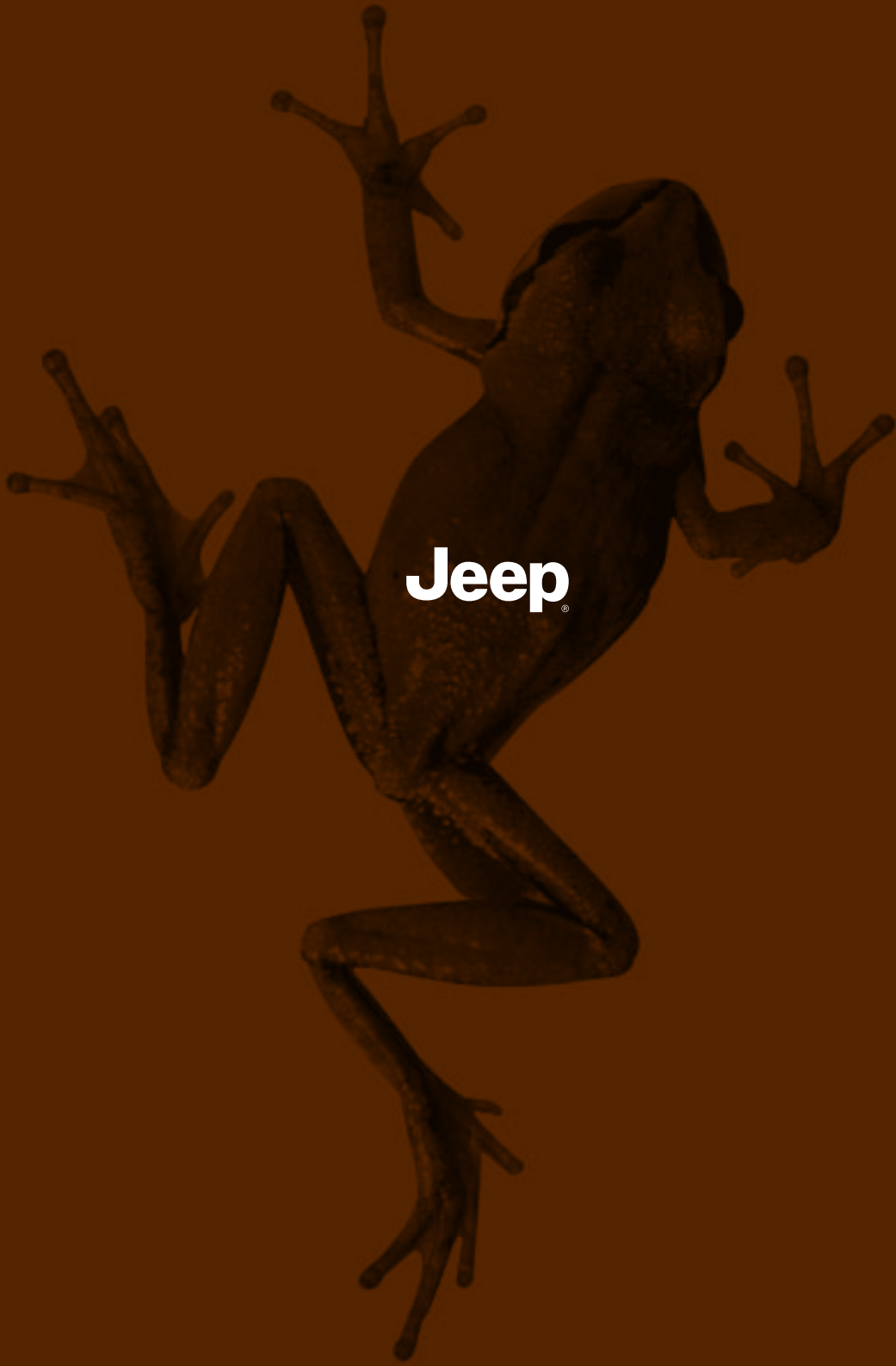

Jeep[®]

jeep.com

(800) 925-JEEP

Jeep is a registered trademark of Chrysler Group LLC.

jeep.com

(800) 925-JEEP

Jeep[®]

Jeep is a registered trademark of Chrysler Group LLC.

 Printed on Recycled Paper



2 0 1 3

Jeep[®]
G R A N D
C H E R O K E E

From lush valleys
to dynamic cities,
Grand Cherokee offers
a supremely capable
platform to engage and
expand your world.



GO MOBILE. Take an engaging, multimedia tour of your vehicle on your mobile device. Visit the Chrysler Group LLC page in iTunes® from your smartphone or iPad™ to download the most up-to-date apps on all of the company's vehicles. Log on to the jeep.com mobile site for a comprehensive, at-a-glance review of what you need to know about your Jeep® vehicle. Experience visual and interactive demonstrations of the entire lineup, gaining access to product information at your fingertips, wherever you go.

JEEP. SOCIAL ADVENTURES. Expand your horizons to include authentic and active Jeep online communities. Post stories, share photos, watch videos, and get the latest news from Jeep gearheads and engineers. Fellow Jeep enthusiasts are waiting to hear from you on Facebook (facebook.com/Jeep), Twitter (twitter.com/Jeep), Flickr (flickr.com/Jeep), and on YouTube (youtube.com/TheJeepChannel). Tune in, turn us on, and get out into the virtual world where thrilling adventures are happening every single day.

JEEP. JAMBOREES. For those who are driven by an adventurous spirit, we invite you to join us on the trail. You can head for parts unknown or return to fun, familiar places. Jeep Jamboree USA offers off-road adventure weekends that bring together the outdoors, down-to-earth people, and their Jeep 4WD vehicles. We invite you to explore America's remote backcountry, where great friendships and memories are made.

PINK LINE INDICATES INSERT POSITION

(1) Jeep Grand Cherokee has received more awards over its lifetime than any other SUV. (2) Based on latest available competitive information and World's segmentation. (3) Do not attempt water fording unless death known to be less than 20 inches. Traversing water can cause damage that may not be covered by the new vehicle warranty. Always off-road responsibly in approved areas. (4) A/C is a driver convenience system, not a substitute for active driver involvement. The driver must remain aware of traffic conditions and be prepared to use brakes to avoid collisions. (5) When equipped with available Trailer Tow Group. (6) No system, no matter how sophisticated, can repeal the laws of physics or overcome careless driving actions. Performance is limited by available traction, which snow, ice, and other conditions can affect. When the ESC warning lamp flashes, the driver needs to use less throttle and adapt speed and driving behavior to prevailing road conditions. Always drive carefully, consistent with conditions. Always wear your seat belt. (7) SiriusXM service requires a subscription, sold separately after 12-month trial included with vehicle purchase. **If you decide to continue your SiriusXM service at the end of the trial subscription, the plan you choose will automatically renew and bill at the current rates until you call SiriusXM at 1-866-635-2349 to cancel.** See our Customer Agreement for complete terms at siriusxm.com. Sirius satellite service is available only to those at least 18 and older in the 48 contiguous United States, D.C., and P.R. (with coverage limitations). SiriusXM Traffic available in select markets. See siriusxm.com/traffic for more information. Sirius, XM and all related marks and logos are trademarks of SiriusXM Radio Inc. (8) iPhone must support Bluetooth Phone Book Access Profile (PBAP). (9) Unconnect Web feature is not intended for use by the driver while the vehicle is in motion. Always drive carefully. Subscription required. (10) Always check mirrors surrounding visually before reversing. (11) Always sit properly with the head restraint properly adjusted. Never place anything in front of the head restraint. (12) ECW system is solely an alert system for the front of the vehicle which does not take any actions to change vehicle dynamics to avoid a collision, but a substitute for active driver involvement. The driver must remain aware of traffic conditions and be prepared to use brakes to avoid collisions. (13) The Advanced Front Air bags in this vehicle are certified to the new U.S. federal regulations for advanced air bags. Children 12 years old and younger should always ride buckled up in a rear seat. Infants in rear-facing child restraints should never ride in the front seat of a vehicle with a passenger front air bag. All occupants should always wear their lap and shoulder belts properly. (14) Always check visually for vehicles prior to changing lanes.

This brochure is a publication of Chrysler Group LLC. All product illustrations and specifications are based upon current information at the time of publication approval. Chrysler Group LLC reserves the right to make changes from time to time, without notice or obligation, in prices, specifications, colors, materials, and to change or discontinue models, which are considered necessary to the purpose of product improvement or for reasons of design and/or marketing. Chrysler, Jeep, the Jeep grille, Grand Cherokee, CommandView, HEMI, J-40, Laredo, Mopar, Overland, Overland Summit, ParkSense, ParkView, Pentastar, Quadra-Drive, Quadra-Lift, Quadra-Trac, Quadra-Trac II, Sentry Key, Selec-Terrain, Selec-Track, SRT, Trailhawk, Trail Rated, Uconnect, and Go Anywhere, Do Anything are registered trademarks of Chrysler Group LLC. Alpine and the Alpine logo are registered trademarks of Alpine Electronics, Inc. All rights reserved. Bluetooth is a registered trademark of Bluetooth SIG, Inc. Brembo is a registered trademark of Brembo S.p.A. Facebook is a registered trademark of Facebook, Inc. Flickr is a registered trademark of Flickr, Inc. Garmin and the Garmin logo are registered trademarks of Garmin Ltd. or its subsidiaries and registered in one or more countries including the U.S. Goodyear is a registered trademark of The Goodyear Tire & Rubber Company. Hummel is a registered trademark owned by Johnson Controls, Inc. iPad, iPod, and iTunes are registered trademarks of Apple Inc. Martha Stewart is a trademark of Martha Stewart Living Omnimedia, Inc. All rights reserved. NASCAR is a registered trademark of the National Association for Stock Car Auto Racing, Inc. NFL is a registered trademark of the National Football League. Sirius, XM, and all related marks and logos are trademarks of SiriusXM Radio Inc. The Twitter name, logo, Twitter 'T', Tweet, and Twitter bird are trademarks of Twitter, Inc. in the United States and other countries. YouTube is a registered trademark of Google Inc. © 2012 Chrysler Group LLC. All rights reserved.

THE ART OF BEING RESOURCEFUL

DELVE DEEPER INTO GRAND CHEROKEE BY
EXPLORING THE ENCLOSED BUYER'S GUIDE
OR VISITING US ON THE WEB. THE JEEP® BRAND
OFFERS AN EXPANSIVE ARRAY OF SOCIAL MEDIA,
SHOPPING, AND OWNER RESOURCES. PLUS, DISCOVER
ONE-OF-A-KIND EVENTS THAT CAN CREATE LIFELONG
CONNECTIONS WITH LIKE-MINDED FRIENDS. EXPAND YOUR
ADVENTURES IN EVERY DIRECTION BY VISITING **JEEP.COM.**



GRAND CHEROKEE
COMPLEMENTS
THE LANDSCAPE
OF YOUR LIFE



» ACCOMPANIED BY GRAND CHEROKEE, THE MOST AWARDED SUV EVER,^{1*} THERE'S PROMISE AROUND EVERY CORNER. YOU'VE ARRIVED AT THE PINNACLE OF LUXURY, APPOINTED WITH ADVANCED TECHNOLOGY AND FULLY REALIZED JEEP® BRAND CAPABILITY. THE ADVENTURE HAS BEGUN AND YOU'RE SUPREMELY PREPARED TO LIVE WELL.

*A note about this brochure: All disclaimers and disclosures can be found on the inside back cover.

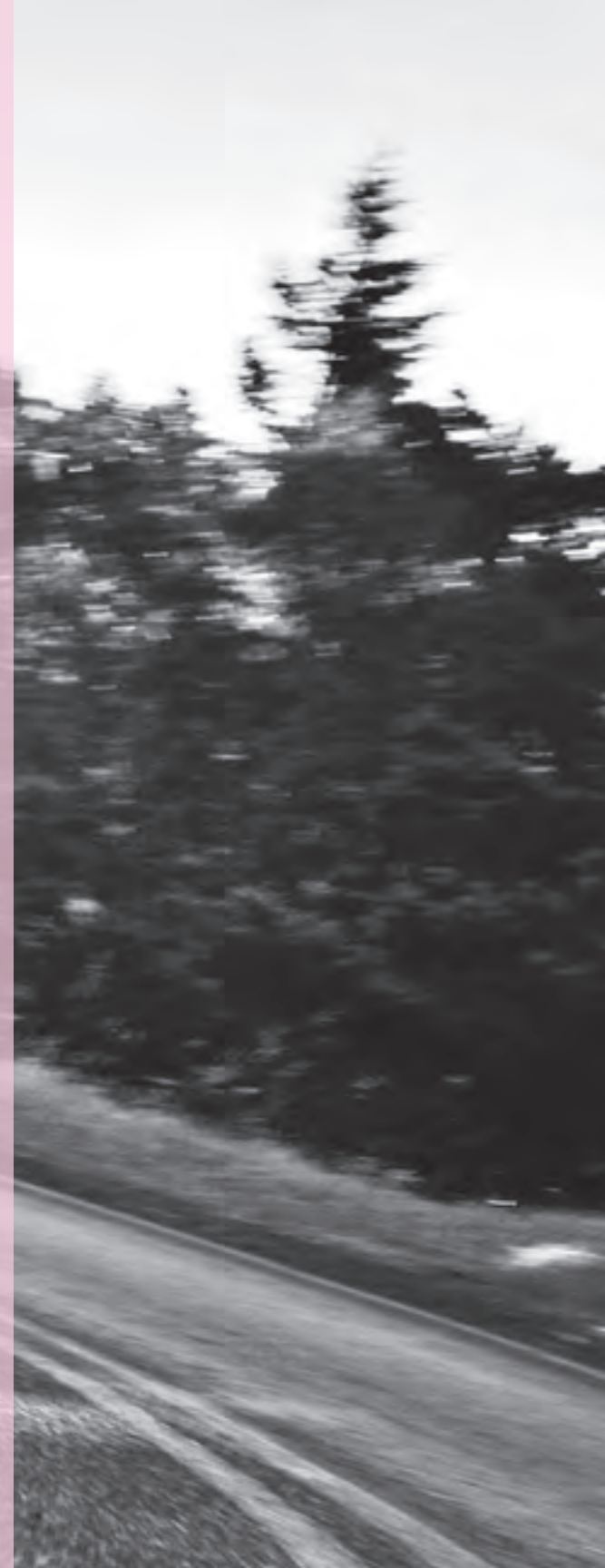



Sculpted to achieve exemplary marks in aerodynamics, Grand Cherokee's exterior surfaces exude timeless style and grace.





» **JEEP SELEC-TERRAIN® TRACTION MANAGEMENT SYSTEM.** Revel in the challenge of all-weather driving. When road conditions suddenly change, this available traction management and torque distribution system lets you adjust accordingly to help you keep moving forward safely.

» **INDEPENDENT SUSPENSION.** The isolated cradles in Grand Cherokee's front and rear suspension systems help absorb troubling bumps as if they were never in your way.

» **SMOOTH STEERING.** Grand Cherokee's electrohydraulic power steering provides the natural, smooth feel of a sophisticated conventional hydraulic power steering system while simultaneously helping to improve efficiency by using electric power instead of drawing power from the engine.

» **HEADLAMP WASHER SYSTEM.** Poor visibility during inclement weather is a real safety issue. Overland Summit® works to help maintain clear night vision by keeping your headlamps free of mud, ice, and debris.

ALL-WEATHER GLAMOROUS



RISE TO THE OCCASION

CLASS-EXCLUSIVE² **QUADRA-LIFT**[®] AIR SUSPENSION

FINELY TUNED TECHNOLOGIES MERGE FOR ULTIMATE RIDE-HEIGHT CONTROL. ONE TOUCH GAINS YOU MASTERY OF THE TERRAIN BELOW.

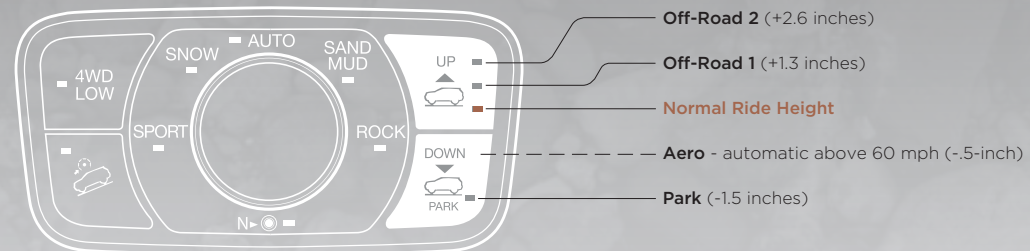

PARK MODE



Make a graceful entrance and take an elegant leave. Lower Grand Cherokee 1.5 inches for easier vehicle entry, exit, and loading.

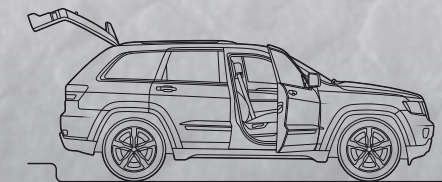

AERO MODE



Without touching a single button, improved aerodynamics come courtesy of an automatic drop in ride height of ½ inch at 60 mph or above.



OFF-ROAD 1 MODE



By adding 1.3 inches, you gain the altitude that can help clear obstacles and gain passage during off-road travels.



OFF-ROAD 2 MODE



Best-in-class³ ground clearance of 10.7 inches is achieved by raising 2.6 inches to tackle conditions beyond the everyday.



EXQUISITELY LEADS



FIVE PERFORMANCE TEST CATEGORIES are designed to prove every Jeep vehicle's Trail Rated® capability.

» **TRACTION.** Trail Rated traction helps you maintain controlled forward motion on snowy back roads and icy bridges. You can climb steep sand dunes and master muddy two-tracks. Others may fear untamed terrain, but your Trail Rated Grand Cherokee has the traction within to master all kinds of topography and driving conditions.

» **ARTICULATION.** Grand Cherokee's suspension systems enhance on- and off-road performance by maximizing flexibility, axle articulation, and wheel travel. This standard indicates that when one or more wheels are elevated, the Jeep 4x4 system helps the others stay on the ground longer to keep you moving.

» **MANEUVERABILITY.** Every Grand Cherokee is born with the athletic ability to navigate narrow gaps, dodge emergency situations, and avoid cosmetic damage to underbody sills, thanks to precision steering and optimized wheelbases.

» **GROUND CLEARANCE.** Head out knowing that your Trail Rated Grand Cherokee has optimized approach, departure, and breakover angles designed to clear logs, rocks, and uneven ground. Your undercarriage is protected, too, with forged skid plates that cover your vehicle's most valuable underbody elements.

» **WATER FORDING.²** Traverse up to 20 inches of water with confidence, thanks to additional electrical and body seals, plus a high air-intake location. Of course, always inspect all waterways before proceeding, just to make sure there are no unforeseen pitfalls.



It's the recognized standard for off-road capability. The available Trail Rated[®] fortitude of Jeep Grand Cherokee helps you navigate the world and all it offers. On the road or on the trail, Grand Cherokee works to safely get you through the challenges Mother Nature sets before you.







OVERLAND SUMMIT[®] transports all who enter to a place above all others. The cabin is altogether luxurious, with a premium hand-stitched leather-trimmed interior available in your choice of either New Saddle or the new and very classic Black with contrasting stitching. The iconic Overland Summit logo is elegantly presented on the front leather-trimmed seats. Real wood trim adorns the leather-wrapped steering wheel, front instrument panel, and doors. Standard amenities abound, and optional features offer plentiful opportunities to elevate your driving experience to the very peak of indulgence.



BEHOLD THE PINNACLE OF LUXURY. OVERLAND SUMMIT[®] IS THE MOST MAJESTIC JEEP[®] 4x4 EVER CRAFTED. POWERFULLY CAPABLE. TECHNOLOGICALLY SUPERIOR. BEAUTIFULLY REFINED.



////ALPINE

» **IMMERSIVE SOUND.** Alpine® delivers an available premium audio system that utilizes a high-powered 12-channel, 506-watt amplifier powering nine speakers and a subwoofer, optimally placed throughout the cabin.

» **CARRY-ON WITH EASE.** Configure your interior to suit the situation. The available power liftgate opens to reveal a large rear cargo area with 60/40 split rear seat and fold-flat front-passenger seat.

» **ADAPTIVE CRUISE CONTROL.*** This safety feature automatically adjusts cruising speed to maintain a preset distance between you and the vehicle ahead. Available.

» **CLIMATIZED FOR COMFORT.** Dual-Zone Automatic Temperature Control (ATC) constantly adjusts the air temp inside the cabin to create a customized environment. Available.

» **HEATED AND VENTILATED FRONT SEATS.** Add quick warmth on cool days and welcome relief when temps rise — a small fan gently circulates cool air via perforations within the seat coverings. Available.

» **EN ROUTE ENJOYMENT.** The Rear DVD Entertainment Group includes rear-seat video screen, overhead console, sunroof, two wireless headphones, and remote control. Available.

DISTINGUISHED TRAVELER REWARDING PERKS



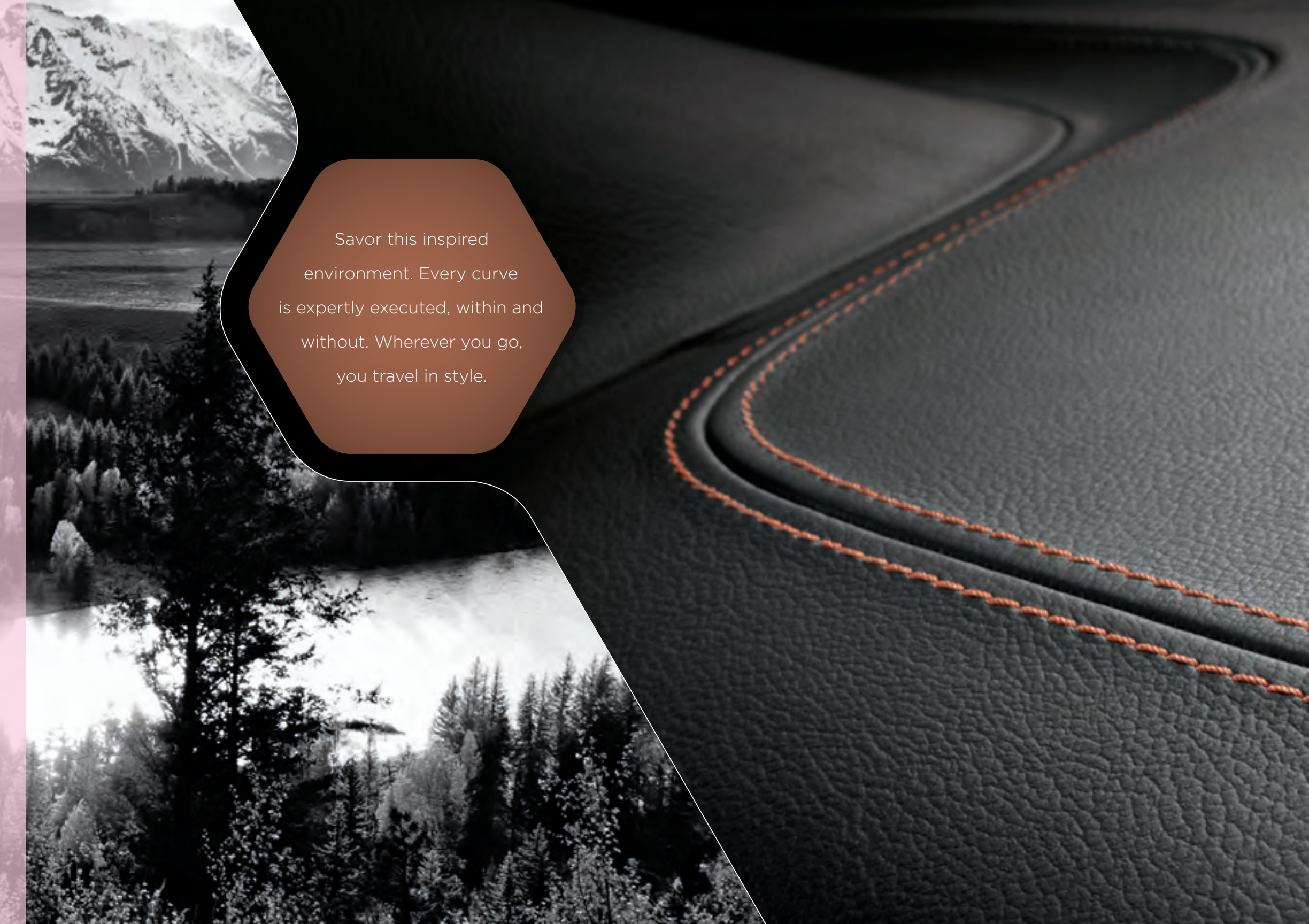

Savor this inspired environment. Every curve is expertly executed, within and without. Wherever you go, you travel in style.



Jeep® Grand Cherokee takes its cues from the ultimate source — the world in which we thrive. Throughout, you will find luxurious appointments expressed in details that are designed to inspire and engineered to endure.

DETAIL OF ICONIC JEEP GRILLE WITHIN INNER LAMP

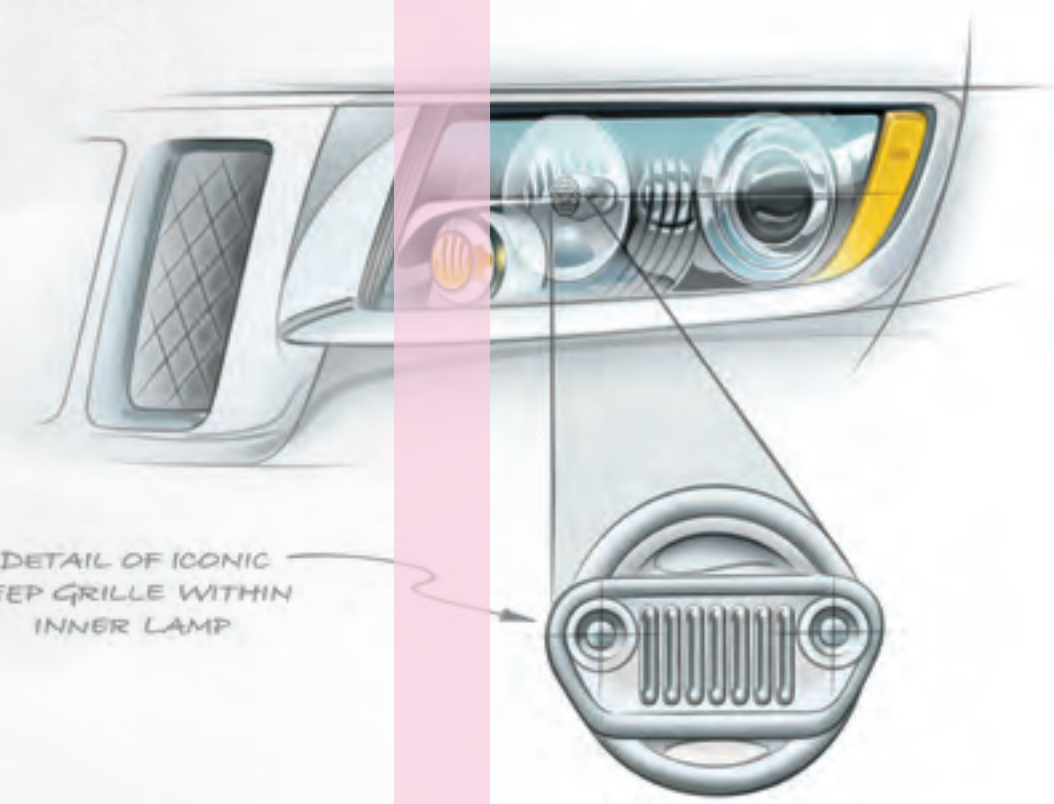

WHEN DETAILS EXCEED EXTRAORDINARY EXPECTATIONS

REAL WOOD. PREMIUM LEATHER. SATIN CHROME. CAST ALUMINUM WHEELS. FROM THE CRAFTSMANSHIP OF HAND-STITCHING ON ITS LEATHER-TRIMMED STEERING WHEEL TO THE CLEVER INCLUSION OF THE ICONIC JEEP® GRILLE WHERE YOU MIGHT LEAST EXPECT IT, THESE ARE THE DETAILS THAT PLACE YOU FIRMLY AT THE FRONT OF A VERY THRILLING WORLD-CLASS EXPERIENCE.





» **TIMELESS DESIGN.** A chiseled profile and ideal proportions result in equally impressive aerodynamics. Adorned with an iconic seven-slot grille and trapezoidal wheel arches, its fit and finish are executed with crafted precision. Short overhangs, high ground clearance, and a wide stance help crown Grand Cherokee as a king of capability.



» **ABUNDANT COMFORT.** A bounty of world-class treatments, hand-stitchings, chrome fittings, and softly sculpted surroundings transport Grand Cherokee passengers in unmatched luxury. Among the available options are leather-trimmed interiors, heated and ventilated seats, and a variety of advanced technology options, including navigation, Voice Command, CommandView® dual pane sunroof, and Dual Zone Automatic Temperature Control.

ITS NATURAL ABILITY IS QUITE COMPLEX

WITHIN GRAND CHEROKEE'S SCULPTED SKIN, JEEP® 4x4 PROWESS MEETS UPSCALE COMFORT. ITS HUSHED CABIN HELPS STOP ROAD NOISE IN ITS TRACKS. ITS CONTROLLED CORNERING REFLECTS THE MOST POLITE OF ROAD MANNERS. ITS EXACTING FIT AND FINISH IS IMPRESSIVE.

» **PENTASTAR® 3.6L V6 ENGINE.** The Pentastar cranks out enough power to tow up to 5,000 lb² and the efficiency to achieve a best-in-class² nod for 550 miles-per-tank range.* Dual overhead camshafts (DOHC) and structural refinements allow it to achieve an EPA estimated 17 city/23 highway mpg.

» **5.7L V8 HEMI® ENGINE.** This available workhorse churns out best-in-class² 360 horsepower and a brawny 390 lb-ft of torque. It is also strong enough to tow up to 7,400 lb². Fuel Saver Technology revamps this eight-cylinder engine during cruising speeds, turning it into a four-cylinder model of efficiency. It can seamlessly alternate between modes, and when you step on the pedal, all eight cylinders quickly roar back to life.

» **SELEC-TERRAIN.*** Choose from five different modes that adjust to current road conditions. Selec-Terrain coordinates many systems at once, including Hill Start Assist (HSA), Hill Descent Control, Electronic Stability Control (ESC),² as well as the transmission, differentials, and engine, to provide superior traction at all times.

» **QUADRA-DRIVE® II.** Capability is at hand with this available 4WD system. An Electronic Limited-Slip Differential (ELSD) transfers up to 100 percent of torque to the wheel(s) with traction, always working to help keep you moving forward.

» **QUADRA-TRAC II.*** An optional 4WD system offers all-speed traction control that helps keep you on course. If wheel slippage occurs, torque can be routed to the axle with the most traction. Low range provides rock-crawling prowess.

» **QUADRA-TRAC I.*** This fully automatic, available 4WD system requires no driver interaction. A single-speed transfer case offers a continual balance of torque distribution; if wheel slippage occurs, the system seamlessly transfers torque to the axle with traction.

» **QUADRA-LIFT.*** Fingertip control allows you to easily raise your vehicle higher for a maximum available best-in-class² ground clearance of 10.7 inches above ridges and rocks. Or lower it 1.5 inches for easier entry, exit, and loading. This closed-air suspension system uses four-corner air springs that help provide a cushioned and comfortable ride at every altitude.

» **SUSPENSION SYSTEMS.** Independent front and rear suspensions provide a greater sense of precision and control. Isolated cradles help absorb all the irregularities that roads and trails offer up.

» UNRIVALED ENGINEERING.

Whether you prefer the 5.7L V8 engine for its best-in-class² available hp and torque or the efficient 3.6L Pentastar® V6 that can travel over 500 miles on a single tank, both are matched to a smooth-shifting 5-speed automatic transaxle and your choice of three Jeep® brand-engineered 4WD systems. At the same time, independent front and rear suspension systems deliver a ride reminiscent of the priciest sedans.

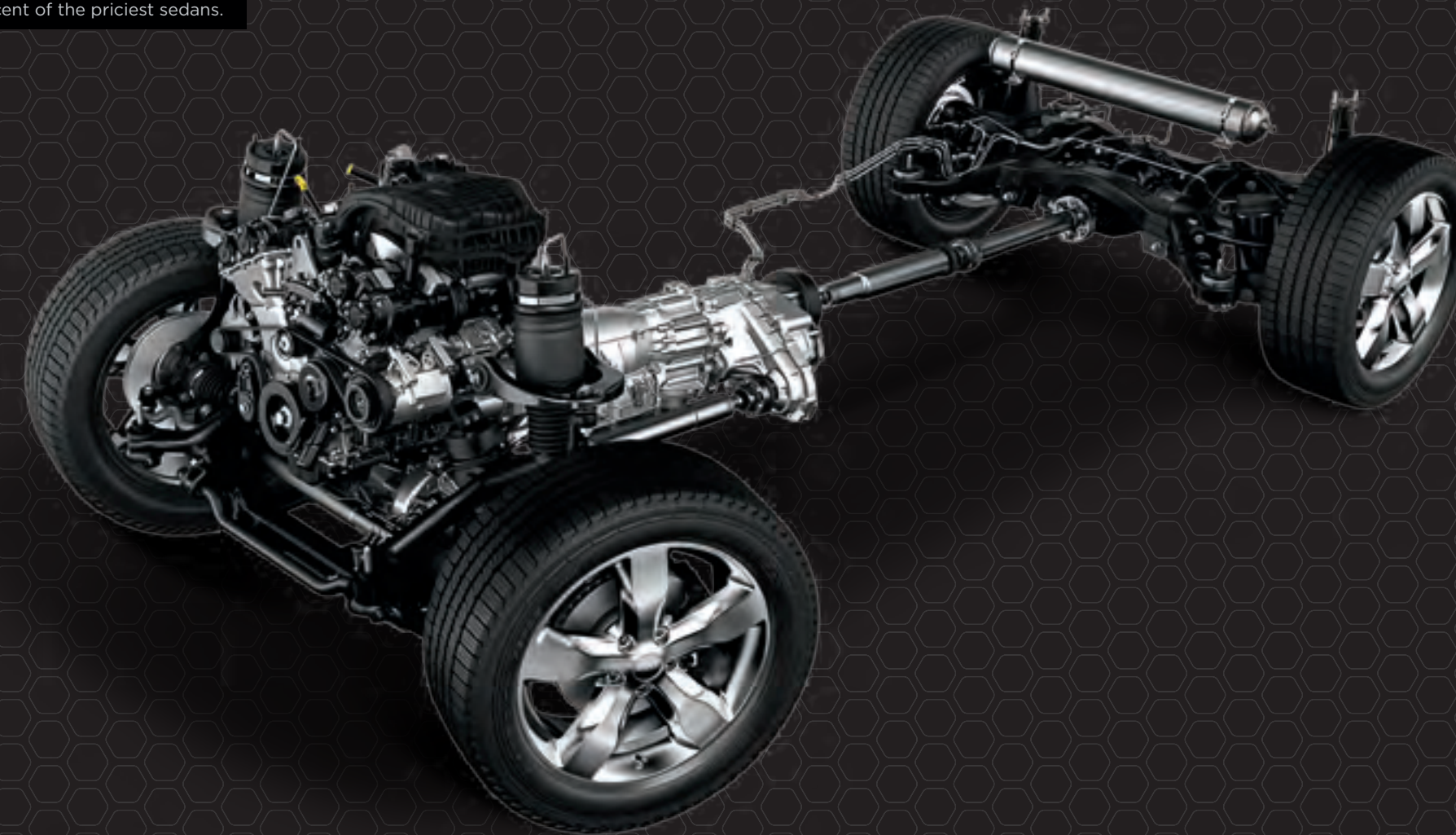

*Based on *Ward's* segmentation, latest available competitive information, an EPA estimated 17 city/23 hwy mpg, and a 24.6-gallon fuel tank.

INGENIOUS ACCLIMATION



SELEC-TERRAIN®

Optimal on- and off-road traction is instantly at hand.

Five selectable settings electronically coordinate 12 different vehicle systems to adjust your traction control to match the road ahead. Whether you're caught on snow-covered city streets or climbing backcountry hills, Selec-Terrain actively manages torque distribution where others may not.



QUADRA-LIFT®

A revolutionary available class-exclusive² system that gives you ultimate control of your suspension. It allows you to easily raise your vehicle higher for a maximum available best-in-class³ ground clearance of 10.7 inches above ridges and rocks. Or with an easy push of a button, your vehicle is lowered 1.5 inches for easier entry, exit, and loading.

DOUBLE VISIONARY



CAPTURE THIS VIEW FROM THE TOP AND YOU'RE LIKELY TO SEE THINGS OTHERS MAY NOT. GRAND CHEROKEE'S AVAILABLE COMMANDVIEW® PANORAMIC SUNROOF PRESENTS AN INTERIOR AND EXTERIOR LANDSCAPE THAT IS ALL ENCOMPASSING. TO WIT: A FULL-POWER SUNROOF WITH A POWER SUNSHADE IN FRONT AND A FIXED GLASS WINDOW IN THE REAR. ONE LOOK AT THIS DUAL-PANED SLIDING-GLASS CEILING AND YOU'LL DEFINITELY GRASP THE UNDENIABLE BEAUTY OF WHAT RISES ABOVE.



THE REAL WORLD

WITHIN THE BEAUTIFUL CONFINES OF GRAND CHEROKEE YOU'LL FIND THE HONEST TRUTH OF PREMIUM NATURAL ELEMENTS, EXACTLY EXECUTED, CAREFULLY INTEGRATED. THEY EXIST TO REMIND YOU: THE MICROCOSM REFLECTS THE MACROCOSM. HOW YOU LIVE YOUR LIFE ON THE ROAD SPEAKS VOLUMES.



INTERACTION

UCONNECT® BRINGS A RANGE OF COMMUNICATION AND ENTERTAINMENT SERVICES STRAIGHT INTO YOUR VEHICLE, ALL BUNDLED TOGETHER WITHIN A ROBUST UCONNECT SYSTEM. WITH SO MANY CONVENIENT OPTIONS TO CHOOSE FROM, DISCOVER HOW YOU'D LIKE TO CONNECT AT DRIVEUCONNECT.COM.



GARMIN® GARMIN® NAV. Head out in the right direction with Garmin, the most recognized name in GPS wayfinding. It features Garmin's intuitive user interface and navigation with lane guidance, bringing the popular handheld experience to a factory in-dash screen.

SiriusXM TRAVEL LINK SiriusXM TRAVEL LINK.™ Access a wealth of information at your fingertips, including national and local weather reports, local gas prices, in-game and final sports scores, weekly movie times, even local ski slope conditions. Your first year of service is included.

SiriusXM SIRIUS SELECT™ - OVER 130 CHANNELS. This is what satellite radio is all about. Enjoy commercial-free music, plus sports, news, talk and entertainment. And get a selection of premium programming, including every NFL® game, Howard Stern, every NASCAR® race, Martha Stewart and more. Visit siriusxm.com for details.



» **ENTERTAINMENT.** Manage all of your media. You'll have several ways to access audio. Get the sound going via CDs/DVDs, MP3s, remote USB port, auxiliary input jack, hard disc storage, Voice Command, SiriusXM Satellite Radio® (your first year of service is included), and Bluetooth® streaming audio.

» **PHONE.** Talking on the phone while driving has never been easier — or more responsible. Uconnect Phone is the in-vehicle voice-activated communication system that allows you to talk on your Bluetooth compatible phone virtually hands-free. This clever system is also smart enough to synchronize with your Bluetooth compatible phone's address book® — up to 1,000 entries — every time you get into your vehicle.

» **NAVIGATION.** Provides enhanced Garmin, GPS navigation and destination entry via Voice Command; find a restaurant, airport, museum, or department store, and get directions with a simple request. Lane assist and junction view are also displayed.

» **VOICE COMMAND.** It simplifies driving by letting you keep your eyes on the road and your hands on the wheel. Use your voice to select AM/FM radio stations, SiriusXM Satellite Radio® channels, and make calls.

» **WEB.** Put the power of high-speed Internet in your vehicle with Uconnect Web.™ Effortlessly connect any WiFi-enabled device to the Internet at broadband speeds, making your vehicle a mobile hotspot. Passengers can use multiple devices at the same time. There's no need for cell cards or software with this unique Authentic Accessory by Mopar.™ — it's all wireless. Subscription required. Sold separately.

Learn more at driveuconnect.com.

LIVE
FROM
THE
INSIDE
OUT





» **EFFORTLESS ACCESS.** Designed for beauty as well as ultimate utility, the available power liftgate adds graceful accessibility to Grand Cherokee's rear cargo area. Keyless Enter 'n Go is hands-free via the key fob, so you can keep hold of what's in your hands without fumbling to unlock the gate.

» **COPIOUS COMFORT.** Passengers in the second row get first-row treatment with best-in-class² rear leg room, available heated seats offering instant warmth when the temperatures dip, and a reclining feature that allows passengers to make customized seatback adjustments of up to 12 degrees rearward for ultimate comfort.

» **AMPLE CARGO SPACE.** A variety of seating configurations give you plenty of options for carrying people, pets, and possessions. With the rear seat up, there's a full 36.3 cubic feet of space available. When the rear seats are folded down, there's a generous 68.3 cubic feet of capacity. The cargo area sports protective Chrome runners and four integrated tie-down loops.

» **HIDDEN GEMS.** A removable, rechargeable flashlight integrates into the rear cargo area within easy reach. Underneath the cargo floor are removable dual storage bins. Up front, personal storage abounds with driver and passenger-side cubbies, map pockets, cavernous glove box, center console, and covered center stack bin to keep valuables safely out of sight.



360° GUARDIAN

SURROUND YOURSELF WITH AN ARSENAL OF THE LATEST AVAILABLE SAFETY TECHNOLOGIES. JEEP® GRAND CHEROKEE TAKES YOU AND YOURS FAR WITH PEACE OF MIND, IN ALL DRIVING CONDITIONS. IT HEROICALLY KEEPS YOU SHELTERED WITHIN AN ENVIRONMENT THAT SERVES YOU WELL. GO FORTH WITH CONFIDENCE.

Insurance Institute for Highway Safety Top Safety Pick for 2012

ELECTRONIC STABILITY CONTROL (ESC).³ A vehicle-wide network of safety sensors helps maintain vehicle control, providing instant aid should they detect you're veering off your intended path. ESC coordinates Electronic Roll Mitigation (ERM), antilock brake system (ABS) and Brake Assist, all-speed traction control, and available Trailer Sway Control (TSC), sending them into action when needed.

PARKVIEW® AND PARKSENSE® PARK ASSIST SYSTEMS.¹⁰ Back out with grace. These systems help bring previously hidden rear objects to your attention, either on-screen or with an audible warning, in good time to react.

ADAPTIVE CRUISE CONTROL (ACC).⁴ The ACC automatically adjusts cruising speed to maintain a preset distance between your Grand Cherokee and the vehicle ahead.

AUTO HIGH BEAM HEADLAMP CONTROL. Brighter, better, safer. Bi-Xenon High Intensity Discharge (HID) headlamps shine up to three times brighter than regular headlamps. An auto-leveling feature keeps lamps focused down at the road ahead; lights automatically dim for oncoming traffic.

TRAILER SWAY CONTROL (TSC).⁵ Crosswinds and traffic hold no sway over you and your payload. As part of ESC, TSC helps keep you and the toys you are towing safely on course.

RAIN-SENSING WIPERS AND RAIN BRAKE SUPPORT. Storm clouds hold little influence over your daily drive. Front wipers activate when raindrops are detected, and a smart brake system helps dry the brake rotors on wet roads. Headlamp washers are standard on Overland Summit® and help maintain safe viewing of the road ahead at night.

ACTIVE HEAD RESTRAINTS.¹¹ A standard and effective safety feature that can help stave off neck injuries. Restraints automatically react and adjust to help provide protection during rear-impact collisions.

FORWARD COLLISION WARNING (FCW).¹² Even the most attentive drivers will appreciate the help of this warning system. Approach an object too rapidly and Grand Cherokee lets you know so you can take appropriate action.

A SECURE AIR BAG SYSTEM.¹³ Always standard: full-length side-curtain, seat-mounted side thorax, and advanced multistage front air bags all work in tandem to help provide protection.

ELECTRONIC ROLL MITIGATION (ERM).¹⁴ If things get rough, ERM takes immediate action to help you maintain stability and remain under control.

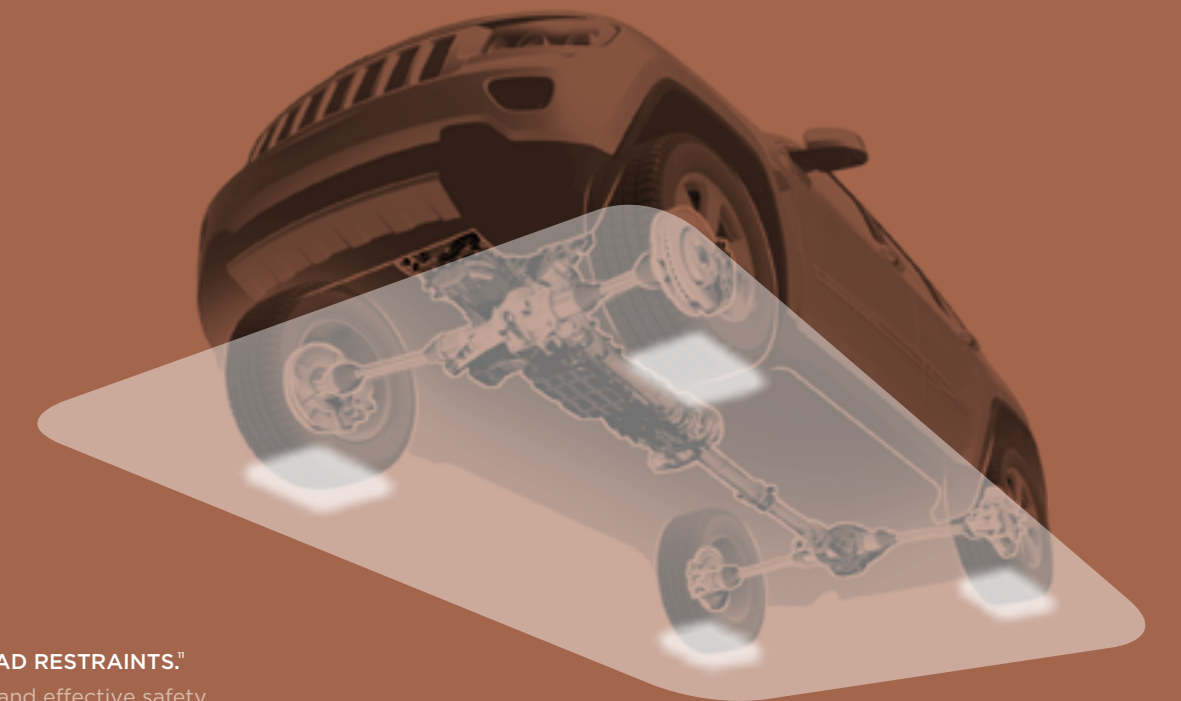

HILL DESCENT CONTROL AND HILL START ASSIST (HSA).¹⁵ These systems are always at your beck and call when you need to get safely around the corner or up and down the mountain.

ANTILOCK BRAKE SYSTEM (ABS).¹⁶ The benefits of ABS on slippery, wet roads are widely known. This advanced system knows when you're driving over rough terrain and adjusts accordingly to help keep you in optimum control.

SENTRY KEY® ENGINE IMMOBILIZER.¹⁷ A unique, embedded key code matched only to your vehicle helps keep your Grand Cherokee safely where it belongs.

BLIND SPOT MONITORING™ AND REAR CROSS-PATH DETECTION SYSTEM.¹⁸ These sentry systems constantly monitor the space between you and other drivers. When a side or rear blind spot is encroached, you're notified via illuminated icons on sideview mirrors or an audible chime.

FRONT PARK ASSIST.¹⁹ Grand Cherokee's new available Front Park Assist system helps you nestle into parking spots by detecting objects in front of the vehicle and providing an audible warning when your proximity is too close for comfort.

SRT



An exotic four-wheel-drive thrill machine, maxed out to put out. Turn heads with every turn, on the street or on the track.

GRAND CHEROKEE SRT.® THE MOST POWERFUL AND TECHNOLOGICALLY ADVANCED JEEP. VEHICLE ON THE PLANET BEARS A 470-HP 6.4L HEMI® SRT® V8 ENGINE, A QUADRA-TRAC® ACTIVE ON-DEMAND 4WD SYSTEM, AN ADAPTIVE DAMPING SUSPENSION, AND A BREMBO® SRT ANTILOCK BRAKE SYSTEM WITH ALL-OUT STOPPING POWER. THE RACE-INSPIRED INTERIOR FEATURES EXCLUSIVE SUEDE-ACCENTED, LEATHER-TRIMMED SEATING AND A HEATED, FLAT-BOTTOM STEERING WHEEL. IT'S ALL THIS, AND SO MUCH MORE. FULL SPECS AT driveSRT.COM.



GROWLS
BEFORE
IT BITES







LAREDO

Laredo arrives with all the standard finery that makes Grand Cherokee a world-class traveler. It takes to the road with the hushed ride of a stealth machine, thanks in part to double-dash construction and surrounding glass. A best-in-class* driving range of 550 miles* gives you plenty of time to enjoy all of the scenery between fill-ups.

STANDARD

- > Pentastar® 3.6L V6 engine
- > Quadra-Trac I® 4WD system (4x4 models only)
- > 5-speed automatic transmission with Electronic Range Select
- > UniFrame construction
- > Electronic Stability Control (ESC)®
- > Tinted glass
- > Fog lamps
- > Rear liftgate flipper glass
- > Power, manual foldaway, heated body-color mirrors
- > Roof rack with bright side rails
- > Dual-Zone Temperature Control
- > Keyless Enter 'n Go
- > Remote key fobs
- > Cloth seats

> Uconnect® 130 AM/FM/CD/MP3

- > Front fold-flat passenger seat
- > Leather-wrapped steering wheel
- > Cruise control
- > 17-inch cast aluminum wheels
- > Advanced multistage driver and front-passenger air bags†
- > Advanced side-curtain air bags‡
- > Advanced supplemental front-seat air bags‡
- > Trailer Sway Control®
- > Six-speaker audio system
- > Overhead console with map lamps, storage bin, HomeLink® Universal Transceiver controls, and sunroof controls (if equipped)

For a full list of optional features, explore the enclosed Buyer's Guide at the back of this catalog, or visit jeep.com.

* Based on Ward's segmentation, latest available competitive information, an EPA estimated 17 city/23 hwy mpg, and a 24.6-gallon fuel tank.



LIMITED

Limited adds just the right amount of finery to add that much more to every excursion. It gains respect with its unsurpassed horsepower and best-in-class* driving range — 550 miles* between fill-ups. Limited 4WD gives you unsurpassed capability due to the prowess of the available Quadra-Trac II® 4WD and the powerful available Selec-Terrain® vehicle management system.

STANDARD

- > Pentastar® 3.6L V6 engine
- > Quadra-Trac II active full-time 4WD system (4x4 models only)
- > Selec-Terrain Vehicle Management System (4x4 models only)
- > CommandView® dual pane panoramic sunroof
- > Electronic Stability Control (ESC)®
- > Remote start, remote key fobs
- > Rain-sensitive wiper system
- > Auto High Beam Headlamp Control
- > Heated first- and second-row leather-trimmed seats

> Uconnect® 430N CD/DVD/MP3/HDD

- > Uconnect Phone
- > Alpine® Premium Audio System
- > Infrared Dual Zone Climate Control
- > ParkSense® Rear Park Assist®
- > ParkView® Rear Back-Up Camera®
- > 18-inch polished cast aluminum wheels

For a full list of optional features, explore the enclosed Buyer's Guide at the back of this catalog, or visit jeep.com.





Grand Cherokee Overland® arrives with everything top-shelf right in place, earning nods as the Most Luxurious Vehicle in its class.¹ Go the extra mile by adding desirable options, and it will only enhance Overland's authentic capability and enviable luxury.

STANDARD

- > Pentastar® 3.6L V6 engine
- > Quadra-Trac II® Active Full-time 4WD System (4x4 models only)
- > Quadra-Lift® Air Suspension System and Selec-Terrain® Vehicle Management System (4x4 models only)
- > CommandView® dual pane panoramic sunroof
- > Remote start, remote key fobs, power liftgate, rain-sensitive wiper system
- > Auto High Beam Headlamp Control
- > Olive Ash Burl real wood steering wheel
- > Leather-wrapped and stitched instrument panel and armrests
- > Tinted glass, fog lamps, rear liftgate flipper glass
- > Heated first- and second-row leather-trimmed seats, ventilated front seats, Infrared Dual Zone Climate Control
- > Uconnect® 730N CD/DVD/MP3/HDD/NAV
- > Alpine® Premium Audio System
- > Leather-wrapped heated steering wheel with audio, speed, EVIC, Voice Command and Adaptive Cruise Control² (if equipped) controls
- > ParkSense® Rear Park Assist System³ and ParkView® Rear Back-Up Camera⁴
- > 20-inch Satin Carbon wheels

For a full list of optional features, explore the enclosed Buyer's Guide at the back of this catalog, or visit jeep.com.



Grandeur is expressed in every detail of Overland Summit.⁵ Within and out, it's filled with surprising luxuries and advanced capabilities, helping you Go Anywhere, Do Anything.⁶ The Grand Cherokee Overland Summit experience rises above the best of the best.

STANDARD

- > Pentastar® 3.6L V6 engine
- > Quadra-Trac II® Active Full-time 4WD system (4x4 models only)
- > Quadra-Lift® Air Suspension System and Selec-Terrain® Vehicle Management System (4x4 models only)
- > Chrome grille, fog lamp bezels, and tow hooks
- > CommandView® dual pane panoramic sunroof
- > Remote start, remote key fobs, power liftgate, rain-sensitive wiper system
- > Auto High Beam Headlamp Control
- > Black Olive Ash Burl real wood trim
- > Tinted glass, fog lamps, rear liftgate flipper glass, power folding mirrors
- > Heated first- and second-row leather-trimmed seats, ventilated front seats, Infrared Dual Zone Climate Control
- > Uconnect® 730N CD/DVD/MP3/HDD/NAV
- > Alpine® Premium Audio System
- > Leather-wrapped heated steering wheel with audio, speed, Adaptive Cruise Control,² EVIC, and Voice Command (if equipped) controls
- > Front Park Assist, ParkSense® Rear Park Assist System,³ and ParkView® Rear Back-Up Camera⁴
- > 20-inch bright polished aluminum wheels
- > Headlamp washers

For a full list of optional features, explore the enclosed Buyer's Guide at the back of this catalog, or visit jeep.com.





Trailhawk presents a very distinct profile, paired with authentic Trail Rated® capability, taken to a higher level with the addition of special rock rails and off-road tires. This predator instinctively knows how to handle the most extreme terrain, while still delivering all of the upscale comforts that only a Jeep® Grand Cherokee can deliver.

STANDARD

- > Pentastar® 3.6L V6 engine
- > 5-speed automatic transmission with Electronic Range Select
- > Off-Road Adventure II Package, including:
 - Quadra-Trac II® active full-time 4WD system
 - Selec-Terrain® with Hill Descent Control
 - Quadra-Lift® air suspension system
 - Skid plates
 - Full-size spare tire
- > Red tow hooks
- > Black and Red hood decal
- > Mineral Gray grille and rear light bar
- > Electronic Stability Control (ESC)®
- > Tinted glass
- > Uconnect® 430 AM/FM/CD
- > Leather-trimmed seats with suede inserts and Red accent stitching
- > Embroidered Red Trailhawk logo on front seats
- > Leather-wrapped steering wheel with audio, speed, Adaptive Cruise Control,¹ EVIC, and Voice Command (if equipped) controls
- > Mopar® slush mats
- > 18-inch Mineral Gray aluminum wheels with Goodyear® Silent Armor off-road tires
- > Unique rock rails
- > Unique Trailhawk badging and Red Trail Rated Badge

For a full list of optional features, explore the enclosed Buyer's Guide at the back of this catalog, or visit jeep.com.



From its aggressive stance to its vast reserve of race-inspired components, Grand Cherokee SRT® defines high performance and extreme automotive technology. Under its vented hood lives an awe-inspiring 470-hp powertrain that feeds an active 4WD system with adaptive damping. The result: a hair-raising top speed of 160 mph.

STANDARD

- > 6.4L V8 HEMI® engine with Fuel Saver Technology
- > Quadra-Trac® Active On-Demand 4WD
- > Selec-Track® adaptive damping system with Track, Sport, Auto, Snow, and Tow modes
- > 5-speed automatic transmission with paddle shifters and AutoStick
- > Electronic Limited-Slip Rear Differential
- > SRT performance brakes with Red 6-piston front/4-piston rear Brembo® calipers
- > SRT performance-tuned, fully hydraulic steering
- > Leather-wrapped upper door trim, instrument panel, and center armrest
- > Dual heat extractors on hood
- > Uconnect® 730N CD/DVD/MP3/HDD/NAV
- > SRT heated flat-bottomed steering wheel with paddle shifters
- > Remote start, remote key fobs, power liftgate, rain-sensitive wiper system
- > Auto High Beam Headlamp Control
- > Eight-way power driver and passenger seats
- > Heated and ventilated front seats, heated second-row seats
- > ParkView® Rear Back-Up Camera,¹⁰ ParkSense® Rear Park Assist,¹⁰ Forward Collision Warning,¹² Adaptive Cruise Control,⁴ Blind Spot Monitoring,¹⁴ Rear Cross-Path Detection⁹

For a full list of optional features, explore the enclosed Buyer's Guide at the back of this catalog, or visit driveSRT.com.



driveSRT.com



AUTHENTIC JEEP ACCESSORIES

Choose Mopar® for quality parts and accessories made to custom fit your Grand Cherokee. Mile after mile, you'll keep going strong with our expert service, genuine parts, Express Lane Service, and online Owner Connect Web site (register at owners.jeep.com). See your Jeep dealer for the latest parts and accessories. You can learn more about the world of Mopar and all it has to offer at mopar.com.



EXPRESS YOUR TRUE NATURE

Uncover an extensive line of fun that's been developed exclusively for the Jeep, brand enthusiast. From authentic wearables to unique gifts, all items are as rugged and durable as your Jeep vehicle. There's more to life when you can express what really moves you. Learn all about it at jeep.com/gear.

Jeep Gear



THIS STUNNING
ADVENTURE
NEVER ENDS



Jeep[®]

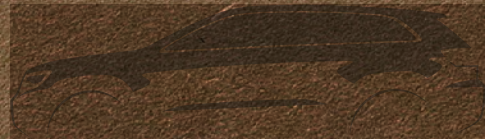

THE NEW 2014 GRAND CHEROKEE

AN ELEGANT MASTER OF ROAD AND TRAIL ALIKE

Incredibly smooth, undeniably controlled. This Grand Cherokee addresses all routes with the perfect manners born of a purebred. It is crafted to masterfully perform with style and grace, with a new 8-speed transmission that glides through each gear. A hushed, cushioned ride elevates every drive, in turn exceeding every expectation. A new and exquisite gathering of all the best has arrived, making the 2014 Grand Cherokee very, very grand, indeed.

AVAILABLE AT YOUR REQUEST

LUXURY — NATURA PLUS LEATHER TRIM / OPEN-PORE WOOD / SUEDE-LIKE PREMIUM HEADLINER

EFFICIENCY — 30 MPG* 3.0L ECODIESEL V6 ENGINE / 8-SPEED AUTOMATIC TRANSMISSION (STD.)

INNOVATION — 8.4-INCH TOUCH-SCREEN RADIO / 7-INCH CONFIGURABLE MULTI-VIEW DISPLAY

PROWESS — SELEC-TERRAIN® TRACTION SYSTEM / QUADRA-LIFT® AIR SUSPENSION

CONFIDENCE — OVER 60 STANDARD AND AVAILABLE SAFETY AND SECURITY FEATURES

*Chrysler estimated 30 highway mpg. 3.0L Turbo EcoDiesel engine and 8-speed transmission. Final EPA mileage not available at time of publication. Use for comparison purposes only.





THE BEST OF WHAT WE'RE MADE OF

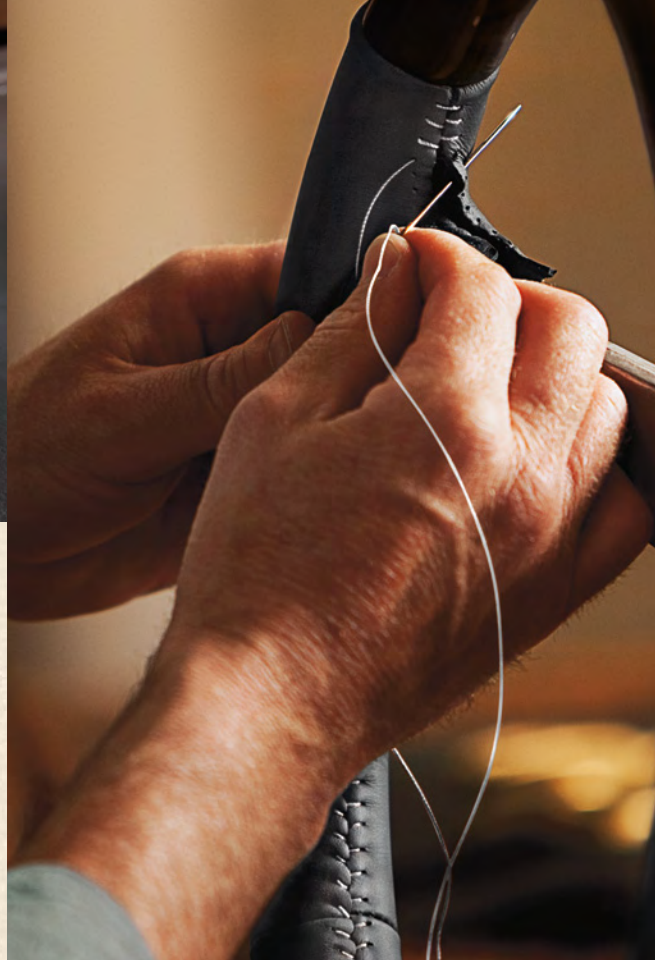
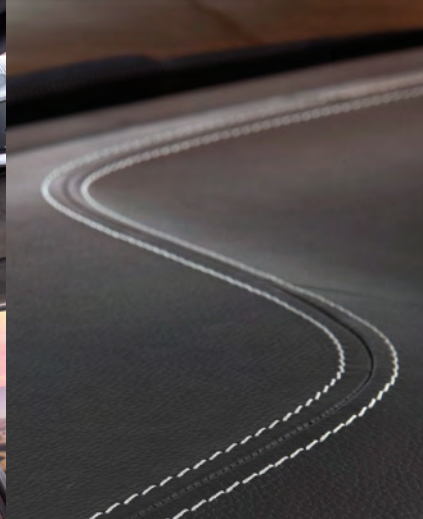

EVERY STITCH A MASTERSTROKE

Enhancements to the new 2014 Jeep® Grand Cherokee purposefully raise the bar. The stunning new cabin design begins with plush seating that can be trimmed with the most premium of leather in designer color palettes, brushed copper or silver accents, open-pore wood trim, and suede-like premium headliner. A very long list of premium standard features and available options pamper, impress, and keep you informed and connected like never before. This pinnacle of craftsmanship was created to better the best and make your daily routine anything but familiar.





Jeep

DIESEL



30 HWY MPG FUEL ECONOMY^{*+}

730-MILE DRIVING RANGE^{*+}

420 LB-FT OF TORQUE⁺

7,400 LB MAXIMUM TOWING^{**+}

* Chrysler estimated 30 highway mpg, 3.0L Turbo EcoDiesel engine and 8-speed transmission. Final EPA mileage not available at time of publication. Use for comparison purposes only.

+ Available with 3.0L EcoDiesel V6 engine.

** When properly equipped.

- > IMPROVED STANDARD 3.6L V6 ENGINE BOASTS 25 HIGHWAY MPG*
- > NEW 8-SPEED AUTOMATIC TRANSMISSION GLIDES THROUGH GEARS
- > NEW ECO MODE ADJUSTS SYSTEMS TO OPTIMIZE EFFICIENCY
- > NEW STEERING WHEEL-MOUNTED PADDLE SHIFTERS OFFER MANUAL SHIFT CONTROL



EFFICIENT, CLEAN, AND POWERFUL

Grand Cherokee's available, new 3.0L EcoDiesel V6 engine delivers exceptional economies and reduced CO₂ emissions. Commanding 240 hp and 420 lb-ft of torque, the EcoDiesel V6 engine provides a surge of towing strength that can haul up to 7,400 lb when properly equipped. The new standard 8-speed automatic transmission aids fuel efficiency across all powertrains, including the hearty 3.6L V6 and beefy 5.7L V8 engines. It also boasts quicker acceleration, smoother shifting, and a lower crawl ratio when equipped with a two-speed transfer case, enhancing Grand Cherokee's already legendary off-road prowess.

* Chrysler estimated 25 highway mpg. 3.6L V6 engine and 8-speed transmission. Final EPA mileage not available at time of publication. Use for comparison purposes only.



ENGAGES THE SENSES, WITH COMMON SENSE

A wealth of vehicle information, entertainment, and communication options are literally at your fingertips, all available hands-free. Grand Cherokee's new 7-inch Multi-View Display is fully customizable, allowing you to scroll through information and graphics from dozens of menu options. Screens for an available DVD/Blu-ray™ entertainment system¹ are mounted on both seatbacks, giving rear-seat passengers the option to enjoy movies or video games. The available 825-watt, 19-speaker high-performance Harman Kardon® sound system delivers sound quality that rivals what you hear in your best concert seats.



INFORMATION THAT MOVES YOU

Uconnect® keeps you in touch and informed every mile along the way. You'll enjoy a range of information and entertainment services, including SiriusXM Satellite Radio,² Travel Link with weather information,² and Traffic.²

INTRODUCING UCONNECT® ACCESS

Access the power of the cloud. Take advantage of all that Uconnect Access has to offer. Turn your Jeep® Grand Cherokee into a WiFi hotspot,³ giving you on-demand connectivity whenever and wherever you need it. Send a text just using your voice, start and unlock your Jeep Grand Cherokee remotely, make an emergency 911 call without taking your eyes off the road, and more.*



* App services late availability.





- > CHOICE OF THREE JEEP 4x4 SYSTEMS
- > AVAILABLE SELEC-TERRAIN® TRACTION SYSTEM
- > AVAILABLE QUADRA-LIFT® AIR SUSPENSION
- > NEW AVAILABLE SELEC-SPEED™ CONTROL
- > AVAILABLE TRAIL RATED® CAPABILITY



EVERY FEATURE TAKES YOU TO NEW HEIGHTS

Unprecedented and premium, Grand Cherokee delivers legendary prowess with a choice of three advanced four-wheel-drive systems. Maintain traction on a variety of surfaces with the help of the available Selec-Terrain® Traction System, now with new Selec-Speed™ for heightened throttle management on steep inclines and declines. For ultimate control of vehicle height, the optional Quadra-Lift® air suspension raises Grand Cherokee up to 10.7 inches above ridges and rocks, helping you navigate the most challenging obstacles.

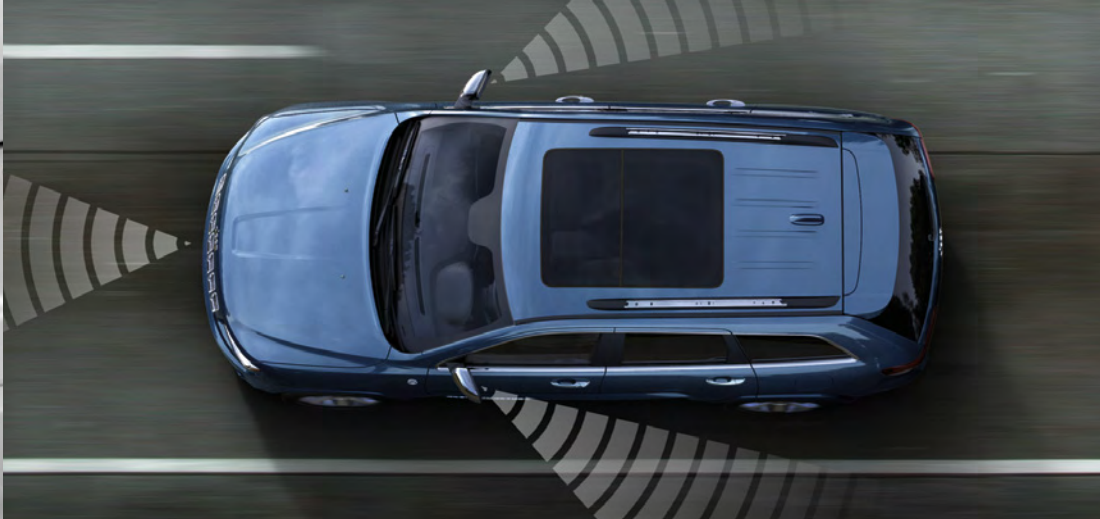

PEACE OF MIND DELIVERED 60 WAYS

Grand Cherokee surrounds you with more than 60 standard and available safety and security features. In an emergency, the available “911” call button immediately connects you with emergency personnel. The available Adaptive Cruise Control⁴ automatically adjusts cruising speed and maintains a preset distance between you and the car ahead. Available Adaptive HID Headlamps follow your cue as you turn the wheel, illuminating road curves for safer visibility. Blind Spot Monitoring,⁵ when equipped, uses radar sensors to help you monitor nearby vehicles.

OVER 60 STANDARD AND AVAILABLE SAFETY AND SECURITY FEATURES, INCLUDING:

- > Front Park Assist
- > Adaptive HID Headlamps
- > Adaptive Cruise Control⁴
- > Forward Collision Warning⁶ with Crash Mitigation
- > ParkView[®] Rear Back-Up Camera⁷ with New Dynamic Grid Lines
- > Driver Inflatable Knee Air Bag⁸
- > Electronic Stability Control⁹
- > Blind Spot Monitoring⁵ and Rear Cross-Path Detection⁷



CHOOSE YOUR PATH TO A REMARKABLE EXPERIENCE

It begins with the exceptionally elegant Laredo and climbs to the extraordinary height of indulgence in Summit.[®] The best of what we're made of makes up the new 2014 Jeep[®] Grand Cherokee lineup.



LAREDO

Keyless Enter'n Go; Quadra-Trac I[®] 4WD (4x4 models only); 3.6L V6 VVT engine; 8-speed automatic transmission; steering-wheel paddle shift control; 7-inch configurable Multi-View Display (EVIC); front and rear air bags;⁸ 17-inch painted aluminum wheels; projector fog lamps; daytime running headlamps; Uconnect[®] 5.0 radio (5-inch touch screen, SiriusXM Satellite Radio;² six speakers, and USB media hub); capless fuel fill door; LED taillamps; interior lighting for front footwell, and center console bin



LIMITED

INCLUDES LAREDO FEATURES, PLUS OR REPLACING: Quadra-Trac II[®] with Selec-Terrain[®] and Hill Descent Control (4x4); heated steering wheel; leather-trimmed seating; power eight-way passenger seat with four-way lumbar adjustment; heated front-row and second-row seating; 18-inch polished aluminum wheels; ParkSense[®] Rear Park Assist⁷ and ParkView[®] Rear Back-up Camera⁷ with dynamic grid lines; premium audio system with nine speakers, including subwoofer; unique Limited lower fascia; dual exhaust; bright door handles; power, heated, multifunctioning chrome mirrors; stakes in rear cargo area; door sill scuff pads with bright insert and Jeep[®] brand logo



INCLUDES LIMITED FEATURES, PLUS OR REPLACING: Quadra-Lift® Air Suspension System (4x4); Bi-Xenon HID headlamps with LED daytime running lamps; unique Overland® grille; power folding mirrors with puddle lamps; rain-sensing wipers; Nappa leather-trimmed ventilated front seats and leather-stitched instrument panel, door uppers, and center console armrest; real wood and leather-wrapped heated steering wheel; dual-pane sunroof; chrome tow hooks; power liftgate; power tilt/telescope steering wheel; 20-inch polished wheels with Mineral Gray pockets; Uconnect® navigation radio with 8.4-inch touch-screen display



INCLUDES OVERLAND® FEATURES, PLUS OR REPLACING: Quadra-Drive® II (4x4 V8); Natura Plus leather-trimmed seating; Harman Kardon® 825-watt premium sound system with 19 speakers, including 10-inch subwoofer; adaptive headlamps; headlamp washers; Front Park Assist; 20-inch full polished wheels with Satin clear coat; Blind Spot Monitoring;⁵ Forward Collision Warning;⁶ Adaptive Cruise Control⁴



6.4-Liter V8 SRT® HEMI® engine with Fuel Saver Technology; SRT leather-wrapped steering wheel with audio, EVIC, and cruise controls; Harman Kardon® 825-watt premium sound system; SRT Performance Pages; Uconnect® Voice Command with Bluetooth;® Keyless Enter'n Go; Quadra-Trac® Active, On-Demand 4-Wheel-Drive System; Selec-Track® Adaptive Damping Suspension with Track, Sport, Auto, Snow, and Tow Modes; electronic limited-slip rear differential; SRT Performance Brakes with 6-piston front/4-piston rear Brembo® calipers; Uconnect® navigation radio with 8.4-inch touch-screen display; dual heat extractors on hood; steering wheel-mounted paddle shifters; Adaptive Speed Control⁴ Visit driveSRT.com

A close-up, rear-quarter view of a red Jeep Grand Cherokee at night. The car's taillights are illuminated with a bright yellow glow. The "Jeep" logo is visible on the left side of the rear door, and a "JEEP" license plate is mounted below it. A "GRAND CHEROKEE" badge is located on the lower right side of the rear door. The car's body is highly reflective, showing highlights from the ambient light.

Jeep

JEEP

GRAND CHEROKEE

Explore more at [jeep.com](https://www.jeep.com)

GRAND CHEROKEE

(1) Late availability. (2) SiriusXM service requires a subscription, sold separately after 12-month trial included with vehicle purchase. If you decide to continue your SiriusXM service at the end of the trial subscription, the plan you choose will automatically renew and bill at the current rates until you call SiriusXM at 1-866-635-2349 to cancel. See our Customer Agreement for complete terms at siriusxm.com. Sirius satellite service is available only to those at least 18 and older in the 48 contiguous United States, D.C., and P.R. (with coverage limitations). SiriusXM Traffic available in select markets. See siriusxm.com/traffic for more information. Sirius, XM and all related marks and logos are trademarks of SiriusXM Radio Inc. (3) Sold separately. Subscription required. Uconnect WiFi feature is not intended for use by the driver while the vehicle is in motion. Always drive carefully. (4) ACC is a driver convenience system, not a substitute for active driver involvement. The driver must remain aware of traffic conditions and be prepared to use brakes to avoid collisions. (5) Always check visually for vehicles prior to changing lanes. (6) FCW system is solely an alert system for the front of the vehicle which does not take any actions to change vehicle dynamics to avoid a collision, not a substitute for active driver involvement. The driver must remain aware of traffic conditions and be prepared to use brakes to avoid collisions. (7) Always check entire surrounding visually before reversing. (8) The Advanced Front Air-bags in this vehicle are certified to the new U.S. federal regulations for advanced air bags. Children 12 years old and younger should always ride buckled up in a rear seat. Infants in rear-facing child restraints should never ride in the front seat of a vehicle with a passenger front air bag. All occupants should always wear their lap and shoulder belts properly. (9) No system, no matter how sophisticated, can repeal the laws of physics or overcome careless driving actions. Performance is limited by available traction, which snow, ice, and other conditions can affect. When the ESC warning lamp flashes, the driver needs to use less throttle and adapt speed and driving behavior to prevailing road conditions. Always drive carefully, consistent with conditions. Always wear your seat belt.

This brochure is a publication of Chrysler Group LLC. All product illustrations and specifications are based upon current information at the time of publication approval. Chrysler Group LLC reserves the right to make changes from time to time, without notice or obligation, in prices, specifications, colors, materials, and to change or discontinue models, which are considered necessary to the purpose of product improvement or for reasons of design and/or marketing. Jeep, the Jeep grille, Grand Cherokee, HEMI, Laredo, Overland, Overland Summit, ParkSense, ParkView, Quadra-Drive, Quadra-Lift, Quadra-Trac I, Quadra-Trac II, Selec-Terrain, Selec-Track, SRT, Trail Rated, and Uconnect are registered trademarks and Selec-Speed is a trademark of Chrysler Group LLC. Bluetooth is a registered trademark of Bluetooth SIG, Inc. Blu-ray Disc is a registered trademark of Blu-ray Disc Association. Brembo is a registered trademark of Freni Brembo S.p.A. Goodyear is a registered trademark of The Goodyear Tire & Rubber Company. Harman Kardon logo is a registered trademark of Harman International Industries, Inc. Sirius, XM, and all related marks and logos are trademarks of SiriusXM Radio Inc. © 2013 Chrysler Group LLC. All rights reserved.



2014 GRAND CHEROKEE

Jeep

TODAY IS THE DAY YOU COMMIT TO GREATNESS.
NOW IS THE TIME TO GIVE PURPOSE TO YOUR
DRIVING PASSION. EVERY MINUTE. EVERY SECOND.
NOTHING IS GREATER THAN WHAT LIES AHEAD.
THE 2014 JEEP® GRAND CHEROKEE DEFINES
ACHIEVEMENT. HERE, YOU CAN ACHIEVE IT ALL.



SUMMIT SHOWN IN CASHMERE PEARL

GRAND CHEROKEE SUMMIT.
WITH THE BEST, YOU
BECOME THE BEST.



BEAUTIFULLY RESILIENT



HARSH WEATHER IS WORRY-FREE WITH GRAND CHEROKEE'S EXPANSIVE MENU OF CAPABILITIES. DESIGNED TO WORK TOGETHER IN TRUE HARMONY, THEY USHER YOU OVER AND THROUGH MOST ANY CHALLENGE MOTHER NATURE LAYS BEFORE YOU. EXPERIENCE LEGENDARY JEEP® BRAND DNA IN ITS MOST ELEGANT OF FORMS.

SUMMIT SHOWN IN BRILLIANT BLACK CRYSTAL PEARL

AXXA

AUTHENTIC CAPABILITY

Confidence to Go Anywhere, Do Anything® is born and bred in every Jeep® brand transfer case. Choose from three authentic four-wheel-drive systems: Quadra-Trac I®, Quadra-Trac II®, and Quadra-Drive® II with an Electronic Limited-Slip Differential (ELSD). Each is engineered to help safely usher you through severe all-weather challenges.

ELECTRONIC STABILITY CONTROL®

Vehicle-wide sensors help keep you moving forward securely, instantly providing aid in stressed and extreme situations.

INDEPENDENT SUSPENSION

Independent front and rear suspension systems with isolated cradles help stabilize travel over challenging terrain. Standard.

QUADRA-LIFT® AIR SUSPENSION SYSTEM

Gain ultimate control of your system. Raise up to a best-in-class ground clearance¹ of 11.3 inches above rocks and snowbanks. Lower it 1.6 inches for easier entry, exit, and loading. Available.

SELEC-TERRAIN® TRACTION SYSTEM

Maintain a strong grip on your driving surface. Select from five different "modes," and engage the new Selec-Speed™ for incredible speed control on steep inclines and declines. Coordinates 12 different vehicle management systems. Available.

PREMIUM EXTERIOR LIGHTING

Come rain or snow, foggy nights or sunny mornings, Daytime Running Lamps are well-known to raise the visibility of your vehicle. Add the optional Signature LED lights and the profile of your Grand Cherokee will raise to very impressive heights. Available Adaptive HID Headlamps follow your cue as you turn the wheel, illuminating road curves for safer visibility. Headlamp washers are available to help maintain visibility during slushy, muddy conditions. A high-pressure spray of washer fluid helps keep your headlamps safely crystal-clear.



EVERY TOUCH IS SUMPTUOUSLY SOFT. EVERY STITCH A MASTERSTROKE.

PASSION FLOWS WITHIN



SUMMIT INTERIOR DASH STITCHING DETAIL SHOWN IN GRAND CANYON-JEEP BROWN



SUMMIT LEATHER-TRIMMED SEAT SHOWN IN GRAND CANYON-JEEP BROWN

BREATHTAKINGLY GRACIOUS

SUMMIT LEATHER-TRIMMED INTERIOR SHOWN IN GRAND CANYON-JEEP, BROWN

THE MOST LUXURIOUS SUV IN ITS CLASS*

Grand Cherokee Summit achieves the most premium status by delivering an experience that is truly first-class. No other similar-sized SUV presents a more extensive list of inviting features. Summit owns this benchmark of exclusivity.

INSPIRED DESIGNER PALETTE

Summit's available Jeep® Brown interior is inspired by the warm tones that grace the majestic walls of the Grand Canyon. Copper-colored bezels and accent stitching continue the homage to this world wonder.

ELEGANT TOUCH POINTS

Premium Natura-Plus leather is featured on Summit's leather-trimmed seats, console, lower instrument panel, and door panels. Real open-pore wood in Summit Brown adorns the instrument panel and door trim. A soft, suede-like headliner adds to the rich appeal of Summit's unique interior design.

SEATING IN FIRST CLASS

All first- and second-row seats are heated for comfort in every climate, and front seats are ventilated and power-adjustable eight ways, with four-way lumbar adjustment.

HIGH TECH MEETS HIGH EXPECTATIONS

 Amazing and brilliant, the available Uconnect® 8.4-inch touch screen treats you to a wealth of intuitive features like voice recognition, navigation, climate control, and so much more. And the customizable 7-inch Multi-View Display offers a quick and easy glimpse at a myriad of vehicle systems and driving information.

LUXURY FOR AUDIOPHILES

For those who appreciate world-class sound design, Harman Kardon® sound engineers have developed an available state-of-the-art system that sends 825 watts of power surging into 19 carefully placed speakers.



THE AUTHENTICITY AND HONESTY OF REAL WOOD EMBODY TIMELESS BEAUTY AND LASTING STRENGTH.



REAL WOOD

PADDLE SHIFTERS

CRUISE CONTROL

AVAILABLE ADAPTIVE CRUISE CONTROL¹²

LEATHER TRIM

GRAND CANYON

Crafted after the shades of warm brown and amber found within the majestic cliffs of the Grand Canyon. Beautiful Copper-colored bezels and accent stitching enhance the overall rich appeal. Available.

MT. VESUVIUS

This unique pairing of Indigo Blue and Jeep Brown mirrors the evening hues of Italy's Mt. Vesuvius. Open-pore Zebrano wood trim, Silver-colored bezels, and accent stitching finish the vision. Available.

NEW ZEALAND



A diverse landscape of glaciers, mountains, and rugged coastline provided the inspiration for a timeless contrast of Black and Light Frost Beige. Available.

A WORLD-INSPIRED PALETTE

OUR DESIGNERS LOOKED TO THE NATURAL HUES FOUND IN SOME OF THE WORLD'S MOST ICONIC LANDSCAPES. THERE, THEY FOUND INSPIRATION THAT TRANSLATES INTO STUNNING INTERIORS CRAFTED WITH LUSH MATERIALS AND THE MOST THOUGHTFUL OF DETAILS.

MOROCCO

Inspired by the magical shadows of the Marrakech market and the sublime softness of the Saharan desert, this classic Black interior shows off Grand Cherokee in luxuriously deep tones. Available.

NEPAL

Travelers the world over are drawn to the surreal beauty and presence of Himalayan mountains, where the natural combination of Jeep Brown and Light Frost Beige earthtones was derived. Available.

FINGERTIP CONTROLS ON YOUR STEERING WHEEL CAN INSTANTLY SCROLL YOU THROUGH A RICH SELECTION OF VEHICLE DATA. IT'S DISPLAYED WITHIN YOUR INSTRUMENT PANEL ON A 7-INCH FULL-COLOR THIN FILM TRANSISTOR (TFT) SCREEN. IF KNOWLEDGE IS POWER, THIS VAST ARRAY OF WISDOM MAKES YOU VERY STRONG, INDEED.

NAVIGATION

Partnering with your available Nav Radio, the Multi-View Display can show turn-by-turn directions, as well as additional details that help you navigate your way.

VEHICLE ALERTS

You'll receive visual notification here for safety systems, such as available Forward Collision Warning¹ and Advanced Brake Assist. Set the distance for the available Adaptive Cruise Control².

PERFORMANCE

Get real-time fuel economy data. See how many miles you can travel before you need to refuel. When the available Adaptive Cruise Control (ACC) senses a vehicle ahead, it will apply limited braking or acceleration automatically to maintain a preset following distance, while matching the speed of the vehicle ahead.

CAPABILITY

See the current settings for your available Quadra-Lift[®] Air Suspension System and steering-wheel position. You can also see how your available Selec-Terrain[®] system is functioning via perspective visuals.

VEHICLE DYNAMICS

Are your tires properly inflated? You'll be notified if the pressure is low on any tire. Driving off-road? See a graphic depiction of how your wheels are articulating.

CONFIGURABLE 7-INCH MULTI-VIEW DISPLAY



MULTI-VIEW DATA CONTROLS

HANDS-FREE VOICE COMMAND CONTROL FOR BLUETOOTH[®] ENABLED PHONE, AUDIO, CLIMATE, NAVIGATION, AND MORE

GRASP THE FINER THINGS IN LIFE.

Leather trim on a newly designed and extraordinarily functional steering wheel. The comforting, available function of approach lamps on exterior mirrors. Keyless Enter 'n Go with push-button start. Delivery of informative vehicle functions with a simple touch of a button. Standard steering-wheel paddle shifters hand over gearshift control to your fingertips. This is how life on the road becomes a highly anticipated event.



REAL WOOD

PADDLE SHIFTERS

CRUISE CONTROL

AVAILABLE ADAPTIVE CRUISE CONTROL²

LEATHER TRIM

A WORLD-INSPIRED PALETTE

GRAND CANYON

Crafted after the shades of warm brown and amber found within the majestic cliffs of the Grand Canyon. Beautiful Copper-colored bezels and accent stitching enhance the overall rich appeal. Available.

NEW ZEALAND

A diverse landscape of glaciers, mountains, and rugged coastline provided the inspiration for a timeless contrast of Black and Light Frost Beige. Available.

MOROCCO

Inspired by the magical shadows of the Marrakech market and the sublime softness of the Saharan desert, this Classic Black interior shows off Grand Cherokee in luxuriously deep tones. Available.

MT. VESUVIUS

This unique pairing of Indigo Blue and Jeep[®] Brown mirrors the evening hues of Italy's Mt. Vesuvius. Open-pore Zebrano wood trim, Silver-colored bezels, and accent stitching finish the vision. Available.

NEPAL

Travelers the world over are drawn to the surreal beauty and presence of Himalayan mountains, where the natural combination of Jeep Brown and Light Frost Beige earthtones was derived. Available.

OUR DESIGNERS LOOKED TO THE NATURAL HUES FOUND IN SOME OF THE WORLD'S MOST ICONIC LANDSCAPES. THERE, THEY FOUND INSPIRATION THAT TRANSLATES INTO STUNNING INTERIORS CRAFTED WITH LUSH MATERIALS AND THE MOST THOUGHTFUL OF DETAILS.

A silver Jeep Grand Cherokee SUV is parked on a dirt path in a dense forest of tall, thick redwood trees. The scene is illuminated by soft, natural light filtering through the canopy, creating a serene and majestic atmosphere. The car is positioned on the left side of the frame, facing towards the left. The trees are massive, with deeply textured bark and lush green foliage. The ground is covered in a layer of brown mulch and green ferns.

WITH GRAND CHEROKEE'S
BEST-IN-CLASS FUEL ECONOMY,⁸
YOUR QUEST FOR EXCELLENCE
HAS BEEN REALIZED.

OVERLAND[®] SHOWN IN GRANITE CRYSTAL PEARL

INTRODUCING THE



3.0L V6 ENGINE

BEST-IN-CLASS:

30 MPG

FUEL ECONOMY⁸

730-MILE

DRIVING RANGE¹

420 LB-FT

OF TORQUE⁵

7,400-LB

MAXIMUM TOWING^{2*}

*WHEN PROPERLY EQUIPPED.

SUMMIT SHOWN IN AUBURN PEARL



EVERY GRAND CHEROKEE POWERPLANT GAINS EFFICIENCIES.

WHEN YOU TELL THEM YOUR GRAND CHEROKEE TRAVELED 730 HIGHWAY MILES WITHOUT REFUELING ONCE, YOU'LL PROBABLY HAVE TO TELL THEM TWICE.

Thirty miles per gallon? True story. Grand Cherokee's new, available 3.0L EcoDiesel V6 engine delivers best-in-class economies⁸ that treat your fuel budget with respect, while its reduced CO₂ emissions display reverence for the environment. Proudly, the EcoDiesel meets and even exceeds the low emissions requirements in all 50 states. Best-in-class fuel economy⁸ arrives with an estimated 22 city/30 hwy mpg,³ and a driving range of more than 730 highway miles per tank¹. That's because, compared to gasoline, a gallon of diesel fuel converts to a greater amount of useable energy. So you can leave Detroit, MI, with a full tank and arrive in New York City without ever stopping to refuel. And with its command of 240 hp and a hefty 420 lb-ft of torque, the EcoDiesel provides a surge of towing strength that can haul up to 7,400 lb when properly equipped. Stats so good, they're worth repeating every chance you get.

3.6L V6 PENTASTAR[®] ENGINE

Three times named one of *Ward's* 10 Best Engines, the flex-fuel Pentastar now boasts an increase in fuel economy. Paired with the new 8-speed automatic transmission, it achieves 290 hp, an EPA estimated 17 city/25 highway mpg, and cranks out enough power to tow up to 6,200 lb when properly equipped — a 24 percent increase in pulling power. Standard.

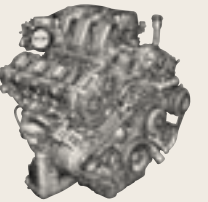

5.7L V8 ENGINE

This available workhorse churns out best-in-class maximum towing power² of up to 7,400 lb when properly equipped. It gives out 360 hp and a brawny 390 lb-ft of torque, while also employing additional fuel-saving efficiencies thanks to Variable Valve Timing (VVT), Fuel Saver Technology, and the new 8-speed transmission. Available.

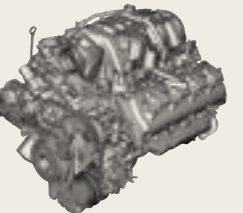

ECO MODE

This new, selectable feature constantly works to maximize your fuel economy by automatically modifying the shift schedule of the 8-speed transmission and torque converter and gently lowering your idle speed to gain precious mpg. The Multi-View Display in your instrument panel can inform you of just how efficiently Eco Mode is performing every mile along the way.



ALL-NEW 8-SPEED AUTOMATIC TRANSMISSION

It glides with a smooth and quick efficiency, consistently using energy to its best advantage. This is Grand Cherokee's new standard 8-speed automatic transmission. Its construction provides additional gears with no gain in weight, enhanced acceleration with reduced fuel consumption, and increased torque with added strength to pull. This Grand Cherokee drives to engage a new stratum of automotive connoisseurs: SUV motorists who desire a premium driving experience paired with an efficient performance. The system's precise design and shift schedule can implement a gear change in 200 milliseconds. This kind of fine-tuning can elevate ride quality to levels experienced in the most luxurious sedans. There's excitement as well, by engaging the steering-wheel-mounted paddle shifters when you want to customize your shift schedule. The best possible fuel economies can be attributed to a wide ratio spread that supports lower engine rpm driving in both city traffic and on the highway. When equipped with a two-speed transfer, crawl ratio is improved by 46 percent, enhancing Grand Cherokee's legendary prowess. Shift into the available Sport Mode and your shift schedule and engine power are both adjusted to hand over a sportier driving experience. It all adds up to a ride that delivers powerful strength without compromise.

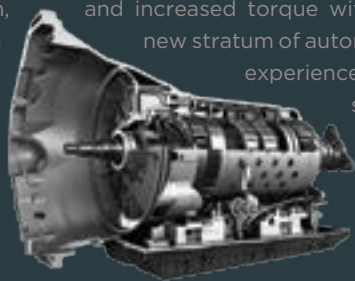

WHY STOP AT SIMPLY RAISING THE BAR? THIS IS HOW TO MOVE AHEAD WITH AN AIR-CUSHIONED, ADJUSTABLE RIDE HEIGHT THAT SMOOTHS ON-ROAD HANDLING, INCREASES FUEL EFFICIENCY, EASES ENTRY AND LOADING, AND LIFTS GRAND CHEROKEE TO BEST-IN-CLASS GROUND CLEARANCE³ ... ALL WITH FINGER-TOUCH CONTROL.



PARK



AERO



OFF-ROAD 1



OFF-ROAD 2



⊖ PARK // EASIER ENTRY, EXIT, AND LOADING

In Park Mode, this closed-type air suspension system gently lowers Grand Cherokee 1.6 inches below normal ride height to allow for a more graceful entrance and exit, as well as for loading cargo.



⊖ AERO // OPTIMAL FUEL EFFICIENCY

When traveling at cruising speeds, Quadra-Lift[®] automatically lowers the vehicle 0.6 inches below normal ride height to Aero Mode. This, in turn, improves aerodynamics and fuel efficiency.

QUADRA-LIFT[®] AIR SUSPENSION



+ OFF-ROAD 1 // HELPS CLEAR OBSTACLES

When you find yourself negotiating deep snow, mud, or two-track trails, switch Quadra-Lift to Off-Road 1 Mode for an added vehicle height of 1.3 inches, giving your capability a serious lift.

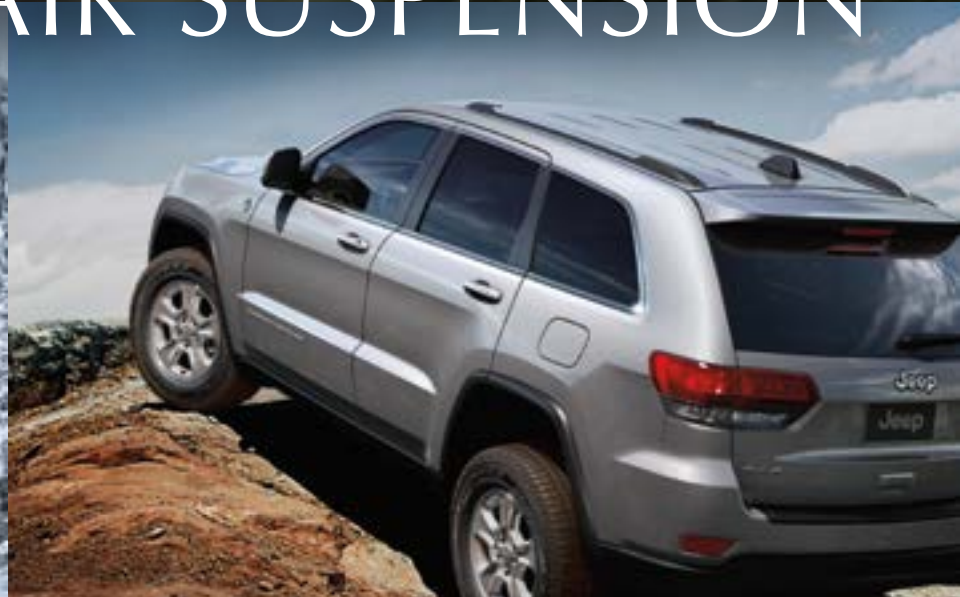

+ OFF-ROAD 2 // BEST-IN-CLASS CLEARANCE³

Quadra-Lift takes you to legendary heights with the push of a button. In Off-Road 2 Mode, you'll rise 2.6 inches above normal ride height — ideal for deep ruts, tall brush, and protruding rocks.

WHEN YOUR POTENTIAL IS ONLY
OUTWEIGHED BY YOUR CAPABILITY,
ANYTHING IS POSSIBLE.



LIMITED SHOWN IN BILLET SILVER METALLIC

SAND

Traction control operates with aggressive response to wheel spin. The suspension raises for optimal performance. Deeper wheel-slip antilock brake settings and off-road-tuned Electronic Stability Control (ESC)[®] are among the primary systems engaged.

MUD

Quadra-Lift[®] Air Suspension system raises to Off-Road 1 Mode, Traction Control operates with sensitive response to wheel spin, and torque is tuned for optimal performance.

ROCK

Raises the vehicle to the maximum ground clearance of 11.3 inches; the transfer case, differential, and throttle coordinate to provide low-speed control. ESC[®] is tuned appropriately for off-road conditions.

SNOW

Adjusts for ultimate performance over snow- and ice-covered roads by maximizing vehicle stability and minimizing oversteer. Major systems auto-engaged and managed in this Mode include antilock brakes and traction control.



SELEC-TERRAIN[®]

TRACTION MANAGEMENT



SELEC-TERRAIN[®] TRACTION SYSTEM

Five selectable settings give you ultimate driving confidence by coordinating 12 vehicle systems, including throttle control, transmission shifting, transfer case, traction control, and Electronic Stability Control.[®] Choose from Sand, Mud, Auto, Snow, and Rock. In Auto, Selec-Terrain does all the work, automatically adjusting vehicle dynamics to best suit the terrain.

SELEC-SPEED[™] CONTROL

Selec-Speed adds Hill Ascent Control to the familiar Hill Descent Control. Hill Ascent engages the throttle to help provide stable low-range control when going uphill, where Hill Descent uses engine and physical braking to aid in vehicle control when going downhill.

JEEP[®] 4x4 CONFIDENCE

Choose from three available 4WD systems:

- + **QUADRA-DRIVE[®] II** employs an Electronic Limited-Slip Differential that can transfer up to 100 percent of torque to the rear wheel(s) with traction to help you maintain forward movement.
- + **QUADRA-TRAC II[®]** offers all-speed traction control via a two-speed low transfer case that can quickly distribute power to the axle with the most traction.
- + **QUADRA-TRAC I[®]** is fully automatic, offering a continual balance of torque distribution; if slippage occurs, torque is transferred to the axle with the most traction. Available.

TRAIL RATED[®] CAPABILITY

Excel in extreme conditions like mud, sand, snow, and ice when your Grand Cherokee is equipped with an authentic Trail Rated 4WD system. Every Trail Rated badge indicates testing and mastery in five performance categories: Traction, Ground Clearance, Maneuverability, Articulation, and Water Fording.^{1*}





GRAND CHEROKEE OVERLAND.[®]
THE VIEW EXCEEDS
EXTRAORDINARY EXPECTATIONS.

TIMELESS GRANDEUR

Heritage runs deep within the DNA of Overland, beginning with its name, long associated with the revered Willys-Overland, a legendary vehicle that stands at the forefront of Jeep[®] brand history. Today, Overland carries the legendary torch of strength and honor, with astounding enhancements that take it to a brand-new level of comfort and luxury. A long list of standard features such as leather-stitched dashboard and dual-pane sunroof and available features like 4WD with standard Quadra-Lift[®] Air Suspension come together to distinguish the name of Overland once again.



INSPIRED DESIGNER PALETTE

Available for Overland,* this interior color scheme of Indigo Blue and Jeep, Brown is crafted from luxurious Nappa leather trim, open-pore Zebrano wood trim, and Silver-colored bezels. Bright accent stitching adds to the stunning impact.

DISTINCTIVE AND PLUSH

Overland arrives with a standard CommandView® dual-pane panoramic sunroof, and a vibrant 8.4-inch Uconnect® touch screen with voice operation for navigation, communication, voice text reply, and entertainment services. First- and second-row leather-trimmed heated seats are designed for the utmost in cushioned comfort and style. Even more, first-row seats are also ventilated. Unique contrast stitching adds glamour to the leather-trimmed dashboard. There's so much to experience with Overland's long list of premium features.

ALPINE® PREMIUM AUDIO

ALPINE Welcome to the Alpine Surround Sound System, standard in Grand Cherokee Overland and Limited. This premium audio system utilizes a high-powered, 12-channel, 506-watt amplifier powering nine speakers and a subwoofer, optimally placed throughout the cabin.



CLIMATE CONTROL VIA UCONNECT

Create a comfortable cabin using the HVAC controls on the available 8.4-inch touch-screen radio with voice commands. You can say "set driver temp to 72 degrees" to adjust dual-zone temperatures (when equipped), engage the defrost system, or turn on the heated and ventilated seats, all without ever taking your hands off the wheel.

A STUNNING DISPLAY OF DISTINCTION

MASTERFULLY SIMPLE.

WITH THE AWARD-WINNING AND INTUITIVE UCONNECT® SYSTEM, YOU'RE ALWAYS CONNECTED, INFORMED, ENTERTAINED, AND MORE PRODUCTIVE. YOU CAN ALSO VOICE YOUR CHOICE TO CONTROL NEARLY EVERY FEATURE HANDS-FREE WITH THE LATEST AVAILABLE VOICE RECOGNITION TECHNOLOGY. THIS IS HOW YOU ADVANCE YOUR WORLD IN A WORLD THAT'S VERY ADVANCED.

WIFI. All along the way, you can upload and download, post, and search. Uconnect® with available WiFi links compatible devices to the Web. Your office is as mobile as you are. Connect Web-enabled devices, and passengers can stay in play.

PHONE/TEXT. Plans can change en route. Safely spread the word with a hands-free phone call or use your voice to send out a text. Pair up to eight Bluetooth® enabled phones, and voice commands allow you to easily "call Judy" or "redial" as you negotiate midtown traffic.

NAVIGATION. Dinner reservations at the new place in town? Uconnect employs GPS navigation for audible turn-by-turn directions, and detailed 3-D maps help to assure you arrive on time. The NAV is integrated into your 7-inch Multi-View Display so you can see directions front and center. Use Voice Command and say the complete address, city, and state, and get directions quickly. Your first year of SiriusXM Traffic® service is included.

VOICE COMMAND. It simplifies driving by letting you keep your eyes on the road and your hands on the wheel. Use your voice to select AM/FM radio stations or SiriusXM Satellite Radio® channels, or make calls. Select navigation destinations, set cabin temps, or show fuel prices. This smart technology can understand commands in English, French, and Spanish.

ENTERTAINMENT. Tonight's soundtrack? It can change, Uconnect follows your lead. Listen to your favorite playlist, then flip to a news or comedy station, or get the latest sports scores. SiriusXM lets you tag, rewind, and play favorite songs or artists. You'll get 160 channels from the available SiriusXM Satellite Radio®, or connect your own device.

EMERGENCY HELP. Reach a local 9-1-1 operator immediately by pushing one dedicated 9-1-1 button. And a Roadside Assistance button puts you in touch with someone who can get you help. Both safety features are available with Uconnect.

UCONNECT ACCESS A NEW LEVEL OF INNOVATION

THIS NEW SUITE OF UCONNECT® FEATURES AND SERVICES REPRESENTS THE NEXT GENERATION OF IN-VEHICLE CONNECTIVITY. WITH THE SIMPLICITY OF VOICE COMMAND AND FINGERTIP CONTROL, YOU CAN NOW ACCESS ALL OF THESE BRILLIANT OFFERINGS:

9-1-1 CALL. In the event of an emergency, a button on your rearview mirror connects you with local authorities.

ROADSIDE ASSISTANCE CALL. Flat tire or need a tow? The Assist button on your rearview mirror connects you to Roadside Assistance, which automatically knows your vehicle and location. Additional fees may apply.

STOLEN VEHICLE ASSISTANCE. If your vehicle is ever stolen, Uconnect can provide its location to aid police recovery.

THEFT ALARM NOTIFICATION. Choose to receive a text or email alert anytime your vehicle's theft alarm is activated.

VOICE TEXTING.* Powerful, Cloud-based voice texting on compatible Bluetooth phones lets drivers hear a text or read and dictate an original message. Hands stay on the wheel, eyes stay on the road, and drivers stay safely connected.

WIFI HOTSPOT. Create a mobile, on-demand hotspot in and around your vehicle, so passengers can stay securely connected wirelessly on their personal devices.

INSTANT IN-VEHICLE ASSIST. Questions about a Uconnect feature, app, or your new Grand Cherokee? Press the Access button to connect with the right source for answers.

UCONNECT ACCESS APP. From virtually anywhere, use your computer or the custom smartphone app to remotely lock or unlock your vehicle, start the engine to warm up or cool down the interior, or sound the horn and flash the lights.

CONNECTED SEARCH. Conduct a real-time local search to find restaurants, coffee shops, and other businesses sorted by rating and location.



*Requires the vehicle to be registered for Uconnect Access, and use with a smartphone that has Bluetooth® Message Access Profile (MAP). iPhone® and some other smartphones do not currently support Bluetooth MAP.

WHAT A BEAUTIFUL WAY TO STAY CONNECTED. UCONNECT® PUTS YOU IN FULL CONTROL WITH AN AVAILABLE 8.4-INCH TOUCH SCREEN CONVENIENTLY POSITIONED FRONT AND CENTER. HERE, CONTROLS AND DATA ARE DISPLAYED IN CRYSTAL CLARITY. WELCOME TO COMMAND CENTRAL.



NAVIGATION WITH 3-D MAPPING. Use your voice to enter a complete address in one step. Uconnect® will provide mapping on its 8.4-inch touch screen, as well as audible turn-by-turn directions. You'll see full-color three-dimensional modeling of urban destinations to help identify landmarks and street junctions. This feature is available with the Uconnect 8.4AN radio.

HANDS-FREE PHONE. Uconnect easily connects with your compatible phone, and allows quick access to your stored contacts. With Voice Command, you can say who you want to call or text. A standard feature on all radios.

VARIETY ENTERTAINMENT. Connect your compatible media device, stream your music via Bluetooth® streaming audio or SD card, or listen to HD radio. And with SiriusXM Satellite Radio®, you can access 160 channels of news, sports, talk, and premium entertainment. Your first year of service is included.



SIRIUSXM ALL ACCESS¹⁵ programming goes with you wherever you travel, via your vehicle, computer, smartphone, or tablet. In your vehicle, get every channel available on your radio, including all of the premium programming. Plus, listen wherever you go on your portable devices with a SiriusXM Internet Radio subscription included with your trial. Options in all the places life takes you.



SIRIUSXM TRAVEL LINK¹⁵ Get the latest national and local weather reports and ski slope conditions while you're on the road. Find the best fuel prices at nearby gas stations. Check in-game scores of your favorite team or see how they fared in their last matchup. See what's playing and when at the nearest movie theatre. Your first year of SiriusXM Travel Link® service is included.



VOICE TEXTING. Powerful, Cloud-based voice recognition allows you to dictate free-form text messages, and send them from your Bluetooth® enabled phone without taking your hands off the wheel or focus from the road. Available on all radios.

APPS. Uconnect® Access turns your vehicle into a WiFi hotspot via the power of the Cloud. This suite of new services includes 9-1-1 Call, Roadside Assistance, Stolen Vehicle Assistance, Theft Alarm Notification, Local Connected Search, and a smartphone app that enables you to lock and unlock your doors and start your car. Uconnect Access brings the next level of mobile in-vehicle technology to your fingertips. Available on all radios.

AVAILABILITY OF APPLICATIONS SUBJECT TO CHANGE.



COMMANDVIEW[®]
DUAL-PANE SUNROOF



A NEW PERSPECTIVE
ON LIVING WELL

COMMANDVIEW[®] PANORAMIC SUNROOF

This view from the top is revealing. There's more to be seen when you look up and out via Grand Cherokee's available full-power sunroof with a power sunshade in front, a fixed-glass window in the rear, and available suede-like headliner above. One look at this dual-paned sliding-glass ceiling and you'll definitely enjoy seeing what comes naturally into view.

STYLE AND GRACE

A new level of opulence is expressed in the exterior details of Grand Cherokee Limited. From a re-envisioned body design to thoughtful specialties that only a Jeep® brand vehicle can bear, Limited's bright door handles, dual Chrome exhaust tips, and 18-inch polished aluminum wheels add special sparkle. There's a new capless fuel filler with an electronically locking fuel door that simplifies your stop at the pump, and a new standard power liftgate for easier access. A signature design for the new projection fog lamps, available LED daytime running lamps, and rear taillamps allow Grand Cherokee to see and be seen within a special spotlight.

POWER LIFTGATE

Keep hold of packages and open the liftgate without any fancy footwork. The available power liftgate adds graceful accessibility to Grand Cherokee's rear cargo area. Keyless Enter 'n Go is hands-free via the key fob, so you can avoid fumbling last-minute to unlock the gate.

GRAND CHEROKEE LIMITED.
CRAFTSMANSHIP SHINES FROM
EVERY SCULPTED CORNER.





**BLU-RAY™ PLAYER WITH
SEATBACK-MOUNTED VIDEO SYSTEM**

Two available 9-inch high-resolution screens are integrated into the seatback to entertain rear-seat passengers. The system can play standard DVDs as well as Blu-ray discs, and includes independent HDMI and RCA inputs for each screen.

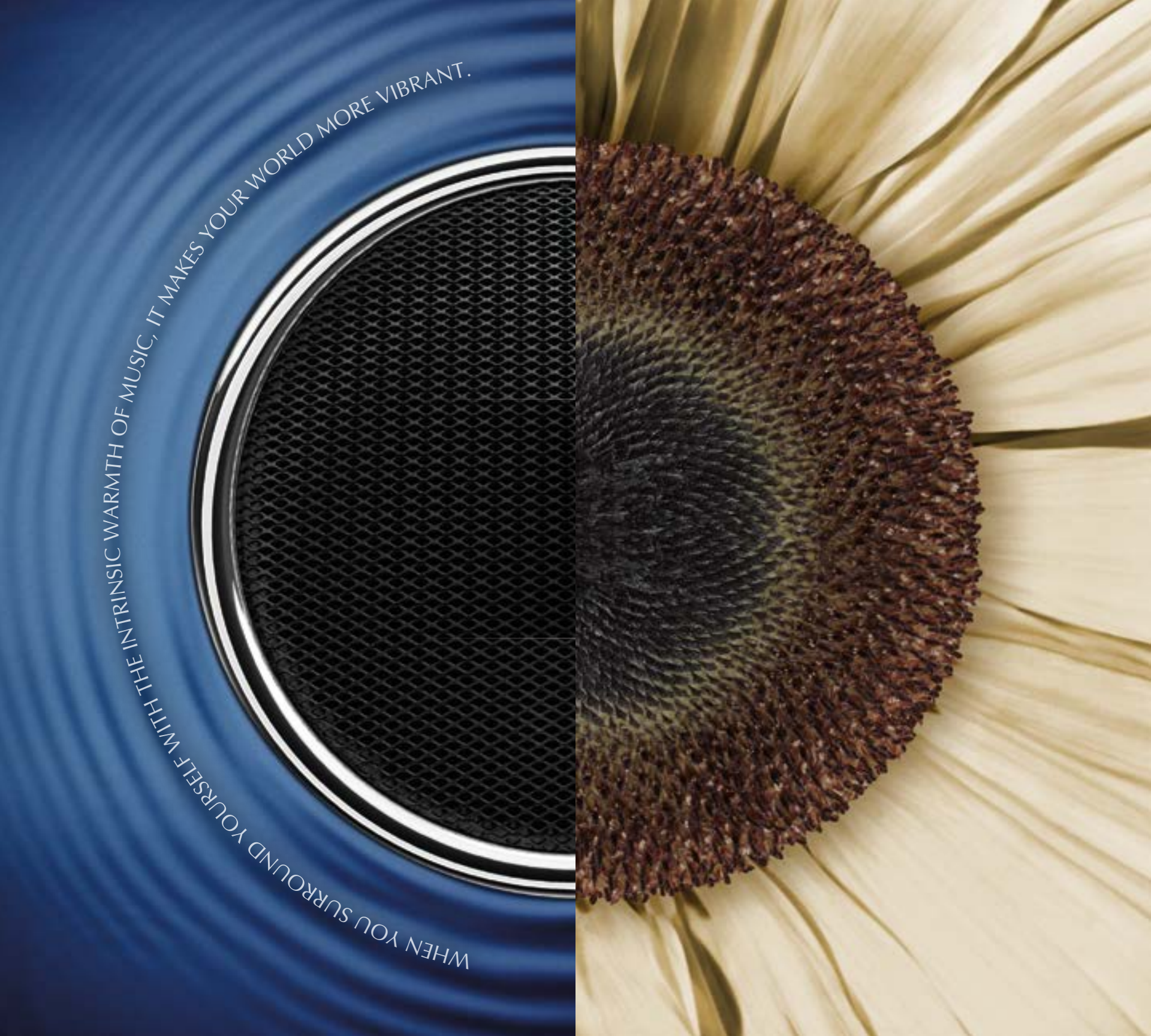

WHEN YOU SURROUND YOURSELF WITH THE INTRINSIC WARMTH OF MUSIC, IT MAKES YOUR WORLD MORE VIBRANT.



BLU-RAY™ PLAYER WITH SEATBACK-MOUNTED VIDEO SYSTEM

Two available 9-inch high-resolution screens are integrated into the seatback to entertain rear-seat passengers. The system can play standard DVDs as well as Blu-ray discs, and includes independent HDMI and RCA inputs for each screen.

WHEN YOU SURROUND YOURSELF WITH THE INTRINSIC WARMTH OF MUSIC, IT MAKES YOUR WORLD MORE VIBRANT.



19 -SPEAKER PREMIUM AUDIO

harman/kardon®

Prestige in audio craftsmanship is reflected in the premium system that arrives standard with Grand Cherokee Summit. This massively powerful system employs 19 GreenEdge speakers, delivering everything an audiophile requires for the replication of sound with the highest of standards. GreenEdge utilizes efficient speaker and amplifier engineering to improve sound quality while significantly diminishing energy consumption.

- Nine 25-mm Tweeters
- ⊕ Five 90-mm Mid-range Speakers
- Two 160-mm Mid-Woofers
- ⊖ Two 6- x 9-inch Subwoofers
- ⊙ One 10-inch Subwoofer

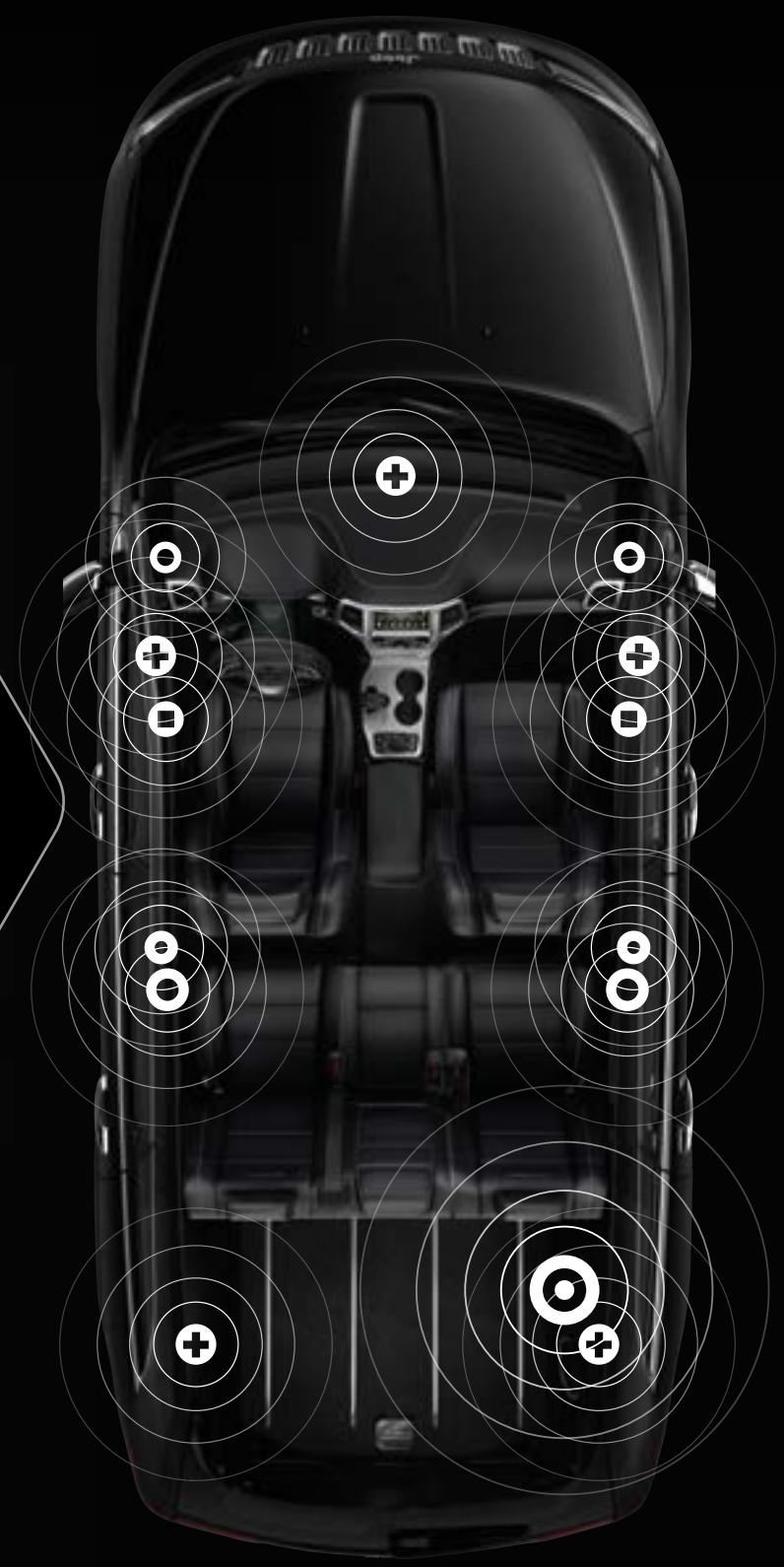

PEACE OF MIND
DELIVERED 70
AVAILABLE WAYS.
HERE ARE JUST A FEW.

THE NEW 2014 GRAND CHEROKEE DELIVERS REIMAGINED LUXURY AND REDEFINED CAPABILITY TO PERFORM HEROICALLY IN ALL DRIVING CONDITIONS. YOU'LL FEEL THE STRENGTH OF ITS REINFORCED STRUCTURE, SHELTERED WITHIN AN ENVIRONMENT THAT SERVES YOU WELL. GO BOLDLY FORTH, EMPOWERED WITH INSPIRED CONFIDENCE.

UCONNECT® ACCESS WITH 9-1-1 AND ROADSIDE ASSISTANCE. A fast and direct connection to help is right at hand with Uconnect Access, the next benchmark in emergency vehicle assistance. Two buttons conveniently located on the rearview mirror offer an instant lifeline. Press "9-1-1" for an immediate connection to a 9-1-1 call center, or press "ASSIST" to quickly summon roadside help. Available.

UCONNECT VOICE COMMAND. Multitasking is the way of today's world, even when you're on the road. Uconnect Voice Command allows drivers to safely send, reply, or listen to a text, take or make phone calls, request real-time information like fuel prices, get navigation directions, and more, while keeping both hands on the wheel. Available.

ELECTRONIC STABILITY CONTROL (ESC).® A vehicle-wide network of safety sensors helps maintain vehicle control, providing instant aid should they detect you're veering off your intended path. ESC coordinates Electronic Roll Mitigation (ERM), antilock brake system (ABS) and Brake Assist, all-speed traction control, and available Trailer Sway Control (TSC), sending them into action when needed. Standard.

PARKVIEW® REAR BACK-UP CAMERA.® Back out safely with grace. This system helps bring previously hidden rear objects to your attention, either on-screen or with an audible warning, in good time to react. Available.

PARKSENSE® FRONT AND REAR PARK ASSIST SYSTEMS.® Available Front Park Assist system helps you nestle into parking spots by detecting objects in front of the vehicle and providing an audible warning when you are too close for comfort. When a side or rear blind spot is encroached, you're notified via illuminated icons on sideview mirrors or an audible chime.

A SECURE AIR BAG SYSTEM.® Your sense of security is fully met with Grand Cherokee's all-around air bag system. Full-length side-curtain, seat-mounted side thorax, advanced multistage front, and driver inflatable knee blocker air bags all work in tandem to help provide protection. Standard.

ADAPTIVE CRUISE CONTROL (ACC).® Take the guesswork out of keeping a safe distance from the car ahead while cruising on the highway. The ACC automatically adjusts cruising speed to maintain a preset distance between your Grand Cherokee and the vehicle in front of you. Available.

ADAPTIVE HID HEADLAMPS/ DAYTIME RUNNING LAMPS/ HEADLAMP WASHERS. They follow your cue as you turn the wheel, illuminating curves in the road ahead and helping to reveal what was once hidden. Available Signature LED Daytime Running Lamps add even greater visibility. Optional Headlamp Washers keep your lenses free of debris.

TRAILER SWAY CONTROL (TSC). Crosswinds and traffic hold no sway over you and your payload. As part of ESC,® TSC helps keep you and the toys you are towing safely on course.

BLIND SPOT MONITORING® AND REAR CROSS-PATH DETECTION SYSTEM.® These sentry systems constantly monitor the space between you and other drivers. When a side or rear blind spot is encroached, you're notified via illuminated icons on sideview mirrors or an audible chime. Available.

ELECTRONIC ROLL MITIGATION (ERM). As an extension of ESC,® ERM employs ESC sensors to anticipate potential risk situations. If things get rough, ERM takes immediate action to help you maintain stability and remain under control. Standard.

SELEC-SPEED™ CONTROL. Smoothly navigating steep hills can be daunting. Engage Selec-Speed Control on the Selec-Terrain® dial of your 4WD Grand Cherokee and you'll climb and descend with greater safety. Fuses Hill Ascent Control and Hill Descent Control into one incredibly capable feature. Available.

SENTRY KEY® ENGINE IMMOBILIZER. A unique, embedded key code matched only to your vehicle helps keep your Grand Cherokee safely where it belongs.

RAIN-SENSING WIPERS AND RAIN BRAKE SUPPORT. Storm clouds hold little influence over your daily drive. Front wipers activate when raindrops are detected, and a smart brake system helps dry the brake rotors on wet roads. Available.

FORWARD COLLISION WARNING (FCW)™ WITH CRASH MITIGATION. Radar sensors detect when Grand Cherokee may be approaching another vehicle too rapidly and sends an audible and visual alert to the driver. The system also provides 1.5 seconds of braking assistance if the driver does not react in time.



SUMMIT SHOWN IN CASHMERE PEARL

LAREDO SHOWN IN DEEP CHERRY RED CRYSTAL PEARL, LIMITED SHOWN IN BILLET SILVER METALLIC, OVERLAND® SHOWN IN CASHMERE, SUMMIT SHOWN IN AUBURN PEARL, SRT® SHOWN IN BRIGHT WHITE



OPEN THE DOOR TO A REMARKABLE EXPERIENCE

LAREDO. Keyless Enter 'n Go; Quadra-Trac I® 4WD (4x4 models only); 3.6L V6 VVT engine; 8-speed automatic transmission; steering-wheel paddle shift control; 7-inch configurable Multi-View Display (EVIC); front and rear air bags;¹⁷ 17-inch painted aluminum wheels; projector fog lamps; daytime running headlamps; Uconnect® 5.0 radio (5-inch touch screen, six speakers, and USB media hub); capless fuel fill door; LED taillamps; interior lighting for front footwell, center console bin

LIMITED. Includes Laredo features, plus or replacing: Quadra-Trac II® with Selec-Terrain® and Hill Descent Control (4x4); heated steering wheel; leather-trimmed seating; power eight-way passenger seat with four-way lumbar adjustment; heated front-row and second-row seating; 18-inch polished aluminum wheels; ParkSense® Rear Park Assist® and ParkView® Rear Back-Up Camera® with Dynamic Grid Lines; premium audio system with nine speakers, including subwoofer; unique Limited lower fascia; dual exhaust; bright door handles; power, heated, multifunctioning chrome mirrors; Capri leather; strakes in rear cargo; door sill scuff pads with bright insert and Jeep® logo

OVERLAND®. Includes Limited features, plus or replacing: Quadra-Lift® Air Suspension system (4x4); Bi-xenon HID headlamps with LED daytime running lamps; unique Overland grille; power folding mirrors with puddle lamps; rain-sensing wipers; Nappa Leather-trimmed ventilated front seats and leather-stitched instrument panel, door uppers, and center console armrest; real wood and leather-wrapped heated steering wheel; dual-pane sunroof; chrome tow hooks; power liftgate; power tilt/telescoping steering wheel; 20-inch polished wheels with Mineral Gray pockets; Uconnect® navigation radio with 8.4-inch touch screen

SUMMIT. Includes Overland features plus or replacing: suede-like headliner; Natura Plus leather-trimmed seating; Harman Kardon® premium sound system with 19 speakers, including 10-inch subwoofer; adaptive headlamps; headlamp washers; Front Park Assist;¹⁸ 20-inch full polished wheels with Satin clear-coat; Blind Spot Monitoring;¹⁹ Forward Collision Warning;¹¹ Adaptive Cruise Control¹²

SRT®. 6.4L V8 SRT HEMI® engine with Fuel Saver Technology; SRT leather-wrapped steering wheel with audio, EVIC, and cruise controls; SRT Performance Pages; Uconnect Voice Command with Bluetooth®; Keyless Enter 'n Go; Quadra-Trac® Active On-Demand 4-Wheel-Drive System; Selec-Track® Adaptive Damping Suspension with Track, Sport, Auto, Snow, and Tow Modes; Electronic Limited-Slip Rear Differential; SRT Performance Brakes with 6-Piston front/4-Piston rear Brembo® Calipers; Uconnect navigation radio with 8.4-inch touch screen; dual heat extractors on hood; steering-wheel-mounted paddle shifters; Adaptive Speed Control.¹² Visit driveSRT.com



jeep.com (800) 925-JEEP

(1) 2012 *Ward's* Mid-Size Sport Utility Vehicle segmentation (excludes Chrysler Group LLC vehicles). 3.0L Diesel: Over 730 miles range on one tank @ 30 mpg. 3.6L V6: Over 630 miles range on one tank @ 25 mpg. (2) 2012 *Ward's* Mid-Size Sport Utility Vehicle segmentation (excludes Chrysler Group LLC vehicles). Equipped with V8 4x2 or 3.0L Diesel 4x2, 7,400 lbs towing capacity. (3) 2012 *Ward's* Mid-Size Sport Utility Vehicle segmentation (excludes Chrysler Group LLC vehicles). Based on Off-Road Group 2 air suspension height 8.9" -11.3". (4) 2012 *Ward's* Mid-Size Sport Utility Vehicle segmentation (excludes Chrysler Group LLC vehicles). Based on available Transfer Case and Off-Road Group 2 capabilities. (5) 2012 *Ward's* Mid-Size Sport Utility Vehicle segmentation (excludes Chrysler Group LLC vehicles). Equipped with V8 4x2, 390 lb-ft of torque, or 3.0L Diesel 4x2, 420 lb-ft of torque. (6) Jeep Grand Cherokee has received more awards over its lifetime than any other SUV. (7) 2012 *Ward's* Mid-Size Sport Utility Vehicle segmentation (excludes Chrysler Group LLC vehicles). Based on Summit model offerings. (8) 2012 *Ward's* Mid-Size Sport Utility Vehicle segmentation (excludes Chrysler Group LLC vehicles). 3.0L V6 Diesel 4x2 @ 30 mpg. (9) Late availability. (10) No system, no matter how sophisticated, can repeal the laws of physics or overcome careless driving actions. Performance is limited by available traction, which snow, ice, and other conditions can affect. When the ESC warning lamp flashes, the driver needs to use less throttle and adapt speed and driving behavior to prevailing road conditions. Always drive carefully, consistent with conditions. Always wear your seat belt. (11) FCW system is solely an alert system for the front of the vehicle which does not take any actions to change vehicle dynamics to avoid a collision, not a substitute for active driver involvement. The driver must remain aware of traffic conditions and be prepared to use brakes to avoid collisions. (12) ACC is a driver convenience system, not a substitute for active driver involvement. The driver must remain aware of traffic conditions and be prepared to use brakes to avoid collisions. (13) Chrysler estimated 30 highway mpg. 3.0L Turbo EcoDiesel V6 engine and 8-speed transmission. Final EPA mileage not available at time of publication. Use for comparison purposes only. (14) Do not attempt water fording unless depth known to be less than 20 inches. Traversing water can cause damage that may not be covered by the new vehicle warranty. Always off-road responsibly in approved areas. (15) SiriusXM service requires a subscription, sold separately after 12-month trial included with vehicle purchase. **If you decide to continue your SiriusXM service at the end of the trial subscription, the plan you**

choose will automatically renew and bill at the current rates until you call SiriusXM at 1-866-635-2349 to cancel. See our Customer Agreement for complete terms at siriusxm.com. Sirius satellite service is available only to those at least 18 and older in the 48 contiguous United States, D.C., and P.R. (with coverage limitations). SiriusXM Traffic available in select markets. See siriusxm.com/traffic for more information. Sirius, XM, and all related marks and logos are trademarks of SiriusXM Radio Inc. (16) Always look before proceeding, electronic drive aid is not a substitute for conscientious driving, always be aware of your surroundings. (17) The Advanced Front Air Bags in this vehicle are certified to the new U.S. federal regulations for advanced air bags. Children 12 years old and younger should always ride buckled up in a rear seat. Infants in rear-facing child restraints should never ride in the front seat of a vehicle with a passenger front air bag. All occupants should always wear their lap and shoulder belts properly. (18) Always check visually for vehicles prior to changing lanes.

This brochure is a publication of Chrysler Group LLC. All product illustrations and specifications are based upon current information at the time of publication approval. Chrysler Group LLC reserves the right to make changes from time to time, without notice or obligation, in prices, specifications, colors, materials, and to change or discontinue models, which are considered necessary to the purpose of product improvement or for reasons of design and/or marketing. Jeep, the Jeep grille, Grand Cherokee, CommandView, Go Anywhere, Do Anything, HEMI, Laredo, Mopar, Overland, ParkSense, ParkView, Pentastar, Quadra Drive, Quadra-Lift, Quadra Trac, Quadra-Trac I, Quadra-Trac II, Sentry Key, Selec-Terrain, Selec-Track, SRT, Trail Rated, and Uconnect are registered trademarks and Selec-Speed and Summit are trademarks of Chrysler Group LLC. Alpine and the Alpine logo are registered trademarks of Alpine Electronics, Inc. All rights reserved. Bluetooth is a registered trademark of Bluetooth SIG, Inc. Blu-ray Disc is a registered trademark of Blu-ray Disc Association. Brembo is a registered trademark of Freni Brembo S.p.A. Harman Kardon is a registered trademark of Harman International Industries, Inc. iPad, iPhone, iPod, and iTunes are registered trademarks of Apple Inc. Sirius, XM, and all related marks and logos are trademarks of SiriusXM Radio Inc. © 2013 Chrysler Group LLC. All rights reserved.

Jeep

jeep.com (800) 925-JEEP