

CADILLAC
data book 1965

**so new . . . so right . . .
so obviously Cadillac!**

The integrity of Cadillac Styling, Engineering and Production has earned for the Cadillac motor car a unique and dual distinction. First, it continues to enjoy a greater demand, year after year, than any luxury motor car ever created. Secondly, this ever widening field of Cadillac ownership continues to express the highest owner loyalty in the industry. Thus, while Cadillac for 1965 is indeed so new and so right . . . it is also so obviously Cadillac that even while attracting a host of first time owners it can only strengthen the deep loyalty of those to whom Cadillac pride of ownership is already an accepted way of life.

In telling the Cadillac story for 1965, it is natural and important to highlight the new styling and engineering features but, especially to first time prospects, it is equally important to spell out the long tradition of quality and integrity which has won for Cadillac its well-earned recognition as the Standard of the World.

data book sections*

	PAGES
styling Highlights of Cadillac styling for 1965 with a brief commentary on individual styling features.	6-23
body styles Illustrations of each of the eleven Cadillac body styles with basic specifications and interior dimensions, standard and optional equipment and upholstery selections for each.	24-47
optional equipment Cadillac optional equipment and accessories afford you the opportunity and responsibility of helping each owner individualize his Cadillac to his personal driving requirements.	48-63
power train (engine-transmission-drive line) Here is the story of the most responsive, dependable, smoothest and quietest performance even Cadillac owners have ever experienced.	64-75
chassis Highlight features of the Cadillac chassis with emphasis on the new frame, front and rear suspension, power steering and power braking. . . .	76-85
body Body construction features of the 1965 Cadillac and how they contribute to greater safety, convenience, comfort and roominess.	86-93
specifications Two pages of General Specifications followed by Detailed Specifications for the 1965 Cadillac. . .	94-107
milestones Year by year achievements which have earned for Cadillac its reputation as the Standard of the World and created a circle of ownership which, in numbers and loyalty, has never been approached by any other luxury motor car. . . .	108-116
index Lists all of the subjects in the Data Book alphabetically with convenient cross-referencing. . . .	117-121

*For details on Fleetwood Seventy-Five Sedan and Limousine refer to Specifications and Body Styles Sections.

Cadillac new features for 1965

styling

New exterior styling includes longer, lower silhouettes on the Calais, De Ville, Fleetwood Eldorado Convertible and Fleetwood Sixty Special Sedan. The Fleetwood Sixty Special Sedan with its exclusive new 133" wheelbase and 227.5" over-all length is also offered with a new Brougham option.

New front end styling features a wider grille and hood, dual vertical headlamps, parking lamps in the new drop center front bumper and larger cornering lamps. With a new wider front and rear tread, the new front end design accents the lower, wider, road-hugging stance of Cadillac for 1965.

New rear end styling is marked by horizontal lines of straight-across rear bumper and deck sill grille and grouping of all rear lamps in vertical chrome housings integrally designed with rear quarter panels.

New body styling includes a new flush, top contour on rear quarter panels, curved, frameless glass side windows, new rocker sill moldings on Fleetwood models, new side moldings on Calais and De Ville models and new wheel discs on all models. Convertibles have new tempered rear window glass.

New interiors provide increased spaciousness, lower floor tunnels, new trim styles and upholstery, new instrument panel styling and greater convenience of all controls.

chassis

New perimeter frame design permits forward mounting of engine thus resulting in lower floor tunnel height and increased interior roominess. New body to frame mounting isolates road noise for greater quietness.

New front and rear suspension contributes to greater comfort and stability and a more level ride.

New whitewall tires (optional at extra cost except on the Fleetwood Eldorado Convertible) contribute to lower silhouette of the car and have tread design extended onto shoulder of tire for smoother, quieter cornering.

New drive line with one-piece propeller shaft with constant velocity joints, more rigid rear axle housing and pre-stressed wheel bearings assures maximum dependability, quietness and long life. (Two-piece propeller shaft on Fleetwood 75 models.)

New Turbo Hydra-Matic has variable stator (except on Fleetwood 75 models) for increased selectivity of acceleration and now provides two Drive range positions, one for normal driving conditions, the other for hilly or mountainous terrain and increased engine braking.

engine

New engine features include specially designed mountings for maximum idling smoothness, computer designed 7-blade fan and new cross-flow radiator for increased cooling efficiency and quietness, improved electrical system for surer starting and a revolutionary new coaxial resonator exhaust system sonically balanced for maximum quietness.

optional equipment

New Twilight Sentinel and Guide-Matic controls are located in headlamp switch nacelle for added convenience. Guide-Matic photocell is newly located behind radiator grille for maximum sensitivity to headlamps and taillights of other cars but without interference from overhead lighting.

New location of Comfort Control components on engine side of dash panel permits greater front compartment roominess. Larger heater floor duct for 1965 assures improved distribution of air to rear compartment.

New Cruise Control has illuminated dial and new lock-in switch for automatic cruising which requires no re-setting after brake application.

New Automatic Level Control automatically levels the car to compensate for any increase or decrease in loading of rear compartment or luggage compartment or for trailer towing. Standard on Fleetwood Eldorado Convertible and Sixty Special Sedan and with Brougham option.

New Power Door Locks are activated by front door lock push buttons. New provision unlocks all doors when either front door is opened with inside handle or by unlocking either door with key.

1965 Cadillac Styling

For 1965, Cadillac presents a styling concept certain to attract a host of new admirers while further entrenching itself in the affections of present Cadillac owners. It is so new . . . from grille and vertical headlamps to rear quarter panel and rear lamp housings . . . as to excite the interest of any viewer.

It is so right . . . in its balanced proportions and sleek symmetry . . . that even the most discerning fine car connoisseur must voice assent. It is so obviously Cadillac . . . in the strength, dignity and inherent integrity of its design . . . that your most dedicated Cadillac owners will be quick to acclaim this newest creation in the Cadillac tradition.

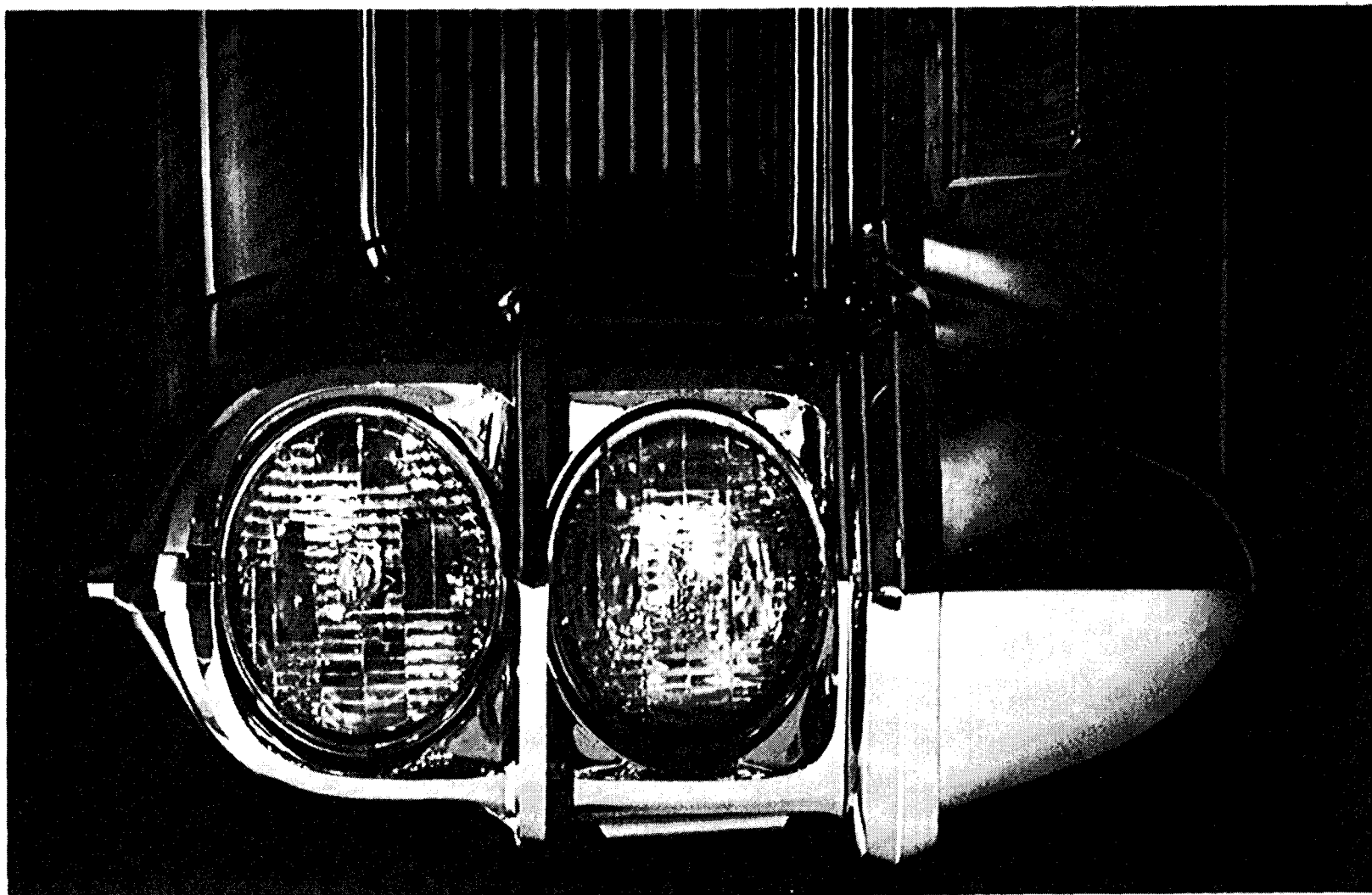

Fleetwood Sixty Special Sedan

Newest of the Cadillac family for 1965 is the magnificent Fleetwood Sixty Special Sedan. It truly stands alone among the world's luxury sedans with its exclusive new 133-inch wheelbase and all that this connotes in riding quality and roominess. And in its new longer length. And of course, it bears the identifying Wreath and Crest insignia, distinctive rocker sill moldings and rich interior appointments exclusive to the Fleetwood name. Here indeed, is the luxury sedan whose elegance, grace and stature are certain to make it the unchallenged high fashion leader for 1965.

Fleetwood Eldorado Convertible

The sweeping lines and Fleetwood decor of the Eldorado Convertible bring open car luxury to new heights for 1965. From grille to rear lamp housings it embodies the finest in Cadillac styling advancements combined with special Fleetwood distinction. Its new stretchable, pleated top boot, for example, has a self-adhering edge which eliminates former sliding channel mounting and assures a sleek fit. And its host of luxury equipment even includes a new Level Control which automatically levels the car as necessary to compensate for rear seat, luggage compartment or trailer loading.

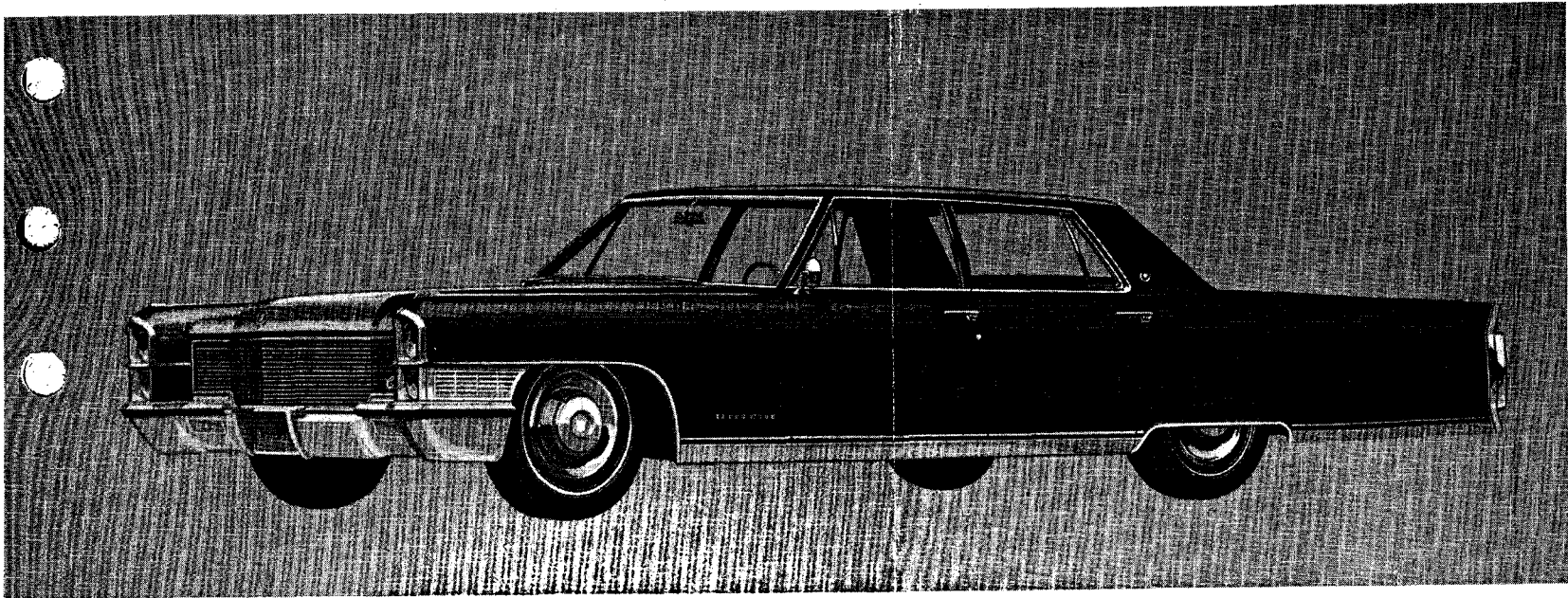

Fleetwood Sixty Special Sedan

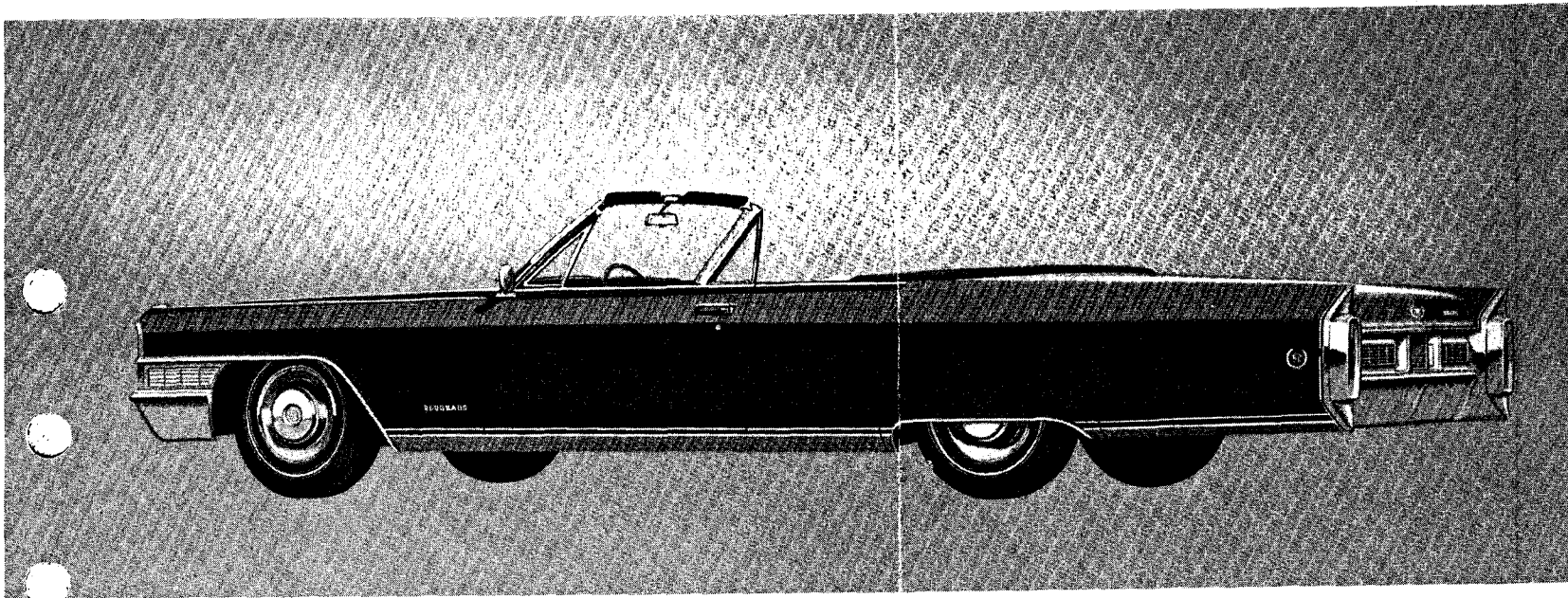

Fleetwood Eldorado Convertible

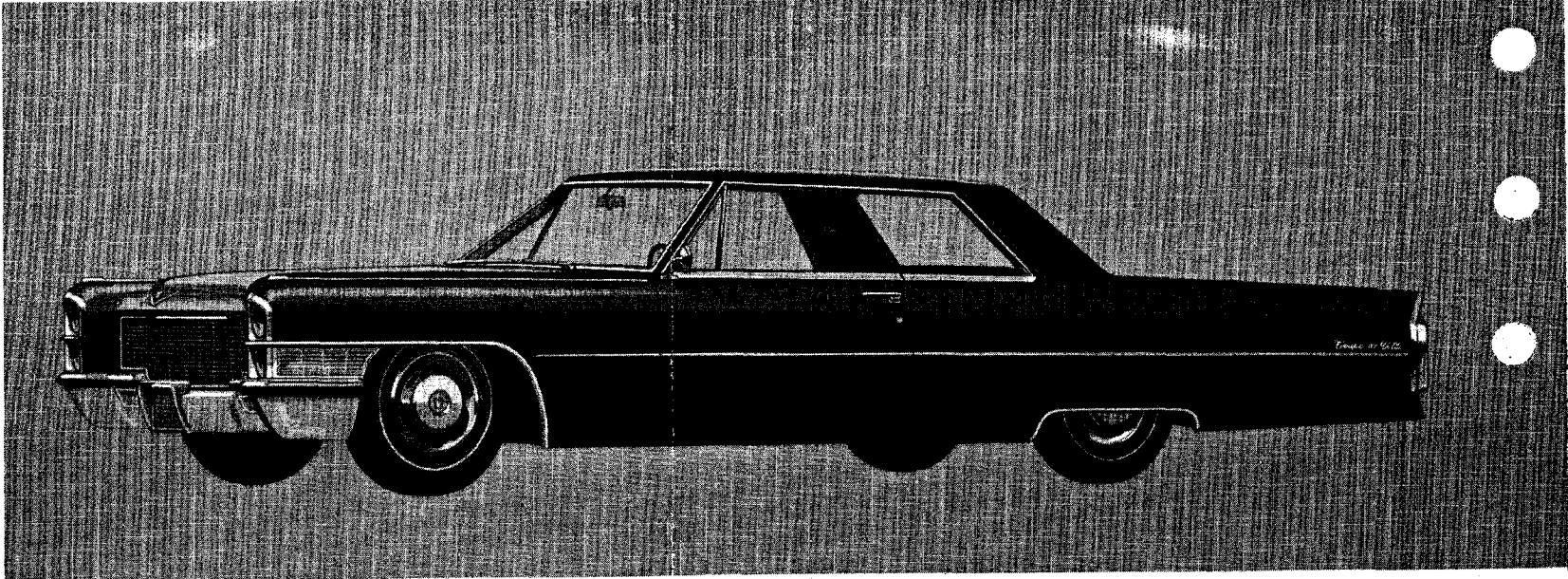

Coupe de Ville

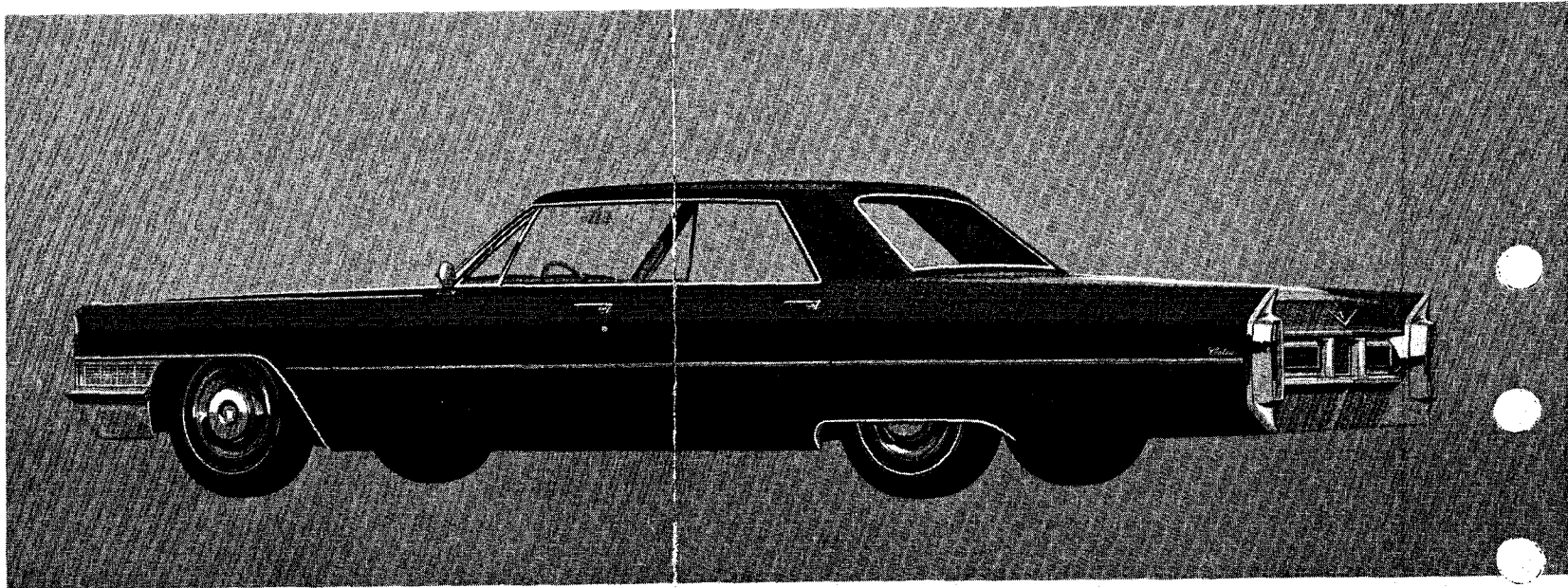

Calais Hardtop Sedan

Coupe de Ville

The elegance and distinction that have made the Coupe de Ville the world's most desirable luxury coupe were never more evident than in 1965. As with other De Ville body styles, it bears its proud name in chrome script on the rear quarter panel and has a distinguishing wide cove belt molding with brushed chrome finish. New, longer, lower lines of the Coupe de Ville feature clean, vertical side panels relieved only by a tapered chrome body side molding extending the length of the car.

Calais Hardtop Sedan

Cadillac styling for 1965, as exemplified by the Calais Hardtop Sedan, combines an aura of strength and road-hugging stability achieved not only by the actual lower over-all height, but by the positioning of vertical twin headlamps and vertical rear light housings to emphasize maximum width. The new wider radiator grille, wider hood and the new wider tread, front and rear, further contribute to Cadillac's solid stature and broad shouldered look for 1965.

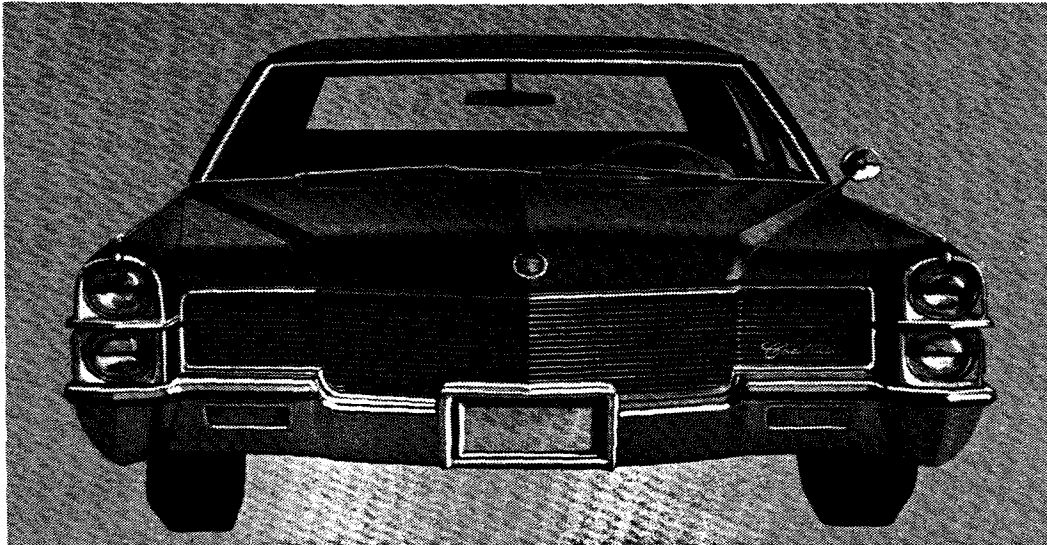

Keynoting front end styling are the wide-spaced vertical headlamps, clean uniformity of wider, chrome framed grille and the low placement of parking lamps in new drop-center front bumper. The result is strong visual emphasis on the road-hugging stability of the car itself.

New vertical headlamp location clearly indicates width of car. What's more, headlamps are not hidden by projecting fender sides as on some cars and thus are visible to drivers approaching from the side. Headlamp division bar extends into wheel opening molding for continuity of design.



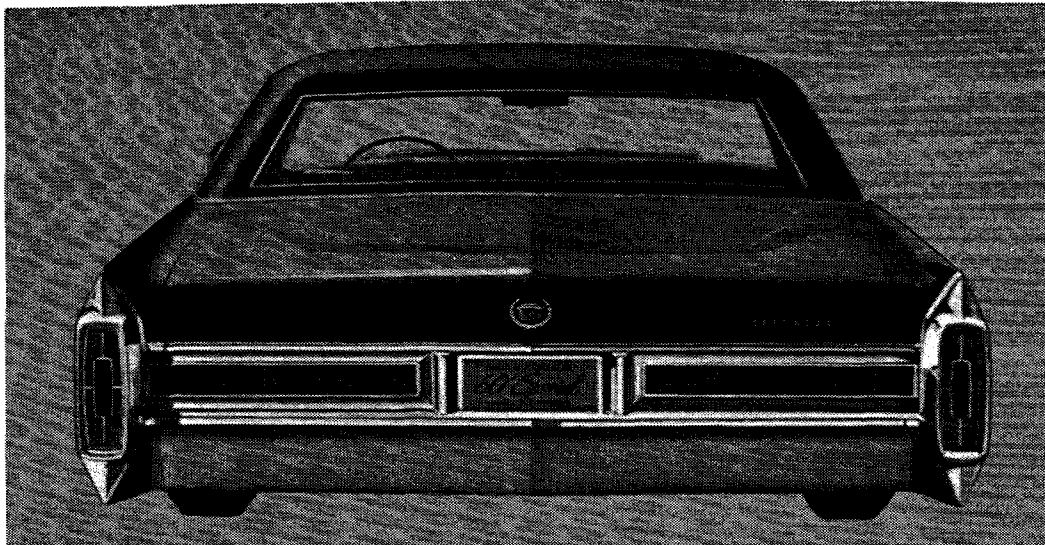

Rear ensemble presents a new unity of design. The vertical rear lamp housings perfectly complement the clean contours of new rear quarter panels. Width of car is emphasized by horizontal lines of rear deck, rear bumper and deck sill grille molding.

Integral styling of rear quarter panels and rear lamp housings imparts a feeling of massive strength and contributes to the crisp uncluttered appearance apparent throughout the length of the car. Deck sill grilles have vertical crossbars on Fleetwood models, horizontal lines only on De Ville and Calais Series.

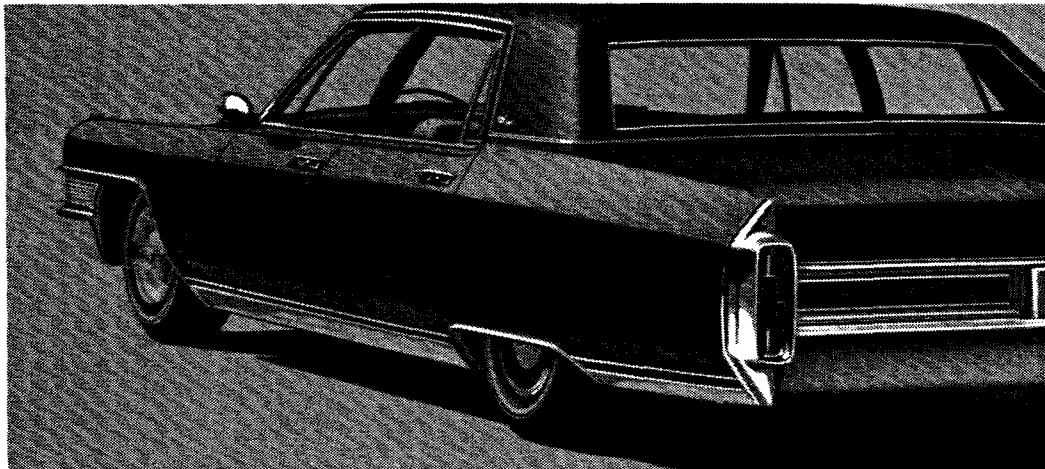

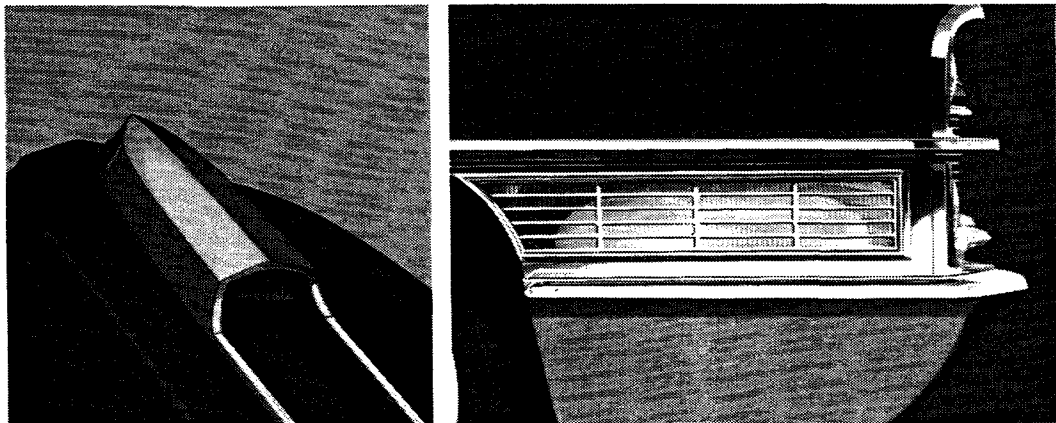
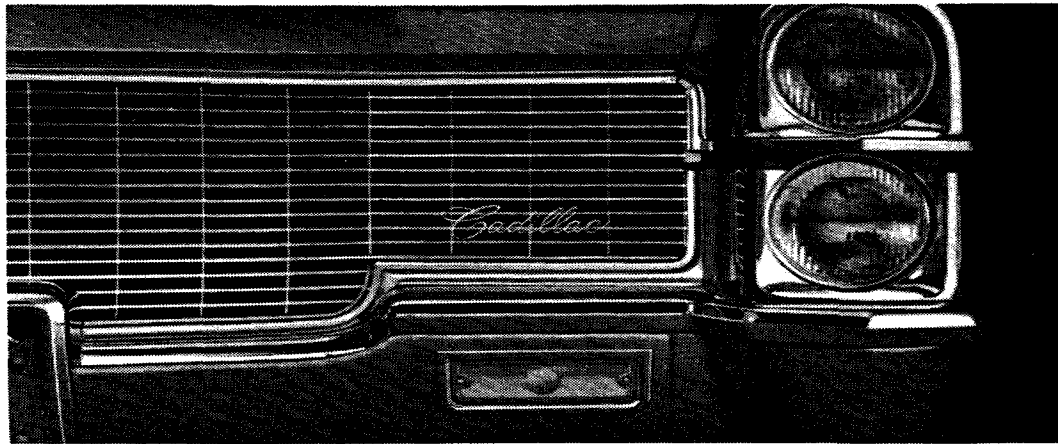

headlamps

Newly styled vertical headlamps assure efficient illumination ahead as well as on to the road shoulders. Upper lamps are lighted for normal driving, all four headlamps when bright beam floor switch is depressed.

parking and directional signal lamps

Recessed into the lower bumper bar for protection against damage from other cars' bumpers, the parking and directional signal lamps have new rectangular styling in harmony with grille and license plate holder.

directional signal indicator lamps

Located at the forward end of the front fender crown moldings, amber-lensed lights recessed into chrome housings indicate to driver direction of turn being signaled by directional signal lever.

cornering lamps

Larger for 1965 and with a newly styled protective chromed grille, cornering lamps illuminate the roadside for better visibility when rounding curves or turning corners at night.

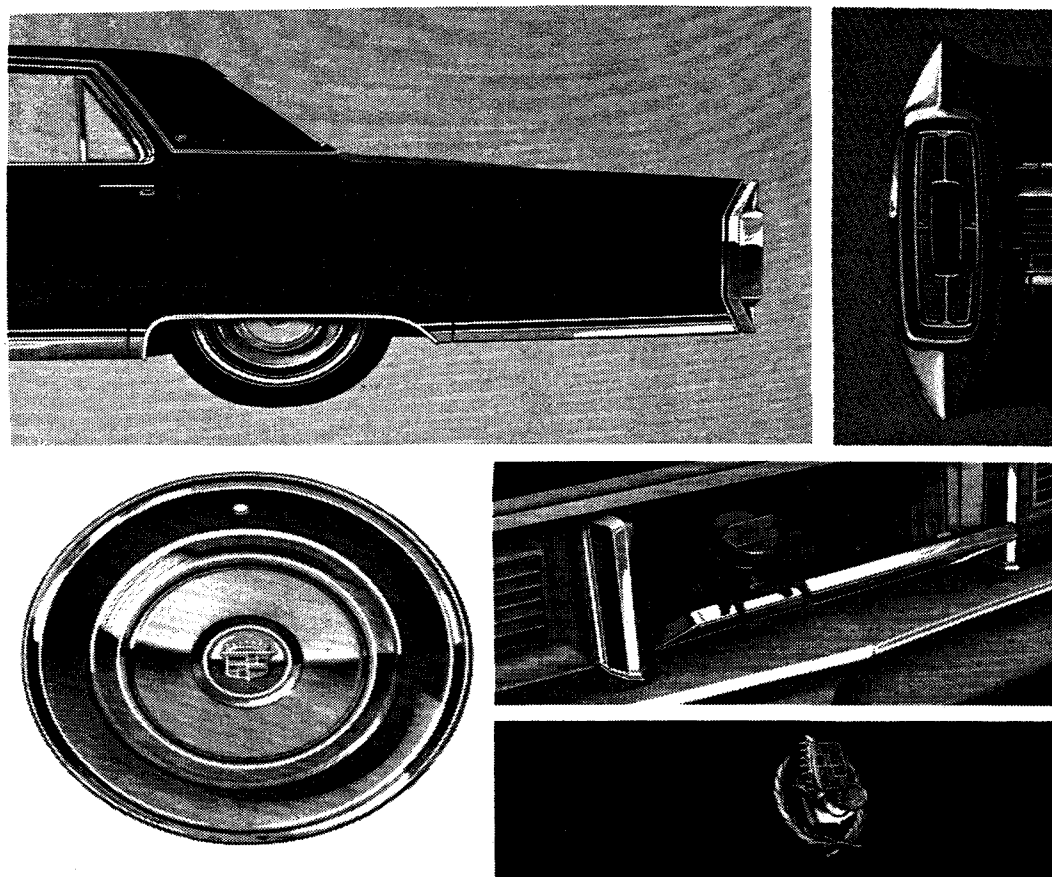

rear lamp assembly

The 1965 rear lamp assembly presents a distinctive appearance with its white lens around a rectangular red reflector. At night entire lens area shows red for stop, turn indicator or taillights, but casts a white beam of light to the rear when the shift lever is in the reverse (R) position.

wheel discs

New wheel discs of bright and brushed chrome are deeply concave with a series of concentric rings around the raised hub. Centered in the hub is the Cadillac Crest in color and chrome.

gas filler cover

Improved access to gas tank filler tube is provided by wider opening of hinged license plate holder and more accessible filler tube location.

deck lid lock

The deck lid lock is shielded from water, dirt, snow and ice by pivoted Crest section of rear deck ornamentation. Pivoting Crest to right exposes lock.

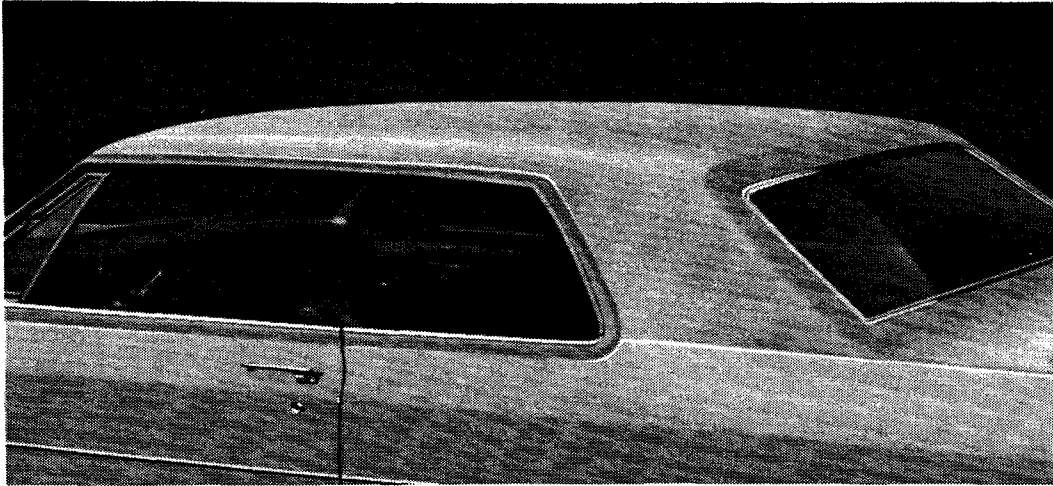

Sleekly contoured roof lines for 1965 flow smoothly into the rear deck. Coupe body styles in the Calais Series, shown above, or in the De Ville Series are a close coupled design with wide rear window pillars which enhance the apparent length of hood and rear deck.

Hardtop Sedan de Ville, shown, has a wide, bright and brushed chrome cove molding beneath the side windows. On the Calais Hardtop Sedan, body color extends up to the narrow chrome reveal molding. Padded vinyl tops are available on all De Ville models.

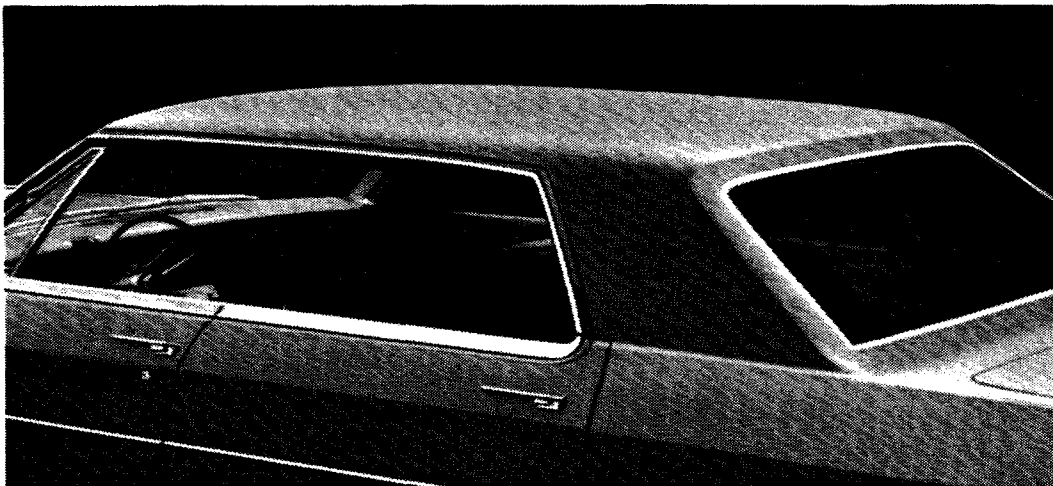

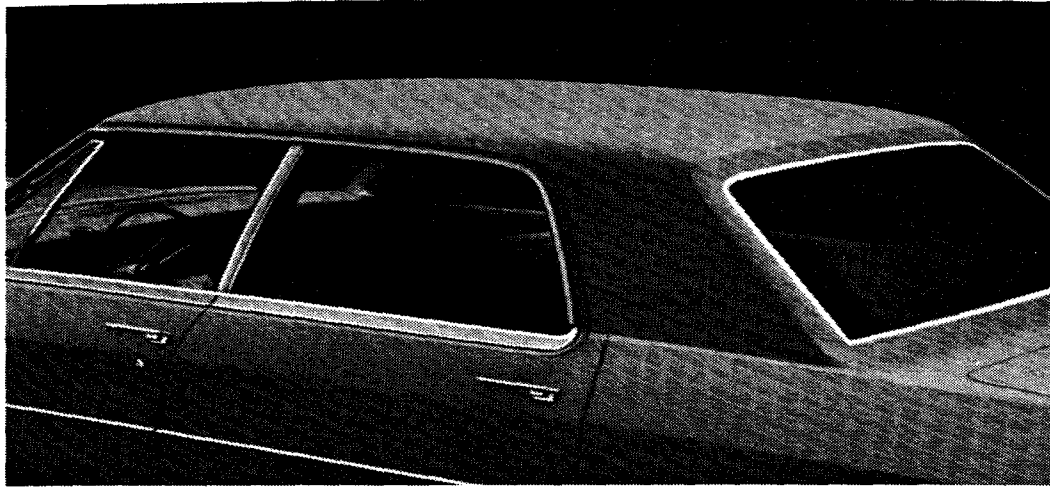

The new Sedan de Ville, shown, and Calais Sedan for 1965 have a slim new center pillar. It is gracefully curved in keeping with the new frameless glass door windows. On all Calais and De Ville Sedan models the forward edge of the rear window pillars has a sweeping rearward slant.

The exciting and entirely new Fleetwood Sixty Special Sedan has its own exclusive upper structure distinguished not only by its greater length but by curved glass rear vent windows, distinctive new full center pillar design and the Wreath and Crest on the upper rear quarter panel.

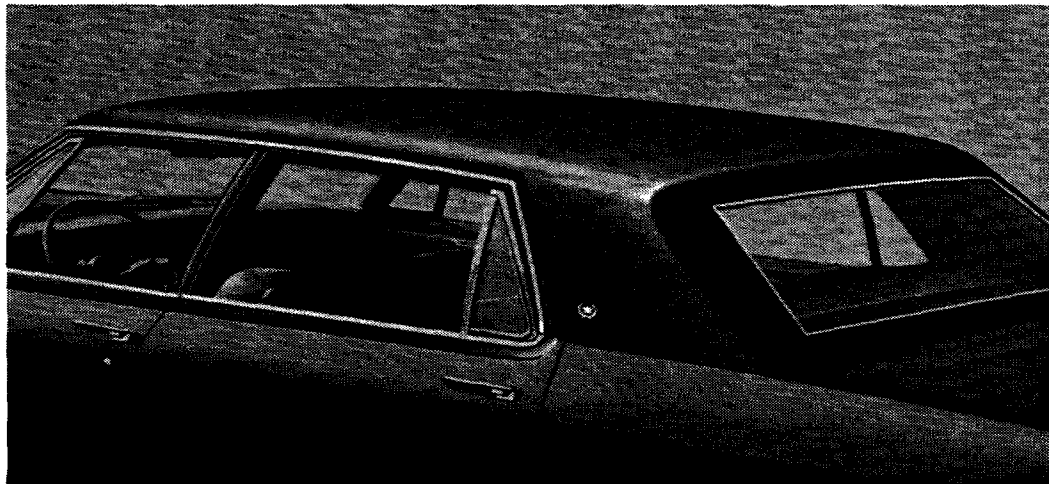

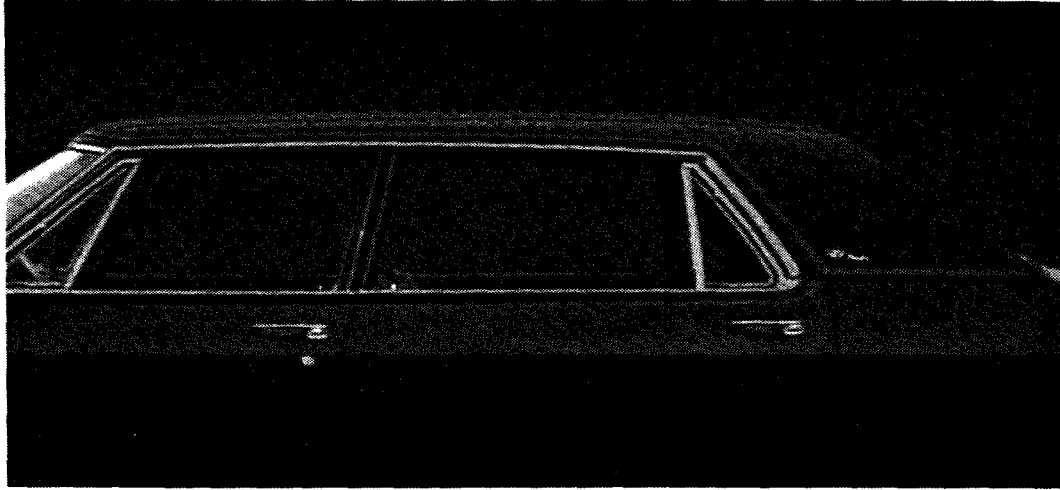

Brougham Option for the Fleetwood Sixty Special Sedan provides the special distinction of a padded, textured, coated-fabric roof covering outlined by a molding of two fine chrome lines divided by a stripe in roof color. Upper quarter panel has name Brougham in chrome script in addition to Wreath and Crest.

In keeping with the dignity and exclusiveness of the Fleetwood Seventy-Five Sedan and Limousine, these magnificent motor cars with their sculptured, angular roofline feature a rectangular rear window of restricted area and wide rear quarter panels for maximum rear compartment privacy.

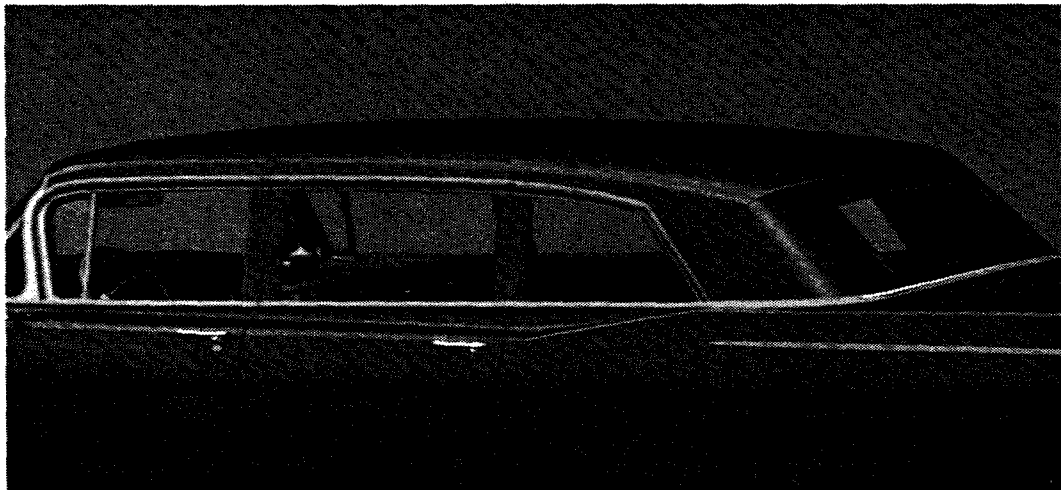

new interior styling

From the moment one opens the door of a 1965 Cadillac, it is evident that here is a new experience in interior convenience, comfort, luxury and beauty.

The driver will immediately note the smart appearance and new viewing and operating convenience of instruments and controls . . . and his passenger will find in the front compartment a new and unparalleled comfort and roominess even by Cadillac standards.

Entranceways are more spacious and the door sill lower for 1965 contributing further to Cadillac's already exceptional ease of entry or exit. And, of course, the graceful curve of the new frameless door glass, its elegance and beauty, are even more apparent when a car door is opened.

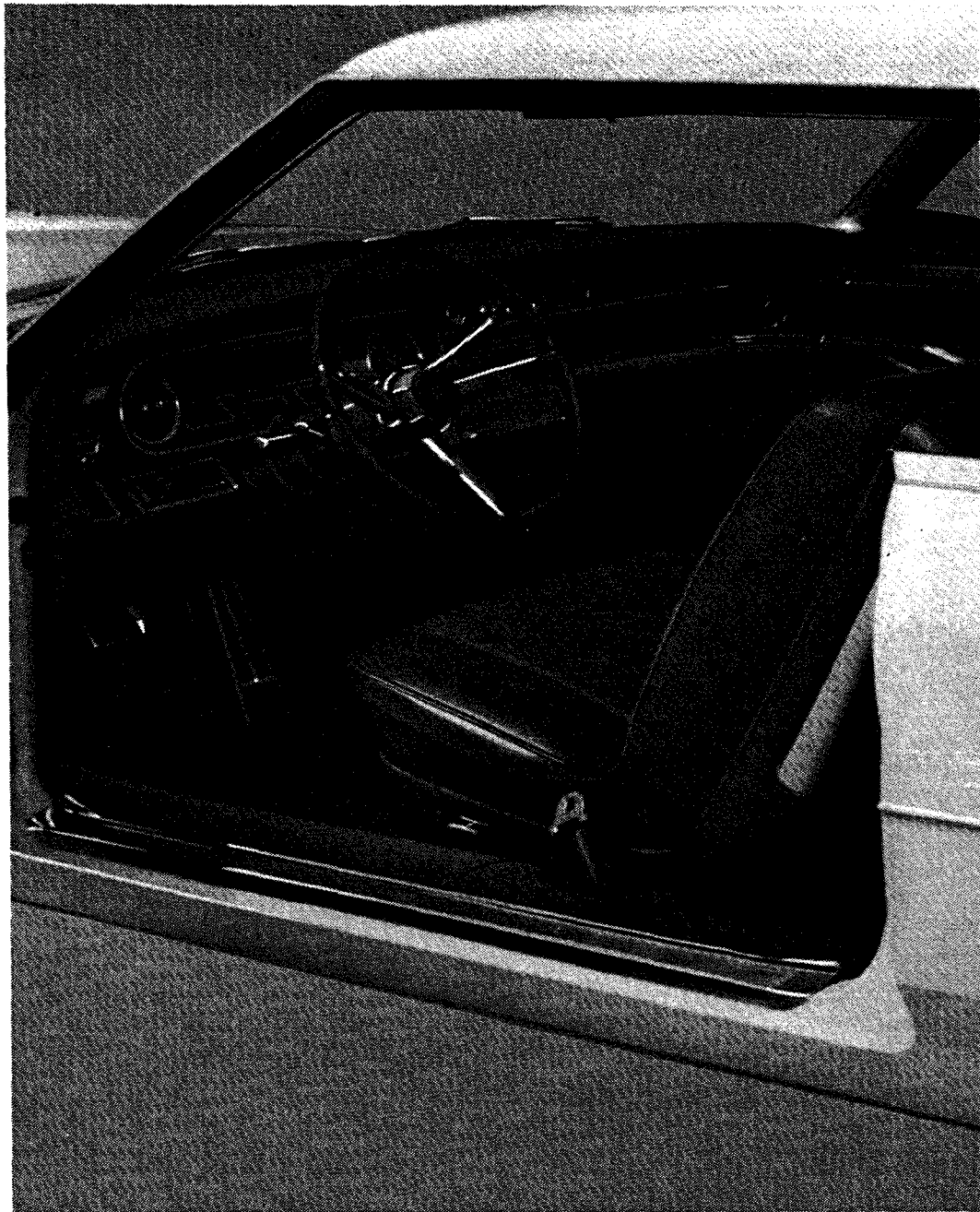

SEE INSTRUMENT PANEL ON FOLD-OUT →

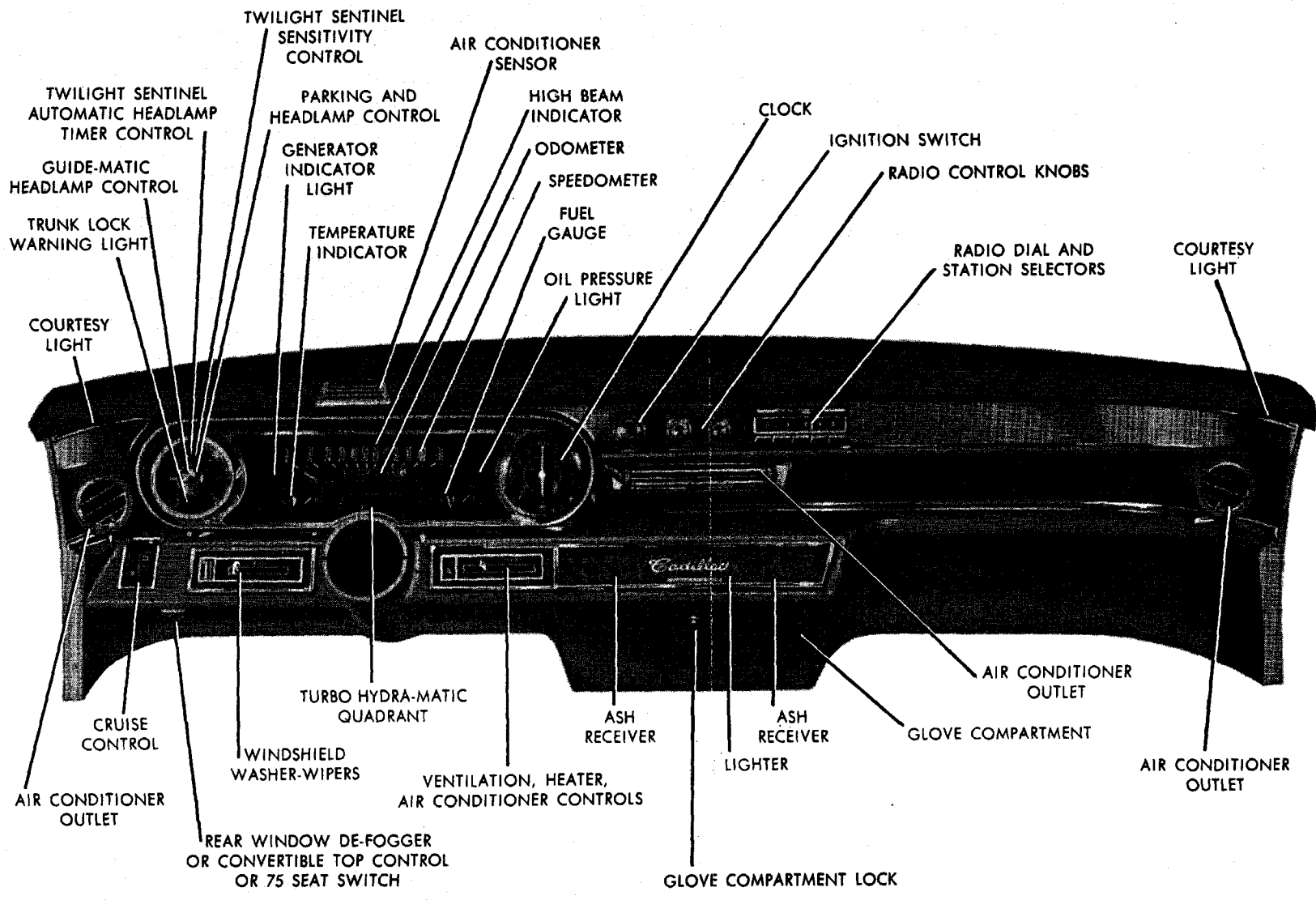

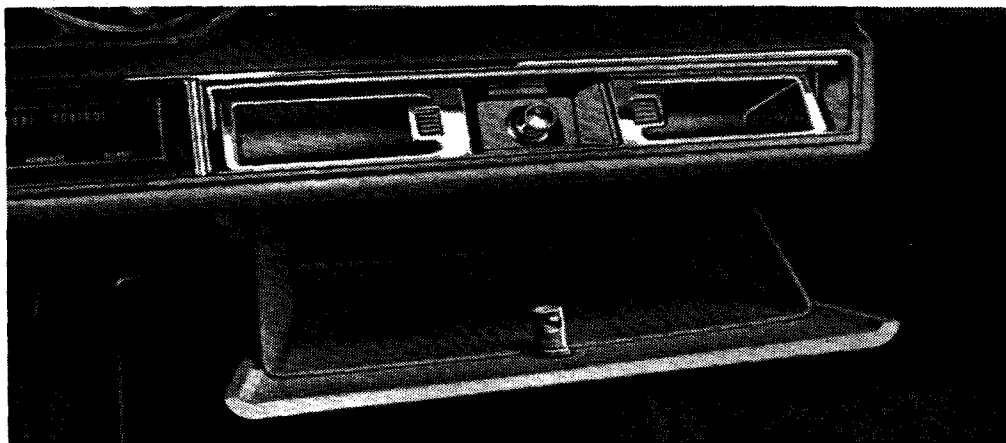

glove compartment and ash receivers

Functional beauty of the 1965 Cadillac, as evidenced throughout the car, is apparent in the convenient accessibility to driver and passengers of the centrally located cigarette lighter and dual ash receivers. Directly beneath the ash receivers is the new bin type glove compartment designed so that, when opened, its side walls prevent objects from falling out.

more spacious front passenger compartment

The added spaciousness and sense of true lounge chair relaxation enjoyed by the front seat passenger is a benefit directly attributable to the ingenuity of Cadillac engineering. Design of the new frame which permitted moving the engine forward, also permitted relocating heater and air conditioning ducts to the engine compartment leaving considerably more room ahead of the front seat passenger.



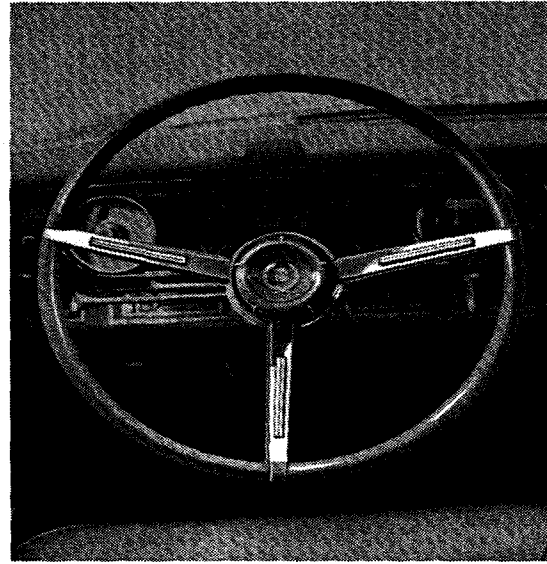
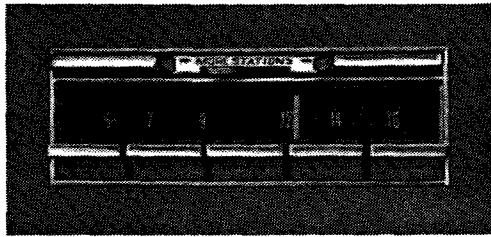
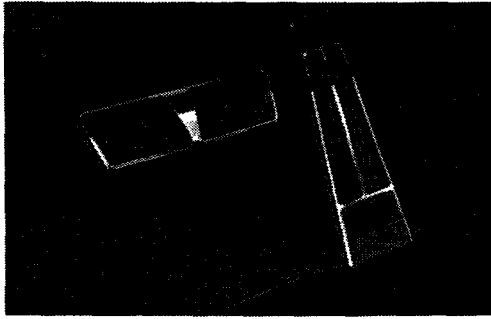

additional details of new interiors

more convenient brake pedal and accelerator operation

For 1965 the floor area beneath the brake pedal has been recessed slightly permitting a lower brake pedal more nearly level with the accelerator yet without reducing brake pedal travel. The result is faster pivoting of foot from accelerator to brake and faster, more convenient left foot application for those who prefer it. Accelerator has recess at base for high heels as a convenience to women drivers.

steering wheel

The 1965 optional extra-cost Tilt and Telescope steering wheel is a new three spoke design with horn activator bars mounted in each spoke. Insignia on the center hub is a Cadillac Crest or on Fleetwood models the Wreath and Crest. Two spoke steering wheel is provided as standard equipment.

radio controls

The radio control knobs as well as the tuning dial are now located higher up on the instrument panel where adjustment of the radio is not only more convenient but permits tuning with less of the driver's conscious attention.

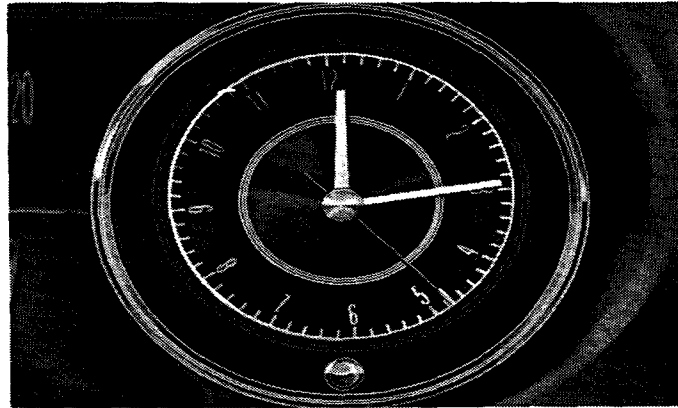
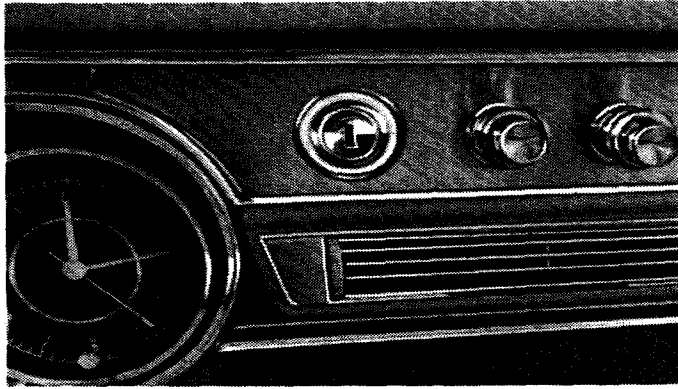

ignition switch

Newly located higher on the instrument panel, the ignition switch is more convenient and, at the same time, out of the way of any likelihood of contact with driver's knees.

coupe front seat center armrest

Now provided on all Cadillac coupe models is a wide, front seat center armrest. This comfort and convenience feature also serves to divide the coupe seat backs so that they both may be inclined forward at the same time to aid rear seat passengers as they enter or leave the car.

larger, more legible electric clock

Designed to complement the headlamp switch nacelle at the left side of the instrument cluster, the new Cadillac electric clock is larger for 1965 and illuminated at night. It is clearly legible even to rear compartment passengers.

1965 Cadillac body styles

The wide range of Cadillac body styles enables you to meet the requirements of every luxury motor car prospect. Here, along with exterior illustrations of each body style, are fold-out pages which permit you to show the interior of each model at the same time. In addition, there is a complete listing of Standard and Optional Equipment, Upholstery Selections, Basic Specifications and Interior Dimensions for each body style.

Calais Coupe.....	Page 26
Calais Hardtop Sedan.....	Page 28
Calais Sedan.....	Page 30
De Ville Convertible.....	Page 32
Coupe de Ville.....	Page 34
Hardtop Sedan de Ville.....	Page 36
Sedan de Ville.....	Page 38
Fleetwood Eldorado Convertible.....	Page 40
Fleetwood Sixty Special Sedan*.....	Page 42
Fleetwood Seventy-Five Sedan and Limousine.....	Page 46
*Brougham Option.....	Page 44

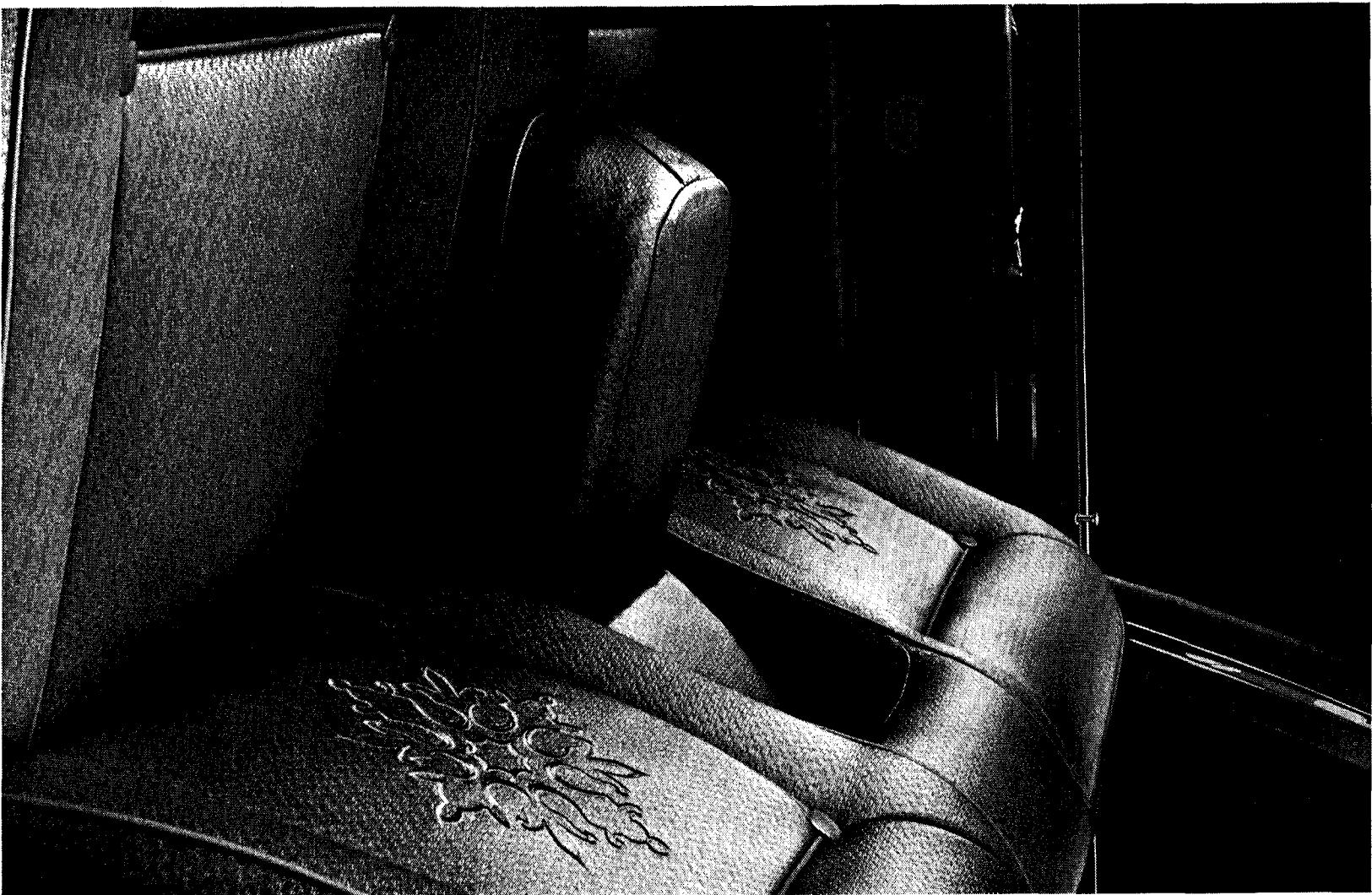

Cadillac
Calais Coupe
nineteen hundred sixty-five

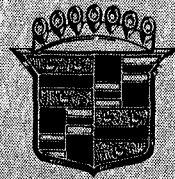

26

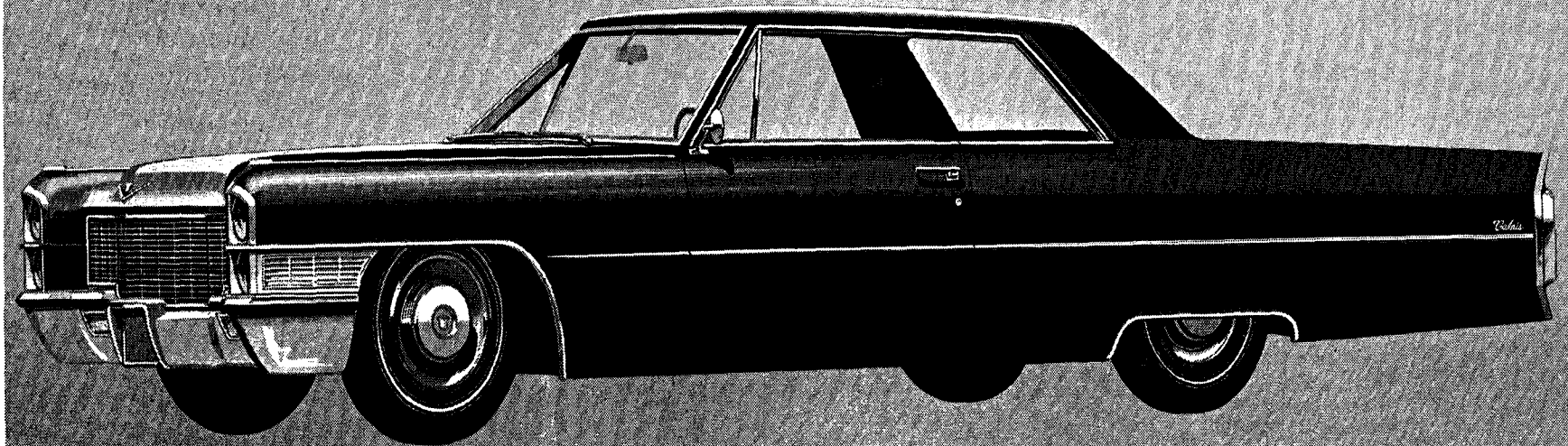

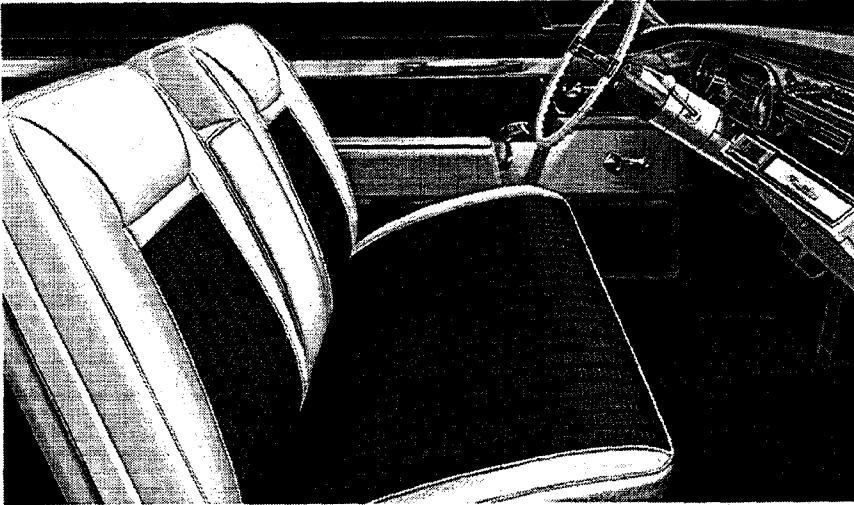
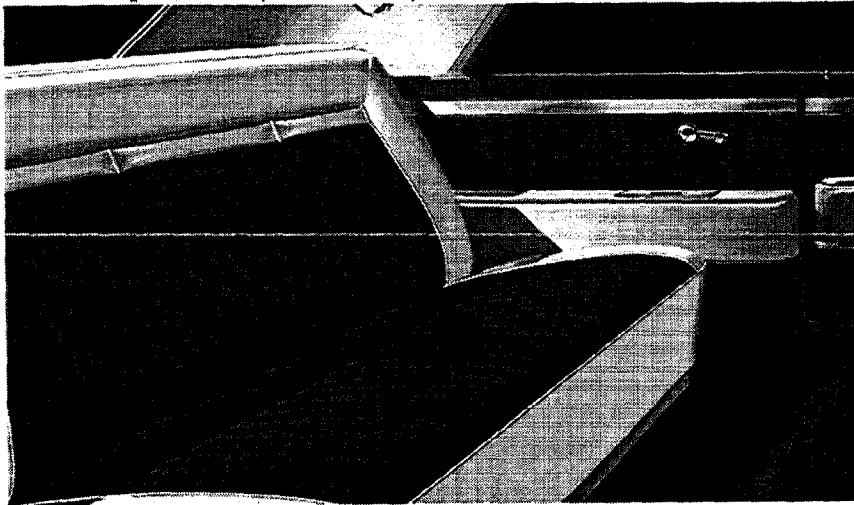
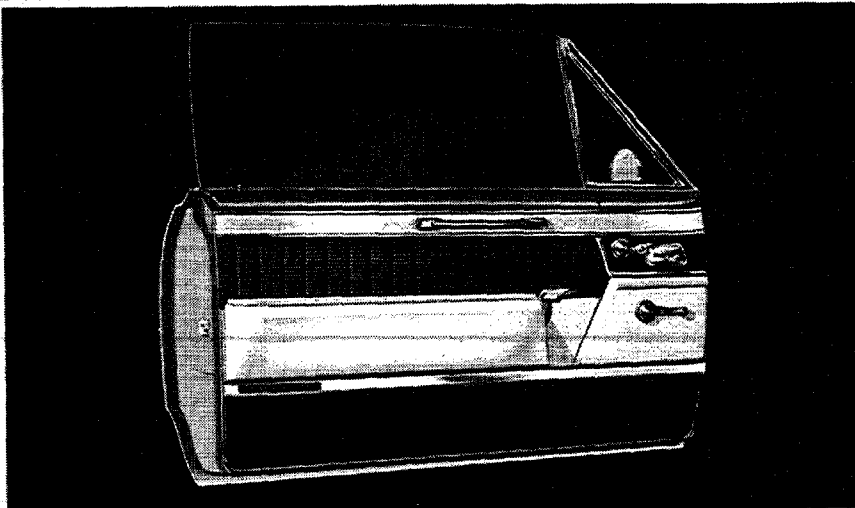
Front Compartment (Delhi Cloth)*Rear Compartment (Delhi Cloth)**Door Panel*

upholstery selections

CODE

- 210. Black Basket Weave Delhi Cloth with White Coated Fabric bolsters and trim.
- 216. Gray Basket Weave Delhi Cloth with Gray Coated Fabric bolsters and trim.
- 220. Blue Pin Stripe Delmar Cloth with Blue Coated Fabric bolsters and trim.
- 226. Midnight Blue Basket Weave Delhi Cloth with Midnight Blue Coated Fabric bolsters and trim.
- 228. Turquoise Pin Stripe Delmar Cloth with Turquoise Coated Fabric bolsters and trim.
- 230. Green Pin Stripe Delmar Cloth with Green Coated Fabric bolsters and trim.
- 241. Sandalwood Basket Weave Delhi Cloth with Sandalwood Coated Fabric bolsters and trim.

↑ Calais Coupe

standard equipment

Air Cleaner, dry-pack
 Armrest, center-front
 Cigarette Lighter, front
 Clock, electric
 Heater-Defroster*
 Light, front ash receivers
 Lights, backup (dual)
 Lights, cornering
 Lights, courtesy

Lights, directional signal
 Light, glove box (automatic)
 Light, luggage compartment (automatic)
 Lights, reading
 Mirror, glareproof, rear-view, flip type, shatterproof
 Oil Filter, Full-Flow
 Outside Mirror, left side, remote-control
 Power Brakes

Power Steering
 Reflectors, door panel, safety warning
 Seat Belts, front*
 Turbo Hydra-Matic Transmission
 Visor Vanity Mirror, shatterproof
 Visors, dual sun
 Wheel Discs (set of four)
 Windshield Washer and Coordinator
 *Available without heater-defroster or seat belts as an option at reduced cost.

optional equipment (extra cost)

Automatic Level Control
 Comfort Control Air Conditioner
 Controlled Differential
 Cruise Control
 De-Fogger, rear window
 Door Edge Guards
 Door Locks, power

Front Seat Adjustment (6-way), power
 Head Lamp Control, (Guide-Matic)
 License Frames
 Radio, AM
 Radio, AM-FM
 Seat Belts, rear
 Soft Ray Glass

Tilt and Telescope Steering Wheel
 Trunk Lock, remote-control
 Twilight Sentinel (automatic head lamp timer)
 Vent Windows, power
 Windows, power
 Whitewall Tires, 9.00 x 15 (set of five)

basic specifications

Wheelbase.....	129.5"
Length, over-all.....	224.0"
Width, over-all.....	79.9"
Height, over-all.....	54.6"
Engine Horsepower.....	340

interior dimensions

	front	rear
Head room.....	38.4"	37.6"
Shoulder room.....	62.0"	60.5"
Hip room.....	63.5"	55.0"
Leg room.....	41.0"	38.2"
Seat height.....	12.3"	14.5"

Cadillac
Calais Hardtop Sedan
nineteen hundred sixty-five

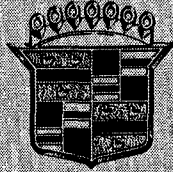

28

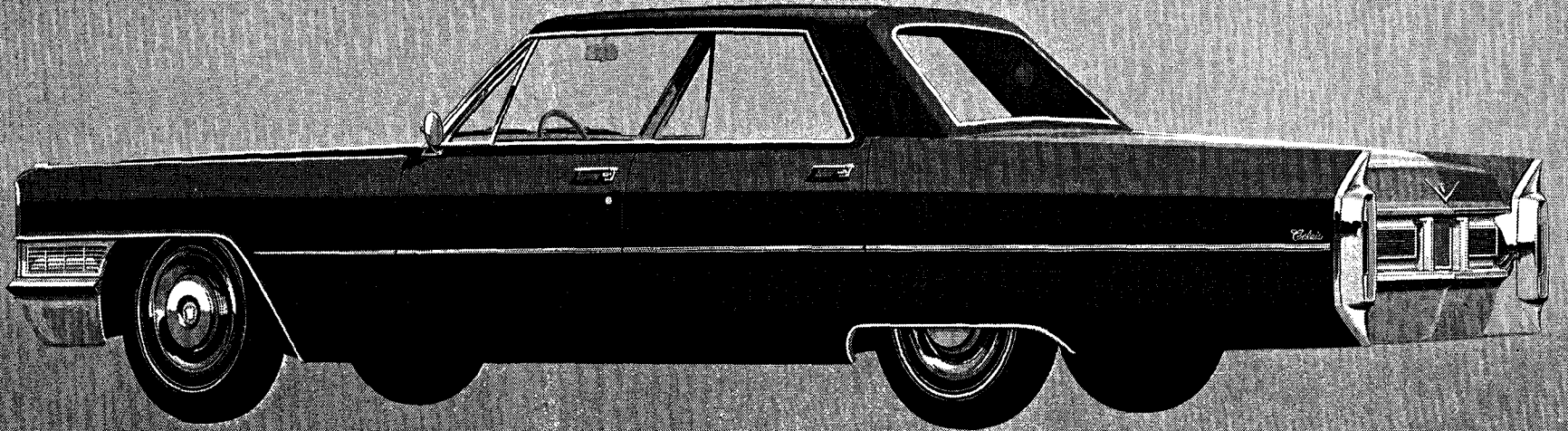

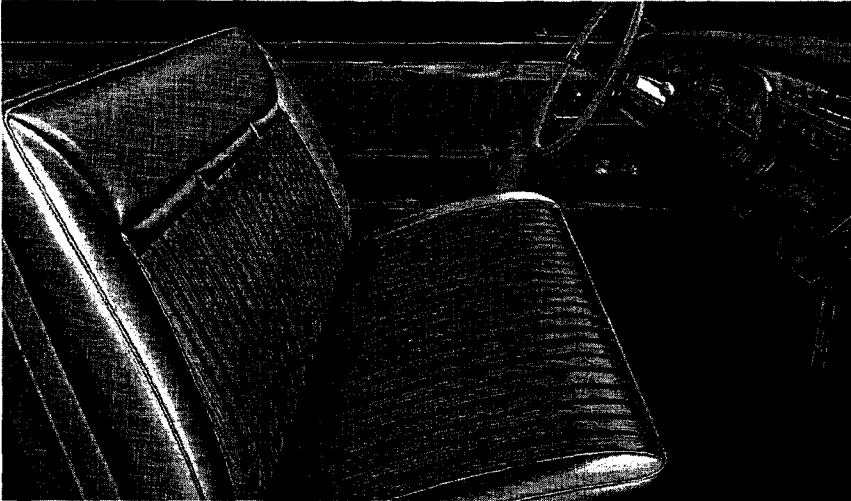
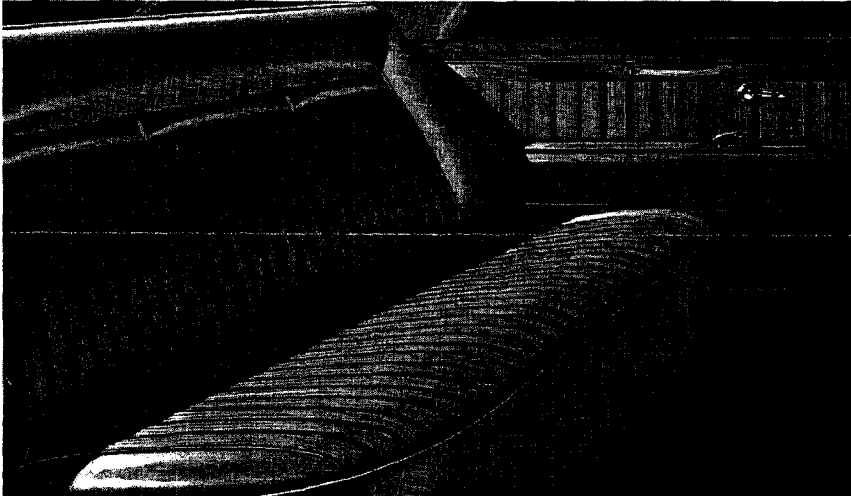
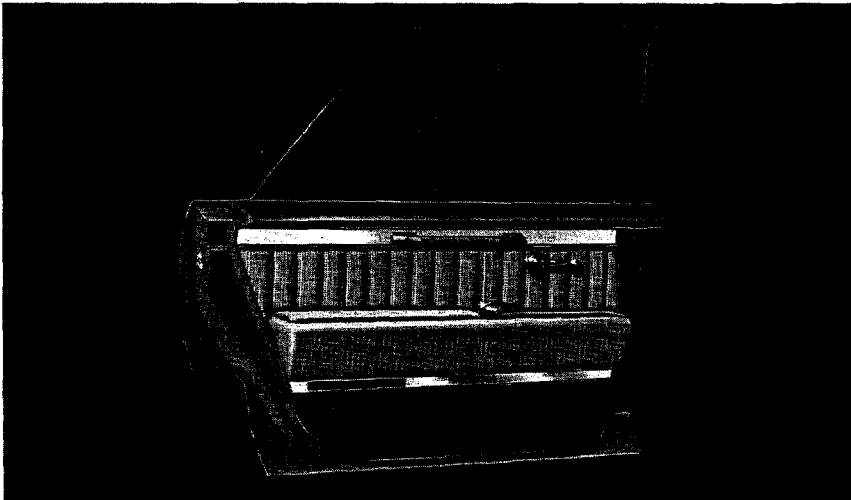
Front Compartment (Delmar Cloth)*Rear Compartment (Delmar Cloth)**Rear Door Panel*

upholstery selections

CODE

- 210. Black Basket Weave Delhi Cloth with White Coated Fabric bolsters and trim.
- 216. Gray Basket Weave Delhi Cloth with Gray Coated Fabric bolsters and trim.
- 220. Blue Pin Stripe Delmar Cloth with Blue Coated Fabric bolsters and trim.
- 226. Midnight Blue Basket Weave Delhi Cloth with Midnight Blue Coated Fabric bolsters and trim.
- 228. Turquoise Pin Stripe Delmar Cloth with Turquoise Coated Fabric bolsters and trim.
- 230. Green Pin Stripe Delmar Cloth with Green Coated Fabric bolsters and trim.
- 241. Sandalwood Basket Weave Delhi Cloth with Sandalwood Coated Fabric bolsters and trim.

↑
Calais Hardtop Sedan

standard equipment

Air Cleaner, dry-pack
 Armrest, center-rear
 Assist Handles (two)
 Cigarette Lighter, front
 Cigarette Lighters, rear (two)
 Clock, electric
 Heater-Defroster*
 Light, front ash receivers
 Lights, backup (dual)
 Lights, cornering

Lights, courtesy
 Lights, directional signal
 Light, glove box (automatic)
 Light, luggage compartment (automatic)
 Lights, reading
 Mirror, glareproof, rear-view, flip type, shatterproof
 Oil Filter, Full-Flow
 Outside Mirror, left side, remote-control
 Power Brakes

Power Steering
 Reflectors, door panel, safety warning
 Seat Belts, front*
 Turbo Hydra-Matic Transmission
 Visor Vanity Mirror, shatterproof
 Visors, dual sun
 Wheel Discs (set of four)
 Windshield Washer and Coordinator

*Available without heater-defroster or seat belts as an option at reduced cost.

optional equipment (extra cost)

Automatic Level Control
 Comfort Control Air Conditioner
 Controlled Differential
 Cruise Control
 De-Fogger, rear window
 Door Edge Guards
 Door Locks, power

Front Seat Adjustment (6-way), power
 Head Lamp Control, (Guide-Matic)
 License Frames
 Radio, AM
 Radio, AM-FM
 Trunk Lock, remote-control
 Seat Belts, rear

Soft Ray Glass
 Tilt and Telescope Steering Wheel
 Twilight Sentinel (automatic head lamp timer)
 Vent Windows, power
 Windows, power
 Whitewall Tires, 9.00 x 15 (set of five)

basic specifications

Wheelbase.....	129.5"
Length, over-all.....	224.0"
Width, over-all.....	79.9"
Height, over-all.....	54.5"
Engine Horsepower.....	340

interior dimensions

	front	rear
Head room.....	38.5"	37.6"
Shoulder room.....	61.8"	60.9"
Hip room.....	63.5"	62.7"
Leg room.....	41.1"	38.8"
Seat height.....	12.3"	14.6"

Cadillac
Calais Sedan
nineteen hundred sixty-five

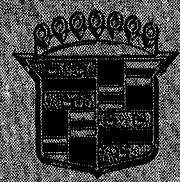

30

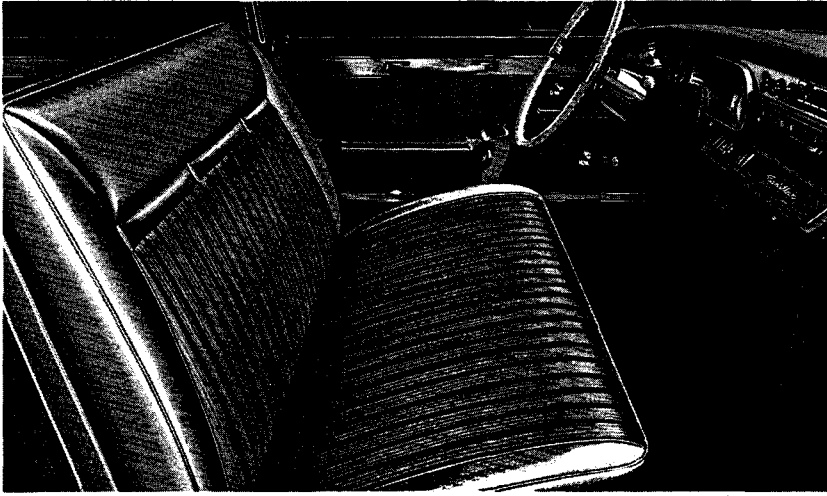
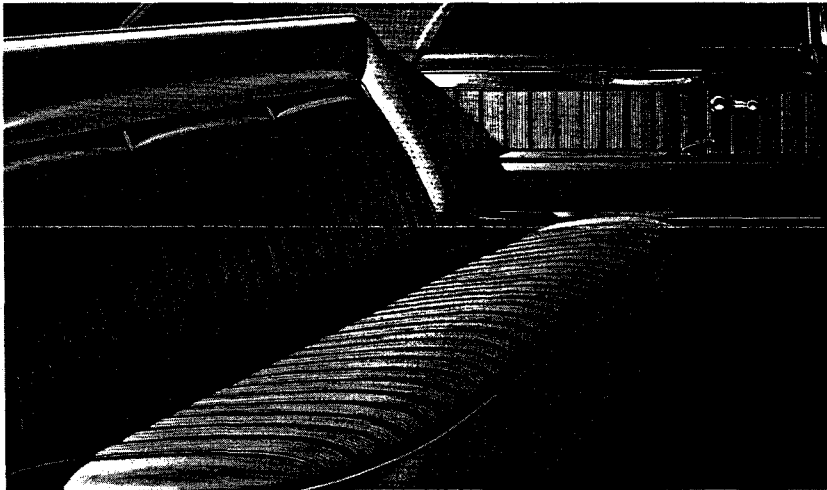
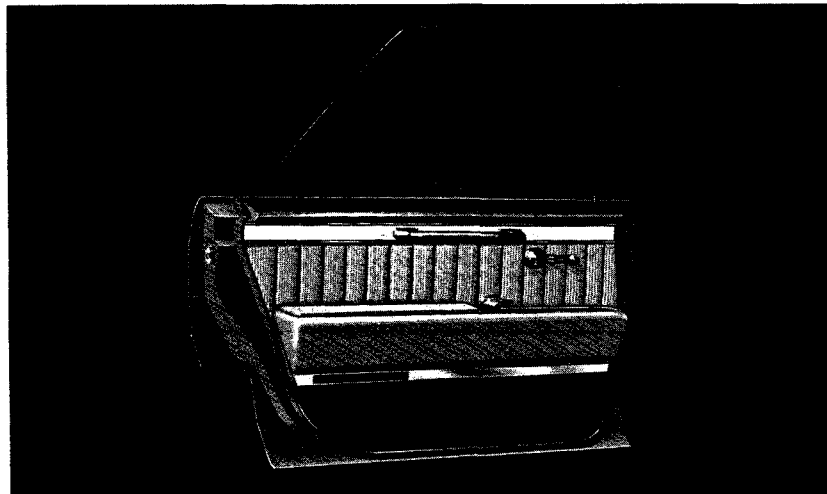

Front Compartment (Delmar Cloth)*Rear Compartment (Delmar Cloth)**Rear Door Panel*

upholstery selections

CODE

- 210. Black Basket Weave Delhi Cloth with White Coated Fabric bolsters and trim.
- 216. Gray Basket Weave Delhi Cloth with Gray Coated Fabric bolsters and trim.
- 220. Blue Pin Stripe Delmar Cloth with Blue Coated Fabric bolsters and trim.
- 226. Midnight Blue Basket Weave Delhi Cloth with Midnight Blue Coated Fabric bolsters and trim.
- 228. Turquoise Pin Stripe Delmar Cloth with Turquoise Coated Fabric bolsters and trim.
- 230. Green Pin Stripe Delmar Cloth with Green Coated Fabric bolsters and trim.
- 241. Sandalwood Basket Weave Delhi Cloth with Sandalwood Coated Fabric bolsters and trim.

↑
Calais Sedan

standard equipment

Air Cleaner, dry-pack
 Armrest, center-rear
 Assist Handles (two)
 Cigarette Lighter, front
 Cigarette Lighters, rear (two)
 Clock, electric
 Heater-Defroster*
 Light, front ash receivers
 Lights, backup (dual)
 Lights, cornering

Lights, courtesy
 Lights, directional signal
 Light, glove box (automatic)
 Light, luggage compartment (automatic)
 Lights, reading
 Mirror, glareproof, rear-view, flip type, shatterproof
 Oil Filter, Full-Flow
 Outside Mirror, left side, remote-control
 Power Brakes

Power Steering
 Reflectors, door panel, safety warning
 Seat Belts, front*
 Turbo Hydra-Matic Transmission
 Visor Vanity Mirror, shatterproof
 Visors, dual sun
 Wheel Discs (set of four)
 Windshield Washer and Coordinator
 *Available without heater-defroster or seat belts as an option at reduced cost.

optional equipment (extra cost)

Automatic Level Control
 Comfort Control Air Conditioner
 Controlled Differential
 Cruise Control
 De-Fogger, rear window
 Door Edge Guards
 Door Locks, power

Front Seat Adjustment (6-way), power
 Head Lamp Control, (Guide-Matic)
 License Frames
 Radio, AM
 Radio, AM-FM
 Seat Belts, rear
 Soft Ray Glass

Tilt and Telescope Steering Wheel
 Trunk Lock, remote-control
 Twilight Sentinel (automatic head lamp timer)
 Vent Windows, power
 Windows, power
 Whitewall Tires, 9.00 x 15 (set of five)

basic specifications

Wheelbase.....	129.5"
Length, over-all.....	224.0"
Width, over-all.....	79.9"
Height, over-all.....	55.6"
Engine Horsepower.....	340

interior dimensions

	front	rear
Head room.....	39.5"	38.4"
Shoulder room.....	61.8"	60.9"
Hip room.....	63.5"	62.6"
Leg room.....	41.1"	40.9"
Seat height.....	12.3"	14.6"

**Cadillac
De Ville Convertible**
nineteen hundred sixty-five

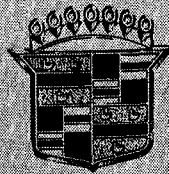

Base 5590

32

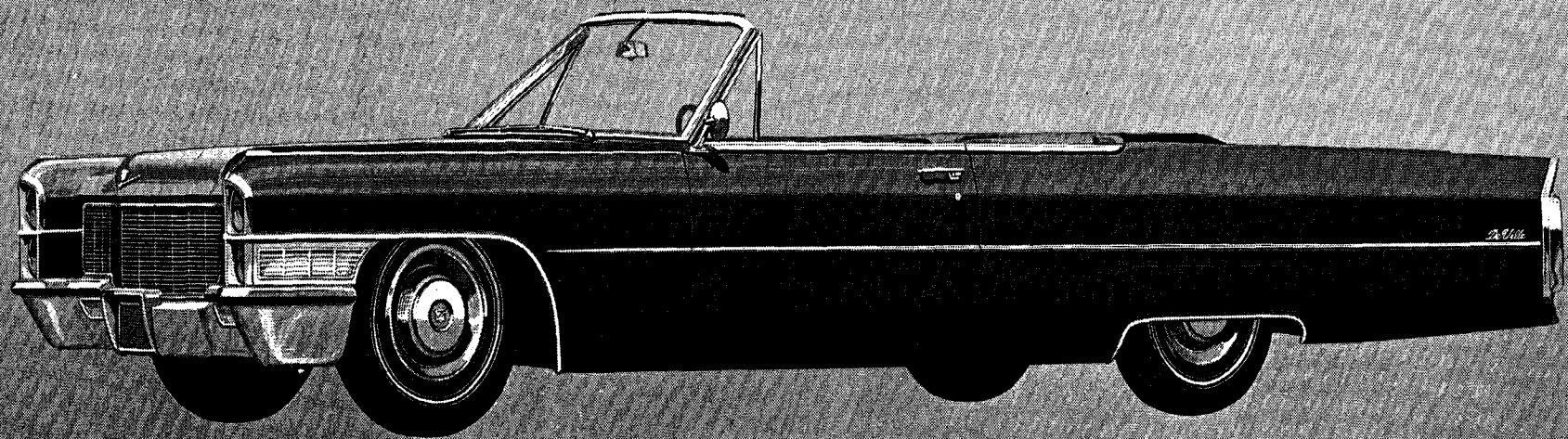

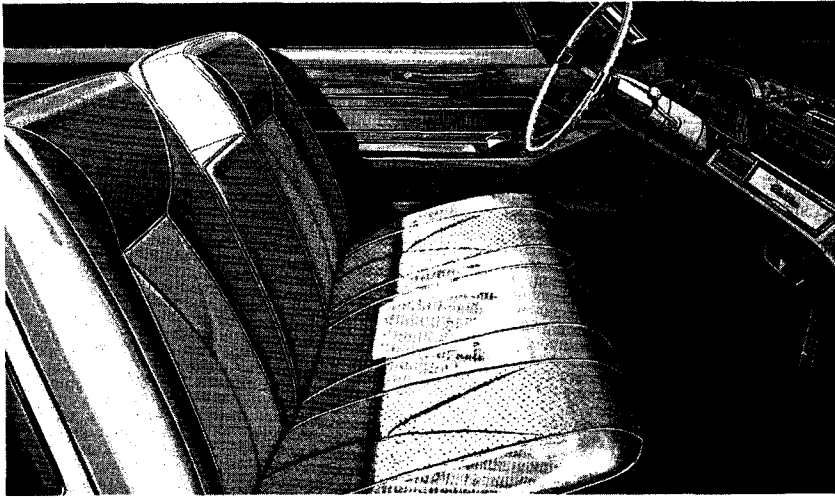
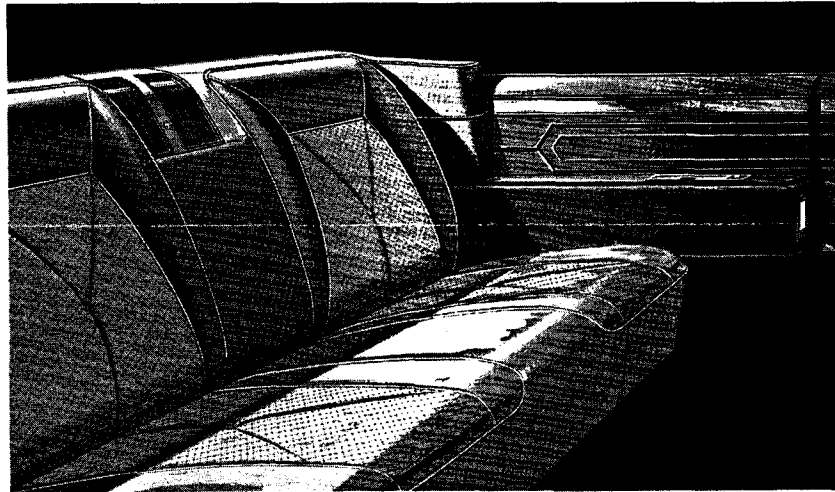
Front Compartment*Rear Compartment**Front Compartment Bucket Seats*

upholstery selections

(Perforated leather seat and seat-back inserts) (Carpeting in shade of upholstery color except as noted)

CODE*

- 351. Black Natural Finish Leather.
- 352. White Natural Finish Leather (Black carpet).
- 353. White Natural Finish Leather (Blue carpet).
- 354. White Natural Finish Leather (Red carpet).
- 355. White Natural Finish Leather (Turquoise carpet).
- 360. Blue Antique Finish Leather.
- 370. Green Antique Finish Leather.
- 381. Sandalwood Antique Finish Leather.
- 383. Tan Antique Finish Leather.
- 386. Bronze Antique Finish Leather.
- 388. Red Antique Finish Leather.

*Add B after code number when ordering bucket seats (extra cost).

top options

- 1. White
- 2. Black
- 3. Blue
- 4. Green
- 6. Sandalwood

↑
De Ville Convertible

standard equipment

Air Cleaner, dry-pack
 Armrest, center-front
 Cigarette Lighter, front
 Cigarette Lighters, rear (two)
 Clock, electric
 Front Seat Adjustment (horizontal),
 power
 Heater-Defroster*
 Light, front ash receivers
 Lights, backup (dual)
 Lights, cornering

Lights, courtesy
 Lights, directional signal
 Light, glove box (automatic)
 Light, luggage compartment (automatic)
 Mirror, glareproof, rear-view, flip type,
 shatterproof
 Oil Filter, Full-Flow
 Outside Mirror, left side, remote-control
 Power Brakes
 Power Steering

Red Lens, door panel, illuminated,
 safety warning
 Seat Belts, front*
 Turbo Hydra-Matic Transmission
 Visor Vanity Mirror, shatterproof
 Visors, dual sun
 Wheel Discs (set of four)
 Windows, power
 Windshield Washer and Coordinator
 *Available without heater-defroster or seat belts as an option at
 reduced cost.

optional equipment (extra cost)

Automatic Level Control
 Bucket Seats, power, front
 Comfort Control Air Conditioner
 Controlled Differential
 Cruise Control
 Door Edge Guards
 Door Locks, power

Front Seat Adjustment (vertical and
 angle), power**
 Head Lamp Control, (Guide-Matic)
 License Frames
 Radio, AM
 Radio, AM-FM
 Seat Belts, rear

Soft Ray Glass
 Tilt and Telescope Steering Wheel
 Trunk Lock, remote-control
 Twilight Sentinel (automatic head lamp
 timer)
 Vent Windows, power
 Whitewall Tires, 9.00 x 15 (set of five)
 **Angle adjustment, driver's seat only on bucket seats.

basic specifications

Wheelbase.....	129.5"
Length, over-all.....	224.0"
Width, over-all.....	79.9"
Height, over-all.....	54.6"
Engine Horsepower.....	340

interior dimensions

	front	rear
Head room.....	38.6"	37.5"
Shoulder room.....	62.0"	52.5"
Hip room.....	63.5"	55.0"
Leg room.....	41.0"	38.2"
Seat height.....	12.3"	14.6"

Base 5386.00

Cadillac
Coupe de Ville
nineteen hundred sixty-five

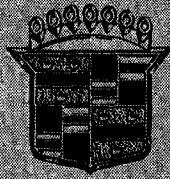

34

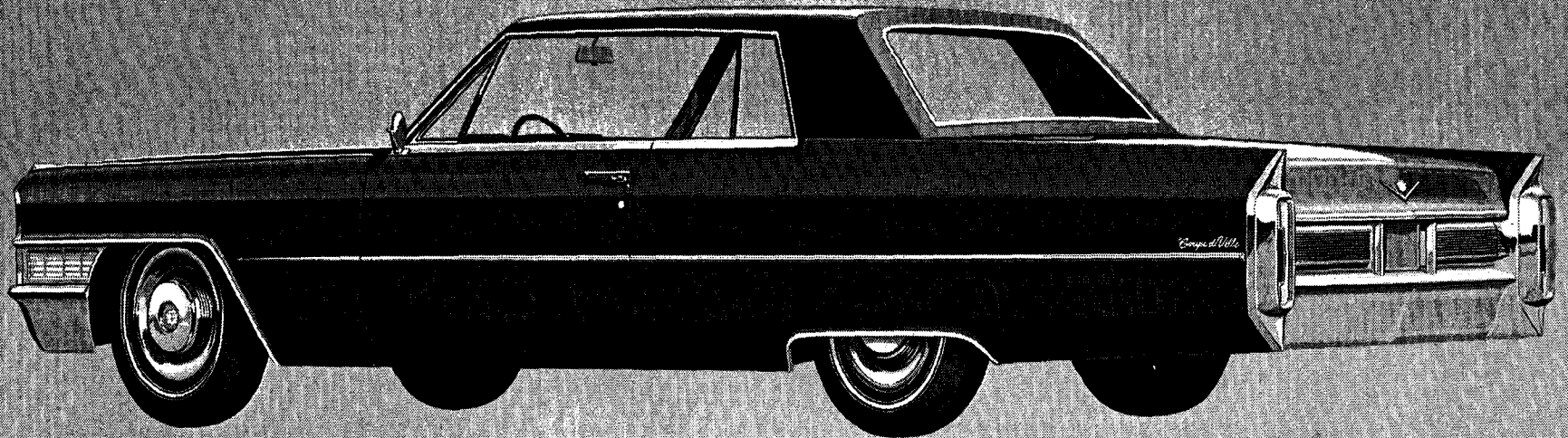

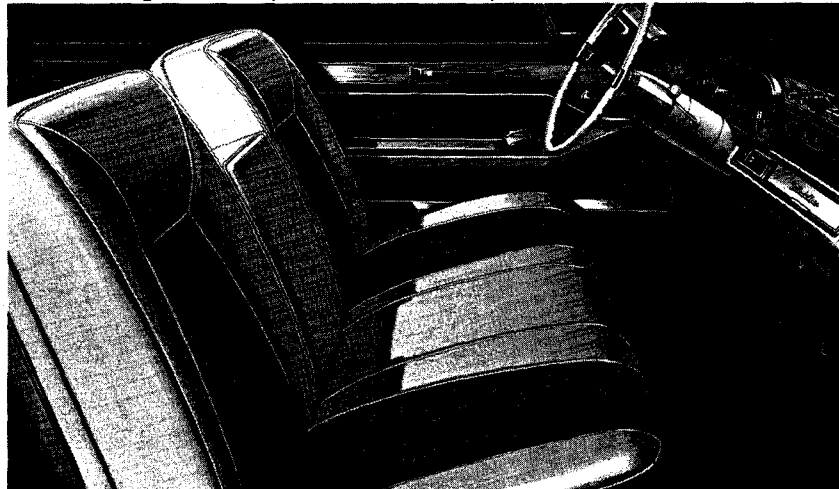
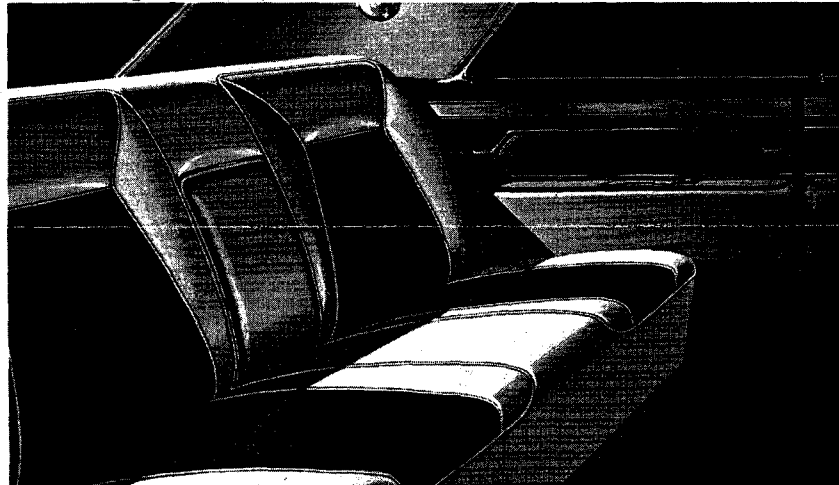
Front Compartment (Drummond Cloth)*Rear Compartment (Drummond Cloth)**Front Compartment Bucket Seats (Leather)*

upholstery selections

(Fabric and leather)

CODE

- 310. Black Honeycomb Weave Drummond Cloth with White Natural Finish Leather bolsters.
- 319. Dark Gray Random Weave Delta Cloth with Gray Antique Finish Leather bolsters.
- 320. Blue Honeycomb Weave Drummond Cloth with Blue Antique Finish Leather bolsters.
- 326. Midnight Blue Random Weave Delta Cloth with Midnight Blue Antique Finish Leather bolsters.
- 328. Turquoise Random Weave Delta Cloth with Turquoise Antique Finish Leather bolsters.
- 330. Green Honeycomb Weave Drummond Cloth with Green Antique Finish Leather bolsters.
- 341. Sandalwood Random Weave Delta Cloth with Sandalwood Antique Finish Leather bolsters.
- 346. Bronze Honeycomb Weave Drummond Cloth with Bronze Antique Finish Leather bolsters.

Leather*, optional at extra cost. Perforated seat and seat-back inserts.

- 351. Black Natural Finish Leather.
- 352. White Natural Finish Leather (Black carpet).
- 353. White Natural Finish Leather (Blue carpet).
- 354. White Natural Finish Leather (Red carpet).
- 355. White Natural Finish Leather (Turquoise carpet).
- 381. Sandalwood Antique Finish Leather.
- 388. Red Antique Finish Leather.

*Add B after code number when ordering bucket seats (extra cost).

padded vinyl covered top options (extra cost)

- 61. White
- 62. Black
- 63. Blue
- 66. Sandalwood



Coupe de Ville

standard equipment

Air Cleaner, dry-pack
 Armrest, center, front and rear
 Cigarette Lighter, front
 Cigarette Lighters, rear (two)
 Clock, electric
 Front Seat Adjustment (horizontal), power
 Heater-Defroster*
 Light, front ash receivers
 Lights, backup (dual)
 Lights, cornering

Lights, courtesy
 Lights, directional signal
 Light, glove box (automatic)
 Light, luggage compartment (automatic)
 Lights, reading
 Mirror, glareproof, rear-view, flip type, shatterproof
 Oil Filter, Full-Flow
 Outside Mirror, left side, remote-control
 Power Brakes
 Power Steering

Red Lens, door panel, illuminated, safety warning
 Seat Belts, front*
 Turbo Hydra-Matic Transmission
 Visor Vanity Mirror, shatterproof
 Visors, dual sun
 Wheel Discs (set of four)
 Windows, power
 Windshield Washer and Coordinator

*Available without heater-defroster or seat belts as an option at reduced cost.

optional equipment (extra cost)

Automatic Level Control
 Bucket or Bench Seats, leather
 Comfort Control Air Conditioner
 Controlled Differential
 Cruise Control
 De-Fogger, rear window
 Door Edge Guards
 Door Locks, power

Front Seat Adjustment (vertical and angle), power**
 Head Lamp Control, (Guide-Matic)
 License Frames
 Padded Vinyl Roof
 Radio, AM
 Radio, AM-FM
 Seat Belts, rear

Soft Ray Glass
 Tilt and Telescope Steering Wheel
 Trunk Lock, remote-control
 Twilight Sentinel (automatic head lamp timer)
 Vent Windows, power
 Whitewall Tires, 9.00 x 15 (set of five)

**Angle adjustment, driver's seat only on bucket seats.

basic specifications

Wheelbase.....	129.5"
Length, over-all.....	224.0"
Width, over-all.....	79.9"
Height, over-all.....	54.6"
Engine Horsepower.....	340

interior dimensions

	front	rear
Head room.....	38.4"	37.5"
Shoulder room.....	62.0"	60.5"
Hip room.....	63.5"	55.0"
Leg room.....	41.0"	38.7"
Seat height.....	12.3"	14.6"

Cadillac
Hardtop Sedan de Ville
nineteen hundred sixty-five

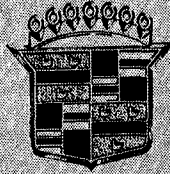

36

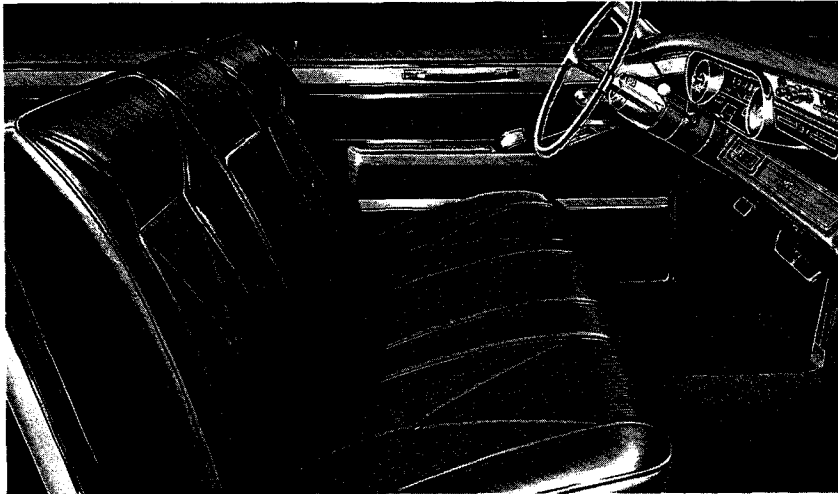

Front Compartment (Delta Cloth)*Front Compartment (Leather)**Front Compartment Bucket Seats (Leather)*

upholstery selections

(Fabric and leather)

CODE

- 310. Black Honeycomb Weave Drummond Cloth with White Natural Finish Leather bolsters.
- 319. Dark Gray Random Weave Delta Cloth with Gray Antique Finish Leather bolsters.
- 320. Blue Honeycomb Weave Drummond Cloth with Blue Antique Finish Leather bolsters.
- 326. Midnight Blue Random Weave Delta Cloth with Midnight Blue Antique Finish Leather bolsters.
- 328. Turquoise Random Weave Delta Cloth with Turquoise Antique Finish Leather bolsters.
- 330. Green Honeycomb Weave Drummond Cloth with Green Antique Finish Leather bolsters.
- 341. Sandalwood Random Weave Delta Cloth with Sandalwood Antique Finish Leather bolsters.
- 346. Bronze Honeycomb Weave Drummond Cloth with Bronze Antique Finish Leather bolsters.

Leather*, optional at extra cost. Perforated seat and seat-back inserts.

- 351. Black Natural Finish Leather.
- 352. White Natural Finish Leather (Black carpet).
- 353. White Natural Finish Leather (Blue carpet).
- 354. White Natural Finish Leather (Red carpet).
- 355. White Natural Finish Leather (Turquoise carpet).
- 381. Sandalwood Antique Finish Leather.
- 388. Red Antique Finish Leather.

*Add B after code number when ordering bucket seats (extra cost).

padding vinyl covered top options (extra cost)

- 61. White
- 62. Black
- 63. Blue
- 66. Sandalwood

↑
Hardtop Sedan de Ville

standard equipment

Air Cleaner, dry-pack
 Armrest, center, front and rear
 Assist Handles (two)
 Cigarette Lighter, front
 Cigarette Lighters, rear (two)
 Clock, electric
 Front Seat Adjustment (horizontal), power
 Heater-Defroster*
 Light, front ash receivers
 Lights, backup (dual)
 Lights, cornering

Lights, courtesy
 Lights, directional signal
 Light, glove box (automatic)
 Light, luggage compartment (automatic)
 Lights, reading
 Mirror, glareproof, rear-view, flip type, shatterproof
 Oil Filter, Full-Flow
 Outside Mirror, left side, remote-control
 Power Brakes
 Power Steering

Red Lens, door panel, illuminated, safety warning
 Seat Belts, front*
 Turbo Hydra-Matic Transmission
 Visor Vanity Mirror, shatterproof
 Visors, dual sun
 Wheel Discs (set of four)
 Windows, power
 Windshield Washer and Coordinator
 *Available without heater-defroster or seat belts as an option at reduced cost.

optional equipment (extra cost)

Automatic Level Control
 Bucket or Bench Seats, leather
 Comfort Control Air Conditioner
 Controlled Differential
 Cruise Control
 De-Fogger, rear window
 Door Edge Guards
 Door Locks, power

Front Seat Adjustment (vertical and angle), power**
 Head Lamp Control, (Guide-Matic)
 License Frames
 Padded Vinyl Roof
 Radio, AM
 Radio, AM-FM
 Seat Belts, rear

Soft Ray Glass
 Tilt and Telescope Steering Wheel
 Trunk Lock, remote-control
 Twilight Sentinel (automatic head lamp timer)
 Vent Windows, power
 Whitewall Tires, 9.00 x 15 (set of five)
 **Angle adjustment, driver's seat only on bucket seats.

basic specifications

Wheelbase.....	129.5"
Length, over-all.....	224.0"
Width, over-all.....	79.9"
Height, over-all.....	54.5"
Engine Horsepower.....	340

interior dimensions

	front	rear
Head room.....	38.5"	37.5"
Shoulder room.....	61.8"	60.9"
Hip room.....	63.5"	62.7"
Leg room.....	41.1"	39.5"
Seat height.....	12.3"	14.5"

Cadillac
Sedan de Ville
nineteen hundred sixty-five

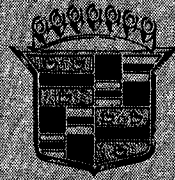

38

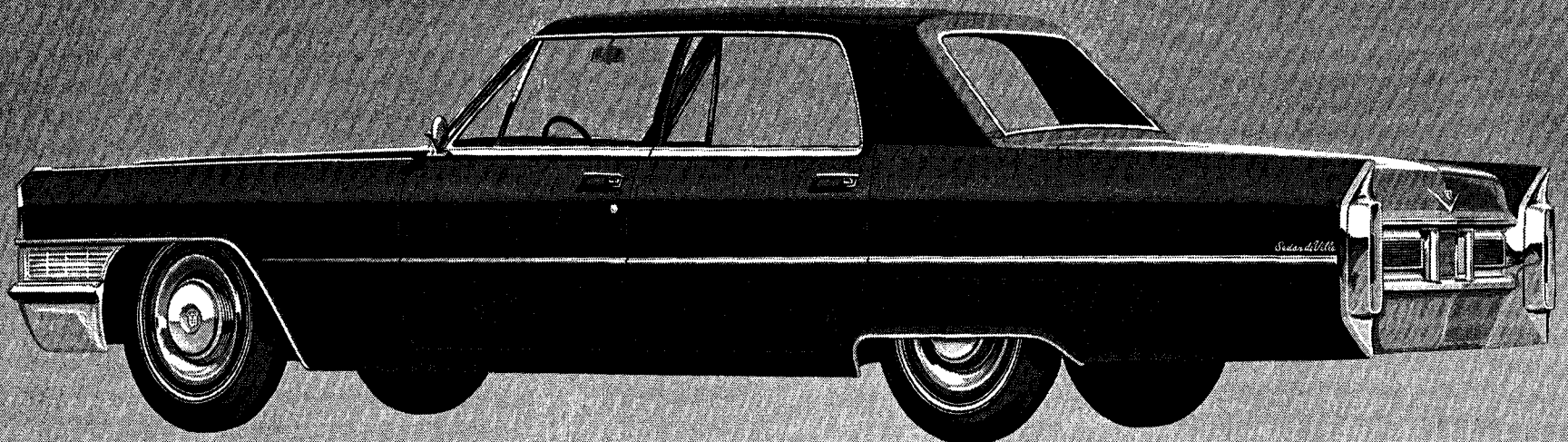

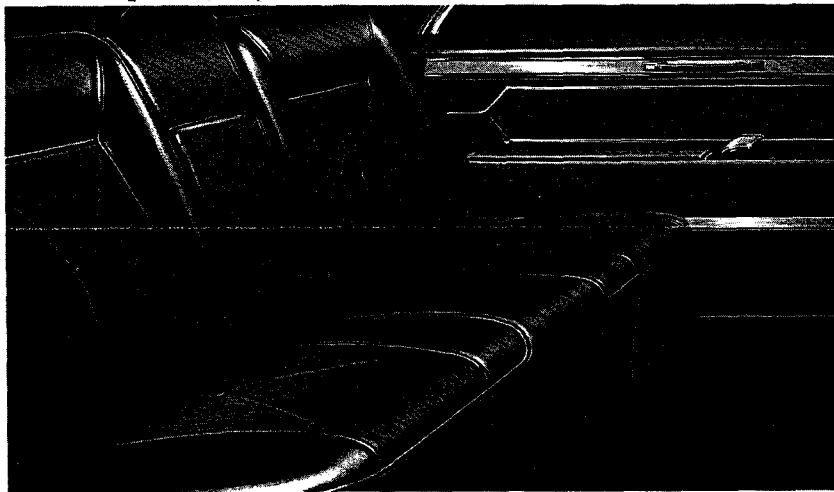
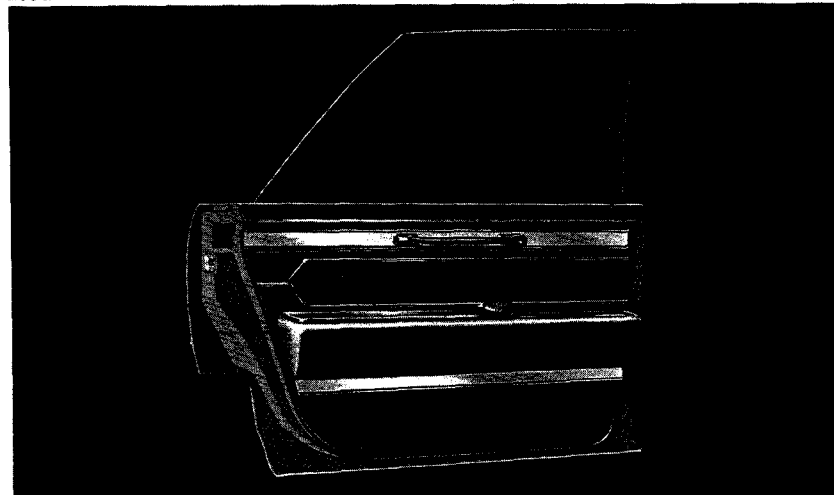
Front Compartment (Delta Cloth)*Rear Compartment (Delta Cloth)**Rear Door Panel*

upholstery selections

(Fabric and leather)

CODE

- 310. Black Honeycomb Weave Drummond Cloth with White Natural Finish Leather bolsters.
 - 319. Dark Gray Random Weave Delta Cloth with Gray Antique Finish Leather bolsters.
 - 320. Blue Honeycomb Weave Drummond Cloth with Blue Antique Finish Leather bolsters.
 - 326. Midnight Blue Random Weave Delta Cloth with Midnight Blue Antique Finish Leather bolsters.
 - 328. Turquoise Random Weave Delta Cloth with Turquoise Antique Finish Leather bolsters.
 - 330. Green Honeycomb Weave Drummond Cloth with Green Antique Finish Leather bolsters.
 - 341. Sandalwood Random Weave Delta Cloth with Sandalwood Antique Finish Leather bolsters.
 - 346. Bronze Honeycomb Weave Drummond Cloth with Bronze Antique Finish Leather bolsters.
- Leather, optional at extra cost. Perforated seat and seat-back inserts.
- 351. Black Natural Finish Leather.
 - 352. White Natural Finish Leather (Black carpet).
 - 353. White Natural Finish Leather (Blue carpet).
 - 354. White Natural Finish Leather (Red carpet).
 - 355. White Natural Finish Leather (Turquoise carpet).
 - 381. Sandalwood Antique Finish Leather.
 - 388. Red Antique Finish Leather.

padding vinyl covered top options (extra cost)

- 61. White
- 62. Black
- 63. Blue
- 66. Sandalwood



Sedan de Ville

standard equipment

Air Cleaner, dry-pack
 Armrest, center, front and rear
 Assist Handles (two)
 Cigarette Lighter, front
 Cigarette Lighters, rear (two)
 Clock, electric
 Front Seat Adjustment (horizontal), power
 Heater-Defroster*
 Light, front ash receivers
 Lights, backup (dual)
 Lights, cornering

Lights, courtesy
 Lights, directional signal
 Light, glove box (automatic)
 Light, luggage compartment (automatic)
 Lights, reading
 Mirror, glareproof, rear-view, flip type, shatterproof
 Oil Filter, Full-Flow
 Outside Mirror, left side, remote-control
 Power Brakes
 Power Steering

Red Lens, door panel, illuminated, safety warning
 Seat Belts, front*
 Turbo Hydra-Matic Transmission
 Visor Vanity Mirror, shatterproof
 Visors, dual sun
 Wheel Discs (set of four)
 Windows, power
 Windshield Washer and Coordinator

*Available without heater-defroster or seat belts as an option at reduced cost.

39

optional equipment (extra cost)

Automatic Level Control
 Bench Seats, leather
 Comfort Control Air Conditioner
 Controlled Differential
 Cruise Control
 De-Fogger, rear window
 Door Edge Guards

Door Locks, power
 Front Seat Adjustment (vertical and angle), power
 Head Lamp Control, (Guide-Matic)
 License Frames
 Padded Vinyl Roof
 Radio, AM
 Radio, AM-FM

Seat Belts, rear
 Soft Ray Glass
 Tilt and Telescope Steering Wheel
 Trunk Lock, remote-control
 Twilight Sentinel (automatic head lamp timer)
 Vent Windows, power
 Whitewall Tires, 9.00 x 15 (set of five)

basic specifications

Wheelbase.....	129.5"
Length, over-all.....	224.0"
Width, over-all.....	79.9"
Height, over-all.....	55.6"
Engine Horsepower.....	340

interior dimensions

	front	rear
Head room.....	39.5"	38.4"
Shoulder room.....	61.8"	60.9"
Hip room.....	63.5"	62.6"
Leg room.....	41.1"	41.0"
Seat height.....	12.3"	14.5"

**Fleetwood
Eldorado Convertible**
nineteen hundred sixty-five

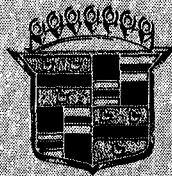

40

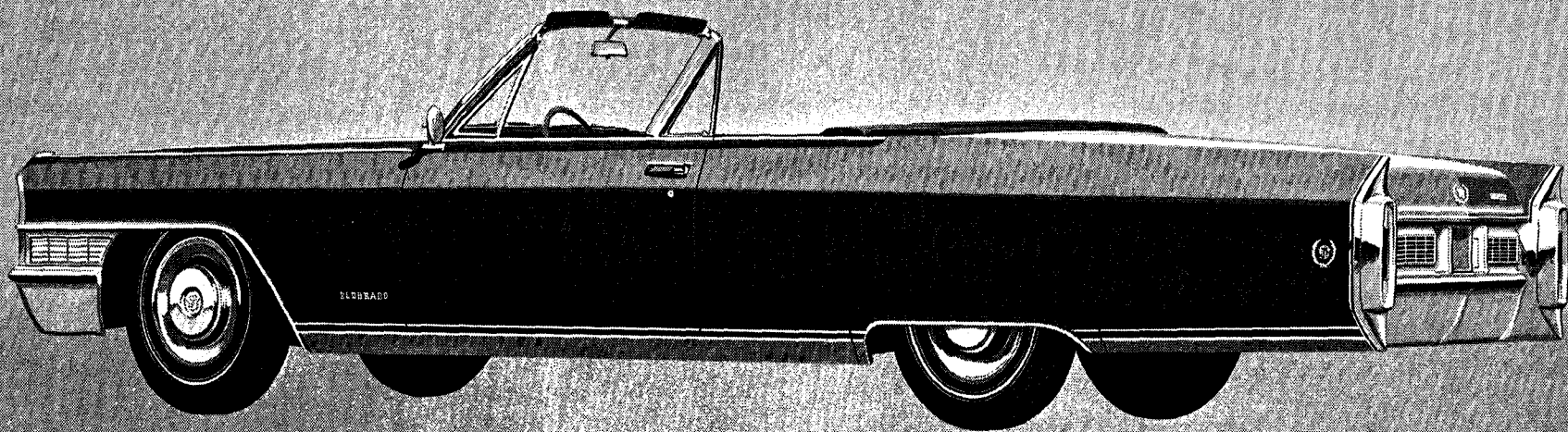

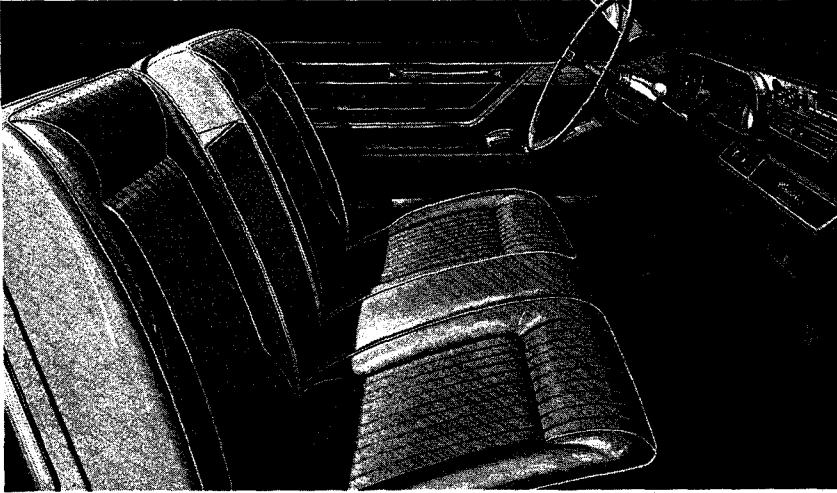
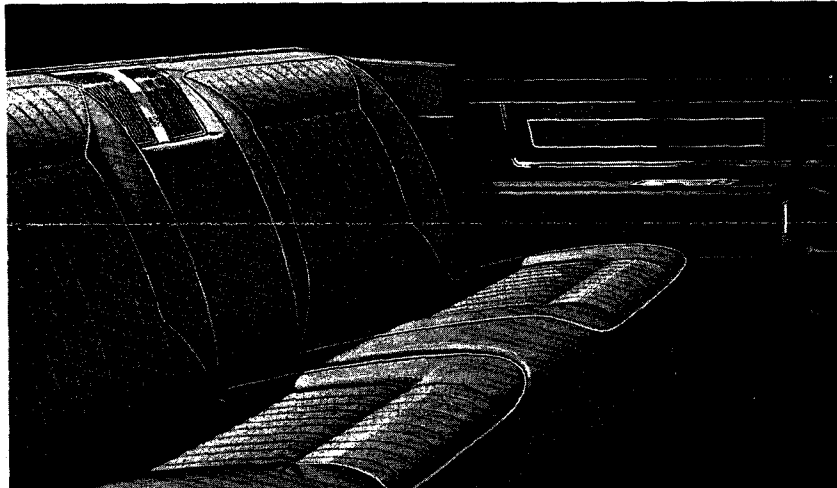
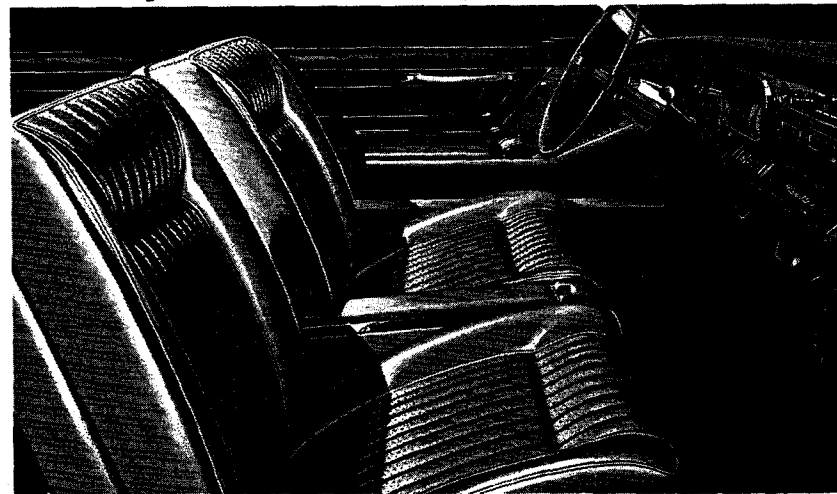
Front Compartment*Rear Compartment**Front Compartment Bucket Seats*

upholstery selections

(Perforated seat and seat-back inserts)

(Carpeting in shade of upholstery color except as noted)

CODE*

- 451. Black Natural Finish Leather.
- 452. White Natural Finish Leather (Black carpet).
- 454. White Natural Finish Leather (Red carpet).
- 461. Gray-Blue Antique Finish Leather.
- 476. Blue-Green Antique Finish Leather.
- 481. Sandalwood Antique Finish Leather.
- 483. Tan Antique Finish Leather.
- 488. Red Antique Finish Leather.

*Add B after code number when ordering bucket seats.

top options

1. White
2. Black
5. Gray-Blue
6. Sandalwood

↑
Fleetwood Eldorado Convertible

standard equipment

Air Cleaner, dry-pack
 Armrest, center-front
 Automatic Level Control
 Bucket Seats, front (optional at no extra cost)
 Cigarette Lighter, front
 Cigarette Lighters, rear (two)
 Clock, electric
 Front Seat Adjustment (6-way)*
 Heater-Defroster**
 Light, front ash receivers
 Lights, backup (dual)
 Lights, cornering
 Lights, courtesy

Lights, directional signal
 Light, glove box (automatic)
 Light, luggage compartment (automatic)
 Oil Filter, Full-Flow
 Outside Mirror, left side, remote-control
 Power Brakes
 Power Steering
 Rear-view Mirror, 3-way, Soft Ray, shatterproof
 Red Lens, illuminated, safety warning on doors
 Seat Belts, front**

Spare Tire Cover
 Turbo Hydra-Matic Transmission
 Vent Windows, power
 Visor Vanity Mirror, shatterproof
 Visors, dual sun
 Wheel Discs (set of four)
 Whitewall Tires, 9.00 x 15 (set of five)
 Windows, power
 Windshield Washer and Coordinator

*Fore-and-aft adjustment only (and angle on driver's side) when bucket seats are selected.

**Available without heater-defroster or seat belts as an option at reduced cost.

optional equipment (extra cost)

Comfort Control Air Conditioner
 Controlled Differential
 Cruise Control
 Door Edge Guards
 Door Locks, power
 Head Lamp Control, (Guide-Matic)

License Frames
 Radio, AM
 Radio, AM-FM
 Trunk Lock, remote-control
 Seat Belts, rear
 Soft Ray Glass

Tilt and Telescope Steering Wheel
 Twilight Sentinel (automatic head lamp timer)

basic specifications

Wheelbase.....	129.5"
Length, over-all.....	224.0"
Width, over-all.....	79.9"
Height, over-all.....	54.6"
Engine Horsepower.....	340

interior dimensions

	front	rear
Head room.....	39.1"	37.5"
Shoulder room.....	62.0"	52.5"
Hip room.....	63.5"	55.0"
Leg room.....	41.0"	37.6"
Seat height.....	11.9"	14.4"

**Fleetwood
Sixty Special Sedan**
nineteen hundred sixty-five

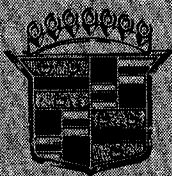

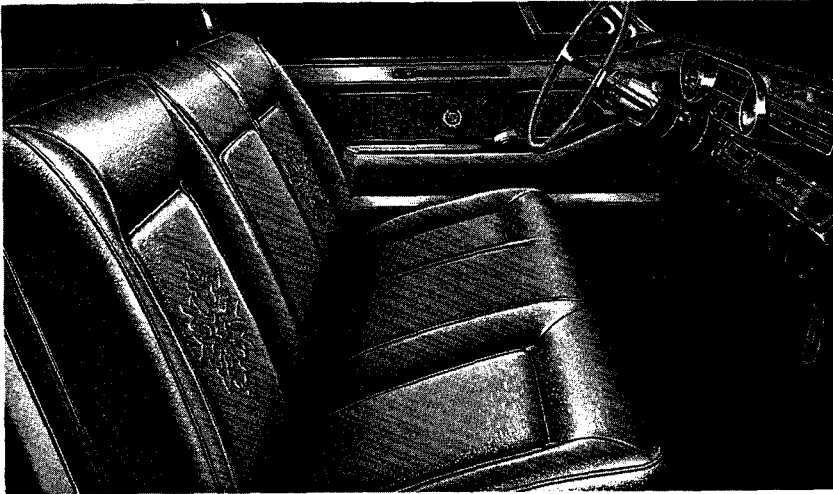
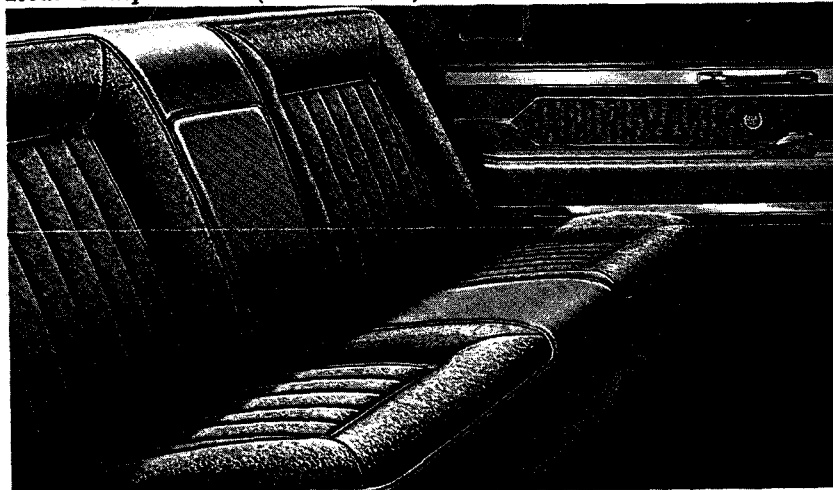
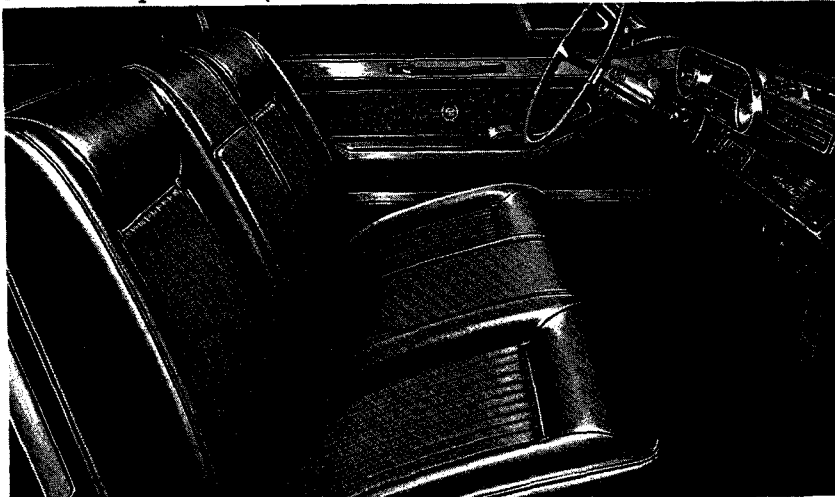
Front Compartment (Danforth Cloth)*Rear Compartment (Devon Cloth)**Front Compartment (Leather)*

upholstery selections

(Fabric)

CODE

- 018. Gray Danforth Cloth with embroidered seat-back inserts.
- 021. Blue Danforth Cloth with embroidered seat-back inserts.
- 026. Midnight Blue Danforth Cloth with embroidered seat-back inserts.
- 030. Green Danforth Cloth with embroidered seat-back inserts.
- 044. Beige Danforth Cloth with embroidered seat-back inserts.
(Fabric and leather)
- 011. Black Sculptured Devon Cloth with Black Natural Finish Leather bolsters.
- 016. Gray Sculptured Devon Cloth with Gray Antique Finish Leather bolsters.
- 020. Blue Sculptured Devon Cloth with Blue Antique Leather bolsters.
- 028. Turquoise Sculptured Devon Cloth with Turquoise Antique Finish Leather bolsters.
- 041. Sandalwood Sculptured Devon Cloth with Sandalwood Antique Finish Leather bolsters.
(Leather, optional at extra cost, perforated seat and seat-back inserts)
(Carpeting in shade of upholstery color except as noted)
- 051. Black Natural Finish Leather.
- 052. White Natural Finish Leather (Black Carpet).
- 053. White Natural Finish Leather (Blue carpet).
- 054. White Natural Finish Leather (Red carpet).
- 055. White Natural Finish Leather (Turquoise carpet).
- 081. Sandalwood Antique Finish Leather.
- 088. Red Antique Finish Leather.

↑
Fleetwood Sixty Special Sedan

standard equipment

Air Cleaner, dry-pack
 Armrest, center, front and rear
 Assist Handles (two)
 Automatic Level Control
 Cigarette Lighter, front
 Cigarette Lighters, rear (two)
 Clock, electric
 Front Seat Adjustment (2-way),
 power
 Heater-Defroster*
 Light, front ash receivers
 Lights, backup (dual)
 Lights, cornering

Lights, courtesy
 Lights, directional signal
 Light, glove box (automatic)
 Light, luggage compartment (automatic)
 Lights, reading
 Oil Filter, Full-Flow
 Outside Mirror, left side, remote-control
 Power Brakes
 Power Steering
 Rear-view Mirror, 3-way, Soft Ray,
 shatterproof
 Red Lens, illuminated, safety warning
 on doors

Seat Belts, front*
 Spare Tire Cover
 Turbo Hydra-Matic Transmission
 Vent Windows, power
 Visor Vanity Mirror, shatterproof
 Visors, dual sun
 Wheel Discs (set of four)
 Windows, power
 Windshield Washer and Coordinator

*Available without heater-defroster or seat belts as an option at reduced cost.

optional equipment (extra cost)

Bench Seats, leather
 Comfort Control Air Conditioner
 Controlled Differential
 Cruise Control
 De-Fogger, rear window
 Door Edge Guards
 Door Locks, power

Front Seat Adjustment (6-way)
 Head Lamp Control, (Guide-Matic)
 License Frames
 Padded Vinyl Roof (See Brougham
 Option next page)
 Radio, AM
 Radio, AM-FM

Seat Belts, rear
 Soft Ray Glass
 Tilt and Telescope Steering Wheel
 Trunk Lock, remote-control
 Twilight Sentinel (automatic head lamp
 timer)
 Whitewall Tires, 9.00 x 15 (set of five)

basic specifications

Wheelbase.....	133.0"
Length, over-all.....	227.5"
Width, over-all.....	79.9"
Height, over-all.....	55.9"
Engine Horsepower.....	340

interior dimensions

	front	rear
Head room.....	39.5"	38.2"
Shoulder room.....	61.9"	60.8"
Hip room.....	63.5"	62.4"
Leg room.....	41.1"	39.6"
Seat height.....	12.3"	14.0"

**Fleetwood
Sixty Special Sedan
Brougham Option**
nineteen hundred sixty-five

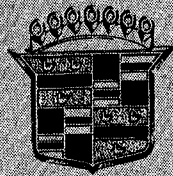

44



Brougham Option for the Fleetwood Sixty Special Sedan includes all of the luxuries, conveniences and power assists on the previous page plus special padded, cross-grained vinyl roof cover set off by a slim twin-bead and vinyl color molding around the entire roof area. Insignia on rear window pillars features Brougham name in chromed script.

Padded Top Options

61. White

62. Black

63. Blue

66. Sandalwood

**Fleetwood
Seventy-Five Sedan
and Limousine**

nineteen hundred sixty-five

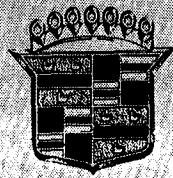

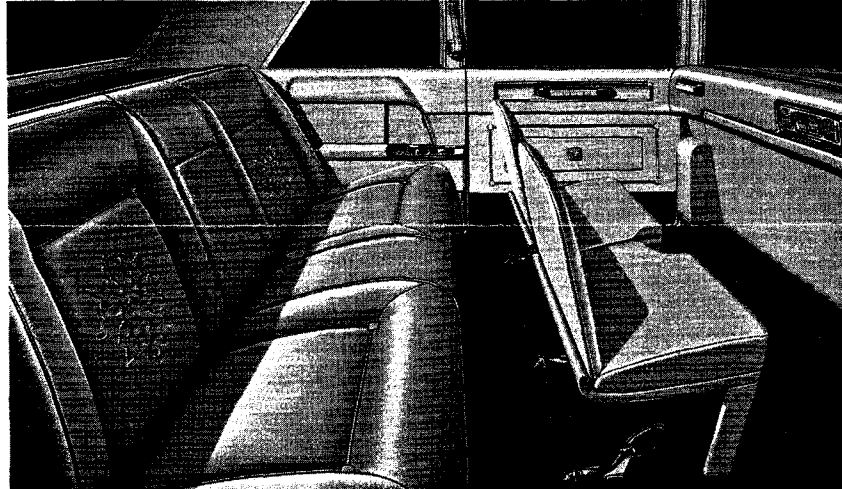
Front Compartment (Decordo Cloth)*Rear Compartment (Danforth Cloth)**Front Compartment (Leather)*

upholstery selections

- 716. Gray Cord Stripe Decordo Cloth.
- 718. Gray Danforth Cloth with embroidered seat-back inserts.
- 719. Medium Gray Cord Stripe Decordo Cloth.
- 726. Midnight Blue Danforth Cloth with embroidered seat-back inserts.
- 744. Beige Danforth Cloth with embroidered seat-back inserts.

chauffeur compartment (Limousine)

Black Natural Finish Leather available with any selection above.

Gray Antique Finish Leather available with Gray selections above.

Midnight Blue Antique Finish Leather available with Midnight Blue selection above.

Beige Antique Finish Leather available with Beige selection above.

padded vinyl covered top options (extra cost)

- 61. White
- 62. Black
- 63. Blue
- 66. Sandalwood

↑
Fleetwood Seventy-Five Sedan and Limousine

standard equipment

Air Cleaner, dry-pack
 Armrest, center, front and rear*
 Assist Handles (two)
 Assist Straps (two)
 Cigarette Lighters, front (two)
 Cigarette Lighter, rear
 Clocks, electric, front and rear compartments
 Footrests, adjustable (two), rear compartment
 Front Seat Adjustment (horizontal, power)
 Heater-Defroster**
 Hydra-Matic Transmission
 Lights, front ash receivers

Lights, backup (dual)
 Lights, cornering
 Lights, courtesy
 Lights, directional signal
 Light, glove box (automatic)
 Light, luggage compartment (automatic)
 Light, map
 Lights, reading
 Mirror, glareproof, rear-view, flip type, shatterproof
 Oil Filter, Full-Flow
 Outside Mirror, left side, remote-control
 Paint, two-tone
 Power Brakes

Power Steering
 Reflectors, safety warning, front door panels
 Robe Cord, back of front seat
 Seat Belts, front**
 Visor Vanity Mirror, shatterproof
 Visors, dual sun
 Wheel Discs (set of four)
 Windows, power
 Windshield Washer and Coordinator

*Rear only on limousine.

**Available without heater-defroster or seat belts as an option at reduced cost.

optional equipment (extra cost)

Air Conditioner
 Controlled Differential
 Cruise Control
 Door Edge Guards
 Head Lamp Control, (Guide-Matic)

License Frames
 Padded Vinyl Roof
 Radio, front compartment controls
 Radio, AM, rear comp't controls
 Radio, AM-FM
 Seat Belts, rear

Soft Ray Glass
 Twilight Sentinel (automatic head lamp timer)
 Vent Windows, front, power
 Whitewall Tires, 8.20 x 15 (set of 5) 6 ply

basic specifications

Wheelbase.....	149.8"
Length, over-all.....	243.8"
Width, over-all.....	79.9"
Height, over-all.....	59.0"
Engine Horsepower.....	340

interior dimensions

	front	aux.	rear
Head room.....	40.2**	37.8***	39.1**
Shoulder room.....	60.4"	58.8"	58.8"
Hip room.....	65.8"	63.2"	59.7"
Leg room.....	40.8"†	—	—
Seat height.....	9.8"	12.7"	13.2"
*Limousine—39.6"		***Limousine—37.0"	
**Limousine—38.0"		†Limousine—39.8"	

1965 Cadillac Optional Equipment

Providing the owner maximum opportunity to individualize his Cadillac helps assure greater motoring satisfaction and enjoyment and increases pride of ownership. Thus it is of special importance that the benefits of each item of optional equipment and accessory in this section be explained *before* he places his order for the car.

Cadillac Comfort Control	Page 50
Soft Ray Glass	Page 51
Tilt and Telescope Steering Wheel	Page 52
Six-Way Power Seat	Page 53
Four-Way Power Seat (bucket seat)	Page 53
Twilight Sentinel	Page 54
Guide-Matic	Page 55
Power Door Lock	Page 55
Automatic Level Control	Page 56
Controlled Differential	Page 57
Cruise Control	Page 58
Rear Window De-Fogger	Page 58
Power Window Regulator	Page 59
Power Vent Window Regulator	Page 59
Power Deck Lid Lock	Page 59
Pre-selector Signal Seeking AM Radio	Page 60
AM-FM Radio	Page 60
Seat Belts	Page 61
Seat Belt Retractors	Page 61
Additional Cadillac Accessories	Page 62
Accessory and Equipment Groups	Page 63

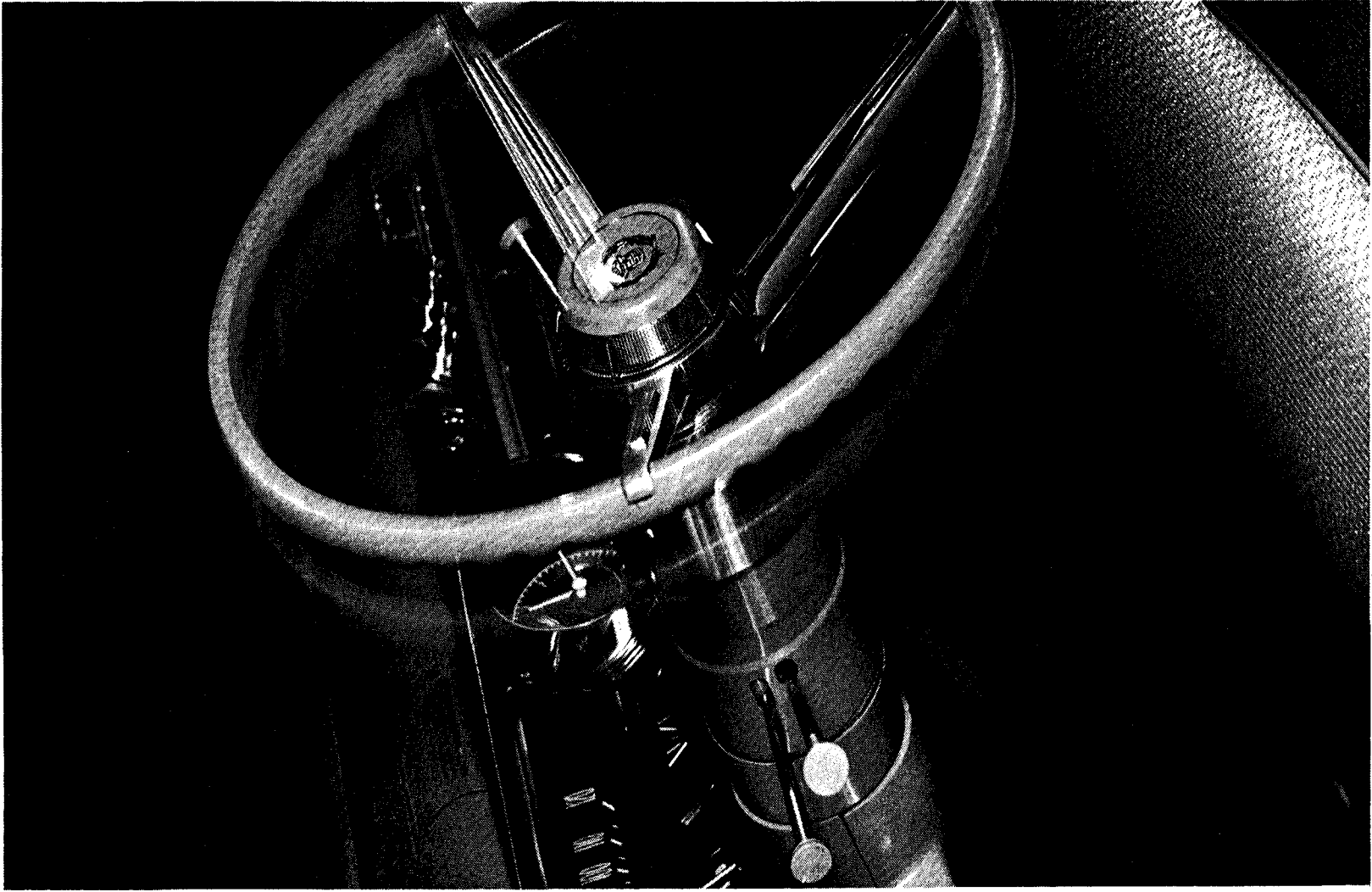

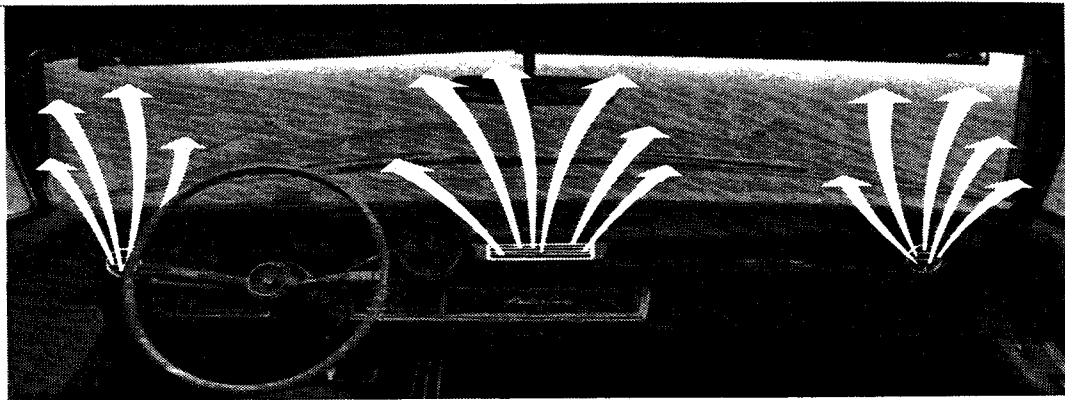

Cadillac comfort control

*(Air Conditioner-
Heater System)*

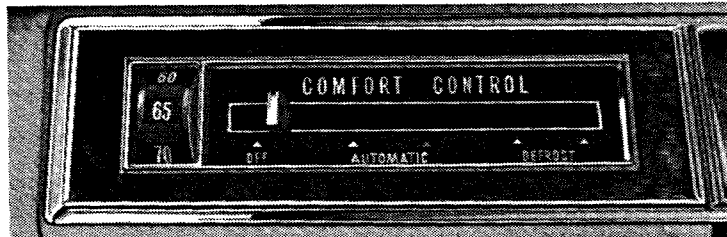

With a temperature selecting dial as simple as that of a home thermostat, Cadillac Comfort Control will bring and maintain the interior of the car to the temperature selected by the driver year 'round, without further adjustment. Having set the dial, to say 70°, the owner can drive from desert heat on up into cold mountain altitudes without any need for dial adjustment. And, when the outside temperature is above approximately 35°, incoming air is directed through the cooled evaporator thus controlling humidity for maximum comfort and minimizing window fogging.

Directing this automatic operation are three temperature sensitive thermistors located to sense outside air temperature, effect of the sun and temperature of air being discharged into the car. They electronically signal other units of the system to achieve the proper blending of heated and/or cooled air and blower speed to hold car interior to temperature setting of the dial.

Comfort Control lever may be set at first position for normal operation or second position (red arrow) for fast cool down when car has been standing in hot sun.

Comfort Control also provides two defrost positions; the first for de-fogging, the second for de-icing the windshield. Higher location of center air-conditioning outlet and larger heater floor duct increase air distribution to rear compartment passengers for 1965.

Fleetwood Seventy-Five model air conditioning- heating system

With their considerably longer length, larger interiors and, in the case of the limousine glass separated rear compartment, the Fleetwood Seventy-Five models have instead of Comfort Control an air conditioning-heating system unique to these body styles. Rear compartment controls are provided in a compartment just off the right-hand rear armrest. In addition, large air-conditioning outlets with adjustable louvers are located in the roof at each side of the rear compartment for maximum air distribution. Heater outlets for the rear compartment are located on the base of the armrests at each side of the rear seat.

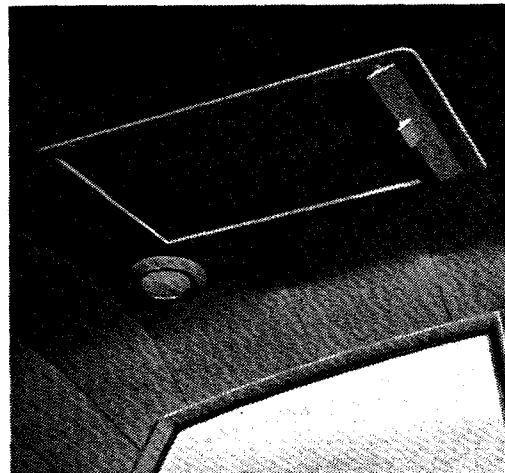
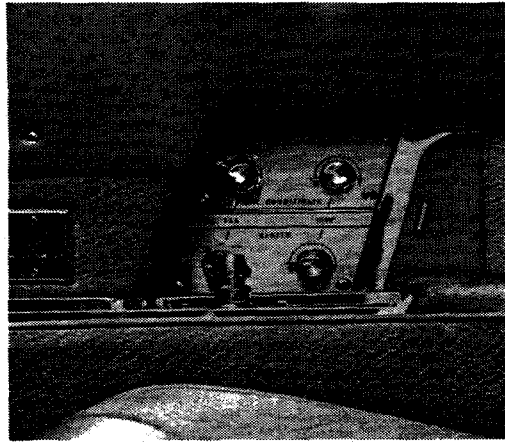

soft ray glass

A natural complement to air conditioned cars, Cadillac Soft Ray Glass shields the interior of the car from the heat and glare of the sun for increased comfort and improved visibility. Available on all Cadillac models, Soft Ray Glass installation includes tinted glass on all windows (except the rear window of convertible body styles) with additional shading on the upper portion of the windshield.

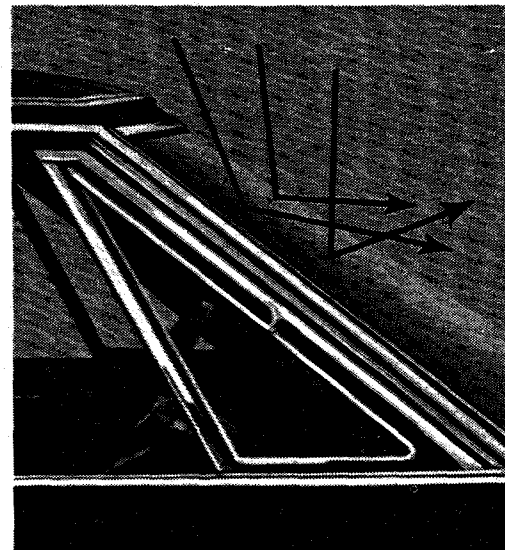

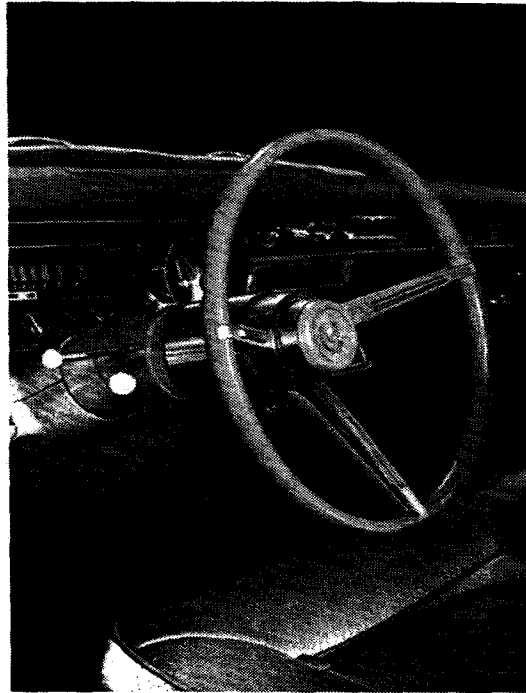
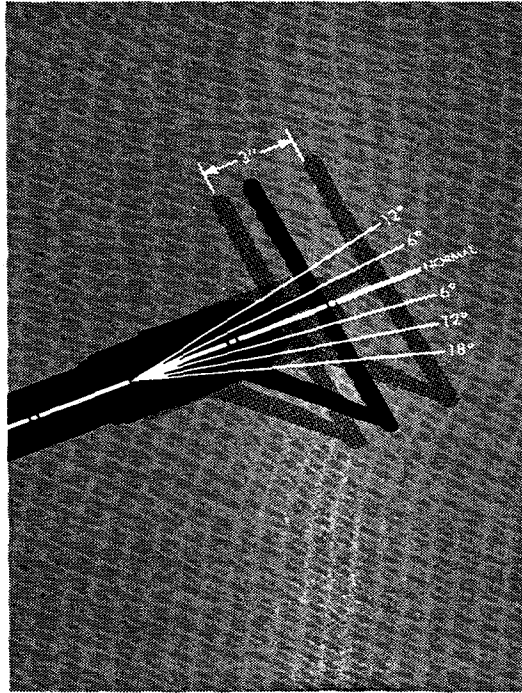

Cadillac tilt and telescope steering wheel

To all of the much appreciated advantages of being able to tilt the steering wheel to any of a wide range of positions, Cadillac has added the plus benefit of a telescoping adjustment which permits moving the steering wheel closer to, or farther away from the driver over a 3-inch range of adjustment. Turning the center hub of the steering wheel counterclockwise permits telescoping to length desired; turning hub clockwise locks wheel in position. This exclusive new feature assures that any member of the Cadillac owner's family may precisely adjust the steering wheel to the most natural and comfortable position for his or her driving habits. On long trips the ability to change the tilt or telescope position of the steering wheel while driving is a major aid in relieving tension and minimizing fatigue. Varying the tilt adjustment is achieved simply by lifting upward on a small lever located on the left side of the steering column just below the turn signal indicator, moving the steering wheel to the desired angle then releasing lever to lock wheel in position.

As a further benefit for ease in entering or leaving the car, the Tilt and Telescope Steering Wheel is spring loaded so that lifting the lever automatically tilts the steering wheel to its uppermost position.

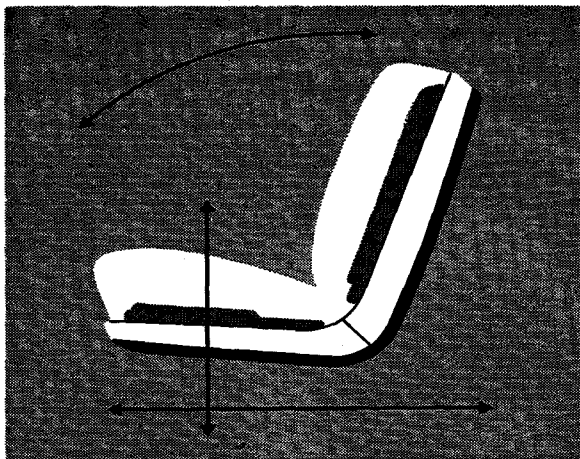
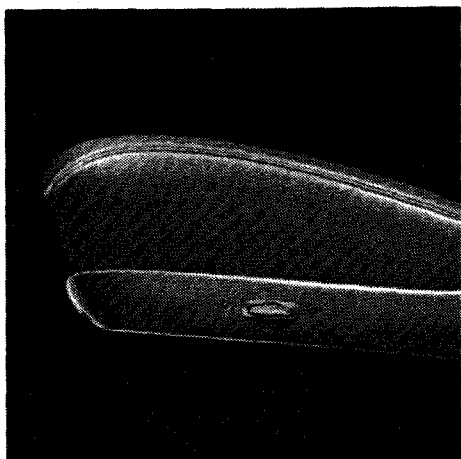

power seat adjustment (six-way)

The Six-Way Power Seat Adjustment permits horizontal, vertical and angle adjustment for maximum seating comfort. Only the vertical and seat-angle provisions need be ordered on models where horizontal adjustment is standard. The Fleetwood Eldorado with regular front seat has the six-way seat adjustment as standard. Horizontal adjustment only is provided on Seventy-Five models.

power seat adjustment (four-way for bucket seats only)

The Four-Way Power Adjustment permits horizontal and seat-angle adjustment for the driver's seat of bucket seat equipped models. It is standard on the Eldorado. Horizontal adjustment only is provided as standard with bucket seat option.

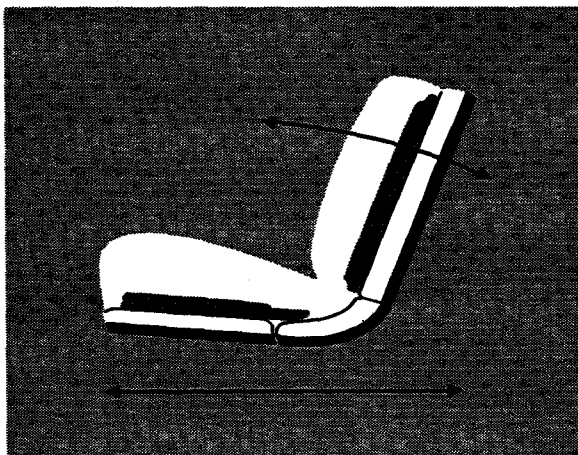
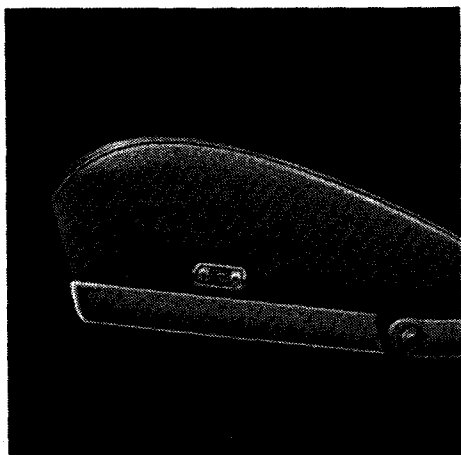

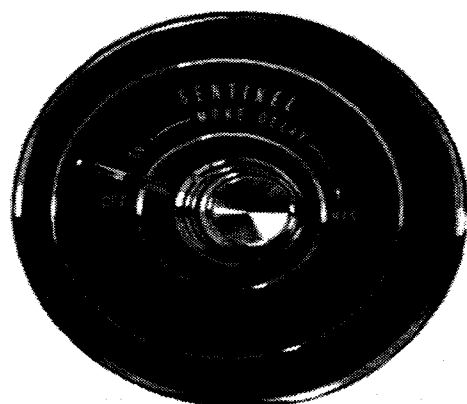
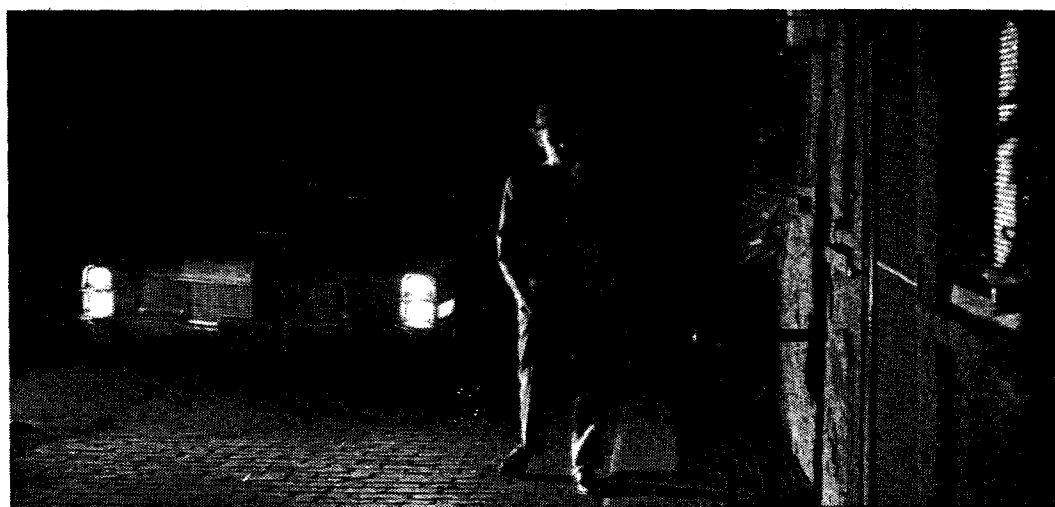

**twilight
sentinel**
(automatic
headlamp timer)

The Cadillac Twilight Sentinel with controls conveniently located on the headlamp switch nacelle provides two major benefits. When ignition is ON and the Twilight Sentinel control knob turned to automatic position, the headlights of the car will turn on automatically with approach of dusk, on storm-darkened days, in fog or vision-obscuring sand and dust. When sufficient daylight returns headlights are automatically turned off. With Twilight Sentinel knob in manual position, the headlamp switch is used to turn lights on or off to meet such special requirements as when driving in funeral processions or through brightly lighted tunnels.

Twilight Sentinel also provides a delayed shut-off provision which permits leaving headlights and either cornering light (as determined by position of the directional signal lever) lighted for up to a minute and a half after turning off the ignition, thus providing a pathway of light away from the car for added nighttime security.

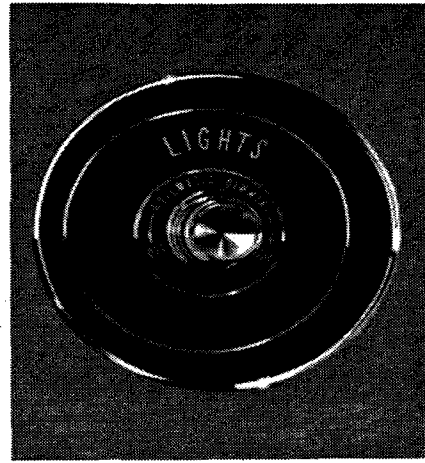
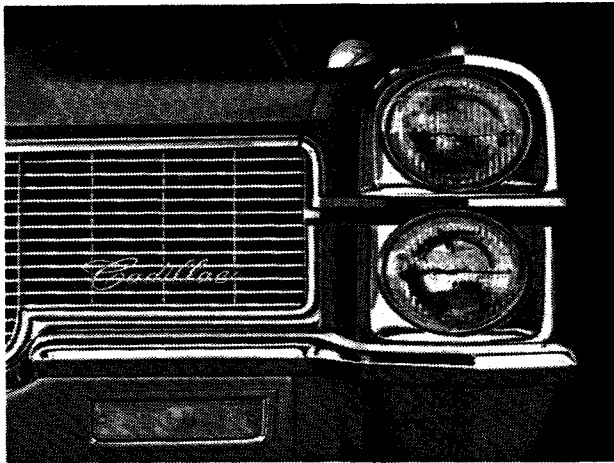

guide-matic (headlamp control)

Guide-Matic controls, too, are newly located on the headlamp switch nacelle. As a contribution to safer nighttime driving, Guide-Matic automatically dims the headlights of the Cadillac owner's car when another approaches from the opposite direction or when the Cadillac driver draws closer to the taillights of a car ahead. An overriding switch is provided to signal drivers who neglect to dim their bright lights in return. New location of the Guide-Matic photocell behind the radiator grille assures maximum sensitivity to headlamps and taillights of other cars without interference from overhead lighting. In addition, the Guide-Matic control may be adjusted by the driver to provide just the right degree of photocell sensitivity to meet his preference.

power door locks

Cadillac Power Door Locks are especially appreciated by women or when children are passengers. Simply pressing down either front door lock button locks all doors; lifting button or opening front door with inside handle unlocks all doors. New convenience for 1965, especially in bad weather, is that all doors are automatically unlocked when driver turns key in either front door.

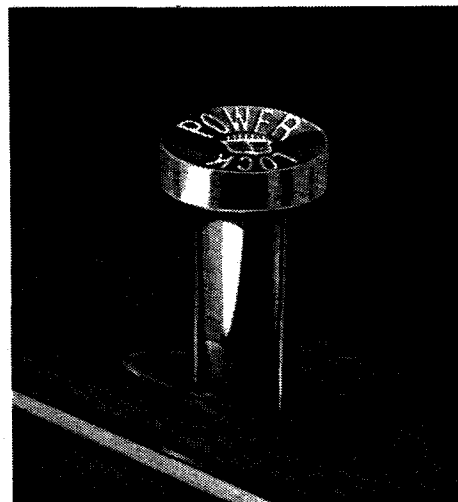

Cadillac automatic level control

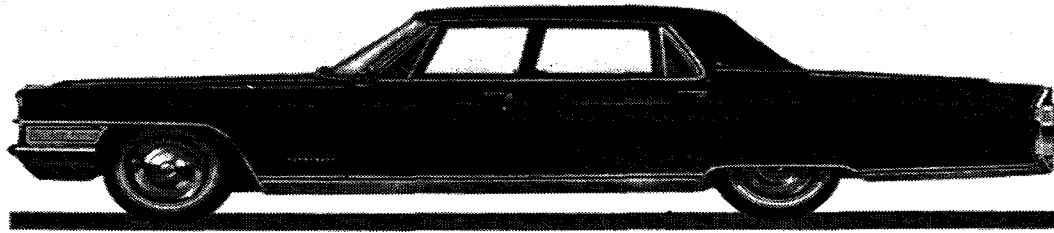

Car always rides level . . .

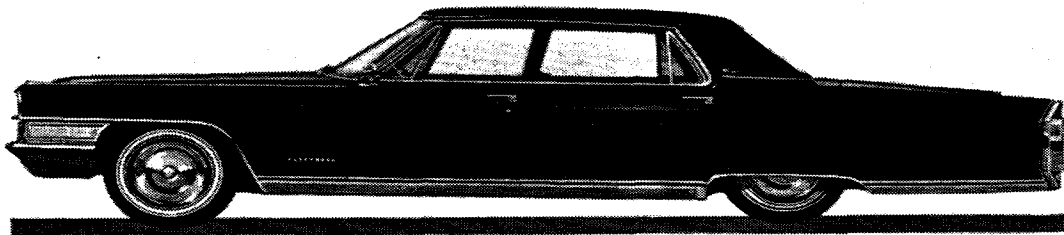

never rear end dip regardless of load.

The new Cadillac Automatic Level Control keeps the car level with the roadway regardless of rear compartment, luggage compartment or trailer loading. The benefits, in addition to maintaining best appearance, are better handling, more accurate headlamp aiming, minimum possibility of "bottoming" even on severe bumps, and less chance of the rear bumper scraping the ground when car encounters a steeply angled ramp or driveway. Of importance to any Cadillac owner, these features are certain to have special appeal to sportsmen, salesmen and motoring vacationists.

In operation the Automatic Level Control provides pressurized air from a compressor and air reservoir to a

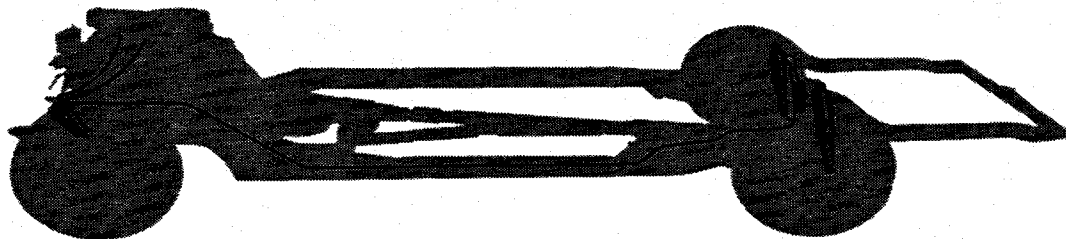

valve located on the rear crossmember of the frame. Whenever there is sufficient rear end loading to deflect the suspension (or springs) one-half inch or more, the valve opens permitting pressurized air to enter special air chambers in the shock absorbers, thus extending the shock absorbers to bring the car back to level height. When weight is removed, the valve is reactivated to permit exhausting of air from the shock absorbers to lower the car again to a level height.

To assure height adjustment only when required by loading conditions, the valve has a six to twelve second delay mechanism; thus normal deflection of the rear suspension due to irregular road surfaces does not activate the level controls.

The Cadillac Automatic Level Control is included as standard equipment with the Fleetwood Eldorado Convertible, Sixty Special Sedan and Brougham option.

Cadillac cruise control

Set the Cruise Control dial (illuminated for night) to speed desired, accelerate to that speed, then move switch to AUTO (automatic) position and car will maintain the selected speed without the driver's foot on the accelerator pedal. While brake application immediately releases Cruise Control, it will again maintain driver's pre-selected speed when car is accelerated to the speed setting. A red light reminds driver when Cruise Control is on AUTO position. Moving switch to OFF or turning ignition off disengages automatic operation entirely. Cruise Control also serves as a speed warning indicating by back pressure on the accelerator pedal whenever driver tends to exceed his chosen speed as indicated by the dial setting.

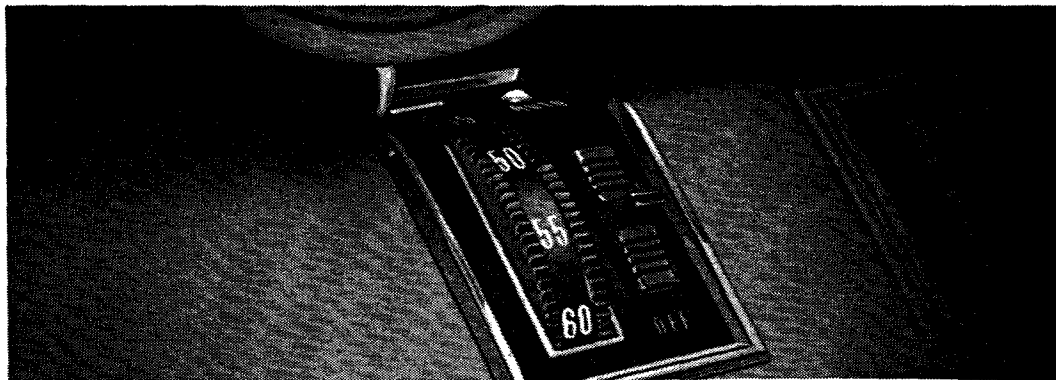

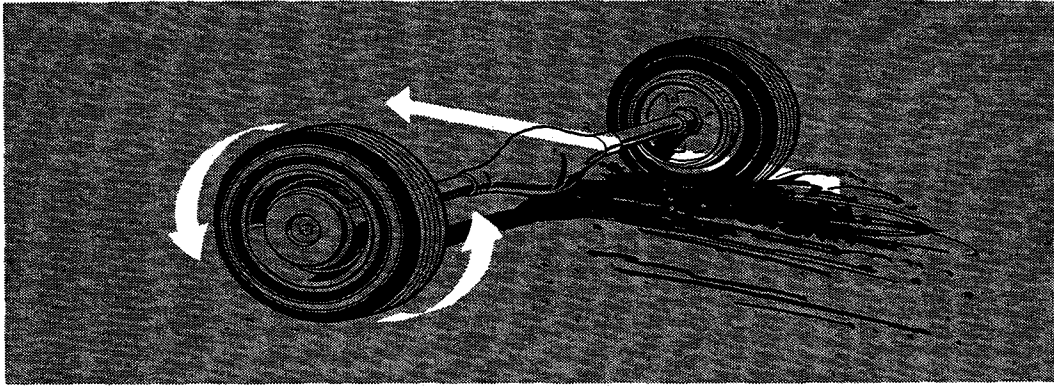

controlled differential

Because it always directs driving force to the rear wheel having the better traction, Cadillac's Controlled Differential assures maximum mobility on such skid-inducing surfaces as ice, snow, sand, mud, gravel and wet or oily pavement. For the same reason, the Controlled Differential reduces swerving on high crowned roads, provides greater resistance to skidding, adds stability on washboard roads, and contributes to increased tire life.

rear window de-fogger (dealer installed only)

The Cadillac Rear Window De-Fogger has been designed with a larger, more centrally located rectangular air outlet which distributes fan-blown air across the rear window keeping it free of fog or mist. In winter it helps prevent accumulation of snow or ice on rear window glass. Operates at either of two speed settings.

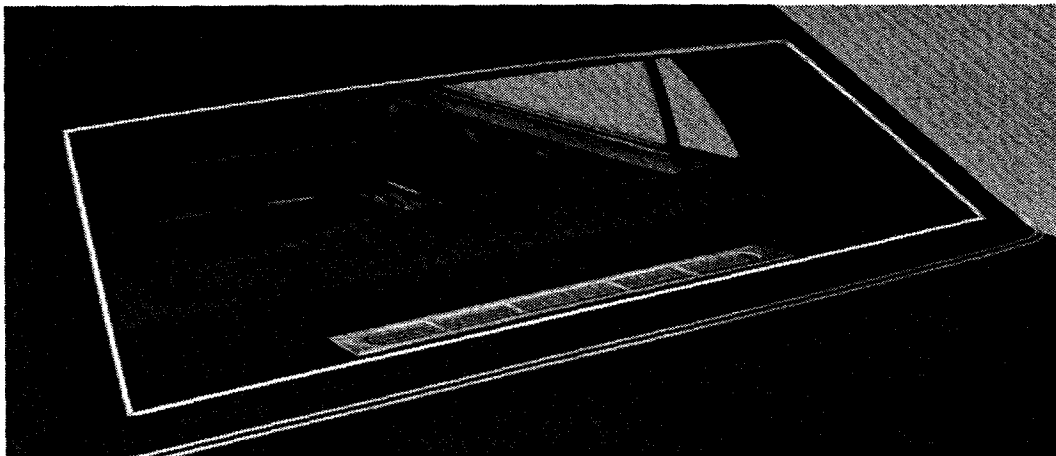

power window regulators

Permit raising or lowering windows from four-switch panel just forward of armrest on driver's door. Single switches are provided for passenger operation of individual windows. A switch is provided which may be set to lock out all but driver's window regulators; to permit power operation only when the ignition is ON or, in EMERG (emergency) position to permit power window operation even with ignition OFF. Power Window Regulators are standard except on Calais models.

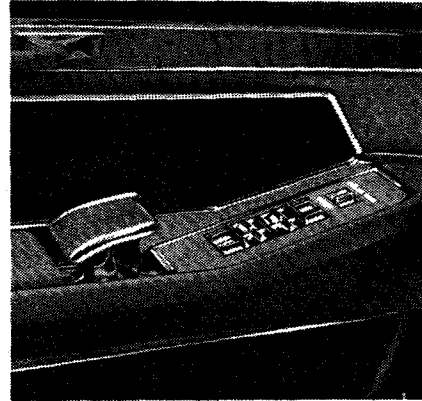

power vent window regulators

Available on all models when equipped with power windows. Standard on the Fleetwood Sixty Special and Eldorado. An additional two switches are provided on driver's control panel, a single switch on the opposite door.

power deck lid lock

The Cadillac Power Deck Lid Lock provides the owner the added convenience of being able to release and slightly raise the deck lid for service or shopping attendants simply by pushing a button at the left side within the glove compartment. A red warning light on the instrument panel indicates when deck lid is unlocked. Available on all but Fleetwood Seventy-Five models.

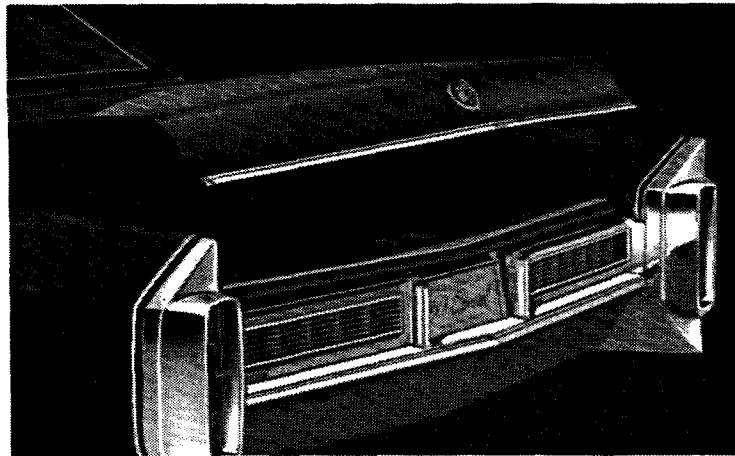



Cadillac signal-seeking pre-selector AM radio

The Cadillac AM Radio has superb tone, wide range of adjustment for base or treble, and permits sound to be directed to front and rear speaker or balanced between the two. It is transistorized for instant operation and has a printed circuit for maximum dependability. Tuning is permitted manually, by five favorite station push buttons or by a selector bar for automatic tuning of each successive station within range. Selector bar may be set for only strongest stations or, by moving MORE STATIONS switch to right, will pick up weaker or more distant stations. Antenna may be raised to any degree of its full height or fully recessed into fender.

Cadillac AM/FM radio

The Cadillac AM/FM Radio adds the enjoyment of the more sophisticated FM programs. And FM radio rejects outside electrical interference and generally has fewer commercials. The Cadillac FM Radio also features Automatic Frequency Control thus, even when slightly mistuned manually, the radio tends to lock directly onto the station wanted without interference from adjacent stations. Reception is generally best with FM up to some 20 miles from the transmitting station. Beyond this distance choosing another FM station or switching to AM may be preferred. Bar over radio is marked for AM or FM.

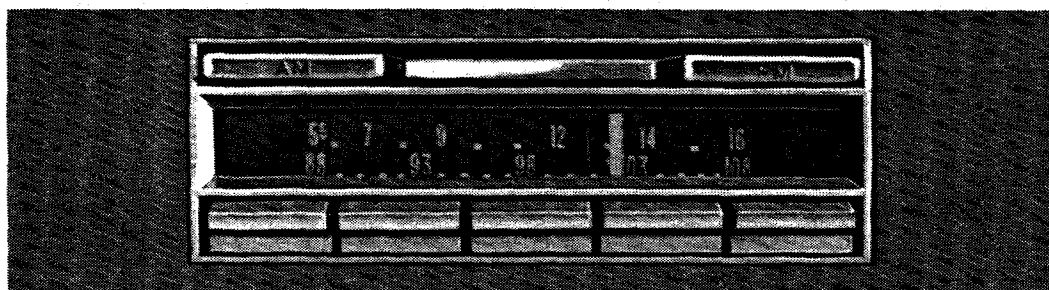

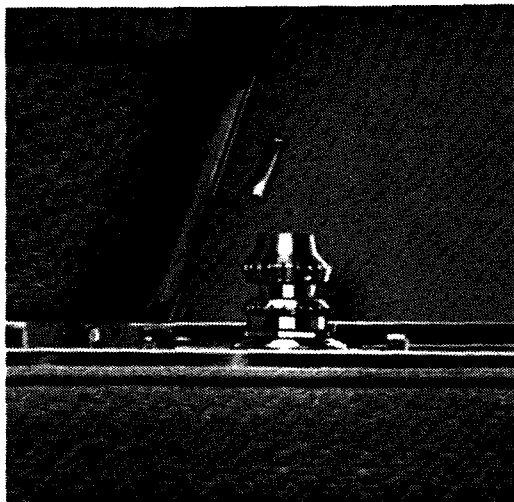

rear compartment radio controls

(Fleetwood Seventy-Five only)

The Cadillac Radio available for the Fleetwood Seventy-Five Sedan and Limousine is provided with rear compartment controls which are located on the right-hand rear armrest for operation by rear compartment passengers. This radio has AM reception only.

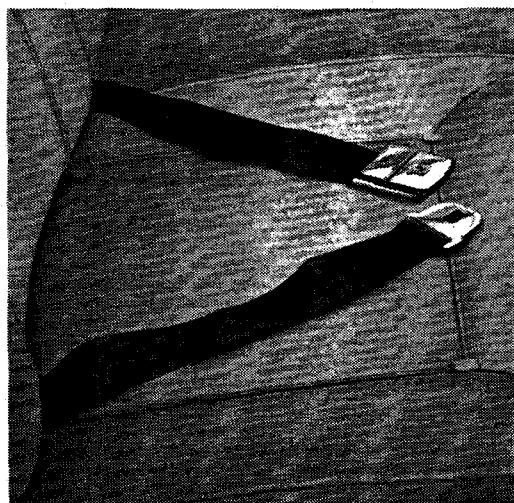

Cadillac seat belts

Identified by a distinctive Cadillac Crest on the buckle, Cadillac Seat Belts meet or surpass all national safety standards. Seat belts need only be ordered for the rear compartment since they are already provided as standard equipment in the front. All Cadillac Seat Belts are color harmonized with Cadillac interiors.

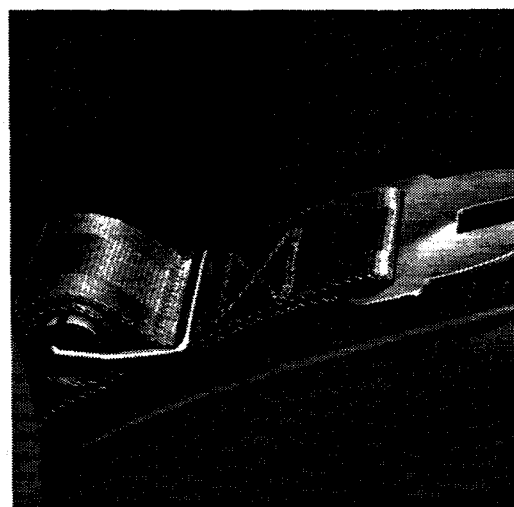

seat belt retractors

Cadillac Seat Belt Retractors are already provided on the door-side seat belts in the front compartment thus keeping them neatly rolled up away from the door sill when not in use. Seat Belt Retractors especially designed for simple and easy installation are also available for use with rear seat belts.

additional Cadillac accessories

Rear Compartment Remote-Control Radio (Fleetwood Seventy-Five only)	\$ _____
Radio Foot-Control Switch	\$ _____
Cadillac Cushion Covers	\$ _____
Cadillac Rubber Floor Mats	
Contoured Front (Full-width)	\$ _____
Contoured Rear (Full-width)	\$ _____
Contoured Front (2-piece)	\$ _____
Contoured Rear (2-piece)	\$ _____
Cadillac Luggage Compartment Mat	\$ _____
Cadillac Compass	\$ _____
Cadillac Litter Box	\$ _____
Cadillac Eldorado Horn	\$ _____
Door Edge Guards	\$ _____
Spare Tire Cover	\$ _____
Windshield Washer Anti-Freeze and Gas Line De-Icer	\$ _____
Body Polish	\$ _____
Fabric Cleaner	\$ _____
Kar-Kleen Upholstery Cleaner	\$ _____
Blue Coral	\$ _____
Blue Coral Sealer	\$ _____
Magic Mirror Cleaner and Polish	\$ _____
Magic Mirror Cream Wax	\$ _____
Chrome Cleaner	\$ _____
Cooling System Inhibitor and Sealer	\$ _____
Whitewall Tire Cleaner	\$ _____
Tar and Road Oil Remover	\$ _____
Vinyl, Leather and Convertible Top Cleaner	\$ _____

**1965 Cadillac
accessory &
equipment options**
(factory-installed groups and codes)

<p>1 X Windows, Power W Tires, Whitewall R Radio, AM E Glass, Soft Ray Y { Seat Adjuster, or { <i>6-way front</i> T { Seat Adjuster, D { <i>4-way driver's bucket</i> K Door Edge Guards Comfort Control <i>(air conditioner)</i></p>	<p>2 X Windows, Power W Tires, Whitewall R1 Radio, AM-FM E Glass, Soft Ray Y { Seat Adjuster, or { <i>6-way front</i> T { Seat Adjuster, D { <i>4-way driver's bucket</i> K Door Edge Guards Comfort Control <i>(air conditioner)</i></p>
<p>3 X Windows, Power W Tires, Whitewall R Radio, AM E Glass, Soft Ray Y { Seat Adjuster, or { <i>6-way front</i> T { Seat Adjuster, D { <i>4-way driver's bucket</i> Door Edge Guards</p>	<p>4 X Windows, Power W Tires, Whitewall R1 Radio, AM-FM E Glass, Soft Ray Y { Seat Adjuster, or { <i>6-way front</i> T { Seat Adjuster, D { <i>4-way driver's bucket</i> Door Edge Guards</p>
<p>5 U Headlamp Control, Guide-Matic Q Steering Wheel, Tilt and Telescope M Door Locks, Power J Twilight Sentinel S Trunk Lock, <i>remote-control</i> G Controlled Differential C Cruise Control N Vent Windows, Power P Level Control, <i>automatic</i></p>	<p>OTHER CODES 8 License Frame, One or 9 License Frames, Two F Filler Plate A Seat Belts, 2 Rear R2 Radio, Rear Control (AM)—Fleetwood 75 only</p> <p>OPTIONAL GEAR RATIO 1 3.21 7 3.77—Fleetwood 75 only O Seat Belts, 2 Front Deletion Option H Heater-Defroster Deletion Option</p>

Standard equipment on all cars includes two front seat belts and heater-defroster. However, a deletion option is available at reduced cost. The heater-defroster is an integral component of Comfort Control and cannot be deleted when this feature is ordered. Tilt and Telescope Steering Wheel, Remote-Control Trunk Lock, Automatic Level Control and Comfort Control are not available on Fleetwood Seventy-Five models. To order Air Conditioner, use same symbol K.

1965 Cadillac power train

- engine**
- transmission**
- drive line**

Converting the energy released by fuel combustion into a smooth, quiet, dependable flow of power to the rear wheels is the function of the Cadillac engine, transmission and drive line . . . the Power Train. And with all of its recognized efficiency in the past, the Cadillac Power Train for 1965 accomplishes this function with a new quietness and selective flexibility. Here is power eager and able to meet the varied demands of your most exacting owners, yet delivered through a Power Train so efficiently designed and engineered as to make its performance truly sensed but not heard.

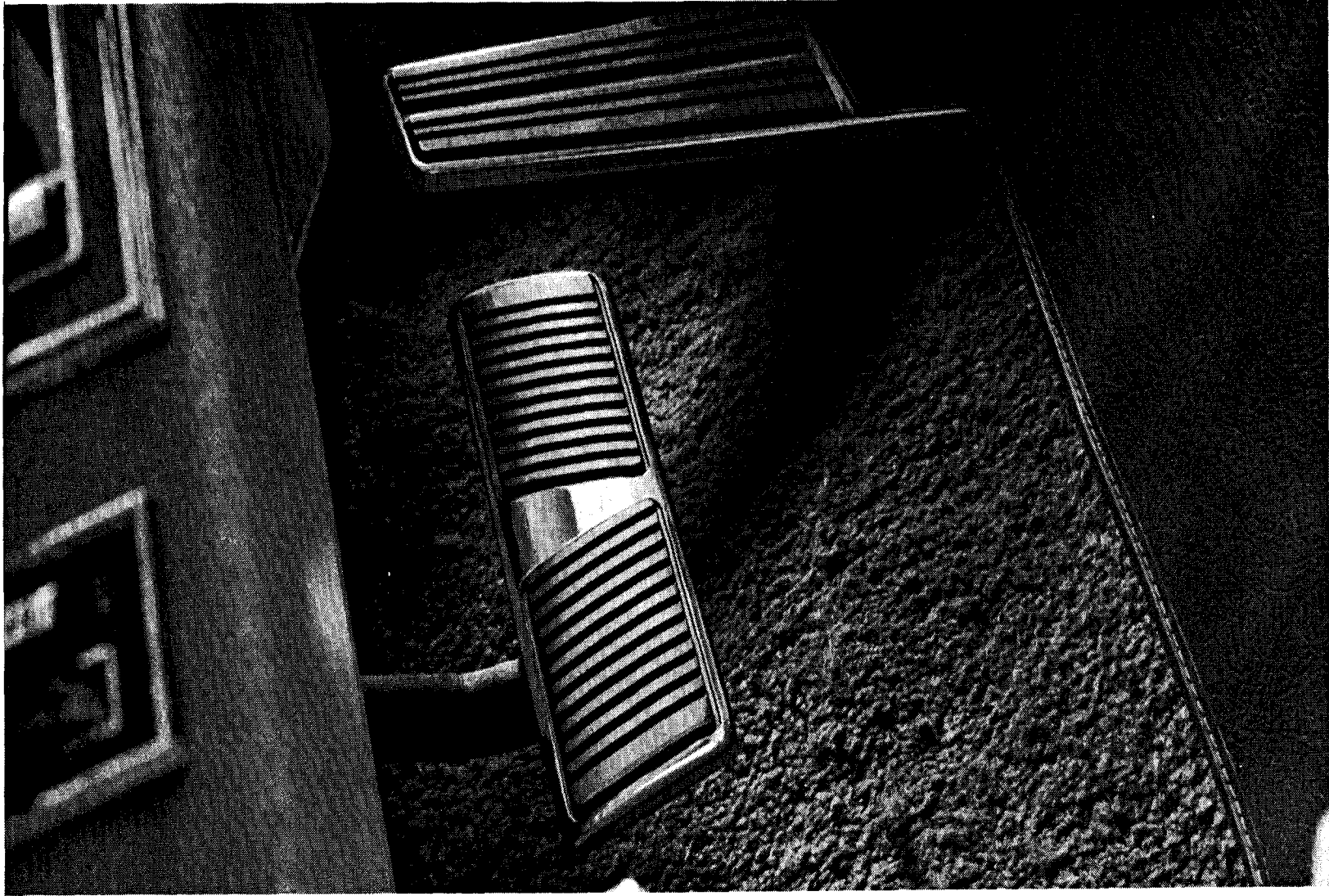

Cadillac engine 1965

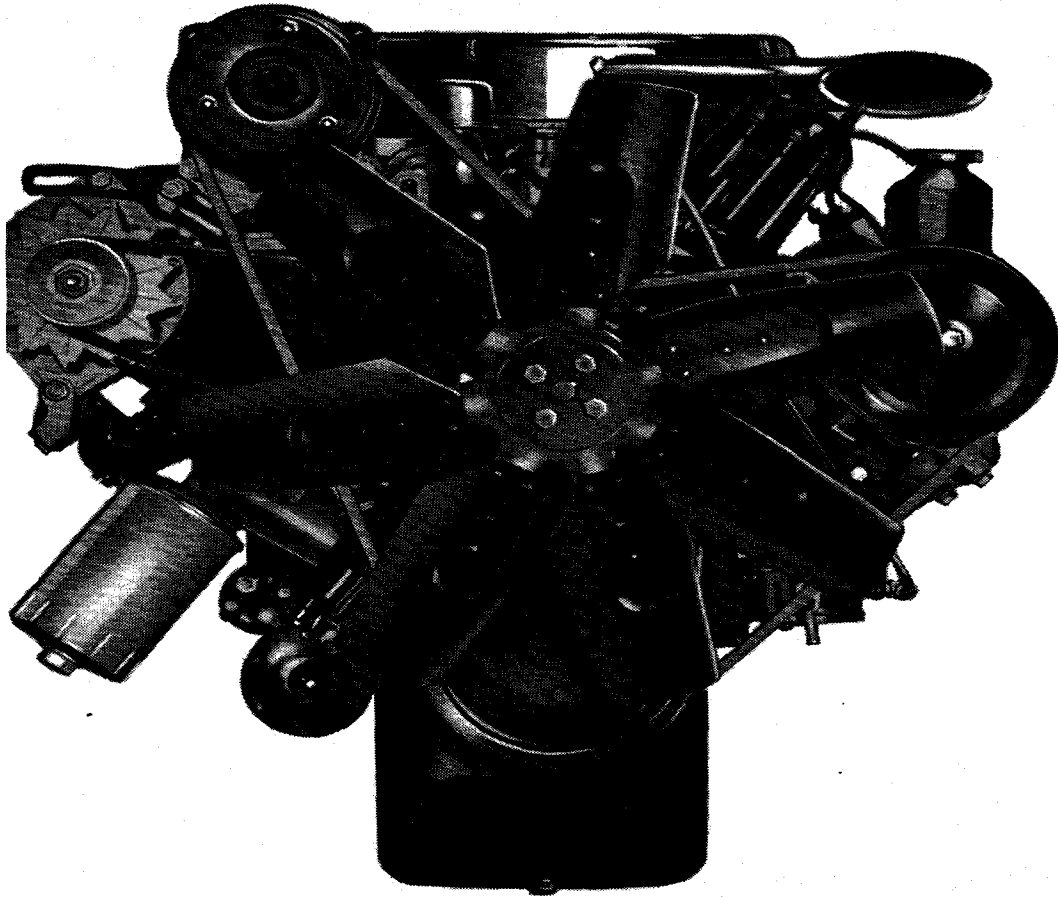

Designed for maximum efficiency and performance without useless weight or bulk, the Cadillac engine has a higher horsepower-to-weight ratio than any competitive motor car in the industry. For 1965, advances in piston head design, exclusive new exhaust system and new engine mountings, which isolate engine pulsations from the interior of the car, assure Cadillac owners the smoothest, quietest engine performance that skilled engineers utilizing the latest electronic computers have yet devised.

Cadillac power train

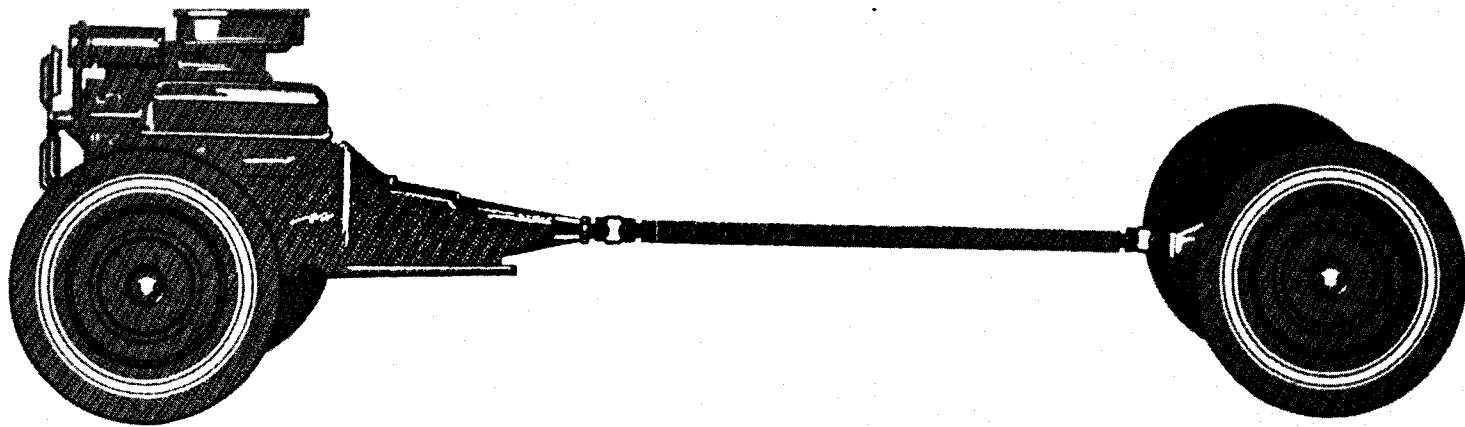

Brief new highlights of the smoothest power train in motoring

New idling smoothness and engine isolation. New engine mountings proven by electronic computer data and engineering tests permit normal engine roll at idle without conflicting motions (pitch and yaw) associated with rough idling.

New Turbo Hydra-Matic transmission with variable stator offers driver wider selectivity of acceleration; dual Drive range for choice of engine braking and performance desired.

New plastic deadener and centering ring gives transmission gears noiseless operation in drive range.

New one-piece propeller shaft with two CV (constant velocity) joints is quiet, vibration resistant.

New rear axle housing of more unified construction, minimum welds for added strength and rigidity.

New rear wheel bearings with both races and bearings pre-stressed for increased durability and long life.

New 9.00 x 15 whitewall tires (standard on the Fleetwood Eldorado Convertible and optional at extra cost on other models except the Fleetwood Seventy-Five), have new tread design extending onto shoulders of tires. Added benefits include maximum quietness and smoother cornering, better traction and increased directional stability.

details of Cadillac engine features for 1965

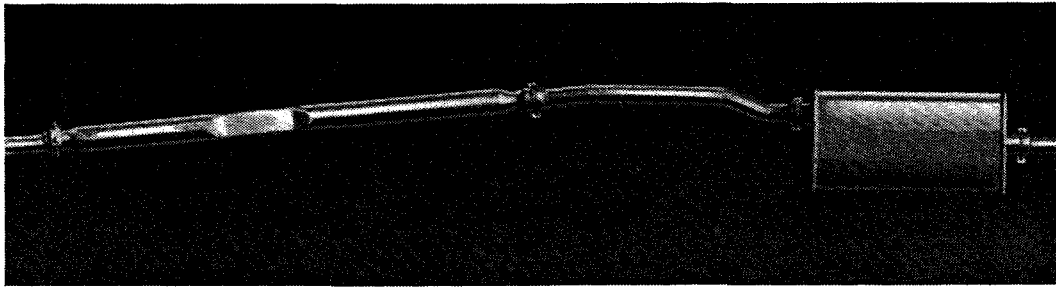

new coaxial resonator exhaust system

Unlike conventional exhaust systems where the varying lengths of pipe result in many resonances of sound, the new Cadillac exhaust system has the muffler at the exact sonic center of the system. The pipes before and after the muffler are tuned to an identical resonance thus leaving only this single resonance to be controlled to eliminate exhaust "booms." This is accomplished by the new coaxial resonator consisting of two chambers around a center pipe. It is designed so that after exhaust noise from the engine enters the resonator it is bounced back completely out of phase with the incoming sound so that the notes cancel out each other. The result is the quietest, most unobtrusive exhaust system even Cadillac owners have ever enjoyed.

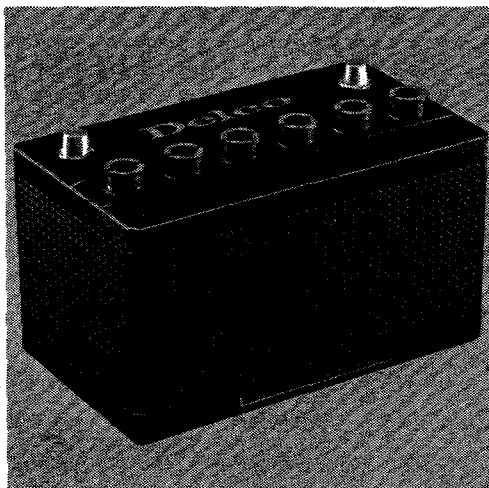

new battery

The Cadillac battery for 1965 has cell connectors passing through rather than around the cell partitions, thus providing a shorter electrical path with minimum restriction. The result is increased ignition voltage and engine cranking speed for surer cold weather and hot engine starts. Battery has new snap-in mounting provision and improved one-piece sealed top.

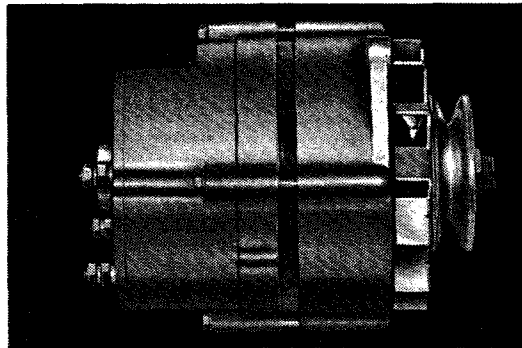
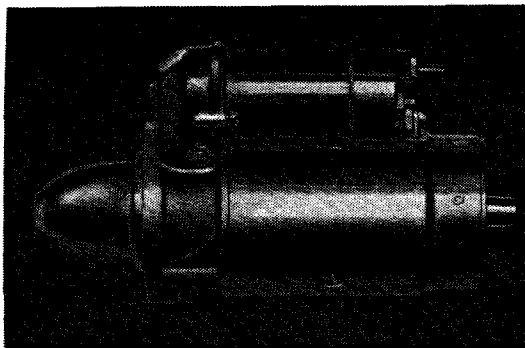

starting motor, generator, generator regulator

Powerful starting motor has gear teeth especially designed for strength, quietness and long life. Improved sealing and enclosure of solenoid lever within housing provide maximum wet weather protection. High output generator with lubricated-for-life bearings has 42 amp. rating (55 on air-conditioned cars). Generator regulator has hard gold contact points for maximum dependability and long life.

new 7-blade fan

With blade spacing and profile determined by electronic computer, the exceptional quietness and cooling efficiency of the Cadillac fan eliminates any need for thermostatic control as previously provided on air-conditioned cars.

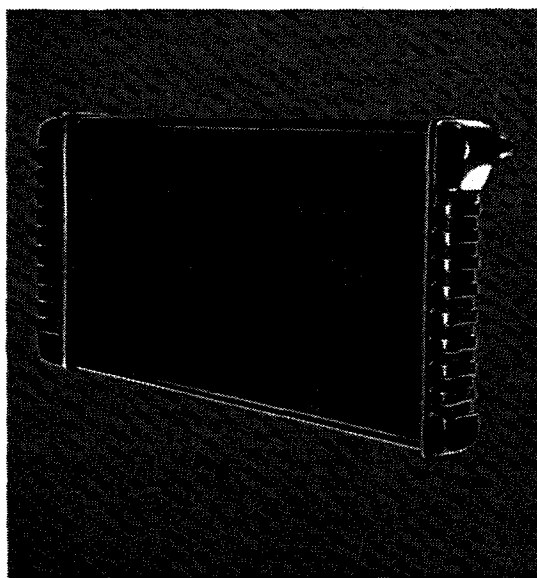
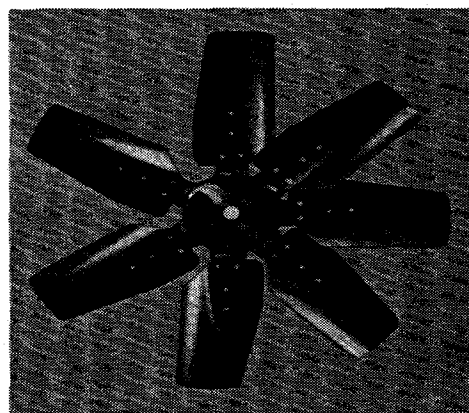

new cross-flow radiator

The new Cadillac cross-flow radiator has no top and bottom tank to disturb air flow and create noise. It requires no surge tank, is quieter and has fewer potential leak points. It permits lower hood silhouette and grille design.

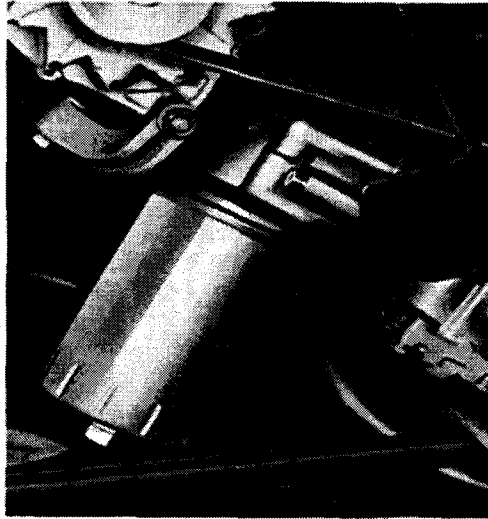

new oil filter location

The Cadillac full-flow oil filter removes impurities and abrasive particles from the oil for maximum engine efficiency and long life. For 1965 the oil filter has been repositioned in the engine compartment at an angle for better servicing accessibility.

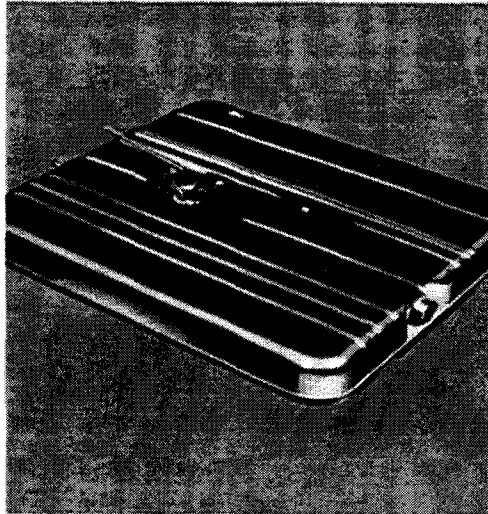

Improved fuel tank venting

Minimizing any possibility of spillage of fuel on the deck sill or bumper during refueling and helping to prevent overflow is an improved venting system for the fuel tank. Hinged license plate holder also provides ready access to fuel filler tube.

crankcase ventilation system

Cadillac's positive crankcase ventilation system directs unburned air-fuel mixture from the crankcase back to the intake manifold for re-burning.

A vent valve regulates the volume of unburned air-fuel mixture to assure proper ratios for smooth performance at various engine speeds and loads.

Cars delivered in California have a closed ventilation system with an unvented crankcase breather cap and provision to direct any excessive unburned fuel-air mixture from the crankcase to the air cleaner instead of venting it to the outside air.

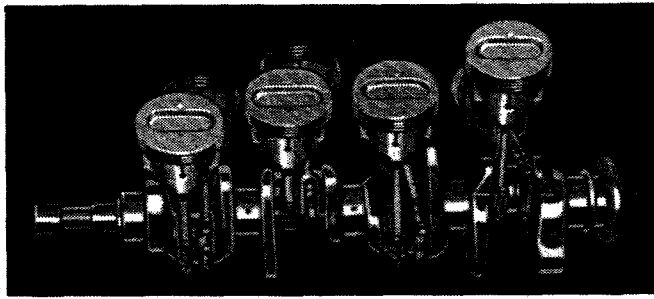

**piston-crankshaft
assembly**

The Cadillac engine has a short, rigid crankshaft for strength and efficiency without excess weight. Pistons are lightweight, have new head contour for increasing turbulence and combustibility of fuel-air mixture. Lightweight moving parts minimize starting inertia, reduce friction.

dual fuel filters

Cadillac provides the owner dual filter protection, a fine-woven, self-cleaning, saran-plastic filter in the fuel tank plus a sediment bowl-type filter in the engine compartment.

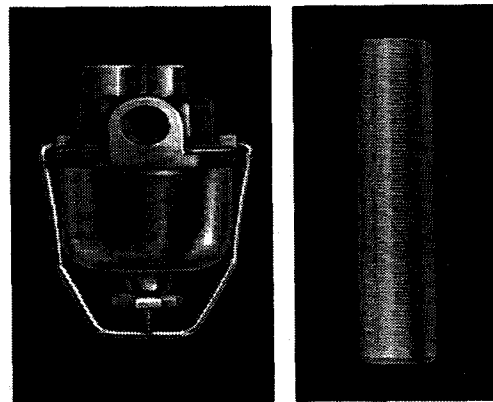

warm-up efficiency

Cadillac's automatic choke control enriches the fuel mixture only when needed. As engine warms up, hot gases flow through tube A to choke control B which then reduces richness of fuel mixture.

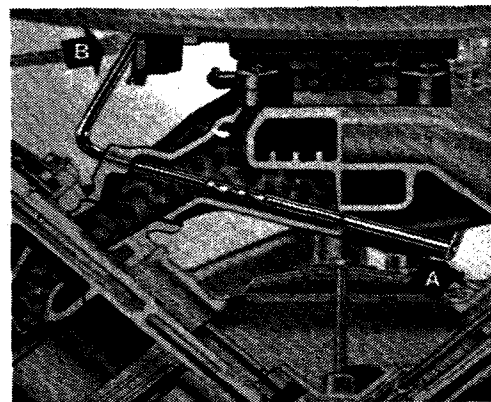

smooth idling

Under sustained idling fuel may boil and be forced into the carburetor causing roughness or engine stalling. Cadillac provides a heat sensitive valve which prevents this by directing additional air to the carburetor to maintain proper air-fuel mixture.

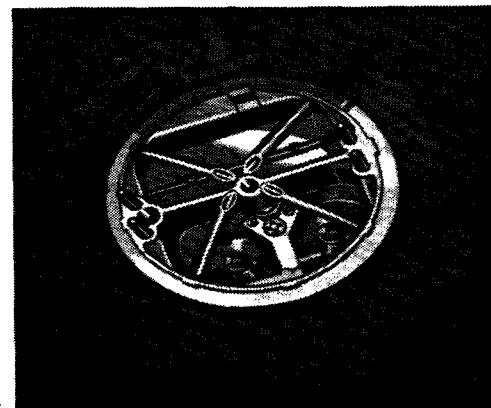

Turbo Hydra-Matic transmission features

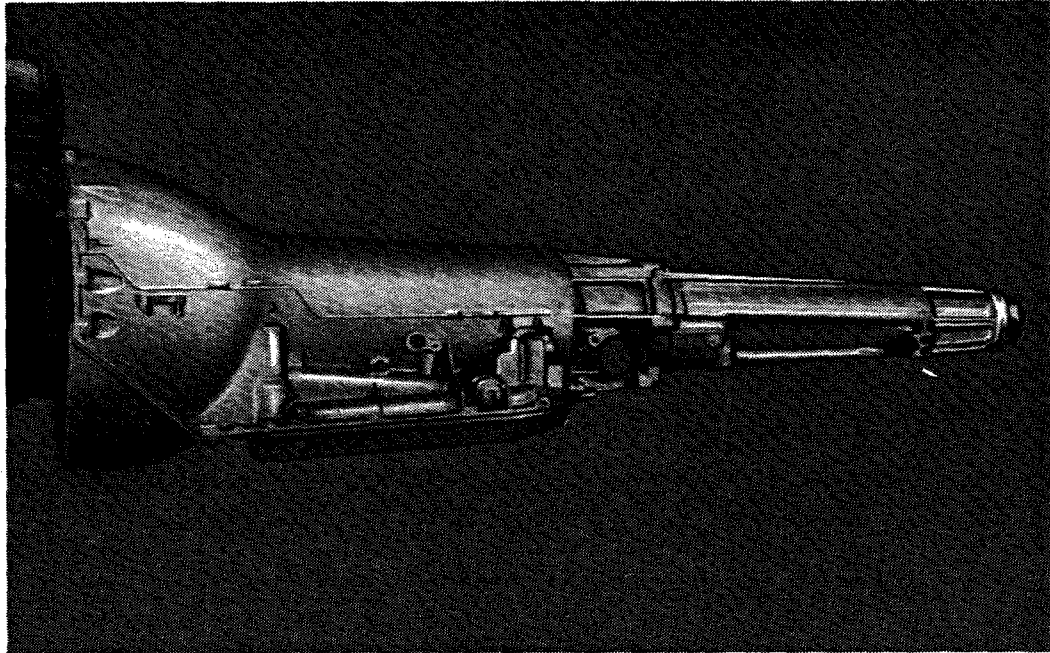

The introduction of the Cadillac Turbo Hydra-Matic transmission brought to Cadillac owners increased flexibility in meeting varying driving conditions and a new alacrity in acceleration, in traffic or on the open highway. For 1965 the Turbo Hydra-Matic transmission provides these benefits in still greater measure and with an even wider selectivity in degree of acceleration desired, in amount of engine braking and in the choice of two Drive ranges, always a popular feature among Cadillac owners.

The added selectivity of acceleration has been achieved through the addition of a variable stator to the torque converter unit. When the accelerator is depressed about halfway the pitch of the stator vanes is such as to deliver maximum torque (and acceleration). When lesser torque is called for by less depression of the accelerator pedal the pitch of the stator vanes is reduced. This condition is designed to aid the precise maneuvering required in parking, to prevent creeping in idle, and for acceleration where urgency is not a factor.

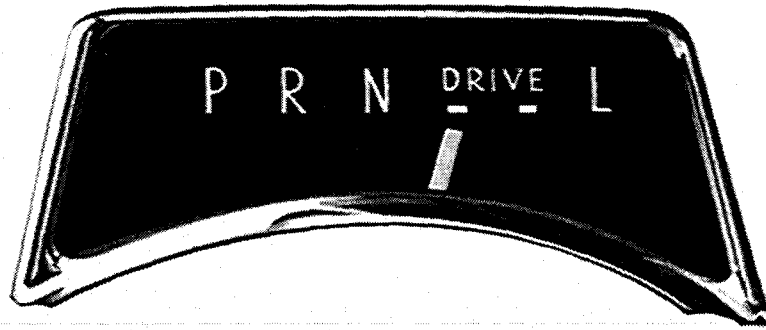

drive range—(left-hand position)

With the Turbo Hydra-Matic selector in the left-hand DRIVE range position the owner is assured of maximum cruising economy and quietness and slower engine speeds. At the same time, the owner enjoys any degree of acceleration he desires from the fluid-smooth thrust of the torque converter to the surging acceleration provided by depressing the accelerator pedal halfway to change the stator vane pitch, or, all the way for additional acceleration by engaging a lower gear.



drive range—(right-hand position)

Placing the Turbo Hydra-Matic selector in the right-hand DRIVE position locks out high gear and utilizes the intermediate gear for maximum responsiveness and increased engine braking. It is often the preferred position for driving in hilly terrain where instant maneuverability without repeated need for brake application is desirable. It is especially effective in mountain driving to hold the car on downgrades and to provide the power and agility to climb the steepest hills.

Cadillac drive line

The final phase of the Cadillac Power Train is the drive line, those components which carry the power and torque of the engine and transmission to the rear axle and thus to the rear wheels.

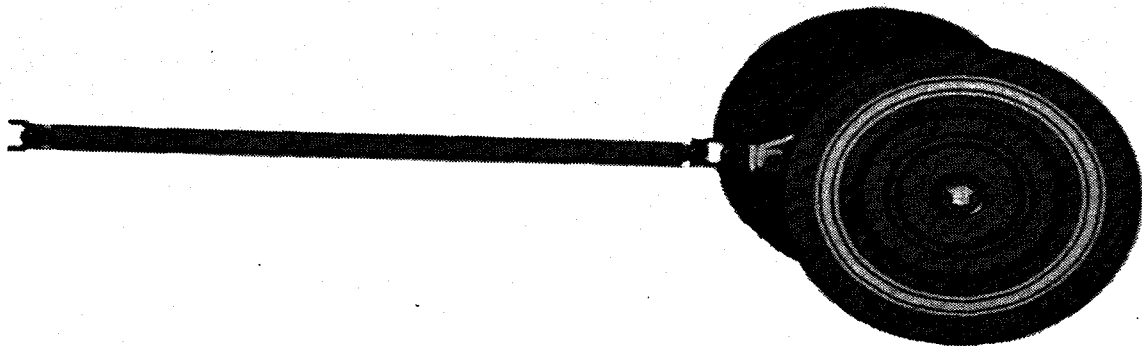

For 1965 there is a new, one-piece propeller shaft which transmits power from the transmission to the rear axle with utmost quietness and resistance to vibration. It contributes to the lower tunnel height in conjunction with the forward placement of the engine and transmission.

An exclusive feature is the use of CV (constant velocity) joints at each end of the prop shaft. CV joints cancel out forces that tend to set up vibrations or noise thus assuring a smoother, quieter drive line. Precise alignment of the propeller shaft and rear axle pinion through machine mounting attachments contributes to smoother, quieter performance and minimum vibration. The rear axle pinion seal is a two-lip design. The outer lip sealing out dirt, the inner lip sealing in lubricant, thus increasing durability and long life. Rear axle bearings for 1965 are pre-stressed for long lasting smoothness and dependability.

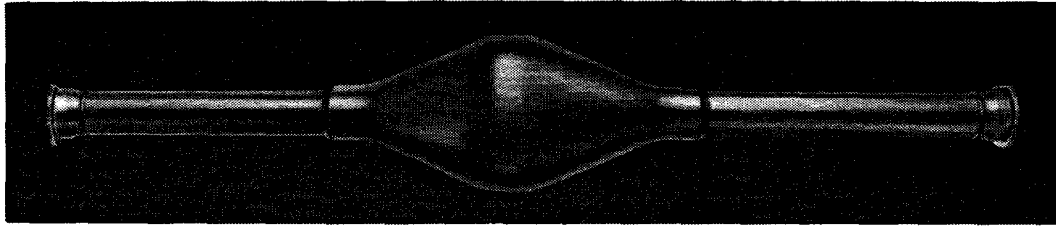

new rear axle housing

New rear axle housing for 1965 has a considerable reduction in number of pieces and reduced number and length of welds. The result is a much stronger and more rigid housing construction.

CV (constant velocity) joints

Each CV (constant velocity) joint used exclusively at both ends of the 1965 propeller shaft is in effect a unit of two U-joints, each serving to cancel out any vibration setting tendencies of the other for increased quietness and smoothness.

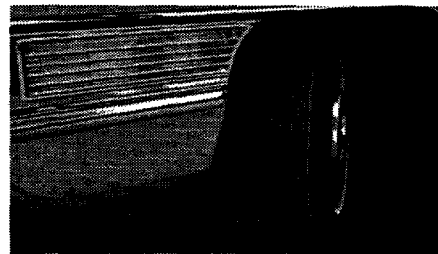
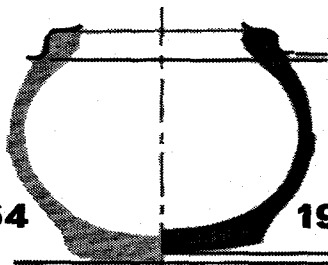
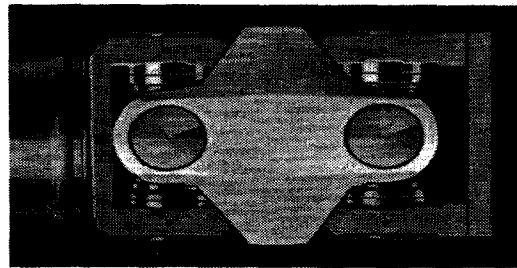

new tire tread and traction

Cadillac's new (optional at extra cost) whitewall tires for 1965 are wider in cross section but with a shorter diameter from road to wheel thus contributing to the lower height of the car. Adequate height for flexing of the sidewalls is maintained by a lower flange height on the wheel rim. In addition, tires have a new tread design extending around onto the shoulders for smoother transition in cornering. Tread pattern provides improved wet road traction. Among the benefits of the new tires are better directional feel and high speed durability, improved cornering and excellent quality of ride.

1965 Cadillac chassis

The new Cadillac chassis offers many important benefits certain to be enjoyed by 1965 Cadillac owners. For example, the forward mounting of the engine and transmission, which enabled a reduction in tunnel size and increased front passenger compartment space, was made possible by the new frame design. Engineering advancements to the front and rear suspension assure even greater riding comfort and roadability. Steering improvements mean better handling and stability. Even Cadillac's exclusive triple braking system has been further refined for 1965.

77

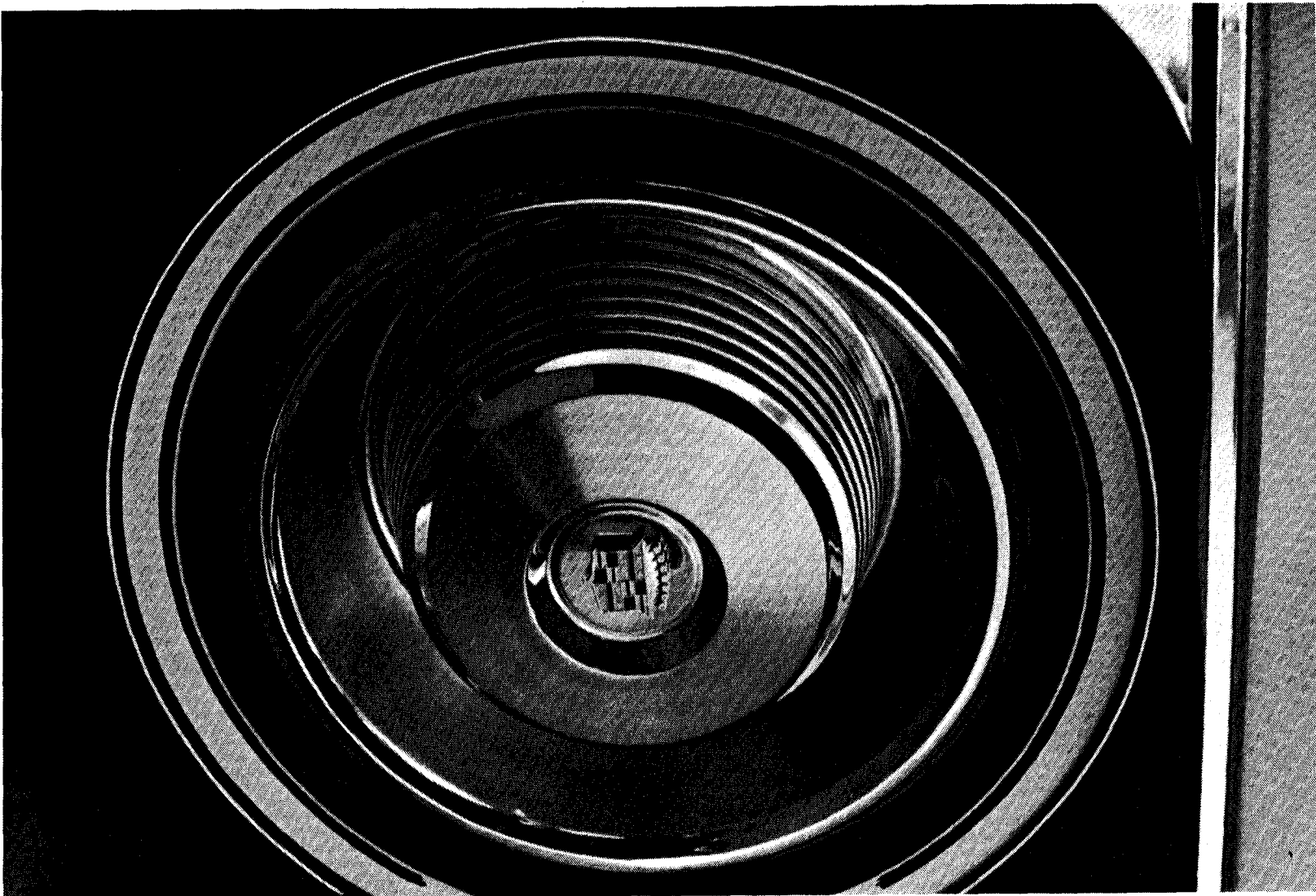

new Cadillac frame

1. The new Cadillac perimeter frame is fully boxed throughout its length for torsional rigidity and resistance to impact.
2. Hidden bulkheads contribute additional resistance to torsional stress . . . add to strength and rigidity.
3. New and unique pheasant-tail design of rear engine support crossmember permits engine support without infringing on front compartment driver and passenger floor space (as a straight crossmember would).
4. Increased width of new frame permits moving front suspension strut rods further outboard for better control of fore and aft movement of front wheels.
5. Design of frame with box-section side rails instead of central structure permits lower tunnel height in car interior.
6. New frame-to-body structure permits lowering step-in height by approximately one inch.

New larger suspension system bushings for greater quietness, improved cushioning and isolation of road noise or vibration.

New improved Turbo Hydra-Matic for increased performance, wider selectivity of acceleration, improved engine braking.

New plastic centering ring and deadener in transmission for maximum quietness especially in Drive range.

New location of coil springs on rear axle housing instead of lower control arms permits control arm bushings to better isolate road noise and cushion wheel impacts.

Improved steering linkage and sealing for smoother response and handling ease, greater dependability and long life.

CV (constant velocity) joints at each end of prop shaft assure maximum smoothness, quietness and durability.

Exclusive Cadillac shock absorbers maintain consistent quality of ride under most severe road conditions.

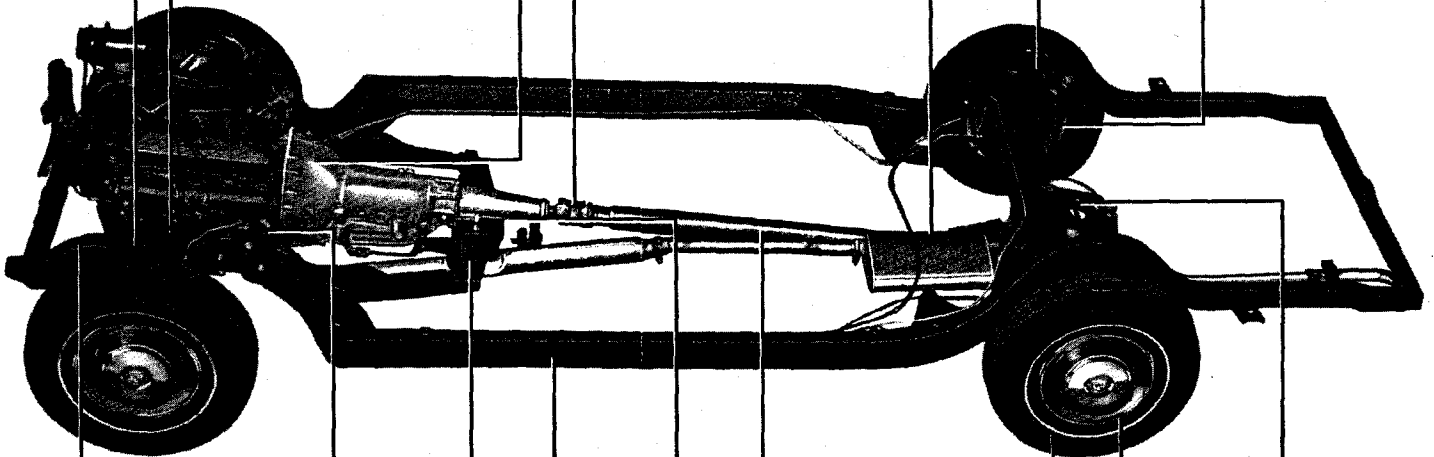

New front suspension strut rods mounted further outboard on frame crossmember for added stability and steering control.

New, longer pedal arm on emergency brake and improved mechanism for ease of application, added reliability.

New engine mountings precisely tuned to frame characteristics for maximum idling smoothness, quietness and stability.

New box-section perimeter frame with hidden bulkheads for torsional rigidity and strength.

New one-piece propeller shaft for quiet, vibration-resistant performance and lower floor tunnel height.

New whitewall tire and tread design for maximum quietness, improved traction, better cornering and high speed stability.

New perimeter frame design permits forward mounting of engine for lower tunnel height, increased passenger space.

New rear suspension minimizes deflection of rear of car on fast acceleration for increased comfort, level ride.

New pre-stressed rear axle bearings and races for greater dependability.

New more unified construction of rear axle housing for increased strength and rigidity.

Exclusive Cadillac Triple-Braking System provides independent front and rear systems plus true auxiliary or emergency braking.

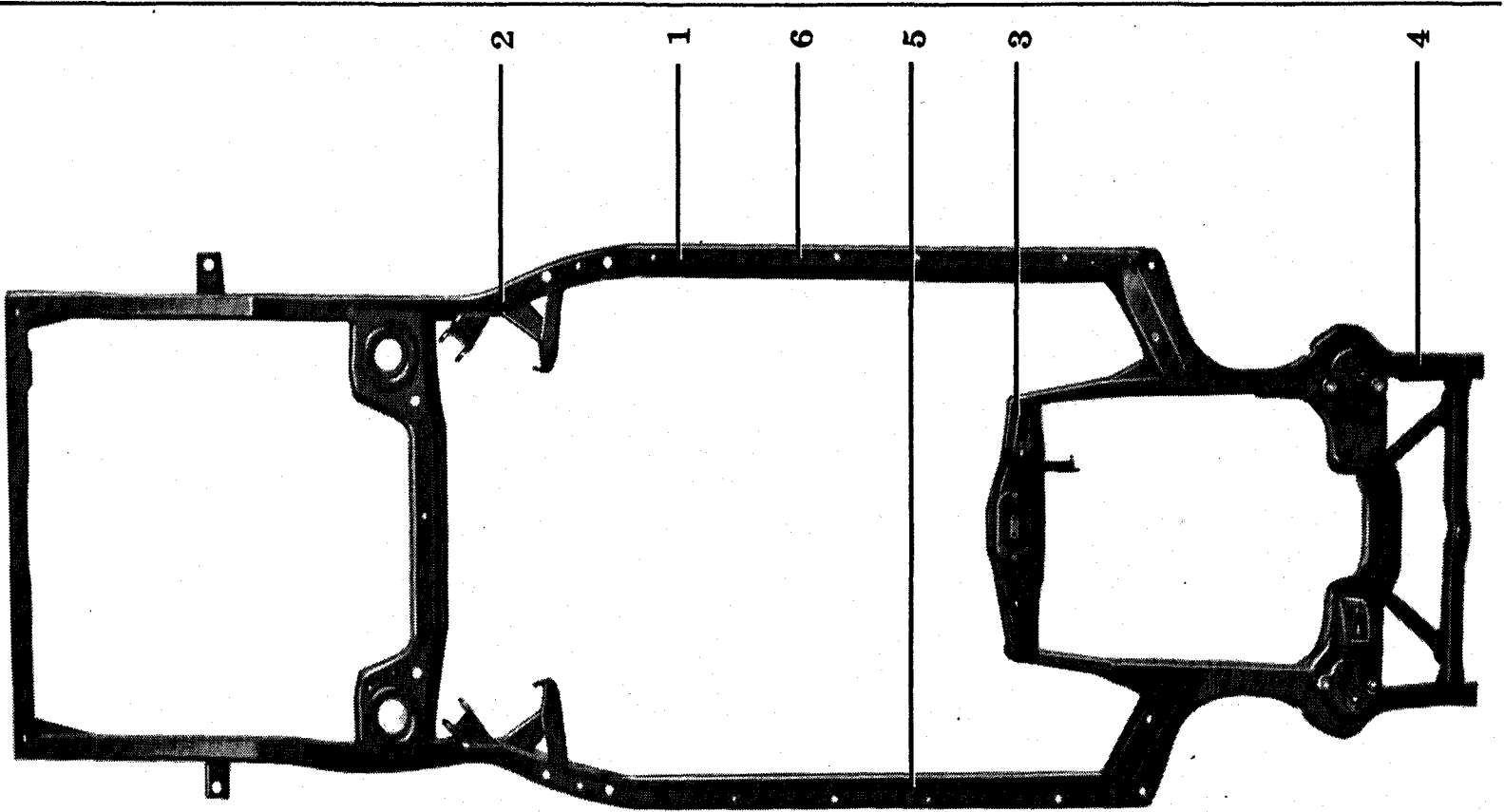

new front suspension



Improved stability and better control of fore and aft movement of the front wheels have been provided for 1965 by moving the front suspension strut rods further outward on the front frame crossmember. The strut rods, mounted to the frame through thick rubber bushings, hold the wheels in firm fore and aft alignment during normal driving yet permit a momentary rearward deflection of the wheel when it encounters a bump or depression in the road surface thus cushioning the impact. All other front suspension members are also mounted to the frame with rubber bushings designed to absorb or isolate road noise or shock. Rubber limit bumpers permit maximum vertical wheel travel . . . cushion the impact should "bottoming" ever occur.

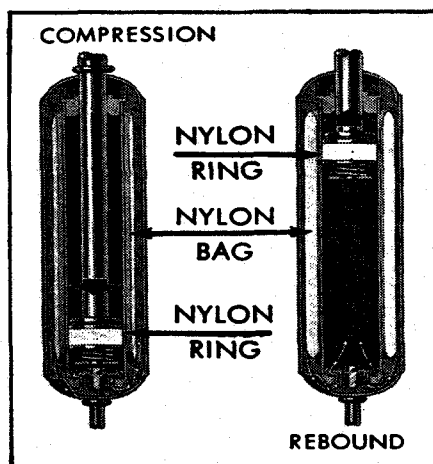

shock absorbers

Cadillac Shock Absorbers eliminate any mixing of air with shock absorber fluid by using a gas-filled nylon envelope to replace the air space in conventional shock absorbers. Fluid itself is impervious to temperature changes, retains efficiency in any weather.

new rear suspension

Cadillac Four-Link rear suspension for 1965 has the coil springs moved from the lower control arms to the rear axle housing. This removes the spring load on suspension bushings so they can more effectively do their job of isolating road noise. The lower control arms hold the axle in firm fore and aft alignment. New upper control arms offer increased resistance to sideways motion of the car. Mounted at one end on each side of the center of the rear axle housing, their opposite ends are mounted much further outward on the frame for 1965, thus providing added stability through a more widespread stance. The deflection of the rear of the car toward the road under fast acceleration has been reduced approximately two-thirds for 1965, a factor not only in added comfort but in making it possible to reduce the height of the rear floor tunnel. Oversize rubber bushings at upper and lower control arm mountings and thick insulators at top and bottom of springs absorb and isolate road noise.

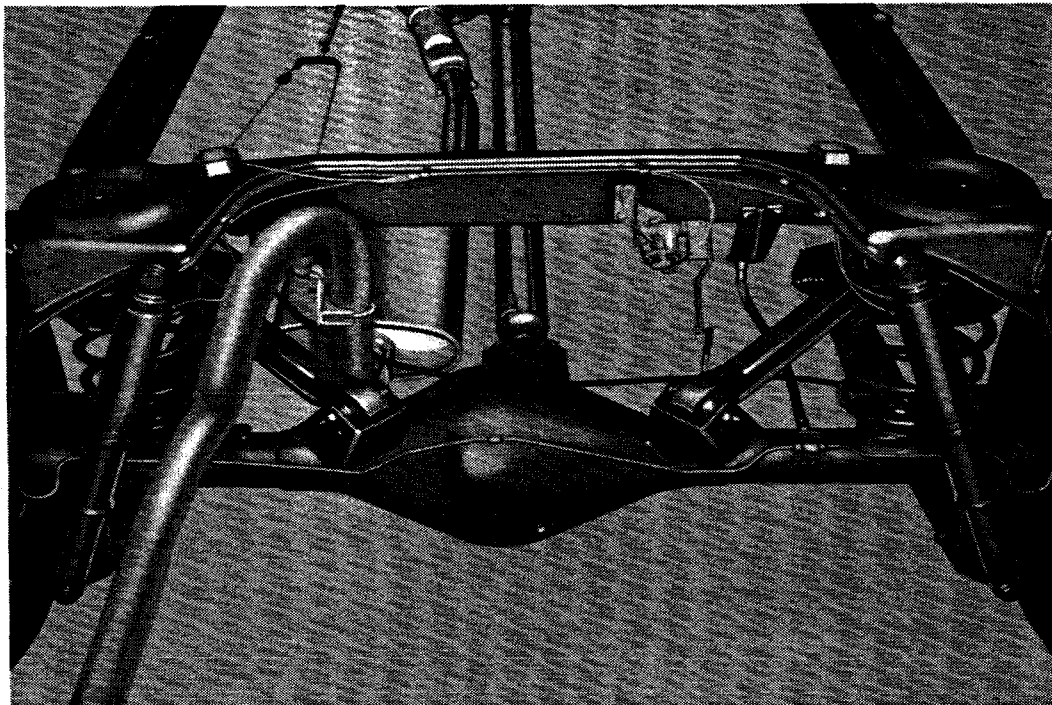

Cadillac power steering

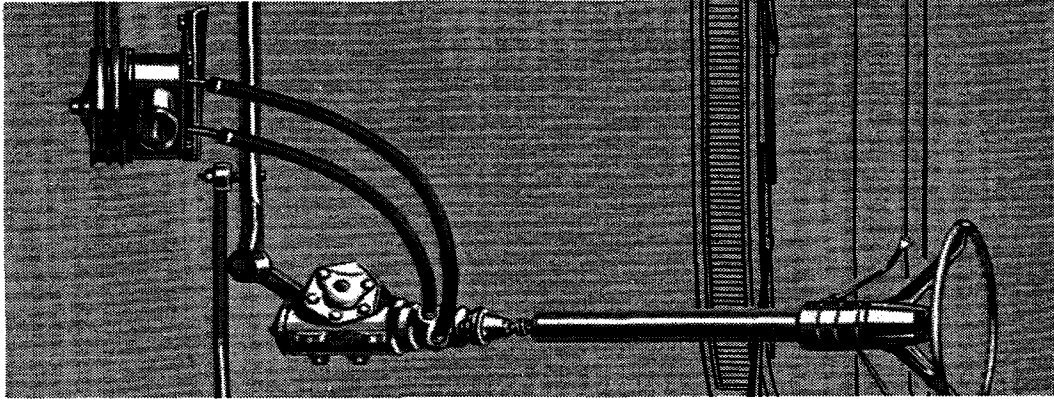

Only the lightest touch is required on the steering wheel, even in parking, with Cadillac Power Steering. And, of course, it continues to offer that important feel of the road essential in judging safe speeds around curves or on slippery roads. A rubber coupling in the steering shaft minimizes transmission of vibration or road shocks. Steering pump has simple turn cap to facilitate checking of the fluid level. Modifications to the steering linkage increase steering response and improve handling for 1965, while improved seals on linkage joints further assure the smooth, reliable performance of these parts.

additional steering advantages

Other factors which contribute to Cadillac's superior handling ease for 1965 are the wider front and rear tread, new tire tread design and new front and rear suspension features. While discussed individually elsewhere, the total effect of these advancements is improved steering response and directional stability, regardless of passenger or luggage compartment loads, quieter cornering and better control on all road surfaces including washboard roads.

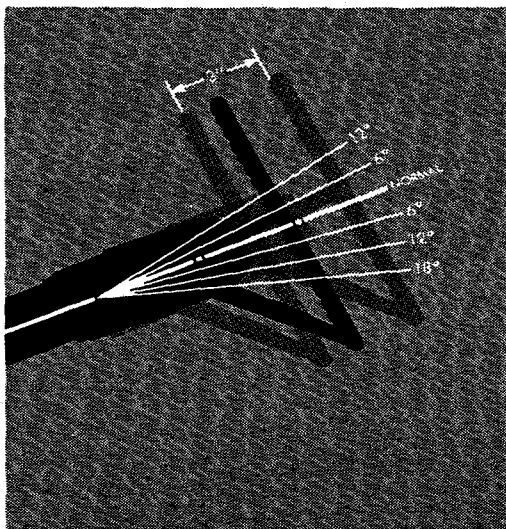

new tilt and telescope steering wheel

(See Optional Equipment Section)

The new Tilt and Telescope Steering Wheel permits adjusting the wheel upward or downward on the steering shaft over a 3-inch range. It also may be tilted to any of several positions to assure convenience and comfort for any driver.

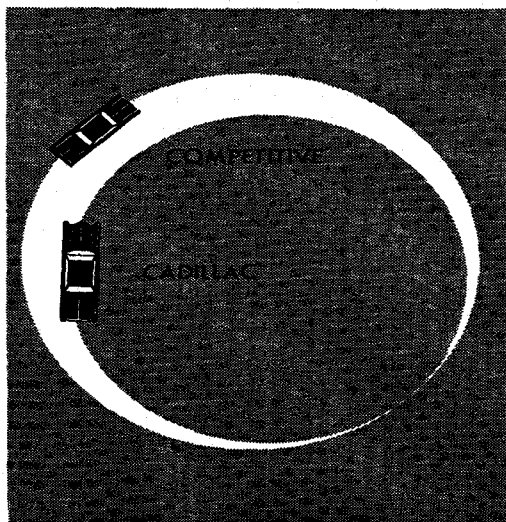

small turning diameter

With all of its new styling, impressive stature and major engineering advancements, Cadillac has retained the $38\frac{1}{2}^\circ$ front wheel turning angle which permits a maneuverability in parking or restricted areas no greater than that of many smaller cars.

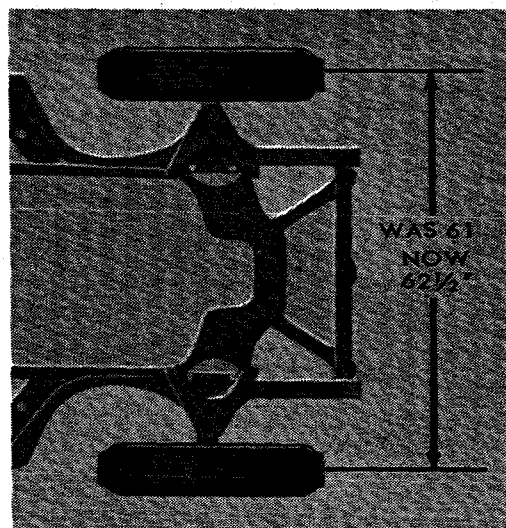

new wider tread

Now $62\frac{1}{2}$ inches, front and rear, Cadillac's new $1\frac{1}{2}$ " wider tread provides improved cornering and increased resistance to roll. Equal tread, front and rear, adds directional stability . . . minimizes swerve or dive effect when wheels run onto road shoulder or cross expansion joints in pavement.

**exclusive
Cadillac
triple braking
system**

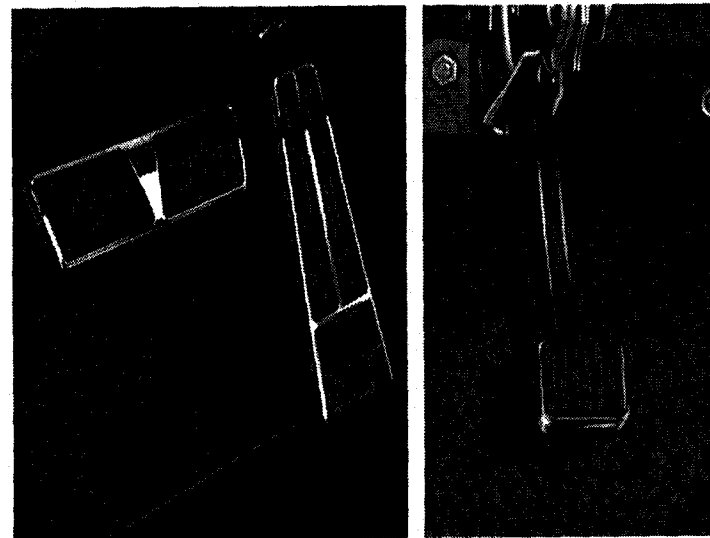
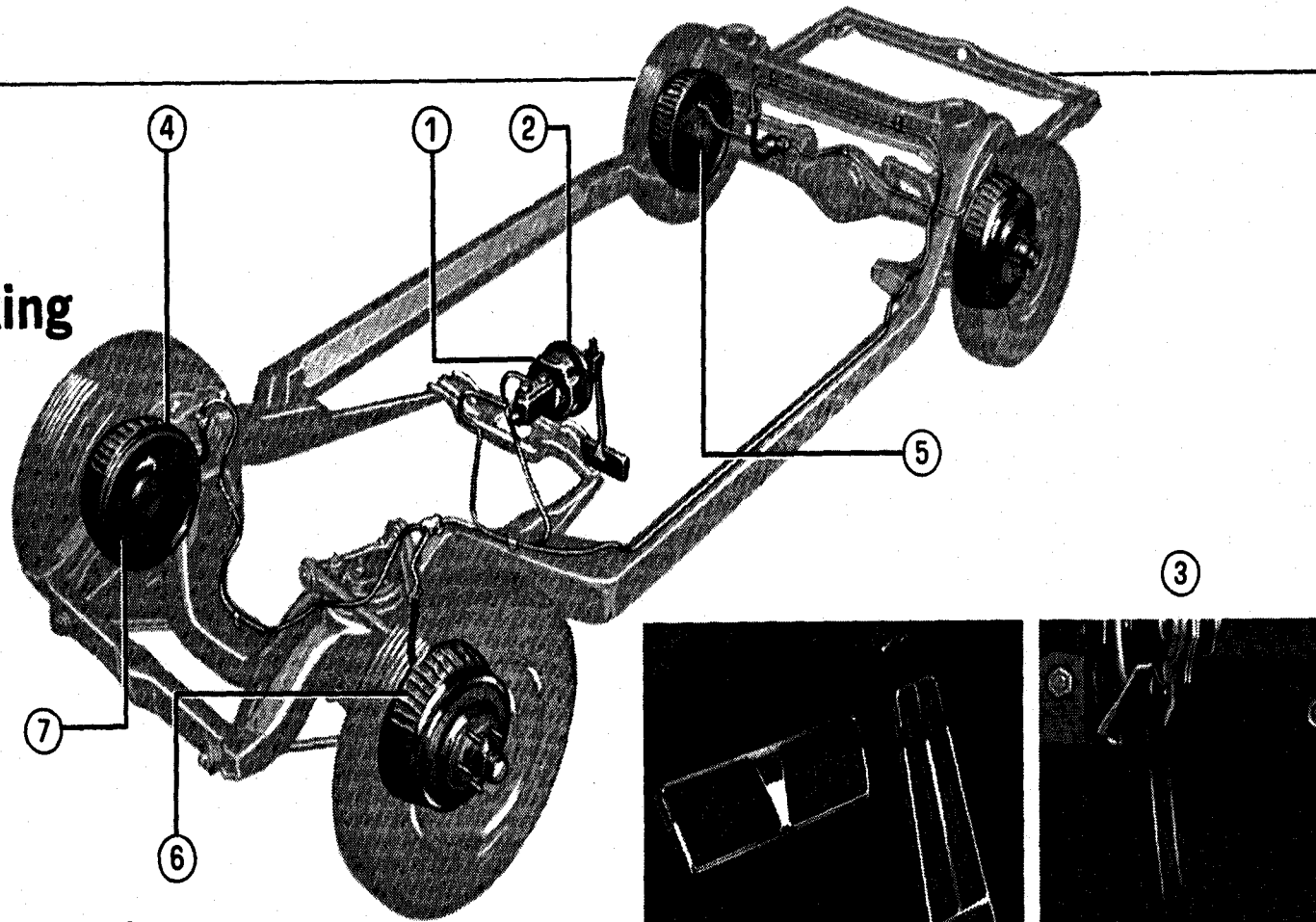

New depression in floor pan under brake pedal permits lower pedal height for faster more convenient pivoting of foot from accelerator to brake without reducing available brake pedal travel. Lower pedal also adds new convenience for left-foot brake application.

① **Cadillac's independent front and rear braking system**

The system has a separate fluid reservoir, master cylinder piston and hydraulic lines for the front and also for the rear brakes, thus assuring that one set works should the other become inoperative.

② **diaphragm seal in each brake reservoir**

Assures further dependability by sealing off the fluid from any contaminants such as water or dirt which might enter through the breather hole on reservoir cover.

③ **exclusive emergency and parking brake**

Serves as a true auxiliary braking system since a vacuum release prevents it from locking in applied position as long as engine is running and transmission is in any drive gear. Brake is automatically released when engine is started and transmission shifted into gear, thus eliminating this driver responsibility. Longer pedal arm and improved mechanism ease application and increase dependability for 1965.

④ **self-adjusting brake shoes**

Automatically bring linings back to proper clearance with drums when brakes are applied when car is being reversed, thus eliminating manual adjustment under normal conditions for life of lining.

⑤ **long-life pistons in wheel brake cylinders**

Made of a super-hard iron alloy instead of aluminum, are self-lubricated and provide extra long life and corrosion resistance.

⑥ **finned brake drums front and rear**

Provide increased area for cooling flow of air thus dissipating heat faster. Any possibility of brake fading or loss due to expansion of overheated drums is minimized.

⑦ **front brake splash protection**

It is provided by a specially designed flange on the front brake backing plates which shields interior of drums from splashing water.

1965 Cadillac body

The sleek styling and glamorous beauty of the Cadillac body is matched by construction features whose one basic purpose is to assure the Cadillac owner and his passengers maximum safety, comfort and convenience. At the same time, these features are a contributing factor to that enduring worth which assures the original and each subsequent owner maximum protection for his motor car investment.

The Fleetwood Plant of the Fisher Body Division is devoted exclusively to the manufacture of all Cadillac bodies under rigid Cadillac quality control standards.



**new ease of entry
and exit . . .
roomier interiors**

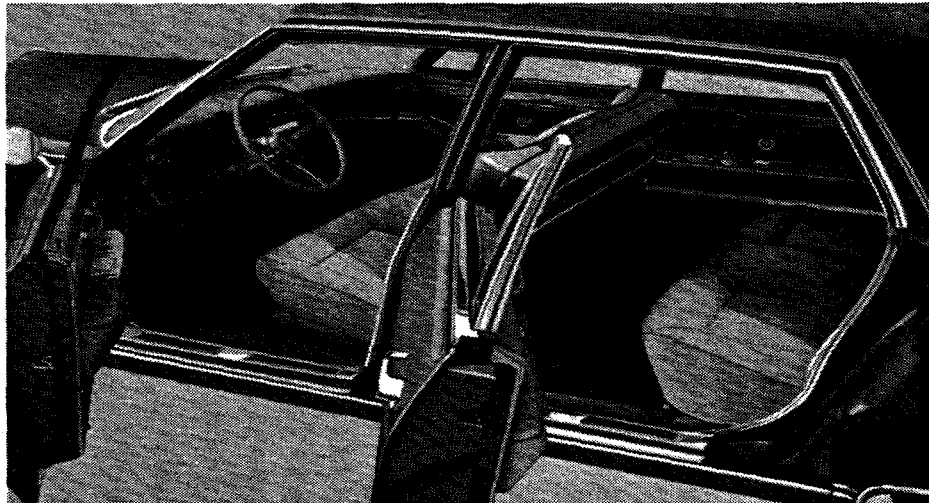

new lower door sills

The combination of low silhouette tires and new frame and body sill construction has resulted in lower door step-in height. Sills are also narrow thus minimizing hazards to formal gowns in wet or snowy weather.

wide opening, front hinged doors

Cadillac doors are hinged at the front and thus cannot be swept open by wind if accidentally opened with car moving. They open wide for unrestricted ease in entering or leaving the car.

new curved glass windows

The use of curved glass for door windows permits maximum interior width at the shoulder level. At the same time, its curved design requires less overhang of roof sides thus adding to convenience of entry and exit for 1965.

unrestricted entranceways

Absence of any windshield dogleg, slim steering wheel (which tilts up out of the way with the Tilt and Telescope feature, an extra-cost option) and rounded seat cushion corners all contribute to easier access to Cadillac's roomy interiors.

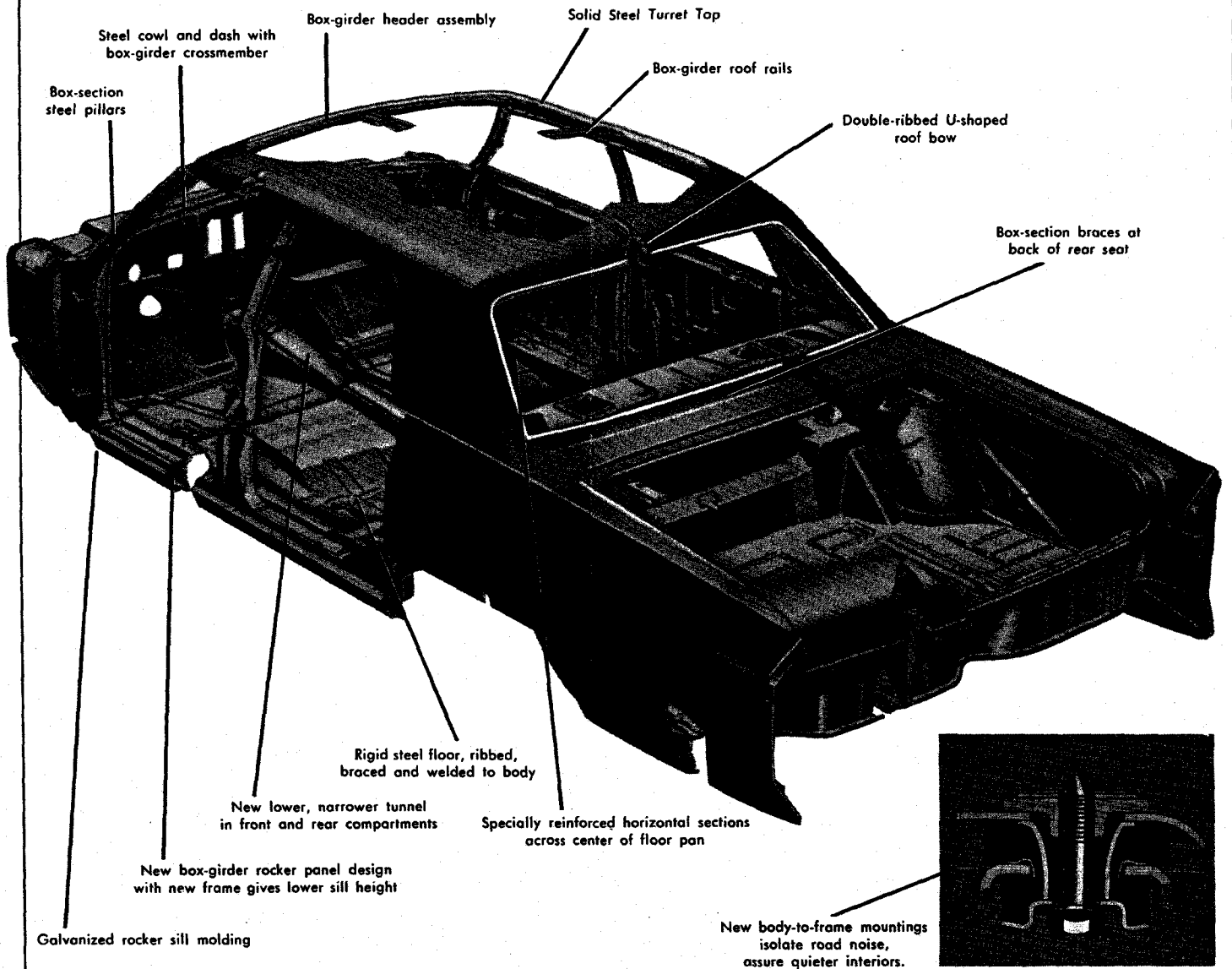

Steel cowl and dash with
box-girder crossmember

Box-girder header assembly

Solid Steel Turret Top

Box-girder roof rails

Double-ribbed U-shaped
roof bow

Box-section braces at
back of rear seat

Box-section
steel pillars

Rigid steel floor, ribbed,
braced and welded to body

New lower, narrower tunnel
in front and rear compartments

Specially reinforced horizontal sections
across center of floor pan

New box-girder rocker panel design
with new frame gives lower sill height

Galvanized rocker sill molding

New body-to-frame mountings
isolate road noise,
assure quieter interiors.

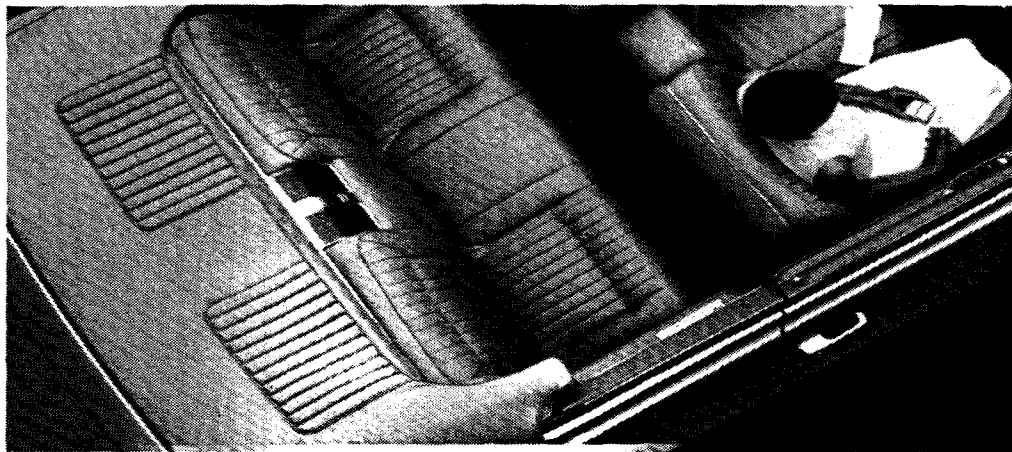

new convertible top boot

The open air motoring enthusiasts among Cadillac owners will find for 1965 a new convenience and new beauty in the top boot. It is made of a new stretchable plastic-coated fabric to assure a neat tailored appearance, and of even greater advantage, it has a new self-adhesive edging replacing the previous sliding channel mounting. Thus putting on or removing the top boot is faster and more convenient.

new double hood latch

Particularly pleasing to many Cadillac owners is the wide expanse of hood reaching from centerline to centerline of the front fenders. It is an even wider hood for 1965, and through the introduction of dual hood locks it becomes an actual functional part of the front end structure. A single fingertip release latch is located just to the right of the hood ornamentation and just above the grille.



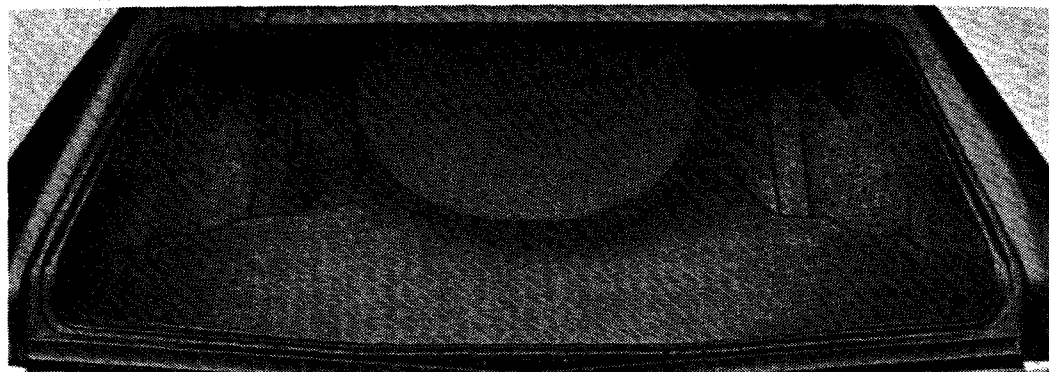

large luggage compartment capacity

The Cadillac luggage compartment has always provided a large capacity to accommodate all of the luggage normally carried on a trip with ample room for golf clubs, as well. For 1965, the spare tire is mounted in a sloping position on the shelf or kick-up (on all but convertible and Fleetwood Seventy-Five models) thus providing ample and more accessible luggage space. Luggage compartment is lined with tweed-textured, vinyl-coated fabric and has a rubber seal entirely around the deck lid opening for weather protection.

covered, non-protruding hinges

The use of deck lid hinges which disappear into housings or receptacles contributes to the finished appearance of the luggage compartment and protects fine luggage.

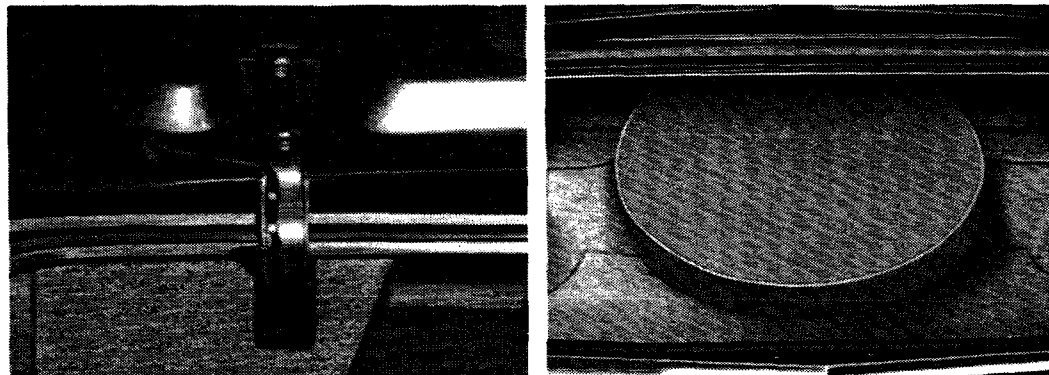

spare tire cover

Standard on the Fleetwood Sixty Special and Eldorado models and an extra-cost option on all others, the spare tire cover matches the luggage compartment lining. It not only protects luggage from soil and scuff marks, but serves to keep the whitewall area of the spare tire spotlessly clean.

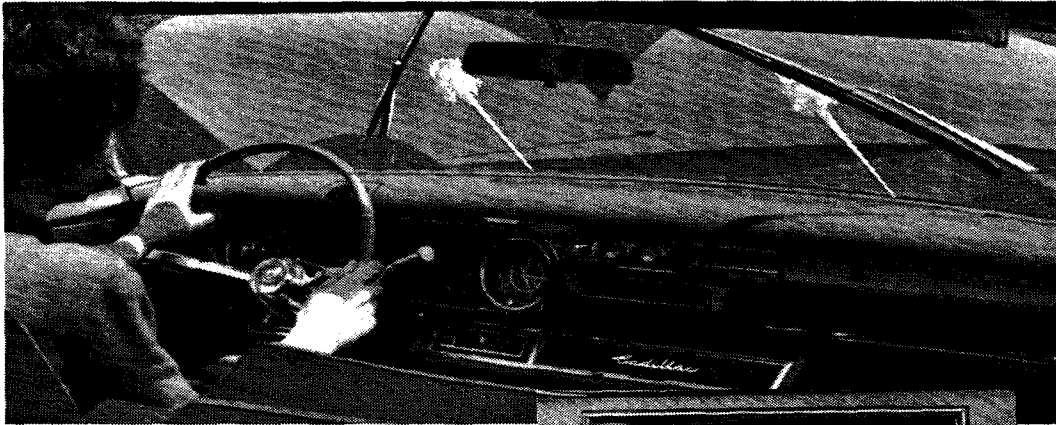

improved windshield washer-wipers

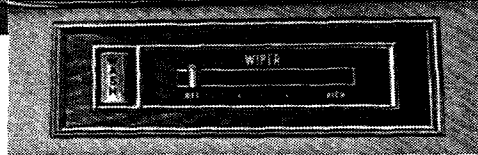

For 1965 Cadillac windshield washer-wipers provide new convenience and efficiency. The centerline of the operating arms have been moved outward thus providing an increased wiping area in front of the driver as well as the front compartment passenger. In addition, the three-speed operating switch and washer-wiper button are illuminated for added convenience in nighttime driving.

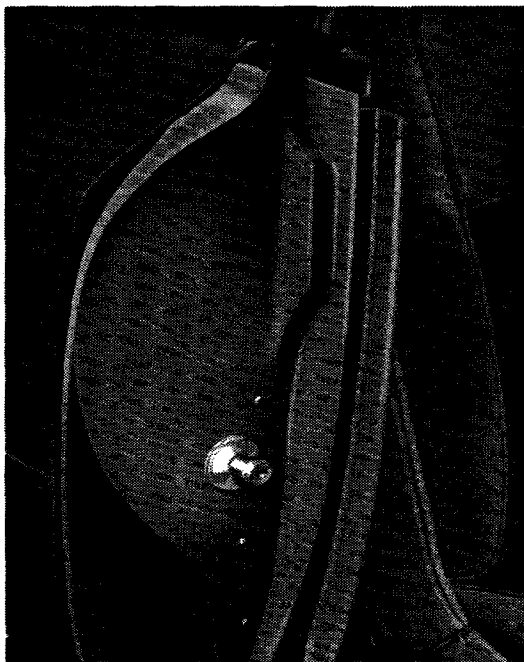

new door safety features

Cadillac's concern for the driver and his passengers is further emphasized for 1965 by new door locks. They are designed so that the locking bolt helps to retain the doors more tightly and securely and thus to prevent them from opening under impact. In addition, the new locks are quieter and smoother in operation.

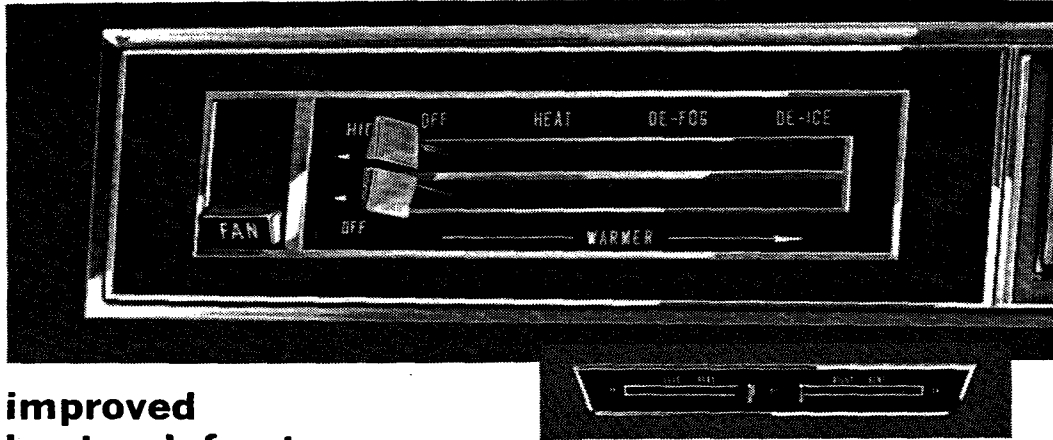

improved heater-defroster

(a deletion option at reduced cost)

new ventilation control accessibility

The Cadillac Heater-Defroster is provided as standard equipment but may be deleted at the owner's option at reduced cost. It provides a wide range of temperatures, quickly varied to meet the temperature desired by the driver through blending of heated and unheated air. For 1965, new, larger ducts are provided for the direction of air to the rear compartment thus adding to rear compartment passenger comfort. Upper lever of controls may be set at **HEAT** for warming car interior, or to **DE-FOG** or **DE-ICE** to direct air to the windshield as such conditions may require. Temperature of the air at any of these settings is determined by positioning the lower lever. Fan switch provides three blower speeds. Heater controls are newly located to the right of the steering column. Ventilation controls are centrally located for equal convenience of operation by the driver and front passenger.

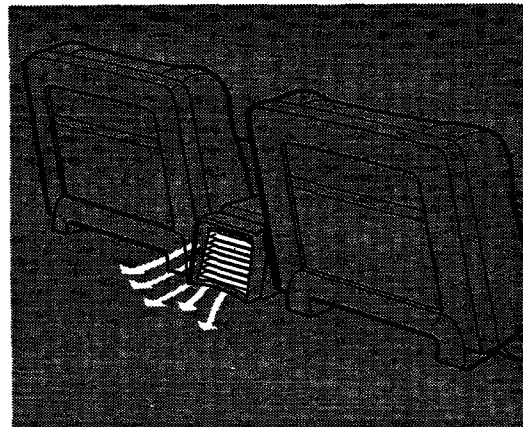
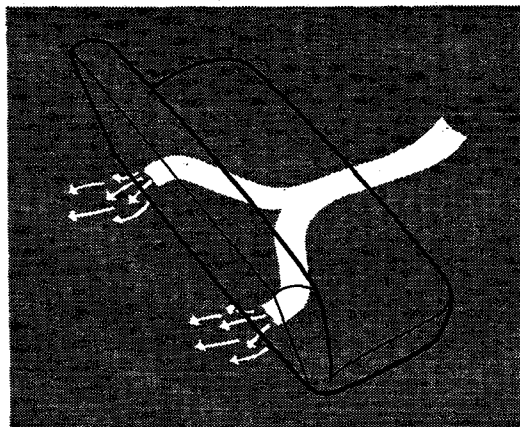

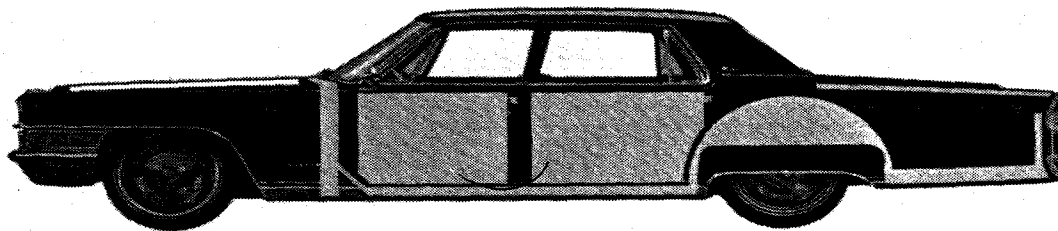

scientific soundproofing

The quietness of Cadillac interiors, a matter of pride and pleasure for Cadillac owners, is achieved through scientifically selected soundproofing. There is a sandwich-type sound barrier between engine and passenger compartments and sound deadening material at designated areas to absorb noise of tire-thrown gravel. Cadillac provides a highly efficient rubber compound sound barrier at each side of the cowl just forward of the car doors. This same barrier between two layers of jute just beneath the front compartment carpeting extends to the carpet-covered areas of the front compartment door sills. Rear compartments have two layers of jute topped by deep carpeting and, between the steel top and headlining of Calais, De Ville and Fleetwood Sixty Special models, there are layers of felt deadener and tuflex insulation. On the underside of the hood is a sound and heat-absorbing, vinyl-covered fiberglass pad 1 1/2" thick.

floor insulation

Protecting the front compartment against heat, cold, noise and drafts is a four-layer barrier of selected materials.

1. Jute
2. Rubber Compound
3. Jute
4. Carpeting

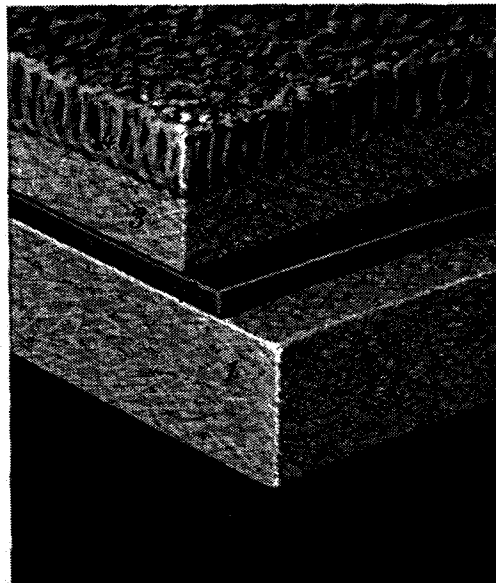

1965 Cadillac general specifications

94

	Calais Sedans and Sedans de Ville	De Ville Convertible, Coupe de Ville and Calais Coupe	Fleetwood Eldorado Convertible	Fleetwood 60 Special Sedan	Fleetwood 75 9-Passenger Sedan and Limousine
Wheelbase.....	129.5"	129.5"	129.5"	133"	149.8"
Over-all Length.....	224"	224"	224"	227.5"	243.8"
Over-all Width.....	79.9"	79.9"	79.9"	79.9"	79.9"
Over-all Height.....	55.6"†	54.6"	54.6"	55.9"	59.0"
Minimum Road Clearance.....	5.5"	5.5"††	5.6"	5.7"	6.2"
Steering Ratio—Over-all.....	18.2	18.2	18.2	18.2	18.2
Turning Diameter (Wall-to-Wall)..	47'9"	47'9"	47'9"	48'9"	52'
Tread—Front.....	62½"	62½"	62½"	62½"	61"
Tread—Rear.....	62½"	62½"	62½"	62½"	61"
Tires, Tubeless—Size.....	8.00 x 15*	8.00 x 15*	9.00 x 15	8.00 x 15*	8.20 x 15
Tires—Ply Rating.....	4-ply	4-ply	4-ply	4-ply	6-ply

*9.00 x 15 supplied in whitewall tires (standard on Fleetwood Eldorado).

†54.5" on hardtop sedans.
††5.6" on De Ville Convertible.

95

	Calais Sedans and Sedans de Ville	De Ville Convertible, Coupe de Ville and Calais Coupe	Fleetwood Eldorado Convertible	Fleetwood 60 Special Sedan	Fleetwood 75 9-Passenger Sedan and Limousine
Engine.....	340-horsepower Cadillac V-8	340-horsepower Cadillac V-8	340-horsepower Cadillac V-8	340-horsepower Cadillac V-8	340-horsepower Cadillac V-8
Compression Ratio.....	10.5:1	10.5:1	10.5:1	10.5:1	10.5:1
Piston Displacement.....	429 cu. in.	429 cu. in.	429 cu. in.	429 cu. in.	429 cu. in.
Valve Arrangement.....	Overhead	Overhead	Overhead	Overhead	Overhead
Carburetor.....	4-barrel	4-barrel	4-barrel	4-barrel	4-barrel
Exhaust System.....	Single	Single	Single	Single	Single
Transmission.....	Turbo Hydra-Matic	Turbo Hydra-Matic	Turbo Hydra-Matic	Turbo Hydra-Matic	Turbo Hydra-Matic
Steering.....	Hydraulic Power	Hydraulic Power	Hydraulic Power	Hydraulic Power	Hydraulic Power
Brakes.....	Power Brakes Dual System	Power Brakes Dual System	Power Brakes Dual System	Power Brakes Dual System	Power Brakes Dual System
Frame.....	Perimeter	Perimeter	Perimeter	Perimeter	Tubular-center X
Springs.....	Helical coil, front and rear	Helical coil, front and rear	Helical coil, front and rear	Helical coil, front and rear	Helical coil, front and rear
Drive.....	Cadillac Four-Link	Cadillac Four-Link	Cadillac Four-Link	Cadillac Four-Link	Cadillac Four-Link
Axle Ratio.....	2.94:1*	2.94:1*	2.94:1*	2.94:1*	3.36:1**

*3.21 optional; standard with air-conditioned cars.

**3.77 optional on Fleetwood 75.

detailed specifications

engine

Number of cylinders.....	8
Cylinder arrangement.....	90° V-type
Valve arrangement.....	Overhead
Bore and stroke.....	4.13" x 4.0"
Block and cylinder head material.....	Cast iron
Piston displacement.....	429 cu. in.
Taxable horsepower.....	54.6
Max. brake horsepower.....	340 @ 4600 r.p.m.
Max. engine torque—lbs.-ft....	480 @ 3000 r.p.m.
Compression ratio.....	10.5:1
Engine mounts.....	Vulcanized rubber
Number of points of suspension	3

pistons and rings

Make.....	Central Foundry— Zollner-Sterling
Material.....	Aluminum alloy
Type.....	T-slot cam ground
Weight.....	20.0 oz.
Clearance.....	.0008-.0012"
Number of oil rings per piston.	1
Number of comp. rings per piston.....	2
Top compression ring.....	Molybdenum filled

rods and pins

Wristpin length	3.093"
Wristpin material	Steel
Type	Locked in rod
Connecting rod length	6.500"
Material—connecting rod	Forged steel
Weight—connecting rod	19.36 oz.
Lower bearing material	Steel-back Moraine
Connecting rod bearing clearance0005"-.0021"
Connecting rod bearing end play008"-.014" (total two rods)

crankshaft

Material	Pearlitic malleable iron
Weight	59 pounds
Main bearing thrust	Center main
Crankshaft end play001" to .007"
Main bearing removable	Yes
Main bearing material	Steel-back Moraine
Main bearing clearance—rear0006" to .003"
Main bearing journal— Diameter x Length:	
Number 1	3.000" x 1.120"
Number 2	3.000" x 1.062"
Number 3	3.000" x 1.138"
Number 4	3.000" x 1.062"
Number 5	3.000" x 1.120"

detailed specifications

camshaft

Drive.....	Chain
Camshaft sprocket material...	Aluminum with nylon teeth
Timing chain—make.....	Link Belt
Timing chain—no. of links....	46
Timing chain—width.....	.6875"
Timing chain—pitch.....	.500"

valves

Valve arrangement.....	Overhead
Intake opens.....	34° B.T.C. at .001 lift
Intake closes.....	102° A.B.C. at .001 lift
Exhaust opens.....	89° B.B.C. at .001 lift
Exhaust closes.....	63° A.T.C. at .001 lift

intake

Material.....	Alloy steel
Over-all length.....	4.794"
Diameter of head.....	1.875"
Angle of seat.....	44°
Lift.....	.427"

exhaust

Material.....	Alloy steel
Over-all length.....	4.815"
Diameter of head.....	1.500"
Angle of seat.....	44°
Lift.....	.466"
Hydraulic valve lifters.....	Yes
Valve inserts.....	None
Valve seats cooled by.....	Direct water circulation

lubrication

Type	Full pressure
Oil under pressure to:	
Main bearings	Yes
Connecting rods	Yes
Wristpins	Splash
Camshaft bearings	Yes
Tappets	Yes
Oil pump type	Gear
Normal oil pressure	30 to 35 lbs. @ 30 m.p.h.
Capacity of oil reservoir	5 qts. with filter. Refill, 4 qts.
Type of oil level gauge	Dip stick
Make of pressure gauge	AC—Tell-Tale Lite
Oil filter	Standard
Type	Full-Flow

fuel

Gasoline tank capacity	26 gallons
Type of fuel feed	Camshaft pump
Carburetor—make	Rochester & Carter
Carburetor—type	Four-barrel downdraft
Manifold heat control	Automatic
Type of air cleaner	Dry-pack

cooling

Water pump type	Centrifugal—dual outlet
Pressure relief valve	Yes
Choke for recirculation	Yes
Radiator core	Cross-flow
Full length cylinder	
water jacket	Yes
Water all around cylinders	Yes

detailed specifications

cooling—continued

		<u>Fleetwood 75</u>
Fan belt length:		
Generator	38.08"	53.10"
Steering pump	49.94"	50.62"
Fan belt width	$\frac{3}{8}$ "	
Fan blade material	Steel	
Fan—no. of blades	7	
Cooling system capacity	18.1 qts.	19.5 qts.
	Add 1 qt. for A/C	

generator

Make	Delco-Remy
Minimum charging speed	At idle
Generator ventilation	Forced air

generator regulator

Make	Delco-Remy
Voltage regulator setting	13.8-14.8 @ 100° (adjust to 14.2)
Generator max. charging rate	42 amp.
(Fleetwood 75 and air-conditioned cars)	55 amp.

starting motor

Make	Delco-Remy
Flywheel teeth, integral or ring	Steel integral

ignition

Spark advance	Centrifugal and vacuum
Ignition unit—make	Delco-Remy
Manual advance	None
Maximum centrifugal advance	Crankshaft (16°-20°)
Vacuum advance	Crankshaft (19°-21.5°)
Distributor breaker gap016"
Initial spark advance	5° B.T.C. (Nominal)
Firing order	1-8-7-2-6-5-4-3
Ignition coil—make	Delco-Remy
Spark Plugs:	
Make	AC
Model	44.0
Thread	14 mm.
Gap035"

battery

Make	Delco
Number of plates	13
Capacity (amp. hrs.)	73
Terminal grounded	Negative
Location of battery	Under hood on tray at front right-hand side of radiator cradle

lights and horn

Headlight—make	Guide sealed-beam (Dual)
Headlight cover glass, dia.	5 ³ / ₄ "
Parking light—make	Guide
Taillight—make	Guide
Lighting switch—make	Delco-Remy
How are headlights dimmed?	Depressed beam— foot switch
Cornering light	Guide-activated by directionals & light switch
Horn:	
Make	Delco-Remy
Type	Vibrator, seashell electric (2), trumpet high C (1)*

*Large trumpet low C, on Eldorado.

detailed specifications

**turbo
hydra-matic
transmission**

Type	Fully automatic torque converter combined with step gear shifts and variable stator.*
Gearing	Planetary
No. of forward speeds in left DRIVE position**	3
No. of forward speeds in right DRIVE position	2
No. of forward speeds in (L) low position	1

*Fixed stator on Fleetwood 75 models.
**Single DRIVE position only on Fleetwood 75 models.

Transmission ratio	
Low gear	2.48 plus torque converter
Intermediate gear	1.48 plus torque converter
High gear	1.00 plus torque converter
Reverse	2.07 plus torque converter
Torque converter maximum torque multiplication at stall	
	2.00

Oil capacity

		<u>Fleetwood 75</u>
Completely dry transmission	11 qts. 6 oz.	9 qts. 29 oz.
Pan drained by filler tube only	4 qts. 20 oz.	3 qts. 28 oz.
Pan and strainer removed ..	5 qts.	4 qts. 2 oz.

frame

		<u>Fleetwood 75</u>
Frame—make.....	A. O. Smith	A. O. Smith
Frame—type.....	Perimeter	Tubular- center X frame

front suspension

Front suspension—make.....	Own
Front suspension—type.....	Forked arms, upper. Single arms with tension strut rods, lower.
Control arm pivots.....	Rubber bushings
Knuckle support bearing.....	Spherical
Front wheel inner bearing.....	Tapered roller
Front wheel outer bearing.....	Tapered roller
Front spring—type.....	Helical coil
Front spring, material.....	Spring steel
Shock absorber—type.....	Hydraulic direct-acting type
Front stabilizer.....	Torsion rod

rear suspension

Type.....	Cadillac four-link
Yoke and control arm pivots..	Rubber bushings
Springs.....	Helical coil
Material.....	Spring steel
Shock absorbers.....	Hydraulic direct-acting, inverted "V" mounting

detailed specifications

propeller shaft

		<u>Fleetwood 75</u>
Type.....	1-piece	2-piece
Make.....	Saginaw	
Drive and torque taken through.....	Four-link rear suspension	
Universal Joints		
Number used.....	2	3
Type.....	Constant Velocity	Cross and cup
Universal joints, lubricated...	Permanently	

rear axle

Rear axle—make.....	Own	
Rear axle—type.....	Semifloating	
Differential gear—make.....	Own	
Rear axle:		
Oil capacity.....	5 pints	
Grade recommended:		
S.A.E. viscosity.....	90 hypoid	
		<u>Fleetwood 75</u>
Type of final gearing.....	Hypoid	
Gear ratio:		
Standard.....	2.94	3.36
Optional.....	3.21*	3.77
Rear wheel bearing—type....	Ball, grease-packed (permanent)	

*Standard on air-conditioned models.

tires and wheels

Tires:		
Make.....	U. S. Royal, Firestone, Goodrich and Goodyear	
Type.....	Tubeless	
		Fleetwood 75
Size.....	8.00 x 15*	8.20 x 15
Ply rating.....	4	6
Inflation pressure:		
Front.....	24 lbs.	28 lbs.
Rear.....	24 lbs.	28 lbs.
Wheels:		
Type.....	Slotted disc	
Make.....	Kelsey-Hayes	
Rim, diameter.....	15"	
Tread:		
Front.....	62 1/2"	61"
Rear.....	62 1/2"	61"
*9.00 x 15 when whitewalls are ordered. Standard on Fleetwood Eldorado.		

steering

		Fleetwood 75
Steering.....	Hydraulic power	
Type.....	Concentric gear	
Make.....	Saginaw	
Over-all steering ratio.....	18.2 to 1	
Car turning radius		
(wall-to-wall).....	23'10 1/2"	25'5"
Fleetwood 60 Special.....	24'4 1/2"	

detailed specifications

brakes

Front.....	Independent hydraulic
Rear.....	Independent hydraulic
Type.....	Duo-servo, self-adjusting
Brake drum diameter.....	12"
Brake drum, internal or external.....	Internal
Brake lining, length per wheel:	
Forward shoe.....	10.93"
Reverse shoe.....	12.44"
Total.....	23.37"
Brake lining width.....	2½"
Brake shoe clearance**.....	.010"—.030"
Foot emergency brake location	Left side below dash
Release.....	Automatic vacuum* plus manual
Operates on.....	Rear service brakes
Power brakes.....	Standard, all models

*With engine running and car in any drive gear.

**Controlled by self-adjusting linkage.

miscellaneous specifications

Fleetwood 75

Car lifting device, jack.....	Bumper type.	Scissor type
Engine lubrication—type.....	Pressure	
Chassis lubrication—type.....	No lube fittings	
Axle lubrication—type.....	Splash	

Lubricants

- Engine crankcase capacity.... 4 qts.
With oil filter (Std.)..... 5 qts.
Recommended viscosity.... Anticipated temperature:
+32°F or higher,
SAE-10W-30, SAE 20,
SAE 20W
0°F to +32°F,
SAE 10W, SAE 5W-20
0°F or lower,
SAE 5W, SAE 5W-20
- Drain..... 6000 miles
- CAUTION:** Drain more frequently in accordance with
Owner's Manual under varying operating conditions.
- Rear axle oil..... 5 pints
Recommended viscosity.... 90 hypoid
- Transmission fluid..... Type "A" (Suffix "A")
Turbo Hydra-Matic refill*.. 11 qts. 6 ozs. (completely
dry)
4 qts. 20 ozs. (pan drained
by filler tube only)
5 qts. (with pan and strainer
removed)
- Gasoline tank capacity..... 26 gallons

*Fleetwood 75

- 9 qts. 29 ozs. (completely
dry)
3 qts. 28 ozs. (pan drained
by filler tube only)
4 qts. 2 ozs. (with pan and
strainer removed)

1902-1964 Cadillac milestones

Cadillac has pioneered in the development of many motoring achievements . . . advancements in engineering and design which have set the trend for other motor car makers in the course of the ensuing years. The "milestones" listed in this section of your Data Book point up the dramatic year-by-year development of and increased demand for the Cadillac automobile, recognized and respected everywhere as the "Standard of the World." Milestones for 1964 include the introduction of Comfort Control . . . first fully automatic year 'round car air conditioning-heating system. And in 1964 Cadillac completes a multi-million dollar expansion program including a new engineering center, enlarged manufacturing and assembly space, multi-level parking facility, complete rebuilding of the administration building, and conversion of present engineering facility to manufacturing space.

Model Year	Total Production	Type of Cars Produced	List Price (Typical Car)	Wheelbase	Milestones
1902 } 1903 }	2,500	1 cyl. "A"	\$ 850	76"	Detroit Automobile Co., established 1899, reorganized as "Cadillac Automobile Co."
1904	2,318	1 cyl. "B"	950	76"	Cadillac Automobile Co. and Leland & Faulconer consolidate as "Cadillac Motor Car Company" with Henry M. Leland, grand old man of the industry, as General Manager.
1905	4,182	{ 1 cyl. "F" 4 cyl. "D"	950 2,800	76" 100"	First four-cylinder establishes Cadillac as the pioneer of multi-cylinder motor cars.
1906	4,307	{ 1 cyl. "M" 4 cyl. "H"	950 2,500	76" 102"	
1907	2,696	{ 1 cyl. "M" 4 cyl. "G" 4 cyl. "H"	950 2,000 2,500	76" 100" 102"	Famous Johansson gauges, First imported into United States by Cadillac, enable Cadillac to become the following year the—
1908	2,012	{ 1 cyl. "T" 4 cyl. "H"	1,000 2,500	82" 102"	First American car to be awarded the Dewar Trophy by Royal Automobile Club of London for being First to achieve interchangeability through standardization of parts.
1909	5,902	4 cyl. "30"	1,400	106"	Cadillac purchased by General Motors Corporation. Four-cylinder production increases six times over 1908 production.
1910	8,006	4 cyl. "30"	1,600	106"	First to offer Closed Bodies as standard equipment. Less than 10% of cars then produced had closed bodies.
1911	10,018	4 cyl. "30"	1,800	116"	Custom Coachcraft by Fleetwood Body Company begins.
1912	13,994	4 cyl. "1912"	3,250	116"	First to equip cars with Electric Starting, Lighting, Ignition, for which Cadillac again was awarded the Dewar Trophy. First and only car in the world to win this award twice.
1913	15,017	4 cyl. "1913"	3,250	120"	

Model Year	Total Production	Type of Cars Produced	List Price (Typical Car)	Wheelbase	Milestones
1914	14,002	4 cyl. "1914"	\$2,800	120"	World's First V-type , eight-cylinder engine reproducible in quantity as a result of Cadillac's pioneering efforts in standardization. The techniques of using interchangeable parts are referred to above in winning the Dewar trophy. The soundness of this record is evident in the uninterrupted use of this basic engine design, which was the prototype of many engines used throughout the industry.
1915	13,001	V-8 "51"	2,800	120"	First to use Tilt-Beam Headlights for night driving safety.
1916	18,003	V-8 "53"	2,950	122"	Cadillac becomes "Division of General Motors."
1917	18,002	V-8 "55"	3,110	125"	Cadillac adopted as Standard Officers' car by U. S. Army after grueling tests at Marfa, Texas.
1918	20,285	V-8 "57"	3,535	125"	Cadillac supplied 2,350 cars and 1,157 V-8 artillery tractor engines to U. S. Army.
1919	20,678	V-8 "57"	4,090	125"	
1920	19,628	V-8 "59"	4,750	125"	Cadillac completes new Clark Ave., Detroit, plant, most modern in the industry.
1921	5,250	V-8 "59"	4,950	132"	
1922	26,296	V-8 "61"	4,100	132"	First to use Thermostatic Carburetor Control.
1923	14,707	V-8 "61"	4,150	138"	First to build the inherently balanced 90° V-type eight-cylinder engine. First to use the Compensated Crankshaft. Four-wheel brakes featured.
1924	18,827	V-8 "63"	3,835	132"	First to provide wide choice of Duco Exterior Finishes as standard equipment.
1925	16,673	V-8 "63"	3,195	132"	First to use Crankcase Ventilation. \$5,000,000 expansion program started. Cadillac contracts for entire output of Fleetwood Custom Body Co.
1926	20,419	V-8 "314"	3,250	132"	First to develop a comprehensive Service Policy and place it on a nationwide basis.
1927	47,420	V-8 "303"	2,685"	125"	
		V-8 "314"	3,250	132"	

1928	29,572	V-8 "303"	\$2,685	125"	First to develop and use the Clashless Synchro-Mesh Transmission. First to install Security Plate Glass as standard equipment.
		V-8 "341-A"	3,250	140"	
1929	40,965	V-8 "328"	2,495	125"	First to adopt Chrome Plating as standard.
		V-8 "341-B"	3,595	140"	
1930	25,991	V-8 "340"	2,565	134"	First to build a Sixteen-Cylinder Automobile Engine. Later in the year, the V-12 Cadillac was introduced. First to offer a complete line of multi-cylinder cars—all of V-type design.
		V-8 "353"	3,695	140"	
1931	29,781	V-8 "345-A"	2,295	134"	First to use Hydraulic Valve Silencers.
		V-8 "355-A"	2,795	134"	
		V-12 "370-A"	3,895	140"	
		V-16 "452-A"	5,950	148"	
1932	8,085	V-8 "345-B"	2,495	136"	First to introduce Super-Safe Headlights, Air-Cooled Generator, Completely Silent Transmission and Full-Range Ride Regulator.
		V-8 "355-B"	3,095	140"	
		V-12 "370-B"	3,795	140"	
		V-16 "452-B"	5,095	149"	
1933	6,654	V-8 "345-C"	2,245	136"	First to provide fine cars with No-Draft Ventilation.
		V-8 "355-C"	2,895	140"	
		V-12 "370-C"	3,595	140"	
		V-16 "452-C"	6,250	149"	
1934	11,856	Str.-8 "50"	1,595	119"	First to introduce today's mode of streamlining. First American car with spare tire concealed within body. First to develop and use Knee-Action Wheels.
		V-8 "10"	2,495	128"	
		V-8 "20"	2,695	136"	
		V-8 "30"	3,295	146"	
		V-12 "40"	3,995	146"	
		V-16 "60"	6,650	154"	
1935	13,449	Str.-8 "50"	1,545	119"	First and Only fine car equipped with one-piece solid steel Turret Top. For five years, more Cadillacs purchased than any other make of fine car.
		V-8 "10"	2,445	128"	
		V-8 "20"	2,645	136"	
		V-8 "30"	3,295	146"	
		V-12 "40"	3,995	146"	
		V-16 "60"	6,750	154"	

Model Year	Total Production	Type of Cars Produced	List Price (Typical Car)	Wheelbase	Milestones
1936	25,905	Str.-8 "50"	\$1,225	120"	48.1% of all cars sold above \$1,500 were Cadillacs.
		V-8 "60"	1,695	121"	
		V-8 "70"	2,445	131"	
		V-8 "75"	2,645	138"	
		V-12 "80"	3,195	131"	
		V-12 "85"	3,345	138"	
		V-16 "90"	7,570	154"	
1937	46,153	V-8 "37-50"	1,260*	124"	Cadillac-built V-8 proves stamina, dependability and speed of present day stock car by breaking all previous stock car records at Indianapolis Speedway. Deliveries at retail hit all-time peak in previous Cadillac history.
		V-8 "37-60"	1,660*	124"	
		V-8 "37-65"	2,090*	131"	
		V-8 "37-70"	2,595*	131"	
		V-8 "37-75"	2,815*	138"	
		V-12 "37-85"	3,535*	138"	
		V-16 "37-90"	7,750*	154"	
1938	24,950	V-8 "38-50"	1,385*	124"	First to create and introduce a practical motor car of advanced styling. First to engineer and build the 135° V-type sixteen-cylinder engine. A majority public recognition of Cadillac Merit and Advanced Progress is definitely established.
		V-8 "38-60"	1,775*	124"	
		V-8 "38-60S"	2,085*	126"	
		V-8 "38-65"	2,285*	132"	
		V-8 "38-75"	3,075*	141"	
		V-16 "38-90"	5,265*	141"	
1939	36,611	V-8 "39-50"	1,320*	120"	First to develop and introduce Controlled-Action, greatest advancement in riding comfort and safety since Knee-Action. More than half of all fine cars sold above \$2,000 are Cadillacs.
		V-8 "39-61"	1,680*	126"	
		V-8 "39-60"	2,090*	127"	
		V-8 "39-75"	2,995*	141"	
		V-16 "39-90"	5,140*	141"	

1940	37,162	V-8 "40-50"	\$1,320*	123"	First to offer custom car interiors at medium price. First to equip passenger cars with Ball Bearing Steering. First to introduce an ultramodern , large, luxurious motor car—the Cadillac Fleetwood 72. During first six months, 1939, Cadillac outsold all makes combined with series having 5 touring sedans priced at or above \$1,300.
		V-8 "40-52"	1,440*	123"	
		V-8 "40-62"	1,745*	129"	
		V-8 "40-60S"	2,090*	127"	
		V-8 "40-72"	2,670*	138"	
		V-8 "40-75"	2,995*	141"	
		V-16 "40-90"	5,140*	141"	
1941	66,130	V-8 "41-61"	1,445*	126"	First to introduce to the medium price field a motor car of unquestioned prestige without a compromise in quality. First high price car to offer Hydra-Matic, the completely automatic transmission that eliminates the clutch pedal and all gear shifting. Cadillac outsold all makes of cars in both the medium and high price groups.
		V-8 "41-62"	1,495*	126"	
		V-8 "41-63"	1,695*	126"	
		V-8 "41-60S"	2,195*	126"	
		V-8 "41-67"	2,595*	139"	
		V-8 "41-75"	2,995*	136"	
1942	16,511	V-8 "42-61"	1,647*	126"	Presentation of the Fortieth Anniversary Cadillacs. Introduction of sealed, ribbed Super-Safe Brakes and All-Weather Ventilation System.
		V-8 "42-62"	1,754*	129"	
		V-8 "42-63"	1,882*	126"	
		(Production halted February, 1942) V-8 "42-60S"	2,435*	133"	
		V-8 "42-67"	2,896*	139"	
		V-8 "42-75"	3,306*	136"	
1943	—	—	—	—	Cadillac-built light tanks and motor carriages contributed immeasurably to the struggle for victory and peace. Precision aircraft engine parts made by Cadillac helped power America's leading combat planes. Army-Navy "E" award to Cadillac for excellence in production of war equipment.
1944	—	—	—	—	Cadillac produced the M-24, one of the world's fastest and most maneuverable combat vehicles of its kind. This famous light tank, which served on all battlefronts, was powered by Cadillac V-type engines and Cadillac Hydra-Matic transmissions.
1945	—	—	—	—	Continued production of the world-famous M-24 light tank for distinguished use in European and Pacific theaters. Introduction of the M-19, a potent anti-aircraft gun motor carriage.

Model Year	Total Production	Type of Cars Produced	List Price (Typical Car)	Wheelbase	Milestones
1946	29,194	V-8 "46-61"	\$2,176*	126"	Presentation of the 1946 Cadillacs, using the battle-proved Cadillac V-type engine and Hydra-Matic transmission, the only automotive units of this kind to be produced and improved without interruption during the war.
		V-8 "46-62"	2,359*	129"	
		V-8 "46-60S"	3,099*	133"	
		V-8 "46-75"	4,298*	136"	
1947	61,926	V-8 "47-61"	2,324*	126"	Postwar production reaches over 90% of prewar peak. Cadillac increases fine-car leadership with over 96,000 unfilled orders.
		V-8 "47-62"	2,523*	129"	
		V-8 "47-60S"	3,195*	133"	
		V-8 "47-75"	4,471*	136"	
1948	52,706 (9 months)	V-8 "48-61"	2,647*	126"	Cadillac presents its greatest engineering achievement in 45 years—the new, compact, better performing, more economical, valve-overhead, V-type, eight-cylinder engine.
		V-8 "48-62"	2,781*	126"	
		V-8 "46-60S"	3,506*	133"	
		V-8 "48-75"	4,471*	136"	
1949	92,554	V-8 "49-61"	2,893*	126"	Cadillac's 1 millionth car produced November 25, 1949.
		V-8 "49-62"	3,050*	126"	
		V-8 "49-60S"	3,828*	133"	
		V-8 "49-75"	4,750*	136"	
1950	103,857	V-8 "50-61"	2,866*	122"	Cadillac production exceeds 100,000 cars for the first time in its history.
		V-8 "50-62"	3,234*	126"	
		V-8 "50-60"	3,797*	130"	
		V-8 "50-75"	4,770*	147"	
1951	110,340	V-8 "51-62"	3,315*	126"	Cadillac moves into defense production of tanks in Cleveland without interruption of automobile production.
		V-8 "51-60"	3,892*	130"	
		V-8 "51-75"	4,887*	147"	
1952	90,715 (11 months)	V-8 "52-62"	3,636*	126"	Cadillac celebrates its Golden Anniversary
		V-8 "52-60"	4,270*	130"	
		V-8 "52-75"	5,361*	147"	

1953	109,657	V-8 "53-62" V-8 "53-60" V-8 "53-75"	\$3,666.26* 4,304.88* 5,604.34*	126" 130" 147"	Cadillac offers highest horsepower engine ever used in an American production motor car.
1954	96,680 (9 months)	V-8 "54-62" V-8 "54-60" V-8 "54-75"	3,932.70* 4,683.32* 5,874.78*	129" 133" 149¾"	Cadillac is First to provide Power Steering as standard equipment on its entire line of cars.
1955	140,778 (11 months)	V-8 "55-62" V-8 "55-60" V-8 "55-75"	3,976.70* 4,728.32* 6,186.78*	129" 133" 149¾"	Cadillac establishes new production and sales records by building and selling over 140,000 motor cars in 11 months.
1956	154,631	V-8 "56-62" V-8 "56-60" V-8 "56-75"	4,291* 5,042* 6,608*	129" 133" 149¾"	Cadillac becomes the only car in its price class ever to be rewarded with an owner demand for over 150,000 cars in one year.
1957	146,840	V-8 "57-62" V-8 "57-60" V-8 "57-75"	4,780.96* 5,614.32* 7,439.88*	129½" 133" 149¾"	Cadillac introduces the fabulous Eldorado Brougham, a limited production luxury motor car with air suspension as standard equipment. All Cadillac models feature the revolutionary new Cadillac tubular-center X frame.
1958	121,786	V-8 "58-62" V-8 "58-60" V-8 "58-75"	4,891* 6,232* 8,460*	129½" 133" 149¾"	Cadillac pioneered Four-Link Rear Suspension adopted as standard equipment with coil springs or (optional at extra cost) air suspension throughout entire line.
1959	142,272	V-8 "59-62" V-8 "59-60" V-8 "59-75"	5,080* 6,233* 9,533*	130" 130" 149¾"	Cadillac becomes the only luxury motor car with an owner demand for well over 1,000,000 cars in a single decade.
1960	142,184	V-8 "60-62" V-8 "60-60" V-8 "60-75"	5,080* 6,233* 9,533*	130" 130" 149¾"	Cadillac introduces to luxury car owners front-fender mounted directional signal indicator lights and an automatically releasing vacuum operated parking brake.
1961	138,379	V-8 "61-62" V-8 "61-60" V-8 "61-75"	5,080* 6,233* 9,533*	129½" 129½" 149¾"	Pre-packed suspension and steering connections minimize maintenance; increase quietness and durability. Over 50% of all 1961 Cadillac motor cars equipped with factory-installed Air Conditioning.

Model Year	Total Production	Type of Cars Produced	List Price (Typical Car)	Wheelbase	Milestones
1962	160,840	V-8 "62-62"	\$5,213*	129½"	Cadillac sets new luxury car records with production of over 160,000 cars with 60% Air Conditioned. Cadillac is First to provide Triple-Safe Brakes and Cornering Lights.
		V-8 "62-60"	6,366*	129½"	
		V-8 "62-75"	9,722*	149¾"	
1963	163,174	V-8 "63-62"	5,214*	129½"	Cadillac First to provide two C-V (constant velocity) joints on propellor shaft for maximum quietness and stability.
		V-8 "63-60"	6,366*	129½"	
		V-8 "63-75"	9,724*	149¾"	
1964	165,959	V-8 "64-62"	5,236*	129½"	Cadillac introduces Comfort Control—First fully automatic year 'round air conditioning-heating system. Cadillac completes multi-million dollar expansion program which includes new Engineering Center, enlarged Manufacturing and Assembly space, multi-level parking facility, complete rebuilding of Administration Building, and conversion of previous Engineering facility to Manufacturing space.
		V-8 "64-60"	6,388*	129½"	
		V-8 "64-75"	9,746*	149¾"	

*Advertised delivered price at Detroit. State and local taxes extra.

1965 alphabetical index

a

Accessory Groups.....	63
Additional Accessories.....	62
Adjustable Steering Wheel.....	52
Air Cleaner.....	99
Air Conditioner-Heater System.....	50, 51
Ash Receivers.....	21
Automatic Choke Control.....	71, 99
Automatic Headlamp Timer.....	54
Automatic Level Control.....	56
Axle Ratios.....	95, 104

b

Backup Lights.....	15
Battery.....	68, 101
Body Construction.....	86-93
Body Insulation.....	93
Body Sealing.....	93
Body Styles.....	24-47
Brake Drums.....	85, 106
Brake Lining.....	85, 106
Brake Pedal.....	22, 85
Brakes.....	85, 106
Brakes, Parking.....	85, 106
Brakes, Power.....	85, 106
Brougham Option.....	18, 44, 45
Bucket Seats.....	32-36, 40, 53
Bumpers.....	12, 13

c

Camshaft.....	98
Carburetor.....	71, 99
Chassis Features.....	76-85
Chassis Over-all View.....	78A
Chauffeur Compartment.....	46A
Choke Control.....	71, 99
Coaxial Resonator.....	68
Comfort Control.....	50
Compression Ratio.....	95, 96
Connecting Rods.....	97
Constant Velocity (CV) Joints.....	74, 75, 104
Controlled Differential.....	58
Convertible Rear Window.....	4
Convertible Top Boot.....	89
Cooling.....	69, 99, 100
Cornering Lights.....	14, 101
Crankcase Vent Valve.....	70
Crankshaft.....	71, 97
Cruise Control.....	57

d

Deck Lid.....	13, 15
Deck Lid Lock, Power.....	59
De-Fogger, Rear Window.....	58
Differential, Controlled.....	58
Dimensions, Exterior.....	27-47, 94
Dimensions, Interior.....	27-47
Directional Signals.....	14
Displacement, Engine.....	95, 96
Distributor.....	101
Doors.....	88
Door Locks.....	91
Door Locks, Power.....	55
Drive Line.....	64, 74

e

Engine Cooling.....	69, 99, 100
Engine Features.....	64-71
Engine Idling.....	67, 71
Engine Lubrication.....	99, 107
Engine Specifications.....	95-101
Engine Warm-Up.....	71
Equipment, Optional.....	24-47, 48-63
Equipment, Standard.....	24-47
Exhaust System.....	68, 98
Exhaust Valves.....	98

f

Fan, Radiator.....	69, 100
Fenders, Front.....	9, 10, 12
Fenders, Rear.....	13, 15
Four-Barrel Carburetor.....	99
Frame.....	78, 103
Front End Design.....	12, 14
Front Suspension.....	80, 103
Fuel System.....	15, 70, 71, 99
Full-Flow Oil Filter.....	70, 99

g

Gas Filler Cap.....	15
General Engine Specifications.....	95-101
General Specifications.....	94, 95
Generator.....	69, 100
Generator Regulator.....	69, 100
Glass.....	4, 88
Glass, Soft Ray.....	51
Glove Compartment.....	21
Grille.....	12
Guide-Matic.....	55

h

Headlamp Control, Power.....	55
Headlights.....	12, 14, 101
Heater-Defroster.....	92
Hood Insulation.....	93
Hood Lock.....	89
Horn.....	101

i

Ignition System.....	101
Instrument Cluster.....	20A
Instrument Panel.....	20A
Intake Valves.....	98
Interior Styling Features.....	19-23
Interiors.....	26A-46A
Insulation, Body.....	93

l

Level Control, Automatic.....	56
License Plate.....	12, 13
Lights and Horn.....	101
Lights, Backup.....	15
Lights, Cornering.....	14, 101
Lights, Directional.....	14
Lights, Headlamp.....	12, 14, 101
Lights, Parking.....	14
Lights, Tail and Stop.....	13, 15
Lock, Deck Lid.....	15
Locks, Door.....	91
Lubricants.....	107
Lubrication.....	99, 107
Luggage Compartment.....	90
Luggage Compartment Lock.....	15, 59

m

Milestones.....	108-116
Mirrors.....	26A-46A

n

New Features.....	4, 5
-------------------	------

o

Oil Change.....	107
Oil Filter, Full-Flow.....	70, 99
Optional Equipment.....	24-47, 48-63

p

Parking Brakes.....	85-106
Parking Lights.....	14
Pistons.....	71, 96
Power Brakes.....	85, 106
Power Deck Lid Lock.....	59
Power Door Locks.....	55
Power Headlamp Control.....	55
Power Seats.....	53
Power Steering.....	82, 105
Power Train.....	64-75
Power Ventipanes.....	59
Power Windows.....	59
Propeller Shaft.....	66A, 67, 74, 104

r

Radiator.....	69, 99
Radiator Fan.....	69, 100
Radios.....	60
Radio Antenna.....	60
Rear Axle.....	67, 75, 104
Rear Axle Ratios.....	95, 104

r

Rear End Styling.....	13, 15
Rear Fender Styling.....	13, 15
Rear Springs.....	81, 103
Rear Suspension.....	81, 103
Rear-view Mirrors.....	26A-46A
Rear Window De-Fogger.....	58
Reflectors, Door Safety.....	26A-46A
Rings.....	96
Rods, Connecting.....	97
Roof Insulation.....	93
Roof Styling.....	16-18

S

Seat Belts.....	61
Seats, Auxiliary.....	46A
Seats, Bucket.....	32-36, 40, 53
Seats, Power Operated.....	53
Shock Absorbers.....	80, 103
Soft Ray Glass.....	51
Spare Tire.....	90
Spare Tire Cover.....	90
Specifications.....	94-107
Springs, Coil.....	80, 81, 103
Standard Equipment.....	24-47
Starting System.....	68, 69, 100, 101
Steering.....	82, 105
Steering, Power.....	82, 105
Steering Wheel.....	22, 52, 83
Steering Wheel, Adjustable.....	52
Styling.....	6-23
Suspension, Front.....	80, 103
Suspension, Rear.....	81, 103

t

Tilt and Telescope Steering Wheel.....	52
Tires and Wheels.....	75, 105
Transmission.....	72, 73, 102
Tread Width.....	83, 95, 105
Trunk Lid Lock, Remote-control.....	59
Turbo Hydra-Matic Transmission.....	72, 73, 102
Twilight Sentinel.....	54

u

Universal Joints.....	74, 75, 104
Upholstery Selections.....	26A-46A

v

Valves.....	98
Ventilation.....	92
Ventipanes, Front, Power.....	59

w

Water Pump.....	99
Wheelbase.....	94
Wheel Bearings, Rear.....	67, 74, 104
Wheel Discs.....	15
Wheels.....	75, 105
Window Regulators, Power.....	59
Windshield Washer-Wiper Coordinator.....	91

The Cadillac Motor Car Division of General Motors Corporation reserves the right to make changes at any time, without notice, in prices, colors, materials, equipment, specifications and models, and also to discontinue models.

All information contained herein has been carefully checked with the most reliable sources, but responsibility for the absolute authenticity of this information cannot be assumed. The right is reserved to change any specifications, parts or equipment at any time without incurring any obligation to equip same on cars built prior to date of such change. *The 1965 Cadillac Data Book was compiled as of August 1964, and was printed in U. S. A. The above reservations apply to all pages unless otherwise noted.*

CADILLAC MOTOR CAR DIVISION
GENERAL MOTORS CORPORATION

OPTIONS AND THE CUSTOMER

To attract more customers, Cadillac provides a wide choice of options suited to individual needs and preferences. For 1965, this constant goal finds expression in a greater than ever variety ranging from eleven body styles, plus a Fleetwood Brougham Option, to a choice of relocating the front seat for added leg room.

Facts concerning both standard and special options are catalogued in three sections separated by captioned dividers. In addition, a general index facilitates finding answers to specific items.

Some important aspects of Cadillac optional specifications include:

Colors. There are 21 options including 5 Eldorado colors which may be ordered on other models at extra charge. Two-tone color combinations are not available. However, a two-tone effect may be obtained by ordering one of four padded vinyl roof color options.

Upholstery. 150 interior options are offered (26 more than last year). Regular production leather is now available in the Sedan de Ville, style L. Four carpet and top of instrument panel colors are optional with white leather.

Accessories. Included among the 21 items of accessories and equipment available for factory installation are two new and exclusive options — an Automatic Level Control and a Tilt and Telescope Steering Wheel. Significant improvements have also been made in the new Cruise Control and the Power Door Locks. These are described in the Accessories section. Opposite the Accessory and Equipment Options chart is a summary of the five group prices as they apply to either regular or Bucket Seats by body style.

Prices. The Manufacturer's Suggested Retail Prices for all options — both standard and special—are included in the original printing of this manual. It, therefore, now contains all necessary information to price and write the specifications of a complete new car order. We believe this innovation resulting from readers' suggestions will be received with approval.

Fleetwood Seventy-Five. All general statements apply only to 129.5" and 133" wheelbase cars, unless specifically stated that the information does include Fleetwood Seventy-Five Sedan and Limousine. Pages 62 through 71 are devoted exclusively to the standard and optional specifications of the Fleetwood Seventy-Five, including illustrations of the Landau Roof Option.

Cadillac

1965 BODY STYLES

SERIES	STYLE NO.	CODE	NAME	WHEELBASE	OVERALL LENGTH
--------	-----------	------	------	-----------	----------------

<i>Calais</i>	68257	G	Calais Coupe	129.5"	224"
	68239	N	Calais Hardtop Sedan	129.5"	224"
	68269	K	Calais Sedan	129.5"	224"

<i>De Ville</i>	68367	F	De Ville Convertible	129.5"	224"
	68357	J	Coupe de Ville	129.5"	224"
	68339	B	Hardtop Sedan de Ville	129.5"	224"
	68369	L	Sedan de Ville	129.5"	224"

<i>Fleetwood</i>	68467	E	Fleetwood Eldorado Convertible	129.5"	224"
	68069	M	Fleetwood Sixty Special Sedan	133"	227.5"
	68069B		<i>Brougham</i> OPTION		
	69723	R	Fleetwood Seventy-Five Sedan	149.8"	243.8"
	69733	S	Fleetwood Seventy-Five Limousine	149.8"	243.8"
	69890	Z	Commercial Chassis	156"	249.5"

CODE AND ACRYLIC NUMBERS FOR 1965 COLORS

Code	Name	MANUFACTURERS IDENTIFICATION			% Used in 1964
		Rinshed-Mason	Du Pont	Forbes	
10	Sable Black	L 55 K 011	868-96459	710-360	10.6
12	Aspen White	L 55 W 001	868-96298	710-300	22.1
16	Starlight Silver	L 58 A 003	867-97210	720-399	5.5
18	Ascot Gray	L 58 A 020	867-97302	720-400	1.9
20	Hampton Blue	L 58 B 036	867-97303	720-401	9.0
24	Tahoe Blue	L 58 B 037	867-97304	720-402	4.3
26	Ensign Blue	L 58 B 038	867-97305	720-403	2.5
28	Alpine Turquoise	L 58 B 015	867-97308	720-404	6.8
30	Cascade Green	L 58 G 024	867-97306	720-405	5.2
36	Inverness Green	L 58 G 025	867-97307	720-406	1.9
40	Cape Ivory	L 55 Y 009	868-97309	710-407	
42	Sandalwood	L 55 N 010	868-97310	710-408	6.1
44	Sierra Gold	L 58 N 019	867-97038	720-377	8.7
46	Samoan Bronze	L 58 R 014	867-97312	720-409	
48	Matador Red	L 58 R 001	867-96263	720-349	2.2
49	Claret Maroon	L 58 M 010	867-97311	720-410	2.1

ELDORADO FIREMIST COLORS

90	Peacock Firemist	L 58 B 039	867-97314	720-411	22.0
92	Sheffield Firemist	L 58 A 013	867-97313	720-412	18.0
96	Jade Firemist	L 58 B 040	867-97315	720-413	10.6
97	Saddle Firemist	L 58 N 014	867-97083	720-418	32.2
98	Crimson Firemist	L 58 R 008	867-97085	720-415	17.2

The percentages in the column at the right represent the popularity of comparable colors used during the previous model. Because Cape Ivory is unlike last year's Lime and Samoan Bronze is not similar to Palomino, percentages are not listed for these two new colors and the column will, therefore, not total 100%.

1965 CADILLAC EXTERIOR RECOMMENDATIONS

CODE NO.	COLORS	PADDED ROOF J-B-L	<i>Brougham</i> OPTION M	CONVERTIBLE TOP F-E
10	Sable Black	62 61	62	2, 1
12	Aspen White	62 61	62 61	1, 2
16	Starlight Silver	62	62	2, 1
18	Ascot Gray	62	62	2, 1
20	Hampton Blue	62 61 63	63 62 61	1, 3, 2
24	Tahoe Blue	62 61 63	62 61 63	1, 3, 2
26	Ensign Blue	62 61 63	62 61	1, 3, 2
28	Alpine Turquoise	61 62	61 62	1, 2, 6
30	Cascade Green	62 61 66	62 61 66	1, 4, 2, 6
36	Inverness Green	62 66 61	62 66	6, 4, 1, 2
40	Cape Ivory	62	62	2
42	Sandalwood	66 62 61	66 62	6, 1, 2
44	Sierra Gold	62 66 61	66 62 61	6, 2, 1
46	Samoan Bronze	61 62 66	61 62 66	1, 2, 6
48	Matador Red	62 61	62 61	1, 2
49	Claret Maroon	62 66 61	62 66 61	1, 2, 6

ELDORADO FIREMIST COLORS

Available on other models at extra charge

90	Peacock Firemist	62 61	62 61	1, 5, 2
92	Sheffield Firemist	62	62	2, 1
96	Jade Firemist	61 62 66	62 61 66	1, 6, 2
97	Saddle Firemist	62 66 61	62 66 61	6, 1, 2
98	Crimson Firemist	61 62	61 62	1, 2

PADDED ROOFS

61	White
62	Black
63	Blue
66	Sandalwood

CONVERTIBLE TOPS

DE VILLE		ELDORADO	
1	White	1	White
2	Black	2	Black
3	Blue	5	Gray-Blue
4	Green	6	Sandalwood
6	Sandalwood		

Two-tone paint color combinations not available.

PADDED ROOFS

BODY STYLES		EXTRA CHARGE	COLORS	
Coupe de Ville	J	\$ 123.65	61	White
Hardtop Sedan de Ville	B	\$ 139.75	62	Black
Sedan de Ville	L	\$ 139.75	63	Blue
Fleetwood Seventy-Five with Landau Roof	R or S	\$ 537.50 \$1,935.00	66	Sandalwood

<p style="text-align: center;">HOW TO ORDER</p> <p>Combine the padded roof color code number with the lower car color code. i.e., 4962, 2061, etc.</p>	<p style="text-align: center;">TWO-TONE COMBINATIONS</p> <p>Except on Fleetwood Seventy-Five models, two-tone paint combinations are not available due to the new body design. A two-tone effect may be obtained by ordering a padded roof combination.</p>
<p style="text-align: center;">FELT PADDED</p> <p>A cross-grained vinyl fabric is tailored to the roof over an insulation of felt padding. It is not applied directly to the metal.</p>	<p style="text-align: center;">COLOR CODES—CAUTION</p> <p>The code numbers' second digit corresponds to the Convertible top color codes. Two of the padded roof codes, therefore, differ from last year (Black and Sandalwood).</p>

EXAMPLE

SAABA USA 403M 8-44		CADILLAC MOTOR CAR DIVISION GENERAL MOTORS CORP. BOX 307 DETROIT, MICH. 48266 1965 CAR ORDER		DATE	ALLOT. MONTH	OUTLET NO.	ORDER NO.										
CHARGE TO AUTHORIZED CADILLAC OUTLET AT:				STATE													
CITY				SHIP TO (LEAVE BLANK, IF SAME)		AT	OUTLET NO.										
AUTHORIZED SIGNATURE				PURCHASER		PURCHASER (REPEAT)											
SIGNATURE				CUSTOMER WILL CALL		DATE											
SPECIAL TRIM ONLY	TRIM	S R NO.															
	INSERTS	BOLSTERS															
	SIDE AIR SEATS	HEAD LIVING															
	CARPETS	TOP TRAY PANEL															
	STYLE NO.	SPINNING WHEEL															
68369							OUTLET NO.										
COLOR	TOP	TRIM	1-2	3-9	F A	X R	R-1-2	E Y	T D	K U	Q M	J S	G C	N F	1-7	L V	ORDER NO.
1262																	L

COLORS

Exclusive Shades. 19 of Cadillac's 21 options are exclusive and not shared with other G.M. cars. Of the 15 new colors for 1965, Cape Ivory and Samoan Bronze are in entirely new color families.

Two-Tone Not Available. The new body design of the 1965 cars does not permit a separation of color between the upper structure and lower panels. However, a two-tone effect may be obtained by ordering a padded roof option in a contrasting color. NOTE: Two-tone colors may still be ordered on the Fleetwood Seventy-Five at no extra charge.

Eldorado Colors. Five Firemist colors are offered on the Fleetwood Eldorado Convertible. In addition to these, any of the 16 standard line colors may be ordered.

On other styles, the five Eldorado colors are available at extra charge. See specimen for ordering on next page.

EXTRA CHARGE \$134.40

Special Colors. Any desired past model or special shade can be supplied on a special order basis.

EXTRA CHARGE \$134.40

Above price does not include extra-high luster colors such as Firemist, "Fire-Frost", etc. Prices for these furnished upon request. High metallic is not possible on opaque colors such as white, yellow or light beige.

How To Order. Type 0 in the color space and complete name and lacquer number in center section of the order form. See specimens on the following pages.

Time. Allow 5 to 6 weeks for shipment. The procurement of special colors requires extra time for mixing by a qualified chemist, who must take time out from regular duties, to formulate the single special color order. This explanation is offered to provide a better understanding of the time and cost factors involved in handling one-of-a-kind individual orders.

Harmonious Interior. Whenever a special color is contemplated, careful consideration should be given to the availability of a harmonious upholstery.

Facilities. High up on a newly added fifth floor, sheet metal for Cadillac cars is painted in the industry's finest facilities. Quality control is maintained by an atmosphere in which filtered air is hospital clean to eliminate any dust particles that could be absorbed into painted surfaces.

Greater durability and corrosion resistance is achieved from advanced methods and equipment: dipping the primer coat assures complete and uniform coverage; infra-red heated ovens bake the prepared surface with controlled precision; a continuous waterfall on both sides of down-draft spray booths creates extra cleanliness; regulated humidity prevents defects that could result from uncontrolled moisture.

Primer dipping, automatic spraying of sealer, overall hand-spraying of surfacer, wet sanding by hand and three color coats all contribute to produce Cadillac's incomparable finishes.

EXTERIOR COLOR CODES TRANSITION

Of necessity, ten 1965 color code numbers similar in tone to their previous counterparts have been changed. Attention is called to these revised numbers to prevent misunderstanding.

1965	1964
10 Sable Black	
12 Aspen White	
16 Starlight Silver	14 Nevada Silver
18 Ascot Gray	16 Cardiff Gray
20 Hampton Blue	22 Beacon Blue
24 Tahoe Blue	
26 Ensign Blue	
28 Alpine Turquoise	29 Turino Turquoise
30 Cascade Green	32 Seacrest Green
36 Inverness Green	
40 Cape Ivory	
42 Sandalwood	44 Bahama Sand
44 Sierra Gold	46 Sierra Gold
46 Samoan Bronze	
48 Matador Red	50 Matador Red
49 Claret Maroon	52 Royal Maroon

ELDORADO FIREMIST COLORS

90 Peacock Firemist	92 Firemist Blue
92 Sheffield Firemist	
96 Jade Firemist	
97 Saddle Firemist	
98 Crimson Firemist	

Two-tone paint color combinations not available.

UPHOLSTERY

New Upholstery Options. Leather options have been added to the Sedan de Ville (style L) plus additional carpet and top of instrument panel colors with white leather. This provides a choice of 150 upholstery options in 11 models and 8 trim styles.

Four Carpet Colors Optional with White Leather. For better interior-exterior harmony when white leather is ordered, a choice of four carpet colors is offered on the de Ville Series and Fleetwood Sixty Special. The designated carpet color—Black, Medium Blue, Red or Turquoise—includes the color of the top of instrument panel and rear shelf.

Belt Line Color. On all interior combinations except white, the top of instrument panel color extends along the top of the doors, rear quarters and shelf, forming a dark tone belt line from windshield to rear window.

With white leather upholstery the upper part of the doors and rear quarters remain white. Only the top of instrument panel, "eyebrow" pad at forward part of front door and rear shelf are in dark tone.

Order Interior From Chart on Page 17. Interior colors are selected and toned to harmonize with their counterpart exterior colors. Therefore, the first upholstery recommendation on color-trim chart is designed to result in a co-ordinated interior and exterior.

The upholstery selection involves the complete interior decor of the car and if not harmonized with the exterior color, becomes uncomplimentary to the automobile.

Selections opposing the experienced judgment of trained specialists in color harmony could result in disappointment even to the customer making them. The combination may be regarded as poor taste by

others, although it was the original purchaser's choice.

A firm stand should be exercised to channel the upholstery selection according to the recommended options; otherwise, the finished product may present an appearance contrary to the customer's expectations.

Why No Cloth Trim Recommendations For Eldorado Colors? The Peacock and Jade Firemist colors were developed exclusively for the Eldorado. Consequently, only Gray-Blue (code 461) and Blue-Green (code 476) Eldorado leathers are color-keyed to these exterior shades.

Good Taste. Taste, which is a developed skill, is frequently confused with untrained personal preference. Most customers respect and adhere to Cadillac color-upholstery recommendations, as they are based upon standards of esthetic principles and experience. They are part of Cadillac's quality standards.

Combination Not on Chart. If the color upholstery selection is not listed on chart (page 17) please mention on the order that it is definitely wanted. Otherwise, it may be construed as a typographical error. An adherence to this suggestion will avoid delays in ascertaining accuracy of order. Failure to verify the specifications may result in the production of a discordant color scheme.

Three-Digit Code Numbers. New three-digit upholstery identification code numbers have been adopted. For a better understanding of upholstery codes see explanation on page 18.

Special Upholstery. Whenever a special interior is actually wanted, be sure to type 000 in TRIM space and detail the desired specifications according to suggestions in **Special Interiors** section of this book.

1965 CADILLAC UPHOLSTERY OPTIONS

CONVERTIBLES				
DE VILLE Style F		LEATHER	ELDORADO Style E	
351	Black	451	Black	
352	White—Black Carpet	452	White—Black Carpet	
353	White—Blue Carpet			
354	White—Red Carpet	454	White—Red Carpet	
355	White—Turquoise Car.			
360	Blue	461	Gray-Blue	
370	Green	476	Blue-Green	
381	Sandalwood	481	Sandalwood	
383	Tan	483	Tan	
386	Bronze			
388	Red	488	Red	
Bucket Seats: To order add B to code. e.g., 351B, 352B, 451B, 452B, etc.				
Tops - F		Tops - E		
1	White	1	White	
2	Black	2	Black	
3	Blue	5	Gray-Blue	
4	Green			
6	Sandalwood	6	Sandalwood	

CALAIS SERIES—Styles G—N—K			
INSERTS CLOTH			BOLSTERS COATED FABRIC
210	Black	Delhi	White
216	Gray	Delhi	Gray
220	Blue	Delmar	Blue
226	Midnight Blue	Delhi	Midnight Blue
228	Turquoise	Delmar	Turquoise
230	Green	Delmar	Green
241	Sandalwood	Delhi	Sandalwood

DE VILLE SERIES—Styles J—B—L			
INSERTS CLOTH			BOLSTERS LEATHER
310	Black	Drummond	White
319	Dk. Gray	Delta	Gray
320	Blue	Drummond	Blue
326	Midnight Blue	Delta	Midnight Blue
328	Turquoise	Delta	Turquoise
330	Green	Drummond	Green
341	Sandalwood	Delta	Sandalwood
346	Bronze	Drummond	Bronze

White leather combinations have top of instrument panel and rear shelf in color to match carpets.

OPTIONAL LEATHER—EXTRA CHARGE Styles J—B—L		
351	Black	Bucket Seats: Available on de Ville styles J and B. To order add B to code. e.g., 351B, 352B, etc.
352	White—Black Carpet	
353	White—Blue Carpet	
354	White—Red Carpet	
355	White—Turquoise Carpet	
381	Sandalwood	
388	Red	

FLEETWOOD SERIES—Style M			
INSERTS CLOTH		BOLSTERS LEATHER	
011	Black	Devon	Black
016	Gray	Devon	Gray
020	Blue	Devon	Blue
028	Turquoise	Devon	Turquoise
041	Sandalwood	Devon	Sandalwood

ALL DANFORTH CLOTH Embroidered Back Rest Panels			
018	Gray	030	Green
021	Blue	044	Beige
026	Midnight Blue		

OPTIONAL LEATHER—EXTRA CHARGE			
051	Black		
052	White—Black Carpet		
053	White—Blue Carpet		
054	White—Red Carpet		
055	White—Turquoise Carpet		
081	Sandalwood		
088	Red		

CROSS-GRAINED VINYL PADDED ROOFS Styles J—B—L—R—S AND <i>Optional</i> OPTION Style M			
61	White	63	Blue
62	Black	66	Sandalwood

FLEETWOOD SERIES—Styles R—S			
INSERTS & BOLSTERS Danforth Cloth Has Embroidered Design			
716	Gray	Decordo Cloth	
718	Gray	Danforth Cloth	
719	Med. Gray	Decordo Cloth	
726	Midnight Blue	Danforth Cloth	
744	Beige	Danforth Cloth	

On Limousine style S, front compartment will be standard Black leather. Gray, Beige or Midnight Blue leather is optional and may be ordered by adding code G for Gray, F for Beige or M for Midnight Blue. e.g., 716G, 718G, 719G would have Gray leather front. 744F would have Beige leather front and 726M would have Midnight Blue leather front.

Optional Leather Upholstery

Leather In Sedan De Ville, Style L. Seven combinations of optional leather are now offered in **all three** de Ville closed body styles and the Fleetwood Sixty Special. Specify in the same manner as any standard upholstery. Orders will be scheduled for production in the regular way.

Trim Style. In de Ville models the same single button, exposed stitch Y-seam trim style is used with either leather or cloth upholstery. The Sixty Special, however, has three separate styles according to type of material. Leather is trimmed with 1½" pleats; embroidered Danforth cloth is plain and Devon cloth has 3" pleats.

Bucket Seats. With leather upholstery, Bucket Seats are an extra charge production option on three de Ville styles:

Convertible	F
Coupe	J
Hardtop Sedan	B

On the Eldorado Convertible they are a no charge option.

Order by adding code B to upholstery numbers. On the Sedan de Ville (style L) and Sixty Special (style M) Bucket Seats are not a regular production option. However, they are available on a special order basis as explained on pages 20 through 22.

In closed de Ville styles and Sixty Special, cloth upholstered Bucket Seats are available on a special order.

Coupe Type Front Seat. In the leather upholstered de Ville four-door Sedans (styles B and L) the front seat will be the Coupe type with individual back rests. This creates an appearance of separate seats, especially when the center arm rest is lowered.

Leather upholstered Sixty Special will

have undivided Sedan type back rest which includes assist grips on the back side of the front seat. Coupe type seat is not available in this model.

Assist Grips. Coupe type seats do not have assist grips on the back side of the back rest, as do four-door Sedan type front seats. If assist handles are wanted with leather trim, they can be furnished on a special order basis by specifying "Sedan Type Front Seat".

Non-Perforated Leather. On a special order, non-perforated leather without the Aztec grain may be ordered. Add \$21.45 to prices on page 15 for total non-perforated optional leather charge. See page 78 for order sample.

Special Leather Colors. Any de Ville series or Eldorado leather color, in single or two-tone combination, Aztec or non-perforated grain is available on special order. See pages 73 and 79 for a list of colors and prices.

Why Leather Not In Calais Series? There are limitations to the overall number of interior options that may be scheduled on a production basis. Therefore, to include leather in the Calais series would require a reduction of some other trims. As the demand for leather in the Calais series is less than in other models, the available manufacturing capacity is utilized for such other models.

Leather in the Calais series is available on a special order basis with a choice of 16 options. See price list on page 73.

000 In Trim Space. On special leather orders mark 000 in TRIM space on order form. Do not use the upholstery code number in the regular TRIM space as this may result in the order being overlooked, causing unnecessary delay. See SPECIAL INTERIORS section for non-standard interior ordering instructions.

Optional Leather Upholstery

DE VILLE	FLEETWOOD		
Coupe J	Sixty Special M	Leather	Carpets & Top of Instrument Panel
Hardtop Sedan B			
Sedan L			

CODES		COLORS	
351	051	Black	Black
352	052	White	Black
353	053	White	Med. Blue
354	054	White	Dk. Red
355	055	White	Dk. Turquoise
381	081	Sandalwood	Med. Sandalwood
388	088	Red	Dk. Red

M. S. R. PRICES	DE VILLE		SIXTY SPECIAL
	J-B	L	M
Optional Leather	\$ 140.90	\$ 140.90	\$ 140.90
Bucket Seats	\$ 187.85		
Total	\$ 328.75		

Seven leather combinations are available on four body styles at extra charge.

1965 TRIM-COLOR RECOMMENDATIONS

CLOTH COLOR	HARMONIOUS EXTERIOR COLORS
Black	10 12 16 18 40 48 49 (46 for Calais and Fleetwood only)
Gray	10 16 18
Blue	12 20 24 26
Midnight Blue	12 16 18 20 24 26
Turquoise	12 28
Green	30 36
Sandalwood	40 42 44 48 49 (46 for Calais and Fleetwood only)
Beige	42 44 49
Bronze	46

LEATHER COLOR	HARMONIOUS EXTERIOR COLORS
Black	ALL
White— Black Carpet	10 12 30 36 40 46 49 90 96 98 (18—DeVilles only) (48—Style F only)
White— Blue Carpet	20 24 26
White— Red Carpet	48 98
White— Turquoise Carpet	28
Sandalwood	28 30 36 42 44 46 49 96 97
Red	10 12 16 18 26 48 92 98
Blue	12 20 24 26
Green	30 36
Bronze	46
Tan	36 40 42 44 96 97
Gray Blue	12 90
Blue Green	96



1965 COLOR-TRIM RECOMMENDATIONS

COLOR	Calais Coupe and Sedans	De Ville Coupe and Sedans	Fleetwood Sixty Special Sedan	OPTIONAL LEATHER	
				De Ville and Sixty Special	De Ville Convertible
	G-N-K	J-B-L	M	J-B-L-M	F
10	210 216	310 319	011 016 or 018	351 388 352 051 088 052	351 388 352
12	210 220 228 226	310 320 328 326	011 020 or 021 028 026	388 351 352 051 088 052	388 351 352 360
16	216 210 226	319 310 326	016 or 018 011 026	351 388 051 088	351 388
18	216 210 226	319 310 326	016 or 018 011 026	388 351 352 051 088	388 351 352
20	220 226	320 326	020 or 021 026	353 351 053 051	360 353
24	226 220	326 320	026 020 or 021	353 351 053 051	360 353
26	226 220	326 320	026 020 or 021	353 388 351 053 088 051	360 353 388
28	228	328	028	355 351 381 055 051 081	355 351 381
30	230	330	030	381 351 352 081 051 052	370 351 381 352
36	230	330	030	381 351 352 081 051 052	370 381 383 351 352
40	210 241	310 341	011 041	351 352 051 052	351 352 383
42	241	341	041 044	381 351 081 051	381 383
44	241	341	044 041	381 351 081 051	381 383 351
46	210 241	346	011 041	352 381 351 052 081 051	386 352 381
48	210 241	310 341	011 041	354 351 388 054 051 088	388 354 351 352
49	241 210	341 310	041 044 011	351 381 352 051 081 052	351 352 381

FLEETWOOD ELDORADO CONVERTIBLE - STYLE E

90	461 452	COLOR	
92	451 488		
96	476 452 451 481 483	10	451 488 452
97	483 481 451	12	488 451 452 461
98	488 454 451 452		

NEW THREE DIGIT UPHOLSTERY CODE NUMBERS

To accommodate new electronic data processing systems, the upholstery code numbers have been increased to three digits.

<p>1 CAR SERIES NUMBERS</p> <p>The first digit, prefixing two color digits, represents the series as follows:</p> <table border="1"> <thead> <tr> <th>Series Number</th> <th>Car Series</th> <th>Body Styles</th> </tr> </thead> <tbody> <tr> <td>2</td> <td>Calais</td> <td>G N K</td> </tr> <tr> <td>3</td> <td>De Ville</td> <td>F J B L</td> </tr> <tr> <td>4</td> <td>Eldorado</td> <td>E</td> </tr> <tr> <td>0</td> <td>Fleetwood 60</td> <td>M</td> </tr> <tr> <td>7</td> <td>Fleetwood 75</td> <td>R S</td> </tr> </tbody> </table>			Series Number	Car Series	Body Styles	2	Calais	G N K	3	De Ville	F J B L	4	Eldorado	E	0	Fleetwood 60	M	7	Fleetwood 75	R S	<p>2 COLOR GROUPS</p> <p>A coding pattern has been devised to create uniformity between the exterior and interior codes, according to color family. A series of numbers is reserved for color groups as follows:</p> <table border="1"> <thead> <tr> <th>Code Numbers</th> <th>Seat Insert Colors</th> </tr> </thead> <tbody> <tr> <td>10 to 15</td> <td>Black, White</td> </tr> <tr> <td>16 to 19</td> <td>Gray</td> </tr> <tr> <td>20 to 29</td> <td>Blue, Turquoise</td> </tr> <tr> <td>30 to 39</td> <td>Green</td> </tr> <tr> <td>40 to 49</td> <td>Beige, Red & Warm Colors</td> </tr> </tbody> </table>			Code Numbers	Seat Insert Colors	10 to 15	Black, White	16 to 19	Gray	20 to 29	Blue, Turquoise	30 to 39	Green	40 to 49	Beige, Red & Warm Colors
Series Number	Car Series	Body Styles																																	
2	Calais	G N K																																	
3	De Ville	F J B L																																	
4	Eldorado	E																																	
0	Fleetwood 60	M																																	
7	Fleetwood 75	R S																																	
Code Numbers	Seat Insert Colors																																		
10 to 15	Black, White																																		
16 to 19	Gray																																		
20 to 29	Blue, Turquoise																																		
30 to 39	Green																																		
40 to 49	Beige, Red & Warm Colors																																		
<p>3 EXAMPLE</p> <p>Number 30 represents a green interior. It is preceded by 2 for the Calais Series (230), 3 for de Ville (330), etc.</p> <p>The lowest number in the group represents the lightest tone. Each higher number is progressively darker.</p> <p>320 is Lt. Blue 326 is Midnight Blue</p> <p>716 is Lt. Gray 719 is Medium Gray</p>			<p>4 LEATHER CODES</p> <p>To provide identification for leather options, a factor of 40 is added to the last two numbers resulting in codes starting with 51.</p> <p>EXAMPLE</p> <p>320 is a Blue cloth combination</p> <p>+40</p> <p>360 is a Blue leather combination</p>																																

To comprehend the new 3 digit numbers more easily, visually disregard the first number as it will automatically be correct according to car series. In so doing, a quicker familiarity with the new upholstery symbols and their closer relationship to the exterior color codes will become apparent.

INTERIOR	EXTERIOR
310 is black	10 is Sable Black
016 is gray	16 is Starlight Silver
220 is blue	20 is Hampton Blue

Interior Features

Carpets in Harmonizing Colors. White leather interiors in de Ville and Fleetwood Sixty Special models have four carpet and top of instrument panel color options for better harmony with the exterior color selection.

Embroidered Trim Styles. The Fleetwood Sixty Special and Seventy-Five models have an interior option of a finely woven Danforth cloth with embroidered medallion patterns on both front and rear back rests. This cloth also has a swiss dot effect, which adds a pleasing softness to its appearance.

Tamo Wood Paneling. Fleetwood Eldorado Convertible and Sixty Special sedan have paneling of imported Japanese Tamo Wood. Although this rare ash wood has unusual patterns, only the most distinctive grain is selected for Cadillac cars.

Bucket Seat Consoles. New padded top lid and facing.

Rotary Seat Adjuster Switch. Instead of the three-button arm rest type, all 6-way front seat adjusters have a rotary type switch located on the left side of the seat panel.

Free Folding Center Arm Rests. All Coupes, including the Calais style G, have front center arm rests. They fold free which means the section above the arm rest and between the two back rests is open, simulating individual appearing seats especially with arm rest lowered.

Instrument Panel. The components of the newly designed two-section lower instrument panel blend with counterpart designs on the front doors, forming a single unit type front compartment.

Back Rests. All back rests are new "higher" type.

Convertible Features

Top Boot Fastener. A new hook and loop nylon ribbon fastener secures the top boot to the upper part of the rear seat back rest. The fastening is accomplished by gently pressing together two surfaces: one covered with microscopic burr-like hooks, the other with a pile of equally tiny loops. These two parallel ribbons cling when the hooks engage the loops. In addition, there is a concealed single stud and button fastener at each end. This unique closure attaches the boot to the seat with tailored smoothness, uninterrupted by any visible fasteners. Peeling easily separates the boot from the back rest.

Top Boot. Material is two-way stretch coated fabric.

Rear Window in convertibles is glass.

Accessories and Equipment

Simplified Ordering. The accessory and equipment groups have been so devised that to order a fully equipped car only two group numbers, plus the symbols for license frames and rear seat belts, need be marked on the new car order. Example: 2 5 9 A.

Basic Groups. Depending upon the type of radio and if Comfort Control is wanted, select basic group 1, 2, 3 or 4. The optional radios and Comfort Control are marked on the chart to indicate variance in the groups.

Group 5. Add group 5 to order all available options. If complete group is not wanted, order desired items individually.

Groups For All Models. Although some items are standard equipment and others not available on certain models, all groups may be used on any body style except Fleetwood Seventy-Five. Group prices will, of course, vary depending upon body style and type of seats ordered.

New Items. Significant changes on some options, an exclusive Tilt and Telescope Steering Wheel and a new Automatic

Level Control are described on pages 26 and 27.

Local Installation. The accessories and equipment listed on page 25 are all available for factory installation on new cars. Other packaged accessories which are not installed in production are available through the Cadillac Parts Warehouses. These are for local dealer installation and include such equipment as: Radio Foot Selector Control, Rear Window Defogger, Floor Mats, Cushion Toppers and others. See page 36 for price list.

Sell Groups. A survey on the subject reveals the majority of retail outlets favor the continued use of groups for ordering accessories. They help sell more fully equipped cars and simplify new car ordering and pricing. Most dealers find less resistance if the additional convenience features are sold as a package instead of itemizing each part. Those who do not use this method should consider changing. Sell more options by selling whole groups.

This is mentioned as a matter of information, as groups are no longer used in factory production. They are "exploded" and each part is specified individually.

GROUP PRICES

STYLES	GROUPS				
	1	2	3	4	5

WITH 6-WAY FRONT SEAT ADJUSTER

G Calais Coupe	\$1003.80	\$1030.60	\$ 509.30	\$ 536.10	\$ 574.60
N Calais Hardtop Sedan	\$1007.05	\$1033.85	\$ 512.55	\$ 539.35	\$ 598.85
K Calais Sedan					
F De Ville Convertible	\$ 857.35	\$ 884.15	\$ 362.85	\$ 389.65	\$ 574.60
J Coupe de Ville					
B Hardtop Sedan de Ville	\$ 860.60	\$ 887.40	\$ 366.10	\$ 392.90	\$ 598.85
L Sedan de Ville					
E Eldorado Convertible	\$ 714.85	\$ 741.65	\$ 220.35	\$ 247.15	\$ 420.75
M Sixty Special Sedan	\$ 860.60	\$ 887.40	\$ 366.10	\$ 392.90	\$ 445.00

WITH 4-WAY DRIVER'S BUCKET SEAT ADJUSTER

F De Ville Convertible	\$ 825.95	\$ 852.75	\$ 331.45	\$ 358.25	\$ 574.60
J Coupe de Ville					
B Hardtop Sedan de Ville	\$ 829.20	\$ 856.00	\$ 334.70	\$ 361.50	\$ 598.85
E Eldorado Convertible	\$ 714.85	\$ 741.65	\$ 220.35	\$ 247.15	\$ 420.75

1965 CADILLAC ACCESSORY & EQUIPMENT OPTIONS

FACTORY INSTALLED GROUPS AND CODES

<p style="text-align: center; font-size: 24pt; font-weight: bold;">1</p> <p>X WINDOWS, POWER W TIRES, WHITE WALL R RADIO, AM E GLASS, SOFT RAY Y } SEAT ADJUSTER, 6-way front or } T } SEAT ADJUSTER, 4-way driver's bucket D DOOR EDGE GUARDS K COMFORT CONTROL (air conditioner)</p>	<p style="text-align: center; font-size: 24pt; font-weight: bold;">2</p> <p>X WINDOWS, POWER W TIRES, WHITE WALL R1 RADIO, AM-FM E GLASS, SOFT RAY Y } SEAT ADJUSTER, 6-way front or } T } SEAT ADJUSTER, 4-way driver's bucket D DOOR EDGE GUARDS K COMFORT CONTROL (air conditioner)</p>
<p style="text-align: center; font-size: 24pt; font-weight: bold;">3</p> <p>X WINDOWS, POWER W TIRES, WHITE WALL R RADIO, AM E GLASS, SOFT RAY Y } SEAT ADJUSTER, 6-way front or } T } SEAT ADJUSTER, 4-way driver's bucket D DOOR EDGE GUARDS</p>	<p style="text-align: center; font-size: 24pt; font-weight: bold;">4</p> <p>X WINDOWS, POWER W TIRES, WHITE WALL R1 RADIO, AM-FM E GLASS, SOFT RAY Y } SEAT ADJUSTER, 6-way front or } T } SEAT ADJUSTER, 4-way driver's bucket D DOOR EDGE GUARDS</p>

<p style="text-align: center; font-size: 24pt; font-weight: bold;">5</p> <p>U HEADLAMP CONTROL, GUIDE-MATIC Q STEERING WHEEL, TILT & TELESCOPE M DOOR LOCKS, POWER J TWILIGHT SENTINEL S TRUNK LOCK, remote control G CONTROLLED DIFFERENTIAL C CRUISE CONTROL N VENT WINDOWS, POWER P LEVEL CONTROL, automatic</p>	<p style="text-align: center; font-weight: bold;">OTHER CODES</p> <p>8 LICENSE FRAME, ONE or 9 LICENSE FRAMES, TWO F FILLER PLATE A SEAT BELTS, 2 REAR R2 RADIO, REAR CONTROL (AM) — Fleetwood 75 Only</p> <p style="font-weight: bold;">OPTIONAL GEAR RATIO</p> <p>1 3.21 7 3.77 — Fleetwood 75 Only O SEAT BELTS, 2 FRONT DELETION OPTION H HEATER-DEFROSTER DELETION OPTION</p>
---	---

Standard equipment on all cars includes two front seat belts and heater-defroster. However, a deletion option is available at reduced cost. The heater-defroster is an integral component of Comfort Control and cannot be deleted when this feature is ordered. Tilt and Telescope Steering Wheel, Remote Control Trunk Lock, Automatic Level Control and Comfort Control are not available on Fleetwood Seventy-Five models. To order air conditioner, use same symbol K.

CADILLAC COMFORT CONTROL

INCLUDED IN GROUPS 1 AND 2

Cadillac Comfort Control is a combination air conditioning and heating system that functions automatically. A single dial setting maintains the selected interior temperature year 'round. This feature is included in Basic Groups 1 and 2 or may be ordered separately as code K.

AIR CONDITIONER

FOR FLEETWOOD SEVENTY-FIVE

A front compartment manual control type of air conditioner-heater system is available for the Fleetwood Seventy-Five Limousine and Sedan. In addition, a separate cooling system is provided for the rear compartment. An evaporator in the trunk discharges cooled air through two adjustable overhead outlets. Control for the rear blower is located behind a sliding panel above the right rear side arm rest. There is also a temperature control and a switch that turns the air conditioner compressor on or off, providing independent heating and air conditioning in the rear. Air conditioner cannot be furnished without the heater. Use code K to order. Do not order groups.

SOFT RAY GLASS, 9.00—15 TIRES, LIGHT COLORS RECOMMENDED

The lighter exterior colors, because of their heat reflecting characteristics, contribute to lowering the interior temperature as does Soft Ray Glass. Both are recommended for cars equipped with Comfort Control or Air Conditioning. Also, on Comfort Control equipped cars white sidewall tires are suggested due to their larger 9.00—15 size.

GEAR RATIOS

3.21—1 axle gear ratio is standard without option on Comfort Control equipped cars.

3.36—1 is the standard ratio for Fleetwood Seventy-Five cars with or without air conditioning. 3.77—1 is optional.

GLASS

STANDARD

Clear Glass

OPTIONAL

Soft Ray—Code E

Solid Tempered Safety Plate—Standard

The side, vent and rear windows have curved solid tempered safety plate glass. The rear window in Convertible models is made of curved solid tempered safety plate untinted glass. The surface hardness of glass makes it more scratch-resistant than the previously used Convertible backlight materials, thereby retaining its clear appearance.

Laminated Safety Plate—Standard

Windshields in all cars and the division glass in the Fleetwood Seventy-Five Limousine are laminated safety plate glass.

Soft Ray Glass—Optional

All optional Soft Ray Glass is tinted and is used in all windows except the rear window of the Convertible; this remains plain, untinted glass. In addition to the tinting, the upper portion of the Soft Ray windshield is shaded.

The properties of Soft Ray Glass absorb some of the infra-red solar heat rays. This has the effect of rejecting a percentage of heat radiation and not allowing it to enter the car.

Soft Ray Glass is recommended whenever Comfort Control or Air Conditioning is ordered.

REAR WINDOW DEFOGGER

This accessory is available for dealer installation and may be ordered through your Cadillac Parts Department. Do not specify on new car orders.

RADIO FOOT SELECTOR CONTROL

A foot selector control for the signal seeking radio may be procured through your Cadillac Parts Department for local installation. It cannot be supplied in production.

PACKAGED ACCESSORIES

See page 36 for a list of packaged accessories available through your Cadillac Parts Department for dealer installation.

TIRES

		OPTIONAL—WHITE WALL					STANDARD—BLACK	
		129.5"-133" Wheelbase Cars	149.8" Wheelbase Cars				129.5"-133" Wheelbase Cars	149.8" Wheelbase Cars
SIZE		9.00-15	8.20-15				8.00-15	8.20-15
Brand	Code	Ply Rating	Ply Rating	Code	Ply Rating	Ply Rating		
Firestone	FW	4 <hr style="width: 50%; margin: 0 auto;"/> 6	8	F	4	8		
Goodrich	GW	4	8	G	4	8		
U.S. Royal	UW	4	8	U	4	8		
Goodyear	YW	4		Eldorado standard equipment includes 9.00-15, 4-ply white wall tires.				
Makes Not Optional		One of the four tire makes shown on chart above will be furnished without option depending upon availability at time of car assembly.						
Do Not Specify Codes		<i>The tire codes on the chart are for record purposes only and should not be specified on new car orders (except W, see below). The codes will appear only on Notice Of Car Shipment which is mailed to dealers after the car is shipped.</i>						
All Makes Not Always Available		It is recognized that a tire option would be desirable to accommodate customers who may have a preference; however, production complexities make impossible a constant inventory of all makes, colors and sizes.						
How To Order White Wall Tires		If group 1, 2, 3 or 4 is not ordered and white wall tires are wanted, type W in space captioned groups.						
8 & 6 Ply Rating Sizes Not Interchangeable		Tire sizes 8.20-15, 8 ply rating and 9.00-15, 6 ply rating are not interchangeable. Therefore, the 9.00 size cannot be furnished on Fleetwood Seventy-Five and 8.20 will not fit the 129.5" and 133" wheelbase cars. Extra charge for 9.00-15, 6 ply Firestone white wall tires \$144.37.						
Exclusive Cadillac Size And Design		The new 9.00-15 size triple-white sidewall tires made expressly for Cadillac have improvements that include finer tread elements, rounded shoulders and a balanced profile which contribute to better handling, cornering and improved traction.						
9.00 Size Recommended With Comfort Control		On 129.5" and 133" wheelbase Comfort Control equipped cars, size 9.00-15 white wall tires are recommended. The larger tire size is advisable because of the additional weight of air conditioning.						
Spare Tire Location		The spare tire is carried in center of trunk compartment over axle hump, except in Convertible and Fleetwood Seventy-Five models. In these four styles, it is on right side of trunk floor.						

SEAT ADJUSTERS

BODY STYLES	STANDARD BENCH SEAT			BUCKET SEATS		
	2-WAY MANUAL	2-WAY POWER	CODE Y	2-WAY POWER (DRIVER)	2-WAY POWER (PASSENGER)	CODE T
			6-WAY POWER			4-WAY POWER (DRIVER)
Calais Series Styles G-N-K	Std.	N/A	Opt.	N/A	N/A	N/A
De Ville Series Styles F-J-B-L	N/A	Std.	Opt.	Std.	Std.	Opt.
Eldorado Convertible Style E	N/A	N/A	Std.	N/A	Std.	Std.
Sixty Special Style M	N/A	Std.	Opt.	N/A	N/A	N/A
Seventy-Five Styles R-S	N/A	Std.	N/A	N/A	N/A	N/A

CODES

Y—6-Way power bench seat.
T—4-Way power driver's bucket seat.

ROTARY SWITCH

A Cadillac exclusive!

The power 6-way bench type seat adjuster switch is now located at lower left side of seat. A lever control with a rotary action tilts the seat forward or backward. It also provides for normal fore, aft and up and down movement.

The tilting action is accomplished by rotating the lever clockwise to tilt seat backward and counter clockwise for forward tilting.

SWITCH LOCATIONS

All front seat adjuster controls are located at lower left side of seat except: passenger bucket seat control is on right side; Seventy-Five models is under lower instrument panel.

DRIVER'S BUCKET SEAT ADJUSTERS

2-Way power adjuster is standard on driver's bucket seat except Eldorado which has a 4-way power adjuster as standard.

4-Way power adjuster is optional on all other driver's bucket seats.

A 2-way or 4-way toggle switch is located at left side of seat.

PASSENGER BUCKET SEAT ADJUSTER

2-Way power adjuster is standard on all right side bucket seats.

A 4-way adjuster is not available for the passenger bucket seat.

A 2-Way toggle switch is located at right side of seat.

SEAT BELTS

NEW RETRACTORS

New plastic covered retractor assemblies are used on the front outboard seat belts. The plastic housing has a simulated leather grain and matches the carpet color. Fleetwood Seventy-Five front seat belts are anchored without retractors. However, the belts and buckles are the same.

NEW BUCKLES

The buckle release has a push-button action. Depressing a plate lever located under a squared circle opening, unlocks the buckle and permits separating the straps.

This exclusive Cadillac seat belt buckle is chrome finished and includes a Cadillac crest on the release plate.

11 COLORS

Seat belt webbing colors match the bolsters as listed on interior charts except:

Code 210 and 310 will have black belts.

Sandalwood or Beige upholstery will have light beige belts.

Code 461 will have light blue belts.

Code 719 will have light gray belts.

White leather upholstery will have belts in color to match the carpets.

REAR SEAT BELTS — CODE A

Seat Belts for two front compartment occupants are standard equipment on all cars. Two sets of seat belts for the rear compartment are optional equipment on all cars including the Fleetwood Seventy-Five. To order rear seat belts, use code A.

DELETION OPTION—CODE O

Code 0 covers a "Deletion Option" at reduced cost. When ordered, the two sets of standard front seat belts will be omitted.

Price information applicable to front seat belt deletion option. Manufacturer's Suggested Retail Price \$16.80 net.

MANUFACTURER'S SUGGESTED RETAIL PRICES

		CALAIS			DE VILLE		
		Coupe G	Hardtop Sedan N	Sedan K	Coupe J	Hardtop Sedan B	Sedan L
BASIC CAR <i>(includes E.O.H. and suggested delivery and handling charges)</i>		\$5059.00	\$5247.00	\$5247.00	\$5419.00	\$5666.00	\$5666.00
FIREMIST COLOR—Eldorado		134.40	134.40	134.40	134.40	134.40	134.40
PADDED ROOF OR BROUGHAM OPTION		N/A	N/A	N/A	123.65	139.75	139.75
LEATHER UPHOLSTERY— <i>Standard Options</i>					140.90	140.90	140.90
BUCKET SEATS— <i>With Std. Opt. Leather</i>		N/A	N/A	N/A	328.75	328.75	355.55
W	TIRES—White Wall (5)	57.45	57.45	57.45	57.45	57.45	57.45
8	LICENSE FRAME— <i>One</i>	5.85	5.85	5.85	5.85	5.85	5.85
9	LICENSE FRAMES— <i>Two</i>	11.70	11.70	11.70	11.70	11.70	11.70
F	FILLER PLATE	N/C	N/C	N/C	N/C	N/C	N/C
A	SEAT BELTS—2 Rear	18.30	18.30	18.30	18.30	18.30	18.30
X	WINDOWS—Power	118.45	118.45	118.45	STD.	STD.	STD.
R	RADIO—AM	164.60	164.60	164.60	164.60	164.60	164.60
R1	RADIO—AM-FM	191.40	191.40	191.40	191.40	191.40	191.40
R2	RADIO—Rear Control (AM)	N/A	N/A	N/A	N/A	N/A	N/A
E	GLASS—Soft Ray	51.70	51.70	51.70	51.70	51.70	51.70
Y	SEAT ADJUSTER—6-Way Front	113.05	113.05	113.05	85.05	85.05	85.05
T	SEAT ADJUSTER—4-Way Driver's Bucket	N/A	N/A	N/A	53.65	53.65	53.65
D	DOOR EDGE GUARDS	4.05	7.30	7.30	4.05	7.30	7.30
K	COMFORT CONTROL (Air Conditioner)	494.50	494.50	494.50	494.50	494.50	494.50
U	HEADLAMP CONTROL—Guide-Matic	51.10	51.10	51.10	51.10	51.10	51.10
Q	STEERING WHEEL—Tilt & Telescope	91.40	91.40	91.40	91.40	91.40	91.40
M	DOOR LOCKS—Power	45.75	70.00	70.00	45.75	70.00	70.00
J	TWILIGHT SENTINEL	29.05	29.05	29.05	29.05	29.05	29.05
S	TRUNK LOCK—Remote Control	53.15	53.15	53.15	53.15	53.15	53.15
G	CONTROLLED DIFFERENTIAL	53.70	53.70	53.70	53.70	53.70	53.70
C	CRUISE CONTROL	96.60	96.60	96.60	96.60	96.60	96.60
N	VENT WINDOWS—Power	73.20	73.20	73.20	73.20	73.20	73.20
P	LEVEL CONTROL—Automatic	80.65	80.65	80.65	80.65	80.65	80.65

MANUFACTURER'S SUGGESTED RETAIL PRICES

FLEETWOOD						
De Ville Conver- tible F	Eldorado Conver- tible E	Sixty Special Sedan M	Seventy- Five Sedan R	Seventy- Five Limousine S		
\$5639.00	\$6738.00	\$6479.00	\$9746.00	\$9960.00	BASIC CAR <small>(includes E.O.H. and suggested delivery and handling charges)</small>	
134.40	STD.	134.40	134.40	134.40	FIREMIST COLOR—Eldorado	
N/A	N/A	198.90	537.50	537.50	PADDED ROOF OR BROUGHAM OPTION	
STD.	STD.	140.90	[Cross-hatched]		LEATHER UPHOLSTERY—Standard Options	
187.85	N/C	[Cross-hatched]	N/A	N/A	BUCKET SEATS—With Std. Opt. Leather	
57.45	STD.	57.45	64.75	64.75	W	TIRES—White Wall (5)
5.85	5.85	5.85	5.85	5.85	8	LICENSE FRAME—One
11.70	11.70	11.70	11.70	11.70	9	LICENSE FRAMES—Two
N/C	N/C	N/C	N/C	N/C	F	FILLER PLATE
18.30	18.30	18.30	18.30	18.30	A	SEAT BELTS—2 Rear
STD.	STD.	STD.	STD.	STD.	X	WINDOWS—Power
164.60	164.60	164.60	164.60	164.60	R	RADIO—AM
191.40	191.40	191.40	191.40	191.40	R1	RADIO—AM-FM
N/A	N/A	N/A	246.60	246.60	R2	RADIO—Rear Control (AM)
51.70	51.70	51.70	51.70	51.70	E	GLASS—Soft Ray
85.05	STD.	85.05	[Cross-hatched]		Y	SEAT ADJUSTER—6-Way Front
53.65	STD.	[Cross-hatched]	N/A	N/A	T	SEAT ADJUSTER—4-Way Driver's Bucket
4.05	4.05	7.30	7.30	7.30	D	DOOR EDGE GUARDS
494.50	494.50	494.50	623.70	623.70	K	COMFORT CONTROL (Air Conditioner)
51.10	51.10	51.10	45.75	45.75	U	HEADLAMP CONTROL—Guide-Matic
91.40	91.40	91.40	N/A	N/A	Q	STEERING WHEEL—Tilt & Telescope
45.75	45.75	70.00	161.25	161.25	M	DOOR LOCKS—Power
29.05	29.05	29.05	29.05	29.05	J	TWILIGHT SENTINEL
53.15	53.15	53.15	N/A	N/A	S	TRUNK LOCK—Remote Control
53.70	53.70	53.70	53.70	53.70	G	CONTROLLED DIFFERENTIAL
96.60	96.60	96.60	96.60	96.60	C	CRUISE CONTROL
73.20	STD.	STD.	73.20	73.20	N	VENT WINDOWS—Power
80.65	STD.	STD.	N/A	N/A	P	LEVEL CONTROL—Automatic

INTERIOR INFORMATION CHARTS

Fabrics and Colors

Charts in this section list by body style the type of fabrics and colors that apply to each upholstery code number.

Illustrations of Trim Styles and Materials

Perspective drawings on the inside of folded pages illustrate the trim styles and materials used for the various components of the interior. These can be helpful in describing special interior specifications and to explain details of material distribution to interested customers. For example, leather implies the use of vinyl on certain areas. The illustrations depict these leather and vinyl sections. Extra copies of drawings are available upon request for ordering special combinations which may be intricate or difficult to describe verbally.

Trim Styles Not Interchangeable

There are eight separate upholstery stylings used in the eleven body styles and they are not interchangeable. Each style is designed for certain models and materials and cannot be adapted to other body types. For example, a de Ville or Fleetwood Sixty Special cannot be made in the Eldorado pleated mode. The patterns and molded components are of different sizes and forms, according to the requirements of the body into which the upholstery is to be installed. Some parts such as rubber seat pads, which are machine-formed have indentations molded especially for sewing the pleats. These are examples of the limitations that preclude any option of trim style.

Front Seat Location

All front seats with bench type cushions (except Fleetwood 75) have two holes in each of the four attachment brackets that anchor the seat to the floor. These holes are about one inch apart and designed to provide an optional front seat location. At the factory the seat is positioned in the rear holes. However, if additional leg room is desired the seat may be relocated rearward by removing the four studs and bolting them through the front holes. Although this cannot be done in production at the factory, it is a simple procedure for any service department to perform.

COLORS OF AVAILABLE INTERIOR COMPONENTS

CLOTH	C O D E	LEATHER	C O D E	CARPETS	TOP OF INSTRUMENT PANEL	CENTER INSTRUMENT PANEL	LOWER INSTRUMENT PANEL	STEERING WHEEL
Black	10 11	Black	51	Black	Black	Black	Black	Black
		White	52-3 54-5			White	White	White
Gray	16 18 19	Gray	56	Med. Gray	Dk. Gray	Gray	Gray	Gray
				Dk. Gray				
Blue	20 21	Blue	60	Med. Blue	Dk. Blue	Blue	Blue	Blue
Midnight Blue	26	Midnight Blue	66	Midnight Blue	Midnight Blue	Midnight Blue	Midnight Blue	Midnight Blue
Turquoise	28	Turquoise	68	Med. Turquoise	Dk. Turquoise	Turquoise	Turquoise	Turquoise
Green	30	Green	70	Med. Green	Dk. Green	Green	Green	Green
Sandalwood	41	Sandalwood	81	Med. Sandalwood	Dk. Sandalwood	Sandalwood	Sandalwood	Sandalwood
Beige	44	Beige				Beige	Beige	Beige
Bronze	46	Bronze	86	Dk. Bronze	Dk. Bronze	Med. Bronze	Med. Bronze	Med. Bronze
		Tan	83	Med. Tan	Med. Tan	Tan	Tan	Tan
		Red	88	Dk. Red	Dk. Red	Red	Red	Red
		Gray-Blue	61	Dk. Gray-Blue	Dk. Gray-Blue	Gray-Blue	Gray-Blue	Gray-Blue
		Blue-Green	76	Dk. Blue-Green	Dk. Blue-Green	Blue-Green	Blue-Green	Blue-Green

LEATHER OPTIONS

13 Colors. Including the four regular production colors offered on de Ville Coupe, Hardtop Sedan, Sedan and Fleetwood Sixty Special (styles J, B, L and M), there are 13 leather colors available as special order options on any model. Prices are on next page. For details of color distribution refer to interior charts.

Leather Codes. The first digit of upholstery codes represents the series of car. Second and third numbers are the color. Use the code numbers according to model. For example, 483 is Tan leather in an Eldorado. If Tan leather is wanted in a de Ville, the number will be 383; in a Calais series 283. The leather in all cars is the same but the prices vary according to series of car. Please use the code numbers as listed on next page.

Eldorado Leather. There is no difference between the quality of Eldorado leather and that used in the de Ville series or Fleetwood Sixty Special. All Cadillac leather is the same finest quality. However, in the Eldorado the seats are all leather instead of a combination with coated fabric. Therefore, customers who may desire a premium-priced full leather upholstery similar to the Eldorado can specify "All Leather" on the order. Extra charge for such special interiors will be quoted upon request.

Non-Perforated Leather. The leather used on bolster areas is non-perforated Antique finish, except Black and White which is natural grain. Upon request, this plain type of leather can also be substituted for the perforated Aztec grain inserts.

Style of Trim. Leather trim style is the same as the cloth combination on all models except the Fleetwood Sixty Special. In this model, the leather style has 1½" pleats which differs from either of the two cloth styles.

Trim styles are not interchangeable; the Calais series pleated styling cannot be used in a de Ville or vice versa. Eldorado seats are not interchangeable with the Coupe de Ville or Sixty Special, as the Convertible rear seat is narrower than the closed models. When an upholstery material of another series is ordered, the style will remain that of the body type into which it is being installed and not that from which it is taken. e.g., de Ville upholstery material ordered for style 68239 will be in the Calais series pleated method, not in the de Ville Y-seam and center button styling.

Leather Vs. Vinyl. To answer questions that may arise concerning the use of leather and vinyl, the following explanation may be of interest: interiors classified as leather include the use of coated fabric for certain areas. Such application is practical as there are advantages to both materials. The luxurious expanded vinyl type of coated fabrics used in Cadillac interiors have desirable characteristics such as abrasion resistance; they also blend with genuine leather surfaces without noticeable contrast.

Carpets. Trieste quality will be furnished in Calais series cars except codes 261, 286, 276, 283, and 288 will have Tremont. All other models will have Tremont quality.

Garnish Moldings. The metal moldings extending from the base of windshield pillar, along side of headlining and terminating at rear quarters, also around rear window will be finished as follows:

Calais Series. Painted to match lower instrument panel if it is one of the standard Calais series colors. Otherwise the garnish moldings will be in bright metal.

DeVille Series. Bright metal.

Fleetwood Sixty Special. Painted to match lower instrument panel.

SPECIAL LEATHER COMBINATIONS AND PRICES

Body Styles	Calais G-N-K		de Ville J-B-L		Fleetwood Sixty Special M		de Ville Convertible F		Eldorado Convertible E	
	Code	M.S.R. Price	Code	M.S.R. Price	Code	M.S.R. Price	Code	M.S.R. Price	Code	M.S.R. Price
Black	251	\$322.50								
White with *Black Carpets	252	"								
White with *Red "	254	"								
White with *Blue "	253	"							453	\$10.75
White with *Turquoise "	255	"							455	10.75
Sandalwood	281	"								
Red	288	"								
Gray	256	"	356	236.50	056	215.00	356	\$86.00	456	59.15
Blue	260	"	360	"	060	"			460	"
Midnight Blue	266	"	366	"	066	"	366	86.00	466	"
Turquoise	268	"	368	"	068	"	368	"	468	"
Green	270	"	370	"	070	"			470	"
Tan	283	"	383	"	083	"				
Bronze	286	"	386	"	086	"			486	59.15
Gray-Blue	261	"	361	"	061	"	361	86.00		
Blue-Green	276	"	376	"	076	"	376	"		

*Top of Instrument Panel will match carpets. Shaded areas are standard options.

LEATHER TRIM CODES. The first number denotes series; second and third the color. Certain numbers such as 368, 466 and those starting with 2 are not in upholstery sample book as a 3 digit number. To determine color, refer to second and third digits only.

GEAR RATIOS

WHEELBASE	STANDARD	OPTIONAL	ORDER CODES	MANUFACTURING CODES	
				REGULAR DIFFERENTIAL	CONTROLLED DIFFERENTIAL
129.5" & 133" with C/C	3.21-1	None		1	G1
129.5" & 133" without C/C	2.94-1			2	G2
192.5" & 133" without C/C		3.21-1	1	1	G1
149.8" with or without A/C	3.36-1			6	G6
149.8" with or without A/C		3.77-1	7	7	G7

Abbreviations: C/C—Comfort Control A/C—Air Conditioner

ORDER CODES

Codes 1 or 7 Only are to be used in ordering optional ratios. i.e., to order 3.21-1 ratio, type 1 on order form in column captioned OPT. GEAR RATIO. The other three numbers are standard and, therefore, need not be specified. They are for manufacturing purposes as explained below.

MANUFACTURING CODES

A code symbol denoting axle gear ratio and Controlled Differential (if car is so equipped) is stamped on carrier housing on top of oil return hole just below flange yoke. These codes will appear on salmon notice of shipment copy, but unless option 1 or 7 is wanted (as explained above) they are not to be marked on new car orders.

WHY OTHER RATIOS NOT OPTIONAL

2.94-1 gear ratio is not optional on Comfort Control equipped cars, as it would cause the engine and compressor to operate slower. This would result in less air conditioning capacity, a reduction of car performance and getaway power.

3.36-1 is not recommended on 129.5" and 133" wheelbase cars as it would disturb the balance inherent in the design causing needless wear, extra fan noise, additional fuel consumption and excessive speed of the long propeller shaft.

3.77-1 is optional only in the Fleetwood Seventy-Five models.

INSTRUMENT PANEL DESIGN

Three separate sections comprise the new instrument panel and padded cover. They are called:

1. Top — Instrument Panel
2. Center — Instrument Panel
3. Lower — Instrument Panel

To maintain interior harmony, whenever the color of any one of the three sections of the instrument panel is changed — as in a two-tone combination — the adjoining door and rear quarter components must also be changed.

TOP OF INSTRUMENT PANEL

To reduce glare, the foam cushioned instrument panel top is covered with a dark tone low gloss material. White or light colors cannot be used for safety reasons. Except in white leather combinations, the dark top of instrument panel color is used on the upper part of the doors, rear quarters and shelf. This forms a dark tone belt line from windshield to rear window.

CENTER INSTRUMENT PANEL

This area, between the dark tone padded top cover and lower instrument panel, is made of fiberglass reinforced thermoplastic. It has a crush grain texture surface which is painted in color to match the seat inserts on standard black-white and special two-tone interiors. On all other combinations it will harmonize with the bolster color. A section on the door, above the arm rest and surrounding the inserts, will also be in this color.

LOWER INSTRUMENT PANEL

This is the bottom of the panel assembly which includes the glove box door. It is made of the same material as the center part including the crush grain texture. The color matches the door side arm rest.

INSERTS

Integral with the lower instrument panel are three sections that have facings or inserts. Two, on which the windshield wiper, Comfort Control or heater controls are mounted, are located on either side of the steering column. The third is the ash tray door which is centered in the panel above the glove box door. The facing materials covering these areas are:

SERIES	STYLES	FACING
Calais	G N K	Vinyl matching the lower instrument panel color.
De Ville	F J B L	Brushed stainless steel.
Fleetwood	E M	Tamo Wood Veneer.

CONCLUSION

Why Special? No matter how seemingly minor, any deviation from a standard trim combination makes necessary the removal of the entire order from regular production for individual handling. This is due to the intricate patterns from which multiple sets of components are cut, making it impossible to change or substitute just one part or section such as a seat bolster, carpet or top boot without tailoring the complete interior on a special order basis.

Matching Materials. To assure color harmony, the fabric parts for an entire interior are cut from the same roll or piece of material. Each part is then "pin-tagged" so that after being routed through separate sewing and trimming operations, all sections are ultimately combined with their matched mates as originally cut from the same bolt of material. This intricate procedure explains why, for example, a set of trim stock already started cannot have any changes. It must flow through the production process to prevent a mis-match of shades by combining components from different rolls of cloth.

Customer Choice. Because the entire order must be handled as a "special", the customer should be encouraged to choose all details of the made-to-order interior. The charge will usually be the same, whether a single item is changed or if several variations are made. At the same time, the customer should be guided with emphatic recommendations to select harmonious colors which will result in a muted combination. Generally, this is more pleasing than sharply contrasting colors, especially if more than two shades are selected.

Allowing customers to participate in the selection of special interior components will increase their appreciation of the completed combination, because it was their personal creation. Also, clarifying each part at the time of ordering will prevent possible misunderstanding upon delivery. The fact that an individually styled interior is wanted indicates the discriminating nature of the purchaser who is likely to have definite opinions regarding the treatment of the entire custom arrangement.

Understanding Of Costs. Sometimes a customer's conception of modern production methods is at variance with actual practice. This may result in a misunderstanding as to the value and charge for a seemingly small deviation from a standard combination. This customer reaction can be corrected if properly explained. Primarily, the extra cost is incurred by the necessity of hand-cutting materials singly instead of in multiple sets of four or more at once. Unless at considerable volume, the charge for any commodity increases and may seem unreasonable. The convertible top boot, for example, is part of the car's interior upholstery combination. It matches the bolster area of the seats and not the top material itself. As such, it is included with the fabrication of the car's complete interior trim. In order to change the color of the boot, the entire trim assembly must be taken out of the regular production pattern and hand-cut on a single order basis. Thus, the efficiency of modern production methods — which utilize time and material to the best advantage — is disrupted with a resulting higher cost for special handling.

NEW FOR 1965

FLEETWOOD SIXTY SPECIAL WHEELBASE is 133" — an increase of 3½". The overall length is 4" longer.

OVERALL LENGTH has been increased ½" on all other models except Fleetwood Seventy-Five.

LEATHER OPTIONS are now available for the Sedan de Ville, style L.

FOUR CARPET COLOR OPTIONS (including matching top of instrument panel) are available with white leather on de Ville and Sixty Special models.

TWENTY-SIX ADDITIONAL INTERIOR OPTIONS for a total of 150.

PADDED ROOF OPTION is now available on the Sedan de Ville, style L. The Fleetwood Sixty Special has a *Brougham* Option.

POWER DOOR LOCKS operate with door key, in addition to front door lock knobs and handles.

AUTOMATIC LEVEL CONTROL is a new air-controlled rear leveling ride system.

TILT AND TELESCOPE STEERING WHEEL.

CRUISE CONTROL has "automatic engage" feature.

DUAL RANGE TURBO HYDRA-MATIC TRANSMISSION is standard in all cars including Calais, Seventy-Five and Commercial Chassis. Transmissions with a variable pitch stator are in all cars except the Fleetwood Seventy-Five and Commercial Chassis which have a fixed stator.

REAR SEAT BELTS on Fleetwood Seventy-Five models are available for factory installation.

TIRE SIZE is 9.00-15 balanced profile.

CALAIS series is the designation for the previous series Sixty-Two.

CALAIS COUPE, style G, has front center arm rest instead of rear.

TWO DISTINCTIVE TRIM STYLES are available in Fleetwood Seventy-Five.

GLASS REAR WINDOW in convertibles.

HARDTOP designates Sedan models without body center pillar above belt line. However, the three Sedan style numbers ending in 69 have a thin center pillar extending from belt line to roof.

STYLE NUMBERS now have five digits.

UPHOLSTERY CODE NUMBERS now have three digits.

ENGINE OR SERIAL VEHICLE IDENTIFICATION NUMBERS are composed of one letter and seven numbers representing series, body type, model year and sequential number. e.g., N5100001.

CURVED GLASS in windows.

BODY DESIGN is completely changed.

Foreword

This Shop Manual has been prepared by the Service Department of the Cadillac Motor Car Division to aid Servicemen in servicing 1965 model Cadillac automobiles.

The manual is intended primarily for Servicemen who are familiar with earlier model Cadillacs. It includes complete information on service procedures and specifications pertaining to all 1965 model Cadillac cars except the Fleetwood Seventy-Five Sedan and Limousine. Only supplemental service information is provided in this manual on these vehicles. Refer to the 1964 Cadillac Shop Manual for service information pertaining to the Fleetwood Seventy-Five Sedan and Limousine other than that covered in this manual.

Arrangement of the Manual

The front page of this 1965 Manual contains a rapid reference section index with headings corresponding to the page tabs at the beginning of each section. A complete alphabetical index is located at the back of the manual.

The individual sections include a general description of components, service adjustment and replacement procedures, diagnosis information, and clearly identified illustrations. An illustrated list of special tools, a torque tightness chart, and specifications are also provided.

The electrical section of this manual is divided into sub-sections covering Cruise Control, Guide-Matic Power Headlight Control, Radio and Antenna, and Twilight Sentinel. A separate table of contents is provided at the beginning of this section to enable Servicemen to locate specific electrical service data more quickly.

The body section of this manual covers general information, body lubrication points, and replacement procedures for certain Cadillac-furnished items in the windshield area for all 1965 model Cadillac cars except the Fleetwood Seventy-Five Sedan and Limousine. Body service information is published in a separate manual, the "1965 Cadillac Body Service Manual." This manual, however, does not include body service information on Fleetwood Seventy-Five Sedans and Limousines. Refer to the 1964 Cadillac Shop Manual for body information on these vehicles.

GENERAL DESCRIPTION AND SPECIFICATIONS

Description	Style Number	Sales Code	Vehicle Identification Number	Wheelbase (Inches)	Overall Length (Inches)	Height (Inches)	Maximum Width (Inches)
Fleetwood Sixty Special Sedan (Fleetwood Brougham option)	68069	M	M5100001	133.0	227.5	55.8	79.7
Calais Hardtop Sedan	68239	N	N5100001	129.5	224	54.5	79.7
Calais Coupe	68257	G	G5100001	129.5	224	54.5	79.7
Calais Sedan	68269	K	K5100001	129.5	224	55.6	79.7
Hardtop Sedan de Ville	68339	B	B5100001	129.5	224	54.5	79.9
Coupe de Ville	68357	J	J5100001	129.5	224	54.5	79.7
De Ville Convertible	68367	F	F5100001	129.5	224	55.6	79.7
Sedan de Ville	68369	L	L5100001	129.5	224	54.5	79.7
Fleetwood Eldorado Convertible	68467	E	E5100001	129.5	224	55.6	79.7
Fleetwood Seventy-Five Sedan	69723	R	R5100001	149.8	243.8	59.0	79.9
Fleetwood Seventy-Five Limousine	69733	S	S5100001	149.8	243.8	59.0	79.9
Commercial Chassis	69890	Z	Z5100001	156.0	249.5	--	--

GENERAL INFORMATION

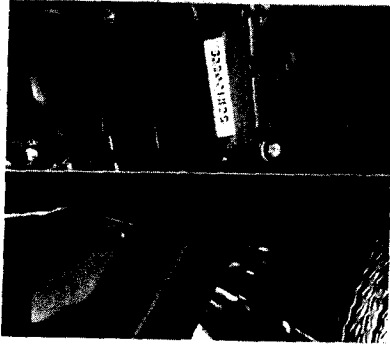

VEHICLE IDENTIFICATION NUMBER LOCATED ON REAR PORTION OF BLOCK BEHIND LEFT CYLINDER BANK AND ON TOP SURFACE OF LEFT FRAME SIDE RAIL.

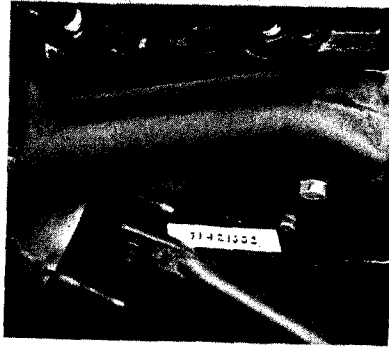

ENGINE UNIT NUMBER LOCATED BELOW REAR WELCH PLUG ON LEFT SIDE OF ENGINE.

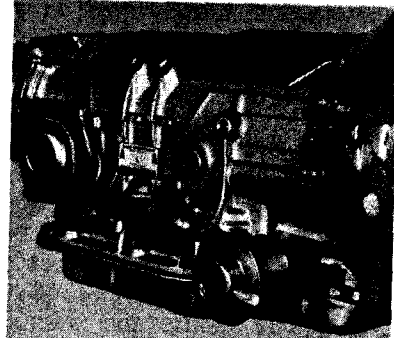

TURBO HYDRA-MATIC TRANSMISSION UNIT NUMBER PLATE LOCATED ON RIGHT SIDE OF CASE.

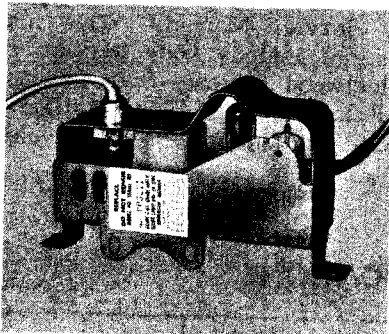

GUIDE MATIC AMPLIFIER SERIAL NUMBER LABEL LOCATED ON BOTTOM FACE OF UNIT.

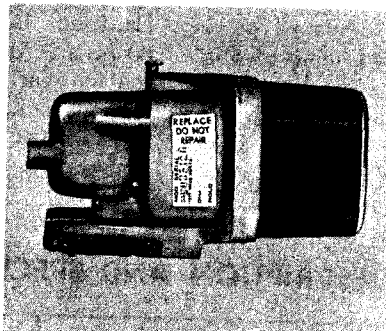

GUIDE MATIC PHOTOTUBE SERIAL NUMBER LABEL LOCATED ON TOP OF UNIT.

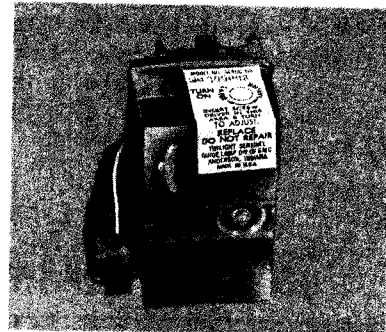

TWILIGHT SENTINEL AMPLIFIER SERIAL NUMBER LABEL LOCATED ON COVER OF UNIT.

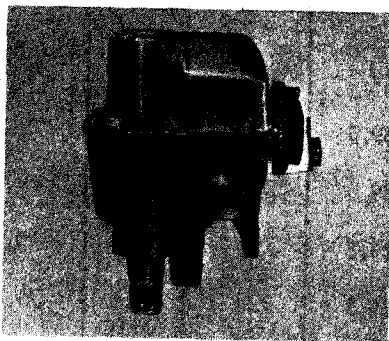

CRUISE CONTROL SERIAL NUMBER TAG ATTACHED TO REAR FACE OF HOUSING ASSEMBLY.

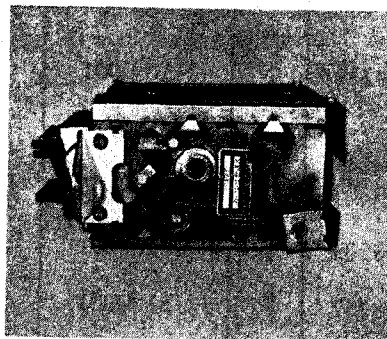

RADIO SERIAL NUMBER TAG LOCATED ON RIGHT SIDE OF TUNER.

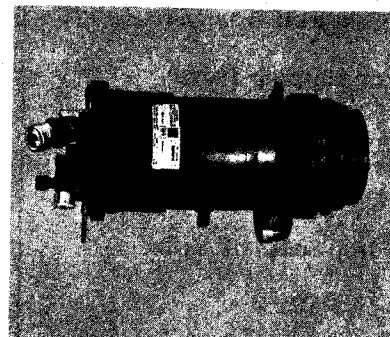

A/C COMPRESSOR SERIAL NUMBER LABEL LOCATED ON REAR PORTION OF COMPRESSOR HOUSING.

Fig. 1-1 Unit Number Locations

SERVICE INFORMATION

Three standard series of cars with eleven body styles are included in the 1965 Cadillac line. In addition, there is a Commercial Chassis. The numeral six is used as the first digit in designating all 1965 Cadillac body style numbers. The first three digits of the body style number indicate the series designation. Specifications are as shown on page 1-1.

Vehicle Identification Number

Each Cadillac automobile or chassis carries a Vehicle Identification Number. The number is used in license and insurance applications and in general reference to the automobile. The letter indicates the body style, the first digit of the number indicates the model year, and the last six digits indicate the sequence in which the car was built (see Page 1-1). The last six digits of the first 1965 model automobile manufactured is number 100001, regardless of series or style, and subsequent cars built are numbered in numerical order. Vehicle Identification Number locations are shown in Fig. 1-1.

Engine Unit Number

Each Cadillac engine carries an engine unit number prefixed by the numeral "5", designating the model year. The last six digits indicate the sequence in which the engine was built, regardless of type, starting with 000001. The letters L.C. are added immediately following the engine unit number on all engines built to low compression specifications. Production engines using .010 inch oversized pistons may be identified by an asterisk stamped on the block following the engine unit number. The location of this number is shown in Fig. 1-1.

Identification Numbers

Locations of identification numbers on various units are shown in Fig. 1-1. The identification number on the unit should always appear on forms sent to the Central Office such as PIR's, Claim Tags, Pre-Delivery Reports and, when required, on AFA's. The Vehicle Identification Number, the engine unit number and the transmission unit number are particularly important when reporting product information on these components.

GENERAL INFORMATION

Complete instructions for lubrication of the various points of the 1965 Cadillac car are described under Service Information in this section. An Engine Oil Change Interval and Viscosity Chart, and a Fluid Capacity Chart appear at the end of this section.

The Maintenance Schedule, Page 2-8 is based upon service at time of engine oil change, unless otherwise specified. The recommended engine oil change interval, regardless of season, is every 60 days or 6,000 miles, whichever occurs first.

More frequent changes are required with stop and go operation, prolonged idling periods, dusty road travel, or during extended cold or wet climatic conditions. In such cases, an oil change is recommended after 2,000 or even 1,000 miles of driving.

The front suspension spherical joints do not require periodic maintenance. The seals, however, should be inspected for physical damage or cracks each time the engine oil is changed. If this inspection is neglected, water and dirt may enter the joint through a leaking seal and cause the joint to become noisy. It will then be necessary to replace the seal and repack the joint.

The inner and outer tie rod pivot spherical joint seals should also be inspected for physical

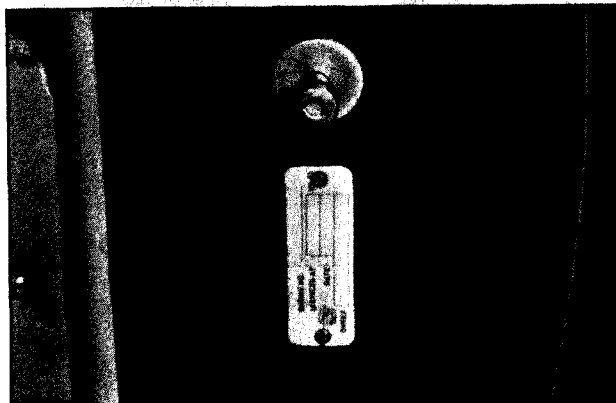

Fig. 2-1 Service Notice Plate

damage each time the engine oil is changed. At the same time the steering linkage joints should be checked for looseness. In the event a seal is found damaged or a joint loose, the affected inner or outer tie rod pivot should be replaced.

A Service Notice plate, Fig. 2-1, is attached to the front face of the left door lock pillar. The mileage and date at which the engine oil is changed and maintenance operations are performed should be posted on this plate. The Vehicle Identification number is printed on this plate, and a space is also provided to enter the owner's name.

SERVICE INFORMATION—LUBRICATION

1. Chassis

The various points on the chassis that require lubrication are listed in the Maintenance Schedule, Page 2-8. Lubrication should be performed according to the intervals specified on the schedule. Use factory recommended fluids in the quantities specified.

Spherical joints are used on the front suspension at the outer ends of the upper and lower control arms, and at the inner and outer steering linkage tie rod pivots.

The front suspension spherical joints should not need repacking throughout their entire service life under normal driving conditions. At the time of an engine oil change, visually inspect all joint seals for any indication of damage, such as cuts, tears, ruptures, worn spots, etc. If a damaged seal is evident, the seal must be replaced and the joint repacked.

The inner and outer steering linkage tie rod pivots do not need repacking throughout their service life. Whenever engine oil is changed,

the seals should be inspected for physical damage. Also, the linkage joints should be checked for looseness. If the seal is damaged or a joint loose, replace the affected inner or outer tie rod pivot.

Special front suspension lubricant is provided in one pound cans and is available from Parts Warehouses. This lubricant is identified by Part Number and the red colored label on the container. Repacking guns used with the lubricant have a red color band around the bottom of the body cylinder.

The procedure for replacing and repacking the upper and lower suspension arm spherical joint seals is described in Section 4 Notes 11 and 12.

2. Engine

a. Engine Oil Recommendations

The original factory fill oil will perform satisfactorily during the normal change interval specified on the Engine Oil Change Interval and

**EXTERIOR COLOR COMBINATIONS
1965 MODEL
ACRYLIC PAINT**

BODY, SHEET METAL AND MOLDING INSERT AREA

Reference should be made to the Stock No. when ordering refinishing materials.

(X) Comb. Color Code No.	Color	Original Color No.	Mfgr.	(Stock No.) R-M	(Stock No.) Dupont	(Stock No.) Ditzler
10	Sable (Black)	710-360	• Forbes	A-946	88	DDL-9400
12	Aspen White	L-55-W001	R-M	A-1522	4405-L	DDL-8356
16	Starlight Silver	720-399	• Forbes	A-1708	4621-L	DDL-32449
18	Ascot Gray	L-58-A 020	R-M	A-1694	4674-L	DDL-32474
20	Hampton Blue	L-58-B 036	R-M	A-1695	4675-L	DDL-13028
24	Tahoe Blue	L-58-B 037	R-M	A-1696	4676-L	DDL-13029
26	Ensign Blue	L-58-B 038	R-M	A-1697	4677-L	DDL-13030
28	Alpine Turquoise	867-97308	Dupont	A-1700	4680-L	DDL-43386
30	Cascade Green	L-58-G 024	R-M	A-1698	4678-L	DDL-43383
36	Inverness Green	L-58-G 025	R-M	A-1699	4679-L	DDL-43384
40	Cape Ivory	L-55-Y009	R-M	A-1701	4681-L	DDL-81494
42	Sandalwood	710-408	• Forbes	A-1702	4682-L	DDL-22554
44	Sierra Gold	L-58-N 019	R-M	A-1627	4566-L	DDL-22412
46	Samoan Bronze	867-97312	Dupont	A-1704R	4684-L	DDL-22557
48	Matador Red	867-96263	Dupont	A-1534R	4403-LM	DDL-71339
49	Claret Maroon	867-97311	Dupont	A-1703M	4683-LM	DDL-50696
90	Peacock Firemist	L-58-B 039	R-M	A-1706F	4686-L	DDL-13031
92	Sheffield Firemist	L-58-A 013	R-M	A-1705F	4685-L	DDL-32459
96	Jade Firemist	L-58-B 040	R-M	A-1707F	4687-L	DDL-43385
97	Saddle Firemist	L-58-N 014	R-M	A-1622F	4579-LH	DDL-22422
98	Crimson Firemist	L-58-R 008	R-M	A-1624F	4580-LM	DDL-71413

(X) Color Code Combination will be found stamped on Body Plate on Cowl.

- Ditzler supplier for Forbes refinishing materials.

Application of Code Numbers: Examples

Example 1: Paint Code 1012 (Two Tone).

The first two digits (10) indicate the lower exterior color (Black).

The last two digits (12) indicate the upper exterior color (Aspen Black).

Example 2: Paint Code 10 (Single Tone). Indicates entire exterior is painted (Black).

WHEELS

Color Name

Lt. Gray

Matching Color No.

1323 (Dupont)

INTERIOR COLORS—SEE CHARTS ON FOLLOWING PAGES

TRIM CODE COLOR REFERENCE CHART

Reference Chart for Determining Paint Colors on Interior Parts from the Paint Charts by Trim Code No. (Trim Code No. is stamped on Metal Plate Attached to Left Side of Cowl Under Hood near Hood Hinge).

Style 65-68069

011	Black (Cloth) w/Black (Leather)
016	Lt. Gray (Cloth & Leather)
018	Lt. Gray (Cloth)
020	Lt. Blue (Cloth & Leather)
021	Lt. Blue (Cloth)
026	Midnight Blue (Cloth)
028	Lt. Turquoise (Cloth & Leather)
030	Lt. Green (Cloth)
041	Lt. Sandalwood (Cloth & Leather)
044	Lt. Beige (Cloth)
051	Black (Leather)
052	White (Leather)
053 (A)	White (Leather) w/Med. Blue Carpet & Dk. Blue
054 (B)	White (Leather) w/Dk. Red Carpet & Dk. Red
055 (A)	White (Leather) w/Med. Turquoise Carpet & Dk. Turquoise
081	Lt. Sandalwood (Leather)
088	Med. Red (Leather)

NOTE: (A) Instrument Panel Cover and Extension, and Rear Package Shelf - Trim 053, 055.
 (B) Instrument Panel Cover and Extension, Door and Rear Quarter Belt Trim, and Rear Package Shelf - Trim 054.

Styles 65-68239,57,69

210	Black (Cloth) w/White (Coated Fabric)
216	Lt. Gray (Cloth) w/Lt. Gray (Coated Fabric)
220	Lt. Blue (Cloth) w/Lt. Blue (Coated Fabric)
226	Midnight Blue (Cloth) w/Midnight Blue (Coated Fabric)
228	Lt. Turquoise (Cloth) w/Lt. Turquoise (Coated Fabric)
230	Lt. Green (Cloth) w/Lt. Green (Coated Fabric)
241	Lt. Sandalwood (Cloth) w/Lt. Sandalwood (Coated Fabric)

Styles 65-68339,57,69

310	Black (Cloth) w/White (Leather)
319	Dk. Gray (Cloth) w/Lt. Gray (Leather)
320	Lt. Blue (Cloth & Leather)
326	Midnight Blue (Cloth & Leather)
328	Lt. Turquoise (Cloth & Leather)
330	Lt. Green (Cloth & Leather)
341	Lt. Sandalwood (Cloth & Leather)
346	Dk. Bronze (Cloth) w/Med. Bronze (Leather)

Styles 65-68339,57

351, 351B	Black (Leather)
352, 352B	White (Leather)
353, 353B (A)	White (Leather) w/Med. Blue Carpet & Dk. Blue
354, 354B (B)	White (Leather) w/Dk. Red Carpet & Dk. Red
355, 355B (A)	White (Leather) w/Med. Turquoise Carpet & Dk. Turquoise

Styles 65-68339,57 (Cont'd)

381, 381B	Lt. Sandalwood (Leather)
388, 388B	Med. Red (Leather)

NOTE: (A) Instrument Panel Cover and Extension, and Rear Package Shelf - Trim 353, 353B, 355, 355B.
 (B) Instrument Panel Cover and Extension, Door and Rear Quarter Belt Trim, and Rear Package Shelf - Trim 354, 354B.

Style 65-68367

351, 351B	Black (Leather)
352, 352B	White (Leather)
353, 353B (A)	White (Leather) w/Med. Blue Carpet & Dk. Blue
354, 354B (B)	White (Leather) w/Dk. Red Carpet & Dk. Red
355, 355B (A)	White (Leather) w/Med. Turquoise Carpet & Dk. Turquoise
370, 370B	Lt. Green (Leather)
381, 381B	Lt. Sandalwood (Leather)
383, 383B	Lt. Tan (Leather)
386, 386B	Med. Bronze (Leather)
388, 388B	Med. Red (Leather)

NOTE: (A) Instrument Panel Cover and Extension, and Rear Package Shelf - Trim 353, 353B, 355, 355B.
 (B) Instrument Panel Cover and Extension, Door and Rear Quarter Belt Trim, and Rear Package Shelf - Trim 354, 354B.

Style 65-68467

451, 451B	Black (Leather)
452, 452B	White (Leather) w/Black Carpet
454, 454B	White (Leather) w/Red Carpet
461, 461B	Med. Gray-Blue (Leather)
476, 476B	Med. Blue-Green (Leather)
481, 481B	Lt. Sandalwood (Leather)
483, 483B	Lt. Tan (Leather)
488, 488B	Med. Red (Leather)

Style 65-69723

716	Lt. Gray (Cloth)
718	Lt. Gray (Cloth)
719	Med. Gray (Cloth)
726	Midnight Blue (Cloth)
744	Lt. Beige (Cloth)

Style 65-69733 Leather Front Compartment and Cloth Rear Compartment

716	Black (Leather) w/Lt. Gray (Cloth)
716G	Lt. Gray (Leather & Cloth)
718	Black (Leather) w/Lt. Gray (Cloth)
718G	Lt. Gray (Leather & Cloth)
719	Black (Leather) w/Med. Gray (Cloth)
719G	Lt. Gray (Leather) w/Med. Gray (Cloth)
726	Black (Leather) w/Midnight Blue (Cloth)
726M	Midnight Blue (Leather & Cloth)
744	Black (Leather) w/Lt. Beige (Cloth)
744F	Lt. Beige (Leather & Cloth)

INTERIOR COLOR COMBINATIONS 1965 MODEL

*CENTER AND LOWER INSTRUMENT PANEL, *STEERING COLUMN AND COVERS,
 ●GARNISH MOLDINGS, *SHIFT LEVER CARRIER AND SIGNAL SWITCH HOUSING,
 ●SEAT SIDE PANELS AND ●CONSOLE CASE.
 ●DOOR ARM RESTS 68239,57,69,75 — ●CLOCK AND ASH TRAY ESCUTCHEON 75.

NOTE (*) - 20° Gloss.
 (●) - 40° Gloss.

To Match Trim Code No.	Color	(Formula No.) Matching Colors
011,051,351,351B,451,451B,*716,*718,*719, *726,*744	Black.....	R - M Dupont Ditzler
*69733 style only.		400 88 DL-9248
016,016,216,319,*716,716G,*718,718G,*719,●719G	Lt. Gray.....	R - M Dupont Ditzler
*69723 style only. ●Exc. door arm rests, which are Med. Gray.		63C14 9002-L DL-32190
020,021,220,320	Lt. Blue.....	R - M Dupont Ditzler
*69723 style only.		65C16 9212-L DL-13054
026,226,326,*726,726M	Midnight Blue.....	R - M Dupont Ditzler
*69723 style only.		65C20 9219-L DL-13051
028,228,328	Lt. Turquoise.....	R - M Dupont Ditzler
		65C37 9215-L DL-43406
030,230,330,370,370B	Lt. Green.....	R - M Dupont Ditzler
		65C35 9213-I DL-43405
041,081,241,341,381,381B,481,481B	Lt. Sandalwood.....	R - M Dupont Ditzler
		65C84 9214-1 DL-22575
044,*744,744F	Lt. Beige.....	R - M Dupont Ditzler
*69723 style only.		65C87 9216-L DL-22578
052,053,054,055,210,310,352,352B,353,353B, 354,354B,355,355B,452,452B,454,454B	White.....	R - M Dupont Ditzler
		63C92 9023-L DL-8357
088,388,388B,488,488B	Med. Red.....	R - M Dupont Ditzler
		65C52 9218-LH DL-71489
383,383B,483,483B	Lt. Tan.....	R - M Dupont Ditzler
		65C83 9109-L DL-22286
346,386,386B	Med. Bronze.....	R - M Dupont Ditzler
		65C86 9217-L DL-22579
461,461B	Med. Gray Blue.....	R - M Dupont Ditzler
		65C29 9220-L DL-13049
476,476B	Med. Blue Green.....	R - M Dupont Ditzler
		65C33 9221-L DL-43404
*744	Lt. Beige.....	R - M Dupont Ditzler
*69723 style only.		65C87 9216-L DL-22578

INTERIOR COLOR COMBINATIONS 1965 MODEL

*RADIO SPEAKER, *COMFORT CONTROL SENSOR GRILLE, •BACK WINDOW
DEFROSTER GRILLE, AND •REAR SEAT BACK VALANCE 65-75.

NOTE (*) - 20° Gloss.
(•) - 40° Gloss.

To Match Trim Code No.	Color	(Formula No.) Matching Colors
011,051,052,210,310,351,351B,352,352B,451, 451B,452,452B,*716,*718,*726,*744	Black	R - M Dupont Ditzler 400 88 DL-9248
*69733 style only.		
016,018,216,319,*716,716G,*718,718G, *719,719G	Dk. Gray	R - M Dupont Ditzler 65C14 DL-32473
*69723 style only.		
020,053,220,320,353,353B	Dk. Blue	R - M Dupont Ditzler 64C12 DL-13053
026,226,326,*726,726M	Midnight Blue	R - M Dupont Ditzler 65C20 DL-13051
*69723 style only.		
028,055,228,328,355,355B	Dk. Turquoise	R - M Dupont Ditzler 65C39 DL-43403
030,230,330,370,370B	Dk. Green	R - M Dupont Ditzler 64C39 DL-43298
041,044,081,241,341,381,381B,481,481B, *744,744F	Dk. Sandalwood	R - M Dupont Ditzler 63C86 DL-22576
*69723 style only.		
088,354,354B,388,388B,454,454B,488,488B	Dk. Red	R - M Dupont Ditzler 65C51R DL-71436
346,386,386B	Dk. Bronze	R - M Dupont Ditzler 65C88
383,383B,483,483B	Med. Tan	R - M Dupont Ditzler 65C85 DL-22458
461,461B	Dk. Gray Blue	R - M Dupont Ditzler 65C27 DL-13050
476,476B	Dk. Blue Green	R - M Dupont Ditzler 65C34 DL-43407



1965 CADILLAC COLORS

- | | |
|--------------------------|-------------------------|
| 10..... Sable Black | 30..... Cascade Green |
| 12..... Aspen White | 38..... Inverness Green |
| 16..... Starlight Silver | 40..... Cape Ivory |
| 18..... Ascot Gray | 42..... Sandalwood |
| 20..... Hampton Blue | 44..... Sierra Gold |
| 24..... Tahoe Blue | 46..... Samoan Bronze |
| 26..... Ensign Blue | 48..... Matador Red |
| 28..... Alpine Turquoise | 49..... Claret Maroon |

ELDORADO FIREMIST COLORS

AVAILABLE ON OTHER BODY STYLES AT EXTRA CHARGE

- | | |
|----------------------------|-------------------------|
| 90..... Peacock Firemist | 96..... Jade Firemist |
| 92..... Sheffield Firemist | 97..... Saddle Firemist |
| 98..... Crimson Firemist | |

**The 1965 Cadillac is equipped
AT NO EXTRA COST
with**

- Back-up lights
- Cornering lights
- Door panel safety warning reflectors
- Electric clock
- Heater-defroster*
- Luggage compartment lights (automatic)
- Power brakes
- Power steering
- Rear-view, glareproof, flip-type mirror
- Remote-control outside mirror
- Shatterproof visor vanity mirror
- Sun visors (dual)
- Turbo Hydra-Matic transmission
- Windshield washer and coordinator

*Available without heater-defroster as a deletion option at reduced cost.

Cadillac Motor Car Division of General Motors Corporation reserves the right to make changes at any time, without notice, in prices, colors, materials, equipment, specifications and body styles, and also to discontinue body styles.

1965 Cadillac

MANUFACTURER'S SUGGESTED RETAIL PRICES

Issued September 24, 1964

Style No.	Body Style	Code	Manu- facturer's Suggested Retail Price*	Destination Charge To	Manu- facturer's Suggested Retail Price* Plus Destination Charge
68257	Calais Coupe	G	\$5,059.00	\$	\$
68239	Calais Hardtop Sedan	N	5,247.00		
68269	Calais Sedan	K	5,247.00		
68367	De Ville Convertible	F	5,639.00		
68357	Coupe de Ville	J	5,419.00		
68339	Hardtop Sedan de Ville	B	5,686.00		
68369	Sedan de Ville	L	5,686.00		
68467	Fleetwood Eldorado Convertible ..	E	6,739.00		
68069	Fleetwood Sixty Special Sedan ..	M	6,479.00		
69723	Fleetwood Seventy-Five Sedan ...	R	9,746.00		
69733	Fleetwood Seventy-Five Limousine	S	9,960.00		

*Includes Federal Excise Tax and Suggested Dealer Preparation and Conditioning Charge. Above basic car prices do not include factory or dealer installed optional equipment or accessories, State or local taxes, Destination Charges (From Detroit, Michigan) or license fees.

1965 Cadillac

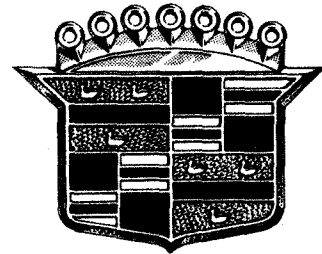

MANUFACTURER'S SUGGESTED RETAIL PRICES • EFFECTIVE JUNE 22, 1965

SERIES	BODY STYLES	MANUFACTURER'S SUGGESTED RETAIL PRICE*	DESTINATION CHARGE TO	MANUFACTURER'S SUGGESTED RETAIL PRICE* PLUS DESTINATION CHARGE
<i>Calais</i>	CALAIS COUPE	\$4,959	\$	\$
	CALAIS HARDTOP SEDAN	\$5,144	\$	\$
	CALAIS SEDAN	\$5,144	\$	\$
<i>De Ville</i>	DE VILLE CONVERTIBLE	\$5,528	\$	\$
	COUPE de VILLE	\$5,312	\$	\$
	HARDTOP SEDAN de VILLE	\$5,554	\$	\$
	SEDAN de VILLE	\$5,554	\$	\$
FLEETWOOD	FLEETWOOD ELDORADO CONVERTIBLE	\$6,604	\$	\$
	FLEETWOOD SIXTY SPECIAL SEDAN	\$6,351	\$	\$
	FLEETWOOD SEVENTY-FIVE SEDAN	\$9,553	\$	\$
	FLEETWOOD SEVENTY-FIVE LIMOUSINE	\$9,762	\$	\$

*Includes Federal Excise Tax And Suggested Dealer Preparation And Conditioning Charge. Does Not Include Factory Or Dealer Installed Optional Equipment Or Accessories, State Or Local Taxes, Destination Charge (From Detroit, Michigan) Or License Fees. All Body Styles May Be Ordered Without Heater-Defroster And/Or Front Seat Belts As A Deletion Option At Reduced Charges.

OPTIONAL EQUIPMENT AND ACCESSORIES WHEN INSTALLED AT CADILLAC FACTORY

	MANUFACTURER'S SUGGESTED RETAIL PRICE**		MANUFACTURER'S SUGGESTED RETAIL PRICE**
AIR CONDITIONER —Fleetwood Seventy-Five Sedan and Limousine (For Other Body Styles See Comfort Control)	\$610.44	PADDED ROOF —Coupe de Ville —Hardtop Sedan de Ville and Sedan de Ville (For Fleetwood Sixty Special Sedan See Fleetwood Brougham Option)	\$121.05 \$136.82
AUTOMATIC LEVEL CONTROL —All except Fleetwood Seventy-Five Sedan and Limousine (Standard on Fleetwood Eldorado Convertible and Fleetwood Sixty Special Sedan)	\$ 78.95	RADIO (AM)	\$161.27
BUCKET SEATS —Including Optional Leather Upholstery and Console —De Ville Convertible —Coupe de Ville and Hardtop Sedan de Ville (Optional at no Charge on Fleetwood Eldorado Convertible)	\$183.99 \$321.92	RADIO (AM-FM)	\$187.53
COMFORT CONTROL (Air Conditioner) —All except Fleetwood Seventy-Five Sedan and Limousine (For Fleetwood Seventy-Five Body Styles See Air Conditioner)	\$484.15	RADIO—Rear Control (AM) —Fleetwood Seventy-Five Sedan and Limousine Only	\$241.62
CONTROLLED DIFFERENTIAL	\$ 52.59	SEAT ADJUSTER—4 Way—Driver's Bucket Seat —De Ville Convertible, Coupe de Ville and Hardtop Sedan de Ville (Standard on Fleetwood Eldorado Convertible)	\$ 52.55
CRUISE CONTROL	\$ 94.62	SEAT ADJUSTER—6 Way—Front —Calais Coupe, Calais Hardtop Sedan and Calais Sedan —De Ville Convertible, Coupe de Ville, Hardtop Sedan de Ville, Sedan de Ville and Fleetwood Sixty Special Sedan (Standard on Fleetwood Eldorado Convertible)	\$110.63 \$ 83.23
DOOR EDGE GUARDS —2 Doors —4 Doors	\$ 3.96 \$ 7.15	SEAT BELTS (2 Rear)	\$ 22.12
DOOR LOCKS—Power —2 Doors —4 Doors (All except Fleetwood Seventy-Five Sedan and Limousine)	\$ 44.77 \$ 68.50	STEERING WHEEL—Tilt and Telescope —All except Fleetwood Seventy-Five Sedan and Limousine	\$ 89.48
FLEETWOOD BROUGHAM OPTION —Fleetwood Sixty Special Sedan Only	\$194.73	TIRES—White Wall (5) —All except Fleetwood Seventy-Five Sedan and Limousine —Fleetwood Seventy-Five Sedan and Limousine (Standard on Fleetwood Eldorado Convertible)	\$ 56.26 \$ 63.41
GLASS—SOFT RAY	\$ 50.59	TRUNK LOCK—Remote Control —All except Fleetwood Seventy-Five Sedan and Limousine	\$ 52.05
HEADLAMP CONTROL—GUIDE-MATIC —All except Fleetwood Seventy-Five Sedan and Limousine —Fleetwood Seventy-Five Sedan and Limousine	\$ 50.02 \$ 44.77	TWILIGHT SENTINEL	\$ 28.43
LEATHER UPHOLSTERY (***)—7 Options—(Bench Type Seat) —Coupe de Ville, Hardtop Sedan de Ville, Sedan de Ville and Fleetwood Sixty Special Sedan	\$137.93	VENT WINDOWS—Power —Available only with Power Windows (Standard on Fleetwood Eldorado Convertible and Fleetwood Sixty Special Sedan)	\$ 71.64
LICENSE FRAME (Each)	\$ 5.74	WINDOWS—Power —Calais Coupe, Calais Hardtop Sedan and Calais Sedan (Standard on All Other Body Styles)	\$115.91

Includes Federal Excise Tax, But Does Not Include Any State Or Local Taxes. Optional Equipment And Accessory Items Shown As "Standard" For Designated Styles Are Included At No Extra Charge In The Manufacturer's Suggested Retail Prices For Such Styles. *Leather Upholstery Option Implies The Use Of Coated Fabric On Certain Areas.

All Prices, Optional Equipment, Accessories And Styles Subject To Change Without Notice.

CADILLAC MOTOR CAR DIVISION, GENERAL MOTORS CORPORATION, DETROIT, MICHIGAN

OPTIONAL EQUIPMENT AND ACCESSORIES

MANUFACTURER'S SUGGESTED RETAIL PRICES

P	Automatic Level Control.....(G-N-K-F-J-B-L)	\$ 80.85
B	Bucket Seats (Includes Console).....(F)	187.85
B	Bucket Seats & Optional Leather (Includes Console).....(J-B)	328.75
K	Comfort Control (Air Conditioner-Heater System)..... (All Except R-S)	484.50
G	Controlled Differential.....(All)	53.70
C	Cruise Control.....(All)	96.60
D	Door Edge Guards — 2 Doors.....(G-F-J-E)	4.08
D	Door Edge Guards — 4 Doors.....(N-K-B-L-M-R-S)	7.30
M	Door Locks — Power — 2 Doors.....(G-F-J-E)	45.75
M	Door Locks — Power — 4 Doors.....(N-K-B-L-M)	70.00
—	Fleetwood Brougham Option.....(M)	198.00
E	Glass — Soft Ray.....(All)	51.70
U	Headlamp Control — Guide-Matic.....(All Except R-S)	51.10
—	Leather Upholstery* (Seven Options).....(J-B-L-M)	140.90
S	License Frame (Each).....(All)	5.85
—	Padded Roof.....(J)	123.65
—	Padded Roof.....(B-L)	139.75
R	Radio (AM).....(All)	184.60
R1	Radio (AM-FM).....(All)	191.40
T	Seat Adjuster—4-Way Driver's Bucket Seat.....(F-J-B)	93.65
Y	Seat Adjuster—6-Way Front.....(G-N-K)	113.05
Y	Seat Adjuster—6-Way Front.....(F-J-B-L-M)	85.00
A	Seat Belts (2 Rear).....(All)	18.30
Q	Steering Wheel—Tilt & Telescope.....(All Except R-S)	91.40
W	Tires—White Wall (Five).....(G-N-K-F-J-B-L-M)	57.45
S	Trunk Lock—Remote Control.....(All Except R-S)	53.15
J	Twilight Sentinel.....(All)	26.00
N	Vent Windows—Power**.....(G-N-K-F-J-B-L-R-S)	73.20
X	Windows—Power.....(G-N-K)	118.45

SEVENTY-FIVE SEDAN AND LIMOUSINE:

K	Air Conditioner.....(R-S)	623.70
U	Headlamp Control—Guide-Matic.....(R-S)	45.75
—	Landau Roof.....(R-S)	1935.00
R2	Radio—Rear Control (AM).....(R-S)	248.00
W	Tires—White Wall (Five).....(R-S)	64.75

*Leather upholstery option implies the use of coated fabric on certain areas.
 **When ordered with Power Windows.
 Above prices include Federal Excise Tax, but do not include any state or local taxes.

Prices do not include dealer installation charge, state or local taxes.

Compass.....(All)	\$ 5.00
Eldorado Horn.....(All, Except E)	24.50
Floor Mat—Front One-Piece Full.....(All)	10.95
Floor Mats—Front RH and LH (Pair).....(All)	6.95
Floor Mat—Rear One-Piece Full.....(All, Except R-S)	7.95
Floor Mats—Rear RH and LH (Pair).....(All, Except R-S)	5.95
Foot Selector Control—AM Radio.....(All)	4.75
Front Center Seat Belt (Each).....(All)	9.00
Front or Rear Cushion Cover (Each).....(All, Except Bucket Seats & R-S)	15.50
Litter Basket.....(All)	2.75
Luggage Compartment Mat.....(All, Except R-S)	5.95
Rear Seat Belt (Each).....(All)	9.00
Rear Window Defogger.....(G-N-K-J-B-L-M)	29.75
Spare Tire Cover.....(All, Except E-M)	4.95

X	WINDOWS, Power	X	WINDOWS, Power
W	TIRES, White Wall	W	TIRES, White Wall
R	RADIO, AM	RI	RADIO, AM-FM
E	GLASS, Soft Ray	E	GLASS, Soft Ray
Y	SEAT ADJUSTER, 6-Way Front	Y	SEAT ADJUSTER, 6-Way Front
or		or	
T	SEAT ADJUSTER, 4-Way Driver's Bucket	T	SEAT ADJUSTER, 4-Way Driver's Bucket
D	DOOR EDGE GUARDS	D	DOOR EDGE GUARDS
K	COMFORT CONTROL (air conditioner-heater system)	K	COMFORT CONTROL (air conditioner-heater system)

X	WINDOWS, Power	X	WINDOWS, Power
W	TIRES, White Wall	W	TIRES, White Wall
R	RADIO, AM	RI	RADIO, AM-FM
E	GLASS, Soft Ray	E	GLASS, Soft Ray
Y	SEAT ADJUSTER, 6-Way Front	Y	SEAT ADJUSTER, 6-Way Front
or		or	
T	SEAT ADJUSTER, 4-Way Driver's Bucket	T	SEAT ADJUSTER, 4-Way Driver's Bucket
D	DOOR EDGE GUARDS	D	DOOR EDGE GUARDS

U	HEADLAMP CONTROL, Guide-Matic
Q	STEERING WHEEL, TILT & TELESCOPE
M	DOOR LOCKS, Power
J	TWILIGHT SENTINEL
S	TRUNK LOCK, Remote Control
G	CONTROLLED DIFFERENTIAL
C	CRUISE CONTROL
N	VENT WINDOWS, Power
P	AUTOMATIC LEVEL CONTROL

OTHER CODES

6	LICENSE FRAME, One	OPTIONAL GEAR RATIO	
or			
9	LICENSE FRAMES, Two	1	3.21
F	FILLER PLATE	7	3.77—Fleetwood 75 Only
A	SEAT BELTS—(2 Rear)	0	Delete 2 Front Seat Belts
R2	RADIO, Rear Control (AM)—Fleetwood 75 Only	H	Delete Heater-Defroster

ACCESSORIES & OPTIONS

<u>CODE</u>	<u>DESCRIPTION</u>	<u>PRICE</u>
P	Automatic Level Control	\$ 78.95
B	Bucket Seats (*) (Inc. Console)	183.99
K	Comfort Control (A/C)	484.15
G	Controlled Differential	52.59
C	Cruise Control	94.62
D	Door Edge Guards-2 Doors	3.96
D	Door Edge Guards-4 Doors	7.15
M	Door Locks-Power-2 Doors	44.77
M	Door Locks-Power-4 Doors	68.50
	Fleetwood Brougham Option	194.73
E	Glass-Soft Ray	50.59
U	Headlamp Contr.-Guide-Matic	50.02
	Leather Upholstery (Seven Opt.)	137.93
8	License Frame (Each)	2.74
	Padded Roof	121.05
	Padded Roof	136.82
R	Radio (AM)	161.27
R1	Radio (AM-FM)	187.53
T	Seat Adj.-4 Way-Driver's Bucket Seat	52.55
Y	Seat Adj.-6 Way-Front	110.63
Y	Seat Adj.-6 Way-Front	83.23
A	Seat Belts/2 Rear	22.12
Q	Steering Wheel-Tilt & Telescope	89.48
W	Tires-White Wall (Five)	56.26
S	Trunk Lock-Remote Control	52.05
J	Twilight Sentinel	28.43
N	Vent Windows-Power (**)	71.64
X	Windows-Power	115.91
SEVENTY-FIVE SEDAN AND LIMOUSINE:		
K	Air Conditioner	610.44
U	Headlamp Control-Guide-Matic	44.77
R2	Radio-Rear Control (AM)	241.62
W	Tires-White Wall (Five)	63.41
(*) When ordered with Leather Upholstery		
(**) When ordered with Power Windows		

1965 CADILLAC PRICES

<u>BODY TYPE NUMBER</u>	<u>BODY TYPE CODE</u>	<u>BODY TYPE</u>	<u>LIST PRICE</u>
68257	G	Calais Coupe	\$4869.00
68239	N	Calais Hardtop Sedan	\$5054.00
68269	K	Calais Sedan	\$5054.00
68367	F	DeVille Convertible	\$5438.00
68357	J	Coupe DeVille	\$5222.00
68339	B	Hardtop Sedan DeVille	\$5464.00
68369	L	Sedan DeVille	\$5464.00
68467	E	Fleetwood Eldorado Conv.	\$6514.00
68069	M	Fleetwood 60S Sedan	\$6236.00
68169		Fleetwood Brougham	
69723	R	Fleetwood Seventy-Five Sed.	\$9403.00
69733	S	Fleetwood Seventy-Five Limo.	\$9612.00

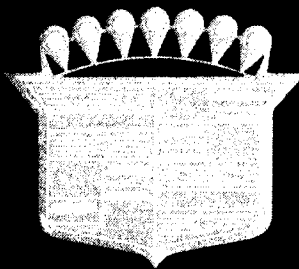

Nineteen Sixty-Five

CADILLAC

Owner's Manual

Your luxurious new 1965 Cadillac will provide you with many miles of motoring pleasure in the months to come. The information in this manual will help you derive the utmost satisfaction and performance from your new Cadillac.

We suggest you review the operating instructions carefully so that you can enjoy the many exclusive features engineered into this fine motor car. A complete understanding of the proper operating procedures will add further to your enjoyment of your 1965 Cadillac.

The operating instructions that pertain exclusively to the Fleetwood Seventy-Five Sedan and Limousine are explained in Section 3, beginning on page 28. The general information and service recommendations found in other sections of this manual apply to all 1965 model Cadillac cars.

This information was prepared to assist you. Follow the instructions carefully, and if a question should ever occur that is not answered here, do not hesitate to write us. We will be happy to hear from you at any time.

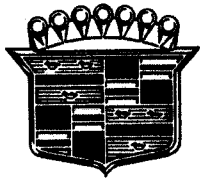

**SERVICE DEPARTMENT
CADILLAC MOTOR CAR DIVISION
GENERAL MOTORS CORPORATION
DETROIT, MICHIGAN 48232**



OPERATING YOUR CADILLAC

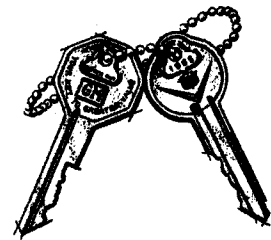

Your new Cadillac is ready for all normal driving just as you receive it from your dealer. Precision manufacturing techniques have prepared it for the road and a formal break-in period is not required. From the very start, drive your new Cadillac in a normal manner at varying speeds, as required by different traffic and road situations.

SECTION

1

Keys

Two separate keys are provided for your convenience. The key with the octagonal head operates the ignition and door locks. The rounded key is used in the luggage compartment and glove box door locks, and in the center console on models with bucket seats, to protect the contents of these compartments when it is necessary to leave the ignition key with your car. Remove the "knock-out" plug with key number from the key head and keep it, or a record of the number, to facilitate replacement or duplication of your keys.

Ignition switch

The ignition switch is located in the center of the instrument panel to the left of the radio. The key slot is illuminated when instrument panel lights are on. The key can be turned to any one of three positions, but can be inserted or withdrawn only in the straight-up, "OFF" position. First position "right" completes the ignition circuit and activates all instruments and accessories. Full "right" position cranks the engine. The "left" position is for operation of accessories with ignition off. For your own protection and to cooperate with civil authorities, remove the key and lock the car when leaving it unattended.

Instructions for starting the engine

The starter operates when the ignition key is turned to the full "right" position, *provided* the transmission selector lever is in either "Neutral" or "Park". For safety, the starter is inoperative in all driving positions. When the engine is cold, press the accelerator pedal slowly to the toeboard once, then remove your foot, and turn the key to the full "right" position. **DO NOT** hold the key in full "right" position longer than 15 seconds at one time. If the car has been standing over 48 hours, it is helpful to pump the accelerator three times before starting.

Normal restarting

If the engine is warm from previous running (within the last two to four hours), hold the accelerator part way down while cranking.

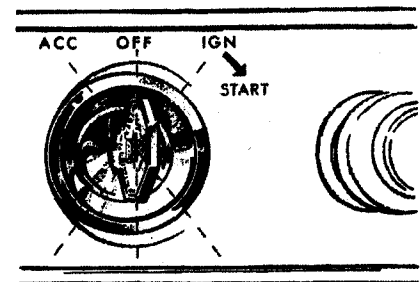

Extreme cold weather starting

The starting procedure for extreme cold weather is basically the same as for normal conditions. Should the engine start, run a few seconds and then stall, repeat the normal starting procedure. If the engine does not restart within five seconds of cranking, push the accelerator to the floor and hold it (**DO NOT PUMP**) while continuing to crank until engine starts. Do not crank engine longer than 15 seconds at a time. Proper engine oil viscosity is very important for easy cold weather starting. See page 40.

Flooded engine

Hold accelerator pedal all the way down and crank until engine starts (not over 15 seconds at a time).

INSTRUMENTS

NOTE: Fuel and temperature gauge needles do not necessarily return to the left when ignition is turned "OFF", but may stop at any point on the gauge.

Fuel gauge

The fuel gauge is located on the lower right side of the instrument cluster. It registers only when the ignition key is turned to the right.

Temperature indicator

The engine temperature gauge is located on the lower left side of the instrument cluster. Normally, the gauge pointer will move gradually from the extreme left to a center position.

Do not be alarmed if the pointer registers above the center range in heavy traffic or on long drives during warm weather. The pressure-controlled overflow will normally prevent coolant losses up to 259°F. If the pointer reaches "H" or if the coolant boils, indicated by a buzzing sound from the radiator cap, stop the car immediately and have the condition causing the overheating corrected. CAUTION: Before removing radiator cap, see page 41.

Oil pressure indicator light

If oil pressure is low, a red indicator light labeled "OIL", located on the right side of the instrument cluster will glow. Under normal conditions this light will glow when

the ignition is turned on, but will go off when the engine is running. If it does not go off, the car should not be operated until the cause of the low oil pressure has been corrected by an Authorized Cadillac Dealer.

Generator indicator light

A red indicator light for the charging circuit is located on the left side of the instrument cluster above the temperature gauge. The light, labeled "GEN", glows whenever the generator is *not* charging. In normal operation, it will light when the ignition is turned on and will go out when the engine starts. If it glows while the engine is running, have your car checked by an Authorized Cadillac Dealer.

Speedometer

The speedometer indicates car speed. The odometer portion which indicates distance traveled, is divided into two

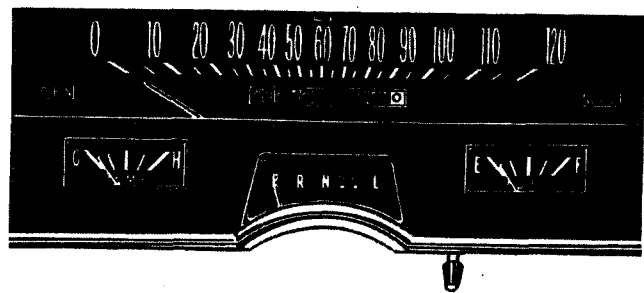

sections—the left half records accumulated mileage and the right half indicates trip mileage. A reset knob for the trip odometer is located below the instrument cluster to the right of the steering column. To reset trip mileage, push in on the reset knob and turn it clockwise until all nines appear. Repeat this operation until all nines reappear, then reverse the knob until all zeros appear.

TRANSMISSION

Your 1965 Cadillac is equipped with a Turbo Hydramatic transmission. The transmission shift indicator has six positions marked park "P", reverse "R", neutral "N", drive "DRIVE" (left and right positions), and low "L".

An arrangement of steps in the steering column restricts a straight line movement of the shift lever. It is necessary to lift up on the lever when shifting into and out of park "P", when shifting from the left hand "DRIVE" position to the right hand "DRIVE" position, and when shifting from "DRIVE" to low "L".

"DRIVE" range

In drive range with the indicator in the left hand "DRIVE" position, three forward speeds are available; the right hand "DRIVE" position provides two forward speeds. The left hand "DRIVE" position is used for all normal driving. This permits the transmission to operate through its complete range of gear ratios and select the proper

gear ratio for road and load conditions.

HILLY TERRAIN—use the right-hand "DRIVE" position. In this position, only first and second speeds are available, improving acceleration and deceleration. The right-hand "DRIVE" position also reduces shifting in traffic and on hills, provides more control on slippery pavement, and decreases brake usage when descending medium grades. It may be selected at any car speed.

PROLONGED IDLING IN HEAVY TRAFFIC—place shift lever in neutral "N" when engine must be idled for long periods in heavy traffic during hot weather.

PASSING—for passing at moderate speeds—between 30-45 miles per hour—depressing the accelerator pedal only part way will usually provide sufficient acceleration. This automatically downshifts the transmission to a lower gear for more power. When additional acceleration is needed for safety in passing at higher speeds, press the accelerator all the way down.

"L" Low range

"L" Low range provides engine braking assist. It should always be used when going up or down very steep grades and where traffic signs call for first or second gear.

A shift from either "DRIVE" position to low "L" can be made while traveling at moderate speeds. This shift is not recommended when the pavement is slippery or when in loose gravel, as it may induce a skid.

NOTE: Should the wheels slide when braking on ice, the transmission may shift to a lower gear. If this occurs, move the shift lever to neutral "N" until control is recovered. Use of intermittent brake pressure when on ice will result in better car control.

"R" reverse

To back up your car, first bring it to a *complete* stop, then move shift lever to the reverse "R" position. The shift lever can be moved to reverse "R" from neutral "N" or any "DRIVE" position without lifting up on the lever. However, it is necessary to lift up on the lever when shifting to reverse "R" from park "P" position.

"P" park

Place shift lever in the park "P" position to lock rear wheels when parked. When parking on hills or steep inclines, apply parking brake and turn front wheels toward curb. It is necessary to raise the shift lever when moving it from any other position to park "P" and also when moving it from the park "P" position. NEVER move the lever to park "P" with the car in motion.

Emergency starting procedure

The engine cannot be started by pushing the car. If the trouble appears to be a discharged battery, a booster battery and jumper cables should be used. If this fails to

start the engine, the car should be towed to an Authorized Cadillac Dealer.

Towing

If the transmission, drive line, and rear axle are in proper operating condition, the 1965 Cadillac can be safely towed at speeds up to 45 MPH for distances up to 50 miles. Always tow car with transmission shift lever in "Neutral" position.

For higher speeds or longer distances, the propeller shaft must be disconnected or the rear wheels raised off the ground. If towing requires raising the rear of the car, the wheels should be raised just slightly off the ground and the steering wheel should be tied down with front wheels in straight ahead position.

CONTROLLED DIFFERENTIAL

A Controlled Differential (optional at extra cost) is available on all models. The Controlled Differential makes driving safer and more economical by providing additional traction in snow, ice, mud, sand and gravel, particularly when one rear wheel is on a surface providing poor traction.

During normal driving and cornering, the controlled unit functions as a standard differential. When one wheel encounters a slippery surface, however, the Controlled

Differential allows the wheel with the greater traction to drive the car.

CAUTION: On cars equipped with a Controlled Differential, do not jack one rear wheel off the ground with engine running.

POWER BRAKES

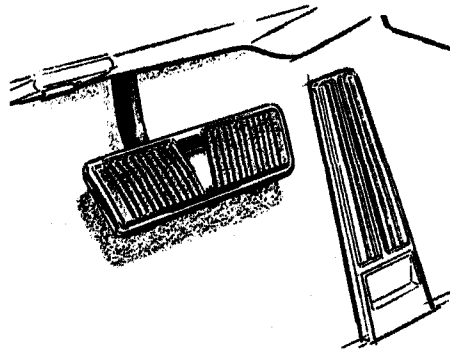

Your 1965 Cadillac is equipped with power brakes incorporating a dual reservoir master cylinder. With this type cylinder, the front and rear brakes have separate hydraulic systems. The rear brakes are not affected in the event of fluid leaks from the front hydraulic system. Likewise, the front brakes are not affected by loss of fluid from the rear hydraulic system. Loss of fluid is signaled by excessive brake pedal travel. If this condition is en-

countered, immediate inspection should be made by your Authorized Cadillac Dealer.

The power brake unit has a self-contained reserve tank that permits several applications of the brakes with power assist after the engine has stopped. After this reserve is used up, or should the power system become inoperative, the brakes can be applied in the conventional manner; however, more effort is required due to the loss of power assist. The width of the brake pedal will allow comfortable use of two-foot application. In the event of power assist being lost, the use of both feet on the pedal will result in a normal braking feel.

Under normal driving conditions your Cadillac does not require manual brake adjustments to compensate for lining wear. All wheels are equipped with automatic brake adjusters. The brakes are automatically adjusted, if adjustment is required, each time they are applied when the car is moving rearward. To assure best operation of the brake system, have brakes inspected periodically by your Authorized Cadillac Dealer.

Parking brake

To apply the parking brake, step on the parking brake pedal suspended from the underside of the instrument panel to the left of the power brake pedal. It will lock

into place automatically when the transmission is in "Park" or "Neutral" with engine running, or in any position with engine not running.

The parking brake will release automatically when the transmission selector lever is moved to any drive range with the engine running. A definite noise should be heard when the pedal releases. Do not drive the car unless the parking brake is completely released. Should it be necessary to release the brake manually, pull on the hand release lever located on the upper right side of the parking brake assembly. Since the parking brake will not lock into place when the transmission selector is in "Drive",

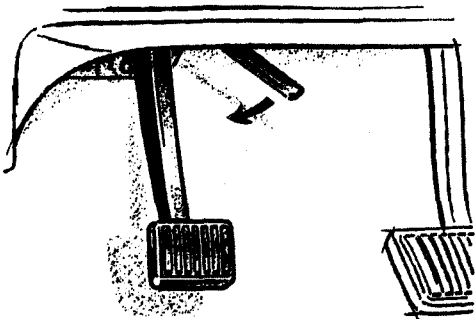

"Low" or "Reverse" ranges with the engine running, it may be used as a fully controllable brake pedal, providing rear wheel braking only, under emergency or special conditions.

As a safety precaution when parking on hills, it is advisable to turn the wheels toward the curb, lock the rear wheels by placing the transmission selector in "Park" position, and place the parking brake in its fully depressed position. When pedal travel of the parking brake exceeds five inches, it should be adjusted by your Authorized Cadillac Dealer.

POWER STEERING

Steering, turning, and parking are made almost effortless with Cadillac power steering. Your car provides easy and responsive steering, with power assist available as required by road conditions.

Your Cadillac may be steered manually with no power assist when the engine is not running. If your power steering becomes inoperative for any reason, the car may be steered manually, but with increased effort.

CONTROLS

Your new Cadillac has accessible controls and easy to read dials and instruments that are designed for your safety and convenience. Only a few minutes are required to gain an understanding of the proper use of these in-

struments and controls. Refer to the illustration on page 10 (or page 30) to become acquainted with your 1965 Cadillac instrument panel.

Windshield wipers and washers

The three-speed windshield wipers are controlled by a lever located on the instrument panel to the left of the steering column. To operate the wipers, move the lever to the first triangular mark "LOW", the second triangular mark "MEDIUM", or "HIGH" position. Do not try to move the blades by hand or attempt to run the wipers if the blades are frozen to the glass. Avoid operating the wipers on a dry windshield.

Windshield washers are provided for cleaning a windshield soiled with dust, road spray or dirt. Pressing the washer button, located to the left of the wiper control lever, actuates the wipers to operate at low speed and sprays solution on the windshield. When washing action is completed and the windshield is dry, move the wiper lever to the "OFF" position.

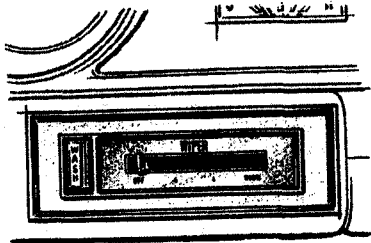

Headlight control

The control knob for the headlights, parking lights, instrument panel lights, and courtesy lights is located in the instrument cluster to the left of the speedometer. HEADLIGHTS are operated by pulling the switch control knob all the way out. PARKING LIGHTS come on as the same knob is pulled halfway out. INSTRUMENT PANEL LIGHTS are on in both positions. Instrument panel lights can be increased or decreased in intensity, or turned off, by rotating the control knob. Rotating it completely counterclockwise turns on courtesy lights.

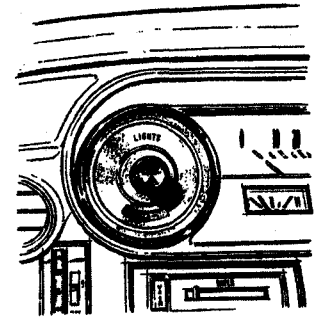

Headlight dimmer switch

The headlight dimmer switch permits you to select the correct headlight beam for different types of driving. All four lights are on when you use the high beam for highway driving . . . only the upper lights (outer lights on Seventy-Five's) are on for low beam city driving. Select desired beam by depressing the switch located on the floor just below the parking brake pedal.

INSTRUMENT PANEL AND CONTROLS

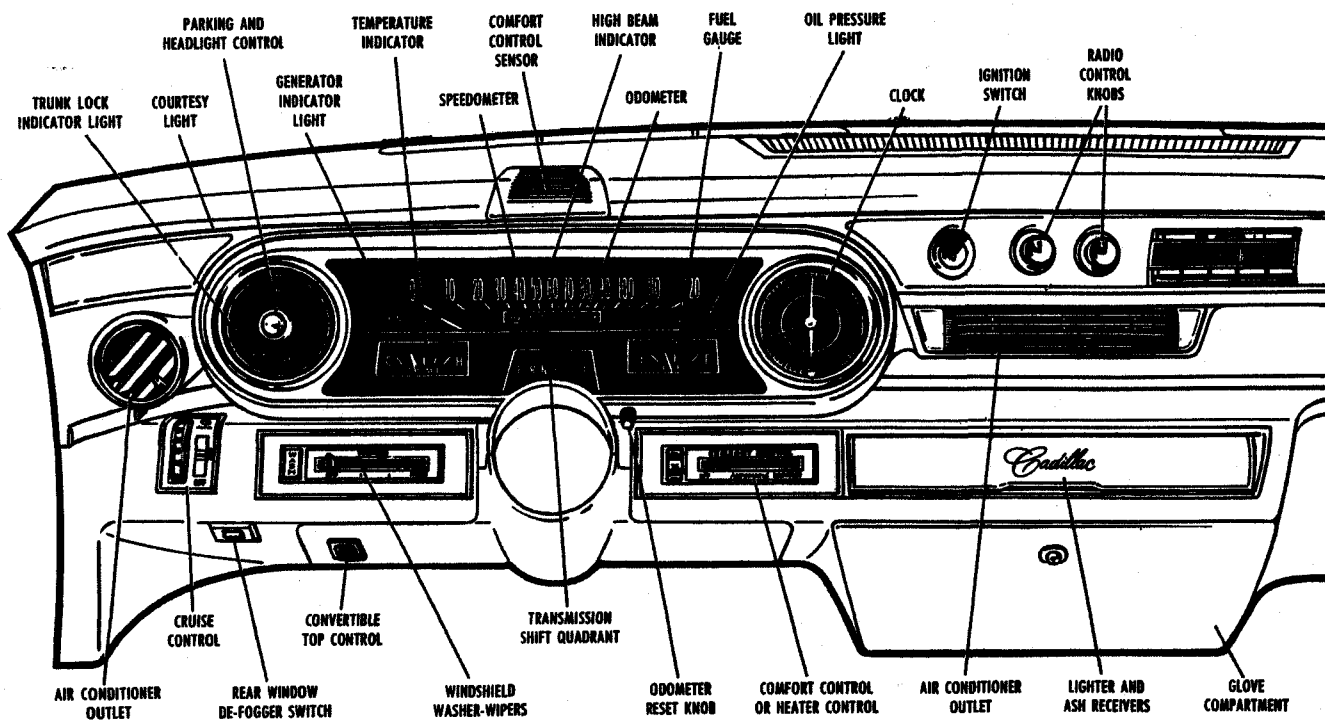

High beam indicator

When the headlights are on high beam, an indicator light above the 60 MPH mark in the instrument cluster glows red. Never leave the high beam on when approaching oncoming traffic.

Courtesy lights

Your Cadillac is equipped with courtesy lights that illuminate the interior of the car when any door is opened. When all doors are closed, full counterclockwise position of the headlight control knob turns on courtesy lights. A manual switch is centrally located on the back of the front seat divider on some sedan styles, and on the rear quarter trim panel above the left armrest on some coupe styles, for control of rear courtesy lights. On convertible styles, the manual switch is integral with the courtesy light on the front of the left rear armrest.

Electric clock

A fully automatic electric clock is located in the instrument cluster to the right of the speedometer. To reset, pull out the reset knob firmly and rotate in the direction you want to move the minute hand, until the hands register the correct time. Resetting the clock 5 or more minutes in either direction will automatically regulate the clock to run approximately 20 seconds faster or slower per day, depending on which way the reset knob is rotated. If

more than a 20-second adjustment is desired, you can reset it after 12 hours have elapsed and thereby adjust it to run an additional 20 seconds faster or slower.

To assure accurate time-keeping, your clock should be removed for cleaning and oiling every two years by your Cadillac Dealer, who will be pleased to send it to an authorized clock repair station for necessary maintenance at reasonable cost.

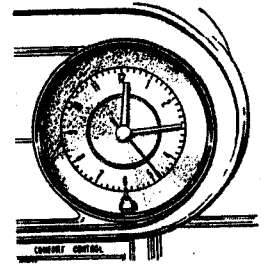

Ash receivers and lighters

There is an illuminated dual ash receiver and a lighter located in the center of the instrument panel for the convenience of both passenger and driver. The ash receiver door can be opened by pushing on the cover tab and can be closed by pulling rearward on the cover tab.

Rear combination ash receivers and lighters are provided on all models except the Calais Coupe, which is equipped with ash receivers only.

Back-up lights

For safety and convenience, your Cadillac is equipped with dual back-up lights that go on automatically when the transmission selector lever is in the "Reverse" position with the ignition switch on.

Turn signal

The turn signal lever is mounted on the left side of the steering column. The turn signal lever should be moved to the "up" position to signal for a right turn and to the "down" position for a left turn. This activates flashing signals on the right or left, both front and rear of the car, to inform oncoming and following drivers of the direction you intend to turn. Corresponding right and left signal indicator lights are located facing rearward on top of each front fender crown molding. A steady beam from either indicator light means failure of a front or rear signal bulb. For safety, and to comply with the law, have burned out bulbs replaced at once.

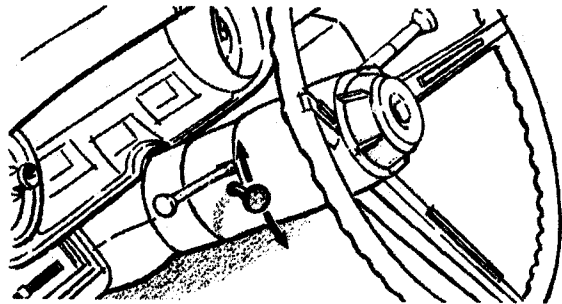

Cornering lights

Your Cadillac is equipped with cornering lights that operate in conjunction with the turn signals. When the turn signal is operating in either direction with headlights or parking lights on, the corresponding cornering light emits a steady sideward beam to provide additional illumination when turning corners.

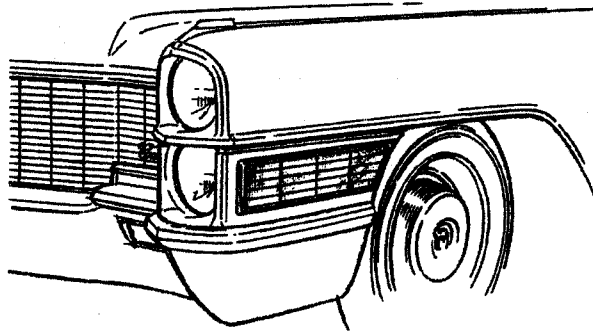

MIRRORS

Glare-proof inside rear-view mirror

The Cadillac glare-proof inside rear-view mirror is moved from clear daylight visibility to non-glare visibility at night by rotating the small tab at the bottom of the mirror. The mirror can be moved to accommodate the driver's height and seat position by moving the pivoted ball stud up or down.

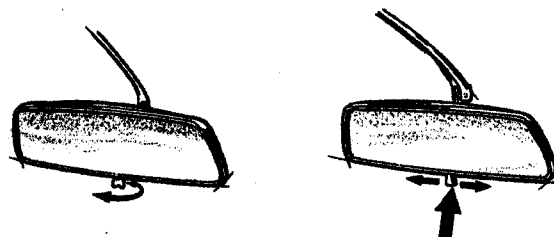

Fleetwood inside rear-view mirror

The Fleetwood Sixty Special and Eldorado Convertible 3-Way inside rear-view mirror has an adjustment for three differing types of driving. For daylight driving the lever at the bottom of the mirror should be in the left hand position. For normal night driving the lever should be positioned at the center of the bottom of the mirror. Move the lever to the right to counteract intense glare.

Remote-control outside mirror

Your Cadillac is equipped with a remote-control outside rear-view mirror. Movement of the handle, inside the car, allows you to adjust the mirror to suit your requirements. Additional rotational adjustment is possible by rotating the mirror head in its support.

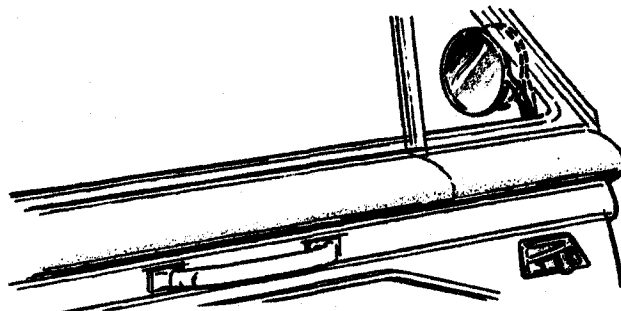

VENTILATION AND HEATING

Ventilation

On cars not equipped with Comfort Control, outside air is drawn into the passenger compartment through the grille located in the cowl directly below, and in front of, the windshield. This location, minimizes intake of exhaust fumes from other cars. Ventilation controls are located in a panel above the glove box. Moving the control levers individually, right or left, away from the "OFF" position, opens air doors and admits ventilating air. The levers can be moved gradually to admit as much air as you desire.

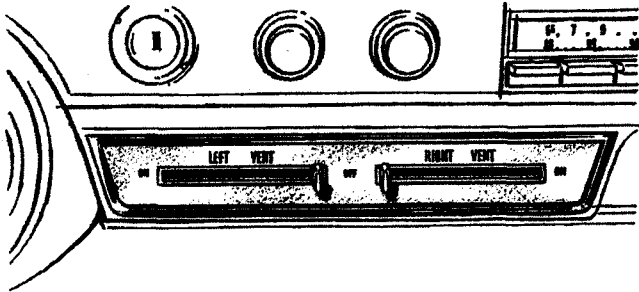

Heating

The Cadillac Heating System delivers heated air through a unit located on the right-hand side of the cowl. Outside air is delivered through the heating system to the front passenger compartment by means of grilles and openings in front of the dash panel. Heated air is delivered to the rear passenger compartment through ducts that extend under the front seat. Part or all of the heated air can be delivered to the windshield for removing fog or ice.

Heater control operation

The heater controls are located in the instrument panel to the right of the steering column (left, on Fleetwood Seventy-Five). The controls consist of a switch to control fan speed and two horizontal sliding levers to control the defroster and heater. The controls are illuminated when instrument panel lights are on.

The system can be operated with the fan switch "OFF", or with the fan running at any one of three speeds.

The lower lever controls the temperature. To increase the temperature, move the lever to the right; to decrease the temperature, move it to the left. The upper lever turns the heater on and off, and controls the quantity of defrosting air delivered to the windshield. Moving the upper lever to "HEAT" turns the heater on. If

air is desired on the windshield, move the lever to the "DE-FOG" position, and move the lower lever to the desired temperature position. For removing ice, move both levers to the extreme right, "DE-ICE" position, and move the fan switch to "HIGH".

Heater control during warm-up

For maximum heat and quickest warm-up in cold weather, place the upper lever at "HEAT", move the lower lever all the way to the right, and set the fan switch on "HIGH". If it is necessary to remove some fog during this period, move upper lever to "DE-FOG" to direct air to the windshield. Any snow covering the cowl air intake grille should be removed to facilitate defogging. It will be most

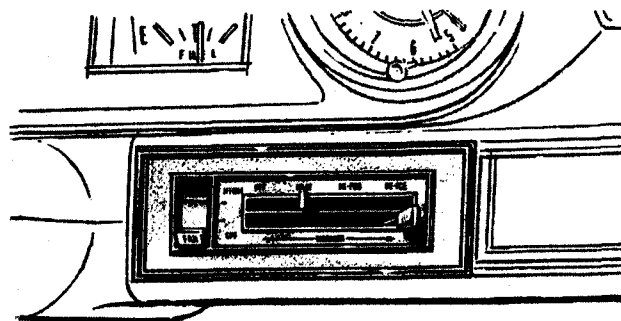

comfortable in extremely cold weather to place the upper lever in the "DE-FOG" position.



OTHER FEATURES

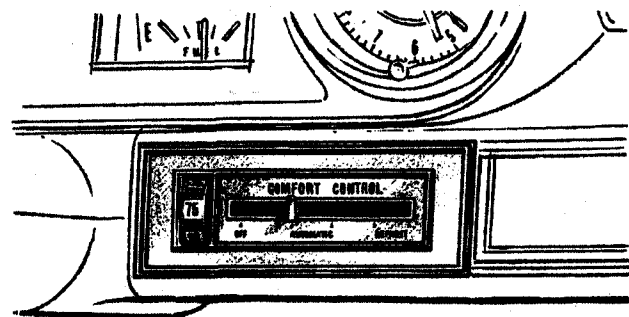

COMFORT CONTROL AIR CONDITIONER

The Cadillac Comfort Control Air Conditioner system (optional at extra cost) automatically controls the Air Conditioner-Heater system to provide the interior temperature selected by the driver on the control panel temperature dial.

Comfort Control is a completely automatic system that requires no change of setting due to outside weather conditions.

In warm weather, cooled, dehumidified air is discharged from three adjustable outlets—one at each end and one in the center of the instrument panel. In cool weather, warm air (as high as 90°F.) may be emitted from the three outlets. Each outlet can be rotated to direct air throughout the car. The end outlets can be closed off by turning the knob beneath each outlet. The center outlet can be closed off by rotating the thumb wheel.

In cold weather, heated air enters the passenger compartment through the heat distributor to the front and rear floor areas.

SECTION

2

CONTROLS

The control panel for "Comfort Control" is located just below the instrument cluster to the right of the steering column.

Normal operation

1. Set the temperature dial on the control panel to the interior temperature desired.
2. The horizontal sliding lever should be positioned at the white triangle above the word "AUTOMATIC". This turns the system on and provides 100% outside air at all times.

NOTE: After initial settings are made, it is not necessary to turn the system "OFF". The air conditioner-heater system will operate automatically whenever the car is started; it will start almost immediately in warm weather, but heater operation in cold weather will be delayed until heat is available from the engine coolant.

Unusual operation

Three additional settings of the control lever are provided for use in those few instances when extreme weather conditions call for extra volumes of heated or cooled air or for air to be directed to the windshield.

The setting marked by a red triangle above the word

"AUTOMATIC" causes the system to operate similar to the white triangle setting but at maximum blower speed, resulting in quicker cool-down in summer and warm-up in winter, and allows the air conditioner to operate on 80% recirculated air for maximum cooling efficiency.

NOTE: To achieve quicker cool-down when the car has been parked in the hot sun, it is recommended that the end outlets be positioned so they face outboard and upward on a 45° angle and the center outlet be positioned upward on a 20° angle. Also the rear windows should be lowered approximately two inches for a few minutes to exhaust the hot air.

The first "DEFROST" position should be used when the windshield is fogged over. This will direct a portion of the discharge air to the windshield and cause the blower to operate at a medium speed.

The second "DEFROST" position provides maximum

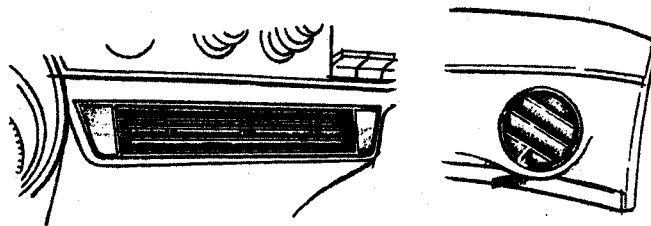

heated air at HIGH blower speed, all of which is delivered to the windshield for melting snow and ice.

REAR WINDOW DE-FOGGER

The Cadillac Rear Window De-Fogger (available from your Authorized Cadillac Dealer at extra cost) aids in keeping the rear window clear. This unit is available on all models except convertibles and Fleetwood Seventy-Five Sedans and Limousines. It is controlled by a switch on the lower side of the instrument panel to the left of the steering column. For "HIGH" fan speed, move switch to the right. For "LOW" speed, move it to the left. The De-Fogger is "OFF" when the switch is in center position.

In operation, the De-Fogger directs air against the rear window from an outlet in the rear compartment package shelf, thus keeping the rear window free of mist and fog.

TILT AND TELESCOPING STEERING WHEEL

The Tilt and Telescoping steering wheel (optional on some models at extra cost) can be tilted to any one of six different positions, and can be adjusted in and out within a 3-inch range to the most comfortable distance between you and the wheel. This permits individual selection of the most natural and comfortable position for all driving conditions. Also, on long trips, the steering wheel position

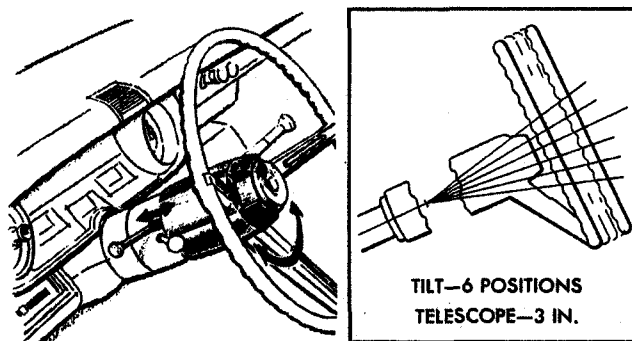

can be changed to minimize tension and fatigue. The adjustments are simple, and independent of each other.

The *tilt* mechanism is operated by lifting up the small lever on the left side of the steering column, just below the turn signal lever, moving the steering wheel to one of six angles, and releasing the lever. Telescoping of the wheel *distance* is obtained by rotating the locking ring in the center of the steering wheel counterclockwise, to unlock the mechanism, sliding the wheel into the desired position and turning the locking ring clockwise to make the adjustment secure.

Both the tilt and telescoping mechanisms can be changed while driving.

These features also permit maximum ease in entering and leaving the car. The wheel is spring-loaded, so that lifting the tilt lever automatically raises the wheel to its uppermost position. Additional clearance can be obtained by unlocking the ring and moving the wheel all the way into the column.

The Tilt and Telescoping steering wheel can be adjusted in conjunction with the seat to provide the maximum in driving comfort.

CRUISE CONTROL

Cadillac Cruise Control (optional at extra cost) is a speed reminder and automatic speed regulating device, controlled by a speed setting dial and a three-position slide switch marked "OFF", "ON", and "AUTO". In the "OFF" position, the unit has no effect on driving.

To use as a **SPEED REMINDER**, rotate the dial until desired speed setting, as indicated by the numerals on the dial rim, is lined up with the center of the slide switch. Then move slide switch forward to the "ON" position. Your Cruise Control indicates that the selected speed has been reached when back pressure is felt on the accelerator pedal.

Cruise Control does not interfere with normal accelerator pedal movement up to the selected speed reminder setting. To obtain further acceleration above that speed, press the accelerator pedal against the warning back pressure.

For **AUTOMATIC SPEED CONTROL**, move slide switch forward momentarily to the "AUTO" position; this will cause the red indicator light on top of the control panel to glow, indicating the Cruise Control is ready for automatic operation. Then rotate dial to desired speed setting. Accelerate until the

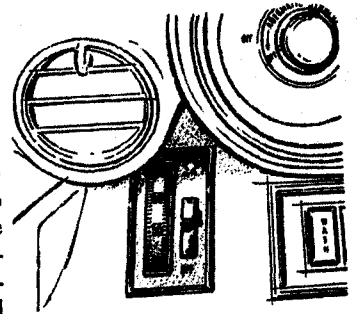

selected speed is reached and back pressure is felt on the accelerator pedal. The car will now automatically maintain the selected speed with the driver's foot off the accelerator pedal. Selected speed will be maintained, within the limits of engine performance, even when driving uphill or down.

When the unit is in automatic control, car speed can be changed by slowly rotating the dial forward to increase speed, or backward to decrease speed.

CAUTION: When changing speed during automatic control, the dial acts as a hand throttle. Always rotate dial slowly to prevent sudden acceleration.

In automatic control, car speed can be increased also by pressing the accelerator pedal against the warning back pressure.

Automatic control is disengaged when the brake pedal is depressed. To re-engage, accelerate until back pressure is again felt. The unit will again engage automatically. It is not necessary to move the slide switch to the "AUTO" position to re-engage automatic control.

The "OFF" position is provided so the slide switch may be moved rearward to disengage automatic control completely without the necessity of depressing the brake pedal. The unit is also completely disengaged whenever the ignition switch is turned off.

With the unit "OFF", no back pressure will be felt at any speed and the indicator light will not glow. When automatic control is disengaged in this manner, it is necessary to move the slide switch forward momentarily to the "AUTO" position to re-engage automatic control.

GUIDE-MATIC POWER HEADLIGHT CONTROL

The Guide-Matic Power Headlight Control (optional at extra cost) automatically switches your car's headlights from high to low beam when another vehicle approaches from the opposite direction and returns them to high beam again when conditions require it.

An override switch, integral with the headlight dimmer switch, permits the driver to hold the headlights on high beam. A sensitivity control ring located directly behind

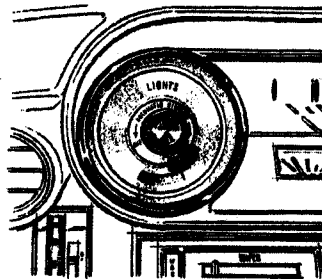

the control ring clockwise toward the word "FAR" causes the lights to dim sooner; rotating it counterclockwise delays the dimming action.

For manual operation of headlight dimming, rotate the Guide-Matic control ring counterclockwise to the "OFF" position.

NOTE: On Fleetwood Seventy-Five cars, the sensitivity control is a knob located on the rear of the phototube unit, which is mounted on the top center of the instrument panel.

TWILIGHT SENTINEL

Cadillac Twilight Sentinel (optional at extra cost) automatically turns on your car's headlights, instrument panel lights and tail lights as darkness approaches, when the

ignition switch is "ON". The unit also turns the lights off as daylight approaches.

The Twilight Sentinel control lever is located behind the headlight control knob escutcheon (on cars equipped with Guide-Matic Power Headlight Control, the control lever is located behind the sensitivity control ring.)

For automatic operation, rotate the control lever clockwise to the "ON" position and push the headlight control knob all the way in. Your car's lights will automatically turn "ON" as darkness approaches and "OFF" as daylight approaches.

A variable time delay feature permits the headlights, instrument panel lights, and tail lights to remain "ON" after the ignition switch is turned "OFF" for added convenience and safety in darkened areas. Additional side lighting can be obtained by activating a cornering light with the turn signal lever. For TIME DELAY ACTION, rotate the control lever clockwise between "ON" and "MAX" to the position that provides the desired time delay. Maximum time delay is approximately 90 seconds.

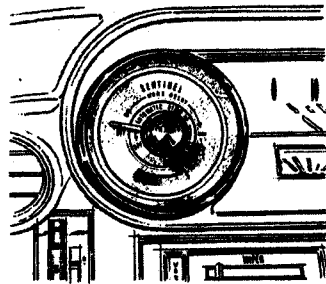

For manual operation of the headlights, rotate the control lever counterclockwise to the "OFF" position. This permits conventional operation of lights with the headlight control knob.

RADIOS

The Cadillac AM and AM-FM model radios (optional at extra cost) are both fully transistorized. The radio is located in the center of the instrument panel. Two control knobs are located to the left of the radio dial. Five push buttons are provided below the dial and a selector bar is provided above the dial.

The left control knob is the "ON", "OFF" and "VOLUME" control. The ring around the left knob controls the tone. Turned to the left, bass tones predominate—turned to the right, treble tones are accentuated.

Pushing in on the right knob raises the antenna; pull-

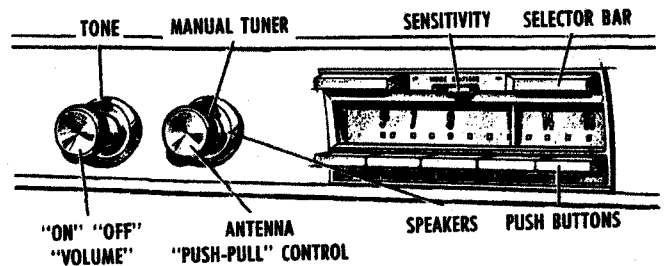

ing out lowers the antenna. The ring around the right knob controls the operation of the front and rear speakers. Counterclockwise rotation accentuates the rear speaker. Clockwise movement accentuates the front speaker. Balanced sound can be obtained by centralizing the ring.

Manual tuning of either set is accomplished by turning the right control knob to set the pointer at the desired frequency on the dial.

The five push buttons can be pre-set to favorite stations. Tune in the desired station nearest the left end of the dial with the manual tuner knob. Fine tune until best reception is obtained. Pull the first button on the left straight out, then push the button all the way in. The first button will now select that station repeatedly. Continue this process for setting the remaining buttons on other stations.

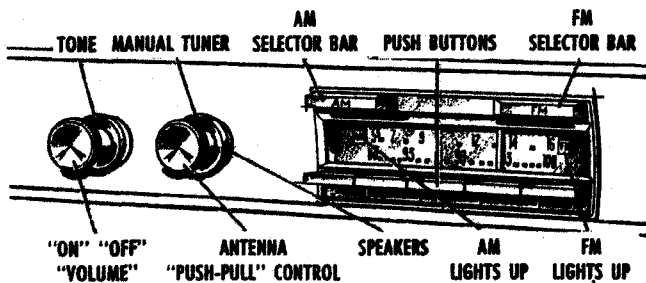

Push buttons on the AM-FM radio may be set on AM stations, FM stations, or a combination of both.

The selector bar above the dial is used on the AM-FM radio to select the desired frequency band. Pressing the left end selects the AM band and pressing the right end, the FM band. The letters "AM" or "FM" will light on the dial to show which frequency band the radio is on.

The selector bar (more stations) on the AM radio only, permits automatic search tuning. Press the bar and immediately release it to cause the tuner to change and stop at the next station on the dial. A sensitivity control for this automatic tuning is located in the center below the bar. Moving this control to the left allows the tuner to stop only on more powerful stations. In the middle position, stations of slightly lower power will be received in addition to stronger stations. To obtain maximum sensitivity, and bring in weaker stations, move control to the right.

The FM receiver is normally free from most atmospheric and man-made static. The effective range of FM transmitters, however, is usually limited to no more than line-of-sight from the transmitter—or about twenty miles. Moving out of this effective range will produce a "flutter" or a series of noise bursts in the signal. Ignition interference from adjacent vehicles may also be encountered. When it is not possible to eliminate these effects by re-tuning, try switching to a stronger FM station or to the AM band.

FRONT SEATS

Manual adjustment

The front seat can be adjusted forward or rearward. Merely move the lever forward on the driver's side of the seat and adjust to the most comfortable driving position. Then release the lever to lock the seat in this position. If you desire, the seat may be lowered by having your Authorized Cadillac Dealer remove the shims between seat supports and the floor.

Power front seat controls

The controls for electrically operated seats (optional on some models at extra cost) are mounted on the side of the seat cushion panel to the left of the driver. The seat control on the Fleetwood Seventy-Five sedan and limousine is located on the left side of the steering column lower cover.

For forward and backward adjustment of the two-way electrically controlled seat, move the switch lever in the direction of the desired seat movement.

Adjust the six-way power seat as follows: move the switch lever forward or backward to control the horizontal fore and aft movement of the seat.

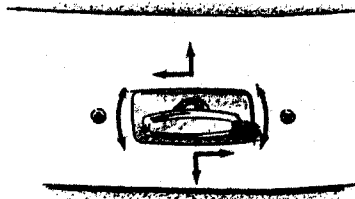

Move the switch lever up or down to control the vertical movement of the seat. Rotate the switch lever clockwise to lower and counterclockwise to raise the rear of the seat and to tilt the seat back accordingly.

Additional rearward seat positioning can be made available with all bench type seats by having your dealer reposition the seat one inch rearward at the attachment to the floor.

Bucket seats

On cars equipped with bucket seats, electrical controls are provided for fore and aft movement of the seats. The controls are located on the outboard side of the seat cushion panels.

Four-way movement of the driver's seat is provided as standard equipment only on the Fleetwood Eldorado Convertible. The four-way movement feature of the driver's seat is optional at extra cost on other cars with bucket seats.

Seat belts

Your car is equipped with two front seat belts. Rear seat belts are optional at extra cost as well as an additional front or rear seat belt for a third passenger.

The outboard webbed strap on each front seat belt is retractable for convenient storage. When buckling the belt, make certain the retractable strap is pulled all the way out of the retractor drum to provide maximum restraint.

To fasten the belt, insert the metal portion on the end

of the retractable strap into the buckle. Pull on the free end of the belt to tighten it. Tilting and pulling the buckle loosens the belt. See instructions for belt adjustment on underside of buckle. To release the buckle, depress the Cadillac Crest on the front of the buckle.

CAUTION: Proper use and care of your seat belts is important. Avoid the following unsafe conditions:

- (a) Wearing seat belts loosely or with slack in the system.
- (b) More than one person per belt.
- (c) Bleaching or redyeing webbing. (Use mild soap and water for cleaning the nylon webbing).

POWER WINDOWS

Master controls for the electrically operated windows (optional on some models at extra cost) are located on the left front door armrest. The control switches are positioned to correspond with the windows they control: the left front switch for the left front window, etc.

There are individual controls at each window. The control for the right front window is located on the right door armrest. Controls for the rear door windows are on the rear door armrests or trim pads.

The rear quarter windows on coupe styles are individually controlled by switches located on the rear armrests.

Window lock switch

A window lock switch is standard on all cars equipped

with power windows except the Fleetwood Seventy-Five sedan and limousine. The window lock switch is located forward of the power window switches. This switch has three positions marked "EMERG.," "LOCK," and "NORMAL."

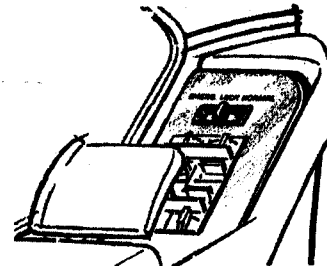

In the "NORMAL" position with the ignition "ON," all windows may be operated by the master switch or each individual switch. To prevent passengers from operating any windows, as in the case with small children in the car, place the switch in the "LOCK" position. Only the master switch will remain operative.

The "EMERG." (emergency) position permits energizing the master switches with the ignition "OFF," but only while it is *held* in the "EMERG." position. This will permit lowering or closing the windows without turning the ignition key "ON." All window switches, including the master switch, are inoperative in the "NORMAL" or "LOCK" position with the ignition "OFF."

Power vent windows

Electrically operated vent windows are standard on some models and optional at extra cost on other models. Control

switches for both front vent windows are located on the left armrest. There is also a switch for the right-hand vent window on the right armrest.

On the Fleetwood Sixty Special Sedan, master switches for both rear vents are located on the left front door armrest. Individual controls are on the armrests of the rear doors.

LOCKS

Manual door locks

Each door on your Cadillac can be locked from the inside by pushing down the door lock button. Doors may also be locked from the outside with this button by pushing the button down while the door is open, and then holding the door handle opening button all the way in while closing the door. As a security feature, locks on the rear doors of sedans are set so that both inside and outside door handles are inoperative when the lock button is depressed. To open a door, lift the lock button before operating the door handle.

Power door locks

If your Cadillac is equipped with power door locks (optional at extra cost) all doors can be locked or unlocked automatically from inside by operating either front door lock button. Push the button down to lock all doors, and pull the button up to unlock the doors. All doors can also

be locked or unlocked automatically from the outside by turning the key in the lock cylinder of either front door. In addition, all doors can be unlocked automatically by operating either front door inside handle.

Rear doors on sedans equipped with power door locks will not unlock or open with the inside door handle when the lock button is depressed, but can be unlocked individually by lifting the lock button.

Hood latch

The hood latch is operated in two steps by means of a lever. The release lever is accessible between the grille and hood panel, just to the right of center when viewed from

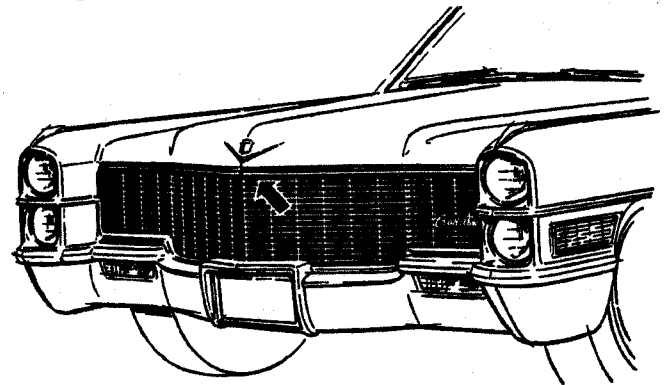

the front. Apply pressure to this lever, forcing it upward. The hood will release but will be prevented from opening further by a secondary latch. Further movement of the lever will release the secondary latch, allowing the hood to be raised. To close hood, pull hood down until it will drop of its own weight. Always check to make sure hood is properly secured.

Luggage compartment

The lid on the luggage compartment of your Cadillac is counterbalanced for easy opening. It has a key-lock release. To open, insert the key with the round head into the lock located behind the crest, turn key in a clockwise direction to release lid, then lift up on the lower edge to raise lid. An interior light goes on when lid is raised. To close, pull to a position six or eight inches from closing, remove key and push lid firmly downward. This automatically locks luggage compartment.

Power trunk lock

The power trunk lock, available on some models at extra cost, is operated by a control button located in the glove box. When the button is depressed, the trunk lid automatically unlocks and a light on the headlight switch dial face glows red, indicating that the trunk lid is unlocked. When the trunk lid is lowered, a latching mechanism pulls the lid firmly closed and locks it. In addition

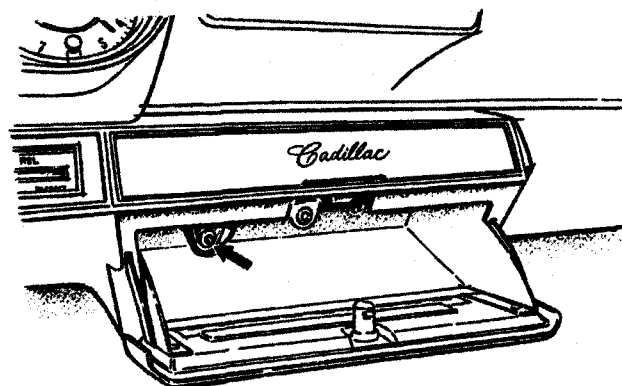

to the automatic control feature, the trunk can also be opened with a key from outside the car. To prevent damage to the closing mechanism, avoid slamming the lid when closing. Once unlocked, the lid *must* be fully opened before the pull-down and locking can be accomplished.

To help prevent thefts from the trunk; keep the glove box locked when leaving the car unattended.

AUTOMATIC LEVEL CONTROL

Automatic Level Control is standard on the Fleetwood Series, except on the Seventy-Five models, and optional

at extra cost on all other models. Automatic Level Control maintains the height of the rear of the car automatically. The leveling system responds to actual changes in load of passengers or luggage, and will compensate for loads up to 500 pounds.

CONVERTIBLE TOP

The folding top can be lowered with the rear glass window and rear quarter windows either open or closed.

To lower the top, stop the car and rotate the locking handle inboard on each side roof rail until the lock hook lever is disengaged from the striker on the windshield header.

NOTE: Do not attempt to raise top above windshield header by hand.

The power top control switch is located on the top left side of the steering column lower cover. Lift up on control switch until top is in fully lowered position.

To install top boot, place boot in position over folded top and engage boot fasteners to the studs along the body molding and on the rear quarter trim. Engage fasteners on

front of boot to studs on rear seat back panel. Press down on forward edge of boot to secure hook and pile fastener.

To raise the top, always stop the car first. Then turn down sun visors, and un-snap top boot. Press down on control switch until top is fully raised and guide studs on lock assemblies are engaged in striker holes

on windshield header. Rotate each locking handle out-board until lock hook lever is fully engaged with striker on windshield header and handle is parallel with side roof rail.

NOTE: Be sure top is securely locked to windshield header before starting car in motion.

For detailed information and instructions on the operation and care of the folding top, refer to the Convertible Top booklet in the glove compartment of all convertibles.

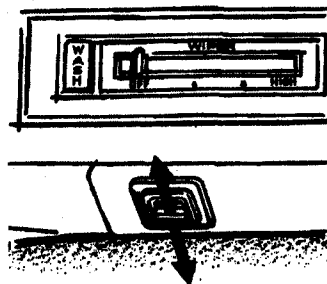

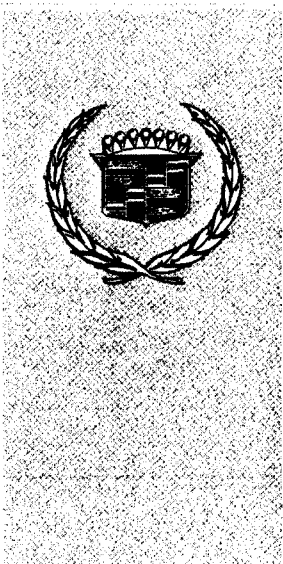

FLEETWOOD SEVENTY-FIVE SEDAN AND LIMOUSINE

GENERAL

The Cadillac Fleetwood Seventy-Five represents the finest in formal motoring. Both the Sedan and Limousine styles embody many fine features not found in other models.

An extraordinary complement of powered conveniences accent the luxury of the Fleetwood Seventy-Five. Brakes and steering, window regulators and front seats are power assisted. A remarkably smooth Turbo Hydra-matic transmission supplies an effortless flow of power. And its long 149.75 inch wheel-base and more than twenty foot over-all length provide exceptional riding comfort and spaciousness.

Additional information given here covers the operating procedures for items exclusive to Fleetwood Seventy-Five Sedans and Limousines. A complete understanding of these procedures will add to the enjoyment of your majestic 1965 Cadillac.

SECTION

3

INSTRUMENTS

The instructions on use of the ignition switch, and the various instruments, as given in Section 1, apply equally to the Seventy-Five cars, except for changes in location, as shown in the illustration of the Seventy-Five instruments and controls on the following page.

Map light

A map light is located at the center of the instrument panel under the top edge. It can be operated manually by means of the switch at the front center of the map light lens. This light also serves as an automatic courtesy light when either front door is open.

Courtesy lights

Your Cadillac is equipped with courtesy lights that illuminate the interior when any door is opened. On Limousine styles, a front compartment dome light, located in the roof above the rear-view mirror, may be turned on with the switch on the assembly. Rear compartment reading lights are provided and may be turned on with the rear light switch, located above the right rear armrest. The rear compartment lights and door courtesy lights may be turned on with the forward light switch, located above the right rear armrest.

POWER WINDOWS

Master controls for electrically operated windows are located on the left instrument panel cover extension.

Controls for the rear door windows are located in the forward portions of the rear quarter armrests. On Limousine styles, a switch is mounted on each rear armrest, in front of the window switch, to operate the partition window between the front and rear compartments.

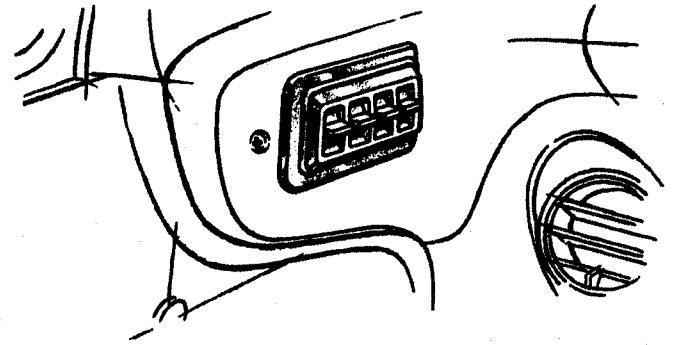

Rear vent windows

The rear vent windows may be partially opened and closed by fore and aft movement of the window knob, located above the lower garnish molding at the window.

INSTRUMENT PANEL AND CONTROLS

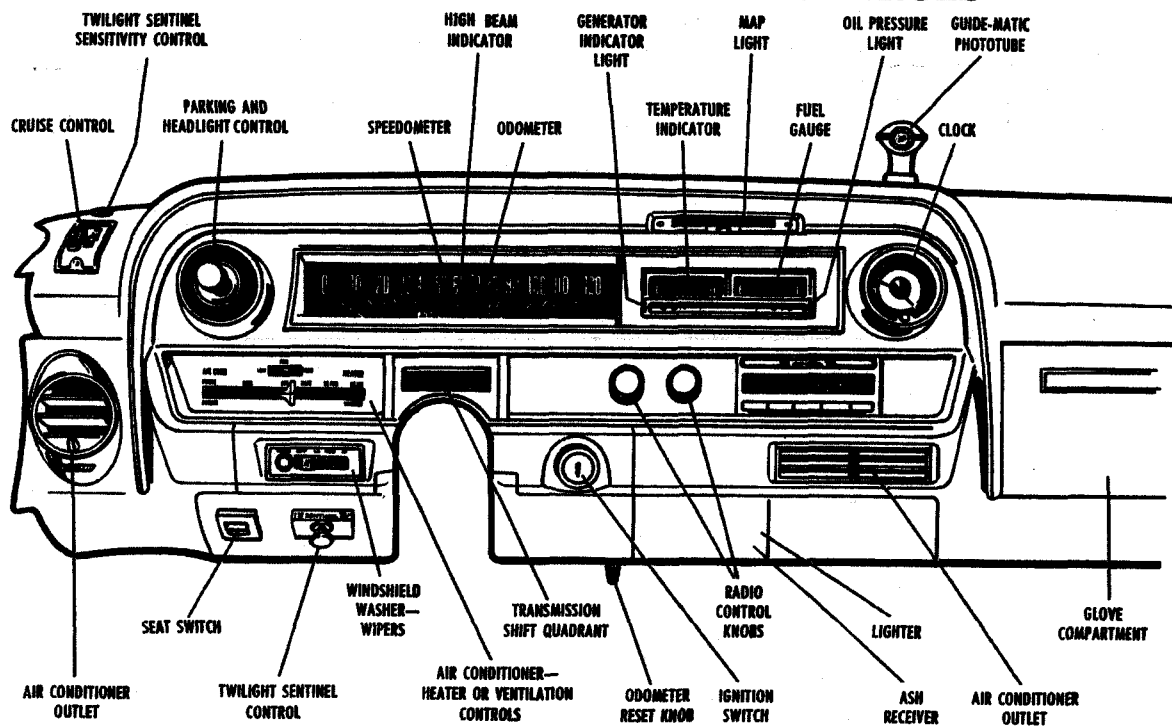

ASH RECEIVERS AND LIGHTERS

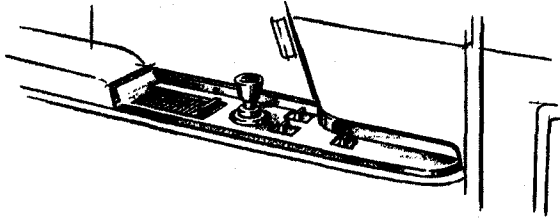

Rear ash receivers are located in the rear armrests. In addition, there are two ash receivers mounted in the center of the front seat back on either side of the rear compartment clock. A lighter is located in the left rear armrest, and also in the right rear armrest on cars without rear radio controls.

CRUISE CONTROL

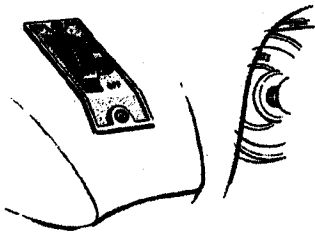

The Cadillac Cruise Control (optional at extra cost), as installed on Fleetwood Seventy-Five cars, operates in the same manner as the unit used on other 1965 Cadillacs, as described on page 19, with the following minor exceptions:

The operating controls are mounted on the left instrument panel cover extension. To use as a speed reminder, rotate the dial until the desired speed setting appears in the opening next to the word "OFF;" then move switch "ON." Adjust the dial as necessary to make the accelerator back pressure occur at the desired speed.

For automatic control, rotate dial to desired setting (if this has not already been done) and accelerate until this speed is reached and back pressure is felt at accelerator. Move lock-in switch forward while holding back-pressure; then release the switch. The car will now maintain the speed selected.

Automatic control is disengaged by depressing brake pedal or moving switch to "OFF" position. To re-engage, move switch to "ON" position, and repeat the above procedure.

TWILIGHT SENTINEL

Twilight Sentinel (optional at extra cost) automatically turns on your car's headlights, instrument panel lights, and tail lights as darkness approaches, when the ignition switch

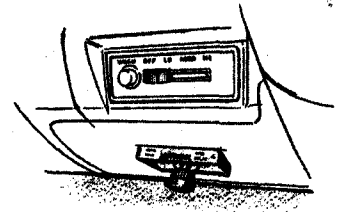

is "ON". Similarly, the unit turns the lights off as daylight approaches.

For automatic control, push in the Manual-Automatic control knob to the left of the steering column below the dash. Leave the headlight control switch in "OFF" position for automatic operation. A photo-electric cell cap located on the left instrument panel cover extension marked "EARLY" and "LATE" permits adjusting Twilight Sentinel Control sensitivity to suit driving conditions. Turning the photo-electric cell cap toward "EARLY" direction causes the lights to turn on early as darkness approaches; turning toward "LATE" causes the lights to come on later.

A variable time delay feature permits the headlights and tail lights to remain "ON" after the ignition switch is turned "OFF" for added convenience in darkened areas. Additional side lighting can be obtained by activating a cornering light with the turn signal lever. For time delay action, rotate the control knob clockwise to the position that provides the desired time delay. (Manual-Automatic control knob must be pushed in.) Maximum time delay action is approximately 90 seconds.

For manual operation of the headlights, pull out on the Twilight Sentinel knob, as indicated on the chrome bezel. This permits conventional operation of lights with the headlight control knob.

REAR HEATER CONTROLS

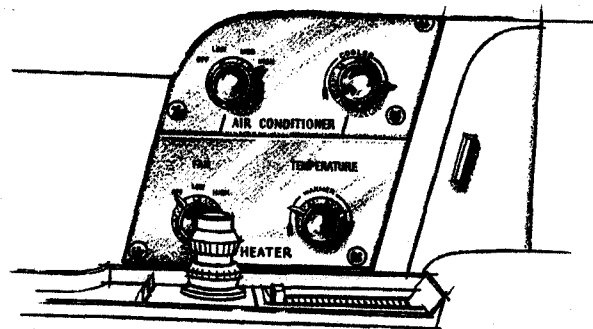

The heater control panel for the rear compartment heating system is located behind a sliding door above the right rear armrest. The controls consist of a fan switch to regulate fan speed and a temperature knob to control rear compartment temperatures. The fan switch turns the rear heaters on and off. It also controls the amount of air being discharged through the rear heaters and may be operated on either of two speeds—"LOW" or "HIGH". To increase the temperature, rotate the temperature knob clockwise in the direction of the arrow; to reduce the temperature, rotate the knob counterclockwise.

AIR CONDITIONING SYSTEM

The Cadillac Fleetwood Seventy-Five air conditioning system is designed to provide cool, dehumidified air to lower the temperature of the car interior to a comfortable level. The front compartment cooling unit is located on the right cowl and delivers air into the front passenger compartment.

A separate cooling unit is mounted in the trunk compartment. This unit delivers cooled air to rear seat passengers through two outlets mounted in the roof.

AIR CONDITIONER CONTROLS

The air conditioner control panel for the front compartment is located in the instrument panel to the left of the steering column. A switch on the upper center of the control panel regulates blower speed. There are two horizontal sliding levers. The upper lever controls the air flow for the operation of the air conditioning, heating and defrosting systems. The lower lever controls the air temperature.

Moving the upper lever to the "COOL" position turns the system on and provides cooled outside air. For maximum cooling efficiency on hot or humid days, advance the upper lever to the "RECIRC" position. In this position, a small amount of outside air is mixed with the recirculated air. Moving the lower lever to the left reduces air temperature; moving it to the right increases air temperature.

For maximum cooling, move the lower horizontal sliding lever to the extreme left-hand position, turn the blower on "HIGH", and slide the upper lever to "RECIRC." If the weather is not too humid, it is recommended that the upper lever be maintained in the "COOL" position at all times. This will assure fresher air under most conditions and will reduce the accumulation of objectionable odors. If the air becomes too cool, turn the blower to a lower speed, or move the lower sliding lever to the right.

Rear compartment controls are located just above the rear heater controls behind the sliding door above the right rear armrest. The unit may be turned on and off and air volume may be controlled by the fan switch. To reduce the temperature, rotate the temperature knob clockwise; to increase the temperature, rotate the knob counterclockwise.

The two rear outlets located in the rear roof are equipped with a number of small openings for providing diffused cooled air. Each outlet is equipped with a door that may be opened to direct air toward the rear passengers.

REAR COMPARTMENT RADIO CONTROLS

A rear seat radio remote control is optional at extra cost on cars equipped with a signal seeking selector radio. It is mounted in the right rear armrest and consists of an on-off volume control, a sensitivity control and a station selector button.

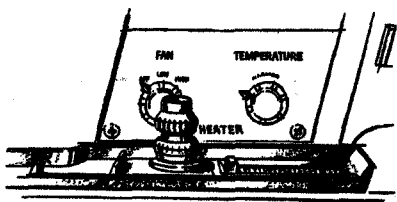

With the rear seat radio switch on, only the rear controls operate the radio. The radio cannot be operated normally from the front seat again until the rear control is turned off.

The on-off volume control knob turns the radio on and off and regulates the volume. When the rear seat radio remote control is on, the station selector button glows red. The sensitivity control is below the on-off knob. Rotating it counterclockwise will permit the tuner to stop only on the more powerful stations. In the middle position, stations of slightly lower power will also be received. For maximum sensitivity, rotate the control clockwise to bring in the weaker stations. To select stations, momentarily depress the station selector button located between the rear door window control switches.

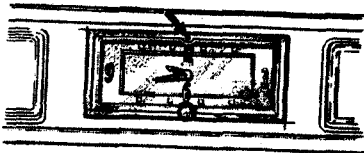

ELECTRIC CLOCKS

Two electric clocks are provided, one on the right side of the

instrument cluster, the other in the center of the front seat back. The rear clock may be manually regulated by turning the small regulator screw clockwise to make the clock run faster and counterclockwise to make it run slower.

For explanation of the front clock resetting procedure, refer to item on "Electric Clocks" on page 11.

HOOD LATCH

The hood latch is operated in two steps by means of a lever and a separate secondary latch. The release lever is accessible beneath the center horizontal grille bar just to the left of center when viewed from the front. Apply pressure to this lever, forcing it to the right. The hood will be released but prevented from opening by the secondary latch. Reach in at the hood opening at the center and

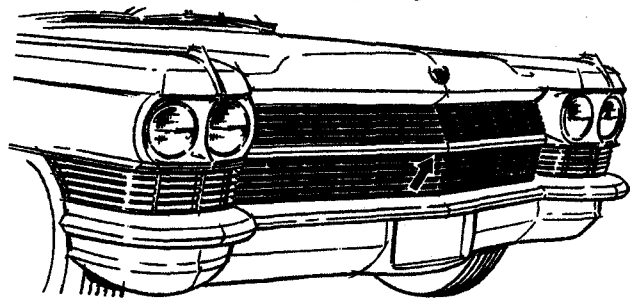

force the secondary latch upward to the limit of its travel. Hold in this position and raise the hood. To close the hood, pull it down until it drops of its own weight. Always check to make sure the hood is properly secured.

EMERGENCY WHEEL CHANGING INSTRUCTIONS

The jack components are stowed in the luggage compartment. The jack and jack handle are in a carton and the wheel wrench is stowed beneath the spare tire.

CAUTION: On cars equipped with a Controlled Differential, do not jack one rear wheel off ground with the engine running.

1. If at all possible, have the car on level ground off the highway.
2. Remove jack components and spare tire from luggage compartment.
3. Place transmission lever in PARK position, set the parking brake and **BLOCK THE WHEEL DIAGONALLY OPPOSITE THE FLAT TIRE.**
4. Locate the jack under the sill near the door openings, front or rear, in either of the positions indicated in the drawing. (When lifting the rear of a Commercial Chassis, position the jack in the same location under the frame side rail.)
5. Raise car until tire is just touching the ground, re-

move front wheel disc or wheel shield and rear disc. Use thin tip of jack handle to remove wheel disc. To remove rear wheel shield, turn the locking rod tab, located at center of the lower edge of the shield. Place jack handle on locking rod tab (handle pointing rearward on left side or forward on right side), then rotate handle outward to loosen locking rod. Tip shield outward at the top while raising up and away from the mounting hooks.

6. Loosen wheel nuts a half turn (counterclockwise).

7. Raise car until wheel is off the ground, remove mounting nuts and lift wheel off hub.

8. Reverse procedure to install wheel. Make certain wheel mounting nuts are tightened securely. Use rubber covered portion of jack handle to install wheel disc.

CAUTION: The jack supplied is intended for use only on this vehicle and only for wheel changing purposes.

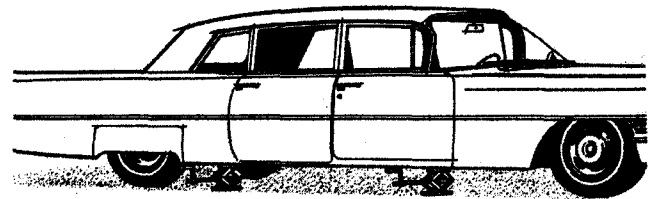

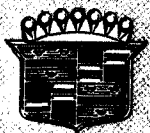

SERVICE FOR YOUR CAR

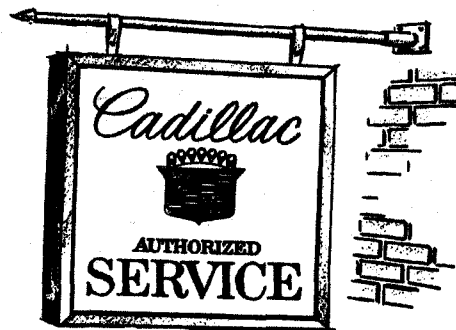

AUTHORIZED CADILLAC SERVICE

SECTION

4

Warranty

When purchased new, your Cadillac is covered by the Manufacturer's New Vehicle Warranty and the Policy on Cadillac Owner Service, both of which are explained in your Owner Protection Plan booklet given to you by your Authorized Cadillac Dealer at the time of delivery.

Basically, the manufacturer warrants the car, with the exception of the battery, tires, and normal maintenance items, for a period of 24 months or 24,000 miles, whichever occurs first, from the date of delivery to the original owner by an Authorized Cadillac Dealer. This warranty applies to the replacement of parts not necessitated by accident, abuse, or lack of recommended maintenance as explained in the Owner Protection Plan booklet.

Required adjustments are normally made by your Authorized Dealer during the new car preparation operations. Any required service adjustments that do not involve the replacement of a part will also be made at no extra charge by any Authorized Cadillac Dealer for a period of 90 days or 4,000 miles. After that period, service adjustments are chargeable as maintenance.

Protect-O-Plate

The Protect-O-Plate on the inside back cover of your Owner Protection Plan booklet contains identification data pertaining to your new Cadillac. A second plate, containing your name and address and delivery information will be mailed to you. Please attach this second plate in the space provided just as soon as it arrives.

This combination of plates, properly placed in your Owner Protection Plan booklet, will speed up the writing of repair orders when you bring your car in for service. It will also provide all needed identification data should warranty work be required.

Owner responsibility

Your new Cadillac, like all fine machinery, requires regular care to maintain its peak performance and preserve its showroom appearance. Periodic maintenance assures you of many miles of carefree driving, and protects your investment. A recommended maintenance schedule is in-

cluded in the Owner Protection Plan booklet.

Cadillac service

Authorized Cadillac Dealers are well qualified to assist you in the maintenance of your car because their service personnel have the advantages of:

1. Specialized Cadillac training at General Motors Training Centers.
2. Special tools and equipment designed for Cadillac products.
3. Genuine parts that are engineered for your Cadillac.
4. Factory product information and factory-dealer cooperation that contribute to efficient service and the latest in mechanical procedures.

For the best in Cadillac Guardian Maintenance service, take your Cadillac to an Authorized Cadillac Dealer.

FUEL

The best fuel for your Cadillac

The 1965 Cadillac engine requires a fuel with an octane rating of at least 100 Research Method and 89 Motor Method at sea level. Use of low octane fuels will result in severe engine knock, with possible damage to major engine parts.

Engine detonation—known as spark knock or “pinging”—generally indicates the fuel's octane rating is below engine requirements. If “pinging” persists, even when the

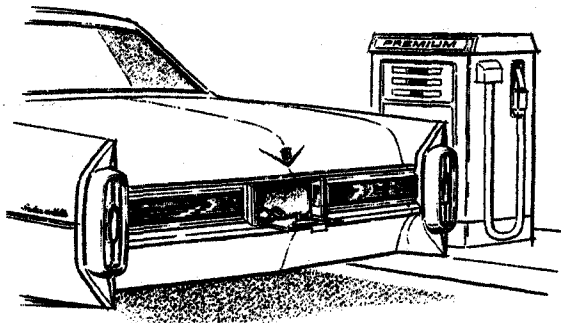

best available fuel is being used, see your Authorized Cadillac Dealer.

The manufacturer regards engine damage caused by use of fuels of insufficient octane as engine misuse, for which the manufacturer is not responsible under the terms of the manufacturer's New Vehicle Warranty. Always specify a gasoline that will meet engine requirements.

Do not be alarmed if the car loses power at fairly high altitudes. This is normal with reduced air density.

Warning
on operation in foreign countries
IF YOU PLAN TO OPERATE YOUR CADILLAC IN MEXICO, OR OTHER FOREIGN COUNTRIES,

WITH THE EXCEPTION OF CANADA, YOU MAY FIND AVAILABLE FUELS SO LOW IN OCTANE THAT EXCESSIVE KNOCKING AND SERIOUS ENGINE DAMAGE RESULT FROM THEIR USE. TO MINIMIZE THIS POSSIBILITY, MAKE CERTAIN THAT FUELS OF SUFFICIENT OCTANE VALUE ARE AVAILABLE. BEFORE TAKING YOUR CADILLAC OUTSIDE THE UNITED STATES OR CANADA, WRITE TO CUSTOMER SERVICES SECTION, SERVICE DEPARTMENT, CADILLAC MOTOR CAR DIVISION, DETROIT, MICHIGAN 48232, GIVING:

1. your car's Vehicle Identification Number (located on the white plastic tag on the left front door lock pillar).
2. the countries in which you plan to travel.

You will be furnished details of adjustments or alterations which should be made to the engine by your Authorized Cadillac Dealer before your departure. Failure to make the necessary changes, and subsequent operation under conditions of continuous or excessive knocking, constitute misuse of engine for which manufacturer is not responsible under terms of the manufacturer's New Vehicle Warranty.

After arriving in a foreign country, contact the nearest Authorized General Motors Dealer for brand names of the best fuels available and for advice as to where they can be purchased.

Gasoline tank

Capacity of the fuel tank is approximately twenty-six gallons on all styles except the Commercial Chassis which has a twenty gallon capacity fuel tank. The gasoline filler cap is located behind the rear license plate. Pull out on the top of the plate to open.

Positive crankcase ventilator

There are two types of Positive Crankcase Ventilator systems used to reduce air pollution by recycling crankcase fumes back to the intake manifold for burning. The closed system, installed on cars shipped to the state of California, uses a non-ventilated oil filler cap, an air cleaner strainer, and an external hose and pipe between the air cleaner and the left rocker arm cover. The system installed on all other cars uses a ventilated oil filler cap equipped with a filter.

Under no circumstances should an oil filler cap from a closed system be used on other cars or serious engine damage will result.

Specific maintenance requirements must be followed to permit satisfactory operation of each system. It is extremely important that required maintenance be performed or engine damage will result and the advantages of positive crankcase ventilation will be lost.

Maintenance is required every 12,000 miles or twelve months, whichever occurs first. Consult your Authorized

Cadillac Dealer who is familiar with the proper care of these devices.

ENGINE

Your Cadillac engine requires four quarts of oil on a refill after the crankcase has been drained. One additional quart is required when the oil filter is changed. Proper oil level should always be maintained within the driving range marked on the oil dipstick. Each time you buy gasoline have the oil level checked after first allowing a few minutes for the oil to drain back into the oil pan. Add one quart when the level drops to the "ADD OIL" mark—NOT BEFORE. Do not operate the car with the oil level above the "FULL" mark.

Initial oil fill

The oil used to fill the crankcase at the factory is a high quality oil that meets General Motors Standard GM 4745-M. This factory-fill oil should be left in the engine for the normal time and mileage interval as specified in the table on page 40. During the first interval, it is particularly important to have the oil level checked each time you buy gasoline since most modern, high-compression engines require a break-in period for the oil usage to stabilize.

Engine oil recommendations

Use of the proper engine oil is your best assurance of continued reliability and performance from your Cadillac

engine. It is recommended that you use an oil which, according to the label on the can, is: (1) intended for service "MS", and (2) passes car makers' tests or meets General Motors Standard GM 4745-M. Your Authorized Cadillac Dealer will be pleased to assist you in selecting the proper oil.

Winter operation

In areas where the temperature seldom goes below zero, most 10W oils provide the desired starting characteristics. Where the temperature is frequently below zero, a 5W or 5W-20 oil is recommended.

ENGINE OIL CHANGE AND VISCOSITY RECOMMENDATIONS

The change interval shown in the following table is based on oils that meet the requirements stated under "Engine Oil Recommendations". The table will serve as a guide for selecting the proper oil change interval and the cor-

rect oil viscosity at prevailing temperatures. It is not necessary to change oil for the unseasonably cold or warm day encountered during Fall or Spring.

Anticipated Lowest Temperatures	Use SAE Viscosity Number	Change Your Oil*
Above Freezing (+32° F.)	SAE 20W SAE 10W-30	Every 60 days or 6,000 miles, whichever occurs first.
Below Freezing (+32° F.) and above 0° F.	SAE 10W SAE 10W-30	Every 60 days or 6,000 miles, whichever occurs first.
Below 0° F.	SAE 5W SAE 5W-20	Every 60 days or 6,000 miles, whichever occurs first.

*If there is danger of oil contamination by dust, water or other foreign material during very extreme driving conditions, the oil should be changed more frequently than shown in the table. Your Authorized Cadillac Dealer is well qualified to advise you.

ENGINE COOLING

Your Cadillac's cooling system has been designed to maintain efficient engine operating temperatures. Check coolant level at each engine oil change to make certain proper coolant level is maintained. The system should be checked COLD. When coolant level drops one inch below the "Fill Cold" mark on the front of the radiator below the filler cap, fill only to "Fill Cold" mark. On Fleetwood Seventy-Five models, maintain coolant level $\frac{3}{4}$ inch above cooling tubes in top of upper radiator tank. Do not overfill. Keep the system leak-free by having all connections checked regularly.

Refer to page 42 for the capacity of your car's cooling system.

Important safety note

Avoid removing the filler cap while the engine is at normal operating temperature, since hot coolant will spray out. This is a normal action for all pressure-type cooling systems. Should it become necessary to add coolant, place a cloth over cap, rotate cap toward left until first stop is reached, and allow pressure to escape. Then turn again to left to remove. Be sure cap is turned tightly when re-installed.

The temperature gauge can sometimes register "H" (Hot) under severe operating conditions. However, this is not necessarily cause for alarm unless accompanied by a

buzzing noise from the radiator cap or by loss of coolant by boiling.

CAUTION: If temperature gauge indicates above-normal temperature, make certain engine is running, or is allowed to cool down to normal temperature, before adding coolant.

If gauge continues to register above normal with coolant at correct level, have your Authorized Cadillac Dealer make a thorough check of the system.

Cooling system protection

The inhibited year-around (permanent type) engine coolant used to fill the cooling system at the factory is a high quality solution that meets General Motors Specification 1899-M. This factory-fill coolant solution is formulated to withstand two full calendar years of normal operation without draining or adding inhibitors, and provides freezing protection to -20°F .

It is the owner's responsibility to keep the freeze pro-

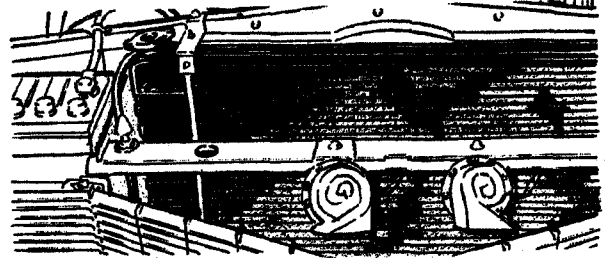

COOLING SYSTEM CAPACITY	
All cars except Fleetwood Seventy-Five with heater only	18 qt.
with Air Conditioner	19 qt.
Fleetwood Seventy-Five with heater only	19½ qt.
with Air Conditioner	20½ qt.
All Cars without heater or Air Conditioner	16 qt.

tection at a level commensurate with the area in which the vehicle will be operated. *Regardless of climate*, freezing protection should be maintained at least to 0°F., to provide adequate corrosion protection. When adding solution due to loss of coolant for any reason or in areas where temperatures lower than -20°F. may occur, a sufficient amount of ethylene glycol base coolant compatible to GM Specification 1899-M should be used.

Every twenty-four months, the cooling system should be serviced by flushing with plain water, then completely replacing the coolant with a fresh solution of high-quality, inhibited (permanent type) coolant meeting GM Specification 1899-M, and providing freezing protection at least to -20°F. At this time, also add GM Cooling System Inhibitor and Sealer or equivalent. In addition, Cooling System Inhibitor and Sealer should be added every fall after the car has been driven 24,000 miles. GM Cooling System

Inhibitor retards the formation of rust or scale and is compatible with aluminum components.

NOTE: Alcohol base coolants are not recommended for your Cadillac at any time.

Windshield washer solution

A proper mixture of GM Windshield Washer Anti-freeze and Gas Line De-Icer or equivalent, should be added to your windshield washer container during cold weather to retard freezing. NOTE. The washers may not operate effectively at extremely low temperatures or while traveling at high speeds.

PREVENTIVE MAINTENANCE



Preventive maintenance for your Cadillac is based on the Manufacturer's recommendations. Details are outlined in the Cadillac Owner Protection Plan booklet. Consult your dealer for additional services that may be needed due to local climatic conditions or driving habits.

Suspension

The suspension and steering linkage connections do not require periodic lubrication. Suspension connections are packed with a special long-life lubricant and normally need repacking only when damaged seals are replaced. Steering linkage pivots must be replaced when worn or loose.

Carburetor air cleaner and filter

The carburetor air cleaner should be inspected for dust leaks every Spring and Fall. Inspect more frequently if the car is operated in dusty areas. Install a new filter element if needed at time of inspection, or at least every 30,000 miles. The element should not be cleaned.

Oil filter

A full-flow type oil filter is used on the Cadillac engine. It is recommended that it be replaced every 6 months or 6,000 miles, whichever occurs first. The filter change should be performed with an oil change.

Fuel filter

The fuel filter element should be replaced at least every Spring and Fall. More frequent service is necessary under unusual operating conditions. The filter element stops small dirt particles that may cause carburetor flooding.

Transmission fluid and strainer

The bottom pan should be drained every 24,000 miles or 2 years, whichever occurs first, and new fluid added. For cars in commercial use, and those subjected to heavy city traffic during hot weather or when the engine is idled for long periods, the bottom pan should be drained every 12,000 miles.

The strainer should be replaced only after the first 24,000 miles or 2 years, whichever occurs first.

Manufacturer-recommended fluids and lubricants

TRANSMISSION AND POWER STEERING SYSTEM

Automatic transmission fluid designated "AQ-ATF", followed by three or four numerals and the suffix letter "A", or GM Automatic Transmission Fluid available from Authorized Cadillac Dealers.

BRAKE SYSTEM

SAE approved heavy-duty brake fluid or equivalent.

CONTROLLED DIFFERENTIAL

Special GM Controlled Differential Lubricant available from Authorized Cadillac Dealers.

FRONT SUSPENSION

Special lubricant used. Periodic inspection only. See your Authorized Cadillac Dealer.

HOISTS—SERVICE LIFTING EQUIPMENT

The preferred type of hoist for lifting all 1965 Cadillac cars is one that engages the front suspension and rear axle, or all four wheels. A frame contact hoist may be used on most models when certain precautions are observed. Do NOT use a frame contact hoist to raise the Fleetwood Seventy-Five sedan and limousine.

When using lifting equipment that engages the suspension on Fleetwood Seventy-Five sedans and limousines, center car over hoist so that hoist arms are adjacent to, and outboard of, support plates on front lower arms.

When using lifting equipment that engages the suspension on cars with the perimeter-type frame, the car should be centered over hoist so that hoist arms engage outboard, flattened portion of front suspension lower arms.

EMERGENCY WHEEL CHANGING INSTRUCTIONS

The jack supplied with your Cadillac is intended for use only on this vehicle and only for wheel changing purposes.

On cars with a shelf-mounted spare wheel and tire, the jack hook and rack bar are stored on the shelf in the luggage compartment just forward of the spare wheel. The jack base is stored on top of the spare wheel (secured by a through-bolt and wing nut) and the jack handle is stored under the tire.

The spare wheel and tire on convertible styles is floor-mounted and the jack components are stored on the right side of the luggage compartment.

To change wheel, proceed as follows:

CAUTION: On cars equipped with a Controlled Differential, do not jack one rear wheel off ground with engine running.

1. If it is at all possible, park car on level ground, off the highway.
2. Place transmission lever in PARK position and set parking brake.
3. Remove spare tire and jack components from luggage compartment.
4. **BLOCK THE WHEEL DIAGONALLY OPPOSITE THE FLAT TIRE.**
5. Install rack bar in jack base.

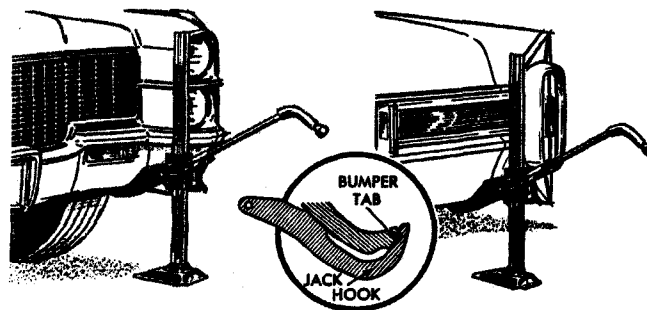

6. Engage the jack hook on the tab located behind the bumper seams (front or rear) as shown. **IMPORTANT: THE HOLE IN THE JACK HOOK MUST ENGAGE WITH THE TAB ON BACK OF BUMPER AT THE SEAM AREAS.**

7. Raise jack until snug and reposition so that rack bar is approximately vertical. (On slopes, shift the jack base in the downhill direction until the rack bar is positioned vertically or pointing slightly uphill).

8. Remove front wheel disc or rear wheel shield and rear disc. Use tip of jack handle to remove wheel disc. Remove rear wheel shield by turning the locking rod tab located on center lower edge of shield. Place jack handle on locking rod tab (handle pointing rearward on left side or forward on right side), then rotate handle outward to loosen locking rod. Tip shield outward at the top while raising up and away from the mounting hooks.

9. Loosen wheel nuts $\frac{1}{2}$ turn (counterclockwise).

10. Jack car until tire is off ground, remove mounting nuts and lift wheel off hub.

11. Reverse procedure to install wheel. Make certain wheel mounting nuts are tightened securely. Use rubber covered portion of jack handle to install wheel disc.

NOTE: For wheel changing instructions of Fleetwood Seventy-Five sedans and limousines, refer to Section 3, Page 35.

TIRES

The original equipment tires are engineered specifically for your 1965 Cadillac. When replacement is necessary, specify original equipment type tires of the correct size.

Tire maintenance

Avoid abusive treatment. Do not exceed tire loadings beyond those specified in the chart for extended periods. **MAINTAIN CORRECT INFLATION PRESSURE.**

The tire inflation pressures are for cold tires. After a long or hard drive, pressures may be as much as six pounds higher than shown in the chart.

Tire rotation

Tire rotation is not essential under normal driving conditions, but is desirable if abnormal tire wear is observed. If abnormal tire wear is evident, the condition causing such wear should be determined and corrected. The correction may include interchanging tires. Under certain driving conditions, such as fast cornering, it may be desirable to interchange tires regularly.

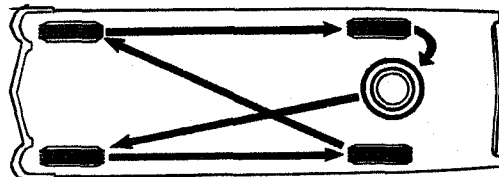

Tire pressures (when checked cold)

Tire Size	Ply Rating	Normal Load (Up to and Including)	Normal Load		*Max. Pressure Special Service	
			Front	Rear	Front	Rear
8.00 x 15—Blackwall (Except Limousines and Commercial Chassis) 9.00 x 15—Whitewall (Except Limousines and Commercial Chassis)	4	6 passengers plus 200 lbs. luggage	26	26	30	30
	4		24	24	28	28
9.00 x 15—Black or White (Except Limousines and Commercial Chassis)	6	5 passengers 9 passengers plus 200 lbs. luggage	24	24	28	28
8.20 x 15—Black or White (Fleetwood Seventy-Five Limousine only)	8		28	28	28	30
			28	34	28	38
8.90 x 15—Black or White (Commercial Chassis only)	8	Normal loading Extra equipment loading— not to exceed 7200 lbs.	24	32	—	—
			26	40	—	—

* Sustained high speeds above 80 MPH or for vehicle loadings above normal capacity

UNDERCOATING

Undercoating should not be applied to any moving or rotating part. It should be kept off air conditioner fittings and lines, body and antenna drainholes, and exhaust systems. On cars equipped with Automatic Level Control, particular care should be taken not to undercoat any fittings, lines, or system components.

APPEARANCE MAINTENANCE

Your Cadillac is finished with General Motors "Magic-Mirror" acrylic lacquer. This is a finish of maximum beauty which, in depth of color, gloss retention and durability, is

superior to conventional lacquer finishes.

Washing

The best way to preserve the finish is to keep it clean. Frequent washings are required to maintain its original beauty. Wash the car with either warm or cold (never hot) water, not in the direct rays of the sun, and not while the sheet metal surfaces are hot. Never wipe dirt from dry painted surfaces because this may scratch the finish. The use of strong soaps and chemical detergents should be avoided. All cleaning agents should be promptly flushed from the surface and not allowed to dry or they may streak the finish.

Polishing and waxing

Even though the acrylic paint on your car is more durable than conventional finishes, under certain conditions you may wish to wax or polish your car to provide maximum protection.

Calcium chloride and other salts, ice-melting agents, road oil and tar, tree sap, chemicals from factory chimneys and other foreign matter may damage any automobile finish if allowed to remain in contact with paint.

Prompt washing may not thoroughly remove these deposits and, particularly in geographical areas where these exposure conditions are severe, properly applied high quality polishes and waxes will provide the best protection. Authorized Cadillac Dealers offer both GM Magic Mirror and Blue Coral, which have proven their value in maintaining a fine finish.

NOTE: Some chemical cleaners used for removing road oil and tars from painted surfaces have been found to be detrimental to acrylic finishes. When purchasing a cleaner, make sure the instructions specifically state that the contents can be safely used on an acrylic finish.

Chrome

Many parts of your Cadillac, such as the bumpers and body hardware, are chrome plated. Chromium plating is susceptible to the actions of solutions being used on streets and highways to melt ice. Corrosive damage may also be

caused by salt air near coastlines, industrial smoke and other conditions found in urban areas. When such conditions exist, frequent washing and waxing are necessary. GM Chrome Cleaner is an excellent material for cleaning the chrome on your car.

Anodized aluminum parts

Caustic cleaning agents will discolor anodized aluminum parts such as the grille and exterior trim. Do not permit the use of steam or cleaning solutions containing these agents for the cleaning of your car.

Glass

Dirt and insects can be removed from glass with clear water. Never wipe glass with dry paper or cloth. Do not operate windshield wipers when glass is dry. Periodic inspection and replacement of wiper blades reduce the possibility of glass becoming scratched and assure clear vision under adverse driving conditions.

Care should be taken when cleaning a tinted back window. The use of harsh abrasives to clean the inside surface should be avoided, as some of the tinting material may be removed. Use a mild liquid household cleaner and remove with a soft cotton cloth.

Leather

Cadillac upholstery leathers are made from select hides and are protected by a special finish. They can be kept

clean normally by regular dusting. Leather that has become soiled can be cleaned with GM Vinyl Cleaner or thick, sudsy lather made from mild soap in lukewarm water. Avoid the use of excessive amounts of water. Remove the suds with a clean, damp cloth and wipe dry. If a sheen is desired, buff with clean cheesecloth. A high quality, glycerine base saddle soap can be used, if desired.

To remove stains such as food, pet accidents and ink, clean as previously explained. For acids and perspiration stains, use cloth dipped in solution of one teaspoon of baking soda to one cup of water, and follow up with the soap and water treatment. In the event of blood stains, wipe off with cold water before using soap and water.

Do NOT use naphtha, alcohol cleaners, household cleansing and bleaching agents, wax, polish, or oils.

White sidewall tires

GM White Sidewall Tire Cleaner is recommended. Foaming type household cleansers may also be used. Do NOT use gasoline, kerosene, or any oil product that will discolor the tire sidewalls or damage the rubber.

Upholstery and carpets

Dirt and dust in the upholstery and carpets can be removed with frequent vacuuming. GM Kar Kleen is especially recommended for cleaning carpets and upholstery, and restoring them to like-new condition. GM Fabric Cleaner can be used on spots that are difficult to remove.

Fabric roof cover

A natural rubber eraser will remove most soil spots from the fabric top. To wash the top, use lukewarm water and suds from a neutral soap. A cloth or soft-bristled brush is recommended for applying the solution of suds. Deeply embedded dirt can be removed with a moist cloth or sponge and a small amount of "foaming" type cleanser. All traces of the cleanser should be removed with clean water. Do NOT use volatile cleaners, naphtha, gasoline, harsh household cleaners and detergents, soaps, and bleaching agents. A stiff-bristled brush may seriously damage the fabric top.

SPECIAL NOTES

Before storing your car

If you do not plan to use your Cadillac for thirty days or longer, consult your dealer for recommended procedures that will prevent damage to the engine and chassis.

Lights

When the headlights are on high beam a light above the 60 mph mark on the speedometer glows red. Never leave the high beam on when driving behind another car or approaching an oncoming car. Have all your lights checked regularly. Your Authorized Cadillac Dealer has the modern equipment and genuine Cadillac parts to handle these services promptly.

Exhaust gases

Poisonous carbon monoxide is always present in exhaust gases, especially when any concentration of these gases is present in the air such as in a garage, in congested traffic, or when you have stopped directly behind a vehicle with its engine running. With the air intake located just below the windshield, your Cadillac provides you with maximum protection against exhaust fumes. Exhaust gases may have strong odors which normally should give warning of their presence. However, the exhaust gases from some vehicles may not be so noticeable under certain conditions, and the senses of various people react differently. Precautions should be taken to avoid exposing yourself to the effects of these fumes. These gases contain poisonous carbon monoxide which by itself is tasteless, colorless and odorless.

Controlled differential

On cars equipped with Controlled Differential, do not jack one rear wheel off ground with the engine running.

Transmission

The "L" range should be used when going up or down very steep grades. Where traffic signs call for first or second gear always shift to "L" range.

When parking on hills or steep inclines, place the shift lever in the Park "P" position to lock the rear wheels. Also apply the parking brake and turn the front wheels

toward curb. Always move the lever to Park "P" position and apply parking brake when leaving the car with engine running, such as when opening or closing the garage door, or when assisting passengers in or out.

Applying the brakes

For safer braking of the car on ice or snow, apply the brakes intermittently rather than continuously. Ask your dealer to familiarize you with the emergency provisions of the parking brake should the hydraulic assist be insufficient for any reason, and with the method of braking with both feet on the pedal if power assist is lost.

SPECIFICATIONS

Vehicle identification number

The Vehicle Identification Number is used in license and insurance applications and in general reference to the automobile. This number is located on the rear portion of the crankcase behind the intake manifold, and on top of the frame right side rail to the rear of the radiator. For the owner's convenience it also appears on the plastic service notice plate on the left front door lock pillar.

Weight

Consult the dealer who sold you the car or the Motor Vehicle Commissioner of your state. Weight information on all body styles is regularly supplied to these authorities.

FLUID CAPACITIES

Fuel Tank—approximately 26 gallons, except Commercial Chassis—20 gals.

Turbo Hydra-matic transmission with strainer change, 3½ quarts

Engine Oil (Refill) 4 quarts; with filter change, 5 quarts

ENGINE SPECIFICATIONS

Type of Engine.....90°, V-8 overhead-valve
 Bore and Stroke.....4.130 in. x 4.000 in.
 Piston Displacement.....429 cu. in.
 Cooling System—See page 42

DESCRIPTION	STYLE NUMBER	VEHICLE IDENTIFICATION NUMBER	WHEELBASE (INCHES)
Fleetwood Sixty Special Sedan (Fleetwood Brougham option)	68069	M5100001	133.0
Calais Hardtop Sedan.....	68239	N5100001	129.5
Calais Coupe.....	68257	G5100001	129.5
Calais Sedan.....	68269	K5100001	129.5
Hardtop Sedan de Ville.....	68339	B5100001	129.5
Coupe de Ville.....	68357	J5100001	129.5
De Ville Convertible.....	68367	F5100001	129.5
Sedan de Ville.....	68369	L5100001	129.5
Fleetwood Eldorado Convertible.....	68467	E5100001	129.5
Fleetwood Seventy-Five Sedan.....	69723	R5100001	149.8
Fleetwood Seventy-Five Limousine.....	69733	S5100001	149.8
Commercial Chassis.....	69890	Z5100001	156.0

FUSES AND BULBS

Fuses and circuit breakers protect the electrical wiring in the car against overloading. All fuses are contained in a fuse panel located beneath the instrument panel to left of the steering column except the Guide-Matic fuse which is located in the amplifier harness next to the amplifier. The generator indicator light fuse on Fleetwood Seventy-Five cars is located on the dustshield near the generator, and the Cruise Control fuse is located in the harness near the brake pedal switch.

Specifications for fuses and bulbs are listed in two charts. Replacement parts should be of same type and capacity characteristics as those listed.

FUSES

UNIT	FUSE SIZE	UNIT	FUSE SIZE
Accessories.....	25 Amp.	Horn.....	25 Amp.
Cruise Control (Except Fleetwood Seventy-Five)		Power Windows.....	40 Amp. (CB)
Rear Window De-Fogger		On cars equipped with power windows and/or power seats, and on convertible styles, the 25 Amp. horn fuse is replaced by a 40 Amp. Circuit Breaker	
Window Control Relay			
Air Conditioner and Heater	25 Amp.	Instrument and Back-Up... 9 Amp.	
Antenna.....	14 Amp.	Back-Up Lights	
Body Feed.....	25 Amp.	Tell-Tale Lights and Gauges	
Cigar Lighter		Radio.....	7½ Amp.
Clock		Tail and Stop.....	25 Amp.
Courtesy Lights		Ash Tray Lights	
Glove Box Light		Cornering Lights	
*Map Light		Ignition Switch Light	
*Cruise Control.....	6 Amp.	Instrument Panel Lights	
*Generator Indicator.....	6 Amp.	Stop Lights	
Guide-Matic Amplifier.....	4 Amp.	Tail Lights	
Headlights and Parking		Twilight Sentinel	
Lights.....	15 Amp. (CB)	Turn Signal.....	14 Amp.
(Integral with Headlight Switch)		Windshield Wipers.....	25 Amp.

*Fleetwood Seventy-Five sedan and limousine only
Amp.—Ampere (CB)—Circuit Breaker

BULBS

LOCATION	BULB No.	LOCATION	BULB No.
Ash Tray—Front.....	1445	Headlight Switch.....	1895
Back-Up Light.....	1156	Heater and Vent or A/C Control.....	1895
Clock—Instrument Panel.....	1895	High Beam Indicator.....	1445
Cornering Light—Front Fender.....	1195	Ignition Lock.....	1895
Courtesy Lights:		License Plate Light.....	67
Rear Quarter.....	90	*Map and Courtesy.....	212
*Rear Quarter.....	212	Oil Pressure Indicator.....	1895
Console.....	212	Park and Turn Signal.....	1157A
Instrument Panel.....	212	Radio Dial.....	1895
Rear Door.....	212	Radio—AM/FM Indicators.....	53X
*Rear Door.....	90	*Radio—Rear Control Indicator.....	53X
Rear Quarter Armrest/Top Well.....	212	Speedometer.....	1895
Cruise Control Dial.....	1445	Stop and Signal (Bumper).....	1157
Cruise Control (Lock-In Indicator).....	1445	*Stop, Signal and Tail (Fender).....	1157
*Dome Light.....	1004	Temperature Gauge.....	1895
*Dome Light (Chauffeur).....	90	*Transmission Shift Indicator.....	1195
Fuel Gauge.....	1895	Trunk Compartment.....	1003
*Fuel and Temperature Gauge.....	1895	Trunk Lid Indicator.....	1895
Generator Indicator.....	1895	Turn Signal Indicator.....	1445
Glove Compartment and Console.....	1895	Warning Light:	
Headlight:		Front Door.....	212
Lower.....	L4001	Rear Door.....	212
Upper.....	L4002	Windshield Wiper Switch.....	1895
Headlight:			
*Inner.....	4001		
*Outer.....	4002		

* Fleetwood Seventy-Five sedan and limousine only

INDEX

	Page		Page
Air Conditioner	33	Courtesy Lights	11, 29
Ash Receivers and Lighters	11, 31	Crankcase Ventilator	39
Authorized Cadillac Service	36	Cruise Control	19, 31
Back-up Lights	11	De-Fogger, Rear Window	18
Brake Fluid	43	Engine Cooling	41
Brakes	7, 49	Engine Specifications	50
Bulbs	52	Fabric Roof Cover, Cleaning	48
Carbon Monoxide	49	Fleetwood Seventy-Five	28
Carburetor Air Cleaner and Filter	43	Flooded Engine	3
Chrome, Cleaning	47	Fluid Capacities	50
Clock, Electric	11, 34	Fluids and Lubricants	43
Comfort Control	16	Foreign Countries, Operation In	38
Controlled Differential	6, 49	Fuel	37
Convertible Top Operation	27	Fuel Filter	43
Cooling System Protection	41	Fuel Gauge	4
Cornering Lights	12	Fuses	51

INDEX (cont'd)

	Page		Page
Gasoline Tank	39	Light Bulbs	52
Generator Indicator Light	4	Lights	9, 48
Glass, Cleaning	47	Locks, Door	25
Guide-Matic Power Headlight Control	20	Luggage Compartment	26
Headlight Control	9	Manufacturer's Warranty	36
Headlight Dimmer Switch	9	Map Light	29
Headlight High-Beam Indicator	11	Mirrors	13
Heater Controls, Rear	32	Oil, Engine	39, 40
Heater Operation	14	Oil Filter	43
Hoists	44	Oil Pressure Indicator Light	4
Hood Latch	25, 34	Operation in Foreign Countries	38
Ignition Switch	3	Owner Protection Plan	37
Instrument Panel and Controls	9, 10, 11, 30	Owner Responsibility	37
Jack, Use Of	35, 44	Polishing and Waxing	47
Keys	2	Power Steering Fluid	43
Leather, Cleaning	47	Power Windows	24
Level Control, Automatic	26	Preventive Maintenance	42

INDEX (cont'd)

	Page		Page
Protect-O-Plate	37	Tire Rotation	45
Radio Controls, Rear	33	Towing	6
Radios, AM and AM-FM	21	Transmission Fluid	43
Seat Belts	23	Trunk Lock, Power	26
Seat Controls, Front	23	Turbo Hydra-matic Transmission	5, 49
Seats	23	Turn Signal	12
Service, Cadillac	37	Twilight Sentinel	20, 31
Special Notes	48, 49	Undercoating	46
Specifications	49	Upholstery and Carpets, Cleaning	48
Speedometer	4	Vehicle Identification Number	49
Starting the Engine	3	Ventilation	14
Steering	8	Warranty	36
Steering Wheel, Tilt and Telescoping	18	Wheel Changing Instructions	35, 44
Storage, Car	48	White Sidewall Tires, Cleaning	48
Suspension	43	Window Lock Switch	24
Temperature Indicator	4	Windows, Power	24, 29
Tire Pressures	46	Windshield Washer Solution	42
Tires	45	Windshield Wipers and Washers	9

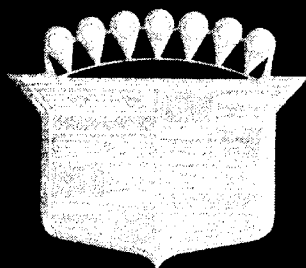

AMA Specifications – Passenger Car

The information contained herein is prepared, distributed by, and is solely the responsibility of the automobile manufacturing company to whose products it relates. Questions concerning these specifications should be directed to the manufacturer whose address is shown below. This uniform specification form was developed by the automobile manufacturing companies under the auspices of the Automobile Manufacturers Association.

MANUFACTURER CADILLAC MOTOR CAR DIVISION	CAR NAME CADILLAC	
MAILING ADDRESS 2860 CLARK AVENUE DETROIT, MICHIGAN	MODEL YEAR 1965	ISSUED: 10-5-64 REVISED (e)

NOTES:

1. The Specifications herein are those in effect at date of compilation and are subject to change without notice by the manufacturer.
2. **UNLESS OTHERWISE INDICATED:**
 - a. Specifications apply to standard models without optional equipment. Significant deviations are noted.
 - b. Nominal design dimensions are used throughout these specifications.

TABLE OF CONTENTS

General Specifications 1	Drive Units 15	Rear Suspension 21	Weights 23
Engine - Mechanical 2	Brakes 18	Station Wagon 1a	Index 24
Electrical 10	Front Suspension & Steering . . 19		

BODY—TYPES AND STYLE NAMES—

Body type, number of passenger & style names; use manufacturer's code for series & body style.

<u>DESCRIPTION</u>	<u>NO. PASS.</u>	<u>STYLE NUMBER</u>	<u>VEHICLE IDENTIFICATION NO.</u>
Fleetwood Sixty Special Sedan (Fleetwood Brougham Option)	6	68069	M5100001
Calais Hardtop Sedan	6	68239	N5100001
Calais Coupe	6	68257	G5100001
Calais Sedan	6	68269	K5100001
Hardtop Sedan de Ville	6	68339	B5100001
Coupe de Ville	6	68357	J5100001
De Ville Convertible	6	68367	F5100001
Sedan de Ville	6	68369	L5100001
Fleetwood Eldorado Convertible	6	68467	E5100001
Fleetwood Seventy-Five Sedan	9	69723	R5100001
Fleetwood Seventy-Five Limousine	9	69733	S5100001

AMA Specifications — Passenger Car

MAKE OF CAR CADILLAC MODEL YEAR 1965 DATE ISSUED 10-5-64 REVISED (a)

GENERAL SPECIFICATIONS

(All dimensions in inches unless otherwise indicated)

MODEL	Additional Information Page No.	680 69	682 57	682 39	682 69	683 57	683 67	683 39	683 69	684 67	697 23-33	
Wheelbase (L101)	23	133		129.5						149.8		
Tread	Front (W101)	22	62.5						61			
	Rear (W102)	22	62.5						61			
Maximum Overall Dimensions	Length (L103)	23	227.5		224						243.8	
	Width (W103)	22	79.9						59.0			
	Height (H101)	24	55.9	54.6	54.5	55.6	54.6	54.5	55.6	54.6	59.0	
Transmission (Specify trade name - opt., not available)	Manual	15	None									
	Overdrive	16	None									
	Automatic	16	Turbo-Hydramatic									
Axle ratio	Manual	17	None									
	Overdrive	17	None									
	Automatic	17	* 2.94:1						** 3.36:1 (69723-33)			
Tire size	18	8.00 X 15						8.20 X 15 (69723-				
Engine	Type, no. cyl., valve arr.	2	O.V. - V-8 - 90°									
	Fuel system (Carb., other)	8	Carb.									
	Bore and stroke	2	4.130 X 4.00									
	Piston displ., cu.in.	2	429									
	Std. compression ratio	2	10.5:1									
	Max. bhp at engine rpm	2	340 @ 4600									
	Max. torque at rpm	2	480 @ 3000									

* 3.21 opt.-std. on Air Conditioning
 ** 3.77 opt.

MAKE OF CAR CADILLAC MODEL YEAR 1965 DATE ISSUED 10-5-64 REVISED (e)

GENERAL SPECIFICATIONS — DIMENSIONS

(All dimensions in inches unless otherwise indicated)
(Supplemental data available on request)

MODEL	Ref. No.	680	682	682	682	683	683	683	683	684	697
		69	57	39	69	57	67	39	69	67	23-33

FRONT COMPARTMENT

Shoulder room	W3	61.9	62.0	61.8	62.0	61.8	62.1	60.4			
Max. eff. leg room - accelerator	L34	41.1	41.0	41.1	41.0	41.1	41.0	40.1			
Effective head room	H61	39.5	38.4	38.5	39.5	38.4	38.6	38.5	39.5	39.1	40.6
H Point to Heel point	H30				8.5					8.0	6.4
Upper body opening to ground	H50	51.0	49.4	50.3	49.4	50.3	50.5	54.8			

REAR COMPARTMENT

Shoulder room	W4	60.8	60.5	60.9	60.5	52.5	60.9	52.5	58.8		
H Point couple distance	L50	43.14	36.66	36.63	39.34	37.26	36.66	37.23	39.66	36.71	62.47
Minimum effective leg room	L51	39.6	38.2	38.8	40.9	38.9	38.2	39.5	41.0	37.6	41.3
Effective head room	H63	38.2	37.6	38.4	37.5	38.4	37.5	38.8			

STATION WAGON—THIRD SEAT

Shoulder room	W85		None
Effective leg room	L86		None
Effective head room	H86		None

LUGGAGE COMPARTMENT

Usable luggage capacity (See instr.)	V1	17.134	13.462	17.134	13.462	16.158
Liftover height	H195		N/A			
Position of spare tire storage			Horizontal			
Method of holding lid open			Spring			

STATION WAGON—CARGO SPACE

Minimum distance between wheel houses at floor level	W201	None
Rear end opening width at belt	W204	↓
Floor length from back of front seat at floor level to inside of closed tail gate	L202	
Minimum horizontal distance from top rear of front seat back to inside of tail gate at belt	L204	
Maximum height - floor covering to headlining at centerline of rear axle	H201	
Maximum height of rear opening - tail and lift gates open	H202	
Cargo volume index (cu.ft.) $\frac{W4 \times L204 \times H201}{1728}$	V2	

AMA Specifications—Passenger Car

MAKE OF CAR CADILLAC MODEL YEAR 1965 DATE ISSUED 10-5-64 REVISED (e)

MODEL _____

ENGINE—GENERAL

Type, no. cyls., valve arr.		90° - V-8 - O.V.
Bore and stroke (nominal)		4.130 X 4.00
Piston displacement, c.u. in.		429
Bore spacing (C/L to C/L)		4.562
No. system (front to rear)	L. Bank	1-3-5-7
	R. Bank	2-4-6-8
Firing order		1-8-7-2-6-5-4-3
Compras. ratio (nominal)		10.5:1
Cylinder Head Material		Cast Iron
Cylinder Block Material		Cast Iron
Cylinder Sleeve—Wet, dry, none		None
Number of mounting points	Front	2
	Rear	1
Engine installation angle		55° 55' 41"
Taxable horsepower	Dia. ² x No. Cyl. 2.5	54.6
Published max. bhp* @ eng. RPM		340 @ 4600
Published max. torque* (lb. ft. @ RPM)		480 @ 3000
Recommended fuel regular - premium		Prem.
Idle speed (spec. neutral or drive)	Manual	N.A.
	Automatic	* 480 Drive

ENGINE—PISTONS

Material		Alum. Alloy	
Description and finish		Double T Slot Cam Ground Contoured Top-Stannate Coat	
Weight (piston only) oz.		20.0	
Clearance (limits)	Top land	.033 - .038	
	Skirt	Top	.0008 - .0012
		Bottom	.000
Ring groove depth	No. 1 ring	.215	
	No. 2 ring	.215	
	No. 3 ring	.177	
	No. 4 ring	None	

*Max. bhp (brake horsepower) and max. torque corrected to 60° F and 29.92 in. Hg atmospheric pressure.

* A/C Car - System On

AMA Specifications – Passenger Car

MAKE OF CAR CADILLAC MODEL YEAR 1965 DATE ISSUED 10-5-64 REVISED (e)

POWER TEAMS

(Indicate whether standard or optional)

MODEL AVAILABILITY	ENGINE					TRANSMISSION	AXLE RATIO (Std. first)
	Displ. cu. in.	Carburetor	Compr. Ratio	BHP @ RPM	Torque @ RPM		
	See Engine Sheet - Page 2						

AMA Specifications – Passenger Car

MAKE OF CAR CADILLAC MODEL YEAR 1965 DATE ISSUED 10-5-64 REVISED (a)

MODEL _____

ENGINE—RINGS

Function (top to bottom)	No. 1, oil or comp.		Comp.
	No. 2, oil or comp.		Comp.
	No. 3, oil or comp.		Oil
	No. 4, oil or comp.		None
Compression	Description - material, type, coating, etc.	#1-Molybdenum Filled Cast Iron #2-Phosphate Coated Cast Iron	
	Width	.0625	
	Gap	.013 - .030	
Oil	Description - material, type, coating, etc.	Multi-Piece Steel Chrome Plated - Notched I.D. Rail	
	Width	.125	
	Gap	.015 - .061	
Expanders		Yes	

ENGINE—PISTON PINS

Material			1045
Length			3.090
Diameter			.9994 - .9997
Type	Locked in rod, in piston, floating, etc.		Locked in Rod
	Bushings	In rod or piston	None
		Material	None
Clearance	In piston	.00005 - .00015	
	In rod	Press Fit	
Direction & amount offset in piston	.062 Toward Max. Thrust Side		

ENGINE—CONNECTING RODS

Material			1041 Steel
Weight (oz.)			19.36
Length (center to center)			6.50
Bearing	Material & Type		M-400 Alum.
	Overall length		.755 - .880
	Clearance (limits)		.0005 - .0021
	End play		.008 - .014 (Total Two Rods)

AMA Specifications—Passenger Car

MAKE OF CAR CADILLAC MODEL YEAR 1965 DATE ISSUED 10-5-64 REVISED (e)

MODEL _____

ENGINE—CRANKSHAFT

Material		Pearlitic Malleable Iron	
Vibration damper type		Rubber Absorption	
End thrust taken by bearing (No.)		#3 Center Main	
Crankshaft end play		.001 - .007	
Main bearing	Material & type	M400 Alum. - M100 Babbitt	
	Clearance		
	Journal dia. and bearing overall length	No. 1	3.00
		No. 2	3.00
		No. 3	3.00
		No. 4	3.00
		No. 5	3.00
No. 6		None	
No. 7		None	
Dir. & amt. cyl. offset		See Piston	
Crankpin journal diameter		2.25	

ENGINE—CAMSHAFT

Location		Center of V	
Material			
Bearings	Material	GM120M Cast Iron	
	Number	Steel Backed Babbitt 5	
Type of Drive	Gear or chain	Silent Chain	
	Crankshaft gear or sprocket material	Sintered Iron GM3884M	
	Camshaft gear or sprocket material	Die Cast Alum. -Nylon Gear	
	Timing chain	No. of links	46
		Width	.875
Pitch		.500	

ENGINE—VALVE SYSTEM

Hydraulic lifters (Std, opt, NA)		Std.
Valve rotator, type (intake, exhaust)		None
Rocker ratio		1.65:1
Operating tappet clearance (indicate hot or cold)	Intake	Auto.
	Exhaust	Auto.
Timing marks on flywheel, damper, other		Crankshaft Balancer

(Continued)

AMA Specifications—Passenger Car

MAKE OF CAR CADILLAC MODEL YEAR 1965 DATE ISSUED 10-5-64 REVISED (*)

MODEL _____

ENGINE—VALVE SYSTEM (cont.)

Timing	Intake	Opens (°BTC)	34	
		Closes (°ABC)	102	
		Duration - deg.	290	
	Exhaust	Opens (°BBC)	89	
		Closes (°ATC)	63	
		Duration - deg.	332	
Valve opening overlap		97		
Intake	Material		1041 Alum. Steel	
	Overall length		4.794	
	Actual overall head dia.		1.875	
	Angle of seat & face		Seat in Head 45 - Valve Face 44	
	Seat insert material		None	
	Stem diameter		.3415 - .3425	
	Stem to guide clearance		.0005 - .0025	
	Lift (@ zero lash)		.427	
	Outer spring press. and length	Valve closed (lb. @ in.)	60-65 @ 1.946"	
		Valve open (lb. @ in.)	155-165 @ 1.496	
	Inner spring press. and length	Valve closed (lb. @ in.)	None	
		Valve open (lb. @ in.)	None	
	Exhaust	Material		21-4N
		Overall length		4.815
Actual overall head dia.		1.50		
Angle of seat & face		Seat 45 - Face 44		
Seat insert material		None		
Stem diameter		.3415 - .3420		
Stem to guide clearance		.0010 - .0025		
Lift (@ zero lash)		466		
Outer spring press. and length		Valve closed (lb. @ in.)	60 - 65 @ 1.946	
		Valve open (lb. @ in.)	155 - 165 @ 1.496	
Inner spring press. and length	Valve closed (lb. @ in.)	None		
	Valve open (lb. @ in.)	None		

ENGINE—LUBRICATION SYSTEM

Type of lubrication (splash, pressure, nozzle)	Main bearings	Press.
	Connecting rods	Press.
	Piston pins	Splash
	Camshaft bearings	Press.
	Tappets	Press.
	Timing gear or chain	Metered Centrifugal Flow
	Cylinder walls	Intermediate Jet

(Continued)

AMA Specifications – Passenger Car

MAKE OF CAR CADILLAC MODEL YEAR 1965 DATE ISSUED 10-5-64 REVISED (e)

MODEL _____

ENGINE—LUBRICATION SYSTEM (cont.)

Oil pump type	Spur Gear
Normal oil pressure (lb. @ engine rpm)	30 - 35 @ 30 MPH
Oil pressure sending unit (elect. or mech.)	Electric
Type oil intake (floating, stationary)	Stationary
Oil filter system (full flow, partial, other)	Full Flow
Filter replacement (element, complete)	Element
Capacity of crankcase, less filter-refill (qt.)	4 Plus 1 for Filter
Oil grade recommended (SAE viscosity and temperature range)	+ 32 ^o F SAE 20W - 10W30 + 32-0 SAE 10W - 10W30 Below 0 SAE 5W - 5W20
Engine Service Requirement (MM, MS, etc.)	MS - GM 4745M

ENGINE—EXHAUST SYSTEM

Type (single, single with cross-over, dual, other)	Single With Cross Over
Muffler No. & type (reverse flow, straight thru, separate resonator)	Co-Axial Resonator 75 Series-Reverse Flow Muff. Exhaust System Straight Thru Resonator
Exhaust pipe dia. (O.D. Branch wall thickness)	Exhaust 2.00 - 2.50
Exhaust pipe dia. (O.D. Main wall thickness)	Intermediate 2.24
Tail pipe diameter (O.D. & wall thickness)	2.25 - .0598

ENGINE—CRANKCASE VENTILATION SYSTEM

Type (ventilates to atmos., induction system, other)	Standard	Induction System
	Optional	None
Control unit	Make and model	A/C
	Location	Below Carburetor
	Energy source (manifold vacuum, carburetor air stream, other)	Manifold Vacuum
	Control method (variable orifice, fixed orifice, other)	Spring Loaded Valve and Fixed Orifice
Complete system	Discharges (to intake manifold, carb. air intake, air cleaner intake, other)	Intake Manifold
	Air Inlet (breather cap, carburetor air cleaner, other)	Breather Cap
	Flame arrester (screen, check valve, other)	Check Valve

AMA Specifications— Passenger Car

MAKE OF CAR CADILLAC MODEL YEAR 1965 DATE ISSUED 10-5-64 REVISED (e)

MODEL ALL

ENGINE—FUEL SYSTEM

(See Supplement to Page 8 for Details of Fuel Injection, Supercharger, etc. if used)

Induction type: Carburetor, fuel injection, supercharger.		Carburetor
Fuel Tank	Capacity (gals.)	26
	Filler location	Rear of License Plate
Fuel Pump	Type (elec. or mech.)	Mechanical
	Locations	Lower Left Side - Frt. of Eng.
	Pressure range	5.25 - 6.50 @ 1800 RPM
Vacuum booster (std., optional, none)		None
Fuel Filter	Type	AC
	Locations	Top Center - Frt. of Engine - One in Fuel Tank
Carburetor	Choke type	Integral
	Intake manifold heat control (exhaust or water)	Exhaust
	Air clnr. type	Dry Pack Single Inlet
	Standard Optional	-

CARBURETOR SUPPLEMENTARY INFORMATION

Model Usage	Engine Displ.	Transmission	Carburetors		No. Used and Type	Barrel Size
			Make	Model		
All	429	Automatic	Carter	AFB 3903-S	One 4 BBL Downdraft	Pri. 1.4375
						Sec. 1.6875
All	429	Automatic	Rochester	7025030	"	"
			Carter	Air Cond. AFB 3904-S	"	"
			Rochester	Air Cond. 7025031	"	"

AMA Specifications – Passenger Car

MAKE OF CAR CADILLAC MODEL YEAR 1965 DATE ISSUED 10-5-64 REVISED (*)

MODEL ALL

ENGINE—COOLING SYSTEM

Type system (pressure, pressure vented, atmospheric, other)		Pressure	
Radiator cap relief valve pressure		13.5 - 16.5	
Circulation thermostat	Type (choke, bypass)	Choke	
	Starts to open at (°F)	172° - 177°	
Water pump	Type (centrifugal, other)	Centrifugal Dual Outlet	
	GPM @ 1000 pump rpm	19	
	Number of pumps	One	
	Drive (V-belt, other)	V Belt	
Bearing type		Double Row Ball Bearing	
By-pass recirculation type (internal, external)		Internal	
Radiator core type (cellular, tube and fin, other)		Tube & Center	
Cooling system capacity	With heater (qt.)	17.2	19.7 (75)
	Without heater (qt.)	-	
	Opt. equipment-specify (qt.)	18.2 With Air Cond.	20.7 (75)
Water jackets full length of cylinder (yes, no)		Yes	
Water all around cylinder (yes, no)		Yes	
Radiator hose	Lower	Number and type (molded, straight)	(1) Molded
		Inside diameter	1.75
	Upper	Number and type (molded, straight)	(1) Molded
		Inside diameter	1.50
	By-pass	Number and type (molded, straight)	None
		Inside diameter	None
Fan	Number of blades & Spacing		7 @ 54° - 50° - 45° - 40° - 48° - 64° - 59°
	Diameter		18"
	Ratio-fan to crankshaft rev.		1.1:1
	Fan cutout type		None
	Bearing type		Ball
*Drive belts (Indicate belt used by letter)	Fan		None
	Generator	Fan - W/P	38.08
	Water Pump		53.10 (75)
	Power Steering		49.94
Air Conditioning		50.24 A/C	50.62 (75)
		56.0	

* Drive Belt Dimensions	See Above	
Angle of V	38 Degrees	
Nominal length (SAE)	See Above	
Width	.380	.460 A/C

AMA Specifications – Passenger Car

MAKE OF CAR CADILLAC MODEL YEAR 1965 DATE ISSUED 10-5-64 REVISED (*)

MODEL _____

ELECTRICAL—SUPPLY SYSTEM

Battery	Make and Model	Delco Remy		
	Voltage Rtg. & Total Plates	12 Volt - 13 Plate		
	SAE Designation & Amp Hr. Rtg	73 Amp. Hrs. @ 20 Hr. Rate		
	Location	Right Frt. Side - Under Hood		
	Terminal grounded	Negative		
Generator	Make	Delco Remy		
	Model	1100691		
	Type	42	1100692 (75 & A/C)	
	Ratio—Gen. to Cr/s rev.	2.78:1	55 (75 & A/C)	
	Gen. cut-in (hot)—engine rpm	Charge @ Idle		
Regulator	Make	Delco Remy		
	Model	1111032		
	Type	Double Contact		
	Cutout relay	Closing voltage @ generator rpm	None	
		Reverse current to open	None	
	Regulated	Voltage	13.5 - 14.4 @ 120 Degrees	
		Current	None	
	Voltage test conditions	Temperature	120 Degrees	
		Load	10 Amps	
		Other	-	

ELECTRICAL—STARTING SYSTEM

Starting motor	Make	Delco Remy		
	Model	1107367	1107368 (75)	
	Rotation (drive end view)	Clockwise		
	Engine cranking speed	150-200 RPM		
	Test conditions	-		
	Lock test	Amps	410-480	
		Volts	3.0	
		Torque (lb. ft.)	N/A	
	No load test	Amps	70-99	
		Volts	10.6	
RPM (min.)		7800-12000		
Motor control	Switch (solenoid, manual)	Solenoid		
	Starting procedure	<p>Cold Start - Depress Acc. to Floor, Remove foot, Turn Ign. Key full Right to Start</p> <p>Warm Start - Depress Acc. Halfway Hold Until Engine Starts</p>		

(Continued)

AMA Specifications – Passenger Car

MAKE OF CAR CADILLAC MODEL YEAR 1965 DATE ISSUED 10-5-64 REVISED ^(*)

MODEL _____

ELECTRICAL—STARTING SYSTEM (cont.)

Motor Drive	Engagement type		Spiral Spline & Over-Running Clutch	
	Pinion meshes (front, rear)		Front	
	Number of teeth	Pinion		9
		Flywheel		166
	Flywheel tooth face width		.500	

ELECTRICAL—IGNITION SYSTEM

Coil	Make		Delco Remy	
	Model		1115132	
	Amps	Engine stopped		2.4
		Engine idling		1.25
Distributor	Make		Delco Remy	
	Model		1111032	
	Cent'fgal adv. in crankshaft degrees @ engine rpm (nominal)	Start (rpm)		0° - 1.5° @ 400 RPM
		Intermediate points deg. @ rpm		4.5° - 6.25° @ 1200 RPM
		Max deg. @ rpm		7° - 9° @ 2000 RPM
	Vacuum adv. in crankshaft degrees @ in. Hg. (nominal)	Start (in Hg)		7.5 - 9.5
		Intermediate points, deg @ in Hg		3.25° - 5.75° @ 12" 8.50° - 12.00 @ 16"
		Max. deg. in. Hg.		10.50° - 12.00° @ 20"
		Breaker gap (in.)		.016
		Cam angle (deg.)		28° - 32°
	Breaker arm tension (oz.)		19 - 23 oz.	
Timing	Crankshaft deg. @ rpm.		5° BTDC	
	Mark location		Crankshaft Bal.	
	Cylinder numbering system (see page 2)			1-3-5-7 Left Bank 2-4-6-8 Right Bank
		Firing order (see page 2)		1-8-7-2-6-5-4-3
Spark Plug	Make and model		AC - 44	
	Thread (mm)		14	
	Tightening torque (lb. ft.)		25	
	Gap		.035	
	Conductor type		Resistant Core	
Cable	Insulation type		Neoprene	
	Spark plug protector		Neoprene	

ELECTRICAL—SUPPRESSION

Locations & type	Packard Electric - Dist. Res. Wire .3 MFD on Coil - Feed Term .5 MFD on Gen. Reg. - Feed Term Two ground straps - Rear of Cylinder head Two ground straps - Upper Control Arms
------------------	--

AMA Specifications – Passenger Car

MAKE OF CAR CADILLAC MODEL YEAR 1965 DATE ISSUED 10-5-64 REVISED (*)

MODEL _____

ELECTRICAL—INSTRUMENTS AND SWITCHES

Speed-ometer	Make	A.C.
	Trip odometer (yes, no)	Yes
Charge indicator—type		Tell-Tale
Temperature indicator—type		Gauge
Oil pressure indicator—type		Tell-Tale
Fuel indicator—type		Gauge
Other		Trunk Warning Light - Tell-Tale
Ignition switch	Identify positions in order and circuits controlled	Vertical - Ignition Off 1st Position Clockwise - All Circuits On 2nd Position Clockwise - Ign. & Starter 1st Position Counter Clockwise - Acc. Only
	Provision for illumination	Yes
	Location	Upper - Center of Instrument Panel
Main light-switch	Identify positions and lamps controlled	1st Position - Park - Instruments & Tail 2nd Position - Full Out Headlamps - Instrument & Rotate Knob - Full Left - Operates Interior Lites Rotate Knob - Right - Rheostat Control Intensity of Panel Lites.
Other light switches	Locations and lamps controlled	Glove Box - Console - Air Cond. - Heater, Turn Indicator & Signal - Trunk Switch Controls Cornering Lites when Ign. and Lite Switch are on.
Other switches	Locations and devices controlled	Door Jam Switches for Interior Lites. Switches on Front Seat Backs for Rear Compartment Lites. Interior Lites also controlled by Headlamp Switch.
Windshield wiper	Make	Delco
	Type	Electric
	Vacuum booster provision	-
	Washer provision	Yes
Horn	Type	Solenoid Vibrating Diaphragm
	Number used	3
	Amp draw (each)	4.5 - 5.5

AMA Specifications – Passenger Car

MAKE OF CAR CADILLAC MODEL YEAR 1965 DATE ISSUED 10-5-64 REVISED (*)

MODEL _____

ELECTRICAL—LAMP BULBS

Give quantity used and trade number, e.g., Headlamp 2-5400 S, dual headlight 2-4001, 2-4002.

Headlamps & arrangement	Dual Vertical	Dual Horizontal (75)
Headlamp beam indicator	1-1445	
Parking & Dir.	2-1157A	
Tail -Stop-Sig.	2-1157A	
Stop Tail-Signal	2-1157A	
Direction signal	Front	See Parking Lite
	Rear	See Stoplite
	Indicator	2-1445
License Plate	2-67	
Oil pressure indicator	1-1895	
Charge indicator	1-1895	
Instrument	4-1895	
Clock	2-1895	
Radio	Opt. 1-1895	

Indicate also whether the following lamp assemblies are standard equipment, optional, or NA.

Ignition lock	Std.	1-1895	
Back up	Std.	2-1156	
Dome	Std.	1-1004	
Glove compartment	Std.	1-1895	Chauffer 1-90
Prkg. brake signal		N/A	
Luggage compartment	Std.	1-89	
Underhood		N/A	
Courtesy	Std.	2 - 90 & 2 - 212	
Map			(75) 1-212

Ash Tray	3-1445	
Cornering Lamp	2-1195	
Rear Quarter Lamp	2-90 (68-63-62)	
Rear Quarter Lamp	2-212	
Instrument Panel	2-212	
Fuel & Temperature	2-1895	
Heater & Vent Pnl.	1-1895	4-1895 (75)
Console	2-57	
Radio Rear Control	1-53X - Opt.	
Trunk Tell-Tale	1-1895-Opt.	
Warning Lmp. F. Door	2-212	
Warning Lmp. R. Door	2-212	

AMA Specifications – Passenger Car

MAKE OF CAR CADILLAC MODEL YEAR 1965 DATE ISSUED 10-5-64 REVISED (a)

MODEL _____

ELECTRICAL—FUSE & CIRCUIT BREAKER DATA

Use trade number of fuse, e.g., SFE-10. Indicate circuit breaker by ampere capacity suffixed by letters "C.B.", e.g., 30 C.B. Where fuse or circuit breaker protects multiple circuits indicate first use by a letter and repeat the same letter for all units protected by the same fuse or circuit breaker, e.g., Parking lamp SFE-10 (a), Direction indicator same as (a).

Headlamp	15 Amp (CB)	Power Seats & Windows	40 Amp (CB)
Headlamp beam indicator	15 Amp (CB)	Hydro-Elect. Conv. Top	40 Amp
Parking lamp	15 Amp (CB)	Cruise Control	25 Amp & Amp Sw.
Tail lamp	25 Amp	Horns	25 Amp
Stop lamp	25 Amp	Guide-Matic	4 Amp
Direction indicator	14 Amp	Cornering Lites	25 Amp
License plate lamp	25 Amp		
Instrument lamp	9 Amp		
Ignition lamp	25 Amp		
Back up lamp	9 Amp		
Dome lamp	N/A		
Clock	25 Amp		
Clock lamp	15 Amp (CB)		
Radio	7 1/2 Amp		
Glove compartment lamp	25 Amp		
Power Trunk T.T.	9 Amp		
A/C & Heater	25 Amp		
Antenna	14 Amp		
1/S Wiper	25 Amp		
Body Feed	25 Amp		
Ash Tray	25 Amp		
Instrument Lites	25 Amp		
Cigar Lighter	25 Amp		
Generator T.T.	6 Amp		

ELECTRICAL—LOCATION OF OUTSIDE LAMPS All

				Lower	Upper
Height above ground to center of bulb	Tail	Lowest	22.80 (60 Special-Calais-DeVille)	22.90 (75)	
		Highest	-	33.47 (75)	
	Stop		22.86	22.90 (75)	33.47
	Backup		22.86	22.90 (75)	
Normal Load	License, rear		22.86	22.90 (75)	
	Directional	Front	16.26	23.19 & Cornering (75)	
		Rear	22.86	22.90 (75)	33.47
	Headlamp	Inside	Upper 30.11	29.42 (75)	
Outside*		Lower 23.66 Cornering 23.66	29.42 (75)		
Distance from C/L of car to center of bulb	Tail	Inside	-		
		Outside	34.75	35.00 (75)	
	Stop		34.75	35.00 (75)	
	Backup		34.75	35.00 (75)	
	License, rear			C/L	
	Directional	Front	29.16	31.75 (75)	
		Rear	34.75	35.00 (75)	
	Headlamp	Inside	Upper 34.90	28.60 (75)	
Outside*		Lower 34.90	31.75 (75)		

* If single headlamps are used enter here.

AMA Specifications – Passenger Car

MAKE OF CAR CADILLAC MODEL YEAR 1965 DATE ISSUED 10-5-64 REVISION (*)

MODEL _____

DRIVE UNITS—CLUTCH (Manual Transmission)

Make & type	N/A	
Type pressure plate springs		
Effective plate pressure (lb.)		
No. of clutch driven discs		
Clutch facing	Material	
	Outside & inside dia.	
	Total eff. area (sq.in.)	
	Thickness	
	Engagement cushioning method	
Release bearing	Type & method of lubrication	
Torsional damping	Methods: springs, friction material	

DRIVE UNITS—TRANSMISSIONS

Manual (std. or opt.)	
Manual with overdrive (std. or opt.)	
Automatic (std. or opt.)	Automatic Std.

DRIVE UNITS—MANUAL TRANSMISSION

Number of forward speeds	N/A		
Transmission ratios	In first		
	In second		
	In third		
	In fourth		
	In reverse		
Synchronous meshing, specify gears			
Shift lever location			
Lubricant	Capacity (pt.)		
	Type recommended		
	SAE viscosity number	Summer	
		Winter	
Extreme cold			

AMA Specifications – Passenger Car

MAKE OF CAR CADILLAC MODEL YEAR 1965 DATE ISSUED 10-5-64 REVISED (*)

MODEL _____

DRIVE UNITS—MANUAL TRANSMISSION WITH OVERDRIVE

For transmission data see manual transmission section

Overdrive	Type (planetary or other)		N/A
	Manual lockout (yes, no)		
	Downshift accelerator control (yes, no)		
	Minimum cut-in speed		
	Gear ratio		
Lubricant	Capacity (pt.) (Overdrive only)		
	Separate filler (yes, no)		
	Type recommended		
	SAE viscosity number	Summer	
Winter			
Ext. cold			

DRIVE UNITS—AUTOMATIC TRANSMISSION

Trade name	Turbo-Hydramatic		
Type describe	Variable Vane Converter with Step Gear Shifts		
Method of Selection (Lever, Push Button or other)	Lever		
Selector Pattern	P-R-N-DD-L		
List gear ratios Selector Pattern and indicate which are used in each selector position	1 - 2.48	2 - 1.48	Plus Converter Multiplication 2.00
	3 - 1.00		
	Reverse - 2.07		
Max. upshift speeds—drive range	74 - 90	67 - 82	(75)
Max. kickdown speeds—drive range	82 - 64	75 - 58	(75)
Torque convertor	Number of elements		3
	Max. ratio at stall		2-1
	Type of cooling (air, water)		Water
Lubricant	Capacity—refill (pt.)		Approx. 3 Qts.
	Type recommended		Fluid Type "A" (Suffix "A")
Special transmission features			

DRIVE UNITS—PROPELLER SHAFT

Number used	1	2 (75)
Type (exposed, torque tube)	Exposed	
Outer diameter x length* x wall thickness	Manual transmission	N.A.
	Overdrive transmission	N.A.
	Automatic transmission Turbo	4.00" X 73.42 X .065 3.50" X 69.92" X .065

*Center to center of universal joints, or to centerline of rear attachment.
 Dia. of Rear Portion of Rear (75) Front 2.25" X 44.55" X .095"
 Shaft 2.75 Wall Thickness .065" * Rear 2.25" X 40.88" X .095"

(Continued)

AMA Specifications – Passenger Car

MAKE OF CAR CADILLAC MODEL YEAR 1965 DATE ISSUED 10-5-64 REVISED ^(*)

MODEL _____

DRIVE UNITS—PROPELLER SHAFT (cont.)

Inter- mediate bearing	Type (plain, anti-friction)		Roller Brg. (75)
	Lubrication (fitting, prepack)		Prepack
Universal joints	Make		Saginaw
	Number used	2 Assy.	3 Assy. (75)
	Type (ball and trunnion, cross, other)	Frt. & Rear - Constant Velocity	Cross (75) Frt. - Center - R
	Bearing	Type (plain, anti-friction)	
Lubric. (fitting, prepack)			Prepack
Drive taken through (torque tube or arms, springs)			Four Link Arm
Torque taken through (torque tube or arms, springs)			Four Link Arm

DRIVE UNITS—REAR AXLE

Description (see instructions)			
Limited Slip differential, type		Hypoid	
Drive Pinion Offset		Cone Clutch	
No. of differential pinions		1.75	
Gear ratios (Std. equip.)	Manual transmission	2	
	Overdrive transmission	None	
	Automatic transmission	None	
Ring gear O.D. (std. ratio)	2.94	3.36 (75)	
Pinion adjustment (shim, other)		*	
Pinion bearing adj. (shim, other)		None	
Wheel bearing type		Collapsible Spacer	
Lubricant	Capacity (pt.)	Ball	
	Type recommended	5	
	SAE vis- cosity number	Summer	Mil-L-2105B (Contr. Diff. Spec. Lub.)
		Winter	90
Extreme cold		90	

REAR AXLE RATIO TOOTH COMBINATIONS

Other Series (See page 3 for axle ratio usage)

75

Axle ratio		2.94	3.21	3.36	3.77
to. of teeth	Pinion	47	45	47	49
	Ring gear	16	14	14	13

* Ring Gear O.D.
9.424

9.422

9.429

AMA Specifications – Passenger Car

MAKE OF CAR CADILLAC MODEL YEAR 1965 DATE ISSUED 10-5-64 REVISED (•)

MODEL _____

DRIVE UNITS—WHEELS

Type & material		Slotted Steel Disc
Rim (size and flange type)	Std.	15 - 6JK
	Opt.	None
Attachment	Type (bolt or stud)	Stud
	Circle diameter	5"
	Number and size	5.50 - 20

DRIVE UNITS—TIRES

Standard (List option below)	Size & ply	8.00 X 15-4 Ply (75)	8.20 X 15 - 6 Ply
	Type - Nylon, etc.	Tyrex	
Rev/mile at 50 mph.		715	713 (75)
Inflation press.(cold)	Front	26	28
	Rear	26	28
Optional tires - size and ply		White Wall 9.00 X 15 714.12 24-24	8.20 X 15 - 6 Ply White

BRAKES—SERVICE

Type (duo-servo, disc, balanced, etc.)		Hydraulic Duo-Servo	Self Adj.
Self adjusting (std., opt., N.A.)		Std.	
Hydraulic system type (single, dual, etc.)		Dual	
Power brake make & type (remote, integral, etc.)		Moraine & Bendix - Direct Hyd. Vacuum	
Effective area (sq. in.)*		203.60	207.50 (75)
Gross lining area (sq. in.)**		233.50	259.60 (75)
Swept drum area (sq. in.)***		377.0	
Percent brake effectiveness—front		59%	
Drum	Diameter	Front	12"
		Rear	12"
	Type and material	Composite Cast Iron Finned	
Wheel cylinder bore	Front	1 3/16	
	Rear	1.00	
Master cylinder bore		1.00	
Available pedal travel		4.28	
Line pressure at 100 lb. pedal load		930 PSI	
Shoe clearance adjustment		.010 - .030	

* Excludes rivet holes, grooves, chamfers, etc.
 ** Includes rivet holes, grooves, chamfers, etc.
 *** Total swept areas for four brakes
 Widest lining contact width for each brake x its drum circumference.

(Continued)

AMA Specifications—Passenger Car

MAKE OF CAR CADILLAC MODEL YEAR 1965 DATE ISSUED 10-5-64 REVISED (e)

MODEL _____

BRAKES—SERVICE (cont.)

Brake lining	Bonded or riveted		Riveted	
	Front Shoe	Material		Molded Asbestos
		Size (length x width x thickness)	Front wheel	11.00 X 2.5 X .26
			Rear wheel	11.00 X 2.5 X .24 11.00 X 2.5 X .26 (75)
		Segments per shoe		1
	Rear Shoe	Material		Molded Asbestos
		Size (length x width x thickness)	Front wheel	12.36 X 2.5 X .28
			Rear wheel	12.36 X 2.5 X .26 12.36 X 2.5 X .28 (75)
Segments per shoe		1		

BRAKES—PARKING

Type of control		Foot Operated - Vacuum Released
Location of control		Left Side Below Inst. Panel
Operates on		Rear Service Brakes.
If separate from service brakes	Type (internal or external)	N/A
	Drum diameter	N/A
	Lining size (length x width x thickness)	N/A

FRAME or UNITIZED CONSTRUCTION

Type and description	Perimeter Frame	Tubular 'X' 75 Series
----------------------	-----------------	-----------------------

SUSPENSION—GENERAL (See Supplemental page 19 for details on Air Suspension)*

Provision for car leveling		Automatic Level Control Std.-60S & Eldorado
Provision for brake dip control		In Front Suspension Design
Provision for acc. squat control		In Rear Suspension Design
Special provisions for car jacking		Bumper Type (75) Scissor Type Rocker Sill
Shock absorber front & rear	Type	Direct Action
	Make	Delco
	Piston dia.	1"
Other special features		Nylon Piston Ring Freon Envelope - Eliminates Aeration of Oil

SUSPENSION—FRONT

Type and description	Independent - Coil
----------------------	--------------------

Air Suspension:
Air spring type
Compressor data
type
make
drive ratio

Normal operating pressures
spring rates
leveling data

(Continued)

AMA Specifications – Passenger Cars

MAKE OF CAR CADILLAC **MODEL YEAR** 1965 **DATE ISSUED** 10-5-64 **REVISED** (0)

MODEL _____

SUSPENSION FRONT (cont.)

Spring	Type	Coil		
	Material	9260		
	Size (coil design height & I.D.; bar length x dia.)	10.09" X 4.00" X 157.70 X .680 (62-63)	10.09 X 4.00 X 165.7 X .69	
	Spring rate (lb. per in.)	325	335 (60)	425 (75)
	Rate at wheel (lb. per in.)	86	89 (61)	120 (75)
	Design load (lb. @ design height)	2600 (62-63)	2700 (60)	2900 (75)
Stabilizer	Type (link, linkless, frameless)	Link		
	Material & bar diameter	1085 Steel .815	1085 Steel .875	

STEERING

Manual (std., opt., NA)		None		
Power (std., opt., NA)		Std.		
Adjustable steering wheel (tilt, swing, other)	Type and description	Tilt & Telescope		
	(std., opt., NA)	Opt.		
Wheel diameter	Manual	-		
	Power	16"		
Tire	Outside front	Wall to wall (l. & r.)	47.9 (60S)	48.9 51 (75)
		Curb to curb (l. & r.)	44.7 (60S)	45.8 48 (75)
	Inside rear	Wall to wall (l. & r.)	26.5 (60S)	27.4
		Curb to curb (l. & r.)	27.1 (60S)	28.0

Outside wheel angle with inside wheel at 20°

Manual	Gear	Type	N.A.			
		Make	"			
		Ratios	Gear	"		
			Overall	"		
	No. wheel turns	"				
Power	Type (coaxial, linkage, etc.)		Inline Hydr. Power			
	Make		Saginaw			
	Gear	Type	Ball Nut Sector			
		Ratios	Gear	17.5:1		
			Overall	18.2:1		
	Pump driven by		Belt			
	Number wheel turns		3.7			
Linkage	Type		Parallel Draglink			
	Location (front or rear of wheels, other)		Rear			
	Drag link (trans. or longtr.)		Trans.			
	Tie rods (one or two)		2			

(Continued)

A.M.A Specifications – Passenger Car

MAKE OF CAR CADILLAC MODEL YEAR 1965 DATE ISSUED 10-5-64 REVISED (e)

MODEL _____

STEERING (cont.)

Steering Axis	Inclination at camber (deg.)		$6^{\circ} @ 0^{\circ}$
	Bearings (type)	Upper	Spherical Joints
		Lower	Spherical Joint
	Thrust	Spherical Joints	
Wheel alignment (range and preferred)	Caster (deg.)		$-1/2$ to $-1 1/2^{\circ}$
	Camber (deg.)		Left Side $+3/8^{\circ}$ to $-1/8^{\circ}$ Right Side $+1/8^{\circ}$ to $-3/8$
	Toe-in (outside tread-inches)		$3/16''$ To $1/4$
Steering spindle & joint type			Spherical
Wheel spindle	Diameter	Inner bearing	1.348 - 1.343
		Outer bearing	.8430 - .8435
	Thread size		$3/4 - 20$
	Bearing type		Tapered Roller

SUSPENSION—REAR

Type and description		4 Link		
Drive and torq. taken through (see page 17)		4 Link Arms		
Spring	Type	Coil		
	Material	9260 Steel		
	Size (length x width, coil design height and I.D.; bar length & dia.)	$9.00'' \times 5.50'' \times 145.9'' \times .590$ $9.17 \times 5.20 \times 149.75 \times 695 (75)$		
	Spring rate (lb. per in.)	115	95 (60) 230 (75)	
	Rate at wheel (lb. per in.)	110	110 (60) 157 (75)	
	Design load (lb. at design height)	1300	1175 (60) 1960 (75)	
	Mounting insulation type		Rubber	
	If leaf	No. of leaves		N/A
		Inserts	Type and size	
			Material	
Shackle (comp. or tens.)				
Stabilizer	Type (link, linkless, frameless)			
	Material			
Track bar type				

AMA Specifications – Passenger Car

MAKE OF CAR	CADILLAC	MODEL YEAR	1965	DATE ISSUED	10-5-64	REVISED (•)	
MODEL	68069	68367 68467	68269 68369	68257 68357	68239 68339		69723

BODY—MISCELLANEOUS INFORMATION

Drs. hinged (front, rear)	Front doors	Front					
	Rear doors	Center	—	Center	—	Center	
Type of finish (lacquer, enamel, other)		Acrylic					
Hood counterbalanced (yes, no)		Yes					
Hood release control (internal, external)		External					
Vehicle (Serial) No. Location		R.H. Side Rail at #1 Crossmember					
Engine No. Location		Rear - Top - E of Crankcase					
Theft protection - type		Ign. Key Start - Door Lock					
Vent window control method (crank, friction pivot)	Front	60 Spec. & 68467 - Power Std. - All others Crank					
	Rear	60 Spec. Power Std.					
Seat cushion type	Front	Zig-Zag Spring - Calais & DeVille - Coil Spring 60 & 75					
	Rear	Zig-Zag Spring - Calais & DeVille - Coil Spring 60 & 75					
	3rd seat	None					
Seat back type	Front	Zig-Zag Spring - Calais & DeVille - Coil Spring 60 & 75					
	Rear	Zig-Zag Spring - Calais & DeVille - Coil Spring 60 & 75					
	3rd seat	None					
Windshield glass type (i.e., single curved - laminated plate)		Compound Curve - Laminated					
Backlight glass type (i.e., compound curved - tempered plate, three piece)		Tempered Plate					
		CC	SC	CC	SC		
Side glass type (i.e., curved - tempered plate)		Vent Window Curved - Laminated				Side Window Curved Tempered	
Side glass exposed surface area		1959.6	1744.2	1865.7	1744.0	1769.2	2378.2
Windshield glass exposed surface area		1532.2	1467.9	1532.2	1467.9		1813.1
Backlight glass exposed surface area		852.8	876.0	1095.0	908.4		500.3
Total glass exposed surface area		4344.6	4088.1	4492.9	4120.3	4145.5	4691.6

BODY—CONVENIENCE EQUIPMENT (Indicate whether standard, optional or NA on each series)

Power windows	Side Windows	Std. on 68069 - All DeVille & 75 - Opt. all others					
	Vent Windows	Std. on 68069 & 68437 Opt. all others					
	Backlight or tailgate	N/A					
Power seats (specify type as well as availability)		2-Way Std. on 60 Spec & All DeVilles & Limo. 6 Way Opt. all Series Exc. Limo. 2-Way N/A on Calais					
Reclining front seat back		N/A					
Front seat headrest		N/A					
Radios (specify type as well as availability)		Delco AM Opt & Delco AM & FM Opt. all Series					
Rear seat speaker		Std. with Radio Opt.					
Power Antenna		Std. with Radio Opt.					
Clock		Std. All Series					
Air Conditioner (specify type and availability)		Opt. Combined Heater & Air Conditioning					

AMA Specifications – Passenger Car

INDEX

SUBJECT	PAGE NO.	SUBJECT	PAGE NO.
Automatic Transmission	1, 16	Linings - Clutch, Brake	15, 19
Axis, Steering	21	Lubrication	6, 7, 15, 16, 17
Axle, Rear	1, 17	Luggage Capacity	1a
Battery	10	Motor, Starting	10
Bearings, Engine	4, 5, 6	Muffler	7
Belts - Fan, Generator, Water Pump	9	Overdrive	16
Body - General Information, types	Title, 1, 22	Piston Pins & Rings	2, 4
Exterior Dimensions	1	Pistons	2
Interior Dimensions	1a	Power Brakes	18
Brakes - Parking, Service, Power	18, 19	Power Steering	20
Camber	21	Power Teams	3
Camshaft	5	Propeller Shaft, Universal Joints	16, 17
Capacities		Pumps - Oil, Fuel	7, 8
Cooling System	9	Water	9
Fuel Tank	8	Radiator, Hoses	9
Lubricants		Ratios - Axle	1, 3, 17
Engine Crankcase	7	Compression	1, 2, 3
Transmission and Overdrive	15, 16	Steering	20
Rear Axle	17	Transmission	15, 16
Carburetor	3, 8	Rear Axle	1, 3, 17
Caster	21	Regulator - Generator	10
Choke, Automatic	8	Rims	18
Circuit Breakers, Fuses	14	Rings, Piston	4
Clutch - Pedal Operated	15	Rods - Connecting	4
Coil, Ignition	11	Shock Absorbers, Front & Rear	19
Connecting Rods	4	Spark Plugs	11
Cooling System	9	Speedometer	12
Crankcase Ventilation	7	Springs - Front & Rear Suspension	20, 21
Crankshaft	5	Valve, Engine	6
Cylinders and Cylinder Head	2	Stabilizer (Sway Bar) - Front & Rear	20, 21
Distributor - Ignition	11	Starting Motor	10
Electrical System	10, 11, 12, 13, 14	Steering	20, 21
Engine		Suppression - Ignition, Radio	11
Bore, Stroke, Displacement, Type	1, 2	Suspension - Front & Rear	19, 20, 21
Compression Ratio	1, 2	Switches	12
Firing Order, Cylinder Numbering	2, 11	Tailpipe	7
General Information, H.P. & Torque	1, 2	Thermostat, Cooling	9
Lubrication	6, 7	Timing, Engine & Valve	5, 6, 11
Power Teams	3	Tires	1, 18
Exhaust System	7	Toe in	21
Equipment Availability	22	Torque Converter	16
Fan, Cooling	9	Torque - Engine, Rated	1, 2, 3
Filters - Engine Oil, Fuel System	7, 8	Transmission - Types	1, 3, 8, 15, 16
Frame	19	Automatic	1, 3, 8, 15, 16
Front Suspension	19, 20	Manual & Overdrive	1, 3, 8, 15, 16
Fuel, Fuel Pump, Fuel System	1, 2, 8	Ratios	15, 16
Fuel Injection	1, 8	Tread	1
Fuses, Circuit Breakers	14	Trunk Luggage Capacity	1a
Generator and Regulator	10	Turning Diameter	20
Glass	22	Unitized Construction	19
Height (Lamps)	14	Universal Joints, Propeller Shaft	16, 17
Headroom - Body	1a	Valves - Intake & Exhaust	5, 6
Heights - Overall	1	Vibration Damper	5
Horns	12	Voltage Regulator	10
Horsepower - Brake	1, 2, 3	Water Pump	9
Ignition System	11	Weights - Shipping, Curb	23
Inflation - Tires	18	Wheel Alignment	21
Instruments	7, 12	Wheelbase	1
Kingpin (Steering Axis)	21	Wheels & Tires	18
Lamp Bulbs	13	Wheel Spindle	21
Lamp Height & Spacing	14	Widths - Car & Body	1
Legroom	1a	Windshield	22
Lengths - Overall	1	Windshield Wiper	12
Lifters, Valve	5		



1965

**OPERATION AND
CARE OF THE**



**FOLDING TOP
POWER OPERATED**

THE HYDRO-LECTRIC POWER SYSTEM

The convertible coupe incorporates a hydro-lectric system to lower or raise the folding top assembly. After the top has been unlocked from the striker assembly at the windshield header, the top can be lowered and raised, respectively, by actuating the power top control switch. Hydraulic fluid from an electrically driven pump is forced through tubing to double-acting, piston-type cylinders located at each quarter section of the car. Pressurized fluid entering the top of the hydraulic lift cylinders forces the pistons down - thus lowering the top. Pressurized fluid entering the bottom of the hydraulic lift cylinders forces the pistons upward - thus raising the top.

This booklet explains and illustrates the method of operating the folding top and contains information on the care and maintenance of the folding top material, the rear window and proper storage of the folding top boot assembly.

TOP BOOT

The top boot is attached to the body with concealed "floating-type" snap fasteners along the side and rear edges. At the front edge, there is a hook and pile fastener assembly with "floating-type" fasteners at each end. When the folding top is raised, one of the following two methods may be used for storing the boot.

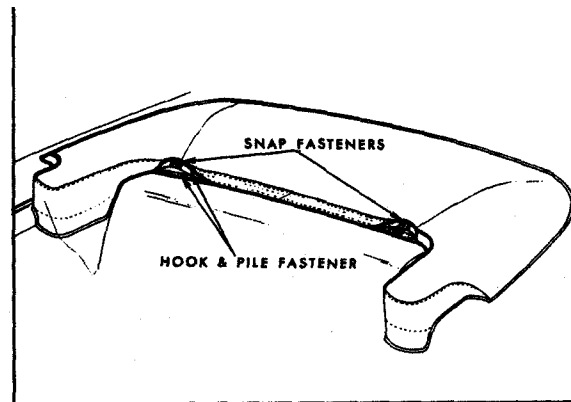

1. The boot may be stored in its protective case in the rear compartment. **IMPORTANT:** If the boot is to be stored in the rear compartment of the car, it must be stored in its protective case to avoid unnecessary soilage or damage.
2. The top boot may be left attached to the pile fastener and folded into the top compartment well behind the rear seat back. **NO OTHER ITEM** should be placed on the top compartment well or beneath the top compartment well from the rear compartment area since it may interfere with the proper operation of the top and may damage the top, the rear window or the top boot. The top boot protective case should be kept in the rear compartment.

TO LOWER THE TOP

1. **STOP THE CAR.** If the top boot has been left attached to the pile fastener and stored behind the rear seat back, turn the boot over the seat back and fold the ends, as shown in the illustration.

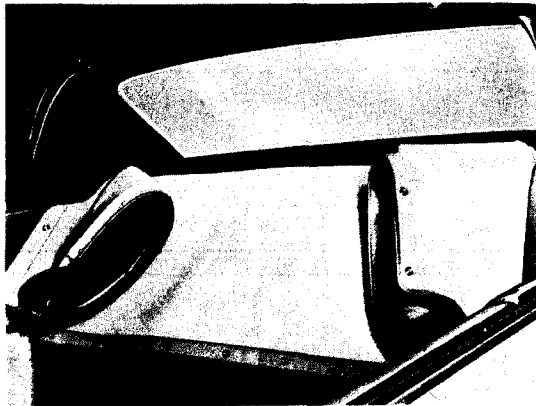

2. Rotate each locking handle inboard until the lock hook lever is disengaged from the striker on the windshield header.

IMPORTANT: DO NOT raise the front roof rail above the windshield header by hand.

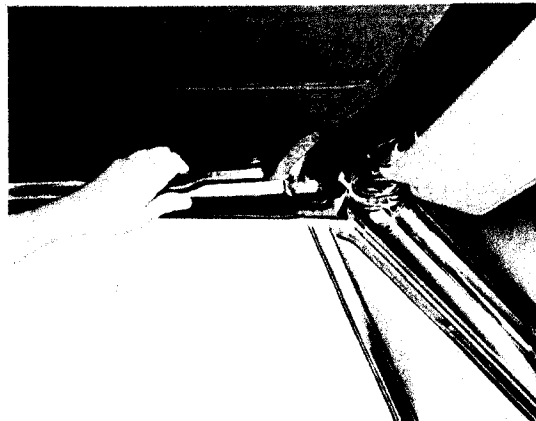

3. Actuate the power top control switch until top is in fully lowered position. 



TOP BOOT INSTALLATION

1. Remove the top boot from the protective case. Place empty protective case in the rear compartment.

2. Place top boot in position over folded top and engage boot fasteners to the studs along the body molding and on the rear quarter trim.

3. Engage fasteners on front of boot to studs on rear seat back panel. Press down on forward edge of boot to secure hook and pile fastener.

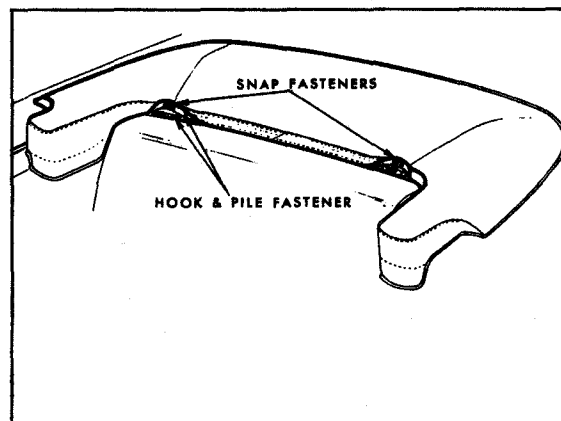

TO RAISE THE TOP

1. **STOP THE CAR.** Disengage all top boot snap fasteners from studs on molding and rear quarter trim. Turn boot ends over the seat back and fold ends of boot toward center of car, as shown in the illustration.

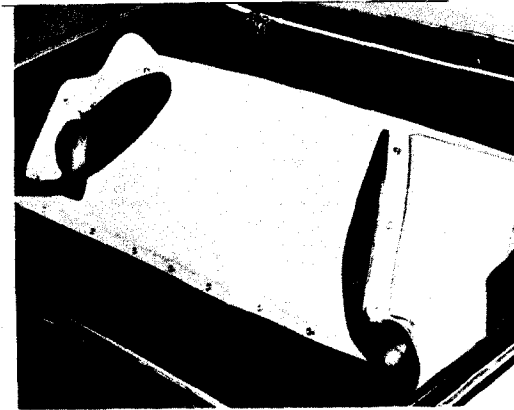

If the top boot is thoroughly dry, the top boot may be removed from the pile fastener, folded and stored in the rear compartment.

IMPORTANT: If the boot is to be stored in the rear compartment of the car, it must be stored in its protective case to avoid unnecessary soilage or damage.

The top boot may be left attached to the pile fastener and folded into the top compartment well behind the rear seat back.

NO OTHER ITEM should be placed on the top compartment well or beneath the top compartment well from the rear compartment area since it may interfere with the proper operation of the top and may damage the top, the rear window or the top boot. The top boot protective case should be kept in the rear compartment.

2. Turn down sun visors and operate power top control switch until top is fully raised and guide studs on the lock assembly are engaged in the striker holes.

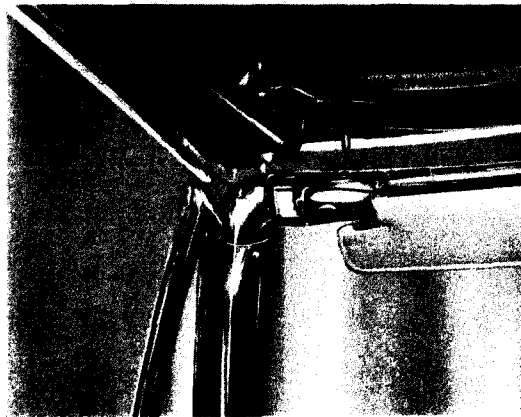

3. Rotate each locking handle outboard until the lock hook lever is fully engaged with striker on windshield header and handle is parallel with the side roof rail.

NOTE: BE SURE TOP IS SECURELY LOCKED TO WINDSHIELD HEADER BEFORE STARTING THE CAR.

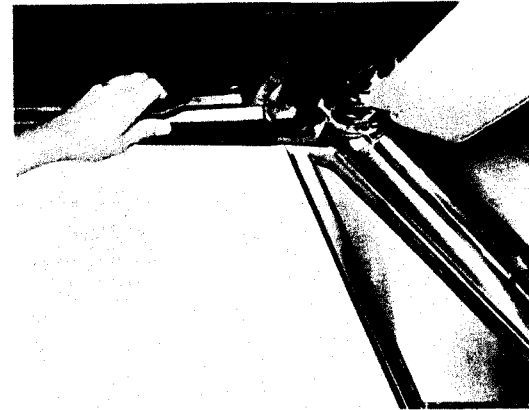

TO LOWER REAR WINDOW

1. Be sure no miscellaneous objects have been placed on the folding top compartment well or beneath the folding top compartment well from the rear compartment area. Any object which obstructs the rear window or top operation could cause damage to the convertible top or rear window glass.
2. Unlock the top from the windshield header.

3. Actuate the power top control switch until top is above the windshield header as shown in illustration.

IMPORTANT: DO NOT raise the front roof rail above the windshield header by hand.

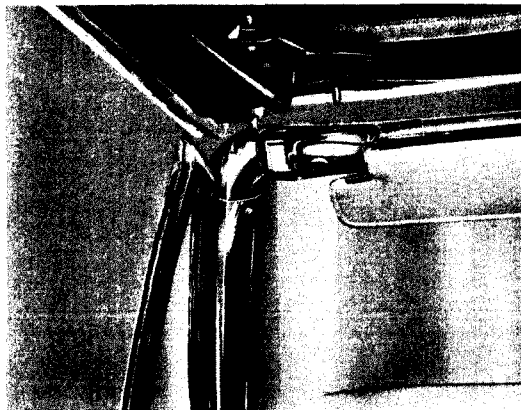

4. Slide zipper fastener, indicated at "A" in illustration, upward and beyond back window retaining strap indicated at "B" in illustration.

IMPORTANT: DO NOT disengage back window retaining strap from rear bow.

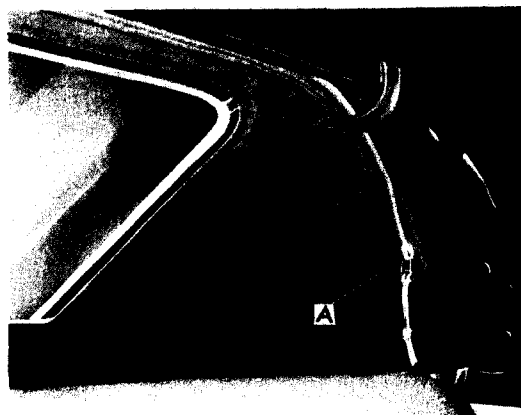



5. Continue operating zipper across top, beyond opposite retaining strap, until zipper reaches the stop at opposite side of window; then, detach lower portion of zipper from zipper slider. →

DO NOT FORCE THE ZIPPER OPEN.

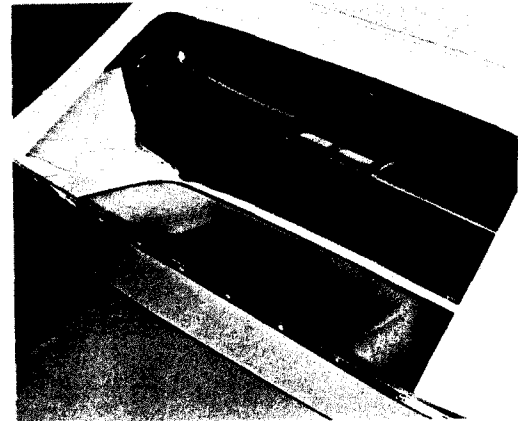
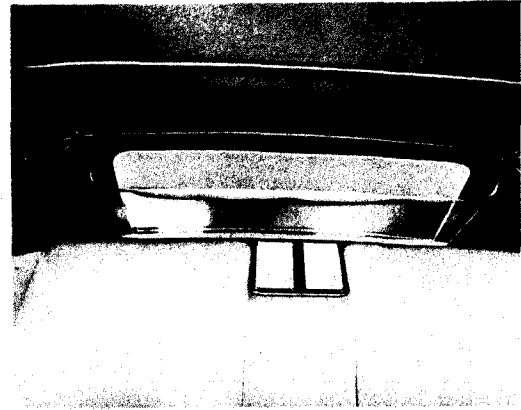
6. While firmly holding window in its approximate closed position, unfasten both retaining straps from rear bow. Carefully lower the window into the top compartment well **DO NOT DROP WINDOW** into top compartment as damage may occur to the glass or zipper. →
7. Lock top to windshield header prior to moving car.



TO RAISE REAR WINDOW

1. Unlock top from windshield header. Using power, raise top off header.
2. Raise window with retaining straps and fasten retaining straps to rear roof bow as shown in illustration. 
3. While holding window in its approximate closed position, engage lower end of zipper into zipper slide. Pull slide upward, across the top, and beyond both retaining straps until slide reaches its closed position. 

DO NOT FORCE THE ZIPPER CLOSED.

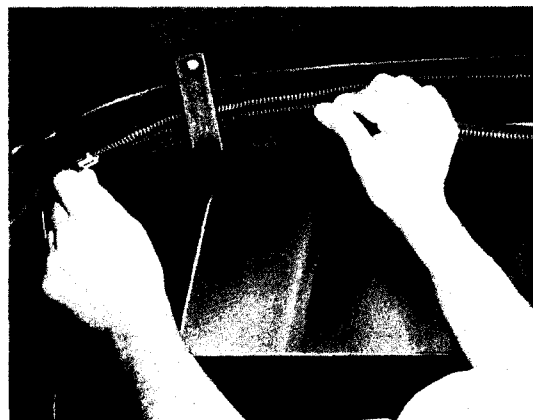
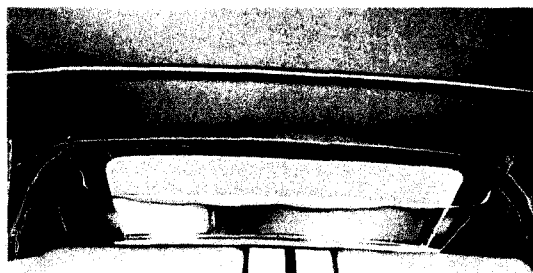

Holding window in its approximate closed position when operating zipper will aid zipper operating effort and prevent jamming of the zipper.

4. Actuate the power top control switch until guide studs on the lock assembly are engaged in the striker holes.
5. Lock top to windshield header prior to moving the car.

CARE OF REAR WINDOW

The back curtain in the Convertible Coupe is provided with a large glass rear window.

DO NOT lower the top when the rear window is dirty. Grit and accumulated foreign matter may scratch the glass.

The rear window glass may be cleaned in the same manner as all body glass.

Volatile cleaning agents should not be used to clean the rear window. These liquids, if spilled, could have a deteriorating effect on the back curtain material, top material or may spot the painted finish on the body panels.

GENERAL INFORMATION

1. **DO NOT OPERATE THE TOP UP OR DOWN WHILE CAR IS IN MOTION.** The top must be securely locked before starting the car.
2. **DO NOT** obstruct the mechanical operation of the top.
3. **DO NOT RAISE** the top above the windshield header by hand.
4. **DO NOT** place miscellaneous objects such as the top boot protective case, golf clubs, luggage, etc., on folding top compartment well or beneath folding top compartment well from the rear compartment area.
5. To prevent water stains, mildew or possible shrinkage of the top material, do not keep the top folded for a long period of time if it is damp or watersoaked.
6. Allow back curtain and top material to become warm and pliable before attempting to operate top in temperatures below 32° fahrenheit.
7. Under certain operating conditions, zipper operation can also be eased by application of silicone, beeswax or non-staining grease stick. This material should be applied as required, the zipper should be cycled several times and then the excess material should be wiped from the zipper.
8. The exposed portions of the hydraulic lift cylinder piston rods should be kept clean of foreign matter. This can be accomplished by raising the top and wiping the exposed portions of the piston rods using a cloth dampened with brake fluid.

CLEANING THE TOP

The top should be washed frequently with neutral soap suds, lukewarm water and a brush with soft bristles. Rinse top with sufficient quantities of clear water to remove all traces of soap.

If the top requires additional cleaning after using soap and water, a mild foaming cleanser can be used. Rinse the whole top with water, then apply a mild foaming type cleanser to the entire top. Scrub with a small soft bristle handbrush, adding water as necessary until the cleanser foams to a soapy consistency. Remove the first accumulated soilage with a cloth or sponge before it can be ground into the top material. Apply additional cleanser to the top and scrub until the top is clean. Care must be exercised to keep the cleanser from running onto bodyfinish as it may cause streaks if allowed to run down and dry. After the entire top has been cleaned, rinse the top generously with clear water to remove all traces of cleanser. If desired, the top can be supported from the underside during the scrubbing operations. After cleaning always be sure the top is thoroughly dry before it is lowered. Lowering the top while it is still wet or damp may cause mildew or unsightly wrinkles.

Do not use volatile cleaners or household bleaching agents on the top material.

GM

FISHER BODY DIVISION
GENERAL MOTORS
CORPORATION

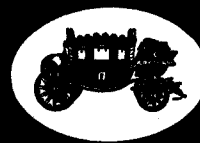

**BODY BY
FISHER**

4226698

LITHO U.S.A.

FIRST EDITION