



Jeep[®]
Selec-Trac

Jeep introduces the most innovative 2-wheel / 4-wheel drive system yet.

Innovative 2-wheel/ 4-wheel

Jeep Selec-Trac

From the world leader in 4-wheel drive technology.

In 1973, Jeep Corporation introduced its exclusive Quadra-Trac® —a full-time 4-wheel drive system with a controlled-slip differential in the transfer case. In 1980, Jeep added a viscous coupling for smooth, quiet operation.

Selec-Trac is the latest Jeep breakthrough and a worthy successor to Quadra-Trac. It com-

bins 2-wheel drive capability, Quadra-Trac's full-time 4-wheel drive and a two-speed transfer case—a world exclusive.

All other utility-type 4-wheelers use a part-time system with limits on its 4-wheel drive use. Selec-Trac's unique full-time system gives you remarkable freedom. You can stay in 4-wheel drive on

any kind of road surface. Travel on dry pavement at sustained highway speeds in quiet comfort. Even stay in 4-wheel drive for the entire season. All with no damage to or excessive wear of the powertrain or tires. Try it yourself with a test drive!



Stay in full-time 4-wheel drive anywhere.



Switch to Low Range for tough spots.

No other drivetrain does so much automatically.

A flick of a switch lets you select 2-wheel drive economy or 4-wheel drive traction.

With Jeep's exclusive, advanced 2-wheel drive/4-wheel drive system, a flick of this switch, after the vehicle is stopped, covers driving situations on or off the road.

Exclusive fingertip control from the driver's seat.

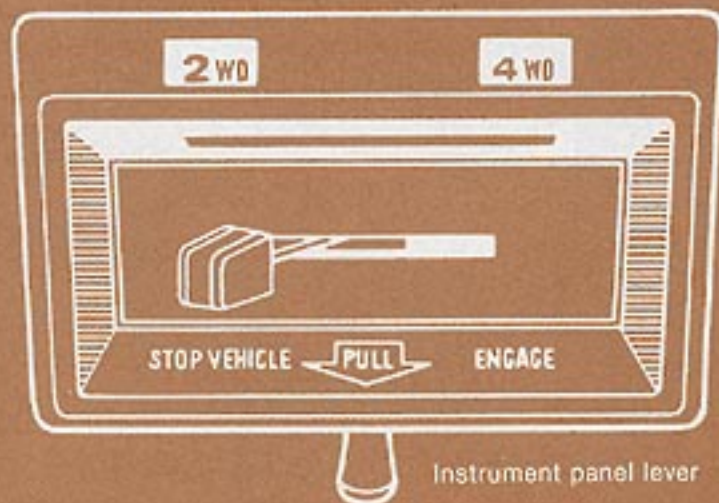

Instrument panel lever

For sticky, off-road situations, a Low Range.

Two-speed transfer case for driving conditions where you need a low range and the low end power that's associated with it.

2.6 to 1 ratio gives you maximum push-pull in 4-wheel drive. A high range for normal 4WD situations.



Transfer case lever

Available on Jeep J-10 Pickup, Cherokee and standard on Wagoneer with automatic transmission.

Here's why Selec-Trac is the world's most innovative drivetrain.

Jeep Selec-Trac lets you stay in 4WD on any road surface with no damage to or excessive wear of the powertrain or tires.

LOW RANGE by-passes controlled slip in transfer case for full power to both axles in difficult 4WD situations.

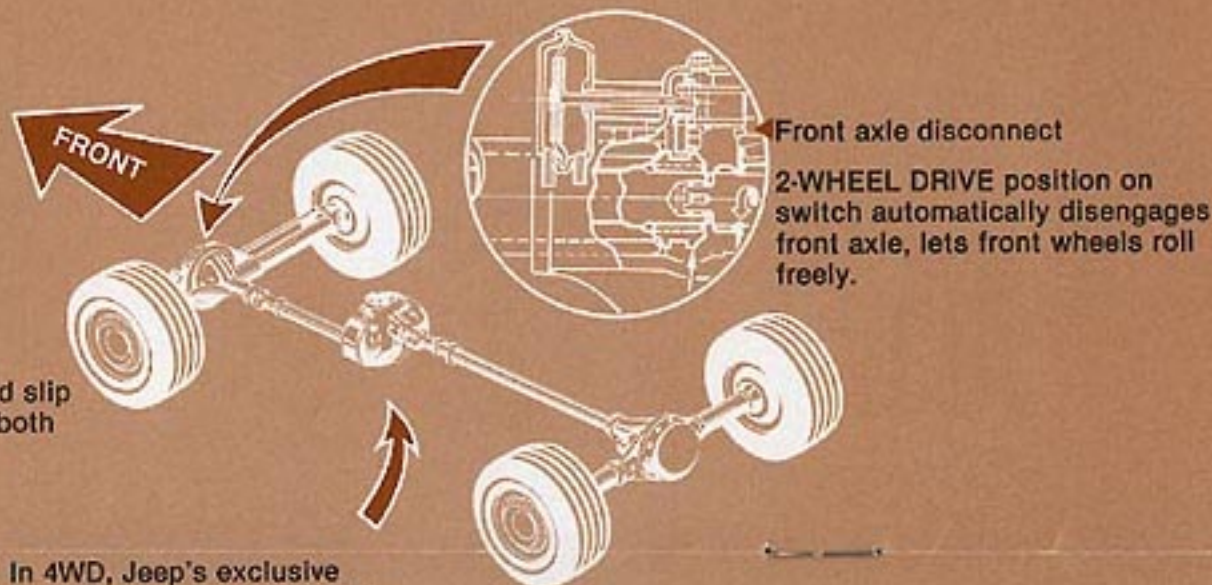

In 4WD, Jeep's exclusive viscous coupling controlled-slip differential in the transfer case automatically delivers power to the axle with the most solid footing.

Simple to operate.

It's just what you expect from the world leader in 4-wheel drive. The world's most versatile drivetrain. And it's so simple to operate.

One switch, mounted on the dashboard, lets you go back and forth between 2-wheel drive economy* and 4-wheel drive

traction. You just stop the vehicle and flick the switch. That's all you have to do for most on- or off-road driving situations.

When you're off the road in a very sticky situation, like deep mud, there's a LOW RANGE. You just stay in 4-wheel drive and move the transfer case lever

below the driver's seat from the normal HIGH position to LOW for extra push-pull traction and power.

And no matter which mode you select, it's all done automatically with fingertip control and without the driver leaving the vehicle.

*See EPA figures on inside back cover

Innovative Selec-Trac gives you superb control when towing a trailer.



Four driving wheels are better than two in controlling the bucking of a trailer—the push-pull of its weight, and in counteracting the wind forces on a trailer—especially cross-winds.

Towing a trailer with a Jeep vehicle equipped with Selec-Trac gives you a double advantage. First of all, in this era of downsized vehicles and engines, it's

comforting to know that with a Jeep vehicle you have a strong, durable towing vehicle with a sturdy frame and Six or V-8 power. It can tow up to 5,000 lbs. (Class III) when properly equipped.

Second, Selec-Trac gives you the freedom and versatility you simply can't find in other 4-wheelers with their part-time 4-wheel drive system. With Selec-

Trac, you can stay in 4-wheel drive anywhere—for superb confidence and control when towing a trailer on dry pavement, around curves, on rainy or snowy roads, and when climbing or going down hills.

And when road conditions are perfect, a flick of a switch gives you the economy of 2-wheel drive.

See your Jeep dealer today for a demonstration of Selec-Trac and for complete trailer towing information.

Now, every Jeep vehicle offers both 2WD and 4WD for the most economical operation.

1 Manual 4WD with manual transmission.



- 4-speed manual, floor-mounted shift.
- 2-speed, floor-mounted, transfer case lever. (2WD, Neutral, 4WD High, 4WD Low.)
- Manual freewheeling front hubs.
- Instrument panel warning light for 4WD mode.



Standard on most Jeep models. (N/A on Wagoneer)

2 Manual 4WD with automatic transmission.



- Column-mounted, automatic transmission lever.
- 2-speed, tunnel-mounted transfer case lever. (2WD, Neutral, 4WD High, 4WD Low.) On CJ and Scrambler, mounted on top of tunnel.
- Manual freewheeling front hubs.
- Instrument panel warning light for 4WD mode.

Optional on all Jeep vehicles except CJ-5 and Wagoneer.



3 Selec-Trac with automatic transmission.



- Column-mounted, automatic transmission lever.
- Instrument-panel-mounted switch for 2-wheel/4-wheel drive.
- 2-speed, tunnel-mounted transfer case lever. (High, Neutral, Low.)



Optional on J-10 Pickup and Cherokee. Standard on Wagoneer.

1983 EPA ESTIMATES—49 STATES

	CJ-5		CJ-7		SCRAMBLER		J-10		J-20		CHEROKEE		WAGONEER	
	Est. Mpg	Hiwy Mpg	Est. Mpg	Hiwy Mpg	Est. Mpg	Hiwy Mpg	Est. Mpg	Hiwy Mpg	Est. Mpg	Hiwy Mpg	Est. Mpg	Hiwy Mpg	Est. Mpg	Hiwy Mpg
4 cyl. 4 speed			22	27	22	27								
6 cyl. 4 speed	18	25	18	25	18	25	18	24			18	24		
Automatic							20	27			18	23	18	23
8 cyl. Automatic							13	18	13	18	13	18	13	18

Use these figures for comparison. Your results may differ due to driving speed, weather, or trip length. Actual highway mileage will be less. California figures may differ.

ONLY FROM JEEP...WORLD LEADER IN 4-WHEEL DRIVE TECHNOLOGY.

Test drive the new Selec-Trac 2WD / 4WD system today.



Jeep J-10 Pickup.



Jeep Cherokee.



Jeep Wagoneer.



Litho U.S.A.

Jeep®, Quadra-Trac®, and Selec-Trac are trademarks of Jeep Corporation, a subsidiary of American Motors Corporation.

Jeep Sales Promotion & Merchandising

8/82

Form #2-5424-835-02