

# MINI

'59 to '69

All models □ 848 cc □ 970 cc  
997 cc □ 998 cc □ 1071 cc □ 1275 cc



THE  
BOOK

## Owners Workshop Manual

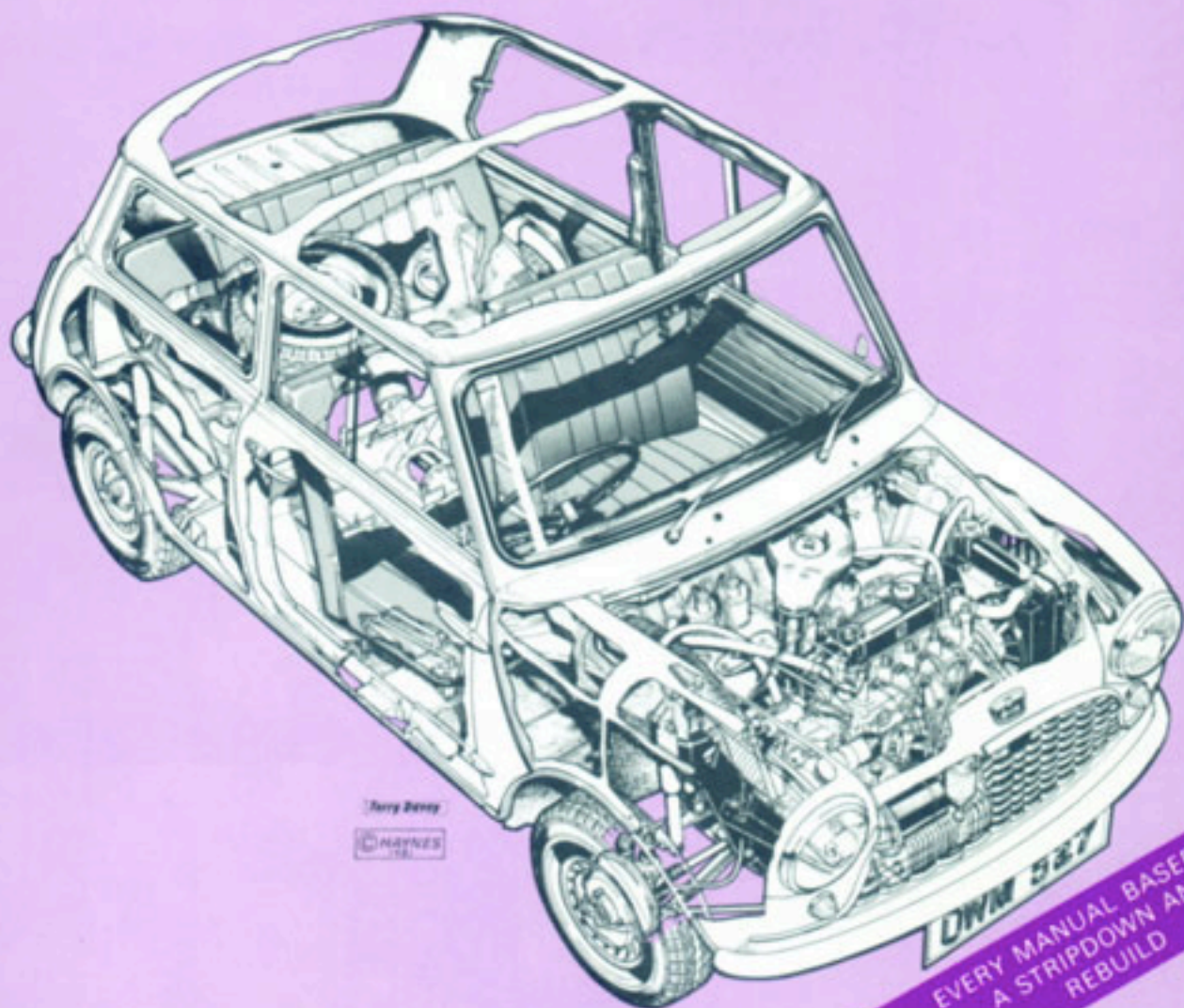

Haynes  
© HAYNES

EVERY MANUAL BASED ON  
A STRIPDOWN AND  
REBUILD

# Chapter 1

## Routine maintenance and servicing



1

### Contents

Air cleaner element renewal . . . . .	30	Fan belt check and renewal . . . . .	8
Air pump drivebelt check and renewal . . . . .	9	Front brake wear check . . . . .	14
Bodywork, paint and exterior trim check . . . . .	28	Fuel filter renewal (fuel injection models) . . . . .	37
Brake fluid renewal . . . . .	36	Fuel system components, checks and lubrication . . . . .	19
Carburettor idle speed and mixture adjustment . . . . .	26	Handbrake check and adjustment . . . . .	4
Clutch hydraulic check . . . . .	10	Headlight beam alignment check . . . . .	12
Clutch return stop adjustment . . . . .	22	Ignition timing check and adjustment . . . . .	25
Contact breaker points check and adjustment . . . . .	20	Intensive maintenance . . . . .	2
Control box cleaning and inspection . . . . .	24	Introduction . . . . .	1
Coolant renewal . . . . .	35	Rear brake wear check . . . . .	17
Distributor cap, rotor arm and HT lead check . . . . .	32	Road test . . . . .	29
Distributor lubrication . . . . .	21	Seats and seat belt check . . . . .	11
Door, boot and bonnet check and lubrication . . . . .	27	Spark plug renewal . . . . .	33
Driveshaft gaiter check . . . . .	15	Steering and suspension check . . . . .	5
Drum brake adjustment . . . . .	3	Steering and suspension lubrication . . . . .	16
Dynamo check and lubrication . . . . .	23	Underbody and fuel/brake line check . . . . .	6
Emission control equipment check . . . . .	34	Underbonnet check for fluid leaks and hose condition . . . . .	18
Engine/transmission oil and filter renewal . . . . .	13	Valve clearance adjustment . . . . .	31
Exhaust system check . . . . .	7		

### Degrees of difficulty

**Easy**, suitable for novice with little experience



**Fairly easy**, suitable for beginner with some experience



**Fairly difficult**, suitable for competent DIY mechanic



**Difficult**, suitable for experienced DIY mechanic



**Very difficult**, suitable for expert DIY or professional



# 1.2 Servicing specifications

<b>Lubricants and fluids</b> .....	Refer to end of "Weekly Checks"	
<b>Capacities</b>		
<b>Engine oil with filter change</b>		
Manual transmission .....	4.8 litres	
Automatic transmission .....	5.0 litres	
<b>Engine oil without filter change (approximate)</b>		
Manual transmission .....	4.2 litres	
Automatic transmission .....	4.4 litres	
<b>Cooling system</b> .....	3.5 litres	
<b>Fuel tank</b>		
Saloon and Clubman (approximate):		
Early models .....	25 litres	
Later models .....	33 litres	
Estate, Van and Pick-up .....	27 litres	
1275 GT .....	33 litres	
Cooper S Mk III .....	50 litres	
<b>Engine</b>		
Oil filter type:		
Pre-1973 models .....	Champion X101 (cartridge type)	
1974-on models .....	Champion C103 (canister type)	
<b>Cooling system</b>		
Fan belt adjustment .....	13.0 mm deflection of belt between crankshaft and dynamo/alternator pulleys	
Specified antifreeze mixture .....	30% antifreeze/70% water	
<b>Note:</b> Refer to Chapter 3 for further details.		
<b>Fuel system - carburettor models</b>		
Air cleaner element type:		
Pre-1973 models .....	Champion W131	
1974-on models .....	Champion W125	
1990-on 1275 cc models .....	Champion W250	
<b>Fuel system - fuel injection models</b>		
Air cleaner element type .....	Champion type not available	
Fuel filter type .....	Champion type not available	
<b>Exhaust and emission control systems</b>		
Air pump drivebelt adjustment .....	13.0 mm deflection of belt between pulleys	
<b>Ignition system</b>		
Spark plugs:*		
Type:		
All models up to 1987 .....	Champion RN9YCC or RN9YC	
998 cc engine models, 1987 to 1989 .....	Champion N12YCC or N12YC	
998 cc engine models (1989-on) .....	Champion RN12YCC or RN12YC	
1275 cc engine models (1990-on) .....	Champion RN9YCC or RN9YC	
Electrode gap:		
All Champion plug types except RN9YC and N12YC .....	0.8 mm	
Champion RN9YC and N12YC .....	0.6 mm	
HT leads .....	Champion LS-02, boxed set	
*Spark plug types and electrode gaps are as recommended by Champion Spark Plug. If alternative plugs are used, refer to their manufacturer's recommendations.		
<b>Clutch</b>		
Clutch return stop clearance .....	0.50 mm	
<b>Brakes</b>		
Minimum brake shoe lining thickness .....	3.0 mm	
Minimum brake pad thickness .....	3.0 mm	
Handbrake lever travel .....	3 clicks of ratchet	
<b>Tyres</b>		
Tyre pressures .....	See "Weekly checks"	
<b>Torque wrench settings</b>		
	<b>Nm</b>	<b>lbf ft</b>
Engine/transmission oil drain plug .....	35	25
Spark plugs .....	25	18
Roadwheel nuts .....	63	45



The maintenance intervals in this manual are provided with the assumption that you, not the dealer, will be carrying out the work. These are the average maintenance intervals recommended by the manufacturer for vehicles driven daily under normal conditions. Obviously some variation of these intervals

may be expected depending on territory of use, and conditions encountered. If you wish to keep your vehicle in peak condition at all times, you may wish to perform some of these procedures more often. We encourage frequent maintenance because it enhances the efficiency, performance and resale value

of your vehicle.

If the vehicle is driven in dusty areas, used to tow a trailer, driven frequently at slow speeds (idling in traffic) or on short journeys, more frequent maintenance intervals are recommended.

## Every 250 miles (400 km) or weekly

- Refer to "Weekly Checks"

## Every 3000 miles (5000 km) or 3 months, whichever comes first

*In addition to the items listed above, carry out the following:*

- Adjust the front and rear drum brakes (Section 3)
- Check the operation of the handbrake and adjust if necessary (Section 4)
- Check the condition and security of the steering and suspension components (Section 5)
- Inspect the underbody and the brake hydraulic pipes and hoses (Section 6)
- Check the condition of the fuel lines (Section 6)
- Check the condition and security of the exhaust system (Section 7)
- Check the condition of the fan belt and renew if necessary (Section 8)
- Check the condition of the air pump drivebelt (where applicable) and renew if necessary (Section 9)
- Inspect the clutch hydraulic components (Section 10)
- Check the condition of the seats and seat belts (Section 11)
- Check the headlight beam alignment (Section 12)

## Every 6000 miles (10 000 km) or 6 months, whichever comes first

*In addition to the items listed above, carry out the following:*

- Renew the engine/transmission oil and filter (Section 13)
- Check the condition of the front brake shoes and/or pads, and renew if necessary (Section 14)
- Check the condition of the driveshaft gaiters (Section 15)
- Lubricate the suspension and steering grease points (Section 16)
- Check the condition of the rear brake shoes and renew if necessary (Section 17)
- Check all underbonnet components and hoses for fluid leaks (Section 18)
- Check and if necessary top up the carburettor piston dashpot and lubricate the linkage (Section 19)

## Every 6000 miles (10 000 km) or 6 months, whichever comes first (continued)

- Check the condition of the contact breaker points and adjust or renew (Section 20)
- Lubricate the distributor (Section 21)
- Check and if necessary adjust the clutch return stop (Section 22)
- Lubricate the dynamo bearing - early models (Section 23)
- Clean and inspect the dynamo charging system control box (Section 24)
- Check and if necessary adjust the ignition timing (Section 25)
- Check and if necessary adjust the carburettor idle speed and mixture settings (Section 26)
- Lubricate the locks and hinges (Section 27)
- Check the condition of the exterior trim and paintwork (Section 28)
- Road test (Section 29)

**Note:** Renewal of the engine/transmission oil and filter at this service interval is only necessary on pre-1985 models. On all other models, oil and filter renewal is recommended at 12 000 miles/12 months.

## Every 12 000 miles (20 000 km) or 12 months, whichever comes first

*In addition to the items listed above, carry out the following:*

- Renew the air cleaner element (Section 30)
- Check and if necessary adjust the valve clearances (Section 31)
- Inspect the distributor cap, rotor arm and HT leads (Section 32)
- Renew the spark plugs (Section 33)
- Check the emission control equipment (Section 34)

## Every 24 000 miles (40 000 km) or twenty four months, whichever comes first

*In addition to the items listed above, carry out the following:*

- Renew the coolant (Section 35)
- Renew the brake fluid (Section 36)
- Renew the fuel filter - fuel injection models (Section 37)



## 1.4 Maintenance - component location

### Underbonnet view of a 998 cc Mini 1000 Saloon

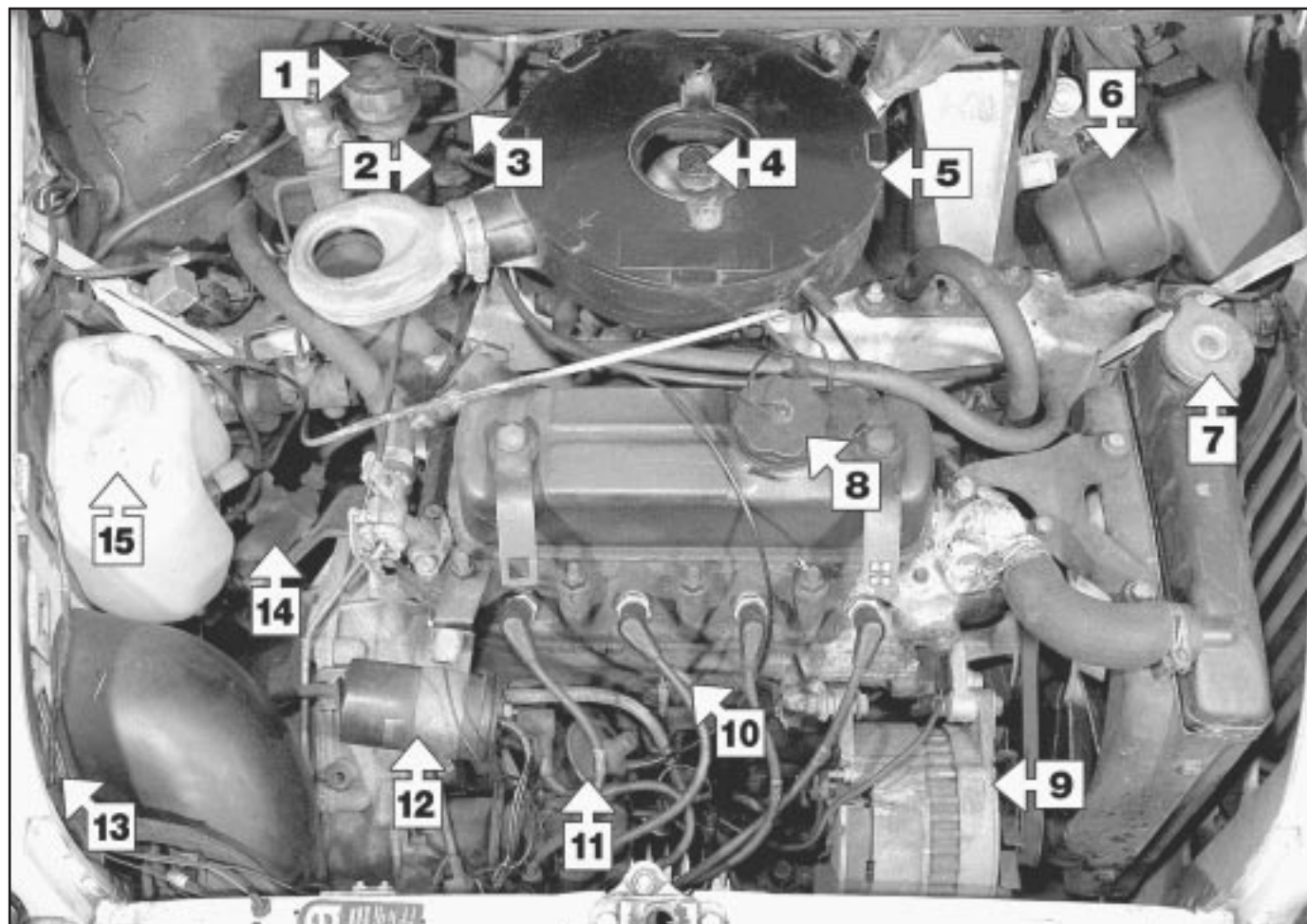

- 1 Brake master cylinder reservoir
- 2 Clutch master cylinder reservoir
- 3 Fuse block
- 4 Carburettor piston damper
- 5 Air cleaner

- 6 Windscreen wiper motor
- 7 Radiator pressure cap
- 8 Engine/transmission oil filler cap
- 9 Alternator
- 10 Engine/transmission oil dipstick

- 11 Distributor
- 12 Ignition coil
- 13 Vehicle identification plate
- 14 Clutch slave cylinder
- 15 Windscreen washer reservoir

## Underbonnet view of a 1275 cc Mini Cooper Saloon

(air cleaner removed for clarity)

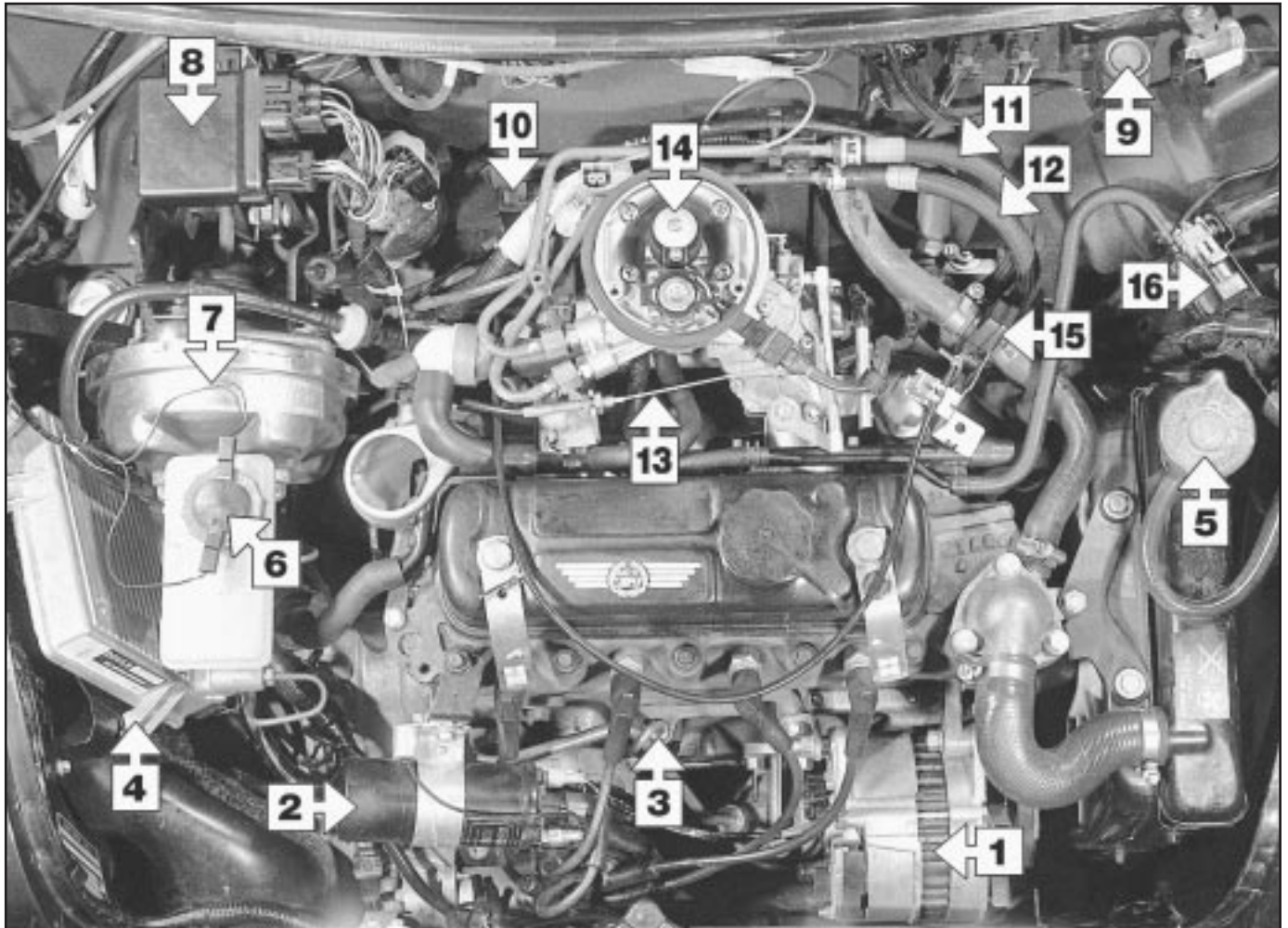

- 1 Alternator
- 2 Ignition coil
- 3 Engine/transmission oil dipstick
- 4 Engine management (fuel injection/ignition) ECU
- 5 Radiator pressure cap

- 6 Brake fluid reservoir cap
- 7 Brake system vacuum servo unit
- 8 Relay module
- 9 Fuel cut-off inertia switch
- 10 Manifold absolute pressure (MAP) sensor fuel trap

- 11 Fuel return pipe
- 12 Fuel feed pipe
- 13 Accelerator cable
- 14 Throttle body assembly
- 15 Heater coolant valve
- 16 Charcoal canister purge valve

## 1.6 Maintenance - component location

### Front underside view of a 998 cc Mini 1000 Saloon

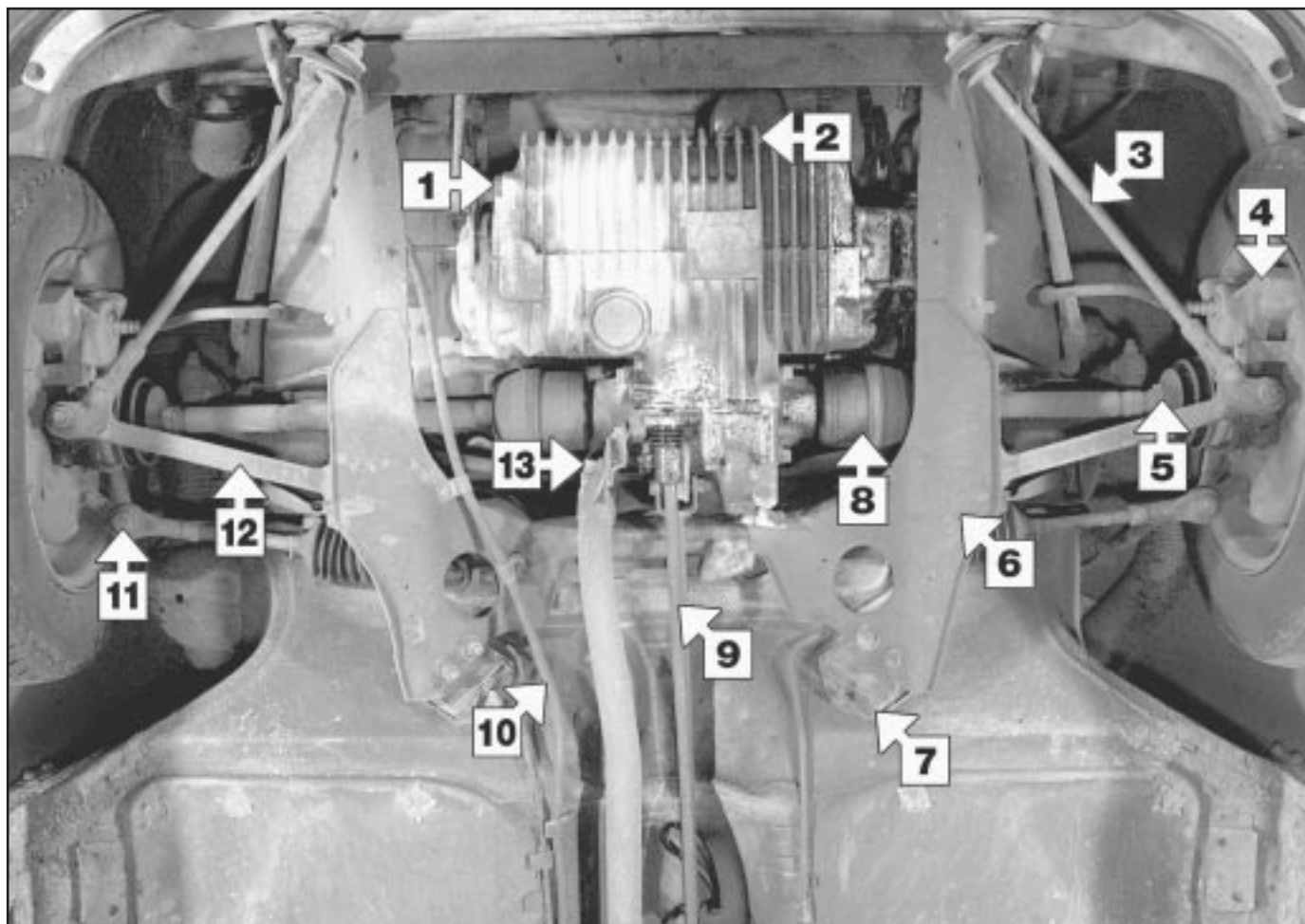

- 1 Engine/transmission oil drain plug
- 2 Oil filter
- 3 Front suspension tie-bar
- 4 Disc brake caliper
- 5 Driveshaft outer CV joint

- 6 Front subframe
- 7 Subframe rear mounting
- 8 Offset sphere type inner CV joint
- 9 Gearchange extension rod
- 10 Battery positive cable

- 11 Steering tie-rod outer balljoint
- 12 Lower suspension arm
- 13 Exhaust bracket



## Rear underside view of a 998 cc Mini 1000 Saloon

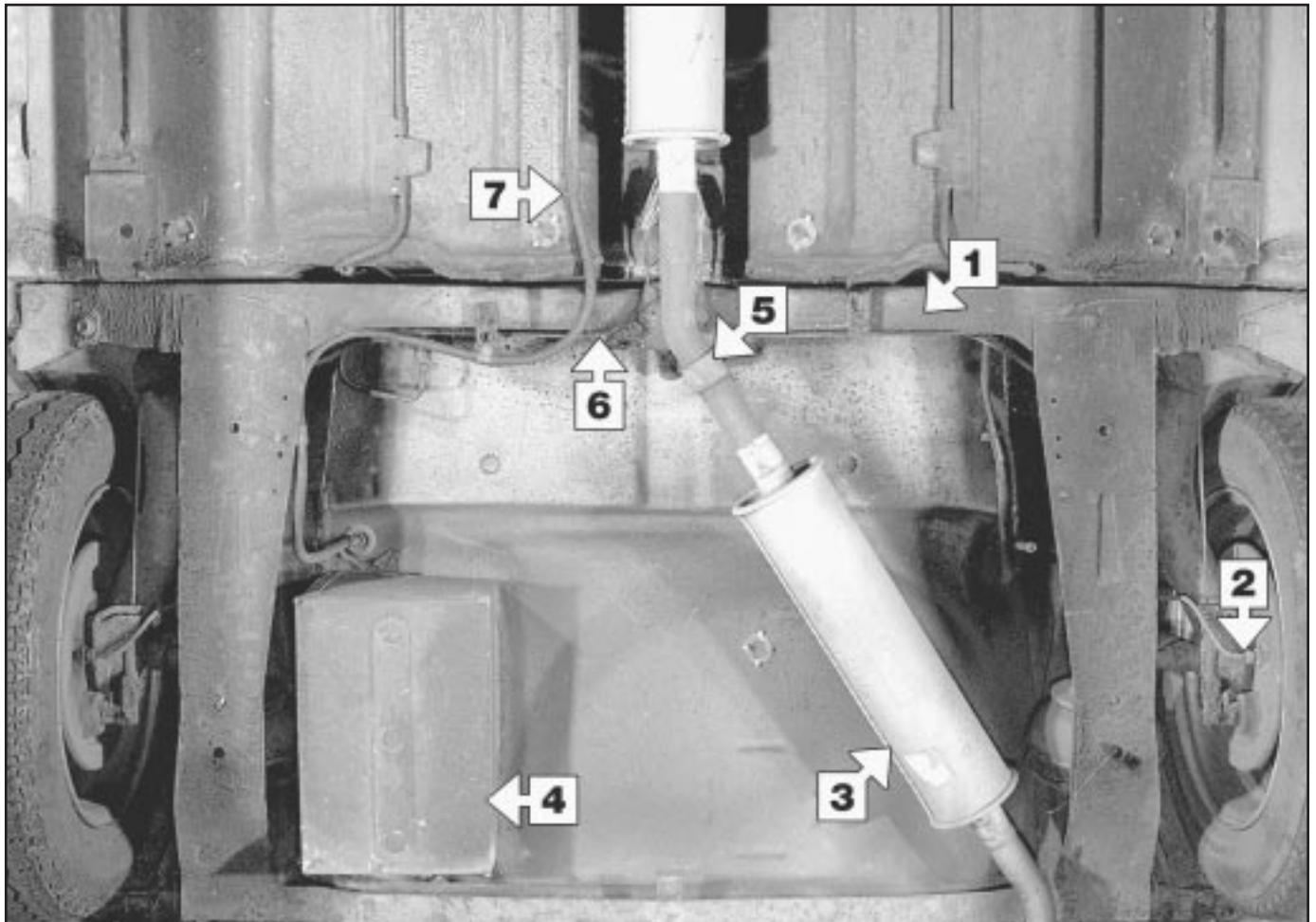

1 Rear subframe

2 Rear brake wheel cylinder attachment

3 Exhaust rear silencer

4 Battery box

5 Exhaust mounting

6 Handbrake cable guide

7 Battery positive cable

# 1.8 Maintenance procedures

## 1 Introduction

1 This Chapter is designed to help the home mechanic maintain his/her vehicle for safety, economy, long life and peak performance.

2 This Chapter contains a master maintenance schedule, followed by Sections dealing specifically with each task in the schedule. Visual checks, adjustments, component renewal and other helpful items are included. Refer to the accompanying illustrations of the engine compartment and the underside of the vehicle for the locations of the various components.

3 Servicing your vehicle in accordance with the mileage/time maintenance schedule and the following Sections will provide a planned maintenance programme, which should result in a long and reliable service life. This is a comprehensive plan, so maintaining some items but not others at the specified service intervals will not produce the same results.

4 As you service your vehicle, you will discover that many of the procedures can - and should - be grouped together, because of the particular procedure being performed, or because of the close proximity of two otherwise-unrelated components to one another. For example, if the vehicle is raised for any reason, the exhaust should be inspected at the same time as the suspension and steering components.

5 The first step of this maintenance programme is to prepare yourself before the actual work begins. Read through all the Sections relevant to the work to be carried out, then make a list and gather together all

the parts and tools required. If a problem is encountered, seek advice from a parts specialist or a dealer service department.

## 2 Intensive maintenance

1 If, from the time the vehicle is new, the routine maintenance schedule is followed closely, and frequent checks are made of fluid levels and high-wear items, as suggested throughout this manual, the engine will be kept in relatively good running condition, and the need for additional work will be minimised.

2 It is possible that there will be some times when the engine is running poorly due to the lack of regular maintenance. This is even more likely if a used vehicle, which has not received regular and frequent maintenance checks, is purchased. In such cases, additional work may need to be carried out, outside of the regular maintenance intervals.

3 If engine wear is suspected, a compression test (refer to Chapter 2A) will provide valuable information regarding the overall performance of the main internal components. Such a test can be used as a basis to decide on the extent of the work to be carried out. If, for example, a compression test indicates serious internal engine wear, conventional maintenance as described in this Chapter will not greatly improve the performance of the engine, and may prove a waste of time and money, unless extensive overhaul work (Chapter 2B) is carried out first.

4 The following series of operations are those often required to improve the performance of a generally poor-running engine:

## Primary operations

- a) Clean, inspect and test the battery (See "Weekly checks").
- b) Check all the engine-related fluids (See "Weekly checks").
- c) Check and if necessary adjust the valve clearances (Section 31).
- d) Check the condition of the fan belt (Section 8).
- e) Top up the carburettor piston damper (Section 19).
- f) Check the condition and adjustment of the contact breaker points (Section 20).
- g) Inspect the distributor cap, rotor arm and HT leads (Section 32).
- h) Renew the spark plugs (Section 33).
- i) Check and if necessary adjust the ignition timing (Section 25).
- j) Check the condition of the air cleaner filter element and renew if necessary (Section 30).
- k) Check and if necessary adjust the carburettor idle speed and mixture settings (Section 26).
- l) Renew the fuel filter - fuel injection models (Section 37).
- m) Check the condition of all hoses, and check for fluid leaks (Section 18).

5 If the above operations do not prove fully effective, carry out the following operations:

## Secondary operations

All the items listed under "Primary operations", plus the following:

- a) Check the charging system (Chapter 5A).
- b) Check the ignition system (Chapter 5B).
- c) Check the fuel system (Chapter 4A and B).
- d) Renew the distributor cap and rotor arm (Section 32).
- e) Renew the ignition HT leads (Section 32).

## Every 3000 miles or 3 months

### 3 Drum brake adjustment



1 As wear takes place on the brake shoe friction material, the clearance between the friction material and the inner circumference of the brake drum will increase, resulting in excessive brake pedal travel before the brakes are applied. To compensate for this, adjusters are provided at the rear of each brake backplate, enabling the clearance between the brake shoe and drum to be kept to a minimum.

2 At the front two adjusters are fitted to each brake backplate. At the rear a single adjuster is located at the top of each brake backplate.

#### Front brakes

3 Chock the rear wheels then jack up the front of the car and support it on axle stands (see "Jacking and vehicle support").

4 Each front brake has two adjusters of the eccentric cam type, accessible from the rear of each brake backplate. One of these adjusters is located behind the steering arm and insufficient clearance exists to enable an ordinary brake adjusting spanner to be used. Providing the adjuster is not excessively tight or partially seized in the backplate, a  $\frac{3}{16}$  in AF open-ended spanner can be used quite successfully to turn the adjuster.

5 Begin by turning one of the adjusters in the forward direction of wheel rotation until the wheel is locked (see illustration). Now back it off slightly, until the wheel turns freely. The brake drum may rub slightly in one or two places as the wheel is turned. This is acceptable providing the wheel does not bind.

**Caution:** If, when attempting to adjust the brakes, the square-headed adjuster is reluctant to turn, it is quite likely that it has become seized in its housing. If this is the case do not force it, or you will probably break off the square head, necessitating

renewal of the complete backplate assembly. Apply liberal amounts of penetrating oil to the rear of the adjuster and allow it to soak in. Now turn the adjuster back and forth slightly, using gentle force if necessary, increasing the movement each time. When the adjuster turns easily apply a multipurpose grease to



3.5 Adjusting one of the front brake adjusters with a brake adjusting spanner



3.9 Adjusting the rear brakes

*the exposed portion of the adjuster at the rear of the backplate and then turn it through its entire travel. Preferably do this with the brake drum removed.*

6 Turn the second adjuster also in the direction of forward wheel rotation until the drum locks again. Now back the adjuster off until the wheel turns freely once more.

7 Repeat this procedure for the other front wheel and then lower the car to the ground.

### Rear brakes

8 Chock the front wheels then jack up the rear of the car and support it on axle stands (see "Jacking and vehicle support"). Ensure that the handbrake is off.

9 Using a brake adjusting spanner, turn the square-headed adjuster in a clockwise direction (viewed from the rear of the backplate) until the wheel is locked (see illustration). The adjusters on the rear brakes are even more prone to seizure than those at the front. If the adjuster is reluctant to turn attempt to free it off as described above. If this fails, remove the rear brake drums and brake shoes as described in Chapter 9, and clean and lubricate the adjuster thoroughly. When all is well, refit the brake assemblies and start the adjustment procedure again.

10 Now turn the adjuster back a quarter of a

turn at a time until the wheel turns freely without binding. A slight rubbing may be felt when the wheel is turned slowly, indicating a high spot on the drum or dust on the linings. This is acceptable providing the drum does not bind.

11 Repeat this procedure for the other rear brake then, before lowering the car to the ground, check the handbrake adjustment as described in the following Section.

### 4 Handbrake check and adjustment

1 Adjustment of the handbrake cables is usually only necessary after high mileage when a slight stretching of the cables will have taken place, or if the cables have been removed.

2 Before adjusting the handbrake check that the footbrake is correctly adjusted as described in Section 3.

3 Chock the front wheels then jack up the rear of the car and support it on axle stands (see "Jacking and vehicle support").

4 Apply the handbrake lever to the third notch of the ratchet and check that the rear wheels are locked. If not, adjust the handbrake as follows.

5 With the handbrake still applied to the third click of the ratchet, tilt the front seats forward, and on models having twin cables, tighten the cable adjusting nuts at the base of the lever until the rear wheels can only just be turned by heavy hand pressure. On models having a single front cable, slacken the locknut and rotate the cable adjusting nut. When the wheels can only just be turned by heavy hand pressure, tighten the locknut (see illustrations).

6 Release the handbrake lever and ensure that the wheels rotate freely. If satisfactory lower the car to the ground.

### 5 Steering and suspension check



#### Steering

1 First check for wear in the steering tie-rod outer balljoints. Turn the steering to left or right lock sufficiently to allow the joints to be observed. Now have an assistant turn the steering wheel back and forth slightly. If there is any side movement in the balljoint it must be renewed. Similarly place your hand over the rubber gaiter at the end of the rack housing and feel for any excess free play of the inner balljoint. If the condition of this joint is suspect, a further investigation should be carried out with the gaiter removed as described in Chapter 10.

2 Check the tightness of the steering column clamp bolt at the base of the column. Any slackness at this joint can also show up as free play at the steering wheel.

#### Front suspension

3 To inspect the front suspension, chock the rear wheels then jack up the front of the car and support it on axle stands (see "Jacking and vehicle support").

4 Visually inspect the balljoint dust covers and the steering gear gaiters for splits, chafing or deterioration. Any wear of these components will cause loss of lubricant, together with dirt and water entry, resulting in rapid deterioration of the balljoints or steering gear.

5 Grasp the roadwheel at the 12 o'clock and 6 o'clock positions and try to rock it. If any movement is felt it is likely to be in one or more of the following areas:

#### Hub bearings

6 Continue rocking the wheel while your assistant depresses the footbrake. If the

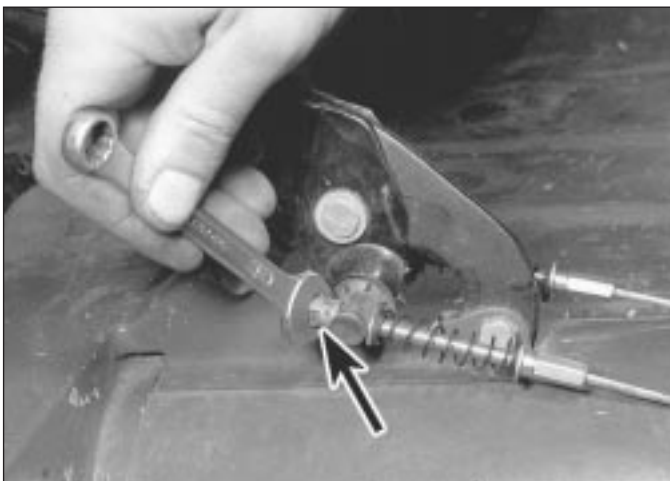

4.5a Handbrake adjustment on models with twin cables



4.5b Handbrake cable adjusting nut on models with a single front cable



# 1•10 Every 3000 miles or 3 months

movement disappears or becomes less severe, then the wheel hub bearings in the swivel hub are at fault. Any perceptible movement at all indicates wear in the hub bearings, and they should be renewed as described in Chapter 10.

## Swivel hub balljoints

**7** Wear of the swivel hub balljoints is fairly common on Minis and will be quite obvious on inspection because the whole swivel hub will appear to move in relation to the suspension arms as the wheel is rocked. If this is the case, the balljoints should be adjusted, or if badly worn, renewed; these procedures are contained in Chapter 10.

## Suspension arm mountings

**8** Check for wear of the lower arm inner mounting bushes where the arm is bolted to the subframe. If the bushes are worn, the arm will appear to move in and out as the wheel is rocked.

**9** The upper arm inner roller bearings cannot be inspected without partially dismantling the suspension because the rubber cone spring or displacer unit holds the arm in tension and any wear will not be evident. It can be removed for closer inspection if required as described in Chapter 10; however, wear of the upper arm and its bearings is uncommon.

**10** With the brakes still firmly applied, try to rotate the wheel back and forth. If any movement is now felt, examine the tie-bar between the lower suspension arm and subframe for wear or deterioration of the rubber bushes.

## Rear suspension

**11** To check the rear suspension for wear, chock the front wheels then jack up the rear of the car and support it on axle stands (see "Jacking and vehicle support").

**12** Wear of the rear suspension components can often be felt when driving the car as a tendency for the rear of the vehicle to wander over uneven road surfaces or when cornering.

To isolate the worn components, grasp the roadwheel at the 12 o'clock and 6 o'clock positions and try to rock it. If any movement is felt, it is likely to be in one of the following areas:

## Hub bearings

**13** Continue rocking the wheel while an assistant depresses the footbrake. If the movement disappears or becomes less pronounced, then the bearings in the rear hub are at fault. The bearings should be renewed if there is any appreciable movement whatsoever.



**Wear in the rear hub bearings can often be confirmed by slowly turning the wheel with your hand on the tyre. Worn bearings usually exhibit a roughness which can be felt as the wheel is turned.**

## Radius arm bearings

**14** With the footbrake still applied, continue rocking the wheel and observe the front of the radius arm. If it can be seen to move appreciably up and down, then wear has taken place in the roller or plain bearing in the radius arm, or on the pivot shaft. If this is the case, the radius arm should be removed for overhaul as described in Chapter 10.

## 6 Underbody and fuel/brake line check



**1** With the vehicle raised and supported on axle stands (see "Jacking and vehicle support"), or over an inspection pit, thoroughly inspect the underbody and wheel arches for signs of damage and corrosion. In particular, examine the bottom of the side sills, and any concealed areas where mud can collect. Where corrosion and rust is evident, press and tap firmly on the panel with a screwdriver, and check for any serious corrosion which would necessitate repairs. If

the panel is not seriously corroded, clean away the rust, and apply a new coating of underseal. Refer to Chapter 11 for more details of body repairs.

**2** At the same time, inspect the treated lower body panels for stone damage and general condition.

**3** Examine the subframes carefully, particularly the side members of the rear subframe. Corrosion here is a common occurrence on Minis, particularly older models, and is one of the main causes of MOT test failure on these cars (see illustration). Where corrosion has reached an advanced stage, renewal of the subframe is the only satisfactory cure.

**4** Inspect all of the fuel and brake lines on the underbody for damage, rust, corrosion and leakage. Also make sure that they are correctly supported in their clips. The battery positive cable which runs under the car from front to rear is a common problem area as it is prone to damage or chafing if not properly routed or secured.

**5** Inspect the flexible brake hoses in the vicinity of the backplates or front calipers, where they are subjected to most movement (see illustration). Bend them between the fingers (but do not actually bend them double, or the casing may be damaged) and check that this does not reveal previously hidden cracks, cuts or splits.

## 7 Exhaust system check



**1** With the engine cold (at least three hours after the vehicle has been driven), check the complete exhaust system, from its starting point at the engine to the end of the tailpipe. Ideally, this should be done on a hoist, where unrestricted access is available; if a hoist is not available, raise and support the vehicle on axle stands (see "Jacking and vehicle support").

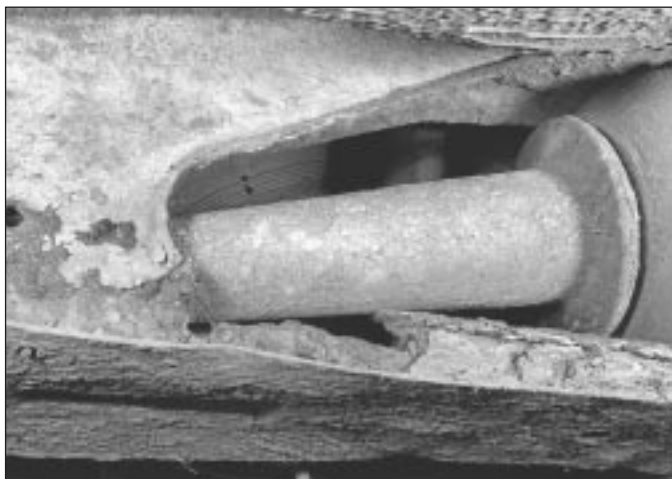

6.3 Advanced state of corrosion on rear subframe side member



6.5 Inspect the flexible brake hoses in the vicinity of the backplates

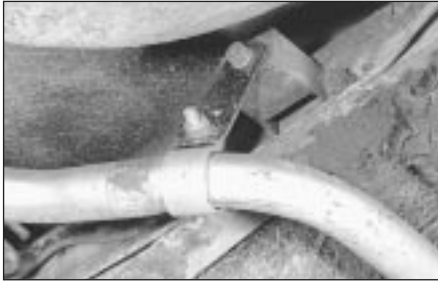

7.2a Exhaust front mounting block . . .



7.2b . . . and rear mounting block on rear subframe



8.6 Dynamo adjusting arm nut located below the water pump

**2** Check the pipes and connections for evidence of leaks, severe corrosion, or damage. Make sure that all brackets and rubber mountings are in good condition, and tight; if any of the mountings are to be renewed, ensure that the replacements are of the correct type. Failure of the rear mounting rubber blocks on the rear subframe is a common problem - check these carefully (**see illustrations**). Leakage at any of the joints or in other parts of the system will usually show up as a black sooty stain in the vicinity of the leak.

**3** At the same time, inspect the underside of the body for holes, corrosion, open seams, etc. which may allow exhaust gases to enter the passenger compartment. Seal all body openings with silicone or body putty.

**4** Rattles and other noises can often be traced to the exhaust system, especially the rubber mountings. Try to move the system, silencer(s) and catalytic converter. If any components can touch the body or suspension parts, secure the exhaust system with new mountings.

method, and the method that should be used on automatic transmission models, is to press the fan belt midway between the water pump pulley and dynamo or alternator pulley and then turn the fan blades.



**Turning the engine will be easier if the spark plugs are removed first - see Section 33.**

**2** Examine the belt for cracks, splitting, fraying or damage. Check also for signs of glazing (shiny patches) and for separation of the belt plies. Renew the fan belt if worn or damaged.

**3** If the condition of the belt is satisfactory, check the adjustment as follows.

**4** It is most important to keep the fan belt correctly adjusted; if the belt is too loose it will slip and wear rapidly, resulting in inefficient operation of the water pump and dynamo or alternator. If it is too tight, it will impose excessive strain on the bearings of the water pump, dynamo or alternator causing premature failure of these components.

**5** The fan belt tension is correct when there is 13 mm of fan belt deflection, using light finger pressure, at a point midway between

the crankshaft and dynamo or alternator pulleys.

**6** To adjust the fan belt, slacken the mounting bolts of the dynamo or alternator, and also the nut on the adjusting arm located below the water pump (**see illustration**). Now move the unit either in or out until the correct tension is obtained. It is easier if the adjusting arm nut is only slackened a little so it requires some force to move the dynamo or alternator. In this way the tension of the belt can be arrived at more quickly than by making frequent adjustments. If difficulty is experienced in moving the dynamo or alternator away from the engine, a long spanner or bar placed behind the unit and resting against the block serves as a very good lever and can be held in position while the adjusting and mounting bolts are fully tightened. When levering on an alternator, only lever on the drive end or damage may occur.

**7** When the tension is correct, tighten the adjusting arm nut first, followed by the mounting bolts.

**Renewal**

**8** To remove the fan belt, slacken the two dynamo or alternator upper mountings and the nut on the adjusting arm below the water pump (**see illustrations**).



**When checking the exhaust, pay particular attention to the mounting on the transmission. Movement of the engine causes this mounting to work loose, causing an annoying squeak or rattle when accelerating and decelerating.**

**8 Fan belt check and renewal**



**Note:** If the car is fitted with exhaust emission control equipment it will first be necessary to remove the air pump drivebelt as described in Section 9 to allow access to the fan belt.

**Check and adjustment**

**1** Release the three retaining lugs and remove the engine ignition shield, if fitted. Rotate the crankshaft so that the entire length of the fan belt can be examined. On manual transmission models, the engine can be rotated quite easily by engaging top gear and moving the car backwards or forwards to allow the belt to be inspected. This should only be done on level ground; and make sure that the car cannot run away! An alternative

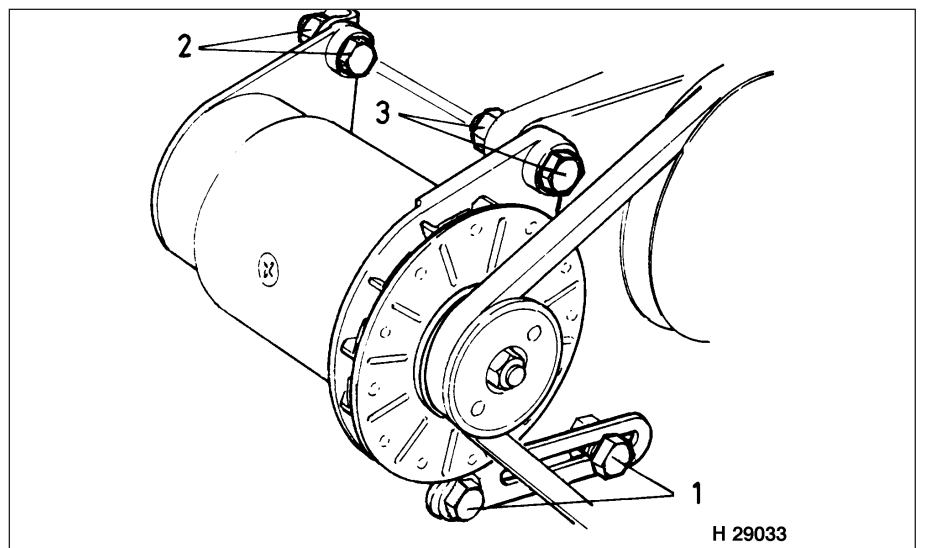

8.8a Dynamo mountings and adjustment points

- 1 Adjustment arm retaining nuts
- 2 Securing nut and bolt (rear)
- 3 Securing nut and bolt (front)

H 29033

# 1•12 Every 3000 miles or 3 months

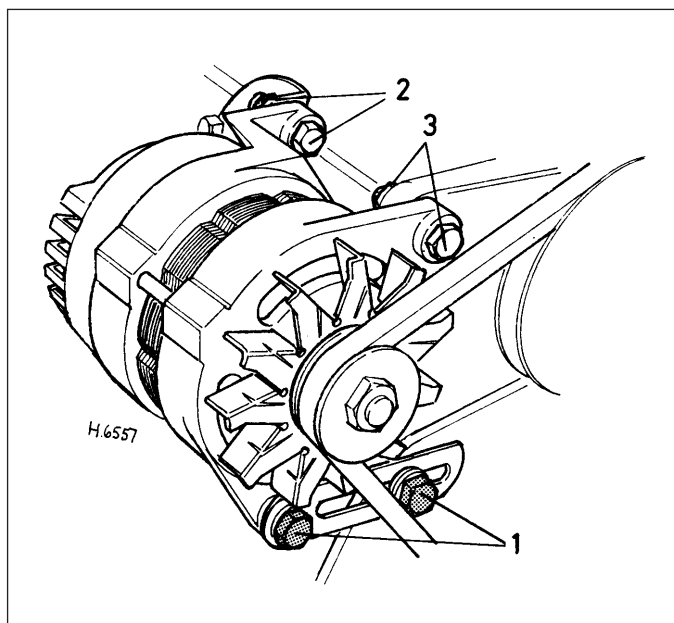

8.8b Alternator mounting and adjustment points

- 1 Adjustment arm fixings      3 Securing nut and bolt (front)  
2 Securing nut and bolt (rear)

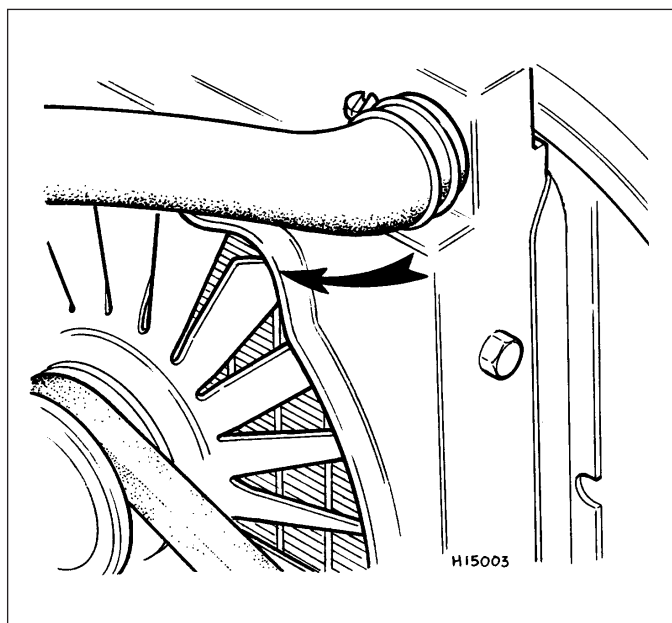

8.9 The gap in the radiator shroud of early models (arrowed) to allow removal and refitting of the fan belt

**9** Push the dynamo or alternator toward the engine and lift the old belt off the three pulleys. Feed the belt over each fan blade in turn and withdraw it from behind the fan cowl at the special gap just below the top hose (**see illustration**).

**10** Fit the new belt over the fan blades in the same way and then place it in position on the three pulleys.

**11** Adjust the fan belt tension as described previously then refit the air pump drivebelt, where applicable, as described in the following Section. **Note:** After fitting a new fan belt, check and if necessary readjust the tension after 250 miles (400 km).

**4** Unscrew the radiator filler cap and slacken the top hose securing clips. Carefully ease the radiator as far as possible toward the wing valance. Place a container beneath the engine to catch the small quantity of coolant that will be lost as the top hose is released.



**Warning:** If the engine is hot, take precautions against scalding.

**5** Slacken the air pump pivot and adjusting link bolts, push the pump in toward the engine, and slip the drivebelt off the two pulleys.

**6** Feed the belt between the fan blades and the radiator cowl at the top as the blades are rotated. Now pull the belt out from between the fan and radiator.

**7** Refitting the drivebelt is the reverse sequence to removal, adjusting the tension as described previously. Top up the cooling system as described in "Weekly Checks" on completion.

Check for signs of fluid leaks around the slave cylinder rubber boot or from the feed pipe and hose. Apply a few drops of oil to the clutch operating lever clevis pin and the pivot on the flywheel housing.

## 11 Seats and seat belt check



**1** Check that the seats are securely attached to the floor crossmember and that there is no sign of corrosion anywhere near the mountings. Check that the seats release and then lock in place when the release mechanism is operated.

**2** Check the seat belts for satisfactory operation and condition. Inspect the webbing for fraying and cuts. Check that they retract smoothly and without binding into their reels.

**3** Check the seat belt mountings, ensuring that all the bolts are securely tightened.

## 9 Air pump drivebelt check and renewal



### Check and adjustment

**1** The checks and adjustment procedure for the air pump drivebelt are basically the same as described in Section 9 for the fan belt. Adjust the tension of the drivebelt so that there is 13 mm deflection of the belt, using thumb pressure, at a point midway between the two pulleys.

### Renewal

**2** Release the three retaining lugs and remove the engine ignition shield, if fitted.

**3** Undo and remove the two bolts securing the radiator upper mounting bracket to the radiator.

## 10 Clutch hydraulic check

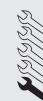

**1** Check that the clutch pedal moves smoothly and easily through its full travel, and that the clutch itself functions correctly, with no trace of slip or drag.

**2** Apply a few drops of light oil to the clutch pedal pivot.

**3** From within the engine compartment check the condition of the fluid lines and hoses.

## 12 Headlight beam alignment check



Accurate adjustment of the headlight beam is only possible using optical beam-setting equipment, and this work should therefore be carried out by a Rover dealer or service station with the necessary facilities.

Basic adjustments can be carried out in an emergency, and further details are given in Chapter 12.



**13 Engine/transmission oil and filter renewal**



**1** Frequent oil changes are the best preventive maintenance the home mechanic can give the engine, because ageing oil becomes diluted and contaminated, which leads to premature engine wear.

**2** Make sure that you have all the necessary tools before you begin this procedure. You should also have plenty of rags or newspapers handy, for mopping up any spills. The oil should preferably be changed when the engine is still fully warmed-up to normal operating temperature, just after a run; warm oil and sludge will flow out more easily. Take care, however, not to touch the exhaust or any other hot parts of the engine when working under the vehicle. To avoid any possibility of scalding, and to protect yourself from possible skin irritants and other harmful contaminants in used engine oils, it is advisable to wear gloves when carrying out this work. Access to the underside of the vehicle is greatly improved if the vehicle can be lifted on a hoist, driven onto ramps, or supported by axle stands. (see *"Jacking and vehicle support"*). Whichever method is chosen, make sure that the vehicle remains level, or if it is at an angle, that the drain point is at the lowest point.

**Oil draining**

**3** Position the draining container under the drain plug on the side of the transmission casing, and unscrew the plug (see **illustration**). If possible, try to keep the plug pressed into the sump while unscrewing it by hand the last couple of turns.

**4** Allow the oil to drain into the container (see **Haynes Hint**), and check the condition of the plug's sealing washer; renew it if worn or damaged. Also wipe off any metal particles that may have accumulated on the magnet.

**5** Allow some time for the old oil to drain, noting that it may be necessary to reposition the container as the oil flow slows to a trickle; when the oil has completely drained, wipe clean the drain plug and its threads in the transmission and refit the plug, tightening it to the specified torque.



**13.3 Engine/transmission oil drain plug (arrowed)**

**Oil filter renewal**

**6** The oil filter is located underneath the dynamo or alternator on the forward-facing side of the engine. On early manual transmission models the filter is of the disposable cartridge type contained within an aluminium bowl. On later models a throwaway canister is used. All automatic transmission models utilise the cartridge type filter. To renew the filter proceed as follows.

**Cartridge type**

**7** Reposition the draining container under the oil filter then undo and remove the long centre bolt securing the bowl to the housing (see **illustration**). On some models it may be advantageous to remove the grille panel, as space is rather limited.

**8** With the bolts released, carefully lift away the filter bowl, which contains the filters and will also be full of oil.

**9** Discard the old filter element but first make sure that the metal pressure plate has not stuck to the bottom of it. Now thoroughly clean out the filter bowl, the bolt, and the parts associated with it, using paraffin or a suitable solvent (see **illustration**) Dry with a lint free cloth

**10** A rubber sealing ring is located in a groove round the head of the filter housing and forms an effective leak-proof joint between the housing and the filter bowl. A new rubber sealing ring is supplied with each new filter element.

**11** Carefully prise out the old sealing ring from the locating groove. If the ring has become hard and is difficult to move take



**Keep the drain plug pressed into the sump while unscrewing it by hand the last couple of turns. As the plug releases, move it away sharply so the stream of oil issuing from the sump runs into the container, not up your sleeve!**

great care not to damage the sides of the sealing ring groove.

**12** With the old ring removed, fit the new ring in the groove at four equidistant points and press it home a segment at a time. Do not insert the ring at just one point and work round the groove pressing it home as, using this method, it is easy to stretch the ring and be left with a small loop of rubber which will not fit into the locating groove (see **illustration**).

**13** Reassemble the oil filter assembly by first passing up the bolt through the hole in the bottom of the bowl, with a steel washer under the bolt's head and a rubber or felt washer on top of the steel washer and next to the filter bowl.

**14** Slide the spring over the bolt followed by the other steel washer, the remaining rubber washer and finally the filter pressure plate concave face downwards.

**15** After fitting the new element to the bowl, position the bowl on the rubber sealing ring then insert and hand tighten the bolt. Before finally tightening the centre bolt, ensure that the lip of the filter bowl is resting squarely on the rubber sealing ring and is not offset or seated off the ring. If the bowl is not seating properly, rotate it until it is. Run the engine and check the bowl for leaks.



**13.7 Cartridge type oil filter and retaining bolt as seen from below**



**13.9 Components of the cartridge type oil filter**



**13.12 Fitting a new cartridge type oil filter sealing ring**

# 1•14 Every 6000 miles or 6 months

## Canister type

**16** Reposition the draining container under the oil filter then, using a suitable filter removal tool if necessary, slacken the canister initially, then unscrew it by hand the rest of the way; be prepared for some oil spillage (see illustration). Empty the oil in the old canister into the container.

**17** Using a clean, lint-free rag, wipe clean the cylinder block around the filter housing. Check the old canister to make sure that the rubber sealing ring hasn't stuck to the filter housing; if it has, carefully remove it.

**18** Apply a light coating of clean engine oil to the sealing ring on the new canister. Screw the canister into position on the housing until it seats, then tighten it firmly by hand only - **do not** use any tools.

**19** Remove the old oil and all tools from under the vehicle, then lower the vehicle to the ground.

## Oil filling

**20** Remove the dipstick and the oil filler cap from the engine. Fill the engine with oil, using the correct grade and type of oil, (see *Specifications*). Pour in half the specified quantity of oil first, then wait a few minutes for the oil to fall to the transmission casing. Take care during this operation, particularly in cold weather as it is all too easy to fill up the rocker cover before the oil drains down into the engine, with very messy results as it overflows out of the filler neck. Continue adding oil a small quantity at a time, until the level is up to the lower mark on the dipstick. Adding approximately 0.5 litres will raise the level to the upper mark on the dipstick.

**21** Start the engine. The oil pressure warning light will take a few seconds to go out while the new filter fills with oil; do not race the engine while the light is on. Run the engine for a few minutes, while checking for leaks around the oil filter seal and the drain plug.

**22** Switch off the engine, and wait a few minutes for the oil to settle in the transmission once more. With the new oil circulated and the filter now completely full, recheck the level on the dipstick, and add more oil as necessary.

**23** Dispose of the used engine oil safely and in accordance with environmental regulations (see "General repair procedures").

## 14 Front brake wear check



**Warning:** The dust created by wear of the shoes may contain asbestos, which is a health hazard. Never blow it out with compressed air, and don't inhale any of it. An approved filtering mask should be worn when working on the brakes. **DO NOT** use petrol or petroleum-based solvents to clean brake parts; use brake cleaner or methylated spirit only.

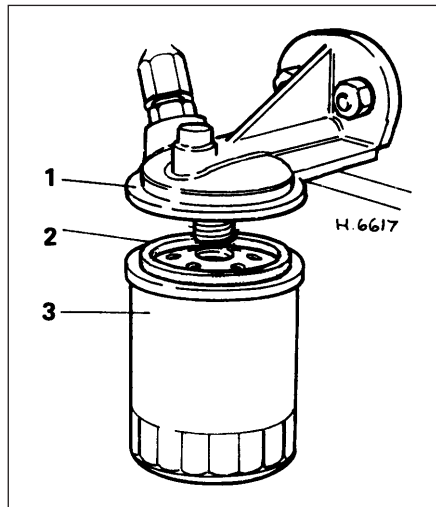

13.16 Canister type oil filter

- 1 Housing
- 2 Sealing ring
- 3 Filter

## Drum brake models

**1** After high mileage the friction linings on the brake shoes will have worn, and it will therefore be necessary to fit replacement shoes with new linings.

**2** Chock the rear wheels then jack up the front of the car and support it on axle stands (see "Jacking and vehicle support"). Remove the front roadwheels.

**3** Slacken off the brake shoe adjuster(s) from behind the backplate, and then undo and remove the two brake drum retaining screws.

**4** Remove the brake drum from the wheel hub. If the drum is tight, gently tap its circumference with a soft-faced mallet.

**5** Brush and wipe away all traces of asbestos dust from the brake shoes, wheel cylinders and backplate, and also from the inner circumference of the brake drum.

**6** Inspect the friction material and renew the brake shoes as described in Chapter 9 if they have worn down to less than the specified minimum thickness.

**7** The brake shoes must also be renewed if there is any sign of hydraulic fluid contamination of the linings due to a leaking brake wheel cylinder. If this is the case, the cause of the leak must be traced and rectified before fitting new brake shoes.

**8** Brake shoes should always be renewed as complete sets (four shoes to a set), otherwise uneven braking and pulling to one side may occur.

**9** It is advisable to check that the brake wheel cylinders are operating correctly before proceeding further. To do this hold the brake shoes in position using two screwdrivers while an assistant very slowly depresses the brake pedal slightly. Check that the wheel cylinder pistons move out as the pedal is depressed, and return when the pedal is released. If this is not the case, it is quite likely that one of the wheel cylinder pistons is seized and the cylinder should therefore be renewed (Chapter 9).

**10** Also check the condition of the brake drum, If it is deeply scored on its inner circumference it may be possible to have it skimmed at an engineering works. If the scoring is severe, renewal will be necessary

## Disc brake models

**11** Jack up the front or rear of the vehicle in turn, and support it on axle stands (see "Jacking and vehicle support").

**12** For better access to the brake calipers, remove the roadwheels.

**13** Look through the opening in the front of the caliper, and check that the thickness of the friction lining material on each of the pads is not less than the recommended minimum thickness given in the *Specifications* (see **Haynes Hint**). If any one of the brake pads has worn down to, or below, the specified limit, *all four* pads must be renewed as a set (ie all the front pads).

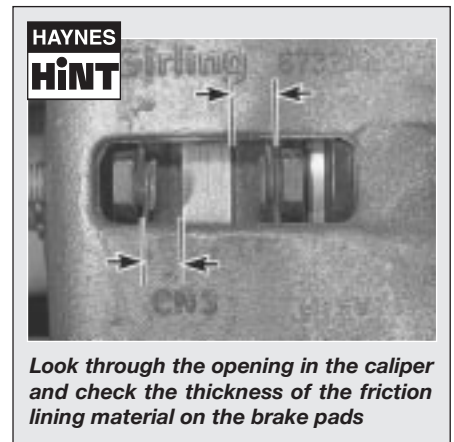

Look through the opening in the caliper and check the thickness of the friction lining material on the brake pads

**14** For a comprehensive check, the brake pads should be removed and cleaned. The operation of the brake calipers can then be checked, and the brake discs can be fully examined. Refer to Chapter 9 for details.

## 15 Driveshaft gaiter check



With the vehicle raised and securely supported on stands (see "Jacking and vehicle support"), turn the steering onto full lock, then slowly rotate the roadwheel. Inspect the condition of the outer constant velocity (CV) joint rubber gaiters, squeezing the gaiters to open out the folds. Check for signs of cracking, splits or deterioration of the rubber, which may allow the grease to escape, and lead to water and grit entry into the joint. Also check the security and condition of the retaining clips. Repeat these checks on the inner CV joints where offset sphere type joints are fitted. If any damage or deterioration is found, the gaiters should be renewed as described in Chapter 8.

At the same time, check the general condition of the CV joints themselves by first holding the



16.1a Lubricating the swivel hub upper grease nipple . . .

driveshaft and attempting to rotate the wheel. Repeat this check by holding the inner joint and attempting to rotate the driveshaft. Any appreciable movement indicates wear in the joints, wear in the driveshaft splines, or a loose driveshaft retaining nut.



16.1b . . . the upper suspension arm inner pivot grease nipple . . .

5 Although not actually part of the steering and suspension, the handbrake cable guides and the moving sectors on the rear subframe should be lubricated at this time to ensure smooth operation. There are no grease nipples, so the grease should be applied with a wooden spatula or similar tool to lubricate these areas thoroughly.



16.1c . . . and the rear radius arm pivot grease nipple

make sure the hose has not expanded and/or hardened where it slips over the fitting, allowing it to leak.

5 Check all fluid reservoirs, filler caps, drain plugs and fittings etc, looking for any signs of leakage of oil, transmission and/or brake hydraulic fluid or coolant. If the vehicle is regularly parked in the same place, close inspection of the ground underneath it will soon show any leaks. As soon as a leak is detected, its source must be traced and rectified. Where oil has been leaking for some time, it is usually necessary to use a steam cleaner, pressure washer or similar, to clean away the accumulated dirt, so that the exact source of the leak can be identified.

## 16 Steering and suspension lubrication



1 Unlike most modern cars, there are a number of steering and suspension joints on the Mini which require regular attention. Provision for lubrication of these joints is by means of a grease nipple, to which a grease gun can be engaged. The grease nipples are located in the following areas (see illustrations):

- a) *Steering swivel hub; two nipples, one upper and one lower on each side.*
- b) *Upper suspension arm inner pivot; one nipple on each arm.*
- c) *Rear radius arm pivot; one nipple on each pivot. Remove the rubber blanking plug to expose the nipple on early models.*

2 When lubricating the front grease nipples it is preferable to raise the front of the car and support it on axle stands (see "Jacking and vehicle support") so that the load is taken off the suspension. This will allow the grease to penetrate into the joints more effectively. The rear radius arm pivots can be lubricated with the car on its roadwheels if wished.

3 With the car raised and suitably supported, wipe clean the area all round the grease nipple and the nipple itself. Engage the head of a grease gun, filled with the specified grease, squarely onto the nipple, keeping it pushed fully home. Operate the gun until grease can be seen to appear from under the dust cover over the joint or from around the side of the pivot bushes.

4 When lubricating the rear radius arm pivots, a generous amount of grease will be needed each side, quite a bit more than was required for the front suspension joints. It probably won't be possible to tell when sufficient has been applied, unless you look underneath at the inner attachment on the subframe, it may be possible to see it appear around the inner pivot; add a bit more if in doubt. This is a vitally important area on the Mini and it must be well lubricated.

## 17 Rear brake wear check



The procedure for checking the rear brake components is the same as described in Section 14 for models with drum brakes.

## 18 Underbonnet check for fluid leaks and hose condition



### General

1 High temperatures in the engine compartment can cause the deterioration of the rubber and plastic hoses used for engine, accessory and emission systems operation. Periodic inspection should be made for cracks, loose clamps, material hardening and leaks.

2 Carefully check the large top and bottom radiator hoses, along with the other smaller-diameter cooling system hoses and metal pipes; do not forget the heater hoses/pipes which run from the engine to the bulkhead. Inspect each hose along its entire length, replacing any that are cracked, swollen or shows signs of deterioration. Cracks may become more apparent if the hose is squeezed (see Haynes Hint).

3 Make sure that all hose connections are tight. If the spring clamps that are used to secure some of the hoses appear to be slackening, they should be renewed to prevent the possibility of leaks.

4 Some other hoses are secured to their fittings with screw type clips. Where screw type clips are used, check to be sure they haven't slackened, allowing the hose to leak. If clamps or screw type clips aren't used,

### Vacuum hoses

6 It's quite common for vacuum hoses, especially those in the emissions system, to be numbered or colour-coded, or to be identified by coloured stripes moulded into them. Various systems require hoses with different wall thicknesses, collapse resistance and temperature resistance. When renewing hoses, be sure the new ones are made of the same material.

7 Often the only effective way to check a hose is to remove it completely from the vehicle. If more than one hose is removed, be sure to label the hoses and fittings to ensure correct installation.

8 When checking vacuum hoses, be sure to include any plastic T-fittings in the check.

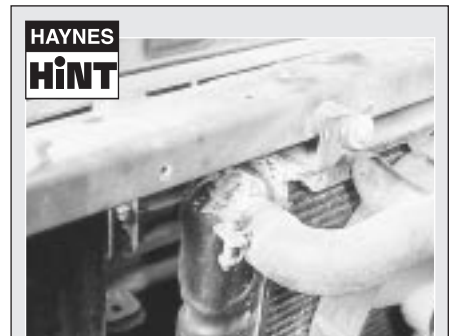

A leak in the cooling system will usually show up as white or rust coloured deposits on the area adjoining the leak



# 1•16 Every 6000 miles or 6 months

Inspect the fittings for cracks, and check the hose where it fits over the fitting for distortion, which could cause leakage.

**9** A small piece of vacuum hose can be used as a stethoscope to detect vacuum leaks. Hold one end of the hose to your ear, and probe around vacuum hoses and fittings, listening for the "hissing" sound characteristic of a vacuum leak.



**Warning:** When probing with the vacuum hose stethoscope, be very careful not to come into contact with moving engine components such as the fan or fan belt.

## Fuel hoses



**Warning:** Before carrying out the following operation, refer to the precautions given in "Safety first!" at the beginning of this manual, and follow them implicitly. Petrol is a highly dangerous and volatile liquid, and the precautions necessary when handling it cannot be overstressed.

**10** Check all fuel hoses for deterioration and chafing. Check especially for cracks in areas where the hose bends, and also just before fittings, such as where a hose attaches to the carburettor.

**11** Spring-type clamps are commonly used on fuel lines. These clamps often lose their tension over a period of time, and can be "sprung" during removal. Replace all spring-type clamps with screw clips whenever a hose is replaced.

## Metal lines

**12** Sections of metal piping are often used for fuel line between the fuel tank, filter and the engine. Check carefully to be sure the piping has not been bent or crimped, and that cracks have not started in the line.

**13** If a section of metal fuel line must be renewed, only seamless steel piping should be used, since copper and aluminium piping don't have the strength necessary to withstand normal engine vibration.

**14** Check the metal brake lines where they enter the master cylinder for cracks in the lines or loose fittings. Any sign of brake fluid leakage calls for an immediate and thorough inspection of the brake system.

## 19 Fuel system components, checks and lubrication



**1** Sparingly apply a few drops of light oil to the throttle spindles, accelerator cable and the pedal pivot. Similarly lubricate the exposed ends of the choke cable (where fitted).

**2** Check that there is a small amount of slackness in the cable so that the throttle linkage closes fully with the accelerator pedal released. Also check that full throttle can be obtained with the accelerator pedal fully depressed.

**3** If there is any doubt about the cable adjustment, refer to the relevant Parts of

Chapter 4 for the full adjustment procedure.

**4** On carburettor models, unscrew the piston damper cap from the top of the carburettor dashpot (see illustration). Top up the damper with engine oil until the level is 13.0 mm above the top of the hollow piston rod.

**5** Slowly push the damper back into the piston and screw on the cap taking care not to cross-thread it.

## 20 Contact breaker points check and adjustment



Refer to Chapter 5B.

## 21 Distributor lubrication



**1** It is important that the distributor cam is lightly lubricated with general purpose grease, and that the contact breaker arm, centrifugal advance weights and cam spindle are also very lightly lubricated.

**2** Great care should be taken not to use too much lubricant, as any excess that might find its way onto the contact breaker points could cause burning and misfiring.

**3** If an ignition shield is fitted over the front of the engine, release the three plastic retaining lugs and lift away the shield. Detach the two spring clips or undo the two screws securing the distributor cap to the distributor body and lift off the cap.

**4** To gain access to the cam spindle, lift away the rotor arm. Drop no more than two drops of



19.4 Top up the piston damper on carburettor models

engine oil onto the felt pad or screw head (see illustration). This will run down the spindle when the engine is hot and lubricate the bearings. The centrifugal advance weights can be lubricated by dropping two or three drops of engine oil through one of the holes or slots in the distributor baseplate. No more than one drop of oil should be applied to the contact breaker arm pivot post.

**5** Refit the rotor arm, distributor cap and ignition shield on completion.

## 22 Clutch return stop adjustment



**Note:** As friction linings of the clutch disc wear, the distance between the clutch release bearing and the clutch thrust plate will decrease. The pressure plate will then move in closer to the clutch disc to compensate for wear. Unless the wear is taken up by adjustment of the stop located between the flywheel housing and the

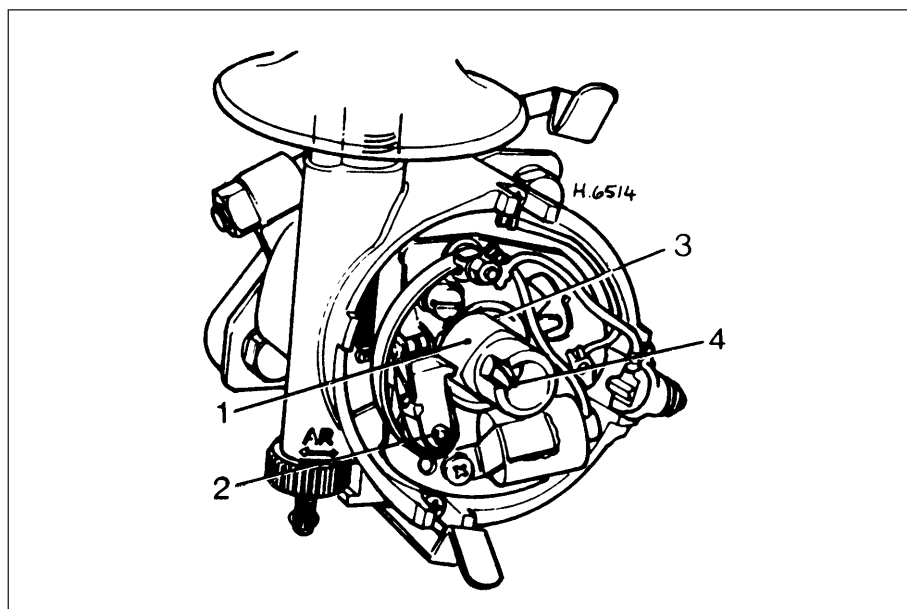

21.4 Distributor lubrication points

- 1 Contact breaker cam
- 2 Contact breaker pivot post

- 3 Centrifugal weights lubrication point
- 4 Cam spindle

operating lever, the clutch will start to slip. On later models fitted with the verto type clutch, the assembly is self-adjusting and the following procedure will not be necessary.

- 1 To carry out the adjustment, first disconnect the clutch operating lever return spring.
- 2 Pull the operating lever away from the engine until all the free play is eliminated.
- 3 Hold the lever in this position and measure the gap between the lever and the head of the stop using feeler blades (see illustration).
- 4 If necessary, slacken the locknut and adjust the stop bolt until the specified gap is achieved. Then tighten the locknut.



**22.3 Using feeler blades to measure the clutch return stop clearance**

as follows. Depress the footbrake four or five times to exhaust the vacuum, then start the engine. As the engine starts, there should be a noticeable "give" in the brake pedal as vacuum builds up. Allow the engine to run for at least two minutes, and then switch it off. If the brake pedal is now depressed again, it should be possible to detect a hiss from the servo as the pedal is depressed. After about four or five applications, no further hissing should be heard, and the pedal should feel considerably harder.

## Steering and suspension

- 5 Check for any abnormalities in the steering, suspension, handling or road "feel".
- 6 Drive the vehicle, and check that there are no unusual vibrations or noises.
- 7 Check that the steering feels positive, with no excessive sloppiness or roughness, and check for any suspension noises when cornering and driving over bumps.

## Drivetrain

- 8 Check the performance of the engine, transmission and driveline.
- 9 Check that the engine starts correctly, both when cold and when hot.
- 10 Listen for any unusual noises from the engine and transmission.
- 11 Make sure that the engine runs smoothly when idling, and that there is no hesitation when accelerating.
- 12 On manual transmission models, check that all gears can be engaged smoothly without noise, and that the gear lever action is not abnormally vague or "notchy".
- 13 On automatic transmission models, make sure that the drive seems smooth without jerks or engine speed "flare-ups". Check that all the gear positions can be selected with the vehicle at rest.

## Clutch

- 14 Check that the clutch pedal moves smoothly and easily through its full travel, and that the clutch itself functions correctly, with no trace of slip or drag. If the movement is uneven or stiff in places, check the system components with reference to Chapter 6.

## Instruments and electrical equipment

- 15 Check the operation of all instruments and electrical equipment.
- 16 Make sure that all instruments read correctly, and switch on all electrical equipment in turn, to check that it functions properly.
- 17 Test the operation of the brake failure warning system (where fitted) by pressing the test switch located next to the heated rear window switch. When pressed, the switch should light and go out when released.
- 18 If the light should come on when driving, the brake fluid level should be checked (and topped up, if necessary), as soon as possible.

## 23 Dynamo check and lubrication



Dynamo checks and lubrication consist simply of checking the fan belt condition and tension (Section 8) and adding a few drops of engine oil to the dynamo rear bearing lubricating hole.

## 24 Control box cleaning and inspection



On dynamo equipped models, remove the control box cover and check the cut-out and regulator contacts. If they are dirty or rough or burnt, place a piece of fine glasspaper (do not use emery paper or carborundum paper) between the cut-out contacts, close them manually, and draw the glasspaper through several times.

Clean the regulator contacts in exactly the same way, but use emery or carborundum paper and not glasspaper. Carefully clean both sets of contacts from all traces of dust with a rag moistened in methylated spirit. Refit the cover on completion.

## 25 Ignition timing check and adjustment



Refer to Chapter 5B.

## 26 Carburettor idle speed and mixture adjustment



Refer to Chapter 4A.

## 27 Door, boot and bonnet check and lubrication



- 1 Check that the doors, bonnet and boot lid close securely. Check that the bonnet safety

catch operates correctly. Check the operation of the door check straps.

- 2 Lubricate the hinges, door check straps, the striker plates and the bonnet catch sparingly with a little oil or grease.
- 3 If any of the doors, bonnet or boot lid do not close effectively or appear not to be flush with the surrounding panels, carry out the adjustment procedures contained in Chapter 11.

## 28 Bodywork, paint and exterior trim check



- 1 The best time to carry out this check is after the car has been washed so that any surface blemish or scratch will be clearly evident and not hidden by a film of dirt.
- 2 Starting at one front corner check the paintwork all around the car, looking for minor scratches or more serious dents. Check all the trim and make sure that it is securely attached over its entire length.
- 3 Check the security of all door locks, door mirrors, badges, bumpers, front grille and wheel trim. Anything found loose, or in need of further attention should be done with reference to the relevant Chapters of this manual.
- 4 Rectify any problems noticed with the paintwork or body panels (see Chapter 11).

## 29 Road test



### Check the operation and performance of the braking system

- 1 Make sure that the vehicle does not pull to one side when braking, and that the wheels do not lock when braking hard.
- 2 Check that there is no vibration through the steering when braking.
- 3 Check that the handbrake operates correctly, without excessive movement of the lever, and that it holds the vehicle stationary on a slope.
- 4 With the engine switched off, test the operation of the brake servo unit (where fitted)

30 Air cleaner element renewal



**Carburettor models except Cooper S**

**1** On models with an air intake duct over the top of the engine, unscrew the two nuts securing the duct to the rocker cover studs. Release the clip and disconnect the duct from the air cleaner body.

**2** Undo and remove the single wing nut and washer on early models, or the twin wing bolts and washers on later models, securing the air cleaner to the carburettor

**3** If the air cleaner is retained by a single wing nut lift off the air cleaner top cover. Detach the rocker cover hose, then lift the air cleaner body off the carburettor, tip it up at the front and slide it sideways until it is clear of the long retaining stud and can be lifted away. Recover the sealing ring.

**4** If the air cleaner is retained by two wing nuts, detach the hot air duct (where fitted) and then lift the air cleaner body off the carburettor.

**5** With the air cleaner removed from the engine, recover the rubber sealing ring if it stayed behind on the carburettor flange.

**6** Lift off the air cleaner cover and withdraw the paper element. On the later type moulded plastic air cleaners the cover is removed by prising it off with a screwdriver inserted in the slots on the periphery of the cover (see illustrations).

**7** Thoroughly clean the inside of the air cleaner body.

**8** Refit the air cleaner and element using a reverse of the removal procedure. Make sure that where an alignment arrow is stamped on the top cover, it is pointing toward the location lug on the air cleaner body (see illustration). Ensure also that the rubber sealing ring is in position before refitting the air cleaner.

**9** If the air cleaner body incorporates an adjustable air intake spout, this should be positioned adjacent to the exhaust manifold in winter and away from it in summer.



30.6a Prise off the later type air cleaner moulded plastic cover . . .



30.6b . . . and lift out the element

**Cooper S carburettor models**

**10** Undo and remove the two wing bolts and washers and lift off the air cleaner top cover. Lift out the paper elements and thoroughly clean the inside of the air cleaner body.

**11** The air cleaner body may be removed if necessary after disconnecting the engine breather pipe and the throttle return spring. Take care not to lose the two rubber sealing washers from the carburettor flanges.

**12** Refitting the air cleaner and elements is the reverse of the removal procedure.

**Fuel injection models**

**13** Release the four retaining clips, then slacken and remove the three screws securing the air cleaner assembly to the throttle body, and lift off the air cleaner lid. Remove the filter element (see illustrations).

**14** Wipe the body of the air cleaner clean, then fit the new element, ensuring that it is correctly seated.

**15** Refit the air cleaner lid, and secure it in position with the retaining screws (tightening them securely) and clips.

31 Valve clearance adjustment



Refer to Chapter 2A.

32 Distributor cap, rotor arm and HT lead check



**Warning:** Voltages produced by an electronic ignition system are considerably higher than those produced by conventional ignition systems. Extreme care must be taken when working on the system if the ignition is switched on. Persons with surgically-implanted cardiac pacemaker devices should keep well clear of the ignition circuits, components and test equipment.

**1** The spark plug (HT) leads should be inspected one at a time, to prevent mixing up the firing order, which is essential for proper engine operation. Gain access to the leads and disconnect them as described for the spark plug check and renewal.

**2** Check inside the boot for corrosion, which will look like a white crusty powder. Clean this off as much as possible; if it is excessive, or if cleaning leaves the metal connector too badly corroded to be fit for further use, the lead must be renewed. Push the lead and boot back onto the end of the spark plug - if it doesn't, remove the lead and use pliers carefully to crimp the metal connector inside the boot until the fit is snug.

**3** Using a clean rag, wipe the entire length of the lead to remove built-up dirt and grease.



30.8 Make sure the alignment arrow is toward the lug on the air cleaner body



30.13a On fuel injection models, release the clips (three arrowed) and remove the screws



30.13b Lift off the lid and remove the element



Once the lead is clean, check for burns, cracks and other damage. Do not bend the lead sharply, because the conductor might break.

**4** Inspect the remaining spark plug (HT) leads, ensuring that each is securely fastened at the distributor cap and spark plug when the check is complete. If any sign of arcing, severe connector corrosion, burns, cracks or other damage is noticed, obtain new spark plug (HT) leads, renewing them as a set.



**If new spark plug leads are to be fitted, remove the leads one at a time and fit each new lead in exactly the same position as the old one.**

**5** Spring back the retaining clips or undo the two screws and remove the distributor cap. Thoroughly clean it inside and out with a dry lint-free rag.

**6** Examine the HT lead segments inside the cap. If they appear badly burned or pitted renew the cap. Also check the carbon brush in the centre of the cap, ensuring that it is free to move and stands proud of its holder. Make sure that there are no signs of cracks or black "tracking" lines running down the inside of the cap, which will also mean renewal if evident.

**7** Inspect the rotor arm checking it for security and also for signs of deterioration as described above.

**8** Refit the distributor cap on completion.

## 33 Spark plug renewal



**1** It is vital for the correct running, full performance and proper economy of the engine that the spark plugs perform with maximum efficiency. The most important factor in ensuring this, is that the plugs fitted are appropriate for the engine (a suitable type is specified at the end of this Chapter). If this type is used and the engine is in good condition, the spark plugs should not need attention between scheduled renewal intervals. Spark plug cleaning is rarely

necessary, and should not be attempted unless specialised equipment is available, as damage can easily be caused to the firing ends.

**2** Spark plug removal and refitting requires a spark plug socket, with an extension which can be turned by a ratchet handle or similar. This socket is lined with a rubber sleeve, to protect the porcelain insulator of the spark plug, and to hold the plug while you insert it into the spark plug hole. You will also need a wire-type feeler gauge, to check and adjust the spark plug electrode gap, and a torque wrench to tighten the new plugs to the specified torque.

**3** To remove the spark plugs, open the bonnet, where fitted, release the three plastic retaining lugs and lift the ignition shield off the front of the engine

**4** If the marks on the original-equipment HT leads cannot be seen, mark the leads 1 to 4, to correspond to the cylinder the lead serves.

**5** Pull the leads from the plugs by gripping the rubber boot, not the lead, otherwise the lead connection may be fractured (see illustration).

**6** Unscrew the spark plugs, ensuring that the socket is kept in alignment with each plug - if the socket is forcibly moved to either side, the porcelain top of the plug may be broken off. If any undue difficulty is encountered when unscrewing any of the spark plugs, carefully check the cylinder head threads and sealing surfaces for signs of wear, excessive corrosion or damage; if any of these conditions is found, seek the advice of a dealer as to the best method of repair.

**7** As each plug is removed, examine it as follows - this will give a good indication of the condition of the engine. If the insulator nose of the spark plug is clean and white, with no deposits, this is indicative of a weak mixture.

**8** If the tip and insulator nose are covered with hard black-looking deposits, then this is indicative that the mixture is too rich. Should the plug be black and oily, then it is likely that the engine is fairly worn, as well as the mixture being too rich.

**9** If the insulator nose is covered with light tan to greyish-brown deposits, then the mixture is

correct, and it is likely that the engine is in good condition.

**10** The spark plug electrode gap is of considerable importance as, if it is too large or too small, the size of the spark and its efficiency will be seriously impaired. The gap should be set to the value given in the *Specifications*.

**11** To set the electrode gap, measure the gap with a feeler blade or adjusting tool, and then bend open, or closed, the outer plug electrode until the correct gap is achieved (see illustration). The centre electrode should never be bent, as this may crack the insulation and cause plug failure, if nothing worse. If the outer electrode is not exactly over the centre electrode, bend it gently to align them.

**12** Before fitting the spark plugs, check that the threaded connector sleeves at the top of the plugs are tight, and that the plug exterior surfaces and threads are clean (see *Haynes Hint*).

**13** On installing the spark plugs, first check that the cylinder head thread and sealing surface are as clean as possible; use a clean rag wrapped around a paintbrush to wipe clean the sealing surface. Ensure that the spark plug threads are clean and dry then screw them in by hand where possible. Take extra care to enter the plug threads correctly.

**14** When each spark plug is started correctly on its threads, screw it down until it just seats lightly, then tighten it to the specified torque wrench setting.

**15** Reconnect the HT leads in their correct order, using a twisting motion on the boot until it is firmly seated. Finally, refit the ignition shield.



**33.5** Pull the leads off the spark plugs by gripping the rubber boot



**33.11** Adjusting a spark plug electrode gap



*It is very often difficult to insert spark plugs into their holes without cross-threading them. To avoid this possibility, fit a short length of 5/16 inch internal diameter rubber hose over the end of the spark plug. The flexible hose acts as a universal joint to help align the plug with the plug hole. Should the plug begin to cross-thread, the hose will slip on the spark plug, preventing thread damage to the aluminium cylinder head*

# 1•20 Every 12 000 miles or 12 months

## 34 Emission control equipment check



1 Of the emission control systems that may be fitted, only the air pump drivebelt (where

applicable), the crankcase ventilation system and the evaporative emission control systems require regular checking, and even then, the components of these systems require minimal attention.

2 Checks and adjustment of the air pump drivebelt are contained in Section 9.

3 The crankcase ventilation system filter in

the oil filler cap should be renewed by simply renewing the cap (the new cap is supplied with filter inside). Checks of the other system components are contained in Chapter 4C.

4 Should it be felt that the other systems are not functioning correctly, the advice of a dealer should be sought.

# Every 24 000 miles or 24 months

## 35 Coolant renewal



**Warning:** Wait until the engine is cold before starting this procedure. Do not allow antifreeze to come into contact with your skin, or with painted surfaces of the vehicle. Rinse off spills immediately with plenty of water. Never leave antifreeze lying around in an open container, or in a puddle in the driveway or on the garage floor. Children and pets are attracted by its sweet smell, but antifreeze can be fatal if ingested.

**Note:** If coolant to Rover specification, in the correct ratio, has been continuously maintained in the system, then coolant renewal will not normally be necessary. However, to be absolutely sure about the integrity of the antifreeze and anti-corrosion properties of the coolant, periodic renewal is to be recommended.

### Cooling system draining

1 To drain the system, first remove the expansion tank filler cap (see "Weekly checks"). Move the heater temperature control to the hot position.

2 If there is anti-freeze in the system, place clean bowls beneath the radiator and at the rear of the engine to collect the coolant for re-use.

3 Undo and remove the radiator drain plug and cylinder block drain plug, and allow the coolant to drain. If fitted, the radiator drain plug is located at the bottom of the radiator nearest the grille, and the cylinder block drain plug (if fitted) can be found at the rear of the block, beneath the engine tie-bar (see illustration).

4 On later models the radiator does not incorporate a drain plug, and it is therefore necessary to detach the bottom hose to drain the coolant. To do this slacken the bottom hose retaining clip and pull the hose off the radiator outlet. The hose clip is very inaccessible and a long thin screwdriver is quite useful here. If the hose proves difficult to remove from the radiator outlet, it is possible to gently push it off from the access hole under the wheel arch.

5 When the coolant has stopped running, probe the orifices, particularly the cylinder block orifice, with a short piece of wire to dislodge any particles of rust or sediment which may be preventing the coolant from completely draining out.

### Cooling system flushing

6 With time, the cooling system may

gradually lose its efficiency if the radiator core becomes choked with rust, scale deposits from the water, and other sediment. This is especially likely if an inferior grade of antifreeze has been used that has not been regularly renewed. To minimise this, as well as using only the specified type of antifreeze and clean soft water, the system should be flushed as follows whenever any part of it is disturbed, and/or when the coolant is renewed.

7 With the coolant drained, close the drain taps and refill the system with fresh water. Refit the radiator cap, start the engine and warm it up to normal operating temperature, then stop it and (after allowing it to cool down completely) drain the system again. Repeat as necessary until only clean water can be seen to emerge, then refill finally with the specified coolant mixture.

8 If only clean, soft water and good-quality antifreeze has been used, and the coolant has been renewed at the specified intervals, the above procedure will be sufficient to keep the system clean for a considerable length of time. If, however, the system has been neglected, a more thorough operation will be required, as follows.

9 To flush the system first drain the coolant as described in the previous Section. Place a garden hose in the radiator filler cap neck and allow water to run through the system for ten to fifteen minutes.

10 To flush the engine, remove the thermostat (see Chapter 3), insert the garden hose into the thermostat housing, and allow water to circulate until it runs clear from the bottom hose. If, after a reasonable period, the water still does not run clear, the radiator should be flushed with a good proprietary cleaning agent.

11 In severe cases of contamination, reverse-flushing of the radiator may be necessary. To do this, remove the radiator (see Chapter 3), invert it, and insert the garden hose into the bottom outlet. Continue flushing until clear water runs from the top hose outlet. A similar procedure can be used to flush the heater matrix.

12 The use of chemical cleaners should be necessary only as a last resort. Normally, regular renewal of the coolant will prevent excessive contamination of the system.

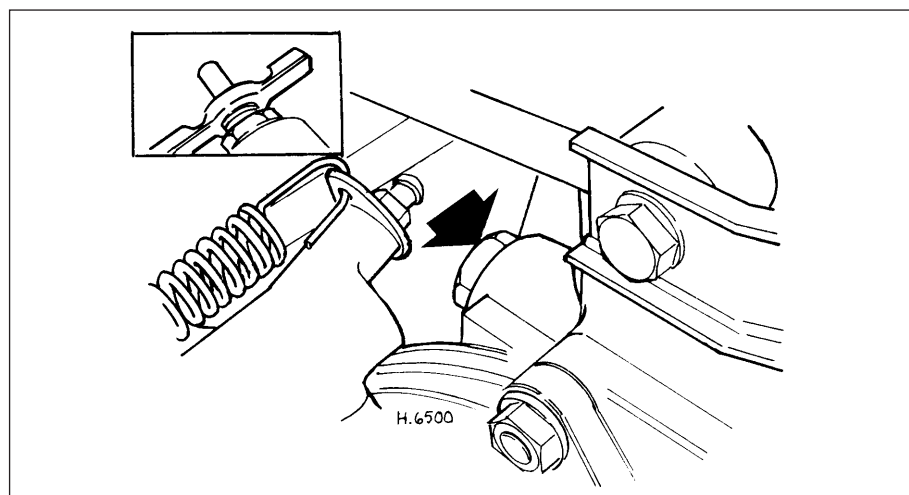

35.3 Cylinder block coolant drain tap or plug location (arrowed)

### Cooling system filling

**13** Refit the cylinder block and radiator drain plugs or bottom hose connection as applicable.

**14** Prepare a sufficient quantity of coolant mixture (water and antifreeze), in the specified concentration, to allow for a surplus, so as to have a reserve supply for topping-up. **Note:** On models with no cylinder block drain plug, it is not possible to fully drain the coolant. To establish a suitable antifreeze concentration it will be necessary to pour adequate antifreeze directly into the radiator and then top-up with water. Subsequent topping-up should be done with an antifreeze/water mixture.

**15** Set the heater control knob to the maximum heat position and then fill the cooling system slowly. Slow filling reduces the possibility of air being trapped and forming air-locks. It helps also, if the large radiator hoses are gently squeezed during the filling procedure.

**16** Do not fill the system higher than within 12 mm of the filler orifice. Overfilling will merely result in coolant loss down the overflow pipe due to expansion.

**17** When the system is full, refit the filler cap and turn it firmly clockwise to lock it in position. Start the engine and run it at idle speed, until it has warmed-up to normal operating temperature.

**18** Stop the engine, allow it to cool down completely (overnight, if possible), then remove the radiator filler cap and top-up if necessary. Refit the filler cap, tightening it securely, and wash off any spilt coolant from the engine compartment and bodywork.

**19** After refilling, always check carefully all components of the system (but especially any unions disturbed during draining and flushing) for signs of coolant leaks. Fresh antifreeze has a searching action, which will rapidly expose any weak points in the system.

### 36 Brake fluid renewal



**Warning:** Brake hydraulic fluid can harm your eyes and damage painted surfaces, so use extreme caution when handling and pouring it. Do not use fluid that has been standing open for some time as it absorbs moisture from the air. Excess moisture can cause a dangerous loss of braking effectiveness.

The procedure is similar to that for the bleeding of the hydraulic system as described in Chapter 9, except that the brake fluid reservoir should be emptied by siphoning, and allowance should be made for the old fluid to be removed from the circuit when bleeding a section of the circuit.



**Old hydraulic fluid is invariably much darker in colour than the new, making it easy to distinguish between the two.**

### 37 Fuel filter renewal (fuel injection models)



**Warning:** Before carrying out the following operation, refer to the precautions given in "Safety first!" at the beginning of this manual, and follow them implicitly. Petrol is a highly dangerous and volatile liquid, and the precautions necessary when handling it cannot be overstressed.

**1** Disconnect the battery negative lead.  
**2** Chock the front wheels then jack up the rear of the car and support it on axle stands (see "Jacking and vehicle support").

**3** To minimise fuel loss during the following operation, working inside the luggage compartment, remove the top stud, then pivot the fuel tank trim panel downwards and fit a hose clamp to the fuel tank feed hose.

**4** Refer to the information on fuel system depressurisation contained in Chapter 4B, Section 6.

**5** From underneath the vehicle, slacken the union nuts and disconnect the inlet and outlet pipes from the fuel filter, whilst retaining the union adapter/filter with an open-ended spanner (see illustrations).

**6** Remove the two bolts securing the filter mounting bracket to the subframe, and remove the filter assembly from the car.

**7** Slacken and remove the outlet pipe adapter and O-ring from the filter, then slacken the clamp bolt and slide the filter out of the mounting bracket, noting which way the arrow stamped on the filter is pointing.

**8** Remove the plugs from the filter, then fit the outlet pipe adapter (using a new O-ring), and tighten it securely. Ensuring that the arrow is pointing in the direction of the flow of fuel, slide the filter into position in the mounting bracket, and securely tighten the clamp bolt.

**9** Refit the filter assembly to the car, tightening its mounting bolts securely.

**10** Refit the inlet and outlet pipes to the filter, and securely tighten their union nuts.

**11** Lower the car to the ground, then remove the clamp from the fuel tank feed hose, and secure the trim panel in position with its retaining stud. Reconnect the battery, then start the engine and check the filter unions for leakage.



**Warning:** Dispose of the old filter safely; it will be highly flammable and may explode if thrown on a fire.

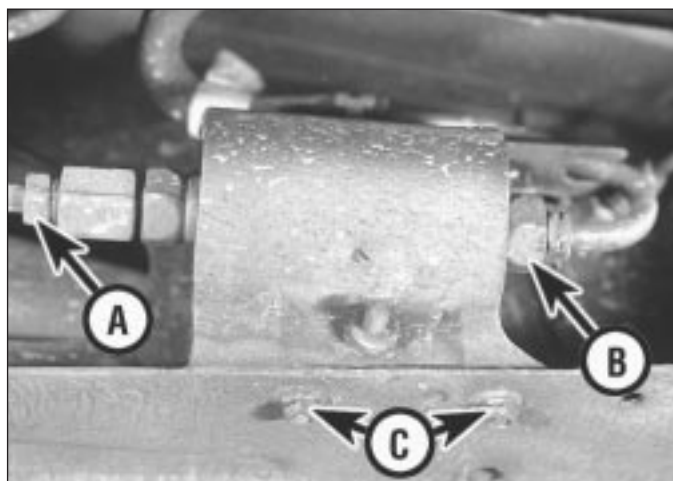

37.5a Fuel filter inlet union "A", outlet union "B" and mounting bracket retaining bolts "C"



37.5b Slacken the union nuts whilst retaining the union adapter/filter with an open-ended spanner



# Chapter 2 Part A: Engine in-car repair procedures

## Contents

Compression test - description and interpretation . . . . .	2	Oil cooler - removal and refitting . . . . .	16
Crankshaft oil seals - renewal . . . . .	9	Oil filter housing and delivery pipe - removal and refitting . . . . .	15
Cylinder head (carburettor engines) - removal and refitting . . . . .	7	Oil pressure relief valve - removal, inspection and refitting . . . . .	14
Cylinder head (fuel injection engines) - removal and refitting . . . . .	8	Rocker shaft assembly - removal, inspection and refitting . . . . .	6
Distributor driveshaft - removal and refitting . . . . .	13	Timing chain, tensioner and sprockets - removal, inspection and refitting . . . . .	5
Engine oil and filter renewal . . . . .	See Chapter 1	Top Dead Centre (TDC) for number one piston - locating . . . . .	3
Engine oil level check . . . . .	See "Weekly Checks"	Torque converter (automatic transmission models) - removal and refitting . . . . .	11
Engine/transmission mountings - renewal . . . . .	12	Valve clearances - adjustment . . . . .	4
Flywheel (manual transmission models) - removal and refitting . . . . .	10		
General information . . . . .	1		

## Degrees of difficulty

<b>Easy</b> , suitable for novice with little experience 	<b>Fairly easy</b> , suitable for beginner with some experience 	<b>Fairly difficult</b> , suitable for competent DIY mechanic 	<b>Difficult</b> , suitable for experienced DIY mechanic 	<b>Very difficult</b> , suitable for expert DIY or professional 
---	--	--	---	--

## Specifications

### Engine general

#### Code and displacement:

85H . . . . .	848 cc
99H . . . . .	998 cc
10H . . . . .	1098 cc
12H . . . . .	1275 cc
12A . . . . .	1275 cc

#### Bore:

85H . . . . .	62.94 mm
99H . . . . .	64.59 mm
10H . . . . .	64.59 mm
12H . . . . .	70.61 mm
12A . . . . .	70.61 mm

#### Stroke:

85H . . . . .	68.25 mm
99H . . . . .	76.20 mm
10H . . . . .	83.72 mm
12H . . . . .	81.28 mm
12A . . . . .	81.28 mm

#### Compression ratio:

85H . . . . .	8.3:1
99H:	
Pre-1983 manual transmission models . . . . .	8.3:1
1983 to 1987 manual transmission models . . . . .	10.3:1
Automatic transmission models . . . . .	8.9:1
1988-on (category C) . . . . .	9.6:1
1989-on (low compression) . . . . .	8.3:1
1989-on (high compression) . . . . .	9.6:1
10H . . . . .	8.5:1
12H:	
1275 GT models . . . . .	8.8:1
Cooper S Mk III models . . . . .	9.75:1
12A:	
Cooper models . . . . .	10.0:1
All other models . . . . .	9.4:1

#### Direction of crankshaft rotation

Clockwise (viewed from left-hand side of vehicle)

#### Firing order

1-3-4-2 (No 1 cylinder next to radiator)

### Valve clearances

Inlet and exhaust (engine cold):

All engine types except 12A .....	0.30 mm
12A engines .....	0.33 to 0.38 mm

### Torque wrench settings

	Nm	lbf ft
Cylinder head nuts .....	68	50
Rocker shaft pedestal nuts .....	32	24
Crankshaft pulley bolt .....	102	75
Camshaft nut .....	88	65
Torque converter centre bolt .....	152	112
Torque converter (six central bolts) .....	29	21
Timing cover and front plate:		
$\frac{1}{4}$ in UNF bolts .....	7	5
$\frac{5}{16}$ in UNF bolts .....	16	12
Rocker cover .....	4.7	3.5
Engine mountings:		
$\frac{3}{4}$ in UNC bolts .....	40	30
M8 bolts .....	30	22
M10 bolts .....	45	33
M12 bolts .....	72	53

## 1 General information

### How to use this Chapter

This Part of Chapter 2 describes those repair procedures that can reasonably be carried out on the engine while it remains in the car. If the engine has been removed from the car and is being dismantled as described in Part B, any preliminary dismantling procedures can be ignored.

Part B describes the removal of the engine/transmission from the vehicle, and the full overhaul procedures that can then be carried out.

### Engine description

The Mini engine is a four-cylinder, water-cooled, overhead valve type of 848, 998, 1098, or 1275 cc displacement, depending on model and year of manufacture. The engine is bolted to the transmission assembly, which also forms the engine sump, and the complete power unit is supported, via rubber mountings, in the front subframe.

The cast iron cylinder head contains two valves per cylinder, mounted vertically and running in pressed-in valve guides. The valves are operated by rocker arms and pushrods via tubular cam followers from the camshaft, located in the left-hand side of the cylinder block.

The inlet and exhaust manifolds are attached to the left-hand side of the cylinder head and are linked to the valves via five inlet and exhaust ports of siamese configuration.

The pistons are of anodised aluminium alloy with three compression rings and an oil control ring on all engines except later 1275 cc units. These engines only have two compression rings. The gudgeon pin is retained in the small-end of the connecting rod by a pinch-bolt on 848 cc engines, by circlips on 1098 cc and early 998 cc engines and by an interference fit

in the connecting rod small-end bore on 1275 cc and later 998 cc engines. At the other end of the connecting rod, renewable big-end shell bearings are fitted.

At the front of the engine, a single row chain drives the camshaft via the camshaft and crankshaft sprockets. On 1275 cc Cooper S models a duplex (twin row) timing chain is fitted. On the 848 cc engine, the camshaft is supported by three bearings, two being bored directly in the cylinder block while a white metal bearing (which is renewable) is fitted at the timing chain end. On the 998 cc, 1098 cc and 1275 cc units three steel-backed metal camshaft bearings are fitted.

The statically and dynamically balanced forged steel crankshaft is supported by three renewable shell type main bearings. Crankshaft endfloat is controlled by four semi-circular thrustwashers located in pairs on either side of the centre main bearing.

A forced feed system of lubrication is used, with oil circulated round the engine from the transmission casing/sump. The level of engine oil in the sump is indicated on the dipstick, which is fitted on the right-hand side of the engine. The oil in the transmission casing/sump is also used to lubricate the transmission and differential.

The oil pump is mounted at the end of the cylinder block and is driven by the camshaft.

Oil is drawn from the sump through a gauze screen in the oil strainer and is sucked up the pick-up pipe and drawn into the oil pump. From the oil pump it is forced under pressure along a gallery on the right-hand side of the engine, and through drillings to the big-end, main and camshaft bearings. A small hole in each connecting rod allows a jet of oil to lubricate the cylinder wall with each revolution.

From the camshaft front bearing, oil is fed through drilled passages in the cylinder block and head to the front rocker pedestal where it enters the hollow rocker shaft. Holes drilled in the shaft allow for the lubrication of the rocker arms, and the valve stems and pushrod ends.

This oil is at a reduced pressure to the oil delivered to the crankshaft bearings. Oil from the front camshaft bearing also lubricates the timing chain. Oil returns to the sump by various passages the tappets being lubricated by oil returning via the pushrod drillings in the block.

On all models a full-flow oil filter is fitted, and all oil passes through this filter before it reaches the main oil gallery. The oil is passed directly from the oil pump across the block to an external pipe on the right-hand side of the engine which feeds into the filter head. Cooper S and certain later 1275 cc models are fitted with an oil cooler.

The water pump and fan are driven together with the dynamo or alternator by a V-belt from the crankshaft pulley.

Both the distributor and oil pump are driven off the camshaft: the distributor via skew gears on the right-hand side, and the oil pump via a slotted drive or splined coupling from the rear.

### Repair operations possible with the engine in the car

The following work can be carried out with the engine in the car:

- Compression pressure - testing.
- Valve clearances - adjustment.
- Timing chain, tensioner and sprockets - removal and refitting.
- Rocker shaft assembly - removal and refitting.
- Cylinder head and valve gear - removal and refitting.
- Cylinder head and pistons - decarbonising.
- Crankshaft oil seals - renewal.
- Flywheel/torque converter - removal and refitting.
- Engine mountings - renewal.
- Oil pressure relief valve - removal, inspection and refitting.
- Oil filter housing and delivery pipe - removal and refitting.
- Oil cooler - removal and refitting.

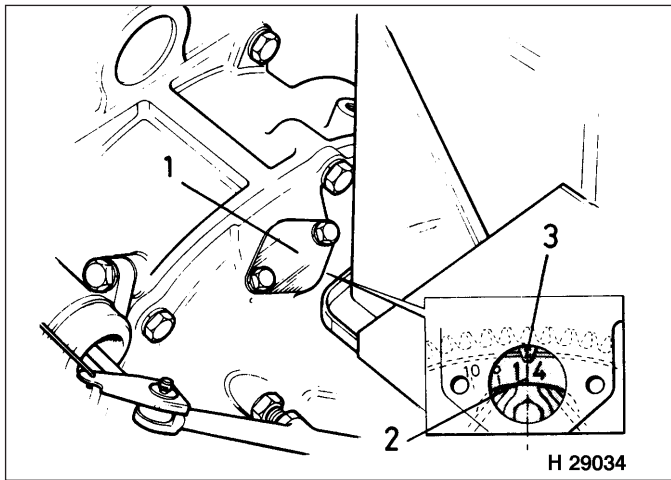

**3.4a Timing mark locations - early manual transmission models**

- 1 Inspection cover    2 Timing marks    3 Pointer

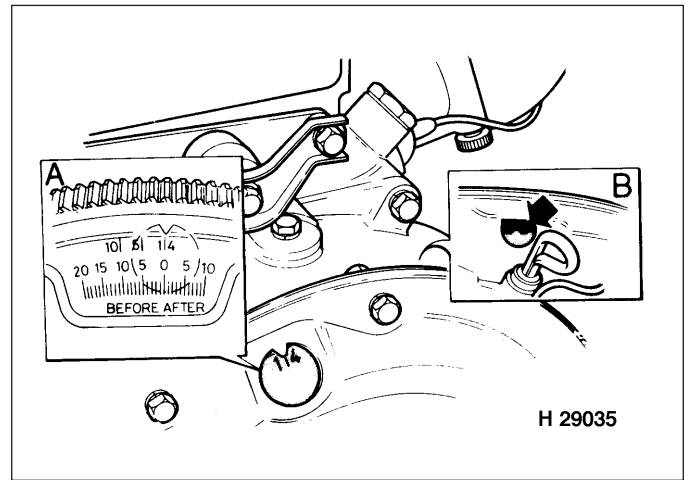

**3.4b Timing mark locations - automatic transmission models**

- A Detail showing alternative timing marks    B Insert screwdriver to turn torque converter

## 2 Compression test - description and interpretation



**1** When engine performance is down, or if misfiring occurs which cannot be attributed to the ignition or fuel systems, a compression test can provide diagnostic clues as to the engine's condition. If the test is performed regularly, it can give warning of trouble before any other symptoms become apparent.

**2** The engine must be fully warmed-up to normal operating temperature, the battery must be fully charged, and all the spark plugs must be removed (Chapter 1). The aid of an assistant will also be required.

**3** Disable the ignition system by disconnecting the ignition coil HT lead from the distributor cap and earthing it on the cylinder block. Use a jumper lead or similar wire to make a good connection.

**4** Fit a compression tester to the No 1 cylinder spark plug hole - the type of tester which screws into the plug thread is to be preferred.

**5** Have the assistant hold the throttle wide open, and crank the engine on the starter motor; after one or two revolutions, the compression pressure should build up to a maximum figure, and then stabilise. Record the highest reading obtained.

**6** Repeat the test on the remaining cylinders, recording the pressure in each.

**7** All cylinders should produce very similar pressures; a difference of more than 2 bars between any two cylinders indicates a fault. Note that the compression should build up quickly in a healthy engine; low compression on the first stroke, followed by gradually-increasing pressure on successive strokes, indicates worn piston rings. A low compression reading on the first stroke, which does not build up during successive strokes,

indicates leaking valves or a blown head gasket (a cracked head could also be the cause). Deposits on the undersides of the valve heads can also cause low compression.

**8** If the pressure in any cylinder is low, carry out the following test to isolate the cause. Introduce a teaspoonful of clean oil into that cylinder through its spark plug hole, and repeat the test.

**9** If the addition of oil temporarily improves the compression pressure, this indicates that bore or piston wear is responsible for the pressure loss. No improvement suggests that leaking or burnt valves, or a blown head gasket, may be to blame.

**10** A low reading from two adjacent cylinders is almost certainly due to the head gasket having blown between them; the presence of coolant in the engine oil will confirm this.

**11** If one cylinder is about 20 percent lower than the others and the engine has a slightly rough idle, a worn camshaft lobe could be the cause.

**12** If the compression reading is unusually high, the combustion chambers are probably coated with carbon deposits. If this is the case, the cylinder head should be removed and decarbonised.

**13** On completion of the test, refit the spark plugs and reconnect the ignition coil HT lead.

## 3 Top Dead Centre (TDC) for number one piston - locating



**2A**

**1** Top dead centre (TDC) is the highest point in the cylinder that each piston reaches as the crankshaft turns. Each piston reaches its TDC position at the end of its compression stroke and then again at the end of its exhaust stroke. For the purpose of engine timing, TDC refers to the position of No 1 piston at the end of its compression stroke. On the engines covered by this manual, No 1 piston is at the timing chain end of the engine. It is necessary to set the engine in this position when carrying out many of the operations in this Chapter. To do so, proceed as follows.

**2** Where fitted, release the three plastic retaining lugs and lift the ignition shield off the front of the engine.

**3** Spring back the two distributor cap retaining clips or undo the screws then place the distributor cap to one side.

**4** Gain access to the ignition timing marks by undoing the two bolts securing the inspection plate to the top of the flywheel housing and lifting off the plate. On automatic transmission models, withdraw the rubber grommet from the top of the converter housing (**see illustrations**). On later models there is a timing scale on the timing cover, together with a notch or pointer on the crankshaft pulley (**see illustration**).

**5** Turn the engine over until No 1 piston is approaching TDC on the compression stroke.

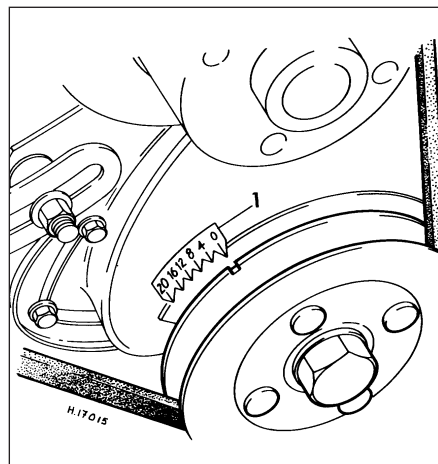

**3.4c Timing scale on timing cover of later manual transmission models**



## 2A•4 Engine in-car repair procedures

This can be checked by removing No 1 spark plug and feeling the pressure being developed in the cylinder as the piston rises, or by removing the rocker cover and noting when the valves of No 4 cylinder are rocking, ie the inlet valve just opening and the exhaust valve just closing. On manual transmission models, the engine can be turned over quite easily by engaging top gear and moving the car forwards. This should only be done on level ground; and make sure that the car cannot run away! An alternative method, and the method that should be used on automatic transmission models, is to press the fan belt midway between the water pump pulley and dynamo or alternator pulley and then turn the fan blades. Fine positioning of the torque converter can be done by inserting a screwdriver through the access hole and turning the ring gear.



**Turning the engine will be easier if the spark plugs are removed first - see Chapter 1.**

**6** Continue turning the engine, in the correct direction of rotation, until No 1 piston is at TDC on the compression stroke. Verify this by checking that the timing marks are aligned. The timing marks on the flywheel (or torque converter), and the pointer on the housing, can be viewed through the inspection aperture using a small mirror. The 1/4 mark on the flywheel or torque converter indicates TDC and should be aligned with the pointer in the housing. On later models with a timing scale on the timing cover, the notch in the crankshaft pulley should be aligned with the 0 pointer on the timing cover scale.

**7** The distributor rotor arm should now be pointing towards the No 1 spark plug HT lead segment in the distributor cap indicating that the crankshaft is correctly positioned with number 1 cylinder at TDC on its compression stroke. Temporarily place the cap in position to verify this if necessary. If the rotor arm is pointing at the No 4 HT lead segment in the cap, rotate the crankshaft one full turn (360°) until the TDC timing marks are realigned and the rotor arm is pointing at the No 1 segment.

### 4 Valve clearances - adjustment



**1** The valve adjustments should be made with the engine cold. The importance of correct rocker arm/valve stem clearances cannot be overstressed as they vitally affect the performance of the engine. If the clearances are set too wide, the efficiency of the engine is reduced as the valves open later and close earlier than was intended. If, on the other hand the clearances are set too close there is danger that the stems will expand upon heating and not allow the valves to close properly, which will cause burning of the valve head and seat, and possible warping.

**2** To gain access to the rocker arms, remove the ignition shield (where fitted) from the front of the engine then undo the two rocker cover retaining bolts. Lift out the bolts along with the ignition shield brackets and lift the rocker cover and gasket away. Collect the rocker cover retaining bolt dished washers from the top of the two rubber seals.

**3** It is important that the clearance is set when the tappet of the valve being adjusted is on the heel of the cam, (ie opposite the peak). Turn the engine until valve No 8 (nearest the flywheel end of the engine) is fully open. With the engine in this position, valve No 1 will be fully closed and ready to be checked. On manual transmission models, the engine can be turned over quite easily by engaging top gear and moving the car forwards. This should only be done on level ground; and make sure that the car cannot run away! An alternative method, and the method that should be used on automatic transmission models, is to press the fan belt midway between the water pump pulley and dynamo or alternator pulley and then turn the fan blades.



**Turning the engine will be easier if the spark plugs are removed first - see Chapter 1.**

**4** A feeler blade of the correct thickness should now be inserted between the valve stem and rocker arm. When the clearance is correct the feeler blade should be a smooth stiff sliding fit between the valve stem and rocker arm. The correct valve clearances are given in the *Specifications* at the start of this Chapter.

**5** If the feeler blade is a tight or loose fit then the clearance must be adjusted. To do this, loosen the locknut of the adjustment stud and screw the adjuster stud in or out until the feeler blade can be felt to drag slightly when drawn from the gap (**see illustration**).

**6** Hold the adjuster firmly in this position and tighten the locknut. Recheck the gap on completion to ensure that it has not altered when locking the nut and stud.

**7** Check each valve clearance in turn in the following sequence (which also avoids turning



4.5 Adjusting the valve clearances

the crankshaft more than necessary). The valves are numbered from the timing chain end of the engine.

#### Valve fully open

Valve No 8  
Valve No 6  
Valve No 4  
Valve No 7  
Valve No 1  
Valve No 3  
Valve No 5  
Valve No 2

#### Check and adjust

Valve No 1  
Valve No 3  
Valve No 5  
Valve No 2  
Valve No 8  
Valve No 6  
Valve No 4  
Valve No 7

**8** When all the valves have been checked and adjusted, refit the rocker cover using a new gasket and secure with the retaining bolts. Where applicable, remember to fit the ignition shield brackets with the retaining bolts. Avoid over-tightening the rocker cover bolts.

**9** Refit the spark plugs, HT leads and ignition shield.

### 5 Timing chain, tensioner and sprockets - removal, inspection and refitting



#### Removal

**1** Disconnect the battery negative lead.

**2** Refer to Chapter 1 and remove the fan belt.

**3** Refer to Chapter 3 and remove the radiator.

**4** Undo the bolts securing the fan to the water pump spindle, and remove the fan.

**5** On later models, it may be necessary to remove the lower radiator mounting bracket to gain the necessary clearance to allow removal of the crankshaft pulley. To do this, undo the two nuts and bolts, accessed from underneath the wheel arch, securing the left-hand engine mounting to the subframe. Position a jack with interposed block of wood beneath the engine/transmission and carefully lift the jack until the engine/transmission is raised slightly. Undo the nuts and through-bolts securing the mounting bracket to the transmission, and remove the bracket assembly from the vehicle (**see illustration**).

**6** Bend back the locking tab of the crankshaft pulley locking washer under the crankshaft pulley retaining bolt, prising it back with a cold



5.5 Left-hand mounting bracket attachment bolts (arrowed) on later manual transmission models

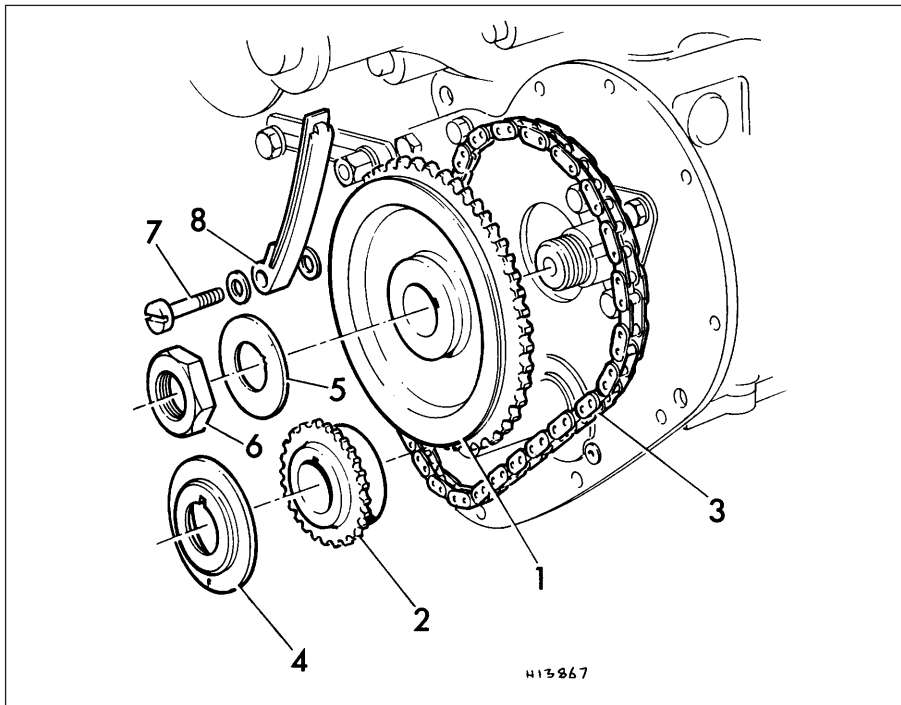

5.13 Timing sprocket and chain assembly - later type with tensioner arm

- |                       |               |                            |
|-----------------------|---------------|----------------------------|
| 1 Camshaft sprocket   | 4 Oil thrower | 7 Tensioner retaining bolt |
| 2 Crankshaft sprocket | 5 Lockwasher  | 8 Tensioner                |
| 3 Timing chain        | 6 Nut         |                            |

chisel or screwdriver through the radiator grille in the wing. Using a suitable socket or spanner remove the bolt and locking washer. This bolt is sometimes very difficult to shift, and hitting the free end of the spanner with a heavy hammer is often the only way to start it. Engage top gear and apply the handbrake hard to prevent the engine from turning. Alternatively, remove the starter motor (Chapter 5A) and lock the flywheel with a screwdriver or similar tool engaged with the ring gear teeth.

**7** Once the bolt has been slackened, set the engine at TDC for No 1 piston as described in Section 3.

**8** Placing two large screwdrivers behind the crankshaft pulley at 180° to each other, carefully lever the pulley off. It is preferable to use a proper pulley extractor if this is available, but large screwdrivers or tyre levers are quite suitable, providing care is taken not to damage the pulley flange.

**9** Remove the Woodruff key from the crankshaft nose with a pair of pliers and store it safely as it is a very small part and can easily be mislaid.

**10** Unscrew the bolts holding the timing cover to the block. **Note:** Four of the bolts are larger than the others and each bolt makes use of a large flat washer as well as a spring washer.

**11** Take off the timing cover and gasket. If fitted, detach the engine breather hose from the cover.

**12** With the timing cover removed, slide off the oil thrower. **Note:** The concave side faces forward.

**13** Bend back the locking tab on the washer under the camshaft retaining nut and unscrew the nut, noting how the locking washer locating tag fits in the camshaft sprocket keyway (see illustration).

**14** To remove the camshaft and crankshaft sprockets complete with chain, ease each sprocket forward a little at a time, levering behind each one in turn with two large screwdrivers at 180° to each other. If the sprockets are locked solid, it will be necessary to use a suitable puller. With both sprockets removed, extract the Woodruff keys from the crankshaft and camshaft with a pair of pliers and store them safely. Note that



5.19 Fitting a new tensioning ring to the camshaft

there may be a number of very thin packing washers behind the crankshaft sprocket; if so carefully remove them.

**15** On later models, unscrew the timing chain tensioner retaining bolt and remove the bolt and tensioner. Note that there is a washer on each side of the tensioner arm.

### Inspection

**16** Thoroughly clean all the components with paraffin or a suitable solvent and dry thoroughly. Pay particular attention to the timing cover and the mating face on the engine front plate, ensuring that all traces of old gasket are removed.

**17** Examine the teeth on both the crankshaft and camshaft sprockets for wear. Each tooth forms an inverted "V" with the sprocket periphery and, if worn, the side of each tooth under tension will be slightly concave in shape when compared with the other side of the tooth. If any sign of wear is present the sprockets must be renewed.

**18** Examine the links of the chain for side slackness and renew the chain if any slackness is noticeable when compared with a new chain. It is a sensible precaution to renew the chain at about 60 000 miles, and at a lesser mileage if the engine is dismantled for a major overhaul. The actual rollers on a very badly worn chain may be slightly grooved. Cooper S type engines use duplex chains.

**19** Also check the rubber tension rings in the camshaft sprocket, where fitted. It is quite likely that the rubber will have become hard due to heat and oil contamination and it is advisable to renew them as a matter of course. The rings are simply prised out with a screwdriver and new rings stretched over the sprocket flanges and into the grooves (see illustration). A spring-loaded rubber tensioning pad may be fitted to the timing cover on Cooper S type and later engines in place of the tensioning rings. If the rubber pad is grooved where it bears against the chain, it should also be renewed.

**20** It is advisable to renew the timing cover oil seal at this stage. Drive out the old seal and tap in the new one using the old seal to spread the load. Ensure that the open side of the seal faces inward, towards the chain.

### Refitting

**Note:** Before reassembly begins check that the original packing washers are in place on the crankshaft nose. If new sprockets are being fitted it may be necessary to fit additional washers (see paragraph 25). These washers ensure that the crankshaft sprocket lines up correctly with the camshaft sprocket.

**21** Refit the Woodruff keys in their respective slots in the crankshaft and camshaft, and ensure that they are fully seated. If their edges are burred they must be cleaned with a fine file.

**22** Lay the two sprockets on a clean surface so that the timing dots are adjacent to each other. Slip the timing chain over them and pull



5.22a Timing dots on sprockets aligned with chain fitted

the sprockets back into mesh with the chain so that the timing dots, although further apart are still adjacent to each other (see illustrations).

23 Check that the engine is still positioned at TDC for No 1 piston (Section 3). In this position the crankshaft Woodruff key should be at the 12 o'clock position and the camshaft Woodruff key should be at the 2 o'clock position.

24 Fit the timing chain and sprocket assembly onto the camshaft and crankshaft, keeping the timing marks adjacent. If the camshaft and crankshaft have been positioned accurately, it will be found that the keyways on the sprockets will match the position of the keys, although it may be necessary to rotate the camshaft a fraction to ensure accurate lining-up of the camshaft sprocket.

25 Press the sprockets into position on the crankshaft and camshaft as far as they will go.

**Note:** If new sprockets are being fitted they should be checked for alignment before being finally fitted to the engine. Place the sprockets in position without the timing chain and place the straight edge of a steel ruler from the side of the camshaft gear teeth to the crankshaft sprocket and measure the gap between the steel rule and the sprocket (see illustration). If a gap exists a suitable number of packing washers must be placed on the crankshaft nose to bring the crankshaft sprocket onto the same plane as the camshaft sprocket.

26 Fit the oil thrower to the crankshaft with the concave side forward.

27 Fit the locking washer to the camshaft sprocket with its locating tab in the sprocket keyway.

28 Screw on the camshaft sprocket retaining nut and tighten securely.

29 Bend up the locking tab of the locking washer to hold the camshaft retaining nut securely.

30 On engines with a separate timing chain tensioner, refit the tensioner and retaining bolt ensuring that there is a washer on each side of the tensioner arm.

31 Generously oil the chain and sprockets.

32 Apply a bead of RTV sealant to each side of the new gasket, on the lower half of the gasket only. Place the gasket on the timing cover then quickly position the timing cover on the engine.

33 Screw in the timing cover retaining bolts with the flat washer next to the cover flange and under the spring washer. Tighten the respective bolts to the specified torque.

34 Fit the crankshaft pulley to the nose of the crankshaft, ensuring that the keyway engages with the Woodruff key.

35 Fit the crankshaft retaining bolt locking washer and screw in the crankshaft pulley retaining bolt. Tighten to the specified torque while using the same method to prevent crankshaft rotation as was used for removal.

36 Where removed, refit the radiator lower mounting bracket and secure the bracket to the engine/transmission and subframe. Remove the jack under the engine.

37 Refit the fan to the water pump spindle and secure with the four bolts securely tightened.

38 Refit the radiator as described in Chapter 3 and the fan belt as described in Chapter 1.

39 Refit the components removed when setting the engine at TDC, then reconnect the battery.

## 6 Rocker shaft assembly - removal, inspection and refitting



### General information

1 The rocker shaft assembly is secured to the top of the cylinder head by the cylinder head inner studs and nuts. Although in theory it is possible to undo the head nuts and remove the rocker shaft assembly without removing the head, in practice, this is not recommended.

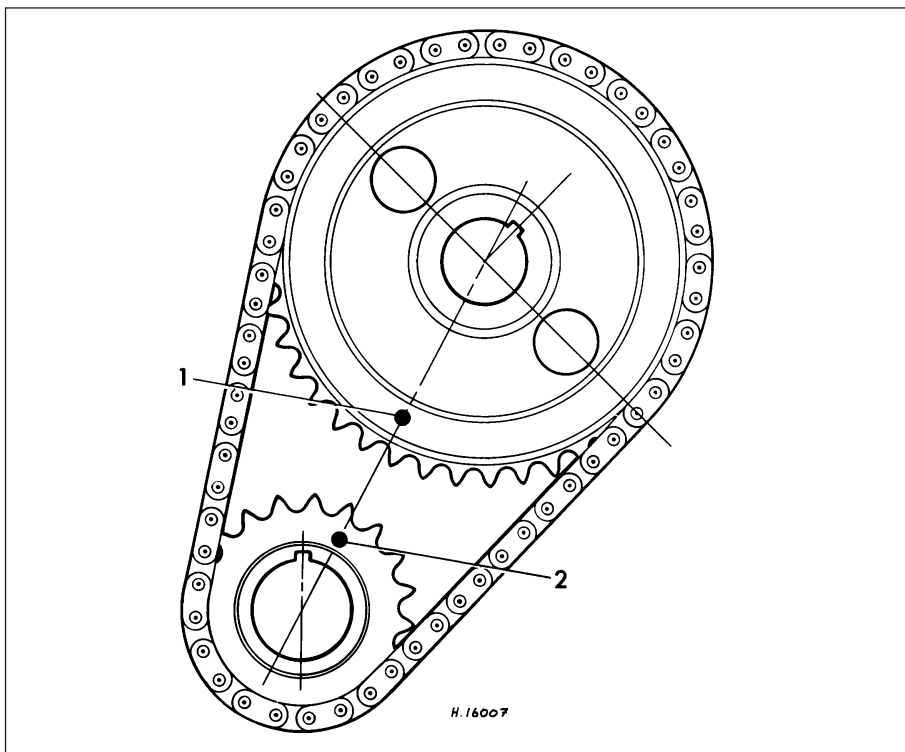

5.22b Timing mark locations relative to keyways

1 Timing dot on camshaft sprocket

2 Timing dot on crankshaft sprocket

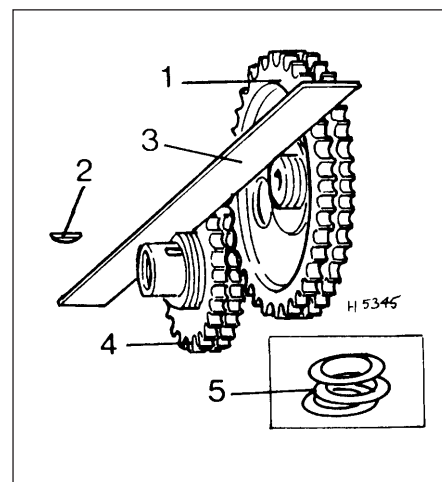

5.25 Timing sprocket alignment - double row type shown

1 Camshaft sprocket 4 Crankshaft

2 Woodruff key sprocket

3 Straight edge 5 Inset: shims

Note that with single row type, it is important to align the sides of the teeth and not the raised hub of the sprocket



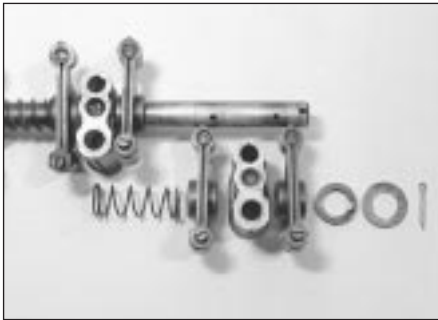

**6.3 Rocker shaft components dismantled for inspection**

Once the nuts have been removed, the head gasket will be disturbed, and the gasket will almost certainly leak or blow after refitting. For this reason, removal of the rocker shaft assembly cannot be done without removing the cylinder head and renewing the head gasket.

**Removal**

- 2 Remove the cylinder head as described in Section 7 or 8 as applicable.
- 3 To dismantle the rocker shaft assembly, release the rocker shaft locating screw, remove the split pins, flat washers, and spring washers from each end of the shaft and slide from the shaft the pedestals, rocker arms, and rocker spacing springs (**see illustration**). Keep all the components in order and make a note of each component's correct fitted position and orientation as it is removed, to ensure it is fitted correctly on reassembly.

**Inspection**

- 4 Check the rocker arms for wear of the rocker bushes, for wear at the rocker arm face which bears on the valve stem, and for wear of the adjusting ball-ended screws. Wear in the rocker arm bush can be checked by gripping the rocker arm tip and holding the rocker arm in place on the shaft, noting if there is any lateral rocker arm shake. If shake is present, and the arm is very loose on the shaft, remedial action must be taken. Pressed steel valve rockers cannot be renovated by renewal of the rocker arm bush. It is necessary to fit new rocker arms. Forged rocker arms which have worn bushes may be taken to a Rover dealer or engine reconditioning specialist to have the old bush drawn out and a new bush fitted. Forged rockers and pressed steel rockers are interchangeable in sets of eight, but, where one or two pressed steel rockers only require renewal, it is not advised to replace them with the forged type.
- 5 Check the tip of the rocker arm where it bears on the valve head for cracking or serious wear on the case hardening. If none is present re-use the rocker arm. Check the lower half of the ball on the end of the rocker arm adjusting screw. On high performance mini engines, wear on the ball and top of the

pushrod is easily noted by the unworn "pip" which fits in the small central oil hole on the ball. The larger this "pip" the more wear has taken place to both the ball and the pushrod. Check the pushrods for straightness by rolling them on the bench. Renew any that are bent.

**Refitting**

- 6 To reassemble the rocker shaft fit the split pin, flat washer and spring washer at the rear end of the shaft and then slide on the rocker arms, rocker shaft pedestals, and spacing springs in the same order in which they were removed.
- 7 With the front pedestal in position, screw in the rocker shaft locating screws and slip the locating plate into position. Finally, fit to the front of the shaft the spring washer, plain washer, and split pin, in that order.
- 8 Refit the cylinder head as described in Section 7 or 8.

**7 Cylinder head (carburettor engines) - removal and refitting**



**Note:** *If working on a pre-1990 engine fitted with emission control equipment, it will be necessary to first remove the diverter valve, air pump and associated hoses before proceeding with the removal sequence. Detailed removal procedures for these components will be found in Chapter 4C.*

**Removal**

- 1 Disconnect the battery negative lead. For improved working clearance, remove the bonnet as described in Chapter 11.
- 2 Drain the cooling system as described in Chapter 1.
- 3 Slacken the clips securing the radiator top hose and remove the hose.
- 4 On models fitted with an ignition shield over the front of the engine, release the three retaining lugs and lift off the shield.
- 5 Make a note of the electrical connections at the ignition coil and disconnect them. Now undo and remove the nut securing the coil bracket to the cylinder head and lift away the coil.
- 6 Undo and remove the nuts or bolts securing

the radiator upper support bracket to the thermostat housing and radiator. Remove the bracket.

- 7 Refer to Chapter 4A and remove the air cleaner assembly and carburettor(s).
- 8 Undo and remove the retaining nuts and bolts, and lift off the clamps securing the exhaust front pipe to the manifold. On Cooper S models, undo and remove the nuts and flat washers securing the inlet and exhaust manifolds to the cylinder head. Lift off the inlet manifold, ease the exhaust manifold back off the cylinder head studs and tie it securely in this position.
- 9 Slacken the water pump-to-cylinder head bypass hose retaining clips.
- 10 Slacken the securing clip and remove the heater hose from the heater valve on the cylinder head. Now disconnect the control cable from the valve.
- 11 Make a note of their positions and then remove the HT leads from the spark plugs.
- 12 Detach the temperature gauge electrical lead from the sender unit.
- 13 Undo the two rocker cover retaining bolts. Lift out the bolts along with the ignition shield brackets and lift the rocker cover and gasket away. Collect the rocker cover retaining bolt dished washers from the top of the two rubber seals.
- 14 Slacken the four rocker pedestal nuts and the nine main cylinder head nuts, half a turn at a time, in the reverse sequence to that shown (**see illustration 7.31**). On some 1275 cc engines an additional nut and bolt are located at the front and rear of the cylinder head, and these must be released first. When the tension is released from all the nuts, they may then be removed, one at a time, from their studs.
- 15 Recover the pedestal plate (where fitted) the lift off the rocker shaft assembly complete and place it to one side (**see illustrations**).
- 16 Lift out the pushrods, keeping them in order according to their respective valves (**see illustration**).

**HAYNES** **HiNT** *The easiest way to keep the pushrods in order is to push them through a sheet of thick paper or thin card, in the correct sequence, then number them 1 to 8.*



**7.15a Recover the pedestal plate (where fitted) . . .**



**7.15b . . . then lift off the rocker shaft assembly**



7.16 Remove the pushrods, keeping them in order

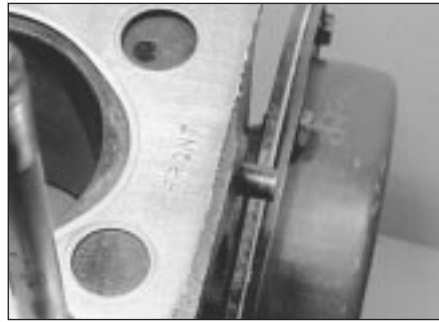

7.25a The cylinder head gasket is marked FRONT . . .



7.25b . . . and TOP

17 The cylinder head can now be removed by lifting upwards. If the head is jammed, try to rock it to break the seal. Under no circumstances try to prise it apart from the block with a screwdriver or cold chisel, as damage may be done to the faces of the head or block. If other methods fail to work, strike the head sharply with a plastic or wooden headed hammer, or with a metal hammer with an interposed piece of wood to cushion the blows. Under no circumstances must you hit the head directly with a metal hammer, as this may cause the iron casting to fracture. Several sharp taps with the hammer, at the same time pulling upwards, should free the head. Lift the head off squarely and place it on one side.

18 If the cylinder head is to be dismantled for overhaul, refer to Part B of this Chapter. Refer to Section 6 if the rocker shaft assembly is to be dismantled.

### Preparation for refitting

19 The mating faces of the cylinder head and cylinder block must be perfectly clean before refitting the head. Use a metal or hard plastic scraper to remove all traces of gasket and carbon; also clean the piston crowns. Take particular care during the cleaning operations, as the mating faces and piston crowns can be

easily scored. Also, make sure that the carbon is not allowed to enter the oil and water passages - this is particularly important for the lubrication system, as carbon could block the oil supply to the engine's components. Using adhesive tape and paper, seal the water and oil holes in the cylinder block. To prevent carbon entering the gap between the pistons and bores, smear a little grease in the gap. After cleaning each piston, use a small brush to remove all traces of grease and carbon from the gap, then wipe away the remainder with a clean rag. Clean all the pistons in the same way.

20 Check the mating surfaces of the cylinder block and the cylinder head for nicks, deep scratches and other damage. If slight, they may be removed carefully with a file, but if excessive, machining may be the only alternative to renewal.

21 If warpage of the cylinder head gasket surface is suspected, use a straight-edge to check it for distortion. Refer to Part B of this Chapter if necessary.

22 Check the condition of the cylinder head studs and nuts, and particularly their threads. Wash the nuts in a suitable solvent and wipe clean the studs. Check each for any sign of visible wear or damage, renewing any if necessary.

### Refitting

23 After checking that both the cylinder block and cylinder head mating faces are perfectly clean, generously lubricate each cylinder with engine oil.

24 Always use a new cylinder head gasket as the old gasket will be compressed and not capable of giving a good seal. It is also easier at this stage to refit the small bypass hose from the water pump to the cylinder head.

25 The cylinder head gasket is marked "FRONT" and "TOP" and should be fitted in position according to the markings (see illustrations).

26 With the gasket in position carefully lower the cylinder head onto the cylinder block. Make sure that the bypass hose engages with the pipe stub on the cylinder head as the head is lowered into place.

27 Fit the cylinder head nuts and washers finger tight to the five cylinder head holding-down studs, which remain outside the rocker cover.

28 Fit the pushrods in the same order in which they were removed. Ensure that they locate properly in the stems of the tappets, and lubricate the pushrod ends before fitting.

29 The rocker shaft assembly can now be lowered over its eight locating studs. Take care that the rocker arms are the right way round. Lubricate the ball ends of the tappet adjusting screws and insert them in the pushrod cups. **Note:** Failure to place the ball ends in the cups can result in them seating on the edge of a pushrod or outside it when the head and rocker assembly is pulled down tight.

30 Fit the four rocker pedestal nuts and washers, and then the four cylinder head stud nuts and washers, which also serve to hold down the rocker pedestals. Pull the nuts down evenly, but without tightening them right up.

31 When all is in position, the nine cylinder head nuts and the four rocker pedestal nuts can be tightened down in the order shown (see illustration). Turn the nuts a quarter of a turn at a time and tighten to the specified torque

**Note:** On 1275 cc engines having an additional nut and bolt, these should be tightened last.

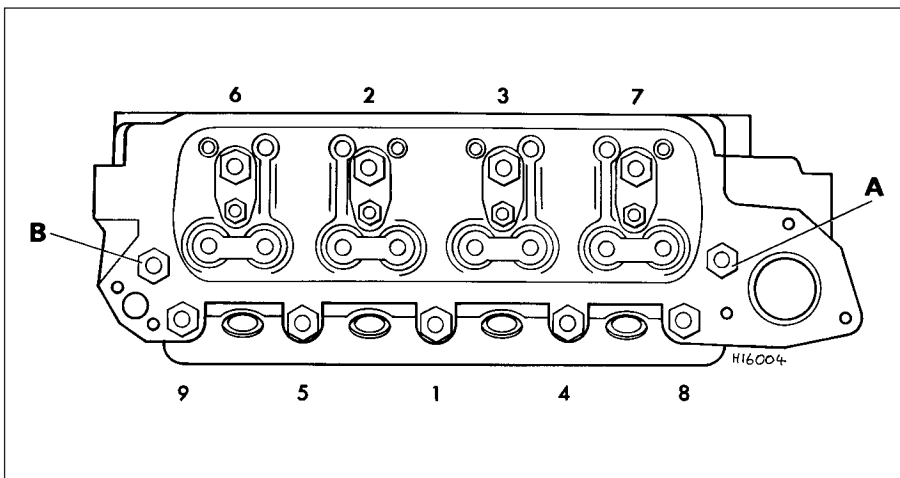

7.31 Cylinder head nut tightening sequence

A and B indicate additional bolt and nut on some 1275 cc engines. Reverse this order for slackening



**8.19a** Disconnect the two vacuum/breather hoses from the left-hand end of the cylinder head . . .



**8.19b** . . . and the single hose from the right-hand end



**8.20** Remove the nut and release the ignition coil bracket

- 32** Reconnect the wire to the temperature gauge sender unit.
- 33** Refit the heater hose to the heater valve then tighten the heater hose and the bypass hose retaining clips.
- 34** Refer to Chapter 4C and reconnect the exhaust front pipe and, on Cooper S models, the inlet and exhaust manifolds.
- 35** Refit the radiator upper support bracket.
- 36** Refit the ignition coil and bracket and reconnect the wiring.
- 37** Refit and secure the radiator top hose.
- 38** Refer to Chapter 4A and refit the carburettor(s).
- 39** Refer to Section 4 and adjust the valve clearances then refit the rocker cover, HT leads and associated components.
- 40** Reconnect the battery then refill the cooling system as described in Chapter 1. If removed, refit the bonnet, referring to Chapter 11 if necessary.

- the exhaust manifold), releasing it from any relevant cable-ties, and disconnect its wiring connector from the main harness.
- 8** Lower the car to the ground.
- 9** Undo the bolt and remove the retaining clip securing the injector housing fuel pipes to the bulkhead.
- 10** Bearing in mind the information contained in Chapter 4B, Section 6 on depressurising the fuel system, using an open-ended spanner to retain each adapter, slacken the union nuts and disconnect the feed and return pipes from the throttle body assembly. Plug each pipe and adapter, to minimise the loss of fuel and prevent the entry of dirt into the system.
- 11** Release the retaining clips and disconnect the wiring connectors from the injector housing, the throttle potentiometer and the stepper motor. Free the wiring from any relevant retaining clips, and position it clear of the throttle body assembly.
- 12** Slacken the accelerator cable locknuts, and free the outer cable from its mounting bracket. Release the inner cable from the throttle cam, and position the cable clear of the throttle body.
- 13** On automatic transmission models, disconnect the governor control rod from the throttle body linkage.
- 14** Disconnect the two vacuum hoses from the rear of the inlet manifold, noting their correct fitted positions; note that the hoses are colour-coded for identification purposes.
- 15** Undo the union bolt securing the brake servo vacuum hose to the inlet manifold, and recover the hose union sealing washers.
- 16** Slacken the retaining clips and disconnect the coolant hoses from the left-hand side of the inlet manifold.
- 17** Slacken the clips securing the radiator top hose to the thermostat housing and radiator, and remove the hose.
- 18** Undo the radiator upper mounting bracket retaining bolts, and remove the bracket from the side of the cylinder head and radiator.
- 19** Release the retaining clip(s), and disconnect the two vacuum/breather hoses from the left-hand end of the cylinder head, and the single hose from the right-hand end of the head (**see illustrations**).

- 20** Undo the nut securing the ignition coil to the front of the cylinder head, then release the coil from its mounting stud and position it clear of the cylinder head (**see illustration**).
- 21** Make a note of the correct fitted positions of the HT leads, and disconnect them from the spark plugs.
- 22** Remove the cylinder head assembly as described in paragraphs 13 to 18 of Section 7, noting that it will be necessary to disconnect the wiring connectors from the PTC heater and coolant temperature sensor (situated on the underside of the inlet manifold) as they become accessible.

**Preparation for refitting**

**23** Refer to Section 7, paragraphs 19 to 22.

**Refitting**

- 24** Refit the cylinder head as described in Section 7, not forgetting to reconnect the PTC heater and coolant temperature sensor wiring connectors as the head assembly is lowered into position on the cylinder block.
- 25** The remainder of the refitting process is a direct reversal of the removal procedure, noting the following points:
  - a) Ensure that all pipes/hoses are correctly reconnected, and (where necessary) are securely held in position by their retaining clips.
  - c) Tighten all nuts and bolts to the specified torque setting (where given).
  - d) Position a sealing washer on either side of the brake servo vacuum hose union, and tighten the union bolt securely.
  - e) Refill the cooling system as described in Chapter 1
  - f) On completion, reconnect the battery, and adjust the accelerator cable as described in Chapter 4B.

**8 Cylinder head (fuel injection engines) - removal and refitting**



**Note:** Observe the precautions in Section 1 of Chapter 4B before working on any component in the fuel system.

**Removal**

- 1** Disconnect the battery negative lead. For improved working clearance, remove the bonnet as described in Chapter 11.
- 2** Drain the cooling system as described in Chapter 1.
- 3** Release the fasteners and remove the ignition cover from the front of the engine.
- 4** Refer to Chapter 4B and remove the air cleaner assembly.
- 5** Chock the rear wheels then jack up the front of the car and support it on axle stands (see "Jacking and vehicle support").
- 6** Working from underneath the car, slacken and remove the single bolt securing the exhaust front pipe to its mounting bracket on the transmission. Undo the three nuts securing the front pipe to the manifold, then disconnect it and recover the gasket.
- 7** Trace the wiring back from the exhaust system lambda sensor (which is screwed into

**9 Crankshaft oil seals - renewal**



**Front (timing cover) oil seal**

- 1** Remove the timing cover as described in Section 5, paragraphs 1 to 6 and 8 to 11.
- 2** Thoroughly clean the timing cover with



paraffin or a suitable solvent and dry thoroughly. Pay particular attention to the mating faces of the cover and the engine front plate, ensuring that all traces of old gasket are removed.

**3** Drive out the old seal and tap in the new one using the old seal to spread the load. Ensure that the open side of the seal faces inward, towards the timing chain (**see illustration**).

**4** Refit the timing cover as described in Section 5, paragraphs 32 to 39.

### Rear (primary gear) oil seal - manual transmission models

**Note:** The majority of clutch faults experienced on Mini power units are caused by oil contamination of the clutch friction linings due to the failure of the primary gear oil seal. It is therefore recommended that the seal is renewed whenever problems of this nature are encountered. Note that Rover special tools 18G1068B and 18G1043 will be required for this operation.

**5** Remove the flywheel and clutch assembly as described in Chapter 6.

**6** The primary gear complete with oil seal can now be withdrawn from the crankshaft and flywheel housing as described below.

**7** Lift off the C-shaped thrustwasher and backing ring that retain the primary gear in position.

**8** Now screw in the threaded centre bolt of special tool 18G1068B until the base of the tool abuts the oil seal. Pull the primary gear outwards as far as it will go and slide the two collets of 18G1068B between the groove at the rear of the primary gear splines and the base of the tool body.

**9** Now slowly unscrew the threaded centre bolt of the tool while holding the tool body. This will cause the primary gear to be withdrawn from the flywheel housing, bringing the oil seal with it.

**10** When the primary gear and oil seal are clear of the housing, lift them off the end of the crankshaft, remove the tool and slide the oil seal off the primary gear.

**11** To fit a new oil seal first slide the primary gear onto the crankshaft and secure with the C-shaped washer and backing ring.

**12** To avoid damage to the oil seal as it is fitted, place the protective sleeve, special tool 18G1043, over the primary gear, or if this tool is not available cover the primary gear splines and the stepped shoulder with masking tape.

**13** Lubricate the lip of the oil seal, and very carefully slide it over the primary gear and into position against the flywheel housing. The open part of the seal must be facing towards the engine.

**14** Screw on the threaded centre bolt of special tool 18G1068B and, when the body of the tool contacts the seal, fully tighten the centre bolt, thus forcing the seal squarely into the housing. Remove the tool when the face of the seal is flush with the housing.

**15** The flywheel and clutch assembly can now be refitted as described in Chapter 6.



**9.3** Timing cover oil seal must be fitted with the open side towards the chain

### Rear (torque converter output gear) oil seal - automatic transmission models

**Note:** Rover special tools 18G1068B and 18G1098 should ideally be obtained for this operation.

**16** Remove the torque converter as described in Section 11.

**17** Note the fitted depth of the oil seal in the converter housing so that the new seal may be fitted in the same position.

**18** Using a hooked instrument, or alternatively Rover special tool 18G1087, extract the oil seal from the converter housing.

**19** To protect the lips of the new seal as it is fitted, wrap adhesive tape around the converter output gear splines or preferably use Rover special tool 18G1098.

**20** Using a suitable length of tubing or preferably Rover special tool 18G1068B, install the oil seal into the housing to the same position as noted during removal. Note that if the seal is not positioned correctly it may cover an important oil drain hole in the housing.

**21** The torque converter can now be refitted as described in Section 11.

### 10 Flywheel (manual transmission models) - removal and refitting

The flywheel on all manual transmission models is removed complete with the clutch assembly, the components then being separated after removal. Full details of clutch and flywheel removal and refitting are contained in Chapter 6.

### 11 Torque converter (automatic transmission models) - removal and refitting

#### Removal

**Note:** Rover special tool special tool 18G1086 will be required to release the torque converter from the crankshaft.

**1** Chock the rear wheels then jack up the front of the car and support it on axle stands (see "Jacking and vehicle support").

**2** Disconnect the battery negative lead. If greater working clearance is required, remove the bonnet as described in Chapter 11.

**3** Remove the front grille as described in Chapter 11.

**4** Detach the heater air duct from the air inlet under the right-hand front wing. Remove the air inlet from the inner wing panel.

**5** Remove the starter motor as described in Chapter 5A.

**6** On fuel injection models carry out the following:

a) Remove the air cleaner assembly, the engine management ECU and the crankshaft sensor as described in Chapter 4B.

b) Disconnect the oil separator breather hose from the right-hand end of the cylinder head, then undo the two bolts securing the separator to the torque converter housing. Remove the separator and hose assembly from the engine, along with its gasket.

c) Slacken and remove the screw, situated just to the right of the brake servo unit, securing the earth leads to the bulkhead.

d) Undo the bolts securing the wiring harness retaining clip and starter motor lead brackets to the converter housing, then position the wiring clear of the engine.

**7** On early models, undo and remove the screws securing the starter solenoid to the inner wing panel. Lift off the solenoid and position it out of the way.

**8** If the ignition coil is mounted on the flywheel housing, or on a bracket secured to one of the cylinder head studs, remove the coil and mounting bracket and position it well clear.

**9** On later Mini 850 and 1000 models, remove the horn and place it to one side.

**10** Undo and remove the two bolts securing the engine tie-bar and bracket to the side of the cylinder block. Note that on later models one of the bolts also retains the engine earth strap.

**11** Undo and remove the nuts and/or bolts securing the radiator upper support bracket to the radiator and thermostat housing. Withdraw the bracket. **Note:** It is not necessary to remove the support bracket if a large clearance exists between the radiator and left-hand inner wing panel, as is the case on later Mini 850 and 1000 models.

**12** Place a jack beneath the torque converter housing end of the transmission casing and just take the weight of the power unit. Use a block of wood interposed between the casing and the jack to spread the load.

**13** From beneath the car undo and remove the two nuts and bolts securing the right-hand engine mounting to the subframe side members. The best way to do this is to engage the help of an assistant to hold the bolts from above while the nuts are undone from below. The bolt heads are tucked away beneath the converter housing and can only be reached with a small open-ended spanner.

**14** Having released the mounting, jack up the power unit sufficiently to enable the nine bolts securing the converter housing cover to be removed. Note that on early models one of the front bolts also retains the engine earth strap. On all models the rear bolts are quite inaccessible, requiring a good deal of patience and a short spanner.

**15** When all the bolts are undone, lift off the converter housing cover.

**16** Knock back the locktabs, and undo and remove three equally spaced bolts from the centre of the converter. Leave the other three bolts in position.

**17** Knock back the lockwasher securing the large converter centre retaining bolt. Using a large socket and bar, undo and remove the torque converter centre bolt and withdraw the driving collar. Use a screwdriver inserted through the hole in the top of the converter housing and engaged with the ring gear teeth to prevent the torque converter from turning.

**18** Rotate the crankshaft until the timing marks on the converter periphery are at approximately the 3 o'clock position.

**19** The torque converter is a taper fit on the end of the crankshaft and it will be necessary to obtain Rover special tool 18G1086 to remove it. The tool is bolted to the torque converter through the holes of the three previously removed converter retaining bolts. With the adapter in position on the end of the crankshaft, tighten the tool centre bolt until the torque converter breaks free of the taper, and then lift it off the crankshaft.

### Refitting

**20** Set the engine with No 1 piston at TDC on compression as described in Section 3.

**21** Before fitting the torque converter, it will be first necessary to refit the three central bolts removed to allow the special converter removal tool to be used during dismantling. Then remove each pair of bolts in turn from the converter centre and fit new locking plates. Tighten the six bolts to the specified torque wrench setting and bend over the lock tabs. *On no account remove all six bolts at any one time.*

**22** Slide the torque converter onto the end of the crankshaft, with the timing marks uppermost. Refit the driving collar, a new lockwasher and the retaining bolt. Tighten the retaining bolt to the specified torque then knock back the lockwasher.

**23** The remainder of refitting is the reverse sequence to removal.

## 12 Engine/transmission mountings - renewal



### General information

**1** The engine/transmission is supported on two rubber mountings which are in turn bolted to the sides of the front subframe. One mounting is located under the radiator (left-

hand mounting), and the other at the base of the flywheel or torque converter housing cover, to which it is attached (right-hand mounting). Fore-and-aft movement of the power unit is controlled by a tie-bar, one end of which is attached to the engine, and the other to a bracket on the bulkhead. Rubber bushes are used at each end to absorb vibration. On later models an additional lower tie-bar is used, one end of which is bolted to the subframe and the other to a bracket on the transmission. A point worth noting is that the engine tie-bar rubber bushes are prone to wear and this is usually noticed as severe judder as the clutch is engaged on manual transmission models, or excessive movement of the complete power unit when accelerating and decelerating.

### Right-hand mounting renewal

**2** Chock the rear wheels then jack up the front of the car and support it on axle stands (see "Jacking and vehicle support").

**3** Disconnect the battery negative lead. If greater working clearance is required, remove the bonnet as described in Chapter 11.

**4** Remove the front grille, referring to Chapter 11 if necessary.

**5** Detach the heater air duct from the air inlet under the right-hand front wing. Remove the air inlet from the inner wing panel.

**6** Remove the starter motor as described in Chapter 5A.

**7** On fuel injection models carry out the following:

- Remove the air cleaner assembly, the engine management ECU and the crankshaft sensor as described in Chapter 4B.
- Disconnect the oil separator breather hose from the right-hand end of the cylinder head, then undo the two bolts securing the separator to the flywheel/torque converter housing. Remove the separator and hose assembly from the engine, along with its gasket.
- Slacken and remove the screw, situated just to the right of the brake servo unit, securing the earth leads to the bulkhead.
- Undo the bolts securing the wiring harness retaining clip and starter motor lead brackets to the flywheel/converter housing, then position the wiring clear of the engine.

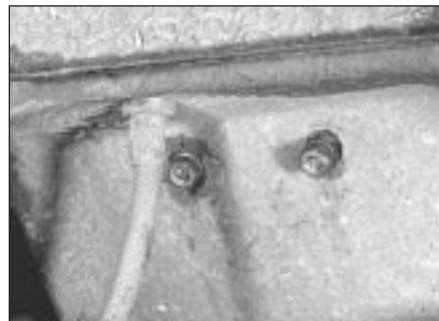

**12.15** Right-hand engine mounting-to-subframe retaining nuts

**8** On early models, undo and remove the screws securing the starter solenoid to the inner wing panel. Lift off the solenoid and position it out of the way.

**9** If the ignition coil is mounted on the flywheel/converter housing, or on a bracket secured to one of the cylinder head studs, remove the coil and mounting bracket and position it well clear.

**10** On manual transmission models, detach the clutch slave cylinder mounting plate from the flywheel housing, taking care to retain the spacer. Withdraw the cylinder from the pushrod and place the cylinder and mounting plate to one side.

**11** On later Mini 850 and 1000 models, remove the horn and place it to one side.

**12** Undo and remove the two bolts securing the engine tie-bar and bracket to the side of the cylinder block. Note that on later models one of the bolts also retains the engine earth strap.

**13** Undo and remove the nuts and/or bolts securing the radiator upper support bracket to the radiator and thermostat housing. Withdraw the bracket. **Note:** *It is not necessary to remove the support bracket if a large clearance exists between the radiator and left-hand inner wing panel, as is the case on later Mini 850 and 1000 models.*

**14** Place a jack beneath the flywheel/torque converter housing end of the transmission casing and just take the weight of the power unit. Use a block of wood interposed between the casing and the jack to spread the load.

**15** From beneath the car undo and remove the two nuts and bolts securing the right-hand engine mounting to the subframe side members (see illustration). The best way to do this is to engage the help of an assistant to hold the bolts from above while the nuts are undone from below. The bolt heads are tucked away and can only be reached with a small open-ended spanner.

**16** Having released the mounting, jack up the power unit sufficiently to enable the nine bolts securing the flywheel/converter housing cover to be removed. Note that on early models one of the front bolts also retains the engine earth strap. On all models the rear bolts are quite inaccessible, requiring a good deal of patience and a short spanner.

**17** When all the bolts are undone, lift off the flywheel/converter housing cover.

**18** With the cover removed, undo the bolts securing the engine mounting and lift off the mounting.

**19** Refitting is the reverse sequence to removal.

### Left-hand mounting renewal

**20** Remove the radiator as described in Chapter 3.

**21** Position a jack beneath the left-hand side of the transmission casing, and, using a block of wood to spread the load, just take the weight of the power unit.



**12.25 Removing the engine upper tie-bar from the cylinder block**

**22** Undo and remove the two nuts, bolt and spring washers securing the mounting to the subframe.

**23** Raise the jack slightly and remove the bolts securing the mounting to the bracket on the transmission casing. The engine mounting can now be withdrawn.

**24** Refitting is the reverse sequence to removal.

**Upper tie-bar and bushes renewal**

**25** Undo and remove the two bolts securing the tie-bar and mounting bracket to the right-hand side of the engine (see illustration). Move the tie-bar sideways and recover any spacing washers that may be fitted.

**26** If the tie-bar is secured to its mounting bracket on the bulkhead by a through-bolt and locknut, remove the locknut and bolt and lift away the tie-bar.

**27** If the tie-bar is secured by a stud with nuts and spring washers at each end, undo



**12.30 Lower engine tie-bar attachments**

and remove the nuts and spring washers, then slacken the four nuts securing the clutch and brake master cylinder to the bulkhead. When sufficient clearance exists, lift up the tie-bar upper mounting bracket over the tie-bar stud, and withdraw the tie-bar.

**28** With the tie-bar removed, slide out the rubber bushes and spacers and, if there is any sign of swelling or deterioration of the rubber whatsoever, renew the bushes.

**29** Refitting is the reverse sequence to removal.

**Lower tie-bar and bushes renewal**

**30** The lower tie-bar fitted to later models may be mounted in one of two positions; either bolted to a bracket on the left-hand side of the transmission at one end and to the rear of the subframe at the other, or bolted to a bracket on the right-hand side of the transmission at one end and to the front of the

subframe at the other. The renewal procedure is the same for both types (see illustration).

**31** Chock the rear wheels then jack up the front of the car and support it on axle stands (see "Jacking and vehicle support").

**32** Undo and remove the bolts securing the tie-bar to the transmission bracket and subframe, and withdraw the tie-bar.

**33** To remove the bushes it will be necessary to draw them out using a tube of suitable diameter, a long bolt and nut, and packing washers. The new bushes are refitted in the same way but lubricate them with liquid detergent before fitting.

**34** Refitting is the reverse sequence to removal.

**13 Distributor driveshaft - removal and refitting**



**Removal**

**1** Set the engine with No 1 cylinder at TDC on compression as described in Section 3.

**2** Remove the distributor as described in Chapter 5B.

**3** Where a distributor base housing is fitted to the cylinder block, unscrew the single retaining bolt and lockwasher and remove the housing.

**4** Look down into the distributor aperture and observe the position of the slot in the distributor driveshaft. With No 1 piston at TDC, the slot should be positioned as shown according to engine type (carburettor engines or fuel injection engines) (see illustrations).

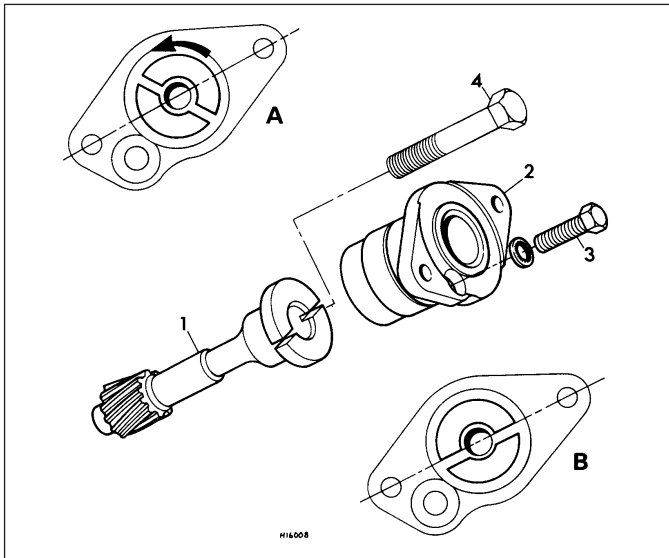

**13.4a Distributor driveshaft components and fitting details - carburettor engines**

*Inset A shows the position of the slot ready for fitting  
Inset B shows the shaft correctly installed*

- 1 Driveshaft
- 2 Housing
- 3 Retaining screw
- 4 1/16 in UNF bolt (for removal and refitting of driveshaft)

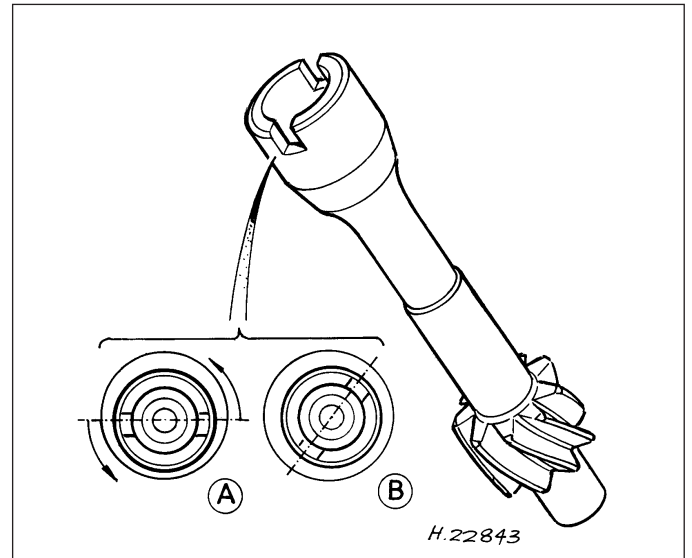

**13.4b Distributor driveshaft fitting details - fuel-injection models**

*A Drive slot position prior to engagement with skew gear  
B Correct drive slot position with shaft correctly installed*



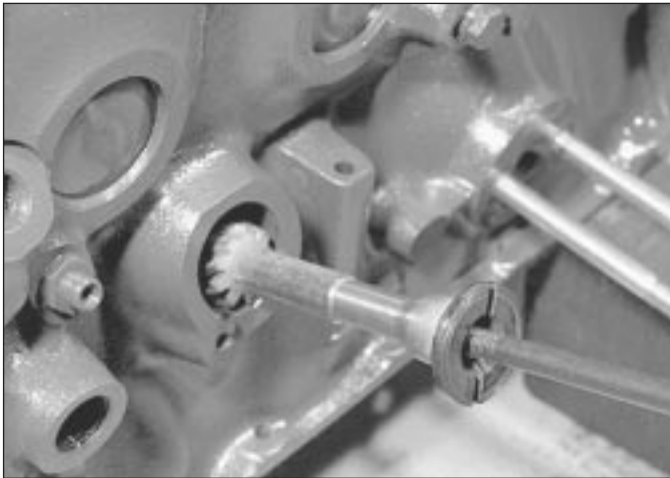

13.5 Using a 5/16 in UNF bolt to remove the distributor driveshaft

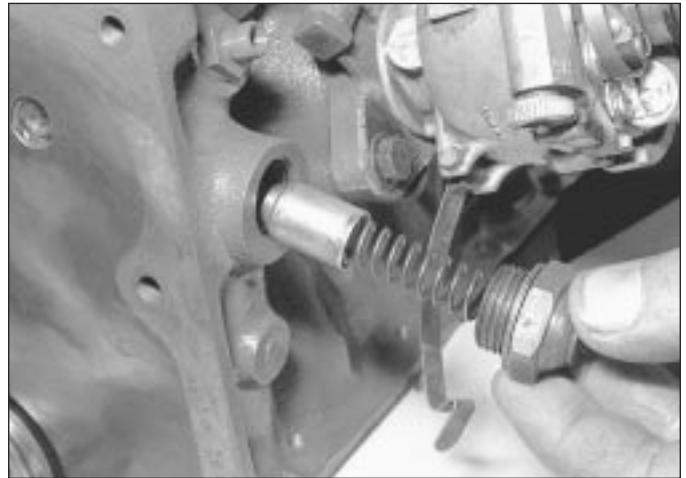

14.2 Removing the oil pressure relief valve

There is a degree of conflicting information from the manufacturer as to the correct position of this slot on later engines. As a general rule, when refitting the driveshaft, set the slot in the same position it was in prior to removal. If there is any doubt about the original position, set it as shown in the illustrations when refitting.

5 Screw into the end of the distributor driveshaft a 5/16 in UNF bolt. A tappet cover bolt (where fitted) is ideal for this purpose. The driveshaft can then be lifted out, the shaft being turned slightly in the process to free the shaft skew gear from the camshaft skew gear (see illustration).

### Refitting

6 With the engine still positioned with No1 piston at TDC, hold the driveshaft so that its slot is in the correct position for refitting as shown in the accompanying illustrations, ie so that its larger segment is uppermost (offset slot towards the bottom). Engage the driveshaft gear with the camshaft skew gear, and push the drive fully into position. As the gear engages, the driveshaft will rotate anti-clockwise to the final, correct fitted position. If necessary, withdraw the driveshaft again and adjust its position as necessary until this is so.  
7 Remove the bolt from the driveshaft.

8 Where applicable, refit the distributor base housing using a new O-ring and lock it in position with the single bolt and lockwasher.

9 The distributor can now be refitted as described in Chapter 5B.

## 14 Oil pressure relief valve - removal, inspection and refitting

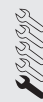

### Removal

1 To prevent excessive oil pressure - for example when the engine is cold - an oil pressure relief valve is built into the right-hand side of the engine just below the oil delivery pipe union.

2 The relief valve is identified externally by a large domed hexagon nut. To remove the unit unscrew the nut and remove it, complete with the two fibre or copper sealing washers. The relief spring and the relief spring cup can then be easily extracted (see illustration).

### Inspection

3 In position, the metal cup fits over the opposite end of the relief valve spring resting in the dome of the hexagon nut, and bears against a machining in the block. When the oil

pressure exceeds the specified pressure the cup is forced off its seat and the oil returns, via a drilling, directly to the sump.

4 Check the tension of the spring by measuring its free length. If it is shorter than the length shown in the *Specifications* it should be renewed. Check the condition of the cup checking carefully for wear ridges which would prevent the cup seating effectively. Renew the cup if its condition is suspect.

### Refitting

5 Refitting is the reverse sequence to removal.

## 15 Oil filter housing and delivery pipe - removal and refitting

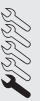

### Removal

1 Drain the engine/transmission oil and remove the oil filter as described in Chapter 1.

2 On manual transmission models, Unscrew the banjo union bolt securing the delivery pipe to the cylinder block. Note that on later 1275 cc engines a tube nut and olive type fitting is used instead of the banjo union. At the other end of the pipe unscrew the nut securing the pipe to the oil filter housing (see illustrations). Lift away the pipe and collect the two copper washers at the banjo union, or the rubber seals at the tube nut connections, according to type. be prepared for oil spillage.

3 On manual transmission models, unscrew the two nuts and slide the oil filter housing off the cylinder block studs. Recover the gasket.

4 On automatic transmission models, undo the two bolts and remove the filter housing from the top of the transmission casing flange. Recover the gasket.

5 Thoroughly clean the components and remove all traces of gasket from the mating surfaces.



15.2a Oil feed pipe banjo union at the engine . . .



15.2b . . . and pipe nut attachment at the filter housing

**6** If oil leakage from the pipe unions on later 1275 cc (12A) engines has been experienced, a modified pipe and tube nut assembly is available. Consult a Rover dealer for further information on this modification.

### **Refitting**

**7** Refitting is the reverse sequence to removal, bearing in mind the following points:

- a) *Use a new filter housing gasket and new copper washers at the banjo union.*
- b) *When refitting the delivery pipe with banjo union fitting, engage the threads of the union nut at the filter housing first, then fit the banjo union with a copper washer on each side of the union head. Tighten the fittings securely.*

## **16 Oil cooler - removal and refitting**



### **Removal**

- 1** Disconnect the battery negative lead.
- 2** Remove the front grille as described in Chapter 11.
- 3** Place a suitable container below the oil cooler. On Cooper S models, unscrew the two hose unions from the top of the oil cooler and move the hoses clear. On 1990-on 1275 cc engines, unscrew the banjo union bolt on the top of the oil cooler and recover the two

sealing washers. On all models, cover the disconnected unions with tape to prevent entry of dust and dirt.

- 4** Unscrew the mounting bolts and withdraw the oil cooler. On 1990-on 1275 cc engines, unscrew the lower banjo union bolt when sufficient clearance exists and recover the two sealing washers.

### **Refitting**

- 5** Refitting is a reversal of removal, but top-up the engine oil level as necessary (see "Weekly Checks").

# Chapter 2 Part B:

## Engine removal and overhaul procedures

### Contents

Camshaft and tappets - removal, inspection and refitting . . . . .	9	Engine/transmission removal - preparation and precautions . . . . .	2
Crankshaft - refitting and running clearance check . . . . .	17	Engine/transmission (with front subframe) - removal and refitting . .	4
Crankshaft - removal and inspection . . . . .	12	General information . . . . .	1
Cylinder block/crankcase - cleaning and inspection . . . . .	13	Main and big-end bearings - inspection and selection . . . . .	14
Cylinder head - dismantling, cleaning, inspection and reassembly .	8	Oil pump - removal, inspection and refitting . . . . .	10
Engine - initial start-up after overhaul and reassembly . . . . .	19	Piston/connecting rod assemblies - refitting and big-end bearing clearance check . . . . .	18
Engine and automatic transmission - separation and reconnection .	6	Piston/connecting rod assemblies - removal, inspection, separation and reconnection . . . . .	11
Engine and manual transmission - separation and reconnection . . .	5	Piston rings - refitting . . . . .	16
Engine overhaul - preliminary information . . . . .	7		
Engine overhaul - reassembly sequence . . . . .	15		
Engine/transmission - removal and refitting . . . . .	3		

### Degrees of difficulty

<b>Easy</b> , suitable for novice with little experience 	<b>Fairly easy</b> , suitable for beginner with some experience 	<b>Fairly difficult</b> , suitable for competent DIY mechanic 	<b>Difficult</b> , suitable for experienced DIY mechanic 	<b>Very difficult</b> , suitable for expert DIY or professional 
---	--	--	---	--

### Specifications

#### Engine general

Engine codes:

85H . . . . .	848 cc engines
99H . . . . .	998 cc engines
10H . . . . .	1098 cc engines
12H . . . . .	1275 cc engines
12A . . . . .	1275 cc engines

#### Valves

Valve head diameter:

Inlet:	
85H . . . . .	27.76 to 27.89 mm
10H . . . . .	29.23 to 29.36 mm
12H:	
1275 GT . . . . .	33.20 to 33.32 mm
Cooper S Mk III . . . . .	35.58 to 35.71 mm
12A . . . . .	35.58 to 35.71 mm
Exhaust:	
85H, 99H and 10H . . . . .	25.40 to 25.53 mm
12H:	
1275 GT . . . . .	29.24 to 29.37 mm
Cooper S Mk III . . . . .	30.83 to 30.96 mm
12A . . . . .	29.25 to 29.38 mm

Valve stem diameter:

Inlet . . . . .	7.094 to 7.107 mm
Exhaust . . . . .	7.082 to 7.094 mm

Valve stem-to-guide clearance:

Inlet:	
85H, 99H and 10H . . . . .	0.038 to 0.064 mm
12H and 12A . . . . .	0.040 to 0.080 mm
Exhaust:	
85H, 99H and 10H . . . . .	0.051 to 0.076 mm
12H and 12A . . . . .	0.040 to 0.080 mm

Valve seat angle . . . . . 45°



## 2B•2 Engine removal and overhaul procedures

---

### Valve springs

Valve spring free length:

85H and 99H .....	44.45 mm
10H .....	49.70 mm
12H:	
1275 GT .....	49.70 mm
Cooper S Mk III outer spring .....	44.19 mm
Cooper S Mk III Inner spring .....	43.31 mm
12A .....	49.53 mm

### Camshaft and camshaft bearings

Camshaft journal diameter:

Front .....	42.304 to 42.316 mm
Centre .....	41.218 to 41.231 mm
Rear .....	34.857 to 34.887 mm

Bearing inside diameter (reamed after fitting):

85H:	
Front .....	42.342 to 42.355 mm
Centre .....	41.262 to 41.288 mm
Rear .....	34.908 to 34.938 mm
99H and 10H:	
Front .....	42.342 to 42.355 mm
Centre .....	41.225 to 41.267 mm
Rear .....	34.912 to 34.925 mm
12H and 12A:	
Front .....	42.342 to 42.355 mm
Centre .....	41.262 to 41.288 mm
Rear .....	34.908 to 34.938 mm

Bearing running clearance:

85H:	
Front .....	0.012 to 0.051 mm
Centre and rear .....	0.031 to 0.069 mm
All other engines:	
Front, centre and rear .....	0.025 to 0.051 mm

Camshaft endfloat .....

0.076 to 0.178 mm

### Cylinder block

Bore diameter:

85H .....	62.94 mm
99H .....	64.59 mm
10H .....	64.59 mm
12H and 12A .....	70.61 mm

Maximum cylinder bore oversize (after reborings):

85H and 99H .....	+1.02 mm
All other engines .....	+0.51 mm

Maximum cylinder bore/liner taper\* .....

0.10 mm

Maximum cylinder bore/liner ovality\* .....

0.10 mm

*\*These are suggested figures, typical for this type of engine - no exact values are stated by Rover.*

### Pistons

Piston-to-bore clearance:

85H:	
Top of skirt .....	0.066 to 0.81 mm
Bottom of skirt .....	0.015 to 0.030 mm
99H and 10H:	
Top of skirt .....	0.060 to 0.085 mm
Bottom of skirt .....	0.010 to 0.026 mm
12H:	
Top of skirt:	
1275 GT .....	0.070 to 0.114 mm
Cooper S Mk III .....	0.063 to 0.072 mm
Bottom of skirt:	
1275 GT .....	0.031 to 0.056 mm
Cooper S Mk III .....	0.048 to 0.063 mm
12A:	
Top of skirt .....	0.074 to 0.114 mm
Bottom of skirt .....	0.023 to 0.064 mm

Piston oversizes available:

85H and 99H .....	+0.254 mm, +0.508 mm, +0.762 mm, +1.02 mm
All other engines .....	+0.254 mm, +0.508 mm,

## Piston rings

Piston ring end gap:	
85H and 99H .....	0.178 to 0.305 mm
10H:	
Compression rings .....	0.178 to 0.305 mm
Oil control ring:	
Rails .....	0.305 to 0.711 mm
Side springs .....	2.54 to 3.81 mm
12H:	
Top compression ring:	
1275 GT .....	0.28 to 0.41 mm
Cooper S Mk III .....	0.20 to 0.33 mm
2nd and 3rd compression rings .....	0.20 to 0.33 mm
Oil control ring:	
1275 GT .....	0.254 to 1.02 mm
Cooper S Mk III .....	0.20 to 0.33 mm
12A:	
Top compression ring .....	0.25 to 0.45 mm
Second compression ring .....	0.20 to 0.33 mm
Oil control ring .....	0.38 to 1.04 mm
Ring-to-groove clearance (compression rings) .....	0.038 to 0.089 mm

## Crankshaft

Main bearing journal diameter:	
85H, 99H* and 10H .....	44.46 to 44.47 mm
12H:	
1275 GT .....	50.83 to 50.84 mm
Cooper S Mk III .....	50.81 to 50.82 mm
12A:	
No colour code .....	50.83 to 50.84 mm
Red colour code .....	50.81 to 50.82 mm
Green colour code .....	50.82 to 50.83 mm
Yellow colour code .....	50.83 to 50.84 mm
Minimum main bearing journal regrind diameter:	
85H, 99H* and 10H .....	43.45 mm
12H:	
1275 GT .....	49.78 mm
Cooper S Mk III .....	50.30 mm
12A .....	50.32 mm
Main bearing running clearance:	
85H, 99H* and 10H .....	0.025 to 0.068 mm
12H and 12A .....	0.017 to 0.058 mm
Big-end bearing journal diameter:	
85H, 99H* and 10H .....	41.28 to 41.29 mm
12H and 12A .....	44.44 to 44.46 mm
Minimum big-end journal regrind diameter:	
85H, 99H* and 10H .....	40.27 mm
12H .....	43.44 mm
12A .....	43.93 mm
Big-end bearing running clearance:	
85H, 99H* and 10H .....	0.025 to 0.063 mm
12H and 12A .....	0.038 to 0.081 mm
Crankshaft endfloat .....	0.051 to 0.076 mm

\*Refer to a Rover dealer for information on later models

## Lubrication system

Oil pump shaft and rotor endfloat .....	0.127 mm
Oil pump rotor lobe clearance .....	0.152 mm
Oil pump rotor-to-body clearance .....	0.254 mm
Oil pump relief pressure .....	4.2 bars
Oil pressure:	
Running .....	4.2 bars
Idling .....	1.0 bar
Pressure relief valve spring:	
Free length .....	72.63 mm
Fitted length .....	54.77 mm

<b>Torque wrench settings</b>	<b>Nm</b>	<b>lbf ft</b>
Connecting rod big-end:		
Bolts .....	50	37
Nuts .....	45	33
Flywheel centre bolt .....	152	112
Flywheel housing nuts and bolts .....	25	18
Transmission casing to engine .....	8	6
Converter centre bolt .....	152	112
Converter (six central bolts) .....	29	21
Converter housing nuts and bolts .....	25	18
Gudgeon pin clamp bolt .....	32	24
Main bearing bolts .....	85	63
Timing cover and front plate:		
$\frac{1}{4}$ in UNF bolts .....	7	5
$\frac{3}{8}$ in UNF bolts .....	16	12
Oil pump bolts .....	11	8
Oil filter housing nuts .....	19	14
Oil pipe banjo union .....	52	38
Oil pressure relief valve nut .....	59	43
Tappet side covers .....	4.7	3.5

## 1 General information

Included in this Part of Chapter 2 are details of removing the engine/transmission from the car and general overhaul procedures for the cylinder head, cylinder block and all other engine internal components.

The information given ranges from advice concerning preparation for an overhaul and the purchase of replacement parts, to detailed step-by-step procedures covering removal, inspection, renovation and refitting of engine internal components.

After Section 7, all instructions are based on the assumption that the engine has been removed from the car. For information concerning engine in-car repair, as well as the removal and refitting of those external components necessary for full overhaul, refer to Part A of this Chapter and to Section 7. Ignore any preliminary dismantling operations described in Part A that are no longer relevant once the engine has been removed from the car.

## 2 Engine/transmission removal - preparation and precautions

If you have decided that an engine must be removed for overhaul or major repair work, several preliminary steps should be taken.

Locating a suitable place to work is extremely important. Adequate work space, along with storage space for the car, will be needed. If a workshop or garage is not available, at the very least, a flat, level, clean work surface is required.

If possible, clear some shelving close to the work area and use it to store the engine components and ancillaries as they are removed and dismantled. In this manner the

components stand a better chance of staying clean and undamaged during the overhaul. Laying out components in groups together with their fixing bolts, screws etc will save time and avoid confusion when the engine is refitted.

Clean the engine compartment and engine/transmission before beginning the removal procedure; this will help visibility and help to keep tools clean.

The help of an assistant should be available; there are certain instances when one person cannot safely perform all of the operations required to remove the engine from the vehicle. Safety is of primary importance, considering the potential hazards involved in this kind of operation. A second person should always be in attendance to offer help in an emergency. If this is the first time you have removed an engine, advice and aid from someone more experienced would also be beneficial.

Plan the operation ahead of time. Before starting work, obtain (or arrange for the hire of) all of the tools and equipment you will need. Access to the following items will allow the task of removing and refitting the engine/transmission to be completed safely and with relative ease: an engine hoist - rated in excess of the combined weight of the engine/transmission, a heavy-duty trolley jack, complete sets of spanners and sockets as described at the rear of this manual, wooden blocks, and plenty of rags and cleaning solvent for mopping up spilled oil, coolant and fuel. A selection of different sized plastic storage bins will also prove useful for keeping dismantled components grouped together. If any of the equipment must be hired, make sure that you arrange for it in advance, and perform all of the operations possible without it beforehand; this may save you time and money.

Plan on the vehicle being out of use for quite a while, especially if you intend to carry out an engine overhaul. Read through the

whole of this Section and work out a strategy based on your own experience and the tools, time and workspace available to you. Some of the overhaul processes may have to be carried out by a Rover dealer or an engineering works - these establishments often have busy schedules, so it would be prudent to consult them before removing or dismantling the engine, to get an idea of the amount of time required to carry out the work.

When removing the engine from the vehicle, be methodical about the disconnection of external components. Labelling cables and hoses as they are removed will greatly assist the refitting process.

Always be extremely careful when lifting the engine/transmission assembly from the engine bay. Serious injury can result from careless actions. If help is required, it is better to wait until it is available rather than risk personal injury and/or damage to components by continuing alone. By planning ahead and taking your time, a job of this nature, although major, can be accomplished successfully and without incident.

There are two methods of engine removal. The engine can be removed from under the car, complete with subframe, or the engine can be lifted out through the bonnet aperture. In either instance the engine is removed complete with the transmission, and also the radiator.

It is easier to lift the engine/transmission assembly out of the engine compartment with the aid of a suitable hoist than to separate the subframe from the body, and lift the body up, using the rear wheels as a pivot. This is especially so with Hydrolastic models. The subframe comprises the frame itself, the wheels, brakes, driveshafts, hubs, and suspension, complete except for shock absorbers.

In either case, it is necessary to raise and support the front of the car so that it can be worked on from underneath.

### 3 Engine/transmission - removal and refitting



#### Removal

- 1 Disconnect the battery negative lead.
- 2 Drain the cooling system and the engine/transmission oil as described in Chapter 1.
- 3 Remove the bonnet and front grille as described in Chapter 11.
- 4 On models equipped with an ignition shield mounted on the front of the engine, release the three retaining lugs and lift off the shield.
- 5 On carburettor engines, refer to Chapter 4A and remove the air cleaner assembly and carburettor(s). On fuel injection engines, slacken the accelerator cable locknuts, and free the outer cable from its mounting bracket. Release the inner cable from the throttle cam, and position the cable clear of the throttle body.
- 6 On fuel injection engines, remove the engine management ECU as described in Chapter 4B.
- 7 Remove the starter motor and alternator as described in Chapter 5A.
- 8 Where applicable, undo and remove the screws securing the starter solenoid to the inner wing panel and position the solenoid clear of the engine.
- 9 On models equipped with a mechanical fuel pump, disconnect the fuel inlet hose and plug it with a suitable bolt or metal rod to prevent loss of fuel.
- 10 On fuel injection engines, undo the bolt and remove the retaining clip securing the injector housing fuel pipes to the bulkhead. Bearing in mind the information contained in Chapter 4B, Section 6, concerning depressurisation of the fuel system, using an open-ended spanner to retain each adapter, slacken the union nuts and disconnect the feed and return pipes from the throttle body assembly. Plug each pipe and adapter, to minimise the loss of fuel and prevent the entry of dirt into the system.
- 11 Where applicable, disconnect the cooling system hose from the expansion tank, which is located by the side of the radiator. Undo the retaining bolt and remove the expansion tank from the engine compartment.
- 12 On carburettor engines, slacken the retaining clips and remove the two heater hoses. Also slacken the two securing screws and withdraw the heater control cable from the valve on the cylinder head (where applicable). On fuel injection engines, Undo the heater control coolant valve mounting bolt, then slacken the retaining clips and disconnect the coolant valve hoses from the manifold and thermostat housing. Slacken the clip and disconnect the heater unit hose from its union with the bottom radiator hose (situated directly below the coolant valve).
- 13 If a fresh air heater/demister blower motor is mounted in the engine compartment, remove this unit as described in Chapter 3.
- 14 Undo and remove the two nuts and bolts on the clamp, or the three flange nuts securing the exhaust front pipe to the manifold. Separate the front pipe from the manifold. **Note:** *On Cooper S models it will be necessary to remove the complete exhaust system as described in Chapter 4C.*
- 15 If the horn is mounted on the front body panel, disconnect the electrical leads, undo and remove the mounting bolts and withdraw the horn.
- 16 From beneath the right-hand front wing detach the heater fresh air ducting from the air inlet. Now withdraw the air inlet from the inner wing panel.
- 17 Disconnect the wiring from the following locations, after identifying the leads or wiring plugs for subsequent reconnection:
  - a) *Leads to the temperature gauge transmitter and oil pressure switch (where fitted).*
  - b) *LT leads at the ignition coil.*
  - c) *HT leads from the spark plugs and ignition coil, and the crankshaft sensor wiring connector on fuel injection engines.*
  - d) *On fuel injection engines, disconnect the wiring connectors from the injector housing, the throttle potentiometer and the stepper motor. Free the wiring from any relevant retaining clips, and position it clear of the throttle body assembly. Trace the wiring back from the exhaust system lambda sensor (which is screwed into the exhaust manifold), releasing it from any relevant cable-ties, and disconnect its wiring connector from the main harness.*
  - e) *Wiring connectors from the auxiliary cooling fan switch (where fitted), which is situated at the front bottom corner of the radiator.*
- 18 Spring back the distributor cap retaining clips, or undo the two screws and remove the cap and leads. Remove the rotor arm from the distributor shaft.
- 19 On manual transmission models, release the clutch slave cylinder return spring from the clutch operating lever. Undo and remove the two securing bolts and lift the slave cylinder off the flywheel housing. Tie the cylinder out of the way from a convenient place on the engine bulkhead.
- 20 If an oil pressure gauge is fitted, slacken the clamp screw and pull the rubber hose off the feed pipe at the rear of the engine.
- 21 On fuel injection engines, release the retaining clip and disconnect the vacuum hose from the pipe situated just behind the thermostat housing. Disconnect the two vacuum hoses from the rear of the inlet manifold, noting their correct fitted positions; note that the hoses are colour-coded for identification purposes.
- 22 On later models, disconnect the oil separator breather hose from the right-hand end of the cylinder head. Undo the two bolts securing the separator to the flywheel housing, and remove the separator and hose assembly from the engine, along with its gasket.
- 23 Undo and remove the bolt securing the engine tie-bar to the side of the cylinder block. Slacken the tie-bar bulkhead mounting and move the bar back out of the way. Note that on later models the tie-bar retaining bolt also retains the engine earth strap.
- 24 Where fitted, remove the oil cooler as described in Part A of this Chapter.
- 25 On models fitted with a vacuum servo unit mounted in the engine compartment, refer to Chapter 9 and remove the servo and brake master cylinder. Unscrew the two union nuts securing the master cylinder brake pipes to the pressure-reducing valve, and remove both the pipes, noting their correct fitted positions. Plug the pressure reducing valve ports, to minimise fluid loss and prevent the entry of dirt into the system.
- 26 Working under the front wheel arch undo and remove the screw securing the upper suspension arm rebound rubber to the subframe and withdraw the rubber. Place a solid wooden wedge of approximately the same thickness in its place. Repeat this procedure on the other side of the car.
- 27 Chock the rear wheels then jack up the front of the car and support it on axle stands (see "Jacking and vehicle support"). Remove the front roadwheels.
- 28 On manual transmission models fitted with a direct engagement gear lever, undo and remove the retaining screws and lift off the interior rubber boot retaining plate. Now slide the rubber boot up the gear lever slightly. From under the car, undo and remove the two bolts securing the gear lever retaining plate to the rear of the differential housing. Withdraw the gear lever into the car and lift out the anti-rattle spring and plunger from the gear lever housing.
- 29 On manual transmission models fitted with the early type remote control extension housing, undo and remove the four shouldered bolts securing the housing to the mounting on the rear of the differential assembly. Pull the front of the extension housing downwards to disengage the linkage and then support the front of the housing on a block of wood.
- 30 On manual transmission models fitted with the later rod-change type remote control extension housing, drift out the roll pin securing the collar of the remote control extension rod to the selector shaft. Undo and remove the bolt securing the fork of the steady rod to the differential housing. Release the extension rod and the steady rod from the rear of the transmission.
- 31 On automatic transmission models, disconnect the gear selector cable from the transmission as described in Chapter 7B, Section 6.
- 32 On early models undo and remove the bolt securing the engine earth strap to the flywheel/torque converter housing.





3.44a Lift the engine/transmission out of the engine bay . . .



3.44b . . . until sufficient clearance exists to disconnect the speedometer cable

**33** Undo and remove the nut securing the steering tie-rod balljoint to the steering arm on each side of the car. Release the balljoint tapers using a universal separator.

**34** Undo and remove the nut securing the front suspension swivel hub balljoint to the upper suspension arm on each side of the car. Release the balljoint shanks from the upper suspension arms using universal balljoint separator. Move the top of the two swivel hubs outwards and allow them to hang in this position. Take care not to strain the flexible brake hoses excessively.

**35** On early models equipped with rubber couplings at the inner end of each driveshaft, undo and remove the two U-bolt locknuts securing each coupling to the differential driving flanges. Withdraw the two U-bolts from each side and move the driveshafts away from the differential.

**36** On later models equipped with offset sphere joints at the inner end of each driveshaft, release the joints from the differential using Rover special tool 18G1240. If this tool cannot be obtained, it is possible to withdraw the joints using a tyre lever or similar tool pivoting against the end cover retaining bolt directly below the joint. Once the joints have been released, move the driveshafts away from the differential as far as possible.

**37** On Cooper S and certain automatic transmission models, undo and remove the four nuts securing each universal joint flange to the differential driving flanges. Move the driveshafts away from the differential to separate the flanges.

**38** On all models undo and remove the nut and bolt securing the exhaust pipe strap to the bracket on the side of the differential housing.

**39** Undo and remove the nut and bolt securing the lower engine tie-bar to the bracket on the transmission casing. Slacken the nut and bolt securing the other end and remove the tie-bar clear of the transmission.

**40** Position a crane or hoist over the engine and attach chains or ropes either to brackets bolted to the cylinder head or around each end of the transmission casing.

**41** With the lifting gear in position, raise it slightly and just take the weight of the engine.

**42** Undo and remove the two nuts and bolts securing the two engine mountings to the side of the front subframe.

**43** Make a final check that all cables, pipes and hoses have been disconnected and that all removed parts are clear of the engine.

**44** The engine/transmission can now be lifted out. Tilt it backwards as it is lifted out to allow the differential to clear the rear of the subframe. When the unit is halfway out or when sufficient clearance exists, unscrew the speedometer cable knurled retaining nut and lift the cable off the housing (**see illustrations**). On fuel injection engines, disconnect the wiring connectors from the PTC heater and coolant temperature sensor situated on the underside of the inlet manifold. Release the wiring harness from any relevant retaining clips.

**45** Now completely remove the power unit from the vehicle and position it on a bench or clean floor for separation (**see illustration**).

### Refitting

**46** Refitting is the reverse sequence to removal, following where necessary the instructions given in the other Chapters of this manual. Note the following additional points:

- a) Tighten all nuts and bolts to the specified torque wrench settings (where given).
- b) On models fitted with offset sphere inner driveshaft joints, ensure that the joint circlips are properly located in their grooves, then apply a smear of graphite-based grease to the splines, and locate the joints in the transmission. Push them firmly into position, and check they are securely retained by the circlips.
- c) Ensure that all wiring harnesses are properly routed, and are retained by any

necessary cable-ties or clips.

- d) On automatic transmission models, adjust the selector cable as described in Chapter 7B, Section 6.
- e) On models fitted with a vacuum servo unit, refit the brake master cylinder as described in Chapter 9.
- f) Tighten all hose clips securely, and refill the cooling system as described in Chapter 1.
- g) Fit a new oil filter and fill the engine with fresh oil as described in Chapter 1.
- h) On completion, reconnect the battery, and adjust the accelerator cable as described in Chapter 4A or B as applicable.

## 4 Engine/transmission (with front subframe) - removal and refitting



**Note:** After disconnecting all the relevant components, the body can be lifted up at the front by four strong people and wheeled away, or the body can be lifted by block and tackle and the engine/transmission and subframe assembly rolled out from underneath. When working on cars equipped with Hydrolastic suspension, it will be necessary to have the system depressurised by a Rover dealer before commencing the removal procedure (see Chapter 10 Section 2).

### Removal

**1** Begin by carrying out paragraphs 1 to 24, and 27 to 33 inclusive of the previous Section, ignoring references to manual or automatic transmission where these are not applicable.

**2** Refer to Chapter 4C if necessary and remove the complete exhaust system from the car.

**3** Undo and remove the knurled nut securing the speedometer cable to its housing on the left-hand side of the transmission. Withdraw the cable from the housing.

4 Remove the brake master cylinder filler cap and place a piece of polythene over the filler neck. Now securely refit the cap. This will help prevent loss of fluid when the hydraulic pipes are disconnected.

5 On models equipped with a single line braking system undo and remove the brake hydraulic pipe to the front wheels at the three-way connector on the bulkhead. Where a dual line or split braking system is fitted, undo and remove the hydraulic pipes to the front wheels at the pressure differential warning actuator or the pressure reducing valve according to system type. In all cases plug or tape over the pipe ends after removal to prevent dirt ingress.

6 If the brake lights are operated by a hydraulic pressure switch, disconnect the electrical leads at the switch, which is located on the right-hand side of the subframe.

7 Slacken the clip and detach the brake servo vacuum hose (where fitted) at the union on the inlet manifold.

8 On models fitted with rubber cone suspension, remove the front shock absorbers as described in Chapter 10.

9 On cars fitted with Hydrolastic suspension, undo and remove the displacer unit hoses at the transfer pipe unions.

10 Now refit the roadwheels and lower the car to the ground.

11 From inside the car lift up the carpets and undo and remove the two bolts each side securing the rear of the subframe or subframe mounting to the floor.

12 At the front of the car undo and remove the bolt that secures each side of the subframe or subframe mounting to the body.

13 On early models knock back the locking plate tabs from the two bolts (or nuts) on either side of the engine compartment which secure the subframe towers to the bulkhead crossmember.

14 Now undo and remove the bolts or nuts. On later models undo and remove the large hexagon-headed plug that is fitted in place of the early bolt or stud mounting.

15 Make a final check that all cables, pipes and hoses have been disconnected and that all removed parts are clear of the engine and subframe.

16 Support the front of the subframe and the rear of the transmission casing with blocks of wood or jacks and lift the body at the front until it is clear of the engine. Take care that all components are clear when lifting the body and ensure that the radiator matrix is not damaged.

17 Now wheel the body away from the subframe or roll the subframe out from underneath, whichever is more convenient.

### Refitting

18 Refitting is the reverse sequence to removal, following where necessary the instructions given in the other Chapters of this manual. Note the following additional points:

- a) Tighten all nuts and bolts to the specified torque wrench settings (where given).

- b) Ensure that all wiring harnesses are properly routed, and are retained by any necessary cable-ties or clips.
- c) Adjust the accelerator cable as described in Chapter 4A or B as applicable.
- d) On automatic transmission models, adjust the selector cable as described in Chapter 7B, Section 6.
- e) Tighten all hose clips securely, and refill the cooling system as described in Chapter 1.
- f) Fit a new oil filter and fill the engine with fresh oil as described in Chapter 1.
- g) Bleed the brake hydraulic system on completion as described in Chapter 9. Where Hydrolastic suspension is fitted it will be necessary to have the system repressurised by a Rover dealer



5.3 Removing the flywheel housing cover

engine/transmission on the bench and proceed as follows.

2 If not already done, drain the engine/transmission oil as described in Chapter 1.

3 Undo and remove the retaining bolts and lift off the flywheel housing cover and, if still in place, the starter motor (see illustration).

4 Where applicable, withdraw the wire retaining clips and lift away the clutch thrust plate from the centre of the diaphragm spring housing (see illustration).

5 Rotate the flywheel until the timing marks on the flywheel periphery are at approximately the 3 o'clock position. This will prevent the primary gear retaining U-shaped washer from becoming dislodged as the flywheel is removed.

## 5 Engine and manual transmission - separation and reconnection

### Separation

1 Remove the engine/transmission assembly from the car as described in Section 3. Alternatively, if the unit has been removed complete with front subframe, undo the engine/transmission mounting attachments and lift the assembly from the subframe using suitable lifting tackle. Position the

5.4 Clutch thrust plate and flywheel securing bolt assemblies

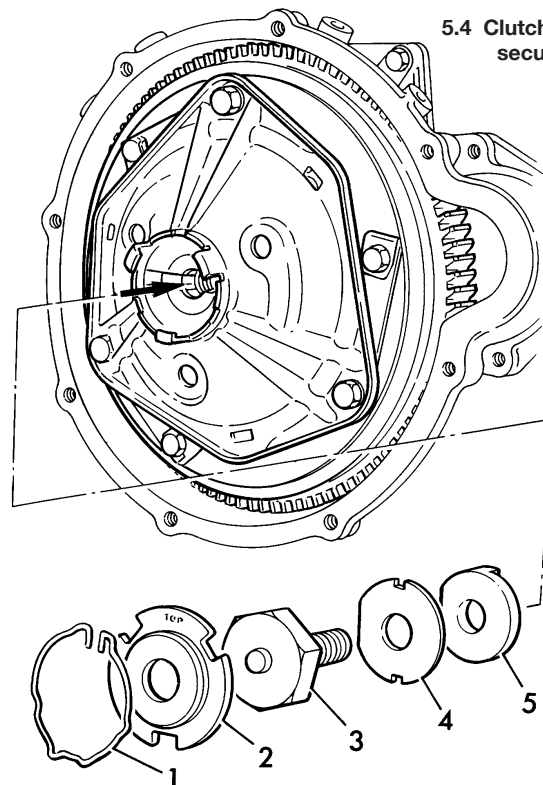

- 1 Circlip
- 2 Release bearing thrust plate
- 3 Flywheel retaining bolt
- 4 Lockwasher
- 5 Keyed washer

H 15889

**6** Using a punch or small chisel, knock back the lockwasher securing the large flywheel retaining bolt in the centre of the flywheel.

**7** With a large socket and extension handle, undo and remove the flywheel retaining bolt. Insert a screwdriver between the flywheel ring gear teeth and housing to prevent the flywheel from turning while the bolt is removed. Also have an assistant support the engine, as this bolt will be tight requiring considerable leverage to remove it. When the bolt is removed, prise out the keyed locating washer from the end of the flywheel and crankshaft.

**8** Where the bolt which retains the flywheel to the crankshaft has been secured with thread-locking compound or an encapsulated type of bolt is used, then prior to refitting, all threads in the crankshaft must be thoroughly cleaned. Preferably, this should be done by using a tap of the appropriate size. Discard the old retaining bolt, and use only a new encapsulated bolt incorporating a thread-locking compound patch on refitting.

**9** The flywheel is a taper fit on the end of the crankshaft and a special puller will be needed to remove it. This puller is Rover special tool 18G304 and adapter 18G304M for models without the later type verito clutch assembly, or 18G1381 for models with a verito type clutch (see Chapter 6 for identification of the two clutch types, if necessary). Note that there are a number of similar pullers readily obtainable from accessory shops or tool hire outlets if the manufacturer's tool is not available (see illustration).

**10** Position the puller with the three studs or bolts inserted through the holes in the spring

housing (non-verto type) and screwed into the flywheel securely. Do not tighten the studs/bolts or the clutch disc may be damaged. Fit the thrust pad of the puller to the end of the crankshaft and then tighten the puller centre bolt. Prevent the flywheel from turning using a screwdriver inserted into the ring gear teeth.

**11** Continue tightening the centre bolt of the puller until the flywheel breaks free from the taper. It is quite likely that the flywheel will be extremely tight requiring a great deal of effort to free it. If this is the case sharply strike the puller centre bolt with a medium hammer. This should "shock" the flywheel off the taper. Take care when doing this as the flywheel may spring off and land on your feet!

**12** Once the taper is released the complete clutch and flywheel assembly can be lifted off the end of the crankshaft.

**13** With the flywheel and clutch removed the flywheel housing can be separated from the engine/transmission casing as follows.

**14** If a breather is fitted to the top of the housing undo and remove the retaining bolts and lift off the breather assembly.

**15** Knock back the tabs on the lockwashers inside the housing.

**16** Undo and remove the nine nuts from the studs on the transmission casing (see illustration).

**17** Undo and remove the six bolts from the cylinder block. Note the positions from which the shorter bolts are removed.

**18** The housing can now be carefully pulled off. Note that as the housing is withdrawn a small quantity of oil will be released so have some old rags or a small container handy.



**5.9 Using a commercially available puller to release the flywheel taper**

**19** With the flywheel and flywheel housing removed, undo and remove the flange nuts, bolts and spring washers securing the engine to the transmission.

**20** Undo and remove the bolts securing the radiator lower mounting bracket to the engine mounting bracket.

**21** Using a crane, or hoist and lifting slings, carefully lift the engine off the transmission casing. It may be necessary to tap the transmission casing downwards with a rubber or hide mallet to break the seal between the two mating faces.

**22** With the engine removed, cover the top of the transmission to prevent dirt ingress.

### Reconnection

**Note:** Before reconnecting the engine and transmission, refer to Chapter 7A, Section 6 and adjust the endfloat of the transfer gears (primary gear and idler gear). Then proceed as described below.

**23** Carefully scrape away any remaining traces of old gasket from the engine/transmission mating faces and flywheel housing joint.

**24** Lightly smear the upper sides of the engine/transmission joint gaskets with jointing compound and place them in position on the engine mating face.

**25** Apply a bead of RTV sealant to all the mating surfaces of the front oil seal, then place seal in position between the front main bearing cap and engine front plate (see illustration).



**5.25 Fitting a new front oil seal . . .**

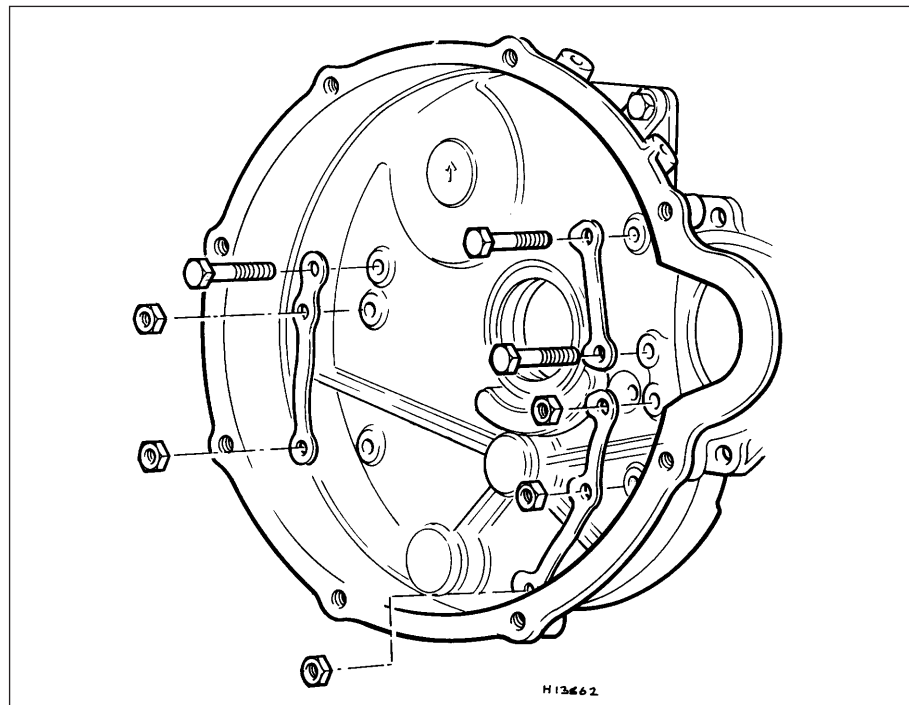

**5.16 Flywheel housing attachments**





**5.26** ... and a new O-ring to the transmission casing joint face

**26** Locate the oil supply O-ring into its groove in the transmission casing face, and if necessary retain it in place with a trace of grease (see illustration).

**27** Using suitable lifting gear and with the help of an assistant, carefully lower the engine onto the transmission casing. Have your assistant guide the engine, and lower it very slowly, as it is easy to dislodge the gaskets.

**28** With the engine in position, refit and fully tighten the retaining nuts, bolts and spring washers, and refit the radiator lower mounting bolts.

**29** Refit the primary gear thrustwasher to the end of the crankshaft with its chamfered side toward the crankshaft flange (see illustration).

**30** Slide on the primary gear (see illustration) and then turn the crankshaft until No 1 piston at TDC (refer to Part A, Section 3).

**31** Refit the primary gear retaining ring and then secure the assembly in position with the C-shaped washer (see illustrations).

**32** Refit the idler gear to its bearings in the transmission casing, turning it slightly to mesh with the other two gears as it is installed. Ensure that both the thrustwashers are in position, one each side of the idler gear: if the later type gear is being fitted, the longer boss goes toward the transmission casing.

**33** Place a new joint gasket over the studs on the transmission casing.

**34** Before fitting the flywheel housing, make sure that a new flywheel housing oil seal has been fitted (see Part A, Section 9), and cover the splines of the primary gear with the



**5.29** Position the primary gear thrustwasher on the crankshaft

special thin sleeve of Rover special tool 18G570. Alternatively, wrap tin foil or masking tape tightly over the splines to avoid damaging the seal. Lubricate the lip of the oil seal prior to fitting.

**35** Carefully refit the flywheel housing, taking care that the rollers on the first motion shaft bearing enter their outer race squarely. On no account force the housing. If it does not easily push fully home, turn the bearing slightly and try again. Two or three attempts may be needed (see illustration).

**36** Refit new locking tabs, followed by the housing retaining nuts and bolts to their correct locations. Tighten the fixings to the specified torque and bend over the locktabs.

**37** Carefully clean the mating tapers in the flywheel and on the end of the crankshaft, and make quite certain there are no traces of oil, grease, or dirt present.

**38** Refit the flywheel on the end of the crankshaft with the 1/4 TDC markings at the top and then refit the driving washer which positively locates the flywheel.

**39** Fit a new lockwasher under the head of the flywheel securing bolt. Remember to use only a new encapsulated bolt incorporating a thread-locking compound if that type of bolt was removed. Insert the bolt in the centre of the flywheel and tighten it to the specified torque.

**40** Tap down the side of the lockwasher against the driving plate, and tap up the other side of the washer against the retaining bolt head.

**41** Refit the thrust plate and secure it in position with the circular retaining spring.

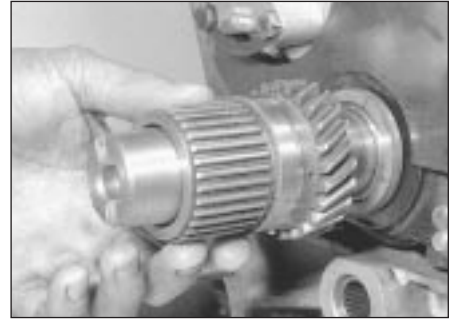

**5.30** Slide on the primary gear ...

**42** Now refit the flywheel housing cover and fully tighten the retaining bolts. Refit the starter motor if appropriate at this stage.

**6 Engine and automatic transmission - separation and reconnection**



**Separation**

**1** Remove the engine/transmission assembly from the car as described in Section 3. Alternatively, if the unit has been removed complete with front subframe, undo the engine/transmission mounting attachments and lift the assembly from the subframe using suitable lifting tackle. Position the engine/transmission on the bench and proceed as follows.

**2** If not already done, drain the engine/transmission oil as described in Chapter 1.

**3** Undo and remove the retaining bolts and lift off the torque converter housing cover and, if still in place, the starter motor.

**4** Undo and remove the retaining nuts and bolts and take off the converter housing cover.

**5** Undo and remove the five retaining bolts and lift off the low pressure valve assembly from its location beneath the torque converter (see illustration).

**6** Using a socket and bar, undo and remove the converter input gear retaining nut. Use a large screwdriver inserted through the hole in the top of the converter housing and engaged with the ring gear teeth to prevent the torque converter from turning.



**5.31a** ... followed by the retaining ring ...



**5.31b** ... and the C-shaped washer



**5.35** Refitting the flywheel housing



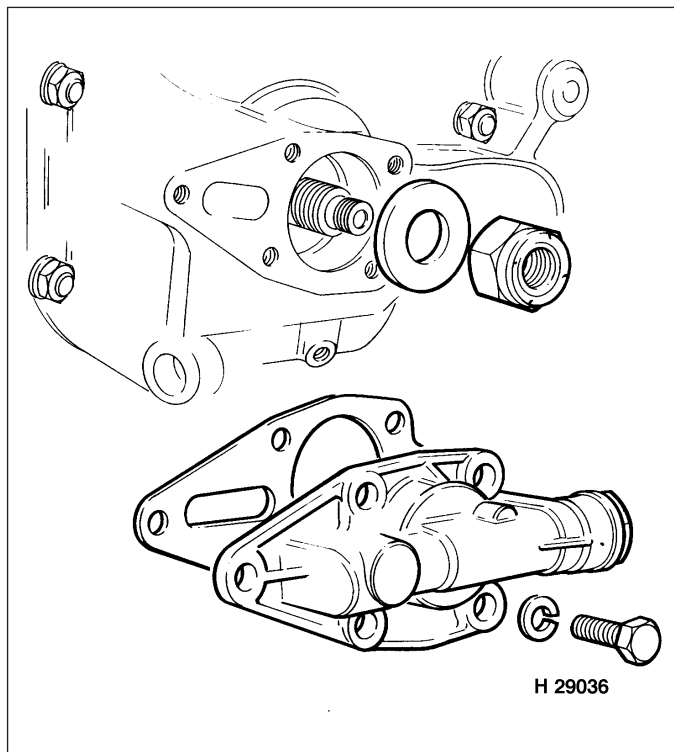

6.5 Low pressure valve assembly and input gear retaining nut - automatic transmission models

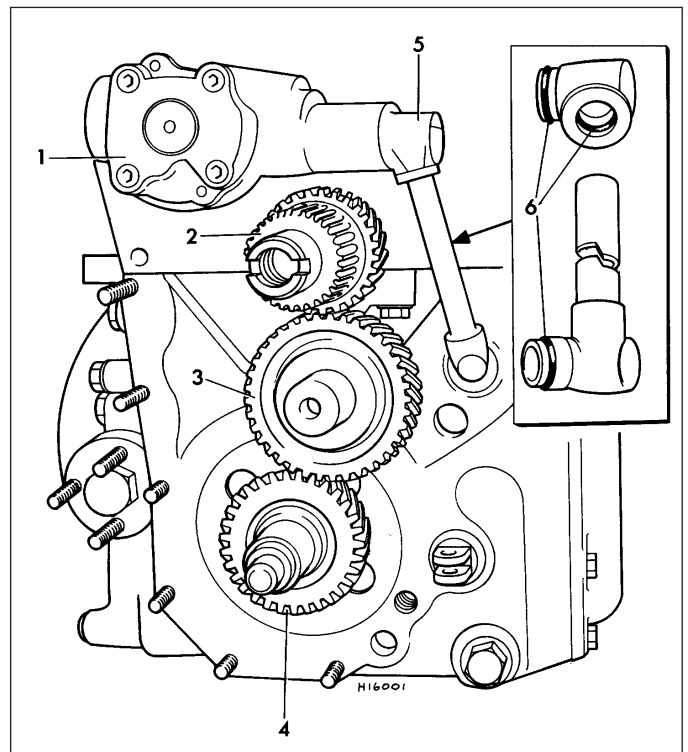

6.14 End view of the automatic transmission transfer gears with the converter housing removed

- |                         |                 |
|-------------------------|-----------------|
| 1 Main oil pump         | 4 Input gear    |
| 2 Converter output gear | 5 Oil feed pipe |
| 3 Idler gear            | 6 Sealing rings |

**7** Knock back the locktabs, and undo and remove three equally spaced bolts from the centre of the converter. Leave the other three bolts in position.

**8** Knock back the lockwasher securing the large converter centre retaining bolt. Using a large socket and bar, undo and remove the torque converter centre bolt. Use a screwdriver as previously described to prevent the converter from turning.

**9** Rotate the crankshaft until the timing marks on the converter periphery are at approximately the 3 o'clock position.

**10** The torque converter is a taper fit on the end of the crankshaft and it will be necessary to obtain Rover special tool 18G1086 to remove it. The tool is bolted to the torque converter through the holes of the three previously removed converter retaining bolts. With the adapter in position on the end of the crankshaft, tighten the tool centre bolt until the torque converter breaks free of the taper, and then lift it off the crankshaft.

**11** Undo and remove the nuts, bolts and washers securing the converter housing to the engine and transmission casing.

**12** Remove the selector bellcrank lever clevis pin and nut, and lift off the bellcrank lever. Remove the bellcrank lever pivot.

**13** The converter housing can now be carefully withdrawn.

**14** With the torque converter and housing removed, carefully lever the main oil feed pipe from the transmission and oil pump (see illustration).

**15** Undo and remove the two retaining bolts and lift off the oil filter and housing assembly.

**16** Unscrew the engine oil feed pipe union at the adapter on the transmission casing.

**17** Undo and remove the flange nuts, bolts and spring washers securing the engine to the transmission.

**18** Undo and remove the bolts securing the radiator lower mounting bracket to the engine mounting adapter.

**19** Using a crane, or hoist and lifting slings, carefully lift the engine off the transmission casing. It may be necessary to tap the transmission casing downward with a rubber or hide mallet to break the seal between the two mating faces.

**20** With the engine removed cover the top of the transmission completely to prevent dirt ingress.

### Reconnection

**Note:** Before reconnecting the engine and transmission, the endfloat of the transfer gears (primary gear and idler gear) must be adjusted. The procedure is the same as for manual transmission models and is described in Chapter 7A, Section 6. With the endfloat adjusted, proceed as described below.

**21** Carefully scrape away any remaining traces of old gasket from the engine/transmission mating faces and flywheel housing joint.

**22** Lightly smear the upper sides of the engine/transmission joint gaskets with jointing compound and place them in position on the engine mating face.

**23** Apply a bead of RTV sealant to all the mating surfaces of the front oil seal, then place seal in position between the front main bearing cap and engine front plate.

**24** Using suitable lifting gear and with the help of an assistant, carefully lower the engine onto the transmission casing. Have your assistant guide the engine, and lower it very slowly, as it is easy to dislodge the gaskets.

**25** With the engine in position, refit and fully tighten the retaining nuts, bolts and spring washers, and refit the radiator lower mounting bolts.

**26** Refit the engine oil feed pipe to the union on the transmission casing.

**27** Place a new gasket in position and refit the oil filter assembly.

**28** Using new O-rings where necessary, carefully push the oil feed pipe into engagement with the oil pump and transmission casing orifice.

**29** Place the converter output gear thrustwasher over the end of the crankshaft, with its chamfered face toward the crankshaft flange.

**30** Now slide on the output gear. Turn the crankshaft until No 1 piston is at TDC (refer to Part A, Section 3) then refit the output gear retaining ring and C-shaped washer.

**31** With the thrustwashers located over each side of the idler gear, insert the gear into its needle roller bearing.

**32** Ensure that the mating faces of the engine/transmission and converter housing are clean, and then position a new gasket over the studs on the transmission.

**33** Before fitting the converter housing, make sure that a new converter housing oil seal has been fitted (see Part A, Section 9), and cover the splines of the converter output gear with the special thin sleeve of Rover special tool 18G1098. Alternatively, wrap tin foil or masking tape tightly over the splines to avoid damaging the seal. Lubricate the lip of the oil seal prior to fitting.

**34** Now carefully refit the converter housing, pushing it squarely home over the transmission casting studs. Refit the retaining nuts and bolts, tightened to the specified torque.

**35** Refit the selector bellcrank lever pivot, lever, clevis pin and nut.

**36** Before fitting the torque converter, it will be first necessary to refit the three central bolts removed to allow the special converter removal tool to be used during dismantling. Then remove each pair of bolts in turn from the converter centre and fit new locking plates. Tighten the six bolts to the specified torque wrench setting and bend over the lock tabs. *On no account remove all six bolts at any one time.* Then, with No 1 and 4 pistons still at the TDC position, slide the torque converter onto the end of the crankshaft, with the timing marks uppermost. Refit the driving collar, a new lockwasher and the retaining bolt. Tighten the retaining bolt to the torque given in the *Specifications*, and then knock back the lockwasher.

**37** Now refit and fully tighten the input gear retaining nut.

**38** Position a new gasket on the transmission casing and refit the low pressure valve assembly.

**39** Finally refit the converter housing cover and the starter motor.

## 7 Engine overhaul - preliminary information

It is much easier to dismantle and work on the engine if it is mounted on a portable engine stand. These stands can often be hired from a tool hire shop.

If a stand is not available, it is possible to dismantle the engine with it suitably supported on a sturdy, workbench or on the floor. Be careful not to tip or drop the engine when working without a stand.

If you intend to obtain a reconditioned engine, all ancillaries must be removed first, to be transferred to the replacement engine (just as they will if you are doing a complete engine overhaul yourself). These components include the following:

- a) *Dynamo/alternator mounting brackets.*
- b) *Engine/transmission mountings and brackets (Part A of this Chapter).*
- c) *Tapet block side covers - where fitted (Section 9).*
- d) *The ignition system and HT components including all sensors, distributor cap and rotor arm, HT leads and spark plugs (Chapters 1 and 5B).*
- e) *Distributor driveshaft (Part A of this Chapter).*
- f) *All electrical switches and sensors.*
- g) *Emission control equipment - where applicable (Chapter 4C).*
- h) *Thermostat and housing, water pump, heater control valve (Chapter 3).*
- i) *Mechanical fuel pump - carburettor engines only (Chapter 4A).*
- j) *Carburettor/fuel injection system components (Chapter 4A and 4B).*
- k) *Inlet and exhaust manifolds (Chapter 4A, 4B and 4C).*
- l) *Oil pump (Section 10).*
- m) *Oil filter housing and delivery pipe (Part A of this Chapter).*
- n) *Oil filter (Chapter 1).*

**Note:** *When removing the external components from the engine, pay close attention to details that may be helpful or important during refitting. Note the fitting positions of gaskets, seals, washers, bolts and other small items.*

If you are obtaining a "short" engine (cylinder block, crankshaft, pistons, camshaft and tappets, and connecting rods all assembled), then the cylinder head, timing chain (together with tensioner, sprockets and cover) will have to be removed also.

If a complete overhaul is planned, the engine can be dismantled in the order given below, referring to Part A of this Chapter unless otherwise stated.

- a) *Inlet and exhaust manifolds (Chapter 4A or 4B).*
- b) *Distributor driveshaft.*
- c) *Timing chain, sprockets and tensioner.*
- d) *Cylinder head.*
- e) *Camshaft and tappets (Section 9).*
- f) *Oil pressure relief valve.*
- g) *Oil filter housing and delivery pipe.*
- h) *Oil pump (Section 10).*
- i) *Piston/connecting rod assemblies (Section 11).*
- j) *Crankshaft (Section 12).*

## 8 Cylinder head - dismantling, cleaning, inspection and reassembly



**Note:** *New and reconditioned cylinder heads are available from the manufacturer, and from engine overhaul specialists. Be aware that some specialist tools are required for the dismantling and inspection procedures, and new components may not be readily available. It may therefore be more practical and economical for the home mechanic to purchase a reconditioned head, rather than dismantle, inspect and recondition the original head.*

### Dismantling

**1** Remove the cylinder head as described in Part A of this Chapter.

**2** If not already done, remove the inlet and exhaust manifolds with reference to the relevant Part of Chapter 4.

**3** With a pair of pliers remove the spring clips (where fitted) holding the two halves of the split collets together.

**4** Using a valve spring compressor, compress each valve spring in turn until the split collets can be removed. Release the compressor, and lift off the spring retainer, valve guide shield (early models) and the spring. Where fitted, slide the oil seal off the valve stem.

**Note:** *On 1275 cc engines the oil seal is positioned over the valve guide. On Cooper S models double valve springs are used. (see illustrations).*

**HAYNES HINT** *If, when the valve spring compressor is screwed down, the spring retainer refuses to free and expose the split collets, gently tap the top of the tool, directly over the retainer, with a light hammer. This will free the retainer.*



**8.4a** Compress the valve springs with a spring compressor and lift off the split collets . . .



**8.4b** . . . Then remove the compressor, valve cap and spring

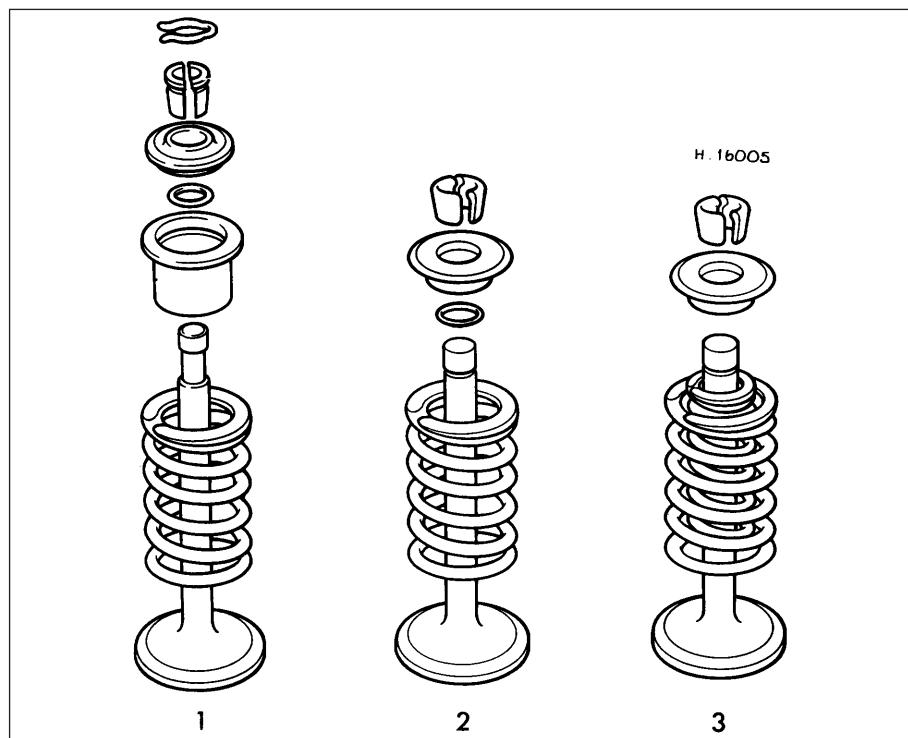

8.4c Valve assembly components

1 Early type

2 Later type

3 Cooper S type

**5** Withdraw the valve through the combustion chamber.

**6** It is essential that each valve is stored together with its collets, retainer and spring(s). The valves should also be kept in their correct sequence, unless they are so badly worn that they are to be renewed. If they are going to be kept and used again, place each valve assembly in a labelled polythene bag or similar small container (see illustration). Note that No 1 valve is nearest to the timing chain end of the engine.

### Cleaning

**7** Thoroughly clean all traces of old gasket material and sealing compound from the cylinder head mating surfaces. Use a suitable cleaning agent together with a putty knife or scraper, taking care not to scratch the head surface.



8.6 Keep all valve components together in a labelled plastic bag

**8** Remove the carbon from the combustion chambers and ports, then clean all traces of oil and other deposits from the cylinder head, paying particular attention to the valve guides and oilways.

**9** Wash the head thoroughly with paraffin or a suitable solvent. Take plenty of time and do a thorough job. Be sure to clean all oil holes and galleries very thoroughly, dry the head completely and coat all machined surfaces with light oil.

**10** Scrape off any heavy carbon deposits that may have formed on the valves, then use a power-operated wire brush to remove deposits from the valve heads and stems.

### Inspection

**Note:** Be sure to perform all the following inspection procedures before concluding that the services of an engineering works are required. Make a list of all items that require attention.

#### Cylinder head

**11** Inspect the head very carefully for cracks, evidence of coolant leakage, and other damage. If cracks are found, a new cylinder head should be obtained.

**12** Use a straight-edge and feeler blade to check that the cylinder head gasket surface is not distorted. If it is, it may be possible to have it machined. Seek the advice of a Rover dealer or engine overhaul specialist if distortion is suspected.

**13** Examine the valve seats in each of the combustion chambers. If they are severely

pitted, cracked, or burned, they will need to be renewed or re-cut by an engine overhaul specialist. If they are only slightly pitted, this can be removed by grinding-in the valve heads and seats with fine valve-grinding compound, as described below.

**14** Check the valve guides for wear by inserting the relevant valve, and checking for side-to-side motion of the valve. A very small amount of movement is acceptable. If the movement seems excessive, remove the valve. Measure the valve stem diameter (see below), and renew the valve if it is worn. If the valve stem is not worn, the wear must be in the valve guide, and the guide must be renewed. The renewal of valve guides is best carried out by a Rover dealer or engine overhaul specialist, who will have the necessary tools available.

**15** If renewing the valve guides, the valve seats should be re-cut or re-ground only after the guides have been fitted.

#### Valves

**16** Examine the head of each valve for pitting, burning, cracks, and general wear. Check the valve stem for scoring and wear ridges. Rotate the valve, and check for any obvious indication that it is bent. Look for pits or excessive wear on the tip of each valve stem. Renew any valve that shows any such signs of wear or damage.

**17** If the valve appears satisfactory at this stage, measure the valve stem diameter at several points using a micrometer (see illustration). Any significant difference in the readings obtained indicates wear of the valve stem. Should any of these conditions be apparent, the valve(s) must be renewed.

**18** In order to reduce oil consumption, valve stem oil seals are fitted to the inlet valves of later 998 cc engines. Fitting of the seals has required the incorporation of modified valves, with cotter grooves nearer the end of the stem. The valve spring seats have also been raised by 1.2 mm.

**19** If renewing any valves, bear in mind that new type valves and seals can be fitted to old type cylinder heads in complete sets only, with the addition of a shim 1.2 mm thick underneath each spring. These shims may also be found already fitted to engines which left the factory with the new type valves and



8.17 Measuring the valve stem diameter



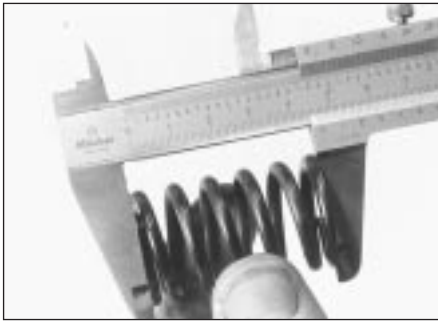

8.25 Measuring valve spring free length

seals in unmodified heads. Consult a Rover dealer for further details of this modification.

**20** If the valves are in satisfactory condition, they should be ground (lapped) into their respective seats, to ensure a smooth, gas-tight seal. If the seat is only lightly pitted, or if it has been re-cut, fine grinding compound *only* should be used to produce the required finish. Coarse valve-grinding compound should *not* be used, unless a seat is badly burned or deeply pitted. If this is the case, the cylinder head and valves should be inspected by an expert, to decide whether seat re-cutting, or even the renewal of the valve or seat insert (where possible) is required.

**21** Valve grinding is carried out as follows. Place the cylinder head upside-down on a bench.

**22** Smear a trace of (the appropriate grade of) valve-grinding compound on the seat face, and press a suction grinding tool onto the valve head. With a semi-rotary action, grind the valve head to its seat, lifting the valve occasionally to redistribute the grinding compound. A light spring placed under the valve head will greatly ease this operation.

**23** If coarse grinding compound is being used, work only until a dull, matt even surface is produced on both the valve seat and the valve, then wipe off the used compound, and repeat the process with fine compound. When a smooth unbroken ring of light grey matt finish is produced on both the valve and seat, the grinding operation is complete. *Do not* grind-in the valves any further than absolutely necessary, or the seat will be prematurely sunk into the cylinder head.



9.1 Removing the tappet side covers

**24** When all the valves have been ground-in, carefully wash off *all* traces of grinding compound using paraffin or a suitable solvent, before reassembling the cylinder head.

#### Valve components

**25** Examine the valve springs for signs of damage and discoloration. Measure their free length and compare the dimension with the figures given in the *Specifications* (**see illustration**).

**26** Stand each spring on a flat surface, and check it for squareness. If any of the springs are damaged, distorted or shorter than the specified length, obtain a complete new set of springs. It is normal to renew the valve springs as a matter of course if a major overhaul is being carried out.

**27** Renew the valve stem oil seals regardless of their apparent condition.

#### Reassembly

**28** Lubricate the stems of the valves, and insert the valves into their original locations. If new valves are being fitted, insert them into the locations to which they have been ground.

**29** As each valve is inserted, slip the oil seal into place just under the bottom of the collet groove. A much larger oil seal is used on the 1275 cc engines. This should be fitted over the top of the valve guide.

**30** Refit the valve spring(s), valve guide shield (early models) and the spring retainer.

**31** Compress the valve spring, and locate the split collets in the recess in the valve stem. Release the compressor, then repeat the procedure on the remaining valves.



*Use a little dab of grease to hold the collets in position on the valve stem while the spring compressor is released.*

**32** With all the valves installed, place the cylinder head face down on blocks on the bench and, using a hammer and interposed block of wood, tap the end of each valve stem to settle the components.

**33** The cylinder head can then be refitted as described in Part A of this Chapter.



9.2 Removing the cam followers

## 9 Camshaft and tappets - removal, inspection and refitting



**Note:** *The camshaft can only be removed with the engine out of the car and on the bench. With the cylinder head, timing cover, gears and chain, fuel pump and distributor drivegear removed, proceed as follows.*

#### Removal

**1** On 848, 998 and 1098 cc engines, undo and remove the bolt securing each tappet block side cover to the rear of the cylinder block and lift off the covers (**see illustration**).

**2** Lift out each tappet from its location in the cylinder block and ensure that they are kept in the correct sequence in which they were removed (**see illustration**). **Note:** *On 1275 cc engines, tappet block side covers are not fitted and the tappets can only be removed after removing the camshaft.*

**3** Undo and remove the three bolts and spring washers securing the camshaft locating plate to the cylinder block. Lift off the plate (**see illustration**).

**4** On 848, 998 and 1098 cc engines, carefully withdraw the camshaft from the cylinder block, taking care not to damage the camshaft bearings with the cam lobes as it is withdrawn.

**5** On 1275 cc engines position the engine on its side to prevent the tappets falling out, then slide out the camshaft. Recover the oil pump drive coupling from the end of the camshaft after removal. Now lift out each tappet, from inside the crankcase, keeping them in the correct sequence in which they were removed.

**6** On all engines, if further dismantling is to be carried out, undo the bolts still remaining and lift off the engine front plate. Recover the gasket and clean the mating surfaces of the front plate and cylinder block.

#### Inspection

##### Camshaft and camshaft bearings

**7** Carefully examine the camshaft bearings for wear. **Note:** *On 848 cc engines, only the front camshaft bearing is renewable.* If the bearings are obviously worn or pitted or the



9.3 Undo the camshaft locating plate bolts and lift off the plate



metal underlay is showing through, then they must be renewed (where applicable). This operation must be entrusted to a Rover dealer or engine reconditioning specialist as it demands the use of specialised equipment. The bearings are removed with a special drift, after which new bearings are pressed in, care being taken to ensure that the oil holes in the bearings line up with those in the block. With a special tool the bearings are then reamed in position.

**8** The camshaft itself should show no signs of wear, but if very slight scoring on the cam lobes is noticed, the score marks can be removed by very gentle rubbing down with very fine emery cloth. The greatest care should be taken to keep the cam profiles smooth.

### Tappets

**9** Examine the bearing surface of the tappets which contact the camshaft lobes. Any indentation in this surface or any cracks indicate serious wear and the tappets should be renewed. Thoroughly clean them out, removing all traces of sludge. It is most unlikely that the sides of the tappets will prove worn, but, if they are a very loose fit in their bores and can readily be rocked, they should be renewed. It is very unusual to find any wear in the tappets, and any wear present is likely to occur only at very high mileage.

### Refitting

**10** On 1275 cc engines, generously lubricate the tappets internally and externally, and insert them in the bores from which they were removed.

**11** Wipe the camshaft bearing journals clean and lubricate them generously with engine oil.

**12** Insert the camshaft into the cylinder block, taking care not to damage the camshaft bearings with the sharp edges of the cam lobes.

**13** Push the camshaft back as far as it will go

and, if the oil pump is in position, ensure that the camshaft flange has mated with the pump drive.

**14** Place a new gasket in position and refit the front plate (if previously removed).

**15** Now refit the camshaft locating plate and tighten the three retaining bolts. Temporarily refit the camshaft sprocket, then check the camshaft endfloat, referring to the figures given in the *Specifications*.

**16** Refit the remaining front plate bolts located inside the timing cover profile.

**17** On 848, 998 and 1098 cc engines, refit the tappet block side covers using new gaskets and secure with the retaining bolts.

### 10 Oil pump - removal, inspection and refitting



#### Removal

**Note:** Prior to removing the pump, it will be necessary to remove the flywheel and flywheel housing, or torque converter and housing. The oil pump engages directly via a lip and slot and splined drive with the rear of the camshaft.

**1** Bend back the locking tabs on the securing bolts which hold the pump to the block.

**2** Unscrew and remove the bolts and lock tabs, then lift off the oil pump assembly.

#### Inspection

**Note:** Three types of oil pump have been fitted during the course of production; these are the Burman, Hobourn Eaton, and the Concentric (Engineering) pumps. The Burman and Hobourn Eaton pumps may be dismantled for inspection as described below; however the Concentric (Engineering) pump is a sealed unit which cannot be dismantled, and if suspect should be exchanged for a new unit. It is quite likely that after high mileage the rotor, (or vanes), shaft, and internal body of

the pump will be quite badly scored, requiring renewal of the pump. This is mainly due to the engine and transmission sharing the same lubricating oil, making thorough filtration of minute metallic particles impossible. It is therefore recommended that a very careful inspection of the pump be carried out and, if at all suspect, the pump renewed.

**3** To dismantle either the Burman or Hobourn Eaton type of pump, undo and remove the securing screw on the rear face and lift off the cover, rotor and shaft.

**4** Examine the rotor and shaft lobes (or vanes on the Burman pump) for scoring or wear ridges. Also check the inner circumference of the pump body. Renew the complete pump if wear is apparent.

**5** If the pump is in a satisfactory condition, measure the clearances between the shaft lobes and the side of the pump body (**see illustrations**). If the clearances are outside the limits given in the *Specifications* the pump must be renewed.

**6** Reassembly of the pump is the reverse sequence to dismantling. Fill the assembled pump with clean engine oil before refitting to the engine.

#### Refitting

**7** Ensure that the pump and cylinder block mating faces are clean then place a new gasket in position on the rear face of the block.

**8** Check that the pump is filled with clean engine oil and then position it over the gasket, engaging the drive slot or coupling with the rear of the camshaft.

**9** Rotate the pump body until the offset holes in the pump, gasket and cylinder block are all in line, then refit the retaining bolts and new locktabs.

**10** Tighten the bolts to the specified torque and bend over the locktabs.



10.5a Measuring the oil pump rotor lobe clearance . . .

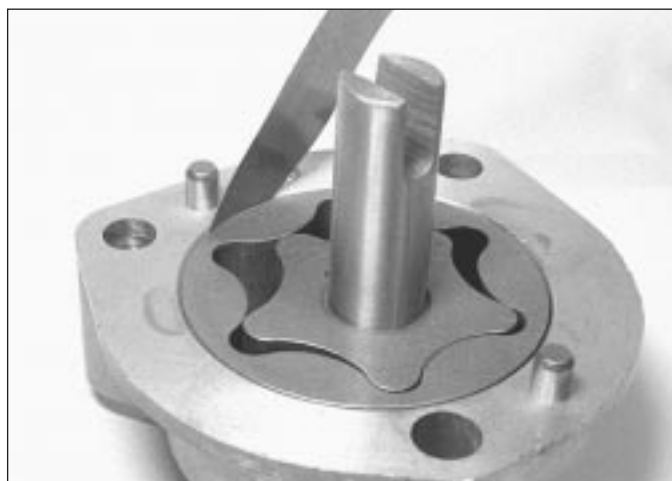

10.5b . . . and rotor-to-body clearance

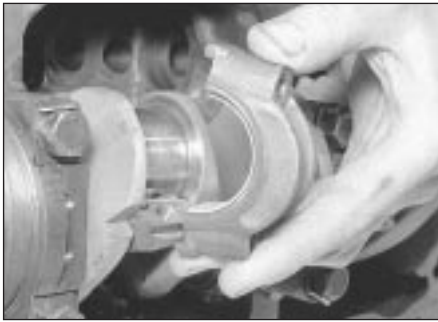

11.3 Removing a connecting rod big-end cap

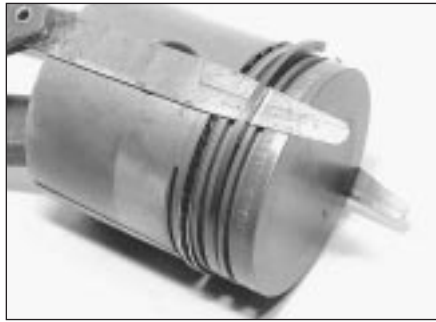

11.8 Using feeler blades to aid removal of the piston rings



11.16 Measuring the piston diameter

## 11 Piston/connecting rod - removal, inspection, separation and reconnection



### Removal

**1** With the engine separated from the transmission and the cylinder head removed, the piston/connecting rod assemblies can be removed as follows.

**2** Knock back the locking tabs on the big-end bearing cap retaining bolts, using a small chisel and remove the bolts and locking tabs. The 1275 cc engine does not have locking tabs and the big-end caps are retained by bolts and special multi-sided nuts.

**3** Remove the big-end caps one at a time, taking care to keep them in the right order and the correct way round (**see illustration**). Also ensure that the shell bearings are kept with their correct connecting rods and caps unless they are to be renewed. Normally, the numbers 1 to 4 are stamped on adjacent sides of the big-end caps and connecting rods, indicating which cap fits on which rod and which way round that cap fits. If no numbers or lines can be found then, with a sharp screwdriver, scratch mating marks across the joint from the rod to the cap. One line for connecting rod No 1, two for connecting rod No 2, and so on. This will ensure that there is no confusion later, as it is essential that the caps go back in the correct position on the connecting rods from which they were removed.

**4** If the big-end caps are difficult to remove they may be gently tapped with a soft mallet.

**5** To remove the shell bearings, press the bearing opposite the groove in both the connecting rod and the connecting rod caps, and the bearings will slide out easily.

**6** Withdraw the pistons and connecting rods upwards and ensure that they are kept in the correct order for refitting in the same bore. Refit the connecting rod caps and bearings to the rods if the bearings do not require renewal, to minimise the risk of getting the caps and rods muddled.

### Inspection

**7** Before the inspection process can begin, the piston/connecting rod assemblies must

be cleaned, and the original piston rings removed from the pistons.

**8** Carefully expand the old rings over the top of the pistons. The use of two or three old feeler blades will be helpful in preventing the rings dropping into empty grooves (**see illustration**). Be careful not to scratch the piston with the ends of the ring. The rings are brittle, and will snap if they are spread too far. They are also very sharp - protect your hands and fingers. Always remove the rings from the top of the piston. Keep each set of rings with its piston if the old rings are to be re-used.

**9** Scrape away all traces of carbon from the top of the piston. A hand-held wire brush (or a piece of fine emery cloth) can be used, once the majority of the deposits have been scraped away.

**10** Remove the carbon from the ring grooves in the piston, using an old ring. Break the ring in half to do this (be careful not to cut your fingers - piston rings are sharp). Be careful to remove only the carbon deposits - do not remove any metal, and do not nick or scratch the sides of the ring grooves.

**11** Once the deposits have been removed, clean the piston/connecting rod assembly with paraffin or a suitable solvent, and dry thoroughly. Make sure that the oil return holes in the ring grooves are clear.

**12** If the pistons and cylinder bores are not damaged or worn excessively, the original pistons can be refitted. Normal piston wear shows up as even vertical wear on the piston thrust surfaces, and slight looseness of the top ring in its groove. New piston rings should always be used when the engine is reassembled.

**13** Carefully inspect each piston for cracks around the skirt, around the gudgeon pin holes, and at the piston ring "lands" (between the ring grooves).

**14** Look for scoring and scuffing on the piston skirt, holes in the piston crown, and burned areas at the edge of the crown. If the skirt is scored or scuffed, the engine may have been suffering from overheating, and/or abnormal combustion which caused excessively high operating temperatures. The cooling and lubrication systems should be checked thoroughly. Scorch marks on the sides of the pistons show that blow-by has occurred. A

hole in the piston crown, or burned areas at the edge of the piston crown, indicates that abnormal combustion (pre-ignition, knocking, or detonation) has been occurring. If any of the above problems exist, the causes must be investigated and corrected, or the damage will occur again. The causes may include incorrect ignition timing, or a carburettor or fuel injection system fault.

**15** Corrosion of the piston, in the form of pitting, indicates that coolant has been leaking into the combustion chamber and/or the crankcase. Again, the cause must be corrected, or the problem may persist in the rebuilt engine.

**16** Using a micrometer, measure the diameter of all four pistons at a point 10 mm from the bottom of the skirt, at right angles to the gudgeon pin axis (**see illustration**). Record the measurements and use them to check the piston-to-bore clearance when the cylinder bores are measured later in this Chapter.

**17** Hold a new piston ring in the appropriate groove and measure the ring-to-groove clearance using a feeler blade (**see illustration**). Note that the rings are of different types, so use the correct ring for the groove. Compare the measurements with those listed in the *Specifications*; if the clearances are outside the tolerance range, then the pistons must be renewed.

**18** When new pistons are to be fitted, take great care to be sure to fit the exact size best suited to the particular bore of your engine. Rover go one stage further than merely specifying one size piston for all standard



11.17 Measuring the piston ring-to-groove clearance



**11.19 Identification markings on the piston crown**

bores. Because of very slight differences in cylinder machining during production, it is necessary to select just the right piston for the bore. A range of different sizes are available either from the piston manufacturer or from a Rover dealer.

**19** Examination of the cylinder block face will show, adjacent to each bore, a small diamond-shaped box with a number stamped in the metal. Careful examination of the piston crown will show a matching diamond and number (**see illustration**). These are the standard piston sizes and will be the same for all bores. If the standard pistons are to be refitted or standard low compression pistons changed to standard high compression pistons, then it is essential that only pistons with the same number in the diamond are used. With oversize pistons fitted after a rebore, the amount of oversize is stamped in an ellipse on the piston crown.

**20** Examine each connecting rod carefully for signs of damage, such as cracks around the big-end and small-end bearings. Check that the rod is not visibly bent or distorted. Damage is highly unlikely, unless the engine has been seized or badly overheated. Detailed checking of the connecting rod assembly can only be carried out by a Rover dealer or engine repair specialist with the necessary equipment.

### Separation

**21** Three different methods of gudgeon pin retention are employed, depending on the type and cubic capacity of the engine.

**22** On the 848 cc engines the gudgeon pin is clamped firmly in place by a pinch-bolt located in the end of the connecting rod (**see illustration**). To remove the piston from the connecting rod it is merely necessary to undo and remove the pinch-bolt and slide out the gudgeon pin. If it shows reluctance to move, do not force it as this may damage the piston. Immerse the piston in boiling water for a few minutes; the expansion of the aluminium should allow the pin to slide out easily.

**23** On early 998 cc and all 1098 cc engines, fully floating gudgeon pins are used, these being retained in position by a circlip at each end of the gudgeon pin bore in the piston. To remove the gudgeon pin and piston, withdraw the circlip from one end and push the pin out,

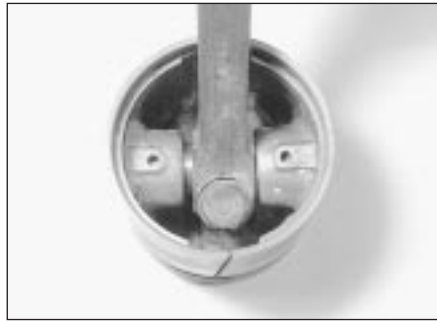

**11.22 Gudgeon pin clamped in place by a pinch-bolt (848 cc)**

immersing it in boiling water if it appears reluctant to move.

**24** On later 998 cc and all 1275 cc engines the gudgeon pin is firmly held in the small-end of the connecting rod by an interference fit. Removal of the gudgeon pin calls for the use of special tools and a good deal of experience to use them correctly. Therefore, piston and/or connecting rod renewal should be entrusted to a Rover dealer or engine repair specialist, who will have the necessary tooling to remove and install the gudgeon pins.

**25** On early 998 cc and all 1098 cc engines, check the fit of the gudgeon pin in the connecting rod bush and in the piston. If there is perceptible play, a new bush or an oversize gudgeon pin must be fitted. Consult a Rover dealer or engine reconditioning specialist.

**26** Examine all components and obtain any new parts required. If new pistons are purchased, they will be supplied complete with gudgeon pins and, where applicable, circlips. Circlips can also be purchased separately.

### Reconnection

**27** If the original pistons are being used, then they must be mated to the original connecting rod with the original gudgeon pin. If new pistons and gudgeon pins are being fitted, it does not matter which connecting rod they are used with.

**28** The gudgeon pin may be a very tight fit in the piston when cold (particularly on pistons which have a small-end clamp bolt) but, because aluminium has a greater coefficient of expansion than steel, this fit will be much easier if the piston is heated in boiling water.

**29** Lay the correct piston adjacent to its connecting rod and remember that the original rod and piston must go back into the original bore. If new pistons are being used, it is only necessary to ensure that the right connecting rod is placed in each bore.

### Gudgeon pins retained by clamp bolts

**30** Locate the small-end of the connecting rod in the piston with the marking "FRONT" on the piston crown towards the front of the engine and the hole for the gudgeon pin bolt in the connecting rod towards the camshaft.

**31** Note the indentation in the centre of the gudgeon pin, and insert the pin in the

connecting rod, so that the indentation lines up with the clamp bolt hole in such a way that the bolt will pass through without touching the gudgeon pin.

**32** For the gudgeon pin to fit correctly, it should slide in three quarters of its travel quite freely and for the remaining quarter have to be tapped in with a plastic or wooden headed hammer. If the piston is heated in water then the pin will slide in the remaining quarter easily.

**33** Fit a new spring washer under the head of the connecting rod bolt and secure it into position to the specified torque. Repeat this procedure for the remaining pistons and connecting rods.

### Fully floating gudgeon pins

**34** Fit a gudgeon pin circlip in position at one end of the gudgeon pin hole in the piston.

**35** Locate the connecting rod in the piston with the marking "FRONT" on the piston crown towards the front of the engine, and the connecting rod big-end caps towards the camshaft side of the engine.

**36** Slide the gudgeon pin in through the hole in the piston and through the connecting rod small-end until it rests against the previously fitted circlip. Note that the pin should be a push fit.

**37** Fit the second circlip in position. Repeat this procedure for the remaining pistons and connecting rods.

### Interference fit gudgeon pins

**38** As stated previously, removal and refitting of the gudgeon pin on these engines is a delicate operation requiring the use of special tools. This task must be entrusted to a Rover dealer or engine repair specialist.

## 12 Crankshaft - removal and inspection



### Removal

**1** With reference to Part A of this Chapter, and earlier Sections of this Part as applicable, carry out the following:

- a) *Separate the engine from the transmission.*
- b) *Remove the cylinder head.*
- c) *Remove the piston/connecting rod assemblies.*
- d) *Remove the timing cover, chain, tensioner and sprockets.*
- e) *Remove the camshaft locating plate and engine front plate.*

**Note:** *If no work is to be done on the pistons and connecting rods, then removal of the cylinder head and pistons will not be necessary. Instead, after disconnecting the connecting rods from the crankshaft, the pistons need only be pushed far enough up the bores so that they are positioned clear of the crankpins.*



**2** Before removing the crankshaft it is advisable to check the endfloat using a dial gauge in contact with the end of the crankshaft. Push the crankshaft fully one way, and then zero the gauge. Push the crankshaft fully the other way, and check the endfloat. The result can be compared with the specified amount, and will give an indication as to whether new thrustwashers are required.

**3** If a dial gauge is not available, feeler blades can be used. First push the crankshaft fully towards the flywheel end of the engine, then use feeler blades to measure the gap between the web of the crankpin and the thrustwasher (see illustration).

**4** If identification marks are not present on the main bearing caps, mark them suitably so that they may be refitted in their original positions and the correct way round.

**5** Release the locktabs from the six bolts which hold the three main bearing caps in place. Note that locktabs are not used on 1275 cc engines.

**6** Unscrew the bolts and remove them together with the locktabs.

**7** Remove the main bearing caps and the bottom half of each bearing shell, taking care to keep the bearing shells in the right caps.

**8** When removing the centre bearing cap, note the bottom semi-circular halves of the thrustwashers - one half lying on each side of the main bearing. Lay them with the centre bearing along the correct side (see illustration).

**9** Slightly rotate the crankshaft to free the upper halves of the bearing shells and thrustwashers, which should now be extracted and placed over the correct bearing cap.

**10** Remove the crankshaft by lifting it away from the crankcase (see illustration).

### Inspection

**11** Clean the crankshaft using paraffin or a suitable solvent, and dry it, preferably with compressed air if available. Be sure to clean the oil holes with a pipe cleaner or similar probe, to ensure that they are not obstructed.



**Warning: Wear eye protection when using compressed air!**

**12** Check the main and big-end bearing journals for uneven wear, scoring, pitting and cracking.

**13** Big-end bearing wear is accompanied by distinct metallic knocking when the engine is running (particularly noticeable when the engine is pulling from low speed) and some loss of oil pressure.

**14** Main bearing wear is accompanied by severe engine vibration and rumble - getting progressively worse as engine speed increases - and again by loss of oil pressure.

**15** Check the bearing journal for roughness by running a finger lightly over the bearing surface. Any roughness (which will be accompanied by obvious bearing wear)



**12.3** Checking crankshaft endfloat using feeler blades

indicates that the crankshaft requires regrounding (where possible) or renewal.

**16** If the crankshaft has been reground, check for burrs around the crankshaft oil holes (the holes are usually chamfered, so burrs should not be a problem unless regrounding has been carried out carelessly). Remove any burrs with a fine file or scraper, and thoroughly clean the oil holes as described previously.

**17** Using a micrometer, measure the diameter of the main and big-end bearing journals, and compare the results with the *Specifications* (see illustration). By measuring the diameter at a number of points around each journal's circumference, you will be able to determine whether or not the journal is out-of-round. Take the measurement at each end of the journal, near the webs, to determine if the journal is tapered. No actual figures are quoted by the manufacturer for crankshaft journal ovality or taper but a figure of 0.025 mm should be considered the maximum acceptable for an engine of this type. If in doubt, seek the advice of a Rover dealer or engine specialist.

**18** Check the oil seal contact surfaces at each end of the crankshaft for wear and damage. If the seal has worn a deep groove in the surface of the crankshaft, consult an engine overhaul specialist; repair may be possible, but otherwise a new crankshaft will be required.

**19** If the crankshaft journals have not been reground to their minimum regrind diameter, it may be possible to have the crankshaft reconditioned, and to fit oversize bearing



**12.10** Carefully lift out the crankshaft



**12.8** Main bearing cap with thrustwashers in position

shells (see Section 14). If the crankshaft has worn beyond the specified limits, it will have to be renewed. Consult your Rover dealer or engine specialist as to the best course of action.

## 13 Cylinder block/crankcase - cleaning and inspection



### Cleaning

**1** Remove all external components and electrical switches/sensors from the block.

**2** Scrape all traces of gasket from the cylinder block/crankcase, taking care not to damage the gasket/sealing surfaces.

**3** Remove all oil gallery plugs (where fitted). The plugs are usually very tight - they may have to be drilled out, and the holes re-tapped. Use new plugs when the engine is reassembled.

**4** If the block is extremely dirty, it should be steam-cleaned.

**5** After the block is returned, clean all oil holes and oil galleries one more time. Flush all internal passages with warm water until the water runs clear. Dry thoroughly, and apply a light film of oil to all mating surfaces, to prevent rusting., also oil the cylinder bores. If you have access to compressed air, use it to speed up the drying process, and to blow out all the oil holes and galleries.



**Warning: Wear eye protection when using compressed air!**



**12.17** Use a micrometer to measure the crankshaft bearing journal diameters





13.7 Using a tap to restore cylinder block threads



13.12 Using a bore gauge to check for cylinder bore wear

6 If the cylinder block is not very dirty, you can do an adequate cleaning job with hot (as hot as you can stand!), soapy water and a stiff brush. Take plenty of time, and do a thorough job. Regardless of the cleaning method used, be sure to clean all oil holes and galleries very thoroughly, and to dry all components well. Protect the cylinder bores as described above, to prevent rusting.

7 All threaded holes must be clean, to ensure accurate torque readings during reassembly. To clean the threads, run the correct-size tap into each of the holes to remove rust, corrosion, thread sealant or sludge, and to restore damaged threads (see illustration). If possible, use compressed air to clear the holes of debris produced by this operation.

8 Apply suitable sealant to the new oil gallery plugs, and insert them into the holes in the block. Tighten them securely.

9 If the engine is not going to be reassembled right away, cover it with a large plastic bag to keep it clean; protect all mating surfaces and the cylinder bores as described above, to prevent rusting.

### Inspection

10 Visually check the castings for cracks and corrosion. Look for stripped threads in the threaded holes. If there has been any history of internal water leakage, it may be worthwhile having an engine overhaul specialist check the cylinder block/crankcase with special equipment. If defects are found, have them repaired if possible, or renew the assembly.

11 Check each cylinder bore for scuffing and scoring. Check for signs of a wear ridge at the top of the cylinder, indicating that the bore is excessively worn.

12 If the necessary measuring equipment is available, measure the bore diameter of each cylinder at the top (just under the wear ridge), centre, and bottom of the cylinder bore, parallel to the crankshaft axis (see illustration).

13 Next, measure the bore diameter at the same three locations, at right-angles to the crankshaft axis. As no tolerance figures are actually stated by Rover, if there is any doubt about the condition of the cylinder bores, seek the advice of a Rover dealer or suitable engine reconditioning specialist.

14 Having measured the cylinder bores, subtract the piston diameters measured previously to obtain the piston-to-bore clearance for each cylinder. If the clearances are outside the tolerance range then, assuming that the cylinder bores are satisfactory, it will be necessary to fit new pistons of the correct size. If this is the case, the bores should be honed, to allow the new rings to bed in correctly and provide the best possible seal. Honing is an operation that will be carried out for you by an engine reconditioning specialist.

15 If the cylinder bores are not in perfect condition, and providing they have not already been rebored to their maximum oversize limit, it should be possible to rectify any problems found by having the cylinder bores rebored and to fit matching oversize pistons.

16 After all machining operations are completed, the entire block/crankcase must be washed very thoroughly with warm soapy water to remove all traces of abrasive grit produced during the machining operations. When the cylinder block/crankcase is completely clean, rinse it thoroughly and dry it, then lightly oil all exposed machined surfaces, to prevent rusting.

### 14 Main and big-end bearings - inspection and selection



### Inspection

1 Even though the main and big-end bearing shells should be renewed during the engine overhaul, the old shells should be retained for close examination, as they may reveal valuable information about the condition of the engine.

2 Bearing failure occurs because of lack of lubrication, the presence of dirt or other foreign particles, overloading the engine, and corrosion (see illustration). Regardless of the cause of bearing failure, the cause must be corrected (where applicable) before the engine is reassembled, to prevent it from happening again.

3 When examining the bearing shells, remove them from the cylinder block/crankcase and main bearing caps, and from the connecting rods and the big-end bearing caps, then lay them out on a clean surface in the same general position as their location in the engine. This will enable you to match any bearing problems with the corresponding crankshaft journal. Do not touch any shell's

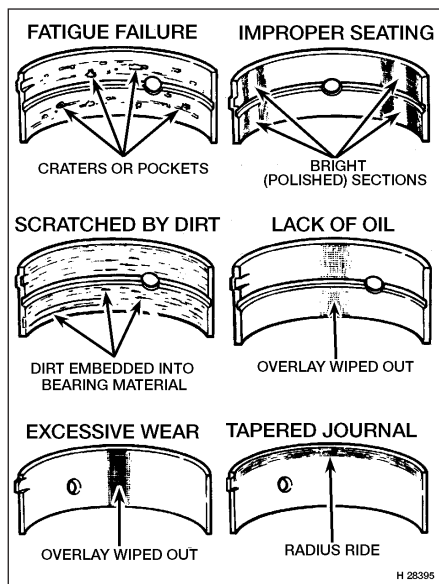

14.2 Typical bearing failures

bearing surface with your fingers while checking it, or the delicate surface may be scratched.

**4** Dirt or other foreign matter gets into the engine in a variety of ways. It may be left in the engine during assembly, or it may pass through filters or the crankcase ventilation system. It may get into the oil, and from there into the bearings. Metal chips from machining operations and normal engine wear are often present. Abrasives are sometimes left in engine components after reconditioning, especially when parts are not thoroughly cleaned using the proper cleaning methods. Whatever the source, these foreign objects often end up embedded in the soft bearing material, and are easily recognised. Large particles will not embed in the material, and will score or gouge the shell and journal. The best prevention for this cause of bearing failure is to clean all parts thoroughly, and to keep everything spotlessly-clean during engine assembly. Frequent and regular engine oil and filter changes are also recommended.

**5** Lack of lubrication (or lubrication breakdown) has a number of inter-related causes. Excessive heat (which thins the oil), overloading (which squeezes the oil from the bearing face) and oil leakage (from excessive bearing clearances, worn oil pump or high engine speeds) all contribute to lubrication breakdown. Blocked oil passages, which usually are the result of misaligned oil holes in a bearing shell, will also starve a bearing of oil, and destroy it. When lack of lubrication is the cause of bearing failure, the bearing material is wiped or extruded from the shell's steel backing. Temperatures may increase to the point where the steel backing turns blue from overheating.

**6** Driving habits can have a definite effect on bearing life. Full-throttle, low-speed operation (labouring the engine) puts very high loads on bearings, which tends to squeeze out the oil film. These loads cause the shells to flex, which produces fine cracks in the bearing face (fatigue failure). Eventually, the bearing material will loosen in pieces, and tear away from the steel backing.

**7** Short-distance driving leads to corrosion of bearings, because insufficient engine heat is produced to drive off condensed water and corrosive gases. These products collect in the engine oil, forming acid and sludge. As the oil is carried to the engine bearings, the acid attacks and corrodes the bearing material.

**8** Incorrect shell refitting during engine assembly will lead to bearing failure as well. Tight-fitting shells leave insufficient bearing running clearance, and will result in oil starvation. Dirt or foreign particles trapped behind a bearing shell result in high spots on the bearing, which lead to failure.

**9** Do not touch any shell's bearing surface with your fingers during reassembly; there is a risk of scratching the delicate surface, or of depositing particles of dirt on it.

### Selection - main and big-end bearings

**10** Main and big-end bearings for the majority of the engines described in this Chapter are available in one standard size and, on earlier engines, in a range of undersizes to suit reground crankshafts.

**11** Selective standard size main bearings are fitted to later 998 cc and 1275 cc engines. Red (R), Green (G) or Yellow (Y) codes are used to identify the bearings, and the colours or "RGY" stamp will be found on the main bearing caps and the corresponding web of the crankshaft. The bearing shells are also identified in the same way. Undersize main and big-end bearings are no longer available from Rover dealers for these engines.

**12** The relevant set of bearing shells required can be obtained by measuring the diameter of the crankshaft main bearing journals (see Section 12). This will show if the crankshaft is original or whether its journals have been reground, identifying if either standard or oversize bearing shells are required.

**13** If access to the necessary measuring equipment cannot be gained, the size of the bearing shells can be identified by the markings stamped on the rear of each shell. Details of these markings should be supplied to your Rover dealer who will then be able to identify the size of shell fitted.

**14** Whether the original shells or new shells are being fitted, it is recommended that the running clearance is checked as described in Section 17 prior to installation.

### 15 Engine overhaul - reassembly sequence

**1** Before reassembly begins, ensure that all new parts have been obtained, and that all necessary tools are available. Read through the entire procedure to familiarise yourself with the work involved, and to ensure that all items necessary for reassembly of the engine are at hand.

**2** In order to save time and avoid problems, engine reassembly can be carried out in the following order:



16.3 Piston ring identification markings

- a) Crankshaft (Section 17).
- b) Piston rings (Section 16)
- c) Piston/connecting rod assemblies (Section 18).
- d) Oil pump (Section 10).
- e) Oil filter housing and delivery pipe (Part A of this Chapter).
- f) Oil pressure relief valve (Part A of this Chapter).
- g) Camshaft and tappets (Section 9).
- h) Cylinder head (Part A of this Chapter).
- i) Timing chain, sprockets and tensioner (Part A of this Chapter).
- j) Distributor driveshaft (Part A of this Chapter).
- k) Engine external components.

**3** At this stage, all engine components should be absolutely clean and dry, with all faults repaired. The components should be laid out (or in individual containers) on a completely clean work surface.

### 16 Piston rings - refitting



**1** Before fitting new piston rings, the ring end gaps must be checked as follows.

**2** Lay out the piston/connecting rod assemblies and the new piston ring sets, so that the ring sets will be matched with the same piston and cylinder during the end gap measurement and subsequent engine reassembly.

**3** Insert the top ring into the first cylinder, and push it down the bore using the top of the piston. This will ensure that the ring remains square with the cylinder walls. Position the ring near the bottom of the cylinder bore, at the lower limit of ring travel. On engines with tapered second and third compression rings, the top narrow side of the ring is marked with a "T", or the word "TOP" (see illustration).

**4** Measure the end gap using feeler blades.

**5** Repeat the procedure with the ring at the top of the cylinder bore, at the upper limit of its travel, and compare the measurements with the figures given in the *Specifications*.

**6** If the gap is too small (unlikely if genuine Rover parts are used), it must be enlarged, or the ring ends may contact each other during engine operation, causing serious damage. Ideally, new piston rings providing the correct end gap should be fitted. As a last resort, the end gap can be increased by filing the ring ends very carefully with a fine file. Mount the file in a vice equipped with soft jaws, slip the ring over the file with the ends contacting the file face, and slowly move the ring to remove material from the ends. Take care, as piston rings are sharp, and are easily broken.

**7** With new piston rings, it is unlikely that the end gap will be too large. If the gaps are too large, check that you have the correct rings for your engine and for the particular cylinder bore size.

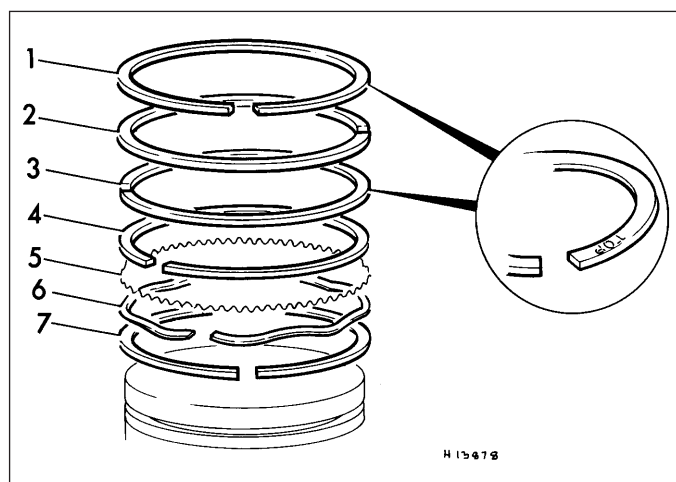

16.10a Piston ring identification - 850, 1000 and 1100 models

- |                                  |               |
|----------------------------------|---------------|
| 1 Chrome plated compression ring | 4 Top rail    |
| 2 Taper compression ring         | 5 Expander    |
| 3 Taper compression ring         | 6 Side spring |
|                                  | 7 Bottom rail |

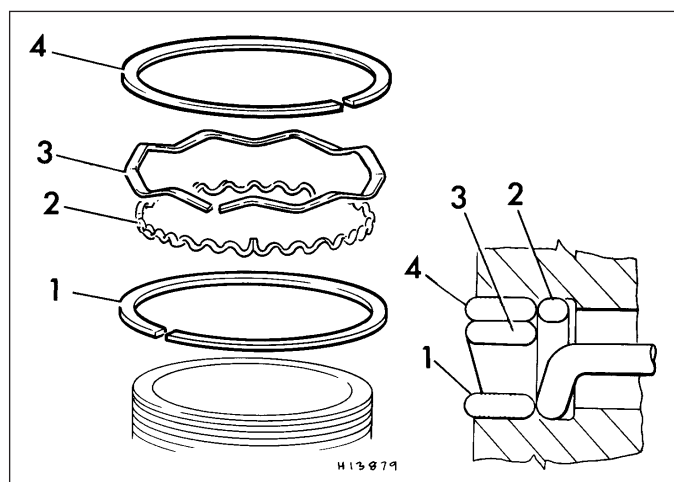

16.10b Correct assembly of oil control ring - 1275 models

- |               |                         |
|---------------|-------------------------|
| 1 Bottom rail | 3 Oil control ring rail |
| 2 Expander    | 4 Top rail              |

**8** Repeat the checking procedure for each ring in the first cylinder, and then for the rings in the remaining cylinders. Remember to keep rings, pistons and cylinders matched up.

**9** Once the ring end gaps have been checked and if necessary corrected, the rings can be fitted to the pistons.

**10** Fit the piston rings using the same technique as for removal. Fit the bottom (oil control) ring first, and work up. When fitting a three piece oil control ring, first insert the expander and position its gap in line with the centre of the gudgeon pin. Fit the scraper rings with their gaps positioned either side of the expander gap. Where the oil control scraper is of one-piece type, position its gap 180° from the expander gap. Ensure that the second and third compression rings are fitted the correct way up, with their identification mark (either a "T" or the word "TOP" stamped on the ring surface) at the top (**see illustrations**). Carefully examine all rings for this mark before fitting. Arrange the gaps of the compression rings equally around the piston. **Note:** Always follow any instructions supplied with the new piston ring sets - different manufacturers may specify different procedures. Do not mix up the top and second compression rings, as they have different cross-sections.

**2** Position the cylinder block on a clean level work surface, with the crankcase facing upwards. Unbolt the bearing caps and carefully release them from the crankcase; lay them out in order to ensure correct reassembly. If they're still in place, remove the old bearing shells from the caps and crankcase and wipe out the inner surfaces with a clean rag - they must be kept spotlessly clean.

**3** Clean the backs of the bearing shells and insert them into position in the crankcase. If the original bearing shells are being used for the check, ensure that they are refitted in their original locations. Press the shells home so that the tangs engage in the recesses provided. When fitting the rear main bearing shell, it may be found that the cylinder block oilway is offset from the corresponding hole in the bearing shell. This condition is acceptable as long as a 2.3 mm diameter steel rod can be inserted into the exposed section of the hole.

**4** Give the newly fitted bearing shells and the crankshaft journals a final clean with a rag. Check that the oil holes in the crankshaft are free from dirt, as any left here will become embedded in the new bearings when the engine is started.

**5** Carefully lay the crankshaft in the crankcase taking care not to dislodge the bearing shells.

removed, the plastic is deformed and can be measured with a special card gauge supplied with the kit. The running clearance is determined from this gauge. The procedure for using Plastigage is as follows.

**7** Cut off three lengths of Plastigage (they should be slightly shorter than the width of the main bearings) and place one length on each crankshaft journal axis (**see illustration**).

**8** Wipe the inner surface of the bearing caps and the backs of the lower bearing shells and fit the three bearing shells to their caps. Press the shells home so that the tangs engage in the recesses provided.

**9** Ensure that all six tubular locating dowels are firmly in place, one on each side of the upper halves of the three main bearings, and then fit the main bearing caps in position ensuring that they locate properly on the dowels. Tighten their retaining bolts to the specified torque. Take care not to disturb the Plastigage and **do not** rotate the crankshaft at any time during this operation.

**10** Remove the main bearing caps again taking great care not to disturb the Plastigage or rotate the crankshaft.

## 17 Crankshaft - refitting and running clearance check



**1** Crankshaft refitting is the first stage of engine reassembly following overhaul. It is assumed at this point that the cylinder block/crankcase and crankshaft have been cleaned, inspected and repaired or reconditioned as necessary.

### Running clearance check

**6** When the crankshaft and bearings are fitted, a clearance must exist between them to allow lubricant to circulate. This clearance is impossible to check using feeler blades, so Plastigage is used. This consists of a fine thread of perfectly round plastic which is compressed between the bearing shell and the journal when the bearing caps are tightened up. When the cap and shell is



17.7 Plastigage in place on main bearing journal





17.11 Measuring the width of the deformed Plastigage using the card gauge supplied



17.19 Refitting the crankshaft thrustwasher upper halves

11 Compare the width of the crushed Plastigage on each journal to the scale printed on the Plastigage envelope to obtain the main bearing running clearance (see illustration). Use the correct scale as both imperial and metric are printed. Compare the clearance measured with the running clearance dimension given in the *Specifications*.

12 If the clearance is significantly different from that expected, the bearing shells may be the wrong size (or excessively worn if the original shells are being re-used). Before deciding that the crankshaft is worn, make sure that no dirt or oil was trapped between the bearing shells and the caps or block when the clearance was measured. If the Plastigage was wider at one end than at the other, the crankshaft journal may be tapered.

13 Before condemning the components concerned, seek the advice of your Rover dealer or suitable engine repair specialist. They will also be able to inform as to the best course of action and whether it is possible to have the crankshaft journals reground or whether renewal will be necessary.

14 Where necessary, obtain the correct size of bearing shell and repeat the running clearance checking procedure as described above.

15 On completion, carefully scrape away all traces of the Plastigage material from the crankshaft and bearing shells using a fingernail or other object which is unlikely to score the bearing surfaces.



17.22 Tighten the main bearing cap bolts to the specified torque

### Crankshaft - final refitting

16 Lift the crankshaft out of the crankcase. Wipe the surfaces of the bearings in the crankcase and the bearing caps.

17 Wipe the recesses either side of the centre main bearings which locate the upper halves of the thrustwashers.

18 Generously lubricate the crankshaft journals and the upper and lower main bearing shells with clean engine oil and carefully place the crankshaft in position.

19 Introduce the upper halves of the thrustwashers (the halves without tabs) into their grooves on each side of the centre main bearing (see illustration), rotating the crankshaft in the direction towards the main bearing tabs (so that the main bearing shells do not slide out). At the same time feed the thrustwashers into their locations with their oil grooves facing outwards away from the bearing.

20 Ensure that all six tubular locating dowels are still firmly in place, one on each side of the upper halves of the three main bearings, and then fit the main bearing caps in position ensuring that they locate properly on the dowels. The mating surfaces must be spotlessly clean or the caps will not seat properly.

21 When refitting the centre main bearing cap, ensure that the thrustwashers, generously lubricated, are fitted with their oil grooves facing outwards, and the locating tab of each washer is in the slot in the bearing cap.

22 Refit the one-piece locking tabs over the main bearing caps (where applicable) and refit the main bearing cap bolts, screwing them up finger-tight initially, then finally tightening to the torque setting given in the *Specifications* (see illustration).

23 Test the crankshaft for freedom of rotation. Should it be very stiff to turn or possess high spots, re-check the running clearances as described above.

24 Carry out a check of the crankshaft endfloat as described in Section 12. If the thrust surfaces of the crankshaft have been checked and new thrustwashers have been fitted, then the endfloat should be within specification.

25 When all is satisfactory, secure the main bearing bolts by knocking up the locking tabs (where applicable) with a small chisel.

### 18 Piston/connecting rod assemblies - refitting and big-end bearing clearance check



**Note:** At this point it is assumed that the crankshaft has been refitted to the engine as described in Section 17.

#### Big-end bearing running clearance check

1 Clean the backs of the bearing shells, and the bearing locations in both the connecting rod and bearing cap.

2 Press the bearing shells into their locations, ensuring that the tab on each shell engages in the notch in the connecting rod and cap. If the original bearing shells are being used for the check, ensure that they are refitted in their original locations.

3 As with the main bearings (Section 17), a running clearance must exist between the big-end crankpin and its bearing shells to allow oil to circulate. There are two methods of checking the running clearance as described in the following paragraphs.

4 One method is to refit the big-end bearing cap to the connecting rod, with the bearing shells in place. With the cap retaining nuts or bolts correctly tightened, use an internal micrometer or vernier caliper to measure the internal diameter of each assembled pair of bearing shells. If the diameter of each corresponding crankshaft journal is measured and then subtracted from the bearing internal diameter, the result will be the big-end bearing running clearance.

5 The second, and more accurate method is to use Plastigage (see Section 17).

6 Ensure that the bearing shells are correctly fitted. Place a strand of Plastigage on each (cleaned) crankpin journal.

7 Temporarily refit the (clean) piston/connecting rod assemblies to the crankshaft,



and refit the big-end bearing caps, using the marks made or noted on removal to ensure that they are fitted the correct way around.

**8** Tighten the bearing cap nuts or bolts to the specified torque. Take care not to disturb the Plastigage, nor rotate the connecting rod during the tightening sequence.

**9** Dismantle the assemblies without rotating the connecting rods. Use the scale printed on the Plastigage envelope to obtain the big-end bearing running clearance. Use the correct scale as both imperial and metric are printed.

**10** If the clearance is significantly different from that given in the *Specifications*, the bearing shells may be the wrong size (or excessively worn, if the original shells are being re-used). Make sure that no dirt or oil was trapped between the bearing shells and the caps or block when the clearance was measured. If the Plastigage was wider at one end than at the other, the crankshaft journal may be tapered.

**11** Before condemning the components concerned, refer to your Rover dealer or engine reconditioning specialist for their advice on the best course of action to be taken.

**12** On completion, carefully scrape away all traces of the Plastigage material from the crankshaft and bearing shells. Use your fingernail, or some other object which is unlikely to score the bearing surfaces.

### **Piston/connecting rod assemblies - final refitting**

**13** Ensure that the bearing shells are correctly fitted as described earlier. Wipe dry the shells and connecting rods with a clean cloth.

**14** Lubricate the cylinder bores, the pistons, and piston rings, then lay out each piston/connecting rod assembly in its respective position.

**15** Start with assembly No 1. Make sure that



**18.16 Refitting a piston with a piston ring clamp in position**

the piston rings are still spaced as described in Section 16, then clamp them in position with a piston ring compressor.

**16** Insert the piston/connecting rod assembly into the top of cylinder No 1. Ensure that it is the correct piston/connecting rod assembly for that particular bore, that the connecting rod is the right way round, and that the front of the piston is towards the front of the engine. Using a block of wood or hammer handle against the piston crown, tap the assembly into the cylinder until the piston crown is flush with the top of the cylinder (*see illustration*).

**17** Ensure that the bearing shell is still correctly installed. Liberally lubricate the crankpin and both bearing shells. Taking care not to mark the cylinder bores, pull the piston/connecting rod assembly down the bore and onto the crankpin. As the big-end bosses on the connecting rods are offset, it will be obvious if they have been inserted the wrong way round because they will not fit over the crankpin. The centre two rods must be fitted with their offset bosses facing away from the centre main bearing, and the connecting rods at each extremity of the engine must be fitted with their offset bosses

facing inwards (*see illustration*). Fit the big-end cap and retaining bolts with the one-piece locking tab under them (where applicable) and tighten the bolts to the specified torque. On 1275 cc engines the arrangement is slightly different, the caps being retained by nuts.

**18** Once the bearing cap retaining nuts or bolts have been correctly tightened, rotate the crankshaft. Check that it turns freely; some stiffness is to be expected if new components have been fitted, but there should be no signs of binding or tight spots.

**19** Refit the remaining three piston/connecting rod assemblies in the same way.

### **19 Engine - initial start-up after overhaul and reassembly**



**1** Refit the remainder of the engine components in the order listed in Section 15 of this Chapter, referring to Part A where necessary. Reconnect the engine to the transmission (Section 5 or 6 as applicable), then refit the power unit to the car as described in Section 3.

**2** With the engine/transmission refitted, double-check the engine oil and coolant levels. Make a final check that everything has been reconnected, and that there are no tools or rags left in the engine compartment.

**3** Remove the spark plugs. Disable the ignition system by disconnecting the ignition HT coil lead from the distributor cap, and earthing it on the cylinder block. Use a jumper lead or similar wire to make a good connection.

**4** Turn the engine on the starter until the oil pressure warning light goes out. Refit the spark plugs, and reconnect the spark plug and distributor (HT) leads, referring to Chapter 1 for further information.

**5** Start the engine, noting that this may take a little longer than usual, due to the fuel system components having been disturbed.

**6** While the engine is idling, check for fuel, water and oil leaks. Don't be alarmed if there are some odd smells and smoke from parts getting hot and burning off oil deposits.

**7** Assuming all is well, keep the engine idling until hot water is felt circulating through the top hose, then switch off the engine.

**8** Check the ignition timing and the idle speed settings (as appropriate), then switch the engine off.

**9** After a few minutes, recheck the oil and coolant levels as described in Chapter 1, and top-up as necessary.

**10** If new pistons, rings or crankshaft bearings have been fitted, the engine must be treated as new, and run-in for the first 500 miles (800 km). *Do not* operate the engine at full-throttle, or allow it to labour at low engine speeds in any gear. It is recommended that the oil and filter be changed at the end of this period.

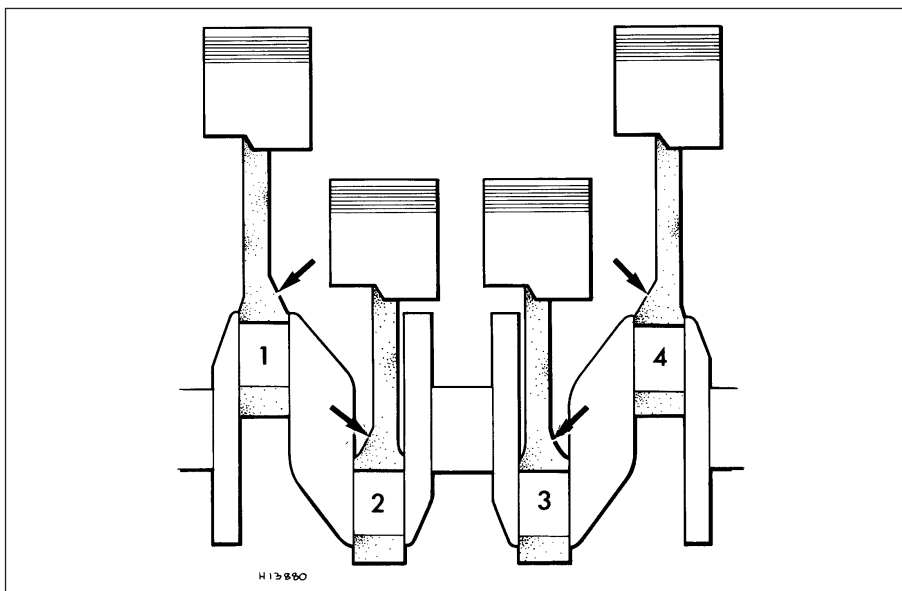

**18.17 The correct positions of the offsets on the connecting rod big-ends**





# Chapter 3

## Cooling, heating and ventilation systems

### Contents

Antifreeze - general information . . . . .	3	Fresh air vent assembly - removal and refitting . . . . .	13
Auxiliary cooling fan - general information, removal and refitting . . .	7	General information and precautions . . . . .	1
Auxiliary cooling fan thermostatic switch - removal, testing and refitting . . . . .	8	Heater assembly - dismantling and reassembly . . . . .	12
Coolant level check . . . . .	See "Weekly Checks"	Heater assembly - removal and refitting . . . . .	11
Cooling system - draining . . . . .	See Chapter 1	Heater water valve - removal and refitting . . . . .	10
Cooling system - filling . . . . .	See Chapter 1	Heater water valve control cable - removal and refitting . . . . .	9
Cooling system - flushing . . . . .	See Chapter 1	Radiator - removal and refitting . . . . .	4
Cooling system hoses - disconnection and renewal . . . . .	2	Thermostat - removal, testing and refitting . . . . .	5
Fan belt check and renewal . . . . .	See Chapter 1	Water pump - removal and refitting . . . . .	6

### Degrees of difficulty

<b>Easy</b> , suitable for novice with little experience 	<b>Fairly easy</b> , suitable for beginner with some experience 	<b>Fairly difficult</b> , suitable for competent DIY mechanic 	<b>Difficult</b> , suitable for experienced DIY mechanic 	<b>Very difficult</b> , suitable for expert DIY or professional 
---	--	--	---	--

3

### Specifications

#### General

System type . . . . .	Pressurised, water pump assisted, thermo-syphon
Radiator filler/pressure cap setting:	
Pre-1974 models . . . . .	0.91 bar
1974 models onward . . . . .	1.05 bar

#### Thermostat

Type . . . . .	Wax
Opening temperatures:	
Pre-1976 models:	
Standard . . . . .	82°C
Hot climates . . . . .	74°C
Cold climates . . . . .	88°C
1976 models onward:	
Standard . . . . .	88°C

#### Auxiliary cooling fan

Thermostatic switch settings:	
Switches on at . . . . .	98°C
Switches off at . . . . .	93°C

#### Torque wrench settings

	Nm	lbf ft
Water pump . . . . .	19 to 25	14 to 18
Thermostat housing . . . . .	8 to 12	6 to 9
Auxiliary cooling fan thermostatic switch - Cooper models . . . . .	10	7

## 1 General information and precautions

The cooling system is of the conventional pressurised, water pump-assisted thermo-siphon type comprising a radiator, water pump, thermostat and associated hoses. Radiator cooling is provided by a fan mounted on the water pump and driven by a V-belt from the crankshaft pulley. An auxiliary electric cooling fan is fitted to later 1275 cc engine models. It is located beneath the left-hand front wheel arch, and provides an additional source of cooling for the radiator in conjunction with the belt-driven fan on the water pump.

The cooling system functions by circulating cold coolant from the bottom of the radiator, up the lower radiator hose to the water pump where it is pumped around the water passages in the cylinder block.

The coolant then travels up into the cylinder head and circulates around the combustion chambers and valve seats. When the engine is at its correct operating temperature, the coolant travels out of the cylinder head, past the open thermostat, into the hose and so into the top tank of the radiator. The coolant travels down the radiator where it is rapidly cooled by the rush of cold air through the radiator core. As the radiator is mounted next to the wheel arch, the fan *pushes* cold air through the radiator matrix. The coolant, now cool, reaches the bottom of the radiator where the cycle is repeated.

When the engine is cold, the thermostat (which is simply a temperature sensitive valve), maintains the circulation of coolant in the engine by blocking the passage from the cylinder head to the radiator. The coolant is then forced to return to the cylinder block through the bypass hose. Only when the opening temperature of the thermostat has been reached, does the thermostat allow the coolant to return to the radiator.

A basic heating and ventilation system is fitted which supplies warm or cold air to either the windscreen or car interior. A two-speed blower fan is fitted to supplement the airflow as required. Fresh air ventilation is provided by controllable air vents, located below the windscreen on each side of the car. These vents are independent of the main heater/blower unit and provide ambient air when the car is moving. The volume of air supplied is dependent on road speed.

### Precautions



**Warning:** Do not attempt to remove the radiator filler cap, or to disturb any part of the cooling system, while it or the engine is hot, as there is a very great risk of scalding. If the filler cap must be removed before the engine and radiator have fully cooled down (even though this is not recommended) the pressure in the cooling system must first be released. Cover the cap with a thick

layer of cloth, to avoid scalding, and slowly unscrew the filler cap until a hissing sound can be heard. When the hissing has stopped, showing that pressure is released, slowly unscrew the filler cap further until it can be removed; if more hissing sounds are heard, wait until they have stopped before unscrewing the cap completely. At all times, keep well away from the filler opening.



**Warning:** Do not allow antifreeze to come in contact with your skin, or with the painted surfaces of the vehicle. Rinse off spills immediately with plenty of water. Never leave antifreeze lying around in an open container, or in a puddle in the driveway or on the garage floor. Children and pets are attracted by its sweet smell, but antifreeze is fatal if ingested.

## 2 Cooling system hoses - disconnection and renewal

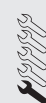

**Note:** Refer to the warnings given in Section 1 of this Chapter before proceeding. Hoses should only be disconnected once the engine has cooled sufficiently to avoid scalding.

- 1 If the checks described in Chapter 1 reveal a faulty hose, it must be renewed as follows.
- 2 First drain the cooling system (Chapter 1); if the antifreeze is not due for renewal, the drained coolant may be re-used, if it is collected in a clean container.
- 3 To disconnect the main system hoses, use a pair of pliers to release the spring clamps (or a screwdriver to slacken screw-type clamps), then move them along the hose clear of the union. Carefully work the hose off its stubs. The hoses can be removed with relative ease when new - on an older vehicle, they may have stuck.
- 4 If a hose proves to be difficult to remove, try to release it by rotating it on its unions before attempting to work it off. Gently prise the end of the hose with a blunt instrument (such as a flat-bladed screwdriver), but do not apply too much force, and take care not to damage the pipe stubs or hoses. Note in particular that the radiator hose unions are fragile; do not use excessive force when attempting to remove the hoses.



**Hint:** If all else fails, cut the hose with a sharp knife, then slit it so that it can be peeled off in two pieces. Although this may prove expensive if the hose is otherwise undamaged, it is preferable to buying a new radiator.

- 5 When refitting a hose, first slide the clamps onto the hose, then engage the hose with its unions. Work the hose into position, then check that the hose is settled correctly and is properly routed. Slide each clip along the hose until it is behind the union flared end, before tightening it securely.



**Hint:** If the hose is stiff, use a little soapy water as a lubricant, or soften the hose by soaking it in hot water. Do not use oil or grease, which may attack the rubber.

- 6 Renewal of the by-pass hose (fitted between the top of the water pump and the underside of the cylinder head) is an awkward and tedious task which often presents problems. The easiest way to refit a bypass hose is to first place both clips in position on the hose. Fit the bottom of the hose to the water pump, bend the hose in half and then place the flat faces of a knife or feeler blade over the top of the hose and outlet in the cylinder head. Push the hose into an upright position and withdraw the blade. The hose should now be in position over the outlet. Several attempts may be necessary before the hose slides properly into position.

7 Refill the system with coolant (Chapter 1).

- 8 Check carefully for leaks as soon as possible after disturbing any part of the cooling system.

## 3 Antifreeze - general information

**Note:** Refer to the warnings given in Section 1 of this Chapter before proceeding.

1 The cooling system should be filled with a water/ethylene glycol-based antifreeze solution, of a strength which will prevent freezing down to at least -25°C, or lower if the local climate requires it. Antifreeze also provides protection against corrosion, and increases the coolant boiling point. As with all mixed metal engines, the corrosion protection properties of the antifreeze are critical. Only a top quality antifreeze should be used in the system and should never be mixed with different antifreeze types.

2 The cooling system should be maintained according to the schedule described in Chapter 1. If antifreeze is used that is not to Rover's specification, old or contaminated coolant mixtures are likely to cause damage, and encourage the formation of corrosion and scale in the system.

3 Before adding antifreeze, check all hoses and hose connections, because antifreeze tends to leak through very small openings. Engines don't normally consume coolant, so if the level goes down, find the cause and correct it.

4 Ideally, at least a 30% mixture of antifreeze and clean soft water (by volume) should be used to maintain maximum protection against freezing and corrosion. Mix the required quantity in a clean container and then fill the system as described in Chapter 1, and "Weekly Checks". Save any surplus mixture for topping-up.

## 4 Radiator - removal and refitting



**Note:** Refer to the warnings given in Section 1 of this Chapter before proceeding.

**HAYNES HINT** *If leakage is the reason for wanting to remove the radiator, bear in mind that minor leaks can often be cured using a radiator sealant with the radiator in situ.*

### Removal

- 1 Drain the cooling system as described in Chapter 1.
- 2 Refer to Chapter 11 and remove the bonnet.
- 3 Slacken the two retaining clips and completely remove the radiator top hose.
- 4 If the bottom hose was not removed for draining, slacken the retaining clip, using a long thin screwdriver, and pull the hose off the radiator outlet.
- 5 Undo and remove the bolts and nuts securing the radiator upper support bracket to

the fan cowl and thermostat housing. Lift away the bracket (**see illustration**).

6 On later 1275 cc engines (except carburettor engine Cooper models) disconnect the wiring connectors at the auxiliary cooling fan thermostatic switch in the bottom corner of the radiator.

7 At the base of the radiator undo and remove either the long through-bolt or the two short bolts (depending on model) that secure the lower support bracket to the engine mounting (**see illustration**). If necessary remove the front grille panel as described in Chapter 11 to provide greater access.

### 4.5 Exploded view of radiator and attachments

- 1 Filler cap
- 2 Radiator
- 3 Drain tap adapter
- 4 Drain tap or plug
- 5 Rubber surround
- 6 Overflow pipe
- 7 Retaining clip
- 8 Cowl fixing screw
- 9 Nut
- 10 Cowl (one piece type)
- 11 Cowl (upper - two piece type)
- 12 Cowl (lower - two-piece type)
- 13 Bottom hose (non-heater type)
- 14 Bottom hose (heater type)
- 15 Hose clip
- 16 Upper mounting
- 17 Bolt
- 18 Washer
- 19 Rubber grommet
- 20 Lower mounting
- 21 Bolt
- 22 Washer
- 23 Rubber grommet
- 24 Washer
- 25 Bolt
- 26 Top hose

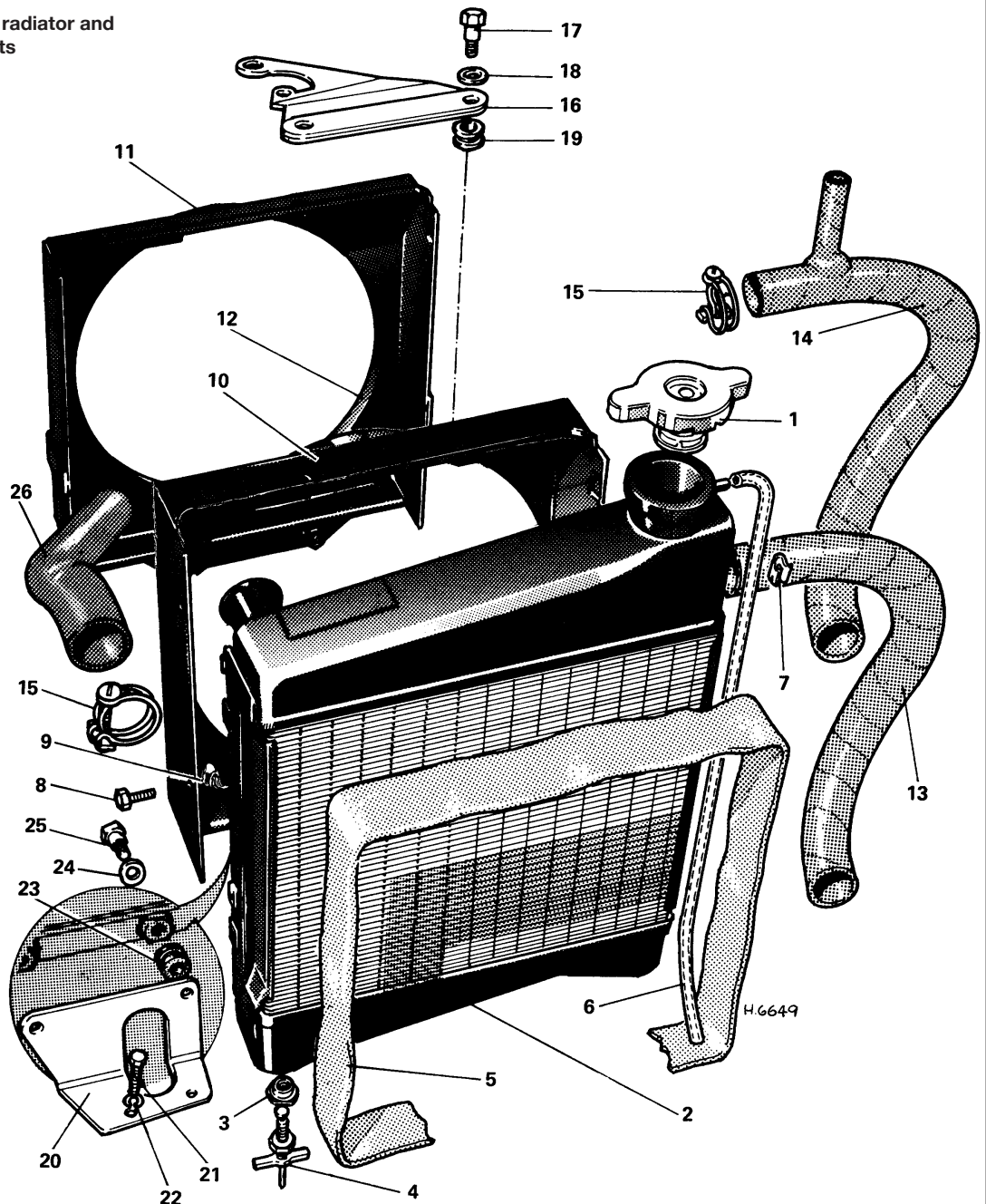





**4.7 Radiator lower support mounting bolt accessible through grille panel**

**8** Undo and remove the bolts securing the fan cowlings to the radiator, move the cowlings as far as possible toward the engine and carefully lift out the radiator. If a two piece cowling is fitted, lift off the top half.

### Refitting

**9** Refitting is the reverse sequence to removal. Apply a little rubber grease or liquid detergent to the inside diameter of the hoses, to allow them to be refitted more easily.

**10** With the radiator in position, refill the cooling system as described in Chapter 1, and refit the bonnet and (if removed) the front grille panel as described in Chapter 11.

## 5 Thermostat - removal, testing and refitting



**Note:** Refer to the warnings given in Section 1 of this Chapter before proceeding.

### Removal

**1** Partially drain the cooling system (approximately 1 litre) as described in Chapter 1.

**2** Undo the retaining bolts securing the upper radiator mounting bracket to the radiator cowl.

**3** Undo the two nuts or bolts securing the upper radiator mounting bracket to the thermostat cover, or the single nut securing the bracket to the thermostat housing body (see illustrations). Remove the bracket.

**4** Slacken the radiator top hose retaining clip and disconnect the hose from the thermostat cover. Where applicable, disconnect the heater hose from the thermostat housing body and the wiring from the thermostatic switch or vacuum hoses from the thermostatic valve in the side of the housing body. Note the correct fitted positions of the vacuum hoses before disconnection.

**5** Undo the remaining nut, or the three bolts (according to type) securing the thermostat cover, and lift off the cover and gasket. Where the cover is retained by nuts and studs, it is likely to be quite tight due to corrosion of the retaining studs. If so, apply liberal amounts of penetrating oil to the studs and allow time to

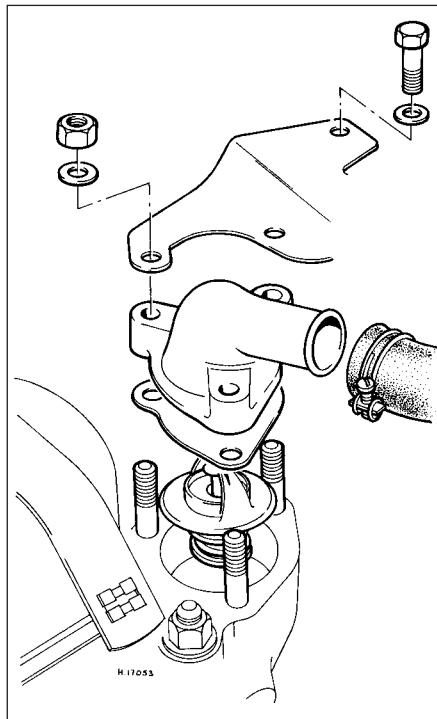

**5.3a Exploded view of the thermostat and housing components (early models)**

soak. Now very gently tap the cover from side to side, using a soft-faced mallet or block of wood. This should ease the corrosion and allow the cover to be lifted off.

**6** With the cover removed, take out the thermostat.

**7** On models with a separate thermostat housing body beneath the cover, lift off the housing body together with its lower gasket.

### Testing

**8** To test the thermostat for correct functioning, suspend it on a string in a saucepan of cold water together with a

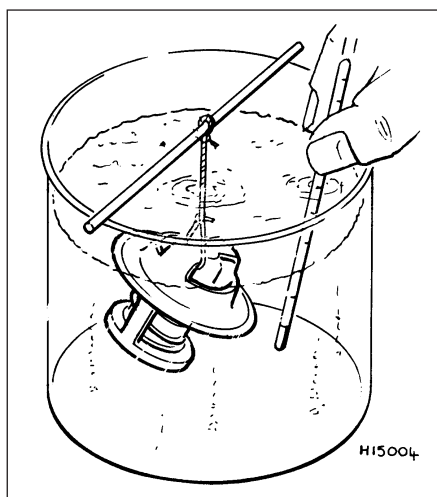

**5.8 Testing the thermostat**



**5.3b Thermostat housing and radiator upper mounting bracket (later 1275 cc models)**

thermometer (see illustration). Heat the water and note the temperature at which the thermostat begins to open. The correct opening temperatures are given in the *Specifications* at the beginning of this Chapter. Continue heating the water until the thermostat is fully open. Then let it cool down naturally.

**9** If the thermostat does not fully open in boiling water, or does not close down as the water cools, then it must be discarded and a new one fitted. Should the thermostat be stuck open when cold, this will be apparent during removal.

### Refitting

**10** Refitting is the reverse sequence to removal bearing in mind the following points:

- Clean off all traces of old gasket from the component mating faces and renew any parts which show signs of corrosion.
- Where the thermostat is located directly in the cylinder head, use a new gasket between the cylinder head and thermostat cover. On models with a separate thermostat housing body, use new gaskets on both sides of the housing body.
- Refill the cooling system as described in Chapter 1 on completion.

## 6 Water pump - removal and refitting



**Note:** Water pump failure is indicated by water leaking from the gland or front of the pump, or by rough and noisy operation. This is usually accompanied by excessive play of the pump spindle which can be checked by moving the fan blades from side to side. Water pumps are relatively inexpensive items and the simplest course of action, should the above symptoms be evident, is to fit an exchange reconditioned unit. Refer to the warnings given in Section 1 of this Chapter before proceeding.

### Removal

**Note:** If the car is fitted with exhaust emission control equipment, it will be necessary to remove the air pump and drivebelt, as described in Chapter 4C, to provide access to the water pump.

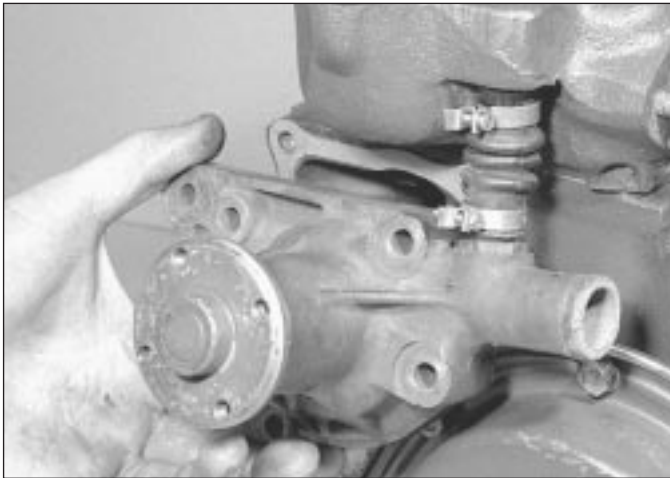

6.5 Removing the water pump (shown with engine removed)

- 1 Remove the radiator (Section 4).
- 2 Remove the fan belt as described in Chapter 1, then undo and remove the two nuts, bolts and washers securing the dynamo or alternator to the mounting bracket and water pump flange. Move the dynamo or alternator away from the engine, pivoting it on the adjusting arm bolt, and allow the unit to rest against the body front panel.
- 3 Undo and remove the bolts securing the fan and fan pulley to the water pump hub. Lift off the fan and pulley, and where fitted recover the spacer. As a guide to reassembly, make a mark to indicate the outer face of the fan as it is quite easy to refit this component the wrong way round.
- 4 Slacken the hose clips and detach the radiator bottom hose from the water pump outlet and also from the heater take-off connection, where applicable. Now slacken the clip that secures the bypass hose to the outlet on the top of the pump.
- 5 Undo and remove the four bolts securing the water pump to the cylinder block. Lift off the pump, and at the same time detach the bypass hose. Recover the water pump gasket (see illustration).
- 6 Before refitting the pump, clean off all traces of old gasket from the water pump and cylinder block mating faces, ensuring that the faces are smooth, clean and dry.

### Refitting

- 7 Refitting the water pump is the reverse sequence to removal, bearing in mind the following points:
  - a) Always use a new gasket, which should be lightly smeared on both sides with jointing compound.
  - b) The bypass hose should be renewed as a matter of course, because these hoses sometimes prove unreliable and are extremely difficult to renew when the water pump is installed.
  - c) Refit and adjust the fan belt as described in Chapter 1.
  - d) Refit the radiator as described in Section 4.

## 7 Auxiliary cooling fan - general information, removal and refitting



### General information

- 1 An auxiliary electric cooling fan is fitted to all later 1275 cc engine models. It is located beneath the left-hand front wheel arch, and provides an additional source of cooling for the radiator in conjunction with the belt-driven fan on the water pump.
- 2 The auxiliary cooling fan is switched on and off by a thermostatic switch. On carburettor engine Cooper models, the switch is screwed into the thermostat housing body on the cylinder head, whereas on all other models it is situated in the front bottom corner of the radiator.

### Removal - carburettor engine Cooper models

- 3 Chock the rear wheels then jack up the front of the car and support it on axle stands (see "Jacking and vehicle support"). Remove the left-hand front roadwheel.
- 4 Disconnect the air duct from the adapter beneath the front left-hand headlight.
- 5 Trace the fan motor wiring back to its connector, and disconnect it from the main wiring harness.
- 6 Slacken and remove the four cooling fan assembly shroud mounting nuts, and remove the assembly from underneath the wheel arch. Recover the mounting brackets, rubbers and spacers.

### Removal - all except carburettor engine Cooper models

- 7 Remove the front grille as described in Chapter 11.
- 8 Undo the three mounting bolts and remove the radiator upper mounting bracket. Loosen the lower radiator mounting bolt.



7.9 Auxiliary fan motor wiring connector (arrowed) - fuel injection models

- 9 Disconnect the fan motor wiring connector, which is situated by the side of the radiator filler cap (see illustration), and release the wiring grommet from the wing valance.
- 10 Slacken and remove the three (one lower and two upper) mounting nuts securing the fan shroud to the wing valance, then carefully withdraw the cooling fan assembly from underneath the wheel arch (see illustration). Recover any relevant mounting rubbers and spacers.

### Refitting - all models

- 11 Refitting is the reverse sequence to removal, noting that the mounting rubbers should be renewed if they show any signs of wear or deterioration. Ensure that all disturbed nuts and bolts are securely tightened.

## 8 Auxiliary cooling fan thermostatic switch - removal, testing and refitting



**Note:** Refer to the warnings given in Section 1 of this Chapter before proceeding.

### Removal

- 1 When the engine and radiator are cold, either drain the cooling system as described



7.10 Removing the lower fan mounting nut (arrowed) - fuel injection models



**8.3 Auxiliary cooling fan switch location (arrowed) - fuel injection models**

in Chapter 1, or carefully unscrew the radiator filler cap to release any remaining pressure, and have ready a suitable plug that can be used temporarily to stop the escape of coolant while the switch is removed. If the latter method is used, take care not to damage the threads, and do not use anything which will leave foreign matter inside the cooling system.

**2** On carburettor engine Cooper models, disconnect the wiring connectors, then unscrew the switch from the thermostat housing.

**3** On all other models, if necessary remove the front grille as described in Chapter 11 to improve access to the switch. Disconnect the two wiring connectors, then rotate the locking ring anti-clockwise to release it; withdraw the switch and rubber sealing ring from the bottom corner of the radiator (**see illustration**). Examine the sealing ring for signs of damage or deterioration, and renew if necessary.

### Testing

**4** To carry out a thorough test of the switch, use two spare wires to connect it either to a multimeter (set to the resistance function) or to a battery-and-bulb test circuit. Suspend the switch in a pan of water which is being heated. Measure the temperature of the water with a thermometer. Do not let either the switch or the thermometer touch the pan itself.

**5** The switch contacts should close to the "on" position (ie, continuity should exist) when the water reaches the specified switch-on temperature given in the *Specifications* at the start of this Chapter. Stop heating the water, and allow it to cool down; the switch contacts should open at the specified switch-off temperature.

**6** If the switch performance is significantly different from that specified, or if it does not work at all, it must be renewed.

### Refitting

**7** On carburettor engine Cooper models, ensure that the threads of the switch are clean, then apply a smear of suitable sealant to them. Refit the switch to the thermostat housing, tightening it to the specified torque, and reconnect the wiring connectors.

**8** On all other models, fit the sealing ring to the switch, then refit the switch to the radiator and secure it in position with the locking ring.

Reconnect the wiring connectors, and refit the front grille (where removed).

**9** On completion, either top-up or refill the cooling system as described in "Weekly Checks" or Chapter 1.

## 9 Heater water valve control cable - removal and refitting



### Removal

**1** Disconnect the battery negative lead.

**2** On pre-1989 models, slacken the inner cable trunion screw and the outer cable clamp screw at the heater water valve on the cylinder head. Release the cable from the valve. On 1989 models onward, release the outer cable retaining clip from the heater water valve on the engine compartment bulkhead. Disconnect the inner cable from the valve lever. Release the cable from its support clips.

**3** From inside the car, undo and remove the screws, securing the centre console (where fitted). This will enable the console to be moved slightly as necessary to provide access to the control cable and heater.

**4** Slacken the nut securing the rear of the heater unit to its mounting bracket.

**5** Undo and remove the two screws securing the heater unit to the parcel shelf and lower the heater.

**6** Detach the heater switch wire from the rear of the switch.

**7** Undo and remove the two nuts securing the switch panel to the bracket under the parcel shelf.

**8** Pull the switch panel forward slightly, undo the control cable retaining nut, and pull the complete cable through into the car. Recover the nut and washer from the end of the cable as it is pulled through.

### Refitting

**9** Refitting the cable is the reverse sequence to removal.

## 10 Heater water valve - removal and refitting



**Note:** Refer to the warnings given in Section 1 of this Chapter before proceeding.

### Removal

#### Pre-1989 models

**1** Drain the cooling system as described in Chapter 1.

**2** Slacken the clip and disconnect the heater hose from the valve.

**3** Slacken the inner cable trunion screw and the outer cable clamp screw at the water valve, and release the control cable from the valve.

**4** Undo the two nuts and remove the valve from the cylinder head studs.

#### 1989 models onwards

**5** Drain the cooling system as described in Chapter 1.

**6** Slacken the clips and disconnect the heater hoses from both sides of the valve (**see illustration**).

**7** Release the outer cable retaining clip and disconnect the control cable from the valve lever.

**8** Remove the valve assembly from the bulkhead.

### Refitting

**9** Refitting is the reverse sequence to removal, but check that the valve can be moved through its full range of travel. If necessary, adjust by repositioning the control outer cable in its clamp or retaining clip.

**10.6 Heater valve - 1989-on models**

- 1 Outer cable retaining clip
- 2 Inner cable attachment
- 3 Coolant hose clip
- 4 Coolant hose clip

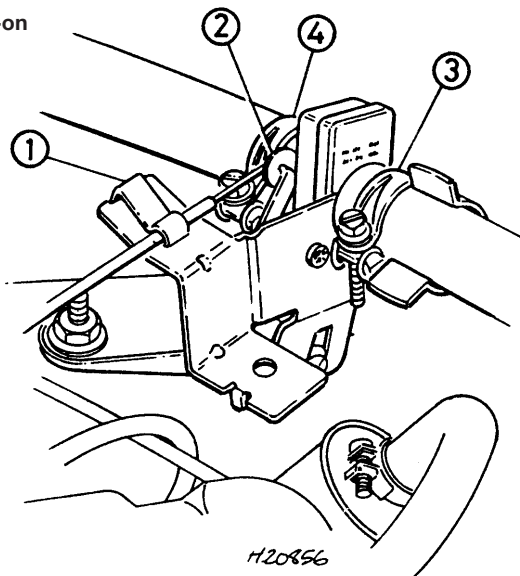



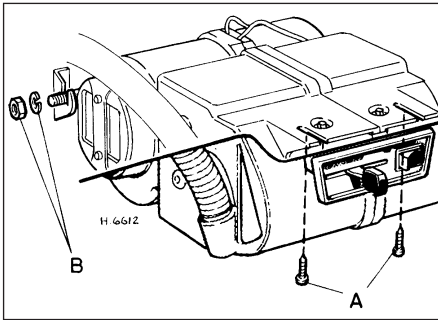

**11.14 Fresh air heater attachment points**

- A Securing screws - heater to parcel shelf  
 B Nut and spring washer - heater to rear bracket

## 11 Heater assembly - removal and refitting



**Note:** Refer to the warnings given in Section 1 of this Chapter before proceeding.

### Recirculating type (early models)

#### Removal

- 1 Disconnect the battery negative lead.
- 2 Refer to Chapter 1 and drain the cooling system.
- 3 Make a note of their relative positions, then disconnect the heater motor electric leads at the terminal connectors.
- 4 Slacken the demister and water hose clips.
- 5 To prevent water damage to the carpets or upholstery, place polythene sheeting in the appropriate places on the floor and seating.
- 6 Undo and remove the screws that secure the heater unit to the parcel shelf and carefully lift away the heater unit.

#### Refitting

- 7 Refitting is the reverse of removal, but the following additional points should be noted:
- a) Open the heater tap on the rear of the engine and slowly refill the cooling system as described in Chapter 1.
  - b) If the heater does not warm up, it is an indication that there is an air lock. To clear, disconnect the return hose from the lower radiator hose and plug the hole. Now extend the return hose to reach the radiator filler neck. Start the engine and observe the flow of water from the return hose. When the bubbles cease, switch off the engine and reconnect the hose.

### Fresh air type (later models)

#### Removal

- 8 Disconnect the battery negative lead.
- 9 Refer to Chapter 1 and drain the cooling system.
- 10 On models with a centre console, remove the console and the facia glovebox securing screws. This will enable the console to be moved as necessary for greater access to the heater.

- 11 To prevent water damage to the carpets or upholstery, place polythene sheeting in the appropriate places on the floor and seating.

12 Carefully pull the demister and air inlet tubes out of the heater unit.

13 Undo and remove the two screws that secure the front of the heater to the parcel shelf.

14 Slacken the nut that secures the rear of the heater to the body mounted bracket (see illustration).

15 Make a note of the electrical connections to the blower motor and switch, then disconnect the wires.

16 Slacken the clips and disconnect the heater water hoses.

17 Carefully lift the heater unit from the slotted rear brackets, hold the fingers over the matrix pipe ends (or plug with corks) and lift the unit from the car.

18 Finally drain any remaining coolant from the unit.

#### Refitting

19 Refitting the heater assembly is the reverse sequence to removal. Refill the cooling system as described in Chapter 1 on completion.

## 12 Heater assembly - dismantling and reassembly



### Recirculating type

#### Dismantling

- 1 Remove the heater assembly from the car as described in Section 11.
- 2 Detach the spring clips securing the demister flap to the cover plate and lift off the flap (see illustration).
- 3 Undo and remove the screws securing the cover plate to the cowl and lift off the cover plate and motor assembly.

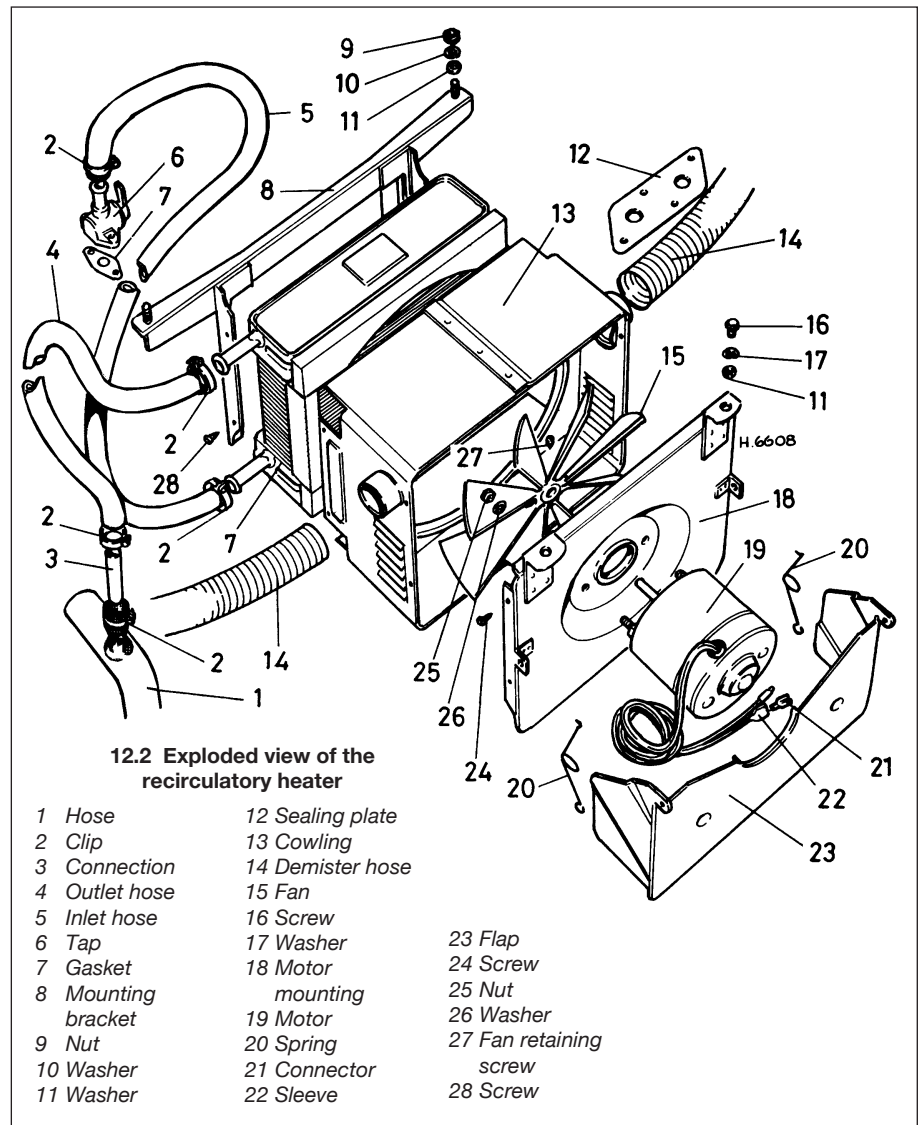



### 3•8 Cooling, heating and ventilation systems

**4** Prise the fan off the motor spindle, undo and remove the retaining nut and washer, then lift away the motor.

**5** Undo and remove the screws securing the mounting bracket to the cowling, lift off the mounting bracket and withdraw the heater matrix.

**6** Clean off all traces of rust and dirt from the matrix, and carefully inspect it for leaks or signs of excessive corrosion. The matrix should be renewed if it is badly corroded or leaking.

#### Reassembly

**7** Reassembly is the reverse of the dismantling procedure.

#### Fresh air type (first version)

##### Dismantling

**8** Remove the heater assembly from the car as described in Section 11.

**9** Undo and remove the two screws securing the control panel to the heater casing and lift off the panel (see illustration).

**10** Carefully prise off the spring retaining clips and separate the two halves of the casing.

**11** Withdraw the motor assembly and then lift out the heater matrix.

**12** The two rotors may be removed from the blower motor by releasing the retaining clips and sliding off the rotors.

**13** Clean off all traces of rust and dirt from the matrix, and carefully inspect it for leaks or signs of excessive corrosion. The matrix should be renewed if it is badly corroded leaking.

#### Reassembly

**14** Reassembly is the reverse of the dismantling procedure.

#### Fresh air type (second version)

##### Dismantling

**15** Remove the heater assembly from the car as described in Section 11.

**16** Detach the wire from the fan motor at the rear of the fan switch.

**17** Undo and remove the three screws and lift off the heater control mounting plate.

**18** Undo and remove the nine screws securing the right-hand end cover and lift off the cover.

**19** Carefully slide out the heater matrix.

**20** Undo and remove the screws securing the fan motor to the main casing, release the motor wires and grommet, and withdraw the motor assembly.

**21** If necessary, remove the two fans from the motor spindle.

**22** Clean off all traces of rust and dirt from the matrix, and carefully inspect it for leaks or signs of excessive corrosion. The matrix should be renewed if it is badly corroded or leaking. Note that on later models, the diameter and length of the heater inlet hose has been increased. If the heater matrix is to be renewed, it is important that the longer (1005.0 mm) hose is also fitted.

#### Reassembly

**23** Reassembly is the reverse of the dismantling procedure.

#### Fresh air type (third version - 1985 models onward)

##### Dismantling

**24** Remove the heater assembly from the car as described in Section 11.

**25** To remove the heater matrix, undo the two screws securing the matrix endplate, and withdraw the endplate, complete with matrix, from the heater casing.

**26** Undo two screws each, and lift the pipe stubs off the matrix endplate (see illustration).

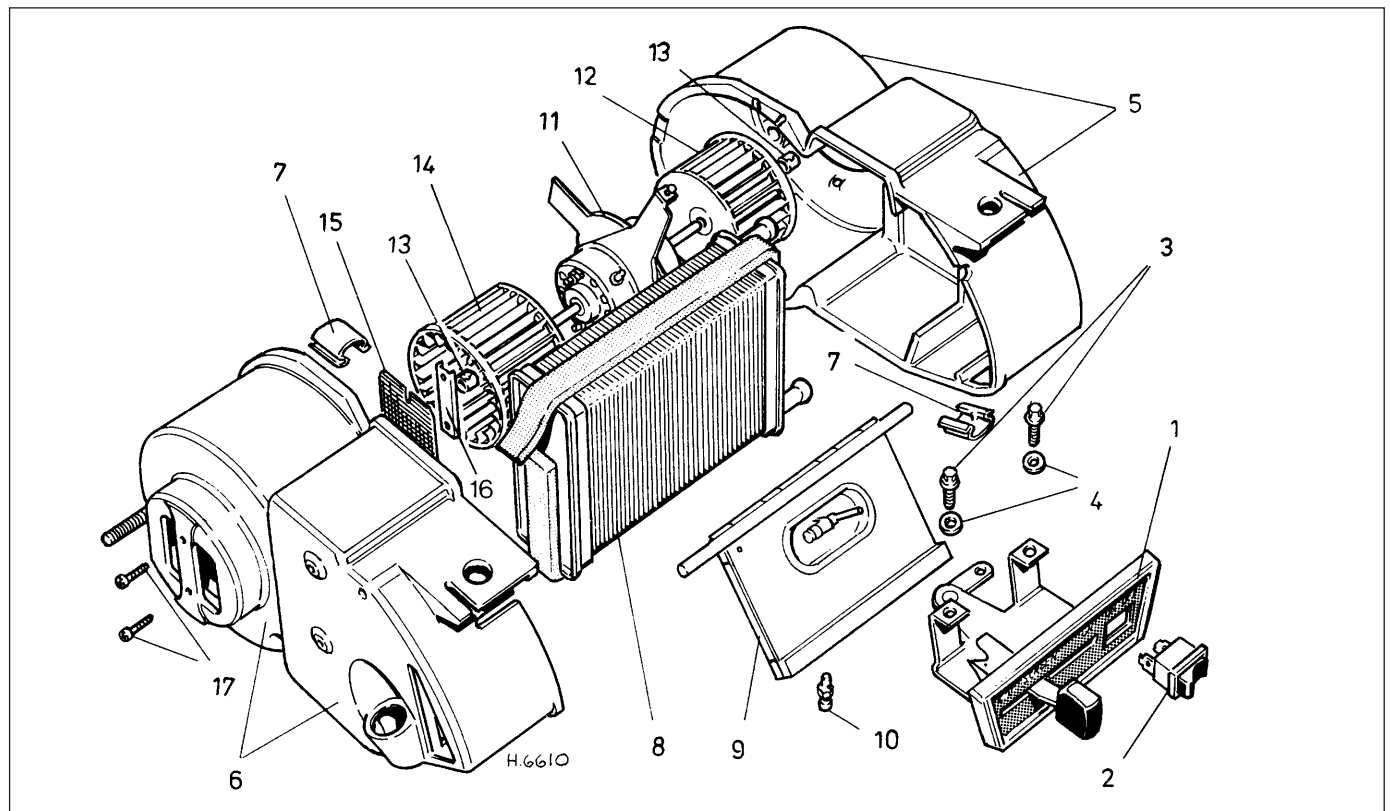

12.9 Exploded view of the early type fresh air heater

1 Control panel  
2 Fan switch  
3 Control panel  
securing screws

4 Washer  
5 Heater casing  
6 Heater casing

7 Retaining clip  
8 Matrix  
9 Air distribution flap

10 Trunnion screw  
11 Fan motor  
12 Air intake fan

13 Retaining clips  
14 Reciprocating fan  
15 Flap valve

16 Valve securing  
plate  
17 Valve securing  
screws

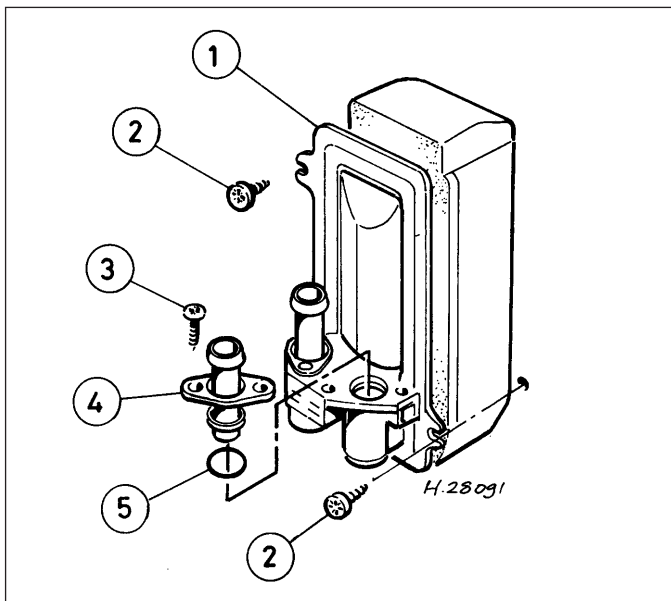

**12.26 Later-type heater matrix**

- |                             |                             |
|-----------------------------|-----------------------------|
| 1 Matrix endplate           | 3 Pipe stub retaining screw |
| 2 Endplate retaining screws | 4 Pipe stub                 |
|                             | 5 O-ring                    |

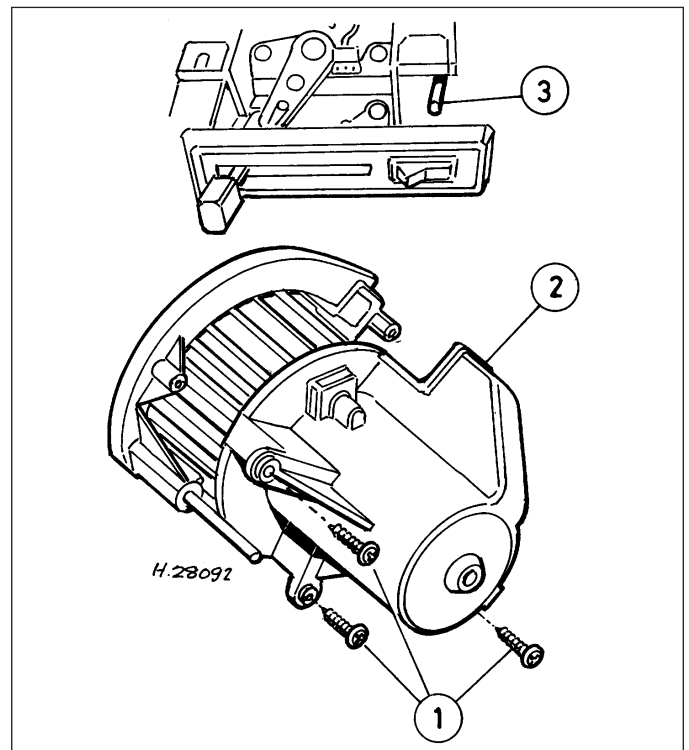

**12.29 Later-type heater motor**

- |                    |                           |
|--------------------|---------------------------|
| 1 Retaining screws | 3 Switch wiring connector |
| 2 Heater motor     |                           |

**27** Clean off the matrix, and carefully inspect it for leakage or corrosion. If it is leaking, renewal is recommended, as repairs are seldom successful unless done professionally.

**28** Inspect the condition of the O-rings on the pipe stubs, and renew if necessary.

**29** To remove the heater motor and fan, disconnect the motor switch wiring, undo the three screws, and withdraw the motor and fan from the casing (**see illustration**).

**30** Further dismantling of the motor and fan assembly is not possible, and if renewal is necessary, a complete assembly will be required.

**Reassembly**

**31** Reassembly is the reversal of the dismantling procedure.

**Refitting**

**3** Refitting is the reverse sequence to removal.

**13 Fresh air vent assembly - removal and refitting**



**Removal**

**1** Unscrew the fresh air vent retaining collar and lift away the binnacle (**see illustrations**).

**2** Turn the air vent anti-clockwise and remove it (**see illustration**).



**13.1a** Unscrew the fresh air vent retaining collar ...



**13.1b** ... and lift away the binnacle



**13.2** Turn the air vent anti-clockwise to remove





# Chapter 4 Part A:

## Fuel system - carburettor engines

### Contents

Accelerator cable - removal and refitting	3	Choke cable - removal and refitting	5
Accelerator pedal - removal and refitting	4	Electric fuel pump - testing, removal and refitting	6
Air cleaner assembly - removal and refitting	2	Fuel gauge sender unit - removal and refitting	8
Air cleaner element renewal	See Chapter 1	Fuel system components, checks and lubrication	See Chapter 1
Anti-run-on valve (1990-on Cooper models) - removal and refitting	17	Fuel tank - removal and refitting	9
Carburettor - general information	11	General information and precautions	1
Carburettor - removal and refitting	12	Inlet manifold - removal and refitting	18
Carburettor (SU HIF44 and HIF38) - fault diagnosis and overhaul	14	Mechanical fuel pump - testing, removal and refitting	7
Carburettor (SU HIF44 and HIF38) - idle speed and mixture adjustment	16	Underbody and fuel/brake line check	See Chapter 1
Carburettor (SU HS2 and HS4) - fault diagnosis and overhaul	13	Underbonnet check for fluid leaks and hose condition	See Chapter 1
Carburettor (SU HS2 and HS4) - idle speed and mixture adjustment	15	Unleaded petrol - general information and usage	10

### Degrees of difficulty

<b>Easy</b> , suitable for novice with little experience 	<b>Fairly easy</b> , suitable for beginner with some experience 	<b>Fairly difficult</b> , suitable for competent DIY mechanic 	<b>Difficult</b> , suitable for experienced DIY mechanic 	<b>Very difficult</b> , suitable for expert DIY or professional 
--	---	---	--	---

### Specifications

#### General

System type	Rear-mounted fuel tank, electric or mechanical fuel pump, single or twin SU variable choke carburettor
-------------	--

4A

#### Carburettor data

##### Mini 850 Saloon and variants, 848 cc, (85H)

	1969-72	1972-74	1974-76	1976 on
Carburettor type	SU HS2	SU HS2	SU HS4	SU HS4
Piston spring	Red	Red	Red	Red
Jet size	2.3 mm	2.3 mm	2.3 mm	2.3 mm
Needle:				
Standard	EB	AAV	ABS	ADH
Rich	M	-	-	-
Weak	GG	-	-	-
Idle mixture CO %	-	3.5 to 4.5	3.5 to 4.5	3.0 to 4.5
Idle speed	500 rpm	800 rpm	800 rpm	750 rpm
Fast idle speed	900 rpm	1200 rpm	1200 rpm	1200 rpm

##### Mini Clubman and Mini 1000 Saloon and variants, manual transmission, 998 cc, (99H), up to 1974

	1969-72	1972-74
Carburettor type	SU HS2	SU HS2
Piston spring	Red	Red
Jet size	2.3 mm	2.3 mm
Needle:		
Standard	GX	AAV
Rich	M	-
Weak	GG	-
Idle mixture CO %	-	3.5 to 4.5
Idle speed	500 rpm	800 rpm
Fast idle speed	900 rpm	1200 rpm

## 4A•2 Fuel system - carburettor engines

### Mini Clubman and Mini 1000 Saloon, automatic transmission, 998 cc, (99H), up to 1974

Carburettor type	SU HS4
Piston spring	Red
Jet size	2.3 mm
Needle:	
Standard	AC
Rich	MI
Weak	HA
Idle speed	650 rpm
Fast idle speed	1050 rpm

### Mini Clubman and Mini 1000 Saloon and variants, manual and automatic transmission, 998 cc, (99H), 1974-83

	1974-76	1976-78	1978-83
Carburettor type	SU HS4	SU HS4	SU HS4
Piston spring	Red	Red	Red
Jet size	2.3 mm	2.3 mm	2.3 mm
Needle	ABX	ADE	ADE
Idle mixture CO %	3.5 to 4.5	3.0 to 4.5	3.0
Idle speed	750 rpm	750 rpm	750 rpm
Fast idle speed	1200 rpm	1250 rpm	1250 rpm

### Mini Saloon and variants, manual and automatic transmission, 998 cc (99H), 1983-89

Carburettor type	SU HS4
Piston spring	Red
Jet size	2.3 mm
Needle	AAC
Idle mixture CO %	2.5 ± 1.0
Idle speed	750 ± 50 rpm
Fast idle speed	1100 ± 50 rpm

### Mini Saloon and variants, manual and automatic transmission, 998 cc (99H), 1989-on

	(low compression)	(high compression)
Carburettor type	SU HS4	SU HS4
Piston spring	Red	Red
Jet size	2.3 mm	2.3 mm
Needle	ADE	AAC
Idle mixture CO %	2.5 ± 1.0	2.5 ± 1.0
Idle speed	750 ± 50 rpm	750 ± 50 rpm
Fast idle speed	1100 ± 50 rpm	1100 ± 50 rpm

### Mini Clubman 1100, 1098 cc, (10H)

	1974 on
Carburettor type	SU HS4
Piston spring	Red
Jet size	2.3 mm
Needle	ABP
Idle mixture CO %	3.0 to 4.5
Idle speed	750 rpm
Fast idle speed	1150 to 1300 rpm

### Mini Cooper S Mk III, 1275 cc, (12H)

	1969 on
Carburettor type	Twin SU HS2
Piston spring	Red
Jet size	2.3 mm
Needle:	
Standard	M
Rich	AH2
Weak	EB
Idle speed	600 rpm
Fast idle speed	1000 rpm

### Mini 1275 GT, 1275 cc, (12H)

	1969-72	1972-76	1976-77	1978 on
Carburettor type	SU HS4	SU HS4	SU HS4	SU HS4
Piston spring	Red	Red	Red	Red
Jet size	2.3 mm	2.3 mm	2.3 mm	2.3 mm
Needle:				
Standard	AC	AAV	ABB	AAT
Rich	BQ	-	-	-
Weak	HA	-	-	-
Idle mixture CO %	-	3.5 to 4.5	3.0 to 4.5	3.0 to 4.0
Idle speed	650 rpm	800 rpm	850 rpm	750 rpm
Fast idle speed	1050 rpm	1200 rpm	1300 rpm	1300 rpm



**Mini Cooper, 1275 cc, (12A)**

Carburettor type .....	1990-on
Piston spring .....	SU HIF44
Jet size .....	Red
Needle .....	2.5 mm
Idle mixture CO % .....	BFY
Idle speed .....	1.6 to 3.0 (measured at gas sampling pipe)
Fast idle speed .....	900 rpm
	1200 ± 50 rpm

**Mini Saloon and variants, 1275 cc (12A)**

Carburettor type .....	1992-on
	SU HIF38

At the time of writing, no further specifications were available for this model.

**Recommended fuel**

Minimum octane rating (see text Section 10):

All pre-1989 models* .....	97 RON leaded
1989-on, 998 cc low-compression models .....	95 RON unleaded or 90 RON leaded
1989-on, 998 cc high-compression models .....	95 RON unleaded or 97 RON leaded
1990-on 1275 cc (12A) models .....	95 RON unleaded <b>only</b>

\*Pre-1989 models with a "Green pack" can be run on 95 RON unleaded petrol - see text for further information.

**Note:** Models with a catalytic converter **must** be run on unleaded petrol **only**.

**Torque wrench setting**

	<b>Nm</b>	<b>lbf ft</b>
Manifold retaining nuts .....	22	16

**1 General information and precautions**

**General information**

The fuel system comprises a fuel tank, an electric or mechanical fuel pump and a variable choke carburettor.

The fuel tank is located in the luggage compartment on Saloon models, and beneath the rear floor on the Estate, Van and Pick-up variants. On Cooper S versions twin fuel tanks are used, these being positioned on either side of the luggage compartment.

A number of the earlier vehicles covered by this manual are equipped with an SU electric fuel pump which is mounted on the left-hand member of the rear subframe. All later Mini models utilise a mechanical fuel pump bolted to the rear of the engine and operated by an eccentric on the camshaft.

A variable choke carburettor of SU manufacture is fitted to all models. Manual transmission versions manufactured up to 1974 utilise a single SU HS2 unit, the exception to this being the Cooper S model which incorporates a twin carburettor installation. Later vehicles are equipped with the larger SU HS4 carburettor, or its derivatives the HIF38 and HIF44. Further information on carburettor types will be found later in this Chapter.

Certain models are fitted with emission control equipment to reduce the level of harmful emissions in the exhaust gases. Information on the exhaust and emission control systems is contained in Part C of this Chapter.

**Precautions**



**Warning:** Petrol is extremely flammable - great care must be taken when working on any part of the fuel system. Do not smoke

or allow any naked flames or uncovered light bulbs near the work area. Note that gas powered domestic appliances with pilot flames, such as heaters, boilers and tumble dryers, also present a fire hazard - bear this in mind if you are working in an area where such appliances are present. Always keep a suitable fire extinguisher close to the work area and familiarise yourself with its operation before starting work. Wear eye protection when working on fuel systems and wash off any fuel spilt on bare skin immediately with soap and water. Note that fuel vapour is just as dangerous as liquid fuel; a vessel that has just been emptied of liquid fuel will still contain vapour and can be potentially explosive. Petrol is a highly dangerous and volatile liquid, and the precautions necessary when handling it cannot be overstressed.



Many of the operations described in this Chapter involve the disconnection of fuel lines, which may cause an amount of fuel spillage. Before commencing work, refer to the above Warning and the information in "Safety first" at the beginning of this manual.



When working with fuel system components, pay particular attention to cleanliness - dirt entering the fuel system may cause blockages which will lead to poor running.

**2 Air cleaner assembly - removal and refitting**



**All models except Cooper, and 1992-on models with open-loop catalytic converter**

**Removal**

- 1 Undo and remove the single wing nut and washer on early models, or the twin wing bolts and washers on later models, securing the air cleaner to the carburettor (see illustrations).
- 2 If the air cleaner is retained by a single wing nut lift off the air cleaner top cover. Detach the rocker cover hose, then lift the air cleaner body off the carburettor, tip it up at the front and slide it sideways until it is clear of the long retaining stud and can be lifted away. Recover the sealing ring (see illustrations).

**4A**



2.1a Remove the single wing nut on early models . .



2.1b . . . or the two wing bolts on later models



2.2a If the air cleaner is retained by a single wing nut, lift off the top cover and withdraw the air cleaner body from the carburettor

3 If the air cleaner is retained by two wing bolts, detach the hot air duct (where fitted) and then lift the air cleaner body off the carburettor (see illustrations).

4 With the air cleaner removed from the engine, recover the rubber sealing ring if it stayed behind on the carburettor flange.

**Refitting**

5 Refitting the air cleaner is the reverse sequence to removal. Ensure also that the rubber sealing ring is in position before refitting the air cleaner.

6 If the air cleaner body incorporates an

adjustable air inlet spout, this should be positioned adjacent to the exhaust manifold in winter and away from it in summer.

**Cooper S Mk III models**

**Removal**

7 Undo and remove the two wing bolts and washers then disconnect the engine breather pipe and the throttle return spring. Lift off the air cleaner body and recover the two rubber sealing rings from the carburettor flanges.

**Refitting**

8 Refitting is the reverse sequence to removal but ensure that the rubber sealing rings are in position on the carburettor's flanges.

**1990-on Cooper models**

**Removal**

9 Unscrew the two nuts securing the air inlet duct to the rocker cover studs, then release the clip and disconnect the duct from the air cleaner (see illustration).

10 Unscrew and remove the nuts and washers, then lift the air cleaner from the carburettor and disconnect the hot air hose. Remove the sealing ring from the carburettor flange.



2.2b Recover the sealing ring



2.3a If the air cleaner is retained by two wing bolts detach the hot air duct . . .



2.3b . . . and lift off the air cleaner body . . .

**Refitting**

11 Refitting is the reverse sequence to removal but ensure that the rubber sealing ring is in position on the carburettors flange.

**1992-on models with open-loop catalytic converter**

**Removal**

12 Unscrew the two wing nuts, and lift the air cleaner assembly away from the carburettor. Recover the sealing ring from the carburettor flange.

**Refitting**

13 Refitting is the reverse sequence to removal but ensure that the rubber sealing ring is in position on the carburettors flange.

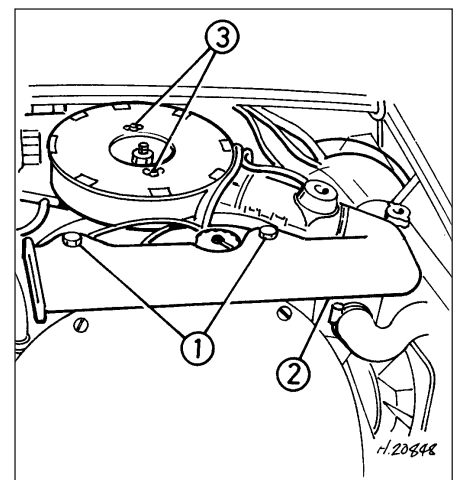

2.9 Air cleaner and intake duct fitted to 1990-on Cooper models

- 1 Intake duct retaining nuts
- 2 Intake duct
- 3 Air cleaner mounting nuts

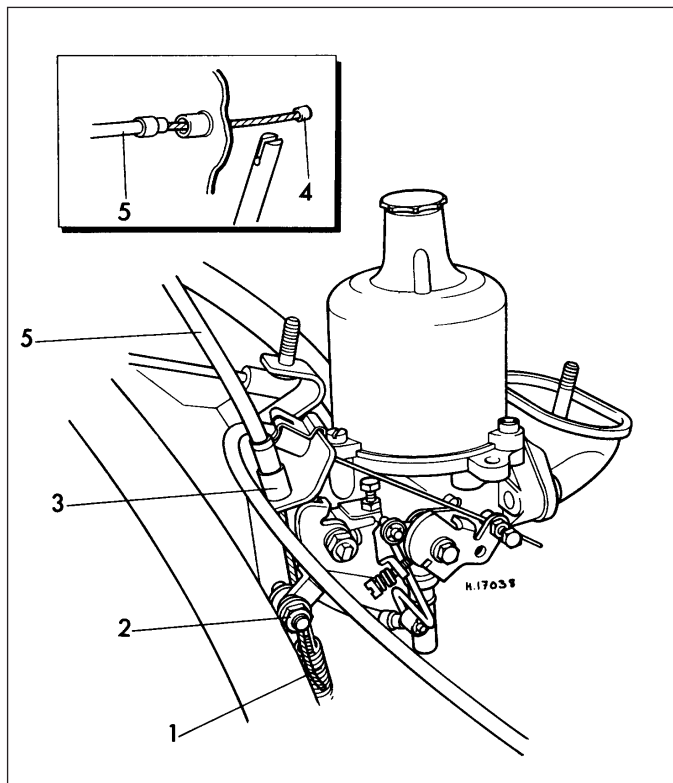

3.1 Accelerator cable attachments

- |                           |   |
|---------------------------|---|
| 1 Throttle return spring  | 3 Cable support bracket                   |
| 2 Cable-to-throttle lever | 4 Cable ferrule – pedal end securing bolt |
|                           | 5 Outer cable                             |

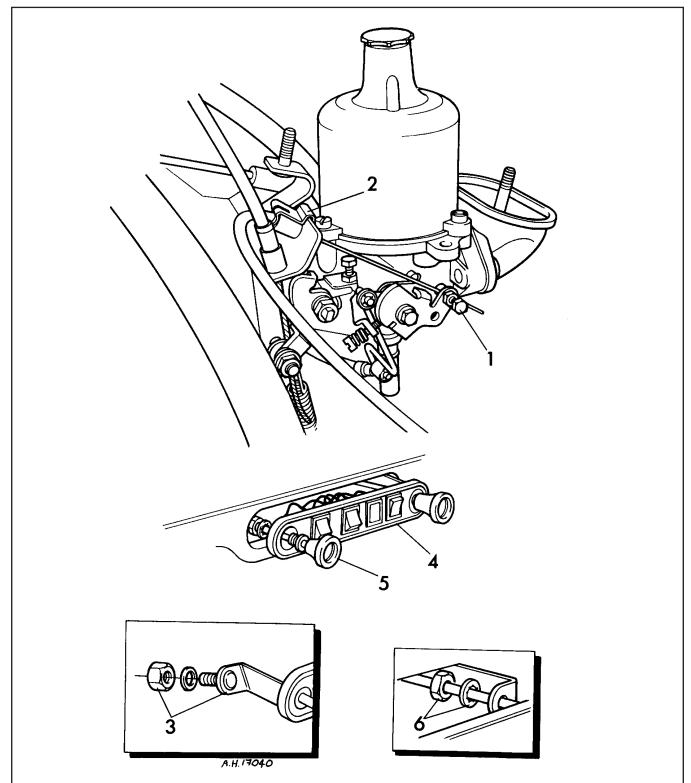

5.3 Choke cable attachments

- |                                     |                                  |
|-------------------------------------|----------------------------------|
| 1 Inner cable-to-linkage attachment | 4 Switch panel                   |
| 2 Outer cable support bracket       | 5 Choke cable                    |
| 3 Switch panel retaining nuts       | 6 Cable retaining nut and washer |

### 3 Accelerator cable - removal and refitting



#### Removal

- Working in the engine compartment, disconnect the throttle return spring(s) and undo the nut and washer securing the cable to the bolt on the throttle lever (see illustration). On later models the cable is attached to the throttle lever by means of a small clamp with a locking bolt through its centre. Hold the clamp and unscrew the bolt using either 4 BA or 7 BA spanners according to clamp type.
- Pull the cable through the bolt or clamp and slide it out of the steady bracket on the rocker cover (if fitted).
- From inside the car, depress the accelerator pedal and withdraw the ferrule on the cable from the slot in the top of the pedal arm.
- The cable can now be withdrawn through the opening in the bulkhead and into the engine compartment.

#### Refitting

- To refit the cable, feed it through the

bulkhead and engage the ferrule into the slot on the pedal arm.

- Now feed the other end of the cable through the brackets on the rocker cover and carburettor, and then insert the inner cable into the slotted bolt or clamp on the throttle lever.
- Pull the cable through the bolt to take up any slack and then refit the washer and nut or the clamp locking bolt. Avoid straining or distorting the cable as the fixings are tightened.
- Reconnect the return spring and check that a slight amount of free play exists between the pedal and cable.
- Start the engine and check the operation of the cable.

### 4 Accelerator pedal - removal and refitting



#### Removal

- Depress the accelerator pedal and detach the accelerator cable ferrule from the slot at the top of the pedal arm.
- Undo and remove the two bolts securing the pedal assembly to the bulkhead and lift out the pedal.

#### Refitting

Refitting is the reverse sequence to removal.

### 5 Choke cable - removal and refitting



#### Removal

**Note:** On models fitted with a centre console it will be necessary to remove the centre console and console glovebox retaining screws. This will allow the console to be moved slightly to provide access for the following operations.

- Disconnect the battery negative lead.
- Refer to Section 2 and remove the air cleaner assembly.
- Working in the engine compartment, disconnect the choke inner cable from the trunnion screw on the choke linkage and the outer cable from the support bracket (see illustration). Withdraw the complete cable from the carburettor.
- From inside the car, undo and remove the two screws securing the heater assembly to the front of the parcel shelf. Now lower the heater slightly at the front.

**5** Disconnect the heater switch wires from the switch.

**6** Undo and remove the two nuts or screws which secure the auxiliary switch panel to the centre of the parcel shelf.

**7** Draw the switch panel forward and unscrew the choke cable retaining nut, or extract the retaining clip (according to type) from the rear of the panel.

**8** Pull the complete cable through the bulkhead grommet and switch panel, into the passenger compartment. Recover the retaining nut and lockwasher from the end of the cable.

### Refitting

**9** To refit the cable, slide it through the slot in the switch panel and then place the nut and washer over the cable.

**10** Insert the cable through the bulkhead grommet and through to the engine compartment.

**11** Screw on and fully tighten the choke cable retaining nut or refit the clip then refit the switch panel. Position the word LOCK on the cable knob at the top to ensure correct operation in use. Reconnect the heater switch leads and refit the heater securing screws.

**12** Engage the other end of the cable into the support bracket and the inner cable into the trunnion on the choke linkage.

**13** Ensure that the choke cable is pushed fully in, ie in the "off" position, then tighten the retaining screws on the support bracket and cable trunnion. Ensure that there is 1.5 mm of free play on the cable before the cable starts to operate the choke linkage.

**14** Refit the air cleaner, reconnect the battery and, where applicable, refit the centre console retaining screws.

## 6 Electric fuel pump - testing, removal and refitting



**Note:** Observe the precautions in Section 1 before working on any component in the fuel system.

### Testing

**1** To test the fuel pump, disconnect the fuel supply hose at the top of the carburettor float chamber and immerse the end of the hose in a clean glass jar. With the ignition switched on there should be a steady flow of petrol from the end of the hose accompanied by a regular ticking noise from the pump.

**Warning:** Carry out this operation in a well ventilated area and take great care not to splash fuel onto hot engine components.

**2** A rapid irregular ticking noise accompanied by a mixture of fuel and air bubbles flowing from the hose is indicative of an air leak on the suction side of the pump (ie in the pipe between the pump and fuel tank). This will ultimately lead to fuel starvation and cutting out or misfiring if not corrected.

**3** No fuel flow from the supply hose indicates a fault in the pump (perforated diaphragm, dirty contact points etc), or a break in the electrical supply to the pump. If the electrical supply to the pump is sound but the pump is still not functioning, it should be taken to an auto-electrician for inspection and possible repair, or replaced with an exchange unit. Repair kits are unlikely to still be available from normal sources so an exchange unit may be the only alternative.

### Removal

**4** Disconnect the battery negative lead.

**5** Chock the front wheels then jack up the rear of the car and support it on axle stands (see "Jacking and vehicle support").

**6** Working under the car, disconnect the earth lead and the electrical supply wire from their terminals on the pump body.

**7** Prepare to squeeze the rubber portion of the petrol pipe leading from the tank with a self-gripping wrench or similar tool, to ensure that the minimum amount of fuel is lost when the inlet pipe is removed from the pump. Plug the end of the pipe with a bolt or metal rod of suitable diameter immediately it is disconnected.

**8** Remove the inlet and outlet fuel pipes by undoing the retaining clip screws and easing the pipes off the pump nozzles (see illustration). Remove the vent pipe connector, if fitted, at this stage.

**9** Undo and remove the two nuts, bolts and spring washers securing the pump bracket to the subframe and lift off the pump assembly, complete with bracket and clamp.

**10** To separate the pump from the bracket, slacken the clamp bolt and slide the pump out of the clamp.

### Refitting

**11** Refitting is the reverse sequence to removal, bearing in mind the following points:

- Arrows on the pump body indicate the correct locations of the inlet and outlet pipes. Ensure that these are fitted correctly and that the pump is installed with the outlet pipe at the top.
- Ensure that the electrical leads, particularly the earth, are clean and that a correct connection is made.



**6.8** Removing the fuel outlet pipe from the electric pump

## 7 Mechanical fuel pump - testing, removal and refitting



**Note:** Observe the precautions in Section 1 before working on any component in the fuel system.

### Testing

**1** To test the fuel pump, disconnect the fuel supply hose at the top of the carburettor float chamber and immerse the end of the hose in a clean glass jar. With an assistant cranking the engine on the starter, regular spurts of fuel should be ejected as the engine turns.



**Warning:** Carry out this operation in a well ventilated area and take great care not to splash fuel onto hot engine components.

**2** If the pump does not operate satisfactorily, it should be renewed. The AUF 700 series pump fitted to early models may be dismantled for inspection, but repair kits are unlikely to still be available from normal sources. The AUF 800 series pump fitted to later models is a sealed unit and cannot be dismantled.

### Removal

**Note:** The fuel pump used on later models (1985-on) is different in appearance to those used previously, but is fully interchangeable. A modified kickdown rod will be required if a new type pump is fitted to older vehicles with automatic transmission. Details of the rod fitment should be obtained from your dealer.

**3** Disconnect the battery negative lead.

**4** To provide greater access, remove the air cleaner, as described in Section 2.

**5** Slacken the pipe clip screw on the outlet pipe connection and draw it off. Have a small container handy to collect what little fuel may drain from the pipe.

**6** In all Saloon models, if the tank is more than half full, the fuel will drain from the tank under gravity when the fuel pump inlet pipe is disconnected, so provide for this situation by fitting a suitable clip or bung in the pipe if necessary. On all other models the tank is below the pump level, so this problem will not occur. Slacken the pipe clip screw on the inlet pipe connection and draw it off.

**7** Slacken the two nuts which hold the pump to the crankcase on two studs through the lower body.

**8** Ease the pump away from the crankcase slightly and release the insulating block and its two sealing gaskets. If they are stuck, carefully prise them off the crankcase using a knife or thin screwdriver. Now lift off the pump, insulating block and gaskets.

### Refitting

**9** Refitting the pump is the reverse sequence to removal bearing in mind the following points:

- Ensure that the mating faces of the pump and crankcase are thoroughly clean and dry.



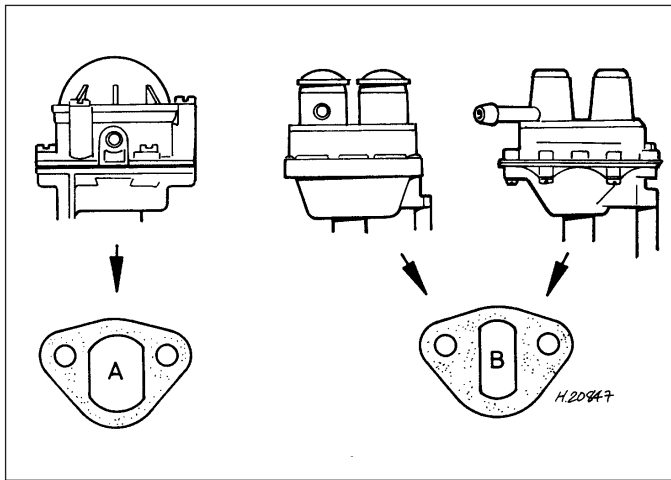

7.9 Mechanical fuel pump insulator block types

A 700 series type

B 800 and AZX series type



8.1 Electrical leads at the fuel gauge sender unit on the side of the tank (Saloon models)

- b) Ensure that the correct insulator block is used according to pump type. The insulator block fitted to the 700 series pump is different from the insulator block fitted to 800 series and AZX series pumps (see illustration). The 700 series pump requires an insulator block with a large inner aperture, whereas the 800 series and AZX pumps require an insulator block with a small aperture in order to retain the pump lever pivot. If the wrong insulator block is fitted, there is a possibility of the pivot and lever dropping into the sump/transmission.
- c) Use new sealing gaskets on either side of the insulating block but make sure that the original thickness is maintained otherwise the pump operation may be affected.

tank, ensuring that the float lever is not bent or damaged in the process.

**Estate, Van and Pick-up models**

- 4 Refer to Section 9 and remove the fuel tank from the car.  
 5 Removal and refitting of the sender unit now follows the procedure described for Saloon models.

**Refitting**

6 Refitting the unit is the reverse sequence to removal. To ensure a fuel-tight joint, scrape both the tank and sender unit mating flanges clean, and always use a new joint gasket and a suitable gasket sealer.

4 Remove the spare wheel from its location in the luggage compartment.

5 Disconnect the wiring from the fuel gauge sender unit located on the side of the tank (see illustration).

6 If the car is fitted with an electric fuel pump, slacken the clip and detach the fuel inlet hose from the pump inlet nozzle. Collect any remaining fuel in a suitable container.

7 When the tank is empty, slacken the clip and detach the fuel hose from the front of the tank.

8 Detach the fuel tank breather pipe and remove the filler cap.

9 Undo and remove the tank securing strap bolt and carefully manoeuvre the fuel tank from the luggage compartment.

10 If the tank is contaminated with sediment or water, remove the fuel gauge sender unit as described in Section 8 and swill the tank out with clean fuel. If the tank is damaged or corroded it should be renewed. However, in certain cases it may be possible to have small leaks or minor damage repaired. Seek the advice of a Rover dealer or suitable specialist concerning tank repair.

**Refitting**

11 Refitting is the reverse sequence to removal.

**Estate, Van and Pick-up models**

12 Disconnect the battery negative lead.

13 Chock the front wheels then jack up the rear of the car and support it on axle stands (see "Jacking and vehicle support").

14 Remove the tank filler cap then, from underneath the car, undo and remove the drain plug, allowing the fuel to drain into a suitable container. Do this in a well ventilated area, not in a garage or over an inspection pit. When drained, refit the drain plug and washer securely.

4A

**8 Fuel gauge sender unit - removal and refitting**



**Note:** Observe the precautions in Section 1 before working on any component in the fuel system.

**Removal**

**Saloon models**

1 Disconnect the battery negative lead and remove the fuel gauge wires from their attachments to the sender unit mounted in the side of the tank (see illustration).

2 On early models, unscrew the screws which hold the gauge unit to the tank carefully, and lift the complete unit away, ensuring that the float lever is not bent or damaged in the process.

3 On later models, using crossed screwdrivers, remove the fuel gauge sender unit by turning the locking ring through 30° and lifting away. Carefully lift the unit from the

**9 Fuel tank - removal and refitting**



**Note:** Observe the precautions in Section 1 before working on any component in the fuel system.

**Saloon models except Cooper S**

**Removal**

1 Before the tank can be removed, it must be drained of as much fuel as possible. To avoid the dangers and complications of fuel handling and storage, it is advisable to carry out this operation with the tank almost empty. Any fuel remaining can be drained as follows.  
 2 Disconnect the battery negative lead.

3 Using a hand pump or syphon inserted through the filler neck, remove any remaining fuel from the bottom of the tank. **Note:** A number of earlier models were fitted with a fuel tank incorporating a combined drain plug and tube. Access to this is from below the car, using a long box spanner. In all cases carry out the draining or siphoning operation in a well ventilated area, never in a garage or over an inspection pit.

**15** Disconnect the fuel outlet pipe and the fuel gauge wires from their connections on the sender unit on the side of the tank (**see illustration**).

**16** Undo and remove the six screws which hold the tank in place and remove the tank. It is helpful if a jack is positioned under the tank as the retaining screws are removed so that the tank does not drop out under its own weight. It may also be found easier to lower the tank slightly on the jack before disconnecting the sender unit leads, as with the tank half removed they are more accessible.

**17** Refer to the information contained in paragraph 10.

### Refitting

**18** Refitting the tank is the reverse sequence to removal bearing in mind the following points:

- a) Make sure that the nylon spacers located at each retaining screw hole are in position before refitting the tank.
- b) Ensure that the drain plug and washer are in place and securely tightened.
- c) Ensure that the rubber ferrule beneath the filler cap makes an effective seal with the body.

### Cooper S twin fuel tanks

#### Removal

**19** Disconnect the battery negative lead.

**20** Working in the rear luggage compartment remove the trimmed floor panel.

**21** Lift out the spare wheel.

**22** Remove the fuel filler caps.

**23** Unscrew the left-hand fuel tank drain plug three turns and allow fuel to drain from both tanks into a suitable container. Do this in a well ventilated area, not in a garage or over an inspection pit. When drained, resecure the drain plug.

#### Left-hand tank

**24** Disconnect the electrical connectors from the fuel gauge sender unit.

**25** Remove the tank strap securing bolt.

**26** Detach the flexible pipe and the vent pipe from the fuel tank.

**27** Carefully ease the fuel tank towards the centre of the luggage compartment and lift away.

**28** Refer to the information contained in paragraph 10.

#### Right-hand tank

**29** Completely remove the battery, referring to Chapter 5A if necessary.

**30** Remove the tank strap securing bolt.

**31** Detach the flexible hose from the left-hand tank.

**32** Move the tank slightly from its mountings, taking extreme care not to damage the flexible fuel pipes.

**33** The fuel tank will still contain a small amount of petrol which should be drained into a small container when the flexible fuel pipe is disconnected.

**34** Disconnect the flexible fuel pipe.

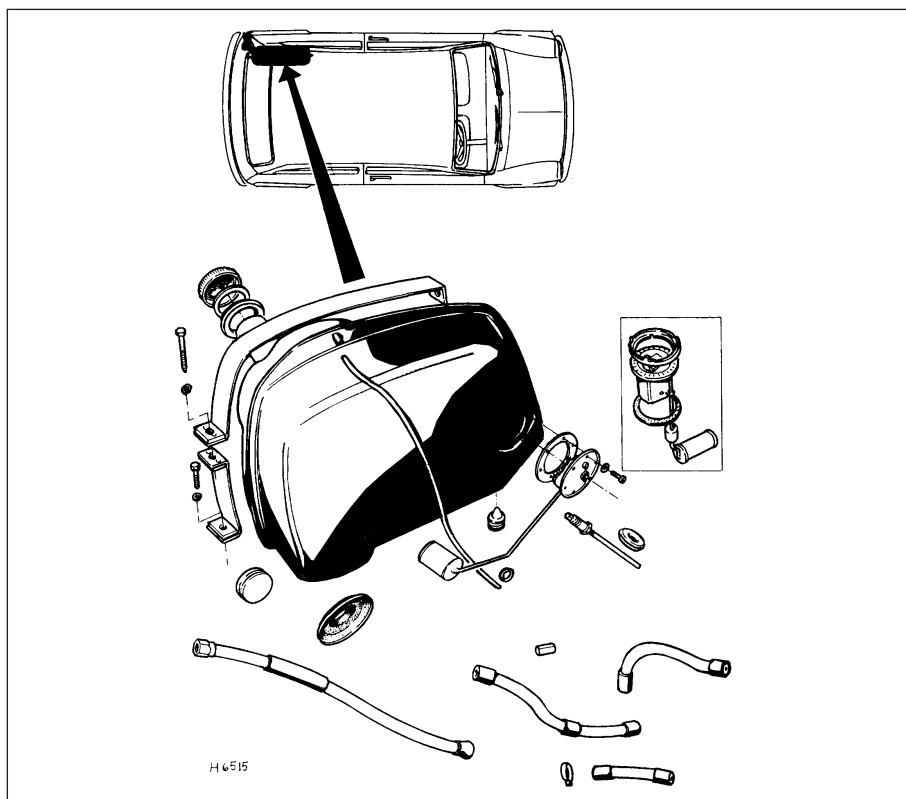

**9.5 Fuel tank and fittings – Saloon models**

**35** Finally detach the vent pipe from the tank and lift the tank from the car.

**36** Refer to the information contained in paragraph 10.

### Refitting

**37** Refitting either fuel tank is the reverse sequence to removal. Make sure that the seal around the drain plug housing is water-tight.

## 10 Unleaded petrol - general information and usage

**Note:** The information given in this Chapter is correct at the time of writing. If updated information is thought to be required, check



**9.15 Fuel tank outlet pipe and fuel gauge sender unit (Estate, Van and Pick-up models)**

with a Rover dealer. If travelling abroad, consult one of the motoring organisations (or a similar authority) for advice on the fuel available.

**1** The fuel recommended by Rover is given in the Specifications Section of this Chapter.

**2** Models built up to October 1988 (as delivered from the factory) cannot use unleaded petrol; the valve seats fitted as standard will suffer serious premature wear without the protection of the petrol's lead content. Only four-star leaded petrol should be used, irrespective of the engine's compression ratio. Exceptions to this are those engines which have been modified as described in paragraph 5 below.

**3** From October 1988 onwards (ie during the 1989 model year), improved components were gradually introduced at the factory to enable engines to run on 95 RON unleaded petrol; these vehicles can be identified by the green "95 RON unleaded petrol" label attached to the bonnet lock platform. These vehicles can use either unleaded or leaded petrol, without modification or risk of damage.

**4** If you have a 1989 model and suspect that the label has become detached, check first with a Rover dealer whether the vehicle can or cannot use unleaded petrol; the VIN (Vehicle Identification Number) will be required for positive identification. Note, however, that as a general rule, 998 cc engines which can use unleaded petrol have the engine serial number prefix "99HE".

**5** To use unleaded petrol on earlier models, conversion kits are available (consisting basically of an exchange cylinder head known as "Green Packs"), through Rover dealers. Any vehicle which has had such a conversion will have the letter "U" stamped between the engine prefix and the start of the serial number, and can use either unleaded or leaded petrol without modification. **Note:** *Apart from any adjustment made during the fitting of a "Green Pack" no alteration should be made to the ignition timing or carburation settings.*

**6** Models equipped with a catalytic converter must be run on **unleaded petrol only**.

## 11 Carburettor - general information

### SU HS2 and HS4

The variable choke SU HS2 and HS4 carburettors are relatively simple instruments and are basically the same irrespective of type. They differ from most other carburettors in that, instead of having a number of various sized fixed jets for different conditions, only one variable jet is fitted to deal with all possible conditions.

The carburettor comprises four main assemblies; these are the carburettor body, the piston and dashpot assembly, the jet assembly and the float chamber. Fuel is carried from the float chamber to the base of the jet head by a nylon pipe, the float chamber being secured to the carburettor body by a horizontally positioned bolt and spacing washer.

The operation of the carburettor is as follows. Air passing rapidly through the carburettor creates a slight vacuum or depression over the jet, causing fuel to be drawn into the air stream, thus forming the fuel/air mixture. The amount of fuel drawn from the jet depends on the position of the tapered carburettor needle. This moves up or down the jet orifice according to engine load or throttle opening, thus effectively altering the size of the jet. This allows the right amount of fuel to be delivered for the prevailing road conditions.

The position of the tapered needle in the jet is determined by engine vacuum. The shank of the needle is held at its top end in a piston, which slides up and down the dashpot, in response to the degree of manifold vacuum. This is directly controlled by the throttle. The piston is necessary so that the depression over the jet needed to draw fuel into the air stream, can be kept approximately constant. At slow engine speeds, the air entering the carburettor would not be travelling fast enough to create sufficient vacuum to draw fuel from the jet. By allowing the piston to partially restrict the opening through the carburettor, the incoming air is speeded up, causing an adequate depression over the jet.

With the throttle fully open, the full effect of inlet manifold vacuum is felt by the piston, which has an air bleed into the carburettor venturi on the outside of the throttle. This causes the piston to rise fully, bringing the needle with it. With the throttle partially closed, only slight inlet manifold vacuum is felt by the piston (although on the engine side of the throttle, the vacuum is now greater), and the piston only rises slightly.

To prevent piston flutter, and to give a richer mixture when the accelerator is suddenly depressed, an oil damper and light spring are located inside the dashpot.

For cold starting, when fuel enrichment is necessary and very small amounts of air are drawn into the carburettor, actuation of the choke control causes the jet head to be lowered, thus effectively increasing the jet size.

The only portion of the piston assembly to come into contact with the piston chamber or dashpot is the actual central piston rod. All the other parts of the piston assembly, including the lower choke portion, have sufficient clearances to prevent any direct metal-to-metal contact, which is essential if the carburettor is to work properly.

The correct level of the petrol in the carburettor is determined by the level of the float in the float chamber. When the level is correct, the float rises and, by means of a lever resting on top of it, closes the needle valve in the cover of the float chamber. This closes off the supply of fuel from the pump. When the level in the float chamber drops, as fuel is used in the carburettor, the float sinks. As it does, the float needle comes away from its seat so allowing more fuel to enter the float chamber and restoring the correct level.

### SU HIF44 and HIF38

The SU HIF44 and HIF38 carburettors are fitted to 1990-on Cooper models, and 1992-on 1275 cc models with open-loop catalytic converter respectively. These carburettors operate in a similar way to the SU HS2 and HS4 instruments described previously, but the float chamber has been incorporated into the main body of the carburettor, and a bi-metallic strip is fitted to the jet adjusting (mixture) screw mechanism; that is in order to compensate for the varying fuel densities which result from changes in fuel temperature.



**12.9 Removing the SU HS2 carburettor from the manifold**

## 12 Carburettor - removal and refitting



**Note:** *Observe the precautions in Section 1 before working on any component in the fuel system.*

### SU HS2 and HS4 carburettors

#### Removal

- 1** Disconnect the battery negative lead.
- 2** Remove the air cleaner assembly as described in Section 2.
- 3** Disconnect the distributor vacuum advance pipe from the carburettor (where fitted).
- 4** Slacken the retaining clip screw and withdraw the fuel inlet pipe from the top of the float chamber. Plug the disconnected pipe with a bolt or metal rod of suitable diameter.
- 5** Refer to Sections 3 and 5 and disconnect the accelerator and choke cables from the carburettor linkages.
- 6** Detach the throttle return spring from the bracket on the exhaust manifold clamp. On Cooper S models detach the throttle and throttle linkage return springs from the heat shield. On automatic transmission models detach the governor control rod fork end from the throttle lever.
- 7** Detach the engine breather hose from the carburettor (where fitted).
- 8** Undo and remove the two nuts which secure the carburettor(s) to the inlet manifold studs and recover the spring washers.
- 9** Lift the carburettor carefully off the inlet manifold (**see illustration**). If twin carburettors are being removed, lift off both carburettors together to avoid damaging the linkages that join the two carburettor spindles. These can be removed after the carburettors are lifted clear of the manifold studs.

#### Refitting

- 10** Refitting the carburettor(s) is the reverse sequence to removal, noting the following points:
  - a) *Ensure that all mating surfaces are clean and dry, and use new gaskets.*
  - b) *When refitting twin carburettors, ensure that the linkages joining the two spindles are in position, and that the operating forks are engaged in the slots on the carburettor spindles.*
  - c) *Tighten the carburettor nuts evenly and progressively, to avoid possible distortion of the mounting flange.*
  - d) *Refit the accelerator and choke cables with reference to Sections 3 and 5.*

### SU HIF44 and HIF38 carburettors

#### Removal

- 11** Disconnect the battery negative lead.
- 12** Remove the air cleaner assembly as described in Section 2.
- 13** On Cooper models, remove the carburettor heat shield.



## 4A•10 Fuel system - carburettor engines

**14** On 1992-on models with an open-loop catalytic converter, release the retaining clip and disconnect the charcoal canister hose from the side of the carburettor.

**15** On all models, disconnect the accelerator and choke cables from the carburettor linkages as described in Sections 3 and 5. Free the accelerator outer cable from its bracket, then release the retaining clip and detach the choke cable from the carburettor.

**16** Disconnect the vacuum pipe from the top of carburettor mounting flange.

**17** Release the retaining clip and disconnect the fuel supply hose from the carburettor. Plug the hose end to minimise fuel loss.

**18** Release the retaining clip and disconnect the vent pipe from the float chamber.

**19** Undo the mounting nuts and withdraw the carburettor from the inlet manifold, together with the throttle cable bracket, spacer and gaskets.

### Refitting

**20** Refitting is the reverse sequence to removal, noting the following points.

- Ensure that all mating surfaces are clean and dry, and use new gaskets.
- Tighten the carburettor nuts evenly and progressively, to avoid possible distortion of the mounting flange.
- Refit the accelerator and choke cables with reference to Sections 3 and 5.

### 13 Carburettor (SU HS2 and HS4) - fault diagnosis and overhaul



### Fault diagnosis

**1** If a carburettor fault is suspected, always check first that the ignition timing is correctly set, that the spark plugs are in good condition and correctly gapped, that the throttle and choke cables are correctly adjusted, and that the air cleaner filter element is clean; refer to the relevant Sections of Chapter 1, Chapter 5B or this Chapter. If the engine is running very roughly, first check the valve clearances as described in Chapter 1, then check the compression pressures as described in Chapter 2A.

**2** If careful checking of all the above produces no improvement, the carburettor must be removed for cleaning and overhaul.

**3** Prior to overhaul, check the availability of component parts before starting work; note that most sealing washers, screws and gaskets are available in kits, as are some of the major sub-assemblies.

### Overhaul

**Note:** Observe the precautions in Section 1 before working on any component in the fuel system.

**4** The SU carburettor is a straightforward unit to dismantle and service, but at the same time it is a delicate unit and clumsy handling can cause damage. In particular, it is easy to knock the

finely tapering needle out of true, and the greatest care should be taken to keep all the parts associated with the dashpot in a safe place and scrupulously clean. Prepare a clean and uncluttered working area before starting the dismantling, and have some small containers handy to store the small, easily-lost parts.

**5** Begin by removing the carburettor(s) from the car as described in Section 12. Thoroughly clean the outside of the carburettor in paraffin or a suitable solvent and wipe dry.

**6** Unscrew the piston damper assembly and remove it from the top of the dashpot (**see illustrations**).

**7** Mark the base of the dashpot and carburettor body to ensure that on reassembly the dashpot is refitted in the same position. Now undo and remove the securing screws and lift off the dashpot.

**8** Next lift off the piston spring and then carefully withdraw the piston and needle assembly from the carburettor body. Undo the small sunken retaining screw in the side of the piston and lift out the needle. On later types equipped with a spring-loaded needle, recover the guide collar from the needle, and the spring from the piston, after removing the needle assembly.

**9** Undo and remove the three retaining screws and lift off the float chamber cover and gasket. The float may be released from the cover by gently tapping out the float hinge pin. The fuel cut-off needle valve can now be withdrawn from its seat in the cover and the needle seat unscrewed if required.

**10** Unscrew the union nut securing the nylon fuel pipe to the base of the float chamber and carefully withdraw the pipe. Note the position of the gland, ferrule and rubber sealing washer on the end of the pipe and make sure that the rubber washer has not been left behind in the float chamber as the pipe is withdrawn. If so, hook it out carefully with a small screwdriver.

**11** If there is a tamperproof cap in position around the jet adjusting nut at the base of the carburettor, prise it apart with a screwdriver and discard it.

**12** Release the jet link lever return spring from the cam lever on the linkage.

**13** Undo and remove the small screw or release the clip that secures the jet link arm to the jet. Move the jet link arm to one side and withdraw the jet assembly, complete with fuel pipe from the jet housing.

**14** It is not normally necessary to carry out any further dismantling of the SU carburettor. However, if the throttle spindle, jet housing, or float chamber are worn, damaged, or in any way suspect, the remainder of the carburettor may be dismantled as described below.

**15** Bend back the small tab washer and then undo and remove the nut securing the throttle lever to the spindle. Lift off the lever.

**16** Straighten the splayed ends of the two throttle disc retaining screws and then mark the position of the disc in relation to the

spindle. Undo and remove the two screws, turn the disc to the fully open position and slide the disc out of the slot in the spindle. Note that new throttle disc retaining screws must be used when reassembling.

**17** The spindle can now be removed from the carburettor body.

**18** To remove the choke linkage undo the retaining pivot bolt and lift it off complete with linkage.

**19** To dismantle the jet housing, first undo and remove the jet adjusting nut and lock spring. Next undo and remove the jet bearing locknut and withdraw the bearing.

**20** The float chamber can be lifted off after unscrewing the retaining through-bolt. Recover the float chamber spacer, where fitted.

**21** The carburettor is now completely dismantled with the exception of the piston lifting pin (omitted on later carburettors). The pin may be removed by prising off the small upper retaining circlip and lifting off the pin and spring.

**22** Thoroughly clean all the carburettor components and dry thoroughly.

**23** Carefully examine the throttle spindle and throttle disc for wear or distortion. If excessive wear is apparent on the spindle or spindle bushes in the carburettor body, air will enter the carburettor, altering the mixture strength and causing uneven running. The throttle spindle is obtainable separately, but if the bushes are worn, a complete carburettor body will normally have to be obtained.

**24** Closely inspect the carburettor needle. If this has not been running centrally in the jet orifice then the needle will have a tiny ridge worn on it. If a ridge can be seen then the needle must be renewed. SU carburettor needles are made to very fine tolerances and should a ridge be apparent no attempt should be made to rub the ridge down with emery paper.

**25** If the needle is worn, it is likely that the jet will also be worn. If this is the case, also renew the jet. Also inspect the outside of the jet head where it bears against the jet bearing. Wear can take place here due to the action of the choke control moving the jet up and down in the jet bearing.

**26** The most critical components of the SU carburettor are the piston and dashpot assembly. Free movement of the piston in the dashpot is essential for the carburettor to function satisfactorily. The piston is machined to very fine tolerances so that it will not touch the side of the dashpot or carburettor body. If wear takes place on the centre guide tube or if deposits build up on the internal surfaces of the dashpot, the piston will come into contact with the side of the dashpot and will bind. This condition is known as piston sticking. If this condition cannot be improved after cleaning the inside of the dashpot and the piston with metal polish (harsh abrasives must not be used), then the piston and dashpot will have to be renewed. These two components are



**13.6a Exploded view of the SU HS2 carburettor**

- 1 Body
- 2 Piston lifting pin
- 3 Spring
- 4 Circlip
- 5 Dashpot and piston assembly
- 6 Needle locking screw
- 7 Piston damper assembly
- 8 Washer for damper cap
- 9 Piston spring
- 10 Screw
- 11 Jet assembly
- 12 Jet bearing
- 13 Washer
- 14 Locknut for jet bearing
- 15 Lock spring
- 16 Jet adjusting nut
- 17 Jet needle
- 18 Float chamber body
- 19 Bolt
- 20 Float and lever assembly
- 21 Lever hinge pin
- 22 Float chamber lid assembly
- 23 Gasket
- 24 Needle and seat assembly
- 25 Screw
- 26 Spring washer
- 27 Baffle
- 28 Throttle spindle
- 29 Throttle disc
- 30 Screw
- 31 Throttle lever
- 32 Fast idle adjusting screw
- 33 Spring for adjusting screw
- 34 Throttle spindle nut
- 35 Tab washer
- 36 Idle speed adjusting screw
- 37 Spring for adjusting screw
- 38 Cam lever
- 39 Washer
- 40 Cam lever spring
- 41 Cam lever pivot bolt
- 42 Pivot bolt tube
- 43 Spring washer
- 44 Pick-up lever assembly
- 45 Jet link
- 46 Jet link retaining clip
- 47 Jet link securing screw
- 48 Bush
- 49 Spring for pick-up lever

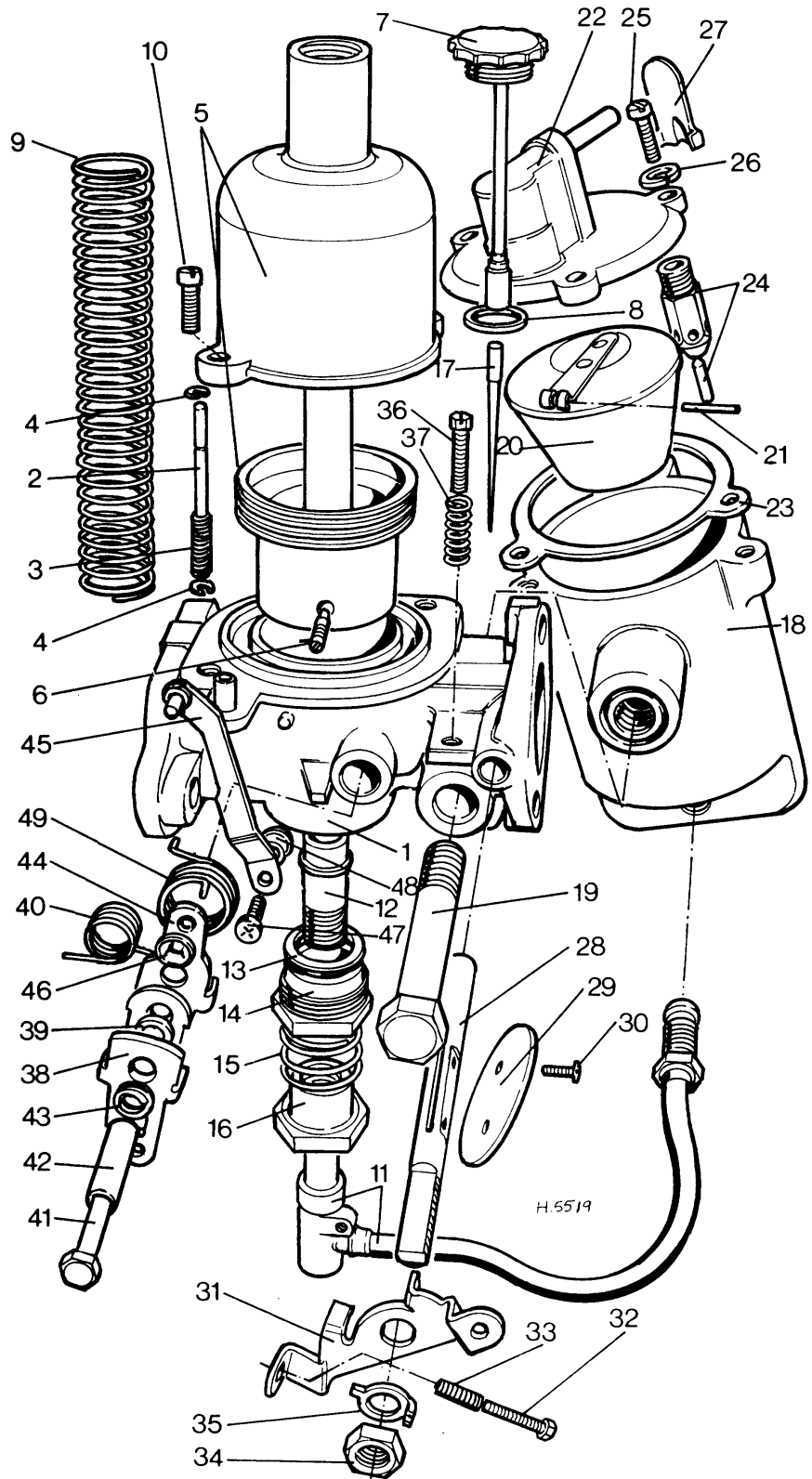

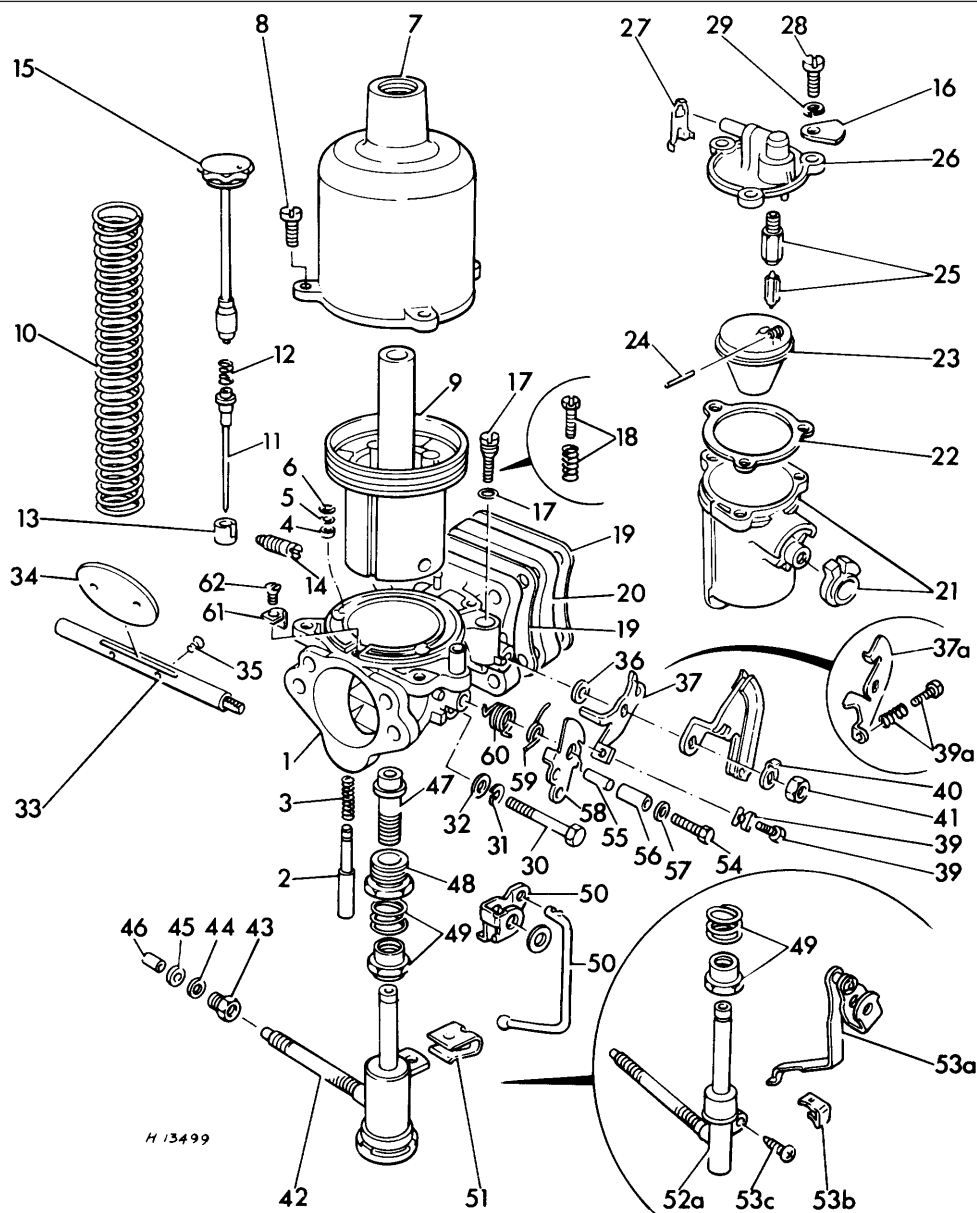

H 13499

13.6b Exploded view of the SU HS4 carburettor

- |   |  |                                     |                                    |
|---|--|-------------------------------------|------------------------------------|
| 1 Body                                    | 18 Idle speed adjusting screw and spring | 35 Screw                            | 50 Rod link and pick-up lever      |
| 2 Piston lifting pin                      | 19 Gaskets                               | 36 Washer                           | 51 Spring clip                     |
| 3 Spring                                  | 20 Insulator block                       | 37 Throttle return lever*           | 52a Jet assembly                   |
| 4 Sealing washer                          | 21 Float chamber and spacer              | 37a Throttle return lever           | 53a Pick-up lever non-Capstat type |
| 5 Plain washer                            | 22 Gasket                                | 38 Progressive throttle (snail cam) | 53b Link                           |
| 6 Circlip                                 | 23 Float                                 | 39 Fast idle screw*                 | 53c Screw                          |
| 7 Dashpot                                 | 24 Hinge pin                             | 39a Fast idle screw and spring      | 54 Pivot bolt                      |
| 8 Screw                                   | 25 Needle and seat                       | 40 Lockwasher                       | 55 Pivot bolt tube – inner         |
| 9 Piston                                  | 26 Float chamber cover                   | 41 Nut                              | 56 Pivot bolt tube – outer         |
| 10 Spring                                 | 27 Baffle plate                          | 42 Jet assembly – Capstat type      | 57 Distance washer                 |
| 11 Needle                                 | 28 Screw                                 | 43 Sleeve nut                       | 58 Cam lever                       |
| 12 Needle tension spring                  | 29 Spring washer                         | 44 Washer                           | 59 Cam lever spring                |
| 13 Needle guide collar                    | 30 Bolt                                  | 45 Gland                            | 60 Pick-up lever spring            |
| 14 Locking screw                          | 31 Spring washer                         | 46 Ferrule                          | 61 Piston guide                    |
| 15 Piston damper                          | 32 Plain washer                          | 47 Jet bearing                      | 62 Screw                           |
| 16 Identification tag                     | 33 Throttle spindle                      | 48 Jet locating nut                 |                                    |
| 17 Idle speed adjusting screw and O-ring* | 34 Throttle disc                         | 49 Jet adjustment nut and spring    |                                    |

\*Used with sealed adjustment carburettors



13.35a Refit the fixed jet needle to the piston . . .

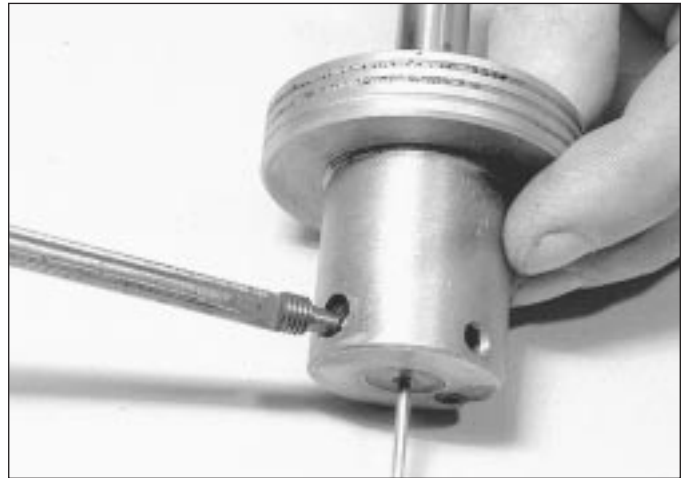

13.35b . . . and secure with the retaining screw

only obtainable as matched pairs and cannot be interchanged. The piston and dashpot assembly are in a satisfactory condition if the piston, having been pushed right to the top of the dashpot, will drop under its own weight without any trace of binding.

**27** Examine the float chamber needle valve and seat next. After high mileage, it is quite likely that a ridge will have formed on the face of the needle. This could prevent the needle valve from shutting off the fuel supply and cause flooding of the carburettor. This is quite a common occurrence on SU carburettors and unless the needle and seat appear to be in perfect condition, they should both be renewed.

**28** Finally, check the condition of the float. If any signs of cracking or distortion are evident, which may allow fuel to enter, renew the float.

**29** If the carburettor has been completely dismantled, begin reassembly by refitting the piston lifting pin and spring into the carburettor body and then refit the retaining circlip.

**30** Place the float chamber in position and secure it in place, with the long retaining bolt inserted through the side of the carburettor body.

**31** Refit the jet bearing, washer and locknut finger-tight only. Do not refit the lock spring or jet adjusting nut at this stage.

**32** Refit the choke linkage and retaining pivot bolt.

**33** Insert the throttle spindle into the carburettor body with the countersunk holes in the spindle facing outwards. Insert the throttle disc into the spindle, noting the assembly markings made during dismantling. Secure the disc to the spindle using new retaining screws, but do not tighten them. Snap the spindle open and shut to centralise the disc and make sure that the disc does not bind in the carburettor bore in any position. If necessary reposition the disc slightly. Now tighten the screws and spread their ends enough to prevent them from turning.

**34** Slide the spacing washer and throttle lever onto the spindle, followed by the tab washer and retaining nut. Tighten the nut and bend over the tab washer.

**35** On carburettors with a fixed jet needle, insert the needle into the piston, ensuring that the shoulder on the shank of the needle is flush with the underside of the piston. Refit and fully tighten the sunken retaining screw (see illustrations).

**36** On carburettors equipped with a spring-loaded needle, fit the spring and guide collar to the needle and insert this assembly into the piston. Position the guide collar so that it is flush with the underside of the piston and position the needle so that the small etch mark is between the two piston transfer holes. Secure the assembly with the sunken retaining screw (see illustration).

**37** If the jet housing has been removed, it will now be necessary to centralise the jet as follows.

**38** With the jet bearing, washer and locknut in position as described in paragraph 31, refit

the jet adjusting nut, without the lock spring, and screw it up as far as it will go. Now slide the jet assembly into the jet housing.

**39** Carefully refit the piston and needle assembly to the carburettor body, followed by the spring and dashpot. Align the previously made marks on the dashpot and carburettor body and then refit the securing screws.

**40** Slacken the jet bearing locknut and hold the piston down using a pencil inserted through the damper opening. Now tighten the jet bearing locknut.

**41** Lift the piston and allow it to fall under its own weight. A definite metallic click should be heard, as the piston falls and contacts the bridge in the carburettor body.

**42** Now fully lower the adjusting nut and note whether the piston still falls freely. If not, slacken the jet bearing locknut and repeat the centring procedure. It may be necessary to carry out the centring operation several times, until the piston will fall freely with the adjusting nut at the top and bottom of its travel.

**43** With the jet correctly centralised, slide out the jet assembly and unscrew the adjusting nut. Now place the lock spring in position and refit the adjusting nut and jet assembly. Secure the jet link arm to the jet with the screw or retaining clip.

**44** The flexible jet fuel supply tube can now be refitted to the base of the float chamber. Ensure that the small rubber sealing washer, nut and gland are in position on the tube and that there is at least 5.0 mm of pipe protruding through the washer. Push the tube into the float chamber and tighten the union nut.

**45** Refit the fuel cut-off needle and seat to the float chamber cover. Place the float in position and tap in the float hinge pin until equal amounts of the pin are protruding either side of the mounting lugs.

**46** On early carburettors equipped with a brass float, invert the float chamber cover so that the needle valve is closed. It should now just be possible to place a  $\frac{3}{16}$  inch (8.0 mm) diameter bar parallel to the float hinge pin and

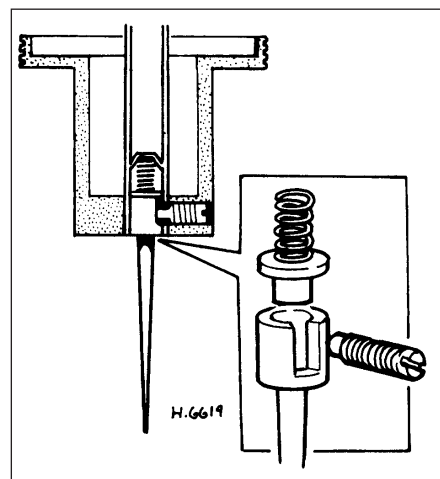

13.36 The spring-loaded needle assembly fitted to the later SU HS4 carburettors

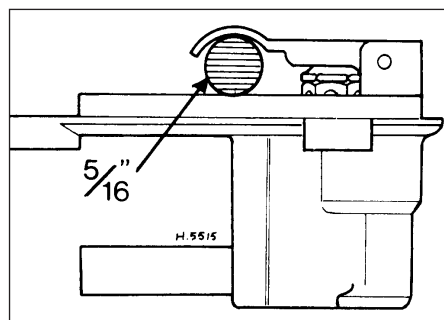

**13.46 Method of setting the correct clearance of the float lever - early carburettors**

in the centre of the float chamber cover, without fouling the float. If the bar lifts the float or if the float stands clear of the bar, bend the float lever very slightly until the clearance is correct (see illustration).

**47** Later carburettors fitted with plastic floats incorporate either a plain steel needle or a spring-loaded needle enclosed in a plastic sheath. The adjustment procedure for the plain steel needle type is the same as described in paragraph 46. Float level adjustment for spring-loaded needles is as follows.

**48** Invert the float chamber cover so that the needle valve is closed but the spring is not compressed. The gap between the float and the flange on the float chamber cover, at the centre of the cover, should be between 3.18 mm and 4.76 mm (see illustration). If the gap is incorrect, bend the float lever slightly until the specified gap is obtained. In the case of floats having a moulded plastic hinge, increase or decrease the washer thickness under the needle seat to achieve the desired float level height.

**49** Place a new gasket in position on the float chamber, refit the cover and secure it with the three retaining screws.

**50** Fill the carburettor piston damper with the correct grade of oil, until the level is 13.0 mm

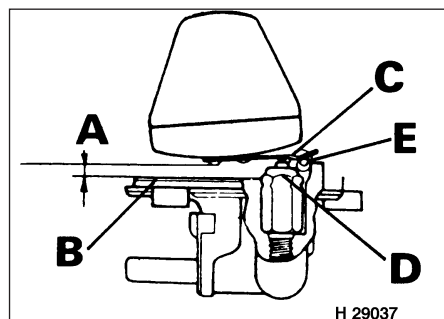

**13.48 Method of setting the correct clearance of the float lever - later carburettors**

A 3.18 to 4.76 mm

B Machined lip

C Float lever adjustment point

D Float needle and seat assembly

E Lever hinge pin

above the top of the hollow piston rod. Now refit the damper plunger.

**51** To obtain an initial jet setting and to allow the engine to be started, screw the jet adjusting nut up until the jet is flush with the bridge in the carburettor body. Now screw the nut down two complete turns on non-sealed carburettors and three complete turns on sealed units. **Note:** The sealed type carburettors are identified by the throttle adjusting screw which is recessed within the carburettor body.

**52** The carburettor can now be refitted to the car as described in Section 12 and the idle speed and mixture adjustments carried out as described in Section 15.

## 14 Carburettor (SU HIF44 and HIF38) - fault diagnosis and overhaul



### Fault diagnosis

**1** Refer to Section 13.

### Overhaul

#### SU HIF44 carburettor

**2** Remove the carburettor from the car as described in Section 12, then clean the exterior surfaces thoroughly and wipe dry.

**3** Mark the float chamber cover in relation to the carburettor body. Remove the screws, and withdraw the cover and sealing ring (see illustration).

**4** Unscrew and remove the mixture screw and spring, and withdraw the seal.

**5** Unscrew the jet retaining screw, and remove the spring.

**6** Withdraw the jet and bi-metal lever assembly. Disengage the lever from the jet.

**7** Unscrew and remove the float pivot and seal.

**8** Withdraw the float and the needle valve.

**9** Unscrew and remove the needle valve seat.

**10** Unscrew and remove the piston damper, and drain the oil.

**11** Mark the dashpot in relation to the carburettor body. Remove the screws and withdraw the dashpot together with the piston.

**12** Prise the clip from the top of the piston rod, then withdraw the piston and spring from the dashpot.

**13** Unscrew the needle retaining grub screw. Remove the needle, guide and spring from the piston.

**14** From underneath the main body, unscrew the jet bearing nut and withdraw the bearing.

**15** Note how the spring is attached to the fast idle cam lever, then bend back the locktabs, unscrew the nut and remove the washer.

**16** Hold the return spring against the main body, and use a screwdriver to prise the cam lever from the end of the cold start spindle. Remove the spring.

**17** Remove the end cover and spindle seat.

**18** Remove the two screws and withdraw the retaining plate, cold start body and gasket.

**19** Remove the O-ring from the end of the cold start spindle, and withdraw the spindle from the main body. Remove the cold start seal.

**20** Dismantling of the throttle spindle is not recommended, unless the components are damaged or excessively worn. If they are, first note how the return spring is attached to the throttle lever.

**21** Mark the throttle valve in relation to the spindle and main body.

**22** Remove the throttle valve screws while supporting the spindle with a block of wood if necessary.

**23** Open the throttle and withdraw the valve disc.

**24** Remove any burrs from the spindle screw holes with a fine file.

**25** Bend back the locktabs and unscrew the spindle nut. Remove the lockwasher, plain washer, throttle lever, and return spring.

**26** From the opposite end of the spindle, loosen the nut and bolt, and remove the throttle damper lever.

**27** Check the threaded end of the spindle and main body in relation to each other, then withdraw the spindle. Remove the two seals.

**28** Clean all the components dry thoroughly. Examine each item for damage and excessive wear. In particular, check the throttle spindle and bearings for wear. If excessive, renewal of the spindle may be sufficient, but if the bearings are worn, it may be necessary to renew the complete carburettor, as new bearings are not always available. Check the needle valve and seating for excessive ridging. Examine the main body for cracks, and for security of the brass fittings and piston key. Check the tapered needle, jet and jet bearing for wear. Shake the float, and listen for any trapped fuel which may have entered through a small crack or fracture. Renew the components as necessary, and obtain a complete set of gaskets and seals, and two new throttle valve screws if necessary.

**29** Clean the inside of the dashpot and the periphery of the piston with methylated spirit. Do not use any form of abrasive. Lubricate the piston rod with engine oil, and insert it into the dashpot. Hold the two components horizontal, and spin the piston in several positions. The piston must spin freely, without touching the sides of the dashpot.

**30** Commence reassembly by fitting the throttle spindle and two seals to the main body. The seals must be slightly recessed in their housings.

**31** Locate the return spring and throttle lever on the end of the spindle, and fit the plain washer, lockwasher, and nut. Tighten the nut while holding the lever, and bend over the locktabs to lock.

**32** Engage the return spring with the throttle lever and main body, and tension the spring.



14.3 Exploded view of the SU HIF carburettor

- 1 Piston damper
- 2 Dashpot
- 3 Piston spring and clip
- 4 Piston
- 5 Needle retaining screw
- 6 Spring
- 7 Jet needle
- 8 Guide
- 9 Lifting pin
- 10 Lifting pin and circlip
- 11 Spindle seal
- 12 Throttle spindle
- 13 Throttle valve and screw
- 14 Return springs
- 15 Throttle lever and progressive throttle cam
- 16 Fast idle adjustment screw
- 17 Idle speed adjustment screw
- 18 Spindle nuts and tab washers
- 19 Return spring lever
- 20 Mixture control lever and fast idle cam
- 21 Return spring
- 22 Dust cap
- 23 Seal
- 24 Retaining plate
- 25 Cold start body
- 26 O-ring
- 27 Cold start spindle
- 28 Cold start seal
- 29 Main body
- 30 Jet bearing
- 31 Jet bearing nut
- 32 Jet assembly
- 33 Bi-metallic jet lever
- 34 Jet (mixture) adjusting screw and seal
- 35 Jet retaining screw and spring
- 36 Float
- 37 Float pivot and seal
- 38 Needle valve
- 39 Needle valve seat
- 40 Fuel strainer
- 41 Float chamber cover
- 42 Cover seal
- 43 Screw and spring washer

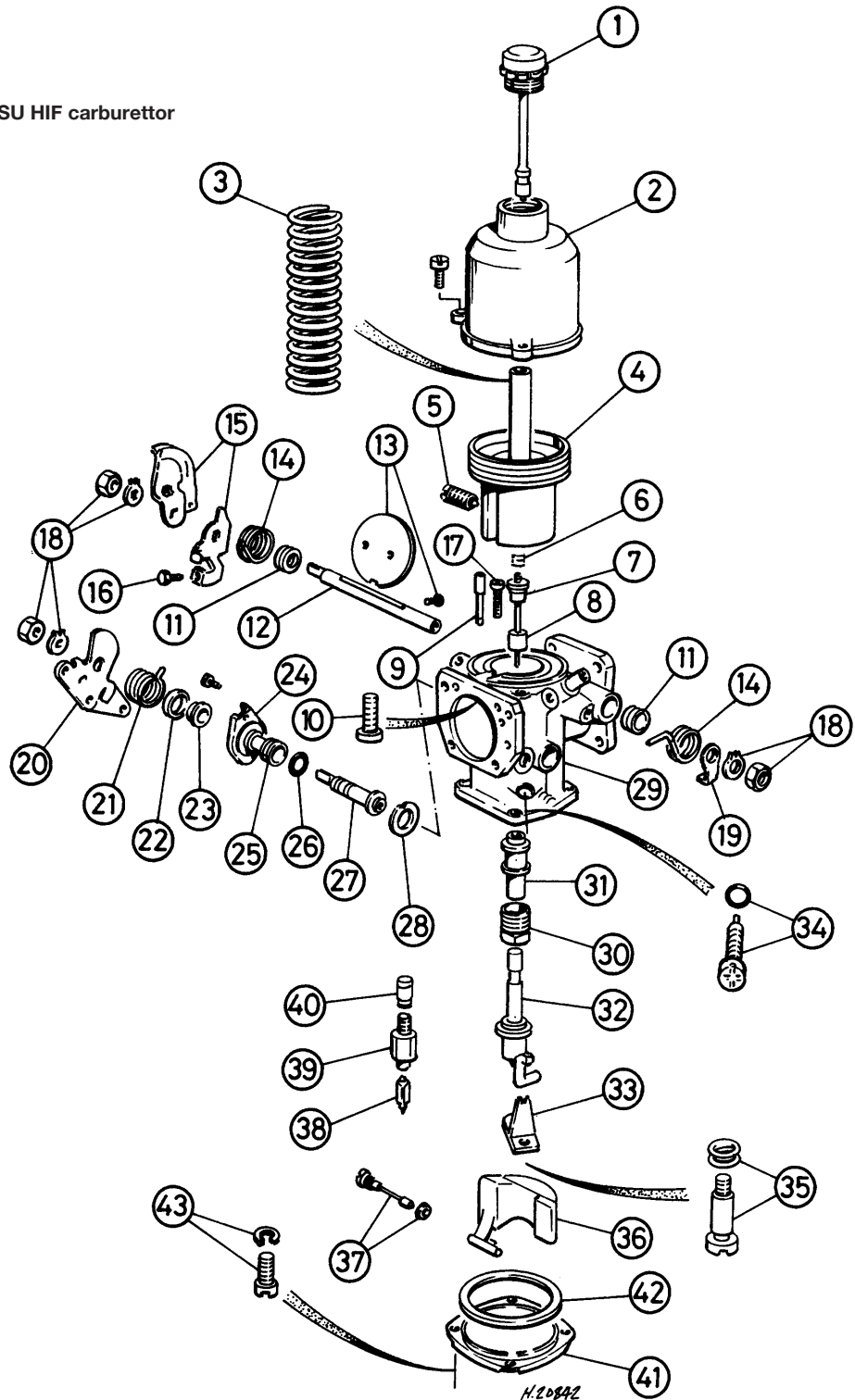

**33** Fit the throttle valve disc to the spindle in its original position, and insert the new screws, tightening them loosely (coat the threads with thread-locking fluid).

**34** Open and close the throttle several times to settle the disc, then tighten the screws while supporting the spindle on a block of wood. Using a small chisel, spread the ends of the screws to lock them.

**35** Locate the throttle damper lever loosely on the end of the spindle.

**36** Locate the cold start seal in the main body with the cut-out uppermost.

**37** Insert the cold start spindle (hole uppermost), and fit the O-ring.

**38** Fit the cold start body with the cut-out uppermost, and the retaining plate with the slotted flange facing the throttle spindle. Use a new gasket, then insert and tighten the retaining screws.

**39** Fit the spindle seat and end cover, followed by the spring, cam lever, lockwasher, and nut. Make sure that the spring is correctly engaged, then tighten the nut and bend over the locktabs to lock.

**40** Insert the jet bearing and nut, and tighten the nut.

**41** Connect the bi-metal lever with the fuel jet, making sure that the jet head moves freely in the cut-out.

**42** Insert the mixture screw and seal into the main body. Fit the jet to the bearing, and at the same time engage the slot in the bi-metal lever with the small diameter of the mixture screw.

**43** Insert the jet retaining screw with the spring, and tighten the screw.

**44** Adjust the mixture screw so that the top of the jet is flush with the venturi bridge.

**45** Insert and tighten the needle valve seat, and with the carburettor inverted, insert the needle valve.

**46** Position the float, then insert the pivot and seal through the body and float, and tighten.

**47** To check the float level adjustment, hold the carburettor inverted with the float keeping the needle valve shut. Using a straight edge and feeler blade, check that the centre portion of the float is  $1.0 \pm 0.5$  mm below the surface of the float chamber face (see illustration). If not, bend the tab which contacts the needle valve as necessary.

**48** Fit the float chamber cover in its original position, together with a new sealing ring. Tighten the screws in diagonal sequence.

**49** Insert the spring, needle, and guide into the piston with the guide etch marks facing the dashpot transfer holes, and with the bottom face of the guide flush with the bottom face of the piston (see illustration 13.36).

**50** Insert and tighten the guide retaining grub screw.

**51** Lower the piston and needle assembly into the main body, at the same time engaging the slot with the piston key.

**52** Locate the spring over the piston rod.

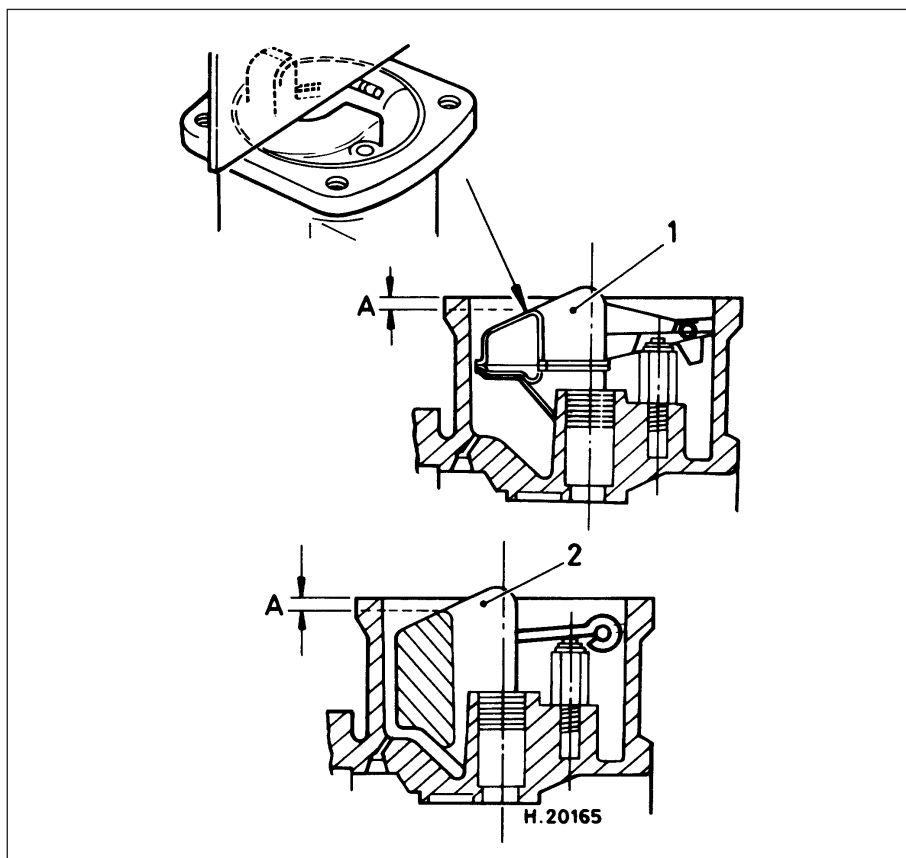

14.47 SU HIF carburettor float level adjustment "A"

1 Type 1 float

2 Type 2 float

$A = 1.0 \pm 0.5$  mm

**53** Hold the dashpot directly over the piston with its location mark aligned with the mark on the body, then lower it over the spring and piston rod. It is important not to tension the spring by twisting the dashpot.

**54** Insert and tighten the dashpot retaining screws. Lift the piston with a finger, then release it and check that it returns to the venturi bridge without any assistance. If not, it may be necessary to loosen the retaining screws and slightly reposition the dashpot.

**55** Hold the piston fully up, then fit the clip to the top of the piston rod.

**56** Pour the specified type of oil into the top of the dashpot until the level is 13.0 mm above the top of the hollow piston rod. Refit and tighten the piston damper.

#### SU HIF38 carburettor

**57** At the time of writing, no specific information on the HIF38 carburettor fitted to the 1992-on 1275 cc models was available. However the carburettor is really only a slightly smaller version of HIF44 (38 mm bore instead of 44 mm) it is otherwise identical. Therefore, the carburettor can be overhauled using the information given above, noting that it will be necessary to refer to a Rover dealer for correct float height measurements; those given in paragraph 47 are only applicable to the HIF44 carburettor.

#### 15 Carburettor (SU HS2 and HS4) - idle speed and mixture adjustment



#### Preliminary information

**1** Three adjustments are possible on the SU carburettor. These are the engine idling speed, fast idling speed and mixture strength. The mixture strength is particularly important as the initial setting, carried out with the engine idling, determines the mixture strength throughout the entire engine speed range. A good indication as to whether carburettor adjustment is necessary can be gained by checking the colour of the exhaust tailpipe and listening to the note of the exhaust at idling speed. If the tailpipe is black and the engine appears to be hunting, it is quite likely that the mixture is too rich. If the exhaust is light grey or white in appearance, accompanied by a rhythmic puffing sound, this would indicate a weak mixture. Ideally, the exhaust should be a medium grey colour and emit a steady even drone. The colour of the spark plugs will also give a good indication as to the mixture strength and general engine condition (see Chapter 1). These checks should only be carried out after

a good run of about 5 to 10 miles. Idling in city traffic and stop/start motoring is bound to cause excessively dark exhaust pipe and spark plug deposits.

**2** Before carrying out any adjustments to the carburettor, ensure that the ignition system is in good condition, that the spark plugs, contact breaker points and ignition timing settings are correct, and that the engine is at normal operating temperature. Check also that the carburettor dashpot oil damper is topped up to the correct level with the specified grade of oil.

**3** Depending on year of manufacture either a sealed or non-sealed carburettor may be fitted. Early models are equipped with the non-sealed type, identified by the throttle and fast idle adjusting screws which are clearly visible and retained by a tension spring or locknut. On the sealed carburettors the throttle adjusting screw is located in a recessed hole in the carburettor body and may be covered by a small circular metal cap.

**4** Carburettor adjustment is carried out as follows, according to type.

**Adjustment**

**Single carburettor installations - non-sealed type**

**5** Remove the air cleaner assembly as described in Section 2.

**6** Connect a tachometer to the engine (if one is not already fitted to the car), following the manufacturer's instructions. If your ears can attune to slight changes in engine rpm or to alterations of the exhaust note, then it is possible to carry out the adjustments without the use of a tachometer.

**7** Set the engine idling speed by turning the throttle adjusting screw until the specified idling speed is obtained (**see illustrations**).

**Note:** *If the throttle adjusting screw is secured by a locknut, slacken the locknut before turning the adjusting screw and leave it slackened until all the carburettor adjustments have been completed.*

**8** To check the mixture strength, press the piston lifting pin on the side of the carburettor upwards, against light spring resistance, until it comes into contact with the piston. Now press it up a further 1.0 mm and listen to the engine speed. This will indicate one of the following:

- a) *If the speed of the engine increases appreciably, the mixture is too rich.*
- b) *If the engine speed immediately decreases or the engine stalls, the mixture is too weak.*
- c) *If the engine speed remains constant or increases very slightly, the mixture is correct.*

**9** To enrich the mixture, rotate the jet adjusting nut located at the base of the carburettor in a clockwise direction as viewed from above, ie downward. To weaken the mixture, rotate the jet adjusting nut anti-clockwise as viewed from above, ie upward, while at the same time pushing the jet assembly upwards against the nut. When altering the mixture strength, only turn the nut one flat at a time and check the mixture with the lifting pin each time.

**10** It is quite likely that there will be a slight increase or decrease in engine rpm, after the mixture adjustment has been made. This should be corrected by turning the throttle adjusting screw, until the specified idling speed is again obtained.

**11** With the engine idling at the specified speed and the mixture correctly adjusted, check the fast idle adjustment as follows.

**12** Rotate the choke linkage on the side of the carburettor, to the point where the linkage just starts to lower the jet. Hold the linkage in this position and rotate the fast idle adjustment screw, until the specified engine fast idle speed is obtained.

**13** When all adjustments are complete, disconnect the tachometer, refit the air cleaner and road test the car, carrying out any small adjustments that may be necessary, on the road.

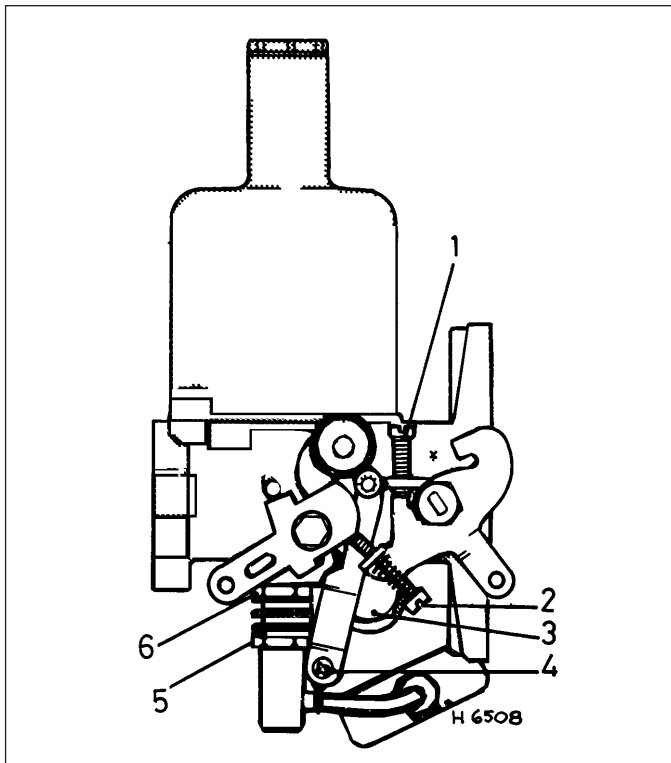

**15.7a Carburettor adjustment points – SU HS2**

- |                             |                           |
|-----------------------------|---------------------------|
| 1 Throttle adjusting screw  | 4 Jet link securing screw |
| 2 Fast idle adjusting screw | 5 Jet adjusting nut       |
| 3 Float chamber bolt        | 6 Jet locknut             |

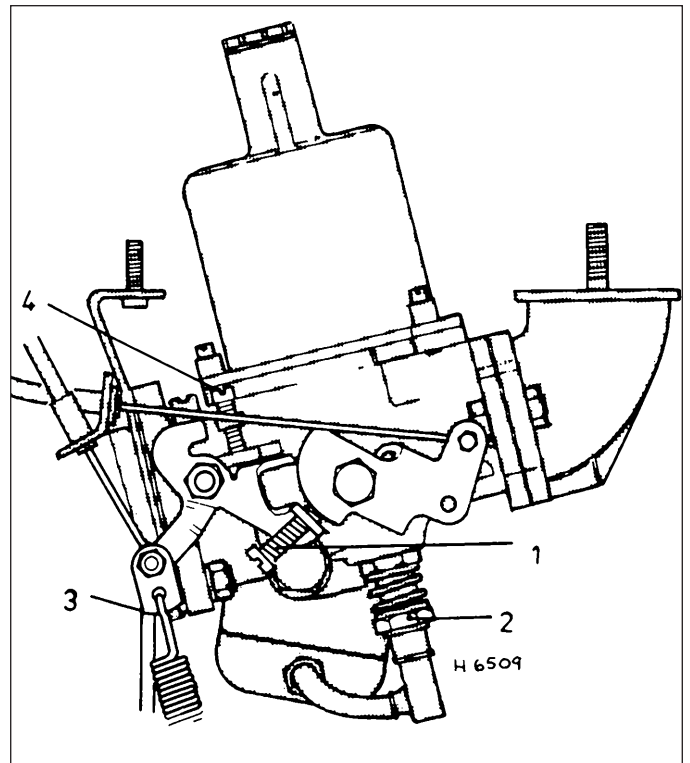

**15.7b Carburettor adjustment points – SU HS4**

- |                             |   |
|-----------------------------|---|
| 1 Fast idle adjusting screw | 3 Governor control rod (automatic transmission) |
| 2 Jet adjusting nut         | 4 Throttle adjusting screw                      |

**Single carburettor installations - sealed type without open-loop catalytic converter**

14 Remove the air cleaner assembly as described in Section 2.

15 If the tamperproof seals are still in position over the throttle adjusting screw and mixture adjusting nut, remove and discard them (see illustration). The seal over the throttle adjusting screw can be hooked out of the recess using a small screwdriver. The seal on the jet adjusting nut can be removed by prising it open with a screwdriver and then lifting away the two halves.

16 Connect a tachometer to the engine (if one is not already fitted to the car), following the manufacturer's instructions. If your ears can attune to slight changes in engine rpm or to alterations of the exhaust note, then it is possible to carry out the adjustments without the use of a tachometer.

17 Set the engine idling speed, by turning the throttle adjusting screw until the specified idling speed is obtained.

18 Turn the jet adjusting nut located at the base of the carburettor in a clockwise or anti-clockwise direction, one flat at a time, until the

fastest possible engine speed consistent with even running is obtained. Turning the nut clockwise as viewed from above, ie downward, enriches the mixture. Turning the nut anti-clockwise as viewed from above, ie upward, weakens the mixture.

19 It is quite likely that there will be a slight increase or decrease in engine rpm after the mixture adjustment has been made. This should be corrected by turning the throttle adjusting screw until the specified idling speed is again obtained.

20 The remainder of the adjustment procedure is the same as described previously for non-sealed carburettors in paragraphs 11 to 13.

**Single carburettor installations - sealed type with open-loop catalytic converter**

21 On 1992-on 998 cc models equipped with an open-loop catalytic converter, the idle speed and mixture adjustments can be carried out as described previously in paragraphs 14 to 20, but using an exhaust gas analyser to check the CO content of the exhaust gas.

22 The gas analyser should be used in accordance with the maker's instructions and connected to the take-off point at the top of the exhaust system front pipe. To do this, it will first be necessary to jack up the front of the car and support it on axle stands.

23 Unscrew the threaded plug from the front pipe, and screw the gas sampling pipe adapter into the threaded hole; the adapter can be obtained from a Rover dealer. The gas analyser should then be connected to the end of the sampling pipe.

24 On completion, unscrew the sampling pipe, then refit the threaded plug and tighten it securely.

**Twin carburettor installations**

25 Before adjusting the mixture strength on models fitted with twin carburettors, it is necessary to ensure that the volume of air passing through each carburettor is the same. This is done as follows.

26 Remove the air cleaner assembly as described in Section 2.

27 Slacken the two clamp bolts on the throttle spindle operating arms and the two clamp bolts on the choke spindle operating arms (see illustration).

28 Start the engine without depressing the accelerator and allow it to idle.

29 Using a proprietary balancing meter, in accordance with the manufacturer's instructions, balance the carburettors by altering the throttle adjusting screws until the airflow through both carburettors is the same.

30 Alternatively, use a length of small bore tubing, such as heater hose, approximately 457 mm long, to compare the intensity of the inlet hiss on both carburettors. Turn the throttle adjusting screws until the hiss sounds the same in both carburettors. It should be noted that this method is not really recommended, as it tends to be somewhat less accurate, and certainly more difficult, than using a balancing meter.

31 When the two carburettors are balanced, bring the engine idling speed back to the specified rpm by turning both throttle adjusting screws by equal amounts.

32 Now tighten the two clamp bolts, on the throttle spindle operating arms, making sure

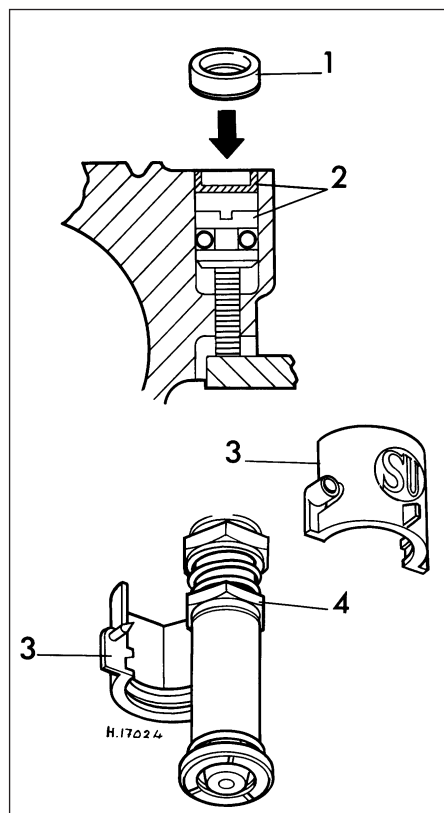

15.15 The tamperproof caps fitted to the later type sealed carburettors

- 1 Throttle adjusting screw cap
- 2 Throttle adjusting screw showing cap in position
- 3 Jet adjusting nut seals
- 4 Jet adjusting nut

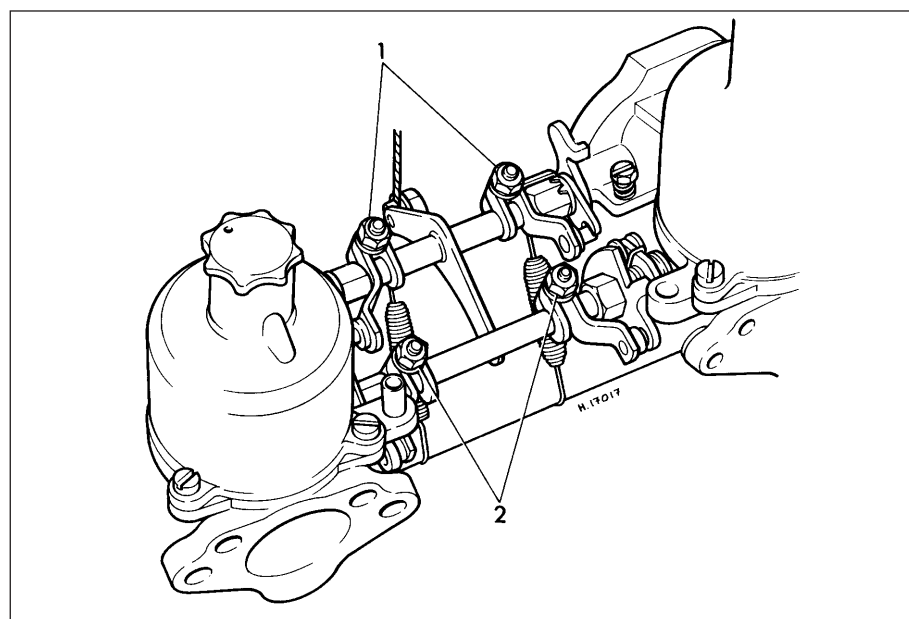

15.27 Throttle and choke linkage - Cooper S models

- 1 Throttle spindle operating arms
- 2 Choke spindle operating arms



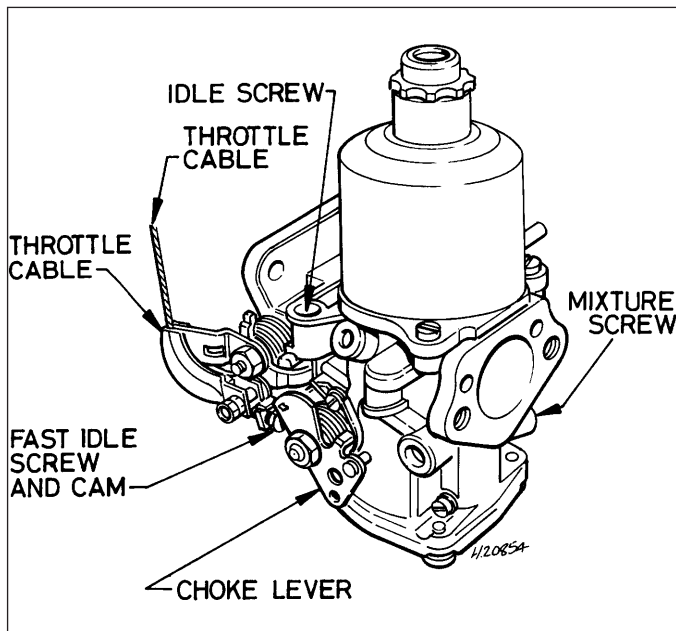

16.4 Gas sampling pipe location (arrowed) on 1990-on Cooper models

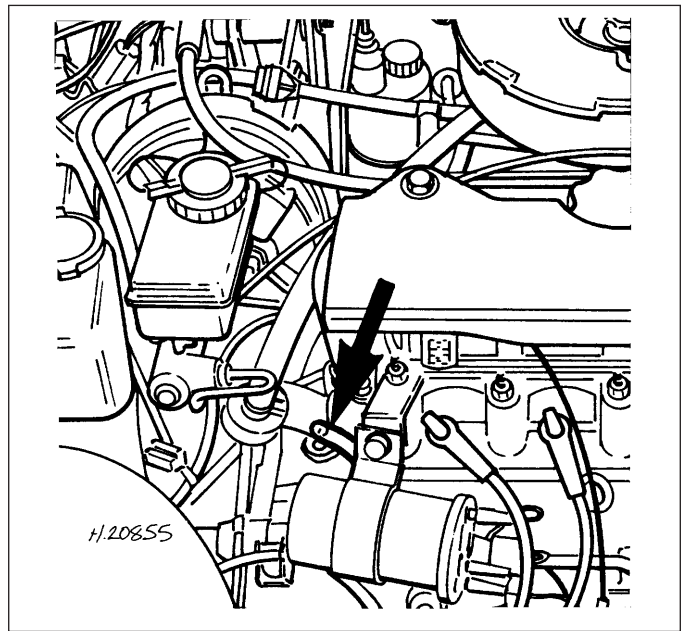

16.7 Adjusting location points on the SU HIF

that a slight clearance exists between the peg and the lower edge of the fork. Ensure also that the arms are positioned in such a way that both carburettor throttles open at the same time, when the accelerator pedal is depressed. If necessary, reposition one of the arms slightly to achieve this condition.

**33** Now adjust the mixture strength for each carburettor using the procedure described in paragraphs 8 and 9.

**34** If the idling speed requires adjustment after setting the mixture, turn both throttle adjusting screws by an equal amount in the desired direction.

**35** The choke spindle operating arms can now be positioned and tightened using the method described previously for the throttle operating arms.

**36** Finally, adjust the fast idle speed as follows.

**37** Pull out the choke control knob or operate the linkage by hand, until the linkage just starts to lower the jets. Hold the linkage in this position and turn the fast idle adjusting screws, on both carburettors, until the specified fast idle speed is obtained and both carburettors are passing the same volume of air.

**38** Adjustment of the carburettors is now complete. Refit the air cleaner and carry out a thorough road test.

*instruments are not available, the car should be taken to a Rover dealer for the work to be carried out.*

### Preliminary information

**1** Refer to Section 15, paragraphs 1 and 2, then check the following items:

- a) The crankcase ventilation hoses are secure and in good condition (Chapter 4C).
- b) The choke cable is correctly adjusted (Section 5).
- c) The accelerator cable is correctly adjusted (Section 3).
- d) The fast idle screw is correctly adjusted, so that there is clearance between the screw and the cam with the choke control off.

**2** Run the engine to normal operating temperature. Driving the car on the road for approximately 4 miles will achieve this.

**3** The adjustments should be completed within two minutes of the engine reaching normal temperature, *before* the electric cooling fan operates. If the adjustments are not completed within the two minutes or if the cooling fan operates, wait for the fan to switch off, then increase the engine speed to 2000 rpm for approximately 30 seconds. The adjustments can then be resumed.

**4** To adjust the mixture setting on Cooper models, it will be necessary to unscrew the plug from the gas sampling pipe which is situated on the right-hand end of the cylinder head, and connect an exhaust gas analyser to the end of the pipe (**see illustration**). On all other models, the exhaust gas analyser should be connected to the take-off point on the exhaust system front pipe, using a gas sampling pipe adapter (which can be obtained

from a Rover dealer). To fit the pipe, jack up the front of the car and support it on axle stands (see "Jacking and vehicle support"). Unscrew the threaded plug from the exhaust system front pipe, screw the gas sampling pipe into the threaded hole, and connect the exhaust gas analyser to the end of the sampling pipe.

### Adjustment

**Note:** If it has been noted that the engine idle speed has become erratic, and a high CO % reading is obtained during the following procedure, it is likely that the carburettor needle valve is faulty. Rover have produced a modified needle valve kit to overcome this problem. Refer to your Rover dealer for further information.

**5** Check that all electrical components are switched off.

**6** Connect a tachometer to the engine in accordance with the maker's instructions.

**7** Allow the engine to idle, and check that the idle speed is as given in the *Specifications*. If adjustment is necessary, turn the screw located on the dashpot base as necessary (**see illustration**).

**8** With the exhaust gas analyser connected as described in paragraph 4, and the engine idling, check that the mixture CO % is as given in the *Specifications*. If not, turn the adjustment screw located on the side of the carburettor body. Turn the screw by small increments, and allow the reading to stabilise between adjustments.

**9** If necessary, re-adjust the idling speed as described in paragraph 7.

**10** Note that if the CO % is adjusted near the 3.0% upper limit, the efficiency of the catalytic converter will be reduced. If the CO reading is

## 16 Carburettor (SU HIF44 and HIF38) - idle speed and mixture adjustment



**Note:** A tachometer and accurately calibrated exhaust gas analyser (CO meter) will be required for the following adjustments. If these

then taken from the exhaust tailpipe, there may be little difference between the two readings. However, this does not mean that the catalytic converter is functioning correctly, and it will not adversely affect the unit.

**11** Check the fast idling speed by pulling out the choke until the arrow on the carburettor fast idle cam is aligned with the adjustment screw. If adjustment is necessary, turn the fast idle screw.

**12** Stop the engine and disconnect the tachometer and exhaust gas analyser. On Cooper models, refit the plug to the sampling pipe. On all other models, remove the sampling pipe, refit and tighten the threaded plug, and lower the vehicle to the ground.

### 17 Anti-run-on valve (1990-on Cooper models) - removal and refitting



#### Removal

**1** The anti-run-on valve is mounted onto a bracket in the right-hand rear corner of the engine compartment. Its function is to prevent the engine running-on ("dieseling") after the ignition is switched off. If the valve is disconnected or damaged, it may prevent the engine from running or idling smoothly.

**2** To remove the valve, disconnect the wiring connector and both hoses from it.

**3** Unscrew the bracket retaining bolt, and remove the valve complete with its bracket.

#### Refitting

**4** Refitting is a reverse of removal, ensuring that the wiring connector and hoses are securely connected.

### 18 Inlet manifold - removal and refitting



#### Removal

**Note:** On vehicles fitted with emission control equipment it will be necessary to remove certain additional fittings, hoses and brackets to provide access to the inlet manifold. The items requiring removal will be obvious after a visual inspection, and full information regarding their removal will be found in Part C of this Chapter.

**1** Refer to Section 12 and remove the carburettor(s) from the inlet manifold.

**2** On models fitted with a brake servo, slacken the retaining clip screw and remove the vacuum hose from the union on the inlet manifold.

**3** If working on Cooper S models, undo and remove the nuts, large flat washers and spring washers securing the manifold to the cylinder head. Lift off the manifold. On all other models proceed as follows.

**4** Chock the rear wheels then jack up the front of the car and support it on axle stands (see "Jacking and vehicle support").

**5** From underneath the car, undo and remove the nut and bolt securing the exhaust front pipe support strap to the transmission bracket.

**6** Undo and remove the two bolts and nuts securing the two halves of the exhaust manifold clamp to the front pipe. Lift away the clamp assembly.

**7** Undo and remove the six nuts and flat washers securing the manifold to the cylinder head (see illustration).

**8** Lift off the hot air shroud, where fitted, and then slide the inlet and exhaust manifold assembly off the studs and withdraw it from the engine. Recover the manifold gasket.

#### Refitting

**9** Refitting is the reverse sequence to removal bearing in mind the following points:

- Ensure that the mating surfaces of the manifold and cylinder head are clean, and use a new gasket.
- Refit the exhaust manifold-to-front pipe clamp before tightening the front pipe support strap bolt.

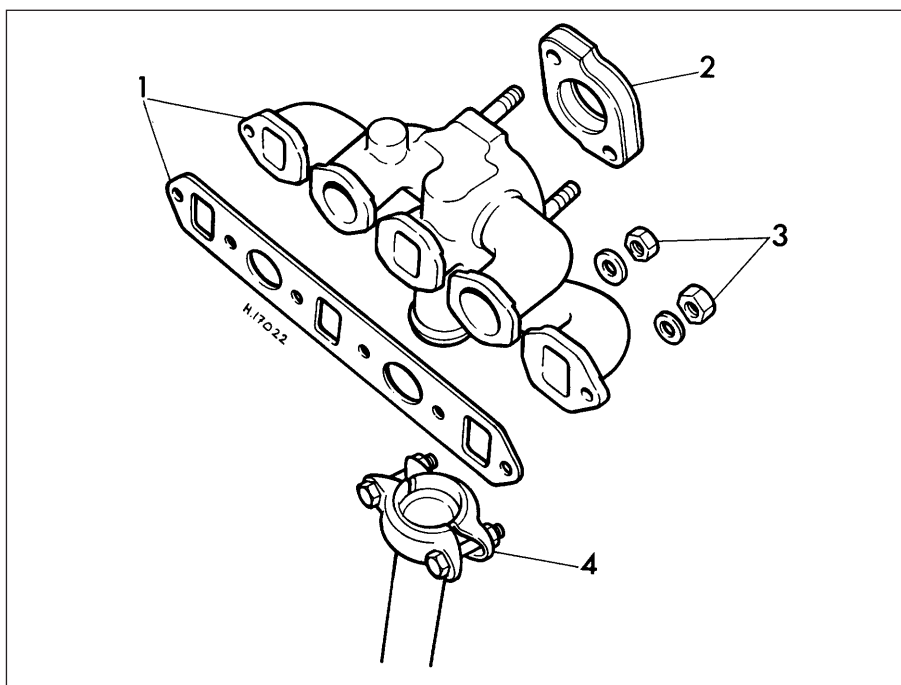

18.7 Inlet and exhaust manifold assembly

1 Manifold and gasket

2 Carburettor insulating block

3 Retaining nuts

4 Manifold-to-front pipe clamp

# Chapter 4 Part B: Fuel system - fuel injection engines

## Contents

Accelerator cable - removal, refitting and adjustment	4	Fuel system - depressurisation	6
Accelerator pedal - removal and refitting	5	Fuel system - pressure check	7
Air cleaner air temperature control system - general information, testing and component renewal	3	Fuel tank - removal and refitting	8
Air cleaner assembly - removal and refitting	2	General information and precautions	1
Air cleaner element renewal	See Chapter 1	Inlet manifold - removal and refitting	15
Fuel filter renewal	See Chapter 1	Inlet manifold PTC heater - general information and component renewal	14
Fuel gauge sender unit - removal and refitting	10	Underbody and fuel/brake line check	See Chapter 1
Fuel injection system - testing and adjustment	12	Underbonnet check for fluid leaks and hose condition	See Chapter 1
Fuel injection system components - removal and refitting	13	Unleaded petrol - general information and usage	11
Fuel pump - removal and refitting	9		

## Degrees of difficulty

<b>Easy</b> , suitable for novice with little experience 	<b>Fairly easy</b> , suitable for beginner with some experience 	<b>Fairly difficult</b> , suitable for competent DIY mechanic 	<b>Difficult</b> , suitable for experienced DIY mechanic 	<b>Very difficult</b> , suitable for expert DIY or professional 
--	---	---	--	---

## Specifications

### General

System type	Rover/Motorola Modular Engine Management System, using ECU-controlled single-point injection (MEMS-Spi) and speed/density method of airflow measurement
-------------	---

### Fuel system data

Fuel pump type	Electric, immersed in fuel tank
Fuel pump regulated pressure	1.0 bar ± 4%
Injector and pressure regulator unit	JZX 3300
Throttle potentiometer voltage:	
Throttle closed	0 to 1 volt
Throttle open	4 to 5 volts
Idle speed - nominal value, for reference only	850 ± 25 rpm
Idle mixture CO %	0.5% maximum

### Recommended fuel

Minimum octane rating	95 RON unleaded <b>only</b>
-----------------------	-----------------------------

### Torque wrench settings

	Nm	lbf ft
Fuel pump nuts	9	6
Throttle body assembly nuts	10	7
Injector housing fuel pipe union nuts	24	18
Injector housing fuel pipe adapters	24	18
Injector housing screws	5	4
Inlet air temperature sensor	7	5
Manifold retaining nuts	22	16
Brake servo vacuum hose union bolt	50	37
Fuel tank breather two-way valve nuts	9	6

## 1 General information and precautions

### General information

The fuel system consists of a fuel tank, situated at the rear of the car, with an electric fuel pump immersed in it, a fuel filter, fuel feed and return lines, and the throttle body assembly (which incorporates the single fuel injector and the fuel pressure regulator), as well as the engine management electronic control unit (ECU) and the various sensors, electrical components and related wiring. The air cleaner contains a disposable paper filter element, and incorporates a flap valve air temperature control system, which allows cold air (from the outside of the car) and warm air (heated by the exhaust manifold) to enter the air cleaner in the correct proportions.

To reduce emissions and to improve driveability when the engine is cold, the inlet manifold is heated by the cooling system coolant and by an electric pre-heater system. Mixture enrichment for cold starting is a pre-programmed function of the system.

The ECU fully controls both the ignition and fuel injection systems, integrating the two in a complete engine management system; refer to Chapter 5B for information on the ignition side of the system.

The Rover/Motorola Modular Engine Management System uses ECU-controlled single-point injection (MEMS-Spi) and the speed/density method of airflow measurement. The whole system is best explained if considered as three sub-systems; the fuel delivery, air metering and electrical control systems.

The fuel delivery system incorporates the fuel tank with an electric fuel pump (immersed in a swirl pot to prevent aeration of the fuel) inside it. When the ignition is switched on, the pump is supplied with current via the fuel pump relay, under the control of the ECU; the pump feeds petrol via a non-return valve (to prevent fuel draining out of the system components and back to the tank when the pump is not working) to the fuel filter, and from the filter to the injector. Fuel pressure is controlled by the pressure regulator, which lifts to allow excess fuel to return to the tank swirl pot, where a venturi causes the returning fuel to draw cool fuel from the tank into the swirl pot. In the event of sudden deceleration (ie, an accident) an inertia switch cuts off the power to the pump, so that the risk of fire from fuel spraying out of broken fuel lines under pressure is minimised.

The air metering system includes the inlet air temperature control system and the air cleaner, but the main components are in the throttle body assembly. This incorporates the injector (which sprays fuel onto the back of the throttle disc), the throttle potentiometer (which is linked to the throttle disc spindle,

and sends the ECU information on the rate of throttle opening by transmitting a varying voltage), and the stepper motor, (which is controlled by the ECU, and operates the throttle disc spindle lever via a cam and pushrod to provide idle speed control).

The electrical control system consists of the ECU, with all the sensors that provide it with information, and the actuators by which it controls the whole system's operation. The ECU's manifold absolute pressure (MAP) sensor is connected, by hoses and a fuel (vapour) trap mounted on the bulkhead, to the inlet manifold; variations in manifold pressure are converted into graduated electrical signals, which are used by the ECU to determine the load on the engine. The inlet air temperature sensor is self-explanatory; the crankshaft sensor provides the engine speed and crankshaft position; the coolant temperature sensor supplies the engine temperature, the accelerator pedal switch tells the ECU when the accelerator is closed; the throttle potentiometer is explained above, and the function of the lambda sensor is explained in Part C of this Chapter. The ECU also senses battery voltage, and can adjust the injector pulses width and use the stepper motor to increase the idle speed and, therefore, the alternator output if it is too low. Short-circuit protection and diagnostic capabilities are incorporated; the ECU can both receive and transmit information via the diagnostic connector, thus permitting engine diagnosis and tuning by Rover diagnostic equipment. If either the coolant temperature sensor, the inlet air temperature sensor or the manifold absolute pressure sensor circuits should fail, the ECU has a back-up facility which assumes a valve corresponding to a coolant temperature of 60°C, an inlet air temperature of 35°C and an engine load based on the engine speed and throttle position; these are used to implement a back-up air/fuel mixture ratio.

All these signals are compared by the ECU, using digital techniques, with set values pre-programmed (mapped) into its memory. Based on this information, the ECU selects fuel and ignition settings appropriate to those values, and controls the ignition HT coil (varying the ignition timing as required), the fuel injector (varying its pulse width - the length of time the injector is held open - to provide a richer or weaker mixture, as appropriate), the stepper motor (controlling the idle and fast idle speeds), the fuel pump relay (controlling the fuel delivery), the manifold heater relay (controlling the inlet manifold pre-heater system) and the main relay, the purge control valve, and the lambda sensor and relay, accordingly. The mixture, idle speed and ignition timing are constantly varied by the ECU to provide the best settings for cranking, starting and engine warm-up (with either a hot or cold engine), idle, cruising, and acceleration. A rev-limiter circuit is built into the ECU, which switches off the

injector earth (ie, the fuel supply) if the engine speed exceeds the recommended limit. The injector earth is also switched off on the overrun, to improve fuel economy and reduce exhaust emissions.

The ECU idle control is an adaptive system; it learns the engine load and wear characteristics over a period of time, and adjusts the idle speed to suit. If the ECU is renewed, or one from another car is fitted, it will take a short period of normal driving for the new ECU to learn the engine's characteristics and restore full idle control.

### Precautions



**Warning:** *Petrol is extremely flammable - great care must be taken when working on any part of the fuel system. Do not smoke or allow any naked flames or uncovered light bulbs near the work area. Note that gas powered domestic appliances with pilot flames, such as heaters, boilers and tumble dryers, also present a fire hazard - bear this in mind if you are working in an area where such appliances are present. Always keep a suitable fire extinguisher close to the work area and familiarise yourself with its operation before starting work. Wear eye protection when working on fuel systems and wash off any fuel spilt on bare skin immediately with soap and water. Note that fuel vapour is just as dangerous as liquid fuel; a vessel that has just been emptied of liquid fuel will still contain vapour and can be potentially explosive. Petrol is a highly dangerous and volatile liquid, and the precautions necessary when handling it cannot be overstressed.*

*Many of the operations described in this Chapter involve the disconnection of fuel lines, which may cause an amount of fuel spillage. Before commencing work, refer to the above Warning and the information in "Safety first" at the beginning of this manual.*

*When working with fuel system components, pay particular attention to cleanliness - dirt entering the fuel system may cause blockages which will lead to poor running.*

**Note:** *Residual pressure will remain in the fuel lines long after the vehicle was last used, when disconnecting any fuel line, it will be necessary to depressurise the fuel system as described in Section 6.*

## 2 Air cleaner assembly - removal and refitting



### Removal

**1** Slacken and remove the three screws securing the air cleaner assembly to the throttle body (see illustration).



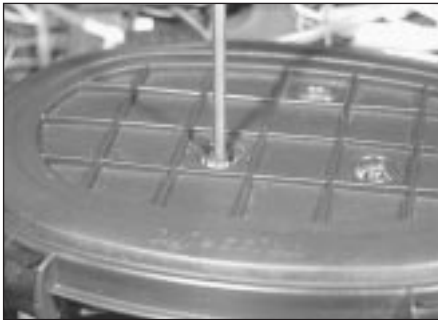

2.1 Undo the three retaining screws . . .



2.2a . . . then lift up the air cleaner assembly, and disconnect the intake air temperature sensor wiring connector . . .



2.2b . . . and the thermac valve vacuum pipe

2 Lift up the assembly, then disconnect the wiring connector from the air temperature sensor, and the inlet manifold vacuum pipe from the thermac valve (see illustrations).

3 Remove the air cleaner assembly, and recover its sealing ring from the throttle body flange.

**Refitting**

4 Refitting is the reverse sequence to removal, ensuring that the sealing ring is correctly located on the throttle body flange.

**3 Air cleaner air temperature control system** - information, testing and component renewal 

**General information**

1 The system is controlled by a thermac valve/switch mounted in the air cleaner assembly; when the engine is started from cold, the switch is closed, to allow inlet manifold depression to act on the air temperature control valve in the inlet duct. This raises a vacuum diaphragm in the valve assembly, and draws a flap valve across the cold air inlet, thus allowing only (warmed) air from the exhaust manifold to enter the air cleaner.

2 As the temperature of the exhaust-warmed air in the air cleaner rises, a bi-metallic strip in the thermac switch deforms, opening the switch to shut off the depression in the air temperature control valve assembly. The flap is lowered gradually across the hot air inlet until, when the engine is fully warmed-up to normal operating temperature, only cold air from the front of the inlet duct is entering the air cleaner.

**Testing**

3 To check the system, allow the engine to cool down completely, then unclip the inlet duct from the air cleaner body; the flap valve in the duct should be securely seated across the hot air inlet. Start the engine; the flap should immediately rise to close off the cold air inlet, and should then lower steadily as the engine warms up, until it is eventually seated across the hot air inlet again.

4 To check the thermac switch, disconnect the vacuum pipe from the control valve when the engine is running, and place a finger over the pipe end. When the engine is cold, full inlet manifold vacuum should be present in the pipe, and when the engine is at normal operating temperature, there should be no vacuum in the pipe.

5 To check the air temperature control valve, unclip the inlet duct from the air cleaner body; the flap valve should be securely seated across the hot air inlet. Disconnect the vacuum pipe, and suck hard at the control valve stub; the flap should rise to shut off the cold air inlet.

6 If either component is faulty, it must be renewed as described below.

**Component renewal**

**Thermac switch**

7 Remove the air cleaner assembly as described in Section 2.

8 Release the lid retaining clips, then remove the lid and withdraw the air cleaner filter element.

9 Disconnect the vacuum pipe (see illustration), then bend up the tags on the switch clip. Remove the clip, then withdraw the switch and its seal.

10 Refitting is the reverse sequence to removal, ensuring that the switch mating surfaces are clean, and that the switch and seal are correctly located before fastening the clip.



3.9 Disconnecting the vacuum pipe from the thermac valve

**Air temperature control valve**

11 Disconnect the vacuum pipe from the valve, then unclip the inlet duct from the air cleaner and remove it from the engine compartment.

12 The air temperature control valve can be renewed only with the complete inlet duct assembly. If a new inlet duct assembly is being fitted, undo the three screws securing the hot air inlet adapter plate to the bottom of the duct, and transfer the adapter plate to the new duct (see illustration).

13 Clip the duct into position in the air cleaner, and reconnect the vacuum pipe.

**4 Accelerator cable** - removal, refitting and adjustment 

**Removal**

1 Remove the air cleaner assembly as described in Section 2.

2 Remove the engine management ECU as described Section 13.

3 Slacken the accelerator cable locknuts, and free the outer cable from its mounting bracket. Release the inner cable from the throttle cam.

4 Work back along the outer cable, releasing it from any relevant retaining clamps and ties, and from the engine compartment bulkhead.

5 Working from inside the car release the heater duct from underneath the driver's side of the fascia panel, to gain access to the upper end of the accelerator pedal.



3.12 Removing the air cleaner intake duct adapter

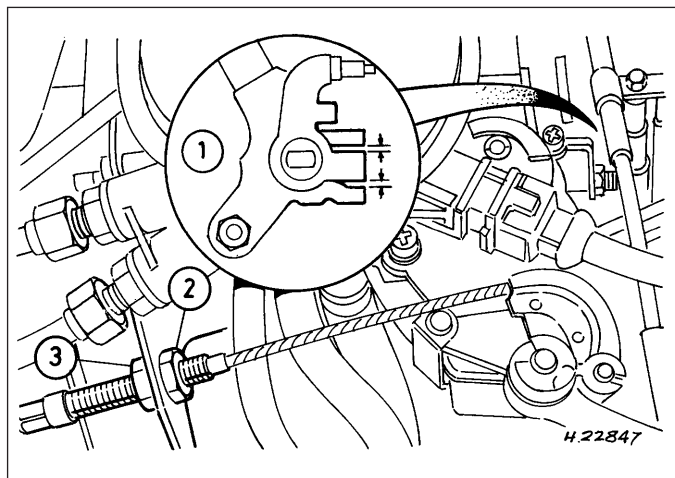

4.8 Accelerator cable adjustment - fuel-injected models

- |   |                    |
|---|--------------------|
| 1 Throttle lever-to-lost motion link clearance should be equal on each side | 2 Adjuster locknut |
|   | 3 Adjuster nut     |

6 Remove the accelerator cable retaining clip, then release the cable from the upper end of the accelerator pedal. Return to the engine compartment, and withdraw the cable from the bulkhead.

### Refitting and adjustment

7 Refitting is the reverse sequence to removal, ensuring that the cable is correctly routed. Prior to tightening the cable locknuts, the cable should be adjusted as follows.

8 With the pedal fully released, position the locknuts so that there is equal clearance present on each side of the throttle lever at the lost motion link and no slack in the cable (**see illustration**). Have an assistant fully depress the pedal, and check that the throttle cam opens fully, then check that it returns to the at-rest position when released.

9 To adjust the cable, switch on the ignition and position the stepper motor by moving the cam only to open, and fully close the throttle (**see illustration**). Note that it is essential for accurate positioning of the stepper motor that the accelerator pedal switch contacts remain closed, so that the ECU recognises the throttle movement as a command, and indexes the stepper motor.

10 Slacken the adjuster locknut, then tighten the adjuster nut until the clearance is equal on each side of the throttle lever at the lost motion link, tighten the locknut without disturbing this setting (**see illustration**). Recheck the adjustment, and switch off the ignition.

### 5 Accelerator pedal - removal and refitting



Refer to Part A, Section 4.

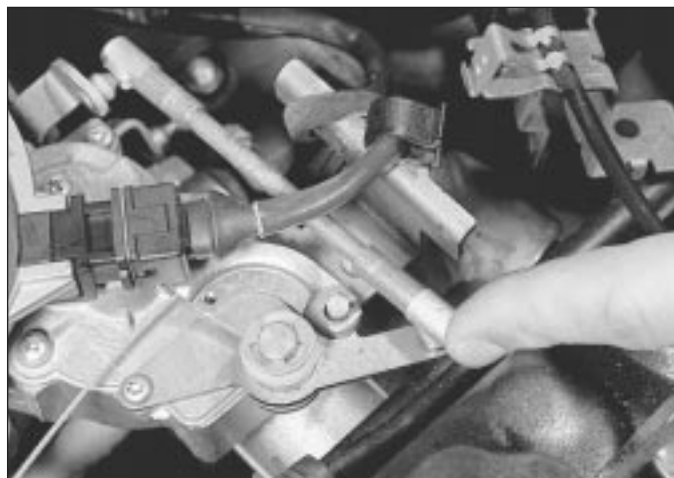

4.9 To adjust the accelerator cable, index the stepper motor . . .

### 6 Fuel system - depressurisation



**Note:** Refer to the warning note in Section 1 before proceeding.



**Warning:** The following procedure will merely relieve the pressure in the fuel system - remember that fuel will still be present in the system components, and take precautions accordingly before disconnecting any of them.

1 The fuel system referred to in this Section is defined as the tank mounted fuel pump, the fuel filter, the fuel injector and the pressure regulator in the injector housing, and the metal pipes and flexible hoses of the fuel lines between these components. All these contain fuel which will be under pressure while the engine is running and/or while the ignition is switched on. The pressure will remain for some time after the ignition has been switched off, and must be relieved before any of these components are disturbed for servicing work.

2 Disconnect the battery negative lead.



4.10 . . . then adjust the locknut and adjuster nut as described in text

3 Place a suitable container beneath the relevant connection/union to be disconnected, and have a large rag ready to soak up any escaping fuel not being caught by the container.

4 Loosen the connection or union nut (as applicable) slowly to avoid a sudden release of pressure, and position the rag around the connection to catch any fuel spray which may be expelled. Once the pressure is released, disconnect the fuel line, and insert suitable plugs to minimise fuel loss and prevent the entry of dirt into the fuel system.

### 7 Fuel system - pressure check



**Note:** The following procedure is based on the use of the Rover pressure gauge and adapter (service tool number 18G1500).

1 Depressurise the fuel system as described in Section 6, then release the retaining clip and disconnect the flexible fuel feed hose at its union to the metal fuel pipe which is secured to the engine compartment bulkhead, just behind the throttle body assembly; the feed pipe is the lower of the two.

2 Connect the gauge into the fuel line between the hose and pipe, and check that it is securely retained.

3 Reconnect the battery and start the engine; the pressure should be steady at the specified regulated injection pressure. Stop the engine and watch the gauge; the pressure drop in the first minute should not exceed 0.7 bars.

4 If the regulated pressure recorded was too high, the pressure regulator must be renewed; this means renewing the complete injector housing assembly.

5 If the pressure first recorded was too low, or if it falls too quickly, check the system carefully for leaks. If no leaks are found, first

renew the fuel filter (see Chapter 1), then check the pump by substituting a new one, and recheck the pressure. If the pressure does not improve, the fault is in the pressure regulator, and the complete injector housing assembly must be renewed; if this is the case, it is worth dismantling the regulator first to check that the fault is not due to its being jammed open with dirt, or similar.

## 8 Fuel tank - removal and refitting



**Note:** Observe the precautions in Section 1 before working on any component in the fuel system.

### Removal

- 1 Before the tank can be removed, it must be drained of as much fuel as possible. To avoid the dangers and complications of fuel handling and storage, it is advisable to carry out this operation with the tank almost empty. Any fuel remaining can be drained as follows.
- 2 Disconnect the battery negative lead.
- 3 Using a hand pump or syphon inserted through the filler neck, remove any remaining fuel from the bottom of the tank. Do this in a well ventilated area, not in a garage or over an inspection pit
- 4 Remove the luggage compartment carpet and the spare wheel.
- 5 Release the two retaining studs, and remove the trim panel from the side of the fuel tank.
- 6 Disconnect the wiring connectors from the fuel gauge sender unit.
- 7 Release the retaining clip, and disconnect the vent pipe from the fuel tank.
- 8 Bearing in mind the information contained in Section 6 on depressurising the fuel system, release the retaining clips and disconnect the fuel feed and return hoses from the tank; the feed hose is marked with a yellow band, and the return hose is unmarked.
- 9 Undo the fuel tank strap retaining bolt, then remove the strengthening plate and move the strap to one side.
- 10 Release the fuel tank filler neck from its grommet, and remove the grommet from the car.
- 11 Peel back the rubber cover, then disconnect the wiring connector from the fuel pump, and remove the fuel tank from the vehicle.

### Refitting

- 12 Refitting is the reverse sequence to removal, ensuring that all hoses are correctly reconnected and securely fastened so that there can be no risk of fuel leakage.

## 9 Fuel pump - removal and refitting



**Note:** Observe the precautions in Section 1 before working on any component in the fuel system.

### Removal

- 1 Remove the fuel tank as described in Section 8.
- 2 Release the retaining clip, and disconnect the two-way breather valve vent hose from the fuel tank. Unclip the valve and hose assembly from the tank seam, and remove it.
- 3 Slacken and remove the six fuel pump retaining nuts, then carefully withdraw the pump assembly from the tank, and remove the pump seal.

### Refitting

- 4 Examine the pump seal for signs of damage or deterioration and, if necessary, renew it.
- 5 Ensure that the pump and tank mating surfaces are clean and dry, and fit the seal onto the fuel tank.
- 6 Carefully install the pump assembly, then refit the pump retaining nuts and tighten them to the specified torque.
- 7 Clip the two-way valve and hose assembly back onto the tank seam, then reconnect the vent hose to the tank, securing it in position with its retaining clip.
- 8 Refit the fuel tank as described in Section 8.

## 10 Fuel gauge sender unit - removal and refitting



Refer to Part A, Section 8.

## 11 Unleaded petrol - general information and usage

**Note:** The information given in this Chapter is correct at the time of writing. If updated information is thought to be required, check with a Rover dealer. If travelling abroad, consult one of the motoring organisations (or a similar authority) for advice on the fuel available.

All fuel injection models are designed to run on fuel with a minimum octane rating of 95 (RON). All models are equipped with catalytic converters, and therefore must be run on unleaded fuel **only**. Under no circumstances should leaded fuel be used, as this may damage the catalytic converter.

Super unleaded petrol (97/98 RON) can also be used in all models if wished, though there is no advantage in doing so.

## 12 Fuel injection system - testing and adjustment



### Testing

- 1 If a fault appears in the fuel injection system, first ensure that all the system wiring connectors are securely connected and free of corrosion. Ensure that the fault is not due to poor maintenance; ie, check that the air cleaner filter element is clean, the spark plugs are in good condition and correctly gapped, the valve clearances are correctly adjusted, the cylinder compression pressures are correct, and that the engine breather hoses are clear and undamaged, referring to Chapters 1 and 2 for further information.
- 2 If these checks fail to reveal the cause of the problem, the vehicle should be taken to a suitably-equipped Rover dealer for testing. A wiring block connector is incorporated in the engine management circuit, into which a special electronic diagnostic tester can be plugged. The tester will locate the fault quickly and simply, alleviating the need to test all the system components individually, which is a time-consuming operation that also carries a risk of damaging the ECU.

### Adjustment

- 3 Experienced home mechanics with a considerable amount of skill and equipment (including a tachometer and an accurately calibrated exhaust gas analyser) may be able to check the exhaust CO level and the idle speed. However, if these are found to be in need of adjustment, the car *must* be taken to a suitably-equipped Rover dealer for further testing. **Note:** There is no provision for the adjustment or alteration of these settings, except by reprogramming the ECU using Rover diagnostic equipment; if checking the idle speed, remember that it will vary constantly under ECU control.

## 13 Fuel injection system components - removal and refitting



### Throttle body

**Note:** Refer to the warning note in Section 1 before proceeding.

### Removal

- 1 Remove the air cleaner assembly, as described in Section 2.
- 2 Slacken and remove the bolt and retaining clip securing the fuel pipes to the bulkhead (see illustration). Examine the injector housing fuel pipe feed and return unions for signs of leakage, then wipe them clean.
- 3 Bearing in mind the information contained in Section 6 on depressurising the fuel system, using an open-ended spanner to hold



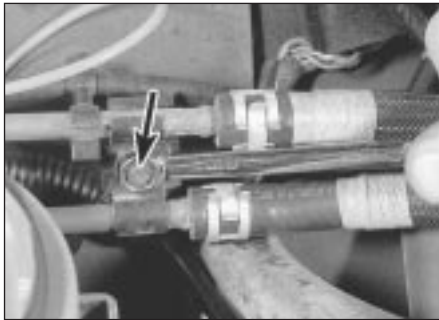

**13.2 Undo the retaining bolt (arrowed) and remove the fuel pipe retaining clip**

each adapter, unscrew the pipe union nuts, and release the fuel feed and return pipes from the adapters (**see illustration**). Plug each pipe and adapter, to minimise the loss of fuel and prevent the entry of dirt into the system.

**4** Release the wire retaining clips, and disconnect the wiring connectors from the injector housing, the throttle potentiometer and the stepper motor.

**5** Slacken the accelerator cable locknuts, and free the outer cable from its mounting bracket. Release the inner cable from the throttle cam.

**6** Release the retaining clip(s), and disconnect the breather and purge valve hoses from the front of the throttle body (**see illustration**).

**7** On models with automatic transmission, disconnect the governor control rod from the throttle linkage.

**8** Slacken and remove the four nuts securing the throttle body to the inlet manifold, then remove the throttle body from the car. Remove the insulating spacer, and examine it for signs of wear or damage, renewing it if necessary.

**9** If leakage was detected from the feed and return pipes or their union nuts, check the sealing surfaces of the nuts and adapters, and renew the adapter or the pipe assembly as necessary. If leakage was detected from the adapters, unscrew each through one turn with a spanner, then through two turns by hand; if the adapter is still a tight fit in the housing, the threads are damaged, and the housing and adapters must be renewed as a set. If the



**13.12 Disconnecting the injector housing wiring connector**



**13.3 Retain the adapters with an open-ended spanner whilst slackening the fuel pipe union nuts**

threads are sound, fit new sealing washers to the adapters and refit them, tightening them to their specified torque wrench setting.

### Refitting

**10** Refitting is the reverse sequence to removal, noting the following points:

- Ensure that the mating surfaces of the throttle body and inlet manifold are clean, then fit the insulating spacer.
- Tighten the throttle body nuts and fuel pipe union nuts to their specified torque settings. Note that when tightening the injector housing fuel pipe union nuts, **do not** use an open-ended spanner to retain the adapters; this will ensure that the adapters are securely tightened in the injector housing.
- On completion, reconnect and adjust the accelerator cable as described in Section 4.

### Injector housing

**Note:** Refer to the warning note in Section 1 before proceeding.

#### Removal

**11** Carry out the operations described in paragraphs 1 to 3.

**12** Release the wire retaining clip, and disconnect the wiring connector from the injector housing (**see illustration**).

**13** Remove the four screws securing the injector housing to the throttle body (**see illustration**), then lift off the injector housing and remove the gasket.

**14** If leakage was detected from the fuel feed

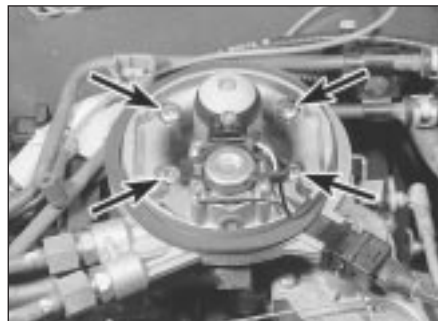

**13.13 Injector housing retaining screws (arrowed)**



**13.6 Disconnect the breather and purge valve hoses from the front of the throttle body assembly**

and/or return pipes, perform the checks described in paragraph 9.

### Refitting

**15** Refitting is the reverse sequence to removal, noting the following points:

- Ensure that the injector and throttle body mating surfaces are clean, and fit a new gasket.
- Apply thread-locking compound (Rover recommended Loctite Screwlock or Nutlock) to the threads of the injector housing screws, then tighten them to the specified torque.
- Tighten the fuel pipe union nuts to the specified torque setting, noting that when tightening the union nuts, **do not** use an open-ended spanner to retain the adapters; this will ensure that the adapters are securely tightened in the housing.

### Fuel injector

**Note:** As a Rover replacement part, the injector is available only as part of the injector housing. Note, however, that it is a Bosch-manufactured component, and can be obtained separately through Bosch agents. Refer to the warning note in Section 1 before proceeding.

#### Removal

**16** Disconnect the battery negative lead.

**17** Remove the air cleaner assembly as described in Section 2.

**18** Slacken and remove the injector connector cap retaining screw, and lift off the connector cap (**see illustration**). As the screw is slackened, place a clean rag over the cap to catch any fuel spray which may be released. The injector can then be lifted out of the housing.

### Refitting

**19** Refitting is the reverse sequence to removal, ensuring that the connector cap makes good contact with the injector pins.

### Fuel pressure regulator

**20** The fuel pressure regulator is available only as part of the injector housing assembly. Refer to paragraphs 11 to 15 for details on removal and refitting.



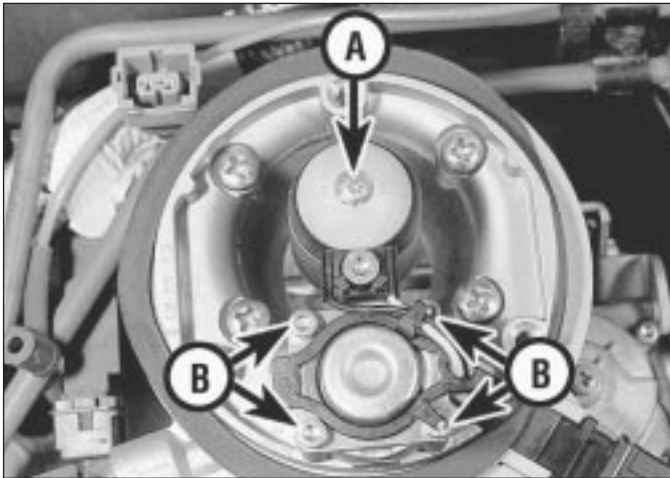

13.18 Injector cap retaining screw "A" and fuel pressure regulator retaining screws "B"



13.30 Undo the ECU mounting bracket-to-wing valance retaining bolts (arrowed) . . .

### Stepper motor

#### Removal

- 21 Remove the injector housing as described in paragraphs 11 to 14.
- 22 Release the retaining clip, and disconnect the stepper motor wiring connector.
- 23 Remove the four stepper motor retaining screws, and remove the stepper motor assembly from the throttle body. Do not attempt to dismantle the assembly.

#### Refitting

- 24 Refitting is the reverse sequence to removal, ensuring that the throttle body and motor mating surfaces are clean. On completion, adjust the accelerator cable as described in Section 4, to ensure that the stepper motor is correctly indexed.

### Throttle potentiometer

#### Removal

- 25 Although not strictly necessary, access is greatly improved if the air cleaner assembly is first removed, as described in Section 2.
- 26 Disconnect the battery negative lead.
- 27 Release the wire retaining clip, and disconnect the potentiometer wiring connector.



13.31 . . . then withdraw the ECU and disconnect the vacuum hose and wiring connectors

- 28 Remove the two screws, and remove the potentiometer from the throttle body, noting how its tongue engages with the throttle disc spindle lever. Withdraw the spacer if required.

#### Refitting

- 29 Refitting is the reverse sequence to removal, noting the following points:
  - a) Carefully clean the mating surfaces of the throttle body, the spacer and the potentiometer, then refit the spacer.
  - b) Refit the potentiometer so that its tongue engages FORWARD of (ie "inside") the throttle disc spindle lever, then rotate the throttle cam to check the action of the lever and tongue.
  - c) Securely tighten the potentiometer screws, then recheck the potentiometer operation before reconnecting the wiring connector.

### Engine management ECU

#### Removal

- 30 Disconnect the battery negative lead, and undo the two bolts securing the ECU mounting bracket to the right-hand wing valance (see illustration).
- 31 Withdraw the ECU from the engine



13.36 Removing the manifold absolute pressure (MAP) sensor fuel

- compartment, disconnecting its wiring connectors and the manifold absolute pressure sensor vacuum hose as they become accessible (see illustration).

- 32 If necessary, undo the three screws and separate the ECU from its mounting bracket.

#### Refitting

- 33 Refitting is the reverse sequence to removal, ensuring that the wiring connectors and vacuum hose are securely reconnected. Due to the nature of the ECU, if a new or different ECU has been fitted, it may take a short while for full idle control to be restored.

### Manifold absolute pressure (MAP) sensor

- 34 This is part of the ECU, and is removed and refitted as described in the previous subsection.

- 35 The sensor's vacuum hose runs from the inlet manifold to the ECU via a fuel (vapour) trap mounted on the engine compartment bulkhead.

- 36 To remove the fuel trap, first remove the air cleaner assembly as described in Section 2. Release the fuel trap from its retaining clip, then disconnect the two vacuum hoses, noting their correct fitted positions, and remove it from the engine compartment (see illustration).

- 37 On refitting, ensure that the vacuum hoses are reconnected to their original unions; the hoses are colour-coded to ensure correct reconnection.

### Inlet air temperature sensor

#### Removal

- 38 Disconnect the battery negative lead.
- 39 Remove the air cleaner assembly as described in Section 2.
- 40 Unscrew the sensor, and remove it from the base of the air cleaner housing (see illustration).



13.40 Removing the intake air temperature sensor from the air cleaner housing



13.47 Disconnect the wiring connector . . .

**Refitting**

41 Refitting is the reverse sequence to removal. Tighten the sensor to the specified torque wrench setting.

**Coolant temperature sensor - removal and refitting**

**Removal**

42 The coolant temperature sensor is fitted to the underside of the inlet manifold, and access to the sensor is strictly limited. Therefore, to remove the sensor, it will first be necessary to remove the inlet manifold as described in Section 15. The sensor can be unscrewed and removed from the manifold.

**Refitting**

43 Wipe clean the threads of the switch and inlet manifold. If a sealing washer is fitted, apply a smear of sealant to the switch threads.

44 Refit the switch to the manifold, and tighten it securely. Refit the manifold as described in Section 15.

**Accelerator pedal switch**

**Removal**

45 Working from inside the car, release the heater duct from underneath the driver's side of the fascia panel, and position it clear of the accelerator pedal.

46 Using a suitable pair of pliers, unhook the accelerator pedal return spring from the pedal.

47 Release the switch wiring connector from its retaining clip, and disconnect it (see illustration).

48 Slacken and remove the accelerator pedal switch mounting bracket retaining bolt, and remove the switch and bracket assembly from the car (see illustration).

49 Prise off the C-clip, and remove the switch from the mounting bracket, noting the wave washer which is fitted between the switch and bracket.

**Refitting**

50 Refitting is the reverse sequence to removal.

**Fuel cut-off inertia switch**

51 The fuel cut-off inertia switch is mounted onto the left-hand side of the engine compartment bulkhead (see illustration). If the switch has tripped, it can be reset by pressing in the button situated at the top of the switch.

**Removal**

52 Slacken and remove the two screws securing the cut-off switch to the bulkhead, then disconnect the wiring connector and remove the switch.

**Refitting**

53 Reconnect the wiring connector, then refit the switch to the bulkhead and tighten its retaining screws securely. Reset the switch by depressing the button on the top of the switch.

**Relay module**

54 The relay module contains the four main relays which control the engine management system; the starter relay, the fuel pump relay,



13.48 . . . then undo the retaining bolt (arrowed) and remove the accelerator pedal switch assembly from the car

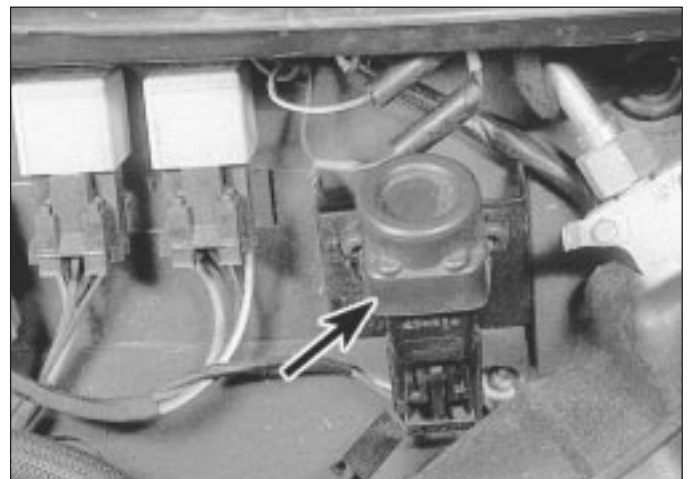

13.51 Fuel cut-off inertia switch (arrowed) is mounted onto the left-hand side of the engine compartment bulkhead

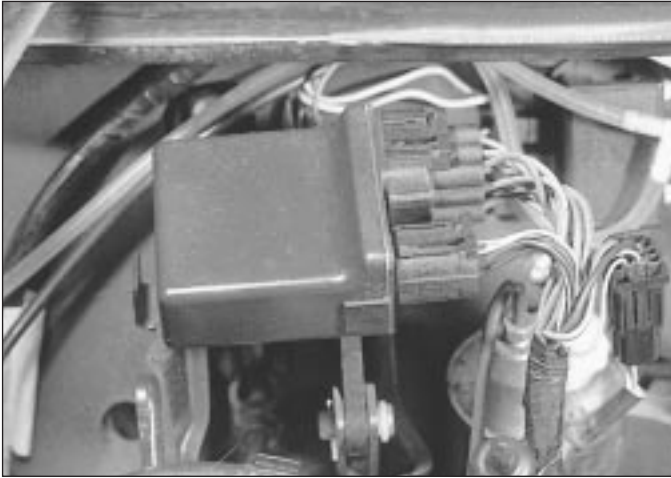

**13.55** Relay module is situated on the right-hand side of the engine compartment

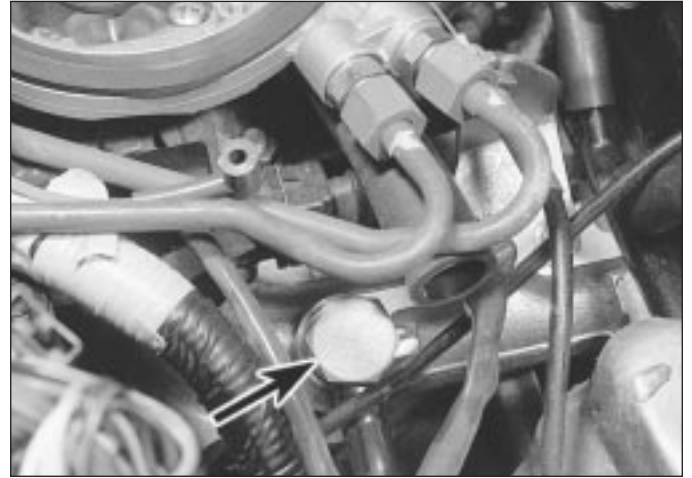

**15.6** Inlet manifold brake servo unit vacuum hose union bolt (arrowed)

the main relay and the manifold PTC heater relay. If a fault develops in any one of the system relays, the complete relay module must be renewed; it is not possible to renew the separate relays individually.

#### Removal

**55** Slide the relay off its mounting bracket in the right-hand rear corner of the engine compartment, then disconnect its wiring connectors and remove it from the car (see illustration).

#### Refitting

**56** Refitting is the reverse sequence to removal.

### 14 Inlet manifold PTC heater - general information and component renewal



#### General information

**1** The system incorporates the manifold PTC (Positive Temperature Coefficient) heater, the relay and the coolant temperature sensor.

**2** When the ignition is switched on and the engine is cold (coolant below 50°C), the relay-energising current is supplied by the engine management ECU, which then closes the relay contacts and allows current to flow from the battery to the heater. This ensures that the inlet manifold is warm enough, even before the effect of the coolant heating becomes apparent, to prevent fuel droplets condensing in the manifold, thus improving driveability and reducing exhaust emissions when the engine is cold.

**3** As soon as the engine warms up to temperatures above 50°C, the ECU switches off the supply current, and the relay cuts off the power supply to the manifold heater.

**4** If the engine suddenly develops flat spots when cold, the system may be faulty.

#### Component renewal

##### PTC heater

**5** The PTC heater is fitted to the underside of the inlet manifold, and access to the heater is strictly limited. Therefore, to remove the heater, it will first be necessary to remove the inlet manifold as described in Section 15. With the manifold on the bench, using circlip pliers, remove the circlip and withdraw the heater. Inspect the rubber sealing ring for signs of damage or deterioration, and renew if necessary.

**6** On refitting, ensure that the heater locating projection is correctly engaged in the manifold recess, then secure the switch in position with its circlip. Refit the manifold to the car as described in Section 15.

##### PTC heater relay

**7** The manifold PTC heater relay is an integral part of the relay module, and can be removed and refitted as described in Section 13.

### 15 Inlet manifold - removal and refitting



#### Removal

**1** Disconnect the battery negative lead.  
**2** Remove the bonnet as described in Chapter 11.

**3** Remove the air cleaner assembly as described in Section 2.

**4** Drain the cooling system as described in Chapter 1.

**5** Carry out the operations described in paragraphs 2 to 7 of Section 13.

**6** Undo the union bolt securing the brake servo vacuum hose to the manifold, and recover the hose union sealing washers (see illustration).

**7** Slacken the two hose clips, and disconnect

the two coolant hoses from the left-hand side of the manifold.

**8** Disconnect the two vacuum hoses from the rear of the inlet manifold, noting their correct fitted positions; the hoses are colour coded for identification purposes.

**9** Slacken and remove the four nuts securing the inlet manifold to the cylinder head, then remove the manifold from the engine, disconnecting the manifold PTC heater and coolant temperature sensor wiring connectors as they become accessible. Remove the two rings from the inlet manifold bore.

#### Refitting

**10** Refitting is the reverse sequence to removal, noting the following points:

- a) Although not strictly necessary, it is also recommended that the exhaust manifold is removed, as described in Part C of this Chapter, so that the manifold gasket can be renewed before the inlet manifold is refitted.
- b) If leakage was detected from the fuel feed and/or return pipes, perform the checks described in Section 13, paragraph 9.
- c) Ensure that the manifold and gasket faces are clean, and that the two locating rings are in position in the manifold bores before refitting the manifold.
- d) Tighten the manifold retaining nuts to the specified torque setting.
- e) Ensure that all relevant hoses are reconnected to their original positions, and are securely held (where necessary) by the retaining clips.
- f) Renew the vacuum servo unit vacuum hose banjo union sealing washers, and tighten the union bolt to the specified torque.
- g) Prior to refitting the air cleaner assembly, adjust the accelerator cable as described in Section 4.
- h) On completion, refill the cooling system as described in Chapter 1.

# Chapter 4 Part C: Exhaust and emission control systems

## Contents

Air pump drivebelt check and renewal . . . . .	See Chapter 1	Exhaust emission control system (models without catalytic converter) - checking and component renewal . . . . .	7
Catalytic converter - general information and precautions . . . . .	9	Exhaust manifold - removal and refitting . . . . .	4
Crankcase emission control system - checking and component renewal . . . . .	5	Exhaust system check . . . . .	See Chapter 1
Emission control system check . . . . .	See Chapter 1	Exhaust system (models with catalytic converter) - removal and refitting . . . . .	3
Evaporative emission control system - checking and component renewal . . . . .	6	Exhaust system (models without catalytic converter) - removal and refitting . . . . .	2
Exhaust emission control system (models with catalytic converter) - checking and component renewal . . . . .	8	General information . . . . .	1
		Underbonnet check for fluid leaks and hose condition . . . . .	See Chapter 1

## Degrees of difficulty

<p><b>Easy</b>, suitable for novice with little experience</p> 	<p><b>Fairly easy</b>, suitable for beginner with some experience</p> 	<p><b>Fairly difficult</b>, suitable for competent DIY mechanic</p> 	<p><b>Difficult</b>, suitable for experienced DIY mechanic</p> 	<p><b>Very difficult</b>, suitable for expert DIY or professional</p> 
--	---	---	--	---

## Specifications

Torque wrench settings	Nm	lbf ft
Thermostatic vacuum valve - 1992-on models . . . . .	10	7
Manifold retaining nuts . . . . .	22	16
Lambda sensor . . . . .	55	41
Fuel tank breather two-way valve nuts . . . . .	9	6



**1 General information**

**Exhaust system**

The exhaust system fitted to all Mini models covered by this manual, except Cooper S, consists of an exhaust manifold and a tubular steel exhaust system in either single or multiple sections. A single silencer is fitted to the rear section of early models; later versions incorporate an additional intermediate silencer or catalytic converter. The system fitted to Cooper S models comprises a three branch manifold, a front pipe and separate tailpipe incorporating a silencer. Certain versions have a second silencer located beneath the floor pan.

On all models the exhaust system is flexibly attached to the car by two rubber mountings on the rear subframe and a bracket at the base of the transmission.

**Emission control systems**

Certain early models and all later models covered by this manual have various features

built into the fuel and exhaust systems to help minimise harmful emissions. These features fall broadly into three categories; crankcase emission control, evaporative emission control, and exhaust emission control. The main features of these systems are as follows.

**Crankcase emission control**

To reduce the emissions of unburned hydrocarbons from the crankcase into the atmosphere, a positive crankcase ventilation system is used whereby the engine is sealed and the blow-by gasses and oil vapour are drawn from inside the crankcase, through an oil separator, into the inlet tract to be burned by the engine during normal combustion.

Under conditions of high manifold depression (idling, deceleration) the gasses will be sucked positively out of the crankcase. Under conditions of low manifold depression (acceleration, full-throttle running) the gasses are forced out of the crankcase by the (relatively) higher crankcase pressure; if the engine is worn, the raised crankcase pressure (due to increased blow-by) will cause some of the flow to return under all manifold conditions.

**Evaporative emission control**

The evaporative emission control system is used to minimise the escape of unburned hydrocarbons into the atmosphere.

The fuel tank filler cap is sealed, and a charcoal canister is mounted underneath the left-hand wheel arch to collect the petrol vapours generated in the tank, and on some models in the carburettor float chamber, when the car is parked. It stores them until they can be cleared from the canister into the inlet tract, to be burned by the engine during normal combustion.

On early carburettor models, the vapours were drawn into the inlet tract whenever the engine was running. On later catalytic converter equipped carburettor models, a thermostatic vacuum valve screwed into the front of the thermostat housing controls the flow of vapour from the canister to the engine. To ensure that the engine runs correctly when it is cold, and to protect the catalytic converter from the effects of an over-rich mixture, the thermostatic vacuum valve does not open until the engine has warmed up to approximately 70°C. The valve then allows inlet manifold vacuum to act upon the purge valve vacuum diaphragm fitted to the top of the charcoal canister, which in turn opens the

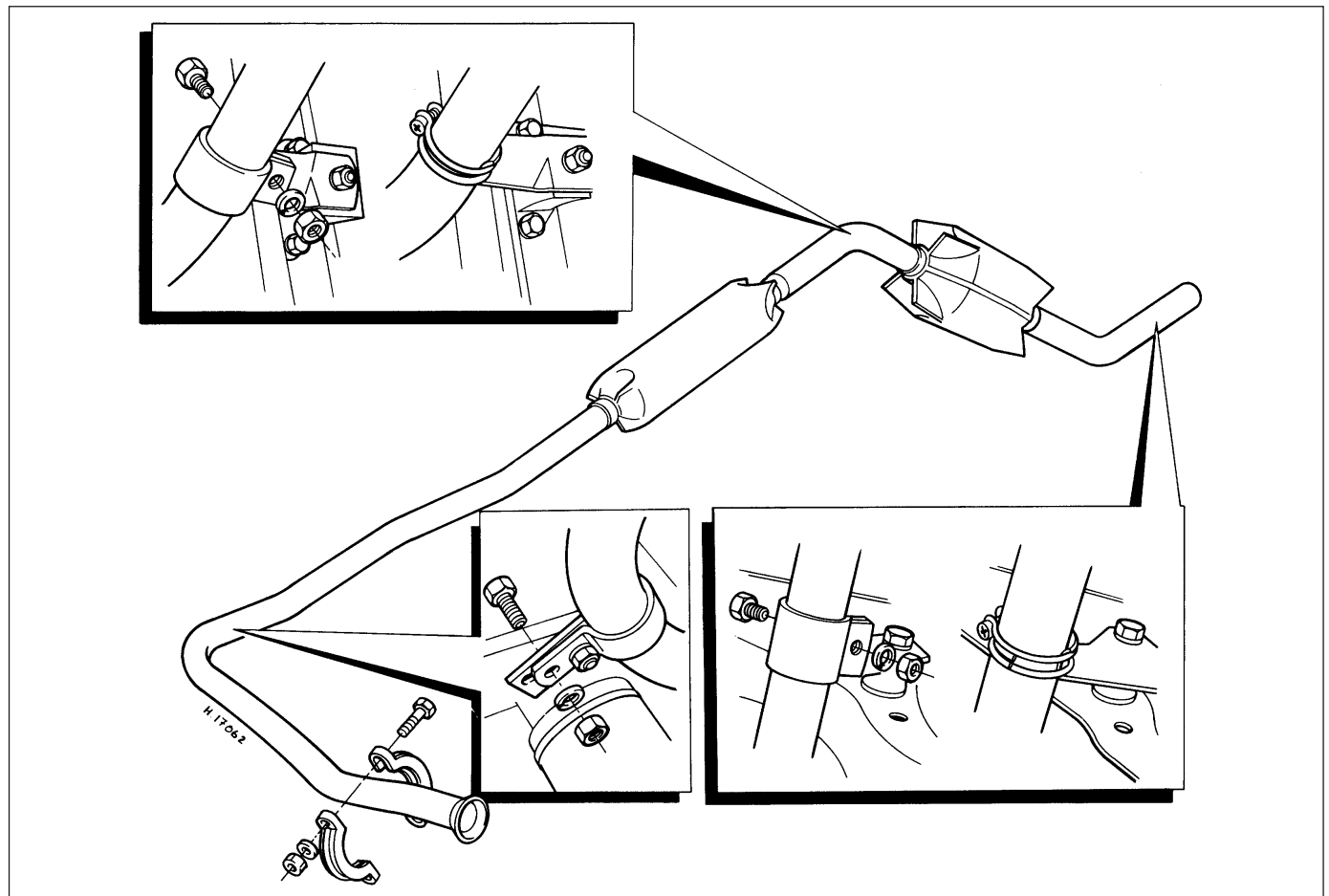

2.2 Typical exhaust system support brackets and mountings

canister and allows the stored vapour into the inlet tract.

On fuel injection models, the engine management ECU controls the flow of vapour from the canister to the engine, via an electrically-operated purge control valve.

The purge control valve is not opened by the ECU until the engine has warmed up to above 70°C, the engine speed exceeds 1500 rpm and manifold absolute pressure is below 30 kPa; the control valve solenoid is then modulated on and off to allow the stored vapour to pass into the inlet tract.

### Exhaust emission control - carburettor models without catalytic converter

The basis of this system, used on certain early models, is an air pump which supplies air under pressure to the cylinder head exhaust port of each cylinder, via an air injection manifold. A check valve is incorporated in the air delivery pipe to prevent a blow-back of exhaust gases from reaching the pump. Air from the pump is also supplied to the inlet manifold via a gulp valve to weaken the rich fuel/air mixture in the manifold during engine deceleration and overrun.

The air pump is of the rotary vane type and is mounted at the front of the cylinder head. Drive to the pump is by a V-belt from the water pump pulley. Air enters the pump through an extraction filter on early models, or through radial air inlets around the pulley on later versions. At high engine speeds, excess air is discharged to atmosphere through a relief valve.

A diverter valve is incorporated in the air delivery pipe between the air pump and check valve. The valve is operated by a cable on early models, or activated by a vacuum switch on later types, whenever the choke control is pulled out. During choke operation, air from the pump is cut off and diverted to atmosphere.

When the throttle is closed during deceleration or overrun, a rich fuel/air mixture is created in the inlet manifold. The gulp valve fitted between the air pump and manifold is activated by the depression also created in the manifold during these conditions, and opens to admit air from the air pump. The mixture is thus weakened preventing excessive exhaust emissions when the throttle is reopened. A restrictor is also fitted in the air feed to the gulp valve and prevents surging when the valve is in operation.

### Exhaust emission control - carburettor models with catalytic converter

From approximately 1990 onwards certain models were fitted with an unregulated or "open-loop" catalytic converter to minimise exhaust pollution. The converter consists of an element (or "substrate") of ceramic honeycomb coated with a combination of precious metals (platinum and rhodium) in such a way as to produce a vast surface area over which the exhaust gasses must flow; the

assembly being mounted in a stainless-steel box in the vehicle's exhaust system. The precious metals act as catalysts to speed up the reaction between the pollutants and the oxygen in the car's exhaust gasses. HC and



**Position a jack under the exhaust front pipe and raise it just sufficiently to hold the bellmouth tightly against the manifold flange. This will ensure that the joint is properly seated as the clamp is fitted.**

CO being oxidised to form H<sub>2</sub>O and CO<sub>2</sub>.

### Exhaust emission control - fuel injection models

All fuel-injection models are equipped with a catalytic converter in the exhaust system. The system, unlike that fitted to carburettor models, is a "closed-loop" system. The Lambda sensor in the exhaust manifold provides the engine management ECU with constant feedback on exhaust gas content, which enables the ECU to adjust the inlet fuel/air mixture to keep the converter operating at maximum efficiency.

The Lambda sensor has a built-in heating element, controlled by the ECU through the Lambda sensor relay to quickly bring the sensor's tip to an efficient operating temperature. The sensor's top is sensitive to oxygen, and sends the ECU a varying voltage

depending on the amount of oxygen in the exhaust gases; if the inlet air/fuel mixture is



**Apply liberal amounts of releasing oil to the exhaust tailpipe-to-front pipe joint if it is reluctant to come free, and allow it time to soak in.**

too rich, the exhaust gases are low in oxygen, so the sensor sends a low-voltage signal; the voltage rises as the mixture weakens and the amount of oxygen in the exhaust gases rises. Peak conversion efficiency of all major pollutants occurs if the inlet air/fuel mixture is maintained at the chemically-correct ratio for the complete combustion of petrol - 14.7 parts (by weight) of air to 1 part of fuel (the "stoichiometric" ratio). The sensor output voltage alters in a large step at this point, the ECU using the signal change as a reference point, correcting the inlet fuel/air mixture accordingly by altering the fuel injector pulse width.

## 2 Exhaust system (models without catalytic converter) - removal and refitting



### All models except Cooper S

#### Removal

1 Working in the engine compartment,

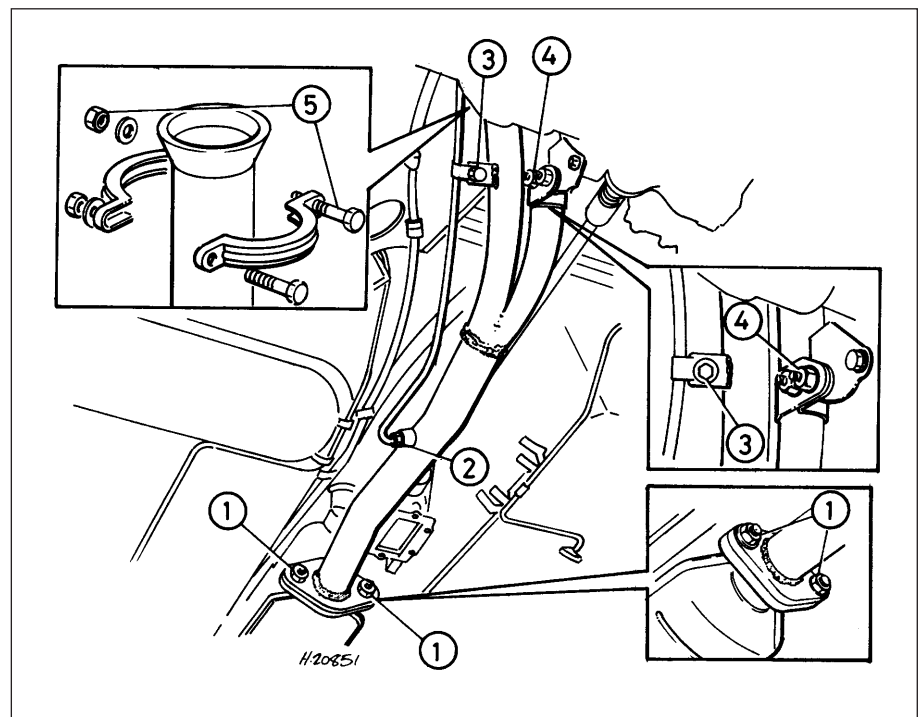

3.2 Exhaust front pipe fitted to models with catalytic converter

- |                                   |  |
|-----------------------------------|--|
| 1 Catalytic converter flange nuts | 4 Front pipe mounting nut                |
| 2 Gas sampling pipe union nut     | 5 Front pipe-to-manifold clamp and bolts |
| 3 Gas sampling pipe mounting bolt |  |

## 4C•4 Exhaust and emission control systems

remove the air cleaner (see Part A of this Chapter) and detach the throttle return spring from the bracket on the exhaust manifold clamp.

**2** Undo and remove the nuts and bolts and withdraw the manifold clamp (**see illustration**).

**3** Position the car over an inspection pit, or alternatively jack it up and support it on axle stands (see “*Jacking and vehicle support*”).

**4** From underneath the car, undo and remove the nut and bolt securing the exhaust front pipe to the transmission or transmission bracket.

**5** Now undo and remove the nuts and spring washers securing the exhaust intermediate and rear mounting brackets to the rubber blocks on the rear subframe. Slide the brackets off the studs on the rubber blocks and lower the complete system to the ground.

**6** Carefully inspect the rubber mounting blocks, the exhaust system brackets and clamps for signs of deterioration, corrosion or damage and renew as necessary.

### Refitting

**7** To refit the exhaust system, place it in position under the car and locate the brackets onto the rubber mounting blocks at the rear. Refit the nuts and spring washers but do not tighten at this stage.

**8** Before positioning the bellmouth of the front pipe over the manifold flange, smear its mating surface with sealing paste. Doing this will obviate any risk of leakage. With the help of an assistant, locate the bellmouth squarely over the flange on the manifold. Hold the system in this position and refit the manifold clamp. Ensure that the pipe is square and that the clamp is seated properly over the pipe and manifold flanges otherwise leaks will occur at this joint.

**9** Now fully tighten the manifold clamp securing bolts and refit the throttle return spring.

**10** Check that the exhaust system is clear of the subframe and floor pan over its entire length and that it is not in tension. Now fully tighten the rear mountings.

**11** Lower the car to the ground, refit the air cleaner, start the engine and check for leaks.

### Cooper S models

#### Removal

**12** Position the car over an inspection pit, or alternatively jack it up and support it on axle stands (see “*Jacking and vehicle support*”).

**13** If the rear silencer and tailpipe only are to be removed, slacken the exhaust clamp securing the rear silencer to the front pipe and then remove the retaining clip securing the tailpipe to the rear mounting. Twist the rear silencer back and forth to separate the joint and

**bellmouth tightly against the manifold flange. This will ensure that the joint is properly seated as the clamp is fitted.**

then withdraw the tailpipe from under the car.

**14** To remove the complete system, slacken the front pipe to exhaust manifold clamp, and undo and remove the bolts securing the rear mountings to the subframe. Twist the complete system back and forth to free the joint and lower it to the ground.

#### Refitting

**15** In all cases, refitting is the reverse of removal.

### 3 Exhaust system (models with catalytic converter) - removal and refitting



#### Tailpipe and silencer

##### Removal

**1** Position the car over an inspection pit, or alternatively jack it up and support it on axle stands (see “*Jacking and vehicle support*”).

**2** Slacken and remove the two nuts securing the tailpipe flange to the catalytic converter studs (**see illustration**).

**3** Either slacken and remove the nuts and bolts securing the tailpipe and silencer to its mounting brackets, or release it from its mounting rubbers (as applicable), then withdraw the assembly from underneath the car and recover the flange gasket.

##### Refitting

**4** Refitting is the reverse sequence to removal, ensuring that the flange mating surfaces are clean and free of corrosion, and using a new gasket.

#### Catalytic converter

##### Removal

**5** Remove the tailpipe and silencer assembly as described above.

**6** Unscrew the two nuts securing the catalytic converter to the front pipe, then withdraw the catalytic converter from underneath the car and recover the flange gasket.

##### Refitting

**7** Refitting is the reverse sequence to removal, ensuring that the flange mating surfaces are clean and free of corrosion and using new gaskets.

#### Front pipe

##### Removal

**8** On carburettor models, remove the air cleaner assembly (see Part A of this Chapter).

**9** Position the car over an inspection pit, or alternatively jack it up and support it on axle stands (see “*Jacking and vehicle support*”).

**10** Slacken and remove the two nuts securing the catalytic converter to the front

pipe. Unscrew the nut and bolt securing the front pipe to the bracket on the transmission.

**11** On Cooper models, undo the gas sampling pipe mounting bolts, then slacken its union nut and remove the pipe from the side of the exhaust front pipe.

**12** On all carburettor models, unbolt the exhaust front pipe-to-manifold clamp(s), then remove the front pipe from underneath the car, and recover the flange gasket from the catalytic converter.

**13** On fuel injection models, undo the three nuts securing the front pipe to the exhaust manifold, then release the pipe from the manifold and catalytic converter studs. Remove the front pipe from underneath the car, and recover the flange gaskets.

#### Refitting

**14** Refitting is the reverse sequence to removal, ensuring that the mating surfaces of the exhaust system are clean and free from corrosion. Fit a new gasket to the catalytic converter flange, and apply a smear of sealing paste to the front pipe-to-manifold joint, to alleviate any risk of leakage.

### 4 Exhaust manifold - removal and refitting



#### Carburettor models except Cooper S

**1** The exhaust manifold fitted to all carburettor models except Cooper S is removed as an assembly with the inlet manifold. Full details on this procedure will be found in Part A of this Chapter.

#### Cooper S carburettor models

##### Removal

**2** Remove the carburettors and inlet manifold as described in Part A of this Chapter.

**3** Remove the complete exhaust system as described in Section 2 of this Part.

**4** Undo and remove the nuts and flat washers securing the manifold to the cylinder head studs. Now ease the manifold off the studs and carefully manipulate it out of the engine compartment.

**5** Before removing the LCB (long centre branch) exhaust manifold, refer to Chapter 8 and detach the right-hand driveshaft at the inboard end.

**6** Refer to Chapter 10 and remove the right-hand front roadwheel, disconnect the steering tie-rod, the swivel hub at its upper and lower points, and partially withdraw the hub and driveshaft. Do not allow the assembly to hang from the brake hose.

**7** Turn the differential driving flange so that it is upright. Release the exhaust manifold from the cylinder head, manoeuvre it to the right to clear the subframe and transmission casing before easing it upwards.

##### Refitting



**Position a jack under the exhaust front pipe and raise it just sufficiently to hold the**

8 Refitting is the reverse sequence to removal, but use a new manifold gasket.

### Fuel injection models

#### Removal

9 Remove the inlet manifold as described in Part B of this Chapter.

10 Chock the rear wheels then jack up the front of the car and support it on axle stands (see "Jacking and vehicle support").

11 Working from underneath the vehicle, slacken and remove the single bolt securing the exhaust front pipe to its mounting bracket on the transmission. Undo the three nuts securing the front pipe to the exhaust manifold, and release the pipe from the manifold studs.

12 Track the wiring back from the exhaust manifold Lambda sensor, releasing it from any relevant retaining clips, and disconnect it from the main wiring harness.

13 Slacken and remove the three heat shield retaining bolts, and remove the heat shield from the manifold.

14 Undo the two remaining exhaust manifold nuts, and slide the breather pipe off the manifold stud. Disengage the manifold from its mounting studs, and remove it from the engine compartment. Remove the manifold gasket, and discard it.

15 Examine all the exhaust manifold studs for

signs of damage and corrosion; remove all traces of corrosion, and repair or renew any damaged studs.

#### Refitting

16 Refitting is the reverse sequence to removal, noting the following points:

- a) Ensure that the exhaust manifold and cylinder head mating surfaces are clean and free from corrosion, and fit a new gasket onto the manifold studs.
- b) Tighten the manifold nuts to the specified torque, not forgetting to refit the breather pipe to the left-hand stud.
- c) Fit a new gasket at the manifold to the front pipe flange joint, and securely tighten all other disturbed fasteners.

### 5 Crankcase emission control system - checking and component renewal

The crankcase emission control system consists simply of a number of ventilation hoses, an oil separator on the left-hand cylinder block side cover, or on the timing chain cover, and a wire mesh filter in the engine oil filler cap.

The components of this system require no attention other than to check that the hoses are clear and undamaged and to renew the oil

filler cap at regular intervals (see Chapter 1).

Component renewal is self-explanatory, but it may be necessary to detach surrounding components for improved access. Refer to the various Chapters of this manual as necessary if problems are encountered.

### 6 Evaporative emission control system - checking and component renewal

#### Checking

1 Poor idle, stalling and poor driveability can be caused by an inoperative canister purge valve, faulty thermostatic vacuum valve a damaged canister, split or cracked hoses, or hoses connected to the wrong fittings. Check the fuel filler cap for a damaged or deformed gasket.

2 Fuel loss or fuel odour can be caused by liquid fuel leaking from fuel lines, a cracked or damaged canister, an inoperative canister purge valve, and disconnected, misrouted, kinked or damaged vapour or control hoses.

3 Inspect each hose attached to the canister for kinks, leaks and cracks along its entire length. If their condition is suspect, disconnect each hose in turn and blow through it to check for blockages. Repair or renew as necessary.

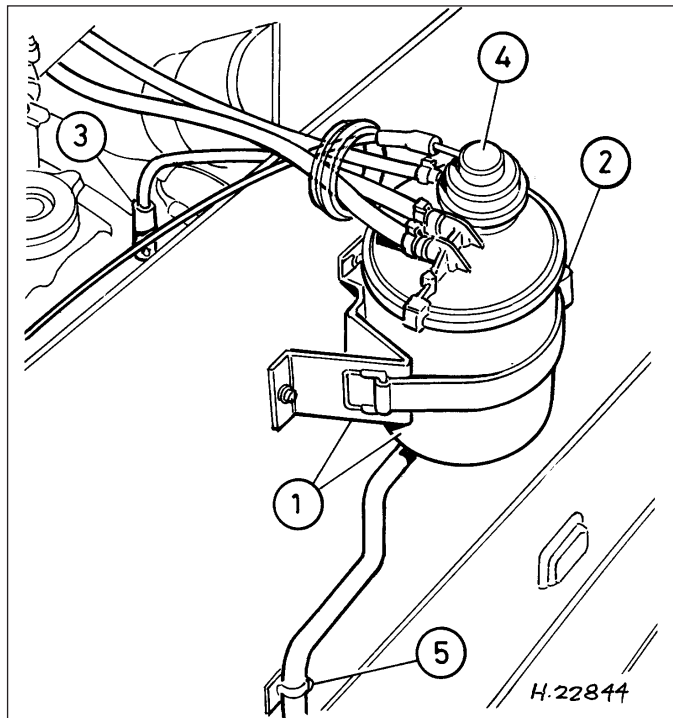

6.13 Charcoal canister fitted to carburettor models with catalytic converter

- |  |                                |
|--|--------------------------------|
| 1 Charcoal canister and mounting bracket | 4 Purge valve vacuum diaphragm |
| 2 Rubber retaining strap                 | 5 Vent hose                    |
| 3 Fuel return pipe connection            |                                |

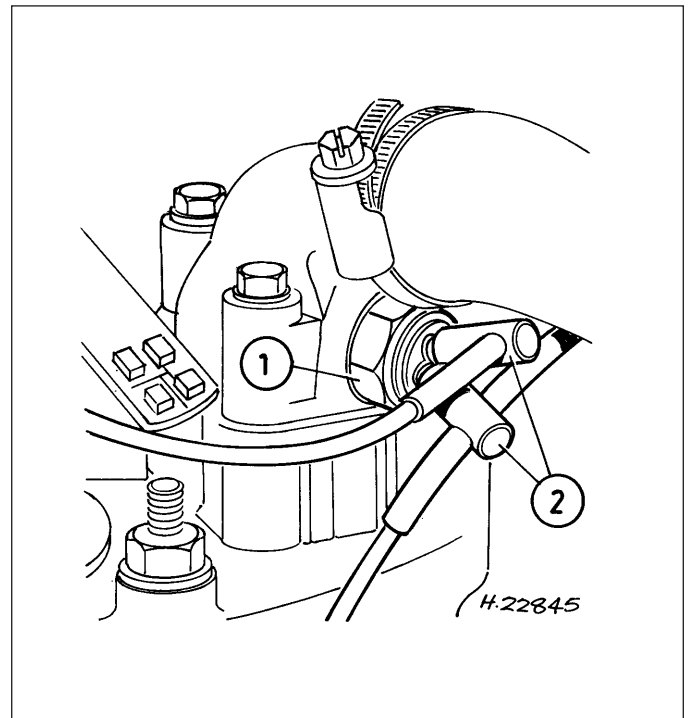

6.23 Thermostatic vacuum valve connections

- |                |                |
|----------------|----------------|
| 1 Vacuum valve | 2 Vacuum hoses |
|----------------|----------------|





**6.28** Disconnecting the purge valve wiring connector



**6.29** Release the retaining clip, and disconnect the outlet hose from the purge valve

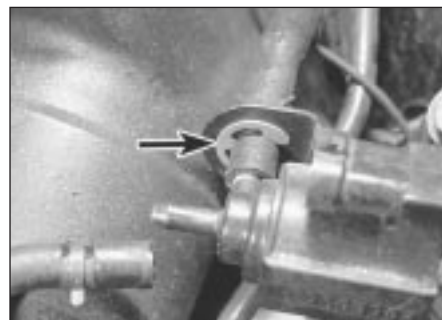

**6.30** Prise off the C-clip (arrowed), and remove the inlet hose adapter from the purge valve

**4** Inspect the canister. If it is cracked or damaged, renew it. Look for fuel leaking from the bottom of the canister. If fuel is leaking, renew the canister, and check the hoses and hose routing.

**5** Checking of the thermostatic vacuum valve and purge control valve should be entrusted to a Rover dealer.

### Component renewal

#### Charcoal canister - carburettor models

**6** Disconnect the battery negative lead.

**7** Remove the air cleaner assembly as described in Part A of this Chapter.

**8** Release the fasteners and detach the ignition cover from the front of the engine.

**9** Release the retaining clips, and disconnect the charcoal canister hoses from the side of the carburettor and from the breather hose T-piece.

**10** Disconnect the charcoal canister vacuum supply pipe from the thermostatic vacuum switch situated on the thermostat housing.

**11** Release the clip and disconnect the canister hose from the fuel return pipe.

**12** Chock the rear wheels then jack up the front of the car and support it on axle stands (see "Jacking and vehicle support").

**13** Working from underneath the left-hand wing, release the rubber retaining strap, and free the canister from its mounting bracket (see illustration). Disconnect the vacuum pipe from the purge valve diaphragm, then release the canister vent hose from the wing valance and withdraw the canister from underneath the wing.

**14** Refitting is the reverse sequence to removal, noting that if a new canister is being installed, it will be necessary to remove the vent hoses from the original canister and install them on the new one before fitting the canister to the car. Ensure that all hoses are correctly reconnected, and where necessary securely held by their retaining clips.

#### Charcoal canister - fuel injection models

**15** Disconnect the battery negative lead.

**16** Working in the engine compartment, release the retaining clip(s), and disconnect the canister hoses from the purge valve and fuel hose.

**17** Chock the rear wheels then jack up the front of the car and support it on axle stands (see "Jacking and vehicle support").

**18** From underneath the left-hand wheel arch, release the air inlet duct, and position it clear of the charcoal canister.

**19** Release the canister vent hose from its retaining clips, then release the rubber retaining strap and remove the canister and hose assembly from underneath the wheel arch.

**20** Refitting is the reverse sequence to removal, noting that if a new canister is being installed, it will be necessary to remove the vent hoses from the original canister and install them on the new one before fitting the canister to the car. Ensure that all hoses are correctly reconnected, and where necessary securely held by their retaining clips.

#### Thermostatic vacuum valve - carburettor models

**21** When the engine and radiator are cold, either drain the cooling system as described in Chapter 1, or unscrew the radiator filler cap to release any remaining pressure, and have ready a suitable plug that can be used temporarily to stop the escape of coolant while the switch is removed. If the latter method is used, take care not to damage the threads, and do not use anything which will leave foreign matter inside the cooling system.

**22** Release the fasteners and remove the ignition cover from the front of the engine.

**23** Disconnect the vacuum hoses from the thermostatic vacuum valve, which is screwed into the front of the thermostat housing (see illustration).

**24** Slacken the radiator top hose retaining clip, and slide the clip along the hose. Unscrew the valve from the front of the thermostat housing, and remove it along with its sealing washer. Where necessary, plug the housing aperture to minimise coolant loss.

**25** On refitting, apply a smear of suitable sealant to the valve threads, then refit the valve and sealing washer to the thermostat housing, tightening it to the specified torque. Slide the radiator hose retaining clip back into position, and tighten it securely.

**26** Reconnect the vacuum hoses to the valve, noting that the hose from the

carburettor must be connected to the union of the valve marked "CARB".

**27** Refit the ignition cover, and refill or top-up the cooling system as described in Chapter 1 or "Weekly Checks".

#### Purge control valve - fuel injection models

**28** Disconnect the battery negative lead, then disconnect the wiring connector from the purge control valve (see illustration).

**29** Release the retaining clips, and disconnect the inlet and outlet hoses from the valve (see illustration).

**30** Prise out the C-clip which secures the inlet hose adapter to the mounting bracket (see illustration), then withdraw the adapter, noting the O-ring which is fitted between the adapter and purge valve. Discard the O-ring; it must be renewed as a matter of course.

**31** Slide the purge valve out of its mounting bracket, and remove the valve from the car.

**32** Refitting is the reverse sequence to removal, using a new inlet hose adapter O-ring.

#### Fuel tank breather two-way valve - fuel injection models

**33** Remove the fuel tank as described in Part B of this Chapter.

**34** Release the retaining clip, and disconnect the two-way breather valve vent hose from the fuel tank. Unclip the valve and hose assembly from the tank seam, and remove it.

**35** Release the retaining clips, disconnect the hose from the valve, then undo the two retaining nuts, and separate the valve from the mounting bracket.

**36** Refitting is the reverse sequence to removal, tightening the valve retaining nuts to the specified torque, and ensuring that the hoses are securely reconnected.

## 7 Exhaust emission control system - checking and component renewal



**Note:** The following procedures apply to those models **without** a catalytic converter.

### Checking

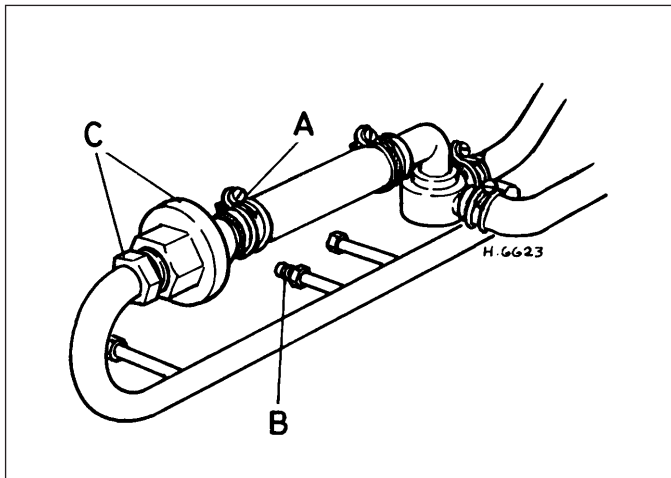

**7.18 Air manifold assembly fitted to early models without catalytic converter**

A Check valve hose clip  
B Air manifold unions

C Check valve and union nut

1 Checking of the system as a whole entails a close visual inspection of all hoses, pipes and connections for condition and security. Ensure also that the air pump drivebelt is in satisfactory condition and correctly tensioned as described in Chapter 1.

#### Air pump and air manifold

2 Check the condition of the air pump bearings with the drivebelt removed by moving the pulley from side to side. Any appreciable movement indicates wear and will usually be accompanied by excessive noise from the unit when in operation. Apart from this, any known or suspected faults on either of these components should be attended to by a Rover dealer.

#### Check valve

3 Remove the valve as described later in this Section and test it by gently blowing into each end in turn. Air should pass through the valve from the air supply end only. If air will pass in both directions the valve is faulty and must be renewed. Do not use high pressure air or air from a tyre pump for this check or the valve will be damaged.

#### Vacuum operated diverter valve

4 To test the operation of the valve, slacken the hose clip and detach the diverter valve-to-check valve hose at the check valve end.

5 Start the engine and allow it to idle. Air pressure should be felt at the end of the disconnected hose.

6 Operate the choke control, and air pressure at the disconnected hose should be cut off completely. If air can still be felt at the end of the hose, the diverter valve is faulty and should be renewed.

#### Cable operated diverter valve

7 The procedure for testing the cable operated diverter valve is the same as for the vacuum type described previously. If the valve does not completely restrict the flow of air

when the choke control is operated, make sure that the cable is correctly adjusted as described later in this Section and then carry out the test again. If the airflow is still not completely restricted, renew the valve.

#### Gulp valve

8 This component can only be tested satisfactorily using vacuum gauges. If the valve is suspect it is recommended that the testing is carried out by a Rover dealer.

### Component renewal

#### Air pump

9 Remove the air pump drivebelt as described in Chapter 1.

10 Slacken the clips and detach the outlet hoses from the pump adapter.

11 Detach the HT lead and undo and remove No 1 cylinder spark plug.

12 Slacken the bolt securing the pump adjusting arm to the alternator pivot bolt.

13 Undo and remove the bolt securing the adjusting arm to the air pump.

14 Undo and remove the air pump pivot nut and bolt and lift off the pump.

15 Refitting is the reverse sequence to removal. Ensure that the drivebelt is correctly tensioned as described in Chapter 1.

#### Air manifold

16 Release the three retaining lugs and remove the engine ignition shield, if fitted.

17 Detach the HT lead from No 1 cylinder spark plug.

18 Undo and remove the four air manifold unions from the cylinder head (see illustration).

19 Slacken the clip securing the check valve hose and lift away the air manifold complete with check valve.

20 Hold the air manifold union with a spanner and unscrew the check valve.

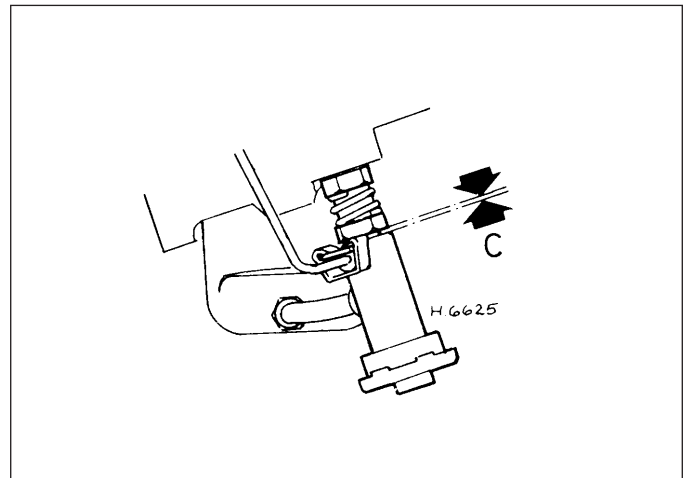

**7.32 Correct position of jet assembly when testing diverter valve operation**

C = 0.25 to 0.38 mm

21 Refitting is the reverse sequence to removal.

#### Check valve

22 Slacken the retaining clip and detach the hose from the check valve.

23 Hold the air manifold union to prevent it twisting and unscrew the check valve.

24 Refitting the check valve is the reverse sequence to removal.

#### Vacuum operated diverter valve

25 Slacken all the hose clips and detach the three air hoses and the small vacuum hose from the valve body.

26 Undo and remove the two retaining nuts and bolts and lift the valve off its mounting bracket.

27 Refitting is the reverse sequence to removal.

#### Cable operated diverter valve

28 Slacken the cable retaining screw and slide the cable and retainer out of the valve operating lever.

29 Slacken the hose clips and detach the three hoses from the valve body, then lift the valve off the engine.

30 Refitting the valve is the reverse sequence



**8.4 Disconnecting the exhaust system Lambda sensor wiring connector**

to removal. With the valve installed adjust the operating cable as follows.

**31** Observe the movement of the jet housing beneath the carburettor while an assistant slowly operates the choke control.

**32** When the jet housing has moved down away from the adjusting nut by 0.25 to 0.38 mm, lock the choke control to hold it in this position (**see illustration**).

**33** The clearance between the diverter valve operating lever and the valve stem should now be 0.04 to 0.08 mm. Adjust the position of the cable retainer to obtain this dimension.

### Gulp valve

**34** To remove the gulp valve slacken all the hose clips, and detach the air hoses and the vacuum hose from the valve body.

**35** Undo and remove the two retaining nuts and bolts and lift the valve off its mounting

bracket.

**36** Refitting is the reverse sequence to removal.

## 8 Exhaust emission control system - checking and component renewal



**Note:** *The following procedures apply to those models with a catalytic converter.*

### Checking

**1** Checking of the system as a whole entails a close visual inspection of all hoses, pipes and connections for condition and security. High exhaust gas CO content on carburettor models may be due to other fuel or ignition system faults such as dirty or choked air cleaner element, worn or incorrectly adjusted

carburettor, worn or badly adjusted spark plugs or incorrect ignition timing. Apart from these checks, and checks of the general engine condition, any known or suspected faults in the exhaust emission control system should be attended to by a Rover dealer.

### Component renewal

#### Catalytic converter

**2** Removal and refitting procedures for the catalytic converter are contained in Section 3; general information and precautions are contained in Section 9.

#### Lambda sensor - fuel injection models

**Note:** *The Lambda sensor is delicate, and will not work if it is dropped or knocked, if its power supply is disrupted, or if any cleaning materials are used on it.*

**3** Remove the inlet manifold as described In





# Chapter 5 Part A:

## Starting and charging systems

### Contents

Alternator - removal and refitting . . . . .	10	Dynamo - removal and refitting . . . . .	6
Alternator brushes - renewal . . . . .	11	Dynamo brushes - renewal . . . . .	7
Alternator charging system - testing . . . . .	9	Dynamo charging system - testing . . . . .	5
Battery - removal and refitting . . . . .	4	Electrical fault finding - general information . . . . .	2
Battery - testing and charging . . . . .	3	Fan belt check and renewal . . . . .	See Chapter 1
Battery, bulbs and fuses . . . . .	See "Weekly Checks"	General information and precautions . . . . .	1
Control box - adjustment . . . . .	8	Starter motor - removal and refitting . . . . .	13
Control box cleaning and inspection . . . . .	See Chapter 1	Starter motor - testing and overhaul . . . . .	14
Drive pinion assembly (inertia type starter) - removal and refitting . . . . .	15	Starter solenoid - removal and refitting . . . . .	16
Dynamo check and lubrication . . . . .	See Chapter 1	Starting system - testing . . . . .	12

### Degrees of difficulty

<b>Easy</b> , suitable for novice with little experience		<b>Fairly easy</b> , suitable for beginner with some experience		<b>Fairly difficult</b> , suitable for competent DIY mechanic		<b>Difficult</b> , suitable for experienced DIY mechanic		<b>Very difficult</b> , suitable for expert DIY or professional	
--	---	---	---	---	---	--	---	---	---

### Specifications

<b>System type</b> . . . . .	12-volt, negative earth
<b>Battery</b>	
Type . . . . .	Low maintenance or "maintenance-free" sealed for life
Capacity . . . . .	30 to 50 amp hour at 20 hour rate
Charge condition:	
Poor . . . . .	12.5 volts
Normal . . . . .	12.6 volts
Good . . . . .	12.7 volts
<b>Dynamo</b>	
Type . . . . .	Lucas C40/1
Maximum output . . . . .	22 amps at 2250 rpm
Cut-in speed . . . . .	1450 rpm at 13.5 volts
Minimum brush length . . . . .	12.7 mm
Brush spring tension . . . . .	510 g
<b>Control box</b>	
Type . . . . .	Lucas RB106/2
Regulator:	
Open circuit setting at 3000 rpm (dynamo speed) at 20°C (68°F) . . . . .	16.0 to 16.6 volts, decreasing by 0.1 volt for every increase of 10°C (18°F) above 20°C (68°F)
Cut-out:	
Cut-in voltage . . . . .	12.7 to 13.3 volts
Drop-off voltage . . . . .	8.5 to 11 volts
Reverse current . . . . .	5.0 amps (maximum)



### Alternator

Type:	
Pre-1982 models	Lucas 11AC or 16ACR
1982 to 1985 models	Lucas A115
1986 models onward	Lucas A127/45 or A127/55
Maximum output:	
11AC	43 amps
16ACR	34 amps
A115 and A127/45	45 amps
A127/55	55 amps
Minimum brush length:	
11AC	3.9 mm
16ACR	7.5 mm
A115	10.0 mm
A127/45 and A127/55	5.0 mm

### Starter motor

Type:	
Pre-1986 models	Lucas M35G or M35J (inertia type)
1986 models onward	Lucas M79 (pre-engaged type)
Minimum brush length:	
M35G and M35J	8.0 mm
M79	3.5 mm
Brush spring tension:	
M35G	425 to 710 g
M35J	794 g
M79	N/A

## 1 General information and precautions

### General information

The engine electrical system consists mainly of the charging and starting systems. Because of their engine-related functions, these components are covered separately from the body electrical devices such as the lights, instruments, etc (which are covered in Chapter 12). Information on the ignition system is covered in Part B of this Chapter.

The electrical system is of the 12-volt negative earth type.

The battery is of the low maintenance or "maintenance-free" (sealed for life) type and is charged by the dynamo or alternator, which is driven by the fan belt.

The charging system on early models consists of a dynamo and control box incorporating a voltage regulator and cut-out. The voltage regulator controls the output from the dynamo depending on the state of the battery and the demands of the electrical equipment, and ensures that the battery is not over-charged. The cut-out is really an automatic switch and connects the dynamo to the battery when the dynamo is turning fast enough to produce a charge. Similarly it disconnects the battery from the dynamo when the engine is idling or stationary so that the battery does not discharge through the dynamo.

Later models are equipped with an alternator in place of the dynamo and control box. The Lucas 11AC alternator and separate 4TR control unit was used initially, but has

been superseded by the 16ACR, A115 and A127 alternators with integral control units.

The alternators are all similar in construction, comprising basically an aluminium casing, housing a three-phase star connected stator. A rotor carrying the field windings rotates within the stator and is driven by the fan belt. The alternator output is controlled by a voltage regulator located in the separate control unit on the 11AC alternator and contained within the end housing on the other machines.

As its name implies, the alternator generates alternating current (ac) as opposed to direct current (dc) generated by the dynamo. The alternating current is rectified by diodes, located in the alternator end housing, into direct current, which is the current required for battery charging.

On early models an inertia type starter motor is fitted energised by a separate solenoid switch mounted on the front inner wing panel. When the ignition switch is turned, current flows from the battery to the starter motor solenoid, which causes it to become energised. Its internal plunger moves inwards and closes an internal switch, so allowing full starting current to flow from the battery to the starter motor. This causes a powerful magnetic field to be induced into the field coils which causes the armature to rotate.

Mounted on helical splines is the drive pinion which, because of the sudden rotation of the armature, is thrown forwards along the armature shaft and so into engagement with the ring gear. The engine crankshaft will then be rotated until the engine starts to operate on its own and, at this point, the drive pinion is thrown out of mesh with the ring gear.

A pre-engaged type starter motor is fitted to all models from 1986 onward. On starting, the integral solenoid moves the drive pinion into engagement with the flywheel ring gear before the starter motor is energised. Once the engine has started, a one-way clutch prevents the motor armature being driven by the engine until the pinion disengages from the flywheel.

### Precautions

Further details of the various systems are given in the relevant Sections of this Chapter. While some repair procedures are given, the usual course of action is to renew the component concerned. The owner whose interest extends beyond mere component renewal should obtain a copy of the "Automobile Electrical & Electronic Systems Manual", available from the publishers of this manual.

It is necessary to take extra care when working on the electrical system to avoid damage to semi-conductor devices (diodes and transistors), and to avoid the risk of personal injury. In addition to the precautions given in "Safety first!" at the beginning of this manual, observe the following when working on the system:

*Always remove rings, watches, etc before working on the electrical system.* Even with the battery disconnected, capacitive discharge could occur if a component's live terminal is earthed through a metal object. This could cause a shock or nasty burn.

*Do not reverse the battery connections.* Components such as the alternator, electronic control units, or any other components having semi-conductor circuitry could be irreparably damaged.

If the engine is being started using jump leads and a slave battery, connect the batteries *positive-to-positive* and *negative-to-negative* (see "Jump starting"). This also applies when connecting a battery charger.

Never disconnect the battery terminals, the alternator, any electrical wiring or any test instruments when the engine is running.

Do not allow the engine to turn the alternator when the alternator is not connected.

Never "test" for alternator output by "flashing" the output lead to earth.

Never use an ohmmeter of the type incorporating a hand-cranked generator for circuit or continuity testing.

Always ensure that the battery negative lead is disconnected when working on the electrical system.

Before using electric-arc welding equipment on the car, disconnect the battery, alternator and components such as the fuel injection/ignition electronic control unit to protect them from the risk of damage.

The radio/cassette units fitted as standard or optional equipment to later models may be equipped with a built-in security code to deter thieves. If the power source to the unit is cut, the anti-theft system will activate. Even if the power source is immediately reconnected, the radio/cassette unit will not function until the correct security code has been entered. Therefore, if you do not know the correct security code for the radio/cassette unit **do not** disconnect the negative terminal of the battery or remove the radio/cassette unit from the car. Refer to the Owner's Manual, or your Rover dealer for further information on security codes.

## 2 Electrical fault finding - general information

Refer to Chapter 12.

## 3 Battery - testing and charging

### Standard and low maintenance battery - testing

**1** If the vehicle covers a small annual mileage, it is worthwhile checking the specific gravity of the electrolyte every three months to determine the state of charge of the battery. Use a hydrometer to make the check and compare the results with the following table.

**Ambient temperature 25°C (77°F):**

	above	below
Fully-charged	1.210 to 1.230	1.270 to 1.290
70% charged	1.170 to 1.190	1.230 to 1.250
Fully-discharged	1.050 to 1.070	1.110 to 1.130

Note that the specific gravity readings assume an electrolyte temperature of 15°C (60°F); for every 10°C (18°F) below 15°C (60°F) subtract 0.007. For every 10°C (18°F) above 15°C (60°F) add 0.007.

**2** If the battery condition is suspect, first check the specific gravity of electrolyte in each cell. A variation of 0.040 or more between any cells indicates loss of electrolyte or deterioration of the internal plates.

**3** If the specific gravity variation is 0.040 or more, the battery should be renewed. If the cell variation is satisfactory but the battery is discharged, it should be charged as described later in this Section.

### Maintenance-free battery - testing

**4** In cases where a "sealed for life" maintenance-free battery is fitted, topping-up and testing of the electrolyte in each cell is not possible. The condition of the battery can therefore only be tested using a battery condition indicator or a voltmeter.

**5** If testing the battery using a voltmeter, connect the voltmeter across the battery and compare the result with those given in the *Specifications* under "charge condition". The test is only accurate if the battery has not been subjected to any kind of charge for the previous six hours. If this is not the case, switch on the headlights for 30 seconds, then wait four to five minutes before testing the battery after switching off the headlights. All other electrical circuits must be switched off, so check that the doors and tailgate are fully shut when making the test.

**6** If the voltage reading is less than 12.2 volts, then the battery is discharged, whilst a reading of 12.2 to 12.4 volts indicates a partially discharged condition.

**7** If the battery is to be charged, remove it from the vehicle (Section 4) and charge it as described later in this Section.

### Standard and low maintenance battery - charging

**Note:** *The following is intended as a guide only. Always refer to the manufacturer's recommendations (often printed on a label attached to the battery) before charging a battery.*

**8** Charge the battery at a rate of 3.5 to 4 amps and continue to charge the battery at this rate until no further rise in specific gravity is noted over a four hour period.

**9** Alternatively, a trickle charger charging at the rate of 1.5 amps can safely be used overnight.

**10** Specially rapid "boost" charges which are claimed to restore the power of the battery in 1 to 2 hours are not recommended, as they can cause serious damage to the battery plates through overheating.

**11** While charging the battery, note that the temperature of the electrolyte should never exceed 37.8°C (100°F).

### Maintenance-free battery - charging

**Note:** *The following is intended as a guide only. Always refer to the manufacturer's recommendations (often printed on a label attached to the battery) before charging a battery.*

**12** This battery type takes considerably longer to fully recharge than the standard type, the time taken being dependent on the extent of discharge, but it can take anything up to three days.

**13** A constant voltage type charger is required, to be set, when connected, to 13.9 to 14.9 volts with a charger current below 25 amps. Using this method, the battery should be usable within three hours, giving a voltage reading of 12.5 volts, but this is for a partially discharged battery and, as mentioned, full charging can take considerably longer.

**14** If the battery is to be charged from a fully discharged state (condition reading less than 12.2 volts), have it recharged by your Rover dealer or local automotive electrician, as the charge rate is higher and constant supervision during charging is necessary.

## 4 Battery - removal and refitting

### Removal

**Note:** *Make sure that you have a copy of the radio/cassette unit security code number (where applicable) before disconnecting the battery.*

**1** The battery is located in a recess in the right-hand side of the luggage compartment floor on Saloon models, beneath the rear seat on Estate models, and behind the passenger seat on the Van and Pick-up.

**2** Remove the cover (where fitted) then disconnect the negative and then the positive leads from the battery after first removing the retaining screws or nuts and bolts from the terminal posts (**see illustration**).

**3** Remove the battery clamp and carefully lift the battery out of its compartment. Hold the battery upright to ensure that none of the electrolyte is spilled.

### Refitting

**4** Refitting is a direct reversal of this procedure. **Note:** *Refit the positive lead before the negative lead and smear the terminals with petroleum jelly. Never use an ordinary grease.*



4.2 Disconnecting the battery negative lead (Saloon model shown)

### 5 Dynamo charging system - testing



**Note:** Refer to the warnings given in "Safety first!" and in Section 1 of this Chapter before starting work.

**1** If the ignition warning light fails to go out with the engine running, or if the battery does not appear to be receiving a charge, the dynamo may be at fault and should be tested while still in position on the engine as follows.

**2** First check the fan belt condition and adjust the tension if necessary (see Chapter 1).

**3** Check the leads from the dynamo to the control box (D and F), ensuring that they are firmly attached and that one has not come loose from its terminal.

**4** To test the dynamo, first ensure that all electrical equipment is switched off and then pull the leads off the two dynamo terminals. Now join the two dynamo terminals together using a short length of non-insulated wire.

**5** Attach to the centre of this short length of wire the positive clip of a 0 to 20 volt voltmeter. Connect the negative clip of the voltmeter to a good earth on the dynamo yoke.

**6** Start the engine and allow it to run at a fast idle. A reading of approximately 15 volts should now be indicated on the voltmeter. If no reading is recorded, it is quite likely that the dynamo brushes or brush connections are at fault. If a very low reading is observed then the field windings or armature may be suspect.

**7** Brush renewal is described in Section 7; any other repair should be entrusted to an auto electrician who will be able to determine if repair is feasible, or whether an exchange reconditioned unit should be obtained.

**8** If the voltmeter readings are satisfactory, switch off the engine and disconnect the voltmeter. With the temporary link still in position, reconnect the two leads to the dynamo terminals and then disconnect the D and F terminals at the control box. Connect the positive clip of the voltmeter to the D lead and the negative clip to earth. Start the engine and allow it to run at a fast idle. The reading on the voltmeter should be identical to that recorded at the dynamo. If no voltage is recorded there is a break in the wire. If the voltage is less than previously recorded check the terminals for corrosion and the wire for chafing. Test the F lead in a similar fashion. If both readings are the same as recorded at the dynamo, then it will be necessary to test the control box as described in Section 8.

**9** On completion of the tests remove the temporary link from the dynamo terminals and reconnect the leads to the dynamo and control box.

### 6 Dynamo - removal and refitting



#### Removal

**1** Disconnect the battery negative lead.

**2** Slacken the two dynamo upper retaining bolts and the nut on the adjustment arm. Move the dynamo towards the engine and lift the fan belt off the pulley.

**3** Disconnect the two leads from the dynamo terminals. If the ignition coil is mounted on the dynamo, slide back the rubber cover and disconnect the high tension lead from the centre of the coil, followed by the two low tension leads (see illustration).

**4** Undo and remove the lower bolt securing the adjustment arm to the dynamo and remove the two upper retaining bolts, nuts and washers. The dynamo can now be lifted off the engine.

#### Refitting

**5** Refitting the dynamo is the reverse sequence to removal, ensuring that the fan belt is correctly tensioned as described in Chapter 1 before fully tightening the retaining bolts.

**6** If a new or exchange dynamo is being fitted, ensure that the unit is correctly polarised as described below before installing.

**7** In order for the dynamo to function it must be correctly polarised to suit the electrical installation to which it is being fitted. To polarise the dynamo to suit a negative earth system, connect a suitable length of wire from the battery earth terminal to the dynamo yoke or end bracket. Now connect another length of wire to the battery positive terminal and flick the other end of the wire several times on the dynamo F (small) terminal. This will induce a magnetism of the correct polarity into the dynamo field windings.

**8** The correctly polarised dynamo can now be fitted to the car.

### 7 Dynamo brushes - renewal



**1** Remove the dynamo from the car as described in Section 6.

**2** If the ignition coil is mounted on the dynamo, undo and remove the clamp retaining bolts and lift off the coil.

**3** Undo and remove the two long screws from the rear of the dynamo and lift off the commutator end bracket.

**4** Now lift out the armature complete with drive end bracket and pulley from the dynamo yoke.

**5** Undo and remove the brush lead retaining screws and lift the brushes out of their holders. If the brushes have worn to less than the minimum specified length, they must be renewed.

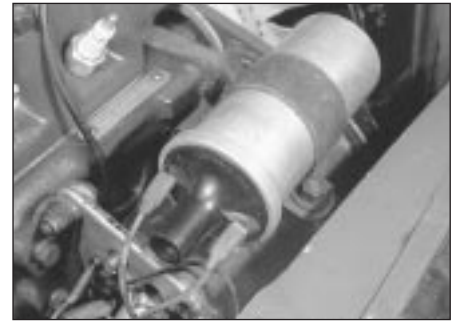

**6.3 Disconnecting the coil leads**

**6** Check that the brushes slide freely and easily in their holders. If either of the brushes has a tendency to stick, clean the brushes with methylated spirit and a clean rag. If still stiff, lightly polish the sides of the brush with a very fine file until the brush moves quite freely and easily in its holder.

**7** If the brushes are in a satisfactory condition and are to be re-used, ensure that they are refitted in the same holders from which they were removed. Check the tension of the brush springs using a small spring balance if possible. If the tension is insufficient, renew the springs.

**8** Check the condition of the commutator. If the surface is dirty or blackened, clean it with methylated spirit and a clean rag. If the commutator is in good condition, the surface will be smooth and quite free from pits or burnt areas, and the insulated segments clearly defined. If the commutator is severely worn, seek the advice of an auto electrician as to whether reconditioning is possible. Alternatively obtain a reconditioned dynamo.

**9** If, after the commutator has been cleaned, pits and burnt spots are still present, then wrap a strip of glass paper round the commutator and rotate the armature.

**10** Reassemble the dynamo using the reverse of the dismantling procedure. When refitting the commutator end bracket ease back the springs and lift the brushes half way out of their holders. Now rest the spring against the side of the brush to hold it in this position. This will prevent the brushes from fouling the commutator as the end bracket is fitted. With the end bracket in place, push the brushes down into contact with the commutator using a screwdriver inserted through the openings in the end bracket. As this is done the springs will jump into their correct position over the brushes.

### 8 Control box - adjustment



**Note:** Refer to the warnings given in "Safety first!" and in Section 1 of this Chapter before starting work.

**1** If the battery and dynamo are in sound condition but the operation of the charging circuit is still suspect, then the voltage

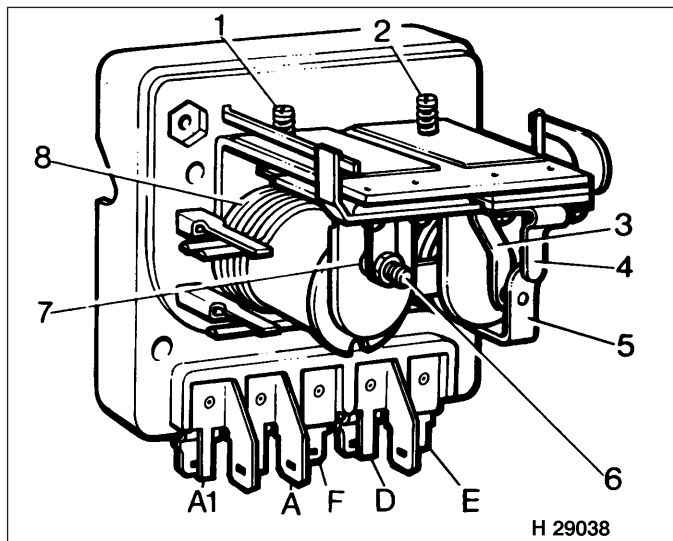

8.2 Control box components

- |                           |                                      |
|---------------------------|--------------------------------------|
| 1 Voltage adjusting screw | 5 Armature tongue and moving contact |
| 2 Cut-out adjusting screw | 6 Regulator fixed contact screw      |
| 3 Fixed contact blade     | 7 Regulator moving contact           |
| 4 Stop arm                | 8 Regulator series windings          |

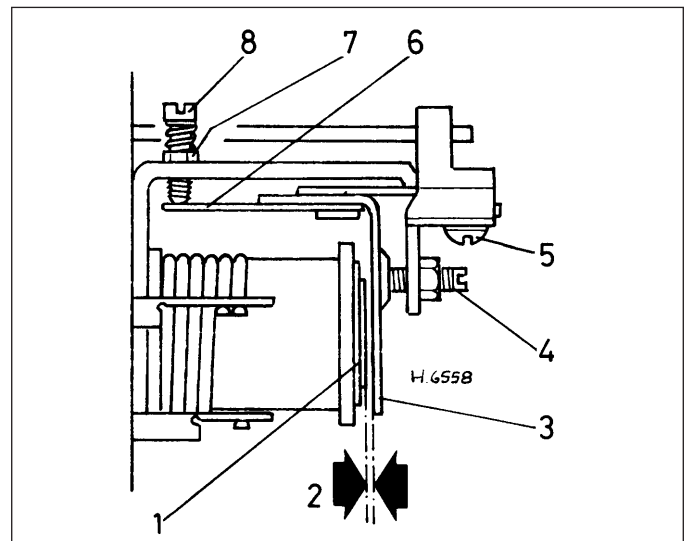

8.4 Mechanical setting of regulator

- |                                  |                            |
|----------------------------------|----------------------------|
| 1 Core face and shim             | 5 Armature securing screws |
| 2 0.533 mm                       | 6 Armature tension spring  |
| 3 Armature                       | 7 Locknut                  |
| 4 Fixed contact adjustment screw | 8 Voltage adjusting screw  |

regulator and cut-out in the control box should be checked, and if necessary adjusted as follows.

### Voltage regulator adjustment

**2** Check the regulator settings by removing the leads A and A1 from the control box and joining them together using a short length of wire (see illustration). Connect the positive clip of a 0 to 20 volt voltmeter to the D terminal of the control box, and the negative clip to a good earth.

**3** Start the engine and slowly increase its speed until the voltmeter needle flicks and then steadies. This should occur at about 2000 rpm.

**4** If the voltage at which the needle steadies is outside the limits listed in the table, switch off the engine, remove the control box cover and turn the regulator adjusting screw a fraction of a turn at a time, clockwise to increase the setting and anti-clockwise to decrease it (see illustration). Recheck the voltage reading after each adjustment.

Air temperature	Open circuit voltage
10°C (50°F)	16.1 to 16.7
20°C (68°F)	16.0 to 16.6
30°C (86°F)	15.9 to 16.5
40°C (104°F)	15.8 to 16.4

It is essential that the adjustments be completed within 30 seconds of starting the engine otherwise the heat from the shunt coil will affect the readings.

### Cut-out adjustment

**5** With the control box A and A1 leads joined together, and the voltmeter connected as described in paragraph 2, the cut-in voltage can be checked, and if necessary adjusted, as follows.

**6** Switch on the headlights to provide an electrical load, start the engine and slowly increase its speed. The voltage reading will rise steadily, drop back and then rise again. The point reached just before the drop back should be between 12.7 and 13.3 volts.

**7** If the reading obtained is outside these limits, switch off the engine and turn the cut-out adjusting screw a fraction of a turn at a time clockwise to raise the voltage and anti-clockwise to lower it (see illustration). Recheck the voltage reading after each adjustment. As with the voltage regulator, it is essential that the adjustments be completed within 30 seconds of starting the engine, otherwise the heat from the shunt coil will affect the readings.

**8** After completing the adjustments remove the voltmeter, disconnect the control box leads and refit the cover.

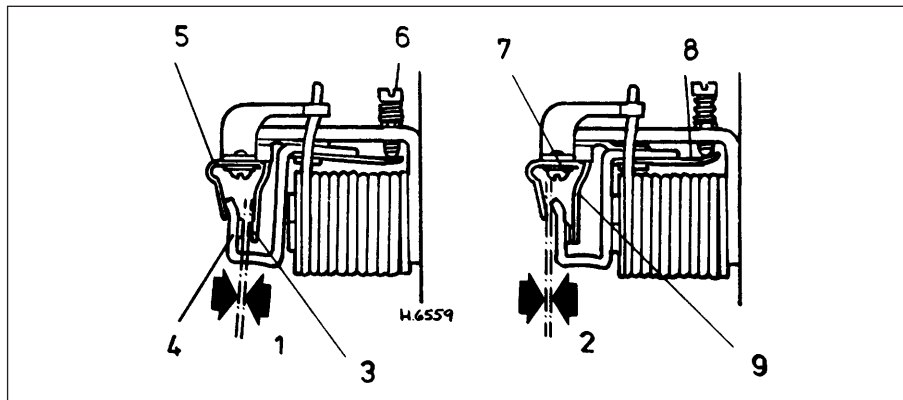

8.7 Mechanical setting of cut-out

- |                                      |                           |
|--------------------------------------|---------------------------|
| 1 0.25 to 0.51 mm                    | 6 Output adjusting screw  |
| 2 0.76 mm                            | 7 Armature securing screw |
| 3 Follow through - 0.25 to 0.51 mm   | 8 Armature tension spring |
| 4 Armature tongue and moving contact | 9 Fixed contact blade     |
| 5 Stop arm                           |                           |



## 9 Alternator charging system - testing



**Note:** Refer to the warnings given in “Safety first!” and in Section 1 of this Chapter before starting work.

**1** If the ignition warning light fails to illuminate when the ignition is switched on, first check the alternator wiring connections for security. If satisfactory, check that the warning light bulb has not blown, and that the bulbholder is secure in its location in the instrument panel. If the light still fails to illuminate, check the continuity of the warning light feed wire from the alternator to the bulbholder. If all is satisfactory, the alternator is at fault and should be renewed or taken to an auto-electrician for testing and repair.

**2** If the ignition warning light illuminates when the engine is running, stop the engine and check that the fan belt is correctly tensioned (see Chapter 1) and that the alternator connections are secure. If all is so far satisfactory, check the alternator brushes as described in Section 11. If the fault persists, the alternator should be renewed, or taken to an auto-electrician for testing and repair.

**3** If the alternator output is suspect even though the warning light functions correctly, the regulated voltage may be checked as follows.

**4** Connect a voltmeter across the battery terminals and start the engine.

**5** Increase the engine speed until the voltmeter reading remains steady; the reading should be approximately 12 to 13 volts, and no more than 14 volts.

**6** Switch on as many electrical accessories (eg, the headlights, heated rear window and heater blower) as possible, and check that the alternator maintains the regulated voltage at around 13 to 14 volts.

**7** If the regulated voltage is not as stated, the fault may be due to worn brushes, weak brush springs, a faulty voltage regulator, a faulty diode, a severed phase winding or worn or damaged slip rings. The brushes may be checked as described in Section 11, but if the fault persists, the alternator should be renewed or taken to an auto-electrician for testing and repair.

## 10 Alternator - removal and refitting



### Removal

**Note:** If working on a pre-1990 car fitted with exhaust emission control equipment, it will be necessary to remove the air pump and drivebelt as described in Chapter 4C to provide access to the alternator.

**1** On models fitted with an ignition shield over

the front of the engine release the three retaining lugs and lift off the shield.

**2** Release the spring clip and disconnect the wiring connector from the rear of the alternator.

**3** Slacken the alternator adjusting arm nut and the bolt securing the adjusting arm to the alternator.

**4** Slacken the two upper mounting nuts and bolts, move the alternator toward the engine and slip the fan belt off the pulley.

**5** Remove the two upper mounting nuts and bolts and the bolt securing the adjusting arm to the alternator. Lift the alternator off the engine.

### Refitting

**6** Refitting is the reverse sequence to removal. Ensure that the fan belt is correctly tensioned as described in Chapter 1 before finally tightening the mounting and adjustment arm bolts.

## 11 Alternator brushes - renewal



### 11AC alternator

**1** Remove the alternator from the car as described in Section 10.

**2** To remove the brushes, undo and remove the nut and spring washer, the large Lucar terminal and the plastic strip from the output terminal.

**3** Undo and remove the two securing screws and withdraw the brush box. Note that there are two small washers between the brush box and end bracket.

**4** Close up the retaining tongue at the root of each terminal blade and withdraw the brush, spring and terminal assemblies from the brush box.

**5** With the brushes removed, measure their length, and renew them if worn to less than the minimum specified length.

**6** Check that the brushes slide smoothly in their holders. Any sticking tendency may first be rectified by wiping with methylated spirit and a clean cloth, or if this fails, by carefully polishing with a very fine file where any binding marks may appear.

**7** Refitting the brushes is the reverse sequence to removal. When refitting the terminal blades to the brush box bend the retaining tongue, at the root of each blade, out slightly to retain the blade in position.

### 16ACR alternator

**8** Remove the alternator from the car as described in Section 10.

**9** Undo and remove the two retaining screws and lift off the moulded end cover.

**10** Detach the cable from the terminal blade on the outer of the three rectifier plates. Also detach the cable from the blade between the middle and inner of the three rectifier plates.

**11** Undo and remove the four screws securing the brush assemblies to the brush holder.

**12** Undo and remove the screw securing the surge protection diode cable to the brush holder.

**13** Finally undo and remove the three bolts and lift off the brush holder and regulator assembly. Note that there is a small leaf spring fitted at the side of the inner brush.

**14** Check the condition of the brushes as described in paragraphs 5 and 6.

**15** Refitting the brushes is the reverse sequence to removal.

### A115 alternator

**16** Remove the alternator as described in Section 10.

**17** Disconnect and remove the interference suppression capacitor from the end cover.

**18** Undo the screws or nuts which secure the end cover, and remove the cover.

**19** Unscrew the surge protection diode securing screw. Either move the diode carefully out of the way, or disconnect it from the rectifier board and remove it.

**20** Make a careful note of the regulator lead colours and fitting arrangements, then disconnect the regulator leads from the rectifier board and remove it.

**21** Remove the regulator screw and withdraw the regulator. Note that the regulator securing screw also holds one of the brush mounting plates in position.

**22** Remove the two securing screws, and withdraw the brushbox. Extract the free brush, then undo the securing screw to release the other brush. Remove the sealing pad.

**23** Renew the brushes if they are at, or approaching, the minimum specified length. Check the brush spring pressure with the brush ends flush with the end of the brushbox; renew the springs if they have become weak.

**24** Refitting the brushes is the reverse sequence to removal.

### A127 alternator

**25** Remove the alternator as described in Section 10.

**26** Undo the three small screws securing the regulator and brushbox assembly to the rear of the alternator.

**27** Tip the assembly upwards at the edge, and withdraw it from its location. Disconnect the rectifier wiring connection, and remove the regulator and brushbox.

**28** Measure the brush length, and renew the regulator and brushbox assembly if the brushes are worn below the figure given in the *Specifications*.

**29** Refitting the brushes is the reverse sequence to removal.

## 12 Starting system - testing



**Note:** Refer to the precautions given in "Safety first!" and in Section 1 of this Chapter before starting work.

1 If the starter motor fails to operate when the ignition key is turned to the appropriate position, the following possible causes may be to blame.

- The battery is faulty.
- The electrical connections between the switch, solenoid, battery and starter motor are somewhere failing to pass the necessary current from the battery through the starter to earth.
- The solenoid is faulty.
- The starter motor drive pinion may be jammed in the flywheel ring gear teeth (inertia type starters).
- The starter motor is mechanically or electrically defective.

2 To check the battery, switch on the headlights. If they dim after a few seconds, this indicates that the battery is discharged - recharge (see Section 3) or renew the battery. If the headlights glow brightly, operate the ignition switch and observe the lights. If they dim, then this indicates that current is reaching the starter motor, therefore the fault must lie in the starter motor. If an inertia type starter is fitted, check it is not jammed by placing the car in gear (manual transmission only) and rocking it to and fro. Alternatively, turn the armature with a small spanner on the square end protruding from the commutator end bracket. If the lights continue to glow brightly (and no clicking sound can be heard from the starter motor solenoid), this indicates that there is a fault in the circuit or solenoid - see following paragraphs. If the starter motor turns slowly when operated, but the battery is in good condition, then this indicates that either the starter motor is faulty, or there is considerable resistance somewhere in the circuit.

3 If a fault in the circuit is suspected, disconnect the battery leads (including the earth connection to the body), the starter/solenoid wiring and the engine/transmission earth strap. Thoroughly clean the connections, and reconnect the leads and wiring, then use a voltmeter or test lamp to check that full battery voltage is available at the battery positive lead connection to the solenoid, and that the earth is sound.

4 If the battery and all connections are in good condition, check the circuit by disconnecting the wire from the solenoid blade terminal. Connect a voltmeter or test lamp between the wire end and a good earth (such as the battery negative terminal), and check that the wire is live when the ignition switch is turned to the "start" position. If it is, then the circuit is sound - if not the circuit wiring can be checked as described in Chapter 12.

**HAYNES**  
**HiNT** Smear petroleum jelly around the battery terminals to prevent corrosion - corroded connections are amongst the most frequent causes of electrical system faults.

5 The solenoid contacts can be checked by connecting a voltmeter or test lamp between the battery positive feed connection on the starter side of the solenoid, and earth. When the ignition switch is turned to the "start" position, there should be a reading or lighted bulb, as applicable. If there is no reading or lighted bulb, the solenoid is faulty and should be renewed.

6 If the circuit and solenoid are proved sound, the fault must lie in the starter motor. In this event, it may be possible to have the starter motor overhauled by a specialist, but check on the cost of spares before proceeding, as it may prove more economical to obtain a new or exchange motor.

## 13 Starter motor - removal and refitting

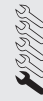

### Removal

- Disconnect the battery negative lead.
- If an ignition shield is fitted to the front of the engine, release the three retaining lugs and lift off the shield.
- For improved access if necessary, release the horn and horn bracket, and move them to one side.



13.4a Unscrew the nut securing the starter motor cable

4 On inertia type starters, undo and remove the nut and spring washer and then detach the starter motor cable from the terminal stud (see illustration). On pre-engaged type starters, undo the nut, and disconnect the leads at the upper terminal on the solenoid. Disconnect the leads at the two solenoid spade terminals, after identifying their positions (see illustration).

5 If the ignition coil is mounted on a bracket secured to the cylinder head, undo and remove the nut securing the bracket to the head and place the coil to one side.

6 Undo and remove the two bolts securing the starter motor to the flywheel housing, then lift the motor upwards and out of the engine compartment.

### Refitting

7 Refitting is the reverse sequence to removal.

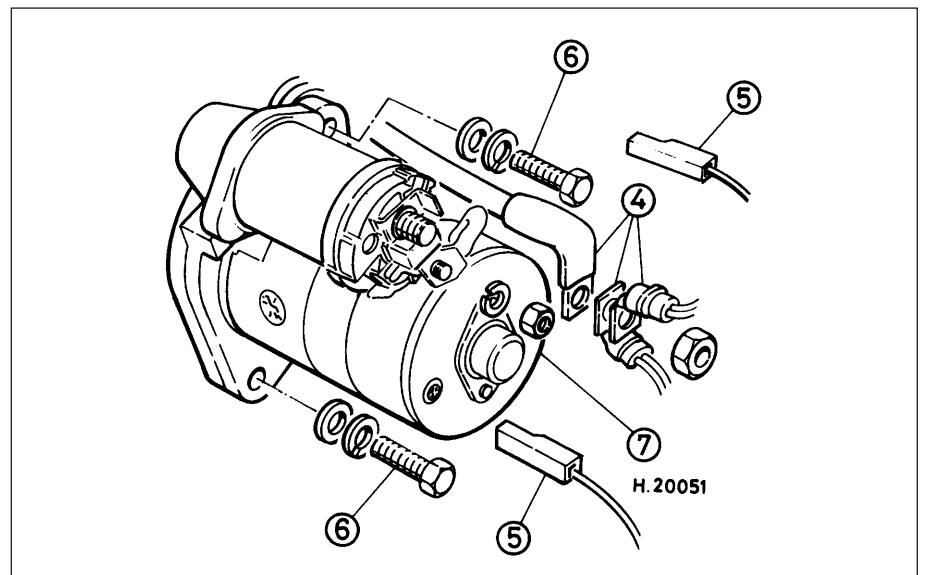

13.4b Pre-engaged starter motor attachments

- |                                 |                   |
|---------------------------------|-------------------|
| 4 Solenoid upper terminal leads | 6 Retaining bolts |
| 5 Solenoid spade terminal leads | 7 Starter motor   |

**14 Starter motor - testing and overhaul**



If the starter motor is thought to be suspect, it should be removed from the vehicle and taken to an auto-electrician for testing. Most auto-electricians will be able to supply and fit brushes at a reasonable cost. However, check on the cost of repairs before proceeding as it may prove more economical to obtain a new or exchange motor.

Renewal of the solenoid and, on the inertia type starter motor the drive pinion assembly, is described in the following Sections.

**15 Drive pinion assembly (inertia type starter) - removal and refitting**



**Removal**

- 1 With the starter motor removed from the car (Section 13) use a starter motor pinion compressor tool (available from automobile accessory stores), to compress the mainspring until sufficient clearance exists to enable the circlip on the end of the shaft to be removed. Remove the pinion compressor and then slide off the locating washer and mainspring.
- 2 Slide the remaining parts off the armature shaft with a rotary action.
- 3 Examine the teeth of the drive pinion that engage with the flywheel ring gear. If they are

badly worn on their leading edge, renew the pinion assembly. Bear in mind that if the drive pinion teeth are worn, the teeth on the flywheel ring gear are likely to be in a similar condition.

- 4 Inspect the remainder of the drive pinion components and renew the assembly if any are worn.

**Refitting**

- 5 Refitting the drive pinion is the reverse sequence to removal. **Note:** It is most important that the drive pinion components are completely free from oil, grease and dirt before reassembly. Under no circumstances should any of the parts be lubricated, as this will attract dust from the clutch which could cause the drive pinion to stick.

**16 Starter solenoid - removal and refitting**



**Removal**

**Remotely mounted solenoid (inertia type starter)**

- 1 Disconnect the battery negative lead.
- 2 Carefully ease back the rubber covers to gain access to the terminals (see illustration).
- 3 Make a note of the Lucar terminal connectors and detach these terminals.
- 4 Undo and remove the heavy duty cable terminal connection nuts and spring washers. Detach the two terminal connectors.



**16.2 Electrical connections at the starter solenoid**

- 5 Undo and remove the two securing screws and lift away the solenoid.

**Integral solenoid (pre-engaged type starter)**

- 6 Remove the starter motor as described in Section 13.
- 7 Undo the nut and disconnect the lead at the lower terminal on the solenoid.
- 8 Undo the two bolts and remove the solenoid yoke (see illustration).
- 9 Withdraw the plunger spring, unhook the plunger from the starter operating lever and remove the plunger.

**Refitting**

- 10 In all cases, refitting is the reverse sequence to removal.

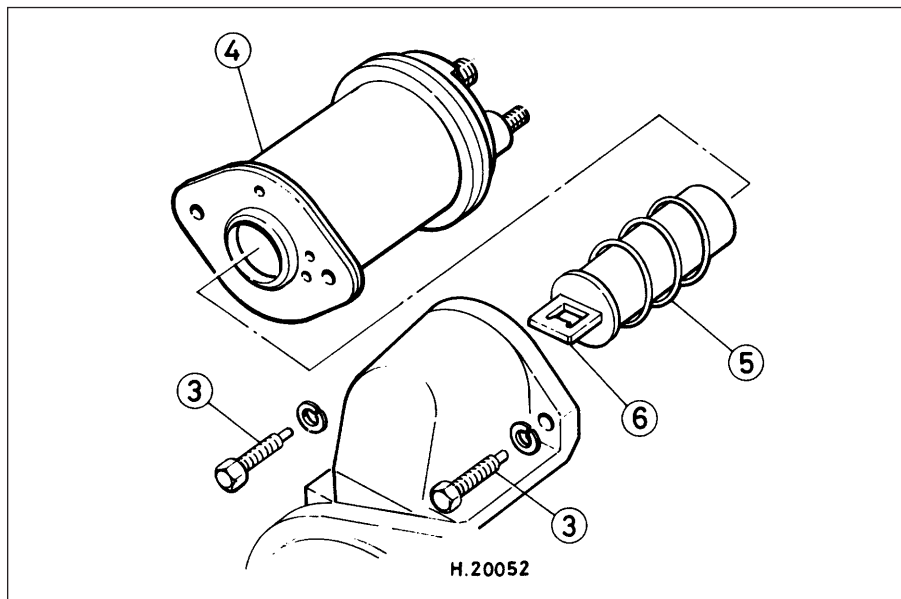

**16.8 Pre-engaged starter solenoid removal**





- 3 Retaining bolts      4 Solenoid yoke      5 Plunger spring      6 Plunger

# Chapter 5 Part B: Ignition system

## Contents

Ballasted ignition system (carburettor models) - identification . . . . .	2	Ignition coil - removal, testing and refitting . . . . .	10
Condenser - testing, removal and refitting . . . . .	7	Ignition system check . . . . .	See Chapter 1
Contact breaker points - adjustment . . . . .	5	Ignition system (carburettor models) - testing . . . . .	3
Contact breaker points - renewal . . . . .	6	Ignition system (fuel injection models) - testing . . . . .	4
Crankshaft sensor (fuel injection models) - removal and refitting . . . . .	11	Ignition timing - checking and adjustment . . . . .	13
Distributor - dismantling, inspection and reassembly . . . . .	9	Reluctor ring (fuel injection models) - removal and refitting . . . . .	12
Distributor lubrication . . . . .	See Chapter 1	Spark plug renewal . . . . .	See Chapter 1
Distributor - removal and refitting . . . . .	8	Transmission-controlled ignition advance system (carburettor models) - checking and component renewal . . . . .	14
General information . . . . .	1		

## Degrees of difficulty

<b>Easy</b> , suitable for novice with little experience 	<b>Fairly easy</b> , suitable for beginner with some experience 	<b>Fairly difficult</b> , suitable for competent DIY mechanic 	<b>Difficult</b> , suitable for experienced DIY mechanic 	<b>Very difficult</b> , suitable for expert DIY or professional 
---	--	--	---	--

## Specifications

### Carburettor models

#### System type

All except 1990 on, 1275 cc models . . . . .	Conventional contact breaker ignition
1990 on, 1275 cc models . . . . .	Lucas electronic ignition

#### Distributor - contact breaker ignition

##### Type:

All models except Cooper S Mk III:

Early type . . . . .	Lucas 25D4
Later type . . . . .	Lucas 45D4, 59D4 or Ducellier
Cooper S Mk III . . . . .	Lucas 23D4
Direction of rotor arm rotation . . . . .	Anti-clockwise
Contact breaker points gap . . . . .	0.35 to 0.40 mm
Dwell angle:	
Lucas 23D4 and 25D4 . . . . .	60° ± 3°
Lucas 45D4:	
Non-sliding contacts . . . . .	51° ± 5°
Sliding contacts . . . . .	57° ± 5°
Lucas 59D4 . . . . .	54° ± 5°
Ducellier . . . . .	57° ± 2°30'
Firing order . . . . .	1-3-4-2 (No 1 cylinder next to radiator)



## 5B•2 Ignition system

### Distributor - electronic ignition

Type .....	Lucas 65DM4 - Electronic
Ignition amplifier module .....	Lucas 9EM
Suppression capacitor .....	1 mf
Direction of rotor arm rotation .....	Anti-clockwise
Firing order .....	1-3-4-2 (No 1 cylinder next to radiator)

### Distributor serial numbers (Lucas)

(a) Mini 850 Saloon and Estate, 848 cc, 1969-72:	
Lucas 25D4 .....	41026
Lucas 45D4 .....	41411
(b) Mini 850 Van and Pick-up, 848 cc, 1969-72:	
Lucas 25D4 .....	41007
Lucas 45D4 .....	41410
(c) Mini 1000 Saloon and Estate, 998 cc, 1969-72:	
Lucas 25D4 .....	40931 or 41030
Lucas 45D4 .....	41412
(d) Mini 1000 Van and Pick-up, 998 cc, 1969-72:	
Lucas 25D4 .....	41007
Lucas 45D4 .....	41410
(e) Mini 1000 Automatic, and Mini Clubman Automatic, 998 cc, 1969-74:	
Lucas 25D4 .....	41134 or 41242
Lucas 45D4 .....	41417
(f) Mini Cooper S Mk III, 1275 cc, 1969-72:	
Lucas 23D4 .....	40819 or 41033
(g) Mini Clubman, 998 cc, 1969-72:	
Lucas 25D4 .....	41030
Lucas 45D4 .....	41412
(h) Mini 1275 GT, 1275 cc, 1969-72:	
Lucas 25D4 .....	41257
Lucas 45D4 .....	41419
(i) Mini 850 Saloon and variants, 848 cc, 1972-74:	
Lucas 25D4 .....	41026 or 41569*
Lucas 45D4 .....	41411 or 41570*
(j) Mini 1000 and Mini Clubman, Saloon and variants, 998 cc, 1972-74:	
Lucas 25D4 .....	41254 or 41246*
Lucas 45D4 .....	41212 or 41418*
(k) Mini 1275 GT, 1275 cc, 1972-76:	
Lucas 25D4 .....	41257 or 41214
Lucas 45D4 .....	41419
(l) Mini 850 Saloon and variants, 848 cc, 1974-76:	
Lucas 45D4 .....	41570
(m) Mini 1000 and Mini Clubman, Saloon and variants, 998 cc, manual and automatic transmission, 1974-76:	
Lucas 45D4 .....	41418
(n) Mini Clubman 1100, 1098 cc, 1974-76:	
Lucas 25D4 .....	41246
Lucas 45D4 .....	41418
(o) Mini 850 Saloon and variants, 848 cc, 1976 on:	
Lucas 45D4 .....	41417 or 41767
(p) Mini 1000 and Mini Clubman, Saloon and variants, 998 cc, manual and automatic transmission, 1976-78:	
Lucas 45D4 .....	41418 or 41793
(q) Mini Clubman 1100, 1098 cc, 1976 on:	
Lucas 45D4 .....	41418 or 41793
(r) Mini 1275 GT, 1275 cc, 1976-77:	
Lucas 45D4 .....	41419 or 41768
(s) Mini 1000 and Mini Clubman, Saloon and variants, 998 cc, manual and automatic transmission, 1978 on:	
Lucas 45D4 .....	41406 or 41765
(t) Mini 1275 GT, 1275 cc, 1978 on:	
Lucas 45D4 .....	41419 or 41768
(u) Mini Saloon and variants, 998 cc, 1982 on:	
Lucas 59D4 .....	41882
(v) Mini Saloon and variants, 1275 cc, 1990 on (electronic ignition) . . .	N/A

\* Alternative distributor fitted to a limited number of 1974 models

### Timing mark locations

Marks on flywheel, pointer on housing (scale on timing cover, notch on pulley - later models)

**Ignition timing**

**Note:** the reference letter in the first column refers to the vehicle type as listed above. If a Ducellier distributor is fitted, the timing setting is the same as the equivalent Lucas distributor.

Vehicle type	Static	Stroboscopic (vacuum pipe disconnected)
(a) .....	TDC	3° BTDC at 600 rpm
(b) .....	7° BTDC	10° BTDC at 600 rpm
(c) .....	5° BTDC	8° BTDC at 600 rpm
(d) .....	7° BTDC	10° BTDC at 600 rpm
(e) .....	4° BTDC	6° BTDC at 600 rpm
(f) .....	2° BTDC	4° BTDC at 600 rpm
(g) .....	5° BTDC	8° BTDC at 600 rpm
(h) .....	8° BTDC	10° BTDC at 600 rpm
(i) .....	TDC	19° BTDC at 1000 rpm
	9° BTDC*	14° BTDC at 1000 rpm*
(j) .....	5° BTDC	11° BTDC at 1000 rpm
	10° BTDC*	13° BTDC at 1000 rpm*
(k) .....	8° BTDC	13° BTDC at 1000 rpm
(l) .....	6° BTDC	11° BTDC at 1000 rpm
(m) .....	4° BTDC	7° BTDC at 1000 rpm
(n) .....	9° BTDC	12° BTDC at 1000 rpm
(o) .....	-	7° BTDC at 1000 rpm
(p) .....	-	7° BTDC at 1000 rpm
(q) .....	-	12° BTDC at 1000 rpm
(r) .....	-	13° BTDC at 1000 rpm
(s) .....	-	8° BTDC at 1000 rpm
(t) .....	-	13° BTDC at 1000 rpm
(u) 1983 to 1987 .....	-	8° + 0° -2° BTDC at 1500 rpm
1988 (category C) .....	-	10° + 0° -2° BTDC at 1500 rpm
1989-on low-compression .....	-	8° + 0° -2° BTDC at 1500 rpm
1989-on high-compression .....	-	10° + 0° -2° BTDC at 1500 rpm
(v) .....	-	5° + 1° BTDC at 1500 rpm

\*Alternative distributor

**Ignition coil**

Type:

848 cc and 1098 cc engines .....	Lucas LA12
998 cc engines:	
Pre-1982 models .....	Lucas LA12
1982 models .....	AC Delco 9977230 or Ducellier 520035A
1983 models on .....	GCL 144
1275 cc engines:	
Pre-1990 models except Cooper S Mk III and later 1275 GT .....	Lucas LA12
Cooper S Mk III .....	Lucas HA12
1275 GT, 1978 on .....	Lucas 15C6
1990 models on .....	GCL 143
Primary resistance at 20°C:	
Lucas LA12 and 15C6 .....	3.2 to 3.4 ohms
Lucas HA12 .....	3.0 to 3.4 ohms
AC Delco 9977230 or Ducellier 520035A .....	1.2 to 1.5 ohms
GCL 144 .....	1.3 to 1.5 ohms
GCL 143 .....	0.70 to 0.86 ohms
Ballast resistance:	
AC Delco 9977230 or Ducellier 520035A .....	1.3 to 1.5 ohms
GCL 144 .....	1.5 ohms

**Spark plugs** .....

See Chapter 1 *Specifications*

**Torque wrench settings**

	Nm	lbf ft
Distributor clamp .....	6.8	5

**Fuel injection models**

<b>System type</b> .....	Rover/Motronic Modular engine management system (MEMS), fully electronic, controlled by ECU
--------------------------	---

**Electronic control unit**

Type:

Cooper models .....	MNE 10027
All other manual transmission models .....	MNE 10025
All other automatic transmission models .....	MNE 10026

## 5B•4 Ignition system

### Crankshaft sensor

Type ..... ADU 7340

### Distributor

Type ..... NJC 10034  
Direction of rotor arm rotation ..... Anti-clockwise  
Firing order ..... 1-3-4-2 (No 1 cylinder next to radiator)  
Timing mark locations ..... Scale on timing cover, notch on pulley

### Ignition timing

Nominal value ..... 15° BTDC at idle\*

\*This value will constantly vary under control of the ECU idle function (by as much as -11° to +10°) - see text for further information.

### Ignition coil

Type ..... AUU 1326 or ADU 8779  
Primary resistance at 20°C ..... 0.71 to 0.81 ohms

Spark plugs ..... See Chapter 1 *Specifications*

### Torque wrench settings

	Nm	lbf ft
Crankshaft sensor bolts .....	6	4
Distributor clamp .....	6.8	5

## 1 General information

### Contact breaker point ignition system - carburettor models

In order that the engine can run correctly, it is necessary for an electrical spark to ignite the fuel/air mixture in the combustion chamber at exactly the right moment in relation to engine speed and load. The ignition system is based on feeding low tension voltage from the battery to the coil, where it is converted to high tension voltage. The high tension voltage is powerful enough to jump the spark plug gap in the cylinders many times a second under high compression pressures, providing that the system is in good condition and that all adjustments are correct.

The ignition system is divided into two circuits: the low tension circuit and the high tension circuit.

The low tension (sometimes known as the primary) circuit consists of the battery, lead to the starter solenoid, lead to the ignition switch, lead from the ignition switch to the low tension or primary coil windings (coil terminal +), and the lead from the low tension coil windings (coil terminal -) to the contact breaker points and condenser in the distributor.

The high tension circuit consists of the high tension or secondary coil windings, the ignition king lead from the centre of the coil to the centre of the distributor cap, the rotor arm, the spark plug HT leads and the spark plugs.

The system functions in the following manner. Low tension voltage is changed in the coil into high tension voltage by the opening and closing of the contact breaker points in the low tension circuit. High tension voltage is

then fed, via the carbon brush in the centre of the distributor cap, to the rotor arm of the distributor. The rotor arm revolves inside the distributor cap, and each time it comes in line with one of the four metal segments in the cap, which are connected to the spark plug leads, the opening and closing of the contact breaker points causes the high tension voltage to build up and jump the gap from the rotor arm to the appropriate metal segment. The voltage then passes, via the spark plug lead, to the spark plug, where it finally jumps the spark plug gap, before going to earth.

A ballasted ignition system is used on certain models to improve ignition performance, particularly when starting the engine. Ballast is provided by a low resistance lead incorporated in the supply from the ignition switch to the ignition coil + terminal. The starter solenoid circuit is wired so that upon operation of the starter, the ballast resistance is bypassed. This has the effect of slightly increasing coil primary voltage, which in turn temporarily increases HT output to improve starting.

The ignition is advanced and retarded automatically, to ensure that the spark occurs at just the right instant for the particular load at the prevailing engine speed. The ignition advance is controlled both mechanically and by a vacuum operated system on all but Cooper S models. Automatic advance is mechanical only on Cooper S models. The mechanical governor mechanism comprises two lead weights, which move out from the distributor shaft, due to centrifugal force, as the engine speed rises. As they move outwards they rotate the cam relative to the distributor shaft, and so advance the spark. The weights are held in position by two light springs, and it is the tension of the springs which is largely responsible for correct spark advancement. The vacuum control consists of

a diaphragm, one side of which is connected, via a small bore tube, to the carburettor, and the other side to the contact breaker plate. Depression in the inlet manifold and carburettor, which varies with engine speed and throttle opening, causes the diaphragm to move, so moving the contact breaker plate, and advancing or retarding the spark.

Certain models are also fitted with a transmission-controlled ignition advance system. The system consists of a vacuum line connected to the distributor-to-inlet manifold vacuum hose, which runs to an inhibitor switch located behind the gearchange remote control housing. A solenoid valve, operated by the inhibitor switch, is mounted in this vacuum line. When fourth gear is selected, the inhibitor switch energises the solenoid valve, and increased vacuum is applied to the advance mechanism of the distributor. When anything other than fourth gear is selected, the system is de-energised; vacuum is vented to atmosphere, the vacuum line to the distributor is sealed, and the system reverts to normal operation.

### Electronic ignition system - carburettor models

The Lucas electronic ignition system used on later 1275 cc engines consists of a distributor, an amplifier module and a coil. Externally, the distributor resembles a conventional type, but internally, a reluctor and a pick-up unit take the place of the cam and contact breaker points.

Each time one of the reluctor arms passes through the magnetic field of the pick-up coil, an electrical signal is sent to the amplifier module, which then triggers the coil in the same way as the opening of the points in a conventional system. Both centrifugal and vacuum advances are used in the accustomed manner.

Because there are no contact breaker points to wear out, the electronic ignition system is extremely reliable. As long as the distributor is lubricated, the spark plugs inspected or renewed at the specified maintenance intervals, and the leads and connections kept clean and dry, it is very unlikely that trouble will be experienced.

### **Electronic ignition system - fuel injection models**

The ignition system used on fuel injection models is fully electronic in operation, incorporating the Electronic Control Unit (ECU) (situated on the right-hand side of the engine compartment), a distributor (driven off the camshaft via a skew gear), a crankshaft sensor (mounted on the flywheel/torque converter housing, to register with the reluctor ring fixed to the rear of the flywheel/torque converter), as well as the spark plugs, HT leads, ignition coil, and associated wiring. The system is divided into two circuits; primary (low tension/LT) and secondary (high tension/HT). The primary circuit consists of the battery, ignition switch, ignition coil primary windings, ECU and wiring. The secondary circuit consists of the ignition coil secondary windings, the distributor cap and rotor arm, the spark plugs, and the HT leads connecting these.

The ECU controls both the ignition system and the fuel injection system, integrating the two in a complete engine management package; refer to Chapter 4B for information relating to the fuel injection side of the system.

As far as the ignition system is concerned, the ECU receives information in the form of electrical impulses or signals from the crankshaft sensor, from the coolant temperature sensor (which supplies it with engine temperature), from the throttle pedal switch (which tells it when the throttle is closed) and from the manifold absolute pressure sensor (which gives it the load on the engine). The crankshaft sensor works in conjunction with the reluctor ring, which is bolted onto the back of the flywheel. The reluctor ring has thirty-four poles on it, spaced 10° apart, with two missing poles 180° apart; the missing poles identify the cylinder TDC positions. The sensor reads these poles, to provide an accurate assessment of the engine speed and crankshaft position to the ECU.

All the above signals are compared by the ECU, with set values pre-programmed (mapped) into its memory; based on this information, the ECU selects the ignition timing appropriate to those values, and controls the ignition coil accordingly.

Note that this means that the distributor is just that, a distributor of the HT pulse to the appropriate spark plug; it has no effect whatsoever on the ignition timing. Also, the system is so sensitive that, at idle speed, the ignition timing may be constantly changing; this should be remembered if trying to check the ignition timing.

## **2 Ballasted ignition system (carburettor models) - identification**

**1** As mentioned in Section 1, certain models may be fitted with a ballasted ignition system to improve ignition performance when starting.

**2** To determine if a vehicle is equipped with a ballasted ignition system, check for the presence of a supplementary wiring harness, incorporating the white/pink ballast resistor lead, between the fuse block and the ignition coil LT terminal.

**3** The ballast resistor lead replaces the original coil feed. The original lead is colour-coded white, and is retained in the harness to accommodate vehicles not fitted with a ballasted system. Do not connect this white lead to the ignition coil; it must remain taped to the harness.

**4** Failure to observe this warning will result in coil overheating and premature contact breaker point failure. Similar damage will occur if a coil designed for use with a ballasted system is fitted to a non-ballasted system, this being due to the excessive primary current produced. Should it ever be necessary to renew the coil, ensure that the replacement is of the correct type.

## **3 Ignition system (carburettor models) - testing**



### **Contact breaker ignition system**

**1** By far the majority of breakdown and running troubles are caused by faults in the ignition system, either in the low tension or high tension circuit. There are two main symptoms indicating ignition faults. Either the engine will not start or fire, or the engine is difficult to start and misfires. If it is a regular misfire, ie the engine is only running on two or three cylinders, the fault is likely to be in the secondary or high tension circuit. If the misfiring is intermittent, the fault could be in either the high or low tension circuits. If the engine stops suddenly or will not start at all, it is likely that the fault is in the low tension circuit. Loss of power and overheating, apart from carburettor settings, are normally due to faults in the distributor or incorrect ignition timing.

#### **Engine fails to start**

**2** If the engine fails to start and the car was running normally when it was last used, first check there is fuel in the fuel tank. If the engine turns over normally on the starter motor and the battery is evidently well charged, then the fault may be in either the high or low tension circuits. First check the HT circuit. If the battery is known to be fully charged, the ignition light comes on and the starter fails to turn the engine, check the tightness of the

leads on the battery terminals and the security of the earth lead at its connection on the body (don't forget to check the engine to body earth strap as well). It is quite common for the leads to have worked loose, even if they look and feel secure. If one of the battery terminal posts gets very hot when trying to work the starter motor, this is a sure indication of a faulty connection to that terminal.

**3** One of the most common reasons for bad starting is wet or damp spark plug HT leads and distributor. Remove the distributor cap. If condensation is visible internally, dry the cap with a rag and wipe over the HT leads. Refit the cap and spray the cap, leads and spark plugs with a water dispersant aerosol.

**4** If the engine still fails to start, check that HT voltage is reaching the spark plugs by disconnecting each plug lead in turn at the spark plug end and holding the end of the cable about 5 mm away from the cylinder block. If the plug caps are not detachable, insert a nail or piece of stiff wire into the cap. Hold the lead with insulating material - eg a rubber glove, a dry cloth, or insulated pliers. With the ignition switched on, have an assistant crank the engine on the starter motor: a strong blue spark should be seen and heard to jump from the end of the lead to the block. If it does, this suggests that HT voltage is reaching the plugs, and that either the plugs themselves are defective, the ignition timing is grossly maladjusted, or the fault is not in the ignition system. If the spark is weak or absent, although the cranking speed is good, proceed with the checks below.

**5** Remove the HT lead which enters the centre of the distributor cap. Hold the end near the block and repeat the check above. A good spark now, if there was none at the plug lead, indicates that HT voltage is not being transmitted to the plug leads. Check the rotor arm, distributor cap and HT leads thoroughly as described in Chapter 1. If there is no spark at the HT lead from the coil, check the connections at the coil end of the lead. If it is in order start checking the low tension circuit as follows.

**6** Separate the contact breaker points with a piece of paper between their contact faces then switch on the ignition. Using a 12 volt voltmeter or a 12 volt bulb and two lengths of wire, test between the low tension wire to the coil (marked SW or +) and earth. No reading indicates a break in the supply from the ignition switch. Check the wiring and the connections at the switch and correct any problems found. A reading on the voltmeter or illumination of the test bulb indicates that voltage is reaching the coil and the problem is therefore a faulty coil, faulty condenser or a broken lead between the coil and distributor.

**7** Remove the condenser from the baseplate on Lucas distributors or disconnect the condenser lead on the Ducellier version. With the contact breaker points open, test between the moving point and earth. If there is now a reading then the fault is in the condenser. Fit a new condenser and the engine should start.



## 5B•6 Ignition system

**8** With no reading from the moving point and earth, test between the coil negative terminal (marked CB or -) and earth. A reading here indicates a broken wire between the coil and distributor which must be repaired. No reading confirms that the coil has failed and must be renewed. If the coil is to be renewed, ensure that the correct type is obtained. The coils used on ballasted and non-ballasted systems are not interchangeable (see Section 2 for further details).

**9** Where a ballasted ignition system is fitted, if the engine starts when the starter is operated, but stops as soon as the ignition key is returned to the normal running position, the resistive wire may be open circuit. Connect a temporary lead between the coil positive (SW or +) terminal and the battery positive terminal. If the engine now runs correctly, renew the resistive wire. **Note:** *Bypassing the resistive wire in this way must only be done briefly for the purpose of this test. The wire must not be permanently bypassed, otherwise the coil will overheat and be irreparably damaged.*

### Engine misfires

**10** Uneven running and misfiring should first be checked by seeing that all leads, particularly HT, are dry and connected properly. Ensure that they are not shorting to earth through broken or cracked insulation. If they are you should be able to see and hear it. If not, then check the plugs, contact breaker points and condenser just as you would in a case of total failure to start. A regular misfire can be isolated by removing each HT lead from its spark plug in turn, (taking precautions against electric shock) while the engine is idling. Removing a good lead will accentuate the misfire, whilst removing the defective lead will make no difference.

**11** Once the defective cylinder is located, switch off the engine, remove the lead from the spark plug again and hold the end about 5 mm away from the cylinder block. If the plug caps are not detachable, insert a nail or piece of stiff wire into the cap. Restart the engine. If the sparking is fairly strong and regular, the fault must lie in the spark plug. Remove and examine its condition as described in Chapter 1. If the spark plug is proved to be satisfactory, there may be an internal engine problem such as loss of compression on the defective cylinder. Carry out a compression test, as described in Chapter 2A to determine the condition of the engine internally.

**12** If there is no spark at the end of the HT lead, or if it is weak and intermittent, check the entire length of the lead from the distributor cap to the spark plug. If the insulation is cracked or perished, renew the lead. Check the connections at the distributor cap at the same time.

**13** If there is still no spark, carefully examine the condition of the distributor cap as described in Chapter 1, looking closely for signs of cracks or tracking between the internal segments.

**14** Apart from the ignition timing being incorrect, other causes of misfiring have already been dealt with under the sub-Section dealing with the failure of the engine to start. To recap, these are:

- The coil may be faulty giving an intermittent misfire.
- There may be a damaged wire or loose connection in the low tension circuit.
- The condenser may be short-circuited.
- There may be a mechanical fault in the distributor (incorrectly assembled contact breaker points or broken contact breaker spring).

**15** If the ignition timing is too far retarded it should be noted that the engine will tend to overheat and there will be a quite noticeable drop in power. If the engine is overheating and the power is down, and if the ignition timing is correct, then the carburettor should be checked as it is likely that this is where the fault lies.

### Electronic ignition system

**Note:** *Refer to the warning given in Section 1 of Part A of this Chapter before starting work. Always switch off the ignition before disconnecting or connecting any component and when using a multi-meter to check resistances.*



**Warning:** *Voltages produced by an electronic ignition system are considerably higher than those produced by conventional ignition systems. Extreme care must be taken when working on the system with the ignition switched on. Persons with surgically-implanted cardiac pacemaker devices should keep well clear of the ignition circuits, components and test equipment.*

### General

**16** Electronic ignition is normally very reliable; if it does fail, such failure tends to be complete. If a fault does occur, or if performance is suspect, the following test procedure should be used to isolate the problem area.

**17** An electrical multi-meter which can measure voltage and resistance (ohms) will be required for testing purposes.

### Electronic ignition system test procedure

#### Refer to the accompanying table

**18** If, after carrying out the test procedures the ignition amplifier module is diagnosed as being faulty, make sure that the wiring is intact and secure.

Test	Remedy
<b>1</b> Is the battery voltage greater than 11.7 volts?	Yes: Proceed to Test 2 No: Recharge the battery
<b>2</b> Is the voltage at the coil "+" terminal within 1 volt of battery voltage?	Yes: Proceed to Test 3 No: Faulty wiring or connector between ignition switch and coil, or faulty ignition switch
<b>3</b> Is the resistance between the ignition coil "+" and "-" terminals between 0.4 and 0.9 ohms?	Yes: Proceed to Test 4 No: Renew the ignition coil
<b>4</b> Is the resistance between the ignition coil "+" and HT terminals between 5.0 and 15.0 kohms?	Yes: Proceed to Test 5 No: Renew the ignition coil
<b>5</b> Connect a low-wattage bulb across the ignition coil "+" and "-" terminals, and spin the engine on the starter. Does the bulb flash?	Yes: Proceed to Test 6 No: Proceed to Test 10
<b>6</b> Is the resistance of any HT lead greater than 20 kohms?	Yes: Renew the HT lead No: Proceed to Test 7
<b>7</b> Are there any signs of tracking on the ignition coil, distributor cap or rotor arm?	Yes: Renew the component as necessary No: Proceed to Test 8
<b>8</b> Is the ignition timing correct?	Yes: Proceed to Test 9 No: Adjust ignition timing
<b>9</b> Are the spark plugs in good condition?	Yes: Check carburettor settings and engine mechanical condition No: Renew the spark plugs
<b>10</b> Are the ignition amplifier module connections sound?	Yes: Proceed to Test 11 No: See paragraphs 18 to 21 of this Section
<b>Section</b>	
<b>11</b> With the module removed, is the resistance of the distributor pick-up coil between 950 and 1150 ohms?	Yes: See paragraphs 18 to 21 of this Section No: Renew the distributor pick-up coil

**19** As a double-check, remove the module, gasket and connector, and lightly squeeze together the terminals inside the connector. Clean the terminals in the module and distributor before refitting the module, and remember to apply heat-conducting silicone grease to the mounting face on the distributor.  
**20** Disconnect the wiring from the module, clean the terminals, and lightly squeeze together the terminals inside the connector before refitting it. Make sure that the connector is fully located over the base.  
**21** Check that the LT leads are correctly fitted to the ignition coil.

#### 4 Ignition system (fuel injection models) - testing



**1** If a fault appears in the engine management (fuel injection/ignition) system first ensure that the fault is not due to a poor electrical connection or poor maintenance; ie, check that the air cleaner filter element is clean, the spark plugs are in good condition and correctly gapped, that the engine breather hoses are clear and undamaged, referring to Chapter 1 for further information. Also check that the accelerator cable is correctly adjusted as described in Chapter 4B. If the engine is running very roughly, check the valve clearances and compression pressures as described in Chapter 1 and 2A.  
**2** The only ignition system checks which can be carried out by the home mechanic are those described in Chapter 1, relating to the spark plugs, HT leads, rotor arm and distributor cap, and the ignition coil test described in Section 10 of this Chapter.  
**3** If these checks fail to reveal the cause of the problem the vehicle should be taken to a suitably equipped Rover dealer for testing. A wiring block connector is incorporated in the engine management circuit into which a special electronic diagnostic tester can be plugged. The tester will locate the fault quickly and simply alleviating the need to test all the system components individually which is a time consuming operation that carries a high risk of damaging the ECU.



5.1 Removing the distributor cap

#### 5 Contact breaker points - adjustment



**1** If an ignition shield is fitted over the front of the engine, release the three plastic retaining lugs and lift away the shield. Detach the two spring clips or undo the two screws securing the distributor cap to the distributor body and lift off the cap (see illustration).  
**2** On models that have a distributor shield attached to the inner front panel, remove the ignition coil HT lead from the centre of the distributor cap. Now detach the two distributor cap securing spring clips or screws. With careful manipulation it should be possible to withdraw the distributor cap upwards through the small space between the rotor arm and the distributor shield. If difficulty is experienced, undo and remove the retaining screws and lift out the shield.  
**3** With the distributor cap removed, clean and inspect it thoroughly as described in Chapter 1.  
**4** Gently prise the contact breaker points open to examine the condition of their faces. If they are rough and pitted or dirty, they should be renewed. Disregard any blue discoloration which may be apparent on their faces. This is due to the formation of tungsten oxide; it has no detrimental effect on ignition performance nor is it indicative of condenser failure.  
**5** Assuming that the points are in a satisfactory condition, or that they have been renewed, the gap between the two faces should be measured using feeler blades. Note however that on later models no contact breaker points gap is quoted by the manufacturers. On these models, the gap can only be adjusted using the dwell angle method described from paragraph 10 onward.

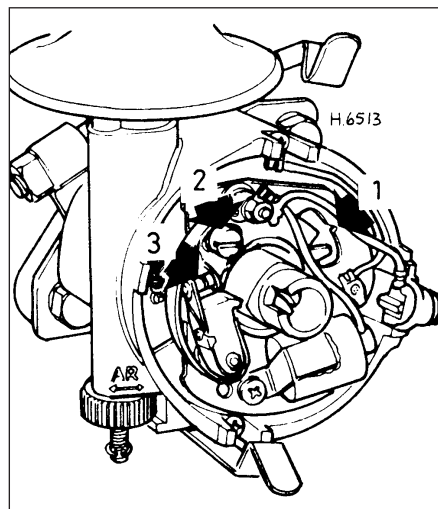

5.6a Contact breaker points adjustment - Lucas 25D4 distributor

- 1 Screwdriver slot for adjustment
- 2 Contact plate securing screw
- 3 Contact breaker points

**6** To adjust the gap using feeler blades, turn the engine over until the heel of the contact breaker arm is on the peak of one of the four cam lobes. On manual transmission models, the engine can be turned over quite easily by engaging top gear and moving the car backwards or forwards until the points are fully open. This should only be done on level ground; and make sure that the car cannot run away! An alternative method, and the method that should be used on automatic transmission models, is to press the fan belt midway between the water pump pulley and dynamo or alternator pulley and then turn the fan blades. With the points fully open, a feeler blade equal to the contact breaker points gap, as stated in the *Specifications*, should now just fit between the contact faces (see illustrations).

**HAYNES HINT** Turning the engine will be easier if the spark plugs are removed first - see Chapter 1.

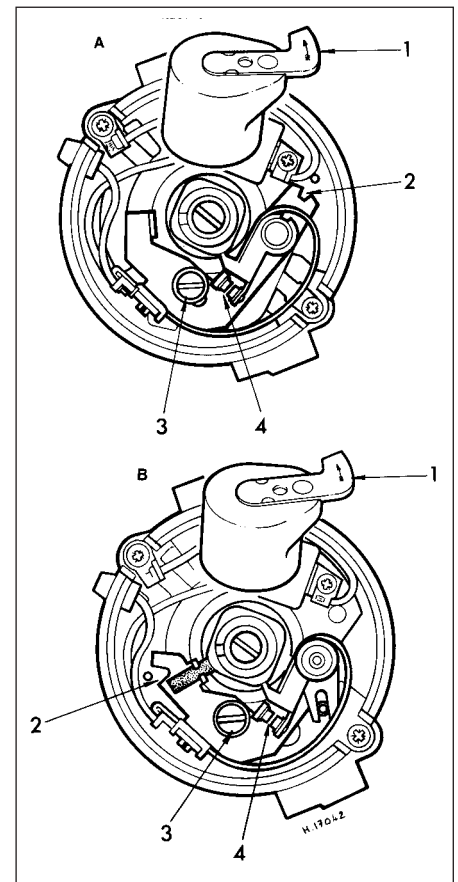

5.6b Contact breaker points adjustment - Lucas 45D4 and 59D4 distributor

- A Non-sliding contact type
- B Sliding contact type
- 1 Rotor arm
- 2 Screwdriver slot for adjustment
- 3 Contact plate securing screw
- 4 Contact breaker points

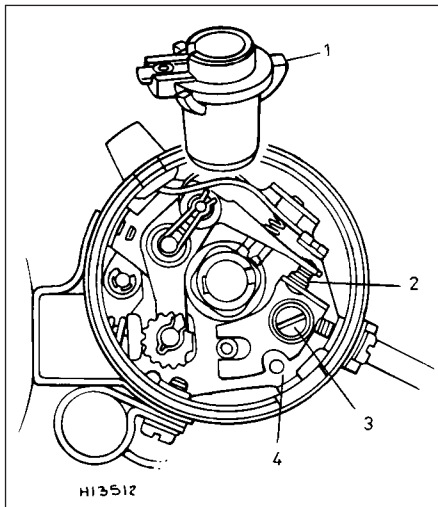

### 5.6c Contact breaker points adjustment - Duccellier distributor

- 1 Rotor arm
- 2 Contact breaker points
- 3 Contact plate securing screw
- 4 Screwdriver slot for adjustment

7 If the gap is too large or too small, slacken the contact breaker securing screw slightly using a short screwdriver. Now insert the screwdriver into the slot on the side or at the rear of the contact breaker plate and move the plate in the desired direction to increase or decrease the gap (see illustration).

8 Tighten the securing screw and recheck the gap.

9 With the points correctly adjusted, refit the distributor cap and ignition shield or distributor shield if previously removed.

10 If a dwell meter is available, a far more accurate method of setting the contact breaker points gap is by measuring and setting the distributor dwell angle.

11 The dwell angle is the number of degrees of distributor cam rotation during which the contact breaker points are closed, ie the period from when the points close after being

opened by one cam lobe until they are opened again by the next cam lobe. The advantages of setting the points by this method are that any wear of the distributor shaft or cam lobes is taken into account, and also the inaccuracies of using a feeler blade are eliminated. In general, a dwell meter should be used in accordance with the manufacturer's instructions. However, the use of one type of meter is outlined as follows.

12 To set the dwell angle, remove the distributor cap and rotor arm, and connect one lead of the dwell meter to the + terminal on the coil, and the other lead to the - coil terminal.

13 Whilst an assistant turns on the ignition and operates the starter, observe the reading on the dwell meter scale. With the engine turning over on the starter, the reading should be as stated in the *Specifications*. **Note:** *Fluctuation of the dwell meter needle indicates that the engine is not turning over fast enough to give a steady reading. If this is the case, remove the spark plugs and repeat the checks.*

14 If the dwell angle is too small, the contact breaker point gap is too wide, and if the dwell angle is excessive, the gap is too small.

15 Adjust the contact breaker points gap, while the engine is cranking using the method described in paragraph 7, until the correct dwell angle is obtained.

16 When the dwell angle is satisfactory, disconnect the meter and refit the rotor arm, distributor cap and ignition or distributor shield.

### 6 Contact breaker points - renewal



**Note:** *Carburettor models without electronic ignition may be fitted with either a Lucas 23D4, 25D4, 45D4, 59D4 or Duccellier distributor. Identify the unit being worked on by referring to the illustrations and then*

*proceed as described below according to distributor type.*

### Lucas 23D4 and 25D4

1 Remove the distributor cap as described in the previous Section then withdraw the rotor arm from the distributor spindle.

2 Undo and remove the small terminal nut, together with the washer under its head, if fitted. Lift off the flanged nylon insulator, the condenser lead, and the low tension lead from the terminal post.

3 Using a short screwdriver, unscrew the single screw securing the adjustable contact breaker plate to the distributor baseplate. Lift off the screw and flat washer, taking care not to drop them inside the distributor. The contact breaker points can now be withdrawn.

4 To refit the points, first position the adjustable contact breaker plate and secure it with the retaining screw and washer. Fit the fibre washer to the terminal post (and pivot post where applicable), and then place the contact breaker arm over it. Insert the flanged nylon insulator with the condenser lead immediately under its head, and the low tension lead under that, over the terminal post. Place the washer over the terminal post and finally the retaining nut.

5 If a one-piece contact breaker point assembly is being refitted, position the contact assembly on the distributor baseplate and refit the retaining screw and washer.

6 Place the condenser lead and low tension lead under the head of the upper nylon insulator, and then fit the insulator to the terminal post. Finally refit the washer and retaining nut.

7 The contact breaker points gap should now be adjusted as described in the previous Section.

### Lucas 45D4 and 59D4

8 Remove the distributor cap as described in the previous Section then withdraw the rotor arm from the distributor spindle (see illustration).



5.6d Using feeler blades to check the contact breaker points gap



5.7 Adjusting the contact breaker points



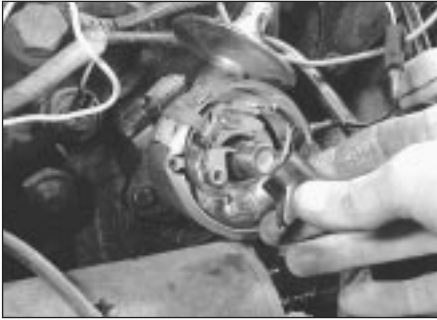

6.8 Lift off the rotor arm . . .

**9** Using a short screwdriver, unscrew the single screw securing the adjustable contact breaker plate to the distributor baseplate. Lift off the screw and washer, taking care not to drop them inside the distributor.

**10** Lift the contact assembly off the baseplate and detach the tensioning arm from the insulator. Release the terminal containing the condenser and low tension leads from the end of the arm and then lift away the contact breaker points (see illustrations).

**11** To refit the points first engage the terminal containing the condenser and low tension leads with the end of the tensioning arm. Make sure that the black lead is uppermost.

**12** Position the tensioning arm in the insulator, place the contact assembly on the baseplate and refit the retaining screw and washer.

**13** The contact breaker points gap should now be adjusted as described in the previous Section.

### Ducellier

**14** Remove the distributor cap as described in the previous Section then withdraw the rotor arm from the distributor spindle.

**15** Disconnect the contact breaker low tension lead at the connector.

**16** Using a small screwdriver or pointed-nose pliers, carefully extract the circlip securing the

moving contact arm to the pivot post. Remove the washer and lift off the moving contact arm and low tension lead assembly.

**17** Unscrew the single screw securing the adjustable contact breaker plate to the baseplate. Lift off the screw and washer taking care not to drop them inside the distributor. Now lift away the breaker plate.

**18** To refit the points first position the adjustable contact breaker plate on the baseplate and refit the retaining screw and washer.

**19** Place the moving contact arm over the pivot post and engage the tensioning arm with the insulator. Refit the washer and circlip to the pivot post.

**20** Enter the grommet of the low tension lead into the slot on the side of the distributor and reconnect the lead.

**21** The contact breaker points gap should now be adjusted as described in the previous Section.

## 7 Condenser - testing, removal and refitting



**Note:** Carburettor models without electronic ignition may be fitted with either a Lucas 23D4, 25D4, 45D4, 59D4 or Ducellier distributor. Identify the unit being worked on by referring to the illustrations accompanying Section 5, then proceed as described below according to distributor type.

### Testing

**1** The purpose of the condenser (sometimes known as a capacitor) is to prevent excessive arcing of the contact breaker points, and to ensure that a rapid collapse of the magnetic field, created in the coil, and necessary if a healthy spark is to be produced at the plugs, is allowed to occur.

**2** The condenser is fitted in parallel with the contact breaker points. If it becomes faulty it

will cause ignition failure, as the points will be prevented from cleanly interrupting the low tension circuit.

**3** If the engine becomes very difficult to start, or begins to miss after several miles of running, and the contact breaker points show signs of excessive burning, then the condition of the condenser must be suspect. When examining the contact breaker points, disregard any blue discoloration which may be apparent on their faces. This is due to the formation of tungsten oxide, and has no detrimental effect on ignition performance; it is not indicative of condenser failure. A further test can be made by separating the points by hand, with the ignition switched on. If this is accompanied by an excessively strong flash, it indicates that the condenser has failed.

**4** Without special test equipment, the only reliable way to diagnose condenser trouble is to renew the suspect unit and note if there is any improvement in performance.

**5** Removal and refitting of the condenser varies according to distributor type as follows.

### Removal

#### Lucas 23D4 and 25D4

**6** Remove the distributor cap and rotor arm, referring to Section 5 if necessary.

**7** Undo and remove the nut and washer (if fitted) from the contact breaker terminal post. Withdraw the flanged nylon insulator and release the condenser lead.

**8** Undo and remove the small screw securing the condenser to the distributor baseplate and lift the condenser away.

#### Lucas 45D4 and 59D4

**9** Remove the distributor cap and rotor arm, referring to Section 5 if necessary.

**10** Release the contact breaker points tensioning arm from the insulator and detach the condenser and low tension lead terminal from the end of the arm.

**11** Undo and remove the small screw securing the condenser to the distributor baseplate.

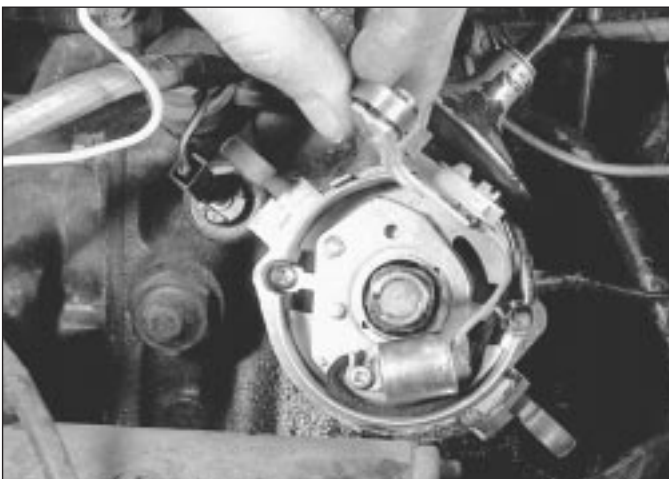

6.10a . . . and with the retaining screw removed, lift the contact assembly off the baseplate



6.10b The LT terminal can then be detached from the tensioning arm





**8.5 The timing marks on the flywheel can be viewed through the aperture in the housing using a mirror**

**12** Disconnect the distributor low tension lead at the connector, push the lead and grommet into the inside of the distributor body and lift away the condenser complete with low tension lead assembly.

#### Ducellier

**13** On the Ducellier distributor the condenser is mounted externally and removal consists of simply disconnecting the lead and undoing the retaining screw.

#### Refitting

**14** In all cases, refitting is the reverse sequence to removal. On the Lucas 45D4 and 59D4 distributors, ensure that when the terminal is connected to the tensioning arm, the black lead is uppermost.

### 8 Distributor - removal and refitting



#### Removal

**1** Release the three plastic retaining lugs and lift the ignition shield off the front of the engine. On models that have a distributor shield attached to the inner front panel, undo and remove the retaining screws and withdraw the shield.

**2** Spring back the two distributor cap retaining clips or undo the screws then place the distributor cap to one side.

**3** Gain access to the ignition timing marks by undoing the two bolts securing the inspection plate to the top of the flywheel housing and lifting off the plate. On models fitted with automatic transmission, withdraw the rubber grommet from the top of the converter housing. On later models there is a timing scale on the timing cover, together with a notch or pointer on the crankshaft pulley.

**4** Turn the engine over until No 1 piston is approaching TDC on the compression stroke. This can be checked by removing No 1 spark plug and feeling the pressure being developed in the cylinder as the piston rises, or by removing the rocker cover and noting when the valves of No 4 cylinder are rocking, ie the inlet valve just opening and the exhaust valve

just closing. On manual transmission models, the engine can be turned over quite easily by engaging top gear and moving the car forwards. This should only be done on level ground; and make sure that the car cannot run away! An alternative method, and the method that should be used on automatic transmission models, is to press the fan belt midway between the water pump pulley and dynamo or alternator pulley and then turn the fan blades.

**5** Continue turning the engine, in the correct direction of rotation, until No 1 piston is at TDC on the compression stroke. Verify this by checking that the timing marks are aligned. The timing marks on the flywheel (or torque converter), and the pointer on the housing, can be viewed through the inspection aperture using a small mirror (see illustration). The 1/4 mark on the flywheel or torque converter indicates TDC and should be aligned with the pointer in the housing. On later models with a timing scale on the timing cover, the notch in the crankshaft pulley should be aligned with the 0 pointer on the timing cover scale.

**6** The distributor rotor arm should now be pointing towards the No 1 spark plug HT lead segment in the distributor cap indicating that

the crankshaft is correctly positioned with number 1 cylinder at TDC on its compression stroke. Temporarily place the cap in position to verify this if necessary. If the rotor arm is pointing at the No 4 HT lead segment in the cap, rotate the crankshaft one full turn (360°) until the TDC timing marks are realigned and the rotor arm is pointing at the No 1 segment.

**7** On carburettor models, detach the distributor vacuum advance pipe from the vacuum unit (where applicable), then either disconnect the low tension (LT) lead at the connector or disconnect the ignition amplifier multiplug according to distributor type (see illustration).

**8** Using a dab of paint or a small file, make a mark between the distributor body and the clamping plate. This will ensure that the distributor is refitted in exactly the same position and that the timing is not lost.

**9** If the distributor is retained by a clamping plate having a pinch bolt and nut, slacken one of the bolts securing the clamping plate to the cylinder block and then slacken the pinch bolt. If a C-shaped plate is used to retain the distributor, undo and remove the securing bolt and lift away the plate.

**10** The distributor can now be withdrawn from the engine.

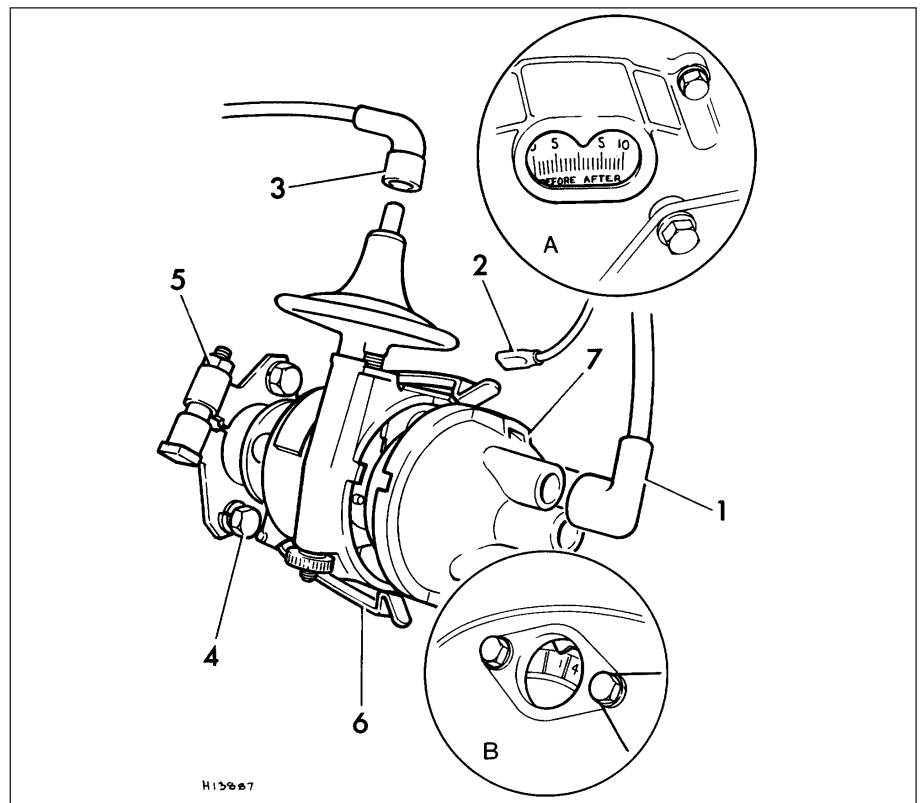

**8.7 Distributor removal**

1 HT lead  
2 LT lead terminal connector

Inset: Timing marks:

3 Vacuum pipe connection  
4 Clamp securing bolts and spring washers

A Automatic transmission

5 Clamp nut and bolt  
6 Spring clip  
7 Distributor cap

B Manual transmission

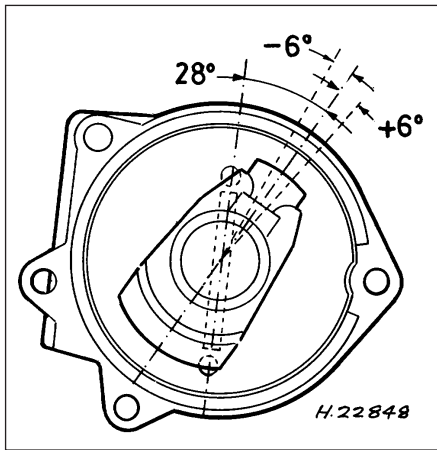

8.12 Correct distributor rotor arm offset and body position (No 1 cylinder at TDC on compression stroke) - fuel-injected models

### Refitting

**11** Ensure that the crankshaft is still positioned so that number 1 cylinder is at TDC on its compression stroke, then refit the distributor to the engine, aligning the drive dog with the slot in the drive. When inserting the distributor into the engine aperture, press down lightly on the distributor body and at the same time rotate the distributor shaft slightly. When the lug on the distributor drive dog engages with the slot on the driveshaft, the distributor will move in toward the engine a further 6.3 mm.

**12** If the original distributor is being refitted, align the marks made on removal between the distributor body and clamp plate. If a new distributor is being fitted to carburettor models, turn the distributor body until the rotor arm is pointing toward the No 1 HT lead segment in the distributor cap. If a new distributor is being fitted to fuel injection models, turn the distributor body until the rotor arm and body are aligned as shown (see illustration).

**13** With the distributor correctly positioned, tighten the pinch bolt and clamp plate bolt or refit the C-shaped plate and tighten the bolt.

**14** Refit the cap to the distributor, and secure with the clips or retaining screws.

**15** If removed, refit the rocker cover and reconnect any disturbed spark plug HT leads.

**16** On carburettor models, reconnect the distributor wiring and vacuum advance pipe.

**17** Before refitting the remainder of the components on carburettor models, the ignition timing must be checked and adjusted as described in Section 13.

### 9 Distributor - dismantling, inspection and reassembly



**Note:** The following procedures are applicable to the distributors fitted to carburettor models. The distributor fitted to fuel injection models consists simply of a shaft and housing and cannot be dismantled. Check the cost and availability of replacement parts before proceeding. If the distributor is excessively worn it may be beneficial (or necessary) to obtain a reconditioned unit.

### Dismantling

#### Lucas 23D4 and 25D4

**1** Remove the distributor from the car as described in Section 8.

**2** Withdraw the rotor arm from the distributor spindle and then remove the contact breaker points as described in Section 6.

**3** Undo and remove the single retaining screw and lift off the condenser (see illustration).

**4** Unhook the vacuum unit operating spring from the post on the distributor baseplate (not 23D4).

**5** Undo and remove the two small screws and spring washers which secure the baseplate to the distributor body. Note that one of these screws also retains the baseplate earth lead.

**6** Now carefully lift out the baseplate.

**7** Make a note of the position of the rotor arm drive slot, in the spindle, in relation to the offset driving dog at the opposite end of the distributor. It is essential that this is reassembled correctly, otherwise the ignition timing will be 180° out.

**8** Undo and remove the cam spindle retaining screw which is located in the centre of the rotor arm drive.

**9** Remove the two centrifugal advance weight tension springs and then lift off the cam spindle. It is quite likely that the cam spindle will prove difficult to remove and will not slide readily off the shaft. If this is the case, apply liberal amounts of penetrating oil to the top of the spindle and rotate it back and forth while at the same time pulling upward. This should free the spindle and allow it to be removed from the shaft.

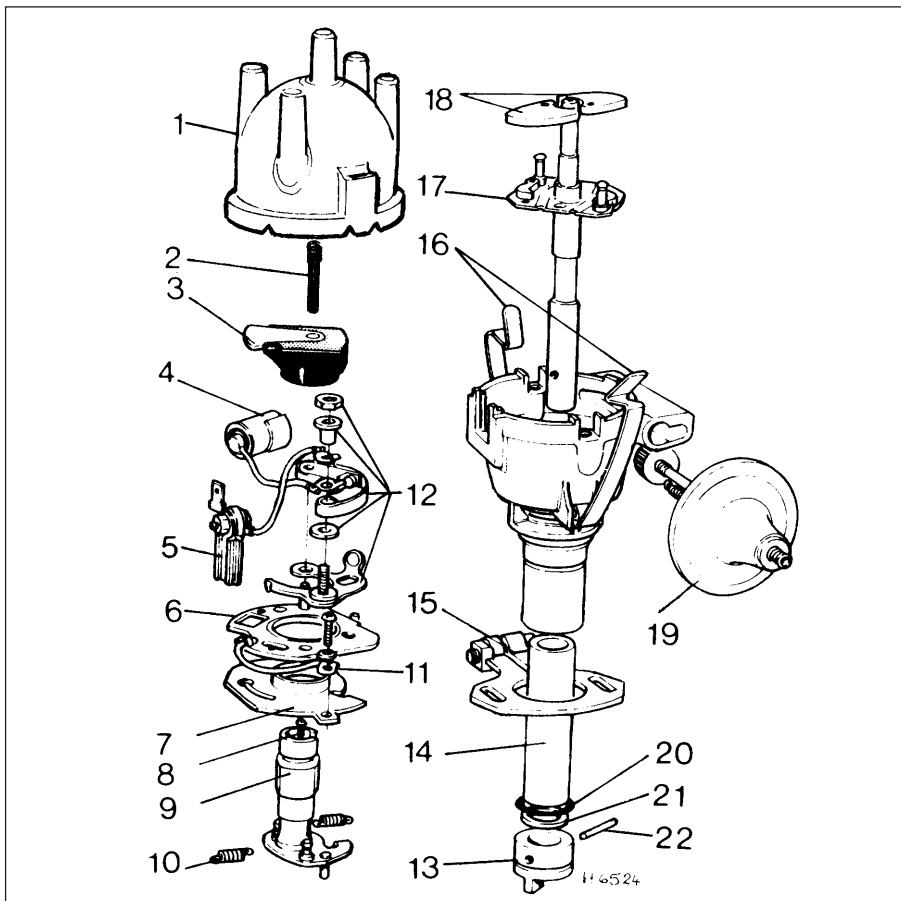

9.3 Exploded view of Lucas 25D4 distributor

- |                     |                           |                           |
|---------------------|---------------------------|---------------------------|
| 1 Distributor cap   | 8 Cam screw               | 16 Cap retaining clips    |
| 2 Brush and spring  | 9 Cam                     | 17 Shaft and action plate |
| 3 Rotor arm         | 10 Advance spring         | 18 Bob weights            |
| 4 Condenser         | 11 Earth lead             | 19 Vacuum unit            |
| 5 Terminal and lead | 12 Contact breaker points | 20 O-ring oil seal        |
| 6 Moving baseplate  | 13 Driving dog            | 21 Thrust washer          |
| 7 Fixed baseplate   | 14 Bush                   | 22 Taper pin              |
|                     | 15 Clamp plate            |                           |

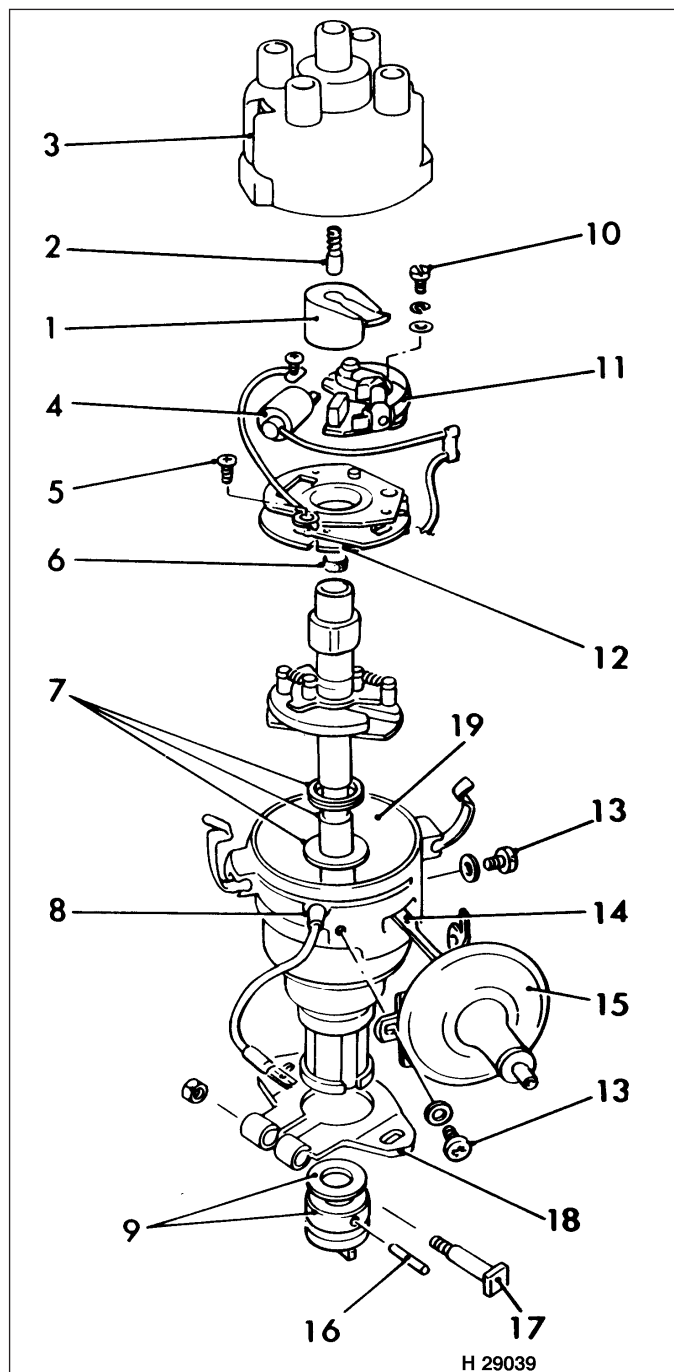

9.16 Exploded view of Lucas 45D4 distributor (59D4 similar)

- |   |   |
|---|---|
| 1 Rotor                                       | 10 Contact set securing screw               |
| 2 Carbon brush and spring                     | 11 Contact set                              |
| 3 Cap   | 12 Baseplate                                |
| 4 Condenser (capacitor)                       | 13 Vacuum unit retaining screws and washers |
| 5 Baseplate securing screw                    | 14 Vacuum unit link                         |
| 6 Felt pad                                    | 15 Vacuum unit                              |
| 7 Shaft assembly with steel washer and spacer | 16 Parallel pin                             |
| 8 Low tension lead and grommet                | 17 Pinch bolt and nut                       |
| 9 Drive dog and thrust washer                 | 18 Lockplate                                |
|   | 19 Distributor body                         |

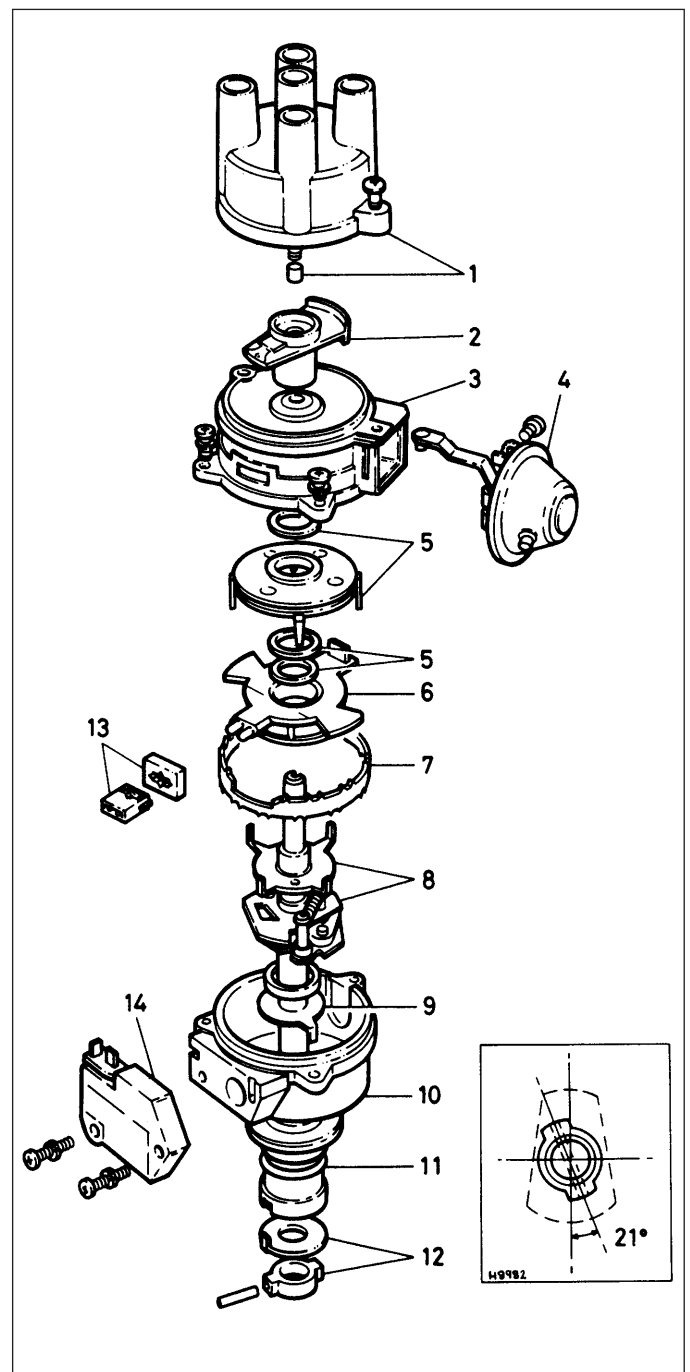

9.22 Exploded view of the Lucas 65DM4 electronic ignition distributor

- |  |  |
|--|--|
| 1 Distributor cap, carbon brush and spring | 8 Reluctor, centrifugal advance mechanism and shaft assembly |
| 2 Rotor arm                                | 9 Thrustwasher   |
| 3 Upper housing                            | 10 Lower housing   |
| 4 Vacuum unit                              | 11 O-ring  |
| 5 Stator pack, thrust washers and circlip  | 12 Drive dog and thrustwasher                                |
| 6 Pick-up winding                          | 13 Connector and gasket                                      |
| 7 Clamp ring                               | 14 Amplifier module  |
- Inset indicates correct rotor arm-to-drive dog offset (for carburettor models)

**10** With the cam spindle removed, the centrifugal advance weights can now be lifted out.

**11** To remove the vacuum unit, prise off the small circlip located behind the knurled adjustment wheel. Now unscrew the adjustment wheel until the vacuum unit is released and then withdraw the vacuum unit from the distributor body. **Note:** A vacuum unit is not fitted to the 23D4 type.

**12** As the unit is withdrawn, retrieve the adjustment wheel together with the tension spring and spring plate. The spring plate is responsible for the clicks when the adjustment wheel is turned. This spring plate together with the circlip are small and easily lost so put them in a safe place.

**13** It is only necessary to remove the distributor driveshaft if it is thought to be excessively worn. With a thin punch, drive out the retaining pin from the driving dog on the bottom end of the distributor driveshaft. The shaft can then be removed.

#### Lucas 45D4 and 59D4

**14** Remove the distributor from the car as described in Section 8.

**15** Withdraw the rotor arm from the distributor spindle and then remove the contact breaker points as described in Section 6.

**16** Push the low tension lead and grommet through into the inside of the distributor body (**see illustration**). Undo and remove the single retaining screw and lift off the condenser and low tension lead assembly. Note that the condenser securing screw also retains the baseplate earth lead.

**17** Undo and remove the two vacuum unit securing screws, tilt the vacuum unit to disengage the pullrod from the baseplate peg, and withdraw the unit.

**18** Undo and remove the two screws securing the baseplate and the earth lead to the distributor body. Lift off the earth lead, lever the slotted segment of the baseplate out of its retaining groove and withdraw the baseplate.

**19** The distributor driveshaft should only be removed if it is thought to be worn. After removal it cannot be further dismantled, and if necessary must be renewed as an assembly, complete with centrifugal advance weights and springs.

**20** To remove the driveshaft, drift out the retaining pin from the driving dog using a thin punch. Remove the driving dog and thrustwasher and then lift out the driveshaft assembly.

#### Lucas 65DM4

**21** Remove the distributor from the car as described in Section 8.

**22** Pull off the rotor arm (**see illustration**).

**23** Remove the two screws and pull the amplifier module from the connector, then remove the gasket and pull off the connector.

**24** Remove the screws, and separate the upper housing from the lower housing.

**25** Remove the clamp ring and pick-up winding from the upper housing.

**26** Remove the vacuum unit retaining screw, then extract the circlip and thrustwasher, withdraw the stator pack from the link arm, and remove the vacuum unit. Recover the remaining thrustwasher from the upper housing.

**27** Further dismantling is not normally necessary. However, the shaft assembly may be removed from the lower housing by driving the roll pin from the drive dog, after marking the drive dog in relation to the shaft.

**28** Clean and examine all the components, and renew them as required.

#### Ducellier

**29** Remove the distributor from the car as described in Section 8.

**30** Withdraw the rotor arm from the distributor spindle and then remove the contact breaker points as described in Section 6.

**31** Undo and remove the two screws that secure the condenser, vacuum unit, and one of the distributor cap retaining clips to the distributor body (**see illustration**). Lift away the condenser and clip.

**32** Using a small screwdriver, extract the circlip securing the serrated eccentric cam to the D-post. Mark the position of the eccentric cam in relation to the spring seat of the vacuum unit operating link.

**33** Detach the vacuum unit operating link and the eccentric cam from the D-post and lift off the vacuum unit. Store the eccentric cam and the small circlip safely, as they are easily lost.

9.31 Exploded view of Ducellier distributor

- 1 Cap
- 2 Rotor
- 3 Rocker arm clip
- 4 Moving contact assembly
- 5 Serrated cam
- 6 Eccentric D-post
- 7 Fixed contact
- 8 Baseplate
- 9 Felt pad
- 10 Cap retaining clips
- 11 Vacuum unit
- 12 Condenser

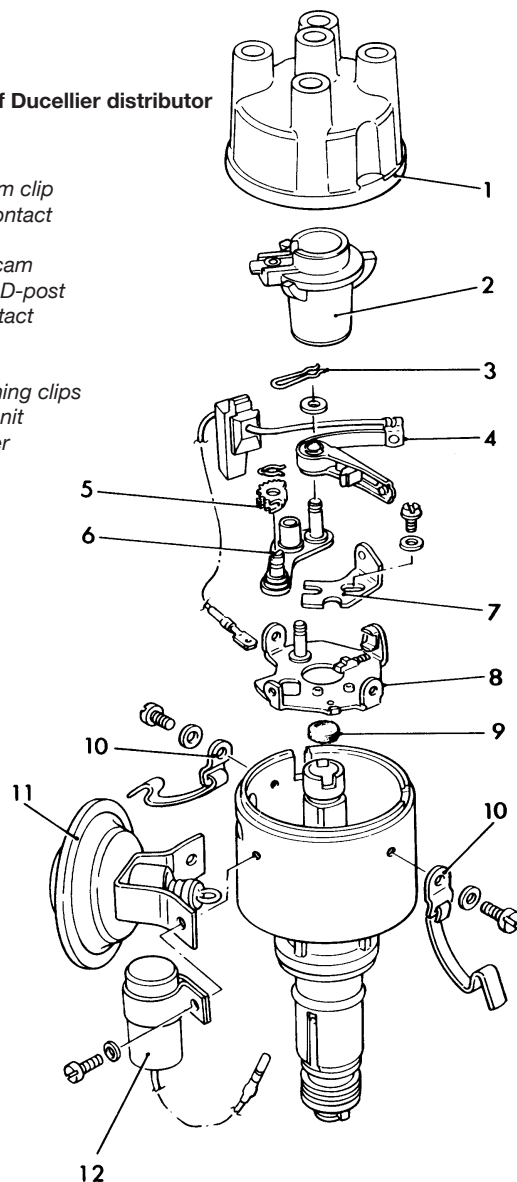

H13514



## 5B•14 Ignition system

**34** Undo and remove the screw securing the other distributor cap retaining clip and take off the clip.

**35** The distributor baseplate can now be removed, taking care not to allow the nylon pressure pad and spring to fly off as the baseplate is withdrawn.

**36** This is the limit of dismantling that can be carried out on these units. If the driveshaft, centrifugal advance weights or springs are thought to be worn, it will be necessary to obtain a complete new distributor assembly.

### Inspection

**37** Thoroughly clean all the mechanical parts in paraffin or a suitable solvent and wipe dry.

**38** Examine the contact breaker points as described in Section 5 and renew them if necessary.

**39** Check the distributor cap, HT leads and rotor arm as described in Chapter 1.

**40** Check the vacuum unit for leaks of the internal diaphragm, by sucking on the advance pipe union connection and observing the movement of the operating spring or arm. If, when suction is applied, a firm resistance builds up and the spring or arm moves in toward the diaphragm then the unit is satisfactory. If no resistance to suction is felt, and the operating spring or arm does not move, then it is likely that the diaphragm is punctured and the vacuum unit should be renewed.

**41** If working on a Lucas distributor, inspect the two halves of the baseplate. If the spring between the plates is damaged or if the two halves do not move freely, renew the baseplate.

**42** On all distributors, check for excessive side movement of the distributor shaft in the bushes. Any excess side play here can greatly affect the accuracy of the ignition timing and the overall performance of the car. If wear is apparent it will be necessary to renew the complete distributor.

**43** Examine the centrifugal advance weights and pivots for wear, and also check that the advance mechanism operates smoothly without binding. If these components are worn it will be necessary to renew the complete distributor in the case of the Ducellier unit, or the shaft assembly in the case of the Lucas 45D4. Advance weights and springs should be available separately for the Lucas 23D4 and 25D4 distributors.

### Reassembly

#### Lucas 23D4 and 25D4

**44** If the distributor shaft has been removed, lubricate the bearings in the distributor body with engine oil and refit the shaft. Position the thrustwasher and driving dog on the end of the shaft and tap in the retaining pin.

**45** Slide the vacuum advance unit into its location on the side of the distributor body. Place the spring plate in position, slide the adjustment wheel tension spring over the

threaded vacuum unit shaft, and then screw on the adjustment wheel.

**46** Set the position of the vacuum unit by rotating the adjustment wheel until approximately half the marks on the vacuum unit vernier scale are visible. Now refit the small circlip to the end of the shaft.

**47** Lay the centrifugal advance weights on the action plate of the distributor shaft. Lightly lubricate the shaft and the driving pins of the distributor spindle. Slide the spindle over the shaft and engage the driving pins with the advance weights. Check that when viewed from the base of the distributor, the large offset on the driving dog is to the left, with the rotor arm driving slot on the cam spindle uppermost. If this is correct, refit the spindle retaining screw. If not, reposition the spindle by 180°.

**48** Refit the two centrifugal advance weight tension springs to the posts on the action plate and spindle. Check the action of the weights by spinning the distributor shaft and ensure that they are not binding.

**49** Refit the baseplate and the two retaining screws, making sure that the earth lead is fitted under the head of the nearest screw. Reconnect the vacuum unit operating spring to the post on the baseplate.

**50** Refit the condenser and secure with the single retaining screw.

**51** Refit the contact breaker points as described in Section 6, and then place the rotor arm on the spindle.

**52** The distributor can now be refitted to the car as described in Section 8.

#### Lucas 45D4 and 59D4

**53** Begin reassembly by lubricating the distributor shaft assembly and sliding it into the distributor body.

**54** Place the thrustwasher and driving dog on the shaft, with the raised pips of the thrustwasher toward the driving dog. Position the driving dog so that the tongues are parallel with the rotor arm electrode, and the offset is to the left of its centre line with the rotor arm pointing upward (see illustration).

**55** Secure the driving dog with the retaining pin. If a new shaft is being fitted, it must be drilled through the hole in the driving dog to accept the retaining pin. The drill size will be either 3.175 mm or 4.762 mm, depending on the type of driving dog fitted. When drilling, keep the shaft pressed down into the distributor body, and the driving dog tight against the body shank. After fitting the retaining pin,peen over the edges of the hole in the driving dog slightly to secure the pin. Make sure that there is a trace of endfloat of the shaft when the driving dog is fitted. If necessary, tap the end of the driving dog to flatten the thrustwasher pips slightly and increase the endfloat.

**56** Position the baseplate on the distributor body so that the two downward pointing prongs straddle the screw hole below the distributor cap clip. Now press the baseplate into the body until it engages the undercut.

**57** Refit the baseplate retaining screws and the earth lead.

**58** Make sure that the baseplate prongs still straddle the screw hole and refit the vacuum unit. Engage the pullrod with the baseplate peg and secure the unit with the two screws.

**59** Slide the low tension lead assembly through the hole in the distributor body and fully engage the grommet. Position the condenser on the baseplate and secure it with the retaining screw. Make sure that the other end of the earth lead is positioned under the screw head.

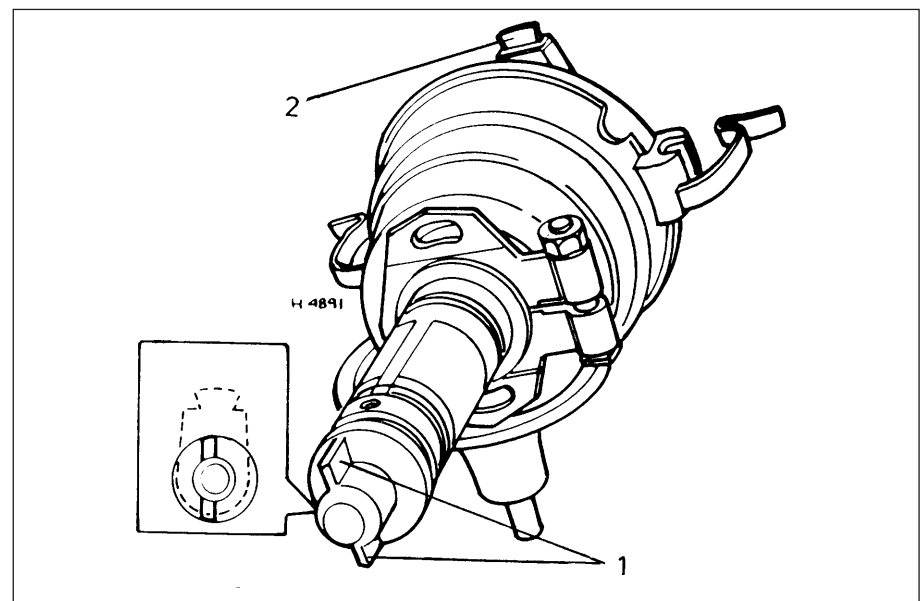

**9.54** Correct positioning of the distributor driving dog in relation to the rotor arm - Lucas 45D4 distributor

1 Driving dog tongues

2 Rotor arm

**60** Refit the contact breaker points as described in Section 6, and then place the rotor arm on the spindle.

**61** The distributor can now be refitted to the car as described in Section 8.

#### Lucas 65DM4

**62** Refit the shaft assembly if removed, locate the drive dog, and drive in the roll pin. Check that the drive dog offset is positioned correctly in relation to the rotor arm (see illustration 9.22).

**63** Lubricate the shaft bearing with a little engine oil. Also lubricate the centrifugal advance mechanism.

**64** Locate the thrustwasher in the upper housing.

**65** Grease the end of the link arm, then insert the vacuum unit in the upper housing, and engage the stator pack with the link arm. Retain the stator pack with the thrustwasher and circlip, and fit the vacuum unit retaining screw.

**66** Insert the pick-up winding in the upper housing, centralise the terminals in the aperture, then fit the clamp ring with the cut-out over the aperture.

**67** Fit the lower housing to the upper housing, and insert the screws finger-tight. Rotate the shaft several times, then fully tighten the screws.

**68** Check that the reluctor arms do not touch the stator pack arms, as they can easily be bent inadvertently.

**69** Fit the connector and gasket.

**70** Apply heat-conducting silicone grease to the mounting face of the amplifier module, then fit the module and tighten the screws. Refit the rotor arm.

**71** If necessary, renew the O-ring on the shank of the distributor, then refit the distributor, as described in Section 8.

#### Ducellier

**72** Lubricate the centrifugal advance weight pivot posts and the distributor cam sparingly with general purpose grease.

**73** Position the baseplate in the distributor body, making sure that the nylon pressure pad and spring are in place, with the pad in contact with the distributor shaft.

**74** Refit the distributor cap retaining clip, located opposite to the vacuum unit, and secure with the retaining screw.

**75** Position the operating link of the vacuum unit together with the eccentric cam, over the baseplate D-post. Turn the eccentric cam so that it is in the same position relative to the spring seat of the operating link, as marked during dismantling. Now carefully refit the small retaining circlip.

**76** Secure the vacuum unit, condenser, and the remaining distributor cap retaining clip to the distributor body, using the two screws.

**77** Refit the contact breaker points as described in Section 6, and then place the rotor arm on the spindle.

**78** The distributor can now be refitted to the car as described in Section 8.

## 10 Ignition coil - removal, testing and refitting



### Removal

**1** Release the fasteners, and remove the ignition shield from the front of the engine.

**2** Where applicable, slide back the rubber cover fitted over the end of the coil to expose the wiring connectors. Disconnect the LT wiring from the coil terminals, noting their positions. Disconnect the HT lead from the centre of the coil.

**3** If the coil is mounted on the dynamo, undo and remove the mounting bracket retaining bolts and lift off the coil. Slacken the clamp bolt and slide the coil out of its mounting bracket.

**4** If the coil is mounted on the cylinder head, slacken and remove the nut securing the coil to the cylinder head stud, and remove the coil and bracket assembly from the engine. If necessary disconnect the suppressor, then slacken the clamp bolt and slide the coil out of its mounting bracket.

### Testing

**5** Testing the coil consists of using a multimeter set to its resistance function, to check the primary (LT "+" to "-" terminals) and secondary (LT "+" to HT lead terminal) windings for continuity. If the meter is used, the resistance of either winding can be checked and compared with the specified value; note that although no specified value is given by Rover for the secondary windings, as a guide, the reading should be in the region of 5 to 15 kohms. The resistance of the coil windings will vary slightly according to the coil temperature; those specified are accurate only when the coil is at 20°C.

**6** Using an ohmmeter or continuity tester, check that there is no continuity between the HT lead terminal and the coil body.

**7** If the coil is faulty, it must be renewed. Ensure that the correct coil is obtained for the type of ignition system fitted.



**11.3** Crankshaft sensor wiring connector retaining bolt (arrowed) - manual transmission models

## Refitting

**8** Refitting is the reverse sequence to removal, ensuring that the wiring connectors are securely reconnected.

## 11 Crankshaft sensor (fuel injection models) - removal and refitting



### Removal

#### Manual transmission models

**1** Release the fasteners, and remove the ignition cover from the front of the engine. Disconnect the battery negative lead.

**2** Chock the rear wheels then jack up the front of the car and support it on axle stands (see "Jacking and vehicle support").

**3** Remove the tie securing the crankshaft sensor wiring to the starter motor solenoid, and undo the bolt securing the wiring connector to the mounting bracket (see illustration).

**4** Disconnect the sensor wiring connector, then undo the bolts securing the sensor to the flywheel housing, and remove the sensor from the car (see illustration).

#### Automatic transmission models

**5** Disconnect the battery negative lead, then undo the two bolts securing the ECU mounting bracket to the right-hand wing valance, and position the ECU clear of the crankshaft sensor.

**6** Undo the bolt securing the wiring connector to the mounting bracket, then disconnect the sensor wiring connector.

**7** Slacken and remove the two bolts securing the sensor to the torque converter housing, and remove the sensor from the car.

### Refitting

**8** On all models, refitting is the reverse sequence to removal, tightening the sensor mounting bolts to the specified torque.



**11.4** Crankshaft sensor location (arrowed) on manual transmission models - viewed from underneath

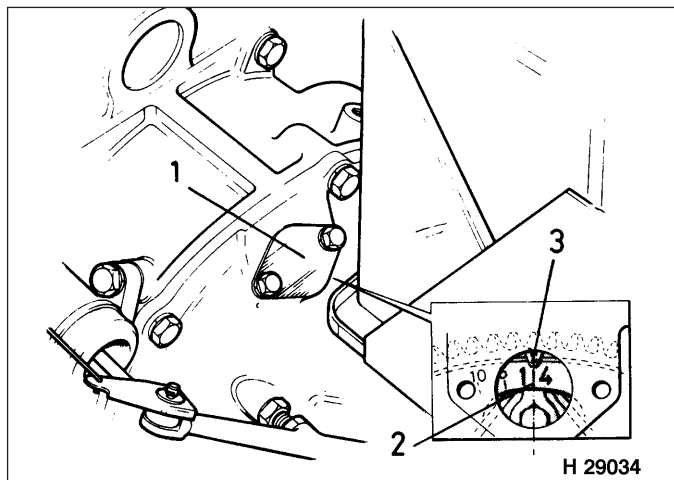

13.5a Ignition timing marks - manual transmission models

- 1 Inspection cover 2 Timing marks 3 Pointer

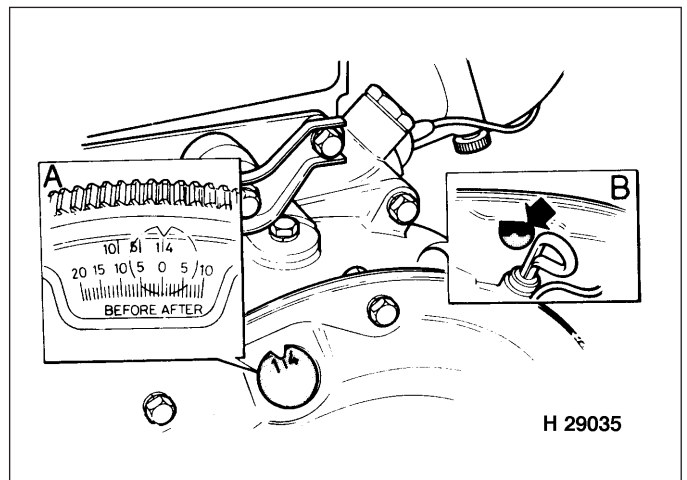

13.5b Location of timing marks on torque converter - automatic transmission models

- A Detail showing alternative timing marks B Insert screwdriver to turn converter

## 12 Reluctor ring (fuel injection models) - removal and refitting



### Manual transmission models

#### Removal

- 1 Remove the flywheel as described in Chapter 2A.
- 2 Slacken and remove the two retaining screws, and remove the reluctor ring from the rear of the flywheel.
- 3 Check the ring for obvious signs of wear or damage, and renew it if necessary.

#### Refitting

- 4 Refitting is the reverse sequence to removal, ensuring that the reluctor retaining screws are securely tightened.

### Automatic transmission models

- 5 On automatic transmission models, the reluctor ring is an integral part of the torque

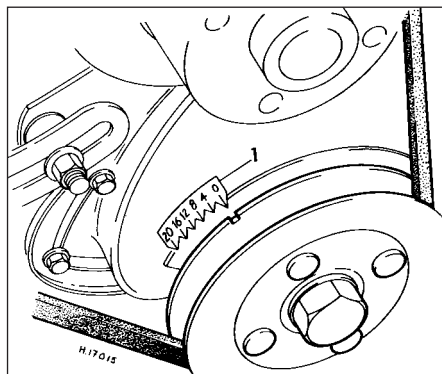

13.5c The timing scale located on the timing cover of later models

- 1 Timing scale

converter assembly, and is not available separately. Refer to Chapter 2A for information on torque converter removal and refitting. If the reluctor ring is damaged, the completed torque converter assembly must be renewed.

## 13 Ignition timing - checking and adjustment



### Carburettor models

- 1 In order that the engine can run efficiently, it is necessary for a spark to occur at the spark plug and ignite the fuel/air mixture at the instant just before the piston, on the compression stroke reached the top of its travel. The precise instant at which the spark occurs is determined by the ignition timing, and this is quoted in degrees before top dead centre (BTDC). On pre-1976 models the ignition timing may be checked with the engine stationary (this is the static ignition timing), or more accurately with the engine running, using a stroboscopic timing light. On post-1976 models a stroboscopic timing light must be used, as no static values are quoted by the manufacturer.

- 2 If the distributor has been dismantled or renewed, or if its position on the engine has been altered, it will be necessary to reset the ignition timing using the following procedure.

- 3 First ensure that the contact breaker points are in good condition and that the gap is correctly set as described in Section 5.

- 4 To obtain the static timing setting, remove the distributor cap and place it to one side. Gain access to the ignition timing marks by undoing the two bolts securing the inspection plate to the top of the flywheel housing and lifting off the plate. On models fitted with automatic transmission, withdraw the rubber

grommet from the top of the converter housing. On later models there is a timing scale on the timing cover, together with a notch or pointer on the crankshaft pulley.

- 5 The timing marks on the flywheel (or torque converter), and the pointer on the housing, can be viewed through the inspection aperture using a small mirror. The 1/4 mark on the flywheel or torque converter indicates TDC, and the 5, 10 and 15 marks indicate 5°, 10°, and 15° of advance before TDC respectively. On later models with a timing scale on the timing cover, each pointer on the scale represents 4° of ignition advance, with the larger pointer indicating TDC (see illustrations).

- 6 Refer to the *Specifications* at the beginning of this Chapter for the correct ignition timing static setting. The distributor number will be found stamped on the side of the distributor body, usually just below the vacuum unit (see illustration).

- 7 Having determined the correct setting, turn the engine over until No 1 piston is approaching TDC on the compression stroke. This can be checked by removing No 1 spark plug and feeling the pressure being developed in the cylinder as the piston rises, or by



13.6 The distributor number is stamped on the body below the vacuum unit

removing the rocker cover and noting when the valves of No 4 cylinder are rocking, ie the inlet valve just opening and the exhaust valve just closing. If this check is not made, it is all too easy to set the timing 180° out, as both No 1 and No 4 pistons approach TDC at the same time, but only one is on the compression stroke. On manual transmission models, the engine can be turned over quite easily by engaging top gear and moving the car forwards. This should only be done on level ground; and make sure that the car cannot run away! An alternative method, and the method that should be used on automatic transmission models, is to press the fan belt midway between the water pump pulley and dynamo or alternator pulley and then turn the fan blades.



**Turning the engine will be easier if the spark plugs are removed first - see Chapter 1.**

**8** Continue turning the engine, in the correct direction of rotation, until the appropriate timing mark on the flywheel or torque converter is in line with the pointer on the housing.

**9** The distributor rotor arm should now be pointing towards the No 1 spark plug HT lead segment in the distributor cap. Temporarily place the cap in position to verify this if necessary.

**10** With the engine set in the correct position and the rotor arm pointing towards the appropriate segment, turn the knurled vernier adjustment wheel, on the distributor (where applicable), until approximately half the marks on the vacuum unit timing scale are visible.

**11** Next slacken the distributor clamp plate pinch bolt and turn the distributor body clockwise until the points are *just* beginning to open. If they are already open, turn the distributor body anti-clockwise until they are fully closed, then turn it clockwise until they *just* begin to open. Now tighten the pinch bolt. If the distributor incorporates a knurled vernier adjustment wheel on the vacuum unit a very fine degree of accuracy can be obtained. Turning the wheel in the direction "A" stamped on the vacuum unit advances the timing, and turning it towards "R" retards it. Eleven clicks of the wheel represents 1° of timing movement and each graduation of the vernier scale is equal to approximately 5° of timing movement.

**12** Difficulty will probably be experienced in determining exactly when the contact breaker points open, so the following method can be used. Connect a 12 volt bulb in parallel with the contact breaker points (one lead to earth and the other to the distributor (-) low tension terminal on the coil). With the ignition switch on the bulb will light as the points open. The

distributor body should be turned as in paragraph 11 until the point is reached where the bulb *just* lights up.

**13** To adjust the ignition timing using a stroboscopic timing light, first connect the light in accordance with the manufacturer's instructions.

**14** Start the engine and allow it to reach normal running temperature.

**15** Refer to the *Specifications* for the appropriate ignition timing setting and the corresponding engine speed.

**16** Disconnect the vacuum advance pipe from the distributor and adjust the engine speed to that specified (see Chapter 4A).

**17** Remove the inspection cover from the flywheel or converter housing and shine the light beam into the aperture. Use a mirror to deflect the beam onto the flywheel or torque converter. On later models there is an additional and more easily visible timing scale on the timing cover, together with a notch or pointer on the crankshaft pulley

**18** Turn the knurled adjustment wheel or slacken the distributor clamp or pinch bolt and rotate the distributor body until the timing marks and pointer appear stationary and directly in line with each other.

**19** Tighten the clamp or pinch bolt, recheck that the timing is still correct, and then reconnect the vacuum pipe. After disconnecting the timing light, reset the engine idling speed to that specified (Chapter 4A).

**20** Whichever method has been used to set the ignition timing, a thorough road test should be carried out to ensure that the engine performance is satisfactory under all engine load conditions. As a general guide, the timing is correct if very slight "pinking" can be heard with the engine labouring (ie at the point where you would normally change to a lower gear). Any small corrections necessary can be made during the road test using the vernier adjustment wheel, or by turning the distributor body very slightly in the required direction.

### Fuel injection models

**21** While home mechanics with a timing light and a good-quality tachometer may be able to check the ignition timing, if it is found to be in need of adjustment, the car **must** be taken to a suitably-equipped Rover dealer; adjustments can be made only by re-programming the fuel injection/ignition system ECU, using Rover diagnostic equipment connected to the system by the diagnostic connector. Note also that the timing and idle speed are under ECU control and may, therefore, vary significantly from the nominal values given; without full equipment, any check is therefore nothing more than a rough guide.

## 14 Transmission-controlled ignition advance - checking and component renewal



**Note:** This procedure only applies to carburettor models.

### Checking

**1** To check the operation of the system, chock the front wheels, apply the handbrake and start the engine.

**2** Increase engine speed to approximately 2500 rpm.

**3** Depress and hold the clutch pedal down while selecting fourth gear.

**4** With fourth gear selected, engine speed should increase by 300 to 400 rpm.

**5** Disengage fourth gear, release the clutch pedal, and stop the engine.

**6** If the system does not respond as described, check the inhibitor switch adjustment as described below.

### Component renewal

#### Inhibitor switch

**7** Chock the rear wheels then jack up the front of the car and support it on axle stands (see "Jacking and vehicle support"). Place the gear lever in neutral.

**8** Disconnect the electrical leads from the inhibitor switch, located behind the gearchange remote control housing.

Slacken the locknut securing the switch to its mounting bracket then unscrew the switch from the bracket.

**9** Fit the switch to the mounting bracket and adjust as follows before tightening the locknut or reconnecting the leads.

**10** Connect a self-powered test lamp to the terminals of the inhibitor switch, and screw the switch out of its mounting bracket until the lamp lights.

**11** Now screw the switch in until the lamp goes out.

**12** Screw the switch in a further one and one half to two flats, then tighten the locknut.

**13** Check that the lamp lights only when the fourth gear is selected.

**14** Remove the test lamp, reconnect the electrical leads, and carry out the test procedure previously described.

#### Solenoid valve

**15** Pull the vacuum hoses from the solenoid valve.

**16** Disconnect the electrical leads.

**17** Remove the mounting screw, noting the earth lead, and remove the valve.

**18** Refitting is the reverse sequence to removal, ensuring that the earth lead is fitted under the mounting bolt.



# Chapter 9

## Braking system

### Contents

Brake disc - inspection, removal and refitting . . . . .	9	Hydraulic system - bleeding . . . . .	2
Brake drum - removal, inspection and refitting . . . . .	4	Master cylinder (single circuit system) - removal, overhaul and refitting . . . . .	12
Brake fluid level check . . . . .	See "Weekly checks"	Pressure differential warning actuator (dual circuit system) - removal, overhaul and refitting . . . . .	20
Brake fluid renewal . . . . .	See Chapter 1	Pressure reducing valve (dual circuit system) - removal and refitting . . . . .	19
Brake pad wear check . . . . .	See Chapter 1	Pressure regulating valve (single circuit system) - removal, overhaul and refitting . . . . .	18
Brake pedal - removal and refitting . . . . .	23	Tandem master cylinder (dual circuit system) - identification and modifications . . . . .	13
Brake shoe wear check . . . . .	See Chapter 1	Tandem master cylinder (type 1) - removal, overhaul and refitting . . . . .	14
Disc brake caliper - removal, overhaul and refitting . . . . .	8	Tandem master cylinder (type 2) - removal, overhaul and refitting . . . . .	15
Disc brake pads - renewal . . . . .	7	Tandem master cylinder (type 3) - removal, overhaul and refitting . . . . .	16
Drum brake adjustment . . . . .	See Chapter 1	Tandem master cylinder (type 4) - removal, overhaul and refitting . . . . .	17
Drum brake shoes - renewal . . . . .	5	Underbody and fuel/brake line check . . . . .	See Chapter 1
Drum brake wheel cylinder - removal, overhaul and refitting . . . . .	6	Vacuum servo unit - removal and refitting . . . . .	21
General information . . . . .	1	Vacuum servo unit air filter (1989 models onward) - renewal . . . . .	22
Handbrake adjustment . . . . .	See Chapter 1		
Handbrake cable - removal and refitting . . . . .	10		
Handbrake lever - removal and refitting . . . . .	11		
Hydraulic pipes and hoses - renewal . . . . .	3		

### Degrees of difficulty

<b>Easy</b> , suitable for novice with little experience 	<b>Fairly easy</b> , suitable for beginner with some experience 	<b>Fairly difficult</b> , suitable for competent DIY mechanic 	<b>Difficult</b> , suitable for experienced DIY mechanic 	<b>Very difficult</b> , suitable for expert DIY or professional 
---	--	--	---	--

### Specifications

#### System type

Footbrake . . . . .	Lockheed single or dual circuit hydraulic, servo assisted on certain models Mechanical by cables to rear brakes
Handbrake . . . . .	

#### Front drum brakes

Type . . . . .	Twin leading shoe
Drum diameter . . . . .	178.0 mm
Minimum brake shoe lining thickness . . . . .	3.0 mm

#### Front disc brakes

Type . . . . .	Disc with twin piston caliper
Disc diameter:	
Cooper S models . . . . .	190.5 mm
All other models . . . . .	213.4 mm
Maximum disc run-out . . . . .	0.15 mm
Minimum brake pad thickness . . . . .	3.0 mm

#### Rear brakes

Type . . . . .	Single leading shoe drum
Drum diameter . . . . .	178.0 mm
Minimum brake shoe lining thickness . . . . .	3.0 mm

#### Torque wrench settings

	Nm	lbf ft
Driveshaft retaining nut (disc brake models):		
With multiple split pin holes in driveshaft . . . . .	207	150
With single split pin hole in driveshaft . . . . .	255 to 270	188 to 200
Brake caliper retaining bolts . . . . .	52	38
Disc to hub flange . . . . .	57	42
Master cylinder body outlet plugs . . . . .	39	28
Master cylinder pressure differential piston end plug . . . . .	45	33
Pressure differential warning actuator end plug . . . . .	35	26
Pressure differential warning actuator failure switch . . . . .	19	14

## 1 General information

Drum brakes are fitted to the front and rear wheels on all early models except Cooper S and 1275 GT versions. These, and all later models have disc brakes at the front. The braking system is operated hydraulically by a master cylinder, which is actuated by the brake pedal. Disc brake models may also be servo assisted by a vacuum servo unit mounted in the engine compartment.

The hydraulic system on early models is of the single circuit type, whereby both the front and rear brakes are operated by the same hydraulic system from the master cylinder. On later models a dual circuit system is used, whereby the brakes at each pair of wheels are operated by a separate hydraulic system from a tandem master cylinder. In the event of hydraulic failure in one circuit, full braking force will still be available at two wheels. On early dual circuit systems a diagonal split is used, each circuit supplying one front and one diagonally opposite rear brake. Later versions employ a front-to-rear split whereby both front and both rear brakes are operated by a separate hydraulic circuit. A pressure differential warning actuator is fitted to certain models to inform the driver of a hydraulic circuit failure via an illuminated warning light, and also to restrict the flow of hydraulic fluid into the failed circuit. This unit is either mounted separately on the engine compartment bulkhead, or incorporated in the master cylinder. On single circuit and certain dual circuit systems, a pressure reducing valve is incorporated in the rear brake circuit. This valve reduces hydraulic fluid pressure to the rear brakes and prevents rear wheel lock-up due to forward weight transfer under heavy braking. On models not equipped with a pressure reducing valve, the same effect is achieved by reducing the rear wheel cylinder piston diameters. A low brake fluid warning light is also fitted to later models operated by a float-type switch in the master cylinder reservoir filler cap.

On models fitted with front drum brakes, the brake shoes are operated by two single piston wheel cylinders at each front wheel. Models with front disc brakes utilise a twin piston fixed type caliper at each front wheel. At the rear on all models, one twin piston wheel cylinder operates each wheel's leading and trailing brake shoes.

The handbrake provides an independent mechanical means of rear brake shoe application.

Adjustment of the drum brakes is provided by two adjusters on each front brake and a single adjuster on each rear brake. Periodic adjustment is necessary to compensate for wear on the brake shoe friction linings. The front disc brakes do not require adjustment, as the pistons in the caliper automatically compensate for brake pad wear.

**Note:** When servicing any part of the system, work carefully and methodically; also observe scrupulous cleanliness when overhauling any part of the hydraulic system. Always renew components (in axle sets, where applicable) if in doubt about their condition, and use only genuine Rover replacement parts, or at least those of known good quality. Note the warnings given in "Safety first" and at relevant points in this Chapter concerning the dangers of asbestos dust and hydraulic fluid.

## 2 Hydraulic system - bleeding



**Warning:** Hydraulic fluid is poisonous; wash off immediately and thoroughly in the case of skin contact, and seek immediate medical advice if any fluid is swallowed or gets into the eyes. Certain types of hydraulic fluid are inflammable, and may ignite when allowed into contact with hot components; when servicing any hydraulic system, it is safest to assume that the fluid IS inflammable, and to take precautions against the risk of fire as though it is petrol that is being handled. Hydraulic fluid is also an effective paint stripper, and will attack plastics; if any is spilt, it should be washed off immediately, using copious quantities of clean water. Finally, it is hygroscopic (it absorbs moisture from the air). The more moisture is absorbed by the fluid, the lower its boiling point becomes, leading to a dangerous loss of braking under hard use. Old fluid may be contaminated and unfit for further use. When topping-up or renewing the fluid, always use the recommended type, and ensure that it comes from a freshly-opened sealed container.

### General

1 The correct functioning of the brake hydraulic system is only possible after removing all air from the components and circuit; this is achieved by bleeding the system.

2 During the bleeding procedure, add only clean, fresh hydraulic fluid of the specified type; never re-use fluid that has already been bled from the system. Ensure that sufficient fluid is available before starting work.

3 If there is any possibility of incorrect fluid being used in the system, the brake lines and components must be completely flushed with uncontaminated fluid and new seals fitted to the components.

4 If brake fluid has been lost from the master cylinder due to a leak in the system, ensure that the cause is traced and rectified before proceeding further.

5 Park the car on level ground, switch off the ignition and select first gear (manual transmission) or Park (automatic transmission) then chock the wheels and release the handbrake.

6 Check that all pipes and hoses are secure, unions tight, and bleed screws closed. Remove the dust caps and clean any dirt from around the bleed screws.

7 Unscrew the master cylinder reservoir cap, and top-up the reservoir. Refit the cap loosely, and remember to keep the reservoir topped up throughout the procedure, otherwise there is a risk of further air entering the system.

8 There are a number of one-man, do-it-yourself, brake bleeding kits currently available from motor accessory shops. It is recommended that one of these kits is used wherever possible, as they greatly simplify the bleeding operation, and also reduce the risk of expelled air and fluid being drawn back into the system. If such a kit is not available, collect a clean glass jar of reasonable size and a suitable length of plastic or rubber tubing, which is a tight fit over the bleed screw.

9 If a kit is to be used, prepare the car as described previously, and follow the kit manufacturer's instructions, as the procedure may vary slightly according to the type being used; generally, they are as outlined in the text below.

10 The procedure for bleeding varies according to whether the car is equipped with a single or dual circuit braking system, and also with dual circuit systems, the type of master cylinder that is fitted. Identify the type of system being worked on by referring to the illustrations, and to Section 13, then proceed according to type.

### Single circuit system

11 To bleed the system, clean the area around the bleed screw of the wheel to be bled. If the hydraulic system has only been partially disconnected, and suitable precautions were taken to prevent further loss of fluid, it should only be necessary to bleed that part of the system. However, if the entire system is to be bled, proceed in the sequence ABCD for right-hand drive cars, and BADC for left-hand drive vehicles (see illustration).

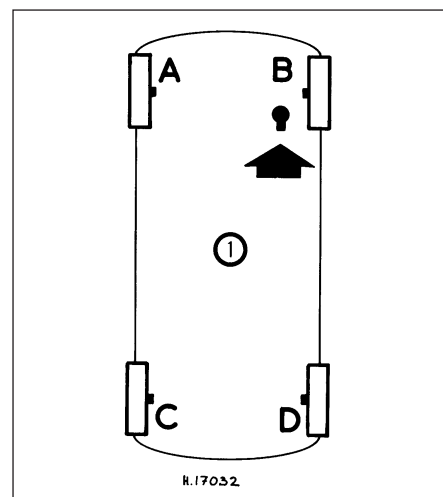

2.11 Bleeding sequence for single circuit braking systems



**2.13 One-man brake bleeding kit connected to the front bleed screw**

**12** Remove the master cylinder reservoir filler cap and top-up the reservoir. Periodically check the fluid level during the bleeding operation and top-up as necessary.

**13** If a one-man brake bleeding kit is being used, connect the outlet tube to the bleed screw (**see illustration**) and then open the screw approximately one turn. Position the unit so that it can be viewed from the car then depress the brake pedal to the floor and rapidly release it. The one-way valve in the kit will prevent expelled air from returning to the system at the end of each stroke. Repeat this operation until clean hydraulic fluid, free from air bubbles, can be seen coming through the tube. Then tighten the bleed screw and remove the outlet tube.

**14** If a one-man brake bleeding kit is not available, connect one end of the plastic tubing to the bleed screw and immerse the other end in the jar containing sufficient clean hydraulic fluid to keep the end of the tube submerged.

**15** Open the bleed screw approximately one turn and have your assistant depress the brake pedal to the floor, and then rapidly release it. Tighten the bleed screw at the end of each downstroke to prevent expelled air from being drawn back into the system.

**16** Repeat this operation until clean hydraulic fluid, free from air bubbles, can be seen coming through the tube. Then tighten the bleed screw on a downstroke and remove the plastic tube.

**17** If the entire system is being bled the procedures described previously should now be repeated at each wheel in the correct sequence.

**18** When completed, check the fluid level in the master cylinder, top-up if necessary, and refit the cap. Check the feel of the brake pedal, which should be firm and free from any sponginess; this would indicate air still present in the system.

**19** Discard any used hydraulic fluid, as the minute air bubbles and contamination which will be present in the fluid make it unsuitable for further use in the hydraulic system.

### Dual circuit system (early type)

**20** The following procedure is applicable to the type 1 tandem master cylinder (see Section 13) fitted to diagonally-split hydraulic systems.

**21** To bleed the system, clean the area around the bleed screws of the wheels to be bled. If only half of the hydraulic system has been disconnected, it should only be necessary to bleed that half, provided no air has entered the other half. However, if the entire system is to be bled, proceed in the sequence ABCD for right-hand drive cars and BADC for left-hand drive vehicles (**see illustration**).

**22** The procedure is now the same as described in paragraphs 12 to 19 for the single circuit system, except that the brake pedal should be depressed rapidly, held down for three seconds and then released slowly. A delay of fifteen seconds should then be allowed before repeating.

**23** When bleeding is complete, check the operation of the pressure differential warning actuator as described in Section 20.

### Dual circuit system (later type)

**24** The following procedure is applicable to the type 2, 3 and 4 tandem master cylinders (see Section 13) fitted to diagonally-split and front-to-rear split hydraulic systems.

**25** Before commencing the bleeding operation, unscrew the brake failure warning switch (where fitted) from the side of the master cylinder body. (No fluid loss will occur unless there is internal pressure differential piston seal failure.)

**Note:** *If the system is being bled following renewal of the master cylinder, check whether a plastic spacer is fitted between the pressure switch and master cylinder body. If a spacer is present, leave it in position during the bleeding operation and then discard it.*

**26** To bleed the system, clean the area around the bleed screws of the wheels to be bled. If only half of the hydraulic system has been disconnected, it should only be necessary to bleed that half, provided no air has entered the other half. However, if the entire system is to be bled, it must be done in the following sequence.

**27** For diagonally split systems, proceed in the order ABCD for right-hand drive cars, and CDAB for left-hand drive vehicles (**see illustration**).

**28** For front-to-rear split systems, proceed in the order ABCD, irrespective of driving position (**see illustration**).

**29** The procedure is now the same as described in paragraphs 12 to 19 for the single circuit system, except that the brake pedal should be depressed rapidly, held down for three seconds, and then released slowly. A delay of fifteen seconds should then be allowed before repeating.

**30** Where applicable, refit the brake failure warning switch and tighten it to the specified torque after completing the bleeding operation.

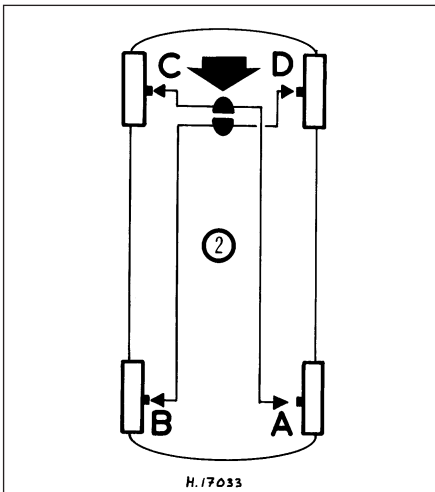

**2.21 Bleeding sequence for type 1 tandem master cylinder - see text**

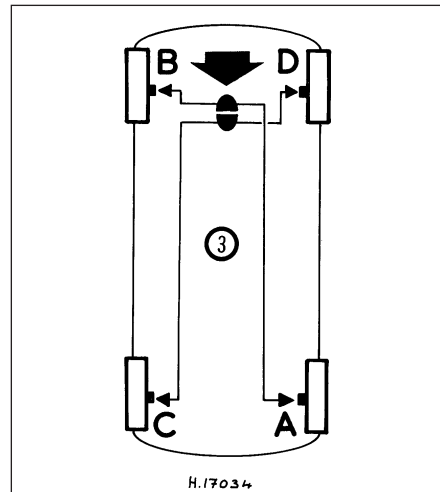

**2.27 Bleeding sequence for type 2, 3 and 4 tandem master cylinders with diagonal split braking systems - see text**

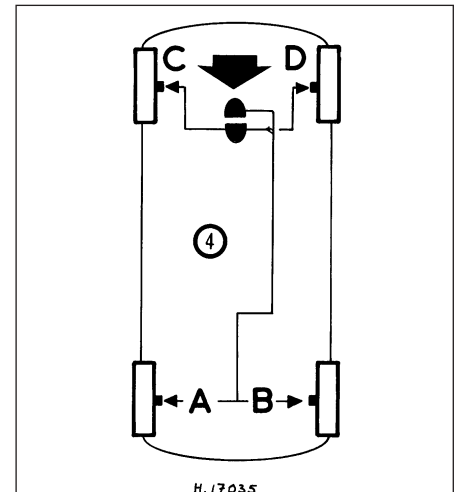

**2.28 Bleeding sequence for type 2, 3 and 4 tandem master cylinders with front-to-rear split braking systems - see text**

## 9•4 Braking system

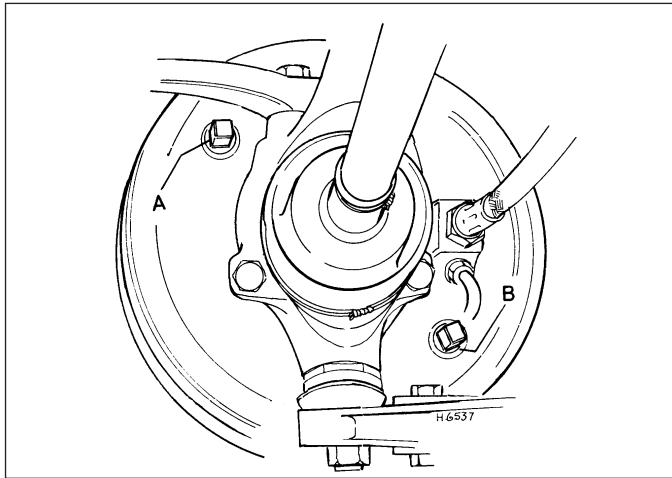

4.2a Location of the two front brake adjusters - A and B

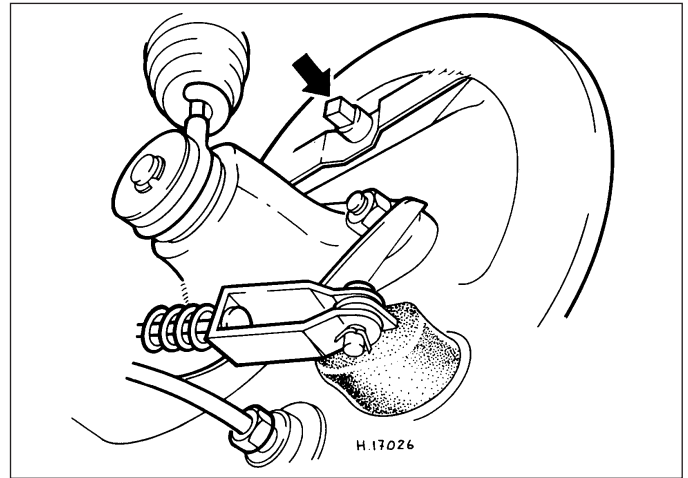

4.2b Location of the rear brake adjuster - arrowed

### 3 Hydraulic pipes and hoses - renewal



**Note:** Before starting work, refer to the warning at the beginning of Section 2 concerning the dangers of hydraulic fluid.

**1** If any pipe or hose is to be renewed, minimise hydraulic fluid loss by removing the master cylinder reservoir cap, placing a piece of plastic film over the reservoir and sealing it with an elastic band. Alternatively, flexible hoses can be sealed, if required, using a proprietary brake hose clamp; metal brake pipe unions can be plugged (if care is taken not to allow dirt into the system) or capped immediately they are disconnected. Place a wad of rag under any union that is to be disconnected, to catch any spilt fluid.

**2** If a flexible hose is to be disconnected, unscrew the brake pipe union nut before undoing the nut which secures the hose to its mounting. At the front, the other end of the hose will be screwed into its tapped hole in the wheel cylinder or brake caliper.

**3** To unscrew the union nuts, it is preferable to obtain a brake pipe spanner of the correct size; these are available from most large motor accessory shops. Failing this, a close-

fitting open-ended spanner will be required, though if the nuts are tight or corroded, their flats may be rounded-off if the spanner slips. In such a case, a self-locking wrench is often the only way to unscrew a stubborn union, but it follows that the pipe and the damaged nuts must be renewed on reassembly. Always clean a union and surrounding area before disconnecting it. If disconnecting a component with more than one union, make a careful note of the connections before disturbing any of them.

**4** If a brake pipe is to be renewed, it can be obtained, cut to length and with the union nuts and end flares in place, from Rover dealers. All that is then necessary is to bend it to shape, following the line of the original, before fitting it to the car. Alternatively, most motor accessory shops can make up brake pipes from kits, but this requires very careful measurement of the original, to ensure that the replacement is of the correct length. The safest answer is usually to take the original to the shop as a pattern.

**5** Before refitting, blow through the new pipe or hose with dry compressed air. Do not overtighten the union nuts. It is not necessary to exercise brute force to obtain a sound joint.

**6** If flexible rubber hoses are renewed, ensure that the pipes and hoses are correctly routed,

with no kinks or twists, and that they are secured in the clips or brackets provided.

**7** After fitting, bleed the hydraulic system as described in Section 2, wash off any spilt fluid, and check carefully for fluid leaks.

### 4 Brake drum - removal, inspection and refitting



**Note:** Before starting work, refer to the warning at the beginning of Section 5 concerning the dangers of asbestos dust.

#### Removal

**1** Chock the wheels then jack up the front or rear of the car as applicable and support it on axle stands (see "Jacking and vehicle support"). Remove the relevant roadwheels.

**2** Slacken off the brake shoe adjuster(s) from behind the backplate, then undo and remove the two brake drum retaining screws (see illustrations).

**3** Remove the brake drum from the wheel hub (see illustration). If the drum is tight, gently tap its circumference with a soft-faced mallet.

#### Inspection

**4** Brush the dust and dirt from the brake drum and carefully inspect the drum interior.

**5** If the drum is grooved, owing to failure to renew worn brake shoes or after a very high mileage has been covered, then it may be possible to grind it, provided the grooving is not excessive.

**6** Even if only one drum is in need of grinding both drums must be reground to the same size in order to maintain even braking characteristics.

**7** Judder or a springy pedal felt when the brakes are applied can be caused by a distorted (out-of-round) drum. Here again it may be possible to grind the drums, otherwise a new drum will be required.



4.2c Remove the brake drum retaining screws . . .



4.3 . . . and withdraw the drum



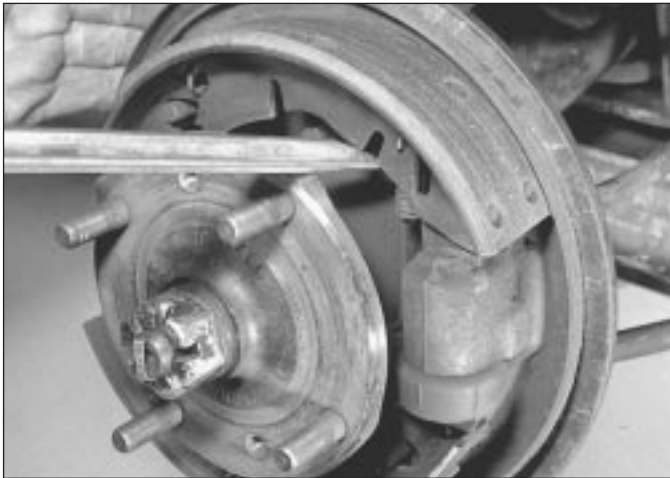

5.4a Remove the front brake shoes from the wheel cylinder pivot end first . . .



5.4b . . . and then from the piston end

### Refitting

8 Refitting is the reverse sequence to removal. Adjust the brakes as described in Chapter 1 before lowering the car to the ground.

## 5 Drum brake shoes - renewal



**Warning: Brake shoes must be renewed on both front or both rear wheels at the same time - never renew the shoes on only one wheel, as uneven braking may result. Also, the dust created by wear of the shoes may contain asbestos, which is a health hazard. Never blow it out with compressed air, and don't inhale any of it. An approved filtering mask should be worn when working on the brakes. DO NOT use petrol or petroleum-based solvents to clean brake parts; use brake cleaner or methylated spirit only.**

1 Remove the brake drum as described in Section 4.

2 Brush the dust and dirt from the shoes, backplate and drum.

3 Before removing the brake shoes, make a note of the positions of the shoes and the return springs and then remove the brake shoes as follows.

### Front brakes

4 First release the small hook springs (where fitted) securing the brake shoes to the wheel cylinder pistons. Now lift the end of each shoe off the pivot side of each wheel cylinder, and then the other end off the wheel cylinder pistons. Detach the return springs and withdraw the shoes (**see illustrations**).

5 If necessary, position a rubber band over the wheel cylinders to prevent the pistons coming out. Should there be evidence of brake fluid leakage from the wheel cylinder, renew it or overhaul it, as described in Section 6.

6 Refitting the front brake shoes is the reverse sequence to removal, bearing in mind the following points:

- Before refitting the shoes, smear a trace of high-melting-point brake grease to the pivot areas of the wheel cylinder, brake adjuster and backplate.
- Do not allow any grease or hydraulic fluid to come into contact with the brake shoe linings.

c) Ensure that the shoes are refitted correctly and the return springs are in their correct holes.

d) Repeat all the above operations on the opposite front brake.

e) With the brake shoes assembled and drums refitted, adjust the brakes as described in Chapter 1.

### Rear brakes

7 Lift the top of both shoes off the brake adjuster pivots and detach the top brake shoe return spring. Now lift the bottom of the front shoe off the wheel cylinder piston and disengage the handbrake operating lever (**see illustrations**). Repeat this for the rear shoe and lift away both shoes and lower return spring.

8 If necessary, position a rubber band over the wheel cylinders to prevent the pistons coming out. Should there be evidence of brake fluid leakage from the wheel cylinder, renew it or overhaul it, as described in Section 6.

9 Refitting the rear brake shoes is the reverse sequence to removal, bearing in mind the following points:

- Before refitting the shoes, smear a trace of high-melting-point brake grease to the pivot areas of the wheel cylinder, brake adjuster and backplate.



5.7a Withdraw the rear brake shoes from the brake adjuster pivots, detach the return spring . . .



5.7b . . . then lift off the front . . .



5.7c . . . and rear shoe from the handbrake lever and wheel cylinder

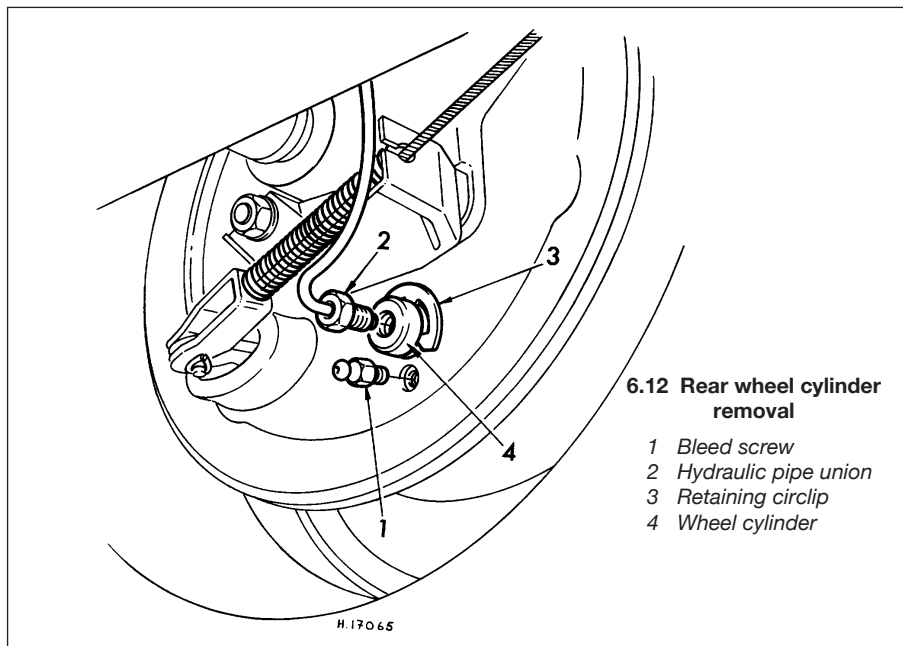

**6.12 Rear wheel cylinder removal**

- 1 Bleed screw
- 2 Hydraulic pipe union
- 3 Retaining circlip
- 4 Wheel cylinder

- b) Do not allow any grease or hydraulic fluid to come into contact with the brake shoe linings.
- c) Ensure that the shoes are refitted correctly and the return springs are in their correct holes. Ensure that the lower rear return spring does not rub on the wheel hub when refitted.
- d) Repeat all the above operations on the opposite rear brake.
- e) With the brake shoes assembled and drums refitted, adjust the brakes as described in Chapter 1.

**6 Drum brake wheel cylinder - removal, overhaul and refitting**



**Note:** Before starting work, refer to the warning at the beginning of Section 2 concerning the dangers of hydraulic fluid, and

to the warning at the beginning of Section 5 concerning the dangers of asbestos dust.

**Removal**

**Front wheel cylinder**

- 1 Remove the brake shoes from the relevant wheel as described in Section 5.
- 2 Thoroughly clean the rear of the backplate in the area around the wheel cylinder.
- 3 Clamp the flexible brake hose leading to the wheel cylinder with a proprietary brake hose clamp, or a self-gripping wrench with their jaws suitably protected. This will minimise hydraulic fluid loss when the hose or pipe is disconnected.
- 4 Disconnect the interconnecting brake pipe from the rear of the two wheel cylinders.
- 5 Undo and remove the two bolts securing each cylinder to the backplate.
- 6 If removing the cylinder containing the bleed screw, undo and remove the screw and lift off the cylinder.

7 If removing the cylinder containing the flexible brake hose, slacken the hose union at the wheel cylinder half a turn. Withdraw the wheel cylinder from the backplate and when it is clear, turn the cylinder anti-clockwise to unscrew it from the hose, taking care not to lose the copper sealing washer.

8 If the hose has not been clamped, suitably plug its end to prevent fluid loss and dirt ingress.

**Rear wheel cylinder**

9 Remove the brake shoes from the relevant wheel as described in Section 5.

10 Thoroughly clean the rear of the backplate in the area around the wheel cylinder.

11 Clamp the flexible hose located at the front of the rear suspension arm with a proprietary brake hose clamp, or a self-gripping wrench with its jaws suitably protected. This will minimise hydraulic fluid loss when the hydraulic pipe is disconnected.

12 Undo and remove the brake bleed screw and the hydraulic pipe union from the rear of the wheel cylinder (see illustration). Suitably protect the end of the brake pipe against dirt ingress.

13 Using a screwdriver, prise off the retaining circlip from the rear of the cylinder and then withdraw the wheel cylinder from the backplate.

**Overhaul**

14 Thoroughly clean off the exterior of the cylinder, then prepare a clean working area on the bench.

15 Lift off the rubber dust cover(s) from the end of the wheel cylinder and withdraw the piston(s) and rubber seal(s), noting their precise location in relation to each other (see illustrations).

16 Thoroughly wash the components in clean hydraulic fluid or methylated spirit and dry with a lint-free cloth.

17 Carefully inspect the surface of the piston(s) and the internal bore of the cylinder body for scoring, pitting or other signs of wear. If any of these conditions are apparent the cylinder must be renewed.

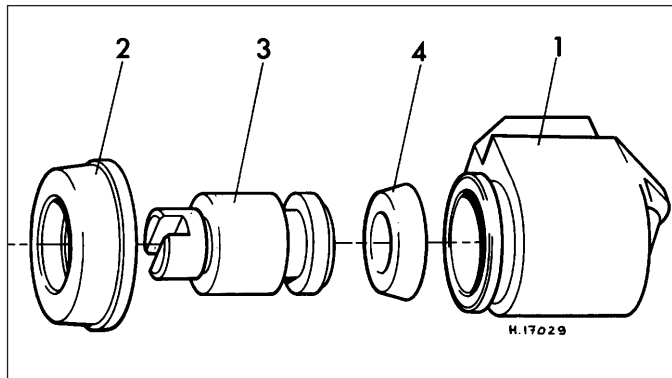

**6.15a Exploded view of a front wheel cylinder**

- 1 Cylinder body
- 2 Dust cover
- 3 Piston
- 4 Rubber seal

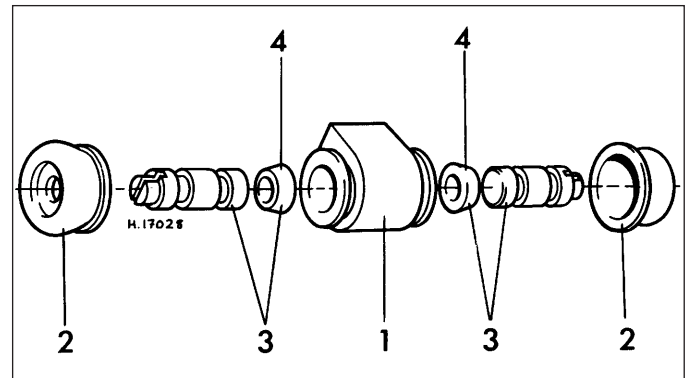

**6.15b Exploded view of a rear wheel cylinder**

- 1 Cylinder body
- 2 Dust covers
- 3 Piston assemblies
- 4 Rubber seals

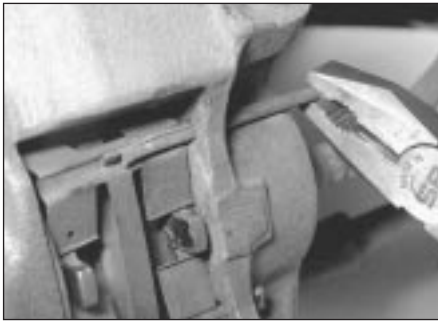

7.2 Extract the brake pad split pins from the caliper



7.3a Lift away the pad retaining spring plate . . .



7.3b . . . then withdraw the two brake pads

18 If the wheel cylinder is in a satisfactory condition, a new set of rubber seals should be obtained. Never re-use old seals as their condition is bound to be suspect.

19 To reassemble the wheel cylinder, immerse the piston and the new internal rubber seals in clean hydraulic fluid.

20 Carefully fit the seal(s) to the piston(s) with their lip or larger diameter facing away from the main part of the piston(s).

21 Slide the piston into the cylinder bore and then refit the dust cover(s) after first lubricating with the rubber grease supplied in the kit.

### Refitting

22 Refitting the front and rear wheel cylinders is the reverse sequence to removal, bearing in mind the following points:

- Where a wheel cylinder has been unscrewed from a flexible hose, use a new copper washer and ensure that the hose is not kinked when the cylinder is refitted.
- Ensure that the retaining spring circlip is correctly located in the groove in the rear wheel cylinder body.
- After fitting the wheel cylinder and refitting the brake shoes and drum, bleed the hydraulic system as described in Section 2. Providing the hoses were clamped as instructed, it should only be necessary to bleed the relevant wheel and not the entire system.



7.8 Smear high-temperature anti-seize grease to the pad backing plates

## 7 Disc brake pads - renewal



**Warning: Disc brake pads must be renewed on both front wheels at the same time - never renew the pads on only one wheel as uneven braking may result. Dust created by wear of the pads may contain asbestos, which is a health hazard. Never blow it out with compressed air and do not inhale any of it. DO NOT use petroleum-based solvents to clean brake parts. Use brake cleaner or methylated spirit only. DO NOT allow any brake fluid, oil or grease to contact the brake pads or disc. Also refer to the warning at the start of Section 2 concerning the dangers of hydraulic fluid.**

1 Chock the rear wheels then jack up the front of the car and support it on axle stands (see "Jacking and vehicle support"). Remove the front roadwheels.

2 Straighten the ends of the two brake pad retaining split pins then extract the split pins from the brake caliper (see illustration).

3 Lift away the pad retaining spring plate then, using a pair of pliers, carefully withdraw the two brake pads and (where fitted) their anti-rattle shims from the front of the caliper (see illustrations).

4 Carefully inspect the pads and renew them if the friction material has worn down to less than the minimum specified thickness.



7.10 Spread the ends of the split pins to retain them in position

5 Thoroughly clean all traces of dirt and dust from the recesses in the caliper, in which the brake pads lie, and the exposed face of each piston.

6 If new brake pads are being fitted it will be necessary to move the pistons back into the caliper to accommodate the new, thicker pads. This will cause a quantity of hydraulic fluid to be returned to the master cylinder reservoir, causing the fluid level to rise and possibly overflow. To protect the surrounding paintwork, remove the reservoir filler cap and place a large rag beneath the reservoir to absorb any fluid that may overflow. Alternatively, siphon off a quantity of fluid from the reservoir first.



**An ideal way to remove fluid from the master cylinder reservoir is to use a clean syringe or an old poultry baster.**

7 Using a flat bar or large screwdriver, lever the piston in each half of the caliper, back into its cylinder as far as it will go.

8 Smear a small amount of high-temperature anti-seize grease onto the edges and rear of the pad backing plates which contact the calipers and pistons (see illustration). Do not allow any grease onto the friction material of the brake pads.

9 Check that the cutaway face of each piston is facing upwards and then place the anti-rattle shims in position.

10 Slide in the brake pads, refit the pad retaining spring plate, then secure the assembly using new split pins. Spread the ends of the split pins to retain them in position (see illustration).

11 Depress the brake pedal several times (it will probably go right to the floor on the first stroke), to centralise the pads, and then check that the disc turns reasonably freely with the pedal released.

12 Repeat the above operations on the other front brake.

13 Refit the roadwheels and lower the car to the ground.



## 8 Disc brake caliper - removal, overhaul and refitting



**Note:** Before starting work, refer to the warning at the beginning of Section 2 concerning the dangers of hydraulic fluid, and to the warning at the beginning of Section 7 concerning the dangers of asbestos dust.

### Removal

- 1 Remove the disc brake pads as described in Section 7.
- 2 If the caliper is being removed for overhaul, slowly and carefully depress the brake pedal to bring the caliper pistons nearly into contact with the brake disc. This will assist subsequent removal of the pistons.
- 3 Using a proprietary brake hose clamp, or a self-gripping wrench with its jaws suitably protected, clamp the flexible brake hose leading to the caliper. This will eliminate any hydraulic fluid loss when the hose is disconnected.
- 4 Slacken the flexible hose union on the side of the caliper half a turn.
- 5 Undo and remove the two bolts securing the caliper to the swivel hub, and then withdraw the caliper forward and off the hub.
- 6 With the caliper clear of the hub and brake disc, support the flexible hose and turn the caliper anti-clockwise to unscrew it. With the hose disconnected, recover the copper sealing washer and plug its end to prevent dirt ingress.

### Overhaul

- 7 Carefully withdraw the two pistons one at a time from the caliper body. Do not attempt to separate the caliper halves.
- 8 Taking great care not to scratch the cylinder walls of the caliper, hook out the dust seal and piston seal from each caliper cylinder.
- 9 Thoroughly clean the caliper and pistons in clean hydraulic fluid or methylated spirit and dry with a lint-free cloth.
- 10 Inspect the pistons and caliper bores in the caliper for wear, score marks or surface pitting, and if evident renew the complete caliper assembly.
- 11 If the caliper and pistons are in a satisfactory condition, a new set of seals should be obtained. *Never re-use old seals.*
- 12 Lubricate the pistons, seals and the cylinder bores in the caliper with clean hydraulic fluid.
- 13 Insert the piston seal into the groove in the caliper and then insert the piston with the cutaway facing upwards.
- 14 Push the piston into its cylinder until 8.0 mm remains protruding.
- 15 Now carefully insert the dust seal into the outer groove in the caliper and push it squarely into place.
- 16 Repeat paragraphs 13, 14 and 15 for the other piston.

## Refitting

17 Refitting the brake caliper is the reverse sequence to removal, bearing in mind the following points:

- a) Use a new copper washer on the flexible brake hose and ensure that with the caliper in position, the hose is not kinked or twisted.
- b) Tighten the caliper retaining bolts to the specified torque.
- c) Refit the brake pads as described in Section 7 then bleed the hydraulic system as described in Section 2. If the flexible hose was clamped as described, it should not be necessary to bleed the entire system.

## 9 Brake disc - inspection, removal and refitting



**Note:** Before starting work, refer to the warning at the beginning of Section 7 concerning the dangers of asbestos dust.

### Inspection

**Note:** If a disc requires renewal, BOTH discs should be renewed at the same time to ensure even and consistent braking. New brake pads should also be fitted.

- 1 Remove the disc brake pads as described in Section 7.
- 2 Inspect the disc friction surfaces for cracks or deep scoring (light grooving is normal and may be ignored). A cracked disc must be renewed; a scored disc can often be reclaimed by machining provided that the thickness is not significantly reduced. Consult your Rover dealer as to the best course of action if deep scoring is evident.
- 3 Check the disc run-out using a dial test indicator with its probe positioned near the outer edge of the disc. If the run-out exceeds the figures given in the *Specifications*, machining may be possible, otherwise disc renewal will be necessary.



**If a dial test indicator is not available, check the run-out by positioning a fixed pointer near the outer edge, in contact with the disc face. Rotate the disc and measure the maximum displacement of the pointer with feeler blades.**

4 Excessive disc thickness variation can also cause judder. Check this using a micrometer. No actual thickness variation figures are provided by the manufacturer, but as a general guide, 0.010 mm should be considered a maximum.

### Removal

5 If not already done, chock the rear wheels then jack up the front of the car and support it

on axle stands (see “*Jacking and vehicle support*”). Remove the front roadwheel.

6 Extract the split pin from the driveshaft retaining nut. If the brake pads have not been removed, have an assistant firmly depress the brake pedal, while you undo and remove the driveshaft nut using a socket and extension bar. Remove the split-collar located behind the driveshaft nut. If the brake pads have already been removed for disc inspection, temporarily refit them to allow the driveshaft nut to be undone or, alternatively, fabricate a home-made tool to prevent the hub flange rotating when undoing the nut (see Chapter 8, Section 2). Note that on later models, the driveshaft retaining nut is extremely tight and it may be beneficial to use the home-made tool even if the pads are still fitted.

7 Undo and remove the brake caliper retaining bolts. Lift off the caliper complete with brake pads (where applicable), and with the brake hose still attached, and tie it out of the way from a convenient place under the wheel arch. Take care not to stretch the flexible hose.

8 Withdraw the front hub flange and brake disc from the swivel hub and driveshaft.

9 To separate the disc from the hub flange, first mark the two components to ensure that they are refitted in the same position.

10 Undo and remove the bolts securing the hub flange to the disc and lift away the disc.

### Refitting

11 Ensure that the mating surfaces between disc and hub flange are thoroughly clean then place the disc in position and refit the retaining bolts. If the original disc is being refitted, ensure that the marks made on removal are aligned.

12 Locate the hub flange and disc assembly over the driveshaft and in position on the swivel hub. Smear engine oil over the driveshaft threads and fit the split-collar and driveshaft retaining nut. Tighten the nut finger tight only at this stage.

13 Refit the brake caliper and secure with the two bolts tightened to the specified torque.

14 If removed, refit the brake pads as described in Section 7.

15 Using the same procedure as for removal to prevent the hub rotating, tighten the nut to the specified torque. Note that there are two different torque settings for the driveshaft nut; one for driveshafts with multiple split pin holes, and a higher setting for driveshafts with a single split pin hole. Tighten the nut further to align the split pin holes in the driveshaft and nut, then secure the nut with a new split pin.

16 Refit the roadwheel and lower the car to the ground.





10.7 Removing the handbrake cable from the moving sector



10.10 Pinching the ends of the moving sector to retain the handbrake cable

## 10 Handbrake cable - removal and refitting



### Early models

#### Removal

- 1 Chock the front wheels then jack up the rear of the car and support it on axle stands (see "Jacking and vehicle support"). Remove the rear roadwheel and ensure that the handbrake is off.
- 2 From inside the car, undo and remove the cable adjusting nut at the handbrake lever, then pull the cable out of the lever trunnion. Slide the two washers and tension spring off the threaded end of the cable.
- 3 Lift up the carpets to expose the cable

guide plates located at the point where the cable passes through the floor.

4 Engage the help of an assistant to hold the two nuts from underneath the car while the two cable guide retaining screws are removed from above. Lift off the guide and sealing pad.

5 From beneath the car, pull the end of the cable through the opening in the floor and out of the passenger compartment.

6 Bend back the tags slightly on the guide channel located on the forward crossmember of the rear subframe. Lift the cable out of the guide channel.

7 Similarly bend up the pinched ends of the moving sector located at the front of the rear suspension arm. Lift the cable and the locating peg out of the sector (see illustration), and then pull the disconnected end of the cable through the opening in the side of the subframe.

8 At the other end of the cable, extract the split pin and withdraw the clevis pin securing the cable end to the handbrake operating arm.

9 Release the cable from the abutment bracket at the rear of the brake backplate and lift the cable off the car.

#### Refitting

10 Refitting the cable is the reverse sequence to removal, bearing in mind the following points:

- a) With the cable in position, pinch the ends of the moving sector and subframe guide channel slightly to retain the cable (see illustration).
- b) Ensure that the guide channel in the subframe is well lubricated.
- c) Adjust the handbrake as described in Chapter 1 on completion.

### Later models - front cable

#### Removal

11 Chock the front wheels then jack up the rear of the car and support it on axle stands (see "Jacking and vehicle support"). Remove the rear roadwheel and ensure that the handbrake is off.

12 Tilt the front seats forward and lift up the carpet around the handbrake lever.

13 Slacken the locknut, and then unscrew the cable adjusting nut until the cable can be withdrawn from the lever assembly (see illustration).

### 10.13 Handbrake cables and lever assembly fitted to later models

- A Front cable adjustment detail
- B Rear cable and compensator detail
- C Compensator
- D Front cable
- E Rear cable

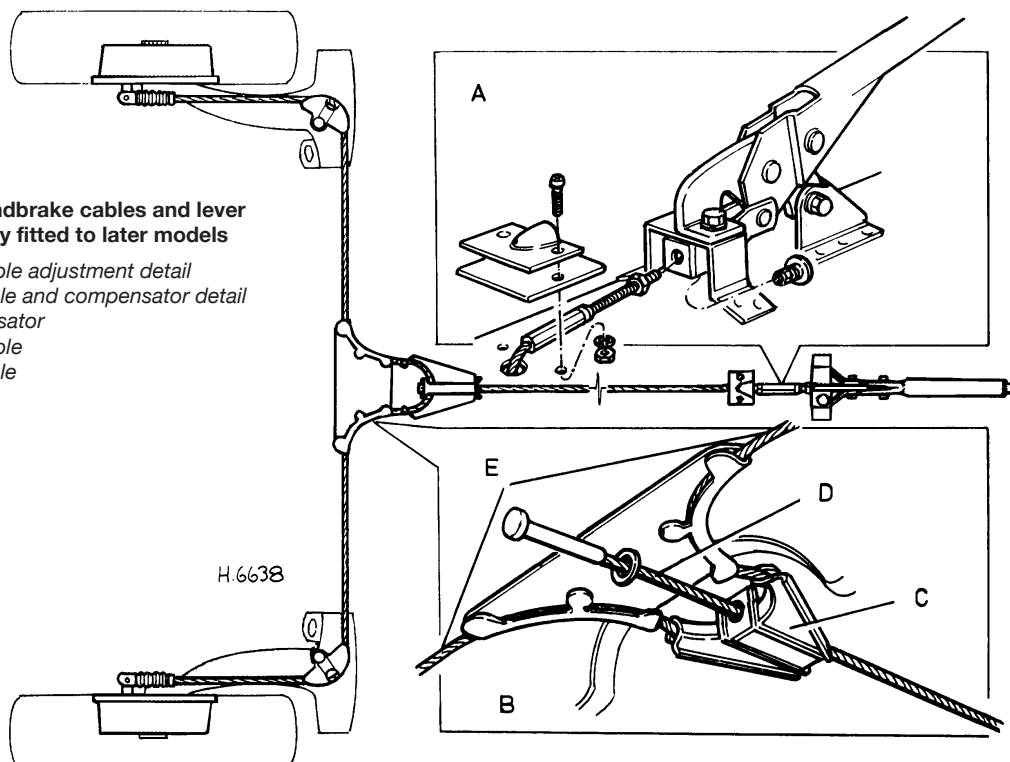

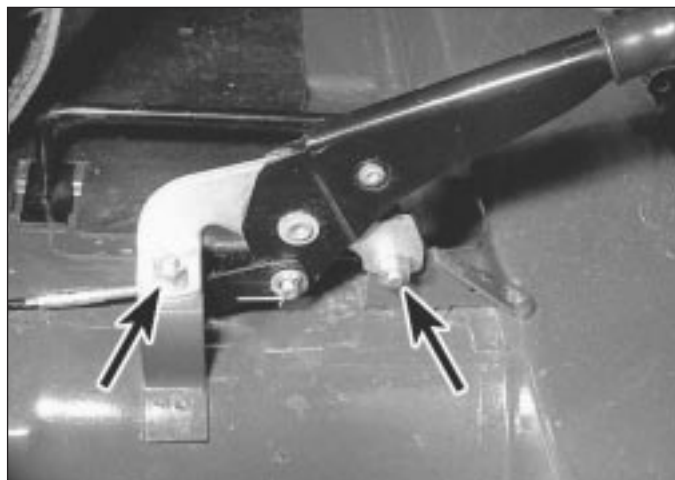

11.2 Handbrake lever retaining nuts and bolts

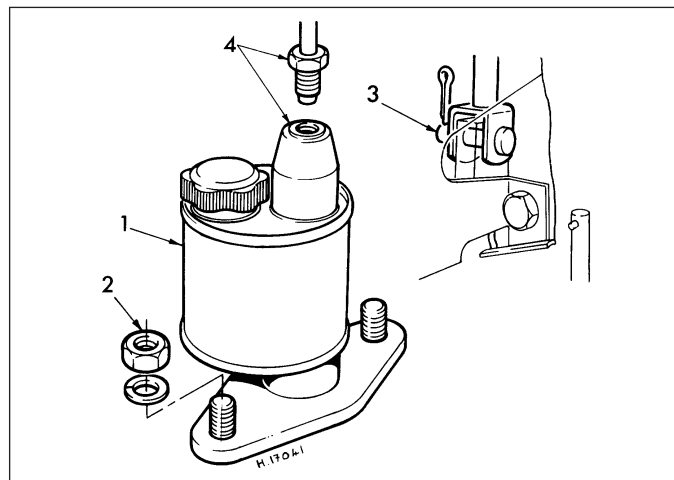

12.2 Removal of the single circuit master cylinder

- |                   |                                     |
|-------------------|-------------------------------------|
| 1 Master cylinder | 3 Pushrod-to-brake pedal attachment |
| 2 Retaining nuts  | 4 Hydraulic pipe union              |

14 Undo and remove the screws securing the cable guide plate to the floor. Have an assistant hold the two nuts from under the car as the screws are undone.

15 Lift off the guide plate and pass the cable through the hole in the floor.

16 Pull the cable rearwards and remove it from the compensator on the rear cable.

#### Refitting

17 Refitting is the reverse sequence to removal. Adjust the handbrake as described in Chapter 1 on completion.

#### Later models - rear cable

#### Removal

18 Remove the front cable as described previously.

19 Extract the split pins and withdraw the clevis pins securing the cable ends to the handbrake operating arms at the rear of each brake backplate. Release the cable and tension springs from the abutment brackets on the backplate.

20 Bend back the tags slightly on the guide channels located on the forward crossmember of the rear subframe.

21 Similarly bend up the pinched ends of the moving sectors located at the front of each rear suspension arm. Lift the cable and locating pegs out of the sectors, pull the disconnected ends of the cable through the openings in the side of the subframe, and lift away the cable complete with compensator.

#### Refitting

22 Refitting the rear cable is the reverse sequence to removal bearing in mind the following points.

- With the cable in position pinch the ends of the moving sectors and subframe guide channels slightly to retain the cable.
- Ensure that the guide channels in the subframe are well lubricated.

### 11 Handbrake lever - removal and refitting



#### Removal

1 On early models lift up the front seats, unscrew the two handbrake cable adjusting nuts and pull the cables out of the trunnion on the lever. On later models slacken the locknut, unscrew the cable adjusting nut and withdraw the cable.

2 Undo and remove the two nuts, bolts and spring washers securing the handbrake lever to the bracket on the floor (see illustration). Lift off the lever and withdraw it from the car.

3 The handbrake lever cannot be dismantled, and if worn or faulty must be renewed as a complete assembly.

#### Refitting

4 Refitting is the reverse sequence to removal. Adjust the handbrake as described in Chapter 1 on completion.

### 12 Master cylinder (single circuit system) - removal, overhaul and refitting



**Note:** Before starting work, refer to the warning at the beginning of Section 2 concerning the dangers of hydraulic fluid.

#### Removal

1 From inside the car release the heater air inlet ducting from the side of the heater unit and wheel arch. Remove the ducting from under the parcel shelf.

2 Extract the split pin and withdraw the clevis pin securing the master cylinder pushrod to the brake pedal (see illustration).

3 Working in the engine compartment, unscrew the brake pipe union from the top of the master cylinder and carefully pull the pipe clear.

4 Undo and remove the two nuts and spring washers securing the master cylinder to the bulkhead and lift off the cylinder.

#### Overhaul

5 Remove the filler cap from the master cylinder then drain and discard the hydraulic fluid from the reservoir.

6 With the cylinder on the bench, withdraw the rubber dust cover and slide it off over the end of the pushrod (see illustration).

7 Using circlip pliers, extract the circlip and lift off the pushrod and dished washer.

8 Tap the master cylinder body on a block of wood until the piston emerges from the end of the cylinder bore.

9 Withdraw the piston from the cylinder, followed by the piston washer, main cup seal, spring retainer, spring and non-return valve.

10 Lay the parts out in the order of removal, and then very carefully remove the secondary cup seal from the piston by stretching it over the end of the piston.

11 Wash the components in clean hydraulic fluid or methylated spirit and dry with a lint-free rag.

12 Examine the cylinder bore and piston carefully for signs of scoring, or wear ridges. If these are apparent, renew the complete master cylinder. If the condition of the components appears satisfactory, a new set of rubber seals must be obtained. *Never reuse old seals* as they will have deteriorated with age even though this may not be evident during visual inspection.

13 Begin reassembly by thoroughly lubricating the internal components and the cylinder bore in clean hydraulic fluid.

### 13 Tandem master cylinder (dual circuit system) - identification and modifications

#### Identification

**1** Four different versions of tandem brake master cylinder have been fitted to Mini models covered by this manual. The removal, refitting and overhaul procedures for the four versions are distinctly different and it is important to correctly identify the unit being worked on before proceeding.

**2** For identification purposes only, the master cylinders will be referred to in this Chapter as types 1, 2, 3 or 4. Identification is as follows:

*Type 1: Vertically mounted and incorporating a circular plastic transparent fluid reservoir with large flat filler cap (see illustration). Separate pressure differential warning actuator located on engine compartment bulkhead.*

*Type 2: Vertically mounted and incorporating a rectangular plastic transparent fluid reservoir with small flat filler cap possibly with brake fluid level warning indicator. Upper and lower hydraulic pipe union nuts of the same size. Pressure differential warning actuator integral with master cylinder, operating a brake failure warning switch fitted to the side of the cylinder body (see illustration).*

*Type 3: Vertically mounted and incorporating a rectangular plastic transparent fluid reservoir with brake fluid level warning indicator in the filler cap. Upper hydraulic pipe union nut larger than the lower nut. A yellow plastic identification band should also appear around the cylinder body (see illustration). Fitted to models manufactured from November 1985 to 1989 and as a retro-fit replacement for type 2 units.*

*Type 4: Horizontally mounted on the front of the vacuum servo unit. Fitted to models manufactured from 1989 onwards (see illustration).*

#### Modifications

**3** In November 1985, the type 3 tandem master cylinder with a revised front/rear split was introduced to replace the type 2. This new cylinder has a stepped bore, and the primary and secondary circuits have been reversed.

**4** Should a type 2 master cylinder require renewal, a type 3 unit will be supplied by Rover dealers.

**5** To fit the type 3 cylinder to pre-November 1985 vehicles, two modified brake pipes will be required and, on vehicles without a brake fluid level warning indicator, a conversion wiring loom will also be required. These modified components should be available from Rover dealers.

**6** To fit a type 3 master cylinder to pre-November 1985 vehicles, proceed as follows.

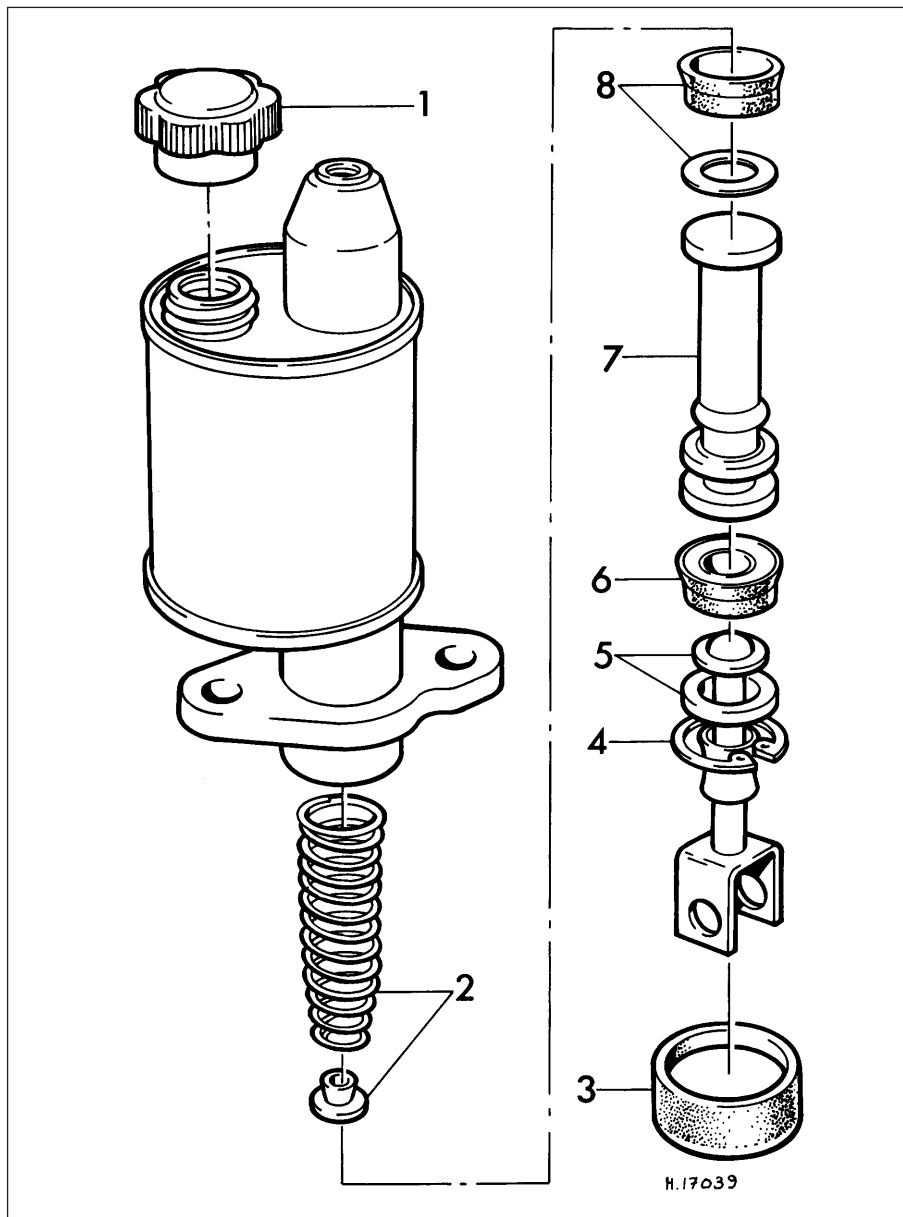

12.6 Exploded view of the single circuit master cylinder

- |                              |                                   |
|------------------------------|-----------------------------------|
| 1 Filler cap                 | 5 Pushrod and stop washer         |
| 2 Spring and spring retainer | 6 Secondary cup seal              |
| 3 Dust cover                 | 7 Piston                          |
| 4 Circlip                    | 8 Piston washer and main cup seal |

**14** Using fingers only, place the secondary cup seal in position on the piston with the lip of the cup facing the opposite (drilled) end of the piston.

**15** Position the non-return valve over the larger diameter of the spring and the spring retainer over the smaller diameter, and place this assembly into the cylinder bore, larger diameter first.

**16** Now insert the main cup seal into the cylinder bore, lip end first followed by the washer.

**17** Insert the piston assembly into the cylinder bore followed by the pushrod, dished washer and circlip. Ensure that the circlip fully enters its groove.

**18** Lubricate a new dust cover with rubber grease and stretch it over the pushrod and into position on the end of the cylinder.

#### Refitting

**19** Refitting is the reverse sequence to removal. Bleed the complete hydraulic system as described in Section 2 on completion.

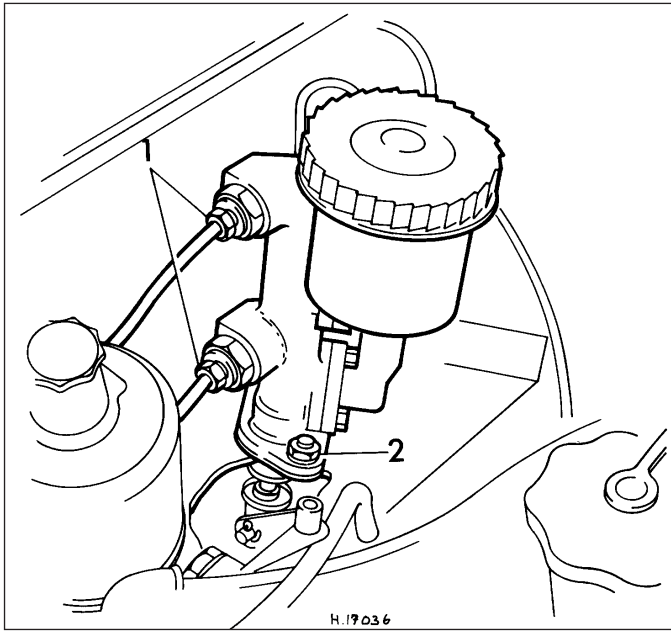

**13.2a Identification and removal of the type 1 tandem master cylinder**

- 1 Hydraulic pipe unions      2 Retaining nuts

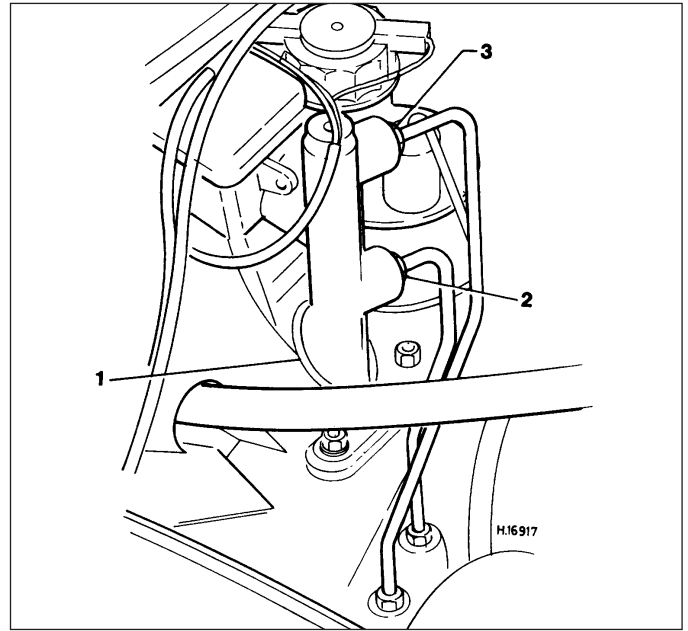

**13.2c Identification and removal of the type 3 tandem master cylinder**

- 1 Yellow band      2 Larger pipe union      3 Smaller pipe union

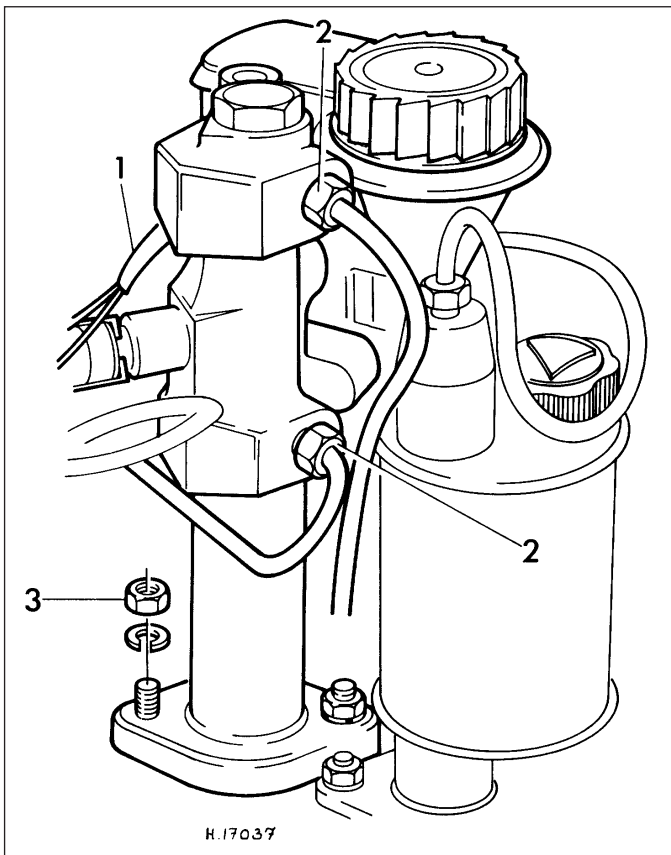

**13.2b Identification and removal of the type 2 tandem master cylinder**

- 1 Electrical wiring to failure switch      2 Hydraulic pipe unions  
3 Retaining nuts

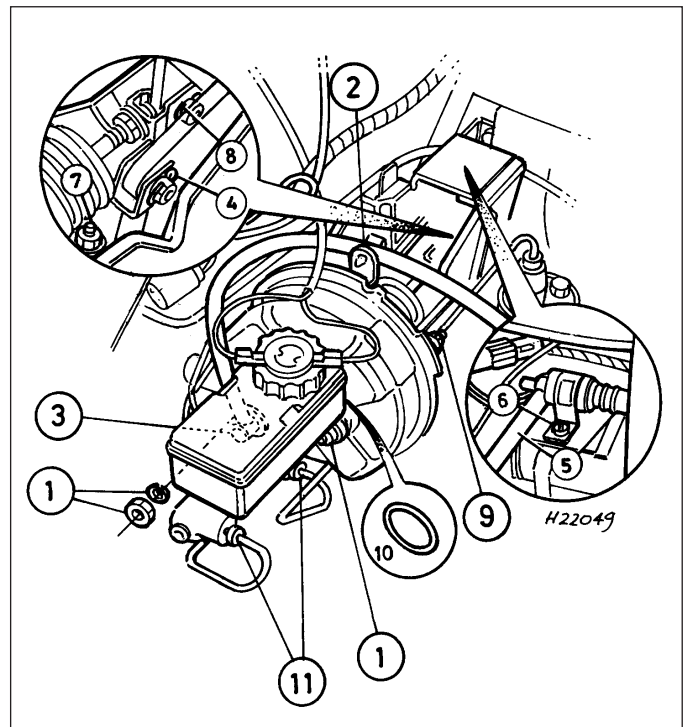

**13.2d Identification and removal of the type 4 tandem master cylinder**

- 1 Master cylinder mounting nuts      7 Servo mounting bracket nuts  
2 Vacuum hose retaining clip      8 Servo pushrod clevis pin  
3 One-way vacuum valve      9 Servo-to-mounting bracket nuts  
4 Brake pedal clevis pin      10 O-ring  
5 Anti-run-on valve hoses (where fitted)      11 Brake pipe union nuts  
6 Anti-run-on valve (where fitted)



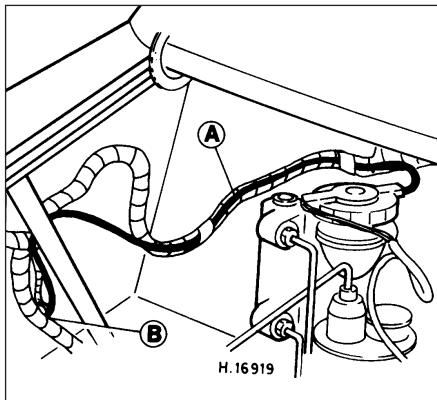

**13.11 Braking system conversion wiring loom details**

A Loom B Earth screw

**7** Remove the master cylinder, as described in Section 15. **Note:** On vehicles equipped with a fluid level indicator, disconnect the wiring connectors from the switch on the reservoir filler cap.

**8** Remove the existing hydraulic pipes from the pressure-reducing valve (which run to the brake master cylinder).

**9** Fit the new pipes to the pressure reducing valve.

**10** Fit the new brake master cylinder, which is a reversal of removal, then connect the new pipes to it.

**11** To fit the wiring conversion loom, first cut the connector from the end of the two black and white wires removed from the brake warning switch on the old cylinder (see illustration).

**12** Join the two wires together, fit a Lucar connector, and connect it to one terminal of the fluid level warning switch on the new master cylinder.

**13** Using black cable, make up an earth lead with a Lucar connector at one end and an eyelet at the other.

**14** The earth lead should be 533.0 mm long, and is connected to the other connector on the fluid level warning switch, and routed along the wiring loom in the engine bay to the existing earth screw.

**15** Fill and bleed the hydraulic system, as described in Section 2, and check the operation of both the brake warning light and the low fluid level warning light.

#### 14 Tandem master cylinder (type 1) - removal, overhaul and refitting



**Note:** Before starting work, refer to the warning at the beginning of Section 2 concerning the dangers of hydraulic fluid.

#### Removal

**1** Place a cloth around the master cylinder to catch any spilled fluid then unscrew the hydraulic pipe unions from the master cylinder

and carefully pull the pipes clear. Plug or tape over the disconnected unions to prevent dirt entry.

**2** Undo and remove the two nuts and spring washers securing the master cylinder to the bulkhead. Lift off the master cylinder, leaving the pushrod attached to the brake pedal.

#### Overhaul

**3** Remove the filler cap from the master cylinder, then drain and discard the hydraulic fluid from the reservoir.

**4** Mount the master cylinder in a vice with protected jaws, so that the mouth of the cylinder bore is uppermost.

**5** Slide off the rubber boot, compress the

return spring and, using a small screwdriver, remove the Spirolex ring from its groove in the primary piston (see illustration). Take care not to distort the coils of the ring or score the bore of the cylinder.

**6** Using a pair of circlip pliers, remove the piston retaining circlip.

**7** Carefully move the piston up and down in the bore so as to free the nylon guide bearing and cap seal. Lift away the guide bearing seal.

**8** Lift away the plain washer.

**9** Using a pair of circlip pliers, remove the inner circlip.

**10** The primary and secondary piston assembly, complete with the stop washer, may now be withdrawn from the cylinder bore.

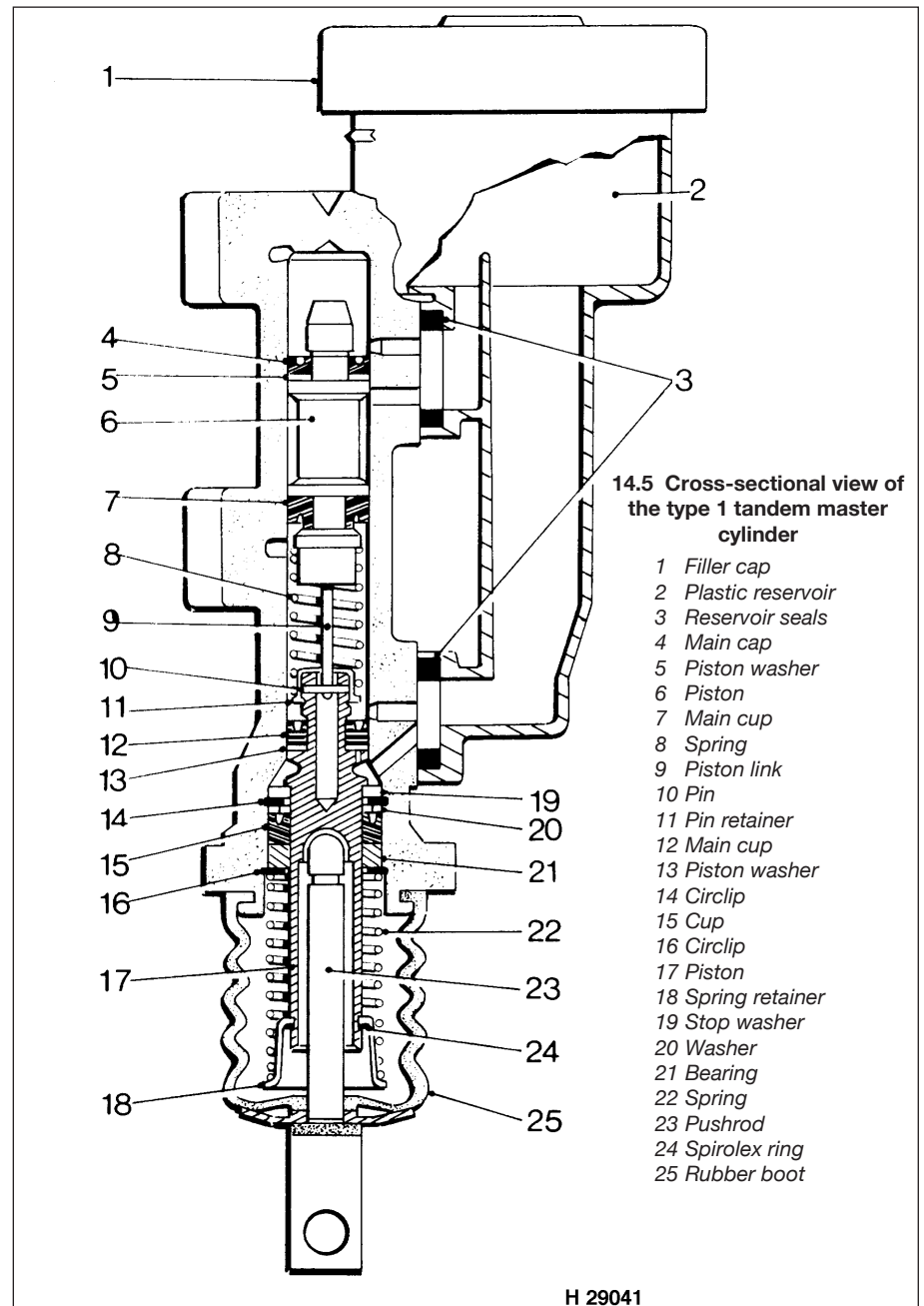

**14.5 Cross-sectional view of the type 1 tandem master cylinder**

- 1 Filler cap
- 2 Plastic reservoir
- 3 Reservoir seals
- 4 Main cup
- 5 Piston washer
- 6 Piston
- 7 Main cup
- 8 Spring
- 9 Piston link
- 10 Pin
- 11 Pin retainer
- 12 Main cup
- 13 Piston washer
- 14 Circlip
- 15 Cup
- 16 Circlip
- 17 Piston
- 18 Spring retainer
- 19 Stop washer
- 20 Washer
- 21 Bearing
- 22 Spring
- 23 Pushrod
- 24 Spirolex ring
- 25 Rubber boot

H 29041

## 9•14 Braking system

- 11 Lift away the stop washer.
- 12 Compress the spring that separates the two pistons then, using a small diameter parallel pin punch, drive out the roll pin that retains the piston link.
- 13 Inspect and note the location of the rubber cups (look for the moulded indentations) then remove the cups and washers from the pistons.
- 14 Undo and remove the four bolts that secure the plastic reservoir to the body and lift away the reservoir.
- 15 Recover the two reservoir sealing rings.
- 16 Unscrew and remove the hydraulic pipe connection adapters, discard the copper gaskets and recover the spring and trap valves.
- 17 Wash all parts in clean hydraulic fluid or methylated spirit and dry with a lint-free cloth.
- 18 Examine the bore of the cylinder carefully for any signs of scores or ridges. If this is found to be smooth all over, new seals can be fitted. If, however, there is any doubt of the condition of the bore, then a new cylinder must be obtained and fitted. *Never re-use old seals* as they will have deteriorated with age even though this may not be evident during visual inspection.
- 19 Reassembly of the master cylinder is the reverse sequence to removal, but the

following additional points should be noted:

- a) *All components should be assembled wet by dipping in clean brake fluid.*
- b) *Locate the piston washer over the head of the secondary piston, convex surface first, then carefully ease the secondary cup over the piston and seat it with its flat surface against the washer.*
- c) *Fit new copper gaskets to the connection adapters.*

### Refitting

20 Refitting is the reverse sequence to removal. On completion, bleed the complete hydraulic system as described in Section 2.

### 15 Tandem master cylinder (type 2) - removal, overhaul and refitting



**Note:** Before starting work, refer to the warning at the beginning of Section 2 concerning the dangers of hydraulic fluid.

### Removal

1 From inside the car, release the heater air inlet ducting from the side of the heater unit and wheel arch. Remove the ducting from under the parcel shelf.

2 Extract the split pin and withdraw the clevis pin securing the master cylinder pushrod to the brake pedal.

3 Working in the engine compartment, disconnect the wiring connector from the brake failure warning switch on the master cylinder body.

4 Place a cloth around the master cylinder to catch any spilled fluid then unscrew the hydraulic pipe unions from the side of the master cylinder body and carefully pull the pipes clear. Plug or tape over the disconnected unions to prevent dirt entry.

5 Unscrew the two nuts securing the master cylinder to the bulkhead and lift the unit off.

### Overhaul

6 Remove the filler cap from the master cylinder, and drain and discard the hydraulic fluid from the reservoir.

7 Mount the cylinder in a vice with protected jaws, so that the reservoir is uppermost.

8 Unscrew the two reservoir retaining screws and lift the reservoir off the master cylinder body (see illustration). Carefully withdraw the two reservoir sealing washers from the outlets.

9 Push in the pushrod as far as possible, and using pliers, extract the secondary piston stop pin from its recess.

#### 15.8 Exploded view of the type 2 tandem master cylinder

- 1 Reservoir and retaining screw
- 2 Reservoir sealing washers
- 3 Master cylinder body
- 4 End plug assembly
- 5 Pressure differential piston (inset shows alternative assembly)
- 6 Primary piston and spring (inset shows alternative assembly)
- 7 Piston rubber seals
- 8 Secondary piston and spring
- 9 Secondary piston seals
- 10 Primary piston seals
- 11 Dust cover
- 12 Circlip
- 13 Stop pin
- 14 Secondary piston seals

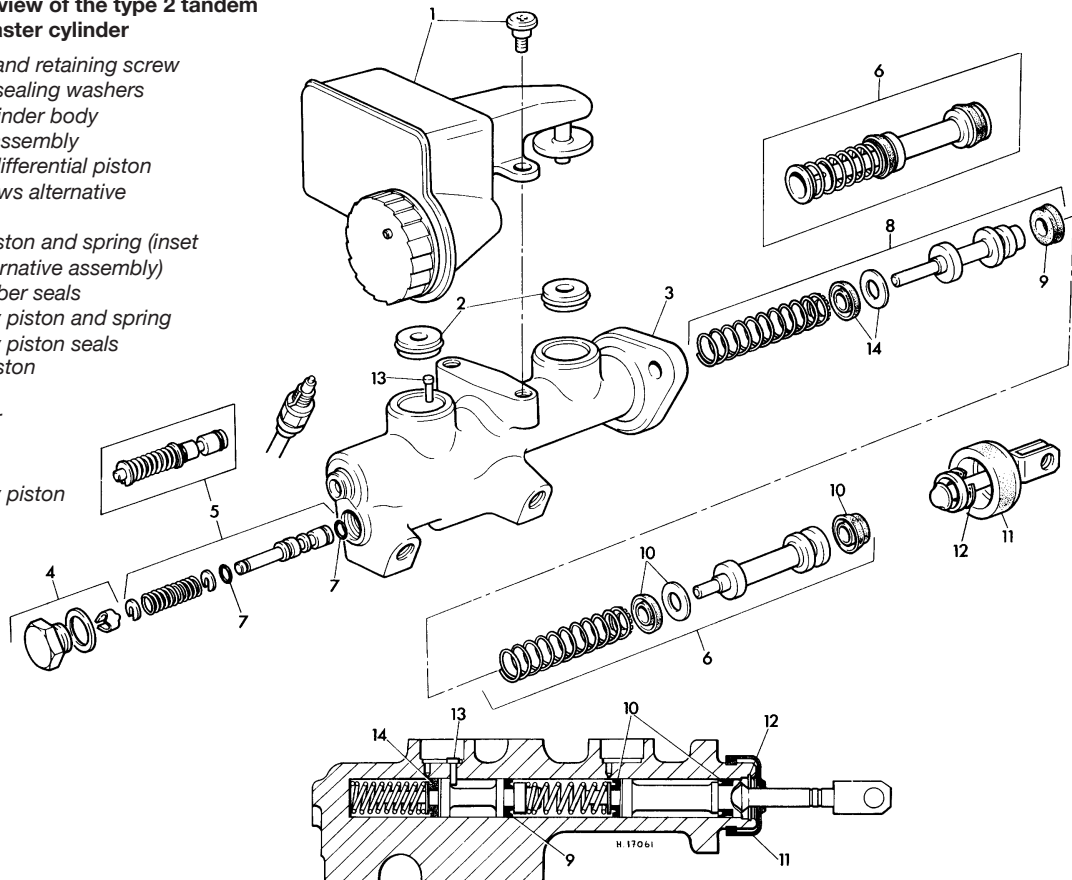

**10** Release the pushrod rubber boot from the end of the cylinder, push the pushrod in and extract the retaining circlip. Now lift away the pushrod assembly.

**11** Remove the master cylinder from the vice, tap it on a block of wood and withdraw the primary and secondary piston assemblies from the cylinder bore.

**12** Unscrew the brake failure switch from the cylinder body.

**13** Unscrew the end plug and washer, then remove the distance piece and pressure differential piston assembly.

**14** Note the position and direction of fitting of the rubber seals on the piston assemblies, and then carefully remove them.

**15** Wash all the parts in clean hydraulic fluid or methylated spirit and dry with a lint-free cloth.

**16** Examine the bore of the master cylinder carefully for any signs of scores or ridges. If this is found to be smooth all over, new seals can be fitted. If, however, there is any doubt

about the condition of the bore, then a new cylinder must be obtained and fitted. *Never re-use old seals*, as they will have deteriorated with age even though this may not be evident during visual inspection.

**17** Reassembly of the master cylinder is the reverse sequence to removal, but the following additional points should be noted:

- Thoroughly lubricate all components in clean hydraulic fluid and assemble them wet
- Refit the seals onto the pistons using fingers only, and ensure that they are fitted the correct way round
- When refitting the secondary piston assembly, push the piston down the bore using a soft metal rod and insert the stop pin. The primary piston and remaining components can then be fitted

### Refitting

**18** Refitting is the reverse sequence to removal. On completion, bleed the complete hydraulic system as described in Section 2.

## 16 Tandem master cylinder (type 3) - removal, overhaul and refitting



Removal, refitting and overhaul of the type 3 master cylinder is essentially the same as for the type 2 unit and reference should be made to the procedures contained in Section 15. Bear in mind also the differences between the two types outlined in Section 13.

## 17 Tandem master cylinder (type 4) - removal, overhaul and refitting



**Note:** Before starting work, refer to the warning at the beginning of Section 2 concerning the dangers of hydraulic fluid.

### Removal

**1** If necessary, for improved access to the front and rear bleed screws, jack up the front and rear of the car and support it on axle stands (see "Jacking and vehicle support").

**2** Connect a bleed tube to both the front caliper and rear wheel cylinder bleed screws on the right-hand side, and place the ends of the tubes in suitable containers.

**3** Open both bleed screws and depress the brake pedal until the master cylinder is completely empty, then tighten the screws.

**4** Disconnect the low fluid level warning light wiring from the fluid reservoir filler cap.

**5** Place a cloth around the master cylinder to catch any spilled fluid then unscrew the hydraulic pipe unions from the master cylinder and carefully pull the pipes clear. Plug or tape over the disconnected unions to prevent dirt entry.

**6** Unscrew the mounting nuts securing the master cylinder to the vacuum servo unit, then withdraw it from the engine compartment, taking care not to spill any brake fluid on the bodywork.

**7** Remove the O-ring from the recess in the master cylinder.

### Overhaul

**8** Remove the filler cap from the master cylinder, and drain and discard the hydraulic fluid from the reservoir.

**9** Mount the cylinder in a vice with protected jaws, so that the reservoir is uppermost.

**10** Tap out the retaining roll pin and lift the reservoir off the master cylinder body (see illustration). Carefully withdraw the two reservoir sealing washers from the outlets followed by the metal seating washers.

**11** Push in the primary piston and, using pliers, extract the secondary piston stop pin from its recess.

**12** Extract the retaining circlip from the end of the master cylinder bore.

**13** Remove the master cylinder from the vice, tap it on a block of wood and withdraw the primary and secondary piston assemblies from the cylinder bore.

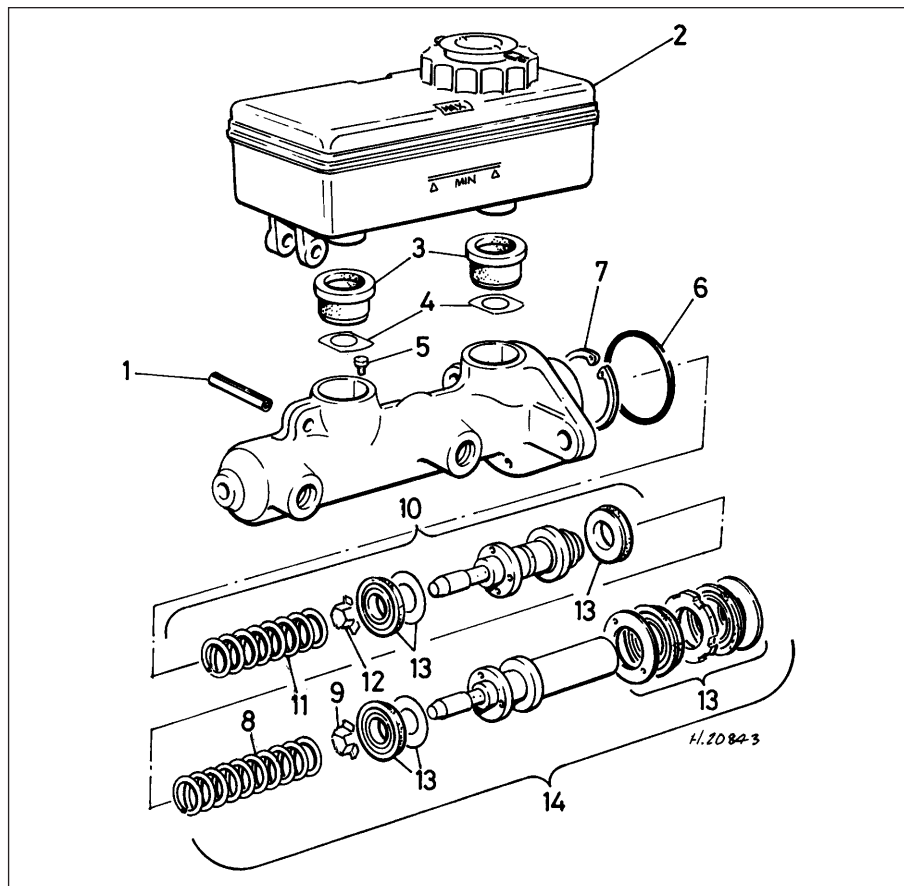

17.10 Exploded view of the type 4 tandem master cylinder

- |                             |                                |
|-----------------------------|--------------------------------|
| 1 Roll pin                  | 8 Primary spring               |
| 2 Brake fluid reservoir     | 9 Spring retainer              |
| 3 Sealing washers           | 10 Secondary piston components |
| 4 Metal seating washers     | 11 Secondary spring            |
| 5 Secondary piston stop-pin | 12 Spring retainer             |
| 6 O-ring                    | 13 Seal and washer             |
| 7 Circlip                   | 14 Primary piston components   |

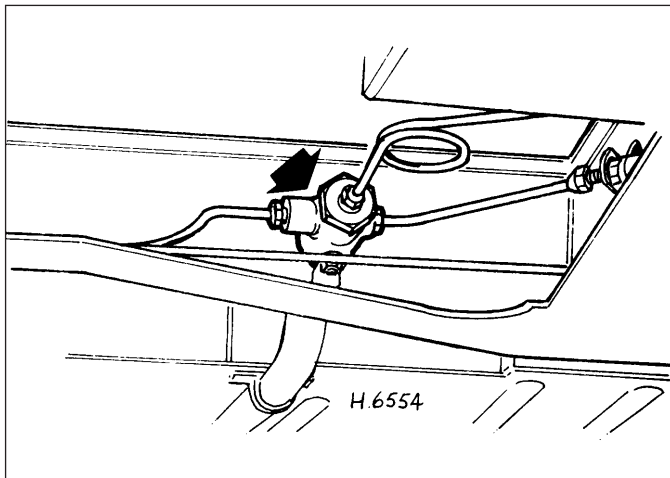

18.3 Location of pressure regulating valve on rear subframe

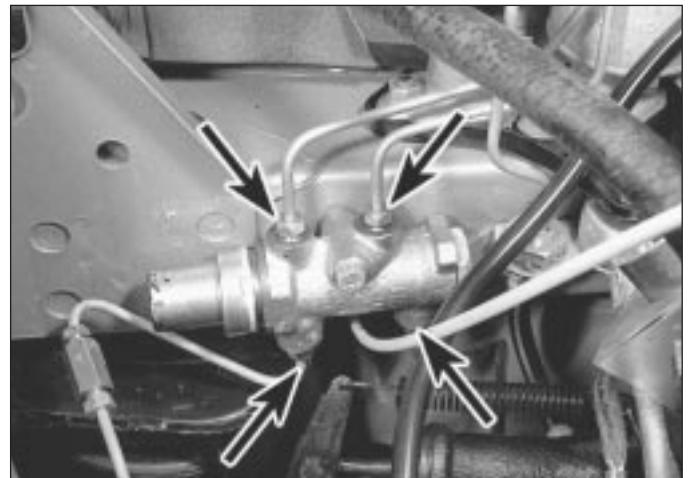

19.2 Pressure reducing valve hydraulic pipe unions

14 Note the position and direction of fitting of the rubber seals on the piston assemblies, then carefully remove them.

15 Wash all the parts in clean hydraulic fluid or methylated spirit and dry with a lint-free cloth.

16 Examine the bore of the master cylinder carefully for any signs of scores or ridges. If this is found to be smooth all over, new seals can be fitted. If, however, there is any doubt about the condition of the bore, then a new cylinder must be obtained and fitted. *Never re-use old seals*, as they will have deteriorated with age even though this may not be evident during visual inspection.

17 Reassembly of the master cylinder is the reverse sequence to removal, but the following additional points should be noted:

- a) Thoroughly lubricate all components in clean hydraulic fluid and assemble them wet.
- b) Refit the seals onto the pistons using fingers only, and ensure that they are fitted the correct way round.
- c) When refitting the secondary piston assembly, push the piston down the bore using a soft metal rod and insert the stop pin. The primary piston and remaining components can then be fitted.

### Refitting

18 Refitting is the reverse sequence to removal, but note the following additional points:

- a) Smear the O-ring with clean brake fluid before fitting it in the recess.
- b) On completion, bleed the hydraulic system as described in Section 2.
- c) Check that the low fluid warning system is functioning correctly.

### 18 Pressure regulating valve (single circuit system) - removal, overhaul and refitting



**Note:** All models with single circuit braking systems incorporate a pressure regulating valve in the rear brake hydraulic circuit. The valve regulates the hydraulic pressure available at the rear wheels, and therefore prevents the rear brakes from locking due to forward weight transfer under heavy braking. Before starting work, refer to the warning at the beginning of Section 2 concerning the dangers of hydraulic fluid.

#### Removal

- 1 Chock the front wheels then jack up the rear of the car and support it on axle stands (see "Jacking and vehicle support"). Remove the rear roadwheels.
- 2 Remove the brake master cylinder filler cap, top-up the reservoir, place a thin piece of polythene over the filler neck and refit the cap. This will reduce hydraulic fluid loss when the rear brake pipes are removed from the regulating valve.
- 3 Thoroughly clean the exterior of the valve, located on the rear subframe, ensuring that all dirt and grit is removed from the area around the brake pipe unions (see illustration).
- 4 Undo and remove the three hydraulic unions and lift the brake pipes out of the valve. Protect the ends of the pipes to prevent possible dirt ingress.
- 5 Undo and remove the retaining nut and bolt and lift the valve off its mounting.

#### Overhaul

- 6 Clamp the valve in a vice and remove the large end plug and sealing washer.
- 7 Lift out the valve assembly and return spring.
- 8 Thoroughly clean the components in clean hydraulic fluid or methylated spirit and dry with a lint-free cloth.

9 Examine the valve, cylinder bore and rubber seals for wear and renew as necessary. Rubber seals are not supplied separately, and if they appear swollen or worn it will be necessary to obtain a new valve assembly complete with seals.

10 Lubricate the components in clean hydraulic fluid and then refit the spring and valve assembly into the valve body. Now refit the end plug and sealing washer.

### Refitting

11 Refitting the valve is the reverse sequence to removal. Bleed the hydraulic system as described in Section 2 on completion. If hydraulic fluid loss has been kept to a minimum it should only be necessary to bleed the rear brakes.

### 19 Pressure reducing valve (dual circuit system) - removal and refitting



**Note:** On certain models fitted with dual circuit braking systems a pressure reducing valve is used to limit the braking force at the rear wheels. The operation of the valve is similar to the pressure regulating valve used on single circuit systems. Before starting work, refer to the warning at the beginning of Section 2 concerning the dangers of hydraulic fluid.

#### Removal

- 1 Remove the brake master cylinder filler cap, top-up the reservoir, and place a thin piece of polythene over the filler neck. Secure the polythene with an elastic band or by refitting the cap. This will reduce hydraulic fluid loss when the brake pipes are disconnected from the valve.
- 2 Unscrew the four pipe unions from the reducing valve and carefully lift out the pipes. Protect the disconnected unions to prevent possible dirt ingress (see illustration).



3 Undo and remove the retaining bolt and lift off the valve.

4 The pressure reducing valve is a sealed unit and cannot be dismantled. If the valve is faulty it must be renewed as a complete assembly.

### Refitting

5 Refitting is the reverse sequence to removal. Bleed the hydraulic system as described in Section 2 on completion.

## 20 Pressure differential warning actuator (dual circuit system) - removal, overhaul and refitting



**Note:** On early type dual circuit braking systems, a separate pressure differential warning actuator, located on the engine compartment bulkhead, informs the driver of failure of one of the braking hydraulic circuits. On later systems so equipped, the warning actuator is incorporated in the master cylinder. Before starting work, refer to the warning at the beginning of Section 2 concerning the dangers of hydraulic fluid.

### Removal

1 Unscrew the brake master cylinder filler cap, place a piece of polythene over the filler neck and refit the cap. This will reduce hydraulic fluid loss when the brake pipes are disconnected.

2 Detach the electrical connector from the switch on the side of the warning actuator body.

3 Unscrew the hydraulic pipe unions and

carefully remove the pipes. Protect the disconnected unions from possible dirt ingress.

4 Undo and remove the retaining bolt and lift off the unit.

### Overhaul

5 Clean off the exterior of the unit and make sure it is free from dirt and grit.

6 Undo and remove the end plug and discard the copper washer (see illustration).

7 Unscrew the warning light switch.

8 Tap the warning actuator body on a block of wood to release the shuttle valve piston assembly and withdraw it from the bore.

9 Remove the two rubber seals from the piston.

10 Wash the components in clean hydraulic fluid or methylated spirit and dry with a lint-free cloth.

11 Carefully inspect the piston and the casing bore for scoring and damage. If the bore and piston are not in perfect condition, renew the complete pressure differential warning actuator. If the components are in a satisfactory condition obtain new seals and a new copper sealing washer. Do not re-use the old seals.

12 Reassembly of the unit is the reverse of the dismantling sequence. Lubricate all the parts with clean hydraulic fluid and assemble them wet. Observe the specified torque wrench settings when refitting the end plug and warning light switch.

### Refitting

13 Refitting is the reverse sequence to

removal. Bleed the hydraulic system as described in Section 2 after refitting.

14 After bleeding the braking system, switch on the ignition and observe the brake failure warning light. If the light is illuminated, press the brake pedal hard: the light should go out and stay out when the pedal is released. If the light fails to go out, the pressure in the braking system is unbalanced or there is a fault in the warning actuator or its switch. Bleed the braking system again, and if this fails to cure the trouble, investigate the warning actuator and the switch.

15 If the brake failure warning light is not illuminated when the brake pedal is depressed, but does come on when the test-push on the switch is operated, then the system is functioning satisfactorily.

## 21 Vacuum servo unit - removal and refitting



### Pre-1989 models

#### Removal

1 Unscrew the brake master cylinder filler cap, place a piece of polythene over the filler neck and refit the cap. This will minimise hydraulic fluid loss when the servo is removed.

2 From under the right-hand front wing detach the inlet ducting from the inlet unit and then withdraw the inlet unit from inside the engine compartment.

3 Disconnect the vacuum pipe from the one-way valve on the servo unit.

4 Remove the securing bracket from the end of the servo unit.

5 Unscrew the hydraulic pipe unions and carefully withdraw them from the servo. Protect the disconnected unions against possible dirt ingress.

6 Undo and remove the nuts securing the servo to its mounting bracket and lift away the unit.

#### Refitting

7 Refitting is the reverse sequence to removal. Bleed the hydraulic system as described in Section 2 on completion.

### 1989 models onward

#### Removal

8 Disconnect the low brake fluid level warning light wiring from the master cylinder fluid reservoir filler cap.

9 Unscrew the master cylinder mounting nuts from the servo unit.

10 Position a container beneath the master cylinder, then loosen (but do not remove) the hydraulic pipe union nuts, to prevent damage to the pipes when the master cylinder is moved from the servo unit. Move the master cylinder clear of the servo unit, then retighten the union nuts.

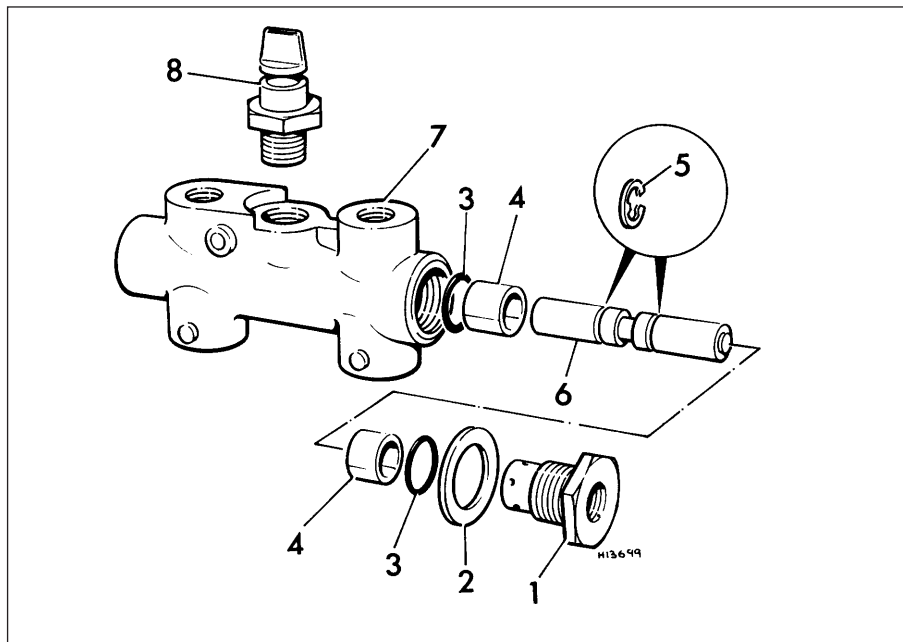

20.6 Exploded view of the pressure differential warning actuator

- |                 |           |          |
|-----------------|-----------|----------|
| 1 End adapter   | 4 Sleeve  | 7 Body   |
| 2 Copper washer | 5 Circlip | 8 Switch |
| 3 O-ring        | 6 Piston  |          |

## 9•18 Braking system

**11** Disconnect the vacuum hose from the servo unit, and release it from the clip.

**12** Extract the split pin, and withdraw the clevis pin securing the pushrod to the brake pedal.

**13** Disconnect the anti-run-on valve hoses, and plug them.

**14** Unscrew the bolt securing the anti-run-on valve to the servo mounting bracket.

**15** Unscrew the mounting nuts and bolts, and withdraw the servo unit and bracket assembly from the engine compartment.

**16** Separate the servo unit from the bracket by disconnecting the clevis and unscrewing the nuts. Prise the O-ring from the recess in the master cylinder.

**17** Refitting is the reverse sequence to removal. Smear the O-ring with clean brake hydraulic fluid and bleed the hydraulic system as described in Section 2 on completion.

### 22 Vacuum servo unit air filter (1989 models onward) - renewal



**1** Working in the engine compartment, prise back the rubber boot from the rear of the servo, and slide it along the push rod (**see illustration**).

**2** Prise the air filter from inside the servo body.

**3** Cut the new air filter in one place with a sharp knife, then locate it over the pushrod and push it into the servo body.

**4** Refit the rubber boot.

### 23 Brake pedal - removal and refitting



The brake pedal is removed together with the clutch pedal, and full information on the removal and refitting procedure will be found in Chapter 6.

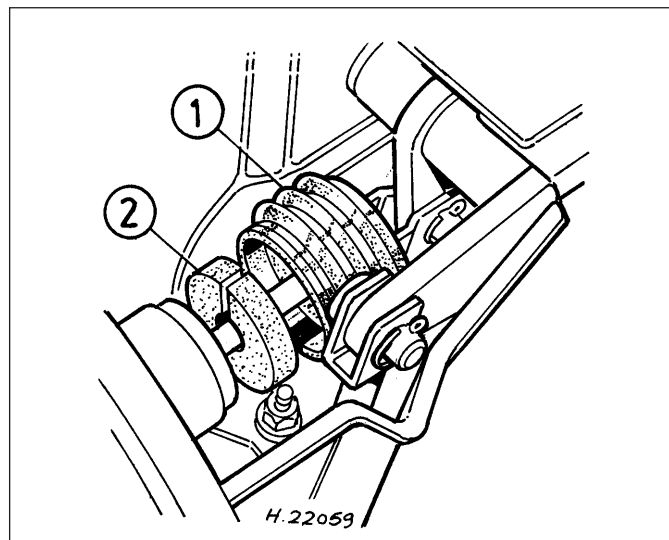

22.1 Vacuum servo unit air filter

1 Rubber boot

2 Air filter





# Chapter 10

## Suspension and steering

### Contents

Front hub bearings - renewal	4	Rear helper spring (models with Hydrolastic suspension) - removal and refitting	18
Front lower suspension arm - removal and refitting	6	Rear hub bearings - renewal	14
Front shock absorber (models with rubber cone suspension) - removal and refitting	11	Rear Hydrolastic displacer unit - removal and refitting	16
Front subframe - removal and refitting	13	Rear radius arm - removal and refitting	19
Front subframe mountings - renewal	12	Rear rubber cone spring - removal and refitting	15
Front suspension Hydrolastic displacer unit - removal and refitting	10	Rear shock absorber (models with rubber cone suspension) - removal and refitting	17
Front suspension rubber cone spring - removal and refitting	9	Rear subframe - removal and refitting	21
Front suspension tie-bar - removal and refitting	7	Rear subframe mountings - renewal	20
Front swivel hub - removal and refitting	3	Steering and suspension check	See Chapter 1
Front swivel hub balljoints - removal and refitting	5	Steering and suspension lubrication	See Chapter 1
Front upper suspension arm - removal and refitting	8	Steering column - dismantling and reassembly	24
General information	1	Steering column - removal and refitting	23
Hydrolastic suspension system - principles of operation	2	Steering rack rubber gaiter - removal and refitting	26
Rack-and-pinion steering gear - dismantling, inspection and reassembly	28	Steering tie-rod outer balljoint - removal and refitting	25
Rack-and-pinion steering gear - lubrication	29	Steering wheel - removal and refitting	22
Rack-and-pinion steering gear - removal and refitting	27	Tyre condition and pressure checks	See "Weekly Checks"
		Wheel alignment and steering angles - general information	30

### Degrees of difficulty

<b>Easy</b> , suitable for novice with little experience 	<b>Fairly easy</b> , suitable for beginner with some experience 	<b>Fairly difficult</b> , suitable for competent DIY mechanic 	<b>Difficult</b> , suitable for experienced DIY mechanic 	<b>Very difficult</b> , suitable for expert DIY or professional 
---	--	--	---	--

### Specifications

#### Front suspension

Type:	
Rubber cone suspension	Independent by rubber cone springs and unequal length upper and lower suspension arms
Hydrolastic suspension	Independent by interconnected Hydrolastic displacers and unequal length upper and lower suspension arms

#### Rear suspension

Type:	
Rubber cone suspension	Independent by rubber cone springs and trailing radius arms
Hydrolastic suspension	Independent by interconnected Hydrolastic displacers, trailing radius arms and coil hold-down springs

#### Steering

Type	Rack-and-pinion
Turns lock-to-lock	2.7
Tie-rod balljoints centre-to-centre setting dimension	1053.0 mm
Lubricant capacity (see text):	
Early models	0.2 litre
Later models	0.1 litre
Lubricant type (see text):	
Early models	Gear oil, viscosity SAE 90EP
Later models	Semi fluid grease

## 10•2 Suspension and steering

### Wheel alignment and steering angles

Front wheel:	
Toe setting	1.58 mm toe-out
Castor angle	3° ± 1° positive
Camber angle	2° ± 1° positive
Swivel hub inclination	9° 30'
Trim height (models with Hydrolastic suspension)	343.0 mm ± 9.5 mm
Rear wheel:	
Toe setting	3.17 mm toe-in
Camber angle	0.5° to 2.5° positive

### Roadwheels

Wheel size:	
Steel wheels:	
Standard wheels	3.5B x 10, 4.5J x 10 or 4.5J x 12 according to model
"Denovo" wheels	80.0 x 310.0 mm
Alloy wheels	5J x 10 or 4.5J x 12 according to model

### Tyres

Tyre size	5.20 x 10, 145SR x 10, 145/70SR x 12, 165/70HR x 10 or 155/65SF x 310 ("Denovo") according to model
Tyre pressures	See " <i>Weekly Checks</i> "

### Torque wrench settings

	Nm	lbf ft
<b>Front suspension</b>		
Driveshaft retaining nut:		
Drum brake models	83	60
Disc brake models:		
With multiple split pin holes in driveshaft	207	150
With single split pin hole in driveshaft	255 to 270	188 to 200
Swivel hub balljoint domed nut	102	75
Swivel hub balljoint to suspension arm	54	40
Tie-rod to subframe	30	22
Tie-rod to suspension arm	26	19
Upper suspension arm pivot shaft nut	72	53
Lower suspension arm pivot bolt nut	45	33
<b>Rear suspension</b>		
Rear hub retaining nut	81	60
Radius arm pivot shaft nut	72	53
<b>Steering</b>		
Steering column lower clamp pinch-bolt	16	12
Steering column upper clamp	19	14
Steering rack U-bolts	15	11
Tie-rod balljoint nut	30	22
Steering wheel nut	47	35
Steering rack tie-rod ball housing collar	52	38
<b>Roadwheels</b>		
Roadwheel nuts	63	45

## 1 General information

The front and rear suspension assemblies and associated components are mounted on subframes which are bolted to the underside of the bodyshell. The subframes are of welded all-steel construction, the front subframe also providing mounting points for the engine/transmission assembly.

The front suspension on all Mini models is of the independent type, each side consisting of an upper and lower suspension arm. The lower arm is supported in rubber bushes at its inner end, while the inner end of the upper

arm pivots on two caged needle roller bearings. The outer ends of the two suspension arms are bolted to the tapered shanks of the swivel hub balljoints. Fore-and-aft movement of each front suspension assembly is controlled by a tie-bar bolted at one end to the lower suspension arm and mounted at the other end, via rubber bushes, to the subframe. The swivel hubs contain tapered roller or ball bearings which support the outer ends of the driveshafts, and also provide mounting points for the drum brake backplate or disc brake calipers. Suspension and steering movement of the swivel hubs is catered for by adjustable balljoints.

The rear suspension on all models is also independent by means of two trailing radius

arms. The forward end of each radius arm contains a needle roller bearing and bronze bush, which allows the arm to pivot on a shaft bolted to the subframe. The brake backplate is bolted to the rear end of each radius arm, as is the stub axle which carries the rear wheel hub and bearings.

While all Mini models share the same suspension component layout, two different types of springing and damping have been employed. All models are now equipped with dry suspension, whereby a rubber cone spring and telescopic shock absorber are fitted to the suspension assembly at each wheel. Early Clubman and 1275GT models were equipped with Hydrolastic suspension, whereby a displacer unit which combines the



actions of both spring and shock absorber is fitted to each suspension assembly, in place of the rubber cone. The displacer units are interconnected front-to-rear on each side of the vehicle and are filled with a water-based, non-corrosive fluid under pressure. The principles of operation of the hydrolastic suspension system are described in detail in Section 2.

The steering gear is of the conventional rack-and-pinion type with tie-rods connected to the swivel hub steering arms by tie-rod outer balljoints. Further balljoints on the inner ends of the tie-rods are screwed into the rack. The upper splined end of the helically toothed pinion protrudes from the rack housing and engages with the splined end of the steering column. The pinion spline is grooved and the steering column is held to the pinion by a clamp bolt which partially rests in the pinion groove.

## 2 Hydrolastic suspension system - principles of operation

### Component layout

The Hydrolastic suspension system consists of a Hydrolastic unit (known as a displacer) fitted to the suspension assembly at each wheel, and two metal pipes which interconnect the displacer units on each side of the vehicle, front to rear. The system is filled with a water-based, non-corrosive antifreeze fluid under pressure.

Each displacer consists of a rubber spring fitted to the upper part of the unit. This rubber spring is the actual springing and damping medium, and is shaped in such a way as to give a progressive rate characteristic similar to the rubber cone spring fitted to non-Hydrolastic Minis. At the lower end of the displacer unit a tapered piston, attached to a diaphragm operates within a tapered cylinder. The diaphragm seals off the lower part of the displacer and the piston is coupled to the suspension assembly. Internally the displacer unit is divided into an upper and lower chamber by a separator plate, which also contains the damper valves and a bleed hole.

### Operation

Movement of the vehicle suspension actuates the displacer piston, causing fluid to be displaced through the separator plate and into the upper chamber either via the bleed hole, if suspension movement is small, or through the damper valve if the movement is more vigorous. This causes the upper chamber to deflect upwards against the resistance of the rubber spring, thus damping the suspension movement. In addition to this, fluid in the upper chamber will be displaced via the transfer pipe to the displacer unit connected to the other suspension assembly, on the same side of the car. This will cause

the piston in this displacer to move downwards and act on the suspension, ensuring that the vehicle remains in a level attitude. In the event of both suspension assemblies on the same side of the car deflecting together (ie body roll when cornering), no fluid movement between the two displacers will occur and the entire fluid pressure will be applied simultaneously to both displacer pistons giving a very high resistance to the rolling movement.

As the relative front end weight of the Mini is high, the normal ride attitude of the car would be tail high, as the partially deflected front suspension would transfer fluid to the rear suspension, causing it to rise. To overcome this, non-adjustable coil hold-down springs are fitted between the chassis and each rear suspension arm. Thus, fluid is transferred from rear to front and a near level attitude is maintained.

### Servicing

The Hydrolastic system is completely sealed, and therefore virtually maintenance free. It is advisable, however, at periodic intervals, to inspect the external condition of the displacer units, hoses and pipe unions. Any seepage of fluid from the union between displacer hose and transfer pipe, or from any other part of the system, will cause the vehicle suspension to sag on the affected side.

It will be necessary when working on certain suspension components to remove or disconnect the displacer units or transfer pipes. Before doing this, the system must be depressurised by a Rover dealer who will have the equipment required to remove the fluid and evacuate the system. The vehicle can be

driven for short distances at slow speeds (ie below 30 mph/48 kph) in a depressurised condition, providing it is driven carefully. On completion of the work the system must be repressurised, again by a dealer.

The pressure in the system determines the trim height of the vehicle and this should also be checked periodically to ensure that it has not altered appreciably. The trim height is measured from the centre of the front wheel hub to the top of the wheel arch. It is important to ensure that the correct height is maintained otherwise the steering geometry may be affected, resulting in uneven tyre wear and insensitive handling.

## 3 Front swivel hub - removal and refitting



### Removal

**1** Working under the wheel arch, undo and remove the single retaining screw and lift out the upper suspension arm rebound rubber. Position a solid packing piece of approximately the same thickness in its place (see illustration).

**2** Chock the rear wheels then jack up the front of the car and support it on axle stands (see "Jacking and vehicle support"). Remove the front roadwheel.

**3** Extract the split pin from the driveshaft retaining nut and, with an assistant firmly depressing the brake pedal, undo and remove the driveshaft nut using a socket and extension bar. Remove the washer or split-collar, as applicable, located behind the

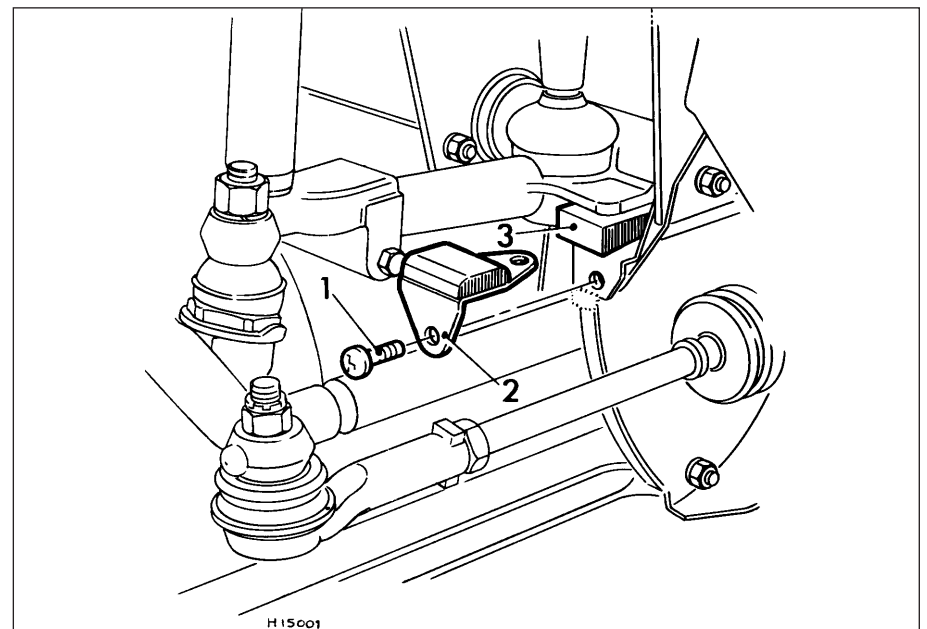

**3.1 Fitting a solid packing wedge in place of the suspension rebound rubber**

1 Screw

2 Rebound rubber

3 Packing piece



**3.5 Remove the steering tie-rod balljoint with a universal separator**

driveshaft nut. Note that on disc brake models, the driveshaft retaining nut is extremely tight and it may be beneficial to fabricate a home-made tool to prevent the hub rotating when undoing the nut (see Chapter 8, Section 2).

**4** On disc brake models, undo and remove the brake caliper retaining bolts. Lift off the caliper complete with brake pads, and tie it out of the way from a convenient place under the wheel arch. On models fitted with drum brakes, clamp the flexible brake hose with a proprietary brake hose clamp or a self-gripping wrench with its jaws suitably protected. Now slacken the brake hose union, at the wheel cylinder by half a turn.

**5** Undo and remove the steering tie-rod balljoint retaining locknut and then release the balljoint tapered shank from the steering arm using a universal balljoint separator (**see illustration**).

**6** Undo and remove the nuts and spring washers securing the swivel hub balljoints to the upper and lower suspension arms (**see illustration**).

**7** Using the method described in paragraph 5, separate the upper and lower suspension arms from the tapered shanks of the balljoints.

**8** Carefully lift the swivel hub assembly off the two suspension arms. At the same time, tap the centre of the driveshaft, using a soft-faced mallet, until the driveshaft can be withdrawn from the rear of the swivel hub assembly.

**9** On disc brake models, withdraw the swivel hub assembly and then lift off the driving flange and disc. On models with drum brakes, support the flexible brake hose to avoid stretching it and then rotate the complete swivel hub assembly anti-clockwise to unscrew it from the hose (**see illustration**). The hub can now be lifted away and the end of the brake hose protected to prevent dirt ingress. Collect the copper sealing washer from the end of the hose as the hose is removed. Note that a new washer will be required for refitting.

**Refitting**

**Models with drum brakes**

**10** Refitting is the reverse sequence to removal, bearing in mind the following points:

- a) Ensure that the hub bearing water shield is in place on the driveshaft CV joint and

**TOOL TIP**



*An alternative method of releasing the balljoint tapered shank is to refit the locknut to the balljoint and screw it on two or three turns. Using a medium hammer, sharply strike the end of the steering arm until the shock separates the taper. Now remove the locknut and lift the joint off the arm.*

*positioned approximately 6 mm from the shoulder of the joint.*

- b) Use a new copper washer on the flexible brake hose and ensure that the hose is not twisted when refitting the swivel hub. Bleed the hydraulic system at the appropriate wheel on completion (see Chapter 9).
- c) Tighten all nuts and bolts to the specified torque.
- d) Tighten the driveshaft retaining nut to the specified torque, then tighten the nut further to align the split pin holes in the driveshaft and nut. Secure the nut with a new split pin.

**Models with disc brakes**

**11** Refitting is the reverse sequence to removal, bearing in mind points a and c detailed in paragraph 10. Additionally, the following procedure must be observed, otherwise it is possible that the split-collar fitted beneath the driveshaft retaining nut will become clamped to the shaft before the shaft is fully home in the hub bearings.

**12** Insert the driveshaft through the swivel hub, but do not fit the split collar. Obtain a plain washer of the dimensions shown (**see illustration**). If necessary, make the washer from mild steel.



**3.9 Withdraw the swivel hub from the end of the driveshaft**



**3.6 Remove the lower swivel hub balljoint retaining nut**

**13** Fit the plain washer over the driveshaft end. Fit the driveshaft retaining nut and, using the same procedure as for removal to prevent the hub rotating, tighten the nut to the specified torque to seat the shaft in the hub bearings. Note that there are two different torque settings for the driveshaft nut; one for driveshafts with multiple split pin holes, and a higher setting for driveshafts with a single split pin hole. Now remove the nut and washer and smear engine oil over the driveshaft threads.

**14** Examine the split-collar, and renew it if damaged or worn. Fit the collar and driveshaft retaining nut, and once again tighten it to the specified torque. Tighten the nut further to align the split pin holes in the driveshaft and nut, then secure the nut with a new split pin.

**4 Front hub bearings - renewal**



**Drum brake models**

**1** Remove the swivel hub assembly as described in Section 3.

**2** With the assembly on the bench, slacken the brake adjusters, remove the two brake drum retaining screws and lift off the drum. If it is tight, tap it gently using a soft-faced mallet.

**3** Arrange two wooden blocks approximately 250 mm high, on the bench, far enough apart for the drive flange to lie freely between them,

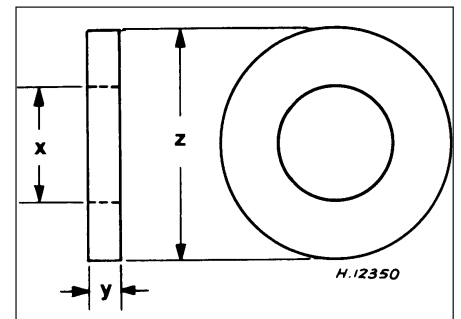

**3.12 Details of special washer required for fitting the driveshaft on disc brake models**

X = 25 mm    Y = 6.5 mm    Z = 50 mm

with the brake shoes resting on the top of the blocks. Using a tube or drift of suitable diameter, tap the drive flange out of the hub. It is likely that the inner race of the outer bearing together with the oil seal and the outer bearing distance piece will come away with the flange (see illustration). If this happens, carefully remove these items from the flange with the aid of a puller.

**4** Undo and remove the four bolts securing the brake backplate to the swivel hub and lift off the backplate with brake shoes still in position.

**5** Clean away any surplus grease from the centre of the hub between the bearings, and

then prise out the two oil seals using a screwdriver. Note that there is a spacer fitted between the rear oil seal and the bearing outer race.

**6** Using a tube or drift of suitable diameter tap out the bearing inner races away from the centre of the hub. Take care not to lose the balls which will be dislodged as the inner races are released, and recover the spacer (if fitted) between the two bearings.

**7** Firmly support the swivel hub in a vice and drift out the two bearing outer races from each side of the hub.

**8** Clean the bearings and swivel hub

thoroughly using paraffin or a suitable solvent and dry with a lint-free rag. Remove any burrs or score marks from the hub bore with a fine file or scraper.

**9** Examine carefully the bearing inner and outer races, the balls and ball cage for pitting, scoring or cracks, and if at all suspect renew the bearings. It will also be necessary to renew the oil seals as they will have been damaged during removal.

**10** If the old bearings are in a satisfactory condition and are to be re-used, reassemble the balls to the ball cage, place it in the outer race and then press the inner race into position.

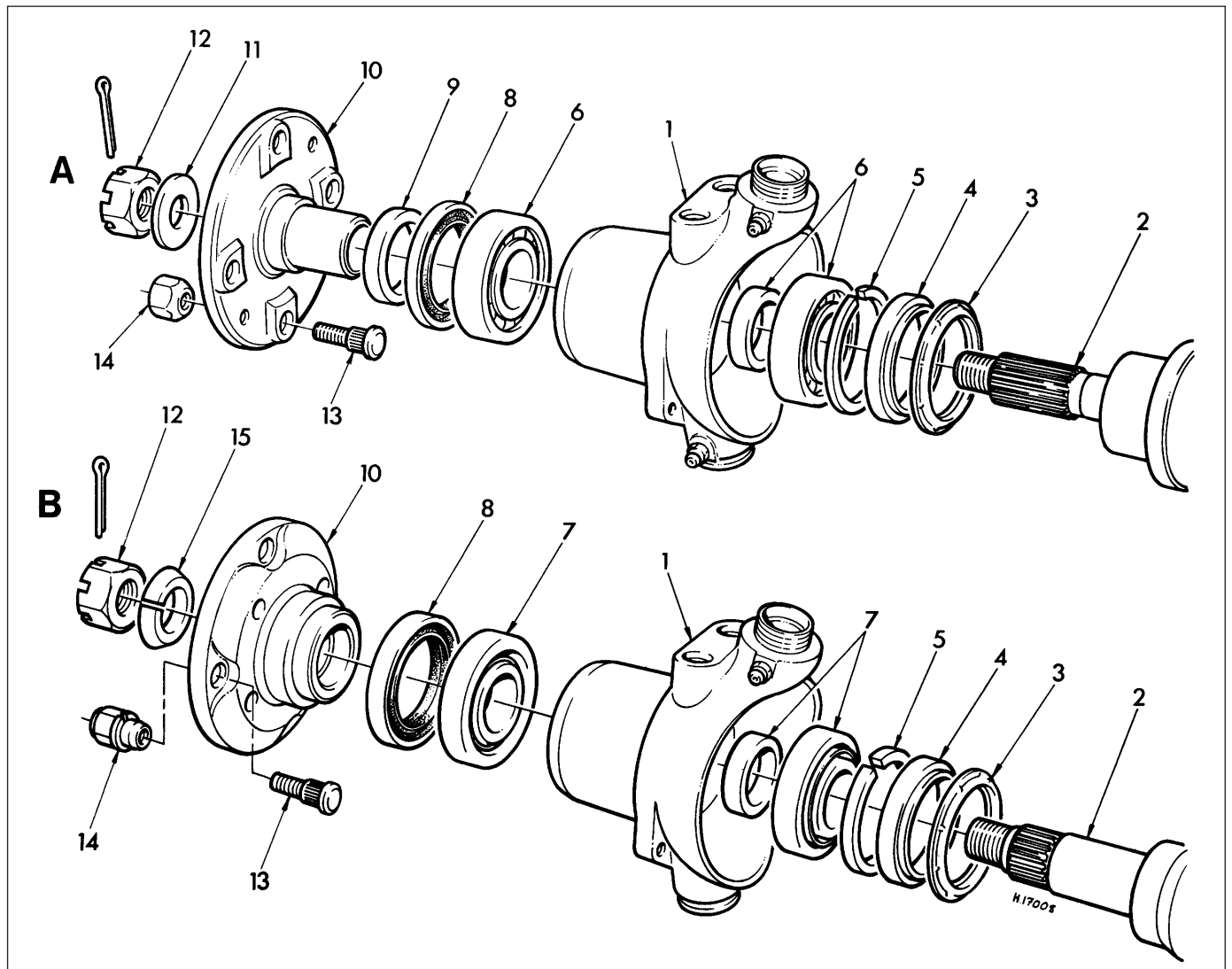

4.3 Exploded view of the front hub components

*A Drum brake models*

- 1 Swivel hub
- 2 Driveshaft
- 3 Water shield
- 4 Inner oil seal
- 5 Oil seal spacer

*B Disc brake models*

- 6 Ball bearing and spacer set
- 7 Taper roller bearing and spacer set
- 8 Outer oil seal
- 9 Distance ring
- 10 Driving flange

- 11 Thrust washer
- 12 Castellated hub nut
- 13 Wheel stud
- 14 Wheel nut
- 15 Thrust washer

**11** Before refitting the bearings to the hub, pack them thoroughly with a high melting-point grease. Do not fill the space between the bearings in the swivel hub with grease.

**12** Place one of the bearings in position on the hub with the word THRUST or the markings stamped on the outer race facing toward the centre of the hub. **Note:** *Certain later models are fitted with bearings having lengthened inner races which butt against each other. On these assemblies the bearing spacer is omitted and the bearings are fitted with the identification markings facing away from the centre of the hub.* Using a tube of suitable diameter or a drift, press the outer race into the hub between the vice jaws or very carefully tap it into position. Ensure that the outer race does not tip slightly and bind as it is being fitted. If this happens, the outer race will crack so take great care to keep it square. Ensure that the bearing seats firmly against the shoulder in the centre of the hub when fitted.

**13** Now place the bearing spacer in position and repeat the previous paragraph for the second bearing. **Note:** *Some makes of bearing have lengthened inner races which butt against each other. In this case the bearing spacer is no longer needed.*

**14** Tap a new oil seal into place over the outer bearing using a block of wood to keep it square. Note that both oil seals are fitted with their sealing lips inwards and that the inner seal has a second lip on its inner circumference.

**15** Refit the split spacer against the inner bearing and tap in the inner oil seal using a tube of suitable diameter.

**16** Refit the brake backplate to the swivel hub and secure with the four retaining bolts, tightened to the specified torque (see Chapter 9).

**17** Place the distance piece over the driving flange with the chamfer towards the flange. With the inner race of the inner bearing suitably supported, tap the driving flange into the bearings. Ensure that the flange enters the distance piece between the two bearings squarely, otherwise the bearing inner race will be dislodged with possible damage to the oil seal.

**18** The brake drum and its retaining screws can now be refitted and the complete swivel hub assembly refitted to the car as described in the Section 3. When refitting the hub assembly, ensure that the water shield on the driveshaft is packed with grease around its sealing face and positioned 6.35 mm from the end of the shaft. Adjust the brakes as described in Chapter 1 before lowering the car to the ground.

### Disc brake models

**19** Remove the swivel hub assembly as described in Section 3.

**20** With the assembly on the bench, lift off the tapered collar (fitted to certain models) from the front of the outer bearing and then

prise out the two oil seals using a screwdriver. Now lift out the inner bearing spacer, the two taper roller bearings and the distance piece.

**21** Using a suitable drift, tap out the two bearing outer races from each side of the hub.

**22** Thoroughly clean the bearings and swivel hub using paraffin or a suitable solvent and dry with a lint-free rag. Remove any burrs or score marks from the hub bore with a fine file or scraper.

**23** Carefully examine the bearing outer races, the rollers and roller cages for pitting, scoring, or cracks, and if at all suspect renew the bearings. It will also be necessary to renew the oil seals as they will have been damaged during removal.

**24** Begin reassembly by refitting the bearing outer races to the hub, with their smaller diameter toward the hub centre. Press the outer races into the hub using a tube of suitable diameter and a vice, or very carefully tap them into place using a brass drift. Ensure that the race does not tip slightly and bind as it is being installed. If this happens, the outer race will crack so take great care to keep it square. The outer race must seat firmly against the shoulder in the centre of the hub when fitted.

**25** Pack the two roller bearings with a high melting-point grease and position them in their outer races with the distance piece in between.

**26** Install the two new oil seals with their sealing lips inwards and use a tube of suitable diameter to tap them fully home. Note that there is a spacer fitted behind the inner oil seal and that the inner seal also has a second lip on its inner circumference.

**27** Position the tapered collar over the outer bearing (where fitted), and refit the swivel hub assembly to the car as described in Section 3. When refitting the swivel hub, ensure that the water shield on the driveshaft is packed with grease around its sealing face and positioned 6.35 mm from the end of the shaft.

## 5 Front swivel hub balljoints - removal and refitting



### Removal

**1** Remove the swivel hub assembly as described in Section 3 and mount it firmly in a vice, with the balljoint requiring attention uppermost.

**2** Remove the rubber dust cover, tap back the lockwasher, and using a large socket or box spanner, undo and remove the domed retaining nut.

**3** Lift off the ball-pin, ball-pin seat, and if working on the lower balljoint assembly, the ball-pin seat tension spring.

**4** Lift off the shims located over the lockwasher, then remove the grease nipple and lift away the lockwasher.

**5** Clean all the components thoroughly and

then carefully inspect the ball-pin, ball-pin seat and domed nut for pitting, score marks or corrosion.

**6** If the components are worn, a balljoint repair kit, consisting of new ball-pin, ball-pin seat, spring, shims, lockwasher and retaining nut should be obtained from your dealer. If the old parts are in a satisfactory condition they may be re-used and any slackness that may have been previously felt in the joint can be taken up by adjustment of the shim sizes.

### Refitting

**7** Before final reassembly of the balljoint, it is necessary to determine the correct number and size of shims required to provide a snug fit of the ball-pin with the domed retaining nut fully tightened. This is done in the following way.

**8** Place the lockwasher in position and refit the grease nipple. Now place all the available shims over the lockwasher and then refit the ball-pin seat, the ball-pin and domed retaining nut. Assemble all the parts without grease at this stage, and if working on the lower balljoint do not fit the ball-pin seat tension spring.

**9** Fully tighten the retaining nut and then check the movement of the ball-pin. With all the available shims fitted, it should be quite slack with considerable up-and-down movement.

**10** Using a trial and error process, remove the retaining nut, take out a shim and then refit the nut and recheck the movement of the ballpin. Continue doing this until it is possible to move the ball-pin in all directions, without binding, but with slight resistance to movement being felt.

**11** Dismantle the joint again, lubricate all the parts with general purpose grease and finally reassemble the joint. If working on the lower assembly, the ball-pin seat tension spring should now be fitted (see illustrations).

**12** Tighten the retaining nut fully, check that the ball-pin still moves freely with only slight resistance, and if satisfactory bend up the lockwasher to secure the retaining nut (see illustrations).

**13** Refit the rubber dust cover to the balljoint (see illustration) and then refit the swivel hub as described in Section 3.

## 6 Front lower suspension arm - removal and refitting



### Removal

**1** Working under the wheel arch, undo and remove the single retaining screw and lift out the upper suspension arm rebound rubber. Position a solid packing piece of approximately the same thickness in its place (see illustration 3.1).

**2** Chock the rear wheels then jack up the front of the car and support it on axle stands (see "Jacking and vehicle support"). Remove the front roadwheel.





5.11a Fit the lockwasher ...



5.11b ... spring ...



5.11c ... ball-pin seat ...



5.11d ... and shims



5.12a Refit the ball-pin and nut ...



5.12b ... screw in the grease nipple ...



5.12c ... and fully tighten the nut



5.12d Bend up the lockwasher ...



5.13 ... and fit the dust cover

**3** Undo and remove the nut and washer securing the swivel hub balljoint to the lower suspension arm. Release the taper of the balljoint shank using a universal balljoint separator, or the alternative method described in Section 3 paragraph 5.

**4** Move the lower suspension arm downwards to disengage the balljoint shank.

**5** Undo and remove the nut and bolt securing the tie-bar to the suspension arm and then move the tie-bar sideways out of the way.

**6** Undo and remove the nut and washer from the rear of the pivot bolt securing the lower suspension arm to the subframe (see illustration).

**7** Lever the pivot bolt forward and off the subframe, then lift out the lower suspension arm.

**8** Lift the rubber bushes off the suspension arm and inspect them carefully for swelling, cracks or deterioration of the rubber. Also inspect the pivot bolt for wear or damage. Renew any worn components.

### Refitting

**9** Refitting is the reverse sequence to removal, bearing in mind the following points:

- a) Ensure that the flat of the pivot bolt head locates under the tab on the subframe.
- b) Tighten all nuts and bolts to the specified torque.
- c) Do not fully tighten the pivot bolt retaining nut until the car has been lowered to the ground.



6.6 Lower suspension arm inner mounting



7.2 Tie-bar front mounting

**7 Front suspension tie-bar - removal and refitting**



**Removal**

- 1 Chock the rear wheels then jack up the front of the car and support it on axle stands (see "Jacking and vehicle support"). Remove the front roadwheel.
- 2 Undo and remove the locknut securing the front end of the tie-bar to the subframe (see illustration). Now lift off the thrustwasher and the rubber thrust bush.
- 3 Undo and remove the bolt, nut and spring washer securing the other end of the tie-bar to the lower suspension arm. Disengage the tie-bar from the suspension arm and subframe, then lift it off the car. Slide the remaining rubber thrust bush off the tie-bar end.
- 4 Carefully inspect the tie-bar thrust bushes for swelling, compression damage or deterioration of the rubber and check the tie-bar for straightness and elongation of the mounting bolt holes. Also check the securing bolt for wear of its shank. If any of the components are defective a new tie-bar kit should be obtained from your local dealer.

**Refitting**

- 5 Refitting is the reverse sequence to removal.

**8 Front upper suspension arm - removal and refitting**



**Note:** Before carrying out this operation on cars fitted with Hydrolastic suspension, it will be necessary to have the Hydrolastic system depressurised by a Rover dealer. If working on cars equipped with rubber cone suspension, Rover special tool 18G574B will be required to compress the rubber cone.

**Removal**

- 1 Chock the rear wheels then jack up the front of the car and support it on axle stands (see "Jacking and vehicle support"). Remove the front roadwheel.



8.6 Subframe tower mounting bolt fitted to later models

- 2 Undo and remove the nut and washer securing the swivel hub balljoint to the upper suspension arm. Release the taper of the balljoint shank using a universal balljoint separator, or the alternative method described in Section 3, paragraph 5.

**Models with Hydrolastic suspension**

- 3 Undo and remove the single retaining screw and lift out the upper suspension arm rebound rubber.
- 4 Lift up the rubber dust cover around the knuckle joint located on the top of the upper suspension arm. Withdraw the ball end of the knuckle joint from its seat in the upper arm and then prise the shank of the knuckle joint out of the displacer unit using a screwdriver. The shank of the knuckle joint is a simple push fit in the displacer unit; however, corrosion may make it initially tight to remove. Recover the spacer (where fitted) from the shank.

**Models with rubber cone suspension**

- 5 Undo and remove the nut and flat washer securing the shock absorber to the upper suspension arm. Now move the shock absorber sideways until it is clear of the mounting stud.
- 6 Working in the engine compartment, undo and remove the two bolts (or nuts) securing the subframe tower to the bulkhead

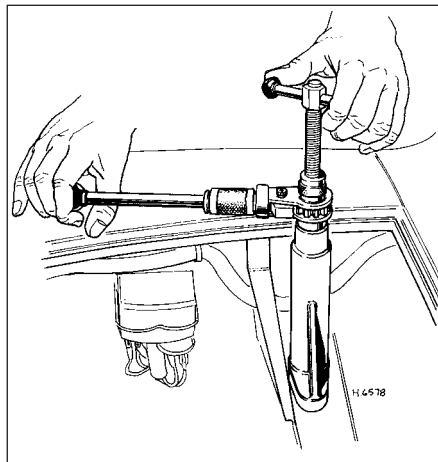

8.7 Use of special tool to compress rubber cone spring

crossmember. Lift off the locking plate and then refit the bolts (or nuts). On later models undo and remove the large hexagon-headed plug that is used instead of the two bolts or nuts (see illustration).

7 It is now necessary to compress the rubber cone spring using service tool 18G574B as follows. Position the body of the tool over the two subframe tower retaining bolts (or nuts) and turn the tool centre screw, nine complete turns, to engage the threads in the rubber cone. Now turn the ratchet handle of the tool until it contacts the tool body. Hold the centre screw and turn the ratchet handle clockwise until all tension is removed from the strut which interconnects the rubber cone and the upper suspension arm (see illustration).

- 8 Undo and remove the single retaining screw and lift out the upper suspension arm rebound rubber.
- 9 Lift up the rubber dust cover around the knuckle joint located at the base of the spring strut.
- 10 Withdraw the ball end of the knuckle joint from its seat in the upper arm and then lift out the spring strut assembly from the rubber cone. If it is tight, prise it out using a screwdriver (see illustration).

**All models**

- 11 Undo and remove the nut and spring washer from each end of the upper arm pivot shaft.
- 12 Undo and remove the two nuts, bolts and spring washers securing the pivot shaft thrust collar retaining plate, thrust collar and seal and then withdraw the pivot shaft forward and out of the upper suspension arm.

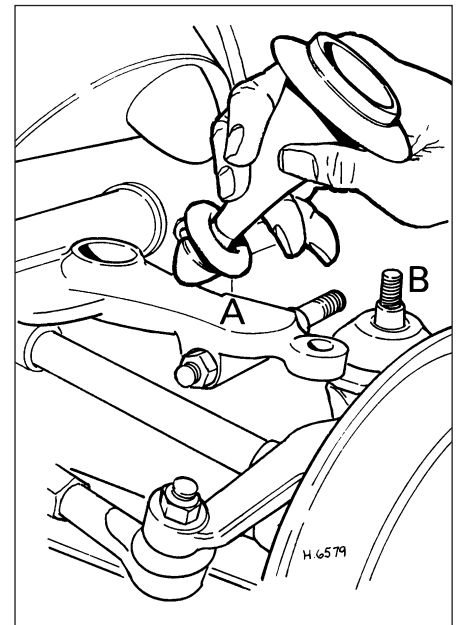

8.10 Suspension strut removal - rubber cone spring suspension

- A Upper suspension arm
- B Upper swivel hub balljoint

**13** Now take out the rear thrust collar and seal and then manipulate the upper arm out of the subframe.

**14** With the upper arm removed, inspect the pivot shaft and the needle roller bearings for wear, and if necessary renew them. The needle roller bearings can be removed from the upper arm by tapping them out of each side using a long thin drift inserted through the other side. Press in new bearings using a vice, or drift them in using a tube of suitable diameter or a shouldered mandrel. Ensure that the marked ends of the bearings face outwards.

**15** Also carefully inspect the ball end of the knuckle joint and its plastic cup seat in the upper arm. If the ball end is corroded, worn or pitted or if the plastic cup seat is cracked or worn, renew the joint. The plastic cup seat can be removed by prising out with a screwdriver. The new knuckle joint will be supplied fully assembled and the plastic cup seat can be fitted to the arm with the joint in this condition. The rubber dust cover and ball end will then have to be removed to allow refitment of the upper arm.

### Refitting

**16** Refitting is the reverse sequence to removal bearing in mind the following points:

- Lubricate all parts with general purpose grease during reassembly.
- If the original knuckle joint is being refitted, pack the cup seat with Dextragrease Super GP (or a suitable alternative) available from Rover dealers.
- Ensure that the dust cover is correctly located over the knuckle joint cup, when refitting, otherwise dirt and road grit will enter the joint.
- Ensure that all nuts and bolts are tightened to the specified torque.
- On models with Hydrolastic suspension, do not drive the car (except to your nearest Rover dealer) until the system has been repressurised.

## 9 Front suspension rubber cone spring - removal and refitting



### Removal

- Remove the front upper suspension arm as described in Section 8.
- The service tool (18G574B) used to compress the rubber cone must now be released by turning the ratchet anti-clockwise until all tension in the rubber cone is released.
- Unscrew the service tool and withdraw the rubber cone from its location in the subframe.

### Refitting

- Refitting is the reverse sequence to removal.



11.2a Shock absorber upper ...



11.2b ... and lower mounting

## 10 Front suspension Hydrolastic displacer unit - removal and refitting



### Removal

- Remove the front upper suspension arm as described in Section 8.
- Using two large spanners, undo and remove the displacer hose from the transfer pipe union on the engine compartment bulkhead.
- Push the displacer unit upward, undo and remove the two screws securing the displacer retaining bracket to the subframe tower.
- Rotate the displacer anti-clockwise and withdraw it from its location on the subframe.

### Refitting

- Refitting is the reverse sequence to removal. When installing the displacer, rotate it clockwise to engage the registers on the locating plate.

## 11 Front shock absorber (models with rubber cone suspension) - removal and refitting



### Removal

- Chock the rear wheels then jack up the front of the car and support it on axle stands (see "Jacking and vehicle support"). Remove the front roadwheel.
- Undo and remove the shock absorber upper and lower retaining nut and washers and lift off the shock absorber (see illustrations).
- Examine the shock absorber for leaks or damage of the outer casing. Hold the shock absorber upright and fully compress and extend it six times. Now slowly extend and compress it again. If "dead" areas are apparent, if there is free travel when changing direction, or if the unit is damaged or leaking, it must be renewed.

### Refitting

- Refitting is the reverse sequence to removal. Hold the shock absorber in an upright position and fully compress and extend it six times to expel any air before fitting.

## 12 Front subframe mountings - renewal



**Note:** The following information is applicable to later models equipped with bonded rubber mountings between the front subframe and vehicle underbody. The mountings can be renewed with the subframe in position as follows.

### Front mountings

- Chock the rear wheels then jack up the front of the car and support it on axle stands (see "Jacking and vehicle support").
- Support the subframe with a jack on the side to be released.
- Undo and remove the nut and bolt securing the mounting to the subframe and the nut and bolt securing the mounting to the body (see illustration).
- Undo and remove the two nuts and bolts securing the subframe to the rear mounting.
- Lower the jack slightly, lever the subframe rearwards, and extract the front mounting. Collect any shims that may be fitted between the mounting and the subframe.

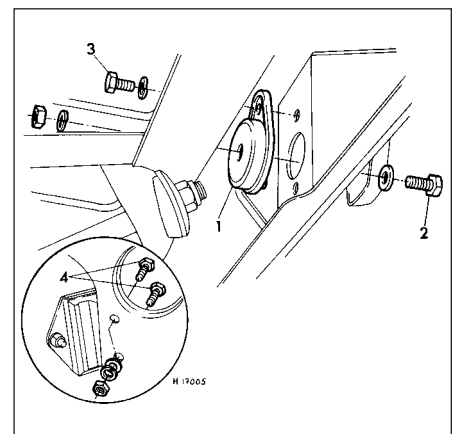

12.3 Front subframe mountings

- Front mounting
- Mounting-to-subframe retaining bolt
- Mounting-to-body retaining bolt
- Rear mounting-to-subframe retaining bolts



6 Refitting is the reverse sequence to removal. With the mounting attached to the body, it is important to measure the gap between the rear of the mounting and the subframe, and then to select an appropriate number of shims of the same thickness for fitting in the gap. The shims are slotted and square in shape, and are 1.32 mm thick. They are located over the mounting bolt shanks.

**Rear mounting**

7 Chock the rear wheels then jack up the front of the car and support it on axle stands (see "Jacking and vehicle support").

8 Support the subframe with a jack on the side to be released.

9 Undo and remove the two nuts and bolts securing the subframe to the mounting.

10 Lift up the carpets inside the car and have an assistant hold the two bolts securing the mounting to the body. Undo and remove the nuts from below and lift off the mounting.

11 Refitting is the reverse sequence to removal.

**13 Front subframe - removal and refitting**



The front subframe, complete with engine/transmission and all suspension components still in position, can be removed from the car using the procedure described in Chapter 2B. With the engine/transmission lifted off, the suspension components can then be withdrawn by referring to the relevant Sections of this Chapter.

**14 Rear hub bearings - renewal**



1 Chock the front wheels then jack up the rear of the car and support it on axle stands (see "Jacking and vehicle support"). Remove the rear roadwheel, then release the handbrake.

2 Slacken off the brake adjuster, unscrew the two brake drum retaining screws and lift off the drum. If it is tight, tap it gently using a soft-faced mallet.

3 By judicious tapping and levering, extract the hub cap and withdraw the retaining split pin from the hub securing nut (see illustration).

4 Using a large socket, undo and remove the hub securing nut and thrustwasher. Note that the left-hand hub nut has a left-hand thread and the right-hand hub nut has a right-hand thread.

5 Withdraw the hub from the stub axle using a hub puller. Alternatively, lever it off using two stout screwdrivers or flat bars.

6 With the hub assembly removed from the car, prise out the rear oil seal, then tap out the two bearing inner races using a brass drift. Take care not to lose the balls which will be released as the inner races are removed. On certain models, taper roller bearings are fitted and the inner races are simply lifted out.

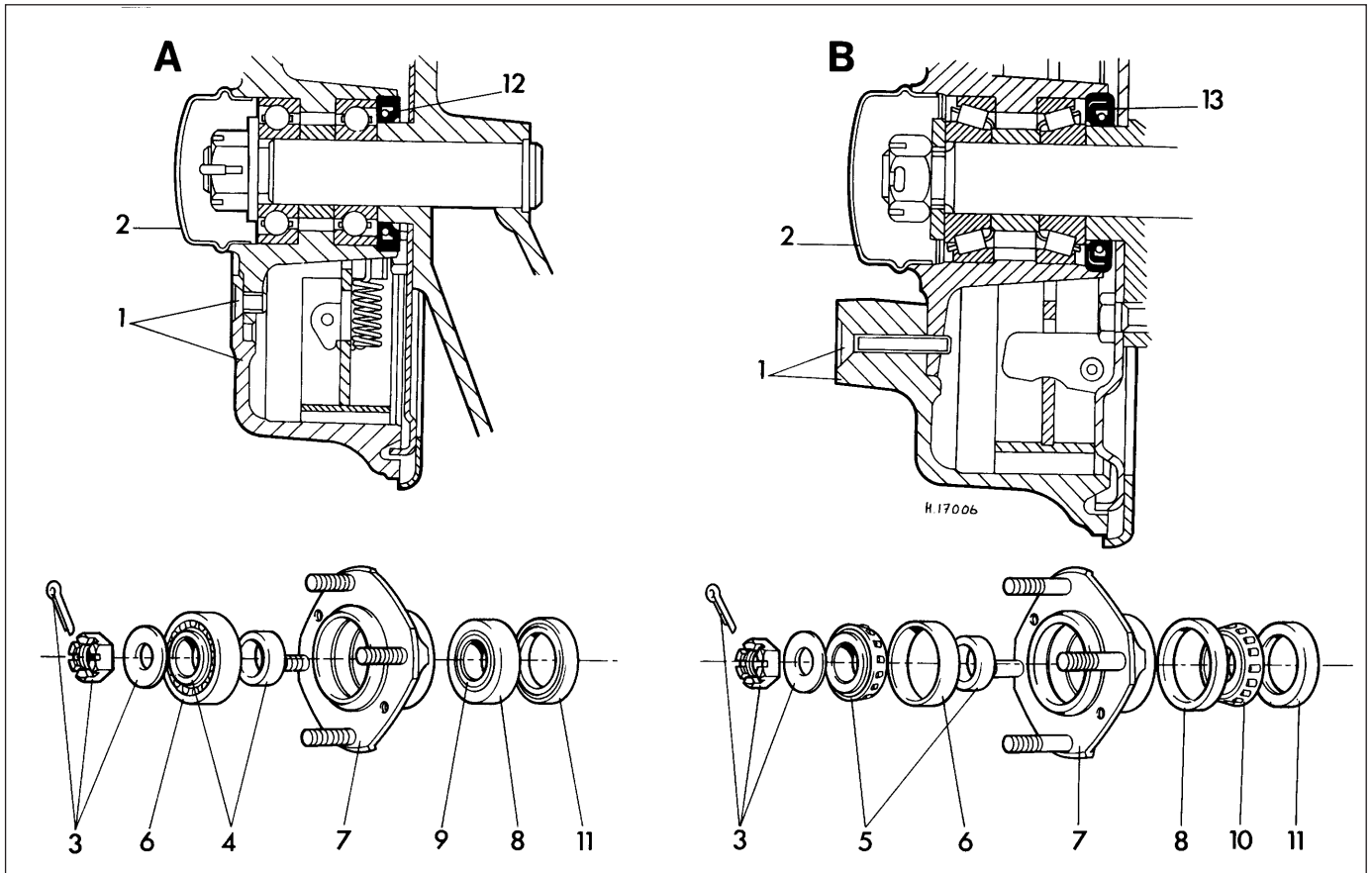

14.3 Exploded view of the rear hub components

A Ball bearing type

B Taper roller bearing type

1 Brake drum and retaining screw

2 Hub cap

3 Hub retaining nut assembly

4 Outer ball bearing inner race and spacer

5 Outer taper roller bearing inner race and spacer

6 Outer bearing outer race

7 Rear hub

8 Inner bearing outer race

9 Inner ball bearing inner race

10 Inner taper roller bearing inner race

11 Oil seal

12 Oil seal installed with lips facing inwards

13 Oil seal installed with lips facing outwards





**15.3 Remove the rear rubber cone spring strut . . .**

**7** Withdraw the distance piece (if fitted) located between the two bearings and then drive out the two outer races away from the hub centre.

**8** Thoroughly clean all the parts in paraffin or a suitable solvent and dry with a lint-free cloth.

**9** Carefully examine the bearing inner and outer races, and the ball cage and balls for scoring, pitting or wear ridges; renew as necessary. The hub oil seal must be renewed as it will have been damaged during removal. If the bearings are in a satisfactory condition, reassemble the balls and ball cage to the outer race and then press the inner race back into position.

**10** Before refitting the bearings remove any burrs that may be present in the bore of the hub. Use a fine file or scraper.

**11** Pack the bearings using a general purpose lithium based grease and fit the inboard bearing to the hub with the narrow edge of the bearing outer race facing away from the hub centre. Press or tap the bearing into position, using the outer race only, with a tube of suitable diameter until the bearing abuts the shoulder in the hub. Take great care to keep the bearing square as it is installed, otherwise it will jam in the hub bore, and could cause the outer race, to crack.

**12** Fit a new oil seal to the rear of the hub with its lip facing *towards* the bearing. On models fitted with taper roller bearings, the oil seal lip faces *away* from the bearing.

**13** Place the distance piece in position and fit the outboard bearing into the hub, again ensuring that the narrow edge of the bearing outer race faces away from the hub centre.

**Note:** Some makes of plain ball-bearings have lengthened inner races which butt against each other. In this case the bearing distance piece is no longer needed.

**14** With the bearings installed, refit the hub to the stub axle and gently tap it home using a soft-faced mallet. Ensure that the stub axle squarely enters the distance piece between the two bearings.

**15** Place the thrustwasher over the stub axle, chamfered side toward the bearing, then refit the securing nut and tighten it to the specified torque. Align the next split pin hole and fit a new split pin.



**15.4 . . . and rubber cone spring**

**16** Refit the hub cap, brake drum and roadwheel, readjust the brakes (see Chapter 1) then lower the car to the ground.

**15 Rear rubber cone spring - removal and refitting**



**Removal**

**1** Chock the front wheels then jack up the rear of the car and support it on axle stands (see "Jacking and vehicle support"). Remove the rear roadwheel.

**2** Support the radius arm using a jack or block of wood, then undo and remove the shock absorber retaining locknut and washers from the arm. Slide the end of the shock absorber off the radius arm stud then remove the jack and lower the arm as far as it will go.

**3** Using a screwdriver or thin flat bar, prise the rear end of the spring strut out of the rubber cone (see illustration). Now disengage the ball end of the knuckle joint at the front of the spring strut from its seat and lift the strut off the car.

**4** The rubber cone spring can now be levered off its location in the subframe and withdrawn from the car (see illustration).

**Refitting**

**5** Before refitting the rubber cone spring, drift the ball end of the knuckle joint out of its location in the spring strut; examine it and its

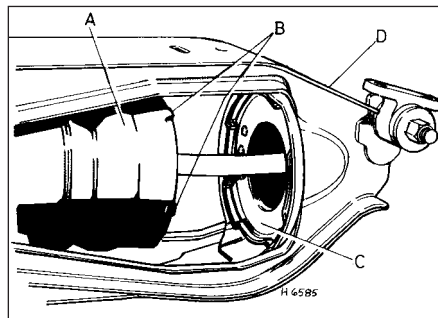

**16.9 Rear Hydro-lastic displacer unit separated from locating plate**

- A Displacer unit
- B Locating lugs
- C Locating plate
- D Subframe

seat in the radius arm for scoring, corrosion and damage. Renew the complete knuckle joint if worn. If the joint is in a satisfactory condition, pack the cup seat with Dextragrease GP (or a suitable alternative) available from Rover dealers, then refit the ball end of the knuckle joint to the cup seat. Ensure that the rubber dust cover is correctly located, otherwise water and grit will enter the joint.

**6** The remainder of refitting is the reverse sequence to removal. When refitting the shock absorber, be sure that the spring strut and knuckle joint are properly engaged as the radius arm is raised.

**16 Rear Hydro-lastic displacer unit - removal and refitting**



**Note:** To enable the displacer unit to be removed it will first be necessary to have the Hydro-lastic system depressurised by a Rover dealer.

**Removal**

**1** Chock the front wheels then jack up the rear of the car and support it on axle stands (see "Jacking and vehicle support"). Remove the rear roadwheel.

**2** Place a block of wood or a jack beneath the rear radius arm, then undo and remove the nut, spring and flat washers securing the helper spring to the radius arm.

**3** Lower the radius arm as far as it will go.

**4** Undo and remove the single retaining screw and lift the bump rubber off the subframe.

**5** Disconnect the flexible Hydro-lastic hose from its union at the rear of the subframe.

**6** Pull the displacer strut rearwards to disengage the knuckle joint ball from its seat, then withdraw the strut from the displacer unit.

**7** Rotate the displacer anti-clockwise and lift it from its location on the subframe.

**Refitting**

**8** Before refitting the displacer unit, examine the knuckle joint ball end (assuming that it was released from its seat as the strut was removed) and seat for scoring, pitting or corrosion. Renew the complete knuckle joint if worn. If the joint is in a satisfactory condition, pack the cup seat with Dextragrease GP (or a suitable alternative) available from Rover dealers, then refit the ball end of the knuckle joint to the cup seat. Ensure that the rubber dust cover is correctly located, otherwise water and grit will enter the joint.

**9** The remainder of refitting is the reverse sequence to removal, bearing in mind the following points:

- a) When installing the displacer, turn it clockwise to lock it into the registers on the subframe locating plate (see illustration).



17.3 Remove the shock absorber lower . . .



17.4 . . . and upper mounting

- b) As the radius arm is lifted to refit the helper spring, ensure that the strut correctly locates in the knuckle joint and displacer.
- c) When refitting is complete, have the Hydrolastic system repressurised at your nearest Rover dealer.

**17 Rear shock absorber (models with rubber cone suspension) - removal and refitting**



**Removal**

- 1 Chock the front wheels then jack up the rear of the car and support it on axle stands (see "Jacking and vehicle support"). Remove the rear roadwheel.
- 2 If removing the left-hand shock absorber on Saloon models, or either of the rear shock absorbers on Cooper S models equipped with twin fuel tanks, it will first be necessary to remove the fuel tank(s) as described in the relevant Part of Chapter 4.
- 3 Support the radius arm using a jack or block of wood, then undo and remove the shock absorber retaining locknut and washers from the radius arm (see illustration).
- 4 Working inside the car or luggage compartment, lift off the protective rubber cap, then undo and remove the two locknuts from the upper end of the shock absorber (see illustration).
- 5 Lift off the thrustwasher and rubber bush, and then withdraw the shock absorber from under the car.
- 6 Examine the shock absorber for leaks or damage to the outer casing. Hold the shock absorber upright, and fully compress and extend it six times. Now slowly compress and extend it once more. If "dead" areas are apparent, if there is free travel when changing direction, or if the unit is damaged or leaking, it must be renewed.

**Refitting**

- 7 Refitting is the reverse sequence to removal. Hold the shock absorber in an upright position and fully compress and extend it six times to expel any air before installing.

**18 Rear helper spring (models with Hydrolastic suspension) - removal and refitting**



The procedure is the same as described in Section 17 for removal and refitting of the shock absorber.

**19 Rear radius arm - removal and refitting**



**Note:** Before carrying out this operation on cars fitted with Hydrolastic suspension, it will be necessary to have the Hydrolastic system depressurised by a Rover dealer.

**Removal**

- 1 Remove the rear shock absorber as described in Section 17 if working on vehicles fitted with rubber cone suspension, or the rear helper spring (Section 18) if Hydrolastic suspension is fitted.
- 2 Lower the radius arm as far as it will go. When working on vehicles fitted with rubber cone suspension, extract the spring strut from the cone spring. Then pull the strut rearwards, to disengage the ball end of the knuckle joint from its cup seat in the radius arm. If Hydrolastic suspension is fitted, pull the displacer strut rearwards to disengage the strut from the knuckle joint (or the ball end of the knuckle joint from its seat) and then move the strut forwards and out of the displacer unit.



19.7 The small distance piece is fitted to the handbrake moving sector

- 3 Undo and remove the retaining screws and lift off the finisher panel from the end of the body side sills (where fitted).
- 4 On models fitted with Hydrolastic suspension, undo and remove the retaining screw and lift off the bump rubber from the subframe.
- 5 Clamp the flexible brake hose, located over the top of the radius arm, with a brake hose clamp or self-gripping wrench with jaws suitably protected. Now undo the union nut securing the metal pipe to the hose and undo and remove the nut securing the hose to its bracket. Plug the ends of the hose and pipe after removal to prevent dirt ingress.
- 6 Extract the split pin and withdraw the clevis pin securing the end of the handbrake cable to the brake operating lever. Detach the cable and tension spring from the bracket at the rear of the brake backplate.
- 7 The handbrake cable moving sector is secured to the front of the radius arm either by a through-bolt and lower locknut, or by an upper retaining spire clip, thrustwasher and spring washer. In the case of the through-bolt, undo and remove the lower locknut and then remove the sector from the bolt. Take care not to lose the small distance tube from the centre of the sector (see illustration). If the sector is retained by a spire clip, prise the clip off the upper end of the pivot pin, lift off the washers and then withdraw the sector and pivot from the radius arm.
- 8 From underneath the car undo and remove the radius arm pivot shaft inner retaining nut and spring washer. Undo and remove the pivot shaft outer retaining nut and washer.
- 9 Undo and remove the four bolts securing the radius arm outer bracket to the subframe. Note that two of these bolts can only be removed using a socket and extension or box spanner inserted between the radius arm and subframe or bracket (see illustration). Lift away the bracket.
- 10 Carefully lift the radius arm off the subframe, taking care not to lose the thrustwashers and rubber seal fitted at each end of the radius arm pivot shaft.
- 11 If there is any doubt about the condition of the radius arm pivot bearings, they should be inspected as follows.



19.9 Rear radius arm outer bracket retaining bolts (subframe shown removed)



19.12a Lift off the radius arm bearing rubber seal . . .



19.12b . . . and thrustwasher . . .

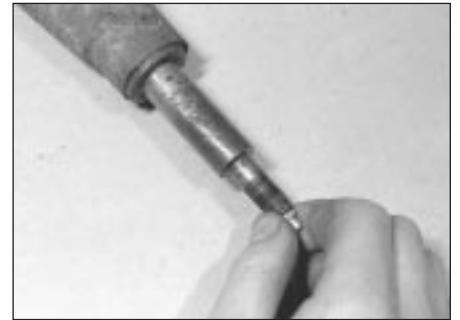

19.12c . . . then slide out the pivot shaft

12 Lift off the rubber seal and thrustwasher from each end of the pivot shaft and then slide the pivot shaft out of the bearings (see illustrations).

13 Wipe away all traces of grease from the pivot shaft and the bearings, and carefully inspect these components. Signs of wear will be most obvious on the pivot shaft in the form of scoring, pitting, wear, ridges or deterioration of the surface hardening. If any of these conditions are apparent, the shaft and bearings require renewal.

14 The removal and refitting of both the bearings, and the line reaming of the bronze bearing to suit the outside diameter of the pivot shaft, entails the use of several special tools. As there is no other way of satisfactorily carrying out this work, it is strongly recommended that the arm is taken to a Rover dealer for the complete bearing removal, refitting and reaming to be carried out.

### Refitting

15 Refitting is the reverse sequence to removal bearing in mind the following points:

- a) When refitting the ball end of the knuckle joint to the seat in the radius arm, pack the cup seat with Dextragrease GP (or a suitable alternative) available from Rover dealers.
- b) Bleed the hydraulic system at the disconnected side as described in Chapter 9.
- c) When refitting is complete, have the Hydrolastic system repressurised at your nearest Rover dealer.

## 20 Rear subframe mountings - renewal



**Note:** The subframe front and rear mountings and rubber bushes can be renewed with the subframe still in position in the car as described below.

### Front mounting

1 Remove the relevant radius arm assembly from the car as described in Section 19.

2 Undo and remove the nut and washer securing the support bolt to the subframe.

3 Undo and remove the two bolts and spring washers securing the mounting to the body.

4 Lever the subframe down slightly and lift off the mounting assembly.

5 The support bolt and rubber bushes can now be removed from the mounting.

6 Refitting is the reverse sequence to removal, noting that the step in the mounting and the short bolt must be at the top (where applicable).

### Rear mounting

7 Chock the front wheels then jack up the rear of the car and support it on axle stands (see "Jacking and vehicle support"). Remove the rear roadwheel.

8 Undo and remove the nut and washer securing the mounting to the subframe.

9 On Estate, Van and Pick-up models, undo and remove the two bolts securing the mounting to the body. On Saloon models have an assistant hold the bolts from inside the luggage compartment while the retaining nuts are removed from below.

10 Lever the subframe down slightly and slide the mounting assembly sideways and off the subframe.

11 The rubber bushes can now be removed from the mounting.

12 In all cases, refitting is the reverse sequence to removal, noting that the step in the mounting and the short bolt must be at the front.



21.3 Remove the handbrake cable adjusting nuts

## 21 Rear subframe - removal and refitting



**Note:** Corrosion of the rear subframe is a common occurrence on Minis, particularly older models, and is one of the main causes of MOT test failure on these cars. Where corrosion has reached an advanced stage, renewal of the subframe is the only satisfactory cure. Despite its reputation for being an extremely difficult task, removal of the rear subframe is in fact a fairly straightforward operation. Before carrying out this work on cars fitted with Hydrolastic suspension, it will be necessary to have the system depressurised by a Rover dealer.

### Removal

1 Chock the front wheels then jack up the rear of the car and support it on axle stands (see "Jacking and vehicle support").

2 Where the battery positive lead is routed through the subframe, disconnect the negative, then the positive lead from the battery terminals and pull the positive lead clear of the frame, noting its routing for reference when refitting.

3 On early models undo and remove the two adjusting nuts securing the ends of the two handbrake cables to the trunnion on the handbrake lever (see illustration). Pull the cables out of the trunnion and then slide off the washers and tension spring. **Note:** On later models a single front cable is used and the tension springs are omitted.

4 Lift up the carpets to expose the cable guide plates located at the point where the cable passes through the floor.

5 Engage the help of an assistant to hold the nuts from underneath the car while the cable guide retaining screws are removed from above (see illustrations). Lift off the guides and sealing pads, and from underneath the car, pull the ends of the cable through the opening in the floor and out of the passenger compartment.

6 Remove the brake master cylinder reservoir filler cap and place a piece of polythene over



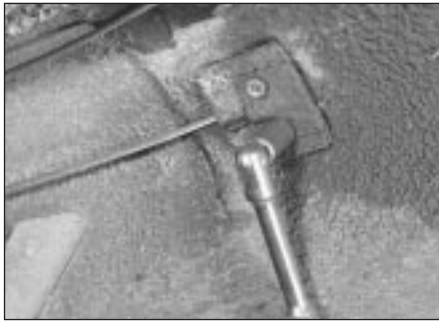

21.5a Hold the cable guide retaining nuts from below . . .

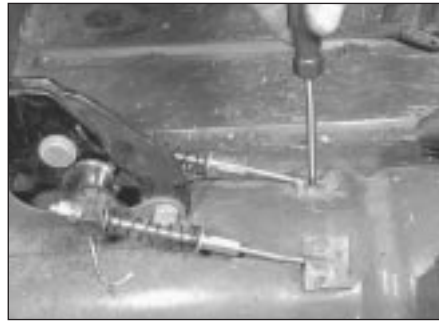

21.5b . . . and unscrew from above

**Note:** During this operation, clamp the hoses using a self-gripping wrench with suitably protected jaws to prevent loss of fuel. Plug both hoses with a bolt or suitable metal rod upon removal.

**10** On models fitted with Hydrolastic suspension, undo and remove the transfer pipe unions from the pressure valves at the rear of the subframe.

**11** Place a block of wood under the rear wheels or jack up the radius arms slightly. From inside the car or luggage compartment, undo and remove the shock absorber upper mounting on models with rubber cone suspension, or the helper spring upper mounting on models with Hydrolastic suspension. On Saloon cars, it will be necessary to detach the fuel tank retaining strap and move the tank slightly to provide access to the left-hand mounting.

**12** Undo and remove the retaining screws and lift off the finisher panels from each end of the body side sills (where fitted).

**13** Place a jack under each side of the subframe, or a trolley jack in the centre, with a substantial plank of wood running transversely across the subframe, and just take the weight of the frame on the jacks.

the filler neck, then refit the cap. This will help prevent fluid loss when the rear pipes are disconnected.

**7** From underneath the rear of the car, undo and remove the brake hydraulic pipe union from the centre of the pressure regulating valve on early models. On models equipped with a dual circuit braking system, unscrew the pipe unions at the pipe connectors on each side of the subframe front crossmember. On later dual circuit systems unscrew the pipe union from the three-way connector on the rear subframe.

**8** Refer to Chapter 4C if necessary and remove the complete exhaust system from the car.

**9** If an electric fuel pump is fitted, disconnect the electrical leads, slacken the clips and detach the fuel inlet and outlet hoses from the pump.



**Warning:** Refer to the precautions contained in Chapter 4A, Section 1 before carrying out any work on the fuel system.

fuel system.

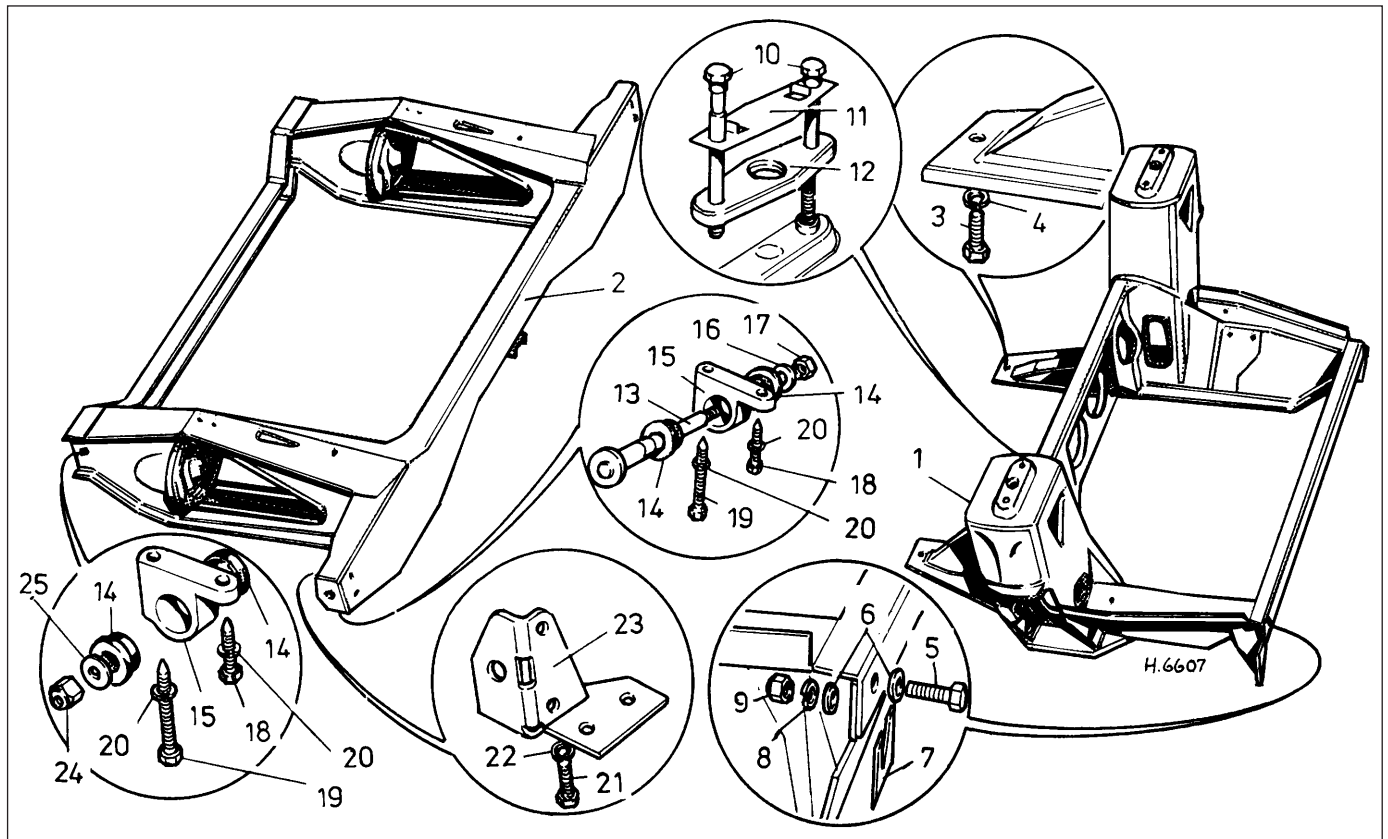

21.14 Exploded view of the front and rear subframe assemblies

- |                  |                 |                 |           |            |
|------------------|-----------------|-----------------|-----------|------------|
| 1 Front subframe | 6 Washer        | 11 Washer       | 16 Washer | 21 Screw   |
| 2 Rear subframe  | 7 Packing piece | 12 Pressure pad | 17 Nut    | 22 Washer  |
| 3 Screw          | 8 Washer        | 13 Support pin  | 18 Screw  | 23 Bracket |
| 4 Washer         | 9 Nut           | 14 Bush         | 19 Screw  | 24 Nut     |
| 5 Bolt           | 10 Screw        | 15 Mounting     | 20 Washer | 25 Washer  |





**22.1** Prise up the central motif for access to the steering wheel nut on later models

**14** Undo and remove the two bolts securing each of the four subframe mountings to the body (see illustration). If the bolts are tight, use liberal amounts of penetrating oil on them and allow time for the oil to soak.

**15** With the mounting bolts removed, engage the help of an assistant to steady the subframe and then slowly lower the jacks until the subframe can be withdrawn from the rear of the car.

**16** With the subframe removed from the car it can now be completely dismantled by referring to the relevant Sections and Chapters of this manual.

**Refitting**

**17** Refitting is the reverse sequence to removal, bearing in mind the following points:

- a) Line up the subframe mountings and fit the bolts finger tight first, before progressively tightening.

b) Bleed the complete hydraulic system on completion as described in Chapter 9.

c) On models fitted with Hydrolastic suspension, have the system repressurised at your nearest Rover dealer.

**22 Steering wheel - removal and refitting**



**Removal**

**1** Depending on model, either undo and remove the retaining screws and lift off the trim, or carefully prise up the steering wheel central motif (see illustration).

**2** Using a suitable socket or box spanner, undo and remove the nut which retains the wheel on the steering column.

**3** Recover the retaining nut lockwasher and then lift the steering wheel off the splines on the column.



*If the wheel is tight, tap it up near the centre, using the palm of your hand, or twist it from side to side, whilst pulling upwards to release it from the shaft splines.*

**Refitting**

**4** Make sure that the roadwheels are in the straight-ahead position and that the small triangle on the direction indicator switch bush

is pointing toward the horn push (later models only).

**5** Refit the steering wheel to the column with the wheel spokes centralised.

**6** Refit the lockwasher and retaining nut, then tighten the nut to the specified torque.

**7** Refit the trim or central motif.

**23 Steering column - removal and refitting**



**Removal**

**1** Disconnect the battery negative lead.

**2** Undo and remove the screws securing the two halves of the steering column shroud to the column and lift off the shroud.

**3** Disconnect the electrical wiring multiplug connectors located under the parcel shelf (see illustration).

**4** At the base of the column, undo and remove the pinch-bolt securing the inner column clamp to the pinion shaft.

**5** Undo and remove the upper column support clamp bolt at the parcel shelf. On later models where a shear bolt is used, cut a slot in the bolt and use a screwdriver to unscrew it, or drill a small hole and remove it with a stud extractor.

**6** Position the roadwheels in the straight-ahead position, pull the column upwards and remove it from the car.

**Refitting**

**7** Make sure that the roadwheels are still in the straight-ahead position.

**8** Lift up the front carpets and slacken the steering rack U-bolt locknuts sufficiently to allow sideways movement of the rack housing.

**9** Slacken the upper column support clamp mounting bracket bolts, to allow movement of the bracket.

**10** Lift out the rubber grommet in the passenger side floor, then remove the plastic plug from the rack housing. Insert a 6 mm diameter centralising pin (a bolt or drill bit are ideal) into the hole (see illustration). Move

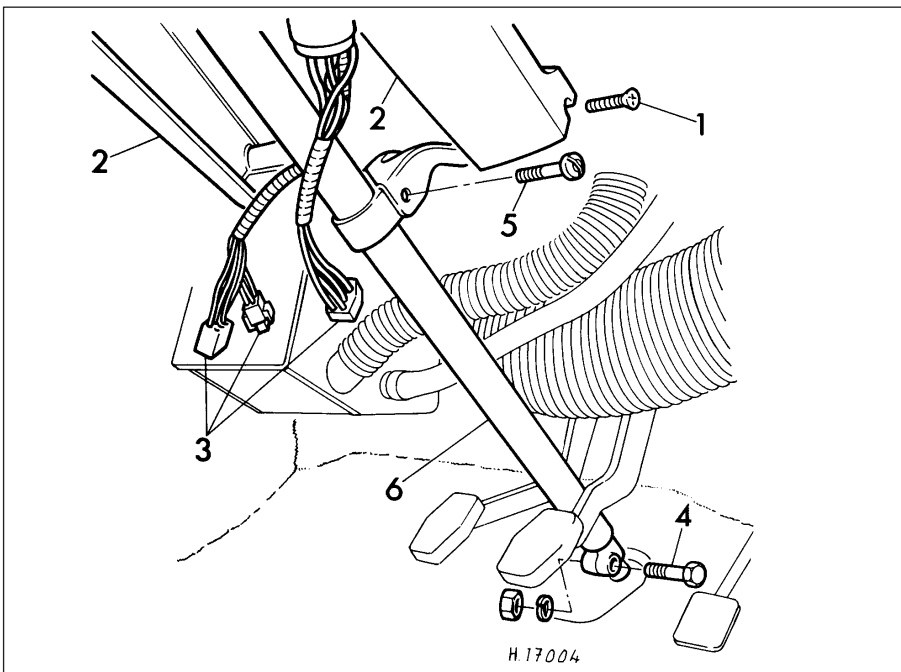

**23.3** Steering column removal

- 1 Column shroud retaining screw
- 2 Column shroud halves
- 3 Multi-plug connectors
- 4 Pinch-bolt
- 5 Upper column support clamp bolt
- 6 Steering column

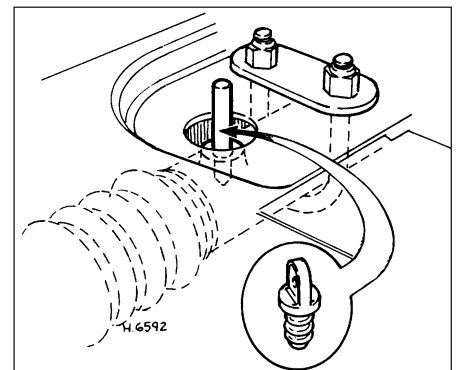

**23.10** Use of a dowel to centralise the steering rack

*Inset shows plastic plug*

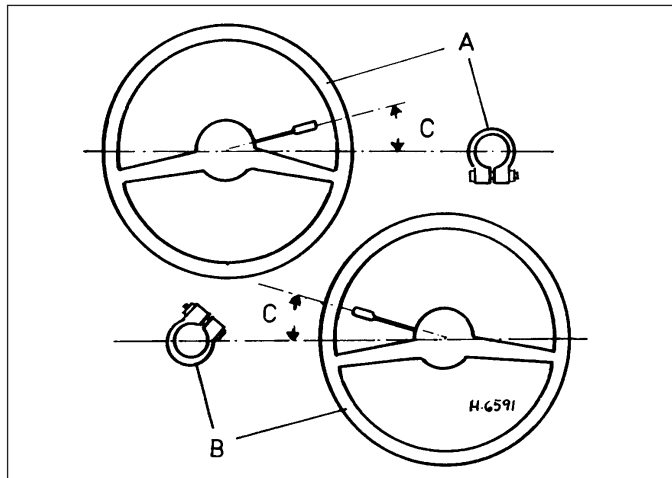

**23.17 Correct position of clamp bolt and direction indicator lever when refitting the early type steering column**

A RHD models      B LHD models      C = 20°

the rack sideways slightly until the pin fully engages with the hole in the rack, thus centralising the assembly. Engage the steering inner column clamp with the pinion shaft ensuring that the steering wheel spokes are horizontal/centre spoke vertical.

**11** Refit the column clamp bolt and then remove the centralising pin. Refit the plastic plug and grommet.

**12** Refit the upper column support clamp bolt, using a new shear bolt on later models. Ensure that there is no twist or strain on the column as the bolt is inserted. Reposition the clamp and bracket if necessary.

**13** The remainder of the refitting procedure now varies according to model year as described below.

#### Models with single stalk multi-function switch

**14** Tighten the steering column clamp and bracket retaining bolts and the steering rack U-bolt locknuts to the specified torque.

**15** Reconnect the electrical multiplugs under the parcel shelf.

**16** Adjust the direction indicator switch cancelling stud so that it just trips the switch levers as the wheel is turned.

**17** With the roadwheels in the straight ahead position and the steering column installed, the direction indicator stalk should be at 20° to the horizontal, with the cancelling levers of the switch (see illustration). If this is not the case, slacken the steering column support bracket clamp and rotate the column as necessary.

**18** Refit the steering column shrouds and the carpets, then reconnect the battery.

#### Models with twin stalk multi-function switch

**19** Position the outer column to give 2 mm clearance between the steering wheel hub and the boss of the multi-function switch, then tighten the shear bolt until the head breaks off.

**20** Reconnect the electrical multiplugs under the parcel shelf.

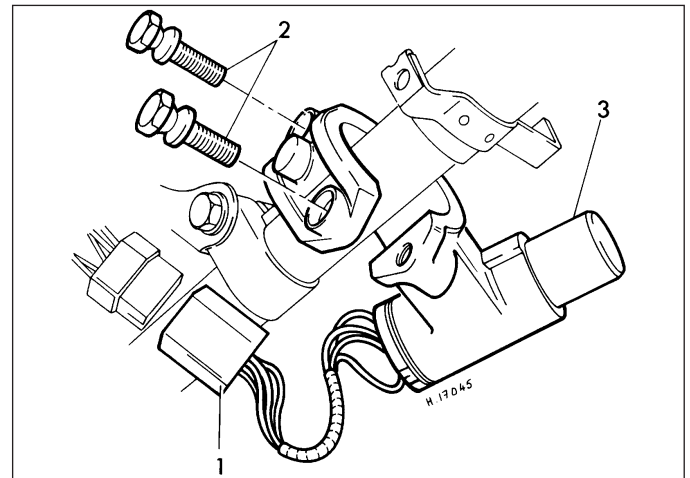

**24.6 Steering lock/ignition switch assembly**

A Multiplug connector      2 Shear bolts      3 Steering lock/ignition switch

**21** Refit the steering column shrouds and the carpets, then reconnect the battery.

### 24 Steering column - dismantling and reassembly



#### Dismantling

**1** With the steering column removed from the car as described in Section 23, remove the steering wheel as described in Section 22.

**2** Undo and remove the retaining screws and withdraw the multi-function switch from the column.

**3** On early models, undo and remove the direction indicator cancelling stud and locknut from the inner column.

**4** The inner column can now be withdrawn from the lower end of the outer column tube. Before doing this insert the ignition key into the switch and turn it to the I position. This will release the steering lock and allow the inner column to be removed.

**5** Prise the top bush out of the column if necessary using a screwdriver. The lower felt bush is removed by simply sliding it out of the outer column.

**6** To remove the steering lock/ignition switch, drill out the shear bolt heads, or alternatively drill a hole in the shear bolts and unscrew them using a stud extractor (see illustration). The clamp plate and lock switch assembly can then be removed.

**7** With the steering column assembly dismantled, check the inner and outer column for straightness by rolling them on a flat surface. Renew the parts if distortion is obvious.

#### Reassembly

**8** Begin reassembly by lubricating the upper polythene bush with graphite grease. Insert the bush into the top of the outer column,

chamfered end first. Tap the bush fully into position, ensuring that the shouldered slot engages with the detent in the outer column.

**9** Insert the inner column into the lower end of the outer column and slide it in approximately half way.

**10** Soak the lower felt bush in engine oil and then wrap it around the inner column until its ends are butted together. Now carefully slide the inner column fully home.

**11** Refit the multi-function switch assembly, and on early models the direction indicator cancelling stud and locknut.

**12** Refit the steering lock ignition switch using new shear bolts. Do not shear the heads off the bolts until the steering column has been refitted and the operation of the steering lock tested.

**13** Refit the steering column to the car as described in Section 23 then, when the column is correctly positioned in relation to the steering gear, refit the steering wheel (Section 22).

### 25 Steering tie-rod outer balljoint - removal and refitting



#### Removal

**1** Chock the rear wheels then jack up the front of the car and support it on axle stands (see "Jacking and vehicle support"). Remove the front roadwheel.

**2** Slacken the locknut securing the balljoint to the steering tie-rod by a quarter of a turn.

**3** Undo and remove the balljoint shank locknut and separate the taper of the shank using a universal balljoint separator or the alternative method described in Section 3, paragraph 5.

**4** Hold the steering tie-rod with a self-gripping wrench and unscrew the balljoint from the tie-rod, counting the number of turns necessary to remove it.

## Refitting

**5** Screw the new balljoint onto the tie-rod by the same number of turns as counted during removal.

**6** Clean the taper surfaces then fit the balljoint shank to the steering arm. Refit and tighten the shank locknut to the specified torque.



*If difficulty is experienced in tightening the balljoint shank locknut due to the tapered shank turning in the steering arm, apply pressure with a jack or long lever to the underside of the balljoint to lock the taper in its conical seat.*

**7** Tighten the locknut securing the balljoint to the steering tie-rod

**8** Refit the roadwheel and lower the car to the ground.

**9** On completion, have the front wheel toe setting checked (see Section 30).

## 26 Steering rack rubber gaiter - removal and refitting



## Removal

**Note:** *Should the rubber gaiters at each end of the steering rack become damaged, split or show any other signs of deterioration, they must be renewed immediately, otherwise the lubricant will be lost from the rack unit, and water and road grit will enter the assembly, causing rapid internal wear.*

**1** Remove the steering tie-rod outer balljoint as described in Section 25.

**2** Mark the position of the locknut on the tie-rod so that it can be refitted in the same place, then unscrew it from the tie-rod.

**3** Place a suitable container beneath the rubber gaiter to catch any oil that may spill from the rack (early models only).

**4** Undo and remove the two retaining clips or cut off the wire clips, then slide the gaiter off the rack housing and tie-rod.

## Refitting

**5** Refitting is the reverse sequence to removal. With the gaiter in position refill the rack with the appropriate lubricant, as described in Section 29, before refitting the retaining clips or wire.

## 27 Rack-and-pinion steering gear - removal and refitting



**Note:** *The rack-and-pinion steering gear is secured to the front floor of the car by U-bolts and locknuts. To enable the steering gear to be removed, it will be necessary to lower the rear of the front subframe by approximately 76 mm to provide the necessary working clearances.*

## Removal

**1** Remove the air cleaner assembly as described in the relevant Part of Chapter 4.

**2** Undo and remove the nuts and bolts securing the exhaust pipe-to-manifold clamp. Lift off the clamp. On Cooper S models, remove the complete exhaust system as described in Chapter 4C.

**3** Undo and remove the bolt securing the engine tie-rod to the side of the cylinder block.

**4** Detach the clutch operating lever return spring, then undo and remove the two bolts securing the clutch slave cylinder to the flywheel housing. Tie the slave cylinder out of the way from a convenient place on the bulkhead.

**5** Undo and remove the two bolts (or nuts) each side securing the subframe towers to the bulkhead crossmember. On later models undo and remove the large hexagon-headed plug used in place of the bolts or nuts.

**6** Working inside the car, undo and remove the securing screws and lift off the two halves of the steering column shroud.

**7** Undo and remove the nut and bolt securing the inner column clamp to the steering gear pinion shaft.

**8** Slacken the upper column clamp bolt at the parcel shelf bracket. To do this cut a slot in the shear bolt head and unscrew it with a screwdriver.

**9** Lift the complete steering column upwards until the inner column clamp is disengaged from the pinion shaft.

**10** Lift up the carpets and then undo and remove the four steering rack U-bolt locknuts.

**11** Chock the rear wheels then jack up the front of the car and support it on axle stands (see "Jacking and vehicle support"). Remove the front roadwheels.

**12** From underneath the car, undo and remove the nut and bolt securing the exhaust pipe support to the bracket on the side of the transmission.

**13** On manual transmission models fitted with a remote control gearchange, undo and remove the bolts securing the rear of the remote control housing to the floor. On automatic transmission models it should be possible to lower the subframe sufficiently for removal of the steering gear without disconnecting the gear selector cable. However, if during subsequent operations the cable appears to be under tension, disconnect it from the transmission as described in Chapter 7B.

**14** On models with rubber cone suspension, disconnect the front shock absorbers from the upper suspension arms.

**15** Undo and remove the locknuts securing the steering tie-rod outer balljoint shanks to the steering arms on the swivel hubs. Release the tapers using a universal balljoint separator or the alternative method described in Section 3, paragraph 5.

**16** Support the subframe securely on jacks and then undo and remove the nuts and bolts securing the subframe to the rear mountings or to the floor.

**17** Slacken the bolt securing the front of the subframe or subframe mountings to the body.

**18** Carefully lower the jacks, allowing the subframe to drop by approximately 76 mm at the rear.

**19** Lift off the rack-and-pinion retaining U-bolts and clamp pads and then manoeuvre the rack assembly out from between the subframe and body on the driver's side.

## Refitting

**20** Refitting is the reverse sequence to removal bearing in mind the following points:

a) *Do not tighten the U-bolt locknuts until the upper column is fitted and secure.*

b) *When refitting the upper column to the pinion shaft and mountings, refer to the procedure described in Section 23.*

## 28 Rack-and-pinion steering gear - dismantling, inspection and reassembly



**Note:** *It is not possible to make any adjustments to the rack-and-pinion steering gear unless it is removed from the car. With it removed, it is as well to dismantle and examine the whole unit before making any adjustments. This will save having to remove the unit again later because of initial non-detection of wear. If wear is very bad it is advisable to fit an exchange reconditioned unit. It must be pointed out that dismantling and reassembly of the steering gear is rather involved and may be beyond the scope of the average DIY enthusiast. Read through the complete Section first to familiarise yourself with the procedure and ensure that the necessary tools and equipment are available before proceeding.*

## Dismantling

**1** Mark the position of the locknuts on the tie-rods so that the toe-out is approximately correct on reassembly.

**2** Slacken the locknuts and, gripping the tie-rods firmly with a self-gripping wrench, unscrew the tie-rod outer balljoints. Now unscrew the locknuts also.

**3** If the steering gear is fitted with black rubber gaiters, it will be filled with oil. If it is fitted with transparent rubber gaiters it will be filled with grease. If working on the oil-filled type ensure that a container is available before proceeding further.

**4** Unscrew the clips or cut the wires that secure the rubber gaiters to the rack housing and tie-rods. Carefully remove the gaiters, and on oil-filled types, drain the oil from the housing.

**5** On inspection it will be seen that the ball housing at the inner end of each tie-rod is secured to the rack by a locking collar. The

locking collar is then peened into a groove in the ball housing on early models, or retained by a grooved pin on later types.

**6** On early models punch or prise up the peening and then unlock the ball housing and collar using Rover special tool No 18G1278. Alternatively, use two small Stilson wrenches, but take care not to damage the housing and collar faces.

**7** On later models, it is first necessary to drill out the grooved pin. To do this use a 3.97 mm diameter drill, and drill to a depth of 4 mm. Now unlock the ball housing and collar using the procedure described in the previous paragraph.

**8** Unscrew the ball housing and then lift off the tie-rod, ball seat and spring from the end of the rack. The locking collar can now be removed.

**9** Repeat this procedure for the other tie-rod, noting that if these components are to be re-used they must be refitted to the same side of the rack from which they were removed.

**10** At the base of the pinion housing, undo and remove the two rack damper cover bolts and spring washers. Lift off the damper cover together with its shims, and then withdraw the thrust spring, yoke, and O-ring seal from the rack housing.

**11** Undo and remove the two bolts and lift off the pinion end cover together with its gasket and shims.

**12** Carefully push out the pinion and lower bearing.

**13** Withdraw the rack from the pinion end of the housing. **Note:** *If the rack is withdrawn from the plain end of the housing the rack teeth will damage the support bush.*

**14** Extract the pinion upper bearing from the rack housing, followed by the oil seal.

**15** From the plain end of the rack housing, undo and remove the small retaining screw and then withdraw the rack support bush.

**Note:** *On some models a rivet is used instead of a screw and this must be carefully drilled out.*

**Inspection**

**16** Thoroughly clean all the parts with paraffin or a suitable solvent and dry with a lint-free cloth. Carefully inspect the teeth on the rack and the pinion for chipping, roughness, uneven wear, hollows, or fractures. Renew both components if either is badly worn.

**17** Carefully inspect the component parts of the inner balljoints for wear or ridging, and renew as necessary.

**18** The outer tie-rod balljoints cannot be dismantled, and if worn must be renewed as complete assemblies. Examine the component parts of the damper and renew any that show signs of wear. Pay particular attention to the oil seals; as a precautionary measure it is always best to renew them.

**19** The rubber gaiters are particularly prone to damage and it is advisable to renew them as a matter of course.

**Reassembly**

**20** Begin reassembly by refitting the rack support bush to the plain end of the rack housing. If the original bush is being refitted, align the screw holes in the bush and rack housing.

**21** If a new rack support bush is being fitted, drill a 2.7 mm diameter hole into the bush, through the retaining screw hole, to a depth of 10.5 mm (see illustration).

**22** Apply jointing compound to the threads of the support bush retaining screw. Refit and tighten the screw, then check that the bush bore has not distorted. Make sure that the screw does not break right through the bush into the bore.

**23** Lubricate the upper pinion bearing and fit it into place in the housing (see illustration). Use the pinion to push the bearing fully into position.

**24** Insert the rack into the housing from the pinion end and then refit the pinion, splined end first.

**25** Lubricate the lower pinion bearing and place it in position on the lower end of the pinion shaft.

**26** Refit the preload shims, using additional shims if necessary, until the shim pack stands proud of the pinion housing.

**27** Refit the end cover and retaining bolts and tighten the bolts lightly and evenly until all pinion endfloat is taken up.

**28** Using feeler blades, measure the gap between the end cover and the pinion housing. Now take off the end cover and remove the appropriate number of shims until a gap of 0.28 to 0.33 mm still remains.

**29** With the correct shims in position, refit the end cover using a new gasket, and with the bolt threads lightly coated in jointing compound, tighten them fully.

**30** Place a new oil seal over the pinion and insert it into the housing. The seal must be fitted with the seal lips toward the pinion bearing and with its top face flush with the end of the housing.

**31** Lubricate the rack damper yoke and slide it into the housing. Refit the cover plate and retaining bolts, but do not fit the spring at this stage.

**32** Tighten the cover plate bolts evenly until the rack is lightly clamped by the yoke. Turn the pinion two or three turns in either direction and check that the rack is not binding in any position. If necessary, slacken the cover plate bolts slightly to achieve this.

**33** Take a feeler blade measurement of the gap between the damper cover plate and the housing and then remove the cover plate.

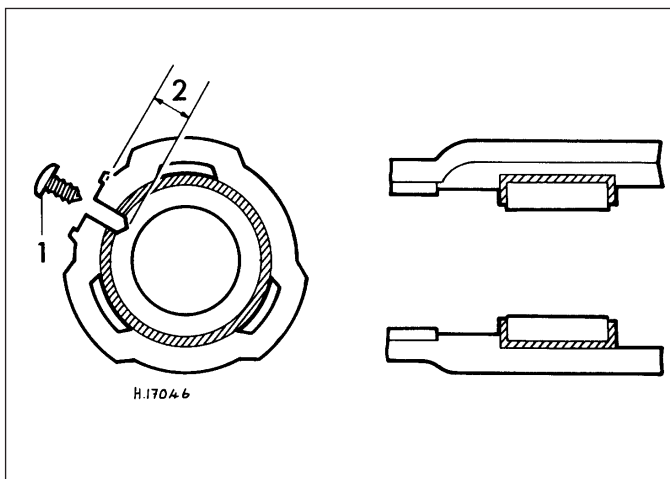

**28.21 Refitting the rack support bush**

- 1 Retaining screw
- 2 Drill to a depth of 10.5 mm

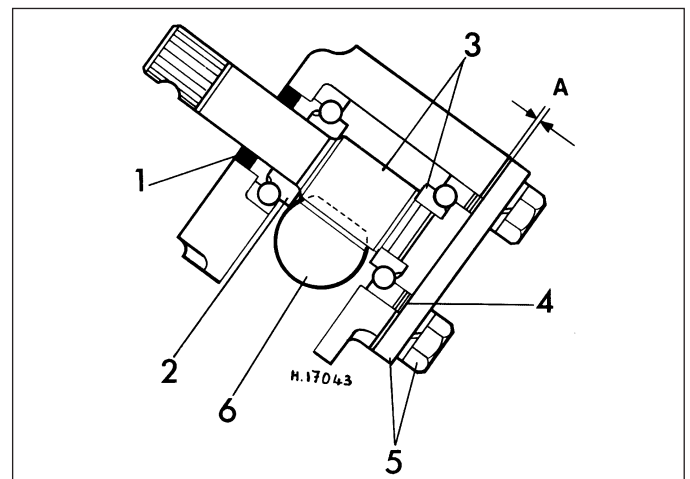

**28.23 Reassembly of the pinion housing**

- 1 Oil seal
- 2 Upper pinion bearing
- 3 Pinion and lower bearing
- 4 Preload shims
- 5 End cover and retaining bolt
- 6 Rack
- A = 0.28 to 0.33 mm



**34** Fit a new O-ring seal to the damper yoke and place the spring in position. Add shims equal to the gap measured between the cover plate and housing plus 0.05 to 0.13 mm. Refit the cover plate and tighten down the bolts. Turn the pinion through 180° in each direction from the centre and make sure there is no tightness or binding.

**35** Screw one of the tie-rod ball housing locking collars onto the rack as far as it will go. If the original components are being re-used, make sure that the collar is being refitted to the end of the rack from which it was removed.

**36** Lubricate the thrust spring and ball seat and then locate them in the end of the rack. Lubricate the tie-rod balljoint and the ball housing and refit these components.

**37** Tighten the ball housing until the tie-rod ball is clamped and will not move without binding.

**38** Now slacken the ball housing slightly (approximately one eighth of a turn) until the tie-rod is just free to move. **Note:** *The tie-rod will still feel stiff to move because of the tension of the thrust spring, but there should be no trace of binding or endfloat.*

**39** Hold the ball housing in this position and screw the locking collar into contact with it. Tighten the locking collar using the same procedure used for removal, making sure that the position of the ball housing does not alter.

**40** If working on early type racks,peen the edge of the locking collar into the groove of the ball housing using a small punch.

**41** On later type racks, protect the rack housing from swarf and drill a 3.97 mm diameter hole, 8.0 mm deep, between the locking collar and ball housing. The hole must be drilled on the side facing away from the rack teeth and at least 90° away from any previous hole. **Note:** *The rack may be drilled a maximum of three times only. With the hole drilled, drive in a new grooved pin and retain it by peening over the edge of the hole.*

**42** Repeat the above procedure for the other tie-rod and ball housing.

**43** Refit the rubber gaiter and retaining clips or wire to the plain end of the rack assembly.

**44** Stand the assembly upright and fill it through the pinion end of the housing with the correct quantity and type of lubricant as shown in the *Specifications*.

**45** Refit the remaining rubber gaiter and its retaining clips or wire.

**46** If the original tie-rods have been refitted, screw on the tie-rod outer balljoint locknuts to the positions marked during dismantling. Now screw on the balljoints and tighten the locknuts.

**47** If new tie-rods have been fitted, screw on the locknuts and then screw on the balljoints, by an equal amount each side, until the dimension between their centres is as shown in the *Specifications*. Tighten the locknuts.

**48** The steering gear can now be refitted to the car as described in Section 27. It will be necessary to have the front toe setting checked and reset as described in Section 30 after refitting.

## 29 Rack-and-pinion steering gear - lubrication



**1** The steering gear is filled with lubricant during manufacture and then sealed. Additional lubricant will only be required in service if a leak develops, either from the rubber gaiters or from any of the joints, or if the steering gear has been dismantled.

**2** The steering gear fitted to early models, identified by black rubber gaiters, is filled with oil. The steering gear fitted to later models, identified by transparent rubber gaiters, is filled with grease. The grade and quantity of lubricant for both types is given in the *Specifications*.

**3** Should it be necessary to refill the rack, proceed as follows.

**4** Jack up the driver's side of the car and suitably support it on stands (see "*Jacking and Vehicle Support*"). Remove the front roadwheel.

**5** Centralise the steering gear so that the wheels are in the straight-ahead position.

**6** Slacken the retaining clips or remove the wire securing the rubber gaiter to the rack housing and tie-rod. Slide the rubber gaiter down the tie-rod sufficiently to provide access.

**7** Using an oil can or grease gun filled with the specified grade and quantity of lubricant, fill the rack housing.

**8** Refit the rubber gaiter and secure it with the retaining clips or soft iron wire.

**9** Turn the steering from lock to lock to distribute the lubricant, refit the roadwheel and lower the car to the ground.

## 30 Wheel alignment and steering angles - general information

### General

**1** A car's steering and suspension geometry is defined in four basic settings - all angles are expressed in degrees (toe settings are also expressed as a measurement); the relevant settings are camber, castor, swivel hub inclination, and toe-setting. Front wheel toe-setting is readily adjustable but all other settings are established during manufacture and will not normally require attention. It is possible to alter the front castor angle by fitting a longer or shorter tie-bar to the relevant side, and to alter the rear wheel toe setting by fitting spacers between the rear radius arm outer brackets and the subframe. Should there be any reason to suspect that the front castor angle is incorrect (insensitive steering, pulling to one side etc) or the rear wheel toe setting is incorrect (excessive rear tyre wear) then the settings should be checked and if necessary altered by a Rover dealer.

## Front wheel toe setting - checking and adjustment

**2** Due to the special measuring equipment necessary to accurately check the wheel alignment, and the skill required to use it properly, checking and adjustment is best left to a Rover dealer or similar expert. Note that most tyre-fitting shops now possess sophisticated checking equipment. The following is provided as a guide, should the owner decide to carry out a DIY check.

**3** The front wheel toe setting is checked by measuring the distance between the front and rear inside edges of the roadwheel rims. Proprietary toe measurement gauges are available from motor accessory shops. Adjustment is made by screwing the tie-rod outer balljoints in or out of their tie-rods, to alter the effective length of the tie-rod assemblies.

**4** For **accurate** checking, the vehicle **must** be at kerb weight, ie unladen and with a full tank of fuel, and on models with Hydrolastic suspension, the trim height must be correct (see Section 2).

**5** Before starting work, check the tyre pressures and tread wear, the condition of the hub bearings, the steering wheel free play, and the condition of the front suspension components (see Chapter 1). Correct any faults found.

**6** Park the vehicle on level ground, check that the front roadwheels are in the straight-ahead position, then rock the rear and front ends to settle the suspension. Release the handbrake, and roll the vehicle backwards 1 metre, then forwards again, to relieve any stresses in the steering and suspension components.

**7** Measure the distance between the front edges of the wheel rims and the rear edges of the rims. Subtract the rear measurement from the front measurement, and check that the result is within the specified range.

**8** If adjustment is necessary, apply the handbrake, then jack up the front of the vehicle and support it securely on axle stands (see "*Jacking and vehicle support*"). Turn the steering wheel onto full-left lock, and record the number of exposed threads on the right-hand tie-rod. Now turn the steering onto full-right lock, and record the number of threads on the left-hand side. If there are the same number of threads visible on both sides, then subsequent adjustment should be made equally on both sides. If there are more threads visible on one side than the other, it will be necessary to compensate for this during adjustment. **Note:** *It is most important that after adjustment, the same number of threads are visible on each tie-rod.*

**9** First clean the tie-rod threads; if they are corroded, apply penetrating fluid before starting adjustment. Release the rubber gaiters outboard clips (where necessary), and slide back the gaiters; apply a smear of grease to the gaiter seat on the tie-rod, so that the gaiters will not be twisted or strained as their respective tie-rods are rotated.

## 10•20 Suspension and steering

---

**10** Use a straight-edge and a scribe or similar to mark the relationship of each tie-rod to its outer balljoint then, holding each tie-rod in turn, unscrew its outer balljoint locknut fully.

**11** Alter the length of the tie-rods, bearing in mind the note made in paragraph 8. Screw them into or out of their outer balljoints, rotating the tie-rod using a suitable pair of grips or self-locking wrench. Shortening the tie-rods (screwing them into their outer balljoints) will reduce toe-in/increase toe-out.

**12** When the setting is correct, hold the tie-rods and securely tighten the outer balljoint locknuts. Count the exposed threads to check the length of both tie-rods. If they are not the same, then the adjustment has not been made equally, and problems will be encountered with tyre scrubbing in turns; also, the steering wheel spokes will no longer be horizontal when the wheels are in the straight-ahead position.

**13** If the tie-rod lengths are the same, lower the vehicle to the ground and re-check the toe setting; re-adjust if necessary. When the setting is correct, securely tighten the outer balljoint locknuts. Ensure that the rubber gaiters are seated correctly, and are not twisted or strained, and secure them in position with new retaining clips or wire (where necessary).





# Chapter 11

## Bodywork and fittings

### Contents

Bodywork, paint and exterior trim check . . . . .	See Chapter 1	Front door lock assembly - removal and refitting . . . . .	10
Bodywork seam trim strips - general information . . . . .	30	Front door striker plate - removal and refitting . . . . .	12
Bonnet - removal and refitting . . . . .	13	Front grille - removal and refitting . . . . .	29
Bonnet lock - removal and refitting . . . . .	15	General information . . . . .	1
Bonnet lock release cable - removal and refitting . . . . .	14	Maintenance - bodywork and underframe . . . . .	2
Boot lid - removal and refitting . . . . .	16	Maintenance - upholstery and carpets . . . . .	3
Boot lid lock - removal and refitting . . . . .	17	Major structural damage or corrosion - general information . . . . .	5
Centre console - removal and refitting . . . . .	28	Minor body damage - repair . . . . .	4
Door, boot and bonnet check and lubrication . . . . .	See Chapter 1	Rear door lock (Estate and Van models) - removal and refitting . . . . .	19
Door hinge - removal and refitting . . . . .	8	Rear doors (Estate and Van models) - removal and refitting . . . . .	18
Doors - removal and refitting . . . . .	7	Rear door window (Estate and Van models) - removal and refitting . . . . .	23
Facia top rail cover - removal and refitting . . . . .	27	Rear quarterlight glass (Saloon models) - removal and refitting . . . . .	24
Front and rear bumpers - removal and refitting . . . . .	31	Rear side screen window (Estate models) - removal and refitting . . . . .	25
Front door exterior handle (Saloon and Estate models) - removal and refitting . . . . .	11	Rear window (Saloon and Pick-up models) - removal and refitting . . . . .	22
Front door glass - removal and refitting . . . . .	9	Sunroof components - general information . . . . .	32
Front door interior trim panel (Saloon and Estate models) - removal and refitting . . . . .	6	Tailgate (Pick-up models) - removal and refitting . . . . .	20
		Windscreen - removal and refitting . . . . .	21
		Wooden facia - removal and refitting . . . . .	26

### Degrees of difficulty

<b>Easy</b> , suitable for novice with little experience 	<b>Fairly easy</b> , suitable for beginner with some experience 	<b>Fairly difficult</b> , suitable for competent DIY mechanic 	<b>Difficult</b> , suitable for experienced DIY mechanic 	<b>Very difficult</b> , suitable for expert DIY or professional 
--	---	---	--	---

#### 1 General information

Although the Mini has been produced in many forms since its introduction, the principle of construction has remained the same. The body and floor pan are of a monocoque all-steel, welded construction creating a very strong and torsionally rigid shell. The front and rear suspension assemblies are mounted on subframes, bolted to the underside of the bodyshell. The front subframe also provides mounting points for the engine/transmission.

Although the Mini bodyshell is extremely strong, it is likely to have suffered to some degree, particularly on older models, from the effects of rust and corrosion. Common problem areas are the front wings, body side sills and the rear subframe. Particular attention should be paid to the rear subframe and areas around its mountings, as well as the side sills, as these are load bearing areas; corrosion here, if left unchecked, could seriously affect the roadworthiness of the vehicle. The subframes are covered in detail in Chapter 10 and full information regarding the treatment of rust and corrosion and body repairs will be found in subsequent Sections of this Chapter.

#### 2 Maintenance - bodywork and underframe

The general condition of a vehicle's bodywork is the one thing that significantly affects its value. Maintenance is easy but needs to be regular. Neglect, particularly after minor damage, can lead quickly to further deterioration and costly repair bills. It is important also to keep watch on those parts of the vehicle not immediately visible, for instance the underside, inside all the wheel arches and the lower part of the engine compartment.

The basic maintenance routine for the bodywork is washing preferably with a lot of water, from a hose. This will remove all the loose solids which may have stuck to the vehicle. It is important to flush these off in such a way as to prevent grit from scratching the finish. The wheel arches and underframe need washing in the same way to remove any accumulated mud which will retain moisture and tend to encourage rust. Oddly enough, the best time to clean the underframe and wheel arches is in wet weather when the mud is thoroughly wet and soft. In very wet weather the underframe is usually cleaned of large accumulations automatically and this is a good time for inspection.

Periodically, except on vehicles with a wax-based underbody protective coating, it is a good idea to have the whole of the underframe of the vehicle steam cleaned, engine compartment included, so that a thorough inspection can be carried out to see what minor repairs and renovations are necessary. Steam cleaning is available at many garages and is necessary for removal of the accumulation of oily grime which sometimes is allowed to become thick in certain areas. If steam cleaning facilities are not available, there are one or two excellent grease solvents available which can be brush applied; the dirt can then be simply hosed off. Note that these methods should not be used on vehicles with wax-based underbody protective coating or the coating will be removed. Such vehicles should be inspected annually, preferably just prior to winter, when the underbody should be washed down and any damage to the wax coating repaired using underseal. Ideally, a completely fresh coat should be applied. It would also be worth considering the use of such wax-based protection for injection into door panels, sills, box sections, etc, as an additional safeguard against rust damage where such protection is not provided by the vehicle manufacturer.

After washing paintwork, wipe off with a chamois leather to give an unspotted clear finish. A coat of clear protective wax polish

will give added protection against chemical pollutants in the air. If the paintwork sheen has dulled or oxidised, use a cleaner/polisher combination to restore the brilliance of the shine. This requires a little effort, but such dulling is usually caused because regular washing has been neglected. Care needs to be taken with metallic paintwork as special non-abrasive cleaner/polisher is required to avoid damage to the finish.

Always check that the door and ventilator opening drain holes and pipes are completely clear so that water can be drained out. Bright work should be treated in the same way as paint work. Windscreens and windows can be kept clear of the smeary film which often appears by the use of a proprietary glass cleaner. Never use any form of wax or other body or chromium polish on glass.

### 3 Maintenance - upholstery and carpets



Mats and carpets should be brushed or vacuum cleaned regularly to keep them free of grit. If they are badly stained remove them from the vehicle for scrubbing or sponging and make quite sure they are dry before refitting. Seats and interior trim panels can be kept clean by wiping with a damp cloth and a proprietary upholstery cleaner. If they do become stained (which can be more apparent on light coloured upholstery) use a little liquid detergent and a soft nail brush to scour the grime out of the grain of the material. Do not forget to keep the headlining clean in the same way as the upholstery. When using liquid cleaners inside the vehicle do not over-wet the surfaces being cleaned. Excessive damp could get into the seams and padded interior causing stains, offensive odours or even rot. If the inside of the vehicle gets wet accidentally it is worthwhile taking some trouble to dry it out properly, particularly where carpets are involved. *Do not leave oil or electric heaters inside the vehicle for this purpose.*

### 4 Minor body damage - repair



#### **Repair of minor scratches in bodywork**

If the scratch is very superficial, and does not penetrate to the metal of the bodywork, repair is very simple. Lightly rub the area of the scratch with a paintwork renovator, or a very fine cutting paste, to remove loose paint from the scratch, and to clear the surrounding bodywork of wax polish. Rinse the area with clean water.

Apply touch-up paint to the scratch using a fine paint brush; continue to apply fine layers

of paint until the surface of the paint in the scratch is level with the surrounding paintwork. Allow the new paint at least two weeks to harden: then blend it into the surrounding paintwork by rubbing the scratch area with a paintwork renovator or a very fine cutting paste. Finally, apply wax polish.

Where the scratch has penetrated right through to the metal of the bodywork, causing the metal to rust, a different repair technique is required. Remove any loose rust from the bottom of the scratch with a penknife, then apply rust-inhibiting paint, to prevent the formation of rust in the future. Using a rubber or nylon applicator fill the scratch with bodystopper paste. If required, this paste can be mixed with cellulose thinners, to provide a very thin paste which is ideal for filling narrow scratches. Before the stopper-paste in the scratch hardens, wrap a piece of smooth cotton rag around the top of a finger. Dip the finger in cellulose thinners, and then quickly sweep it across the surface of the stopper-paste in the scratch; this will ensure that the surface of the stopper-paste is slightly hollowed. The scratch can now be painted over as described earlier in this Section.

#### **Repair of dents in bodywork**

When deep denting of the vehicle's bodywork has taken place, the first task is to pull the dent out, until the affected bodywork almost attains its original shape. There is little point in trying to restore the original shape completely, as the metal in the damaged area will have stretched on impact and cannot be reshaped fully to its original contour. It is better to bring the level of the dent up to a point which is about 3 mm below the level of the surrounding bodywork. In cases where the dent is very shallow anyway, it is not worth trying to pull it out at all. If the underside of the dent is accessible, it can be hammered out gently from behind, using a mallet with a wooden or plastic head. Whilst doing this, hold a suitable block of wood firmly against the outside of the panel to absorb the impact from the hammer blows and thus prevent a large area of the bodywork from being "belled-out".

Should the dent be in a section of the bodywork which has a double skin or some other factor making it inaccessible from behind, a different technique is called for. Drill several small holes through the metal inside the area - particularly in the deeper section. Then screw long self-tapping screws into the holes just sufficiently for them to gain a good purchase in the metal. Now the dent can be pulled out by pulling on the protruding heads of the screws with a pair of pliers.

The next stage of the repair is the removal of the paint from the damaged area, and from an inch or so of the surrounding "sound" bodywork. This is accomplished most easily by using a wire brush or abrasive pad on a power drill, although it can be done just as effectively by hand using sheets of abrasive

paper. To complete the preparation for filling, score the surface of the bare metal with a screwdriver or the tang of a file, or alternatively, drill small holes in the affected area. This will provide a really good "key" for the filler paste.

To complete the repair see the Section on filling and re-spraying.

#### **Repair of Rust holes or gashes in bodywork**

Remove all paint from the affected area and from an inch or so of the surrounding "sound" bodywork, using an abrasive pad or a wire brush on a power drill. If these are not available a few sheets of abrasive paper will do the job just as effectively. With the paint removed you will be able to gauge the severity of the corrosion and therefore decide whether to renew the whole panel (if this is possible) or to repair the affected area. New body panels are not as expensive as most people think and it is often quicker and more satisfactory to fit a new panel than to attempt to repair large areas of corrosion.

Remove all fittings from the affected area except those which will act as a guide to the original shape of the damaged bodywork (eg headlight shells etc). Then, using tin snips or a hacksaw blade, remove all loose metal and any other metal badly affected by corrosion. Hammer the edges of the hole inwards in order to create a slight depression for the filler paste.

Wire brush the affected area to remove the powdery rust from the surface of the remaining metal. Paint the affected area with rust inhibiting paint; if the back of the rusted area is accessible treat this also.

Before filling can take place it will be necessary to block the hole in some way. This can be achieved by the use of aluminium or plastic mesh, or aluminium tape.

Aluminium or plastic mesh or glass fibre matting is probably the best material to use for a large hole. Cut a piece to the approximate size and shape of the hole to be filled, then position it in the hole so that its edges are below the level of the surrounding bodywork. It can be retained in position by several blobs of filler paste around its periphery.

Aluminium tape should be used for small or very narrow holes. Pull a piece off the roll and trim it to the approximate size and shape required, then pull off the backing paper (if used) and stick the tape over the hole; it can be overlapped if the thickness of one piece is insufficient. Burnish down the edges of the tape with the handle of a screwdriver or similar, to ensure that the tape is securely attached to the metal underneath.

#### **Bodywork repairs - filling and re-spraying**

Before using this Section, see the Sections on dent, deep scratch, rust holes and gash repairs.



Many types of bodyfiller are available, but generally speaking those proprietary kits which contain a tin of filler paste and a tube of resin hardener are best for this type of repair; some can be used directly from the tube. A wide, flexible plastic or nylon applicator will be found invaluable for imparting a smooth and well contoured finish to the surface of the filler.

Mix up a little filler on a clean piece of card or board - measure the hardener carefully (follow the maker's instructions on the pack) otherwise the filler will set too rapidly or too slowly. Using the applicator, apply the filler paste to the prepared area; draw the applicator across the surface of the filler to achieve the correct contour and to level the filler surface. As soon as a contour that approximates to the correct one is achieved, stop working the paste - if you carry on too long the paste will become sticky and begin to "pick up" on the applicator. Continue to add thin layers of filler paste at twenty-minute intervals until the level of the filler is just proud of the surrounding bodywork.

Once the filler has hardened, excess can be removed using a metal plane or file. From then on, progressively finer grades of abrasive paper should be used, starting with a 40 grade production paper and finishing with 400 grade wet-and-dry paper. Always wrap the abrasive paper around a flat rubber, cork, or wooden block - otherwise the surface of the filler will not be completely flat. During the smoothing of the filler surface the wet-and-dry paper should be periodically rinsed in water. This will ensure that a very smooth finish is imparted to the filler at the final stage.

At this stage the "dent" should be surrounded by a ring of bare metal, which in turn should be encircled by the finely "feathered" edge of the good paintwork. Rinse the repair area with clean water, until all of the dust produced by the rubbing-down operation has gone.

Spray the whole repair area with a light coat of primer - this will show up any imperfections in the surface of the filler. Repair these imperfections with fresh filler paste or bodystopper, and once more smooth the surface with abrasive paper. If bodystopper is used, it can be mixed with cellulose thinners to form a really thin paste which is ideal for filling small holes. Repeat this spray and repair procedure until you are satisfied that the surface of the filler, and the feathered edge of the paintwork are perfect. Clean the repair area with clean water and allow to dry fully.

The repair area is now ready for final spraying. Paint spraying must be carried out in a warm, dry, windless and dust free atmosphere. This condition can be created artificially if you have access to a large indoor working area, but if you are forced to work in the open, you will have to pick your day very carefully. If you are working indoors, dousing the floor in the work area with water will help

to settle the dust which would otherwise be in the atmosphere. If the repair area is confined to one body panel, mask off the surrounding panels; this will help to minimise the effects of a slight mis-match in paint colours. Bodywork fittings (eg chrome strips, door handles etc) will also need to be masked off. Use genuine masking tape and several thicknesses of newspaper for the masking operations.

Before commencing to spray, agitate the aerosol can thoroughly, then spray a test area (an old tin, or similar) until the technique is mastered. Cover the repair area with a thick coat of primer; the thickness should be built up using several thin layers of paint rather than one thick one. Using 400 grade wet-and-dry paper, rub down the surface of the primer until it is really smooth. While doing this, the work area should be thoroughly doused with water, and the wet-and-dry paper periodically rinsed in water. Allow to dry before spraying on more paint.

Spray on the top coat, again building up the thickness by using several thin layers of paint. Start spraying in the centre of the repair area and then, with a single side-to-side motion, work outwards until the whole repair area and about 50 mm of the surrounding original paintwork is covered. Remove all masking material 10 to 15 minutes after spraying on the final coat of paint.

Allow the new paint at least two weeks to harden, then, using a paintwork renovator or a very fine cutting paste, blend the edges of the paint into the existing paintwork. Finally, apply wax polish.

### **Plastic components**

With the use of more and more plastic body components by the vehicle manufacturers (eg bumpers, spoilers, and in some cases major body panels), rectification of more serious damage to such items has become a matter of either entrusting repair work to a specialist in this field, or renewing complete components. Repair of such damage by the DIY owner is not really feasible owing to the cost of the equipment and materials required for effecting such repairs. The basic technique involves making a groove along the line of the crack in the plastic using a rotary burr in a power drill. The damaged part is then welded back together by using a hot air gun to heat up and fuse a plastic filler rod into the groove. Any excess plastic is then removed and the area rubbed down to a smooth finish. It is important that a filler rod of the correct plastic is used, as body components can be made of a variety of different types (eg polycarbonate, ABS, polypropylene).

Damage of a less serious nature (abrasions, minor cracks etc) can be repaired by the DIY owner using a two-part epoxy filler repair material. Once mixed in equal proportions, this is used in similar fashion to the bodywork filler used on metal panels. The filler is usually cured in twenty to thirty minutes, ready for sanding and painting.

If the owner is renewing a complete component himself, or if he has repaired it with epoxy filler, he will be left with the problem of finding a suitable paint for finishing which is compatible with the type of plastic used. At one time the use of a universal paint was not possible owing to the complex range of plastics encountered in body component applications. Standard paints, generally speaking, will not bond to plastic or rubber satisfactorily. However, it is now possible to obtain a plastic body parts finishing kit which consists of a pre-primer treatment, a primer and coloured top coat. Full instructions are normally supplied with a kit, but basically the method of use is to first apply the pre-primer to the component concerned and allow it to dry for up to 30 minutes. Then the primer is applied and left to dry for about an hour before finally applying the special coloured top coat. The result is a correctly coloured component where the paint will flex with the plastic or rubber, a property that standard paint does not normally possess.

## **5 Major structural damage or corrosion - general information**



**1** Because the body is built on the monocoque principle and is integral with the underframe, major damage must be repaired by specialists with the necessary welding and hydraulic straightening equipment.

**2** Although subframes are used front and rear, they act in the main as supports and locations for the power units and suspension systems.

**3** If the damage is severe, it is vital that on completion of the repair the body and subframes are in correct alignment. Less severe damage may also have twisted or distorted the body or subframes, although this may not be visible immediately. It is therefore always best on completion of repair to check for twist and squareness to make sure all is well.

**4** To check for twist, position the car on a clean level floor, place a jack under each jacking point, raise the car and take off the wheels. Raise or lower the jacks until the sills are parallel with the ground. Depending where the damage occurred, using an accurate scale, take measurements at the suspension mounting points and if comparable readings are not obtained it is an indication that the body is twisted.

**5** After checking for twist, check for squareness by taking a series of measurements on the floor (**see illustration**). Drop a plumb line and bob weight from various mounting points on the underside of the body and mark these points on the floor with chalk. Draw a straight line between each point and measure and mark the middle of

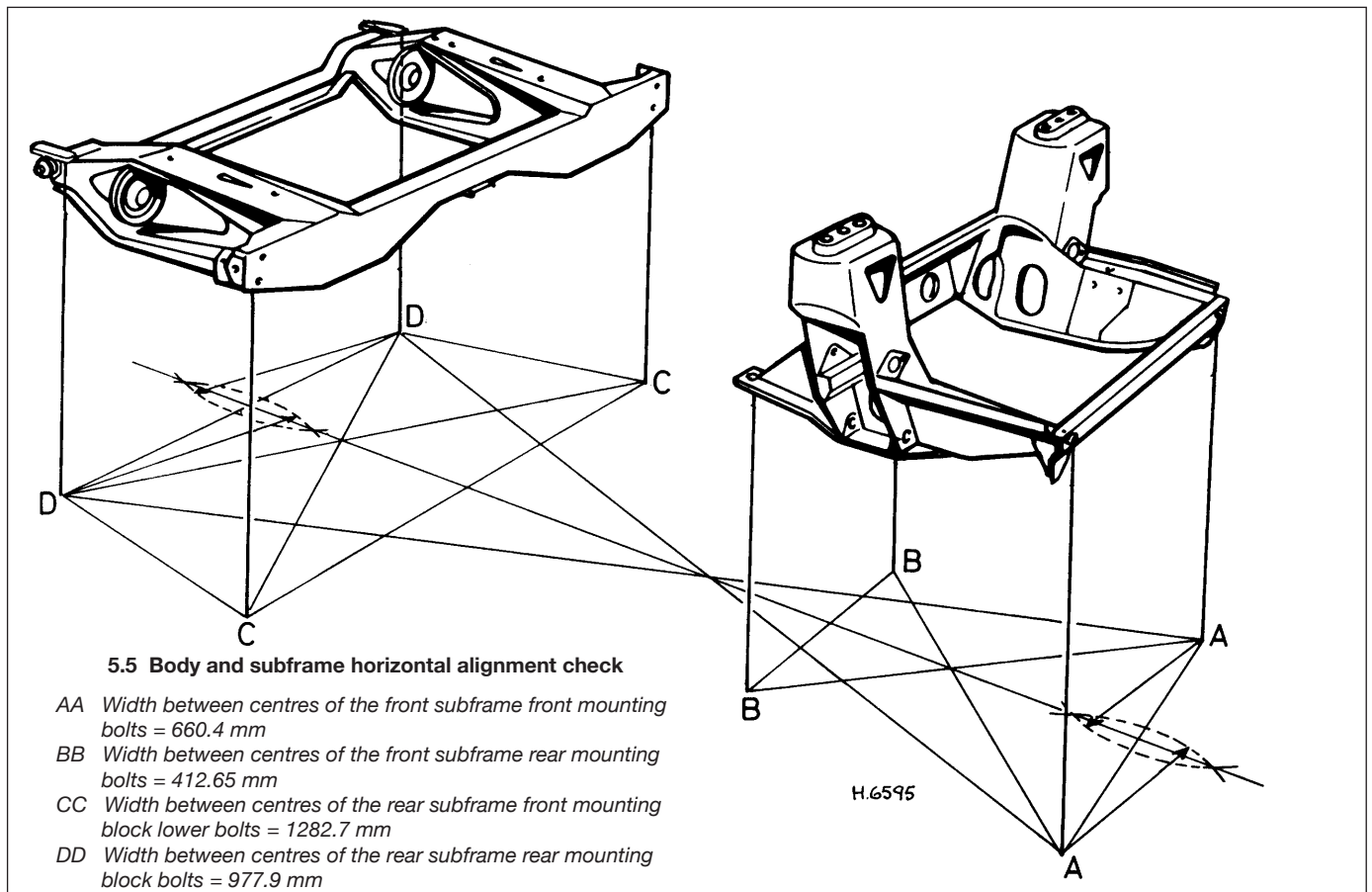

each line. A line drawn on the floor starting at the front and finishing at the rear should be quite straight and pass through the centres of the other lines. Diagonal measurements can also be made as a check for squareness.

**6** On older Minis, rust or corrosion of the vehicle underframe is a common occurrence and, if the corrosion has reached an advanced state, may be grounds for failure of the annual MoT test.

**7** Where serious rust or corrosion has affected a load bearing area, it will be necessary to have this repaired immediately either by fitting a new body section or, in less serious cases, by plating over the affected area. The load bearing areas of the Mini

consist of the subframe, the side sills (inner and outer) and any area of the vehicle structure within 305 mm of a suspension, steering, subframe, or seat belt anchorage point.

**8** Repairs of this nature are best left to a body repair specialist, as any new section or plating that may be necessary must be welded in place to restore the original structural rigidity of the bodyshell. The repair of corrosion to structural areas using fibreglass, body filler, or the retention of new sections with pop rivets, or screws, is not acceptable to legal requirements.

## 6 Front door interior trim panel (Saloon and Estate models) - removal and refitting



### Removal

**1** Undo and remove the two screws and lift off the interior pull handle (see illustration).

**2** Undo and remove the retaining screws and lift away the door lock remote control handle followed by the window regulator handle and surround (see illustrations). On later models, the screw securing the window regulator handle is covered with a trim cap, which must be carefully prised out for access to the screw.



6.1 Remove the interior pull handle retaining screws and handle



6.2a Remove the door lock remote control handle . . .



6.2b . . . and the window regulator handle



**6.3 Ease off the interior lock control surround . . .**

**3** Carefully ease off the interior lock control surround (**see illustration**).

**4** On later models undo and remove the retaining screws and lift away the storage bin.

**5** If the top edge of the trim panel incorporates a trim capping, undo the two screws, then carefully ease the capping away from the door using a wide-bladed screwdriver or flat strip of metal. This will release the three retaining studs behind the capping, allowing the capping to be lifted away. If any of the studs break during removal, extract the broken stud and glue a new one in its place.

**6** Using a wide-bladed screwdriver or flat strip of metal inserted between the trim panel and the door, carefully detach the trim panel clips from the door panel (**see illustration**).

**7** When all the clips are released, the panel can be withdrawn.

**8** If it is wished to gain access to the internal door components, carefully peel off the waterproof covering.

### Refitting

**9** Refitting is the reverse sequence to removal, but ensure that the waterproof covering is in position before refitting the panel. If the panel incorporates a trim capping, refit by placing the capping in position and pushing the studs fully home. Secure with the three retaining screws.

## 7 Doors - removal and refitting



### All models except Van and Pick-up

#### Removal

**1** Refer to Chapter 3 and remove the fresh air vent assembly (if fitted) adjacent to the door pillar.

**2** Gently ease the door sealing rubber from the door pillar around the area where it retains the facia inner trim.

**3** Undo and remove the retaining screws (if fitted), and then carefully fold back the facia inner trim to give access to the door check strap aperture.



**6.6 . . . then detach the panel clips and withdraw the trim panel**

**4** Extract the split pin and clevis pin from the door check strap.

**5** Support the weight of the door on blocks, or engage the help of an assistant. Undo and remove the four nuts and two washer plates, accessible from inside the front wheel arch.

**6** Carefully lift the door assembly, complete with hinges, off the body, noting the position of any alignment shims that may be fitted to the hinges.

### Refitting

**7** Refitting the door is the reverse sequence to removal.

### Van and Pick-up models

#### Removal

**8** Upon inspection it will be seen that each door is held in place by two hinges and a check strap.

**9** To remove a door, first unscrew and remove the two set screws and washers that secure the door check strap coupling bracket which is located on the inside of the door pillars. To gain access it will be necessary to ease back the side trim first.

**10** Open the door carefully and pull out the interior lining of the door.

**11** Undo and remove the cross-head screw and nut from the door side of each of the two hinges.

**12** The door can now be lifted away from the body, leaving the hinges still attached to the body.

### Refitting

**13** Refitting the door is the reverse sequence to removal.

## 8 Door hinge - removal and refitting



### All models except Van and Pick-up

#### Removal

**1** Remove the door as described in Section 7.

**2** The hinges can now be removed from the door by simply undoing the retaining screws and lifting off.

### Refitting

**3** Refitting is the reverse sequence to removal.

### Van and Pick-up models

#### Removal

**4** Refer to Section 7 and remove the door.

**5** Two nuts/bolts hold each hinge to the inside of the front wing. The heads of the nuts/bolts are very difficult to get at because they are surrounded at the top and bottom by the sides of the support brackets. This is particularly applicable to the top hinge, inside bolt.

**6** Using a socket and universal coupling, undo and remove the nuts and bolts and lift away the hinge.

**7** If the head on one of the bolts has become so burred that the spanner will no longer fit and provide a positive grip, very carefully examine a new hinge and decide on the exact position of the old bolt by comparison.

**8** The old bolt can then be carefully drilled out from the outside of the hinge.

### Refitting

**9** Refitting the door hinge is the reverse sequence to removal.

## 9 Front door glass - removal and refitting



### All models except Van and Pick-up

#### Removal

**1** Refer to Section 6, and remove the door interior trim panel.

**2** Carefully ease off the waist rail finisher strips from the top of the door edge, taking care not to damage them as they are lifted away from the clips.

**3** Wind the window approximately half-way down so that the two arms of the regulator mechanism are as near vertical as they can be. With a piece of wood, wedge the window glass at the sill in this position.

**4** Remove the regulator mechanism securing screws (**see illustration**).

**5** Pull the regulator away from the door panel enough to move it forwards so that the rear arm comes out of the window channel. Then move the mechanism back to release the arm from the front channel and lift it away.

**6** Support the glass with one hand, remove the wedge and tilt the forward edge down into the door so that the top rear corner of the glass comes inside the top of the window frame. The glass can then be lifted out.

### Refitting

**7** Refitting is the reverse sequence to removal, bearing in mind the following points:

- a) *Make sure that the window is located snugly in the frame glazing channels before wedging it in the half-way position.*

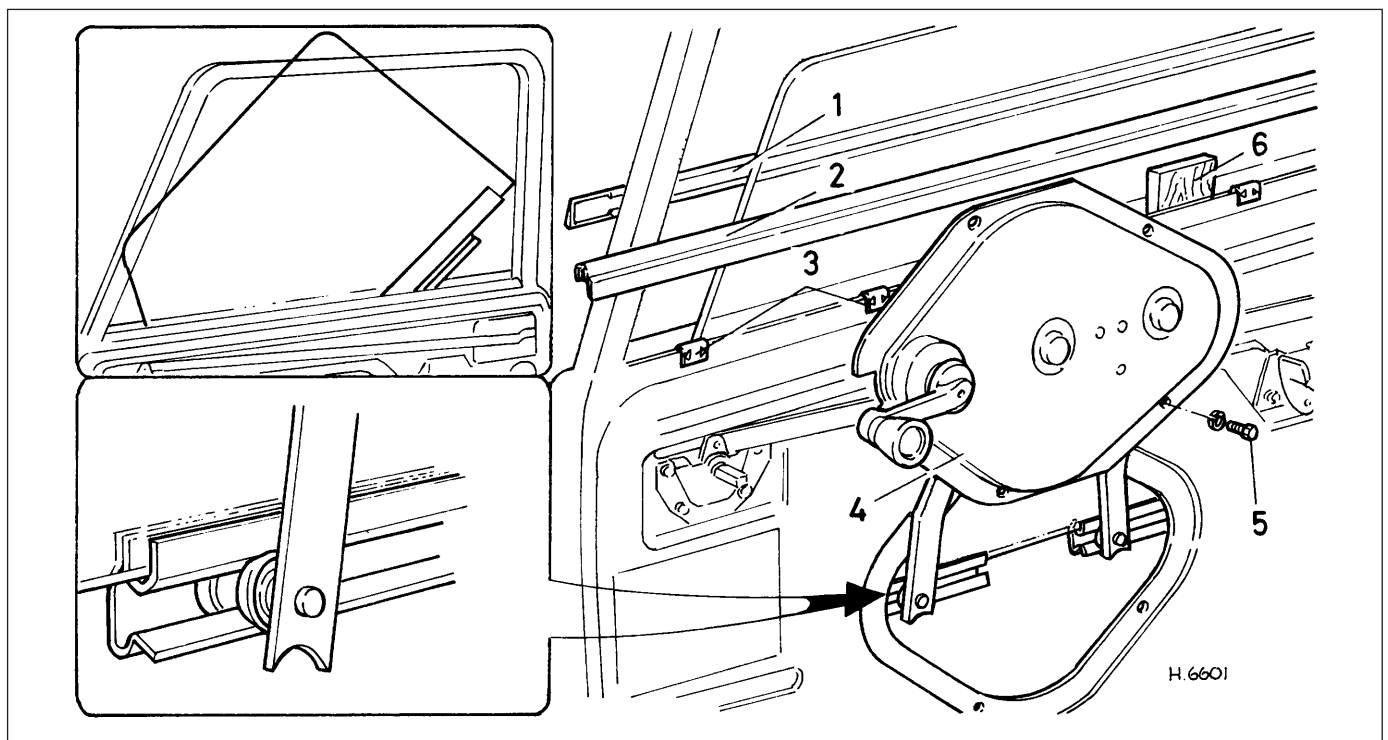

**9.4 Removal of front door glass**

*Inset shows regulator arm and position of door glass ready for removal*

- |                               |                                |                             |
|-------------------------------|--------------------------------|-----------------------------|
| 1 Waist rail finisher (outer) | 3 Securing clips for finishers | 5 Regulator securing screws |
| 2 Waist rail finisher (inner) | 4 Window regulator             | 6 Wedge (to hold glass)     |

b) Check that the waist rail finisher clips are evenly spaced before fitting the finishers back on. With the inner finisher, butt the forward end against the glazing channel rubber seal before fitting the rest.

c) Before securing the regulator mechanism to the door panel, apply a suitable sealer to the edge of the plate. This compensates for any irregularities in the panel which could cause rattles. Ensure that the lip on the front edge of the plate is engaged inside the panel.

**Van and Pick-up models**

**Removal**

**8** Undo and remove the retaining screw, boss and washer securing the catches to the glass. Lift off the catches and sealing rubbers.

**9** Slide the front glass rearwards and then undo and remove the screw securing the lower channel to the door. If the screw is very tight or badly corroded, apply liberal amounts of penetrating oil to the screw and allow it to soak in. Give the screw a sharp tap with a hammer and drift to break the corrosion. It should now be possible to unscrew it.

**10** Move both glasses forward and repeat the above procedure, if necessary, on the other lower channel retaining screw.

**11** Ease the glasses, lower channel, and glass catch strip towards the centre of the car at the bottom, then lift the assembly off the door. The two sliding glasses can then be removed from the lower channel.

**Refitting**

**12** Refitting is the reverse sequence to removal.

**10 Front door lock assembly - removal and refitting**

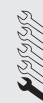

**All models except Van and Pick-up**

**Removal**

**1** Refer to Section 6 and remove the door interior trim panel.

**2** Undo and remove the screws securing the

door inner remote control handle to the door panel (see illustration).

**3** Undo and remove the screws securing the interior lock control to the door panel (see illustration).

**4** Undo and remove the screws securing the door lock to the side of the door (see illustration).

**5** Slide the door lock out of its location in the door and carefully release the two small circlips securing the remote control handle and interior lock operating rods to the door lock assembly.

**6** Lift away the door lock, then withdraw the remote control and interior lock control from the door panel.



**10.2** Remove the door inner remote control handle retaining screws ...



**10.3** ... the interior lock control retaining screws ...





10.4 ... and the door lock retaining screws

**Refitting**

7 Refitting is the reverse sequence to removal, bearing in mind the following points:

- a) Ensure that the small link rod on the lock assembly is engaged with the operating link of the exterior door handle.
- b) If problems are experienced with the operation of the lock, it is likely that the inner remote control handle assembly is incorrectly positioned. If the door fails to lock, loosen the three retaining screws, and move the remote control handle assembly forwards to correct the operation. If the door fails to unlock, move the assembly rearwards.

**Van and Pick-up models**

**Removal**

8 Undo and remove the three screws that secure the lock body to the inner door panel (see illustration).

9 Undo and remove the screw located at the end of the locking handle spindle.

10 Slacken the inner handle clamp screw (where fitted) and slide out the outer handle and escutcheon. Now lift off the lock body.

**Refitting**

11 Refitting is the reverse sequence to removal.

**11 Front door exterior handle (Saloon and Estate models) - removal and refitting**



**Removal**

1 Refer to Section 6 and remove the door interior trim panel.

2 Undo and remove the screws securing the interior lock control to the inner door panel.

3 Undo and remove the screws securing the door lock assembly to the side of the door, and move the lock up at the bottom and away from the door.

4 Undo and remove the screws securing the exterior handle to the door and lift the handle off (see illustration).

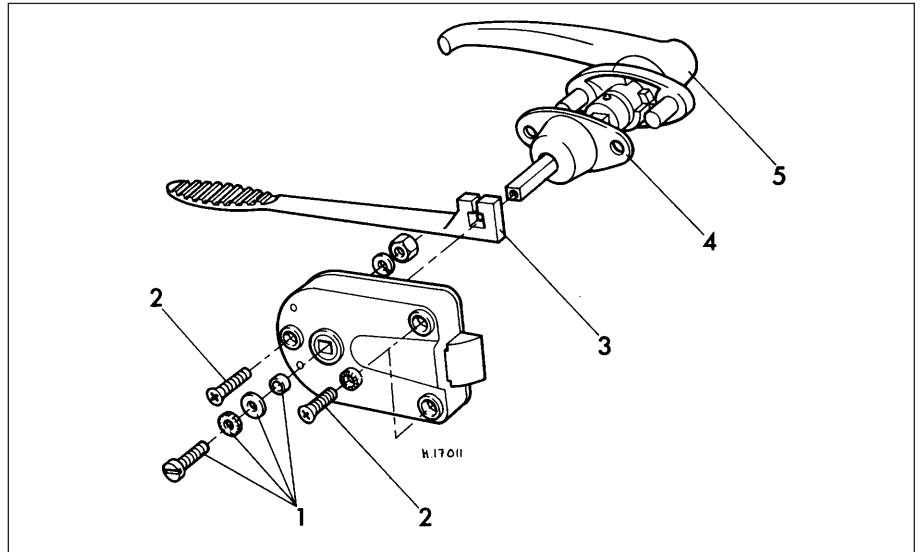

10.8 Exploded view of the door lock and handle assembly fitted to Van and Pick-up models

- 1 Lock handle spindle fixings
- 2 Lock body retaining screws
- 3 Interior handle
- 4 Seal
- 5 Exterior handle

5 With the handle removed, the lock barrel and push button can be withdrawn as follows.

6 Prise off the retaining clip securing the lock barrel to the handle.

7 Insert the key into the lock and withdraw the lock barrel.

8 Undo and remove the screw securing the retaining plate to the exterior handle.

9 Lift off the retaining plate, operating link, washer, and spring. Now withdraw the push button.

**Refitting**

10 Refitting is the reverse sequence to removal. On the earlier type door handle the push button plunger incorporates an adjustable nylon cap over the plunger. The adjustment of this cap is set during manufacture, but if necessary it can be screwed in or out slightly to give 1.0 to 1.5 mm of free play before contacting the door lock release lever (see illustration).

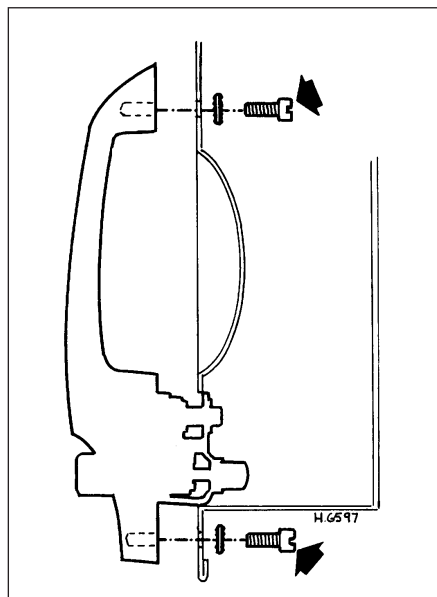

11.4 Exterior door handle securing screws (arrowed) - Saloon and Estate models

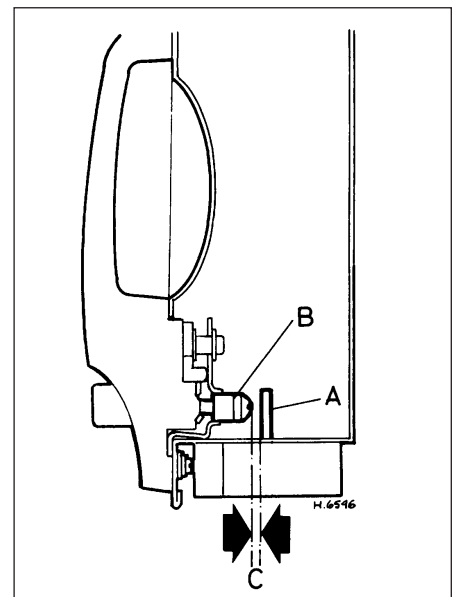

11.10 Door handle push button plunger adjustment

- A Lock release lever
- B Plunger cap
- C = 1.0 to 1.5 mm

## 12 Front door striker plate - removal and refitting



### All models except Van and Pick-up

#### Removal

- 1 Remove the striker plate cover from the body pillar.
- 2 Undo and remove the striker plate retaining screws, lift out the striker lock and remove the striker plate.

#### Refitting

- 3 Refitting is the reverse sequence to removal. Adjust the striker plate so that as the door is closed, the striker lock passes through the door lock without fouling. It should also be possible to push the door in slightly against compression of the sealing rubber when the door is closed.

### Van and Pick-up models

#### Removal

- 4 To remove the striker on these models, simply undo and remove the retaining screws and lift off.

#### Refitting

- 5 When refitting the striker plate, adjust it so that the door sealing rubber is just compressed and the door is flush with the adjoining bodywork when closed.

## 13 Bonnet - removal and refitting



#### Removal

- 1 Open the bonnet and support on its stay.
- 2 With a pencil, mark the outline of the hinge on the bonnet to assist correct refitting.
- 3 An assistant should now take the weight of the bonnet. Undo and remove the bonnet-to-hinge retaining nuts, spring and plain washers at both hinges (see illustration). Carefully lift away the bonnet over the front of the car.

#### Refitting

- 4 Refitting is the reverse sequence to removal. Alignment in the body may be made by leaving the securing nuts slightly loose and repositioning by trial and error.

## 14 Bonnet lock release cable - removal and refitting



#### Removal

- 1 From inside the car, slacken the retaining nut, and release the cable and handle assembly from the bracket under the fascia.

- 2 In the engine compartment, remove the ignition splash shield, then undo the two bolts securing the bonnet lock to the front panel.

- 3 Disconnect the return spring and the release cable from the bonnet lock, and remove the lock.

- 4 Undo the bolt and move the relay located at the rear of the right-hand inner wing, for access to the cable-to-bulkhead grommet.

- 5 Release the cable from the cable clip, push the cable grommet through the bulkhead, and withdraw the cable from inside the car.

#### Refitting

- 6 Refitting is the reverse sequence to removal, but adjust the bonnet lock alignment before finally tightening the two lock retaining bolts.

## 15 Bonnet lock - removal and refitting



#### Removal

- 1 Open the bonnet and support it on its stay.
- 2 On models having an ignition splash shield attached to the body front panel, undo and remove the retaining screws and withdraw the shield.

- 3 Detach the slider catch return spring.
- 4 Undo and remove the two screws securing the lock assembly to the front panel and lift off the lock and guide plate.

#### Refitting

- 5 Refitting is the reverse sequence to removal.

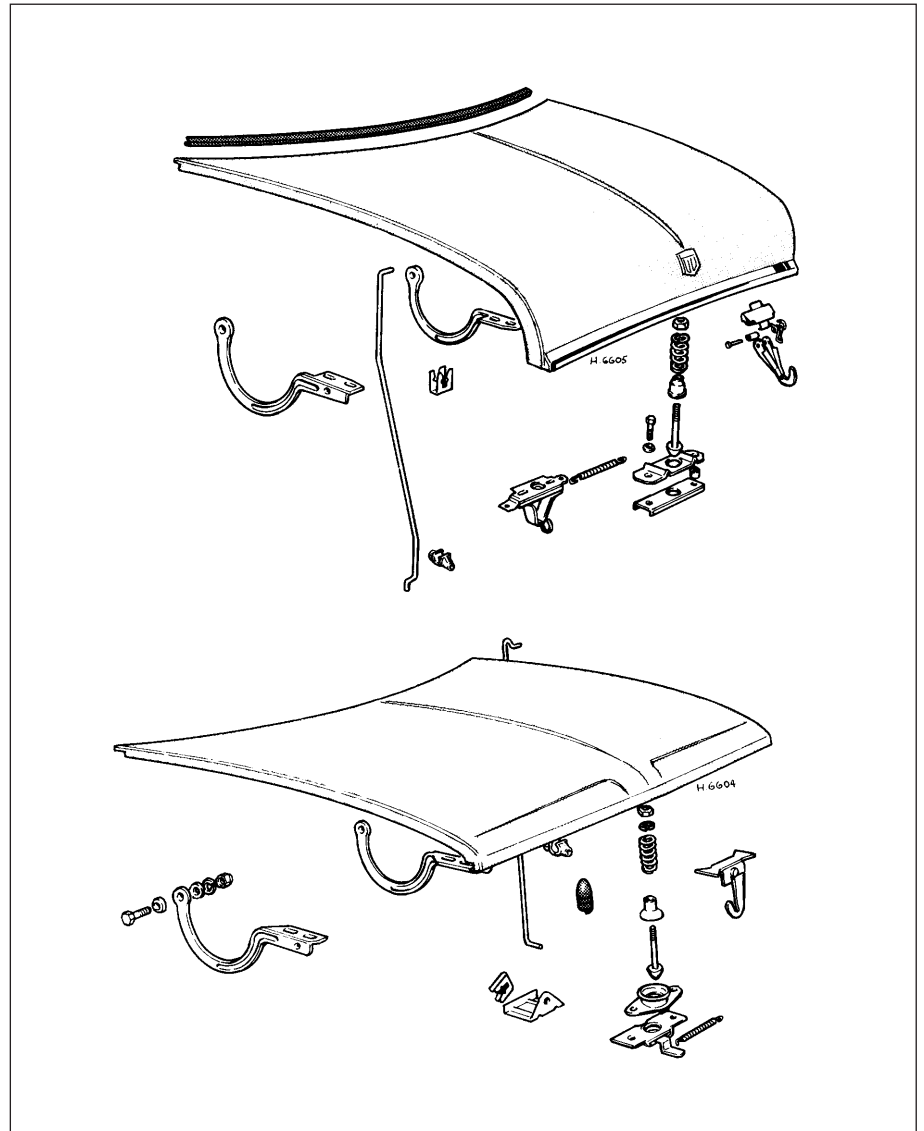

13.3 Bonnet hinge and lock assemblies

**16 Boot lid - removal and refitting****Removal**

- 1 Open the boot lid and disconnect the number plate light electrical leads from their connectors in the boot compartment wiring harness.
- 2 Support the boot lid and undo and remove the screws securing the two stays to the sides of the boot lid.
- 3 Undo and remove the nuts, spring and plain washers securing the hinges to the boot lid and lift off the boot lid (see illustration).

**Refitting**

- 4 Refitting is the reverse sequence to removal.

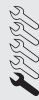
**17 Boot lid lock - removal and refitting****Removal**

- 1 Open the boot lid, undo and remove the retaining screws, and lift off the lock assembly.
- 2 To remove the lock handle, undo and remove the two nuts and washers and lift off the handle and joint washer.
- 3 If it is wished to remove the lock barrel from the handle, extract the spring clip and slide off the flat and wavy washers from the end of the handle.
- 4 Take out the small lock barrel retaining pin and then slide out the barrel. Recover the locking pin from the end of the handle.

**Refitting**

- 5 Reassembly and refitting of the lock is the reverse sequence to removal. When reassembling the lock barrel, position the small retaining pin in the slot of the locking pin before refitting.

**18 Rear doors (Estate and Van models) - removal and refitting****Removal**

- 1 Open both doors and disconnect the door support stays by undoing the nut, washer and bolt at the end of each stay.
- 2 Preferably have an assistant hold the door, or place a support under it, and then bend down the tab washer on each door hinge.
- 3 Undo and remove the nut, tab washer, hinge centre bolt, and the spherical bush from each of the door hinges in turn.

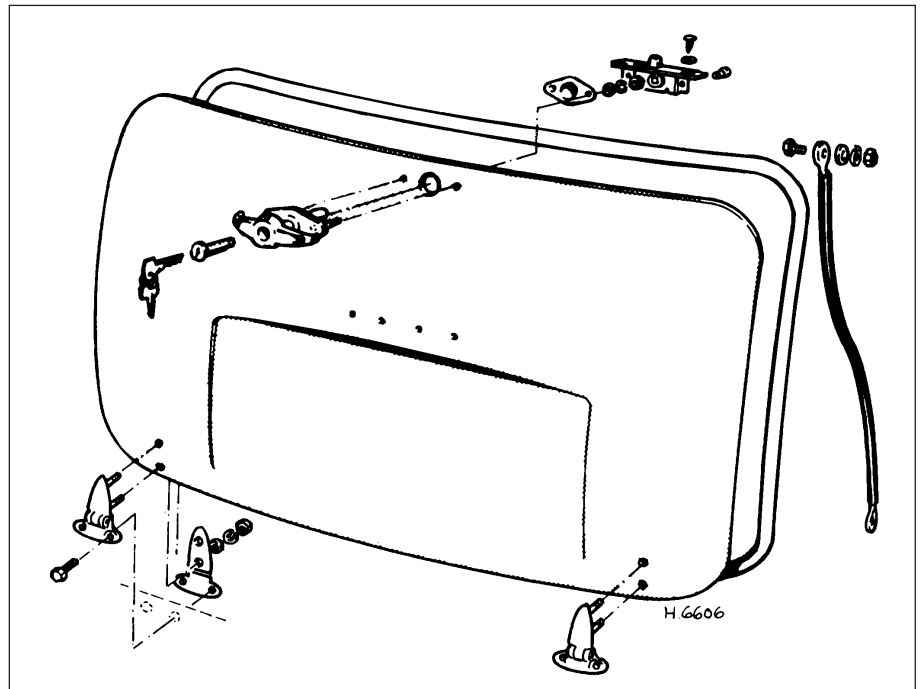
**16.3 Boot lid hinge and lock assemblies****Refitting**

- 4 Refitting is the reverse sequence to removal.

**19 Rear door lock (Estate and Van models) - removal and refitting****Removal**

- 1 Undo and remove the screws securing the lock to the door.
- 2 Disengage the lock assembly from the handle, lift it up to release the lower stay from its guide, lower it to release the upper stay, and then withdraw the complete assembly.
- 3 Slacken the nuts securing the stays to the lock and then unscrew the stays.
- 4 To remove the door handle, release the door seal retaining clips from the hole in the door panel.
- 5 Undo and remove the nuts and washers securing the door handle to the door. Lift off the handle and recover the joint washer.
- 6 To remove the lock barrel, first remove the retaining circlip and slide off the cover, spring washer and brass washers.
- 7 Withdraw the handle yoke, extract the lock barrel retaining pin, and remove the lock barrel and locking pin.

**Refitting**

- 8 Reassembly and refitting is the reverse sequence to removal. When refitting the stays note that the cranked stay is refitted to the top with the crank to the right.

**20 Tailgate (Pick-up models) - removal and refitting****Removal**

- 1 Undo and remove the number plate light cover retaining screw and lift off the cover and lens.
- 2 Detach the electrical leads from the number plate light bulb holders and withdraw the leads from the tailgate.
- 3 Support the tailgate in the open position, then undo and remove the tailgate stays securing screws.
- 4 Undo and remove the screws securing the tailgate hinges to the tailgate and carefully lift away the tailgate.

**Refitting**

- 5 Refitting is the reverse sequence to removal.

**21 Windscreen - removal and refitting****Removal**

- 1 Remove the wiper arms from their spindles by using a screwdriver to ease them up, then lift off.
- 2 If a self-adhesive interior mirror is fitted to the windscreen, remove it by gently warming the mirror base and the area of screen around it. Use a hair dryer or rag soaked in warm water as a heat source.

**3** Using a small screwdriver, carefully ease up one end of the finishing strip from its groove in the windscreen sealing rubber and then pull the entire length of the strip out of the rubber.

**4** If an undamaged windscreen is being removed, from inside the car firmly push the screen outwards, starting at one of the top corners. Carefully remove the complete windscreen from the sealing rubber and lift it off the car. Withdraw the sealing rubber from the windscreen aperture in the body.

**5** If a shattered windscreen is being removed, lay some old blankets or sheets over the bonnet and in the car interior, making sure that the demister vents are well covered. Break the remaining glass onto the blankets or sheets, and then withdraw the sealing rubber from the windscreen aperture. Discard the shattered glass and clean up any fragments using a vacuum cleaner.



**When cleaning up after a shattered windscreen, operate the heater in all positions with the fan motor running to dislodge any trapped glass, but watch out for flying fragments which may be blown out of the ducting.**

### Refitting

**6** To fit the windscreen, first inspect the sealing rubber for hardness or deterioration and renew if necessary. It is advisable to renew the sealing rubber as a matter of course when fitting a new windscreen.

**7** Position the sealing rubber over the windscreen, and then insert a length of string, around the circumference of the rubber, ensuring that it seats into the body flange groove of the rubber. Position the string so that the two ends protrude by at least 300 mm at the bottom centre of the screen.

**8** Mix a concentrated soap and water solution and apply it liberally to the flange of the windscreen aperture.

**9** Place the windscreen and rubber seal in position on the car, and engage the help of an assistant to apply firm pressure to the outside of the screen. From inside the car use the string to pull the rubber lip over the body flange, working slowly around the screen until the string has been fully withdrawn.

**10** Starting at the top centre of the rubber seal, use a wide-bladed screwdriver to spread the lips of the seal, while at the same time pressing the finishing strip into place. Work around the entire circumference of the windscreen in this way.

**11** With the screen in position and the finishing strip fitted, the wiper arms can now be refitted to their spindles, and the mirror (where fitted) re-secured using a suitable adhesive.

### 22 Rear window (Saloon and Pick-up models) - removal and refitting



The removal and refitting procedure for the rear window or its sealing rubber is the same as described in Section 21 for the windscreen. On later models, it will also be necessary to disconnect the electrical supply and earth leads to the heated rear window element before removal.

### 23 Rear door window (Estate and Van models) - removal and refitting



The removal and refitting procedure for the rear door window or its sealing rubber is the same as described in Section 21 for the windscreen. Note, however, that the sealing rubber does not incorporate a finishing strip.

### 24 Rear quarterlight glass (Saloon models) - removal and refitting



#### Hinged type

##### Removal

**1** Open the window and then undo and remove the screws securing the catch to the body.

**2** With the window supported, undo and remove the screws securing the hinge(s) to the body pillar.

**3** Lift away the window, and if required undo and remove the retaining screw and window glass surround.

##### Refitting

**4** Refitting is the reverse sequence to removal.

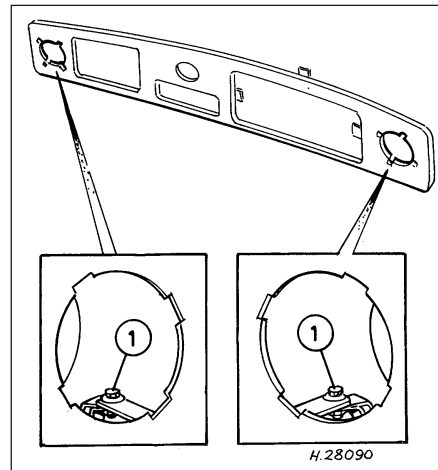

**26.6 Wooden fascia attachment points**

**1** Inset shows mounting bracket locations accessible through fresh air vent apertures

### Fixed type

**5** Removal and refitting of the fixed type window follows the same procedure as described for the windscreen in Section 21. Note, however, that the sealing rubber does not incorporate a finishing strip.

### 25 Rear side screen window (Estate models) - removal and refitting



#### Removal

**1** Carefully remove the trim panel from above the windows.

**2** Undo and remove the screw securing the fixed window locking peg and withdraw the peg.

**3** Undo and remove the screws securing the front, upper, and rear glazing channels and lift out the front and rear channels.

**4** Slide the windows toward the front of the car and then pull down the rear of the upper channel to release it from the window frame.

**5** Now slide the windows and upper channel rearwards to release the front of the upper channel, and then carefully remove the channel and windows.

#### Refitting

**6** Refitting is the reverse sequence to removal.

### 26 Wooden fascia - removal and refitting



#### Removal

**1** Disconnect the battery negative lead.

**2** Open the doors, and carefully release the door seal weatherstrip from the area near the ends of the fascia.

**3** Remove the complete steering column assembly as described in Chapter 10.

**4** Remove the fresh air vent assemblies from both sides of the fascia as described in Chapter 3.

**5** Remove the radio as described in Chapter 12.

**6** Working through the fresh air vent apertures, slacken the two bolts, one each side, securing the fascia mounting brackets (see illustration).

**7** Release the fascia and withdraw it forward from its location.

**8** Disconnect the wiring to the glovebox light, clock and instruments, then remove the fascia from the car.

**9** The glovebox can be removed, if desired, by undoing the screws securing the lid hinges and the glovebox liner, and lifting these components away (see illustration).

**10** The instrument panel can be removed by undoing the 12 screws securing the panel to the rear of the fascia and lifting away, complete with instruments. Removal of the instruments from the panel is as described in Chapter 12.



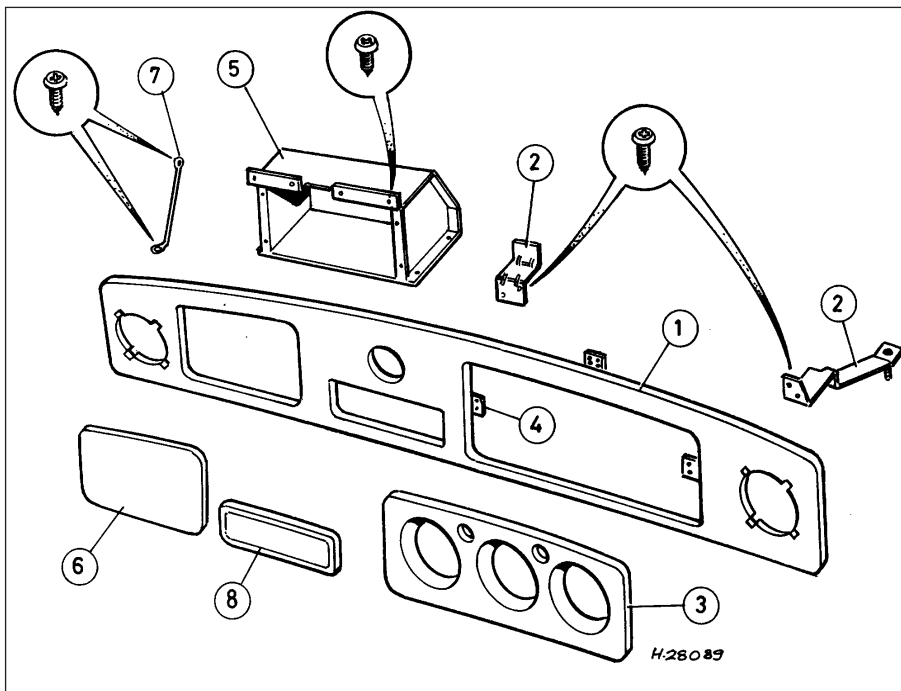

26.9 Wooden fascia components

- |   |                         |   |                                   |   |                                     |
|---|-------------------------|---|-----------------------------------|---|-------------------------------------|
| 1 | Facia panel             | 4 | Instrument panel retaining plates | 7 | Glove box lid strap                 |
| 2 | Facia mounting brackets | 5 | Glove box liner                   | 8 | Radio blanking plate (where fitted) |
| 3 | Instrument panel        | 6 | Glove box lid                     |   |                                     |

11 To remove the clock, simply undo the clamping bracket nut, and slide the clock out of the front of the facia.

**Refitting**

12 Refitting is the reverse sequence to removal.

**27 Facia top rail cover - removal and refitting**



**Removal**

**Note:** When removing the facia top rail on models with a wooden facia, the facia must be removed first as described in Section 26.

1 Remove the fresh air vent assemblies from both sides of the facia as described in Chapter 3.

2 Release the door seal weatherstrip from the body pillar sufficiently to clear the top rail cover.

3 Withdraw the left-hand facia inner trim panel.

4 Undo and remove the four nuts securing the top rail cover, lift the front of the cover upwards to release the four studs, and then withdraw the cover from the car.

**Refitting**

5 Refitting is the reverse sequence to removal.

**28 Centre console - removal and refitting**

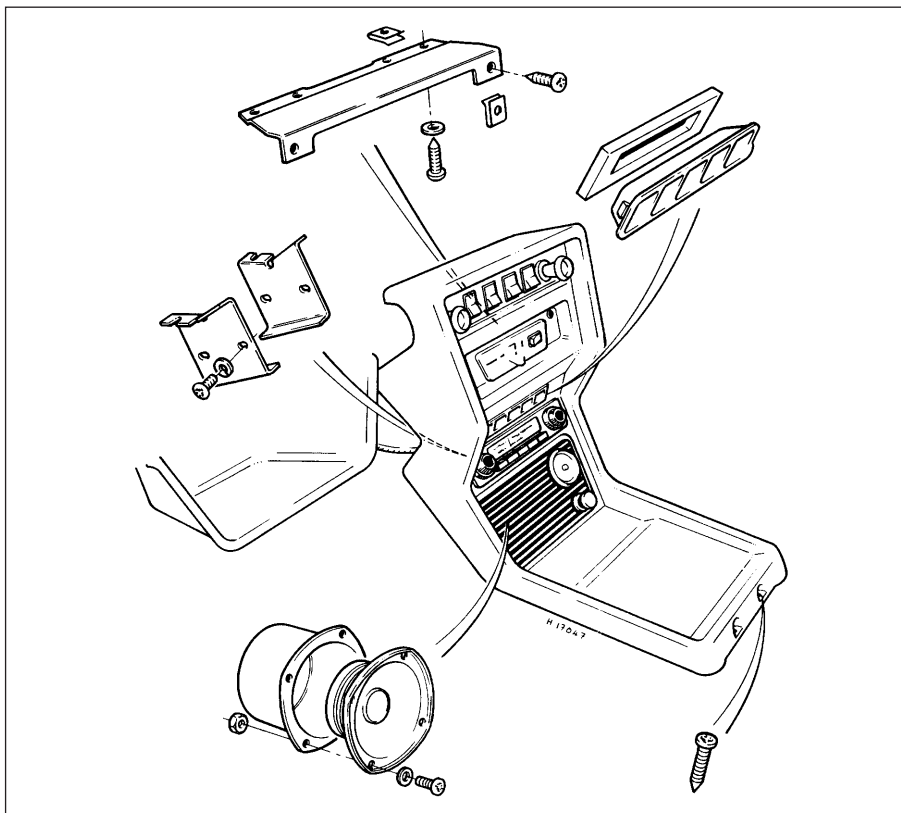

28.2 Centre console components and attachments

**Removal**

1 Disconnect the battery negative lead.

2 Undo and remove the centre console retaining screws (see illustration).

3 Carefully ease off the radio knobs and finishers, and then undo and remove the radio securing wing nuts.

4 Engage fourth gear, while at the same time moving the console rearwards. Undo and remove the radio retaining screws and ease the radio clear of the console.

5 Disconnect the wiring from the clock and cigarette lighter, and detach the speaker plug from the radio.

6 Release the gear lever grommet then remove the centre console from the car.

7 With the console removed, release the clamp and lift out the cloth. Unscrew the cigarette lighter body and withdraw it. Unclip and remove the speaker grille, then lift out the speaker after undoing the retaining screws.

**Refitting**

8 Refitting the components to the console and the console to the car is the reverse sequence to removal.

**29 Front grille - removal and refitting**



**All models except Clubman and 1275 GT**

**Removal**

1 Undo and remove the self-tapping screws securing the edge trim to each side of the grille and lift off the trim (**see illustration**).

2 Undo and remove the remaining screws securing the centre panel of the grille and withdraw the panel.

**Refitting**

3 Refitting is the reverse sequence to removal.

**Clubman and 1275 GT models**

**Removal**

4 Undo and remove the self-tapping screws securing the grille panel and the headlight extension panels.

5 Lift off the extension panels, disengage the lugs on the lower edge of the grille from the grommets in the lower body panel, and lift off the grille.

**Refitting**

6 Refitting is the reverse sequence to removal.

**30 Bodywork seam trim strips - general information**



1 The welded seams on the exterior of the Mini bodywork are covered by protective metal and push-fit trim strips which are either chromium plated or sprayed to match the exterior colour scheme. Additionally, a chrome, black, or body-coloured trim strip is used to cover the side sill seams and, on models without flared wheel arch extensions, the wheel arch edges. On most models, this is a one piece plastic moulding running the full length of the car.

2 The side seam trim strips are removed by carefully prising up with a screwdriver and lifting off.

3 To refit the strips, ensure that the small retaining clips are in sound condition and simply push the trim into place, giving it a firm push with the palm of your hand to ensure that it is fully home.

4 The wheel arch and side sill plastic moulding is removed after first drilling out the

pop rivet that retains each end of the trim to the wheel arch.

5 Before fitting a new trim, heat it slightly in a warm oven until it is pliable and then carefully position it over the wheel arch edges and side sill seams. Secure each end with a pop rivet or self tapping screw.

**31 Front and rear bumpers - removal and refitting**



The layout of the bumpers and their method of attachment varies considerably according to model type and year of manufacture. The location and type of retaining nuts, bolts or screws will be obvious after a visual inspection, and no problems should be encountered (**see illustration**). On models with a full width wrap-around bumper, it is helpful to engage the aid of an assistant to support the bumper, thus ensuring that the paintwork is not scratched as it is removed.

**32 Sunroof components - general information**

The sunroof is a complex piece of equipment, consisting of a large number of components. Adjustment and/or repair of the sunroof is outside the scope of this manual, and it is recommended that work of this nature should be entrusted to your Rover dealer.

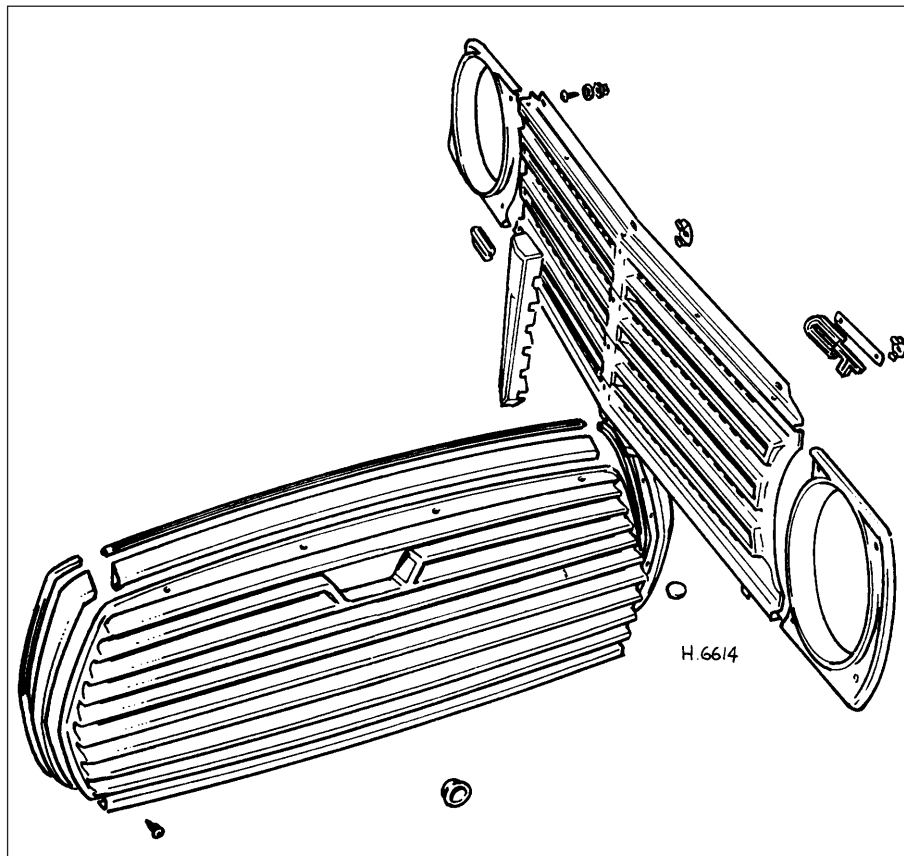

29.1 Front grille panels and attachments

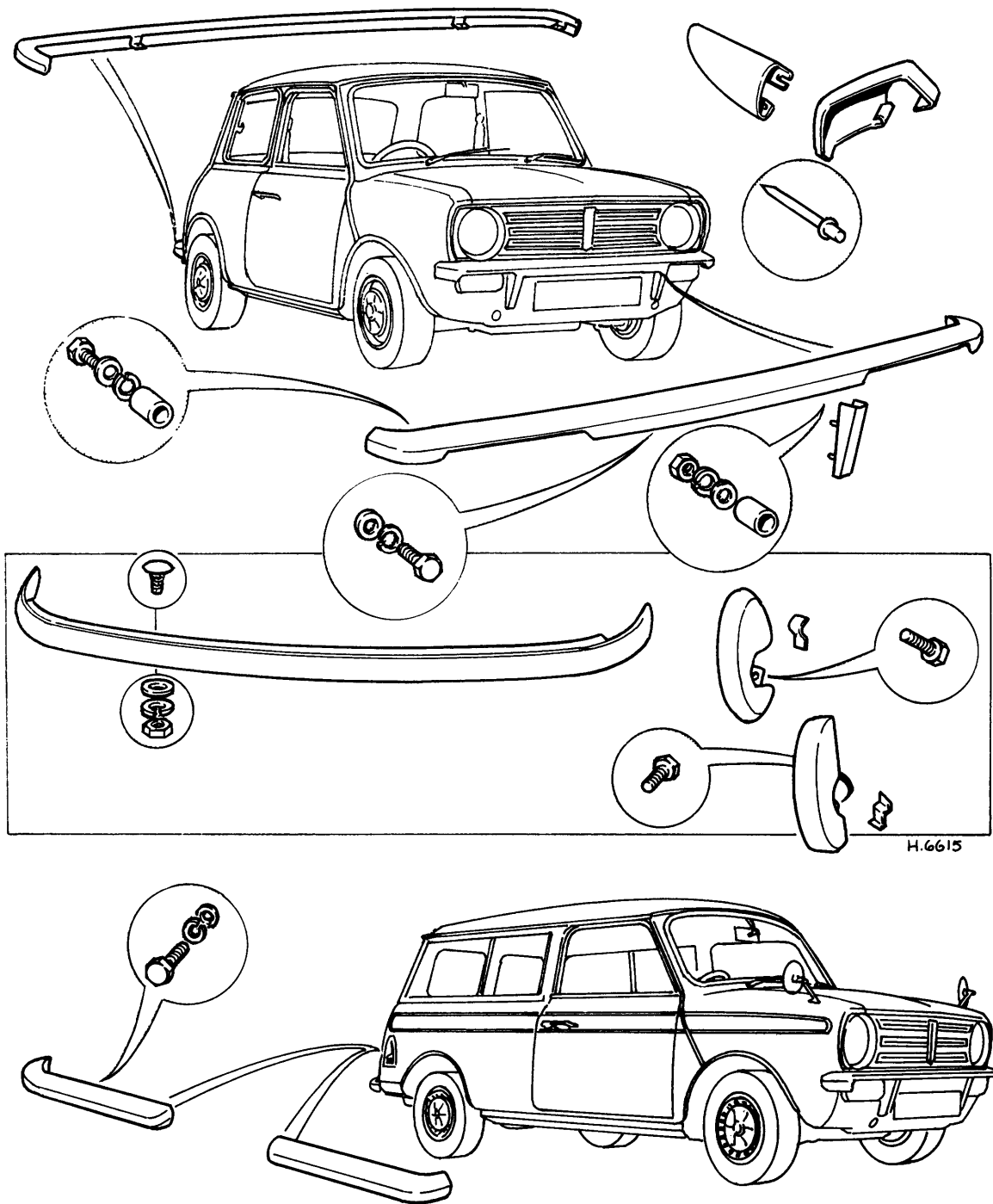

31.1 Front and rear bumpers and attachments - Clubman models





# Chapter 12

## Body electrical system

### Contents

Anti-theft alarm system components - removal and refitting	19	Radio - removal and refitting	18
Bulbs (exterior lights) - renewal	5	Speedometer cable - removal and refitting	17
Bulbs (interior lights) - renewal	6	Switches - removal and refitting	4
Dim-dip lighting system components - removal and refitting	8	Windscreen washer fluid level check	.See "Weekly Checks"
Electrical fault finding - general information	2	Windscreen washer pump - removal and refitting	14
Fuses and relays - general information	3	Windscreen wiper arms - removal and refitting	10
General information and precautions	1	Windscreen wiper motor - dismantling and reassembly	12
Headlight beam alignment - checking and adjusting	7	Windscreen wiper motor - removal and refitting	11
Horn - removal, refitting and adjustment	9	Windscreen wiper wheelbox - removal and refitting	13
Instrument panel - dismantling and reassembly	16	Wiper blade check	.See "Weekly Checks"
Instrument panel - removal and refitting	15		

### Degrees of difficulty

<b>Easy</b> , suitable for novice with little experience 	<b>Fairly easy</b> , suitable for beginner with some experience 	<b>Fairly difficult</b> , suitable for competent DIY mechanic 	<b>Difficult</b> , suitable for experienced DIY mechanic 	<b>Very difficult</b> , suitable for expert DIY or professional 
---	--	--	---	--

### Specifications

#### General

System type ..... 12-volt negative earth

#### Main fuses (two-fuse fuse block)

Fuse connecting	Rating (amp)
1 and 2	35
3 and 4	35

#### Circuits protected

Interior light, horn and auxiliary units which operate with the ignition switched on or off  
 Direction indicators, windscreen wiper motor, heater blower, stop lights and auxiliary units which operate only when the ignition is switched on

**Note:** The fitting of additional accessories which are required to operate independently of the ignition circuit should be connected to the "2" terminal; accessories which are required to operate only when the ignition is switched on should be connected to the "4" terminal.

#### Line fuses (two-fuse fuse block)

Rating (amp)
8
35

#### Circuits protected

Side and tail lights  
 Hazard flasher

#### Main fuses (four-fuse fuse block - early models)

Fuse connecting	Rating (amp)
1 and 2	35
3 and 4	25
5 and 6	25
7 and 8	15

#### Circuits protected

Stop lights, reversing lights, direction indicators, heated rear window. These systems will only operate with the ignition switch at position II  
 Horn, headlight flasher, brake failure circuit. These systems operate independently of the ignition switch  
 Heater blower motor, windscreen wipers/ washers, radio. These systems will operate with the ignition switch at position I or II  
 Side and tail lights, instrument panel lights

**Note:** The fitting of additional accessories which are required to operate independently of the ignition circuit should be connected to the "4" terminal.

#### Line fuses (four-fuse fuse block - early models)

Rating (amp)
15
-

#### Circuits protected

Hazard flashers, interior light  
 Radio (rating to be as specified by the manufacturer)



## 12•2 Body electrical system

### Main fuses (four-fuse fuse block - later models)

Fuse connecting	Rating (amp)
1 and 2	35
3 and 4	25
5 and 6	25
7 and 8	15

#### Circuits protected

Stop lights, reversing lights, direction indicator relay, heated rear window, headlight dim-dip relay. These systems will only operate with the ignition switch at position II  
Horn, headlight flasher, brake failure circuit, radio memory. These systems operate independently of the ignition switch  
Heater blower motor, windscreen wipers/ washers, instruments. These systems will operate with the ignition switch at position I or II  
Left-hand side and tail lights, instrument panel lights, headlight dim-dip relay

**Note:** The fitting of additional accessories which are required to operate independently of the ignition circuit should be connected to the "4" terminal

### Line fuses (four-fuse fuse block - later models)

Rating (amp)
15
10
15
10

#### Circuits protected

Right-hand side and tail lights  
Direction indicators/hazard flashers, interior light  
Dim-dip lighting  
Rear fog light

### Fuses (twenty four-fuse fuse block)

Fuse number	Rating (amp)
1	15
2	15
3	15
4	15
5	15
6	15
7	20
8	10
9	10
10	10
11	10
12	10
13	10
14	10
15	10
16	10
17	10
18	10
19	20
20	15
21	10
22	20
23	Not used
24	10

#### Circuits protected

Heated rear window  
Reversing lights, stop lights, headlight dim/dip\*, direction indicator relay  
Auxiliary cooling fan  
Headlight dim/dip\*  
Heater blower motor, sunroof motor\*  
Wipers/ washers  
Headlight flasher, horn, anti-theft alarm\*  
Tachometer\*, engine management ECU\*, fuel pump relay\*, anti-theft alarm\*  
Radio/cassette, cooling fan relay, automatic gear selector light\*  
Radio memory\*, interior light, direction indicators, hazard flasher, anti-theft alarm LED\* brake test circuit\*  
Fuel pump\*  
Starter signal  
Left-hand, side and tail lights  
Right-hand, side and tail lights, instrument illumination  
Left-hand headlight main beam  
Right-hand headlight main beam, main beam warning light  
Left-hand headlight dip beam  
Right-hand headlight dip beam  
Not used  
Not used  
Not used  
Not used  
Rear fog light

\* depending on model

### Bulbs

Headlights, LHD (except Europe - dip right)	50/40	415
Headlights, Europe (except France - dip vertical)	45/40	410
Headlights, France - dip vertical	45/40	411
Sealed beam headlight units:		
Sealed beam with sidelights, dip left (UK only)	60/45	104
Sealed beam without sidelight, dip left (not UK)	60/54	101
Auxiliary driving lights	55	453
Sidelights (bayonet type)	5	989
Sidelights (capless type)	5	501
Sidelights and front direction indicators	21/5	380
Direction indicators - front	21	382
Direction indicators - rear	21	382
Direction indicator side repeaters	5	501
Number plate light (Saloon)	6	254
Number plate light (Estate, Van and Pick-up)	5	989

#### Wattage

#### Type

Bulbs (continued)	Wattage	Type
Rear foglight .....	21	382
Panel and warning lights .....	2.2	987
Stop/tail lights .....	21/5	380
Reversing lights .....	21	382
Interior light (early models) .....	6	254
Interior light (later models) .....	10	245
Glovebox light .....	10	245
Footwell light .....	5	239
Illuminated switches .....	0.75	284

### Windscreen wiper motor

Brush spring pressure .....	140 to 200 g
Minimum brush length .....	4.8 mm
Armature endfloat .....	0.05 to 0.02 mm
Maximum pull to move rack in guide tubes .....	2.7 kg

## 1 General information and precautions

### General information

The electrical system is of 12-volt negative earth type. Power for the lights and all electrical accessories is supplied by a lead/acid battery which is charged by the dynamo or alternator.

This chapter covers repair and service procedures for the various electrical components and systems generally not associated with the engine. Information on the battery, ignition system, dynamo, alternator and starter motor can be found in the relevant Parts of Chapter 5.

### Precautions



**Warning:** Before carrying out any work on the electrical system, read through the precautions given in "Safety first!" at the beginning of this manual and in Chapter 5.

**Caution:** Prior to working on any component in the electrical system, the battery negative lead should first be disconnected, to prevent the possibility of electrical short-circuits and/or fires. If a radio/cassette player with anti-theft security code is fitted, or if the vehicle is equipped with anti-theft alarm system, refer to the information given in the reference sections of this manual before disconnecting the battery.

## 2 Electrical fault finding - general information



**Note:** Refer to the precautions given in "Safety first!" and in Section 1 of this Chapter before starting work. The following tests relate to testing of the main electrical circuits, and should not be used to test delicate electronic circuits, particularly where an electronic control unit is used.

### General

**1** A typical electrical circuit consists of an electrical component, any switches, relays, motors, fuses, fusible links or circuit breakers related to that component, and the wiring and connectors which link the component to both the battery and the chassis. To help to pinpoint a problem in an electrical circuit, wiring diagrams are included at the end of this manual.

**2** Before attempting to diagnose an electrical fault, first study the appropriate wiring diagram, to obtain a complete understanding of the components included in the particular circuit concerned. The possible sources of a fault can be narrowed down by noting if other components related to the circuit are operating properly. If several components or circuits fail at one time, the problem is likely to be related to a shared fuse or earth connection.

**3** Electrical problems usually stem from simple causes, such as loose or corroded connections, a faulty earth connection, a blown fuse, a melted fusible link, or a faulty relay. Visually inspect the condition of all fuses, wires and connections in a problem circuit before testing the components. Use the wiring diagrams to determine which terminal connections will need to be checked in order to pinpoint the trouble-spot.

**4** The basic tools required for electrical fault-finding include a circuit tester or voltmeter (a 12-volt bulb with a set of test leads can also be used for certain tests); an ohmmeter (to measure resistance and check for continuity); a battery and set of test leads; and a jumper wire, preferably with a circuit breaker or fuse incorporated, which can be used to bypass suspect wires or electrical components. Before attempting to locate a problem with test instruments, use the wiring diagram to determine where to make the connections.

**5** To find the source of an intermittent wiring fault (usually due to a poor or dirty connection, or damaged wiring insulation), a "wiggle" test can be performed on the wiring. This involves wiggling the wiring by hand to see if the fault occurs as the wiring is moved. It should be possible to narrow down the

source of the fault to a particular section of wiring. This method of testing can be used in conjunction with any of the tests described in the following sub-Sections.

**6** Apart from problems due to poor connections, two basic types of fault can occur in an electrical circuit - open-circuit, or short-circuit.

**7** Open-circuit faults are caused by a break somewhere in the circuit, which prevents current from flowing. An open-circuit fault will prevent a component from working.

**8** Short-circuit faults are caused by a "short" somewhere in the circuit, which allows the current flowing in the circuit to "escape" along an alternative route, usually to earth. Short-circuit faults are normally caused by a breakdown in wiring insulation, which allows a feed wire to touch either another wire, or an earthed component such as the bodyshell. A short-circuit fault will normally cause the relevant circuit fuse to blow.

### Finding an open-circuit

**9** To check for an open-circuit, connect one lead of a circuit tester or the negative lead of a voltmeter either to the battery negative terminal or to a known good earth.

**10** Connect the other lead to a connector in the circuit being tested, preferably nearest to the battery or fuse. At this point, battery voltage should be present, unless the lead from the battery or the fuse itself is faulty (bearing in mind that some circuits are live only when the ignition switch is moved to a particular position).

**11** Switch on the circuit, then connect the tester lead to the connector nearest the circuit switch on the component side.

**12** If voltage is present (indicated either by the tester bulb lighting or a voltmeter reading, as applicable), this means that the section of the circuit between the relevant connector and the switch is problem-free.

**13** Continue to check the remainder of the circuit in the same fashion.

**14** When a point is reached at which no voltage is present, the problem must lie between that point and the previous test point with voltage. Most problems can be traced to a broken, corroded or loose connection.

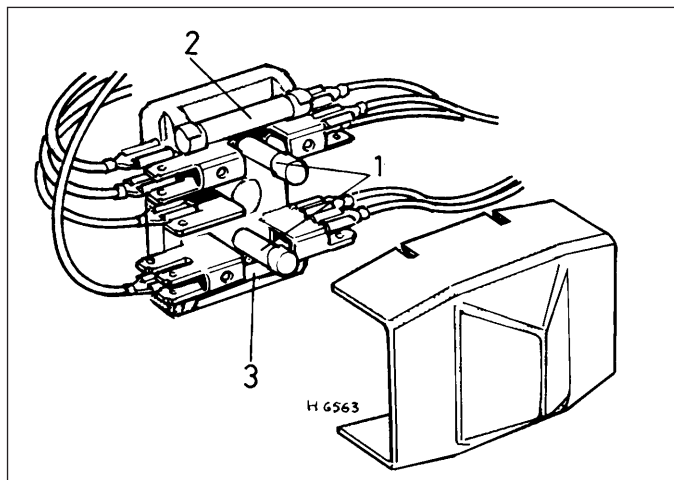

3.1a Two-fuse type fuse block details

- 1 Spare fuses      2 35 amp fuse      3 35 amp fuse

**Finding a short-circuit**

**15** To check for a short-circuit, first disconnect the load(s) from the circuit (loads are the components which draw current from a circuit, such as bulbs, motors, heating elements, etc).

**16** Remove the relevant fuse from the circuit, and connect a circuit tester or voltmeter to the fuse connections.

**17** Switch on the circuit, bearing in mind that some circuits are live only when the ignition switch is moved to a particular position.

**18** If voltage is present (indicated either by the tester bulb lighting or a voltmeter reading, as applicable), this means that there is a short-circuit.

**19** If no voltage is present during this test, but the fuse still blows with the load(s) reconnected, this indicates an internal fault in the load(s).

**Finding an earth fault**

**20** The battery negative terminal is connected to "earth" - the metal of the engine/transmission and the vehicle body - and many systems are wired so that they only receive a positive feed, the current returning via the metal of the car body. This means that the component mounting and the body form part of that circuit. Loose or corroded mountings can therefore cause a range of electrical faults, ranging from total failure of a circuit, to a puzzling partial failure. In particular, lights may shine dimly (especially when another circuit sharing the same earth point is in operation), motors (eg wiper motors) may run slowly, and the operation of one circuit may have an apparently-unrelated effect on another. Note that on many vehicles, earth straps are used between certain components, such as the engine/transmission and the body, usually where there is no metal-to-metal contact between components, due to flexible rubber mountings, etc.

**21** To check whether a component is

properly earthed, disconnect the battery and connect one lead of an ohmmeter to a known good earth point. Connect the other lead to the wire or earth connection being tested. The resistance reading should be zero; if not, check the connection as follows.

**22** If an earth connection is thought to be faulty, dismantle the connection, and clean both the bodyshell and the wire terminal (or the component earth connection mating surface) back to bare metal. Be careful to remove all traces of dirt and corrosion, then use a knife to trim away any paint, so that a clean metal-to-metal joint is made. On reassembly, tighten the joint fasteners securely; if a wire terminal is being refitted, use serrated washers between the terminal and the bodyshell, to ensure a clean and secure connection. When the connection is remade, prevent the onset of corrosion in the future by applying a coat of petroleum jelly or silicone-based grease, or by spraying on (at regular intervals) a proprietary ignition sealer, or a water-dispersant lubricant.

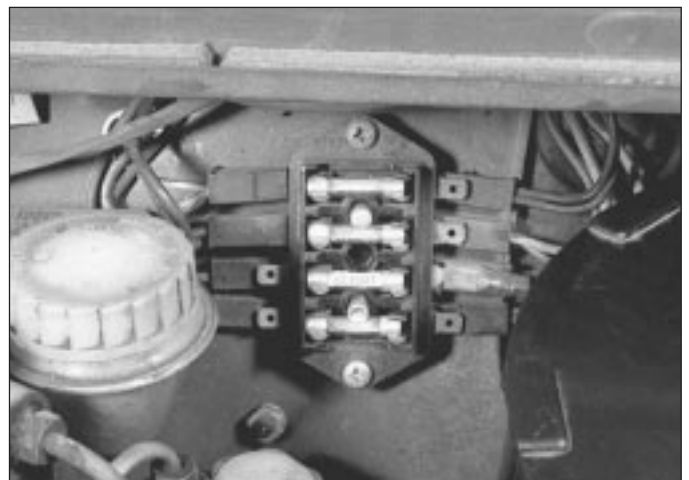

3.1b Four-fuse type fusebox location

**3 Fuses and relays - general information**



**Main fuses**

**1** The main fuses are located in a block which is mounted on the right-hand wing valance on early models, and on the right-hand side of the engine compartment bulkhead on later models (see illustrations). The fuse block is covered by a plastic push-on cover. Upon inspection it will be seen that there are two main fuses on early models and either four or twenty four main fuses on later versions. In both cases, spare fuses are contained within the fuse block or cover. The fuse positions and circuits protected are listed in the *Specifications*.

**2** To remove a fuse, simply withdraw it from the contacts in the fuse block; the wire within the fuse should be visible; if the fuse is blown, the wire will be broken or melted. Before refitting a new fuse ensure that the contacts

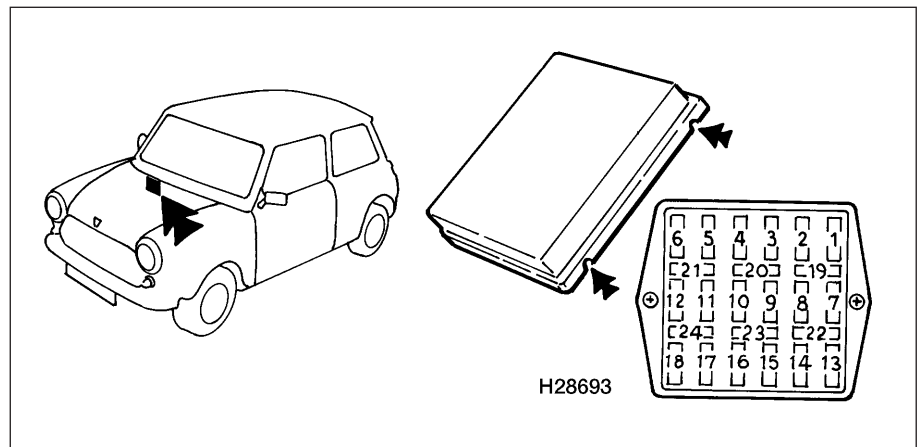

3.1c Twenty-four fuse type fuse block location

Arrows indicate fuse block cover locating notches

are clean and free from corrosion. If necessary the contacts may be cleaned with a fine grade emery paper.

**3** Always renew a fuse with one of an identical rating; never use a fuse with a different rating from the original or substitute anything else. Never renew a fuse more than once without tracing the source of the trouble.

**4** Persistent blowing of a particular fuse indicates a fault in the circuit(s) protected. Where more than one circuit is involved, switch on one item at a time until the fuse blows, so showing in which circuit the fault lies.

**5** Besides a fault in the electrical component concerned, a blown fuse can also be caused by a short-circuit in the wiring to the component. Look for trapped or frayed wires allowing a live wire to touch vehicle metal, and for loose or damaged connectors.

**6** After renewing a fuse, refit the fuse block cover, ensuring that it is pushed fully into place. The cover for the twenty four fuse block, has two notches on one side to ensure that it is fitted correctly.

### Line fuses

**7** A line fuse is fitted to protect an individual unit or circuit. Line fuses are located in clusters on the engine compartment bulkhead, behind the fascia or instrument panel, and under the bonnet lock platform. The number of fuses, and the circuits protected, depends on model and equipment fitted. To change a line fuse, hold one end of the container, press and twist off the other end.

### Relays

**8** A relay is an electrically-operated switch, which is used for the following reasons:

- a) A relay can switch a heavy current remotely from the circuit in which the current is flowing, allowing the use of lighter gauge wiring and switch contacts.
- b) A relay can receive more than one control input, unlike a mechanical switch.



**4.5 Remove the securing screws and lift off the steering column shroud**

c) A relay can have a timer function - for example an intermittent wiper delay.

**9** On later Mini models, relays are used to operate a number of circuits, mainly in the engine management and emission control systems. The engine management system relays are contained in a sealed module mounted on the engine compartment bulkhead - these cannot be individually renewed and in the event of a fault in this area, the complete module must be renewed. A relay for the Lambda (oxygen) sensor is mounted separately, also on the bulkhead. Further information on the engine management system relays will be found in Chapter 4B and 4C.

**10** Relays for circuits such as the direction indicator/hazard flasher system, and auxiliary cooling fan are also used according to model, year, and equipment fitted.

**11** If a circuit which includes a relay develops a fault, remember that the relay itself could be faulty. Testing is by substitution of a known good relay. Do not assume that relays which look similar are necessarily identical for purposes of substitution.

**12** Make sure that the ignition is switched off, then pull the relay from its socket. Push the new relay firmly in to refit.

## 4 Switches - removal and refitting



**Note:** Disconnect the battery negative lead before removing any switch and reconnect the lead after refitting the switch.

### Steering column multifunction switch

#### Early type switches incorporating direction indicator, horn and headlight main beam control

**1** Undo and remove the screws securing the two halves of the steering column shroud to the column and lift off the two halves.

**2** Undo and remove the two screws securing the switch retaining strap and lift the switch off the column.

**3** Disconnect the wiring harness connector under the parcel shell and lift away the switch.

**4** Refitting is the reverse sequence to removal.

#### Later type switches incorporating direction indicator, horn, headlight main beam and windscreen washer/wiper control

**5** Undo and remove the retaining screws and lift off the two halves of the steering column shroud (see illustration).

**6** Refer to Chapter 10 and remove the steering wheel.

**7** Disconnect the two switch multiplug connectors under the parcel shelf (see illustration).

**8** Undo and remove the retaining screw and lift out the direction indicator cancelling block.

**9** Slacken the switch clamp screw and slide the switch off the end of the steering column.

**10** If it is wished to renew either of the switches they may be renewed as a complete assembly or individually. If they are to be renewed individually, it will be necessary to drill out the two rivets securing the windscreen washer/wiper switch to the mounting plate and unwrap the insulating tape securing the harness together.

**11** Refitting is the reverse sequence to removal. Ensure that the striker dog on the nylon switch centre is in line with and adjacent to the direction indicator switch stalk.

### Facia switches

**12** Undo and remove the lower heater retaining nut and the two screws securing the front of the heater to the parcel shelf. Lower the heater to the floor. **Note:** On models fitted with a centre console, it will be necessary to remove the console and facia glovebox retaining screws to allow the console to be moved if necessary for access.

**13** On models fitted with toggle switches, unscrew the locking ring securing the switch to the panel and withdraw the switch to the rear. Make a note of the electrical connections at the rear of the switch and disconnect them.

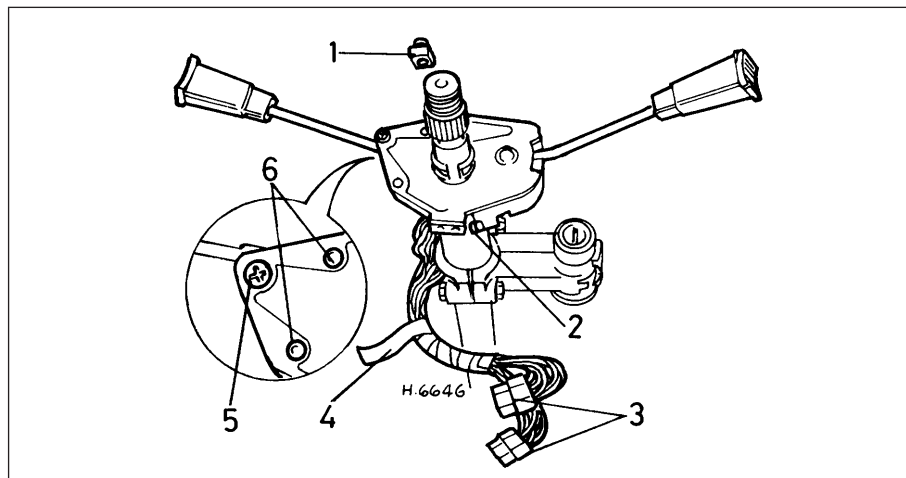

**4.7 Steering column multifunction switch**

- 1 Cancelling ring drive block
- 2 Clamp screw
- 3 Multi-plug connectors
- 4 Insulating tape
- 5 Screw
- 6 Rivet



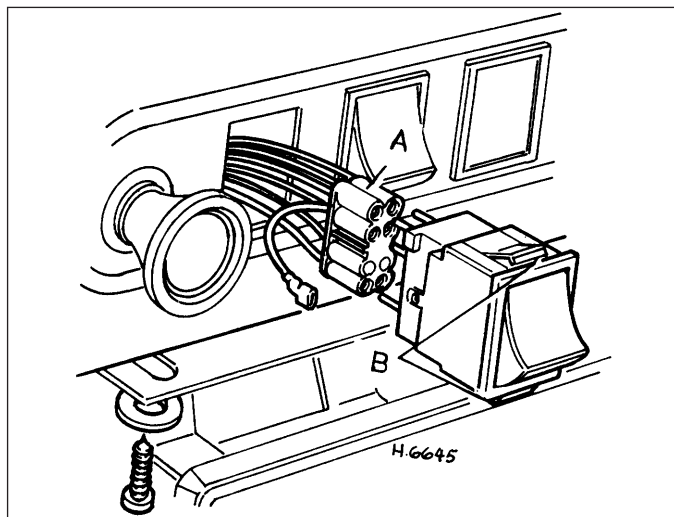

4.14 Removal of rocker type facia switch

A Multi-plug connector B Switch retaining tabs

14 On models fitted with rocker switches simply push the switch out of the panel and detach the multiplug (see illustration).

15 In both cases refitting is the reverse sequence to removal.

**Door pillar switch**

16 The interior light door pillar switches are retained by either being a push fit in the pillars, or by a single securing screw. Prise out the push fit type or remove the screw, disconnect the electrical lead and lift away the switch.



*Tape the wiring to the door pillar, to prevent it falling back into the pillar. Alternatively, tie a piece of string to the wiring to retrieve it.*

17 The switch is refitted in the reverse way.

**Stop light switch**

**Note:** The stop lights are operated either hydraulically by a pressure sensitive switch incorporated in the braking system or electrically by an on/off switch mounted above the brake pedal.

**Hydraulically operated type**

18 Remove the brake master cylinder filler cap and place a piece of polythene over the filler neck. Now refit the cap. This will prevent loss of hydraulic fluid when the stop light switch is removed.

19 Lift up the rubber cover, if fitted, and disconnect the two wires from the stop light switch located on the right-hand side of the front subframe beneath the flywheel housing (see illustration).

20 Using a large socket and extension bar, remove the switch from the pipe connector.

21 Refitting the switch is the reverse sequence to removal. If precautions were

taken to prevent fluid loss, it should not be necessary to bleed the hydraulic system. However, if the brake pedal now feels spongy, bleed the system as described in Chapter 9.

**Electrically operated type**

22 Disconnect the two wires at the switch, accessible from below the parcel shelf.

23 Undo and remove the locknut and then withdraw the switch from its mounting bracket.

24 Refitting is the reverse sequence to removal. Adjust the position of the switch and locknuts so that the stop lights operate after 6.3 mm of brake pedal travel.

**Ignition switch**

25 Undo and remove the securing screws and lift off the two halves of the steering column shroud.

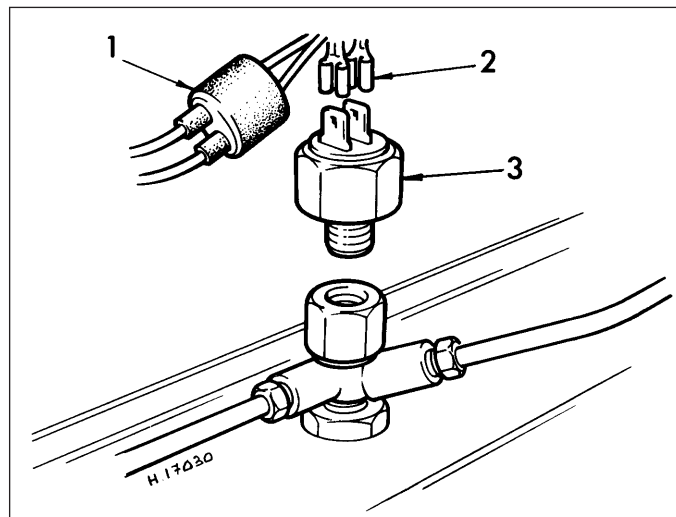

4.19 Hydraulic stop light switch removal

1 Rubber cover (where fitted) 2 Electrical leads 3 Stop light switch

26 Disconnect the ignition switch multiplug connector (see illustration).

27 Inspect the top of the ignition switch housing, and if a small screw is present, unscrew it. The ignition switch can now be withdrawn from the steering lock housing.

28 If a small retaining screw is not visible, then the ignition switch is of the sealed type and can only be removed with the steering lock housing as a complete assembly. This procedure is described fully in Chapter 10 Section 24.

29 Refitting the ignition switch is the reverse sequence to removal.

**Reversing light switch (manual transmission models)**

**Note:** The following procedures apply to later Mini Saloon models having reversing lights incorporated in the rear light clusters. The

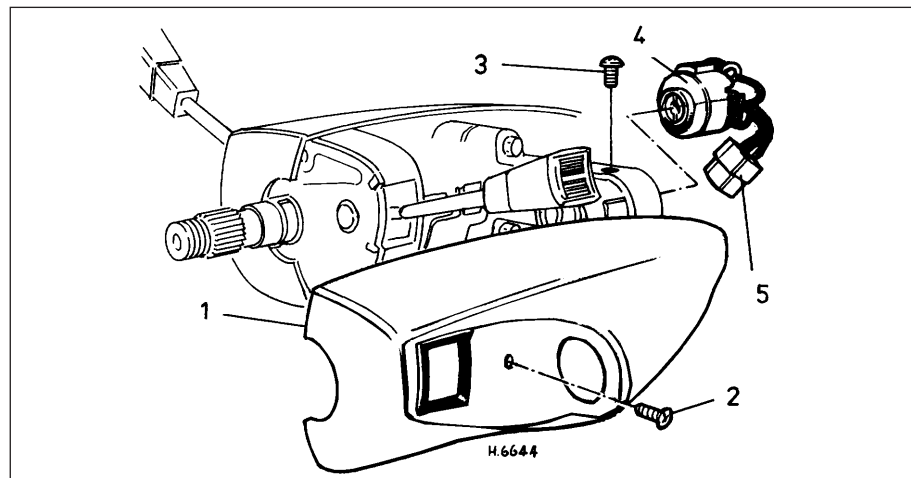

4.26 The later type ignition/starter switch

1 Steering column shroud 3 Ignition switch securing screw 4 Ignition switch 2 Shroud retaining screw 5 Multiplug connector

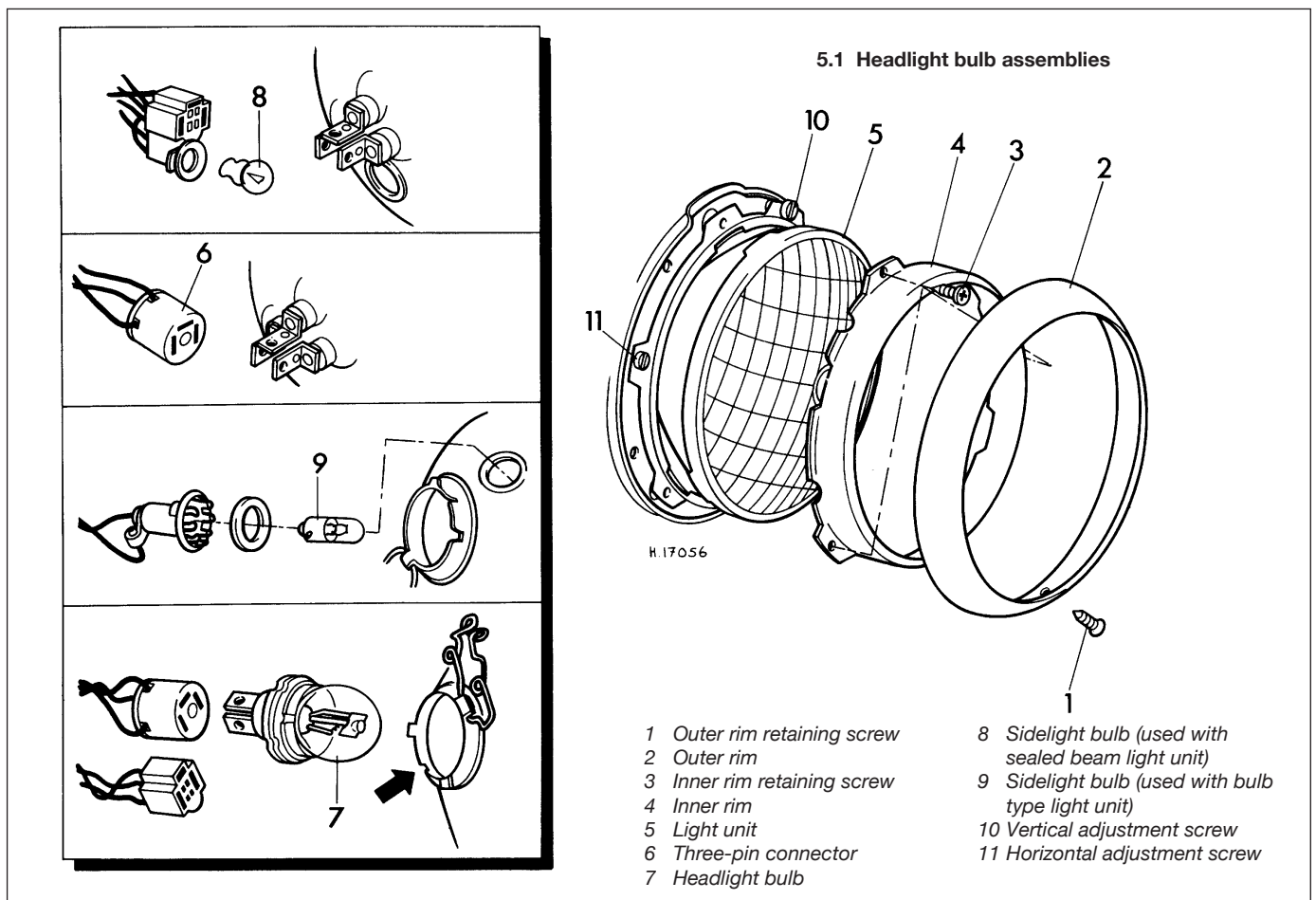

switch is located in the gearchange remote control housing and is actuated by the gearchange lever when reverse is selected.

**30** Chock the rear wheels then jack up the front of the car and support it on axle stands (see "Jacking and vehicle support").

**31** Working underneath the car, disconnect the two switch wires, slacken the locknut and unscrew the switch from the remote control housing.

**32** Refitting is the reverse sequence to removal.

**33** Adjustment is carried out as follows. With the wires disconnected, screw the switch into the housing until slight resistance is felt.

**34** Connect the wires, select reverse gear and switch on the ignition. Continue screwing the switch in until the reversing lights just come on and then screw the switch in a further quarter of a turn.

**35** Tighten the locknut and check that the reversing lights are illuminated with the gear lever in reverse and extinguished in all other gear positions. Lower the car to the ground on completion.

**Reversing light switch (automatic transmission models)**

**36** Refer to Chapter 7B.

**Starter inhibitor switch (automatic transmission models)**

**37** Refer to Chapter 7B.

**5 Bulbs (exterior lights) - renewal**

**Note:** With all light bulbs, remember that if they have just been in use, they may be very hot. Switch off the power before renewing a bulb. With quartz halogen bulbs (headlights and similar applications), use a tissue or clean cloth when handling the bulb; do not touch the bulb glass with the fingers. Even small quantities of grease from the fingers will cause blackening and premature failure. If a bulb is accidentally touched, clean it with methylated spirit and a clean rag.

**Headlight**

**1** Either sealed beam or renewable bulb light units are fitted to all Minis, depending on model type and year of manufacture (see illustration).

**2** To remove the headlight unit on Clubman and 1275 GT models, undo and remove the four screws and lift off the grille panel

extension around the light unit. On all other models undo and remove the outer rim securing screw and ease the bottom of the outer rim forwards, lift it up and off the retaining lugs at the top of the light unit (see illustrations).

**3** Proceed as follows according to light unit type.

**Sealed beam type**

**4** Undo and remove the three small inner rim securing screws and withdraw the inner rim (see illustrations). Lift out the light unit.



**5.2a** On Clubman models remove the grille panel extension for access to the headlight



5.2b On non-Clubman models, undo the outer rim securing screw . . .



5.2c . . . and lift the rim off the upper lugs



5.4a Unscrew the inner rim securing screws . . .

5 Withdraw the three pin connector from the rear of the reflector and lift away the complete unit (see illustration).

6 Refitting is the reverse sequence to removal.

**Renewable bulb type**

7 Undo and remove the three small inner rim securing screws and withdraw the inner rim. Lift out the light unit.

8 Withdraw the three pin connector from the rear of the reflector and disengage the spring clip from the reflector lugs. Lift away the bulb. Note the locating pip on the reflector and mating indentation in the bulb rim.

9 Refitting is the reverse sequence to removal. Ensure that the indentation in the bulb rim locates over the locating pip on the reflector.

**Alternative renewable bulb type**

10 On certain models an alternative bulb type headlight assembly of slightly different design to the standard unit may be fitted (see illustration).

11 To renew a bulb on these units, first remove the outer rim as described in paragraph 2.

12 Carefully pull the three adjusting screws one at a time out of their locations and lift out the reflector.

13 Withdraw the three pin connector from the rear of the reflector and disengage the spring clip from the reflector lugs. Lift away the bulb. Note the position of the projection on the bulb rim in relation to the bulb locator and ensure that the new bulb is fitted correctly.

14 Refitting is the reverse sequence to removal. Ensure that the projection on the bulb rim is correctly engaged with the bulb locator.

**Auxiliary driving light - Cooper models**

15 Undo and remove the screw and release the clamp securing the reflector to the light unit.

16 Withdraw the reflector and disconnect the bulb wiring connector.

17 Disengage the spring clip from the reflector lugs and lift away the bulb.

18 Refitting is the reverse sequence to removal.



5.4b . . . and lift off the inner rim



5.5 Detach the electrical connector and lift away the light unit

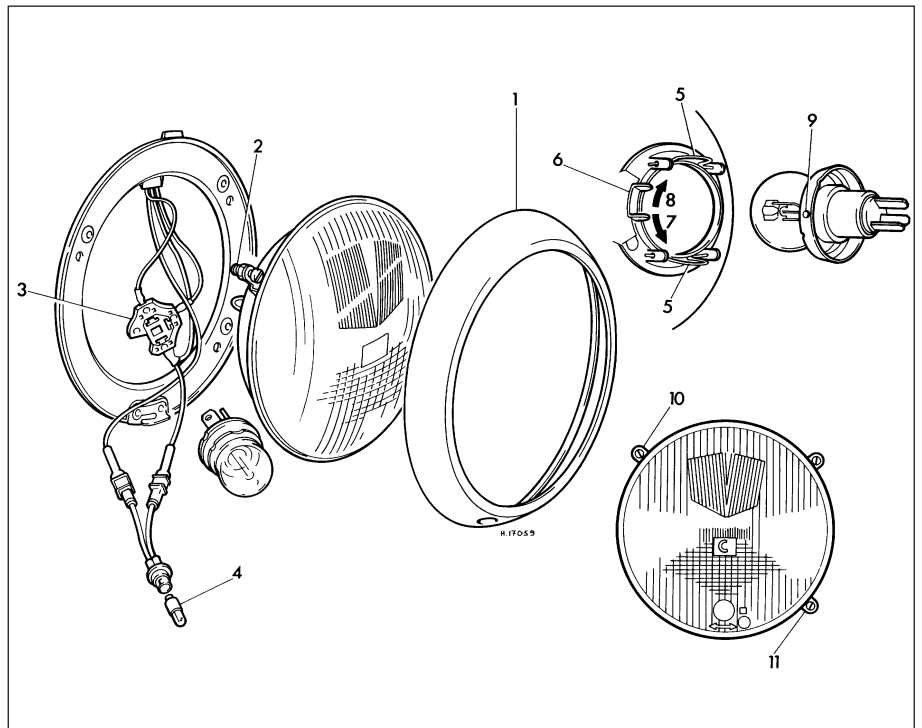

5.10 Alternative type headlight assembly

- |                       |  |                                |
|-----------------------|--|--------------------------------|
| 1 Outer rim           | 6 Bulb locator   | 9 Projection on bulb           |
| 2 Adjusting screws    | 7 Position of bulb locator for right-hand drive vehicles | 10 Horizontal adjustment screw |
| 3 Three pin connector | 8 Position of bulb locator for left-hand drive vehicles  | 11 Vertical adjustment screw   |
| 4 Sidelight bulb      |  |                                |
| 5 Spring clip         |  |                                |



5.24 Undo the two screws and lift off the lens

**Front sidelight**

All models except Clubman and 1275 GT

19 Undo and remove the headlight outer rim securing screw and ease the bottom of the outer rim forwards, lift it up and off the retaining lugs at the top of the light unit.

20 Undo and remove the three small headlight inner rim securing screws and withdraw the inner rim. Lift out the light unit.

21 Where a sealed beam headlight unit is fitted, disconnect the headlight bulb wiring connector and remove the sidelight bulb from the wiring connector block; it will be either a push-fit or bayonet type fitting.

22 Where a renewable bulb type light unit is fitted, withdraw the sidelight bulbholder from the rear of the reflector. Remove the bayonet fitting type bulb from the holder.

23 Refit the bulb and headlight unit using the reverse sequence to removal.

**Clubman and 1275 GT models**

24 Undo and remove the two screws that secure the lens to the light body. Carefully lift away the lenses (see illustration).

25 Push in the bayonet fitting bulb slightly and turn it anti-clockwise to remove.

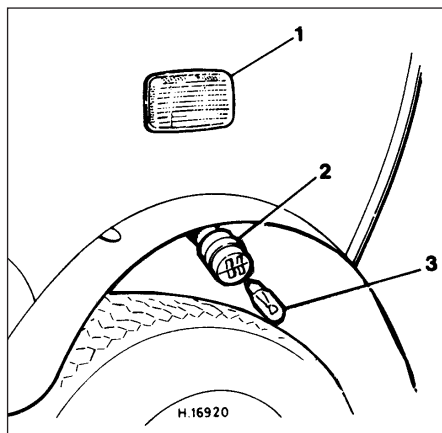

5.31 Direction indicator side repeater details

- 1 Light unit
- 2 Bulb holder
- 3 Bulb



5.27a Fold back the rubber flange and remove the rim . . .



5.27b . . . and lens

26 Refitting is the reverse sequence to removal. Take care not to over tighten the two lens retaining screws as the lenses can be easily cracked.

**Front direction indicator**

All models except Clubman and 1275 GT

27 To renew a bulb, very carefully fold back the rubber flange with the aid of a screwdriver and remove the plated rim and lens (see illustrations). On later models the lens is secured by two screws.

28 Push the bulb in slightly and turn it anti-clockwise to remove it (see illustration).

29 Refitting is the reverse of the removal procedure, but ensure that the plated rim is secured all round by the rubber flange, if applicable.

**Clubman and 1275 GT models**

30 The procedure is the same as described previously for the front sidelight bulb.

**Front direction indicator side repeater**

31 Access to the rear of the light and the bulbholder is gained through the front wheel arch (see illustration).

32 Push the bulbholder in and rotate it, this will release it from the rear of the light unit and allow the holder and electrical lead to be drawn down out of the wheel arch.

33 The push-fit bulb can now be removed from the holder.

34 Refitting is the reverse of removal.



5.35a Rear light cluster lens removed for bulb renewal - Saloon models



5.28 Push and turn the bulb anti-clockwise to remove

**Stop/tail and rear direction indicator**

35 Undo the three screws to release the light lenses (see illustrations).

36 The direction indicator bulb is fitted in the top compartment and the stop/tail bulb in the lower compartment (or centre compartment on later models).

37 Both bulbs have bayonet fixings; to remove push in slightly, and rotate anti-clockwise.

38 Refitting is the reverse sequence to removal. Take care not to overtighten the lens securing screws as the lenses can easily be cracked.

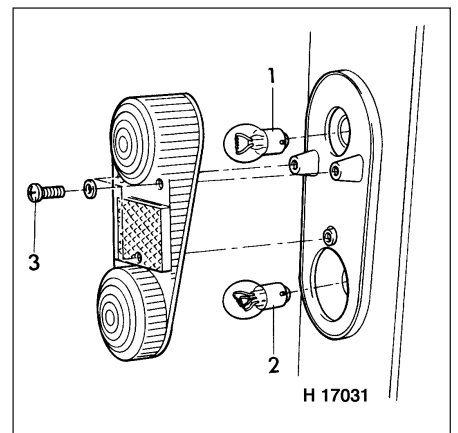

5.35b Rear light bulb renewal - Estate, Van and Pick-up models

- 1 Direction indicator bulb
- 2 Stop/tail bulb
- 3 Securing screws





5.44 Removal of the number plate lens and bulb holder on Saloon models

**Reversing light**

39 On later models the rear light clusters are increased in size to accommodate a reversing light bulb.

40 The reversing light bulb is fitted to the lower of the three compartments in the rear light clusters and its renewal is the same as for the stop/tail and direction indicator bulbs described previously.

**Rear foglight**

41 Access to the bulb is gained by removing the two lens cover screws and pulling off the lens.

42 The bayonet-fit bulb can now be removed from the holder by pushing in slightly, and rotating anti-clockwise.

43 Refitting is the reverse sequence to removal.

**Number plate light**

**Saloon models**

44 Undo and remove the lens securing screws and carefully ease the lens and bulb holder out of the light unit. In some cases it will be found that the lens and bulb holder cannot be withdrawn due to the wires fouling the light unit. If this happens, open the boot

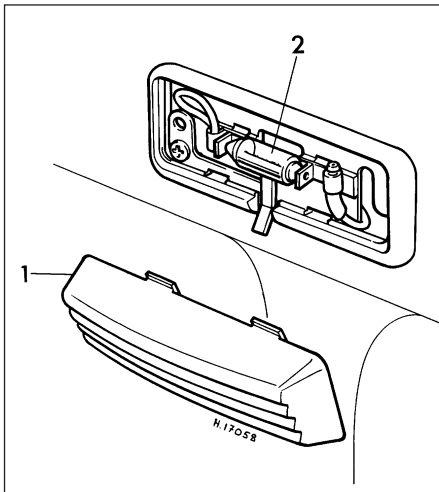

6.1 Interior light bulb renewal  
1 Lens                      2 Bulb



5.47 On Estate, Van and Pick-up models lift off the cover and lens . . .

lid, remove the three retaining screws and lift off the light unit. The lens and bulb holder can now be removed (see illustration).

45 The festoon type bulb is removed by simply withdrawing it from the bulb holder contacts.

46 Refitting is the reverse sequence to removal.

**Estate, Van and Pick-up models**

47 Undo and remove the retaining screw and lift off the cover and lens (see illustration).

48 Remove the bulbs by turning anti-clockwise and lifting out (see illustration).

49 Refitting is the reverse sequence to removal.

**6 Bulbs (interior lights) - renewal**



**Note:** With all light bulbs, remember that if they have just been in use, they may be very hot. Switch off the power before renewing a bulb.

**Interior courtesy light - early type**

1 Carefully squeeze the two sides of the courtesy light plastic lens together until the retaining lugs of the lens are clear of the sockets in the light base (see illustration).

2 Draw the lens from the light base.

3 The festoon bulb may now be detached from the contact blades.

4 Refitting the bulb and lens is the reverse sequence to removal.

**Interior courtesy light and glovebox light - later type**

5 Release the light unit by carefully prising out the end furthest from the switch.

6 The bayonet-fit bulb can now be removed from the bulb holder by pushing in slightly, and rotating anti-clockwise.

7 Refitting is the reverse sequence to removal.

**Footwell light**

8 Release the light unit from its mounting below the fascia.

9 The festoon bulb may now be detached from the contact blades.



5.48 . . . and remove the bulbs by turning them anti-clockwise

10 Refitting is the reverse sequence to removal.

**Switch illumination**

11 To renew a bulb in the illuminated switches fitted to later models, insert a small screwdriver under the notch on both sides of the switch rocker. Depress the notch slightly and lever off the rocker. The bulb may be unscrewed for renewal using the outer plastic casing of a wiring connector which is a snug fit over the bulb lens.

12 Refit the bulb and push the switch rocker back into place.

**Instrument panel illumination and warning lights**

**Models with central instrument panel**

13 Access to the instrument panel warning lights and panel illumination lights is gained from the engine compartment by withdrawing the push type bulb holders from the rear of the speedometer and instruments.

14 On later models it may be helpful to remove the air cleaner assembly as described in the relevant Part of Chapter 4 to provide greater access.

**Models with offset instrument panel**

15 On models having an instrument panel in front of the driver, access to the bulbs is through an access panel beneath the parcel shelf and from the side of the panel after the fascia trim has been eased back. Alternatively, for greater access, the instrument panel may be removed as described in Section 15.

16 The bulb holders are a push fit in the rear of the instrument panel and the capless bulbs are also a push fit in the holders.

**7 Headlight beam alignment - checking and adjusting**



1 The headlights may be adjusted for both vertical and horizontal beam positions by means of the two adjusting screws. On the standard fitting sealed beam and bulb type headlight units, the upper spring-loaded screw adjusts the vertical position and the side spring-loaded screw adjusts the

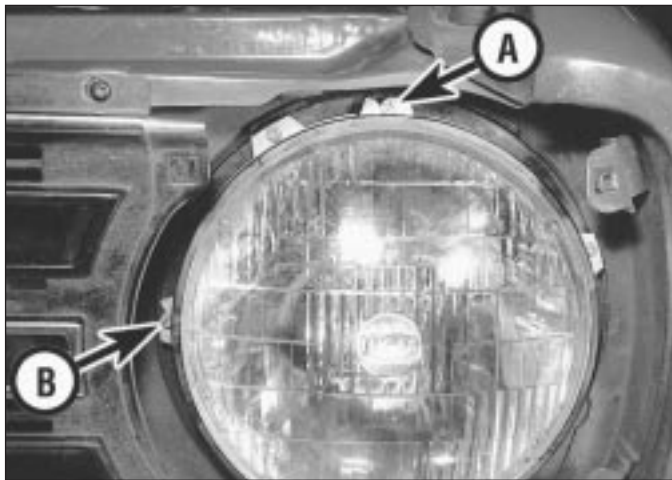

7.1 Headlight vertical position A and horizontal position B adjusting screws

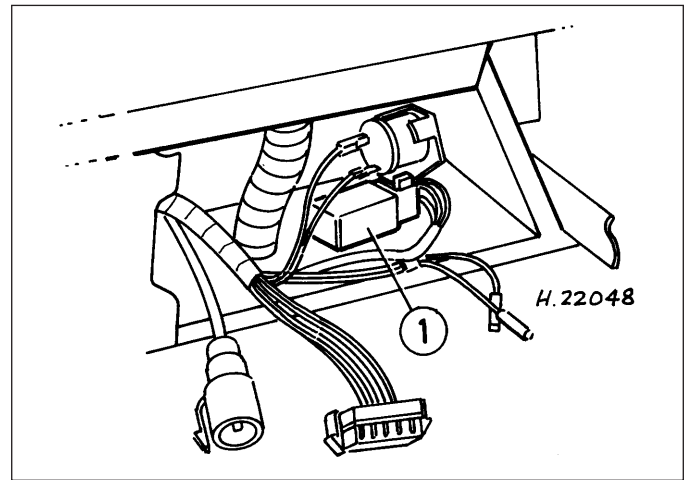

8.2 Location of dim-dip lighting unit (1) behind the instrument panel

horizontal position (see illustration). On the alternative type headlight units, the two diametrically opposite screws are used for adjustment. The upper screw adjusts the horizontal setting and the lower screw adjusts the vertical setting.

2 The lights should be set so that on full or high beam, the beams are set slightly below parallel with a level road surface. Do not forget that the beam position is affected by how the car is normally loaded for night

driving, and set the beams with the car loaded to this position.

3 Although this adjustment can be approximately set at home, it is recommended that beam alignment is carried out by a Rover dealer or other specialist having the necessary optical alignment equipment.

5 Open the bonnet, and unclip the wiring loom connector on the right-hand side of the engine compartment (see illustration).

6 Pull the resistor plug from the connector, and release the wiring loom.

7 Unscrew the mounting bolt, and withdraw the resistor and mounting plate.

**Refitting**

8 Refitting is the reverse sequence to removal.

**8 Dim-dip lighting system components - removal and refitting**



**Dim-dip unit**

**Removal**

1 Remove the instrument panel as described in Section 15.

2 Disconnect the dim-dip unit from the wiring loom connector (see illustration).

**Refitting**

3 Refitting is the reverse sequence to removal.

**Dim-dip resistor**

**Removal**

4 Disconnect the battery negative lead.

**9 Horn - removal, refitting and adjustment**



**Removal and refitting**

1 The horn is located in the engine compartment and is attached to a bracket, which is in turn secured to the front body panel by two small nuts and bolts (see illustration).

2 To remove the unit, disconnect the horn wiring then undo the retaining bracket nuts and bolts. Remove the horn, complete with bracket, then remove the bracket. The horn is not repairable and should not be dismantled.

3 Refitting is the reverse sequence to removal.

**Adjustment**

4 On early type horns an adjustment is provided to compensate for wear of the moving parts.

5 Adjustment is by means of a screw on the broad rim of the horn nearly opposite the two terminals. Do not confuse this with the large screw in the centre.

6 Turn the adjustment screw anti-clockwise until the horn just fails to sound. Then turn the screw a quarter of a turn clockwise, which is the optimum setting.

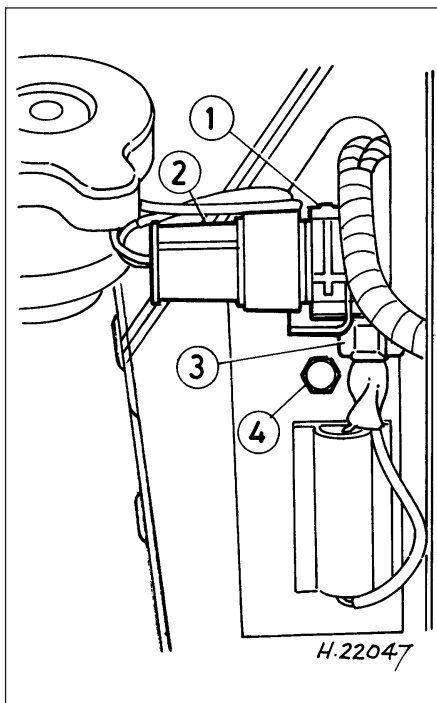

8.5 Location of dim-dip resistor

- 1 Wiring loom connector
- 2 Resistor plug
- 3 Wiring loom clip
- 4 Mounting plate bolt



9.1 Horn location showing electrical leads and mounting nuts

**10 Windscreen wiper arms - removal and refitting**



**Removal**

**1** Before removing a wiper arm, turn the windscreen wiper switch on and off, to ensure that the arms are in their normal parked position with the blades parallel to the bottom of the windscreen.

**2** To remove the arm, pivot the arm back and pull the wiper arm head off the splined drive, at the same time easing back the clip with a screwdriver (see illustration).

**Refitting**

**3** When refitting an arm, place it so it is in the correct relative parked position and then press the arm head onto the splined drive until the retaining clip clicks into place.



**10.2** The wiper arm is a push fit on the wiper spindle splines

connector from the motor, and if a separate earth wire is fitted, detach this from the wing valance.

**4** Undo the nut securing the cable rack guide tube to the wiper motor gearbox (see illustration).

**5** Undo and remove the two motor strap retaining screws and lift off the strap.

**6** Carefully withdraw the motor assembly pulling the cable rack from the guide tubes.

**Refitting**

**7** To refit the motor, lightly lubricate the cable rack with a general purpose grease.

**8** Enter the cable rack into the guide tubes and carefully push it through, ensuring that it engages the wheelbox gear teeth.

**9** Refit the motor retaining strap and the guide tube retaining nut.

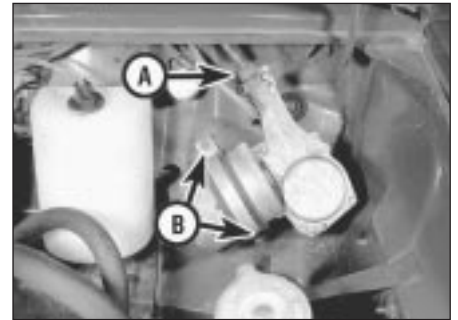

**11.4** Cable rack guide tube retaining nut A and motor strap retaining screws B

**10** Reconnect the electrical leads and the battery terminal.

**11** Switch on the wipers, check the function of the motor and then turn it off. With the motor now in the "park" position, refit the wiper arms.

**11 Windscreen wiper motor - removal and refitting**



**Removal**

**1** Remove the wiper arms from the spindles as described in Section 10.

**2** Disconnect the battery negative lead.

**3** Withdraw the electrical cable terminal

**12 Windscreen wiper motor - dismantling and reassembly**



**Dismantling**

**1** Due to the limited availability of spare parts, the only repair which can be effectively undertaken on the motor is the renewal of the brushes and the limit switch. Anything more serious than this will mean exchanging the

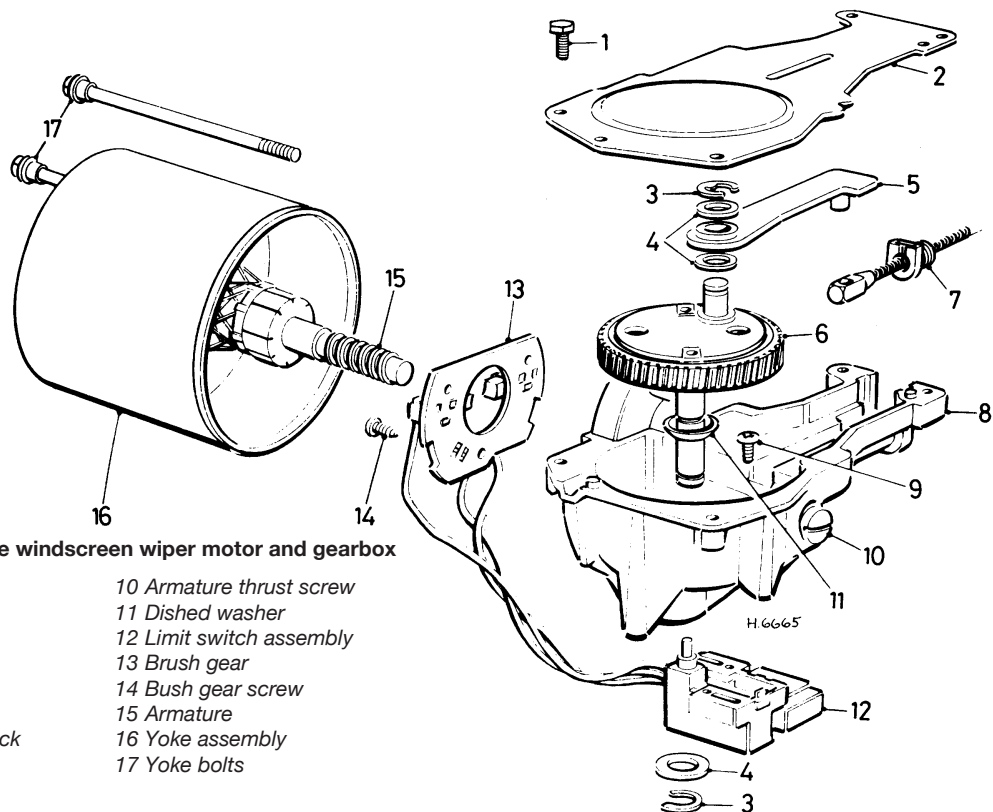

**12.2** Exploded view of the windscreen wiper motor and gearbox

- |                       |                          |
|-----------------------|--------------------------|
| 1 Cover screw         | 10 Armature thrust screw |
| 2 Gearbox cover       | 11 Dished washer         |
| 3 Circlip             | 12 Limit switch assembly |
| 4 Plain washers       | 13 Brush gear            |
| 5 Connecting rod      | 14 Bush gear screw       |
| 6 Shaft and gear      | 15 Armature              |
| 7 Cross-head and rack | 16 Yoke assembly         |
| 8 Gearbox             | 17 Yoke bolts            |
| 9 Limit switch screw  |                          |

complete motor or having a repair undertaken by an automobile electrician.

**2** With the motor removed from the car as described in Section 11, undo and remove the four gearbox cover retaining screws and lift away the cover (**see illustration**). Release the circlip and flat washer securing the connecting rod to the crankpin on the shaft and gear. Lift away the connecting rod followed by the second flat washer.

**3** Raise the circlip and flat washer securing the shaft and gear to the gearbox body.

**4** De-burr the gearshaft and lift away the gear, making a careful note of the location of the dished washer.

**5** Scribe a mark on the yoke assembly and gearbox to ensure correct reassembly, and unscrew the two yoke bolts from the motor yoke assembly. Part the yoke assembly, including armature, from the gearbox body. As the yoke assembly has residual magnetism ensure that the yoke is kept well away from metallic dust.

**6** Unscrew the two screws securing the brushgear and the terminal and switch assembly and remove both the assemblies.

**7** Inspect the brushes for excessive wear. If the main brushes are worn to less than the minimum specified length, or the narrow section of the third brush is worn to the full width of the brush, fit a new brushgear assembly. Ensure that the three brushes move freely in their boxes.

**8** If either the brushes or the limit switch are to be renewed on early motor assemblies, it will be necessary to unsolder the wires at the switch and then re-solder the new wires. On later types the wires are retained by Lucar connectors which are simply detached. In all cases make a note of the wire positions before disconnecting.

### Reassembly

**9** Reassembly of the windscreen wiper motor is the reverse sequence to dismantling.

## 13 Windscreen wiper wheelbox - removal and refitting



### Removal

**1** Remove the windscreen wiper motor as described in Section 11.

**2** Carefully lift back the engine compartment bulkhead insulation to provide access to the wheelboxes.

**3** Undo and remove the retaining nut and spacer from each wheelbox (**see illustration**).

**4** Slacken the nuts that clamp the guide tubes between the wheelbox plates and then lift out the guide tubes.

**5** The wheelboxes can now be lifted out.

**6** With the wheelboxes removed, withdraw the wheelbox plates and lift out the spindle and gear. Examine the gear teeth for wear and renew as necessary.

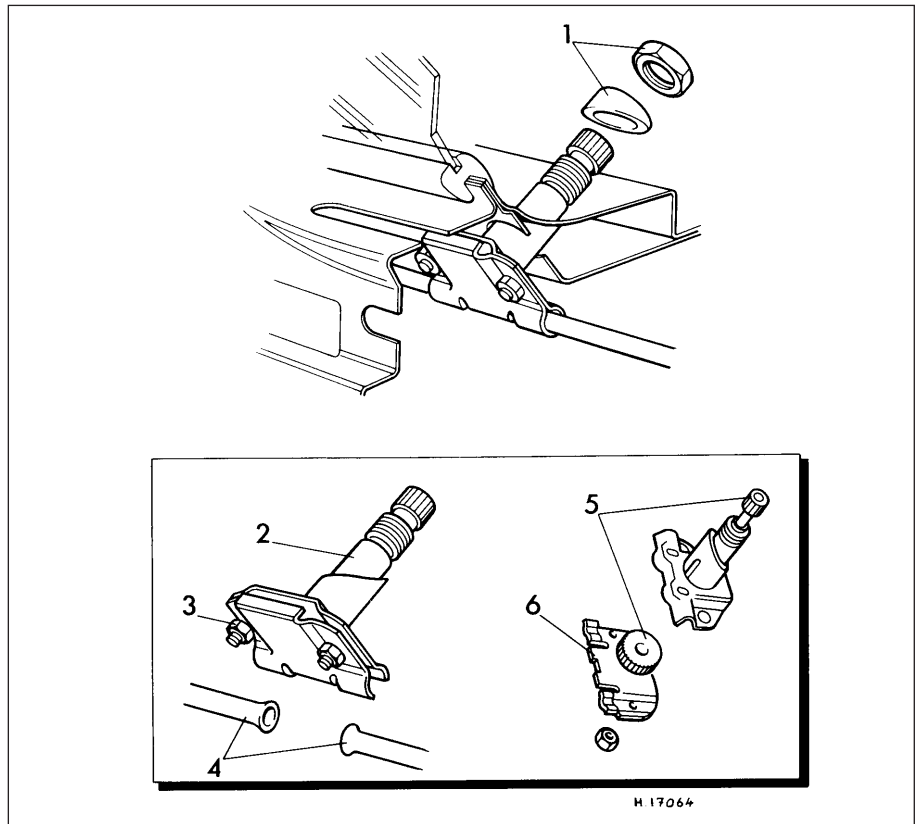

13.3 Windscreen wiper wheelbox assembly

- |                            |                                  |                    |
|----------------------------|----------------------------------|--------------------|
| 1 Retaining nut and spacer | 3 Wheelbox plate retaining screw | 5 Spindle and gear |
| 2 Wheelbox body            | 4 Wiper rack guide tubes         | 6 Lower plate      |

### Refitting

**7** Refitting is the reverse sequence to removal; bearing in mind the following points.

- Lightly lubricate the spindles and gear teeth with a general purpose grease
- Do not tighten the nuts that clamp the guide tubes between the wheelbox plates until the motor and cable rack have been refitted
- Ensure that the bend radius on the guide tube nearest to the motor is not less than 230.0 mm

**4** Detach the two water hoses from the rear of the pump and lift it away.

### Refitting

**5** Refitting is the reverse sequence to removal.

### Electric pump - early models

#### Removal

- Disconnect the battery negative lead.
- Refer to Chapter 4A or 4B as applicable and remove the air cleaner.
- Disconnect the two electrical wires and the two water hoses from the pump.
- Undo and remove the two securing screws and lift off the pump.

#### Refitting

**10** Refitting is the reverse sequence to removal. Make sure that the water hoses are connected to the correct outlets. Arrows on the pump body indicate the direction of water flow.

### Electric pump and reservoir - later models

#### Removal

**11** On later models the washer pump and reservoir are located in the luggage compartment. The pump is clipped into the side of the reservoir (**see illustration**).

## 14 Windscreen washer pump - removal and refitting



### Manual pump - early models

#### Removal

- Disconnect the battery negative lead.
- Undo and remove the retaining nut at the rear of the heater and the two screws securing the front of the heater to the parcel shelf. Lower the heater to the floor.
- Unscrew the locking ring securing the washer pump to the centre of the switch panel and pull the pump out from the rear of the panel.



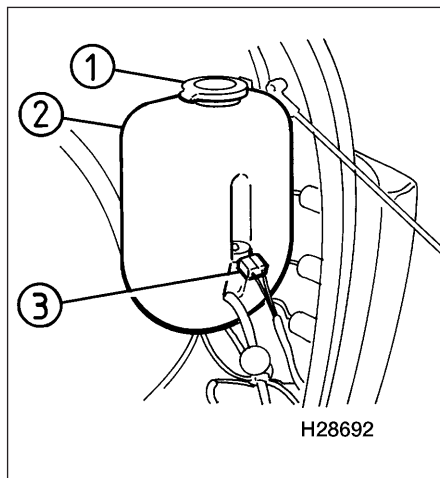

**14.11 Washer pump and reservoir location in the luggage compartment on later models**

- 1 Filler cap
- 2 Reservoir
- 3 Pump and wiring multiplug

**12** To renew either item, first disconnect the battery negative lead.

**13** Carefully prise the wiring connector from the pump.

**14** Pull the reservoir upwards from its retaining bracket. Drain the fluid into a container.

**15** Release the washer tube from the pump. The reservoir can now be removed completely.

**16** Detach the pump from the reservoir.

**Refitting**

**17** Refitting is the reverse sequence to removal, noting the following:

- a) Use a new pump seal. Fit the seal in the reservoir and lubricate it before refitting the pump.
- b) If the washer tube is difficult to replace onto the pump, soften it by immersing it in hot water for a few minutes.
- c) Top-up the reservoir with reference to "Weekly Checks" and test the operation of the washers.

**15 Instrument panel - removal and refitting**



**Models with central instrument panel (except Mini 850)**

**Removal**

- 1** Disconnect the battery negative lead.
- 2** Carefully ease out the trim panels at the rear of the facia on either side of the instrument panel.
- 3** Fold back the parcel shelf cover around the front of the instrument panel.
- 4** Slacken the nut securing the heater unit to the rear mounting bracket. Undo and remove the two screws securing the front of the heater to the parcel shelf and lower the unit to the floor.

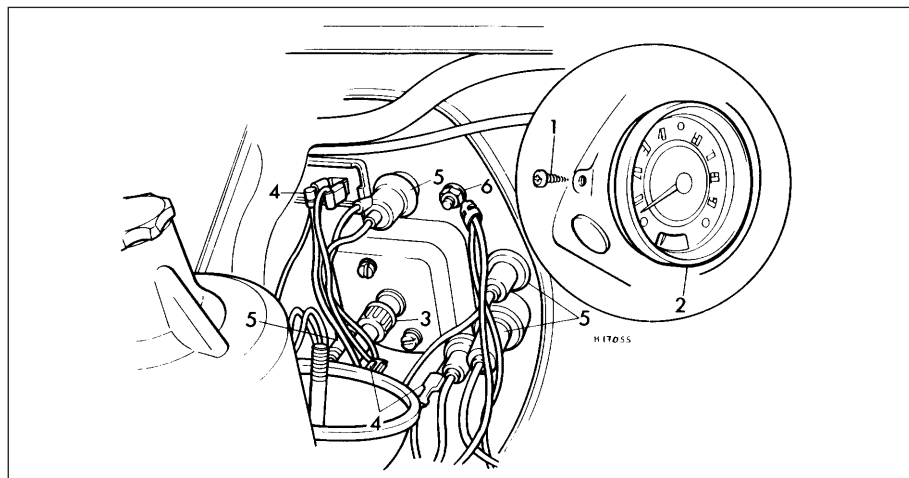

**15.18 Instrument panel removal - 850 models**

- 1 Retaining screw
- 2 Instrument panel
- 3 Speedometer cable
- 4 Wiring connectors
- 5 Bulb holders
- 6 Earth lead

**5** Undo and remove the screws securing the instrument panel to the facia.

**6** Working in the engine compartment, remove the air cleaner as described in the relevant Part of Chapter 4.

**7** Unscrew the knurled nut securing the speedometer cable to the rear of the speedometer and withdraw the cable.

**8** Remove the clip that secures the oil pressure gauge pipe to the engine compartment bulkhead.

**9** From inside the car draw the instrument panel away from the facia and disconnect the wires and bulb holders from the rear of the instruments. Label each wire as it is removed to prevent confusion when refitting.

**10** Unscrew the union nut and release the oil pipe from the rear of the oil pressure gauge.

**11** Unscrew the knurled retaining nuts and lift out the instruments.

**12** Undo and remove the two securing screws and lift out the speedometer and sealing ring.

**13** If required, the fuel gauge and voltage stabiliser may be removed from the rear of the speedometer after removing the retaining screws and nuts.

**Refitting**

**14** Reassembly and refitting of the instruments and panel is the reverse sequence to dismantling and removal.

**Mini 850 models**

**Removal**

- 15** Disconnect the battery negative lead.
- 16** Working in the engine compartment, remove the air cleaner as described in the relevant Part of Chapter 4.
- 17** Withdraw the sound insulation from speedometer aperture.
- 18** Unscrew the knurled retaining nut and detach the speedometer cable from the rear of the speedometer (see illustration).

**19** Disconnect the wires from the fuel gauge and voltage stabiliser. Label each wire as it is removed to prevent confusion when refitting.

**20** Note the locations of the bulb holders and remove them from the rear of the speedometer.

**21** Disconnect the earth wire.

**22** From inside the car undo and remove the two screws securing the speedometer to the cowl and then lift out the speedometer.

**Refitting**

**23** Refitting is the reverse sequence to removal.

**Models with offset instrument panel**

**Removal**

**24** Disconnect the battery negative lead.

**25** Hold both sides of the instrument nacelle and carefully pull it off the instrument cluster (see illustration). On some models the nacelle is secured by screws.

**26** Remove the upper plastic trim strip to gain access to the panel upper retaining screws.

**27** Undo and remove the side and upper retaining screws securing the instrument panel to the mounting brackets (see illustrations).



**15.25 Remove the instrument cluster nacelle**

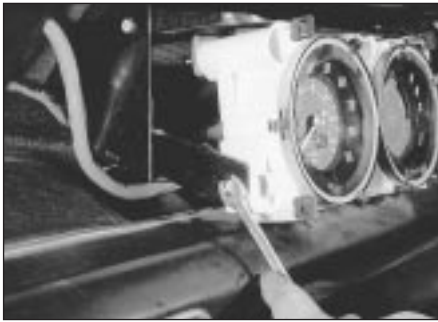

15.27a Undo the side . . .



15.27b . . . and upper retaining screws



15.28a Detach the speedometer cable . . .

28 Draw the panel outward and detach the speedometer cable, the wiring multiplug connector and (where fitted) the two electrical leads at the rear of the tachometer (see illustrations).

29 Carefully lift away the instrument panel, taking care not to damage the printed circuit.

**Refitting**

30 Refitting is the reverse sequence to removal.

**Models with wooden facia**

31 Refer to the removal and refitting procedures for the wooden facia as described in Chapter 11, which include details of instrument panel removal.

**16 Instrument panel - dismantling and reassembly**



**Note:** On models fitted with a centrally mounted panel the instruments and components are withdrawn as part of the instrument panel removal sequence (see Section 15). The following procedure is therefore applicable to models having an offset instrument panel mounted in front of the driver.

**Dismantling**

1 Remove the instrument panel as described in Section 15.

**Fuel and temperature gauge**

2 Ease off the spring clips securing the



15.28b . . . and the multiplug connector, then lift away the instrument panel

instrument lens glass and carefully remove the glass, sealing rings and printed face plate (see illustration).

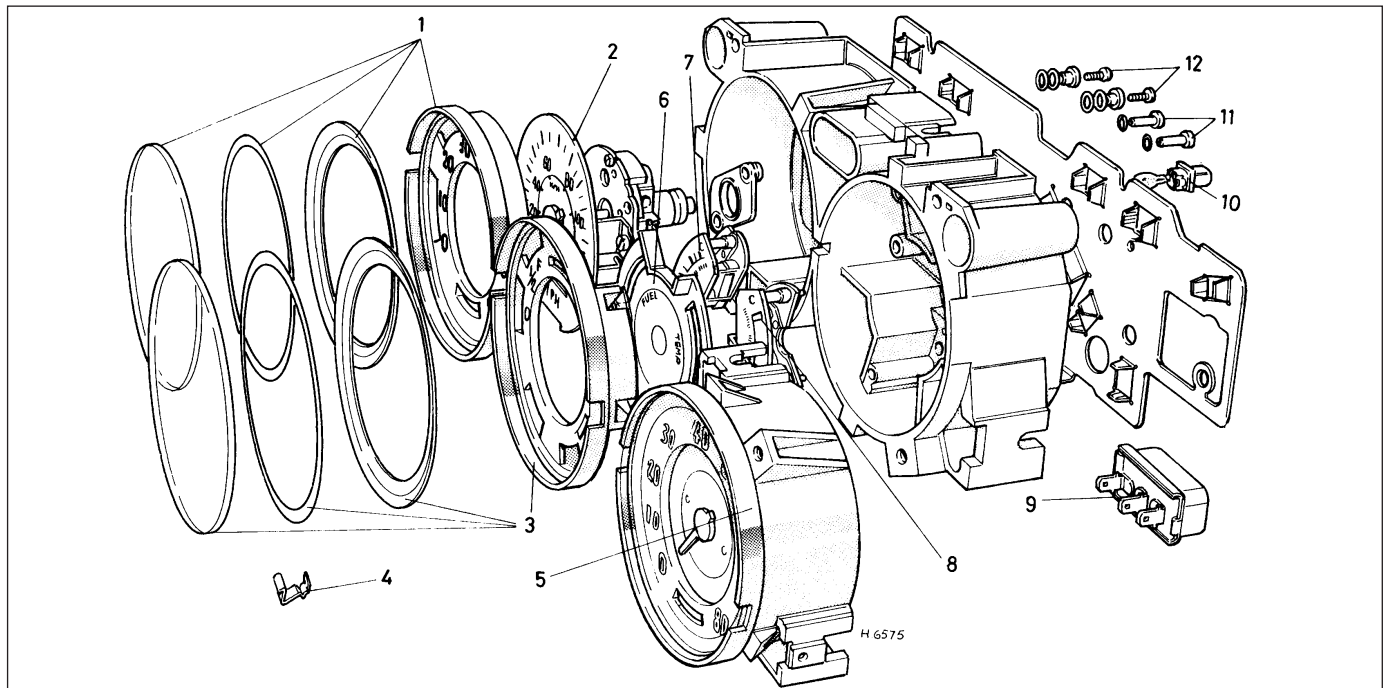

16.2 Exploded view of the offset instrument cluster

1 Speedometer lens and faceplate assembly  
2 Speedometer unit

3 Fuel/temperature gauge lens and faceplate assembly  
4 Lens securing clips  
5 Tachometer assembly (where fitted)

6 Fuel/temperature gauge facing  
7 Fuel gauge  
8 Temperature gauge  
9 Voltage stabiliser  
10 Panel lamp bulb and holder

11 Fuel/temperature gauge securing screws  
12 Speedometer securing screws

3 Undo and remove the three small screws and lift out the instrument facing.

4 At the rear of the instrument panel, undo and remove the two screws securing the gauge to the panel body and remove the gauge.

**Speedometer**

5 Ease off the spring clips securing the speedometer lens glass and carefully remove the glass, sealing rings and printed face plate.

6 At the rear of the instrument panel undo and remove the two screws securing the speedometer to the panel body and remove the speedometer.

**Tachometer**

7 Detach the voltage stabiliser lead and bulb holder from the rear of the tachometer.

8 Carefully prise up the pegs securing the printed circuit to the tachometer body and lift the unit away.

**Printed circuit and voltage stabiliser**

9 Pull the voltage stabiliser carefully out of its location in the printed circuit at the rear of the instrument panel (see illustration).

10 Withdraw the panel and warning light bulb holders.

11 Where fitted, undo and remove the three screws and the voltage stabiliser tag connections for the tachometer.

12 Undo and remove the four screws securing the fuel and temperature gauges.

13 Carefully prise out the plastic pegs securing the printed circuit to the instrument panel and lift off the printed circuit.

**Reassembly**

14 In all cases reassembly is the reverse of the dismantling sequence.

**17 Speedometer cable - removal and refitting**



**Removal**

**Models with central instrument panel**

- 1 Disconnect the battery negative lead.
- 2 Working in the engine compartment, detach the speedometer cable from the rear of the speedometer by unscrewing the knurled retaining nut and pulling the cable into the engine compartment.
- 3 Release the cable from the cable clip on the bulkhead

**Models with offset instrument panel**

- 4 Disconnect the battery negative lead.
- 5 Hold both sides of the instrument nacelle and carefully pull it off the instrument panel. On some models the nacelle is secured by screws.
- 6 Remove the upper trim strip to gain access to the upper instrument panel retaining screws.
- 7 Undo and remove the side and upper retaining screws securing the instrument panel to the mounting brackets.
- 8 Draw the panel outward slightly, depress the lug on the side of the speedometer cable connector and withdraw the cable off the end of the speedometer.
- 9 Pull the cable through the bulkhead grommet and into the engine compartment.

**All models**

- 10 Working under the car disconnect the cable from the transmission. To gain access, work through the aperture above the left-hand driveshaft.
- 11 Should the cable securing nut be tight to turn by hand, remove the bolt that secures the

speedometer drive and withdraw the cable complete with the drive assembly. The cable may then be detached from the drive assembly.

**Refitting**

12 Refitting the speedometer cable is the reverse sequence to removal but the following additional points should be noted:

- a) If the speedometer drive was removed, always fit a new joint washer.
- b) To lubricate the inner cable, withdraw the inner cable and lightly grease it except for 200 mm at the speedometer end. Refit the inner cable and wipe away any surplus grease.

**18 Radio - removal and refitting**



**Note:** If the radio incorporates an anti-theft system, once the battery has been disconnected, the radio unit cannot be re-activated until the appropriate security code has been entered. Do not remove the unit unless the appropriate code is known.

**Removal**

- 1 De-activate the radio security code (where applicable).
- 2 Disconnect the battery negative lead.

**Centre console mounted radio**

3 Removal and refitting of the radio is included in the centre console removal and refitting procedures described in Chapter 11.

**1989 onwards models with radio beneath the facia**

4 Prise the side covers from the radio, then loosen the two small screws (see illustration).

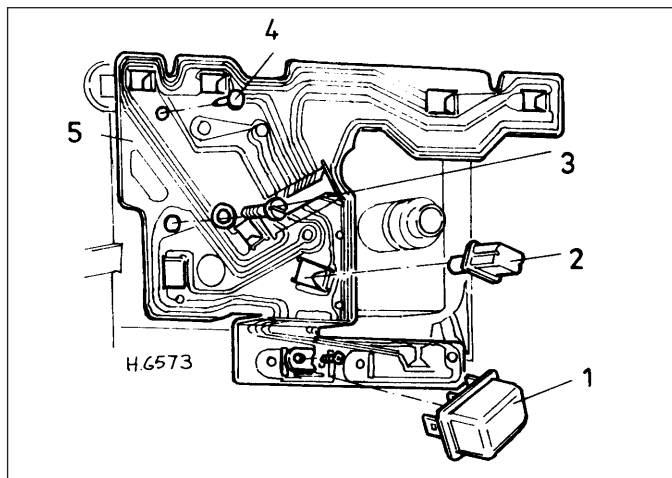

**16.9 Offset instrument panel printed circuit connections**

- |                      |  |                                 |
|----------------------|--|---------------------------------|
| 1 Voltage stabiliser | 3 Fuel and temperature gauge securing screws | 4 Printed circuit securing stud |
| 2 Panel light        | 5 Printed circuit                            |                                 |

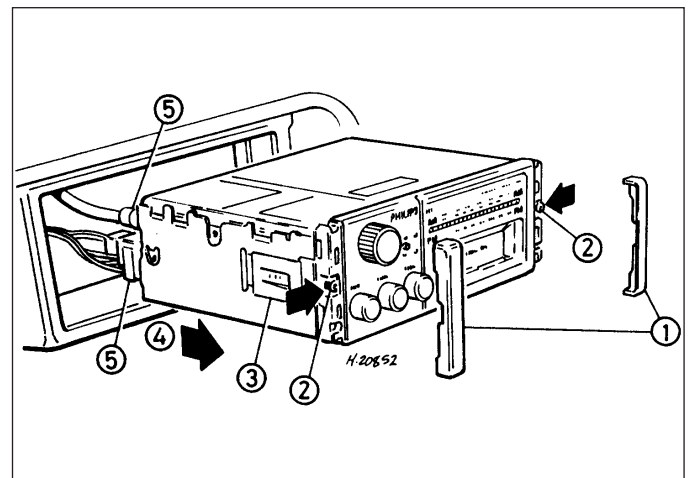

**18.4 Radio fixings on 1989-on models**

- |                    |                              |
|--------------------|------------------------------|
| 1 Side covers      | 4 Direction of removal       |
| 2 Retaining screws | 5 Multi-plug and aerial lead |
| 3 Holding clips    |                              |

**5** Press the two screws in to release the radio securing clips.

**6** Push the radio out from behind the facia, and disconnect the wiring connectors and aerial lead.

**7** Refitting is a reversal of removal, but make sure that the radio is fully engaged with the clips.

**1989 onwards models with radio in the facia**

**8** Two special DIN standard removal tools, available from in-car entertainment specialists, are required for removal.

**9** Where fitted, prise the side covers from the radio.

**10** Insert the removal tools into the holes on each side of the radio front plate, and push them in until they snap into place.

**11** Push the tools apart to depress the internal retaining clips, then pull the tools outwards to withdraw the radio.

**12** Disconnect the wiring connectors and the aerial lead from the rear of the radio. Release the removal tools.

**13** To refit, reconnect the wiring and aerial lead, push the radio into its aperture until the retaining clips engage and, where applicable, refit the side covers.

**Refitting**

**14** Refitting is the reverse sequence to removal. Where applicable, re-activate the security code on completion.

**19 Anti-theft alarm system components - removal and refitting**

**Removal**

**Electronic control unit (ECU)**

**1** On models fitted with a wooden facia, remove the facia as described in Chapter 11.

**2** On models without a wooden facia, remove the left-hand fresh air vent assembly as described in Chapter 3, then release the left-hand door seal weatherstrip to gain access to

the bulkhead trim. Remove the two edge clips, and peel back the bulkhead trim for access to the ECU.

**3** On all models, undo the two ECU retaining screws and disconnect the wiring multiplugs.

**4** Cut the cable-ties to release the receiver lead, and remove the ECU.

**Bonnet switch**

**5** Open the bonnet, and undo the screw securing the switch to the front panel.

**6** Lift off the switch and disconnect the wiring.

**Boot switch**

**7** Open the boot, and disconnect the wiring from the switch.

**8** Undo the switch retaining screw, and remove the switch from its bracket.

**Refitting**

**9** Refitting is the reverse sequence to removal. Secure the receiver lead with new cable-ties when refitting the ECU.

**Key to wiring diagrams 1 to 9 inclusive**

*Some of the components listed in this key may not be fitted to individual models*

1	Dynamo or alternator	30	RH rear flasher light	95	Tachometer
2	Control box	31	LH rear flasher light	110	RH repeater flasher
3	Battery (12 volt)	32	Heater or fresh-air blower switch	111	LH repeater flasher
4	Starter solenoid	33	Heater or fresh-air blower	115	Rear window demister switch
5	Starter motor	34	Fuel gauge	116	Rear window demister unit
6	Lighting switch	35	Fuel gauge tank unit	139	Alternative connections for two-speed wiper motor and switch
7	Headlight dip switch	36	Windscreen wiper switch	150	Rear window demist warning light
8	RH headlight	37	Windscreen wiper motor	152	Hazard warning light
9	LH headlight	38	Ignition/starter switch	153	Hazard warning switch
10	Main beam warning light	39	Ignition coil	154	Hazard warning flasher unit
11	RH sidelight/parking light	40	Distributor	158	Printed circuit instrument panel
12	LH sidelight/parking light	41	Fuel pump	159	Brake pressure warning light and light test switch
14	Panel lights	42	Oil pressure switch	160	Brake pressure failure switch
15	Number plate light(s)	43	Oil pressure gauge or warning light	164	Ballast resistor
16	RH stop and tail light	44	Ignition warning light	168	Ignition key audible warning buzzer
17	LH stop and tail light	45	Speedometer (headlight flasher switch on Canadian Mini 1000)	170	RH front side marker light
18	Stop light switch	46	Water temperature gauge	171	LH front side marker light
19	Fuse block	47	Water temperature transmitter	172	RH rear side marker light
20	Interior light	49	Reversing light switch	173	LH rear side marker light
21	RH door switch(es)	50	Reversing light	198	Driver's seat belt switch
22	LH door switch(es)	64	Bi-metallic instrument voltage stabiliser	199	Passenger's seat belt switch
23	Horn(s)	67	Line fuse (35 amp)	200	Passenger's seat switch
24	Horn push	75	Automatic transmission inhibitor switch (when fitted)	201	Seat belt warning gearbox switch
25	Flasher unit	77	Windscreen washer motor	202	Seat belt warning light
26	Direction indicator headlight flasher and dip switch	78	Windscreen washer switch	203	Seat belt warning code
27	Direction indicator warning light(s)	83	Induction heater and thermostat		
28	RH front flasher light	84	Suction chamber heater		
29	LH front flasher light				

**Cable colour code**

B	Black	N	Brown	U	Blue
G	Green	O	Orange	W	White
K	Pink	P	Purple	Y	Yellow
LG	Light Green	R	Red		

When a cable has two colour code letters the first denotes the main colour and the second denotes the tracer colour





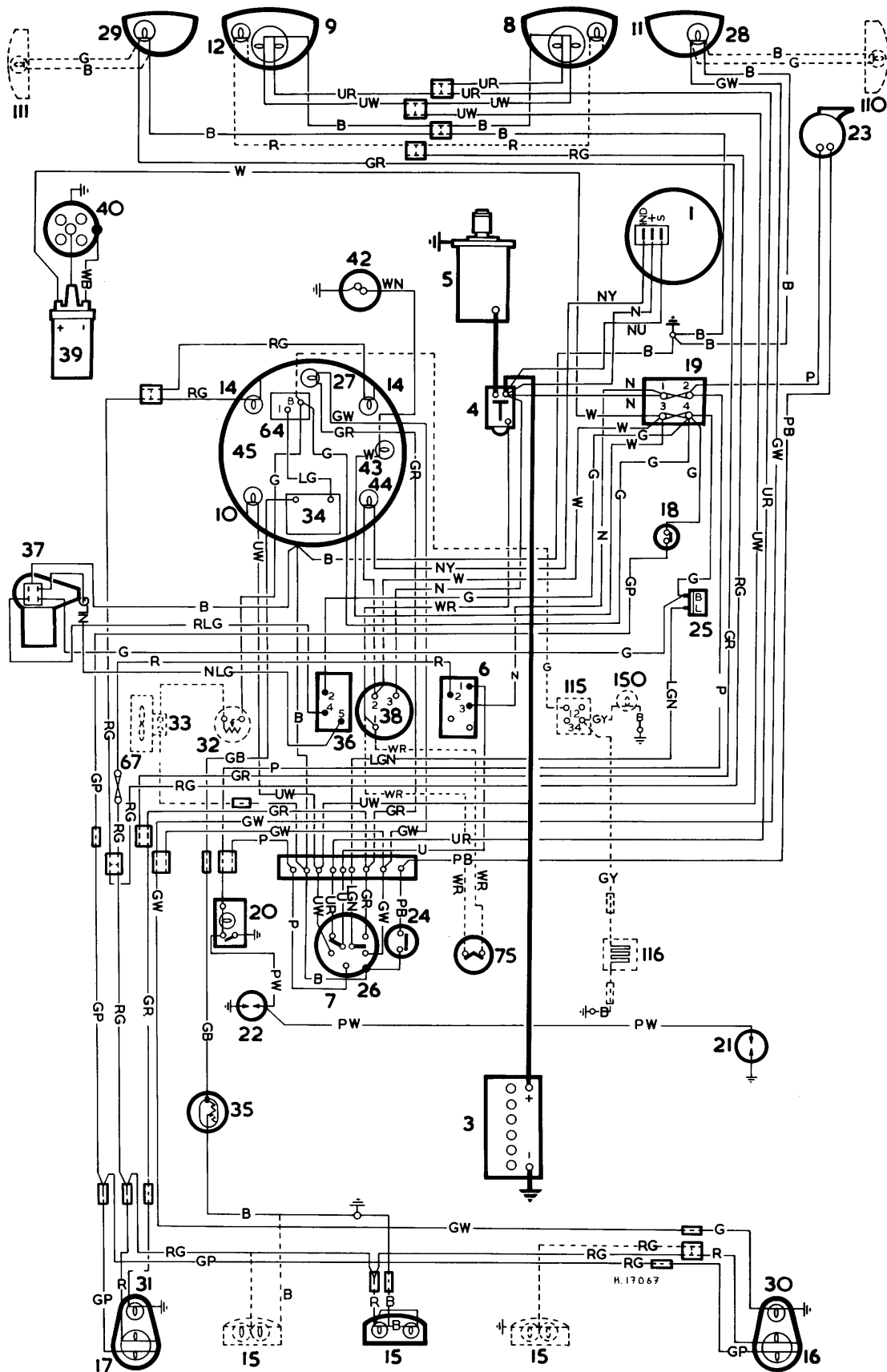

Wiring diagram 2 - Mini 850 De Luxe Saloon, Van and Pick-up (with alternator and rocker type switches) - pre 1976

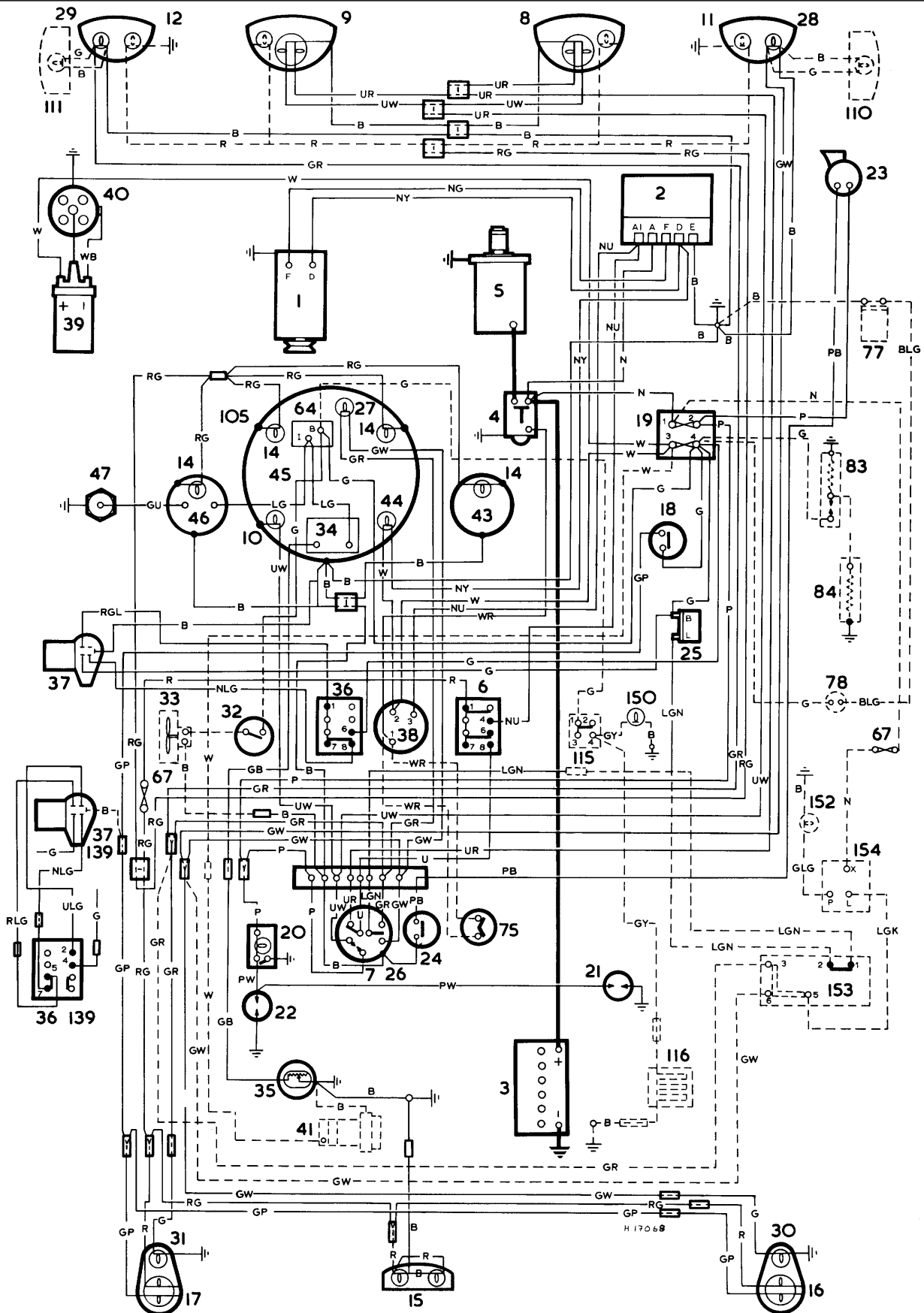

Wiring diagram 3 - Mini 1000 Special De Luxe Saloon and Cooper S Mk III (with dynamo and toggle type switches)

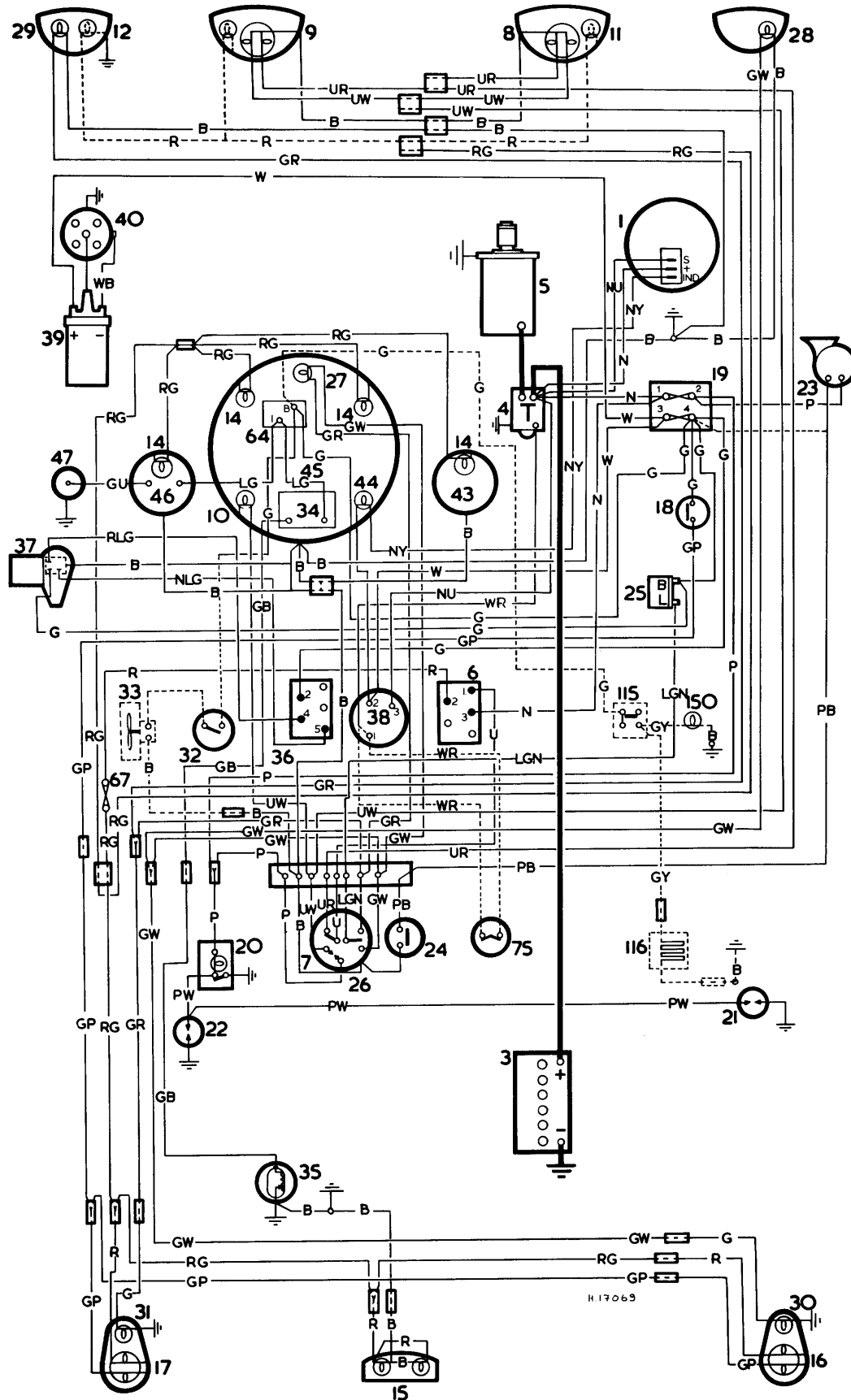

Wiring diagram 4 - Mini 1000 Special De Luxe Saloon (with alternator and rocker type switches) - pre 1976



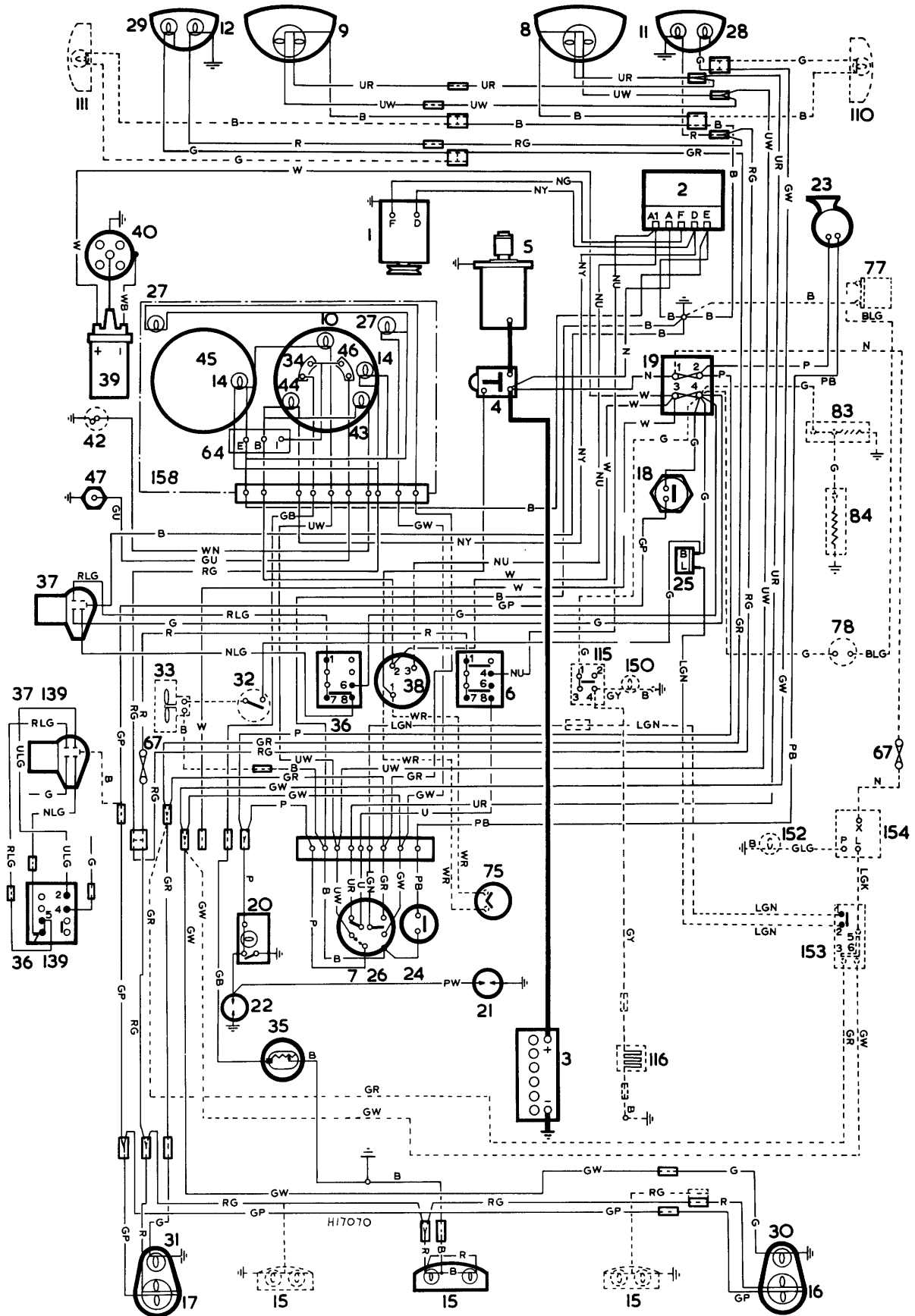

Wiring diagram 5 - Mini Clubman Saloon and Estate (with dynamo and toggle type switches)

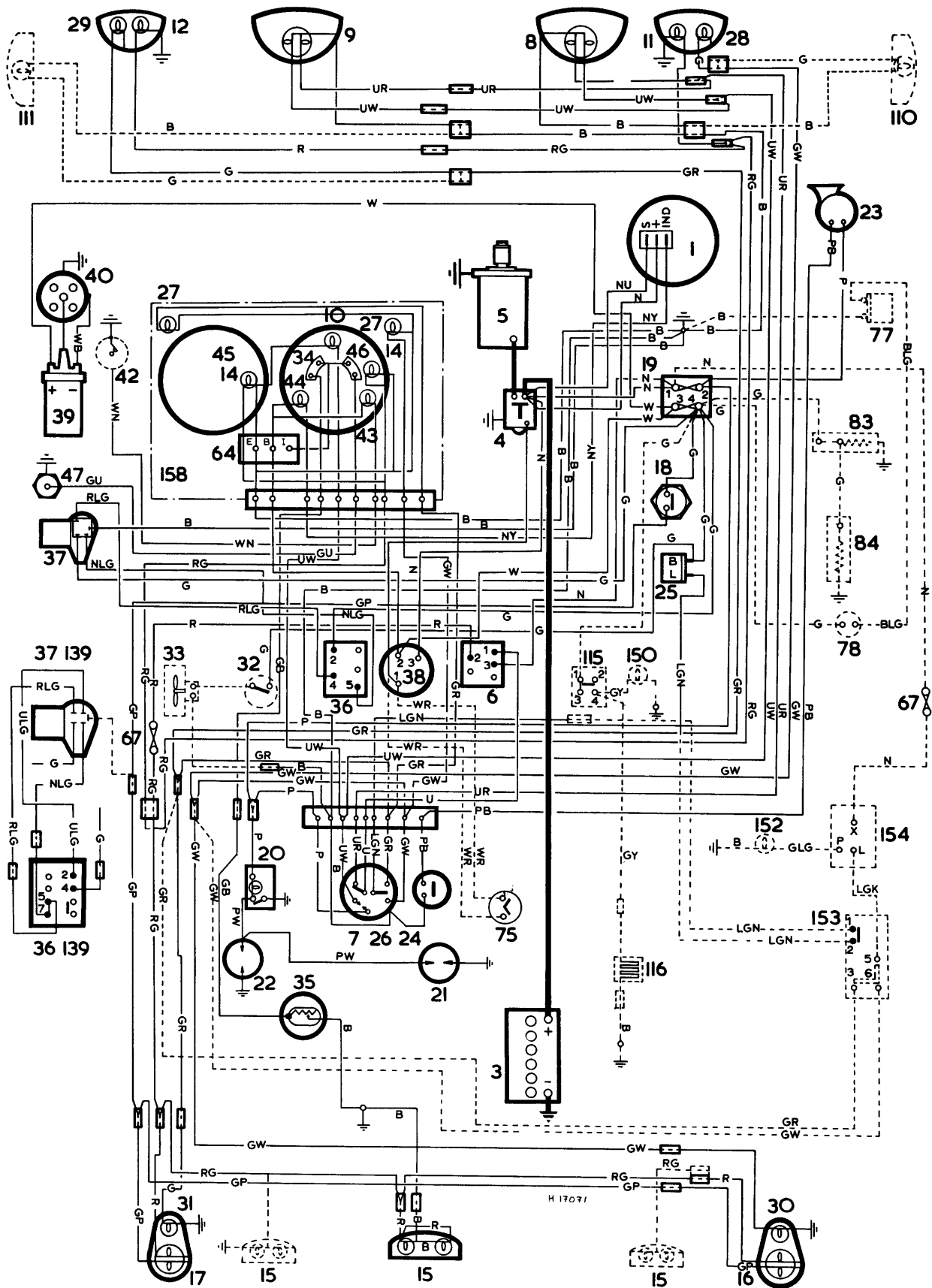

Wiring diagram 6 - Mini Clubman Saloon and Estate (with alternator and rocker type switches) - pre 1976

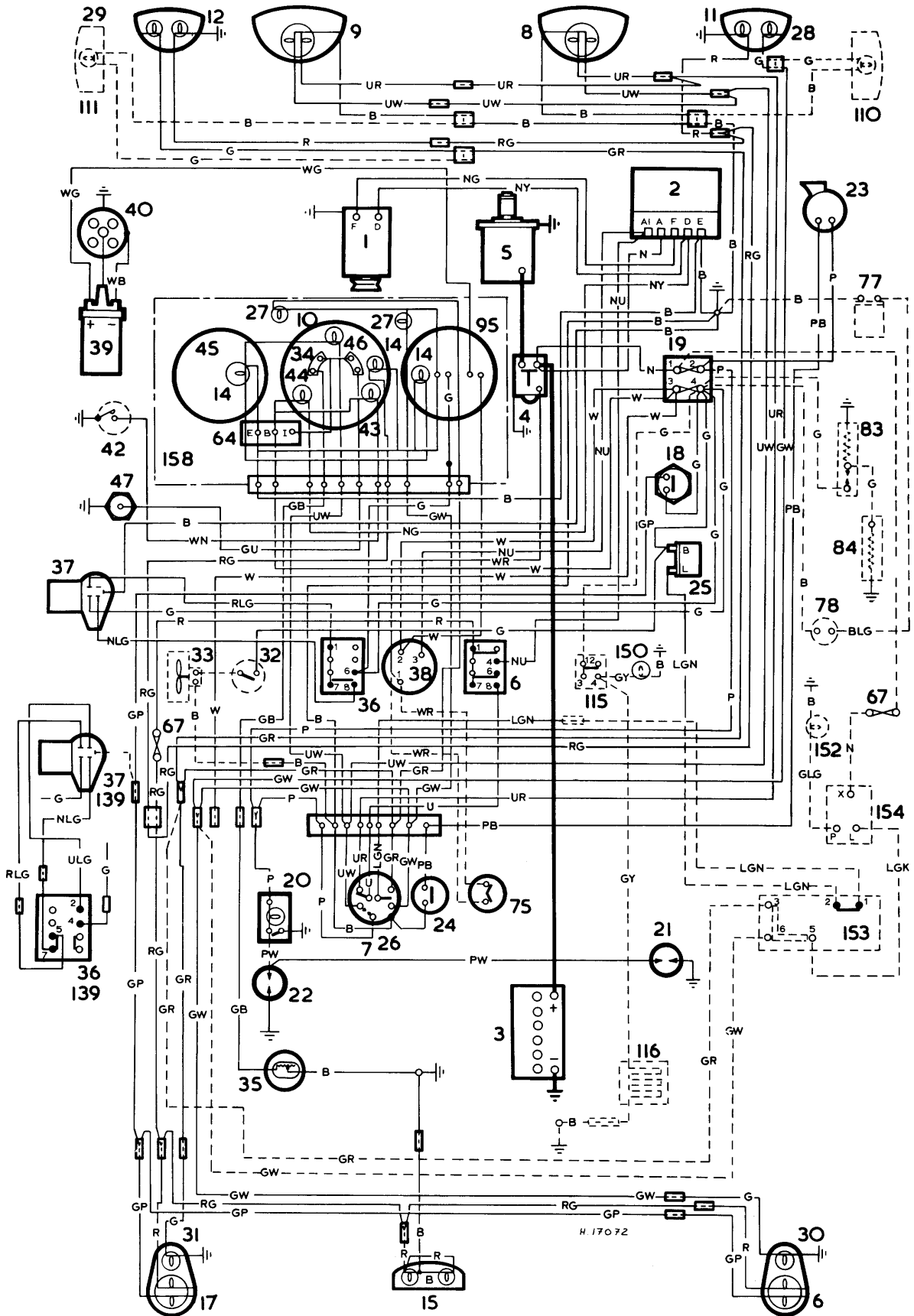

Wiring diagram 7 - Mini 1275 GT (with dynamo and toggle type switches)

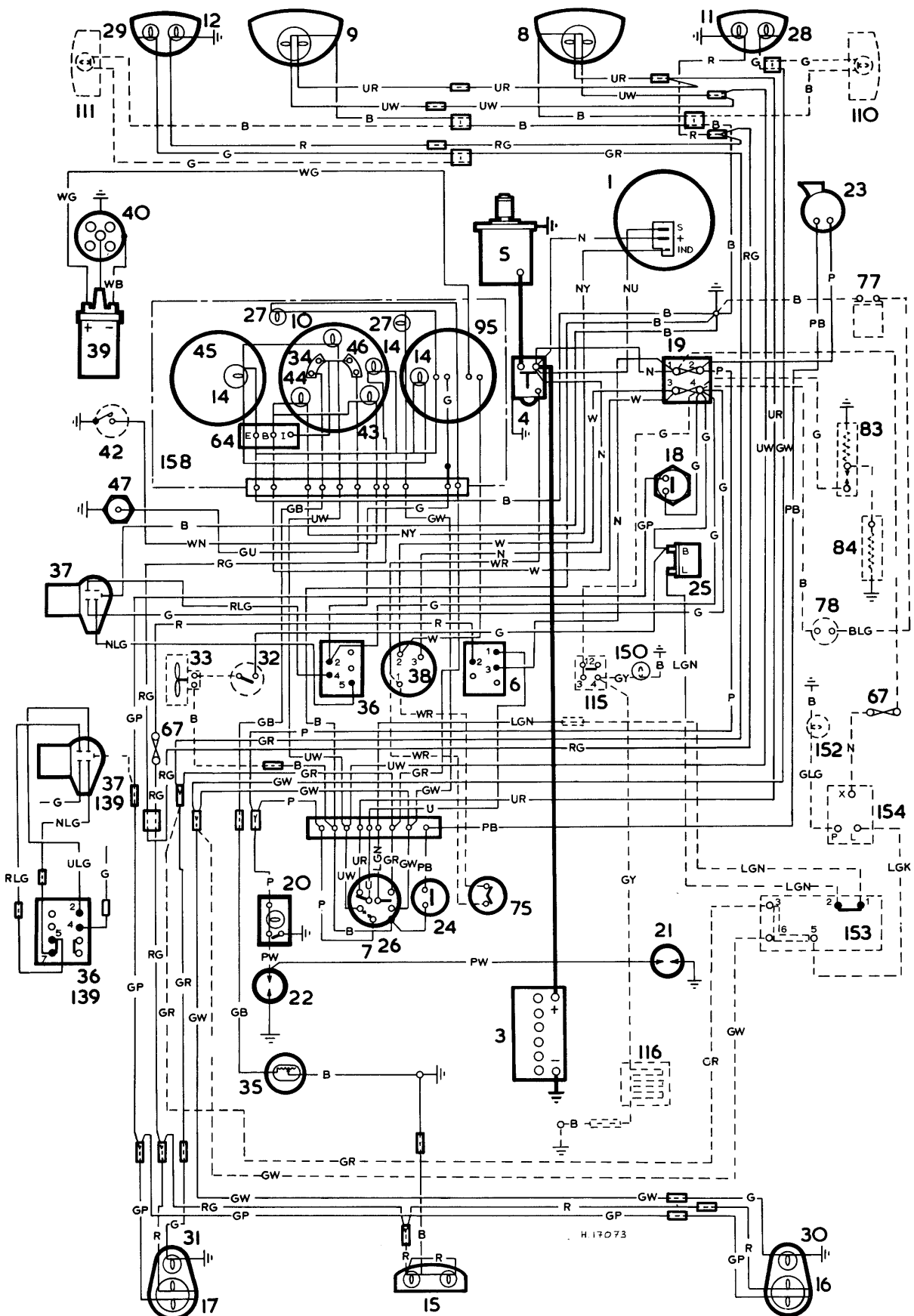

Wiring diagram 8 - Mini 1275 GT (with alternator and rocker type switches) - pre 1976



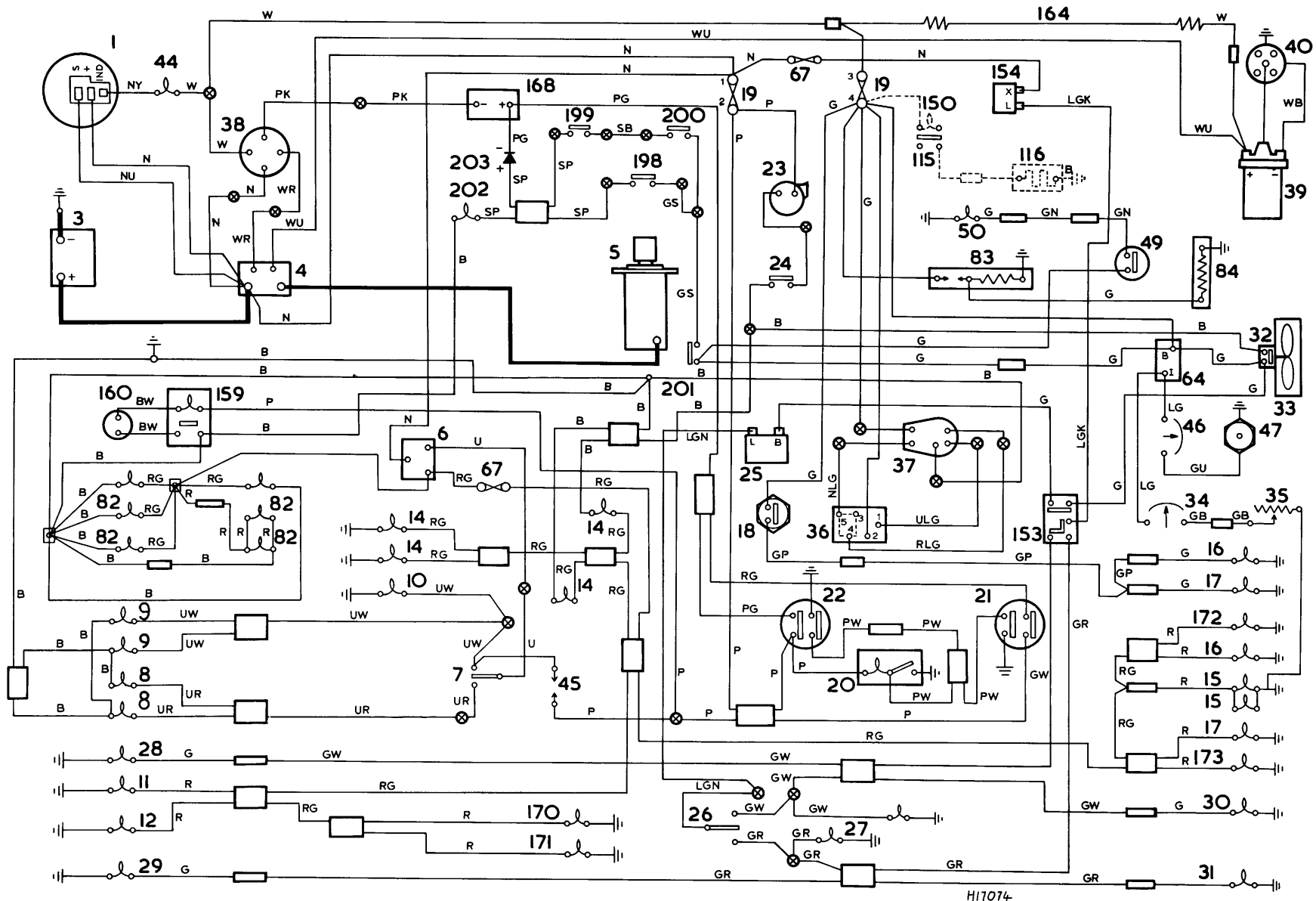

Wiring diagram 9 - Mini 1000 Saloon (Canada) - pre 1977

**Key to wiring diagrams 10 to 15 inclusive***Some of the components listed in this key may not be fitted to individual models*

1	Alternator	34	Fuel level indicator	152	Hazard warning light
3	Battery	35	Fuel level indicator tank unit	153	Hazard warning switch
4	Starter solenoid	37	Windscreen wiper motor	154	Hazard warning flasher unit
5	Starter motor	38	Ignition switch	158	Printed circuit instrument panel
6	Lighting switch	39	Ignition coil	159	Brake failure test switch and warning light
7	Headlight dip switch	40	Distributor	160	Brake pressure differential switch
8	Headlight dip beam	42	Oil pressure switch	164	Resistive cable
9	Headlight main beam	43	Oil pressure warning light	165	Handbrake switch
10	Main beam warning light	44	No charge warning light	166	Handbrake warning light
11	Sidelight - RH	45	Headlight flasher switch	168	Ignition key warning buzzer
12	Sidelight - LH	46	Water temperature indicator	169	Buzzer door switch
14	Panel illumination lights	47	Water temperature transmitter	170	RH front side marker light
15	Number plate illumination lights	49	Reversing light switch	171	LH front side marker light
16	Stop lights	50	Reversing light	172	RH rear side marker light
17	Tail light - RH	56	Clock (if fitted)	173	LH rear side marker light
18	Stop light switch (hydraulic)	57	Cigar lighter (if fitted)	198	Driver's seat belt switch
18	Stop light switch (mechanical)	60	Radio	199	Passenger's seat belt switch
19	Fuse box	64	Voltage stabiliser	200	Passenger seat switch
20	Interior light	67	Line fuse	201	Seat belt warning gearbox switch
21	Interior light switch (door)	75	Automatic transmission inhibitor switch	202	Seat belt warning light
22	Tail light - LH	77	Windscreen washer motor	203	Blocking diode - seat belt warning
23	Horn	82	Switch illumination light	208	Cigar lighter illumination
24	Horn-push	83	Induction heater and thermostat	210	Panel illumination rheostat
25	Indicator flasher unit	84	Suction chamber heater	211	Heater control illumination
26	Indicator switch	95	Tachometer	286	Rear fog guard switch
27	Indicator warning light	110	Indicator repeater lights	287	Rear fog guard warning light
28	Front indicator light - RH	115	Heated rear screen switch	288	Rear fog guard light
29	Front indicator light - LH	116	Heated rear screen	291	Brake warning relay
30	Rear indicator light - RH	118	Combined windscreen washer and wiper switch	314	Clock illumination
31	Rear indicator light - LH				
32	Heater switch	132	Brake warning light		
33	Heater motor	150	Heated rear screen warning light		

**Cable colour code**

B	Black	N	Brown	U	Blue
G	Green	O	Orange	W	White
K	Pink	P	Purple	Y	Yellow
LG	Light Green	R	Red		

*When a cable has two colour code letters the first denotes the main colour and the second denotes the tracer colour.*

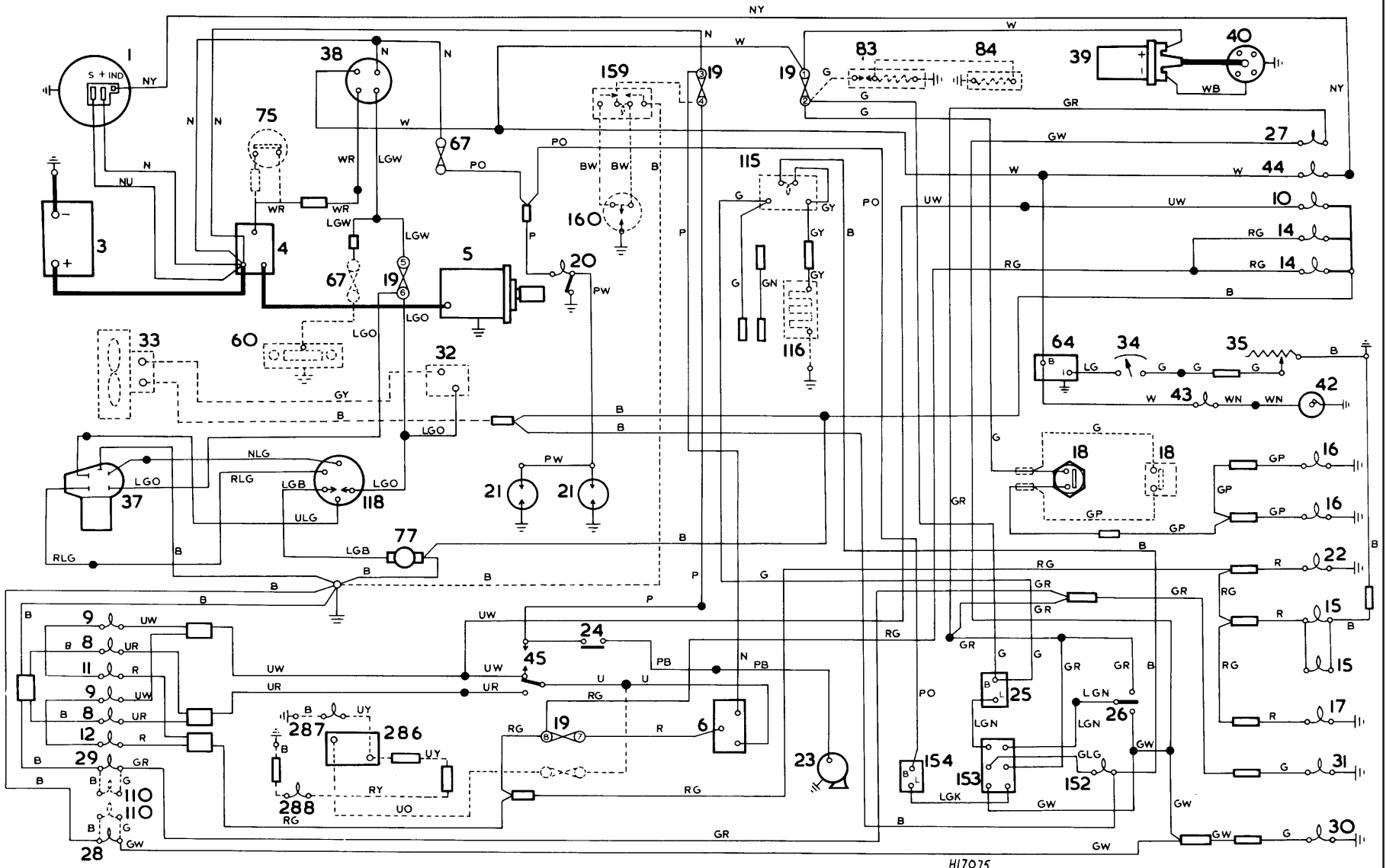

Wiring diagram 10 - Mini 850 Saloon, Van and Pick-up - 1976 onwards

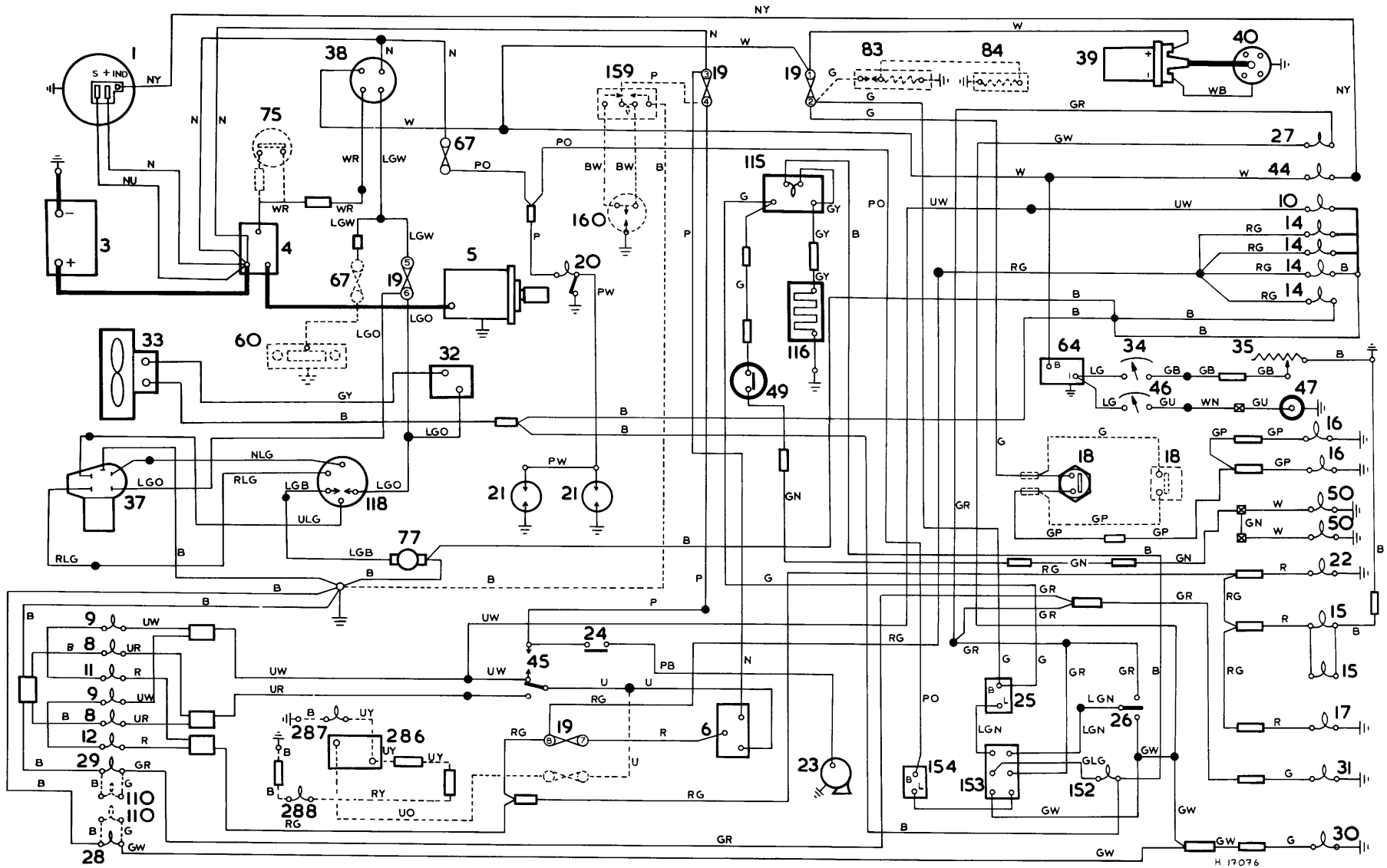

Wiring diagram 11 - Mini 1000 Saloon (triple instrument facia) - 1976 onwards (UK, Europe, Sweden); and Mini Special (triple instrument facia) - 1976 to 77



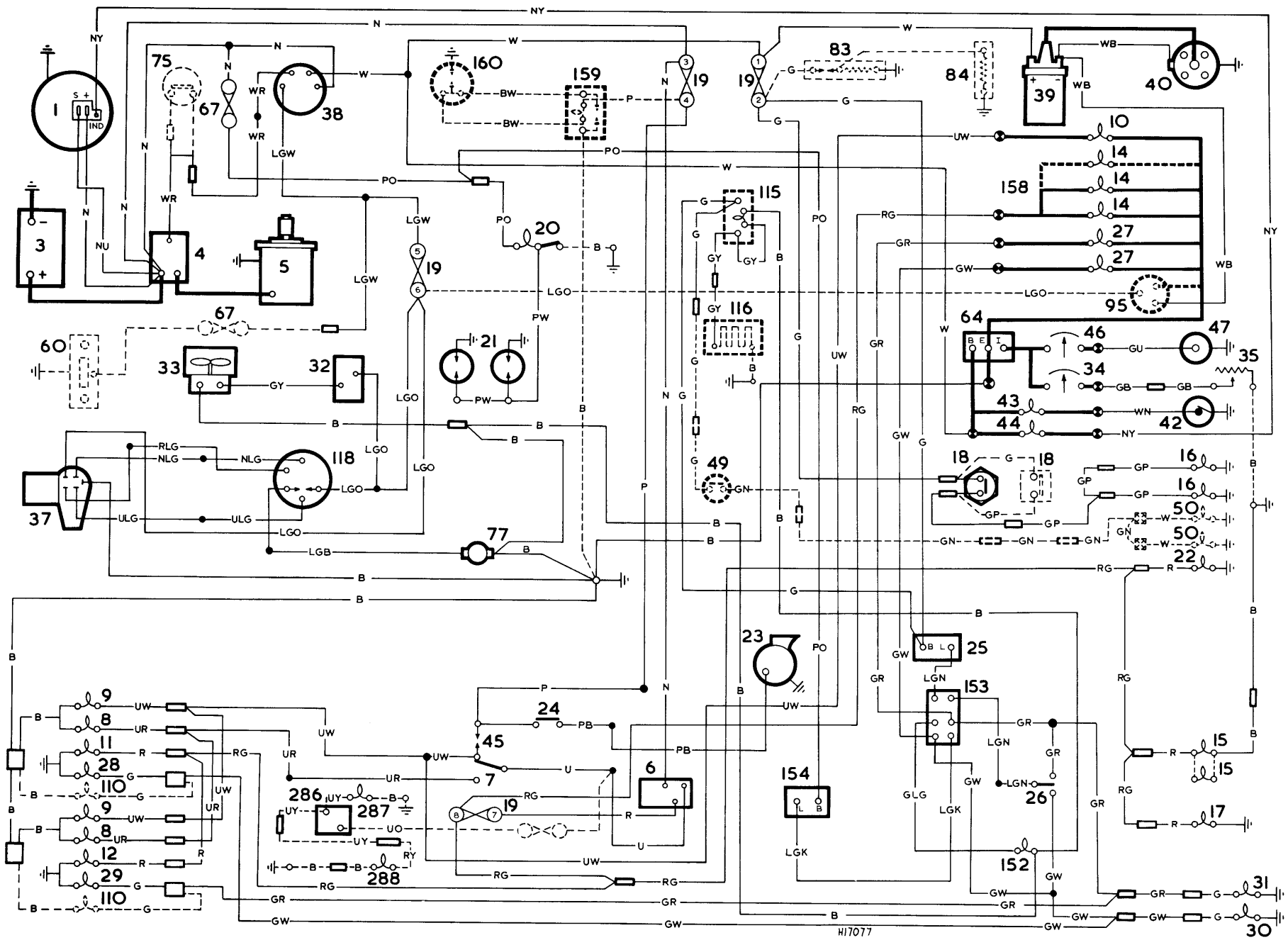

Wiring diagram 12 - Mini Clubman, Estate and 1275 GT - 1976 onwards

H17077

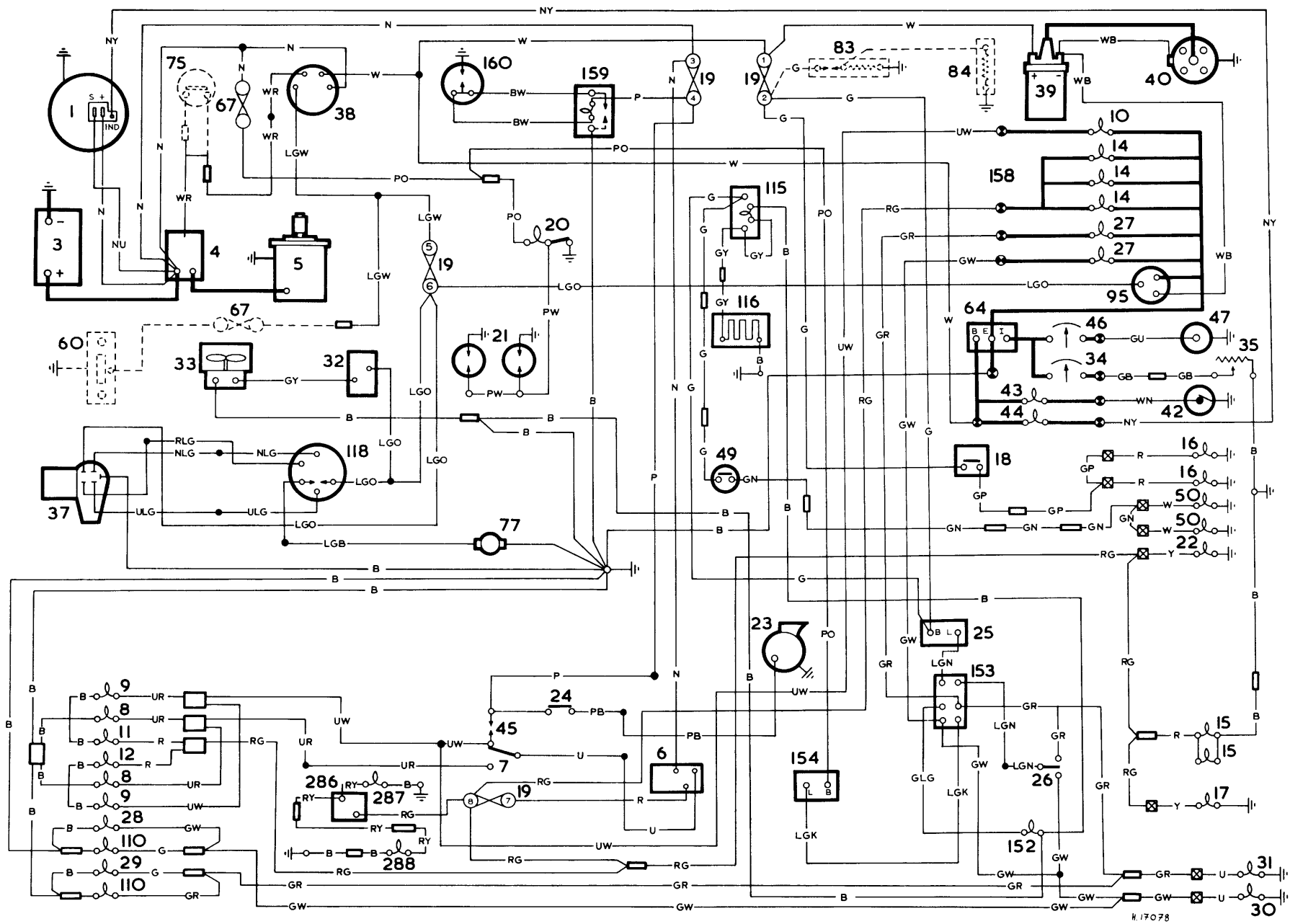

Wiring diagram 13 - Mini Special - 1977 to 78

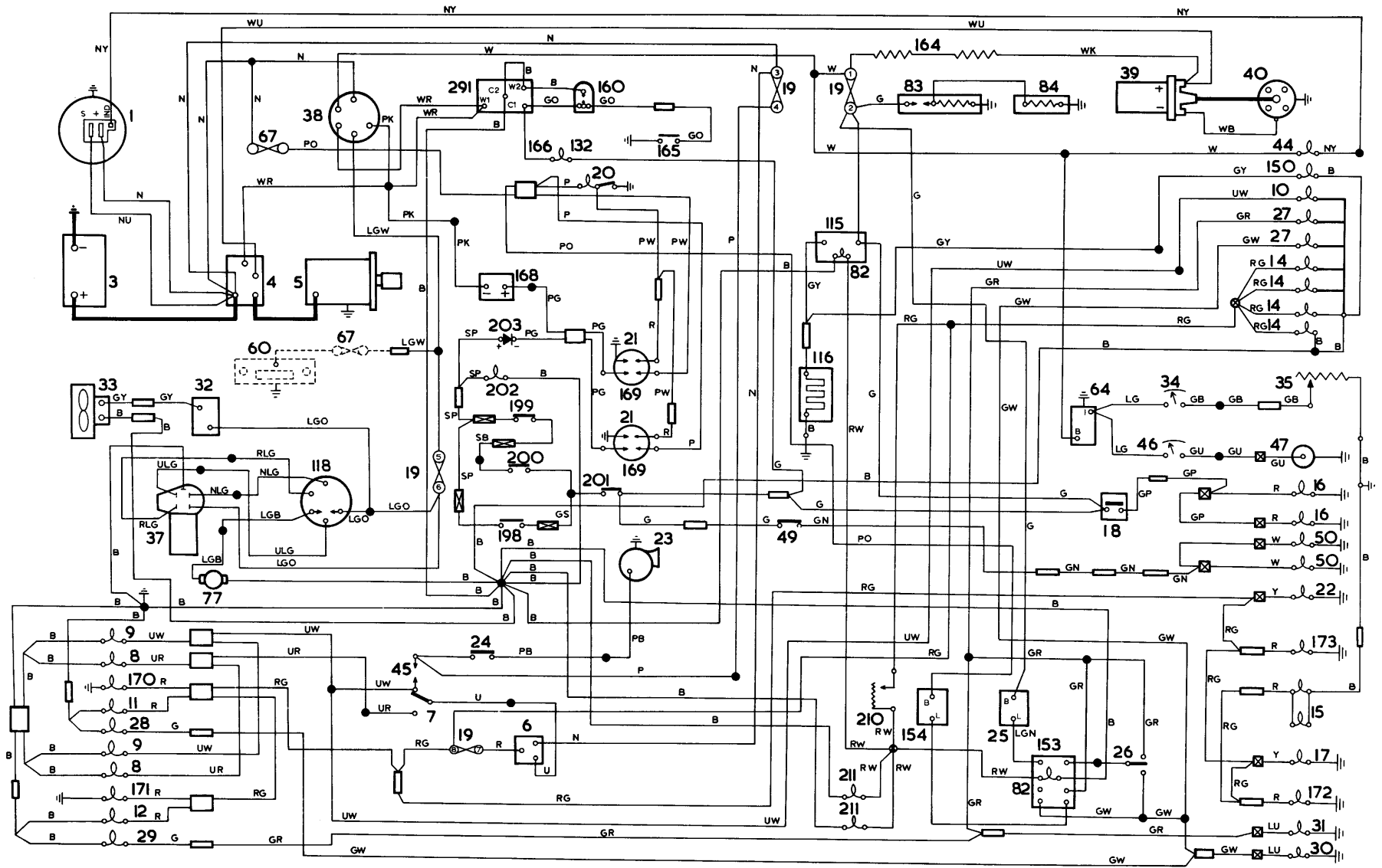

H17079

Wiring diagram 14 - Mini 1000 (Canada) - 1977 onwards

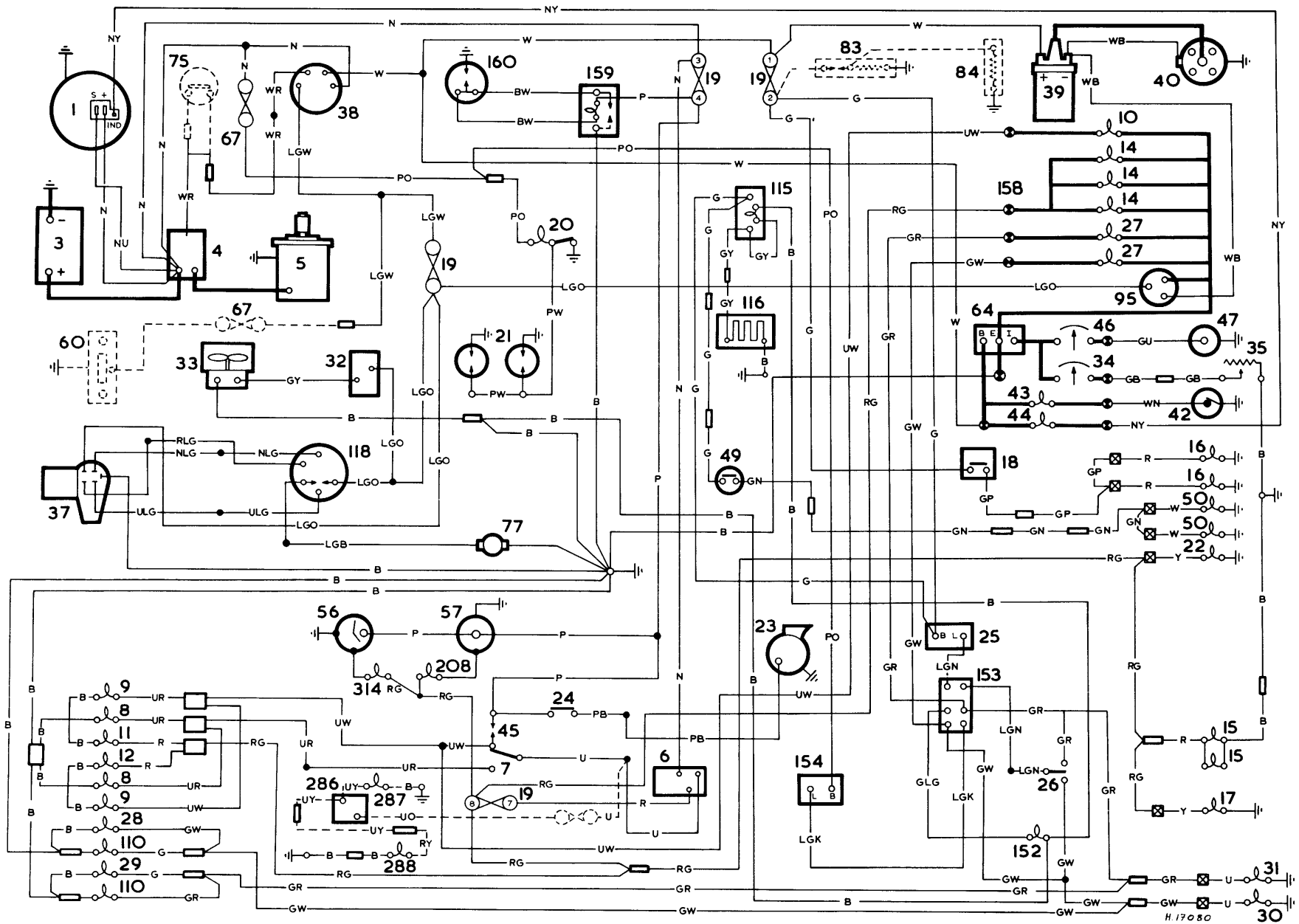

Wiring diagram 15 - Mini Special - 1979 onwards



## Master key to wiring diagrams 16 and 17

<b>No</b>	<b>Description</b>	<b>No</b>	<b>Description</b>
1	Alternator	35	Ignition/start switch
2	Battery	36	Ignition coil
3	Starter motor solenoid	37	Distributor
4	Starter motor	38	Oil pressure switch
5	Lighting switch	39	Oil pressure warning light
6	Headlight dip switch	40	No charge warning light
7	Headlight dip beam	41	Headlight flash switch
8	Headlight main beam	42	Water temperature indicator (when fitted)
9	Main beam warning light	43	Water temperature transmitter (when fitted)
10	Sidelight RH	44	Reverse light switch
11	Sidelight LH	45	Reverse light
12	Panel illumination lights	46	Radio (when fitted)
13	Number plate illumination lights	47	Voltage stabiliser
14	Stop-lights	48	Line fuse
15	Tail-lights RH	49	Automatic transmission starter inhibitor switch (when fitted)
16	Stop-light switch (mechanical)	50	Windscreen washer motor
17	Fusebox	51	Induction heater and thermostat (when fitted)
18	Interior light	52	Carburettor dashpot heater (when fitted)
19	Interior light switch (door)	53	Tachometer (when fitted)
20	Tail light LH	54	Direction indicator repeater lights (when fitted)
21	Horn	55	Heated rear screen switch
22	Horn push	56	Heated rear screen
23	Direction indicator flasher unit	57	Combined windscreen washer and wiper switch
24	Direction indicator switch	58	Hazard warning light
25	Direction indicator warning light	59	Hazard warning switch
26	Front direction indicator light - RH	60	Hazard warning flasher unit
27	Front direction indicator light LH	61	Printed circuit instrument panel
28	Rear direction indicator light - RH	62	Brake low fluid level warning light and test switch
29	Rear direction indicator light LH	63	Ballast resistor (cable)
30	Heater switch	64	Rear fog-guard switch
31	Heater motor	65	Rear fog-guard warning light
32	Fuel level indicator	66	Rear fog-guard light
33	Fuel level indicator tank unit	67	Brake fluid level sensor switch
34	Windscreen wiper motor	68	Speakers (when fitted)

## Cable colour code

BL	Blue	GR	Slate	PU	Purple
BK	Black	LG	Light green	R	Red
BR	Brown	O	Orange	W	White
G	Green	P	Pink	Y	Yellow

When a cable has two colour code letters, the first denotes the main colour and the second denotes the tracer colour

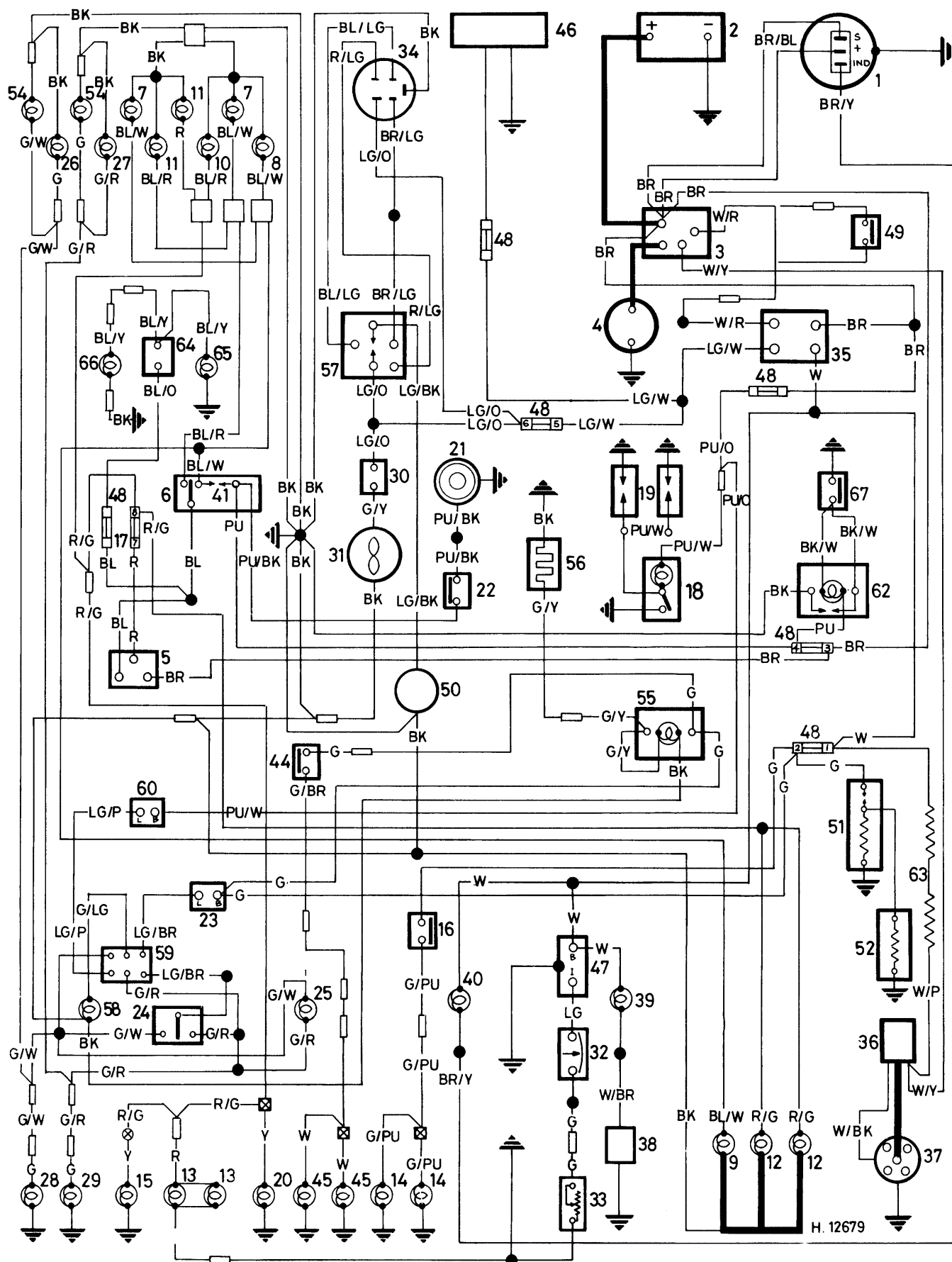

Wiring diagram 16 - all 1984-on carburettor models with single instrument pack

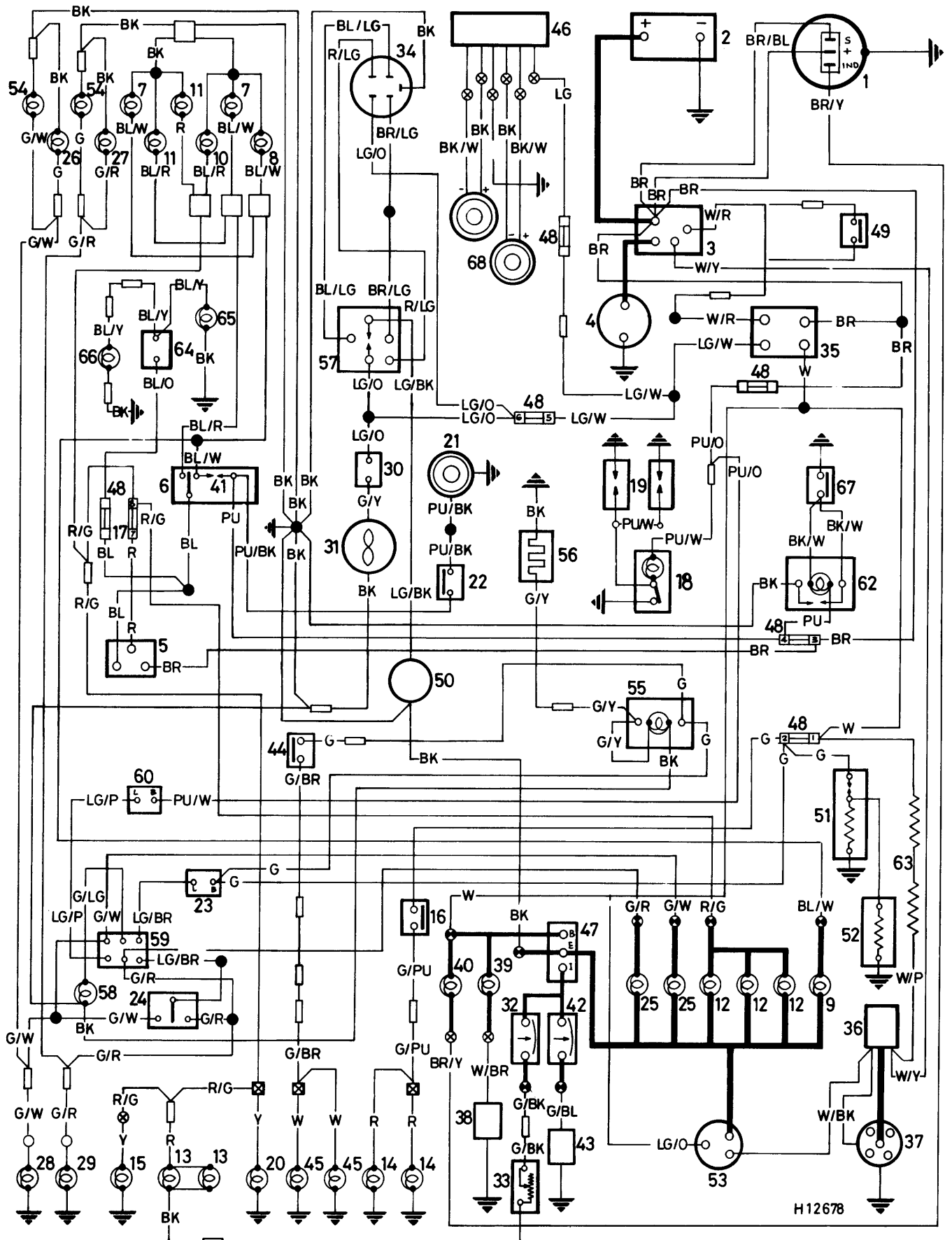

Wiring diagram 17 - all 1984-on carburettor models with multiple instrument pack

## Key to wiring diagram 18



No	Description	No	Description
1	Direction indicator unit	40	Main beam warning light
2	Direction indicator switch	41	Coolant temperature gauge
3	Hazard warning switch	42	Fuel gauge
4	Hazard warning unit	43	Rear foglight warning light
5	Hazard warning light	44	Panel lights
6	RH front direction indicator	45	Heater switch
7	RH side repeater light	46	Horn switch
8	RH rear direction indicator	47	Voltage stabiliser
9	LH front direction indicator	48	Battery
10	LH side repeater light	49	Lighting switch
11	LH rear direction indicator	50	Headlight dipswitch
12	Automatic transmission starter inhibitor switch	51	Number plate illumination lights
13	Distributor	52	RH tail light
14	Ignition coil	53	LH tail light
15	Starter relay	54	Horn
16	Ignition switch	55	Windscreen wiper motor
17	Starter motor solenoid	56	Headlight flasher switch
18	Ballast resistor	57	Rear foglight switch
19	In-line fuse	58	Windscreen washer motor
20	Fuse block	59	Heated rear window element
21	Stop-light switch	60	LH front door switch
22	Dim/dip resistor	61	Wash/wipe switch
23	Heated rear window switch	62	Alternator
24	Heater motor	63	Coolant thermistor
25	Reversing light switch	64	Oil pressure switch
26	Interior light	65	Brake fluid level switch
27	RH front door switch	66	Oil pressure warning light
28	Fuel tank sender unit	67	Tachometer
29	Radio - single speaker	68	RH/single door speaker
30	Radio/cassette player	69	LH front door speaker
31	RH stop light	70	LH stop light
32	RH sidelight	71	Rear foglight
33	LH sidelight	72	Dim/dip relay
34	Headlight main beam	73	LH reversing light
35	Headlight dip beam	74	RH reversing light
36	Brake failure light test switch	75	Emission control valve switch
37	Ignition warning light	76	Heated rear window warning light
38	LH indicator warning light	77	Vacuum solenoid valve
39	RH indicator warning light		

## Cable colour code

BK	Black	O	Orange
BL	Blue	P	Pink
BR	Brown	PU	Purple
G	Green	R	Red
GR	Slate	W	White
LG	Light green	Y	Yellow

When a cable has two colour code letters, the first denotes the main colour and the second the tracer

## Symbols used

			1
1	Fuse		2
2	Sealed joint		3
3	Earth connection		



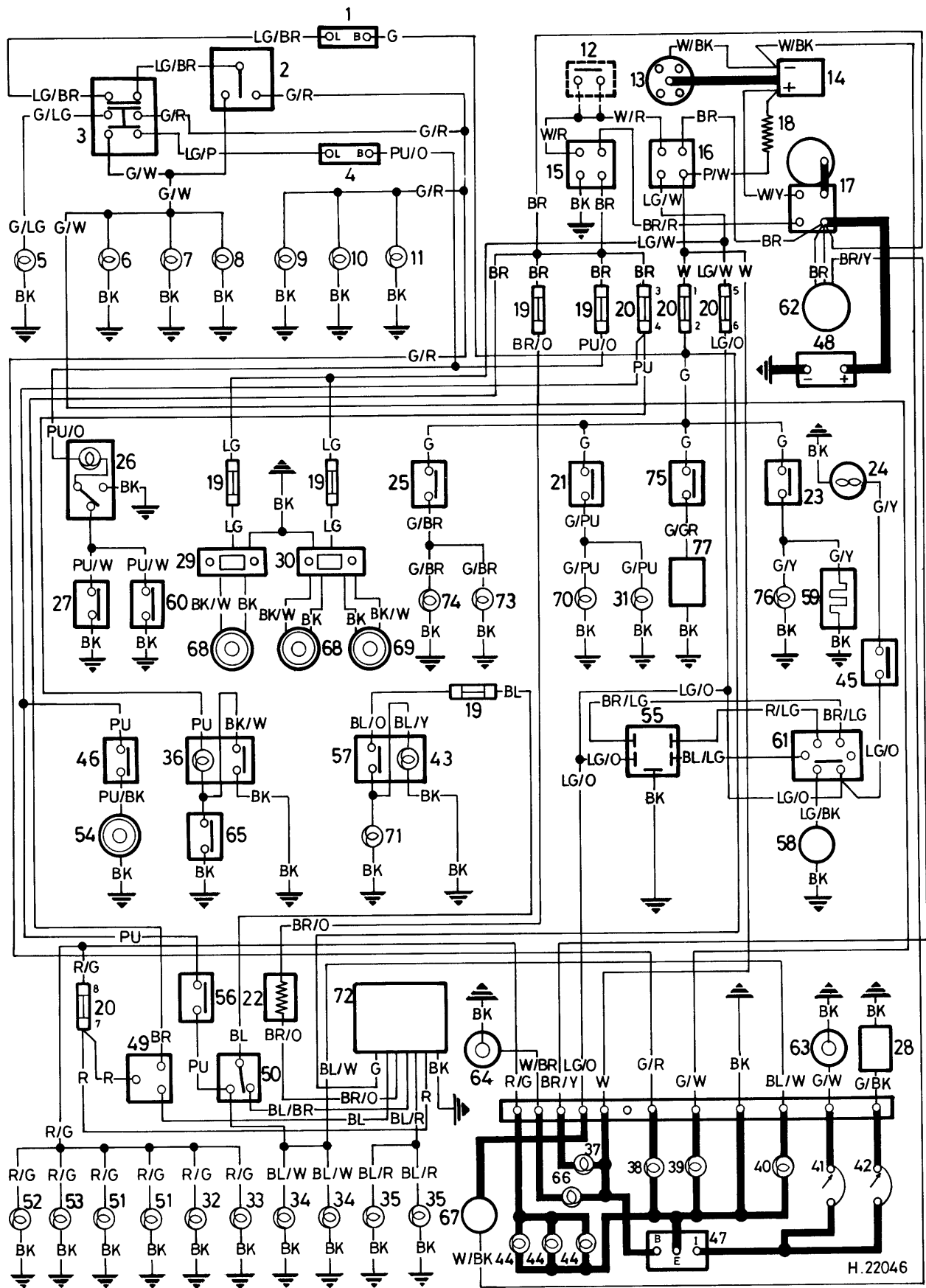

Wiring diagram 18 - 1988-on carburettor models

## Key to wiring diagrams 19 to 32 inclusive

No	Description	No	Description
1	Battery	49	Fuel sender unit
2	Lighting	50	Fuel pump
3	Dip switch	51	Relay module
4	Dipped beam headlight	52	Automatic transmission starter inhibitor switch
5	Main beam headlight	53	Accelerator pedal switch
6	RH sidelight	54	Diagnostic connector
7	LH sidelight	55	Stepper motor
8	Number plate illumination light	56	Manifold PTC heater
9	RH tail light	57	Oil pressure switch
10	Brake light switch	58	Brake fluid level switch
11	LH tail light	59	Ignition/charging warning light
12	Horn	60	Oil pressure warning light
13	Horn switch	61	Brake system warning light
14	Direction indicator switch	62	Tachometer
15	RH front direction indicator light	63	Coolant temperature gauge
16	LH front direction indicator light	64	Fuel gauge
17	Heater switch	65	Main beam warning light
18	Heater motor	66	LH indicator warning light
19	Windscreen wiper motor	67	RH indicator warning light
20	Ignition switch	68	Instrument pack
21	Headlight flasher switch	69	Intake air temperature sensor
22	Rear foglight switch	70	Interior light
23	Direction indicator/hazard warning light unit	71	Radio/cassette player
24	Automatic transmission selector indicator light	72	RH speaker
25	Windscreen washer pump	73	LH speaker
26	Heated rear window switch	74	Auxiliary cooling fan relay
27	Heated rear window element	75	LH brake light
28	Hazard warning light	76	RH brake light
29	Hazard warning light switch	77	Dim-dip relay
30	Auxiliary cooling fan	78	Instrument panel illumination
31	Purge valve	79	Distributor
32	Fusible links	80	RH rear direction indicator light
33	LH side repeater light	81	LH rear direction indicator light
34	RH side repeater light	82	Voltage stabiliser
35	Driver's door interior light switch	83	Engine management ECU
36	Passenger door interior light switch	84	Lambda sensor
37	Dim-dip resistor	85	Reversing light switch
38	Auxiliary cooling fan switch	86	Rear foglight
39	Alternator	87	Fuel injector
40	Starter relay	88	Wiper column switch
41	Ignition coil	89	Starter
42	Crankshaft sensor	90	Lambda sensor relay
43	Throttle potentiometer	91	Reversing lights
44	Coolant temperature sensor	92	Direction indicator relay
45	Fuel pump relay	93	Fuse
46	Main relay	94	Line fuse
47	Manifold PTC heater relay	95	Radio fuse
48	Inertia switch		

## Cable colour code

BL	Blue	O	Orange
BK	Black	P	Pink
BR	Brown	PU	Purple
G	Green	R	Red
GR	Slate	W	White
LG	Light green	Y	Yellow

When a cable has two colour code letters, the first denotes the main colour and the second denotes the tracer colour

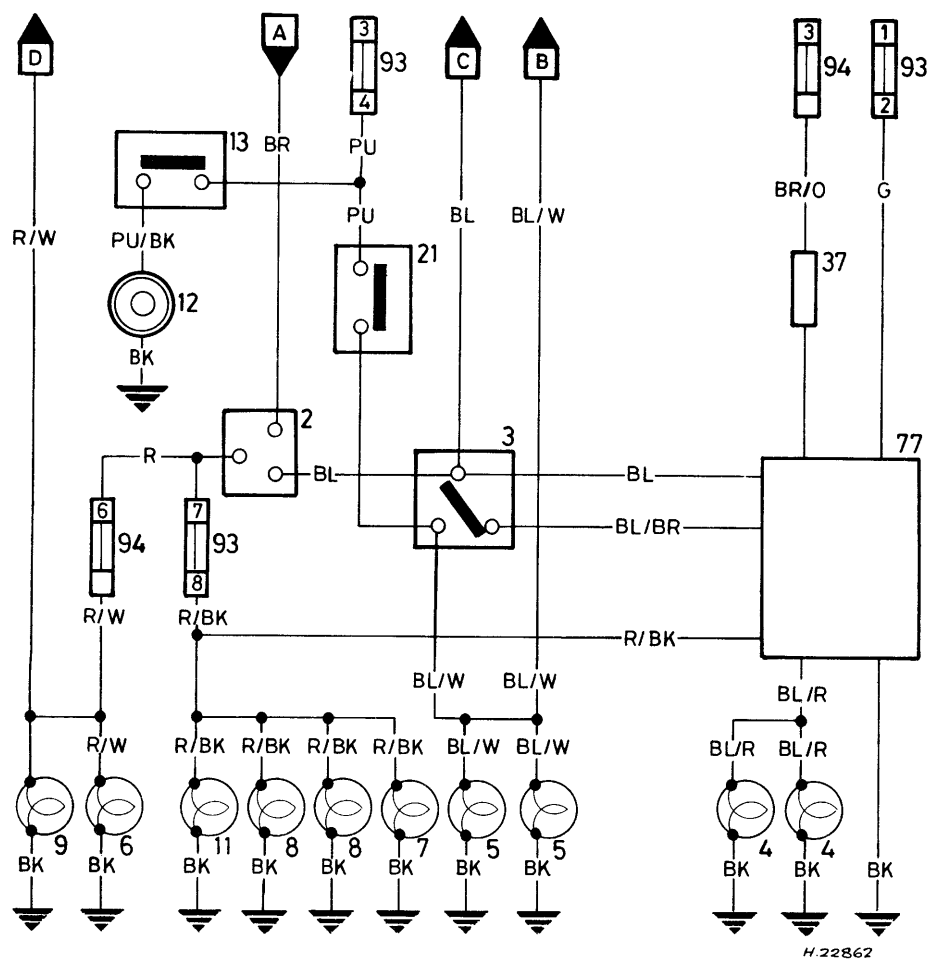

**Wiring diagram 19 - Dim-dip lighting and horn circuit (fuel-injected models)**

- A To power distribution circuit
- B To instrument circuit
- C To foglight circuit
- D To instrument circuit

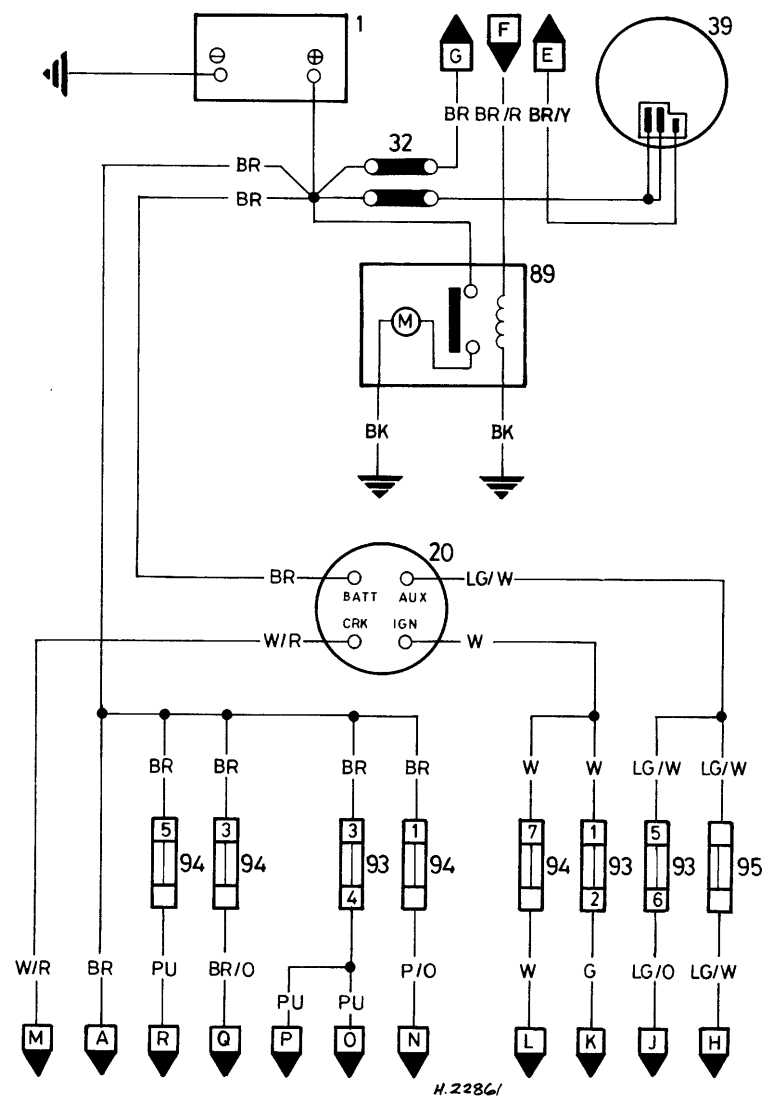

**Wiring diagram 20 - Power distribution circuit (fuel-injected models)**

- E to Wiring diagram 22
- F to Wiring diagram 21
- G to Wiring diagram 21
- H To Wiring diagram 26
- J to Wiring diagrams 22, 24, 25, 31
- K to Wiring diagrams 19, 23, 32
- L to Wiring diagrams 21, 22
- M to Wiring diagram 21
- N to Wiring diagrams 23, 28
- O to Wiring diagrams 19, 26
- P to Wiring diagram 27
- Q to Wiring diagram 27
- R to Wiring diagram 25
- A to Wiring diagram 19

H.22862

H.22861

83

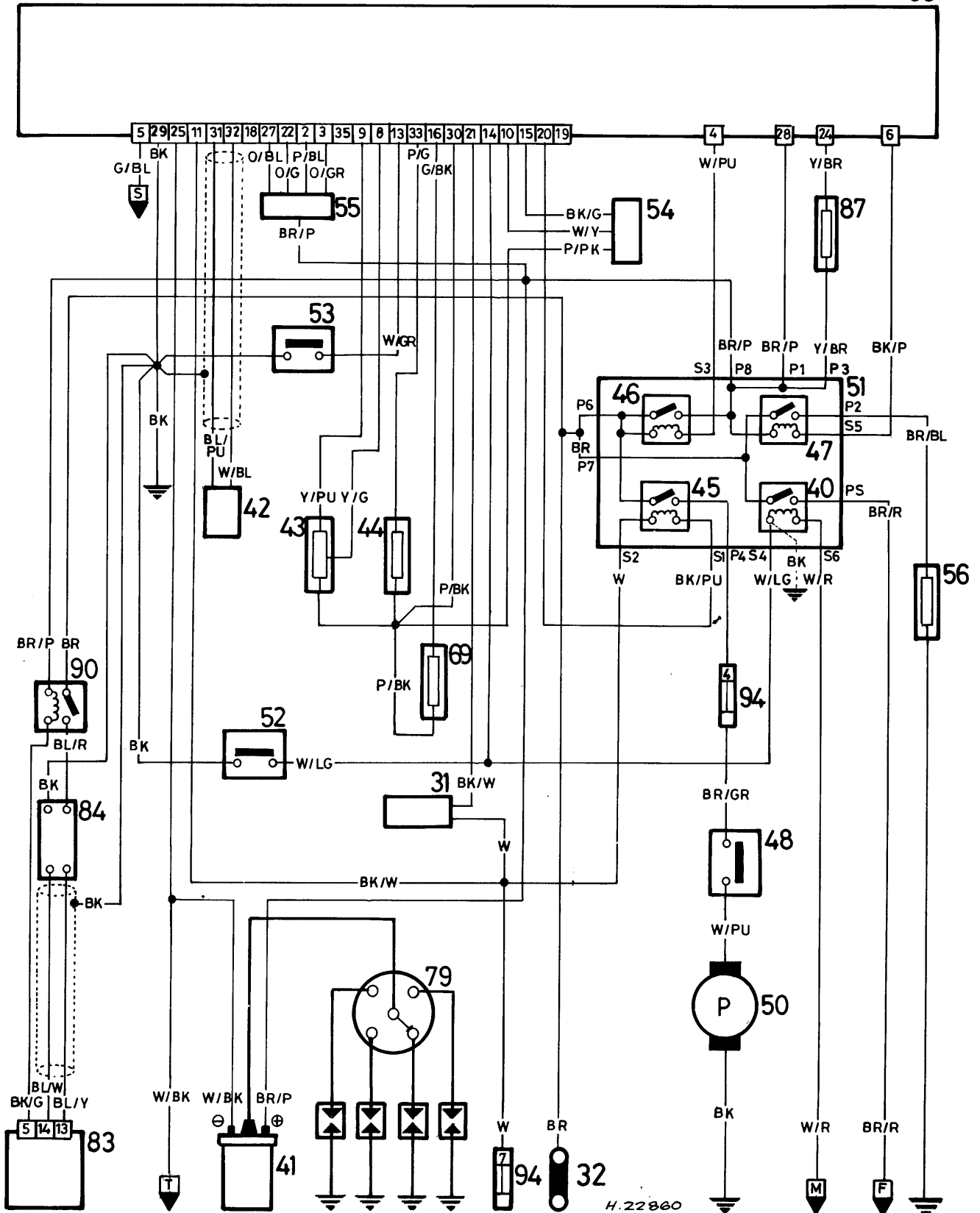

Wiring diagram 21 - Engine management circuit (fuel-injected models)

F to Wiring diagram 20  
M to Wiring diagram 20

S to Wiring diagram 22  
T to Wiring diagram 22



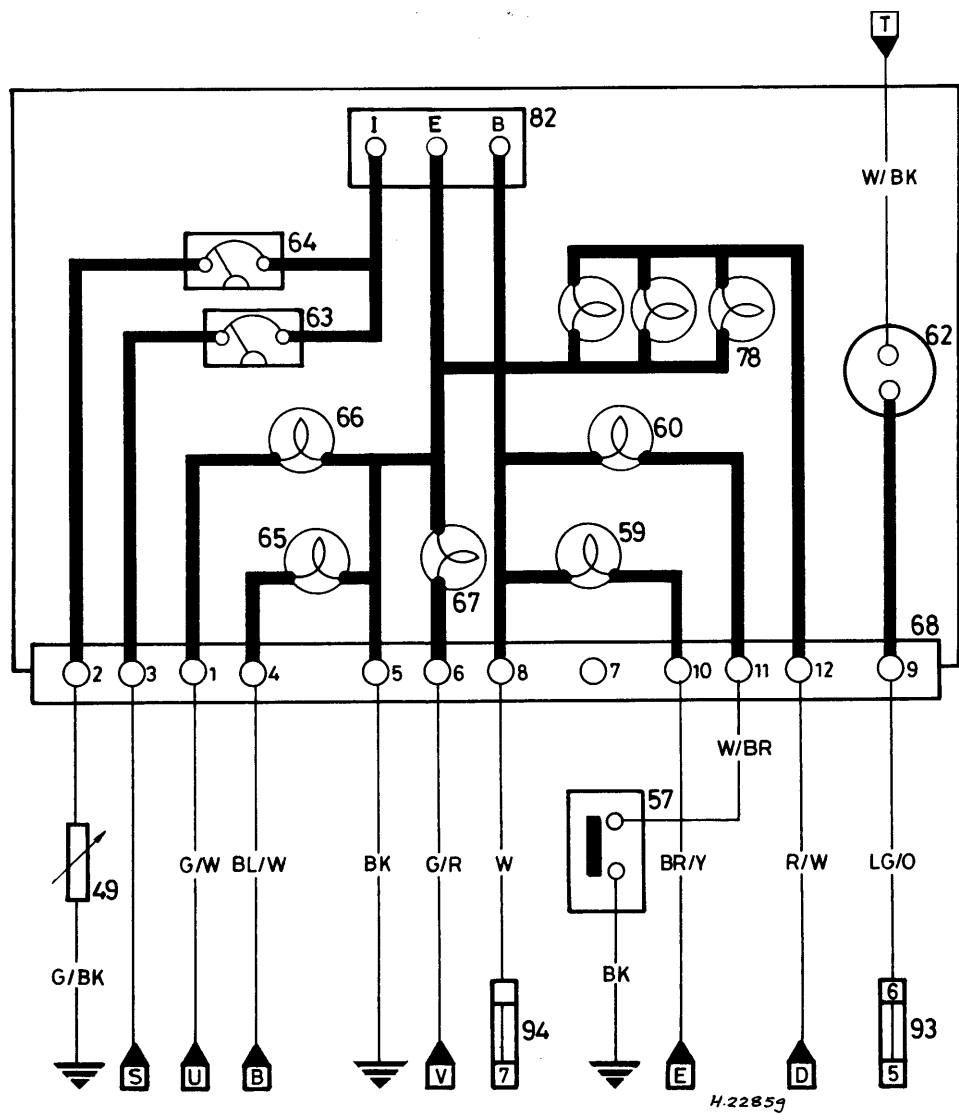

Wiring diagram 22 - Instrument circuit (fuel-injected models)

E to Wiring diagram 20  
 B to Wiring diagram 19  
 D to Wiring diagram 19  
 S to Wiring diagram 21  
 T to Wiring diagram 21  
 U to Wiring diagram 23  
 V to Wiring diagram 23

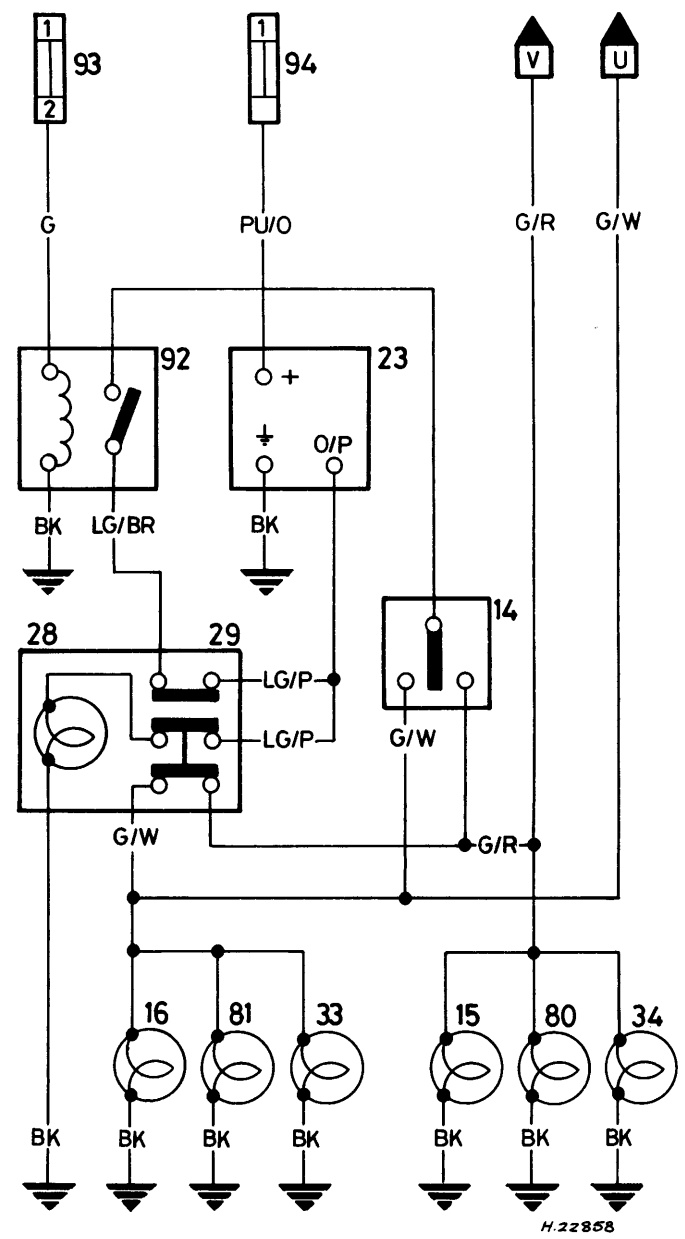

Wiring diagram 23 - Direction indicator and hazard warning light circuit (fuel-injected models)

U to Wiring diagram 22  
 V to Wiring diagram 22

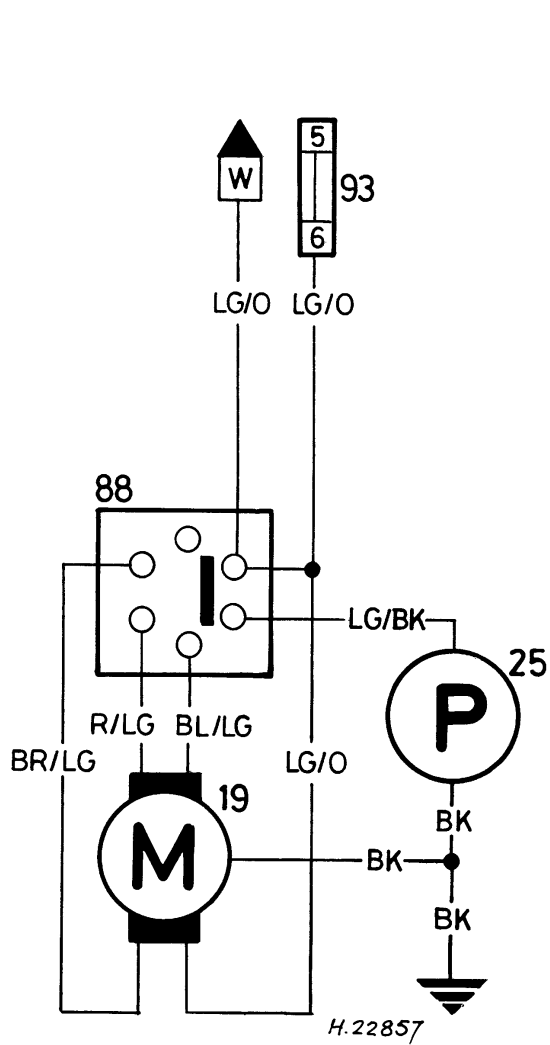

Wiring diagram 24 - Wash/wipe circuit  
(fuel-injected models)

W to Wiring diagram 30

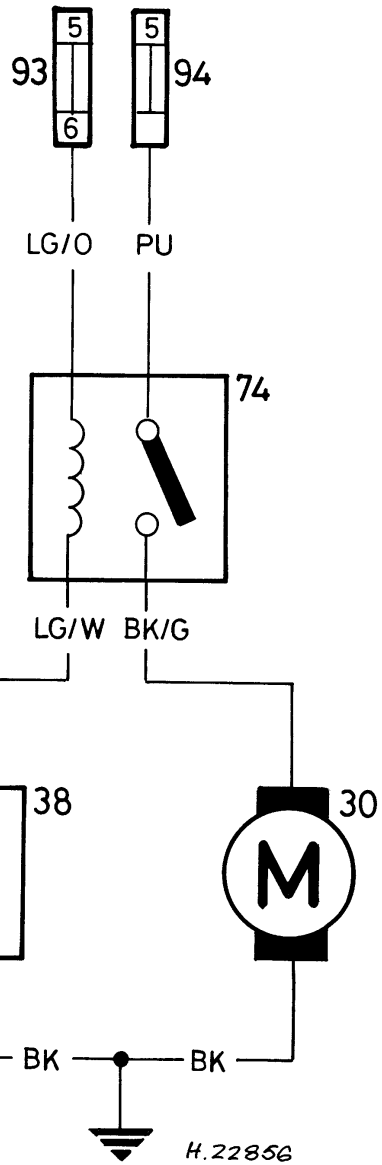

Wiring diagram 25 - Auxiliary cooling fan circuit  
(fuel-injected models)

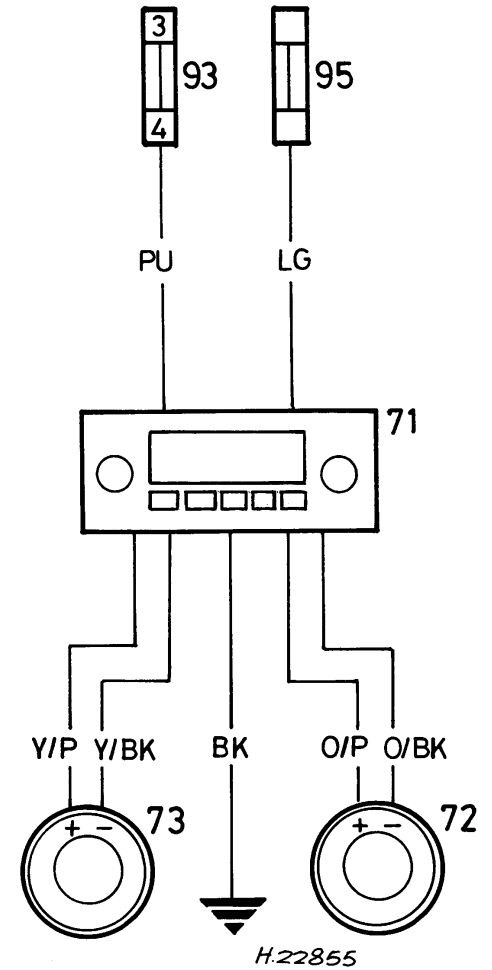

Wiring diagram 26 - Radio/cassette player circuit  
(fuel-injected models)

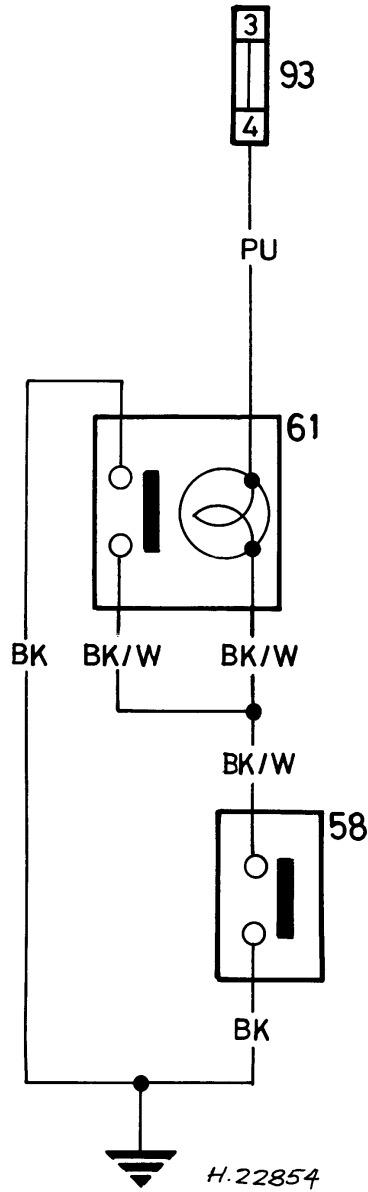

Wiring diagram 27 - Brake test circuit  
(fuel-injected models)

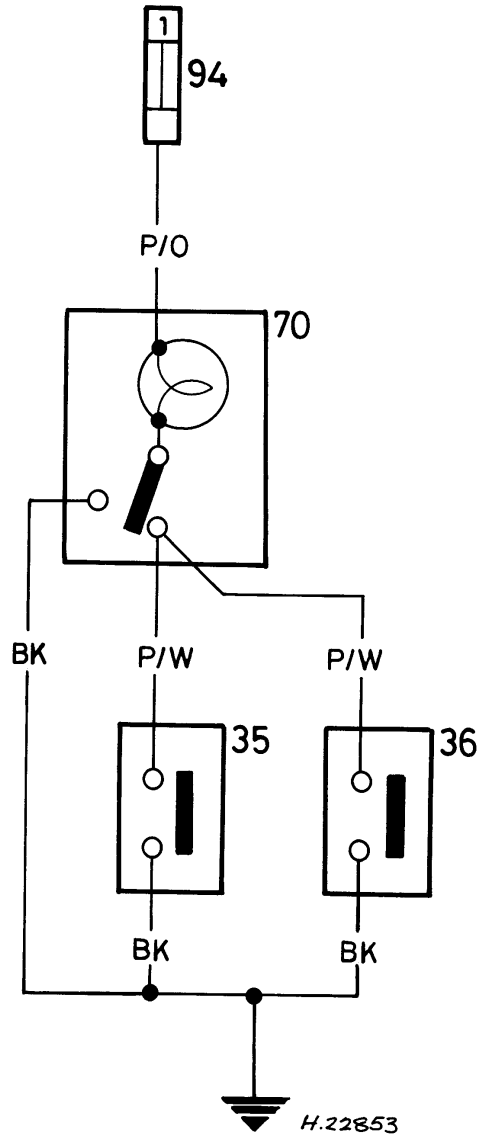

Wiring diagram 28 - Interior light circuit  
(fuel-injected models)

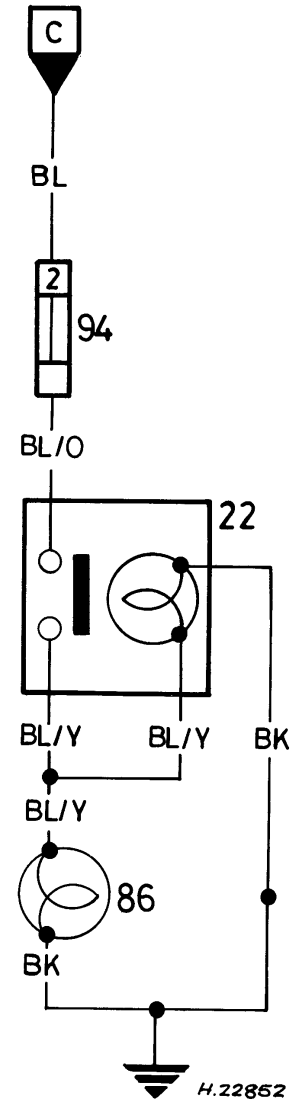

Wiring diagram 29 - Foglight circuit  
(fuel-injected models)

C to Wiring diagram 19

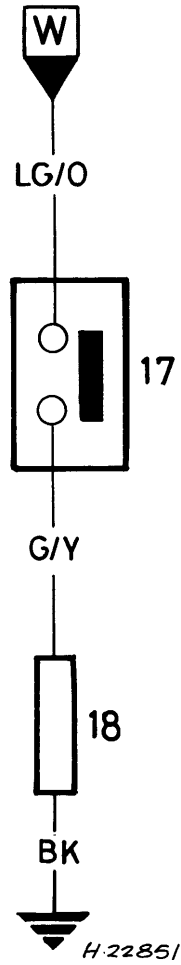

Wiring diagram 30 - Heater circuit  
(fuel-injected models)

W to Wiring diagram 24

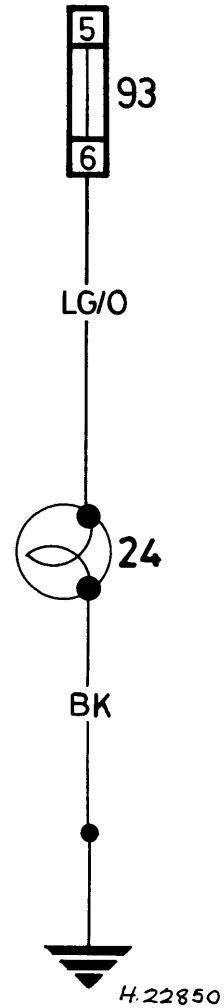

Wiring diagram 31 - Automatic transmission selector  
illumination circuit (fuel-injected models)



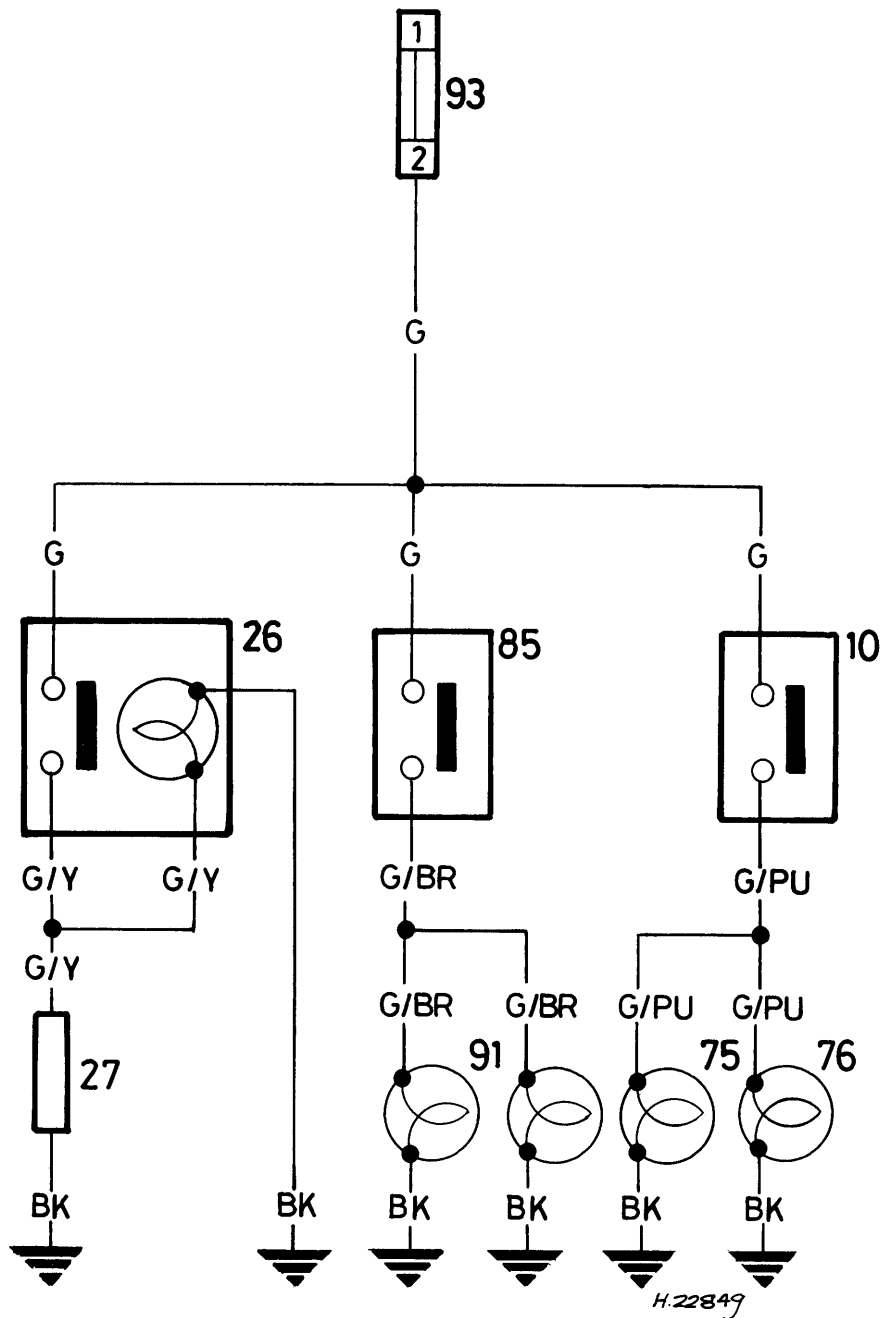

Wiring diagram 32 - Reversing light, stop-light and heated rear window circuit (fuel-injected models)

Dimensions and weights . . . . .	REF•1	Tools and working facilities . . . . .	REF•4
Conversion factors . . . . .	REF•2	MOT test checks . . . . .	REF•6
Buying spare parts . . . . .	REF•3	Fault finding . . . . .	REF•10
Vehicle identification . . . . .	REF•3	General repair procedures . . . . .	REF•17
Jacking and vehicle support . . . . .	REF•3	Glossary of technical terms . . . . .	REF•18
Radio/cassette anti-theft system - precaution .REF•3		Index . . . . .	REF•22

## Dimensions and weights

---

**Note:** All figures are approximate, and may vary according to model. Refer to manufacturer's data for exact figures.

### Dimensions

Overall length:	
Saloon . . . . .	3054 mm
Clubman Saloon . . . . .	3165 mm
Cooper (1990-on) . . . . .	3061 mm
Estate . . . . .	3403 mm
Van . . . . .	3298 mm
Pick-up . . . . .	3314 mm
Overall width:	
All models except Cooper (1990-on) . . . . .	1410 mm
Cooper (1990-on) including mirrors . . . . .	1560 mm
Overall height:	
Saloon:	
Pre-1985 models . . . . .	1346 mm
1985 models-on . . . . .	1353 mm
Cooper (1990-on) . . . . .	1331 mm
Estate, Van and Pick-up . . . . .	1359 mm
Wheelbase:	
Saloon . . . . .	2036 mm
Estate, Van and Pick-up . . . . .	2134 mm

### Weights

Kerb weight:	
Saloon (rubber cone suspension):	
Manual transmission . . . . .	638 kg
Automatic transmission . . . . .	658 kg
Saloon (Hydrolastic suspension):	
Manual transmission . . . . .	679.5 kg
Automatic transmission . . . . .	699.3 kg
Estate . . . . .	686.7 kg
Van . . . . .	621.5 kg
Pick-up . . . . .	622.4 kg
Maximum towing weights:	
Saloon . . . . .	404 kg
Estate, Van and Pick-up . . . . .	303 kg
Maximum towing hitch load . . . . .	45 kg
Maximum roof rack load . . . . .	40 kg

# REF•2 Conversion factors

## Length (distance)

Inches (in)	x 25.4 = Millimetres (mm)	x 0.0394 = Inches (in)
Feet (ft)	x 0.305 = Metres (m)	x 3.281 = Feet (ft)
Miles	x 1.609 = Kilometres (km)	x 0.621 = Miles

## Volume (capacity)

Cubic inches (cu in; in <sup>3</sup> )	x 16.387 = Cubic centimetres (cc; cm <sup>3</sup> )	x 0.061 = Cubic inches (cu in; in <sup>3</sup> )
Imperial pints (Imp pt)	x 0.568 = Litres (l)	x 1.76 = Imperial pints (Imp pt)
Imperial quarts (Imp qt)	x 1.137 = Litres (l)	x 0.88 = Imperial quarts (Imp qt)
Imperial quarts (Imp qt)	x 1.201 = US quarts (US qt)	x 0.833 = Imperial quarts (Imp qt)
US quarts (US qt)	x 0.946 = Litres (l)	x 1.057 = US quarts (US qt)
Imperial gallons (Imp gal)	x 4.546 = Litres (l)	x 0.22 = Imperial gallons (Imp gal)
Imperial gallons (Imp gal)	x 1.201 = US gallons (US gal)	x 0.833 = Imperial gallons (Imp gal)
US gallons (US gal)	x 3.785 = Litres (l)	x 0.264 = US gallons (US gal)

## Mass (weight)

Ounces (oz)	x 28.35 = Grams (g)	x 0.035 = Ounces (oz)
Pounds (lb)	x 0.454 = Kilograms (kg)	x 2.205 = Pounds (lb)

## Force

Ounces-force (ozf; oz)	x 0.278 = Newtons (N)	x 3.6 = Ounces-force (ozf; oz)
Pounds-force (lbf; lb)	x 4.448 = Newtons (N)	x 0.225 = Pounds-force (lbf; lb)
Newtons (N)	x 0.1 = Kilograms-force (kgf; kg)	x 9.81 = Newtons (N)

## Pressure

Pounds-force per square inch (psi; lbf/in <sup>2</sup> ; lb/in <sup>2</sup> )	x 0.070 = Kilograms-force per square centimetre (kgf/cm <sup>2</sup> ; kg/cm <sup>2</sup> )	x 14.223 = Pounds-force per square inch (psi; lbf/in <sup>2</sup> ; lb/in <sup>2</sup> )
Pounds-force per square inch (psi; lbf/in <sup>2</sup> ; lb/in <sup>2</sup> )	x 0.068 = Atmospheres (atm)	x 14.696 = Pounds-force per square inch (psi; lbf/in <sup>2</sup> ; lb/in <sup>2</sup> )
Pounds-force per square inch (psi; lbf/in <sup>2</sup> ; lb/in <sup>2</sup> )	x 0.069 = Bars	x 14.5 = Pounds-force per square inch (psi; lbf/in <sup>2</sup> ; lb/in <sup>2</sup> )
Pounds-force per square inch (psi; lbf/in <sup>2</sup> ; lb/in <sup>2</sup> )	x 6.895 = Kilopascals (kPa)	x 0.145 = Pounds-force per square inch (psi; lbf/in <sup>2</sup> ; lb/in <sup>2</sup> )
Kilopascals (kPa)	x 0.01 = Kilograms-force per square centimetre (kgf/cm <sup>2</sup> ; kg/cm <sup>2</sup> )	x 98.1 = Kilopascals (kPa)
Millibar (mbar)	x 100 = Pascals (Pa)	x 0.01 = Millibar (mbar)
Millibar (mbar)	x 0.0145 = Pounds-force per square inch (psi; lbf/in <sup>2</sup> ; lb/in <sup>2</sup> )	x 68.947 = Millibar (mbar)
Millibar (mbar)	x 0.75 = Millimetres of mercury (mmHg)	x 1.333 = Millibar (mbar)
Millibar (mbar)	x 0.401 = Inches of water (inH <sub>2</sub> O)	x 2.491 = Millibar (mbar)
Millimetres of mercury (mmHg)	x 0.535 = Inches of water (inH <sub>2</sub> O)	x 1.868 = Millimetres of mercury (mmHg)
Inches of water (inH <sub>2</sub> O)	x 0.036 = Pounds-force per square inch (psi; lbf/in <sup>2</sup> ; lb/in <sup>2</sup> )	x 27.68 = Inches of water (inH <sub>2</sub> O)

## Torque (moment of force)

Pounds-force inches (lbf in; lb in)	x 1.152 = Kilograms-force centimetre (kgf cm; kg cm)	x 0.868 = Pounds-force inches (lbf in; lb in)
Pounds-force inches (lbf in; lb in)	x 0.113 = Newton metres (Nm)	x 8.85 = Pounds-force inches (lbf in; lb in)
Pounds-force inches (lbf in; lb in)	x 0.083 = Pounds-force feet (lbf ft; lb ft)	x 12 = Pounds-force inches (lbf in; lb in)
Pounds-force feet (lbf ft; lb ft)	x 0.138 = Kilograms-force metres (kgf m; kg m)	x 7.233 = Pounds-force feet (lbf ft; lb ft)
Pounds-force feet (lbf ft; lb ft)	x 1.356 = Newton metres (Nm)	x 0.738 = Pounds-force feet (lbf ft; lb ft)
Newton metres (Nm)	x 0.102 = Kilograms-force metres (kgf m; kg m)	x 9.804 = Newton metres (Nm)

## Power

Horsepower (hp)	x 745.7 = Watts (W)	x 0.0013 = Horsepower (hp)
-----------------	---------------------	----------------------------

## Velocity (speed)

Miles per hour (miles/hr; mph)	x 1.609 = Kilometres per hour (km/hr; kph)	x 0.621 = Miles per hour (miles/hr; mph)
--------------------------------	--	--

## Fuel consumption\*

Miles per gallon (mpg)	x 0.354 = Kilometres per litre (km/l)	x 2.825 = Miles per gallon (mpg)
------------------------	---------------------------------------	----------------------------------

## Temperature

Degrees Fahrenheit = (°C x 1.8) + 32	Degrees Celsius (Degrees Centigrade; °C) = (°F - 32) x 0.56
--------------------------------------	---

\* It is common practice to convert from miles per gallon (mpg) to litres/100 kilometres (l/100km), where mpg x 1/100 km = 282

## Buying spare parts

Spare parts are available from many sources, including maker's appointed garages, accessory shops, and motor factors. To be sure of obtaining the correct parts, it will sometimes be necessary to quote the vehicle identification number. If possible, it can also be useful to take the old parts along for positive identification. Items such as starter motors and alternators may be available under a service exchange scheme - any parts returned should always be clean.

Our advice regarding spare part sources is as follows.

### Officially-appointed garages

This is the best source of parts which are peculiar to your car, and which are not otherwise generally available (eg badges, interior trim, certain body panels, etc). It is also the only place at which you should buy parts if the vehicle is still under warranty.

### Accessory shops

These are very good places to buy materials and components needed for the maintenance of your car (oil, air and fuel

filters, spark plugs, light bulbs, drivebelts, oils and greases, brake pads, touch-up paint, etc). Components of this nature sold by a reputable shop are of the same standard as those used by the car manufacturer.

Besides components, these shops also sell tools and general accessories, usually have convenient opening hours, charge lower prices, and can often be found not far from home. Some accessory shops have parts counters where the components needed for almost any repair job can be purchased or ordered.

### Motor factors

Good factors will stock all the more important components which wear out comparatively quickly, and can sometimes supply individual components needed for the overhaul of a larger assembly (eg brake seals and hydraulic parts, bearing shells, pistons, valves, alternator brushes). They may also handle work such as cylinder block reboring, crankshaft regrinding and balancing, etc.

### Tyre and exhaust specialists

These outlets may be independent, or

members of a local or national chain. They frequently offer competitive prices when compared with a main dealer or local garage, but it will pay to obtain several quotes before making a decision. When researching prices, also ask what "extras" may be added - for instance, fitting a new valve and balancing the wheel are both commonly charged on top of the price of a new tyre.

### Other sources

Beware of parts or materials obtained from market stalls, car boot sales or similar outlets. Such items are not invariably sub-standard, but there is little chance of compensation if they do prove unsatisfactory. In the case of safety-critical components such as brake pads, there is the risk not only of financial loss but also of an accident causing injury or death.

Second-hand components or assemblies obtained from a car breaker can be a good buy in some circumstances, but this sort of purchase is best made by the experienced DIY mechanic.

## Vehicle identification

When ordering spare parts it is essential to provide the full details of your car. It will be necessary to quote the commission and car numbers on early models, or the vehicle identification (VIN) number on later models. When ordering parts for the engine, transmission unit or body it will also be necessary to supply these numbers.

The *commission number* (early models) is stamped on a plate fixed to the bonnet locking platform.

The *car number* (early models) is located on a plate mounted adjacent to the commission number.

The *vehicle identification number* (later models) is stamped on a plate attached to the right-hand inner wing valance.

The *engine number* is stamped on the cylinder block or on a metal plate fixed to the right-hand side of the cylinder block.

The *transmission casing assembly number* is stamped on a facing provided on the casting just below the starter motor.

The *body number* is stamped on a metal plate fixed to the bonnet locking platform.

## Jacking and vehicle support

The jack supplied with the vehicle tool kit should only be used for changing the roadwheels - see "*Wheel changing*" at the front of this manual. When carrying out any other kind of work, raise the vehicle using a hydraulic (or "trolley") jack, and always supplement the jack with axle stands.

The reinforced side members of the front

and rear subframes should be used as jacking points for raising one side of the car at the front or rear. A beam may be placed transversely under the front and rear subframes, with the jack head positioned centrally under it, if it is wished to raise the complete front or rear of the car. Take care not to damage the exhaust system or any

pipes or hoses if this method is being used. The side-members of the subframes should also be used as axle stand support points.

**Never** work under, around, or near a raised vehicle, unless it is adequately supported in at least two places.

## Radio/cassette unit anti-theft system - precaution

The radio/cassette unit fitted as standard or optional equipment may be equipped with a built-in security code, to deter thieves. If the power source to the unit is cut, the anti-theft system will activate. Even if the power source is immediately reconnected, the radio/cassette unit will not function until the correct security code has been entered. Therefore, if you do not know the correct security code for the radio/cassette unit **do not** disconnect either of

the battery terminals, or remove the radio/cassette unit from the vehicle.

To enter the correct security code, follow the instructions provided with the radio/cassette player or vehicle handbook.

If an incorrect code is entered, the unit will become locked, and cannot be operated.

If this happens, or if the security code is lost or forgotten, seek the advice of your Rover dealer.

On later models equipped with a factory fitted anti-theft alarm system, the radio signal code is electronically changed each time the alarm handset is used. If the handset battery is replaced or the car battery disconnected, the signal sequence will be lost. To restore synchronisation, hold the handset close to the car and press the handset LOCK button four times in quick succession.



## Introduction

A selection of good tools is a fundamental requirement for anyone contemplating the maintenance and repair of a motor vehicle. For the owner who does not possess any, their purchase will prove a considerable expense, offsetting some of the savings made by doing-it-yourself. However, provided that the tools purchased meet the relevant national safety standards and are of good quality, they will last for many years and prove an extremely worthwhile investment.

To help the average owner to decide which tools are needed to carry out the various tasks detailed in this manual, we have compiled three lists of tools under the following headings: *Maintenance and minor repair*, *Repair and overhaul*, and *Special*. Newcomers to practical mechanics should start off with the *Maintenance and minor repair* tool kit, and confine themselves to the simpler jobs around the vehicle. Then, as confidence and experience grow, more difficult tasks can be undertaken, with extra tools being purchased as, and when, they are needed. In this way, a *Maintenance and minor repair* tool kit can be built up into a *Repair and overhaul* tool kit over a considerable period of time, without any major cash outlays. The experienced do-it-yourselfer will have a tool kit good enough for most repair and overhaul procedures, and will add tools from the *Special* category when it is felt that the expense is justified by the amount of use to which these tools will be put.

## Maintenance and minor repair tool kit

The tools given in this list should be considered as a minimum requirement if routine maintenance, servicing and minor repair operations are to be undertaken. We recommend the purchase of combination spanners (ring one end, open-ended the other); although more expensive than open-ended ones, they do give the advantages of both types of spanner.

- Combination spanners:*  
Imperial - 5/16, 3/8, 7/16, 1/2, 9/16, 5/8, 11/16, 3/4 inch AF  
Metric - 8, 9, 10, 11, 12, 13, 14, 15, 17 & 19 mm
- Adjustable spanner - 35 mm jaw (approx.)
- Spark plug spanner (with rubber insert)
- Spark plug gap adjustment tool
- Set of feeler gauges
- Brake adjuster spanner
- Brake bleed nipple spanner
- Screwdrivers:  
Flat blade - 100 mm long x 6 mm dia  
Cross blade - 100 mm long x 6 mm dia
- Combination pliers
- Hacksaw (junior)
- Tyre pump
- Tyre pressure gauge
- Grease gun
- Oil can
- Oil filter removal tool
- Fine emery cloth
- Wire brush (small)
- Funnel (medium size)

## Repair and overhaul tool kit

These tools are virtually essential for anyone undertaking any major repairs to a motor vehicle, and are additional to those given in the *Maintenance and minor repair* list. Included in this list is a comprehensive set of sockets. Although these are expensive, they will be found invaluable as they are so versatile - particularly if various drives are included in the set. We recommend the half-inch square-drive type, as this can be used with most proprietary torque wrenches. If you cannot afford a socket set, even bought piecemeal, then inexpensive tubular box spanners are a useful alternative.

The tools in this list will occasionally need to be supplemented by tools from the *Special* list:

- Sockets (or box spanners) to cover range in previous list (including Torx sockets)
- Reversible ratchet drive (for use with sockets)
- Extension piece, 250 mm (for use with sockets)
- Universal joint (for use with sockets)
- Torque wrench (for use with sockets)
- Self-locking grips
- Ball pein hammer
- Soft-faced mallet (plastic/aluminium or rubber)
- Screwdrivers:  
Flat blade - long & sturdy, short (chubby), and narrow (electrician's) types  
Cross blade - Long & sturdy, and short (chubby) types
- Pliers:  
Long-nosed  
Side cutters (electrician's)  
Circlip (internal and external)
- Cold chisel - 25 mm
- Scriber
- Scraper
- Centre-punch
- Pin punch
- Hacksaw
- Brake hose clamp
- Brake/clutch bleeding kit
- Selection of twist drills
- Steel rule/straight-edge
- Allen keys (inc. splined/Torx type)
- Selection of files
- Wire brush
- Axle stands
- Jack (strong trolley or hydraulic type)
- Light with extension lead



Sockets and reversible drive ratchet



Valve spring compressor



Vernier caliper



Piston ring compressor



Two/three legged puller

## Special tools

The tools in this list are those which are not used regularly, are expensive to buy, or which need to be used in accordance with their manufacturers' instructions. Unless relatively difficult mechanical jobs are undertaken frequently, it will not be economic to buy many of these tools. Where this is the case, you could consider clubbing together with friends (or joining a motorists' club) to make a joint purchase, or borrowing the tools against a deposit from a local garage or tool hire specialist. It is worth noting that many of the larger DIY superstores now carry a large range of special tools for hire at modest rates.

The following list contains only those tools and instruments freely available to the public, and not those special tools produced by the vehicle manufacturer specifically for its dealer network. You will find occasional references to these manufacturers' special tools in the text of this manual. Generally, an alternative method of doing the job without the vehicle manufacturers' special tool is given. However, sometimes there is no alternative to using them. Where this is the case and the relevant tool cannot be bought or borrowed, you will have to entrust the work to a franchised garage.

- Valve spring compressor
- Valve grinding tool
- Piston ring compressor
- Piston ring removal/installation tool
- Balljoint separator
- Coil spring compressors (where applicable)
- Two/three-legged hub and bearing puller
- Impact screwdriver
- Micrometer and/or vernier calipers
- Dial gauge
- Stroboscopic timing light
- Dwell angle meter/tachometer
- Universal electrical multi-meter
- Cylinder compression gauge
- Hand-operated vacuum pump and gauge
- Bush and bearing removal/installation set
- Stud extractors
- Tap and die set
- Lifting tackle
- Trolley jack



Stroboscopic timing light

## Buying tools

For practically all tools, a tool factor is the best source, since he will have a very comprehensive range compared with the average garage or accessory shop. Having said that, accessory shops often offer excellent quality tools at discount prices, so it pays to shop around.

Remember, you don't have to buy the most expensive items on the shelf, but it is always advisable to steer clear of the very cheap tools. There are plenty of good tools around at reasonable prices, but always aim to purchase items which meet the relevant national safety standards. If in doubt, ask the proprietor or manager of the shop for advice before making a purchase.

## Care and maintenance of tools

Having purchased a reasonable tool kit, it is necessary to keep the tools in a clean and serviceable condition. After use, always wipe off any dirt, grease and metal particles using a clean, dry cloth, before putting the tools away. Never leave them lying around after they have been used. A simple tool rack on the garage or workshop wall for items such as screwdrivers and pliers is a good idea. Store all normal spanners and sockets in a metal box. Any measuring instruments, gauges, meters, etc, must be carefully stored where they cannot be damaged or become rusty.

Take a little care when tools are used. Hammer heads inevitably become marked, and screwdrivers lose the keen edge on their blades



Micrometer set

from time to time. A little timely attention with emery cloth or a file will soon restore items like this to a good serviceable finish.

## Working facilities

Not to be forgotten when discussing tools is the workshop itself. If anything more than routine maintenance is to be carried out, some form of suitable working area becomes essential.

It is appreciated that many an owner-mechanic is forced by circumstances to remove an engine or similar item without the benefit of a garage or workshop. Having done this, any repairs should always be done under the cover of a roof.

Wherever possible, any dismantling should be done on a clean, flat workbench or table at a suitable working height.

Any workbench needs a vice; one with a jaw opening of 100 mm is suitable for most jobs. As mentioned previously, some clean dry storage space is also required for tools, as well as for any lubricants, cleaning fluids, touch-up paints and so on, which become necessary.

Another item which may be required, and which has a much more general usage, is an electric drill with a chuck capacity of at least 8 mm. This, together with a good range of twist drills, is virtually essential for fitting accessories.

Last, but not least, always keep a supply of old newspapers and clean, lint-free rags available, and try to keep any working area as clean as possible.



Dial test indicator ("dial gauge")



Compression tester



Stud extractor set

# REF•6 MOT test checks

This is a guide to getting your vehicle through the MOT test. Obviously it will not be possible to examine the vehicle to the same standard as the professional MOT tester. However, working through the following checks will enable you to identify any problem areas before submitting the vehicle for the test.

Where a testable component is in borderline condition, the tester has discretion in deciding whether to pass or fail it. The basis of such discretion is whether the tester would be happy for a close relative or friend to use the vehicle with the component in that condition. If the vehicle presented is clean and evidently well cared for, the tester may be more inclined to pass a borderline component than if the vehicle is scruffy and apparently neglected.

It has only been possible to summarise the test requirements here, based on the regulations in force at the time of printing. Test standards are becoming increasingly stringent, although there are some exemptions for older vehicles. For full details obtain a copy of the Haynes publication *Pass the MOT!* (available from stockists of Haynes manuals).

An assistant will be needed to help carry out some of these checks.



The checks have been sub-divided into four categories, as follows:

**1** Checks carried out **FROM THE DRIVER'S SEAT**

**2** Checks carried out **WITH THE VEHICLE ON THE GROUND**

**3** Checks carried out **WITH THE VEHICLE RAISED AND THE WHEELS FREE TO TURN**

**4** Checks carried out on **YOUR VEHICLE'S EXHAUST EMISSION SYSTEM**

**1** Checks carried out **FROM THE DRIVER'S SEAT**

## Handbrake

Test the operation of the handbrake. Excessive travel (too many clicks) indicates incorrect brake or cable adjustment.

Check that the handbrake cannot be released by tapping the lever sideways. Check the security of the lever mountings.



## Footbrake

Depress the brake pedal and check that it does not creep down to the floor, indicating a master cylinder fault. Release the pedal, wait a few seconds, then depress it again. If the pedal travels nearly to the floor before firm resistance is felt, brake adjustment or repair is necessary. If the pedal feels spongy, there is air in the hydraulic system which must be removed by bleeding.



Check that the brake pedal is secure and in good condition. Check also for signs of fluid leaks on the pedal, floor or carpets, which would indicate failed seals in the brake master cylinder.

Check the servo unit (when applicable) by operating the brake pedal several times, then keeping the pedal depressed and starting the engine. As the engine starts, the pedal will move down slightly. If not, the vacuum hose or the servo itself may be faulty.

## Steering wheel and column

Examine the steering wheel for fractures or looseness of the hub, spokes or rim.

Move the steering wheel from side to side and then up and down. Check that the steering wheel is not loose on the column, indicating wear or a loose retaining nut. Continue moving the steering wheel as before, but also turn it slightly from left to right.

Check that the steering wheel is not loose on the column, and that there is no abnormal



movement of the steering wheel, indicating wear in the column support bearings or couplings.

## Windscreen and mirrors

The windscreen must be free of cracks or other significant damage within the driver's field of view. (Small stone chips are acceptable.) Rear view mirrors must be secure, intact, and capable of being adjusted.

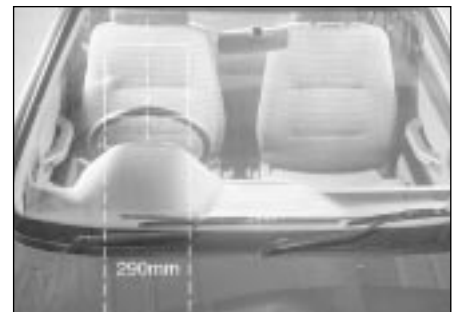





## Seat belts and seats

**Note:** The following checks are applicable to all seat belts, front and rear.

- Examine the webbing of all the belts (including rear belts if fitted) for cuts, serious fraying or deterioration. Fasten and unfasten each belt to check the buckles. If applicable, check the retracting mechanism. Check the security of all seat belt mountings accessible from inside the vehicle.
- The front seats themselves must be securely attached and the backrests must lock in the upright position.

## Doors

- Both front doors must be able to be opened and closed from outside and inside, and must latch securely when closed.

## 2 Checks carried out WITH THE VEHICLE ON THE GROUND

### Vehicle identification

- Number plates must be in good condition, secure and legible, with letters and numbers correctly spaced – spacing at (A) should be twice that at (B).



- The VIN plate and/or homologation plate must be legible.



### Electrical equipment

- Switch on the ignition and check the operation of the horn.
- Check the windscreen washers and wipers, examining the wiper blades; renew damaged or perished blades. Also check the operation of the stop-lights.



- Check the operation of the sidelights and number plate lights. The lenses and reflectors must be secure, clean and undamaged.
- Check the operation and alignment of the headlights. The headlight reflectors must not be tarnished and the lenses must be undamaged.
- Switch on the ignition and check the operation of the direction indicators (including the instrument panel tell-tale) and the hazard warning lights. Operation of the sidelights and stop-lights must not affect the indicators - if it does, the cause is usually a bad earth at the rear light cluster.
- Check the operation of the rear foglight(s), including the warning light on the instrument panel or in the switch.

### Footbrake

- Examine the master cylinder, brake pipes and servo unit for leaks, loose mountings, corrosion or other damage.



- The fluid reservoir must be secure and the fluid level must be between the upper (A) and lower (B) markings.

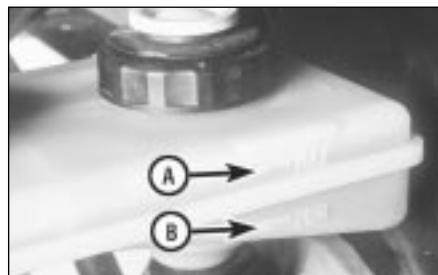

- Inspect both front brake flexible hoses for cracks or deterioration of the rubber. Turn the steering from lock to lock, and ensure that the hoses do not contact the wheel, tyre, or any part of the steering or suspension mechanism. With the brake pedal firmly depressed, check the hoses for bulges or leaks under pressure.



### Steering and suspension

- Have your assistant turn the steering wheel from side to side slightly, up to the point where the steering gear just begins to transmit this movement to the roadwheels. Check for excessive free play between the steering wheel and the steering gear, indicating wear or insecurity of the steering column joints, the column-to-steering gear coupling, or the steering gear itself.
- Have your assistant turn the steering wheel more vigorously in each direction, so that the roadwheels just begin to turn. As this is done, examine all the steering joints, linkages, fittings and attachments. Renew any component that shows signs of wear or damage. On vehicles with power steering, check the security and condition of the steering pump, drivebelt and hoses.
- Check that the vehicle is standing level, and at approximately the correct ride height.

### Shock absorbers

- Depress each corner of the vehicle in turn, then release it. The vehicle should rise and then settle in its normal position. If the vehicle continues to rise and fall, the shock absorber is defective. A shock absorber which has seized will also cause the vehicle to fail.





## Exhaust system

□ Start the engine. With your assistant holding a rag over the tailpipe, check the entire system for leaks. Repair or renew leaking sections.

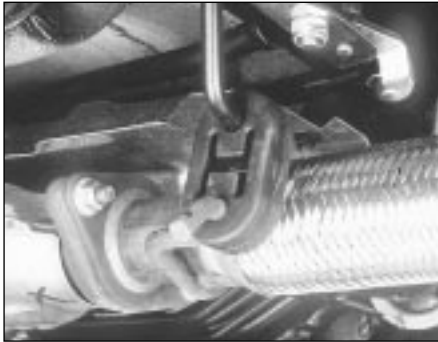

## 3 Checks carried out WITH THE VEHICLE RAISED AND THE WHEELS FREE TO TURN

**Jack up the front and rear of the vehicle, and securely support it on axle stands. Position the stands clear of the suspension assemblies. Ensure that the wheels are clear of the ground and that the steering can be turned from lock to lock.**

## Steering mechanism

□ Have your assistant turn the steering from lock to lock. Check that the steering turns smoothly, and that no part of the steering mechanism, including a wheel or tyre, fouls any brake hose or pipe or any part of the body structure.

□ Examine the steering rack rubber gaiters for damage or insecurity of the retaining clips. If power steering is fitted, check for signs of damage or leakage of the fluid hoses, pipes or connections. Also check for excessive stiffness or binding of the steering, a missing split pin or locking device, or severe corrosion of the body structure within 30 cm of any steering component attachment point.



## Front and rear suspension and wheel bearings

□ Starting at the front right-hand side, grasp the roadwheel at the 3 o'clock and 9 o'clock positions and shake it vigorously. Check for free play or insecurity at the wheel bearings, suspension balljoints, or suspension mountings, pivots and attachments.

□ Now grasp the wheel at the 12 o'clock and 6 o'clock positions and repeat the previous inspection. Spin the wheel, and check for roughness or tightness of the front wheel bearing.



□ If excess free play is suspected at a component pivot point, this can be confirmed by using a large screwdriver or similar tool and levering between the mounting and the component attachment. This will confirm whether the wear is in the pivot bush, its retaining bolt, or in the mounting itself (the bolt holes can often become elongated).



□ Carry out all the above checks at the other front wheel, and then at both rear wheels.

## Springs and shock absorbers

□ Examine the suspension struts (when applicable) for serious fluid leakage, corrosion, or damage to the casing. Also check the security of the mounting points.

□ If coil springs are fitted, check that the spring ends locate in their seats, and that the spring is not corroded, cracked or broken.

□ If leaf springs are fitted, check that all leaves are intact, that the axle is securely attached to each spring, and that there is no deterioration of the spring eye mountings, bushes, and shackles.

□ The same general checks apply to vehicles fitted with other suspension types, such as torsion bars, hydraulic displacer units, etc. Ensure that all mountings and attachments are secure, that there are no signs of excessive wear, corrosion or damage, and (on hydraulic types) that there are no fluid leaks or damaged pipes.

□ Inspect the shock absorbers for signs of serious fluid leakage. Check for wear of the mounting bushes or attachments, or damage to the body of the unit.

## Driveshafts (fwd vehicles only)

□ Rotate each front wheel in turn and inspect the constant velocity joint gaiters for splits or damage. Also check that each driveshaft is straight and undamaged.



## Braking system

□ If possible without dismantling, check brake pad wear and disc condition. Ensure that the friction lining material has not worn excessively, (A) and that the discs are not fractured, pitted, scored or badly worn (B).

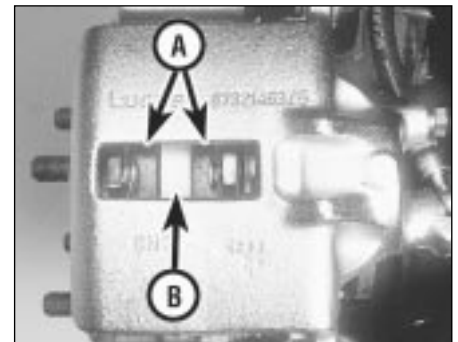

□ Examine all the rigid brake pipes underneath the vehicle, and the flexible hose(s) at the rear. Look for corrosion, chafing or insecurity of the pipes, and for signs of bulging under pressure, chafing, splits or deterioration of the flexible hoses.

□ Look for signs of fluid leaks at the brake calipers or on the brake backplates. Repair or renew leaking components.

□ Slowly spin each wheel, while your assistant depresses and releases the footbrake. Ensure that each brake is operating and does not bind when the pedal is released.

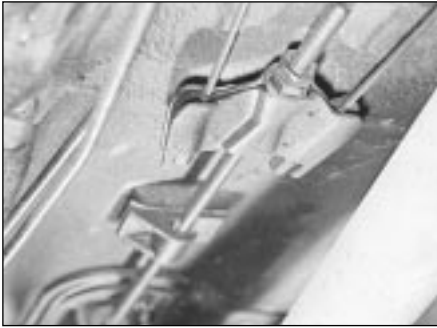

- Examine the handbrake mechanism, checking for frayed or broken cables, excessive corrosion, or wear or insecurity of the linkage. Check that the mechanism works on each relevant wheel, and releases fully, without binding.
- It is not possible to test brake efficiency without special equipment, but a road test can be carried out later to check that the vehicle pulls up in a straight line.

### Fuel and exhaust systems

- Inspect the fuel tank (including the filler cap), fuel pipes, hoses and unions. All components must be secure and free from leaks.
- Examine the exhaust system over its entire length, checking for any damaged, broken or missing mountings, security of the retaining clamps and rust or corrosion.

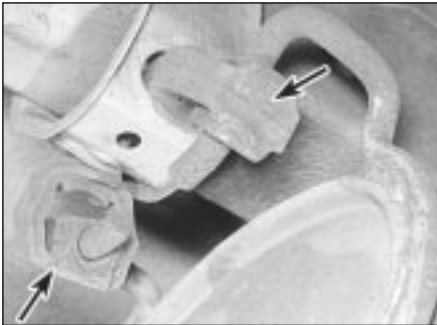

### Wheels and tyres

- Examine the sidewalls and tread area of each tyre in turn. Check for cuts, tears, lumps, bulges, separation of the tread, and exposure of the ply or cord due to wear or damage. Check that the tyre bead is correctly seated on the wheel rim, that the valve is sound and



- properly seated, and that the wheel is not distorted or damaged.
- Check that the tyres are of the correct size for the vehicle, that they are of the same size and type on each axle, and that the pressures are correct.
- Check the tyre tread depth. The legal minimum at the time of writing is 1.6 mm over at least three-quarters of the tread width. Abnormal tread wear may indicate incorrect front wheel alignment.

### Body corrosion

- Check the condition of the entire vehicle structure for signs of corrosion in load-bearing areas. (These include chassis box sections, side sills, cross-members, pillars, and all suspension, steering, braking system and seat belt mountings and anchorages.) Any corrosion which has seriously reduced the thickness of a load-bearing area is likely to cause the vehicle to fail. In this case professional repairs are likely to be needed.
- Damage or corrosion which causes sharp or otherwise dangerous edges to be exposed will also cause the vehicle to fail.

## 4 Checks carried out on YOUR VEHICLE'S EXHAUST EMISSION SYSTEM

### Petrol models

- Have the engine at normal operating temperature, and make sure that it is in good tune (ignition system in good order, air filter element clean, etc).
- Before any measurements are carried out, raise the engine speed to around 2500 rpm, and hold it at this speed for 20 seconds. Allow

the engine speed to return to idle, and watch for smoke emissions from the exhaust tailpipe. If the idle speed is obviously much too high, or if dense blue or clearly-visible black smoke comes from the tailpipe for more than 5 seconds, the vehicle will fail. As a rule of thumb, blue smoke signifies oil being burnt (engine wear) while black smoke signifies unburnt fuel (dirty air cleaner element, or other carburettor or fuel system fault).

- An exhaust gas analyser capable of measuring carbon monoxide (CO) and hydrocarbons (HC) is now needed. If such an instrument cannot be hired or borrowed, a local garage may agree to perform the check for a small fee.

### CO emissions (mixture)

- At the time of writing, the maximum CO level at idle is 3.5% for vehicles first used after August 1986 and 4.5% for older vehicles. From January 1996 a much tighter limit (around 0.5%) applies to catalyst-equipped vehicles first used from August 1992. If the CO level cannot be reduced far enough to pass the test (and the fuel and ignition systems are otherwise in good condition) then the carburettor is badly worn, or there is some problem in the fuel injection system or catalytic converter (as applicable).

### HC emissions

- With the CO emissions within limits, HC emissions must be no more than 1200 ppm (parts per million). If the vehicle fails this test at idle, it can be re-tested at around 2000 rpm; if the HC level is then 1200 ppm or less, this counts as a pass.
- Excessive HC emissions can be caused by oil being burnt, but they are more likely to be due to unburnt fuel.

### Diesel models

- The only emission test applicable to Diesel engines is the measuring of exhaust smoke density. The test involves accelerating the engine several times to its maximum unloaded speed.

**Note:** It is of the utmost importance that the engine timing belt is in good condition before the test is carried out.

- Excessive smoke can be caused by a dirty air cleaner element. Otherwise, professional advice may be needed to find the cause.

**Engine .....1**

- Engine fails to rotate when attempting to start
- Engine rotates, but will not start
- Engine difficult to start when cold
- Engine difficult to start when hot
- Starter motor noisy or excessively-rough in engagement
- Engine starts, but stops immediately
- Engine idles erratically
- Engine misfires at idle speed
- Engine misfires throughout the driving speed range
- Engine hesitates on acceleration
- Engine stalls
- Engine lacks power
- Engine backfires
- Oil pressure warning light illuminated with engine running
- Engine runs-on after switching off
- Engine noises

**Cooling system .....2**

- Overheating
- Overcooling
- External coolant leakage
- Internal coolant leakage
- Corrosion

**Fuel and exhaust systems .....3**

- Excessive fuel consumption
- Fuel leakage and/or fuel odour
- Excessive noise or fumes from exhaust system

**Clutch .....4**

- Pedal travels to floor (no pressure or very little resistance)
- Clutch fails to disengage (unable to select gears)
- Clutch slips (engine speed increases, with no increase in vehicle speed)
- Judder as clutch is engaged
- Noise when depressing or releasing clutch pedal

**Manual transmission .....5**

- Noisy in neutral with engine running
- Noisy in one particular gear
- Difficulty engaging gears
- Jumps out of gear
- Vibration
- Lubricant leaks

**Automatic transmission .....6**

- Fluid leakage
- General gear selection problems
- Transmission will not downshift (kickdown) with accelerator fully depressed
- Engine will not start in any gear, or starts in gears other than Neutral
- Transmission slips, shifts roughly, is noisy, or has no drive in forward or reverse gears

**Driveshafts .....7**

- Clicking or knocking noise on turns (at slow speed on full-lock)
- Vibration when accelerating or decelerating

**Braking system .....8**

- Vehicle pulls to one side under braking
- Noise (grinding or high-pitched squeal) when brakes applied
- Excessive brake pedal travel
- Brake pedal feels spongy when depressed
- Excessive brake pedal effort required to stop vehicle
- Judder felt through brake pedal or steering wheel when braking
- Brakes binding
- Rear wheels locking under normal braking

**Suspension and steering systems .....9**

- Vehicle pulls to one side
- Wheel wobble and vibration
- Excessive pitching and/or rolling around corners, or during braking
- Wandering or general instability
- Excessively-stiff steering
- Excessive play in steering
- Tyre wear excessive

**Electrical system .....10**

- Battery will not hold a charge for more than a few days
- Ignition/no-charge warning light remains illuminated with engine running
- Ignition/no-charge warning light fails to come on
- Lights inoperative
- Instrument readings inaccurate or erratic
- Horn inoperative, or unsatisfactory in operation
- Windscreen wipers inoperative, or unsatisfactory in operation
- Windscreen washers inoperative, or unsatisfactory in operation

## Introduction

The vehicle owner who does his or her own maintenance according to the recommended service schedules should not have to use this section of the manual very often. Modern component reliability is such that, provided those items subject to wear or deterioration are inspected or renewed at the specified intervals, sudden failure is comparatively rare. Faults do not usually just happen as a result of sudden failure, but develop over a period of time. Major mechanical failures in particular are usually preceded by characteristic symptoms over hundreds or even thousands of miles. Those components which do occasionally fail without warning are often small and easily carried in the vehicle.

With any fault-finding, the first step is to

decide where to begin investigations. Sometimes this is obvious, but on other occasions, a little detective work will be necessary. The owner who makes half a dozen haphazard adjustments or replacements may be successful in curing a fault (or its symptoms), but will be none the wiser if the fault recurs, and ultimately may have spent more time and money than was necessary. A calm and logical approach will be found to be more satisfactory in the long run. Always take into account any warning signs or abnormalities that may have been noticed in the period preceding the fault - power loss, high or low gauge readings, unusual smells, etc - and remember that failure of components such as fuses or spark

plugs may only be pointers to some underlying fault.

The pages which follow provide an easy-reference guide to the more common problems which may occur during the operation of the vehicle. These problems and their possible causes are grouped under headings denoting various components or systems, such as Engine, Cooling system, etc. The Chapter and/or Section which deals with the problem is also shown in brackets. Whatever the fault, certain basic principles apply. These are as follows:

*Verify the fault.* This is simply a matter of being sure that you know what the symptoms are before starting work. This is particularly important if you are investigating a fault for

someone else, who may not have described it very accurately.

*Don't overlook the obvious.* For example, if the vehicle won't start, is there petrol in the tank? (Don't take anyone else's word on this particular point, and don't trust the fuel gauge either!) If an electrical fault is indicated, look for loose or broken wires before digging out the test gear.

*Cure the disease, not the symptom.*

Substituting a flat battery with a fully-charged one will get you off the hard shoulder, but if the underlying cause is not attended to, the new battery will go the same way. Similarly, changing oil-fouled spark plugs (petrol models) for a new set will get you moving again, but remember that the reason for the fouling (if it wasn't simply an incorrect grade of plug) will have to be established and corrected.

*Don't take anything for granted.* Particularly, don't forget that a "new" component may itself be defective (especially if it's been rattling around in the boot for months), and don't leave components out of a fault diagnosis sequence just because they are new or recently-fitted. When you do finally diagnose a difficult fault, you'll probably realise that all the evidence was there from the start.

## 1 Engine

### Engine fails to rotate when attempting to start

- Battery terminal connections loose or corroded ("*Weekly checks*").
- Battery discharged or faulty (Chapter 5A).
- Broken, loose or disconnected wiring in the starting circuit (Chapter 5A).
- Defective starter solenoid or switch (Chapter 5A).
- Defective starter motor (Chapter 5A).
- Starter pinion or flywheel ring gear teeth loose or broken (Chapters 2A, 2B, 2C and 5A).
- Engine earth strap broken or disconnected (Chapter 5A).
- Automatic transmission selector not in N, or inhibitor switch faulty (Chapter 7B).

### Engine rotates, but will not start

- Fuel tank empty.
- Battery discharged (engine rotates slowly) (Chapter 5A).
- Battery terminal connections loose or corroded ("*Weekly checks*").
- Ignition components damp or damaged (Chapters 1 and 5B).
- Worn or incorrectly adjusted contact breaker points (Chapter 5B).
- Broken, loose or disconnected wiring in the ignition circuit (Chapters 1 and 5B).
- Worn, faulty or incorrectly-gapped spark plugs (Chapter 1).
- Choke mechanism incorrectly adjusted, worn or sticking - carburettor models (Chapter 4A).
- Fuel injection system fault - fuel injected models (Chapter 4B or 4C).
- Major mechanical failure (eg camshaft drive) (Chapter 2A or 2B).

### Engine difficult to start when cold

- Battery discharged (Chapter 5A).
- Battery terminal connections loose or corroded (Chapter 1).
- Worn, faulty or incorrectly-gapped spark plugs (Chapter 1).
- Worn or incorrectly adjusted contact breaker points (Chapter 5B).
- Choke mechanism incorrectly adjusted, worn or sticking - carburettor models (Chapter 4A).
- Fuel injection system fault - fuel injected models (Chapter 4B or 4C).
- Other ignition system fault (Chapters 1 and 5B).
- Low cylinder compressions (Chapter 2A or 2B).

### Engine difficult to start when hot

- Air filter element dirty or clogged (Chapter 1).
- Choke mechanism incorrectly adjusted, worn or sticking - carburettor models (Chapter 4A).
- Fuel injection system fault - fuel injected models (Chapter 4B).
- Worn or incorrectly adjusted contact breaker points (Chapter 5B).
- Uneven or low cylinder compressions (Chapter 2A).

### Starter motor noisy or excessively-rough in engagement

- Starter pinion or flywheel ring gear teeth loose or broken (Chapters 2A, 2B and 5A).
- Starter motor mounting bolts loose or missing (Chapter 5A).
- Starter motor internal components worn or damaged (Chapter 5A).

### Engine starts, but stops immediately

- Loose or faulty electrical connections in the ignition circuit (Chapters 1 and 5B).
- Vacuum leak at the carburettor/throttle body or inlet manifold (Chapter 4A, 4B or 4C).
- Worn or incorrectly adjusted contact breaker points (Chapter 5B).
- Ballasted ignition system fault (Chapter 5B).
- Blocked injector/fuel injection system fault - fuel injected models (Chapter 4B).

### Engine idles erratically

- Air filter element clogged (Chapter 1).
- Vacuum leak at the carburettor/throttle body, inlet manifold or associated hoses (Chapter 4A, 4B or 4C).
- Worn, faulty or incorrectly-gapped spark plugs (Chapter 1).
- Worn or incorrectly adjusted contact breaker points (Chapter 5B).
- Uneven or low cylinder compressions (Chapter 2A).
- Camshaft lobes worn (Chapter 2B).
- Incorrect idle speed and mixture adjustment - carburettor models (Chapter 4A).
- Blocked injector/fuel injection system fault - fuel injected models (Chapter 4B).
- Incorrect valve clearances (Chapter 2A).
- Broken valve spring(s) (Chapter 2B).
- Burnt, sticking or leaking valves (Chapter 2B).
- Worn valve stems or guides (Chapter 2B).
- Worn or damaged pistons, piston rings and bores (Chapter 2B).

### Engine misfires at idle speed

- Worn, faulty or incorrectly-gapped spark plugs (Chapter 1).
- Faulty spark plug HT leads (Chapter 1).
- Worn or incorrectly adjusted contact breaker points (Chapter 5B).
- Incorrect idle speed and mixture adjustment - carburettor models (Chapter 4A).
- Vacuum leak at the carburettor/throttle body, inlet manifold or associated hoses (Chapter 4A, 4B or 4C).
- Blocked injector/fuel injection system fault - fuel-injected models (Chapter 4B).
- Distributor cap cracked or tracking internally (Chapter 1).
- Incorrect valve clearances (Chapter 2A).
- Uneven or low cylinder compressions (Chapter 2A).
- Disconnected, leaking, or perished crankcase ventilation hoses (Chapter 4C).

### Engine misfires throughout the driving speed range

- Fuel filter choked - fuel injected models (Chapter 1).
- Incorrect idle speed and mixture adjustment - carburettor models (Chapter 4A).
- Incorrect ignition timing (Chapter 5B).
- Choke mechanism incorrectly adjusted, worn or sticking - carburettor models (Chapter 4A).



## Engine (continued)

- Worn or incorrectly adjusted contact breaker points (Chapter 5B).
- Fuel pump faulty, or delivery pressure low (Chapter 4A or 4B).
- Fuel tank vent blocked, or fuel pipes restricted (Chapter 4A or 4B).
- Carburettor float chamber flooding (float height incorrect) - carburettor models (Chapter 4A).
- Vacuum leak at the carburettor/throttle body, inlet manifold or associated hoses (Chapter 4A, 4B or 4C).
- Worn, faulty or incorrectly-gapped spark plugs (Chapter 1).
- Faulty spark plug HT leads (Chapter 1).
- Distributor cap cracked or tracking internally (where applicable) (Chapter 1).
- Faulty ignition coil or ignition module (Chapter 5B).
- Incorrect valve clearances (Chapter 2A).
- Uneven or low cylinder compressions (Chapter 2A).
- Blocked injector/fuel injection system fault - fuel injected models (Chapter 4B).

### **Engine hesitates on acceleration**

- Worn, faulty or incorrectly-gapped spark plugs (Chapter 1).
- Vacuum leak at the carburettor/throttle body, inlet manifold or associated hoses (Chapter 4A, 4B or 4C).
- Incorrect idle speed and mixture adjustment - carburettor models (Chapter 4A).
- Choke mechanism incorrectly adjusted, worn or sticking - carburettor models (Chapter 4A).
- Worn or incorrectly adjusted contact breaker points (Chapter 5B).
- Blocked injector/fuel injection system fault - fuel injected models (Chapter 4B).

### **Engine stalls**

- Vacuum leak at the carburettor/throttle body, inlet manifold or associated hoses (Chapter 4A, 4B or 4C).
- Incorrect idle speed and mixture adjustment - carburettor models (Chapter 4A).
- Choke mechanism incorrectly adjusted, worn or sticking - carburettor models (Chapter 4A).
- Carburettor float chamber flooding (float height incorrect) - carburettor models (Chapter 4A).
- Fuel filter choked - fuel injected models (Chapter 1).
- Fuel pump faulty, or delivery pressure low (Chapter 4A or 4B).
- Fuel tank vent blocked, or fuel pipes restricted (Chapter 4A or 4B).
- Blocked injector/fuel injection system fault - fuel-injected models (Chapter 4B).

### **Engine lacks power**

- Timing chain incorrectly fitted (Chapter 2A).
- Incorrect idle speed and mixture adjustment - carburettor models (Chapter 4A).
- Incorrect ignition timing (Chapter 5B).
- Fuel filter choked - fuel-injected models (Chapter 1).
- Fuel pump faulty, or delivery pressure low (Chapter 4A or 4B).
- Incorrect valve clearances (Chapter 2A).
- Uneven or low cylinder compressions (Chapter 2A).
- Worn, faulty or incorrectly-gapped spark plugs (Chapter 1).
- Vacuum leak at the carburettor/throttle body, inlet manifold or associated hoses (Chapter 4A, 4B or 4C).
- Blocked injector/fuel injection system fault - fuel injected models (Chapter 4B).
- Brakes binding (Chapters 1 and 9).
- Clutch slipping (Chapter 6).

### **Engine backfires**

- Timing chain incorrectly fitted (Chapter 2A or 2B).
- Vacuum leak at the carburettor/throttle body, inlet manifold or associated hoses (Chapter 4A, 4B or 4C).
- Incorrect ignition timing (Chapter 5B).
- Blocked carburettor jet(s) or internal passages - carburettor models (Chapter 4A).
- Blocked injector/fuel injection system fault - fuel injected models (Chapter 4B).

### **Oil pressure warning light illuminated with engine running**

- Low oil level, or incorrect oil grade (Chapter 1).
- Worn engine bearings and/or oil pump (Chapter 2B).
- High engine operating temperature (Chapter 3).
- Oil pressure relief valve defective (Chapter 2B).
- Oil pick-up strainer clogged (Chapter 2B).

### **Engine runs-on after switching off**

- Excessive carbon build-up in engine (Chapter 2B).
- Incorrectly adjusted idle speed (Chapter 4A).
- Incorrect ignition timing (Chapter 5B).
- High engine operating temperature (Chapter 3).
- Fuel injection system fault - fuel injected models (Chapter 4B).

### **Engine noises**

#### **Pre-ignition (pinking) or knocking during acceleration or under load**

- Ignition timing incorrect/ignition system fault (Chapters 1 and 5B).
- Incorrect grade of spark plug (Chapter 1).
- Incorrect grade of fuel (Chapter 1).
- Vacuum leak at the carburettor/throttle body, inlet manifold or associated hoses (Chapter 4A, 4B or 4C).
- Excessive carbon build-up in engine (Chapter 2B).
- Blocked injector/fuel injection system fault - fuel injected models (Chapter 4B).

#### **Whistling or wheezing noises**

- Leaking inlet manifold or carburettor/throttle body gasket (Chapter 4A or 4B).
- Leaking exhaust manifold gasket or pipe-to-manifold joint (Chapter 4C).
- Leaking vacuum hose (Chapters 4A, 4B, 4C, 5B and 9).
- Blowing cylinder head gasket (Chapter 2A or 2B).

#### **Tapping or rattling noises**

- Incorrect valve clearances (Chapter 2A).
- Worn timing chain tensioner, valve gear or camshaft (Chapter 2A or 2B).
- Ancillary component fault (water pump, dynamo, alternator, etc) (Chapters 3, 5A, etc).

#### **Knocking or thumping noises**

- Worn big-end bearings (regular heavy knocking, perhaps less under load) (Chapter 2B).
- Worn main bearings (rumbling and knocking, perhaps worsening under load) (Chapter 2B).
- Piston slap (most noticeable when cold) (Chapter 2B).
- Ancillary component fault (water pump, dynamo, alternator, etc) (Chapters 3, 5A, etc).

## 2 Cooling system

### Overheating

- Insufficient coolant in system (“Weekly checks”).
- Thermostat faulty (Chapter 3).
- Radiator core blocked, or grille restricted (Chapter 3).
- Electric cooling fan or thermostwitch faulty - later models (Chapter 3).
- Pressure cap faulty (Chapter 3).
- Blown cylinder head gasket (Chapter 2A or 2B).
- Ignition timing incorrect/ignition system fault (Chapters 1 and 5B).
- Inaccurate temperature gauge sender unit (Chapter 3).
- Airlock in cooling system (Chapter 1).

### Overcooling

- Thermostat faulty (Chapter 3).
- Inaccurate temperature gauge sender unit (Chapter 3).

### External coolant leakage

- Deteriorated or damaged hoses or hose clips (Chapter 1).
- Radiator core or heater matrix leaking (Chapter 3).
- Pressure cap faulty (Chapter 3).
- Water pump seal leaking (Chapter 3).
- Boiling due to overheating (Chapter 3).
- Core plug leaking (Chapter 2B).

### Internal coolant leakage

- Leaking cylinder head gasket (Chapter 2A or 2B).
- Cracked cylinder head or cylinder bore (Chapter 2A or 2B).

### Corrosion

- Infrequent draining and flushing (Chapter 1).
- Incorrect coolant mixture or inappropriate coolant type (Chapter 1).

## 3 Fuel and exhaust systems

### Excessive fuel consumption

- Air filter element dirty or clogged (Chapter 1).
- Incorrect idle speed and mixture adjustment - carburettor models (Chapter 4A).
- Choke cable incorrectly adjusted, or choke sticking - carburettor models (Chapter 4A).
- Fuel injection system fault - fuel injected models (Chapter 4B).
- Ignition timing incorrect/ignition system fault (Chapters 1 and 5B).
- Tyres under-inflated (“Weekly checks”).

### Fuel leakage and/or fuel odour

- Damaged or corroded fuel tank, pipes or connections (Chapter 4A, 4B or 4C).
- Carburettor float chamber flooding (float height incorrect) - carburettor models (Chapter 4A).

### Excessive noise or fumes from exhaust system

- Leaking exhaust system or manifold joints (Chapters 1 and 4C).
- Leaking, corroded or damaged silencers or pipe (Chapters 1 and 4C).
- Broken mountings causing body or suspension contact (Chapter 4C).

## 4 Clutch

### Pedal travels to floor (no pressure or very little resistance)

- Air in clutch hydraulic system (Chapter 6).
- Faulty clutch master cylinder (Chapter 6).
- Faulty clutch slave cylinder (Chapter 6).
- Incorrect clutch return stop adjustment (Chapter 1).
- Incorrect clutch throw-out stop adjustment (Chapter 6).
- Broken clutch release bearing (Chapter 6).
- Broken diaphragm spring in clutch pressure plate (Chapter 6).

### Clutch fails to disengage (unable to select gears)

- Incorrect clutch return stop adjustment (Chapter 1).
- Incorrect clutch throw-out stop adjustment (Chapter 6).
- Clutch disc sticking on primary gear splines (Chapter 6).
- Clutch disc sticking to flywheel or pressure plate (Chapter 6).
- Faulty pressure plate assembly (Chapter 6).
- Clutch release mechanism worn or incorrectly assembled (Chapter 6).

### Clutch slips (engine speed increases, with no increase in vehicle speed)

- Incorrect clutch return stop adjustment (Chapter 1).
- Clutch disc linings excessively worn (Chapter 6).
- Clutch disc linings contaminated with oil or grease (Chapter 6).
- Faulty pressure plate or weak diaphragm spring (Chapter 6).

### Judder as clutch is engaged

- Worn or loose engine or transmission mountings (Chapter 2A).
- Clutch disc linings contaminated with oil or grease (Chapter 6).
- Clutch disc linings excessively worn (Chapter 6).
- Faulty or distorted pressure plate or diaphragm spring (Chapter 6).
- Clutch disc hub or primary gear splines worn (Chapter 6).

### Noise when depressing or releasing clutch pedal

- Worn clutch release bearing (Chapter 6).
- Worn or dry clutch pedal bushes (Chapter 6).
- Faulty pressure plate assembly (Chapter 6).
- Pressure plate diaphragm spring broken (Chapter 6).

## 5 Manual transmission

### Noisy in neutral with engine running

- Transfer gear bearings worn (noise apparent with clutch pedal released, but not when depressed) (Chapter 7A).\*
- Clutch release bearing worn (noise apparent with clutch pedal depressed, possibly less when released) (Chapter 6).

### Noisy in one particular gear

- Worn, damaged or chipped gear teeth (Chapter 7A).\*

### Difficulty engaging gears

- Clutch fault (Chapter 6).
- Worn or damaged gear linkage (Chapter 7A).
- Worn synchroniser units (Chapter 7A).\*

### Jumps out of gear

- Worn or damaged gear linkage (Chapter 7A).
- Incorrectly-adjusted gear linkage (Chapter 7A).
- Worn synchroniser units (Chapter 7A).\*
- Worn selector forks (Chapter 7A).\*

### Vibration

- Lack of oil (Chapter 1).
- Worn bearings (Chapter 7A).\*

### Lubricant leaks

- Leaking differential output (driveshaft) oil seal (Chapter 7A).
- Leaking housing joint (Chapter 2B or 7A).\*

*\*Although the corrective action necessary to remedy the symptoms described is beyond the scope of the home mechanic, the above information should be helpful in isolating the cause of the condition, so that the owner can communicate clearly with a professional mechanic.*

## 6 Automatic transmission

**Note:** Due to the complexity of the automatic transmission, it is difficult for the home mechanic to properly diagnose and service this unit. For problems other than the following, the vehicle should be taken to a dealer service department or automatic transmission specialist. Do not be too hasty in removing the transmission if a fault is suspected, as most of the testing is carried out with the unit still fitted.

### Fluid leakage

- To determine the source of a leak, first remove all built-up dirt and grime from the transmission housing and surrounding areas using a degreasing agent, or by steam-cleaning. Drive the vehicle at low speed, so airflow will not blow the leak far from its source. Raise and support the vehicle, and determine where the leak is coming from. The following are common areas of leakage:
  - a) Leaking differential output (driveshaft) oil seal (Chapter 7B).
  - b) Leaking housing joint (Chapter 2B or 7B).
  - c) Leaking selector transverse rod oil seal (Chapter 7B).

### General gear selection problems

- Chapter 7B deals with checking and adjusting the selector cable on automatic transmissions. The following are common problems which may be caused by a poorly-adjusted cable:

- a) Engine starting in gears other than Neutral.
- b) Indicator panel indicating a gear other than the one actually being used.
- c) Vehicle moves when in Park or Neutral.
- d) Poor gear shift quality or erratic gear changes.

### Transmission will not downshift (kickdown) with accelerator pedal fully depressed

- Low engine/transmission oil level (Chapter 1).
- Incorrect selector cable adjustment (Chapter 7B).

### Engine will not start in any gear, or starts in gears other than Neutral

- Incorrect starter/inhibitor switch adjustment (Chapter 7B).
- Incorrect selector cable adjustment (Chapter 7B).

### Transmission slips, shifts roughly, is noisy, or has no drive in forward or reverse gears

- There are many probable causes for the above problems, which can really only be accurately diagnosed using pressure gauges in conjunction with a step-by-step diagnostic procedure. Problems of this nature must, therefore, be referred to a dealer or automatic transmission specialist.

## 7 Driveshafts

### Clicking or knocking noise on turns (at slow speed on full-lock)

- Lack of constant velocity joint lubricant, possibly due to damaged gaiters (Chapter 8).
- Worn outer constant velocity joint (Chapter 8).

### Vibration when accelerating or decelerating

- Worn inner constant velocity joint (Chapter 8).
- Bent or distorted driveshaft (Chapter 8).

## 8 Braking system

**Note:** Before assuming that a brake problem exists, make sure that the tyres are in good condition and correctly inflated, that the front wheel alignment is correct, and that the vehicle is not loaded with weight in an unequal manner.

### Vehicle pulls to one side under braking

- Worn, defective, damaged or contaminated brake shoes/pads on one side (Chapters 1 and 9).
- Seized or partially-seized front wheel cylinder piston or brake caliper piston (Chapters 1 and 9).
- A mixture of brake shoe/ pad lining materials fitted between sides (Chapters 1 and 9).
- Brake backplate or caliper mounting bolts loose (Chapter 9).
- Worn or damaged steering or suspension components (Chapters 1 and 10).

### Noise (grinding or high-pitched squeal) when brakes applied

- Brake shoe or pad friction lining material worn down to metal backing (Chapters 1 and 9).
- Excessive corrosion of brake drum or disc. (May be apparent after the vehicle has been standing for some time (Chapters 1 and 9).

### Excessive brake pedal travel

- Incorrect drum brake adjustment (Chapter 1).
- Faulty master cylinder (Chapter 9).
- Air in hydraulic system (Chapter 9).
- Faulty vacuum servo unit - where fitted (Chapter 9).

### Brake pedal feels spongy when depressed

- Air in hydraulic system (Chapter 9).
- Deteriorated flexible rubber brake hoses (Chapters 1 and 9).

## 9 Suspension and steering systems

**Note:** Before diagnosing suspension or steering faults, be sure that the trouble is not due to incorrect tyre pressures, mixtures of tyre types, or binding brakes.

### Vehicle pulls to one side

- Defective tyre ("Weekly checks").
- Excessive wear in suspension or steering components (Chapters 1 and 10).
- Incorrect front wheel alignment (Chapter 10).
- Worn or broken subframe mountings (Chapter 10).
- Accident damage to steering or suspension components (Chapter 1).

### Wheel wobble and vibration

- Front roadwheels out of balance (vibration felt mainly through the steering wheel) (Chapters 1 and 10).
- Rear roadwheels out of balance (vibration felt throughout the vehicle) (Chapters 1 and 10).
- Roadwheels damaged or distorted (Chapters 1 and 10).
- Defective tyre ("Weekly checks").
- Worn steering or suspension joints, bushes or components (Chapters 1 and 10).
- Wheel nuts loose (Chapters 1 and 10).

### Excessive pitching and/or rolling around corners, or during braking

- Defective shock absorbers - rubber cone suspension models (Chapter 10).
- Incorrect vehicle ride height - Hydrolastic suspension models (Chapter 10).
- Worn or damaged suspension component or mounting (Chapter 10).

- Master cylinder mounting nuts loose (Chapter 9).
- Faulty master cylinder (Chapter 9).

### Excessive brake pedal effort required to stop vehicle

- Faulty vacuum servo unit - where fitted (Chapter 9).
- Disconnected, damaged or insecure brake servo vacuum hose (Chapter 9).
- Primary or secondary hydraulic circuit failure (Chapter 9).
- Seized wheel cylinder or brake caliper piston(s) (Chapter 9).
- Brake shoes or pads incorrectly fitted (Chapters 1 and 9).
- Incorrect grade of brake shoes or pads fitted (Chapters 1 and 9).
- Brake shoe linings or pads contaminated (Chapters 1 and 9).

### Judder felt through brake pedal or steering wheel when braking

- Excessive run-out or distortion of drums/discs (Chapters 1 and 9).
- Brake shoe or pad linings worn (Chapters 1 and 9).
- Brake backplate or caliper mounting bolts loose (Chapter 9).
- Wear in suspension or steering components or mountings (Chapters 1 and 10).

### Brakes binding

- Incorrect drum brake adjustment (Chapter 1).
- Seized wheel cylinder or brake caliper piston(s) (Chapter 9).
- Incorrectly-adjusted handbrake mechanism (Chapter 9).
- Seized handbrake cable moving sectors (Chapter 9).
- Faulty master cylinder (Chapter 9).

### Rear wheels locking under normal braking

- Rear brake shoe linings contaminated (Chapters 1 and 9).
- Faulty brake pressure regulating valve or reducing valve (Chapter 9).

### Wandering or general instability

- Incorrect front wheel alignment (Chapter 10).
- Worn steering or suspension joints, bushes or components (Chapters 1 and 10).
- Roadwheels out of balance (Chapters 1 and 10).
- Defective tyre ("Weekly checks").
- Wheel nuts loose (Chapters 1 and 10).
- Defective shock absorbers - rubber cone suspension models (Chapter 10).
- Incorrect vehicle ride height - Hydrolastic suspension models (Chapter 10).

### Excessively-stiff steering

- Lack of steering gear lubricant (Chapter 10).
- Seized tie-rod or suspension balljoint (Chapters 1 and 10).
- Incorrect front wheel alignment (Chapter 10).
- Steering rack or column bent or damaged (Chapter 10).

### Excessive play in steering

- Worn steering tie-rod balljoints (Chapters 1 and 10).
- Loose steering column clamp bolt (Chapter 10).
- Worn rack-and-pinion steering gear (Chapter 10).
- Worn steering or suspension joints, bushes or components (Chapters 1 and 10).

### Tyre wear excessive

#### Tyres worn on inside or outside edges

- Tyres under-inflated (wear on both edges) ("Weekly checks").
- Incorrect camber or castor angles (wear on one edge only) (Chapter 10).



## 9 Suspension and steering systems (continued)

- Worn steering or suspension joints, bushes or components (Chapters 1 and 10).
- Worn or broken subframe mountings (Chapter 10).
- Incorrect vehicle ride height - Hydrolastic suspension models (Chapter 10).
- Excessively-hard cornering.
- Accident damage.

### Tyre treads exhibit feathered edges

- Incorrect toe setting (Chapter 10).

### Tyres worn in centre of tread

- Tyres over-inflated ("Weekly checks").

### Tyres worn on inside and outside edges

- Tyres under-inflated ("Weekly checks").

### Tyres worn unevenly

- Tyres/wheels out of balance (Chapter 1).
- Excessive wheel or tyre run-out (Chapter 1).
- Defective tyre ("Weekly checks").
- Defective shock absorbers - rubber cone suspension models (Chapter 10).

## 10 Electrical system

**Note:** For problems associated with the starting system, refer to the faults listed under "Engine" earlier in this Section.

### Battery will not hold a charge for more than a few days

- Battery defective internally (Chapter 5A).
- Battery terminal connections loose or corroded ("Weekly checks").
- Fan belt worn or incorrectly adjusted (Chapter 1).
- Dynamo/alternator not charging at correct output (Chapter 5A).
- Alternator or voltage regulator faulty (Chapter 5A).
- Short-circuit causing continual battery drain (Chapters 5A and 12).

### Ignition/no-charge warning light remains illuminated with engine running

- Fan belt worn, incorrectly adjusted or broken (Chapter 1).
- Dynamo/alternator brushes worn, sticking, or dirty (Chapter 5A).
- Dynamo/alternator brush springs weak or broken (Chapter 5A).
- Internal fault in alternator or voltage regulator (Chapter 5A).
- Broken, disconnected, or loose wiring in charging circuit (Chapter 5A).

### Ignition/no-charge warning light fails to come on

- Warning light bulb blown (Chapter 12).
- Broken, disconnected, or loose wiring in warning light circuit (Chapter 12).
- Alternator faulty (Chapter 5A).

### Lights inoperative

- Bulb blown (Chapter 12).
- Corrosion of bulb or bulbholder contacts (Chapter 12).
- Blown fuse (Chapter 12).
- Faulty relay (Chapter 12).
- Broken, loose, or disconnected wiring (Chapter 12).
- Faulty switch (Chapter 12).

### Instrument readings inaccurate or erratic

#### Instrument readings increase with engine speed

- Faulty voltage stabiliser (Chapter 12).

#### Fuel or temperature gauges give no reading

- Faulty gauge sender unit (Chapters 3, 4A or 4B).
- Wiring open-circuit (Chapter 12).
- Faulty gauge (Chapter 12).

#### Fuel or temperature gauges give continuous maximum reading

- Faulty gauge sender unit (Chapters 3, 4A or 4B).
- Wiring short-circuit (Chapter 12).
- Faulty gauge (Chapter 12).

### Horn inoperative, or unsatisfactory in operation

#### Horn operates all the time

- Horn push either earthed or stuck down (Chapter 12).

- Horn cable-to-horn push earthed (Chapter 12).

#### Horn fails to operate

- Blown fuse (Chapter 12).
- Cable or cable connections loose, broken or disconnected (Chapter 12).
- Faulty horn (Chapter 12).

#### Horn emits intermittent or unsatisfactory sound

- Cable connections loose (Chapter 12).
- Horn mountings loose (Chapter 12).
- Faulty horn (Chapter 12).

### Windscreen wipers inoperative, or unsatisfactory in operation

#### Wipers fail to operate, or operate very slowly

- Wiper blades stuck to screen, or linkage seized or binding ("Weekly checks" and Chapter 12).
- Blown fuse (Chapter 12).
- Cable or cable connections loose, broken or disconnected (Chapter 12).
- Faulty relay (Chapter 12).
- Faulty wiper motor (Chapter 12).

#### Wiper blades sweep over too large or too small an area of the glass

- Wiper arms incorrectly positioned on spindles (Chapter 12).
- Excessive wear of wiper linkage (Chapter 12).
- Wiper motor or linkage mountings loose or insecure (Chapter 12).

#### Wiper blades fail to clean the glass effectively

- Wiper blade rubbers worn or perished ("Weekly checks").
- Wiper arm tension springs broken, or arm pivots seized (Chapter 12).
- Insufficient windscreen washer additive to adequately remove road film ("Weekly checks").

### Windscreen washers inoperative, or unsatisfactory in operation

#### One or more washer jets inoperative

- Blocked washer jet (Chapter 1).
- Disconnected, kinked or restricted fluid hose (Chapter 12).
- Insufficient fluid in washer reservoir (Chapter 1).

#### Washer pump fails to operate

- Broken or disconnected wiring or connections (Chapter 12).
- Blown fuse (Chapter 12).
- Faulty washer switch (Chapter 12).
- Faulty washer pump (Chapter 12).

#### Washer pump runs for some time before fluid is emitted from jets

- Faulty one-way valve in fluid supply hose (Chapter 12).

Whenever servicing, repair or overhaul work is carried out on the car or its components, observe the following procedures and instructions. This will assist in carrying out the operation efficiently and to a professional standard of workmanship.

## Joint mating faces and gaskets

When separating components at their mating faces, never insert screwdrivers or similar implements into the joint between the faces in order to prise them apart. This can cause severe damage which results in oil leaks, coolant leaks, etc upon reassembly. Separation is usually achieved by tapping along the joint with a soft-faced hammer in order to break the seal. However, note that this method may not be suitable where dowels are used for component location.

Where a gasket is used between the mating faces of two components, a new one must be fitted on reassembly; fit it dry unless otherwise stated in the repair procedure. Make sure that the mating faces are clean and dry, with all traces of old gasket removed. When cleaning a joint face, use a tool which is unlikely to score or damage the face, and remove any burrs or nicks with an oilstone or fine file.

Make sure that tapped holes are cleaned with a pipe cleaner, and keep them free of jointing compound, if this is being used, unless specifically instructed otherwise.

Ensure that all orifices, channels or pipes are clear, and blow through them, preferably using compressed air.

## Oil seals

Oil seals can be removed by levering them out with a wide flat-bladed screwdriver or similar implement. Alternatively, a number of self-tapping screws may be screwed into the seal, and these used as a purchase for pliers or some similar device in order to pull the seal free.

Whenever an oil seal is removed from its working location, either individually or as part of an assembly, it should be renewed.

The very fine sealing lip of the seal is easily damaged, and will not seal if the surface it contacts is not completely clean and free from scratches, nicks or grooves. If the original sealing surface of the component cannot be restored, and the manufacturer has not made provision for slight relocation of the seal relative to the sealing surface, the component should be renewed.

Protect the lips of the seal from any surface which may damage them in the course of fitting. Use tape or a conical sleeve where possible. Lubricate the seal lips with oil before fitting and, on dual-lipped seals, fill the space between the lips with grease.

Unless otherwise stated, oil seals must be fitted with their sealing lips toward the lubricant to be sealed.

Use a tubular drift or block of wood of the appropriate size to install the seal and, if the seal housing is shouldered, drive the seal down to the shoulder. If the seal housing is

unshouldered, the seal should be fitted with its face flush with the housing top face (unless otherwise instructed).

## Screw threads and fastenings

Seized nuts, bolts and screws are quite a common occurrence where corrosion has set in, and the use of penetrating oil or releasing fluid will often overcome this problem if the offending item is soaked for a while before attempting to release it. The use of an impact driver may also provide a means of releasing such stubborn fastening devices, when used in conjunction with the appropriate screwdriver bit or socket. If none of these methods works, it may be necessary to resort to the careful application of heat, or the use of a hacksaw or nut splitter device.

Studs are usually removed by locking two nuts together on the threaded part, and then using a spanner on the lower nut to unscrew the stud. Studs or bolts which have broken off below the surface of the component in which they are mounted can sometimes be removed using a stud extractor. Always ensure that a blind tapped hole is completely free from oil, grease, water or other fluid before installing the bolt or stud. Failure to do this could cause the housing to crack due to the hydraulic action of the bolt or stud as it is screwed in.

When tightening a castellated nut to accept a split pin, tighten the nut to the specified torque, where applicable, and then tighten further to the next split pin hole. Never slacken the nut to align the split pin hole, unless stated in the repair procedure.

When checking or retightening a nut or bolt to a specified torque setting, slacken the nut or bolt by a quarter of a turn, and then retighten to the specified setting. However, this should not be attempted where angular tightening has been used.

For some screw fastenings, notably cylinder head bolts or nuts, torque wrench settings are no longer specified for the latter stages of tightening, "angle-tightening" being called up instead. Typically, a fairly low torque wrench setting will be applied to the bolts/nuts in the correct sequence, followed by one or more stages of tightening through specified angles.

## Locknuts, locktabs and washers

Any fastening which will rotate against a component or housing during tightening should always have a washer between it and the relevant component or housing.

Spring or split washers should always be renewed when they are used to lock a critical component such as a big-end bearing retaining bolt or nut. Locktabs which are folded over to retain a nut or bolt should always be renewed.

Self-locking nuts can be re-used in non-critical areas, providing resistance can be felt when the locking portion passes over the bolt or stud thread. However, it should be noted that self-locking stiffnuts tend to lose their

effectiveness after long periods of use, and should then be renewed as a matter of course.

Split pins must always be replaced with new ones of the correct size for the hole.

When thread-locking compound is found on the threads of a fastener which is to be re-used, it should be cleaned off with a wire brush and solvent, and fresh compound applied on reassembly.

## Special tools

Some repair procedures in this manual entail the use of special tools such as a press, two or three-legged pullers, spring compressors, etc. Wherever possible, suitable readily-available alternatives to the manufacturer's special tools are described, and are shown in use. In some instances, where no alternative is possible, it has been necessary to resort to the use of a manufacturer's tool, and this has been done for reasons of safety as well as the efficient completion of the repair operation. Unless you are highly-skilled and have a thorough understanding of the procedures described, never attempt to bypass the use of any special tool when the procedure described specifies its use. Not only is there a very great risk of personal injury, but expensive damage could be caused to the components involved.

## Environmental considerations

When disposing of used engine oil, brake fluid, antifreeze, etc, give due consideration to any detrimental environmental effects. Do not, for instance, pour any of the above liquids down drains into the general sewage system, or onto the ground to soak away. Many local council refuse tips provide a facility for waste oil disposal, as do some garages. If none of these facilities are available, consult your local Environmental Health Department, or the National Rivers Authority, for further advice.

With the universal tightening-up of legislation regarding the emission of environmentally-harmful substances from motor vehicles, most vehicles have tamperproof devices fitted to the main adjustment points of the fuel system. These devices are primarily designed to prevent unqualified persons from adjusting the fuel/air mixture, with the chance of a consequent increase in toxic emissions. If such devices are found during servicing or overhaul, they should, wherever possible, be renewed or refitted in accordance with the manufacturer's requirements or current legislation.



OIL BANK LINE  
0800 66 33 66

**Note: It is antisocial and illegal to dump oil down the drain. To find the location of your local oil recycling bank, call this number free.**

**A**

**ABS (Anti-lock brake system)** A system, usually electronically controlled, that senses incipient wheel lockup during braking and relieves hydraulic pressure at wheels that are about to skid.

**Air bag** An inflatable bag hidden in the steering wheel (driver's side) or the dash or glovebox (passenger side). In a head-on collision, the bags inflate, preventing the driver and front passenger from being thrown forward into the steering wheel or windshield.

**Air cleaner** A metal or plastic housing, containing a filter element, which removes dust and dirt from the air being drawn into the engine.

**Air filter element** The actual filter in an air cleaner system, usually manufactured from pleated paper and requiring renewal at regular intervals.

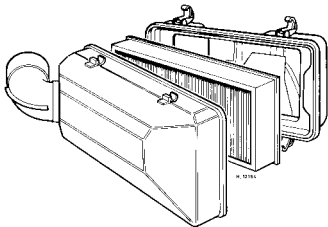

Air filter

**Allen key** A hexagonal wrench which fits into a recessed hexagonal hole.

**Alligator clip** A long-nosed spring-loaded metal clip with meshing teeth. Used to make temporary electrical connections.

**Alternator** A component in the electrical system which converts mechanical energy from a drivebelt into electrical energy to charge the battery and to operate the starting system, ignition system and electrical accessories.

**Ampere (amp)** A unit of measurement for the flow of electric current. One amp is the amount of current produced by one volt acting through a resistance of one ohm.

**Anaerobic sealer** A substance used to prevent bolts and screws from loosening. Anaerobic means that it does not require oxygen for activation. The Loctite brand is widely used.

**Antifreeze** A substance (usually ethylene glycol) mixed with water, and added to a vehicle's cooling system, to prevent freezing of the coolant in winter. Antifreeze also contains chemicals to inhibit corrosion and the formation of rust and other deposits that would tend to clog the radiator and coolant passages and reduce cooling efficiency.

**Anti-seize compound** A coating that reduces the risk of seizing on fasteners that are subjected to high temperatures, such as exhaust manifold bolts and nuts.

**Asbestos** A natural fibrous mineral with great heat resistance, commonly used in the composition of brake friction materials.

Asbestos is a health hazard and the dust created by brake systems should never be inhaled or ingested.

**Axle** A shaft on which a wheel revolves, or which revolves with a wheel. Also, a solid beam that connects the two wheels at one end of the vehicle. An axle which also transmits power to the wheels is known as a live axle.

**Axleshaft** A single rotating shaft, on either side of the differential, which delivers power from the final drive assembly to the drive wheels. Also called a driveshaft or a halfshaft.

**B**

**Ball bearing** An anti-friction bearing consisting of a hardened inner and outer race with hardened steel balls between two races.

**Bearing** The curved surface on a shaft or in a bore, or the part assembled into either, that permits relative motion between them with minimum wear and friction.



Bearing

**Big-end bearing** The bearing in the end of the connecting rod that's attached to the crankshaft.

**Bleed nipple** A valve on a brake wheel cylinder, caliper or other hydraulic component that is opened to purge the hydraulic system of air. Also called a bleed screw.

**Brake bleeding** Procedure for removing air from lines of a hydraulic brake system.

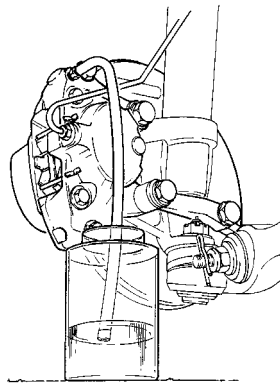

Brake bleeding

**Brake disc** The component of a disc brake that rotates with the wheels.

**Brake drum** The component of a drum brake that rotates with the wheels.

**Brake linings** The friction material which contacts the brake disc or drum to retard the vehicle's speed. The linings are bonded or riveted to the brake pads or shoes.

**Brake pads** The replaceable friction pads that pinch the brake disc when the brakes are applied. Brake pads consist of a friction material bonded or riveted to a rigid backing plate.

**Brake shoe** The crescent-shaped carrier to which the brake linings are mounted and which forces the lining against the rotating drum during braking.

**Braking systems** For more information on braking systems, consult the *Haynes Automotive Brake Manual*.

**Breaker bar** A long socket wrench handle providing greater leverage.

**Bulkhead** The insulated partition between the engine and the passenger compartment.

**C**

**Caliper** The non-rotating part of a disc-brake assembly that straddles the disc and carries the brake pads. The caliper also contains the hydraulic components that cause the pads to pinch the disc when the brakes are applied. A caliper is also a measuring tool that can be set to measure inside or outside dimensions of an object.

**Camshaft** A rotating shaft on which a series of cam lobes operate the valve mechanisms. The camshaft may be driven by gears, by sprockets and chain or by sprockets and a belt.

**Canister** A container in an evaporative emission control system; contains activated charcoal granules to trap vapours from the fuel system.



Canister

**Carburettor** A device which mixes fuel with air in the proper proportions to provide a desired power output from a spark ignition internal combustion engine.

**Castellated** Resembling the parapets along the top of a castle wall. For example, a castellated balljoint stud nut.

**Castor** In wheel alignment, the backward or forward tilt of the steering axis. Castor is positive when the steering axis is inclined rearward at the top.

**Catalytic converter** A silencer-like device in the exhaust system which converts certain pollutants in the exhaust gases into less harmful substances.

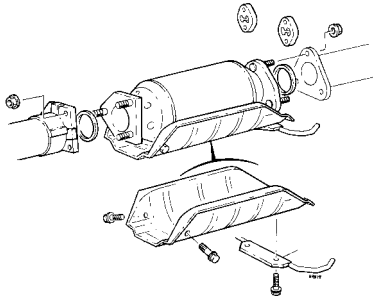

*Catalytic converter*

**Circlip** A ring-shaped clip used to prevent endwise movement of cylindrical parts and shafts. An internal circlip is installed in a groove in a housing; an external circlip fits into a groove on the outside of a cylindrical piece such as a shaft.

**Clearance** The amount of space between two parts. For example, between a piston and a cylinder, between a bearing and a journal, etc.

**Coil spring** A spiral of elastic steel found in various sizes throughout a vehicle, for example as a springing medium in the suspension and in the valve train.

**Compression** Reduction in volume, and increase in pressure and temperature, of a gas, caused by squeezing it into a smaller space.

**Compression ratio** The relationship between cylinder volume when the piston is at top dead centre and cylinder volume when the piston is at bottom dead centre.

**Constant velocity (CV) joint** A type of universal joint that cancels out vibrations caused by driving power being transmitted through an angle.

**Core plug** A disc or cup-shaped metal device inserted in a hole in a casting through which core was removed when the casting was formed. Also known as a freeze plug or expansion plug.

**Crankcase** The lower part of the engine block in which the crankshaft rotates.

**Crankshaft** The main rotating member, or shaft, running the length of the crankcase, with offset "throws" to which the connecting rods are attached.

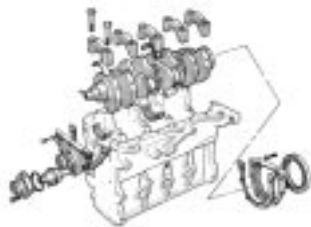

*Crankshaft assembly*

**Crocodile clip** See Alligator clip

## D

**Diagnostic code** Code numbers obtained by accessing the diagnostic mode of an engine management computer. This code can be used to determine the area in the system where a malfunction may be located.

**Disc brake** A brake design incorporating a rotating disc onto which brake pads are squeezed. The resulting friction converts the energy of a moving vehicle into heat.

**Double-overhead cam (DOHC)** An engine that uses two overhead camshafts, usually one for the intake valves and one for the exhaust valves.

**Drivebelt(s)** The belt(s) used to drive accessories such as the alternator, water pump, power steering pump, air conditioning compressor, etc. off the crankshaft pulley.

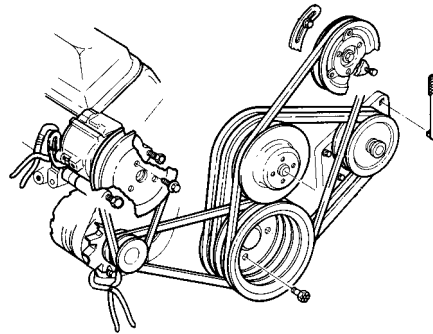

*Accessory drivebelts*

**Driveshaft** Any shaft used to transmit motion. Commonly used when referring to the axleshafts on a front wheel drive vehicle.

**Drum brake** A type of brake using a drum-shaped metal cylinder attached to the inner surface of the wheel. When the brake pedal is pressed, curved brake shoes with friction linings press against the inside of the drum to slow or stop the vehicle.

## E

**EGR valve** A valve used to introduce exhaust gases into the intake air stream.

**Electronic control unit (ECU)** A computer which controls (for instance) ignition and fuel injection systems, or an anti-lock braking system. For more information refer to the *Haynes Automotive Electrical and Electronic Systems Manual*.

**Electronic Fuel Injection (EFI)** A computer controlled fuel system that distributes fuel through an injector located in each intake port of the engine.

**Emergency brake** A braking system, independent of the main hydraulic system, that can be used to slow or stop the vehicle if the primary brakes fail, or to hold the vehicle stationary even though the brake pedal isn't depressed. It usually consists of a hand lever that actuates either front or rear brakes mechanically through a series of cables and linkages. Also known as a handbrake or parking brake.

**Endfloat** The amount of lengthwise movement between two parts. As applied to a crankshaft, the distance that the crankshaft can move forward and back in the cylinder block.

**Engine management system (EMS)** A computer controlled system which manages the fuel injection and the ignition systems in an integrated fashion.

**Exhaust manifold** A part with several passages through which exhaust gases leave the engine combustion chambers and enter the exhaust pipe.

## F

**Fan clutch** A viscous (fluid) drive coupling device which permits variable engine fan speeds in relation to engine speeds.

**Feeler blade** A thin strip or blade of hardened steel, ground to an exact thickness, used to check or measure clearances between parts.



*Feeler blade*

**Firing order** The order in which the engine cylinders fire, or deliver their power strokes, beginning with the number one cylinder.

**Flywheel** A heavy spinning wheel in which energy is absorbed and stored by means of momentum. On cars, the flywheel is attached to the crankshaft to smooth out firing impulses.

**Free play** The amount of travel before any action takes place. The "looseness" in a linkage, or an assembly of parts, between the initial application of force and actual movement. For example, the distance the brake pedal moves before the pistons in the master cylinder are actuated.

**Fuse** An electrical device which protects a circuit against accidental overload. The typical fuse contains a soft piece of metal which is calibrated to melt at a predetermined current flow (expressed as amps) and break the circuit.

**Fusible link** A circuit protection device consisting of a conductor surrounded by heat-resistant insulation. The conductor is smaller than the wire it protects, so it acts as the weakest link in the circuit. Unlike a blown fuse, a failed fusible link must frequently be cut from the wire for replacement.



**G**

**Gap** The distance the spark must travel in jumping from the centre electrode to the side electrode in a spark plug. Also refers to the spacing between the points in a contact breaker assembly in a conventional points-type ignition, or to the distance between the reluctor or rotor and the pickup coil in an electronic ignition.



*Adjusting spark plug gap*

**Gasket** Any thin, soft material - usually cork, cardboard, asbestos or soft metal - installed between two metal surfaces to ensure a good seal. For instance, the cylinder head gasket seals the joint between the block and the cylinder head.

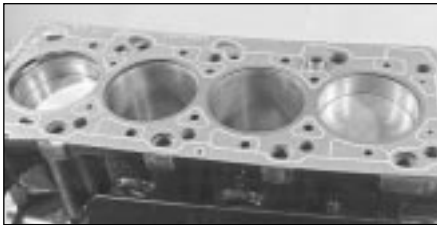

*Gasket*

**Gauge** An instrument panel display used to monitor engine conditions. A gauge with a movable pointer on a dial or a fixed scale is an analogue gauge. A gauge with a numerical readout is called a digital gauge.

**H**

**Halfshaft** A rotating shaft that transmits power from the final drive unit to a drive wheel, usually when referring to a live rear axle.

**Harmonic balancer** A device designed to reduce torsion or twisting vibration in the crankshaft. May be incorporated in the crankshaft pulley. Also known as a vibration damper.

**Hone** An abrasive tool for correcting small irregularities or differences in diameter in an engine cylinder, brake cylinder, etc.

**Hydraulic tappet** A tappet that utilises hydraulic pressure from the engine's lubrication system to maintain zero clearance (constant contact with both camshaft and valve stem). Automatically adjusts to variation in valve stem length. Hydraulic tappets also reduce valve noise.

**I**

**Ignition timing** The moment at which the spark plug fires, usually expressed in the number of crankshaft degrees before the piston reaches the top of its stroke.

**Inlet manifold** A tube or housing with passages through which flows the air-fuel mixture (carburettor vehicles and vehicles with throttle body injection) or air only (port fuel-injected vehicles) to the port openings in the cylinder head.

**J**

**Jump start** Starting the engine of a vehicle with a discharged or weak battery by attaching jump leads from the weak battery to a charged or helper battery.

**L**

**Load Sensing Proportioning Valve (LSPV)** A brake hydraulic system control valve that works like a proportioning valve, but also takes into consideration the amount of weight carried by the rear axle.

**Locknut** A nut used to lock an adjustment nut, or other threaded component, in place. For example, a locknut is employed to keep the adjusting nut on the rocker arm in position.

**Lockwasher** A form of washer designed to prevent an attaching nut from working loose.

**M**

**MacPherson strut** A type of front suspension system devised by Earle MacPherson at Ford of England. In its original form, a simple lateral link with the anti-roll bar creates the lower control arm. A long strut - an integral coil spring and shock absorber - is mounted between the body and the steering knuckle. Many modern so-called MacPherson strut systems use a conventional lower A-arm and don't rely on the anti-roll bar for location.

**Multimeter** An electrical test instrument with the capability to measure voltage, current and resistance.

**N**

**NOx** Oxides of Nitrogen. A common toxic pollutant emitted by petrol and diesel engines at higher temperatures.

**O**

**Ohm** The unit of electrical resistance. One volt applied to a resistance of one ohm will produce a current of one amp.

**Ohmmeter** An instrument for measuring electrical resistance.

**O-ring** A type of sealing ring made of a special rubber-like material; in use, the O-ring is compressed into a groove to provide the sealing action.

**Overhead cam (ohc) engine** An engine with the camshaft(s) located on top of the cylinder head(s).

**Overhead valve (ohv) engine** An engine with the valves located in the cylinder head, but with the camshaft located in the engine block.

**Oxygen sensor** A device installed in the engine exhaust manifold, which senses the oxygen content in the exhaust and converts this information into an electric current. Also called a Lambda sensor.

**P**

**Phillips screw** A type of screw head having a cross instead of a slot for a corresponding type of screwdriver.

**Plastigage** A thin strip of plastic thread, available in different sizes, used for measuring clearances. For example, a strip of Plastigage is laid across a bearing journal. The parts are assembled and dismantled; the width of the crushed strip indicates the clearance between journal and bearing.



*Plastigage*

**Propeller shaft** The long hollow tube with universal joints at both ends that carries power from the transmission to the differential on front-engined rear wheel drive vehicles.

**Proportioning valve** A hydraulic control valve which limits the amount of pressure to the rear brakes during panic stops to prevent wheel lock-up.

**R**

**Rack-and-pinion steering** A steering system with a pinion gear on the end of the steering shaft that mates with a rack (think of a geared wheel opened up and laid flat). When the steering wheel is turned, the pinion turns, moving the rack to the left or right. This movement is transmitted through the track rods to the steering arms at the wheels.

**Radiator** A liquid-to-air heat transfer device designed to reduce the temperature of the coolant in an internal combustion engine cooling system.

**Refrigerant** Any substance used as a heat transfer agent in an air-conditioning system. R-12 has been the principle refrigerant for many years; recently, however, manufacturers have begun using R-134a, a non-CFC substance that is considered less harmful to the ozone in the upper atmosphere.

**Rocker arm** A lever arm that rocks on a shaft or pivots on a stud. In an overhead valve engine, the rocker arm converts the upward movement of the pushrod into a downward movement to open a valve.

**Rotor** In a distributor, the rotating device inside the cap that connects the centre electrode and the outer terminals as it turns, distributing the high voltage from the coil secondary winding to the proper spark plug. Also, that part of an alternator which rotates inside the stator. Also, the rotating assembly of a turbocharger, including the compressor wheel, shaft and turbine wheel.

**Runout** The amount of wobble (in-and-out movement) of a gear or wheel as it's rotated. The amount a shaft rotates "out-of-true." The out-of-round condition of a rotating part.

## S

**Sealant** A liquid or paste used to prevent leakage at a joint. Sometimes used in conjunction with a gasket.

**Sealed beam lamp** An older headlight design which integrates the reflector, lens and filaments into a hermetically-sealed one-piece unit. When a filament burns out or the lens cracks, the entire unit is simply replaced.

**Serpentine drivebelt** A single, long, wide accessory drivebelt that's used on some newer vehicles to drive all the accessories, instead of a series of smaller, shorter belts. Serpentine drivebelts are usually tensioned by an automatic tensioner.

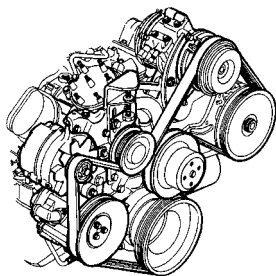

Serpentine drivebelt

**Shim** Thin spacer, commonly used to adjust the clearance or relative positions between two parts. For example, shims inserted into or under bucket tappets control valve clearances. Clearance is adjusted by changing the thickness of the shim.

**Slide hammer** A special puller that screws into or hooks onto a component such as a shaft or bearing; a heavy sliding handle on the shaft bottoms against the end of the shaft to knock the component free.

**Sprocket** A tooth or projection on the periphery of a wheel, shaped to engage with a chain or drivebelt. Commonly used to refer to the sprocket wheel itself.

**Starter inhibitor switch** On vehicles with an automatic transmission, a switch that prevents starting if the vehicle is not in Neutral or Park.

**Strut** See MacPherson strut.

## T

**Tappet** A cylindrical component which transmits motion from the cam to the valve stem, either directly or via a pushrod and rocker arm. Also called a cam follower.

**Thermostat** A heat-controlled valve that regulates the flow of coolant between the cylinder block and the radiator, so maintaining optimum engine operating temperature. A thermostat is also used in some air cleaners in which the temperature is regulated.

**Thrust bearing** The bearing in the clutch assembly that is moved in to the release levers by clutch pedal action to disengage the clutch. Also referred to as a release bearing.

**Timing belt** A toothed belt which drives the camshaft. Serious engine damage may result if it breaks in service.

**Timing chain** A chain which drives the camshaft.

**Toe-in** The amount the front wheels are closer together at the front than at the rear. On rear wheel drive vehicles, a slight amount of toe-in is usually specified to keep the front wheels running parallel on the road by offsetting other forces that tend to spread the wheels apart.

**Toe-out** The amount the front wheels are closer together at the rear than at the front. On front wheel drive vehicles, a slight amount of toe-out is usually specified.

**Tools** For full information on choosing and using tools, refer to the *Haynes Automotive Tools Manual*.

**Tracer** A stripe of a second colour applied to a wire insulator to distinguish that wire from another one with the same colour insulator.

**Tune-up** A process of accurate and careful adjustments and parts replacement to obtain the best possible engine performance.

**Turbocharger** A centrifugal device, driven by exhaust gases, that pressurises the intake air. Normally used to increase the power output from a given engine displacement, but can also be used primarily to reduce exhaust emissions (as on VW's "Umwelt" Diesel engine).

## U

**Universal joint or U-joint** A double-pivoted connection for transmitting power from a driving to a driven shaft through an angle. A U-joint consists of two Y-shaped yokes and a cross-shaped member called the spider.

## V

**Valve** A device through which the flow of liquid, gas, vacuum, or loose material in bulk may be started, stopped, or regulated by a movable part that opens, shuts, or partially obstructs one or more ports or passageways. A valve is also the movable part of such a device.

**Valve clearance** The clearance between the valve tip (the end of the valve stem) and the rocker arm or tappet. The valve clearance is measured when the valve is closed.

**Vernier caliper** A precision measuring instrument that measures inside and outside dimensions. Not quite as accurate as a micrometer, but more convenient.

**Viscosity** The thickness of a liquid or its resistance to flow.

**Volt** A unit for expressing electrical "pressure" in a circuit. One volt that will produce a current of one ampere through a resistance of one ohm.

## W

**Welding** Various processes used to join metal items by heating the areas to be joined to a molten state and fusing them together. For more information refer to the *Haynes Automotive Welding Manual*.

**Wiring diagram** A drawing portraying the components and wires in a vehicle's electrical system, using standardised symbols. For more information refer to the *Haynes Automotive Electrical and Electronic Systems Manual*.

**Note:** References throughout this index are in the form "Chapter number"•"page number"

**A**

Accelerator cable - 4A•5, 4B•3  
 Accelerator pedal - 4A•5, 4B•4, 4B•8  
 Air cleaner - 1•18, 4A•3, 4B•2, 4B•3  
 Air pump - 1•12, 4C•6  
 Air temperature control system - 4B•3, 4B•7  
 Air vents - 3•9  
 Alternator - 5A•6  
 Anti-run-on valve - 4A•20  
 Anti-theft alarm system - 12•17  
 Antifreeze - 0•11, 0•16, 1•2, 1•20, 3•2  
 Asbestos - 0•5  
*Automatic transmission* - 7B•1 *et seq*  
 Automatic transmission - Also see *Transmission*

**B**

Battery - 0•5, 0•13, 5A•3  
 Big-end bearings - 2B•18, 2B•21  
 Bleeding - 6•2, 9•2  
*Body electrical system* - 1•17, 12•1 *et seq*, REF•7  
*Bodywork and fittings* - 1•17, 11•1 *et seq*, REF•9  
 Bonnet - 1•17, 11•8, 12•17  
 Boot - 1•17, 11•9, 12•17  
 Brake fluid - 0•12, 0•16, 1•21  
*Braking system* - 1•8, 1•10, 1•14, 1•15, 1•17, 9•1 *et seq*, REF•6, REF•7, REF•8  
 Bulbs - 0•15, 12•7, 12•9  
 Bumpers - 11•12  
 Burning - 0•5

**C**

Cables - 3•6, 4A•5, 4B•3, 7B•2, 7B•4, 7B•5, 9•9, 11•8, 12•16  
 Calipers - 9•8  
 Camshaft - 2B•13  
 Capacities - 1•2  
 Carburettor - 1•17, 4A•9, 4A•10, 4A•14, 4A•16, 4A•19  
 Carpets - 11•2  
 Cassette player - REF•3  
 Catalytic converter - 4C•4, 4C•7  
 Centre console - 11•11  
 Charcoal canister - 4C•5  
 Choke - 4A•5  
*Clutch* - 1•12, 1•16, 1•17, 6•1 *et seq*  
 Clutch fluid - 0•12, 0•16  
 Coil - 5B•15  
 Compression test - 2A•3  
 Condenser - 5B•9  
 Connecting rods - 2B•15, 2B•21, 2B•22  
 Console - 11•11  
 Constant velocity joint - 8•5  
 Contact breaker points - 1•16, 5B•7, 5B•8

Control box - 1•17, 5A•4  
 Conversion factors - REF•2  
 Coolant - 0•11, 0•16, 1•2, 1•20, 3•2  
 Coolant temperature sensor - 4B•8  
*Cooling, heating and ventilation systems* - 3•1 *et seq*  
 Courtesy light - 12•9  
 Crankcase - 2B•17  
 Crankshaft - 2A•9, 2B•16, 2B•20, 5B•15  
 Crushing - 0•5  
 Cylinder block - 2B•17  
 Cylinder head - 2A•7, 2A•9, 2B•11, 2B•12

**D**

Dents in bodywork - 11•2  
 Depressurisation (fuel system) - 4B•4  
 Dim-dip lighting - 12•11  
 Dimensions - REF•1  
 Discs - 9•8  
 Distributor - 1•16, 1•18, 2A•12, 5B•10, 5B•11  
 Doors - 1•17, 11•4, 11•5, 11•6, 11•7, 11•8, 11•9, 12•6, REF•7  
*Driveshafts* - 1•14, 7A•5, 7B•5, 8•1 *et seq*, REF•8  
 Driving light - 12•8  
 Drums - 9•4  
 Dynamo - 1•17, 5A•4

**E**

Earth fault - 12•4  
 Electric shock - 0•5  
 Electronic control unit (ECU) - 4B•7, 12•17  
*Engine in-car repair procedures* - 2A•1 *et seq*  
 Engine oil - 0•11, 0•16, 1•2, 1•13  
*Engine removal and overhaul procedures* - 2B•1 *et seq*  
 Environmental considerations - REF•17  
*Exhaust and emission control systems* - 1•20, 4C•1 *et seq*, REF•9  
 Exhaust system - 1•10, 4C•1, 4C•3, 4C•4, REF•8

**F**

Facia - 11•10, 11•11, 12•5  
 Fan - 3•5  
 Fan belt - 1•11, 1•12  
*Fault finding* - 4A•10, 4A•14, 5A•3, 12•3, REF•10 *et seq*  
 Filling - 11•2  
 Filter, fuel - 1•21  
 Filter, oil - 1•13, 2A•13  
 Fire - 0•5  
 Fluids - 0•16  
 Flywheel - 2A•10, 6•4  
 Foglight - 12•9  
 Footwell light - 12•9

Fuel filter - 1•21  
 Fuel gauge - 4A•7, 4B•5, 12•15  
 Fuel hoses - 1•16  
 Fuel line - 1•10  
*Fuel system - carburettor engines* - 1•16, 4A•1 *et seq*, REF•9  
*Fuel system - fuel injection engines* - 1•16, 4B•1 *et seq*, REF•9  
 Fuel tank - 4A•7, 4B•5, 4C•6  
 Fume or gas intoxication - 0•5  
 Fuses - 0•15, 12•4

**G**

Gaiters - 1•14, 8•5, 10•17  
 Gashes in bodywork - 11•2  
 Gaskets - REF•17  
 Gear lever - 7A•2, 7A•3, 7B•2, 7B•4, 7B•5  
 Glass - 11•5, 11•10  
*Glossary of technical terms* - REF•18 *et seq*  
 Glovebox - 12•9  
 Grille - 11•12

**H**

Handbrake - 1•9, 9•9, 9•10, REF•6  
 Handles - 11•7  
 HC emissions - REF•9  
 Headlight - 1•12, 12•7, 12•10  
 Heater - 3•6, 3•7  
 Hinges - 11•5  
 Horn - 12•11  
 HT lead - 1•18  
 Hub bearings - 1•9, 1•10, 10•4, 10•10, REF•8  
 Hydrofluoric acid - 0•5  
 Hydrolastic suspension system - 10•3, 10•9, 10•11

**I**

Idle speed adjustment - 1•17, 4A•16, 4A•19  
*Ignition system* - 1•17, 5B•1 *et seq*, 12•6  
 Indicators - 12•9  
 Inhibitor switch - 5B•17, 7B•2, 12•7  
 Injectors - 4B•6  
 Instruments - 1•17, 12•9, 12•14, 12•15  
 Interior light - 12•9

**J**

Jacking - REF•3  
 Joint mating faces - REF•17  
 Jump starting - 0•7

**L**

Lambda sensor - 4C•7  
 Leaks - 0•9, 1•15  
 Locknuts, locktabs and washers - REF•17  
 Locks - 11•6, 11•8, 11•9  
 Lubricants - 0•16

**M**

**Main bearings** - 2B•18  
**Manifold absolute pressure (MAP) sensor** - 4B•7  
**Manifolds** - 4B•9, 4A•20, 4C•4  
**Manual transmission** - 7A•1 *et seq*  
**Manual transmission** - Also see *Transmission*  
**Master cylinder** - 6•3, 9•10, 9•11, 9•13, 9•14, 9•15  
**Mirrors** - REF•6  
**Misfire** - 5B•6  
**Mixture adjustment** - 1•17, 4A•16, 4A•19, REF•9  
**MOT test checks** - REF•6 *et seq*  
**Mountings** - 2A•11, 10•9, 10•13

**N**

**Number plate light** - 12•9

**O**

**Oil cooler** - 2A•14  
**Oil filter** - 1•13, 2A•13  
**Oil pressure relief valve** - 2A•13  
**Oil pump** - 2B•14  
**Oil seals** - 2A•9, 7A•5, REF•17  
**Oil, engine** - 0•11, 0•16, 1•2, 1•13  
**Oil, transmission** - 0•11, 0•16, 1•2, 1•13  
**Open-circuit** - 12•3

**P**

**Pads** - 9•7  
**Paint** - 1•17  
**Pedals** - 4A•5, 4B•4, 4B•8, 6•4, 9•18  
**Pistons and rings** - 2B•15, 2B•19, 2B•21, 2B•22  
**Plastic components** - 11•3  
**Points** - 1•16, 5B•7, 5B•8  
**Poisonous or irritant substances** - 0•5  
**Printed circuit** - 12•16  
**PTC heater** - 4B•9  
**Purge control valve** - 4C•6

**Q**

**Quarterlight glass** - 11•10

**R**

**Radiator** - 3•3  
**Radio** - 12•16, REF•3  
**Radius arm** - 1•10, 10•12

**Re-spraying** - 11•2  
**Relays** - 4C•7, 4B•8, 4B•9, 12•4, 12•5  
**Release bearing** - 6•8  
**Repair procedures** - REF•17  
**Reversing light** - 7B•2, 12•7, 12•9  
**Rocker shaft** - 2A•6  
**Rotor arm** - 1•18  
**Routine maintenance and servicing** - 1•1 *et seq*, 11•1, 11•2  
**Rust holes in bodywork** - 11•2

**S**

**Safety first** - 0•5  
**Scratches in bodywork** - 11•2  
**Screen wash fluid** - 0•13  
**Screw threads and fastenings** - REF•17  
**Seat belts** - 1•12, REF•7  
**Seats** - 1•12, REF•7  
**Selector** - 7B•2, 7B•4, 7B•5, 7A•6  
**Servo unit** - 9•17, 9•18  
**Shock absorbers** - 10•9, 10•12, REF•7, REF•8  
**Shoes** - 9•5  
**Short-circuit** - 12•4  
**Side screen window** - 11•10  
**Sidelight** - 12•9  
**Silencer** - 4C•3  
**Slave cylinder** - 6•2, 6•3  
**Solenoid valve** - 5B•17  
**Spare parts** - REF•3  
**Spark plug** - 1•19  
**Speedometer** - 12•16  
**Springs** - 10•9, 10•11, 10•12, REF•8  
**Starter inhibitor** - 5B•17, 7B•2, 12•7  
**Starter motor** - 5A•7, 5A•8  
**Starting and charging systems** - 5A•1 *et seq*  
**Steering** - See *Suspension and steering*  
**Stepper motor** - 4B•7  
**Stop light** - 12•6, 12•9  
**Subframe** - 10•9, 10•10, 10•13  
**Sunroof** - 11•12  
**Suspension and steering** - 1•9, 1•10, 1•15, 1•17, 10•1 *et seq*, 12•5, REF•6, REF•7, REF•8  
**Switches** - 3•5, 4B•8, 5B•17, 7B•2, 12•5, 12•9, 12•17  
**Swivel hub** - 1•10, 10•3, 10•6

**T**

**Tachometer** - 12•16  
**Tail light** - 12•9  
**Tailgate** - 11•9

**Tappets** - 2B•13, 2B•14  
**Temperature gauge** - 12•15  
**Thermostat** - 3•4  
**Throttle body** - 4B•5  
**Tie-bar** - 10•8  
**Tie-rod** - 10•16  
**Timing** - 1•17, 5B•16  
**Timing chain** - 2A•4  
**Tools** - REF•4, REF•5, REF•17  
**Torque converter** - 2A•10  
**Towing** - 0•9  
**Transfer gears** - 7A•4, 7A•5, 7B•5  
**Transmission** - 2A•11, 2B•4, 2B•5, 2B•6, 2B•7, 2B•9  
**Transmission** - Also see *Manual transmission* and *Automatic transmission*  
**Transmission oil** - 0•11, 0•16, 1•2, 1•13  
**Trim** - 1•17, 11•4, 11•12  
**Tyres** - 0•14, 0•16, REF•9

**U**

**Underframe** - 11•1  
**Unleaded petrol** - 4A•8, 4B•5  
**Upholstery** - 11•2

**V**

**Vacuum servo unit** - 9•17, 9•18  
**Valve clearances** - 1•18, 2A•4  
**Valves** - 2B•12  
**Vehicle identification** - REF•3, REF•7  
**Voltage regulator** - 5A•5  
**Voltage stabiliser** - 12•16

**W**

**Warning lights** - 12•9  
**Washers** - 0•13, 12•13  
**Water pump** - 3•4  
**Weekly checks** - 0•10 *et seq*  
**Weights** - REF•1  
**Wheel alignment** - 10•19  
**Wheel bearings** - 1•9, 1•10, 10•4, 10•10, REF•8  
**Wheel changing** - 0•8  
**Wheel cylinder** - 9•6  
**Wheels** - REF•9  
**Windows** - 11•5, 11•10  
**Windscreen** - 11•9, REF•6  
**Wipers** - 0•15, 12•12, 12•13  
**Wiring diagrams** - 12•7 *et seq*  
**Working facilities** - REF•5



# Preserving Our Motoring Heritage



<  
The Model J Duesenberg Derham Tourster. Only eight of these magnificent cars were ever built – this is the only example to be found outside the United States of America

Almost every car you've ever loved, loathed or desired is gathered under one roof at the Haynes Motor Museum. Over 300 immaculately presented cars and motorbikes represent every aspect of our motoring heritage, from elegant reminders of bygone days, such as the superb Model J Duesenberg to curiosities like the bug-eyed BMW Isetta. There are also many old friends and flames. Perhaps you remember the 1959 Ford Popular that you did your courting in? The magnificent 'Red Collection' is a spectacle of classic sports cars including AC, Alfa Romeo, Austin Healey, Ferrari, Lamborghini, Maserati, MG, Riley, Porsche and Triumph.

## A Perfect Day Out

Each and every vehicle at the Haynes Motor Museum has played its part in the history and culture of Motoring. Today, they make a wonderful spectacle and a great day out for all the family. Bring the kids, bring Mum and Dad, but above all bring your camera to capture those golden memories for ever. You will also find an impressive array of motoring memorabilia, a comfortable 70 seat video cinema and one of the most extensive transport book shops in Britain. The Pit Stop Cafe serves everything from a cup of tea to wholesome, home-made meals or, if you prefer, you can enjoy the large picnic area nestled in the beautiful rural surroundings of Somerset.



>  
John Haynes O.B.E., Founder and Chairman of the museum at the wheel of a Haynes Light 12.



<  
Graham Hill's Lola Cosworth Formula 1 car next to a 1934 Riley Sports.

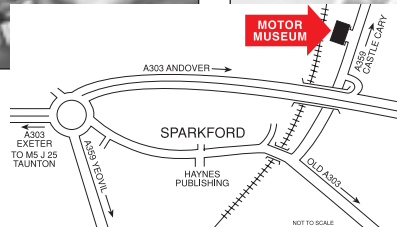

The Museum is situated on the A359 Yeovil to Frome road at Sparkford, just off the A303 in Somerset. It is about 40 miles south of Bristol, and 25 minutes drive from the M5 intersection at Taunton.

Open 9.30am - 5.30pm (10.00am - 4.00pm Winter) 7 days a week, except Christmas Day, Boxing Day and New Years Day  
Special rates available for schools, coach parties and outings Charitable Trust No. 292048