



Owner's Handbook

Instruktieboekje

Manuel du Conducteur

Betriebsanleitung

Manuale di Istruzioni

Manual del Conductor

Manual do Proprietário





MINI

Important Information

The information below replaces that shown in the Cooling System section of the Owner's Handbook, RCL 0179ENG.

Anti-freeze

The anti-freeze content of the coolant must be maintained between 50% and 60% all year round (not just in cold conditions). To ensure that the anti-corrosion properties of the coolant are retained, the anti-freeze content should be checked by your dealer once a year (regardless of mileage).

The coolant should be completely renewed every four years.

Coolant specification

For maximum corrosion prevention, top-up using an ethylene glycol based long-life antifreeze, incorporating silicate based corrosion inhibitors. The anti-freeze must NOT contain methanol or phosphate corrosion inhibitors.

WARNING!

DO NOT use anti-freeze to any specification other than that indicated above.

DO NOT add rust inhibitors or other additives to the coolant - these may not be compatible with the coolant or engine components.

In addition to this handbook, your literature pack contains the following documents:

- **Service Portfolio**

This book includes important information about Rover warranty and vehicle maintenance requirements, as well as containing a unique record of your own car's service history. Ensure that your Rover dealer completes the appropriate service record slip after every service.

- **In-Car Entertainment**

This book contains operating instructions for the audio equipment fitted to your Mini.

- **Security Information Card**

Your Rover dealer should have filled in all the relevant serial numbers concerning your car before delivery. These are important aids to vehicle security; keep the card in a safe place - NOT IN THE CAR.

© Rover Group Limited 1999

Publication Part No. **RCL 0179ENG**

04.99 Mini - 5th Edition

Contents

BEFORE YOU DRIVE

Controls	3	Windows	20
Locks & Alarm	4	Sunroof	21
Seats	10	Heating & Ventilation	23
Seat Belts	12	Interior Equipment	25
Airbag SRS	15	In-Car Entertainment	28
Mirrors	18	Load Carrying	29

DRIVING CONTROLS

Instruments	30	Fuel System	40
Warning Lights	32	Wipers	42
Starting & Driving	34	Lights & Indicators	43
Catalytic Converter	37	Switches	45
Gearbox	39	Brakes	46

MAINTENANCE

Maintenance	48	Washers	56
Bonnet Opening	50	Wipers	58
Engine Compartment	51	Battery	59
Engine	52	Tyres	62
Cooling System	53	Cleaning & Car Care	64
Brakes & Clutch	54		

EMERGENCY INFORMATION

Emergency Towing	69	Bulb Replacement	78
Wheel Changing	71	Parts & Accessories	85
Fuses	74	Vehicle Identification	86

TECHNICAL DATA

Technical Data	87	Index	90
----------------	----	-------	----

Introduction

Welcome to your new Mini. This handbook, together with the other publications in the literature pack, provides all the information you need to gain maximum pleasure from owning and driving your new car.

For your convenience, the handbook is divided into sections, each dealing with a particular aspect of driving or caring for the car. Take a little time to read each one and get to know your new Mini as soon as you possibly can.

- **'Before you drive'** - covers seat adjustment, seat belts and heating controls and deals with everything you need to know to settle comfortably into the car before you drive.
- **'Driving controls'** - describes the functions and operation of the switches, instruments and driving controls.
- **'Maintenance'** - includes information about the checks that you should carry out on a regular basis.
- **'Emergency information'** - will help to solve some of those unavoidable little emergencies that occur from time to time, like replacing bulbs and fuses, or changing a wheel.
- **'Technical data'** - here you will find the technical specification for your car.

WARNING!

Warning boxes and safety information are included in the handbook. These indicate either a procedure which must be followed precisely, or information that should be considered with great care in order to avoid personal injury or damage to the vehicle.

IMPORTANT

The specification of each Rover vehicle will vary according to territorial requirements and also from model to model within the vehicle range. Some of the information published in this handbook, therefore, may not apply to your car. Contact your dealer if you are in any doubt.

Rover operate a policy of constant product improvement and therefore reserve the right to change specifications without notice at any time. Whilst every effort is made to ensure complete accuracy of the information in this handbook, no liabilities for inaccuracies or the consequences thereof, including loss or damage to property, or injury to persons, can be accepted by the manufacturer or the dealer who supplied the handbook, except in respect of personal injury caused by the negligence of the manufacturer or dealer.

Controls

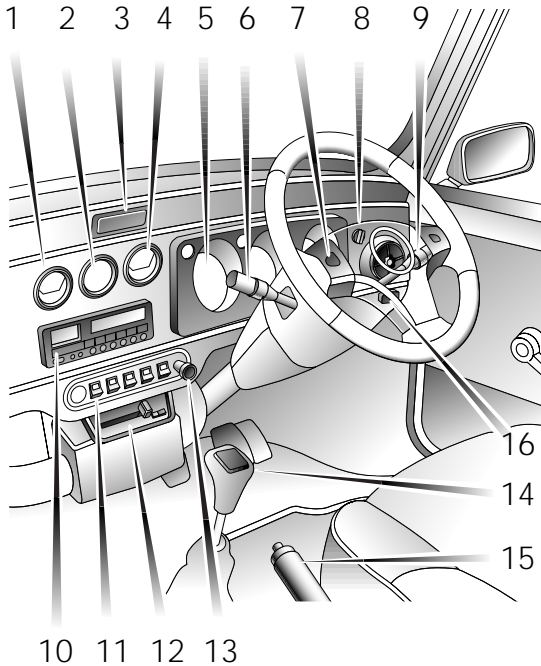

H2108B

1. Voltmeter (if fitted)
2. Clock
3. Ashtray
4. Oil temperature gauge (if fitted)
5. Instrument panel & warning lights
6. Lighting & direction indicator switch
7. Horn
8. Headlight levelling switch
9. Wiper & washer controls
10. Radio/cassette player
11. Auxiliary switches
12. Heater controls
13. Heater temperature control
14. Gear lever
15. Handbrake
16. Bonnet release

Locks & Alarm

ALARM SYSTEM

Your car is fitted with a sophisticated electronic anti-theft alarm and engine immobilisation system. In order to ensure maximum security and minimum inconvenience, you are strongly advised to gain a full understanding of the alarm system, by thoroughly reading this section of the handbook.

ENGINE IMMOBILISATION

Engine immobilisation is an important aspect of the car's security system and includes a feature known as 'passive immobilisation', designed to safeguard the car from theft should the driver forget to lock the doors. The engine is automatically immobilised whenever the alarm is armed, and also thirty seconds after the starter switch is turned off AND the driver's door is opened.

It is almost impossible to leave the car unattended without the engine being immobilised automatically. For this reason, it is important that all drivers are fully aware that the engine can only be re-mobilised by pressing the plain button on the handset. The engine will not be re-mobilised if the car is unlocked with the key.

Care Points

Always adopt this simple 'five-point' drill, whenever you leave your car - even for just a few minutes:

- Fully close all windows, bonnet and sunroof.
- Remove any valuables (or hide them in the luggage compartment).
- Remove the starter key and handset.
- Engage the steering lock (by slightly turning the steering wheel until it locks).
- Lock all the doors and the luggage compartment and arm the alarm.

IMPORTANT INFORMATION

If the starter will not operate:

Press the handset unlock button and try again.

If the starter still does not operate:

Press the handset unlock button at least four times (to resynchronise the handset) and try again.

Locks & Alarm

LOCKING THE CAR

Before locking the car, ensure all doors, windows, sunroof, bonnet and luggage compartment apertures are securely closed.

THE KEY MUST ALWAYS BE USED TO LOCK THE CAR. USING THE HANDSET TO ARM THE ANTI-THEFT ALARM, WILL NOT LOCK THE CAR.

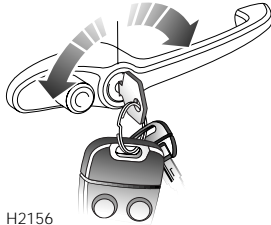

H2156

Door locks

From outside the car, the door locks can only be operated with the appropriate key. Turn the key towards the front to lock and towards the rear to unlock. Press the release button to open the door.

Operating Tip

After locking the car and arming the alarm, there is much you can do to make your car a less inviting target for the thief:

- Try to park where your car can be seen by householders or passers-by.
- At night, always park in well lit areas and try to avoid dimly lit side streets.
- Never leave vehicle documents in the car - these are a real bonus for the thief.
- If you have a garage, use it - and don't risk leaving the key and handset in the starter switch.

Locks & Alarm

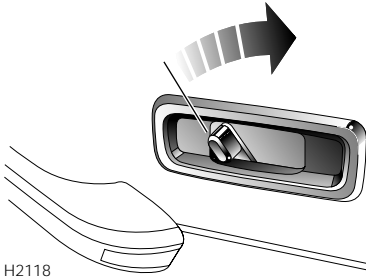

H2118

Interior locking

Both doors can be locked from inside the car by moving the latch rearwards (move the latch forwards to unlock).

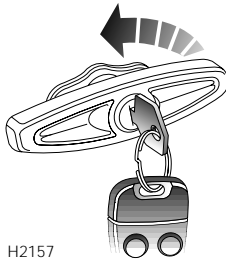

H2157

Luggage compartment lock

Turn the appropriate key anti-clockwise to lock and clockwise to unlock. turn the handle anti-clockwise to open.

IMPORTANT

Using the key to operate the door and luggage compartment locks, will NOT arm or disarm the anti-theft alarm system. Therefore, once armed, the alarm will sound if either door or the luggage compartment are unlocked with the key AND opened - ALWAYS disarm the alarm by pressing the plain handset button, BEFORE unlocking the car.

Locks & Alarm

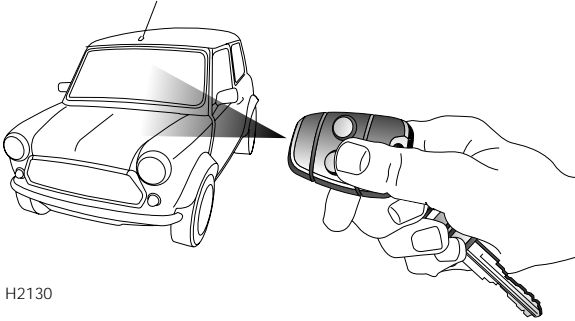

H2130

ARMING THE ALARM

The handset has two buttons which, when pressed, send a coded radio signal to a receiver in the car. The 'padlock' symbol button activates, and the plain button de-activates the following security features:

- The perimetric alarm (protects the door, bonnet, and luggage compartment apertures).
- Electronic engine immobilisation (described previously).

If the alarm sounds

To silence the alarm, press the plain handset button. Once activated the alarm will sound for approximately 30 seconds before switching itself off, and can be triggered up to three times in total before needing to be reset.

Anti-theft alarm indicator light

The RED indicator light on the instrument panel flashes rapidly while the alarm system is arming itself.

After approximately 10 seconds, the indicator light adjusts to a slower frequency, and continues flashing as an anti-theft deterrent until the alarm is next disarmed.

If the alarm is armed when a door or other aperture is still open, the indicator light will not flash for the first 10 seconds but will flash at the slower frequency. The alarm will still be armed, but the open aperture will not be protected. Close the open aperture; the alarm indicator light will flash rapidly and the alarm will automatically arm itself as normal.

Locks & Alarm

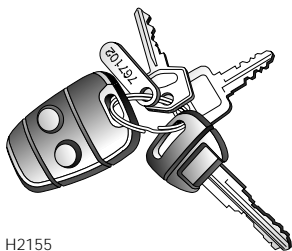

H2155

WARNING!

Keep the Security Information card, key tag, spare handset and keys in a safe place - NOT in the car.

KEY AND HANDSET NUMBERS

You have been supplied with two handsets and two sets of keys, comprising:

- A large plastic handled key for operating the starter switch.
- A small all-metal key which operates the door and luggage compartment locks.
- A larger all-metal key which operates the fuel filler cap lock.

The starter key and handset number is stamped on a tag attached to the key ring. The other key numbers are stamped onto the keys. All key numbers should be entered in the appropriate spaces provided on the Security Information card.

If a key or handset is lost, contact a Rover dealer, who can supply replacement or additional keys and handsets.

Locks & Alarm

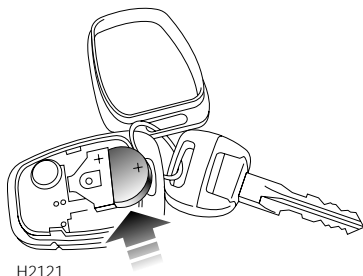

H2121

HANDSET BATTERY

The handset battery should last for approximately three years, dependent upon use. When the battery needs replacing, the operating range of the handset will reduce.

Only fit a Rover YWK 10003 or a Panasonic CR2032 replacement battery (available from a Rover dealer) and adopt the following replacement procedure:

- 1) Carefully prise the handset apart, start from the keyring end using a small coin or screwdriver. Avoid damaging the seal between the two halves of the case and DO NOT allow dirt or moisture to get inside the handset.
- 2) Slide the battery out of its clip, taking care to avoid touching the circuit board or the contact surfaces of the clip.
- 3) Press and hold each button in turn for at least five seconds to drain any residual power from the handset.
- 4) Fit the new battery, ensuring that correct polarity is maintained (positive '+' side facing up). Finger marks will adversely affect battery life; avoid touching the flat surfaces of the battery or wipe them clean before fitting.
- 5) Reassemble the two halves of the handset.
- 6) Unlock the car, then press the handset lock button at least four times to resynchronise the handset to the car.

The handset is now ready for use.

WARNING!

The handset contains delicate electronic circuits and must be protected from impact and water damage, high temperatures and humidity, direct sunlight and the effects of solvents, waxes and abrasive cleaners.

IMPORTANT

Battery disconnection

If the car battery is disconnected for any reason, the status of the security system prior to disconnection, will be memorised and automatically reset when the battery is reconnected.

Seats

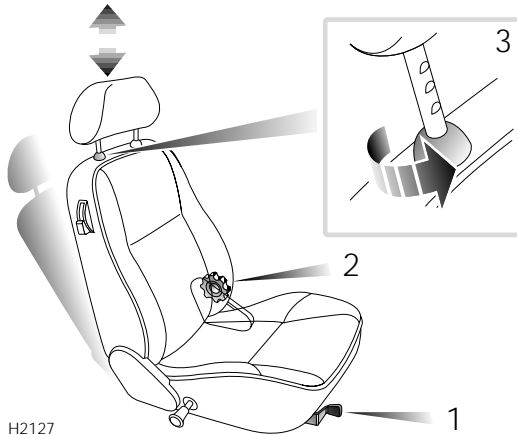

H2127

Forward/backward adjustment

Lift the lever (1) and slide the seat into position. Make sure the seat is locked in position before driving.

Backrest adjustment

Rotate the handwheel (2) to adjust.

Head restraint adjustment

Lift or push down on the restraint, until level with the back of the head.

Head restraint removal

Turn the right hand mounting (3) a quarter turn anti-clockwise and pull the restraint upwards.

WARNING!

DO NOT adjust the seats when the car is moving.
DO NOT allow front seat occupants to travel with the seat backs reclined steeply rearwards.

For Your Safety

Where possible, adjust the head restraint so that the cushion is level with the back of the head - NOT THE NECK!

Seats

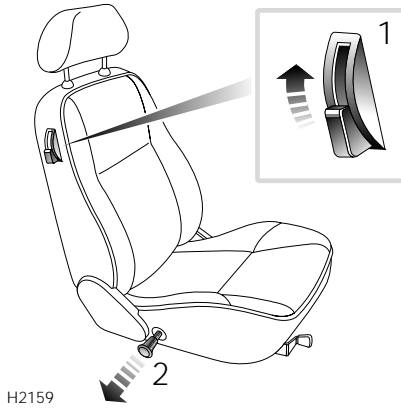

H2159

Rear seat access levers

Lift the lever (1) upwards to fold the backrest forwards.

Pull the lever (2) to fold the whole seat forwards.

For Your Safety
Make sure the backrest is
secure before driving.

Seat Belts

SEAT BELT SAFETY

The seat belts supplied with your car are intended for use by adult sized occupants and must be used by one occupant only.

Ensure that all passengers are securely strapped in at all times and be sure to observe the following precautions:

- Adjust seat belts to eliminate any slack. Do not pull the belt away from the body - to be fully effective, the seat belt must remain in full contact with the body at all times.
- Fit the lap strap across the PELVIS (never across the abdomen), ensuring that the diagonal strap passes across the CHEST and SHOULDER.
- Always replace a seat belt assembly that has withstood the strain of a severe vehicle impact, or if the webbing shows signs of fraying.
- DO NOT wear seat belts over hard, sharp or fragile items in clothing, such as pens, keys, spectacles etc.
- Where possible, use the seat belts to secure luggage carried on the seats - in an accident, loose items can be thrown around inside the car, causing serious injury.
- In most countries, all occupants are required by law to wear a seat belt, unless they have been issued with a medical exemption certificate. During pregnancy, women should wear the lap belt across the hips below the baby, with the diagonal belt passing across the shoulder, between the breasts and to one side of the baby - if in doubt consult a doctor.

For Your Safety

Do not use a seat belt that is twisted or obstructed in any way.

Do not allow occupants to travel with the seat backs reclined steeply rearwards.

Do not allow foreign matter (particularly sugary food and drink particles) to enter the seat belt buckles - such substances can render the buckles inoperative.

Seat Belts

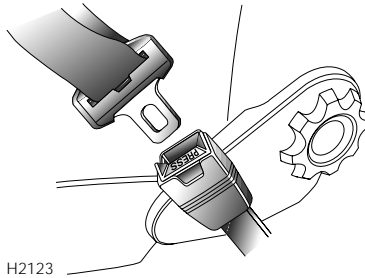

For Your Safety

Where possible, rear seat passengers should adjust their position (moving nearer to or further away from the centre of the car) to enable the seat belt webbing to cross the shoulder without pressing on the neck.

Fastening the belt

Pull the seat belt steadily across the body and, ensuring the webbing is not twisted, insert the metal tongue plate into the appropriate buckle - a 'click' indicates that the belt is securely locked.

Releasing the belt

Press the red button attached to the seat belt buckle.

CHILD SEATS

For safety, it is very important that all infants and young children are restrained in a suitable child safety seat. For further information on child safety seats available for your car, please contact your Rover dealer.

WARNING!

Ensure that all seat belts are worn correctly - an improperly worn seat belt increases the risk of death or serious injury in the event of a collision.

Do not allow a baby or child to be carried on the lap - in an accident, it will be impossible to hold on to the child.

Accident statistics show that children are safer when properly restrained in the rear seating positions than in the front.

Never leave a child unattended in the car.

Seat Belts

Caring for seat belts

Regularly inspect the belt webbing for signs of fraying, cuts and wear, also pay particular attention to the condition of the fixing points and adjusters.

Avoid contaminating the webbing with polish, oil and chemicals (see 'Cleaning & car care').

Three tests for checking seat belts

1. With the seat belt fastened, give the webbing near the buckle a quick upward pull - the buckle should remain securely locked.
2. With the seat belt unfastened, unreel the webbing to the limit of its travel. Check that unreeling is free from snatches and snags.
3. With the webbing half unreeled, hold the tongue plate and give it a quick forward pull - the mechanism must lock automatically and prevent any further unreeling.

If a seat belt should fail any of these tests, contact your dealer immediately.

SEAT BELT PRE-TENSIONERS

The seat belt pre-tensioners act in conjunction with the airbag SRS system and provide additional protection in the event of a severe frontal impact on the vehicle (see 'Airbag SRS'). The pre-tensioners automatically retract the seat belts fitted to the front seats. This reduces any slack in both the lap and diagonal portions of the belts, thereby reducing forward movement of the belt wearer in the event of a severe frontal collision.

The airbag SRS warning light on the instrument panel, described on the following page, will alert you to any malfunction of the seat belt pre-tensioners.

WARNING!

Always replace a seat belt assembly that has withstood the strain of a severe vehicle impact, or one where the webbing shows signs of fraying.

For Your Safety

DO NOT wear seat belts fitted with pre-tensioners directly over bare skin. In the event of a collision, friction burns could occur when the pre-tensioners are activated.

Operating Tip

If the pre-tensioners have been activated, the seat belts will still function as conventional restraints. If it is necessary for the car to be driven to a dealer for repair, the seat belts must be worn.

Airbag SRS

The airbag supplementary restraint system (SRS) provides additional protection for the driver in the event of a SEVERE FRONTAL IMPACT ON THE VEHICLE.

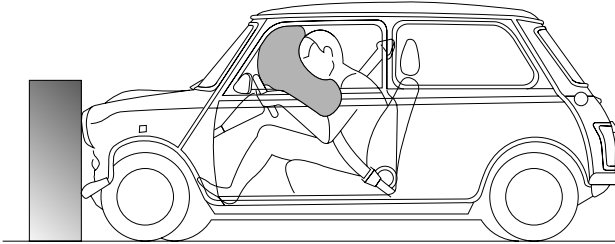

H2141

For Your Safety

Always remember; the airbag SRS provides ADDITIONAL protection in a frontal impact only; it does not replace the need to wear a seat belt. Inflation and deflation of the airbag take place very quickly and it will not protect against the effects of secondary impacts that may occur.

Airbag SRS warning light

The warning light, mounted on the instrument panel, will illuminate for approximately six seconds when the starter switch is turned to position 'II'. The warning light will also alert you to any malfunction of the airbag SRS. The system should be checked by your Rover dealer if any of the following symptoms occur:

- The warning light fails to illuminate when the starter switch is turned to position 'II'.
- The warning light fails to extinguish after approximately six seconds.
- The warning light flashes or illuminates continuously while the car is being driven.

Airbag SRS

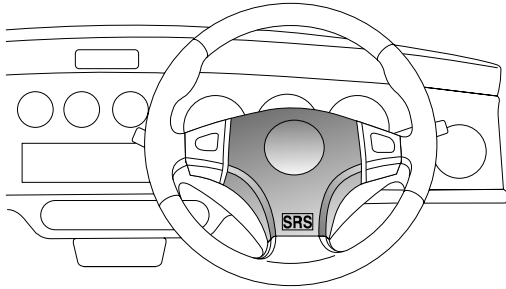

H2148B

How the airbag SRS works

In a frontal collision, a sensor monitors the force of the impact to determine whether the airbag should be inflated. The airbag, contained within the steering wheel centre pad, will inflate in SEVERE frontal collisions only. It will NOT inflate in the event of side or rear impacts, roll over accidents, or minor frontal impacts.

Inflation is instantaneous and accompanied by a loud noise and traces of smoke and powder, none of which are indicative of an airbag malfunction.

After inflation, the airbag module deflates immediately so that the driver's visibility is not impaired.

For Your Safety

After inflation, some airbag components are hot - DO NOT touch until they have cooled.

WARNING!

An inflating airbag can cause facial abrasions and other injuries. Minimise the risk of injury by ensuring the driver is wearing the seat belt and is seated correctly with the seat as far back as is practical.

DO NOT attach accessory items to the airbag module cover (steering wheel centre pad), which could interfere with the inflation of the airbag or, if the airbag inflates, be propelled inside the car causing injury to the occupants.

Airbag SRS

Service information

After 10 years from the date of registration (or installation date of a replacement airbag SRS), some components will need to be replaced by a Rover dealer (*see airbag module replacement date shown on page 2 of the Service Portfolio book*), who should stamp and sign the appropriate page once the work is completed.

In addition, ALWAYS contact your Rover dealer if:

- the airbag inflates.
- the front of the car is damaged (even if the airbag has not inflated).
- any part of the airbag module cover shows signs of cracking or damage.

If you sell your car, be sure to inform the new owner that the car has an airbag SRS, and of the airbag module replacement date shown in the Service Portfolio.

If the car is to be scrapped; uninflated airbags are potentially very dangerous and must be safely deployed in a controlled environment by qualified personnel before a vehicle is scrapped.

WARNING!

DO NOT service, repair, replace, modify or tamper with any part of the airbag SRS or wiring in the vicinity of an airbag SRS component; this could cause the system to activate, resulting in personal injury.

The components of the airbag SRS are sensitive to electrical and physical interference; therefore, ALWAYS seek the assistance of a Rover dealer to carry out any of the following:

Removal or repair of any wiring or component in the vicinity of the airbag SRS components (yellow wiring harness), including the steering wheel, steering column and instrument panel.

Installation of electronic equipment such as a mobile phone, two-way radio or in-car entertainment system.

Attachment of accessories to, or modification of, the front of the car.

Mirrors

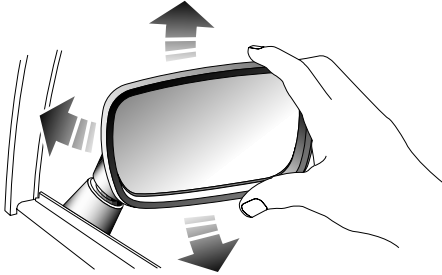

H2143

Exterior mirrors

Adjust the exterior mirrors to give the required view from the driver's seat position.

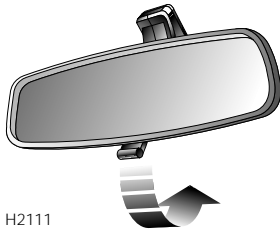

H2111

Interior mirror

Adjust the interior mirror to give the required view from the driver's seat.

The mirror can be dipped to reduce headlight glare from following vehicles;

- Move the lever at the bottom of the mirror towards the windscreen.
- Pull the lever back to restore normal visibility.

For Your Safety

The view reflected in a 'dipped' interior mirror can sometimes confuse the driver as to the precise position of following vehicles. Remember to take additional care!

Mirrors

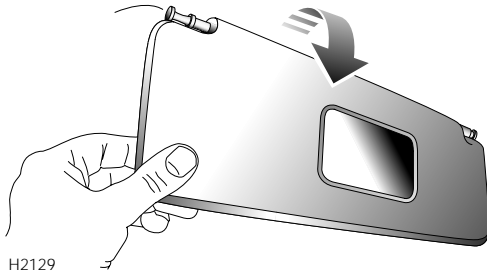

Operating Tip
Always return the sun visor to its stowed position when not in use - the sun, reflected in the vanity mirror, could scorch the seats.

Vanity mirror

To use the vanity mirror, pull down the passenger's sun visor.

Windows

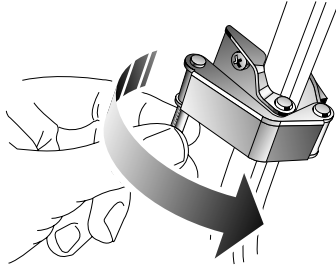

H2158

For Your Safety
Ensure that children are kept clear while operating the windows.

Front windows

Turn the handle to open or close window as required.

Rear ventilator windows (illustrated)

To open, pull the catch forwards, then push outwards (as arrowed).

To close, pull the centre of the catch inwards, then push rearwards until the catch is felt to 'snap' into the locked position.

Sunroof

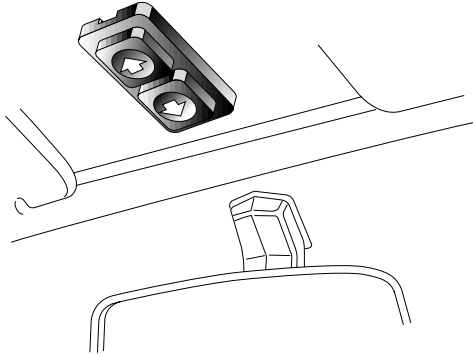

H2164

SUNROOF (if fitted)

The sunroof can be operated when the starter switch is turned to position 'I' or 'II'.

Opening and closing

To open the roof, press and hold the rear switch.

To close the roof, press and hold the front switch.

Always release the switch as soon as the sunroof has stopped moving.

Operating Tip

If you want to drive with the sunroof partially open: Open the sunroof fully and then close it to the desired position - this will keep wind noise to a minimum.

Don't operate the sunroof when it is obstructed, or covered in ice or snow - damage could be caused.

Always close the roof when the car is left unattended.

WARNING!

Keep passengers clear while operating the sunroof - closing the roof on any part of the body, could result in serious injury.

DO NOT leave children alone in the car.

DO NOT allow passengers to extend any part of their bodies through the sunroof aperture when the car is moving - injury from flying debris, branches of trees or other obstructions could occur.

Sunroof

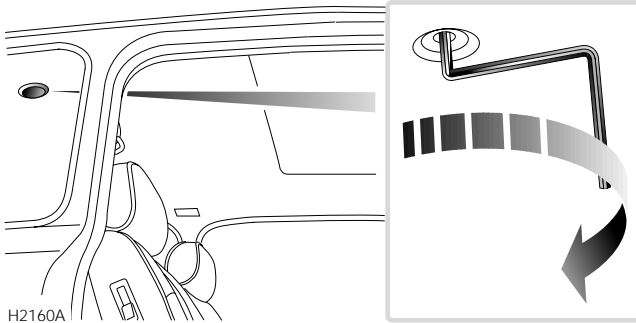

Emergency operation

If the electric motor will not close the sunroof, it can be closed manually by following the procedure below.

1. Remove the circular access plug situated in the roof lining to the rear of the sunroof.
2. Insert the cranked key into the drive spindle and turn it clockwise to close the roof.

See your Rover dealer and have the fault rectified as soon as possible.

Heating & Ventilation

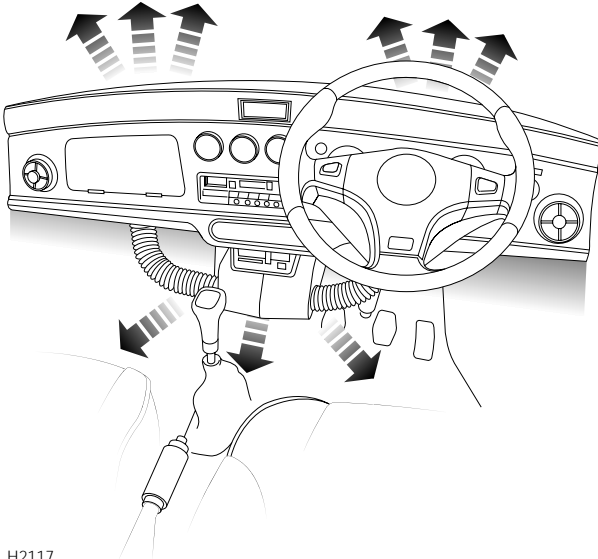

H2117

The heating and ventilation system provides fresh or heated air to the interior of the car. Air outlets are provided to the windscreen, face and feet - the location of the vents is shown in the illustration above.

The heater requires heat from the engine in order to supply heated air to the interior of the car. For this reason, full heating is not available unless the engine is running and has reached its normal operating temperature.

Remember, with the blower switched off, the amount of air entering the car is dependent on driving speed alone.



H2116

Face level vents

The face level vents supply fresh air only, and are not affected by the heater controls - the volume of air entering the car is dependent on driving speed alone.

Rotate the knob in the centre clockwise or anti-clockwise to open or close the vents. Move the vent to direct air as required.

Heating & Ventilation

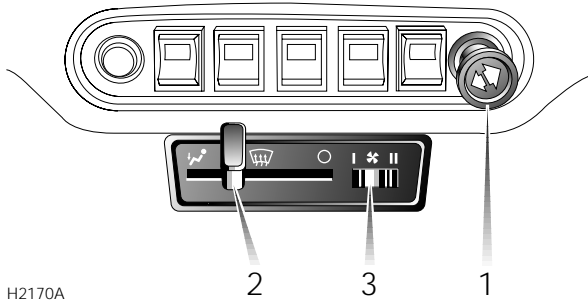

H2170A

1. Air temperature control

HEATED AIR: Pull the control out.

UNHEATED AIR: Push the control in.

2. Air distribution control

Left position: Foot level vents (with reduced air supply from windscreen vents).

Centre position: Windscreen vents.

Right position: Foot level and windscreen vents closed (fresh air from face level vents only).

3. Blower switch

To operate the blower, the starter switch must be turned to position 'I' or 'II'.

Position 'I': Low blower speed.

Position 'II': High blower speed.

Centre position: Blower off.

Fresh air enters the car through a grille at the front of the car, which should always be kept clear of obstructions, including leaves, snow and ice.

Operating Tip

Maximum demisting/defrosting

Select the centre position on the air distribution control, pull the air temperature control fully out and set the blower switch to 'II'.

Maximum heating

Select the left position on the air distribution control, pull the air temperature control fully out and set the blower switch to 'II'.

Maximum ventilation

Select the left position on the air distribution control, push the air temperature control fully in and set the blower switch to 'II'. Open and direct the face level vents as required.

Operating Tip

When foot and windscreen vents are closed (air distribution control to the right), keep the blower switch off.

Interior Equipment

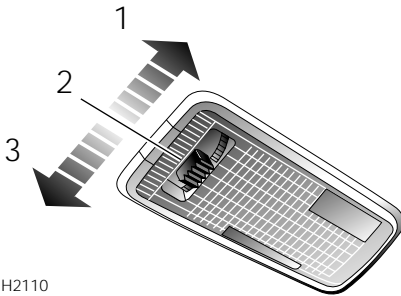

H2110

INTERIOR LIGHT

Switch positions:

1. Light permanently on.
2. Light permanently off.
3. Light comes on automatically when a door is opened.

Interior Equipment

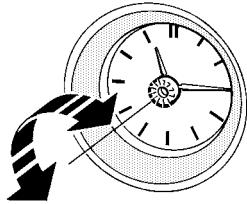

3PR 0030

Care Points

If the car battery is disconnected, the clock will need to be reset.

CLOCK

The clock face is illuminated automatically when the sidelights are switched on and the starter switch is turned to position 'I' or 'II'.

Adjusting the hands

Press and turn the central adjuster to set the hour and minute hands.

Interior Equipment

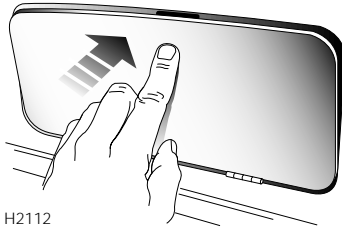

For Your Safety
DON'T drive with the glovebox open. An open glovebox could cause injury to a front seat passenger in the event of a collision.

GLOVEBOX

Press the upper edge of the glovebox lid to open.

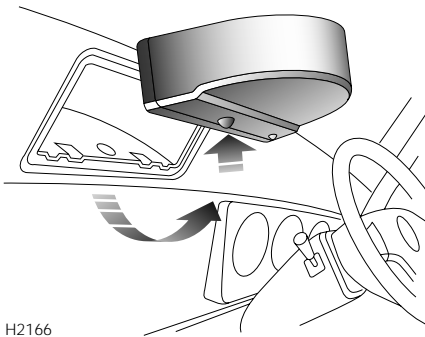

WARNING!

*Ashtrays are fire hazards -
DON'T use for waste paper
or other combustible
material.*

ASHTRAY

Push the front of the ashtray on the right hand side to open.

To remove for emptying, open the ashtray, then carefully lever the front of the tray upwards to disengage the lower pivot (arrowed in illustration). The ashtray can then be pulled out.

Replacement is a reversal of this process.

In-Car Entertainment

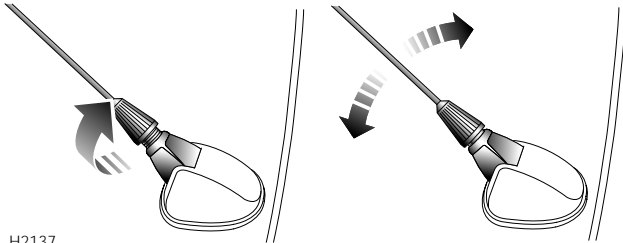

H2137

Care Points

ALWAYS unscrew and remove the aerial before entering an automatic car wash.

RADIO AERIAL

Your car is equipped with a detachable mast aerial mounted on the roof; unscrew to remove.

Always check the available headroom and, if necessary, adjust the angle of the aerial before entering or leaving a garage or car park with insufficient headroom.

RADIO/CASSETTE PLAYER

Full operating instructions for the audio equipment fitted as standard to your car, are contained in the '*In-car Entertainment*' book in the vehicle literature pack.

Load Carrying

Rear window shelf

Hard, heavy or pointed objects should not be carried on the rear window shelf - they may cause personal injury or damage the rear window itself during a sudden manoeuvre.

Roof racks

Make sure that you only fit a roof rack that is approved for your car. Your Rover dealer can provide details of all Rover approved roof racks.

The total roof rack load (including the weight of the roof rack), must never exceed the figure given under '*Weights*' in the '*Technical data*' section of this handbook. Owners should be aware that, if the roof rack is to be loaded to its maximum, then the carrying capacity of the car interior must be limited to a maximum of three adult passengers only, with no luggage in the rear of the car or the boot.

When loading the roof rack, make sure that all loads are evenly distributed and properly secured within the periphery of the rack.

Towing

Your Mini is not suitable for towing.

For Your Safety

Do not carry unsecured equipment, tools or luggage inside the car, that could move, causing personal injury in the event of an accident or emergency manoeuvre. Secure larger objects with a seat belt.

A loaded roof rack can reduce the stability of your car, particularly when cornering and encountering crosswinds.

Instruments

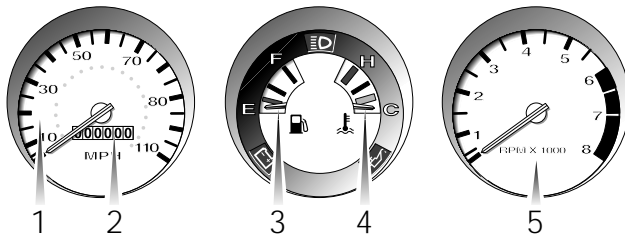

H2151

1. Speedometer

Indicates road speed in miles per hour and/or kilometres per hour.

2. Total distance recorder (odometer)

Indicates the total distance travelled by the car.

3. Fuel gauge

The pointer indicates the quantity of fuel in the tank once the starter switch is turned on.

4. Coolant temperature gauge

The gauge indicates the temperature of the engine coolant. As the engine warms up, the pointer will rise from the BLUE ('C' - cold) mark to the mid-point of the gauge, where it should remain while the engine is operating at its normal temperature.

If the pointer reaches the RED ('H' - hot) mark, the coolant is too hot and severe engine damage could result; stop the car as soon as safety permits and seek qualified assistance.

5. Tachometer

Indicates engine speed in revolutions per minute (x 1000). To protect the engine from damage, NEVER allow the engine speed to exceed 6,000 revolutions per minute.

Operating Tip

Driving on twisting or hilly roads may adversely affect the accuracy of the fuel gauge. It is advisable to check the fuel level when the car is travelling on a straight level road.

WARNING!

Never allow the car to run out of fuel (the resultant misfire could damage the catalytic converter).

Instruments

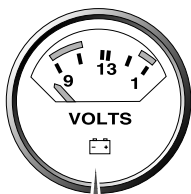

H2150

6



7

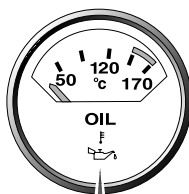

6. Voltmeter (if fitted)

Indicates battery voltage. During normal driving, the pointer should register between 12 and 15 volts depending on road speed and electrical loads.

If the pointer falls into the lower RED zone while driving, the battery is receiving insufficient charge. Switch off unnecessary electrical equipment, and if the pointer remains in the RED zone seek qualified assistance.

If the pointer enters the upper RED zone, this indicates a serious fault with the charging system; seek qualified assistance urgently.

7. Oil temperature gauge (if fitted)

Indicates the temperature of the engine oil. For gentle and moderate speed driving, expect the pointer to rest between 90° C and 120° C (2nd and 3rd graduations on the gauge). Sustained high speed motoring may cause the temperature to rise to 150° C (4th graduation on the gauge - on the edge of the RED zone). If the pointer enters the RED zone, you must reduce road speed immediately and drive GENTLY until the temperature falls below 150° C. If the oil temperature does not fall, stop the car as soon as safety permits and seek qualified assistance.

Warning Lights

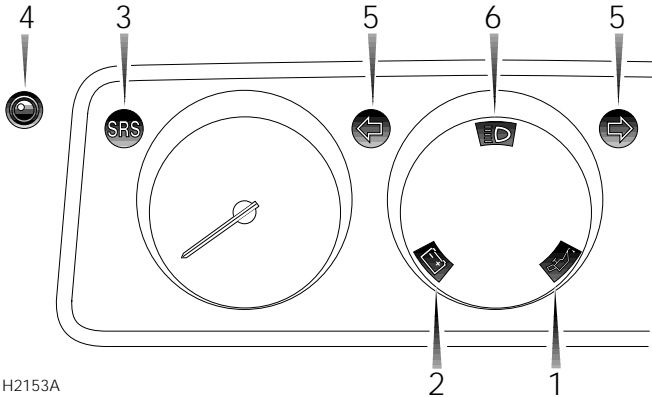

H2153A

1. Low oil pressure - RED

Illuminates as a bulb check when the starter switch is turned to position 'II' and extinguishes when the engine is started. If the light remains on, or illuminates whilst driving, stop the car as soon as safety permits and switch off the engine immediately. Seek qualified assistance before driving.

2. Battery charging - RED

Illuminates as a bulb check when the starter switch is turned to position 'II' and extinguishes when the engine is started. If the light remains on, or illuminates whilst driving, a fault with the battery charging system is indicated. Seek qualified assistance urgently.

3. Airbag supplementary restraint system - RED

The light illuminates when the starter switch is turned to position 'II' and extinguishes within approximately six seconds. If the light fails to illuminate, or illuminates again after the six second period, the system is faulty - seek qualified assistance urgently.

4. Anti-theft alarm indicator - RED

Illuminates in conjunction with the anti-theft alarm system (see '*Anti-theft alarm*').

Warning Lights

5. Direction indicators - GREEN

The left or right warning light flashes in time with the left or right direction indicator lights, whenever they are operated. If either warning light fails to illuminate, or flashes very rapidly, this means that one of the indicator lights is not operating.

6. Headlight main beam - BLUE

Illuminates when the headlights are switched to main beam.

Operating Tip

When the hazard warning lights are operated, both direction indicator warning lights will flash together.

Starting & Driving

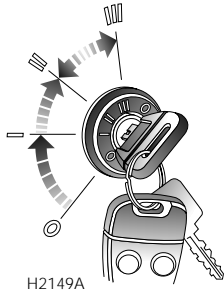

STARTER SWITCH & STEERING LOCK

The starter switch uses the following sequence of key positions to operate the steering lock, electrical circuits and starter motor.

'0' - Steering locked

With the key removed, the steering column will be locked and the lighting circuits operational.

'1' - Steering unlocked

Turn to position '1' to unlock the steering. The radio/cassette player can now be operated.

'II' - Electrical circuits on

With the switch in position 'II', all instruments and electrical systems are operational.

'III' - Starter motor operates

Turn to position 'III' to operate the starter motor; release the key as soon as the engine starts (the key will automatically return to position 'II').

WARNING!

Once the steering lock is engaged, it is impossible to steer the car.

DO NOT remove the key, or turn the starter switch to position '0', while the car is in motion.

Operating Tip

Unlocking the steering

After inserting the key, a small movement of the steering wheel will help to disengage the lock before turning the switch to position '1'.

Locking the steering

After removing the starter key, turn the steering wheel slightly - you will hear the lock 'click' into engagement.

Starting & Driving

Starting the engine

1. Check that the handbrake is on and the gear lever is in neutral.
2. Switch off all unnecessary electrical equipment.
3. Turn the starter switch to position 'III' and release the key as soon as the engine has started.

Do not press the accelerator pedal while starting and do not operate the starter for more than 10 seconds at a time. Wait for at least 10 seconds before trying to start the engine again.

Cold climates

In cold climates, engine cranking times may increase - reduce the load on the battery by depressing the clutch while operating the starter motor.

Warming up

In the interests of fuel economy, drive the car soon after starting; remember that harsh acceleration or labouring the engine before normal operating temperatures have been reached, can damage the engine.

Switching off the engine

After stopping the car, always apply the handbrake and select neutral before releasing the foot brake and switching off the engine.

Depending on the engine temperature, the cooling fan may commence operating after the engine is switched off, and continue operating for several minutes. This is normal, and not a cause for concern.

WARNING!

Never start, or leave the engine running, in an unventilated building - exhaust gases are poisonous and contain carbon monoxide, which can cause unconsciousness and may even be fatal.

Care Points

Catalytic converters can be damaged if the wrong fuel is used, or if an engine misfire occurs. Before starting the engine, you should be aware of the precautions detailed under 'Catalytic converter'.

Continued use of the starter will not only discharge the battery, but may damage the starter motor and the catalytic converter.

Operating Tip

In freezing conditions, or when the battery is in a low state of charge, depress the clutch while operating the starter; this will reduce the load on the battery.

Starting & Driving

RUNNING-IN

The engine, gearbox, brakes and tyres need time to 'bed-in' and adjust to the demands of everyday motoring. During the first 600 miles (1,000 km) it is essential that you drive with consideration for the running-in process and heed the following advice:

- Do not allow the engine to exceed 3,000 rev/min in any gear.
- Do not exceed 60 mph (95 km/h).
- Do not operate at full throttle in any gear.
- Do not allow the engine to labour in any gear.
- Avoid heavy braking.

After the running-in distance has been completed, engine speeds may be gradually increased.

FUEL ECONOMY

Fuel consumption is influenced by two major factors:

- How your car is maintained.
- How you drive.

To obtain optimum fuel economy, it is essential that your car is maintained in accordance with the manufacturer's recommendations, but above all, the way in which you drive is most important. Note the operating tips alongside.

Operating Tip

The following hints may help you to obtain optimum fuel consumption:

- Avoid unnecessary short, start-stop, journeys.
- Avoid fast starts. Always accelerate smoothly and gently from rest.
- Do not drive in low gears for longer than necessary.
- Decelerate gently and avoid sudden and heavy braking.
- Anticipate obstructions well in advance, and adjust your speed accordingly,

Catalytic Converter

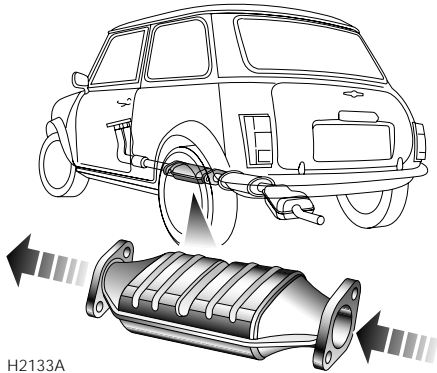

H2133A

WARNING!

Exhaust temperatures can be extremely high, do not park on ground where combustible materials such as dry grass or leaves could come in contact with the exhaust system - in dry weather a fire could result.

The exhaust system on your car incorporates a catalytic converter which converts poisonous exhaust emissions into environmentally less harmful gases, thereby reducing pollution.

Catalytic converters are easily damaged through improper use, so be sure to take notice of the following precautions to minimise the chance of accidental damage.

Fuel

- Only use 95 RON UNLEADED petrol to EN 228 specification. Using leaded fuel will destroy the catalyst.
- Never allow the car to run out of fuel - this could cause a misfire which could damage the catalyst.

Starting

- Do not continue to operate the starter after a few failed attempts, seek qualified assistance.
- Do not operate the starter if an engine misfire is suspected and do not attempt to clear a misfire by pressing the accelerator pedal.
- Do not attempt to push or tow start the car.

Catalytic Converter

Driving

- Do not overload or excessively 'rev' the engine.
- Do not switch off the engine when the car is in motion with a drive gear selected.
- Consult your dealer if you think your car is burning too much oil, as this will progressively reduce catalyst efficiency.
- If a misfire is suspected, or the car lacks power while driving, provided the engine has reached its normal operating temperature, it may be driven SLOWLY (at risk of catalyst damage) to a Rover dealer for assistance.
- DO NOT run the engine with a spark plug or lead removed, or use any device that requires an insert into a spark plug.
- Do not drive the car on terrain likely to subject the underside of the car to heavy impacts.

IMPORTANT

Any engine misfire, loss of engine performance or engine run-on, could seriously damage the catalytic converter. For this reason, it is vital that unqualified persons do not tamper with the engine, and that regular maintenance is carried out by a Rover dealer in accordance with the service interval plan in the Service Portfolio book.

Gearbox



H2146

Care Points

Do not rest your hand on the gear lever when driving - pressure from your hand may cause premature wear to the gear selector mechanism.

Do not rest your foot on the clutch pedal when driving - excessive wear to the clutch will result.

Do not hold the car stationary on a hill by slipping the clutch. This will wear out the clutch. Always use the handbrake.

The gear positions are indicated on the gear lever knob.
Synchronmesh engagement is provided on all forward gears.

Selecting reverse

Before selecting reverse gear, ensure the car is stationary!

1. Fully depress the clutch pedal.
2. From the neutral position move the gear lever to the right.
3. While lifting the lever, ease it to the right before pulling it fully rearwards.

Fuel System

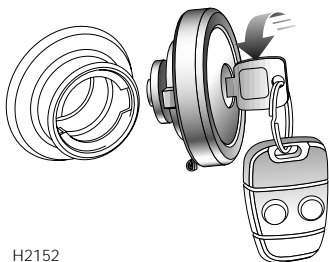

H2152

FUEL FILLING

The fuel filler is located in the rear left hand wing. Insert the larger all-metal key in the lock, turn it anti-clockwise and allow any pressure inside the tank to escape, before removing the cap. Remember to lock the cap after refuelling.

The filler tube is designed to accept a narrow filler nozzle of the type found on pumps that deliver only unleaded fuel. A flap lies across the filler neck; insert the nozzle sufficiently to fully open the flap before filling.

Fill the tank slowly until the filler nozzle automatically cuts-off the fuel supply. DO NOT attempt to fill the tank beyond this point, or spillage could result due to expansion of the fuel.

Grade of fuel

The RON (octane rating) of petroleum commonly available at garage forecourts, will vary in different countries. The 95 RON unleaded specification, is a minimum requirement and can be safely exceeded. However, lower octane fuels may cause serious damage to the engine.

Empty fuel tank

NEVER allow the car to run out of fuel - the resultant misfire may destroy the catalytic converter. In the event of the fuel tank running dry, contact your Rover dealer before attempting to start the engine.

For Your Safety

Petroleum gases are highly inflammable and, in confined spaces, are also extremely explosive. Always take care when refuelling:

- Switch off the engine.
- Do not smoke or use a naked flame.
- Avoid spilling fuel.
- Do not overfill the tank.

Fuel specification:

95 RON unleaded petrol to EN 228 specification

WARNING!

USE ONLY UNLEADED PETROL. Serious damage to the catalytic converter will occur, if leaded fuel is used.

DO NOT fully fill the tank if the car is to be parked on a slope in direct sunlight, or high ambient temperature - expansion of the fuel could cause spillage.

Fuel System

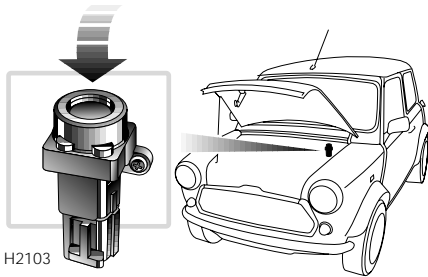

WARNING!

ALWAYS check for fuel leaks before resetting the fuel cut-off switch.

FUEL CUT-OFF SWITCH

The fuel cut-off switch is a safety device which, in the event of a collision or sudden impact, automatically cuts off the fuel supply.

The switch is located on the left hand side of the engine compartment, mounted on the bulkhead. After the switch has been activated, it must be reset by pressing the rubber top before the engine can be restarted.

Wipers

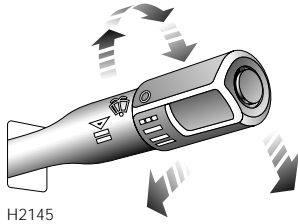

WIPER CONTROLS

The wipers and washers will only operate when the starter switch is turned to position 'I' or 'II'.

Single wipe

Pull the lever down and release.

NOTE: *With the lever held down, the wipers will operate at high speed until it is released.*

Intermittent wipe

Turn switch to first position.

Normal speed wipe

Turn switch to second position.

Fast speed wipe

Turn switch to third position.

Windscreen washer

Pull the lever towards the steering wheel. The washers will operate for as long as the lever is held in this position.

NOTE: *The wipers operate automatically during windscreen washing.*

Care Points

DO NOT operate the wipers on a dry screen.

DO NOT operate the wipers with the bonnet raised.

In freezing or very hot conditions, ensure that the blades are not frozen or stuck to the glass before being operated.

In winter, remove snow or ice from around the arms and blades, including the wiped area of the windscreen.

Lights & Indicators

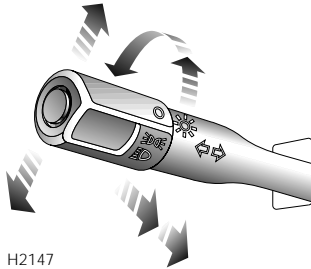

Direction indicators

The direction indicators will only operate with the starter switch turned to position 'II'.

- For a right-hand turn, push the lever up.
- For a left-hand turn, push the lever down.

The appropriate warning light on the instrument panel will flash GREEN while the direction indicators are operating. The indicators will cancel automatically once a turn has been completed.

Side, tail and instrument panel lights

Turn the switch to the first position.

Headlights

Turn the switch to the second position.

Headlight - main, dipped beam and flash

Pull the lever fully towards the steering wheel to change headlight beams (the BLUE warning light on the instrument panel illuminates when the headlights are on main beam).

Pull the lever half-way towards the steering wheel to briefly flash the headlights.

Driving lamps (if fitted)

The driving lamps will illuminate automatically when the headlights main beams are switched on.

Operating Tip

Hold the direction indicator lever half-way up or down to indicate a lane change.

The side, tail and headlights operate with the starter switch in any position.

Lights & Indicators

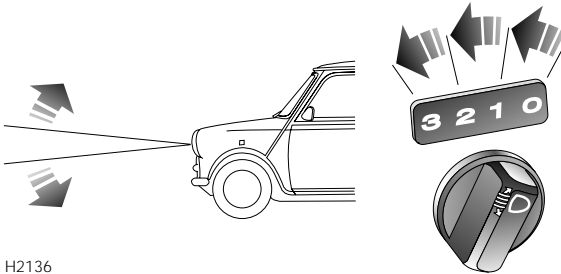

H2136

For Your Safety

The loading definitions alongside assume that all loads will be within the limits of the maximum permissible axle and vehicle weights.

Headlight levelling

The height of the headlight beams is affected by the distribution of weight inside the vehicle. Always ensure your headlights are adjusted so that the point at which they meet the road surface ahead of the car, provides adequate illumination, without dazzling other road users.

Adjust the headlights using the following guide:

- '0' - Driver alone or both front seats occupied (luggage compartment empty).
- '1' - All seats occupied (no luggage).
- '2' - All seats occupied PLUS luggage.
- '3' - Driver alone PLUS full luggage compartment.

Switches

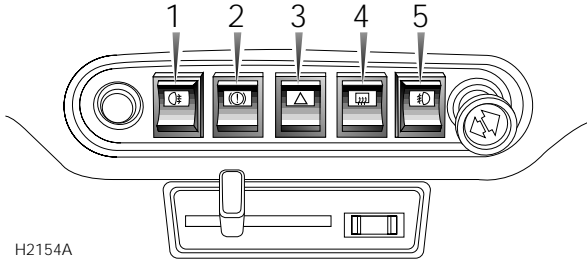

H2154A

FASCIA SWITCHES

1. Rear fog guard light

Press the bottom of the switch to operate; the indicator light in the switch illuminates when the rear fog guard light is on. The rear fog guard light operates **ONLY** with the starter switch at position 'II' and the headlights switched on.

2. Brake fluid level warning light

With the starter switch in position 'II', press the bottom of the switch to test the warning light bulb (RED). If the warning light illuminates at any other time, the brake fluid level is too low and should be topped up as soon as possible (see 'Brakes' in the Maintenance section).

Test the bulb and check the brake fluid level regularly.

3. Hazard warning lights

Press the bottom of the switch to operate. All the direction indicators will flash together. Use **ONLY** in an emergency to warn other road users when your vehicle is causing an obstruction or is in a hazardous situation. Remember to switch off before driving away.

4. Rear screen demister

Press the bottom of the switch to operate; the indicator light in the switch illuminates whenever the demister is on. Switch the demister off as soon as the rear screen is clear.

5. Front fog lights (if fitted)

Press the bottom of the switch to operate; the indicator light in the switch illuminates when the fog lights are on. The fog lights operate **ONLY** with the side or headlights switched on.

Operating Tip

The front and rear fog lights extinguish automatically when the main lighting switch is turned off. However, they will illuminate again automatically when the lights are next switched on unless switched off manually.

Care Points

The heating elements on the inside of the rear screen are easily damaged. **DO NOT** scrape or scratch the glass. **DO NOT** stick labels over the rear screen demister elements, and take note of advice given in 'Cleaning & car care'.

WARNING!

*The front or rear fog lights can **ONLY** legally be used when visibility is severely restricted - other road users could be dazzled in clear conditions!*

Brakes

BRAKING SYSTEM

The hydraulic braking system operates through dual circuits; if one circuit should fail, the other will continue to function. However, in the event of a brake failure where only one circuit is operational, the car should only be driven slowly to the nearest Rover dealer - exercise EXTREME CAUTION and be aware that much greater pedal effort and longer stopping distances will be required if one circuit has failed.

The braking system is servo assisted. This means that if the engine stops running, servo assistance will be lost, resulting in greater pedal effort and longer stopping distances.

Brake pads

Brake pads and linings require a period of bedding in. During the running-in period (see '*Starting & Driving*'), avoid situations where heavy braking is required.

Remember, regular servicing is vital to ensure that brake components are examined for wear at the correct intervals and changed whenever necessary to ensure optimum safety and performance.

Brake fluid warning light

If the warning light (in the switch) illuminates while driving, the brake fluid level is too low; stop the car as soon as safety permits and top up the brake fluid reservoir (refer to the 'Maintenance' section).

You should regularly test the brake fluid warning light by pressing the bottom of the switch. If the switch is operating correctly, the light in the switch will illuminate.

WARNING!

DO NOT rest your foot on the brake pedal while driving; this may overheat the brakes, reducing their efficiency and causing excessive wear.

If the brake warning light illuminates while driving, stop the car as soon as safety permits and seek qualified assistance before continuing.

NEVER move the car without the engine running, servo assistance may not be available. Without servo assistance, the brakes will still function, but greater pedal pressure and longer stopping distances will be required.

Brakes

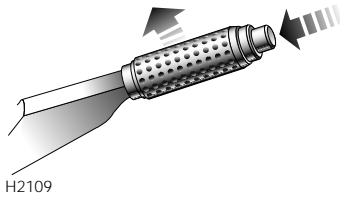

H2109

HANDBRAKE

The handbrake operates on the rear wheels only and should not require adjustment. To apply the handbrake, pull the lever up. Always apply the handbrake fully whenever you park the car.

To release, pull the lever up slightly, depress the button (arrowed in illustration) and fully lower the lever.

WARNING!

DO NOT drive with the handbrake applied, this could damage the rear brakes and axles.

Operating Tip

While applying the handbrake, hold the button in to minimise wear on the ratchet.

Maintenance

ROUTINE SERVICING

The safety, reliability and performance of your car will depend partly on how it is maintained.

Maintenance is the owner's responsibility; make sure that all routine services and warranty inspections are carried out by a Rover dealer at the recommended intervals shown in the Service Portfolio book. You will find this book in the literature pack.

The Service Portfolio book also includes a Service Record section, which enables a record to be kept of all the routine services carried out on the car - ensure your dealer endorses the book after each service.

OWNER MAINTENANCE

In addition to the routine services and warranty inspections referred to above, a number of simple checks must be carried out more frequently. These are listed alongside. You can do these yourself and advice is given on the following pages.

Daily Checks

- Operation of lights, horn, direction indicators, wipers, washers and warning lights.
- Operation of seat belts and brakes.
- Look for fluid deposits beneath the car that may indicate a leak.

Weekly Checks

- Engine oil level.
- Coolant level.
- Brake fluid level.
- Clutch fluid level.
- Screen washer fluid.
- Tyre pressures and condition.

Maintenance

SAFETY IN THE GARAGE

If you need to carry out maintenance, observe the following safety precautions at all times:

- Keep your hands, tools and clothing away from drive belts and pulleys.
- If the car has been driven, DO NOT TOUCH exhaust and cooling system components until the engine has cooled.
- DO NOT TOUCH electrical leads or components while the engine is running, or with the starter switch turned on.
- NEVER leave the engine running in an unventilated area - exhaust gases are poisonous and extremely dangerous.
- DO NOT work beneath the car with the wheel changing jack as the only means of support.
- Ensure sparks and naked lights are kept away from the engine and luggage compartments.
- Remove wrist bands and jewellery before working in the engine compartment.
- DO NOT allow battery leads or terminals to make contact with tools or metal parts of the car.

Poisonous fluids

Fluids used in motor vehicles are poisonous and should not be consumed or brought into contact with open wounds. These include: battery acid, anti-freeze, brake and clutch fluid, petrol, engine oil and windscreen washer additives. Obey all instructions printed on labels and containers.

WARNING!

Cooling fans may operate after the engine is switched off. Keep clear of all fans while working in the engine compartment.

Care Points

Prolonged contact with engine oil may cause serious skin disorders, including dermatitis and cancer of the skin. Wash thoroughly after contact.

It is illegal to pollute drains, water courses or soil. Use authorised waste disposal sites to dispose of used oil and toxic chemicals.

Bonnet Opening

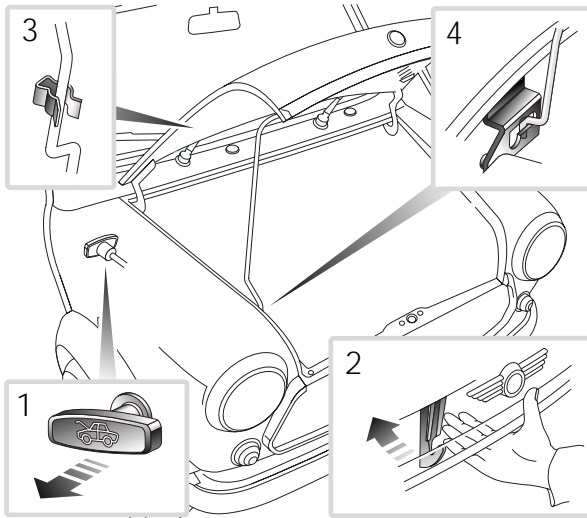

H2162

1. From inside the car, pull the bonnet release lever.
2. Push the safety catch lever away from the front of the bonnet and raise the bonnet.
3. Unclip the support stay.
4. Fit the support stay into the bracket as shown.

Closing the bonnet

Raise the bonnet slightly to release the support stay, then replace the stay in the clip. Lower the bonnet onto the catch, then use the palms of both hands to press the bonnet fully down to engage the catch.

WARNING!

DO NOT drive with the bonnet retained by the safety catch alone.

For Your Safety

After closing the bonnet, check that the lock is fully engaged by attempting to lift the front edge of the bonnet. This should be free from all movement.

Engine Compartment

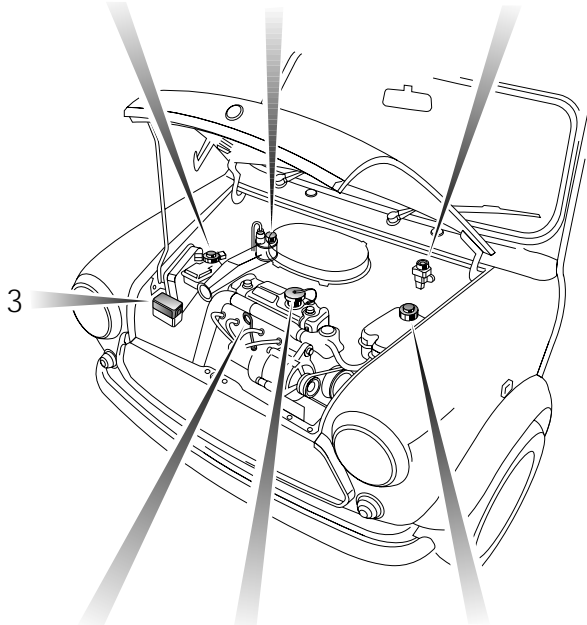
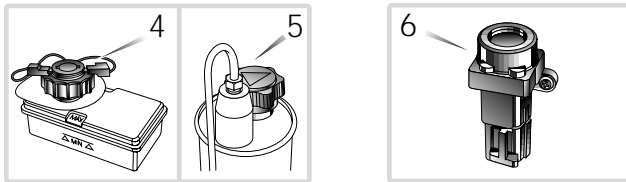

WARNING!
While working in the engine compartment, always observe the safety precautions listed under 'Safety in the garage' on a previous page.

1. Engine oil filler
2. Engine oil dipstick
3. Fusebox (engine compartment)
4. Brake reservoir
5. Clutch reservoir
6. Fuel cut-off switch
7. Cooling system reservoir

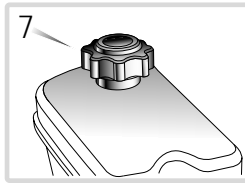
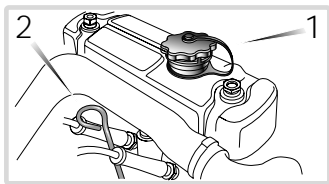

H2107

Engine

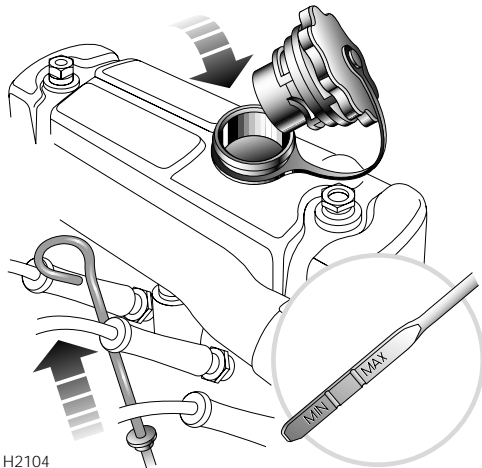

WARNING!

Driving with the oil level below the 'MIN' mark will damage the engine.

Oil specification:

10W/30 engine oil, meeting RES.22.OL.G4 or ACEA A2:96.

Suitable for use in temperatures between -20° C to +30° C (if climatic temperature falls outside these limits, seek advice from your dealer).

Most major oil companies produce engine oils to the above specification.

OIL LEVEL CHECK & TOP-UP

Check the oil level when the car is on level ground with the engine switched off. If the engine is warm, wait for at least two minutes before checking the level.

1. Pull out the dipstick and wipe the blade clean.
2. Re-insert the dipstick and withdraw again to check the level.
3. If the level is at or near the 'MIN' mark, twist to release the oil filler cap and add oil to bring the level close to the 'MAX' mark.
4. After adding oil, wait for at least two minutes, then recheck the level, adding more oil if necessary.
5. Finally, replace the dipstick and filler cap.

DO NOT fill above the 'MAX' mark!

Operating Tip

Check the oil when you fill up with fuel (refuel first, then check the oil - this allows time for the oil to drain into the sump before you check the level).

Cooling System

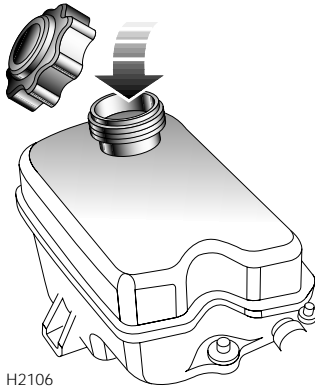

H2106

COOLANT CHECK & TOP-UP

Check the coolant level weekly when the engine is cold and, if necessary, top-up with a mixture of anti-freeze and water, so that the coolant is level with the horizontal seam half-way up the reservoir.

If the level falls appreciably during a short period, this may indicate a leak or engine overheating, in which case arrange for a Rover dealer to examine the car.

Anti-freeze

The anti-freeze content of the coolant should be maintained at 50%. This will protect the engine from frost in winter and corrosion throughout the year. To ensure that the anti-corrosion properties of the coolant are maintained, your dealer should check the anti-freeze every year.

Coolant specification:

A 50% mix of water and Unipart Superplus 3 Anti-freeze and Summer Coolant, or any ethylene glycol based anti-freeze meeting BS 6580 or BS 5117.

Care Points

Do not add rust inhibitors or other additives - they may not be compatible with the coolant or engine components.

WARNING!

DO NOT remove the filler cap when the system is hot - scalding steam or water may be released.

Anti-freeze is poisonous and can be fatal if swallowed. If accidental consumption of anti-freeze is suspected, seek medical attention immediately.

If anti-freeze contacts skin or eyes, rinse immediately with plenty of water.

Brakes & Clutch

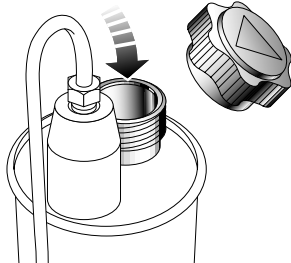

H2102

CLUTCH FLUID CHECK & TOP-UP

The fluid level may fall slightly during use. However, any appreciable drop in level within a short period may indicate a leak and should be reported to a Rover dealer immediately.

Topping-up

Add fluid until the level reaches the bottom of the filler neck.

Use only new fluid from sealed containers (old or used fluid, or fluid from an uncapped container, will absorb moisture and adversely affect performance).

Fluid specification:

- AP New Premium Super DOT 4 brake & clutch fluid.
- Castrol Universal DOT 4 brake & clutch fluid.

Care Points

Wipe the filler cap clean before removing to prevent dirt from entering the reservoir.

WARNING!

DO NOT allow fluid to contact the skin or eyes. If this occurs, rinse with plenty of water.

Fluid damages paintwork. Soak up any spillage immediately and wash affected area with car shampoo and water.

Brakes & Clutch

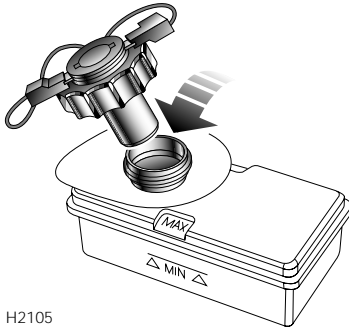

BRAKE FLUID CHECK & TOP-UP

The fluid level may fall slightly during use, but should not drop below the 'MIN' mark on the side of the reservoir. Any appreciable drop in level within a short period may indicate a leak and must be reported to a Rover dealer immediately.

Topping-up

1. Wipe the cap clean to prevent dirt from entering the reservoir.
2. Hold the terminal block steady to protect the electrical connections, and unscrew the cap.
3. Add fluid until the level reaches the 'MAX' mark.

Use only new fluid from sealed containers (old or used fluid, or fluid from an uncapped container, will absorb moisture and adversely affect braking performance).

Fluid specification:

- AP New Premium Super DOT 4 brake & clutch fluid.
- Castrol Universal DOT 4 brake & clutch fluid.

Care Points

Wipe the filler cap clean before removing to prevent dirt from entering the reservoir.

WARNING!

DO NOT drive if the fluid level is below the 'MIN' mark.

DO NOT allow fluid to contact the skin or eyes. If this occurs, rinse with plenty of water.

Fluid damages paintwork. Soak up any spillage immediately and wash affected area with car shampoo and water.

Washers

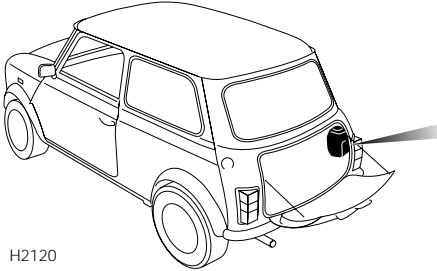

H2120

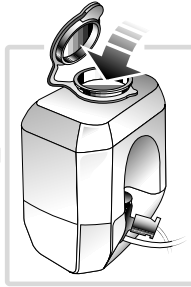

Reservoir capacity:
2.3 litre (4 pints)

WASHER RESERVOIR

The windscreen washer reservoir is in the luggage compartment. Check the level every week and top-up with a mixture of water and a good quality, proprietary screenwash. To ease refilling, the reservoir can be lifted clear of its mounting bracket to rest on the luggage compartment floor.

To prevent freezing in temperatures down to -7°C , use a mixture of 5 parts water to one of screenwash. A stronger solution of 2.5:1 will provide protection down to -12°C .

Care Points

Do not use anti-freeze or vinegar additives in the reservoir - anti-freeze will damage paintwork, while vinegar can damage the washer pump.

Washers

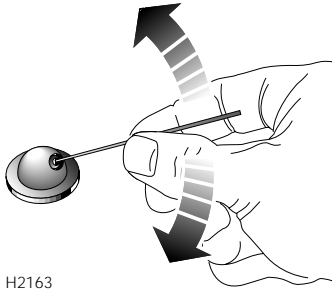

H2163

WASHER JETS

To adjust a jet, use a needle as a lever to reposition the jet hole. Direct the spray towards the upper half of the windscreen.

If a jet becomes blocked, use a thin wire as a probe to clear the obstruction.

Wipers

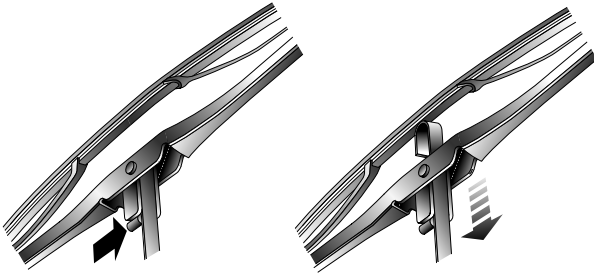

H2125

WIPER BLADE REPLACEMENT

1. Lift the wiper away from the windscreen
2. With the blade at right angles to the arm, press the locking tab (arrowed in LH illustration).
3. Keeping the locking tab pressed, slide the wiper blade down the arm until it is clear of the arm's hooked end. The blade can then be removed.

Fitting replacement blades is a reversal of this process. Only fit replacement blades that match the original specification.

Care Points

Grease, silicone and petrol based products impair the blade's wiping capability.

- Wash wipers in warm, soapy, water only!
- Protect blades by cleaning windscreen with glass cleaner after using wash and wax products.

If wipers leave streaks or unwiped areas on the screen, replace the blades.

Battery

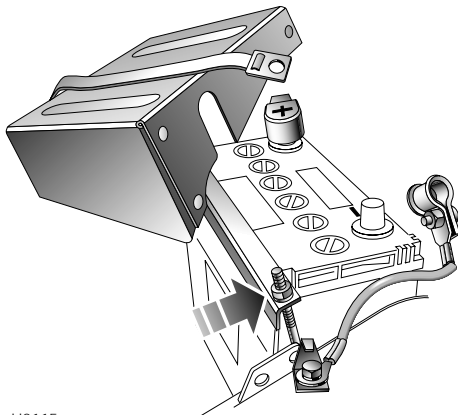

H2115

Battery removal & replacement

The battery is located in the luggage compartment. Before disconnecting the battery, remove the starter key and switch off all electrical equipment.

1. Release the securing strap and remove the battery cover.
2. Disconnect the battery leads. Always disconnect the negative (-) terminal before the positive (+) terminal. When reconnecting, connect the positive terminal first.
3. Slacken the nuts securing the battery clamp (arrowed in illustration). Swing the clamp away from the battery, and remove the battery.

Only fit a replacement battery of the same type, size and specification as the original. Other batteries may not fit the battery compartment in the luggage floor, or may have different terminal positions, which could create a fire hazard if the terminals or battery leads were to come into contact with the battery clamp.

Care Points

Used batteries are potentially dangerous; dispose at authorised waste sites only. After battery disconnection, the handset may need to be re-synchronised (see 'Handset battery').

After battery disconnection, the radio display may show 'CODE'. Enter the radio security code to restore operation (see 'In-car Entertainment' book).

WARNING!

For safety, remove metal wrist bands and jewellery. DO NOT allow tools or metal parts of the car to make contact with the battery terminals.

Battery

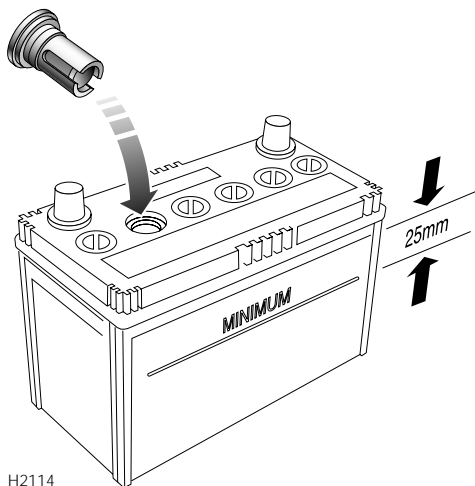

Care Points

On older batteries, prevent corrosion of the battery lead clamps by liberally smearing the battery terminals with petroleum jelly (e.g. Vaseline).

See 'Care Points' and WARNING! on previous page.

Battery maintenance

The battery is a low-maintenance type, and during normal use in temperate climates, will not require topping-up.

If it is necessary to top-up the electrolyte, proceed as follows:

1. Remove the battery from the car and stand it on a level surface.
2. Unscrew the vent caps and add distilled water to each cell, raising the level of the electrolyte until it is approximately 25 mm above the minimum level marked on the side of the battery.

Battery

Battery charging

Before charging, the battery must be removed from the car and the electrolyte topped-up above the minimum level (see previous pages).

Batteries generate explosive gases, contain corrosive acids and produce levels of electric current high enough to cause serious burns. Always observe the following precautions:

- Disconnect the battery charger from the power supply before attaching the charger leads to the battery.
- Make sure the leads are securely clamped to the battery terminals before switching on the charger. DO NOT move the clamps once the charger is switched on.
- Shield your eyes and avoid leaning over the battery.
- Ensure the area around the top of the battery is well ventilated.
- DO NOT permit naked lights near the battery (flammable hydrogen is emitted during and after charging).
- When charging has finished, switch off the charger BEFORE disconnecting the leads to the battery. Leave the battery for an hour before reconnection to the car.

WARNING!

Batteries contain acid. If acid contacts the eyes or skin, wash immediately with cold water and seek medical advice.

Batteries emit sufficient hydrogen to cause severe explosions if ignited. Keep naked lights and sparks away from the luggage compartment.

Tyres

Tyre care

Always drive with consideration for the condition of the tyres, and frequently inspect the tread and side walls for punctures and signs of damage. The most common causes of tyre failure are:

- Bumping against kerbs.
- Driving over kerbs and deep pot holes.
- Driving on unmetalled roads.
- Driving with over or under-inflated tyres.

Tyre pressures

Incorrectly inflated tyres will wear rapidly, or unevenly, and may also seriously affect the car's stability, road handling and fuel economy. Check the pressures every week (including the spare), **WHEN TYRES ARE COLD.**

The recommended pressures for **COLD TYRES** are shown in the 'Technical data' section at the back of this book. If the tyres are warm, **DO NOT** let air out in order to match them.

Tyre wear indicators

Wear indicators are moulded into the tread pattern at several points around the circumference of the tyre. As the tread wears, the indicators appear to rise towards the surface. When the depth of tread has reduced to approximately 1.6 mm, the indicators reach the surface, appearing as a continuous band of rubber, either around the circumference or across the width of the tyre. This warns that there is insufficient depth of tread to provide good traction.

In the interests of safety, a tyre should be renewed before the wear indicators reach the surface of the tread pattern.

WARNING!

DEFECTIVE OR INCORRECT TYRES ARE DANGEROUS!

Do not drive if any tyre is damaged, excessively worn, or inflated to an incorrect pressure.

Only fit tyres that are identical to the original specification or are approved by Rover.

Operating Tip

Be aware that air pressure increases in warm tyres, and after as little as a mile of driving, the tyres may already have warmed up and caused the pressures to have increased by as much as 6 lbf/in² (0.4 bar) - even in cold weather!

Tyres

Punctured tyres

Your car is fitted with tubeless tyres, which will not normally lose air immediately a sharp object penetrates the casing (provided the object remains in the tyre!). However, if you are aware that a tyre is punctured, drive at a reduced speed and with caution until the spare wheel can be fitted. Always have punctured tyres permanently repaired or replaced as soon as possible.

Replacing tyres

Wheel rims and tyres are matched to suit the handling characteristics of the car. Changing their specification may adversely affect your safety.

Only fit replacement wheels or tyres that conform to the specification shown in 'Technical Data' (at the back of this book), or have been approved by a Rover dealer.

Care Points

Keep the valve caps screwed down firmly to prevent dirt from entering the valve.

Frequently inspect the tread and side walls of the tyres for signs of distortion (bulges), cuts and wear, as well as punctures to the casing.

Cleaning & Car Care



H2122A

WASHING YOUR CAR

If the car is particularly dirty, use a hose to flush grime and grit from the surface prior to washing. Then wash the car using a clean, grit-free sponge and cold or lukewarm water containing a good quality wash and wax shampoo. Always use plenty of water to ensure that grit is flushed from the surface and not ground into the paintwork. After washing, rinse the car with clean water and dry off with a chamois leather.

During the winter if salt has been used on the roads, use a hose to wash the underside, paying particular attention to wheelarches and panel seams.

Removing tar spots

Use white spirit to remove tar spots and stubborn grease stains. Then wash immediately with soapy water to remove all traces of the spirit.

WARNING!

Some high pressure cleaning systems will penetrate door, window and sunroof seals, and damage lock mechanisms. DO NOT aim water jets directly at components that might easily be damaged.

Care Points

- DO NOT use hot water to wash the car.
- DO NOT use detergents or washing up liquid.
- In hot weather, DO NOT wash the car in direct sunlight.
- If using a hose, DO NOT direct the water directly at window, door or sunroof seals, or through wheel apertures onto brake components.
- If using an automatic car wash, remove the radio aerial before entering the car wash.

Cleaning & Car Care

Protecting paint damage

After washing, examine the paintwork for damage. Treat paint chips and scratches with a Rover paint touch-up pencil. If the damage has revealed bare metal, use a coloured primer first, then apply the base coat and finish off with a lacquer pencil, if appropriate. Carry out this treatment after washing but before polishing or waxing.

More extensive damage to paint or bodywork must be repaired in accordance with the manufacturer's recommendations - failure to do this may invalidate the Anti-Corrosion Warranty! Ask your Rover dealer for advice.

Polishing

Occasionally treat the paint surface with an approved polish containing the following properties: - very mild abrasives to remove surface contamination without removing or damaging the paint. - filling compounds that will fill scratches and reduce their visibility. - wax to provide a protective coating between the paint and the elements.

Always apply polish with a soft, clean cloth and follow the manufacturers application instructions implicitly.

Windows and mirrors

Regularly clean all windows inside and out using an approved glass cleaner.

Windscreen: In particular, clean the outside of the screen with glass cleaner after washing the car with wash and wax products, and before fitting new wiper blades.

Rear window: Clean the inside with a soft cloth, using a side to side motion to avoid damaging the heating elements. DO NOT scrape the glass or use abrasive cleaners - this will damage the heating elements.

Mirrors: Wash with soapy water. Use a plastic scraper to remove ice. DO NOT use abrasive cleaners or metal scrapers.

Chrome

Do not use any abrasive cleaners, the surface of the chrome will be impaired.

Care Points

- If possible, avoid applying polish or wax products to window glass or rubber seals.
- DO NOT scrape or use abrasive cleaners on the inside of the rear window - this will damage the heating elements.
- DO NOT use car polish containing coarse abrasives - these will remove the paint film and damage the gloss finish.

Cleaning & Car Care

Wiper blades

Wash in warm soapy water. DO NOT use spirit or petrol based cleaners.

Fabric sun roof

Wash with soapy water and a sponge, using a brush to remove stubborn dirt if necessary. If using a hose, avoid directing the water jet directly at the seal between sun roof and roof panel. NEVER use abrasive cleaners, or spirit, petroleum and chemical based cleaning agents.

Occasionally open the roof and clean dirt and debris from the roof frame. Also, treat the sealing rubber with an approved rubber preservative, and sparingly lubricate the sliding parts with an acid-free grease, such as Vaseline.

***NOTE:** In time, the application of too much grease may cause the roof to stick and damage the roof mechanism.*

Cleaning & Car Care

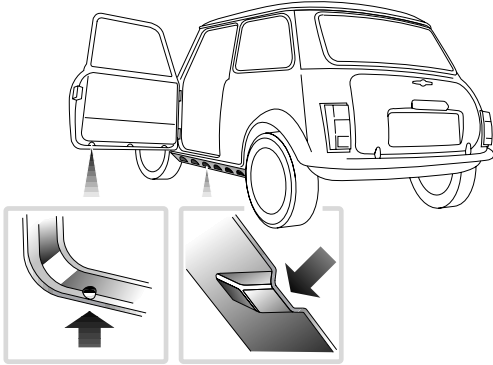

H2126A

Body drainage points

In muddy conditions, the door and body drainage points (shown in illustration) could become blocked. From time to time use a probe (preferably made from wood or plastic - not metal) to clear any build up of debris that might obstruct drainage.

Cleaning & Car Care

CLEANING THE INTERIOR

Plastic materials: Clean with diluted upholstery cleaner or warm water and a non-detergent soap (to achieve a matt, sheen-free, finish).

Fabrics: Clean with upholstery cleaner.

Leather: Seats and any other trim features should be cleaned with warm water and a non-detergent soap. Dry and polish the leather with a clean, dry, lint-free cloth.

Carpet: Clean with diluted upholstery cleaner.

Steering wheel centre pad (airbag module)

To prevent damage to the airbag SRS, the steering wheel centre pad should **ONLY** be cleaned sparingly with a damp cloth and upholstery cleaner. **DO NOT** flood the area, or use petrol, detergent, furniture cream or other polishes.

Seat belts

Extend the belts, then use warm water and a non-detergent soap to clean. Allow the belts to dry naturally; **DO NOT** retract them or use the car until they are completely dry.

Fascia

Clean with a damp cloth. Use a mild detergent to remove any marks. A light application of furniture polish will protect the surface.

Care Points

- **DO NOT** polish plastic fascia components - these should remain non-reflective.
- **DO NOT** use bleaches, dyes or cleaning solvents on seat belts.

Emergency Towing

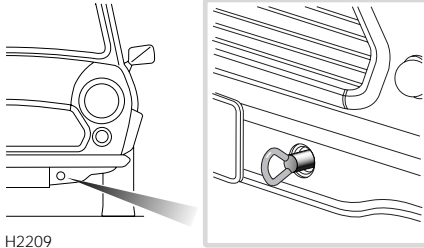

H2209

For Your Safety

While towing do not exceed 30 mph (45 km/h) and always remember; without the engine running, greater effort will be required to operate the brake pedal and longer stopping distances will be experienced.

If, due to an accident or electrical fault, it is considered unsafe to turn the starter switch to position 'I', disconnect the battery before turning the switch.

Towing for recovery

If your car is to be towed, most qualified recovery specialists will use wheel lift equipment to suspend the front wheels. However, if it is necessary for the car to be towed with all four wheels on the ground, use the front towing eye, located beneath the front bumper and follow this procedure.

Before towing:

1. Turn the starter key to position 'I' to unlock the steering and then to position 'II' to enable the brake lights, wipers and direction indicators to be operated if necessary.
2. Place the gear lever in neutral.
3. Release the handbrake.

WARNING!

DO NOT remove the starter key or turn the starter switch to position '0' while the car is in motion.

Care Points

If a fault with the gearbox is suspected, or the engine/gearbox oil is low, the car should only be moved on suspended tow (with the front wheels raised from the ground).

Emergency Towing

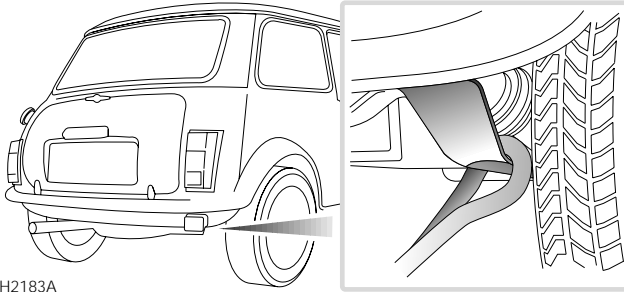

H2183A

For Your Safety

- DO NOT use the lashing points for towing another vehicle, trailer or caravan.

Transporter or trailer lashing

If your car should require transporting on the back of a trailer or transporter, only use the front towing eye and the recommended lashing points on either side of the rear subframe, illustrated above - DO NOT secure lashing hooks or trailer fixings to other parts of the car.

When lashing the rear subframe, ensure that any ropes, hooks or fixings pass UNDER the suspension strut.

Wheel Changing

CHANGING A WHEEL

Before changing a wheel, apply the handbrake and select 1st gear. If jacking on a slope, place chocks at the front and rear of the wheel diagonally opposite the one to be removed.

The steel spare wheel and tool kit are stowed in the luggage compartment.

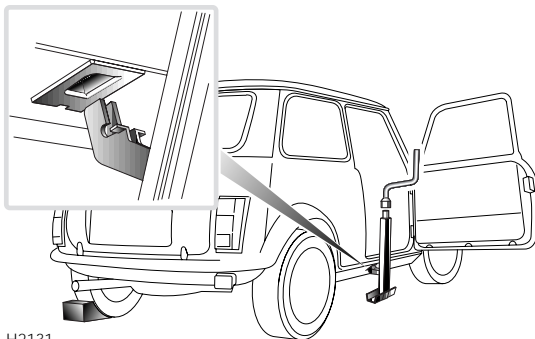

H2131

Positioning the jack

Position the car so that the jack will bear on firm level ground; NEVER on soft ground, or over metal gratings and manhole covers.

With the door open, insert the jack head into the jacking point in the sill (see illustration). Turn the jack screw clockwise until the base of the jack sits firmly on the ground; check that the jack is vertical with its head fully inserted into the jacking point.

For Your Safety

- If possible, change the wheel away from the main thoroughfare.
- Ensure passengers get out of the car and wait in a safe area away from other traffic.
- Use your hazard warning lights to alert other road users.

WARNING!

NEVER jack the car with passengers inside.
NEVER work beneath the car with the jack as the only means of support. The jack is designed for wheel changing only.

Wheel Changing

Changing the wheel

IMPORTANT: If the wider 175/50 tyres are fitted to the car, refer to the important information below before changing the wheel.

Before raising the car, slacken the wheel nuts half a turn. Then, using the wheel nut spanner to turn the jack screw, raise the car until the tyre is clear of the ground.

Remove the wheel nuts and wheel (see '*Locking wheel nuts*').

Fit the steel spare wheel and refit the wheel nuts (tapered side towards the wheel), tightening them until the wheel is firmly seated against the hub. Do not apply full tightening forces while the tyre is clear of the ground. Lower the car and remove the jack and wheel chocks, then **FULLY** tighten the wheel nuts in diagonal sequence to the correct torque (see '*Wheels & tyres*' in '*Technical Data*').

For Your Safety

After changing a wheel, have the tyre pressure and wheel nut torque checked as soon as possible.

Care Points

Avoid placing wheels face down on the ground. This may scratch the alloy surface.

IMPORTANT INFORMATION

For cars fitted with 175/50 tyres only.

The steel spare wheel supplied with these cars is of a different size and specification to the (much larger) alloy road wheels, and is for temporary use only. It must be replaced by the normal size wheel as soon as possible.

Use of this wheel is subject to the following:

1. If the spare wheel is to be used as a rear wheel: **ENSURE** the wheel spacer is left in place on the rear hub when the spare wheel is fitted.
2. If the spare wheel is to be used as a front wheel: **DO NOT**
3. **RESTRICT** road speed to a maximum of 50 mph (80 km/h).
4. **ENSURE** the spare tyre is inflated to 28 lbf/in² (2.0 bar). accelerate rapidly with the spare wheel fitted.
5. Only one spare wheel is to be used on the car at any one time.

Wheel Changing

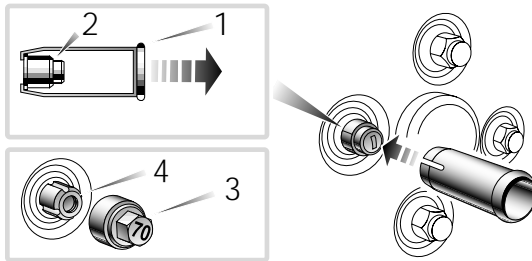

H2124A

IMPORTANT

A code number is stamped on the face of the socket. Ensure the number is recorded on the Security Information Card supplied with the literature pack. Quote this number if replacements are required. For security reasons, DO NOT keep the card in the car.

LOCKING WHEEL NUTS

One locking wheel nut is fitted to each road wheel. Locking wheel nuts are visually similar to standard wheel nuts, but can only be removed using the special tools provided, as follows:

Push the extractor (1) firmly over the head of the locking wheel nut. Pull to remove the nut cover (2).

Fit the key socket (3) over the locking wheel nut (4) then, using the wheel nut spanner, unscrew the nut in the normal way.

NOTE: *The key socket can be retained inside the extractor tube when not in use.*

Fuses

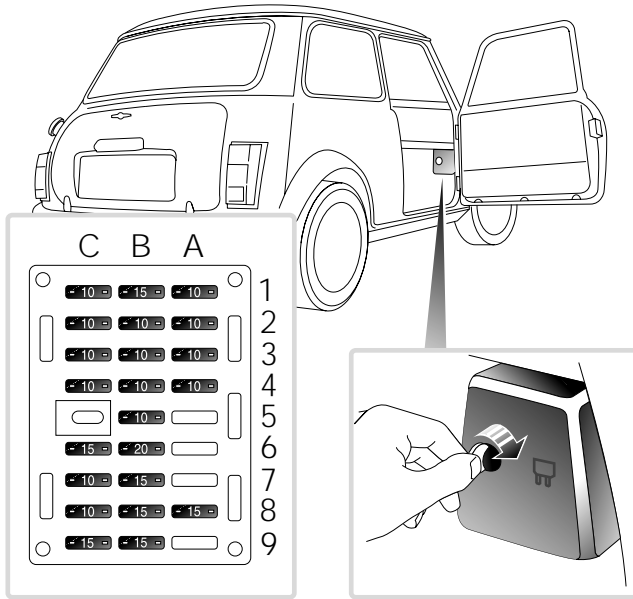

H2165A

In brief

Fuses are simple circuit breakers, which protect the car's electrical equipment by preventing the electrical circuits from being overloaded.

A blown fuse may be indicated when the item of electrical equipment it protects stops working.

For Your Safety

Turn off the starter switch and all electrical equipment before changing a fuse.

Only replace a fuse with one of the same, or lower, rating.

MAIN FUSE BOX - Checking or renewing a fuse

1. Turn off the starter switch and all electrical equipment.
2. Remove the fuse box cover (use a coin to turn the retaining screw a quarter turn to left or right), then refer to the chart to identify the suspect fuse.
3. Hold the head of the fuse and pull to remove. A blown fuse can be recognised by a break in the wire (see illustration on the following page).
4. Replace a blown fuse with another of the same, or lower, rating. Note that there are a number of spare fuses around the perimeter of the fuse box.

If a replacement fuse fails almost immediately, refer the problem to your dealer.

Fuse colours:

RED 10 amp

BLUE 15 amp

YELLOW 20 amp

Fuses

MAIN FUSE BOX (inside the car)

Fuse No	Rating (amps)	Circuits protected
A1	10	Headlight main beam - RH
A2	10	Headlight dipped beam - RH
A3	10	Side and tail lights - RH
A4	10	Alarm system, instruments, engine management
A5	-	-
A6	-	-
A7	-	-
A8	15	Heater blower
A9	-	-
B1	15	Driving lights
B2	10	Rear fog guard light
B3	10	Headlight levelling
B4	10	Ignition auxiliaries, radio
B5	10	Airbag SRS
B6	20	Alarm system and horn
B7	15	Sunroof
B8	15	Wipers
B9	15	Engine cooling fan
C1	10	Headlight main beam - LH
C2	10	Headlight dipped beam - LH
C3	10	Side and tail lights - LH
C4	10	Radio, brake test switch, alarm, direction indicators, clock
C6	15	Direction indicators, stop lights, reversing lights
C7	10	Fuel pump
C8	10	Engine cranking
C9	15	Heated rear screen

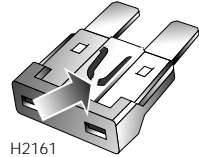

H2161

A blown fuse can be recognised by a break in the wire.

Fuses

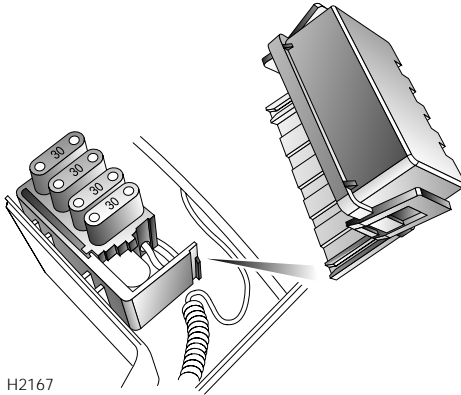

H2167

ENGINE COMPARTMENT FUSES

Four fusible links are situated in a small fuse box at the front right hand side of the engine compartment. These protect the wiring between the battery and the main fuse box, and should be checked if an electrical failure appears to have affected a number of different systems, or one which has not caused a fuse to fail in the main fuse box.

Fuses

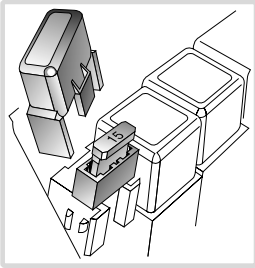

H2168

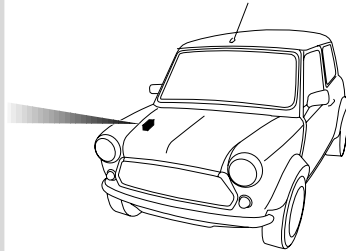

A single 15 amp fuse, located on the right side of the engine compartment protects the front fog lights (if fitted).

Bulb Replacement

For Your Safety
Check the operation of all exterior lights before you use the car.

Care Points
Before replacing a bulb, turn off the lighting switch to avoid any possibility of a short circuit.
Only replace bulbs with the same type and specification.

During use, headlight bulbs may shatter if the glass has been scratched, or contaminated with oil or perspiration. **DO NOT** touch the glass. If handled, clean with methylated spirits and a clean cloth.

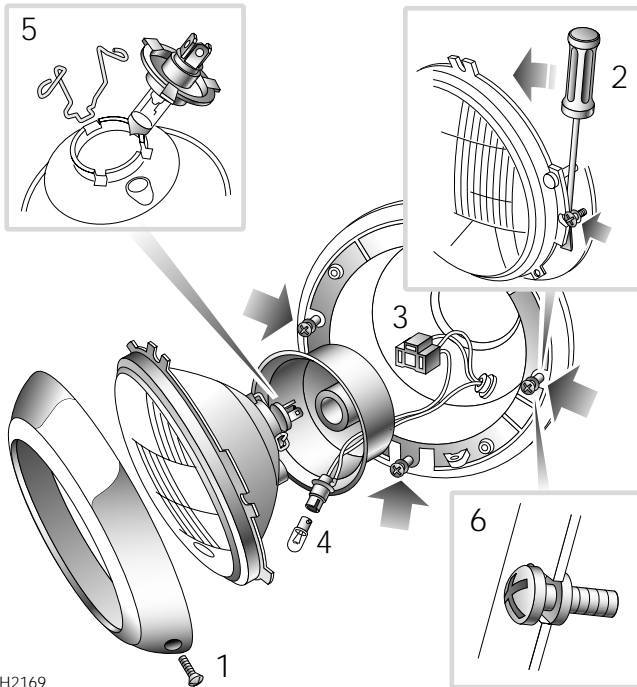

H2169

Headlight (and sidelight)

1. Remove the screw and headlight finisher.
2. Using a screwdriver as a lever (see illustration), lever the headlight to the left (looking towards the front of the car) and spring it free of the retaining screw (arrowed in illustration). The headlight can then be lifted clear of the other two retaining screws. Note that all three retaining

Bulb Replacement

screws also control headlight alignment and, for this reason, must not be removed: they are mounted in a pliable material with sufficient flexibility to enable the headlight to be sprung free without disturbing the alignment.

3. Detach the plug from the back of the headlight, and pull back the rubber boot.
4. Sidelight: Pull the bulb holder from the back of the headlight. Push and twist the bulb to remove.
5. Headlight: Unhook both ends of the retaining clip, then remove the bulb. When replacing, ensure that the larger of the three rectangular tabs on the bulb's base plate fits the uppermost slot on the rear of the light unit.
6. When replacing the headlight unit, ensure the slots in the headlight rim engage between the shoulder and head of the retaining screws (see inset).

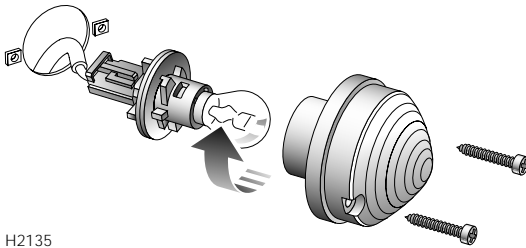

H2135

Front direction indicator

1. Remove two screws securing the lens to the body.
2. Hold the lens firmly and twist the bulb holder a quarter turn anti-clockwise to release it from the lens.
3. Push and twist the bulb anti-clockwise to remove it from the bulb holder.

Bulb Replacement

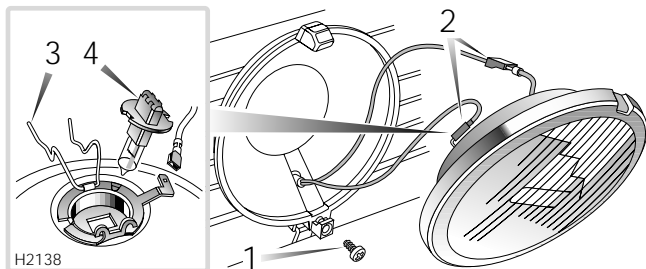

Care Points

During use, these bulbs may shatter if the glass has been scratched, or contaminated with oil or perspiration. **DO NOT** touch the glass. If handled, clean with methylated spirits and a clean cloth.

Fog and driving lights (if fitted)

1. Remove the screw at the base of the light. This will release the lens and bulb assembly from the lamp body.
2. Detach both electrical connectors.
3. Unhook both sides of the retaining clip, and pivot the clip away from the rear of the light.
4. The bulb can now be removed. When replacing a bulb, note that shaped cut-outs in the metal base plate ensure the bulb's correct alignment.

Bulb Replacement

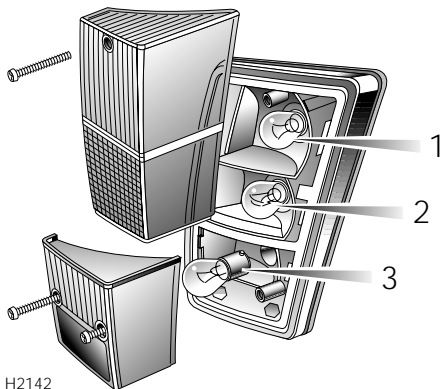

Rear light unit

Remove three screws to release the lens. The lens is made in two parts, which slot together. When replacing the lens, the upper part must be placed in position first; the lower part then 'captures' the upper as the screws are tightened.

Push and twist anti-clockwise to remove a bulb.

1. Direction indicator.
2. Brake/tail light (Note the 'stepped' bayonet fitting; this ensures that the twin filament bulb is replaced correctly).
3. Reversing light.

Bulb Replacement

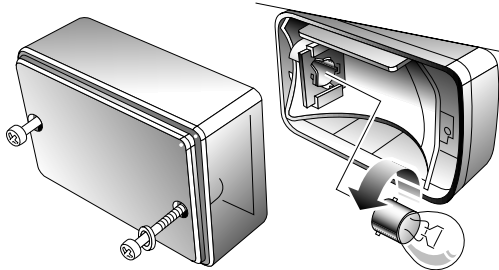

H2140

Rear fog guard light

Remove two screws securing the lens to the body. Remove the lens, then push and twist the bulb anti-clockwise to remove it from the holder.

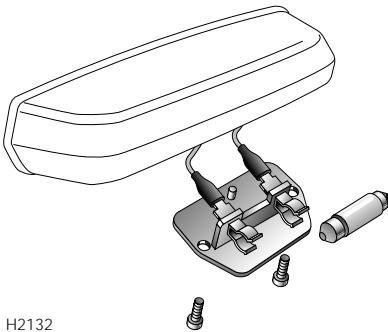

H2132

Number plate light

Remove two screws securing the lens to the light housing. Ease the light unit from its recess and pull the bulb to remove.

Bulb Replacement

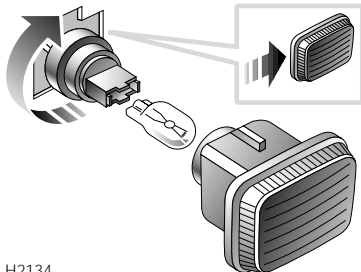

H2134

Side repeater light

1. Push the light unit firmly to the right to withdraw it from the front wing.
2. Twist the bulb holder anti-clockwise to release it from the lens.
3. Pull to remove the bulb from its socket.

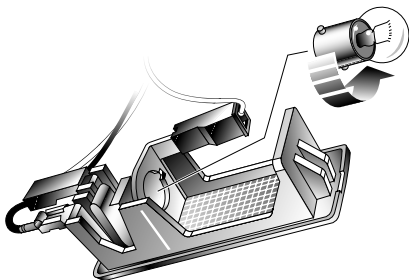

H2113

Interior light

From the end opposite the switch, use a small, flat-bladed, screw driver to prise the light unit from the roof lining.

Push and twist the bulb anti-clockwise to remove it from the bulb holder.

Bulb Replacement

REPLACEMENT BULBS

Headlight (halogen):	60/55 watts	GLB 472
Auxiliary (halogen):	55 watts	GLB 453
Sidelight:	4 watts	GLB 233
Direction indicator:	21 watts	GLB 382
Side repeater:	5 watts	GLB 501
Reversing light:	21 watts	GLB 382
Stop/tail light:	21/5 watts	GLB 380
Fog guard light:	21 watts	GLB 382
Number plate light:	5 watts	GLB 239
Interior light:	10 watts	GLB 245

Parts & Accessories

SERVICE PARTS & ACCESSORIES

Only Rover dealers are able to provide the full range of recommended parts and accessories that meet our rigorous standards of safety, durability and performance.

It makes sense, therefore, to always consult a Rover dealer regarding the suitability, installation and use of any parts and accessories.

Travelling abroad

In some countries it may be illegal to fit parts that have not been made to the vehicle manufacturer's specification. Owners should ensure that any parts or accessories fitted to the car while travelling abroad will also conform to the legal requirements of their home country.

WARNING!

Fitting parts or accessories that have not been approved by Rover may be dangerous and could invalidate the vehicle warranty.

If an airbag SRS is fitted, ALWAYS consult a Rover dealer before fitting any spare part or accessory.

It may be dangerous to fit parts or accessories where installation requires the dismantling of, or addition to, either the electrical or fuel systems.

Vehicle Identification

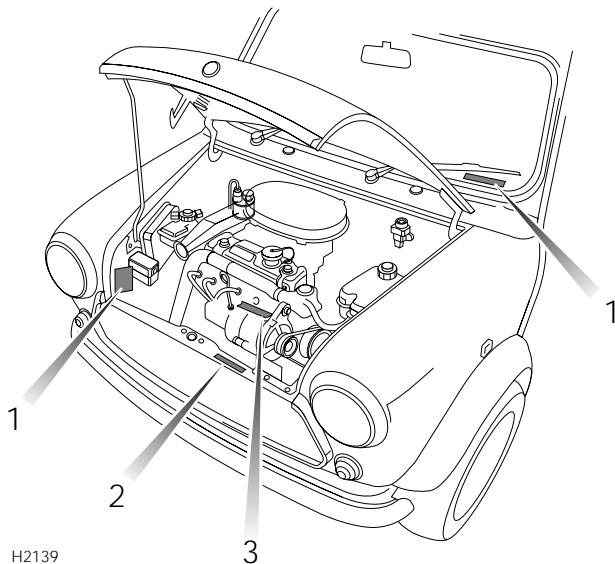

H2139

Care Points

If buying the car second-hand, check that the vehicle identification number on the VIN plate matches that shown in the Service Portfolio book and on the vehicle registration documents.

A stencil for the VIN may be supplied with the car. Use this stencil to re-etch the VIN if ever a replacement windscreen is fitted.

IDENTIFICATION NUMBERS

1. Vehicle identification number (VIN)

Stamped on a metal plate attached to the right hand wing valance. Also, as a deterrent to car thieves and to help the police, the VIN is etched into the windscreen and rear window.

The exterior body colour and interior trim codes are also stamped on the VIN plate and should be quoted if paint or trim items are required.

2. Body number

Stamped on a plate attached to the bonnet locking platform.

3. Engine number

Stamped into a horizontal surface of the cylinder block below the spark plugs.

Technical Data

Engine

Capacity	1275 cm ³
Firing order.....	1-3-4-2
Idle speed.....	875 rev/min
Fuel.....	95 RON UNLEADED to EN 228 specification

Ignition system

Type	Programmed ignition system
Spark plugs	NGK BPR6E
Spark plug gap	0.85 ± 0.05 mm

Electrical

Battery type	Low maintenance
Voltage/polarity	12V, negative (-) earth

Wheels & tyres

Wheel size & type:	
Alloy wheel (standard)	4.5 x 12
Alloy wheel (option)	6 x 13
Steel spare wheel	4.5 x 12
Road wheel nut torque	60 Nm
Tyre size:	
Standard	145/70 SR12
Option	175/50 VR13 Dunlop SP Sport 2000 or 3000
Spare (steel wheel).....	145/70 SR12
Tyre pressures:	
145/70 SR12 (Standard)	28 lbf/in ² 2.0 bar
175/50 VR13 (Option)	
Front	28 lbf/in ² 2.0 bar
Rear	26 lbf/in ² 1.8 bar
Spare (145/70 SR12 steel wheel).....	28 lbf/in ² 2.0 bar

Technical Data

Weights

Approx unladen weight (full fuel tank, excluding options)	715 kg	1576 lb
Maximum gross vehicle weight	1050 kg	2315 lb
Maximum rear axle weight	510 kg	1124 lb
Maximum roof rack load*	50 kg	110 lb

* The maximum roof rack load is conditional on the vehicle loading being restricted to three occupants and no boot luggage (see 'Load carrying').

Dimensions

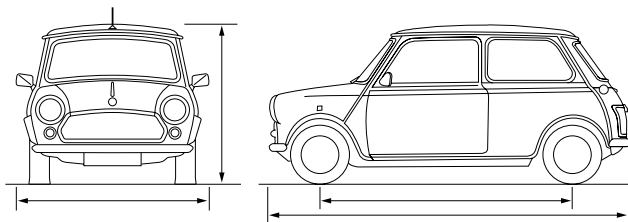

H2128

Overall length	3.05 m	10 ft 0.25 in
Overall width (including door mirrors)	1.58 m	5 ft 2.2 in
Overall height (at unladen weight)	1.34 m	4 ft 5 in
Wheelbase	2.04 m	6 ft 8 in
Turning circle (kerb to kerb):		
145/70 tyres	8.6 m	28ft 2.5 in
175/50 tyres	8.8 m	28ft 10.5 in

Capacities

Engine oil (refill)	4.8 litre	8.4 pt
Fuel tank	34 litre	7.5 gal
Cooling system	4.0 litre	7 pt
Washer reservoir	2.3 litre	4.0 pt

Technical Data

FUEL CONSUMPTION

The fuel consumption figures shown below have been calculated using a standard testing procedure (the new EC test procedure from Directive 93/116/EC), and produced in accordance with The Passenger Car Fuel Consumption (Amendment) Order 1996. Under normal use, a car's actual fuel consumption figures may differ from those achieved through the test procedure, depending on driving technique, road and traffic conditions, environmental factors, vehicle load and condition.

Fuel consumption figures

URBAN		EXTRA-URBAN		COMBINED	
mpg	l/100km	mpg	l/100km	mpg	l/100km
33.4	8.5	51.8	5.5	43.0	6.6

Urban cycle

The urban test cycle is carried out from a cold start and consists of a series of accelerations, decelerations and periods of steady speed driving and engine idling. The maximum speed attained during the test is 31 mph (50 km/h) with an average speed of 12 mph (19 km/h).

Extra-urban cycle

The extra urban test cycle is carried out immediately after the urban test. Approximately half of the test comprises steady-speed driving, while the remainder consists of a series of accelerations, decelerations and engine idling. The maximum test speed is 75 mph (120 km/h) and the average speed 39 mph (63 km/h). The test is carried out over a distance of 4.3 miles (7 km).

Combined

The combined figure is an average of the urban and extra-urban test cycle results, which has been weighted to take account of the different distances covered during the two tests.

NOTE: *These figures should not be compared with figures produced using the ECE/EEC procedure previously required by The Passenger Car Fuel Consumption Order 1983. Because of the changes in test procedure, even the urban figures would differ if the same car were subjected to both tests.*

Index

A					
Accessories	85	Distance recorder	30	Headlights	33, 43
Aerial	28	Door locks	5	Heating	23
Airbag SRS	15, 32	Driving lamps	43	I	
Alarm system	4	E		Identification numbers	86
Anti-freeze	53	Empty fuel tank	40	Ignition system	87
Anti-theft alarm	4	Engine	52	In-car entertainment	28
Anti-theft alarm indicator	32	Engine compartment	51	Indicators	43
Ashtray	27	Engine immobilisation	4	Instruments	30
B		Engine number	86	Interior light	25
Battery	59	Engine oil	52	Interior mirror	18
Battery charging	32	Engine	87	J	
Body number	86	F		Jacking	71
Bonnet opening	50	Face level vents	23	K	
Brake fluid level	55	Fog guard lights (rear)	45	Keys	5
Brake pads	46	Fog lights	45	L	
Braking system	46, 54	Fuel consumption	89	Lights	43
Bulb replacement	78	Fuel cut-off switch	41	Load carrying	29
C		Fuel economy	36	Locking wheel nuts	73
Capacities	88	Fuel filler	40	Locks	4
Car care	64	Fuel gauge	30	Luggage compartment lock	6
Catalytic converter	37	Fuel system	40	M	
Child seats	13	Fuses	74	Maintenance	48
Cleaning	64	G		Mirrors	18
Clock	26	Gearbox	39	N	
Clutch fluid level	54	General data	86	Number plate light	82
Controls	3	Glovebox	27	O	
Cooling system	53	H		Oil level (engine)	52
D		Handbrake	47	Owner maintenance	48
Data	86	Handset	8		
Demister (rear screen)	45	Handset battery	9		
Dimensions	88	Hazard warning lights	45		
Dipstick - engine oil	52	Head restraints	10		
Direction indicators	33, 43	Headlight levelling	44		

Index

P		T	
Parking	35	Tachometer	30
Parts	85	Technical data	86
Poisonous fluids	49	Temperature gauge	30
Polishing	65	Towing	69
Pre-tensioners	14	Towing for recovery	69
Punctured tyres	63	Tyre pressures	62, 87
		Tyres	62, 87
R		V	
Radio	28	Vanity mirror	19
Radio aerial	28	Vehicle identification number (VIN)	86
Radio/cassette player	28	Ventilation	23
Rear fog guard light	45		
Rear screen demister	45	W	
Rear window shelf	29	Warning lights	32
Roof rack	29	Washer jets	57
Running-in	36	Washing your car	64
		Weights	88
S		Wheel changing	71
Safety in the garage	49	Wheels	87
Seat belt safety	12	Windows	20
Seat belts	12	Windscreen washers	42, 56
Seats	10	Wiper blade replacement	58
Security information card	8	Wipers	42, 58
Service Portfolio book	48		
Side repeater light	83		
Sidelights	43		
Snow chains	63		
Spare wheel	71		
Speedometer	30		
Starter switch	34		
Starting	34		
Steering lock	34		
Sun visor	19		
Sunroof	21		
Switches	45		
Switching off	35		

Emergency Procedures

Bulb replacement	78
Fuel cut-off switch	41
Fuses	74
Hazard warning lights	45
Sunroof emergency operation	22
Towing for recovery	69
Wheel changing	71
